



# Bobcat®

## Service Manual

---



---

# E50

## Compact Excavator

S/N AJ1811001 & Above



CLICK HERE TO **DOWNLOAD** THE COMPLETE MANUAL

- Thank you very much for reading the preview of the manual.
- You can download the complete manual from: [www.heydownloads.com](http://www.heydownloads.com) by clicking the link below



- Please note: If there is no response to CLICKING the link, please download this PDF first and then click on it.

CLICK HERE TO **DOWNLOAD** THE COMPLETE MANUAL

## SAFETY INSTRUCTIONS



### Safety Alert Symbol

This symbol with a warning statement means:  
“Warning, be alert! Your safety is involved!”  
Carefully read the message that follows.



## WARNING

### AVOID INJURY OR DEATH

Instructions are necessary before operating or servicing machine. Read and understand the Operation & Maintenance Manual, Operator's Handbook and signs (decals) on machine. Follow warnings and instructions in the manuals when making repairs, adjustments or servicing. Check for correct function after adjustments, repairs or service. Untrained operators and failure to follow instructions can cause injury or death.

W-2003-0807

## IMPORTANT

This notice identifies procedures which must be followed to avoid damage to the machine.

I-2019-0284



## DANGER

The signal word DANGER on the machine and in the manuals indicates a hazardous situation which, if not avoided, will result in death or serious injury.

D-1002-1107



## WARNING

The signal word WARNING on the machine and in the manuals indicates a potentially hazardous situation which, if not avoided, could result in death or serious injury.

W-2044-1107

The following publications provide information on the safe use and maintenance of the Bobcat machine and attachments:

- The Delivery Report is used to assure that complete instructions have been given to the new owner and that the machine is in safe operating condition.
- The Operation & Maintenance Manual delivered with the machine or attachment contains operating information as well as routine maintenance and service procedures. It is a part of the machine and can be stored in a container provided on the machine. Replacement Operation & Maintenance Manuals can be ordered from your Bobcat dealer.
- Machine signs (decals) instruct on the safe operation and care of your Bobcat machine or attachment. The signs and their locations are shown in the Operation & Maintenance Manual. Replacement signs are available from your Bobcat dealer.
- An Operator's Handbook fastened to the operator cab. It's brief instructions are convenient to the operator. The handbook is available from your dealer in an English edition or one of many other languages. See your Bobcat dealer for more information on translated versions.
- The AEM Safety Manual delivered with the machine gives general safety information.
- The Service Manual and Parts Manual are available from your dealer for use by mechanics to do shop-type service and repair work.
- The Compact Excavator Operator Training Course is available through your local dealer or at **Bobcat.com/training** or **Bobcat.com**. This course is intended to provide rules and practices of correct operation of the Bobcat excavator. The course is available in English and Spanish versions.
- Service Safety Training Courses are available from your Bobcat dealer or at **Bobcat.com/training** or **Bobcat.com**. They provide information for safe and correct service procedures.
- The Bobcat compact excavator Safety Video is available from your Bobcat dealer or at **Bobcat.com/training** or **Bobcat.com**.

REMOTE START TOOL (SERVICE TOOL) KIT - 7217666 .....	10-211-1
Description .....	10-211-1
Remote Start Tool (Service Tool) - 7022042 .....	10-211-2
Excavator Service Tool Harness - 6689747 .....	10-211-3
Computer Service Tool Harness - 6689746 .....	10-211-4

## OPERATOR CAB (ROPS / TOPS) (CONT'D)

### Right Side Windows

#### *Opening The Right Rear Window*

**Figure 10-30-10**

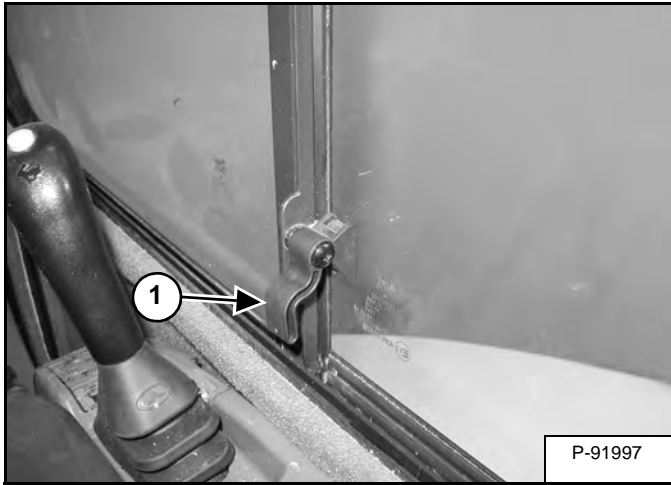

Raise the latch (Item 1) [Figure 10-30-10] located at the rear of the front window.

**Figure 10-30-11**

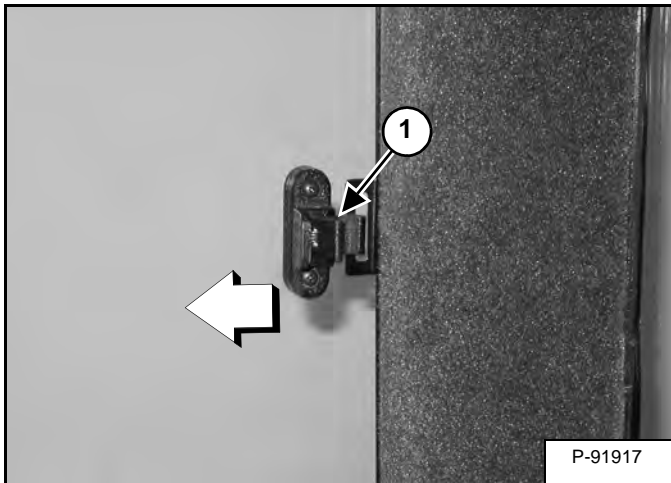

Pull out on the latch (Item 1) [Figure 10-30-11].

**Figure 10-30-12**

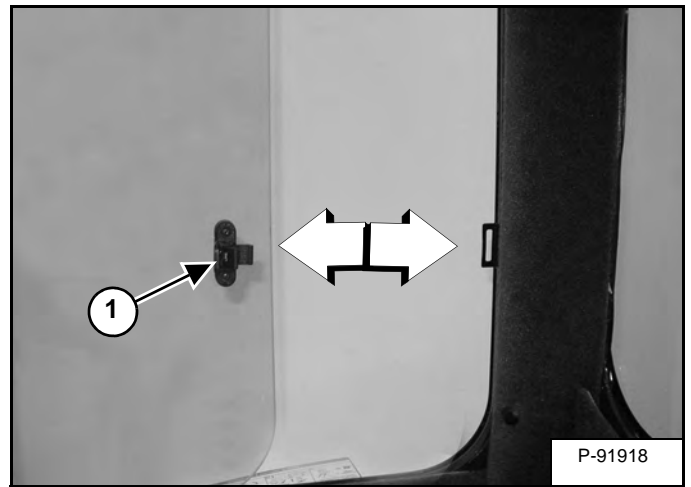

Pull the latch (Item 1) [Figure 10-30-12] forward to open the window. When the window is in the open position, push down on the latch (Item 1) [Figure 10-30-10].

#### *Closing The Right Rear Window*

Raise the latch (Item 1) [Figure 10-30-10].

Push the latch (Item 1) [Figure 10-30-12] back to close the window. Rotate the latch (Item 1) [Figure 10-30-10] down.

## SERVICE SCHEDULE

### Maintenance Intervals

Maintenance work must be done at regular intervals. Failure to do so will result in excessive wear and early failures.

The service schedule is a guide for correct maintenance of the Bobcat excavator.



#### AVOID INJURY OR DEATH

Instructions are necessary before operating or servicing machine. Read and understand the Operation & Maintenance Manual, Operator's Handbook and signs (decals) on machine. Follow warnings and instructions in the manuals when making repairs, adjustments or servicing. Check for correct function after adjustments, repairs or service. Untrained operators and failure to follow instructions can cause injury or death.

W-2003-0807

#### *Every 10 Hours (Before Starting The Excavator)*

- **Engine Oil** - Check level and add as needed.
- **Engine Air Filters and Air System** - Check display panel. Service only when required. Check for leaks and damaged components.
- **Engine Cooling System** - Check coolant level COLD and add premixed coolant as needed.
- **Hydraulic Fluid** - Check fluid level and add as needed.
- **Fuel Filter** - Drain water and sediment from filter.
- **Seat Belt, Seat Belt Retractors, Seat Belt Mounting hardware, Control Console Lockout** - Check the condition of seat belt and mounting hardware. Clean or replace seat belt retractors as needed. Check the control console lockout lever for proper operation. Clean dirt and debris from moving parts.
- **Motion Alarm** - Check for proper function.
- **Operator Canopy / Cab** - Check the canopy / cab condition and mounting hardware.
- **Operator Cab and HVAC Filters** - Clean filters as needed.
- **Indicators and Lights** - Check for correct operation of all indicators and lights.
- **Safety Signs** - Check for damaged signs (decals). Replace any signs that are damaged.
- **Track Tension** - Check tension and adjust as needed.
- **Pivot Points** - Grease all machinery pivot points. Grease clamp and angle blade (if equipped).
- **X-Change / Attachment Coupler** - Check for damage or loose parts (if equipped).

#### *First 50 Hours*

- **Engine Oil and Filter** - Replace oil and filter.
- **Hydraulic Filter, Case Drain Filter and Hydraulic Reservoir Breather Cap** - Replace the hydraulic filter, case drain filter and the reservoir breather cap.
- **Alternator and Starter** - Check connections.
- **Drive Belts (Alternator) (Air Conditioning - If Equipped)** - Check condition. Replace as needed.

#### *Every 50 Hours*

- **Swing Bearing** - Grease swing bearing and swing pinion. Service every 10 hours when operating in water.
- **Battery** - Check cables, connections, and electrolyte level; add distilled water as needed.
- **Fuel Tank** - Drain water and sediment from fuel tank and fuel filter.

SS EXC E32 - E55 T4-B-0118

## FUEL SYSTEM

### Fuel Specifications

**NOTE: Contact your local fuel supplier to receive recommendations for your region.**

*U.S. Standard (ASTM D975)*

Use only clean, high quality diesel fuel, Grade Number 2-D or Grade Number 1-D.

Ultra low sulfur diesel fuel must be used in this machine. Ultra low sulfur is defined as 15 mg/kg (15 ppm) sulfur maximum.

The following is one suggested blending guideline that should prevent fuel gelling during cold temperatures:

TEMPERATURE	GRADE 2-D	GRADE 1-D
Above -9°C (+15°F)	100%	0%
Down to -21°C (-5°F)	50%	50%
Below -21°C (-5°F)	0%	100%

**NOTE: Biodiesel blend fuel may also be used in this machine. Biodiesel blend fuel must contain no more than five percent biodiesel mixed with ultra low sulfur petroleum based diesel. This biodiesel blend fuel is commonly marketed as B5 blended diesel fuel. B5 blended diesel fuel must meet ASTM specifications.**

*E.U. Standard (EN590)*

Use only clean, high quality diesel fuel that meets the EN590 specifications listed below:

- Ultra low sulfur diesel fuel defined as 10 mg/kg (10 ppm) sulfur maximum
- Diesel fuel with cetane number of 51.0 and above.

**NOTE: Biodiesel blend fuel may also be used in this machine. Biodiesel blend fuel must contain no more than seven percent biodiesel mixed with ultra low sulfur petroleum based diesel. This biodiesel blend fuel is commonly marketed as B7 blended diesel fuel. B7 blended diesel fuel must meet EN590 specifications.**

## Biodiesel Blend Fuel

Biodiesel blend fuel has unique qualities that should be considered before using in this machine:

- Cold weather conditions can lead to plugged fuel system components and hard starting.
- Biodiesel blend fuel is an excellent medium for microbial growth and contamination that can cause corrosion and plugging of fuel system components.
- Use of biodiesel blend fuel may result in premature failure of fuel system components, such as: plugged fuel filters and deteriorated fuel lines.
- Shorter maintenance intervals may be required, such as: cleaning the fuel system and replacing fuel filters and fuel lines.
- Using biodiesel blended fuels containing more than five percent biodiesel can affect engine life and cause deterioration of hoses, tubelines, injectors, injector pump, and seals.

Apply the following guidelines if biodiesel blend fuel is used:

- Ensure the fuel tank is as full as possible at all times to prevent moisture from collecting in the fuel tank.
- Ensure that the fuel tank cap is securely tightened.
- Biodiesel blend fuel can damage painted surfaces, remove all spilled fuel from painted surfaces immediately.
- Drain all water from the fuel filter daily before operating the machine.
- Do not exceed engine oil change interval. Extended oil change intervals can cause engine damage.
- Before machine storage; drain the fuel tank, refill with 100% petroleum diesel fuel, add fuel stabilizer, and operate the engine for at least 30 minutes.

**NOTE: Biodiesel blend fuel does not have long term stability and should not be stored for more than 3 months.**

## LUBRICATING THE EXCAVATOR

### Lubrication Locations

Lubricate the excavator as specified in the SERVICE SCHEDULE for the best performance of the machine. (See SERVICE SCHEDULE on Page 10-70-1.)

Always use a good quality lithium based multipurpose grease when lubricating the machine. Apply the lubricant until extra grease shows.

Lubricate the following locations on the excavator **EVERY 8 - 10 HOURS**:

**Figure 10-140-1**

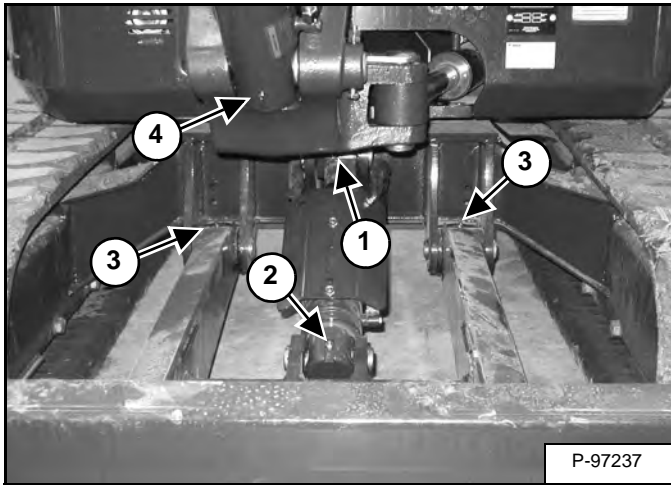

### Ref Description (# of Fittings)

1. Blade Cylinder Rod End (1) [Figure 10-140-1]
2. Blade Cylinder Base End (1) [Figure 10-140-1]
3. Blade Pivots (2) [Figure 10-140-1]
4. Boom Cylinder Base End (1) [Figure 10-140-1]

**Figure 10-140-2**

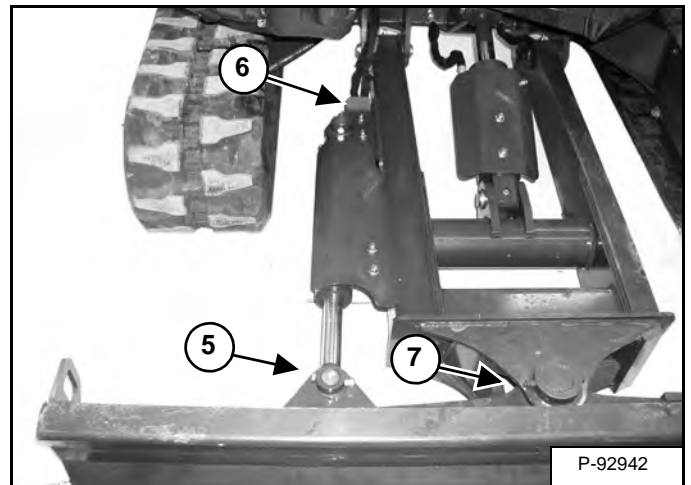

5. Angle Blade Cylinder Rod End (1) [Figure 10-140-2] (If equipped)
6. Angle Blade Cylinder Base End (1) [Figure 10-140-2] (If equipped)
7. Angle Blade Pivot (1) [Figure 10-140-2] (If equipped)

**Figure 10-140-3**

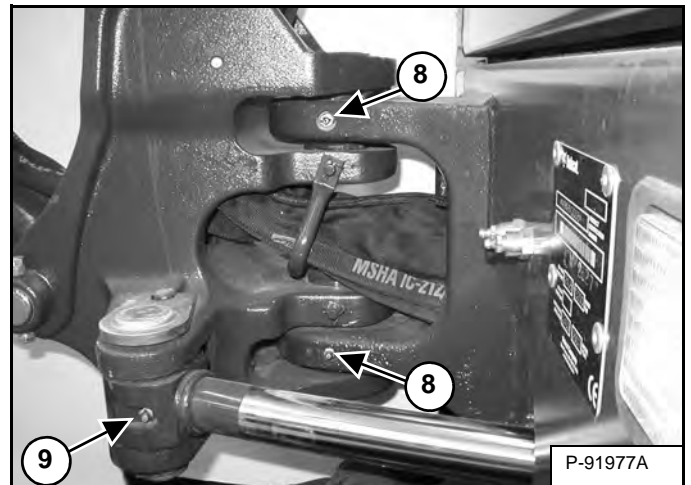

8. Boom Swing Pivot (2) [Figure 10-140-3]
9. Boom Swing Cylinder Rod End (1) [Figure 10-140-3]

## SEAT BELT

### Inspection And Maintenance

# WARNING

Failure to properly inspect and maintain the seat belt can cause lack of operator restraint resulting in serious injury or death.

W-2466-0703

Check the seat belt daily for correct function.

Inspect the seat belt system thoroughly at least once each year or more often if the machine is exposed to severe environmental conditions or applications.

Any seat belt system that shows cuts, fraying, extreme or unusual wear, significant discolorations due to ultraviolet UV exposure, dusty / dirty conditions, abrasion to the seat belt webbing, or damage to the buckle, latch plate, retractor (if equipped), hardware or any other obvious problem should be replaced immediately.

The items below are referenced in **[Figure 10-180-1]**.

1. Check the webbing. If the system is equipped with a retractor, pull the webbing completely out and inspect the full length of the webbing. Look for cuts, wear, fraying, dirt and stiffness.
2. Check the buckle and latch for correct operation. Make sure latch plate is not excessively worn, deformed or buckle is not damaged or casing broken.
3. Check the retractor web storage device (if equipped) by extending webbing to determine if it looks correct and that it spools out and retracts webbing correctly.
4. Check webbing in areas exposed to ultraviolet (UV) rays from the sun or extreme dust or dirt. If the original color of the webbing in these areas is extremely faded and / or the webbing is packed with dirt, the webbing strength may have deteriorated.

See a dealer for seat belt system replacement parts for your machine.

Figure 10-180-1

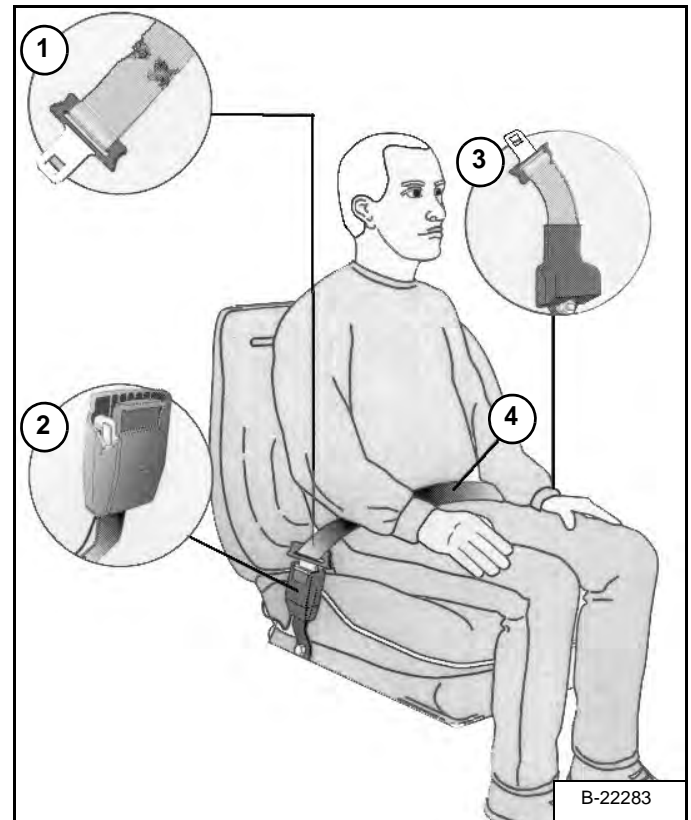

## **REMOTE START TOOL (SERVICE TOOL) KIT - 7217666**

### **Description**

The Remote Start Tool (Service Tool) Kit is a replacement tool for MEL1563 Remote Start Tool.

The Remote Start Tool (Service Tool) Kit, P/N 7217666, can be used to service excavators using the supplied harness P/N 6689747.

A computer can be connected to the Remote Start Tool (Service Tool) for diagnostics and software updates using the computer harness P/N 6689746 in conjunction with the excavator harness.

# E50 HYDRAULIC/HYDROSTATIC SCHEMATIC S/N AJ1811001 AND ABOVE

(PRINTED OCTOBER 2015)  
V-1509legend

## LEGEND

- |  |   |  |  |
|--|---|--|--|
| <p>① HYDRAULIC RESERVOIR: Pressurized with Fill Strainer<br/>Reservoir Capacity (at Site Gauge) . . . . .16.0 qt. (15.1 L)<br/>System Capacity . . . . .58.0 qt. (54.9 L)</p> <p>② PRESSURIZED BREATHER/FILL CAP with FILTER:<br/>6 PSI (0.4 bar) – Outlet<br/>0.6 PSI (0.04 bar) - Inlet</p> <p>③ HYDRAULIC FILTER ELEMENT<br/>15 Micron</p> <p>④ FILTER BY-PASS 50 PSI (3.44 bar)</p> <p>⑤ CASE DRAIN FILTER</p> <p>⑥ HYDRAULIC BY-PASS SWITCH</p> <p>⑦ HYDRAULIC PISTON PUMP . . . . .<br/>36.6 GPM (138,5 L/min.) at High Engine RPM</p> <p>⑧ PUMP MARGIN SPOOL -<br/>232 PSI (16 bar)</p> <p>⑨ TORQUE LIMITER</p> <p>⑩ PUMP CONTROLLER – Back-up Relief Valve<br/>3916 PSI (270 bar)</p> <p>⑪ ORIFICE: 0.026 inch (0,66 mm)</p> <p>⑫ ORIFICE: 0.031 inch (0,79 mm)</p> <p>⑬ PRESSURE SWITCH – Motion Alarm (If Equipped)</p> <p>⑭ SHUTTLE VALVE – Motion Alarm (If Equipped)</p> <p>⑮ PRESSURE REDUCING VALVE<br/>435 PSI (30 bar)</p> <p>⑯ CHECK VALVE - Accumulator</p> | <p>⑰ SOLENOID ACTIVATED DIRECTIONAL CONTROL VALVE – Boom Offset / Secondary Auxiliary Hydraulics – If Equipped)</p> <p>⑱ SOLENOID ACTIVATED DIRECTIONAL CONTROL VALVE – Boom Offset / Secondary Auxiliary Hydraulics – If Equipped)</p> <p>⑲ SOLENOID ACTIVATED DIRECTIONAL CONTROL VALVE - Two Speed</p> <p>⑳ SOLENOID ACTIVATED DIRECTIONAL CONTROL VALVE - Work group Lockout</p> <p>㉑ SOLENOID ACTIVATED DIRECTIONAL CONTROL VALVE – Angle Blade (If Equipped)</p> <p>㉒ SOLENOID ACTIVATED DIRECTIONAL CONTROL VALVE – Angle Blade (Optional)</p> <p>㉓ SOLENOID ACTIVATED DIRECTIONAL CONTROL VALVE - Male Coupler</p> <p>㉔ SOLENOID ACTIVATED DIRECTIONAL CONTROL VALVE - Female Coupler</p> <p>㉕ ACCUMULATOR</p> <p>㉖ FLUSHING VALVE 360 PSI (25 bar)</p> <p>㉗ LOAD SENSE BLEED CARTRIDGE<br/>0.185 GPM (0.70 L/min.)</p> <p>㉘ LOAD SENSE RELIEF VALVE<br/>3626 PSI (250 bar)</p> <p>㉙ FILTER – Control Valve</p> <p>㉚ PRESSURE SENSOR – Auto Idle</p> <p>㉛ COMPENSATOR</p> <p>㉜ PORT RELIEF VALVE (With Anti-Cavitation Valve) - (BUCKET Cylinder) 4206 PSI (290 bar)</p> <p>㉝ PORT RELIEF VALVE (With Anti-Cavitation Valve) - (BUCKET Cylinder) 4206 PSI (290 bar)</p> | <p>㉞ PORT RELIEF VALVE (With Anti-Cavitation Valve) - (ARM Cylinder) 4206 PSI (290 bar)</p> <p>㉟ PORT RELIEF VALVE (With Anti-Cavitation Valve) - (ARM Cylinder) 4206 PSI (290 bar)</p> <p>㊱ PORT RELIEF VALVE - (With Anti-Cavitation Valve) - (Auxiliary Pressure Port: 3045 PSI (210 bar)</p> <p>㊲ PORT RELIEF VALVE (With Anti-Cavitation Valve) - (Auxiliary Return Port: 3046 PSI (210 bar)</p> <p>㊳ PORT RELIEF VALVE (With Anti-Cavitation Valve) - (Boom Cylinder) 4206 PSI (290 bar)</p> <p>㊴ PORT RELIEF VALVE (With Anti-Cavitation Valve) - (Boom Cylinder) 4206 PSI (290 bar)</p> <p>㊵ PORT RELIEF VALVE (With Anti-Cavitation Valve) - (Blade Cylinder) 3771 PSI (260 bar)</p> <p>㊶ CHECK VALVE: 45 PSI (3,1 bar) With a 1,222 mm (0.045 in) Orifice</p> <p>㊷ CHECK VALVE: 60 PSI (4,2 bar)</p> <p>㊸ ORIFICE – Straight Travel 0.31 inch (0,8 mm)</p> <p>㊹ COUNTERBALANCE VALVE - With restrictors</p> <p>㊺ TWO SPEED SHIFT SPOOL</p> <p>㊻ CROSSPORT RELIEF VALVE – Travel Motor<br/>3810 PSI (263 bar)</p> <p>㊼ Not Used For This Model</p> <p>㊽ CHECK VALVE – Anti-Drain</p> <p>㊾ CROSSPORT RELIEF VALVE (Ramp Pressure Increasing Type):<br/>Set @: 3495 PSI (241 Bar)<br/>Crack Pressure: 1600 PSI (110 Bar)</p> <p>㊿ ANTI-CAVITATION VALVE (2)</p> <p>① PILOT ACTIVATED DIRECTIONAL CONTROL VALVE – Brake Release Valve<br/>57 PSI (3,9 bar)</p> <p>② TIMER VALVE – 363 PSI (25 bar) 3.7 Sec.</p> <p>③ ORIFICE</p> | <p>④ CHECK VALVE – Brake Release</p> <p>⑤ PILOT ACTIVATED DIRECTIONAL CONTROL VALVE - Second Auxiliary (Optional)</p> <p>⑥ SOLENOID ACTIVATED DIRECTIONAL CONTROL VALVE - Second Auxiliary (2) (Optional)</p> <p>⑦ PORT RELIEF VALVE (With Anti-Cavitation Valve) - (Secondary Auxiliary)<br/>4000 PSI (276 bar)</p> <p>⑧ PORT RELIEF VALVE (With Anti-Cavitation Valve) - (Secondary Auxiliary)<br/>4000 PSI (276 bar)</p> <p>⑨ TEST PORT - "JP3" PORT - Pressure Reducing Valve</p> <p>⑩ FACTORY FILL PORT</p> <p>⑪ TEST PORT (CAP)</p> <p>⑫ FILTER – Hydraulic X-Change Valve</p> <p>⑬ ORIFICE - 0.070 inch (1,78 mm)</p> <p>⑭ CHECK VALVE – Load Sense</p> <p>⑮ SOLENOID ACTIVATED DIRECTIONAL CONTROL VALVE (TWO COIL)</p> <p>⑯ CHECK VALVE</p> <p>⑰ CHECK VALVE With 0.009 in. (0,23 mm) Orifice (Optional)</p> <p>⑱ ANTI-CAVITATION VALVE</p> <p>⑲ TEST PORT – LS PORT</p> <p>⑳ PORT RELIEF VALVE (With Anti-Cavitation Valve) - (Angle Blade) 3916 PSI (270 bar)</p> <p>㉑ PORT RELIEF VALVE (With Anti-Cavitation Valve) - (Angle Blade) 3916 PSI (270 bar)</p> <p>㉒ TEST PORT – "P" PORT (Manifold)</p> |
|--|---|--|--|

**NOTE:** Unless otherwise specified springs have NO significant pressure value.

## CYLINDER (BOOM)

### Testing

Lower the work group to the ground.

With the engine off, turn the key to the ON position and move both hydraulic control levers to relieve hydraulic pressure.

**Figure 20-20-1**

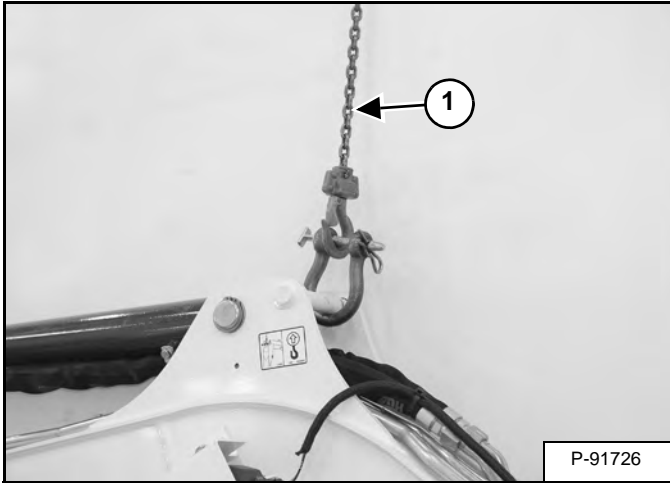

Support the boom with a chain hoist (Item 1) [Figure 20-20-1].

**Figure 20-20-2**

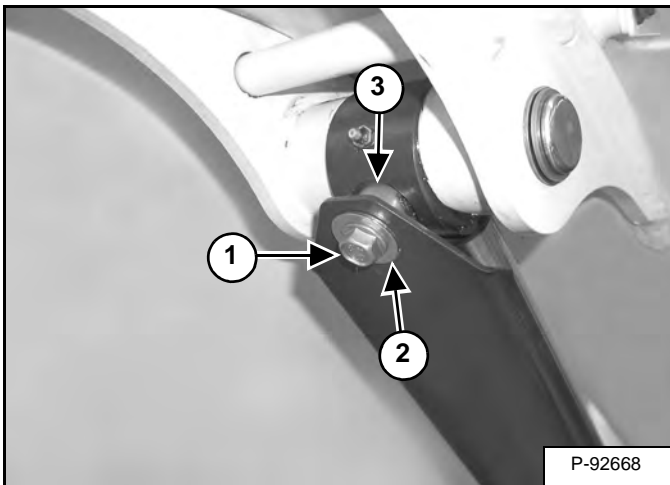

Remove the boom shield bolt (Item 1), washer (Item 2), spring washer and spacer (Item 3) [Figure 20-20-2].

**Figure 20-20-3**

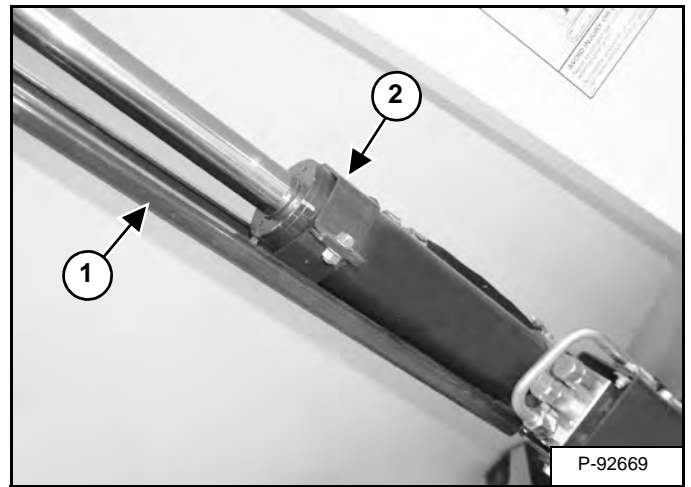

Slide the shield (Item 1) off of the bracket (Item 2) [Figure 20-20-3].

**Figure 20-20-4**

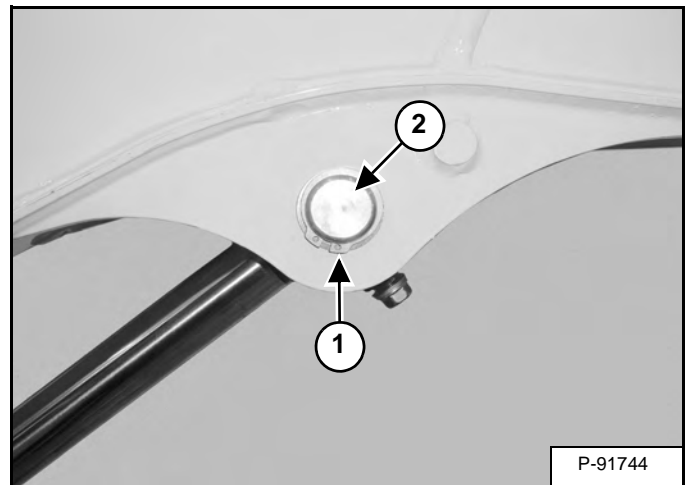

Remove the snap ring (Item 1) [Figure 20-20-4] and washer.

Remove the rod end pin (Item 2) [Figure 20-20-4].

## CYLINDER (BOOM) (CONT'D)

### Assembly (Cont'd)

Figure 20-20-28

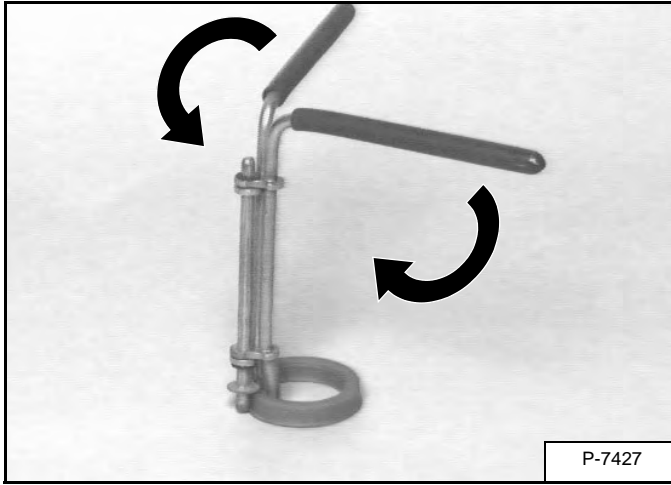

Install the rod seal on the rod seal tool [Figure 20-20-28].

**NOTE:** During installation the spring side of the seal must be toward the inside of the cylinder.

Rotate the handles to collapse the rod seal [Figure 20-20-28].

Figure 20-20-29

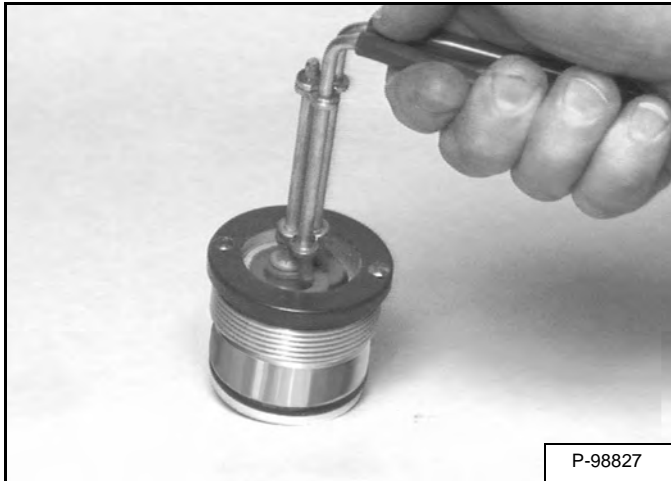

Install the rod seal in the head [Figure 20-20-29].

Figure 20-20-30

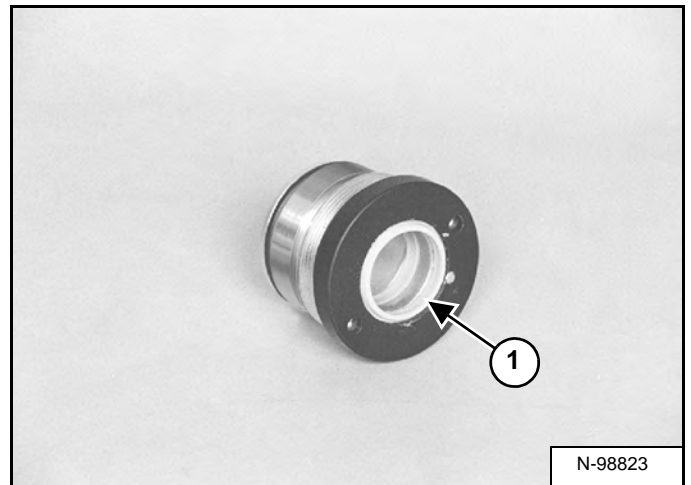

Install the wiper seal with the wiper (Item 1) [Figure 20-20-30] toward the outside of the head.

Figure 20-20-31

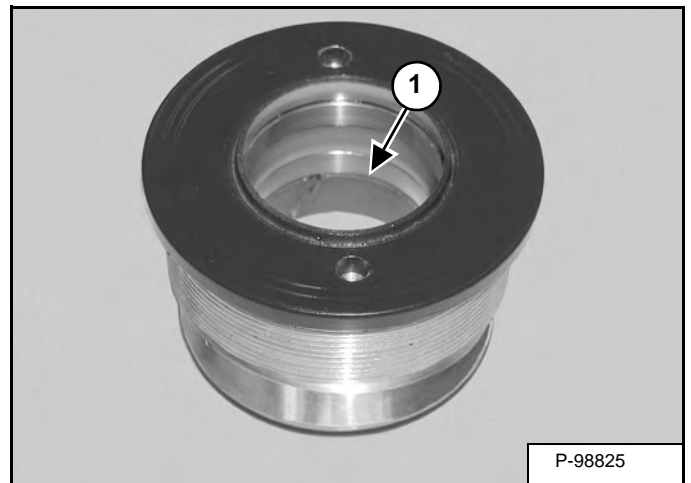

Install the wear ring (Item 1) [Figure 20-20-31].

## CYLINDER (ARM) (CONT'D)

### Disassembly (Cont'd)

Figure 20-21-17

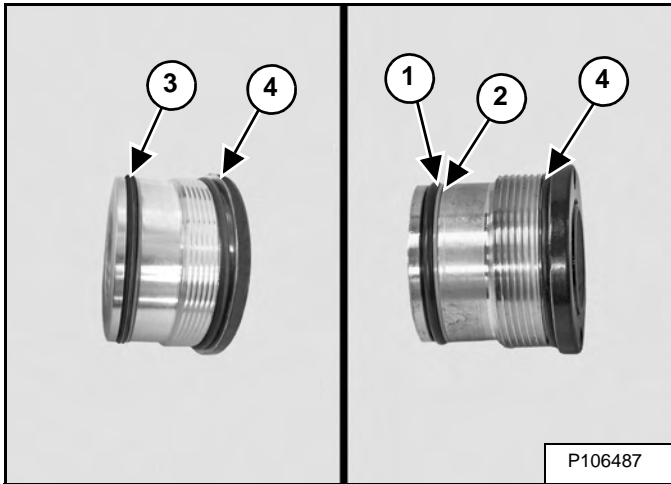

Remove the O-ring (Item 1) and the back-up ring (Item 2) or seal (Item 3) [Figure 20-21-17].

**NOTE:** The seal kit may contain the O-ring / back-up ring or seal.

Remove the O-ring (Item 4) [Figure 20-21-17].

Figure 20-21-18

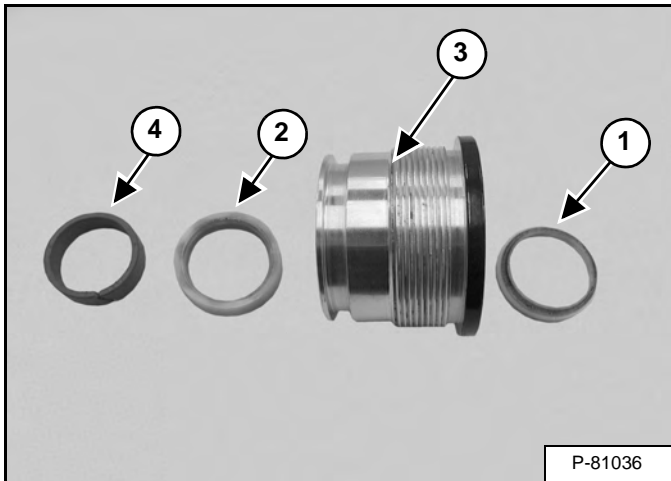

Remove the wiper seal (Item 1) and rod seal (Item 2) from the inside of the head (Item 3) [Figure 20-21-18].

Remove the wear ring (Item 4) [Figure 20-21-18].

Figure 20-21-19

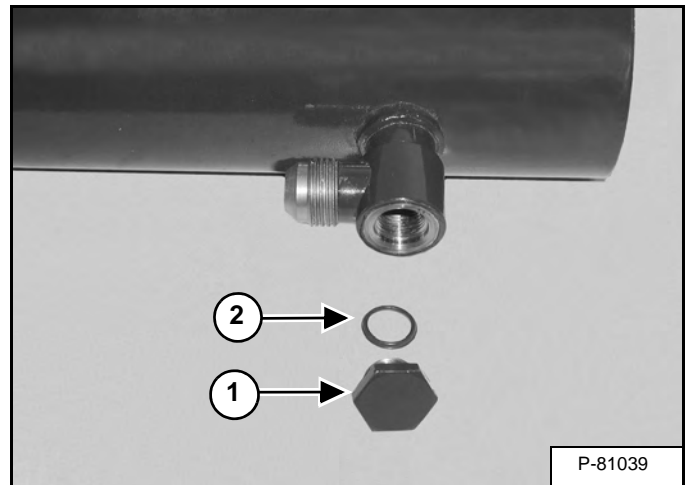

Remove plug (Item 1) and O-ring (Item 2) [Figure 20-21-19].

Figure 20-21-20

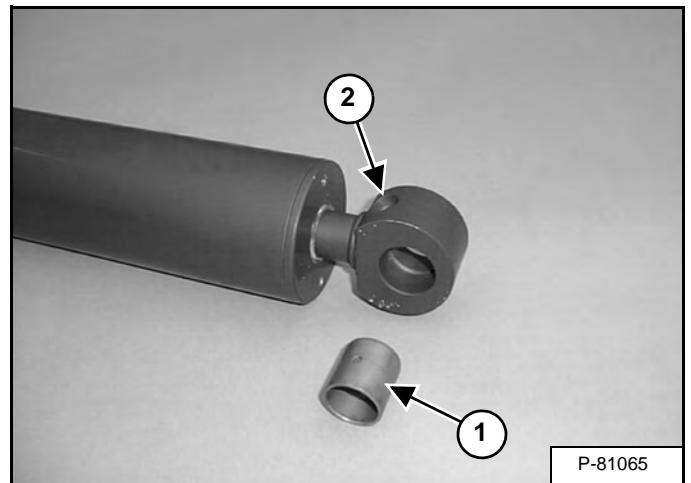

Remove the seals bushing (Item 1) [Figure 20-21-20].

Replace the grease fitting (Item 2) [Figure 20-21-20] if damaged or missing.

## CYLINDER (BOOM SWING) (CONT'D)

### Removal And Installation (Cont'd)

Figure 20-22-14

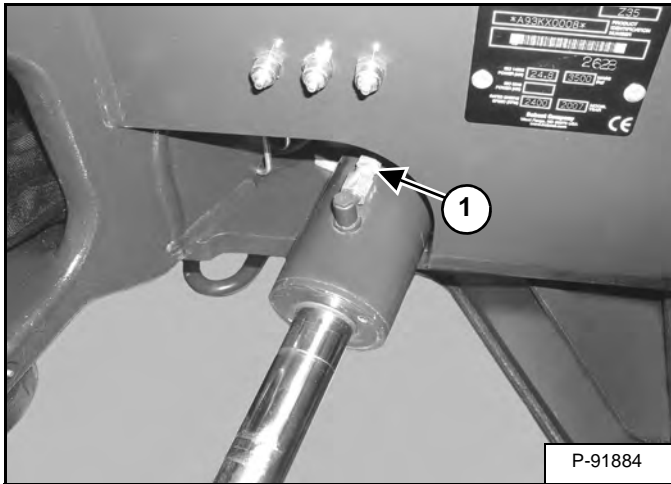

Remove the hose (Item 1) [Figure 20-22-14].

Remove the cylinder.

## CYLINDER (BUCKET) (CONT'D)

### Removal And Installation

Lower the work group to the ground.

With the engine off, turn the key to the ON position and move both hydraulic control levers to relieve hydraulic pressure.

**Figure 20-23-6**



Support the boom using a chain hoist [Figure 20-23-6].

**Figure 20-23-7**

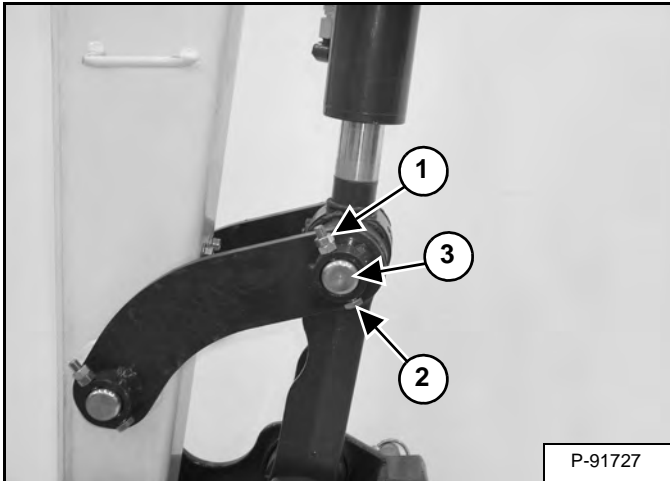

Remove the nuts (Item 1) and bolt (Item 2) [Figure 20-23-7].

Remove the pin (Item 3) [Figure 20-23-7].

**Figure 20-23-8**

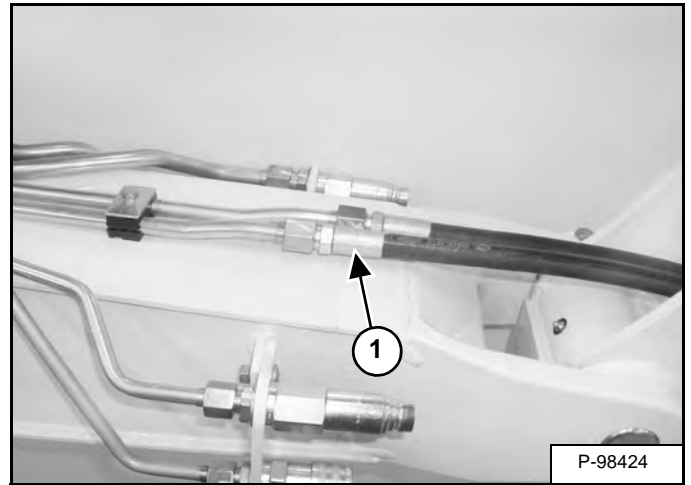

Remove the base end hose (Item 1) [Figure 20-23-8].

**NOTE:** The hose will be removed with the cylinder.

**Figure 20-23-9**

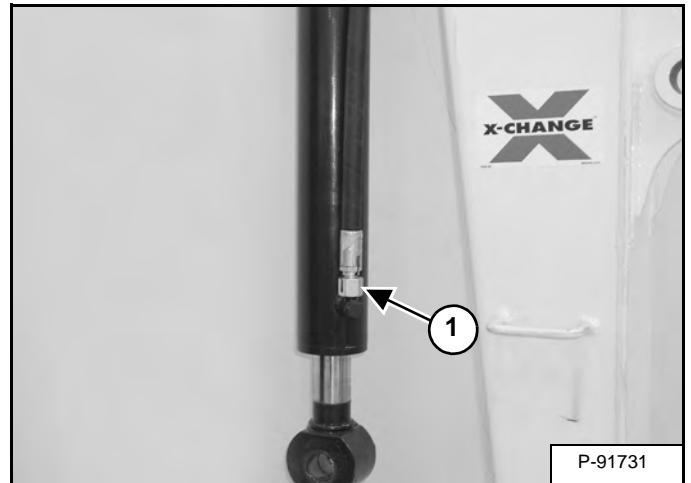

Remove the hose (Item 1) [Figure 20-23-9].

## CYLINDER (BLADE) (CONT'D)

### Removal And Installation

Lower the work group to the ground.

Stop the engine. With the key in the ON position, move the blade control to release the hydraulic pressure. Raise the control console.

Figure 20-24-7

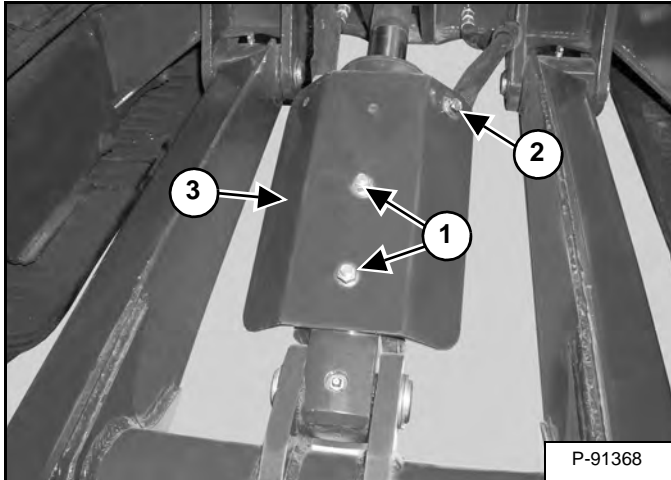

Remove the two nuts (Item 1) [Figure 20-24-7] from the studs.

Remove the bolt (Item 2) [Figure 20-24-7] and nut from the cylinder shields.

Remove the shield (Item 3) [Figure 20-24-7].

Figure 20-24-8

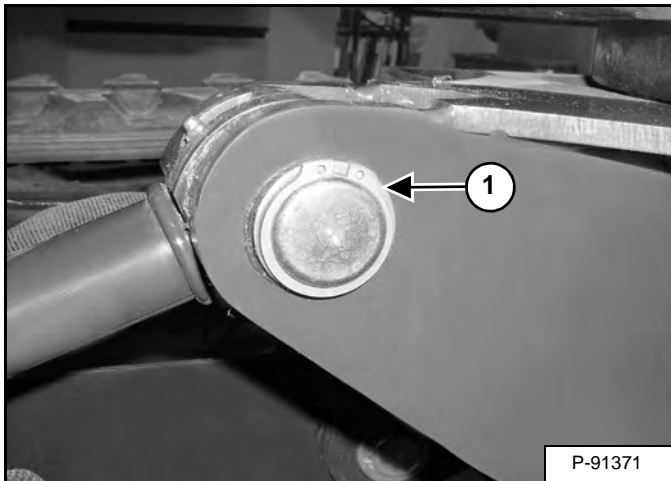

Remove the snap ring (Item 1) [Figure 20-24-8] and washer from the cylinder rod end.

Figure 20-24-9

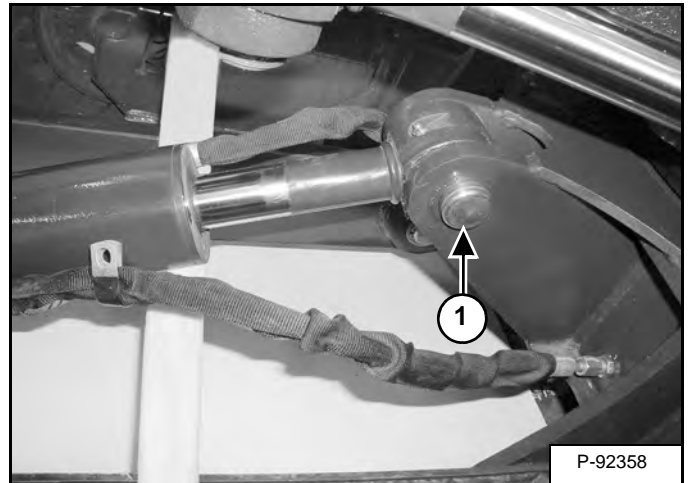

Support the cylinder and remove the pin (Item 1) [Figure 20-24-9].

Figure 20-24-10

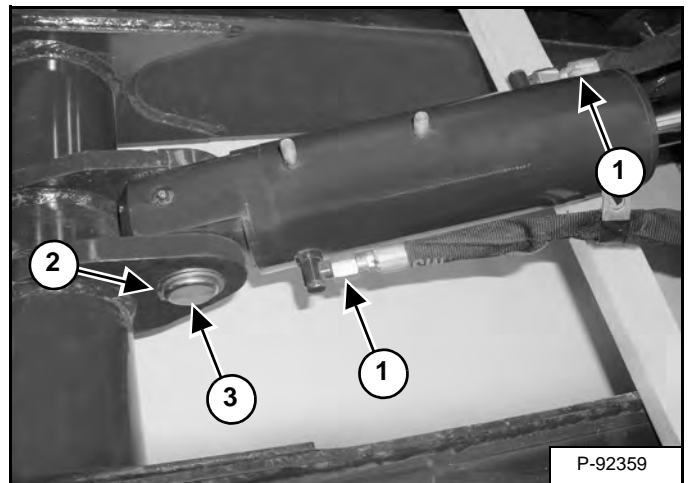

Remove the hoses (Item 1) [Figure 20-24-10].

Remove the base end snap ring and washer (Item 2) [Figure 20-24-10].

Remove the base end pin (Item 3) [Figure 20-24-10] and remove the blade cylinder.

## IMPORTANT

When repairing hydrostatic and hydraulic systems, clean the work area before disassembly and keep all parts clean. Always use caps and plugs on hoses, tubelines and ports to keep dirt out. Dirt can quickly damage the system.

I-2003-0888

## CYLINDER (CLAMP) (CONT'D)

### Removal And Installation (Cont'd)

Figure 20-25-8

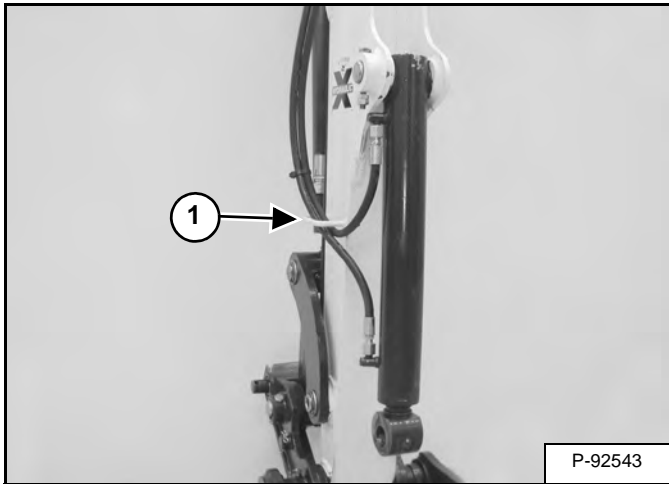

Remove the hoses from the bottom hose guide (Item 1) [Figure 20-25-8].

Figure 20-25-9

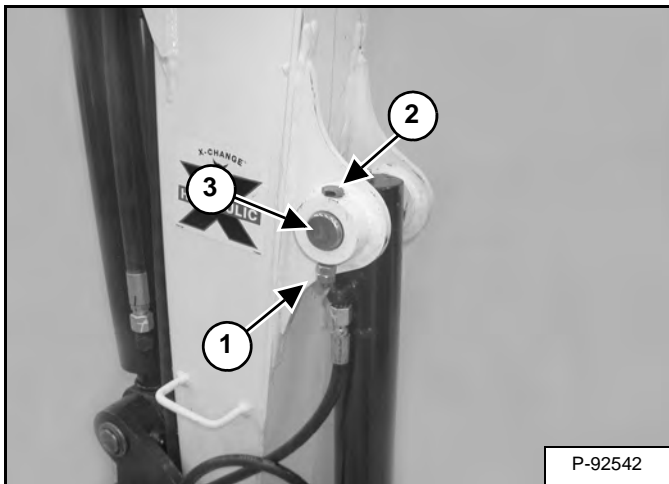

Remove the nuts (Item 1) and bolt (Item 2) [Figure 20-25-9].

Remove the pin (Item 3) [Figure 20-25-9] and remove the cylinder.

## CYLINDER (ANGLE BLADE)

### Testing

Lower the work equipment to the ground.

With the engine off, turn the key to the ON position, lower the console and move the blade lever. Press and hold the two speed button to activate angle blade mode, move the lever again to relieve hydraulic pressure.

**Figure 20-26-1**

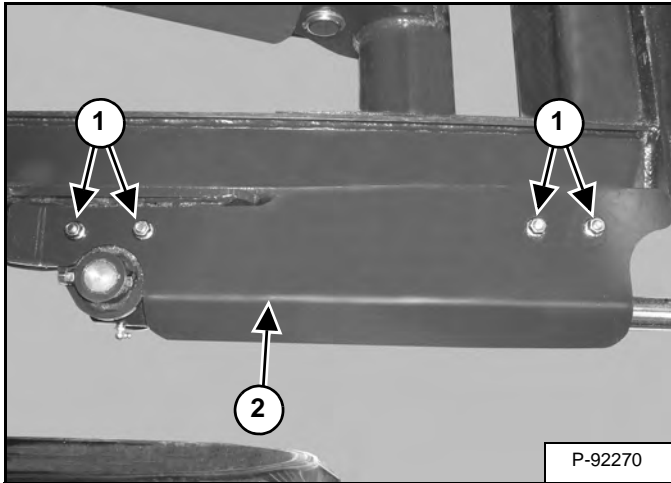

Remove the nuts (Item 1) and shield (Item 2) [Figure 20-26-1].

**Figure 20-26-2**

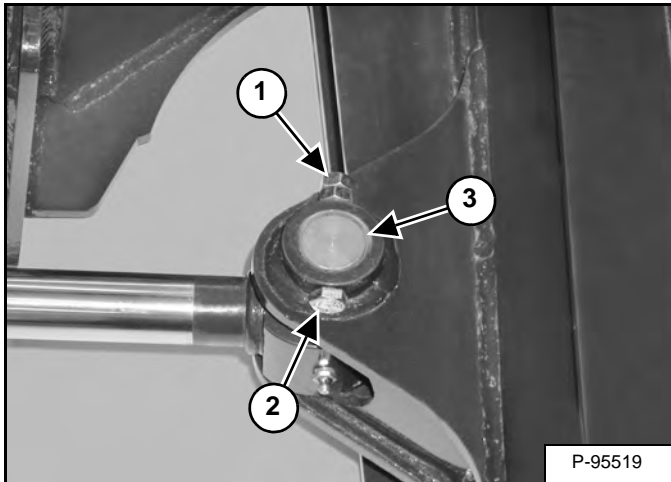

Remove the nuts (Item 1), bolt (Item 2) and pin (Item 3) [Figure 20-26-2] from the rod end of the angle blade cylinder.

Start the engine and retract the angle blade cylinder.

With the engine off, turn the key to the ON position and move the blade lever to relieve hydraulic pressure.

Stop the engine.

**Figure 20-26-3**

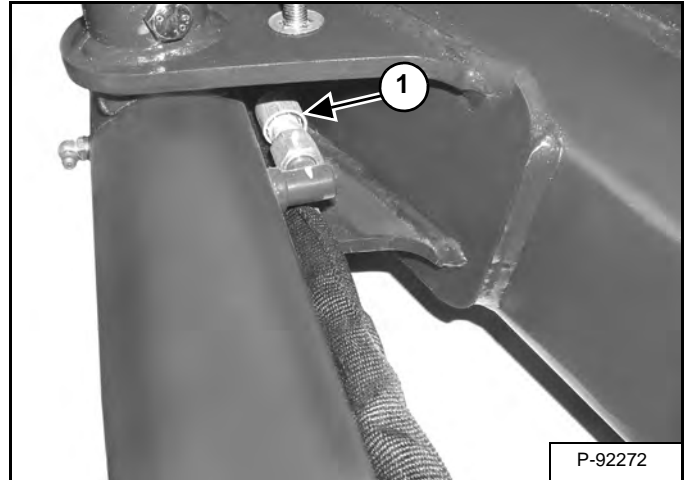

Reposition the cylinder and remove the hose (Item 1) [Figure 20-26-3] from the base end of the angle blade cylinder.

Install a plug in the hose.

Start the engine, and retract the angle blade cylinder.

**Figure 20-26-4**

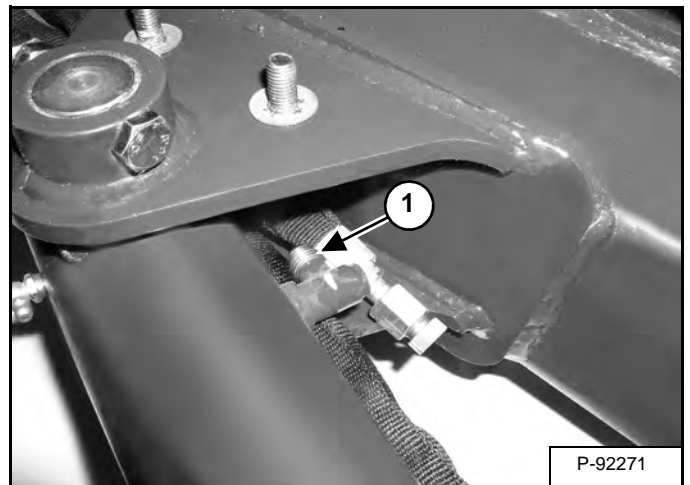

If there is any leakage from the base end fitting (Item 1) [Figure 20-26-4], remove the cylinder for repair or replacement.

## **VALVE (MAIN RELIEF)**

### **Testing And Adjusting**

The E50 excavator does not have a main relief valve, which can be removed or adjusted. The system pressure is regulated by several components within the hydraulic system. For pressure adjustment, go to the Hydraulic Pump (See HYDRAULIC PUMP on Page 20-50-1.)

## HYDRAULIC CONTROL VALVE

### Description

The hydraulic control valve is a ten section closed center system and has one load sense relief valve. The load sense relief valve operates at 25000 kPa (250 bar) (3626 psi). The bucket, arm and boom sections have 28999 kPa (290 bar) (4206 psi) work port reliefs.

The auxiliary section has 20995 kPa (210 bar) (3045 psi) work port reliefs.

The angle blade section has a 27000 kPa (270 bar) (3916 psi) work port relief.

The blade section has one 26000 kPa (260 bar) (3771 psi) work port relief operating on the base end of the blade cylinder.

### Removal And Installation

Lower the work equipment to the ground.

Stop the engine.

With the engine off, turn the start key to the ON position and move both hydraulic control levers to relieve hydraulic pressure.

Remove the hydraulic reservoir. (See Removal And Installation on Page 20-140-1.)

Remove the right upperstructure cover. (See Removal And Installation on Page 40-80-1.)

## IMPORTANT

**When repairing hydrostatic and hydraulic systems, clean the work area before disassembly and keep all parts clean. Always use caps and plugs on hoses, tubelines and ports to keep dirt out. Dirt can quickly damage the system.**

I-2003-0888

Figure 20-40-1

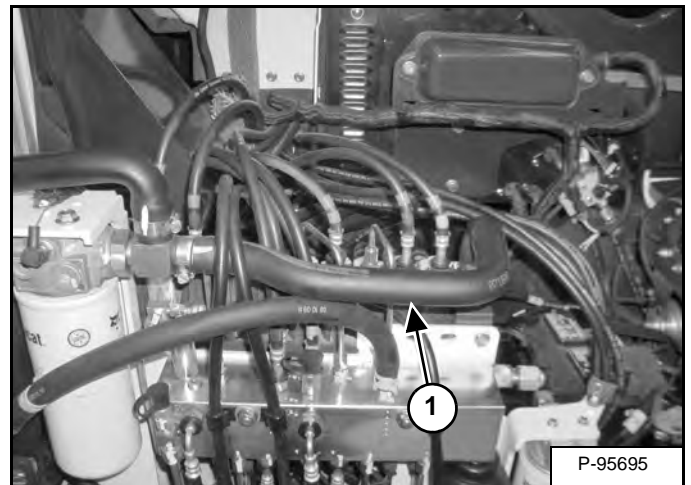

Remove the return hose (Item 1) [Figure 20-40-1].

**Installation:** Tighten the hose clamps to 6,21 N•m (55 in-lb) torque.

Mark all tubelines and hoses for proper installation.

Figure 20-40-2

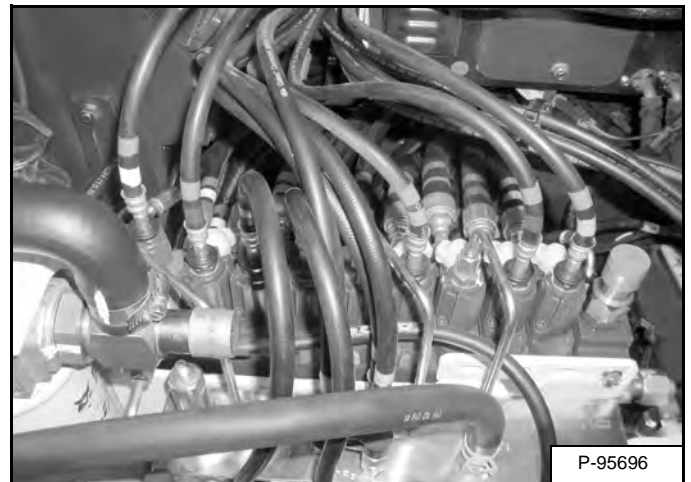

Remove the pilot pressure hoses and tubelines from the top of the valve [Figure 20-40-2].

## HYDRAULIC CONTROL VALVE (CONT'D)

### Inlet Valve Section Disassembly And Assembly (Cont'd)

Figure 20-40-30

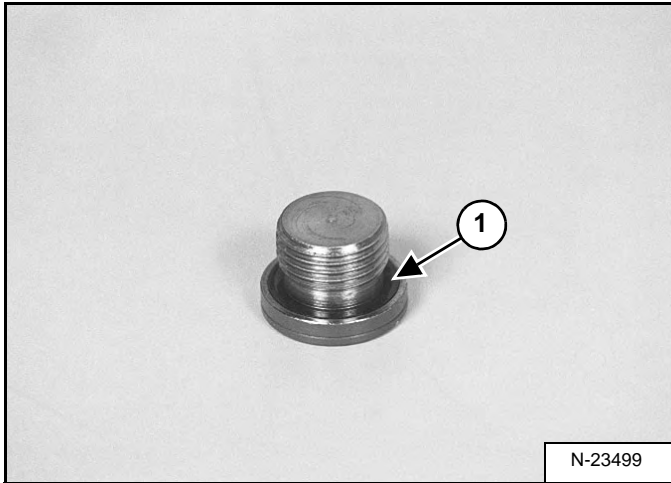

Remove the O-ring (Item 1) [Figure 20-40-30].

Figure 20-40-31

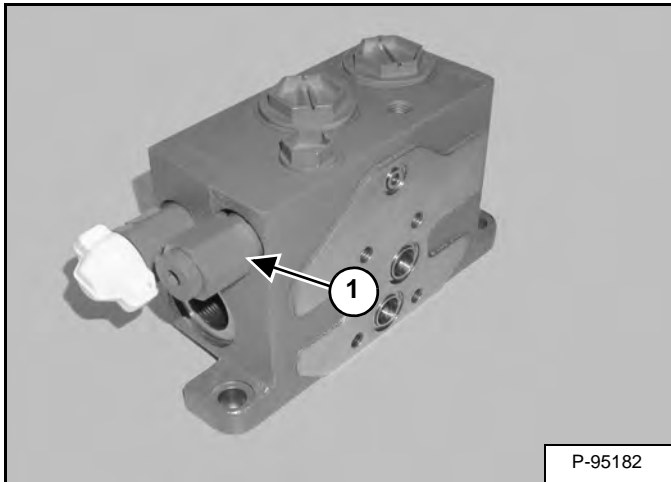

Remove the load sense bleed valve (Item 1) [Figure 20-40-31] from the Inlet section.

**Assembly:** Tighten the load sense bleed valve to 18 - 20 N•m (13 - 16 ft-lb) torque.

Figure 20-40-32

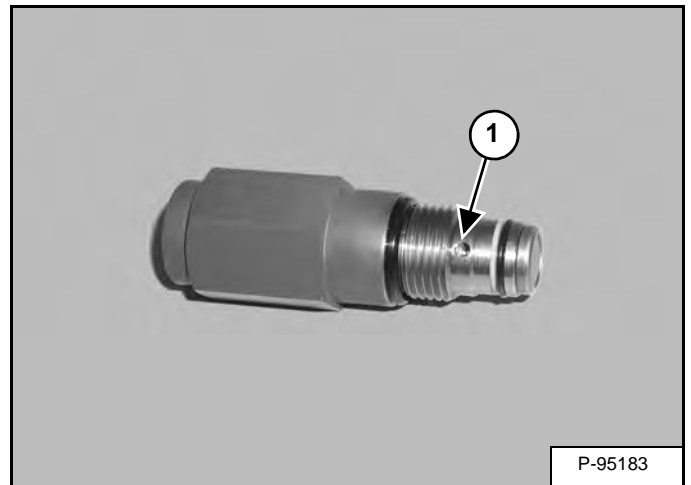

Check that the port (Item 1) [Figure 20-40-32] in the load sense bleed valve is not plugged.

Figure 20-40-33

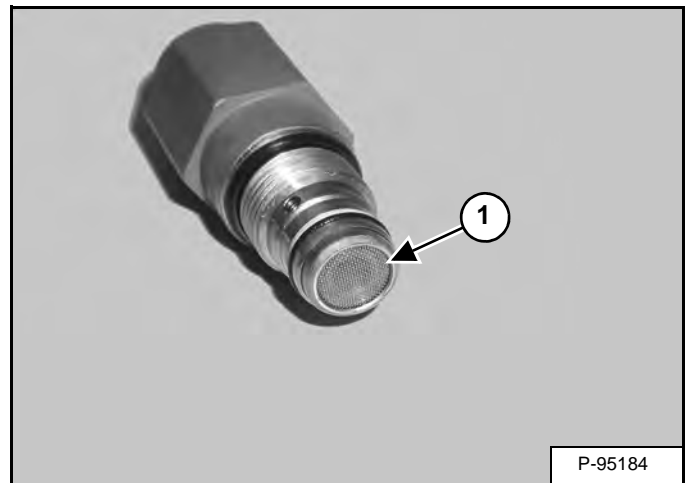

Check the filter (Item 1) [Figure 20-40-33] at the end of the load sense bleed valve.

## HYDRAULIC CONTROL VALVE (CONT'D)

### Blade Valve Section Disassembly And Assembly

Figure 20-40-62

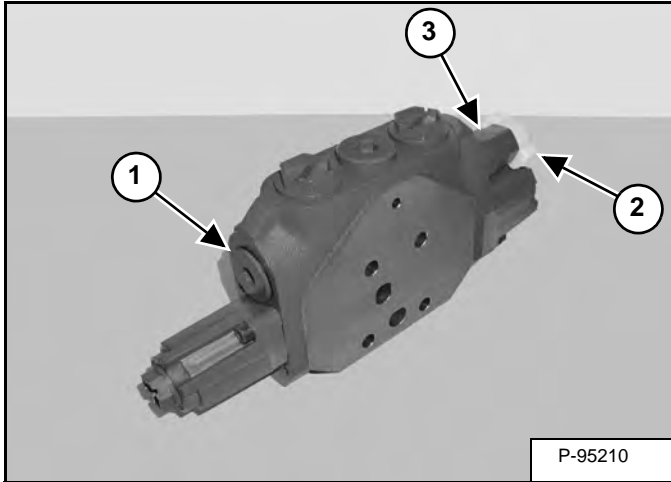

Remove the plug (Item 1) and cover (Item 2). Remove the port relief (Item 3) [Figure 20-40-62].

**Assembly:** Tighten the plug and port relief to 63 - 77 N•m (46 - 57 ft-lb) torque.

Figure 20-40-63

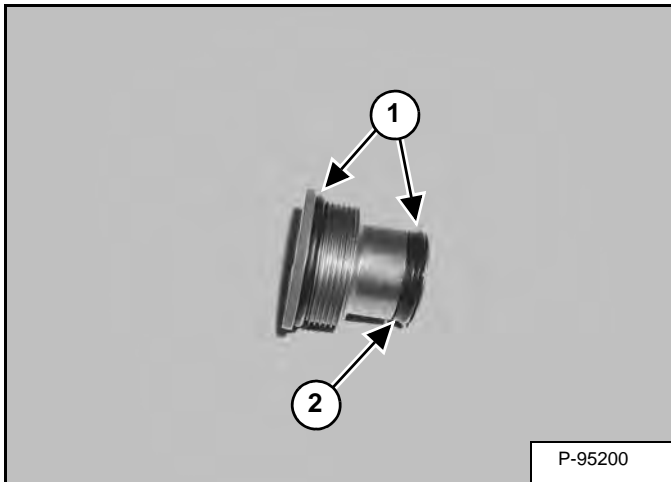

Remove the O-rings (Item 1) and back-up ring (Item 2) [Figure 20-40-63].

Figure 20-40-64

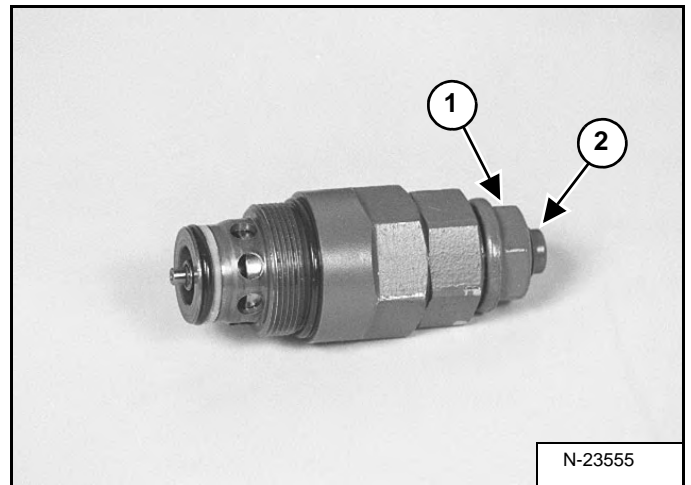

Remove the nut (Item 1) and adjustment screw (Item 2) [Figure 20-40-64].

Figure 20-40-65

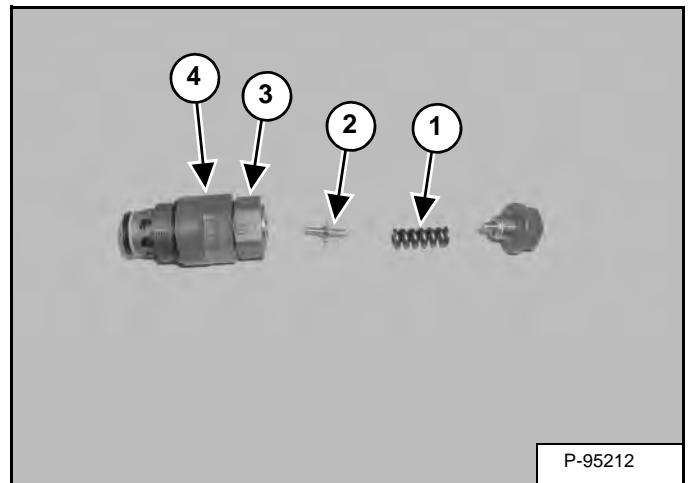

Remove the spring (Item 1), poppet (Item 2) and nut (Item 3) from the front housing (Item 4) [Figure 20-40-65].

## HYDRAULIC PUMP

### Hydraulic Pump Work Sheet

(Please review pump procedure as illustrated in "Pump Testing". (See Pump Testing on Page 20-50-4.)

The outline listed below, gives the six adjustments for setting the hydraulic pump. The adjustments are listed in the order in which they **MUST** be performed. Below each adjustment is a list of the steps. Behind each adjustment is the page location within the Service Manual for the complete adjustment procedure.

1. Run engine at High Idle. Record no load engine rpm. (See Engine on Page SPEC-10-6.)

#### **I. Test Fitting Installation.** (See Test Fitting Installation on Page 20-50-4.)

2. Remove the plug from the valve. Install the coupler and the return hose from the hydraulic tester to the return fitting on the control valve.
3. Remove the cap from the valve and install the inlet hose from the tester to the fitting on the hydraulic control valve.
4. Install the jumper hose on the load sense test port and pump pressure test port.
5. With the engine at High Idle, turn the hydraulic tester flow control clockwise until 6895 kPa (69 bar) (1000 psi) is shown on the gauge. Restrict the oil until it is at a minimum of 66°C (150°F).
6. Turn the hydraulic tester flow control counter clockwise until all restriction is removed.

\_\_\_\_\_ **ENGINE RPM**

#### **II. Minimum Displacement Adjustment.** (See Minimum Displacement Adjustment on Page 20-50-6.)

7. Disconnect the load sense hose at the pump. Plug the hose and install a hose from the hydraulic load sense fitting to the reservoir.
8. Run engine at High Idle.
9. Adjust hydraulic tester to 9653 - 10342 kPa (97 - 103 bar) (1400 - 1500 psi), pump flow should be 9,5 - 17 L/min (2.5 - 4.5 U.S. gpm).
10. Record the flow.

\_\_\_\_\_ **FLOW**

11. Adjust the minimum displacement adjustment stop screw at the pump as needed.
12. At the manifold, disconnect the hose from the pump diagnostic port to the load sense diagnostic port.

## HYDRAULIC PUMP (CONT'D)

### Pump Testing (Cont'd)

#### Torque Limiter Adjustment (Cont'd)

Figure 20-50-25

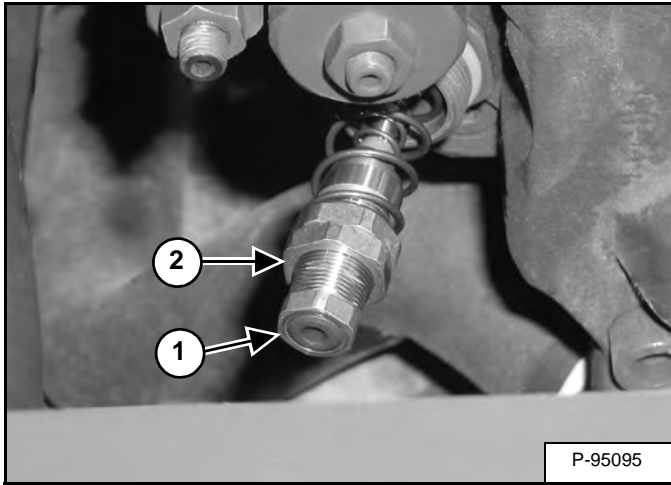

Check that the small nut (Item 1) [Figure 20-50-25] is locked in place.

Adjust the flow at the hydraulic pump torque limiter loosening the front large nut (Item 2) [Figure 20-50-25]. With a hex wrench adjust the *flow at low pressure*.

Reinstall the cap on the hydraulic pump torque limiter and tighten.

Start the engine and retest the flow rate.

When the proper flow is obtained, **98,4 - 113,5 L/min (26 - 30 U.S. gpm) at 13031 kPa (130 bar) (1890 psi)**, tighten the large nut (Item 2) [Figure 20-50-25].

**NOTE: When adjusting the flow at low pressure, the engine rpm must not fall below 2200 rpm.**

If this flow at low pressure cannot be obtained, remove and replace the torque limiter spool assembly.

Figure 20-50-26

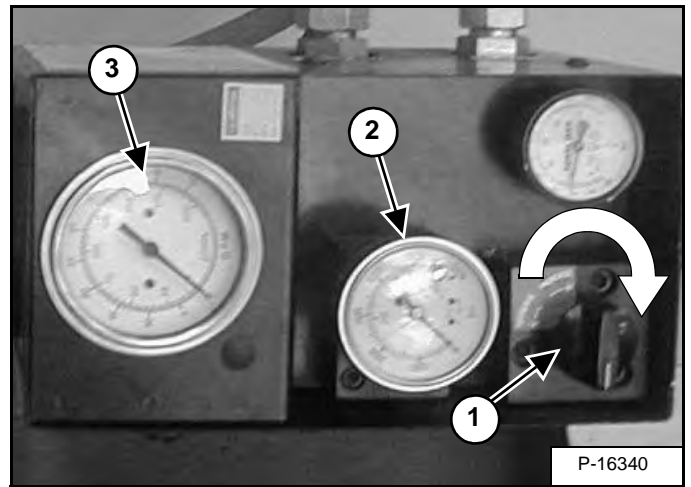

Turn the hydraulic tester flow control (Item 1) clockwise until the gauge (Item 2) reads **22753 kPa (228 bar) (3300 psi)**. Record the amount of flow at the tester gauge (Item 3) [Figure 20-50-26], which is the *flow at high pressure*.

The flow should be approximately **49 - 54 L/min (13 - 17 U.S. gpm)**.

Figure 20-50-27

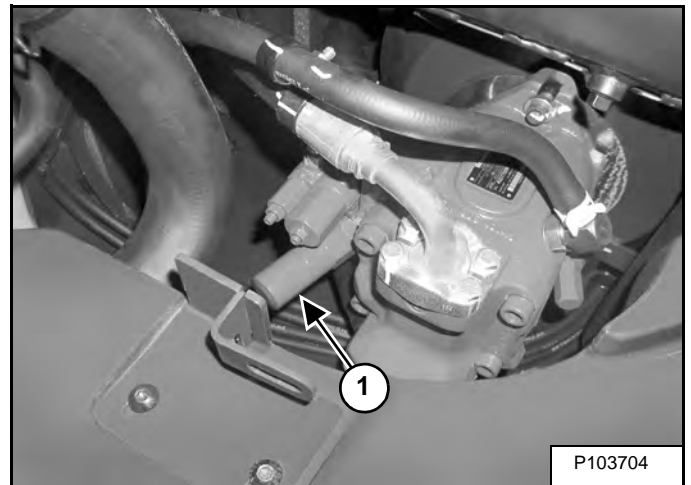

If the flow at high pressure must be adjusted, adjust the flow at the hydraulic pump torque limiter. Stop the engine, remove the torque limiter cover (Item 1) [Figure 20-50-27].

## HYDRAULIC PUMP (CONT'D)

### Pump Control Disassembly And Assembly (Cont'd)

#### Back-up Relief Valve (Cont'd)

Figure 20-50-50

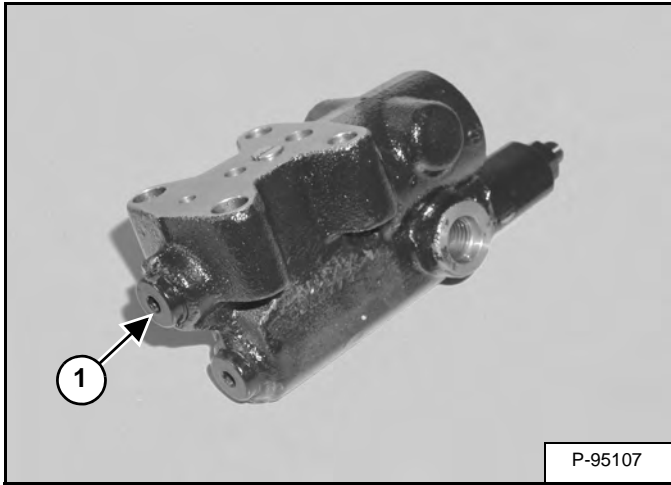

Remove the plug (Item 1) [Figure 20-50-50] from the back-up relief valve on the pump control.

Figure 20-50-51

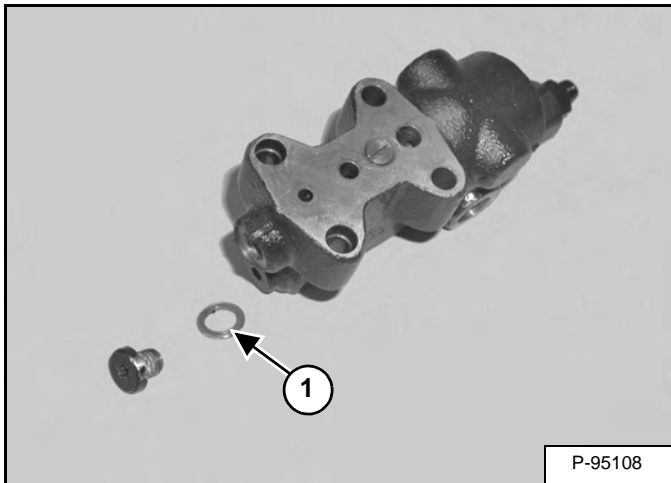

Check the O-ring washer (Item 1) [Figure 20-50-51] and replace as needed.

## Pump Margin Control

Figure 20-50-52

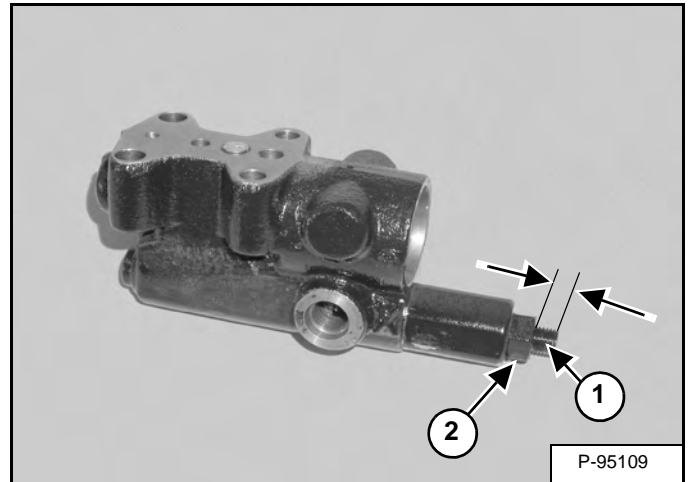

Before disassembling the pump margin control, measure the adjustment screw (Item 1) [Figure 20-50-52] thread length for the correct initial adjustment.

Remove the nut (Item 2) [Figure 20-50-52].

Figure 20-50-53

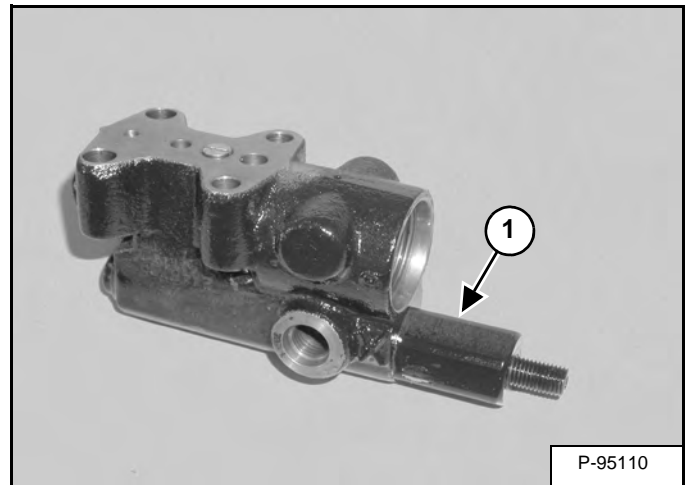

Remove the margin control assembly (Item 1) [Figure 20-50-53].

## HYDRAULIC PUMP (CONT'D)

### Disassembly And Assembly (Cont'd)

Figure 20-50-85

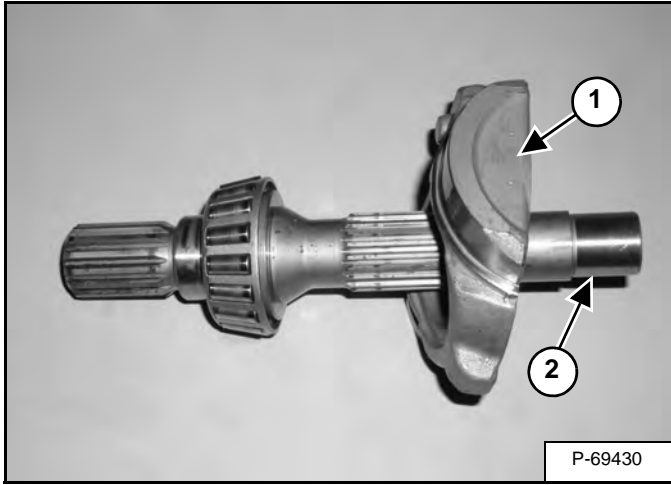

Remove the swash plate (Item 1) from the shaft (Item 2) [Figure 20-50-85].

Figure 20-50-86

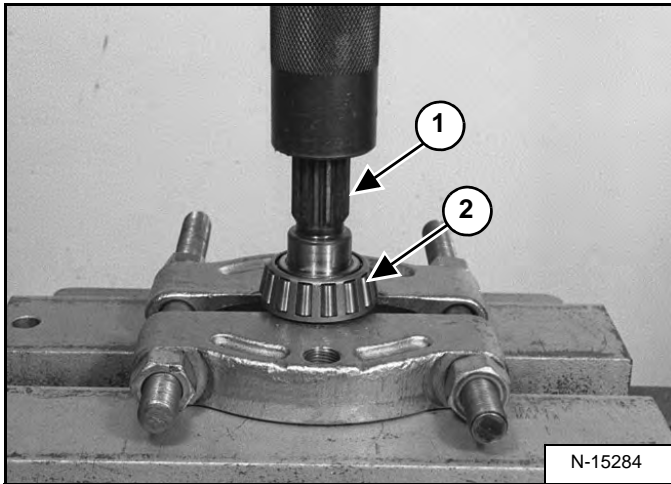

Press the shaft (Item 1) off the bearing (Item 2) [Figure 20-50-86].

Figure 20-50-87

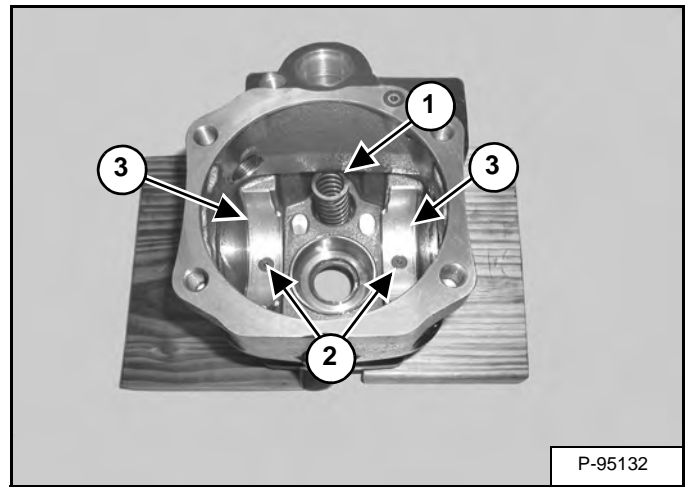

Stand the hydraulic pump vertically and remove the spring (Item 1) [Figure 20-50-87] from the pump housing.

Remove the screws (Item 2) and brass bearings (Item 3) [Figure 20-50-87] from the pump housing.

Figure 20-50-88

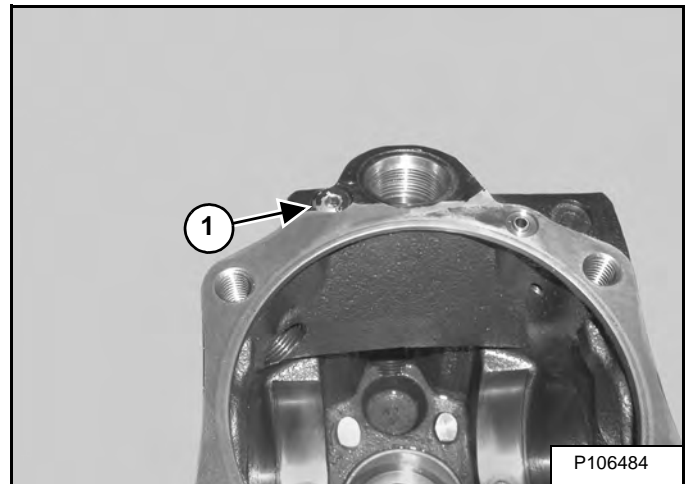

Remove the plug (Item 1) [Figure 20-50-88].

# MANIFOLD ASSEMBLY / ACCUMULATOR (WITHOUT ANGLE BLADE) (CONT'D)

## Disassembly And Assembly (Cont'd)

Figure 20-60-25

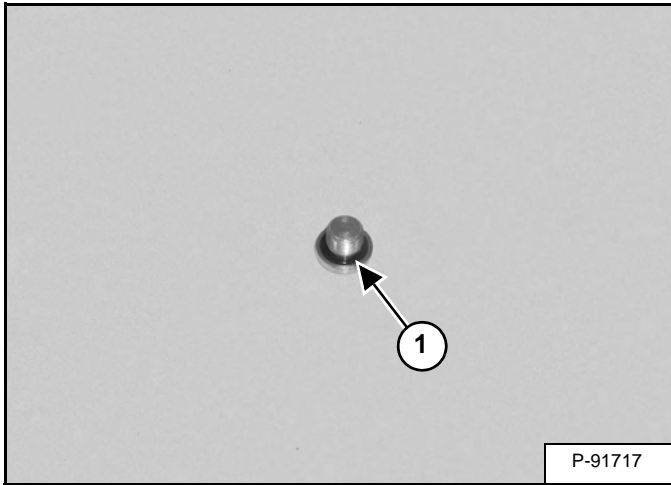

Remove the O-ring (Item 1) [Figure 20-60-25] from the plug.

Figure 20-60-26

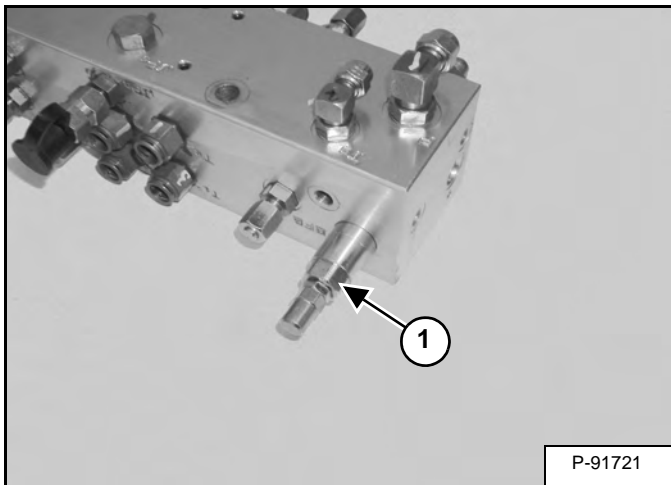

Remove the pilot relief valve (Item 1) [Figure 20-60-26].

**Installation:** Tighten the pilot relief valve to 30 N•m (22 ft-lb) torque.

Figure 20-60-27

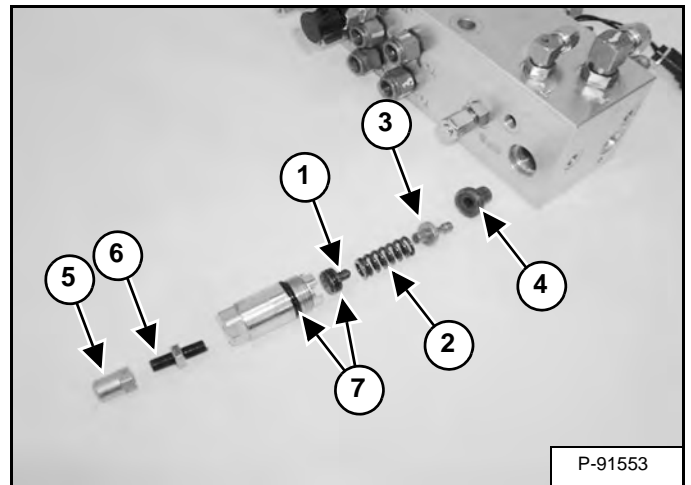

Remove the spring seat (Item 1), spring (Item 2), spring seat (Item 3) and seat (Item 4). Remove the cap (Item 5) and remove the adjustment screw (Item 6). Remove the O-rings (Item 7) [Figure 20-60-27].

Clean all parts in solvent and dry with compressed air.

Always install new seals and O-rings. Lubricate all seals and O-rings with clean hydraulic fluid before installation.

Inspect all parts for wear or damage. Replace any worn or damaged parts.

## MANIFOLD ASSEMBLY / ACCUMULATOR (WITH ANGLE BLADE) (CONT'D)

### Disassembly And Assembly (Cont'd)

Figure 20-61-25

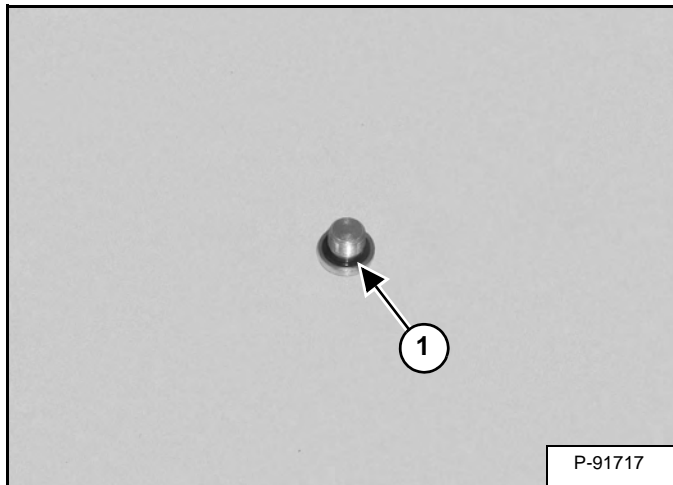

Remove the O-ring (Item 1) [Figure 20-61-25] from the plug.

Figure 20-61-26

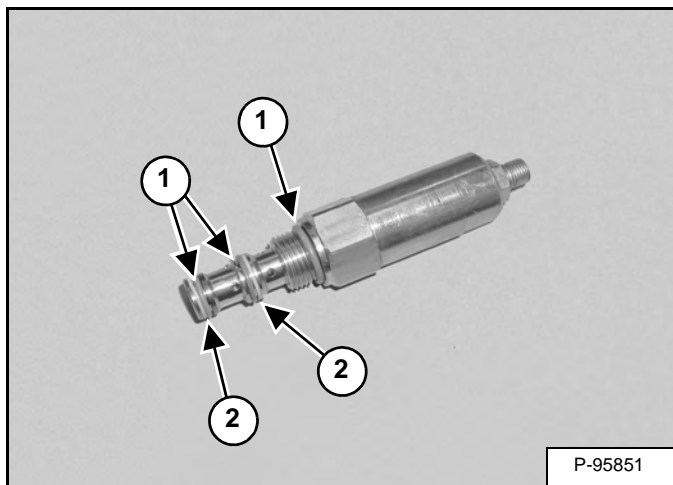

Remove the O-rings (Item 1) and back-up rings (Item 2) [Figure 20-61-26].

Clean all parts in solvent and dry with compressed air.

Inspect all parts for wear or damage. Replace any worn or damaged parts.

Always install new seals and O-rings. Lubricate all seals and O-rings with clean hydraulic fluid before installation.

## TRAVEL MOTOR (CONT'D)

### Disassembly (Cont'd)

Figure 20-70-23

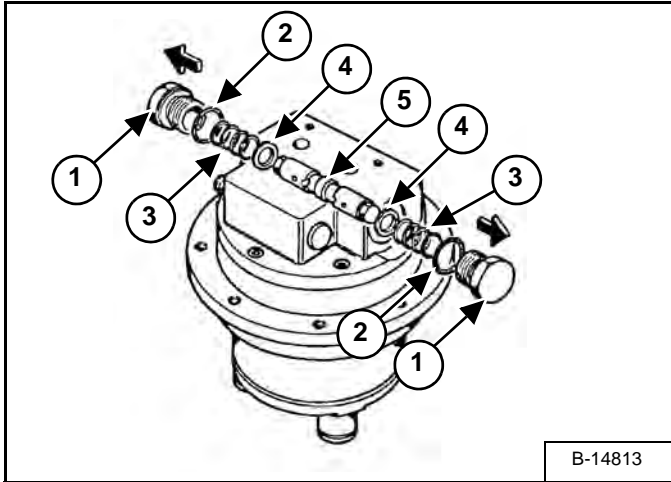

Remove the two plugs (Item 1), O-rings (Item 2), springs (Item 3) and washers (Item 4) [Figure 20-70-23].

Remove the spool (Item 5) [Figure 20-70-23].

Figure 20-70-24

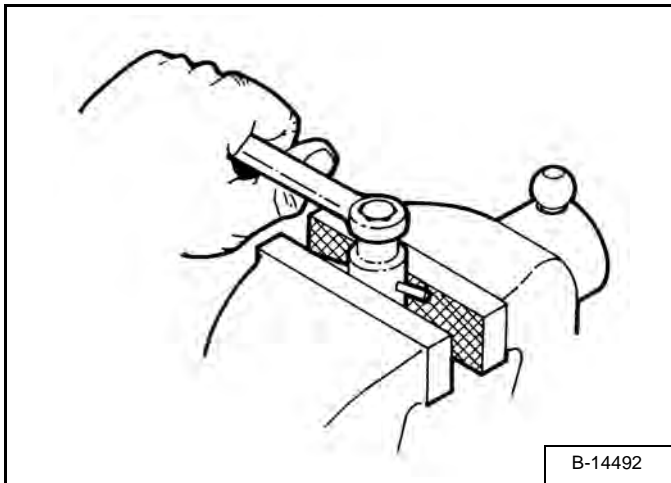

To disassemble the spool, insert a hardened pin through the hole in the spool and use a vise with protective jaws to hold the spool [Figure 20-70-24].

**NOTE: Do not use any type of tool to grip the spool or damage to the spool will result.**

Remove the plug from both ends of the spool.

Figure 20-70-25

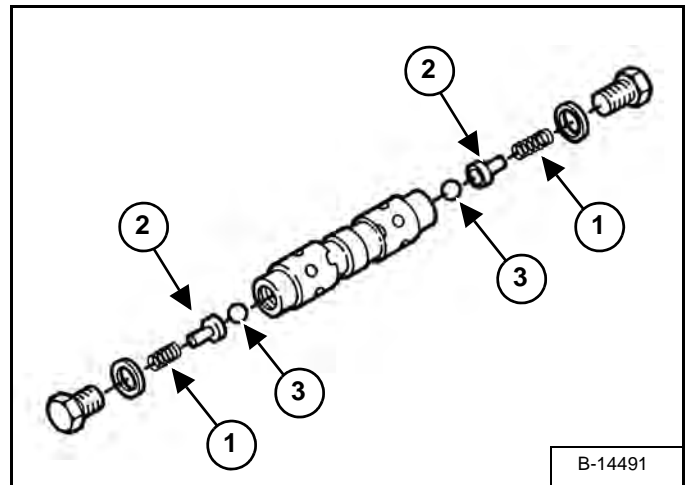

Remove the springs (Item 1), poppets (Item 2) and check balls (Item 3) [Figure 20-70-25].

Figure 20-70-26

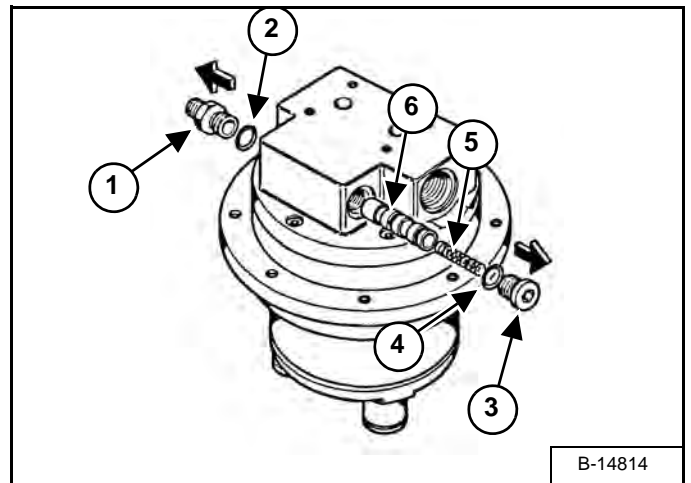

Remove the fitting (Item 1) and O-ring (Item 2). Remove the plug (Item 3), O-ring (Item 4), spring (Item 5) and two speed spool (Item 6) [Figure 20-70-26].

## TRAVEL MOTOR (CONT'D)

### Assembly (Cont'd)

To install the bearings, a bearing installation tool will be needed.

This tool is placed on the top of the bearing inner and outer race and a press is used to seat the bearings.

**Figure 20-70-59**

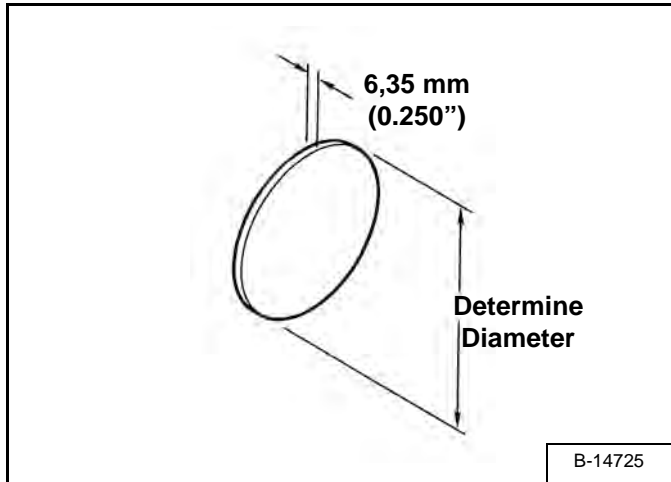

Fabricate or obtain the tool locally [Figure 20-70-59].

Select a plate that fits over the outer edges of the three pins.

**Figure 20-70-60**

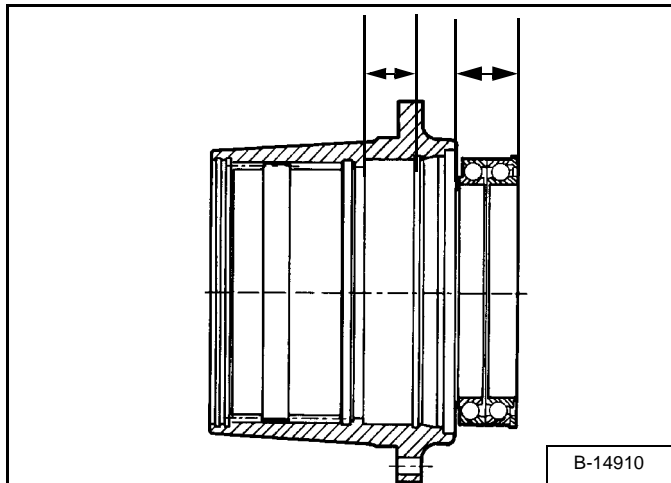

If either of the bearings or the housing has been replaced, before assembly, measure the bearing area of the hub and the two bearings. Subtract the bearing measurement from hub measurement. The difference must be between 0,0 - 0,3 mm (0.000 - 0.012 in). If the difference is greater install shims in the hub [Figure 20-70-60].

If shims are needed, order the shim kit (P/N 6671939) from Bobcat parts:

**Figure 20-70-61**

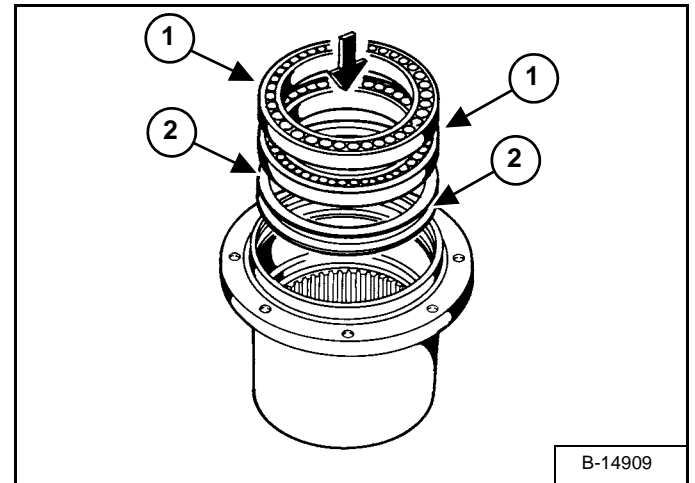

Install the two bearings (Item 1) and shims (Item 2) [Figure 20-70-61] (as required) in the housing.

**Figure 20-70-62**

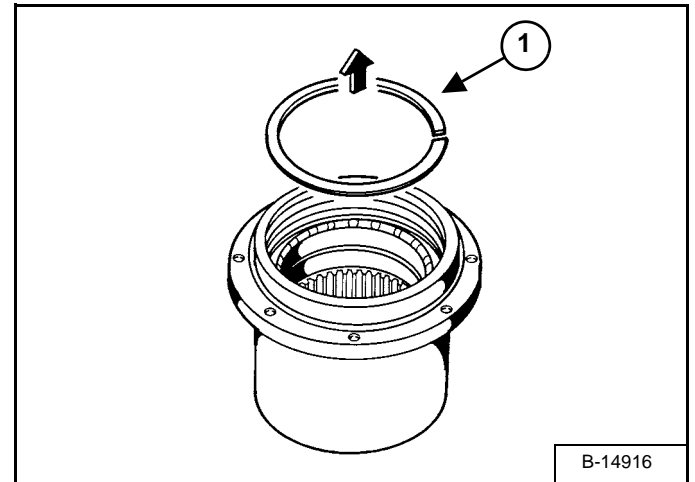

Install the snap ring (Item 1) [Figure 20-70-62] in the housing.

# TRAVEL MOTOR (CONT'D)

## Parts Identification Gear Reduction Hub

- 1. Plug
- 2. Snap Ring
- 3. Cover
- 4. O-ring
- 5. Bolt
- 6. Thrust Plate
- 7. Drive Gear
- 8. Planetary Gear
- 9. Roller Bearing
- 10. Inner Ring
- 11. Carrier
- 12. Sun Gear
- 13. Pin
- 14. Washer
- 15. Nut
- 16. Hub
- 17. Ball Bearing
- 18. Ball Steel
- 19. Seal
- 20. Spindle
- 21. Oil Seal
- 22. Drive Shaft

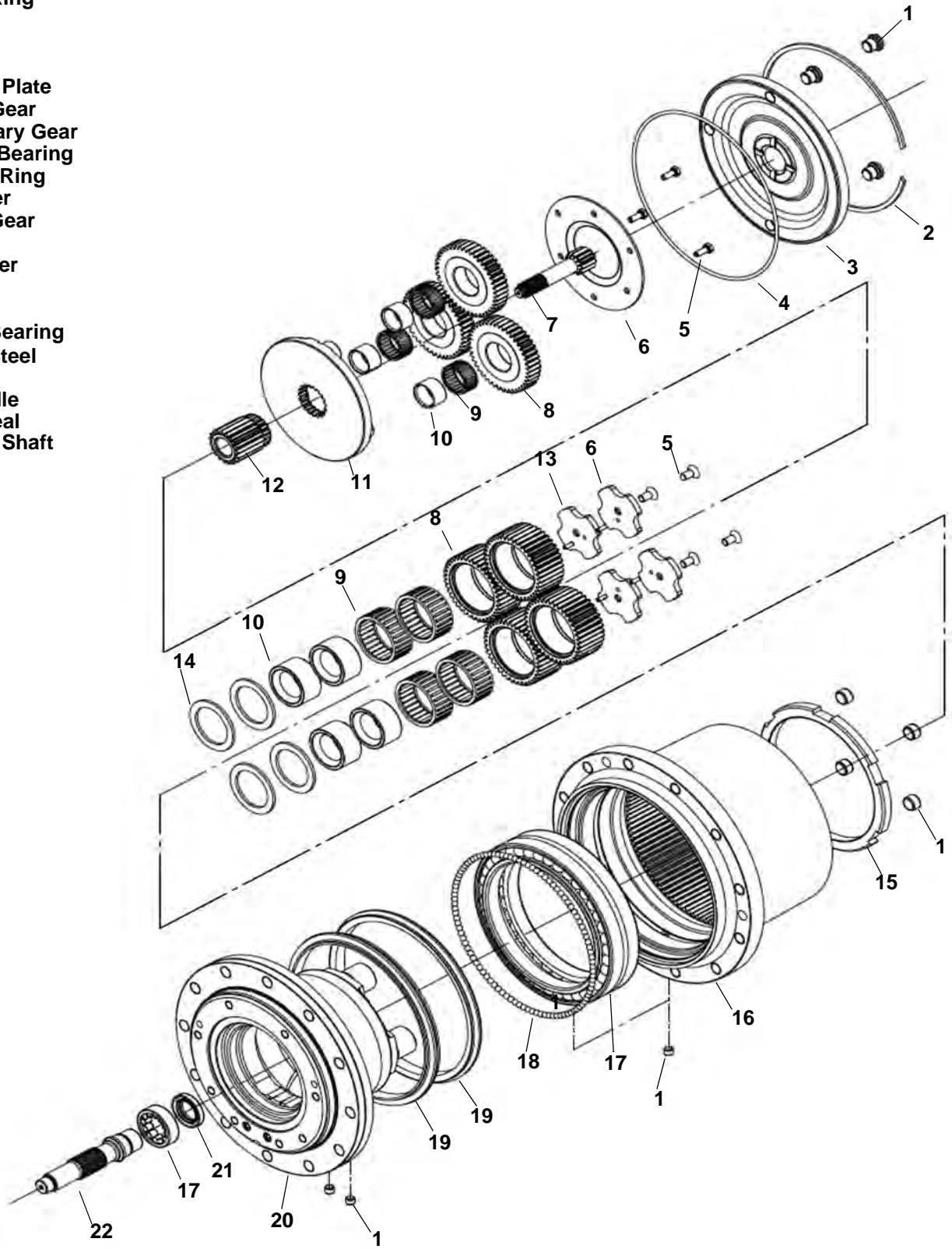

NA15489S

## TRAVEL MOTOR (CONT'D)

### Assembly (Cont'd)

Figure 20-71-37

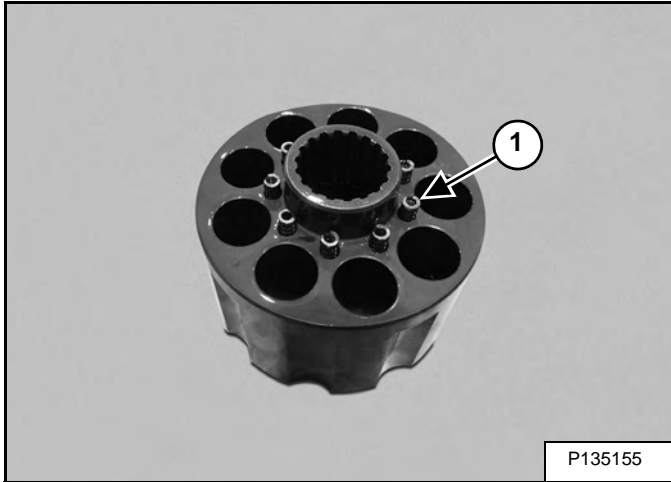

Install the springs (Item 1) [Figure 20-71-37] into the cylinder block.

Figure 20-71-38

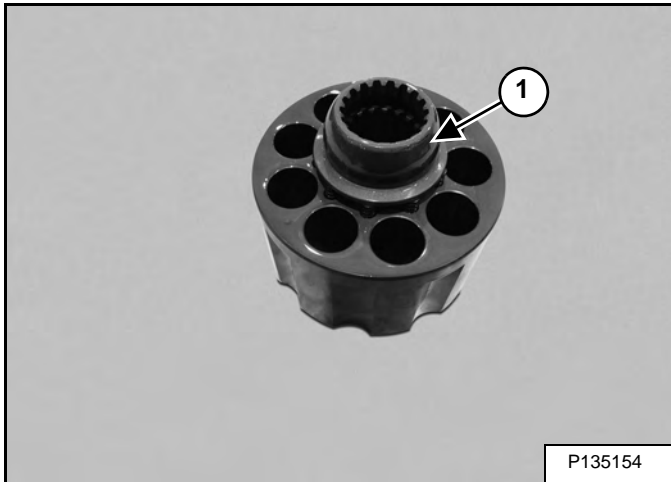

Install the thrust ball (Item 1) [Figure 20-71-38] onto the cylinder block.

Figure 20-71-39

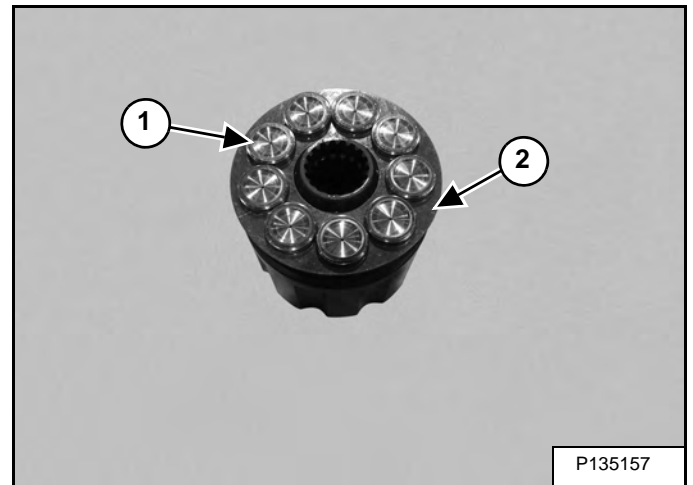

Install the piston and retainer assembly (Item 1) [Figure 20-71-39] onto the cylinder block.

Figure 20-71-40

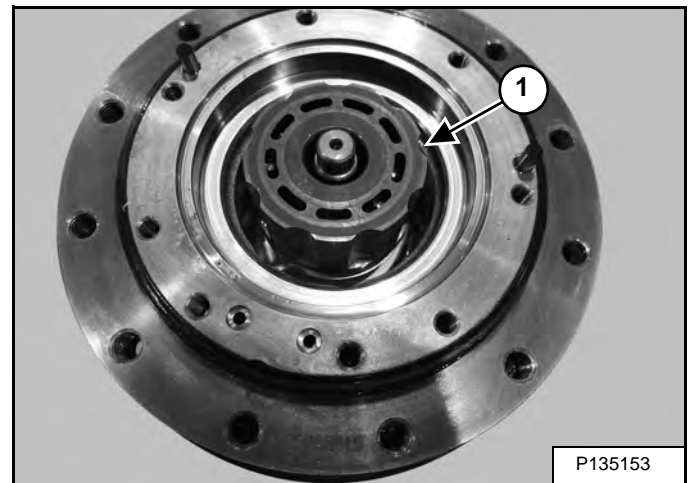

Install the cylinder block assembly (Item 1) [Figure 20-71-40] onto the shaft.

# SWIVEL JOINT (CONT'D)

## Parts Identification Straight Blade Swivel (S/N AJ1811001 - AJ1812618)

- 1. Rotor
- 2. Stop
- 3. Wear Ring
- 4. Crown Seal
- 5. Seal
- 6. Back-up Ring
- 7. Snap Ring
- 8. Housing
- 9. Plug

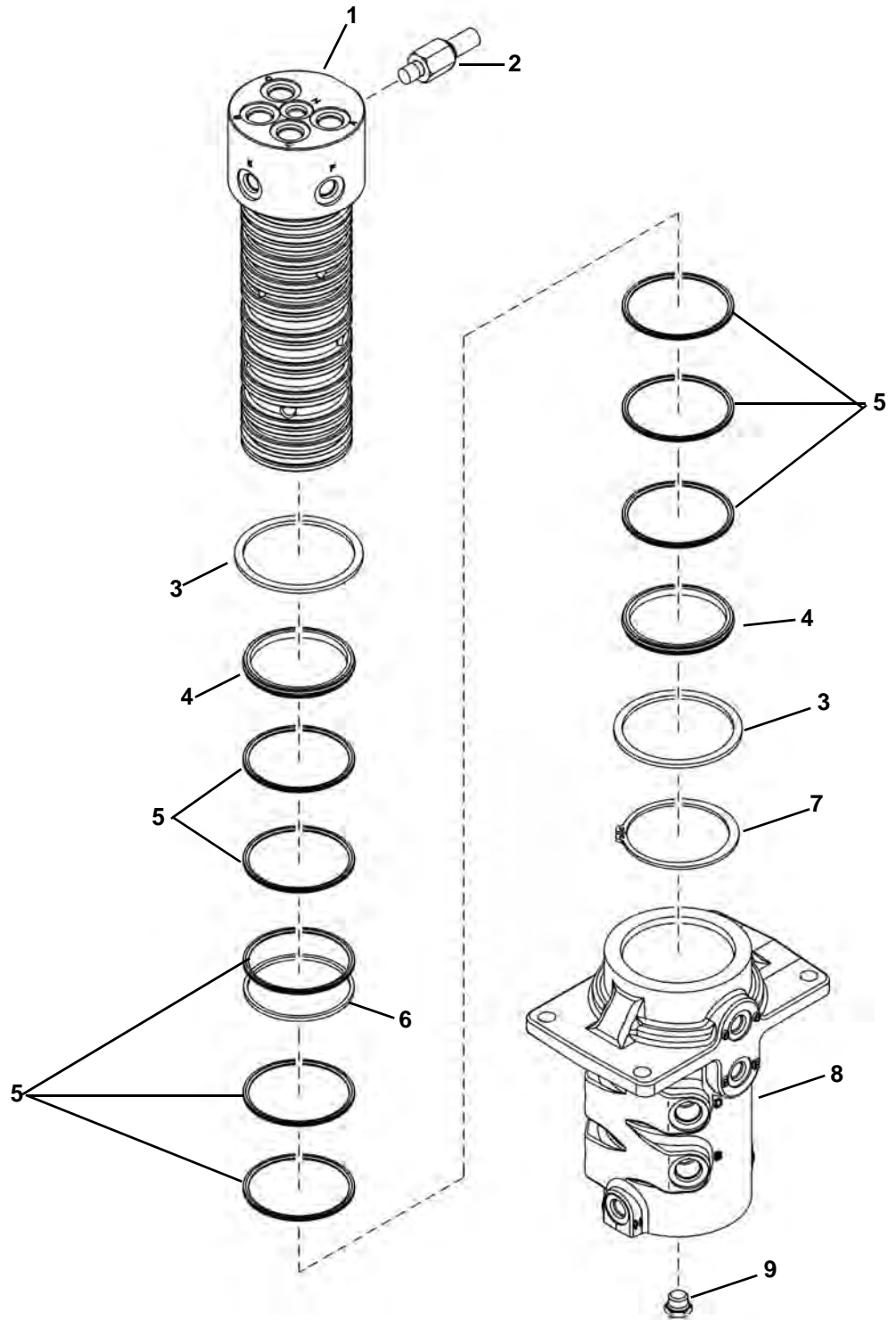

NA8466S

# SWING MOTOR (CONT'D)

## Parts Identification

- 1. Bolt
- 2. Plug
- 3. Dowel Pin
- 4. O-ring
- 5. Bearing
- 6. End Cap
- 7. Spring
- 8. Brake Piston
- 9. Friction Plate
- 10. Separation Plate
- 11. Cylinder Block
- 12. Bushing
- 13. Piston Assembly
- 14. Retainer
- 15. Thrust Plate
- 16. Poppet
- 17. Relief Valve
- 18. Housing
- 19. Snap Ring
- 20. Plunger
- 21. Spool
- 22. Valve Plate

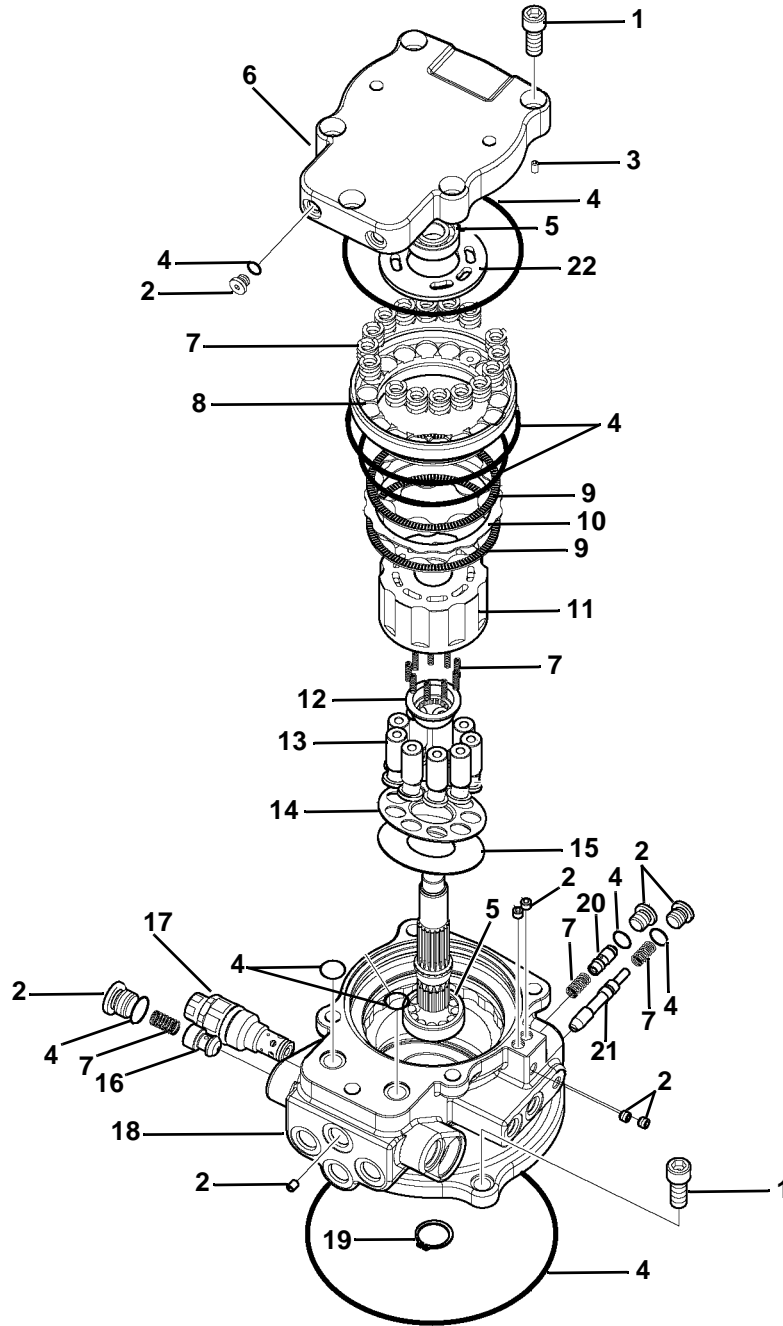

NA-1303

## SWING MOTOR (DRIVE CARRIER)

### Removal And Installation

Remove the swing motor. (See Removal And Installation on Page 20-90-1.)

**Figure 20-91-1**

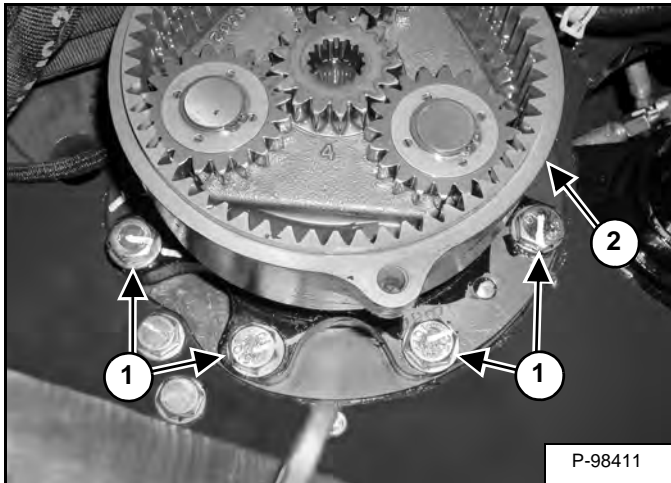

Remove the bolts (Item 1) and remove the swing motor drive carrier (Item 2) [Figure 20-91-1].

**Installation:** Tighten the bolts to 255 - 285 N•m (188 - 210 ft-lb) torque.

## CONTROL PATTERN SELECTOR VALVE (CONT'D)

### Disassembly And Assembly

Clean the outside of the valve before disassembly.

**Figure 20-100-3**

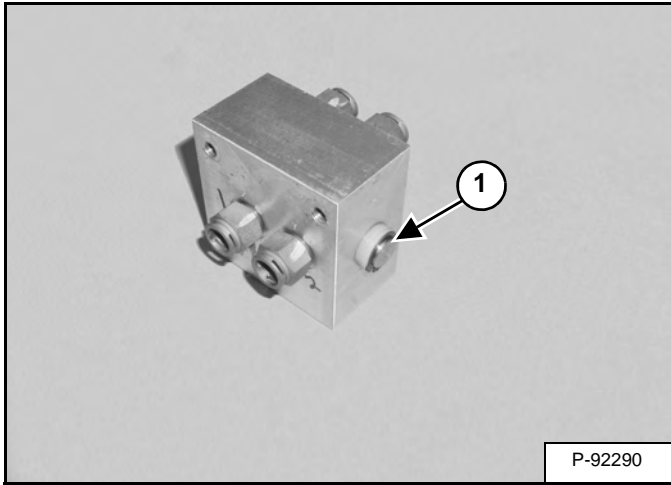

Remove the snap ring (Item 1) [Figure 20-100-3].

**Figure 20-100-4**

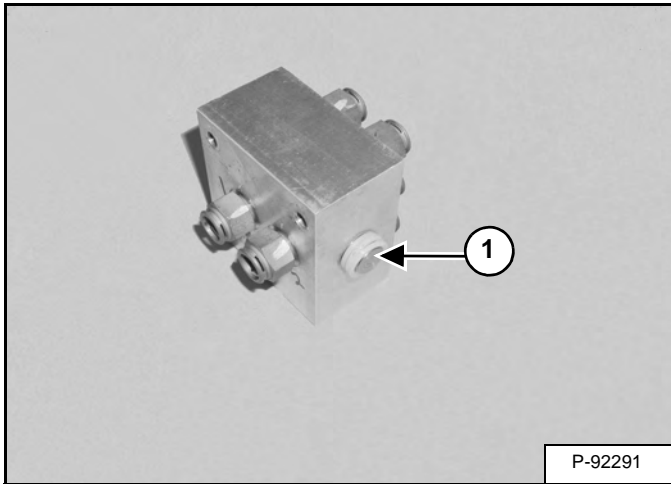

Remove the nylon washers (Item 1) [Figure 20-100-4].

**Figure 20-100-5**

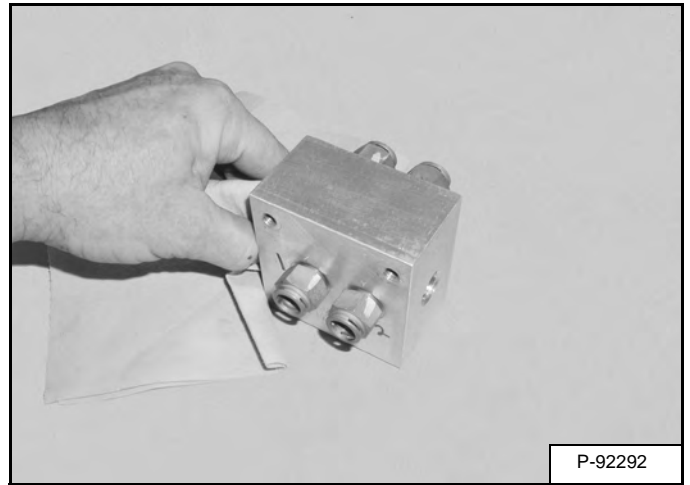

Wrap a shop towel around the spool and pull the spool out of the valve [Figure 20-100-5].

**Figure 20-100-6**

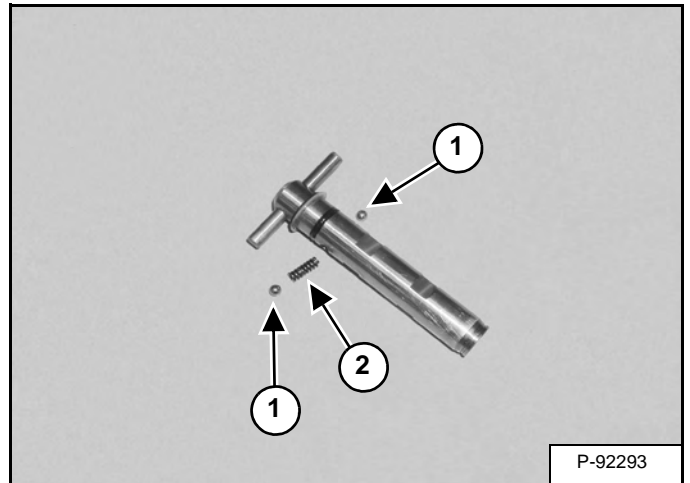

Remove the detent balls (Item 1) and spring (Item 2) [Figure 20-100-6].

## RIGHT CONTROL LEVER (JOYSTICK) (CONT'D)

### Disassembly (Cont'd)

Figure 20-110-28

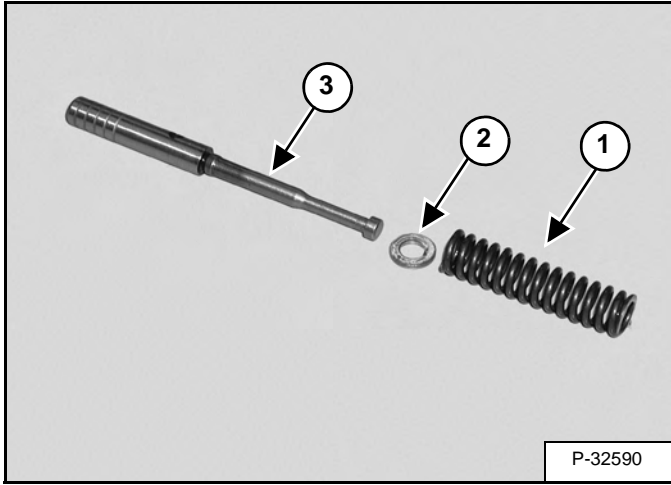

Remove the spring (Item 1) and shim (Item 2) from the spool (Item 3) [Figure 20-110-28].

Figure 20-110-29

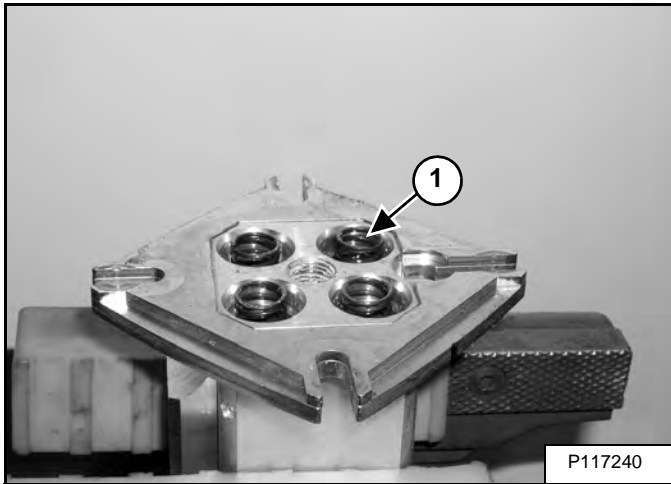

Remove the springs (Item 1) [Figure 20-110-29] from the housing.

Figure 20-110-30

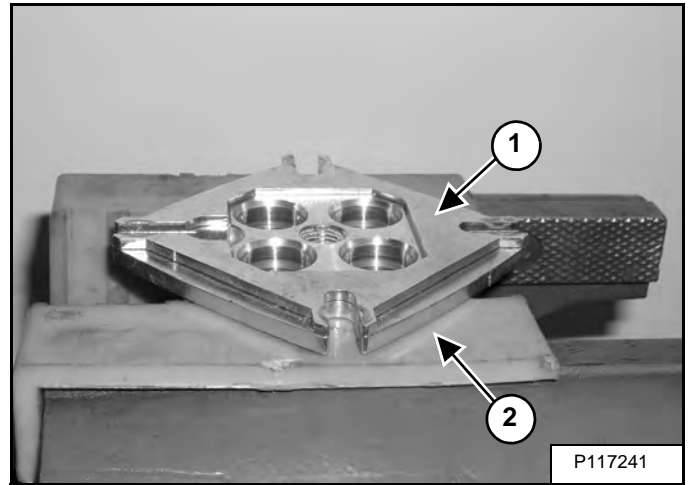

Remove both plates (Item 1 and Item 2) [Figure 20-110-30].

# LEFT CONTROL LEVER (JOYSTICK) (CONT'D)

## Parts Identification

- 1. Handle
- 2. Boot
- 3. Coupler
- 4. Control Plate
- 5. U-Joint
- 6. Grommet
- 7. Plate
- 8. Plunger
- 9. Spool
- 10. Spring
- 11. Intermediate Flange
- 12. Flange
- 13. Housing

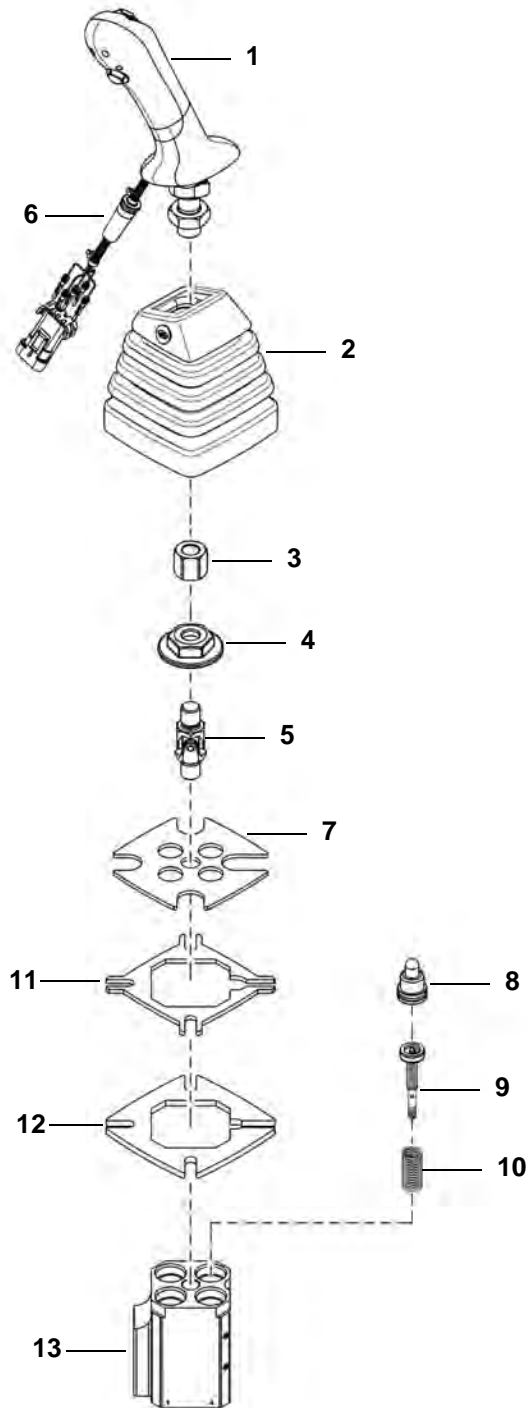

NA8316S

## HYDRAULIC FILTER MOUNT

### Removal And Installation

Drain the hydraulic reservoir. (See Removing And Replacing The Hydraulic Fluid on Page 10-130-4.)

# IMPORTANT

When repairing hydrostatic and hydraulic systems, clean the work area before disassembly and keep all parts clean. Always use caps and plugs on hoses, tubelines and ports to keep dirt out. Dirt can quickly damage the system.

I-2003-0888

Remove the right upperstructure cover. (See Removal And Installation on Page 40-80-1.)

Figure 20-130-1

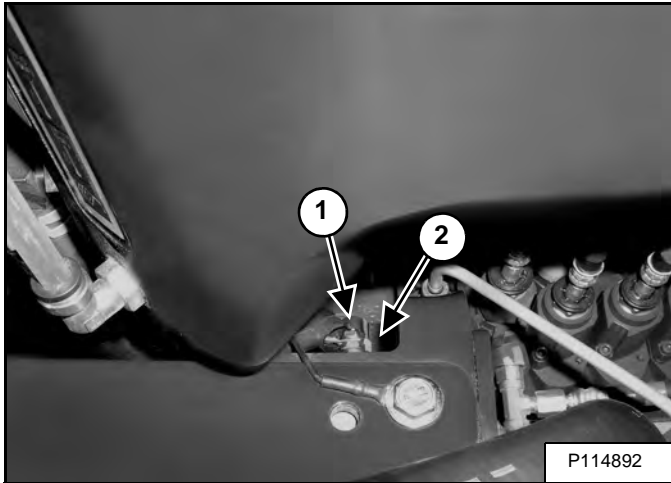

Loosen the nut (Item 1) and remove the wire harness (Item 2) [Figure 20-130-1].

Disconnect the wire harness (Item 2) [Figure 20-130-1].

Figure 20-130-2

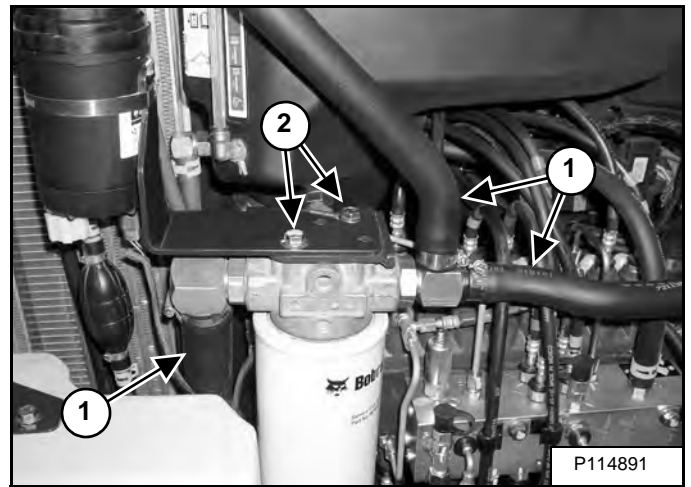

Remove the three hoses (Item 1) [Figure 20-130-2].

**Installation:** Tighten the hose clamps to 6,21 N•m (55 in-lb) torque.

Remove the two bolts (Item 2) [Figure 20-130-2] and remove the filter mount assembly.

## BLADE CONTROL LEVER (CONT'D)

### Removal And Installation

Remove the right console cover. (See Console Cover Removal And Installation on Page 40-50-1.)

Figure 20-170-9

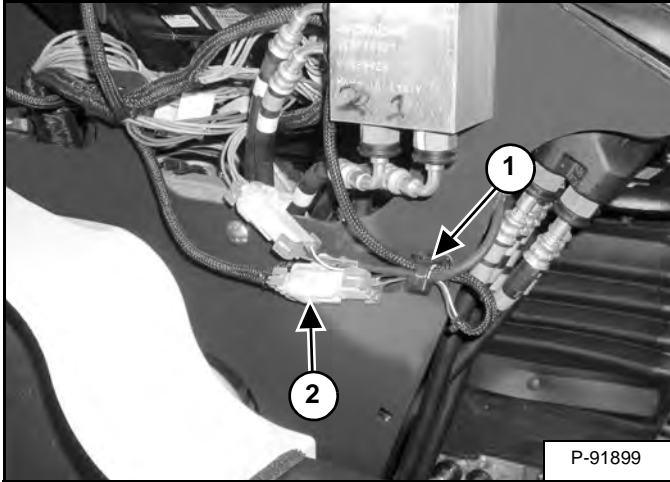

Cut and remove the cable tie (Item 1). Disconnect the wire harness (Item 2) [Figure 20-170-9].

Figure 20-170-10

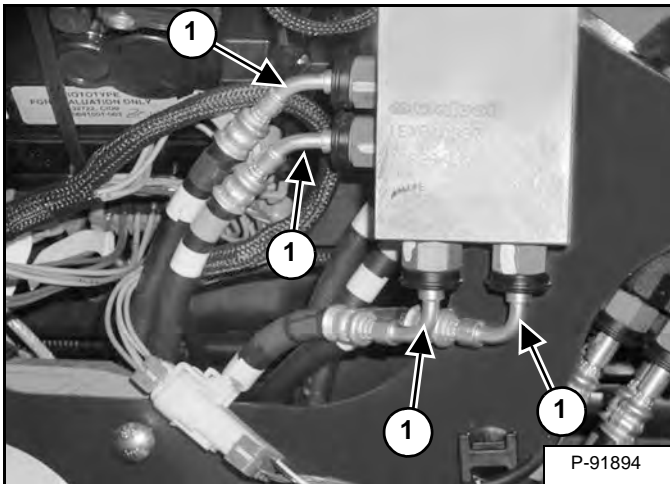

Mark and remove the four hoses (Item 1) [Figure 20-170-10].

Figure 20-170-11

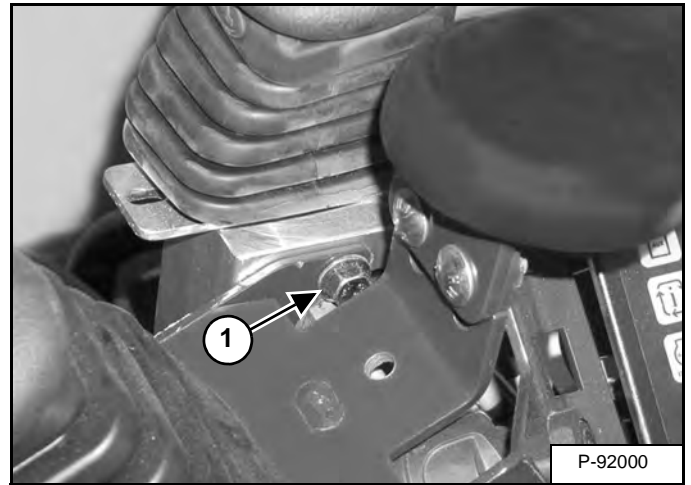
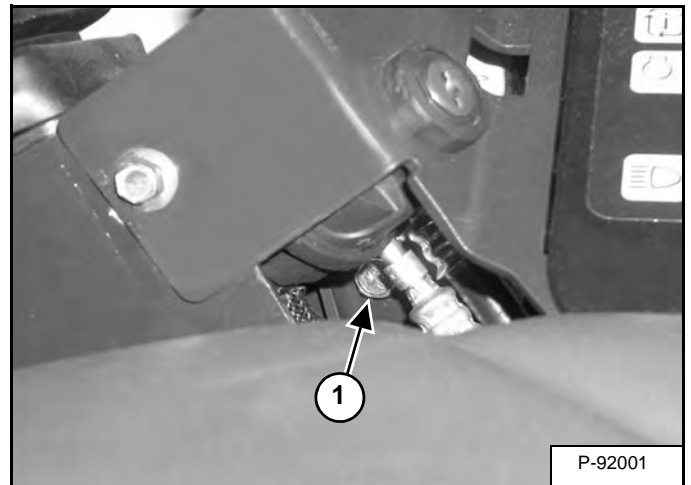

Figure 20-170-12



Remove the bolts (Item 1) [Figure 20-170-11] and [Figure 20-170-12].

## TRAVEL CONTROL VALVE

### Removal And Installation

Remove the travel levers. (See Removal And Installation on Page 40-100-1.)

Remove the floor mat and center floorplate. (See Removal And Installation on Page 40-110-1.)

Figure 20-190-1

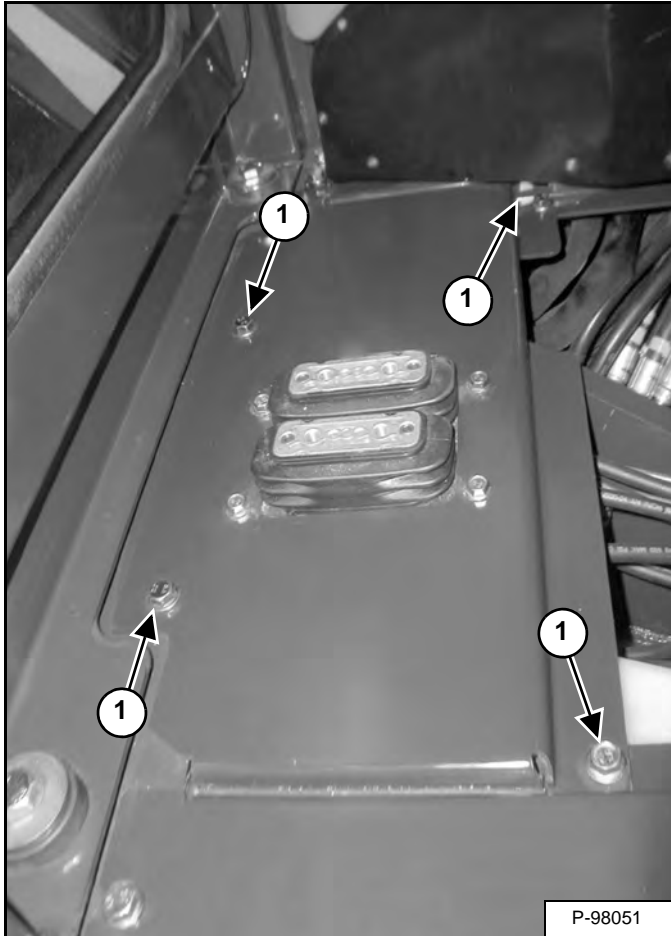

Remove the bolts (Item 1) [Figure 20-190-1] from the front floorplate.

Figure 20-190-2

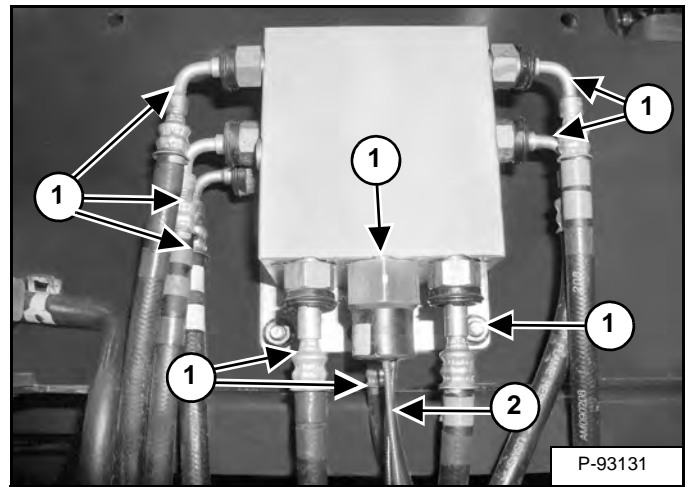

Tip the plate towards the operator's seat. Mark and remove the hoses (Item 1) [Figure 20-190-2].

If equipped with a sending unit, disconnect the wire harness (Item 2) [Figure 20-190-2].

## IMPORTANT

When repairing hydrostatic and hydraulic systems, clean the work area before disassembly and keep all parts clean. Always use caps and plugs on hoses, tubelines and ports to keep dirt out. Dirt can quickly damage the system.

I-2003-0888

Remove the valve / floorplate assembly.

## MANIFOLD (HYDRAULIC X-CHANGE) (EARLIER MODELS)

### Removal And Installation

# IMPORTANT

When repairing hydrostatic and hydraulic systems, clean the work area before disassembly and keep all parts clean. Always use caps and plugs on hoses, tubelines and ports to keep dirt out. Dirt can quickly damage the system.

I-2003-0888

Lower the work group to the ground.

With the engine off, turn the key to the ON position and move both hydraulic control levers to relieve hydraulic.

Remove the floor mat and floorplate. (See Removal And Installation on Page 40-110-1.)

Remove the tool box. (See Removal And Installation on Page 40-230-1.)

**Figure 20-210-1**

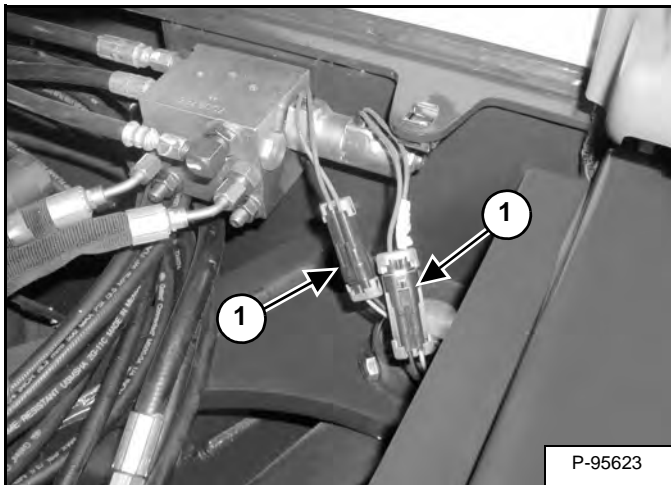

Disconnect the wire harness (Item 1) [Figure 20-210-1].

Mark all hoses for proper installation.

**Figure 20-210-2**

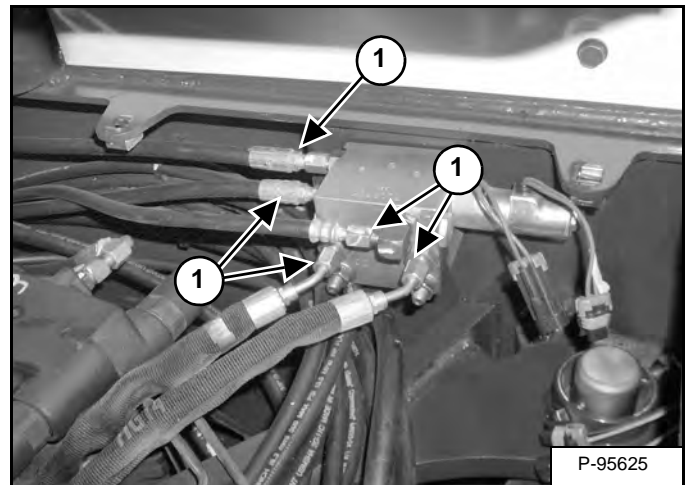

Remove the hoses (Item 1) [Figure 20-210-2].

**Figure 20-210-3**

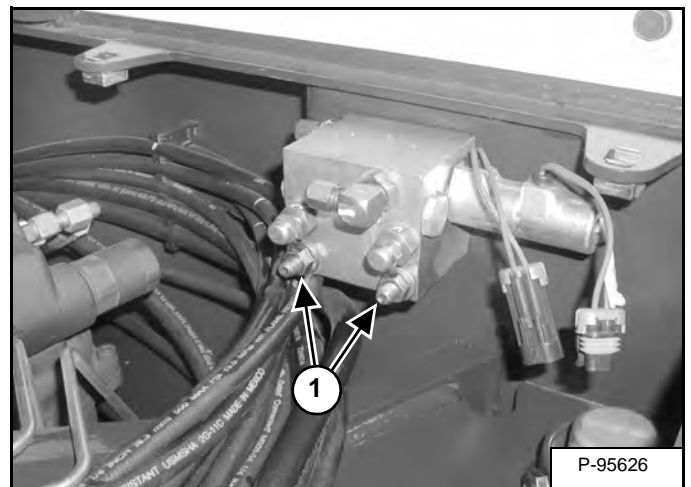

Remove the nuts (Item 1) [Figure 20-210-3]. Remove the manifold.

**MANIFOLD (HYDRAULIC X-CHANGE) (LATER MODELS) (CONT'D)**

**Disassembly And Assembly (Cont'd)**

**Figure 20-211-12**

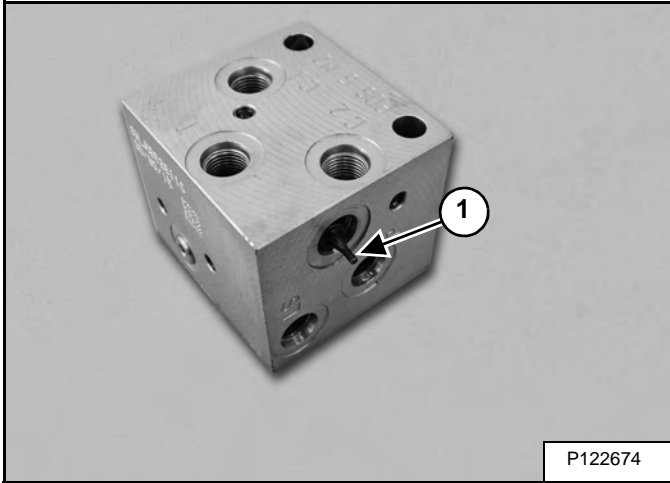

Remove the spool (Item 1) [Figure 20-211-12].

**Figure 20-211-13**

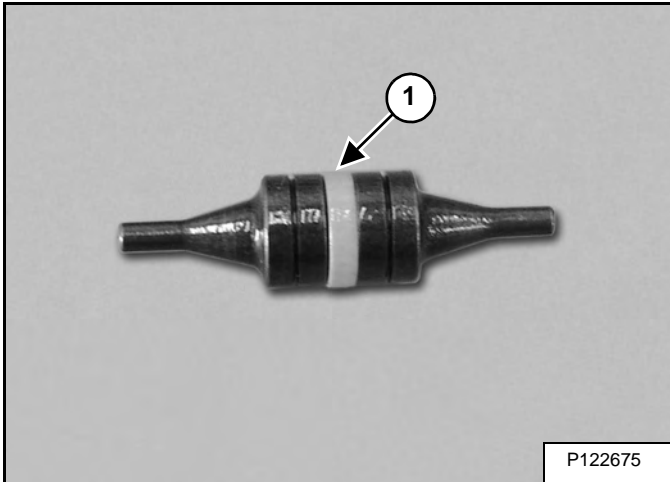

Remove the rings (Item 1) [Figure 20-211-13].

**Figure 20-211-14**

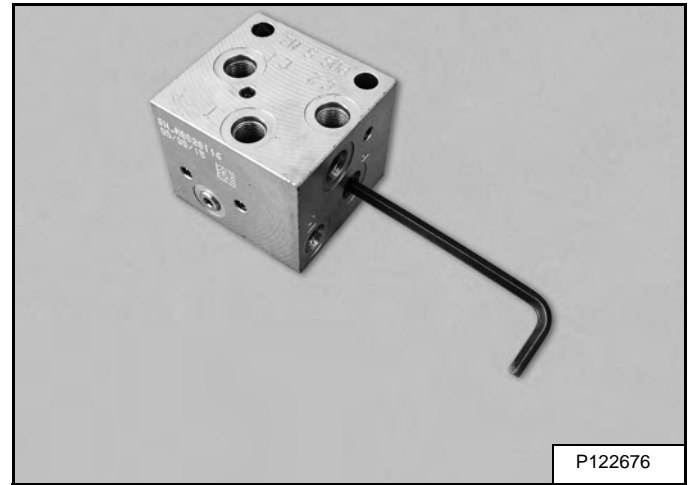

Remove the threaded in screen from the "P" port [Figure 20-211-14].

**Figure 20-211-15**

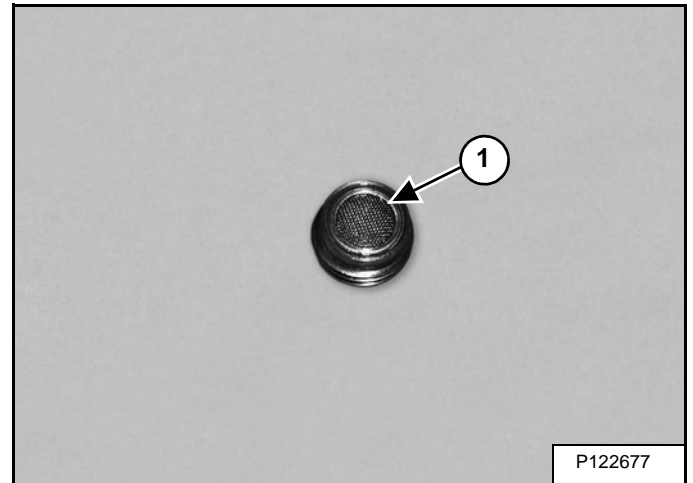

Inspect the screen (Item 1) [Figure 20-211-15] for damage.

# SECONDARY AUXILIARY VALVE (EARLIER MODELS) (CONT'D)

## Parts Identification

- 1. Nut
- 2. Coil
- 3. Solenoid
- 4. O-ring
- 5. Back-up Ring
- 6. Relief Valve
- 7. Plug
- 8. Spring
- 9. Body
- 10. Spool
- 11. Check Valve

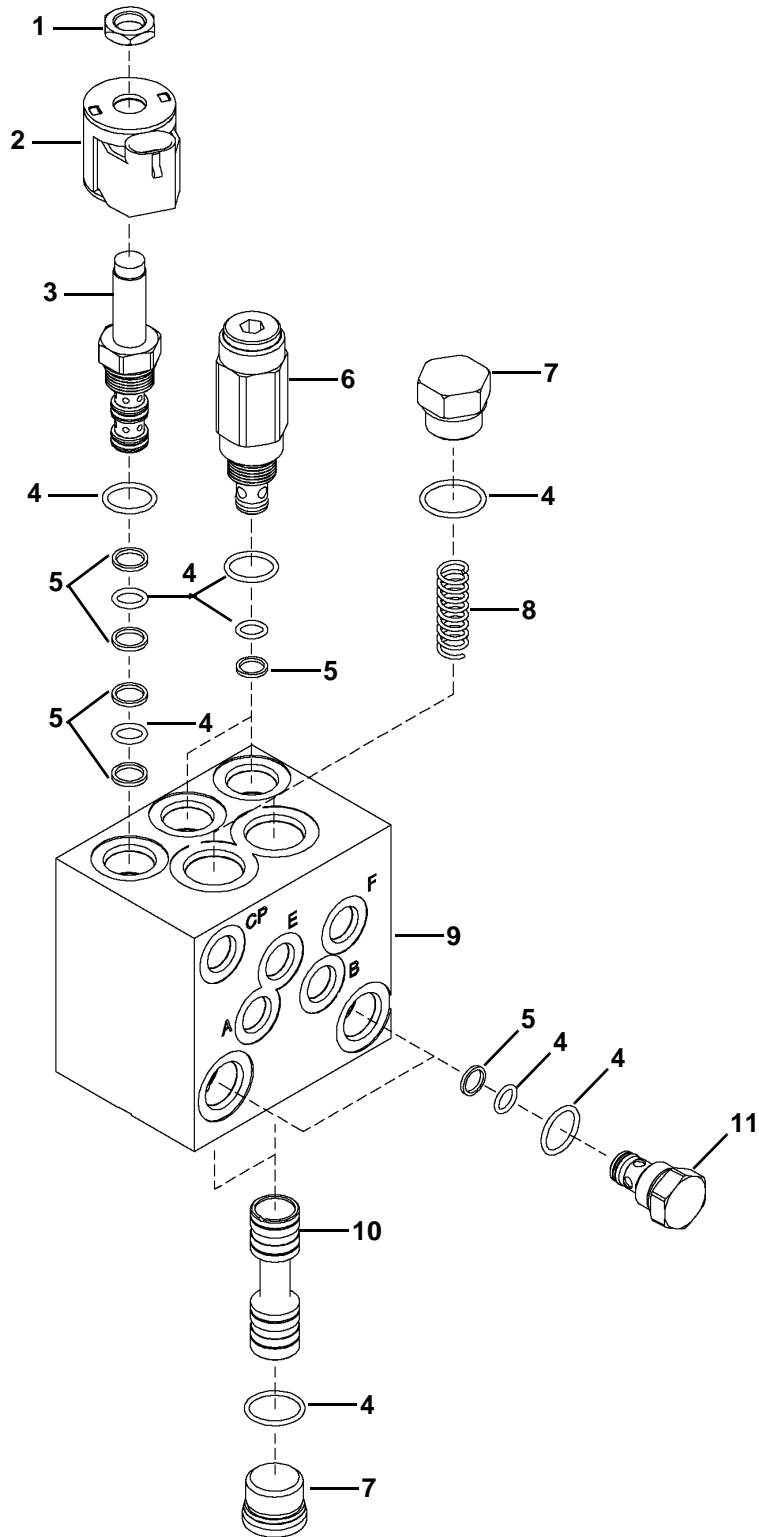

NA2303S

**SECONDARY AUXILIARY VALVE (LATER MODELS)  
(CONT'D)**

**Disassembly And Assembly (Cont'd)**

**Figure 20-221-10**

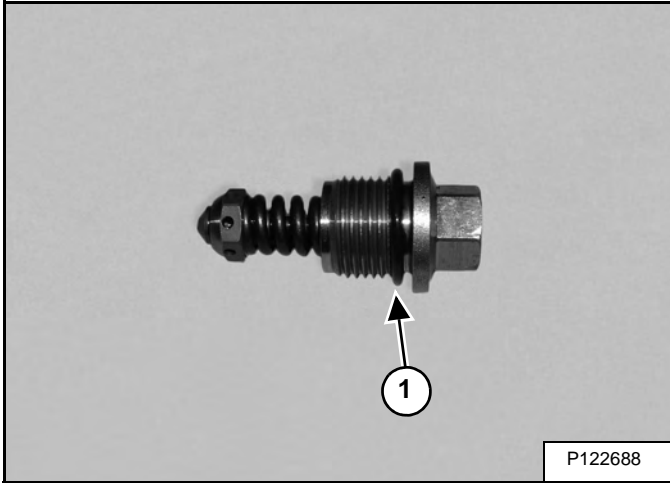

Remove the O-ring (Item 1) [Figure 20-221-10].

**Figure 20-221-11**

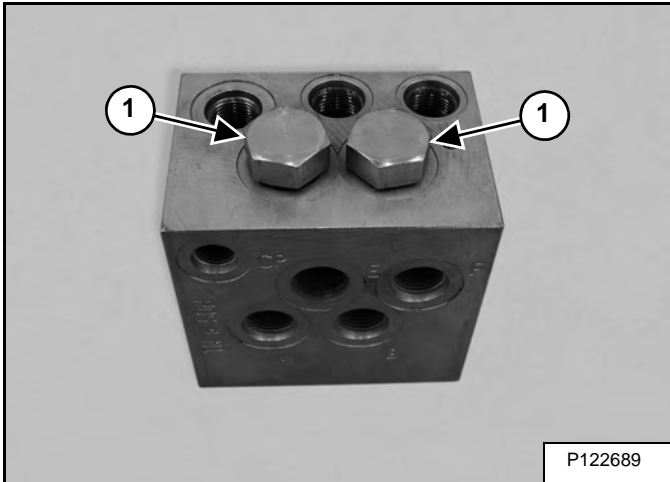

Remove the plugs (Item 1) [Figure 20-221-11].

**Figure 20-221-12**

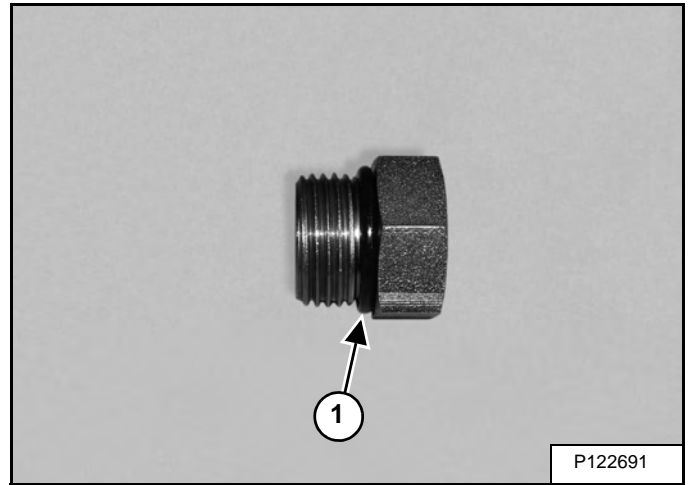

Remove the O-ring (Item 1) [Figure 20-221-12].

**Figure 20-221-13**

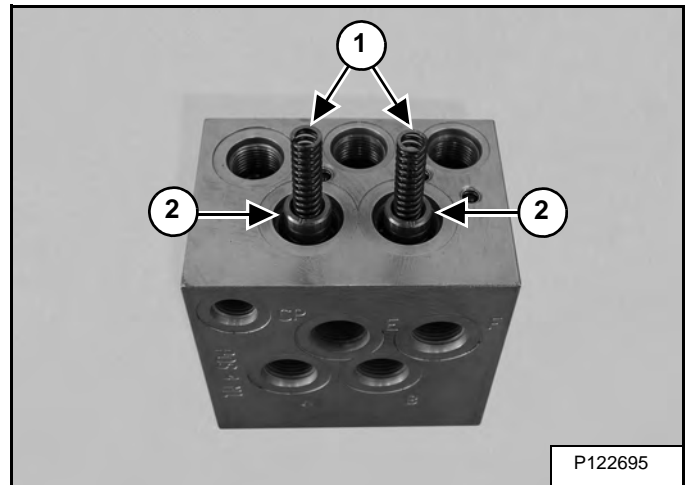

Remove the springs (Item 1) and spools (Item 2) [Figure 20-221-13].

## BLADE (ANGLE)

### Removal And Installation

Figure 30-11-1

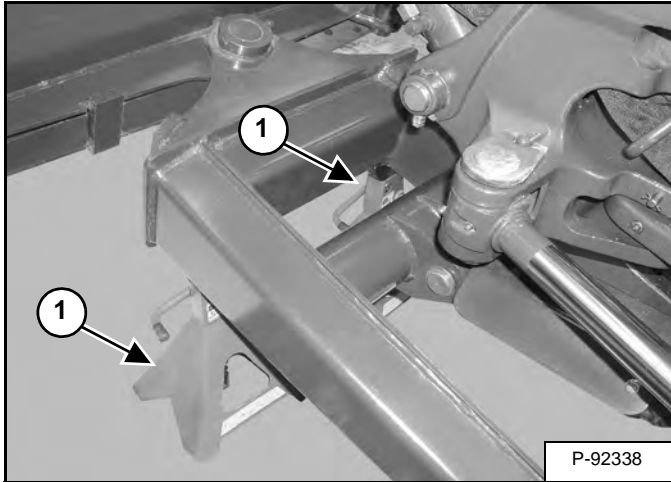

Raise the blade fully and install jackstands (Item 1) [Figure 30-11-1] under the blade arms.

Figure 30-11-2

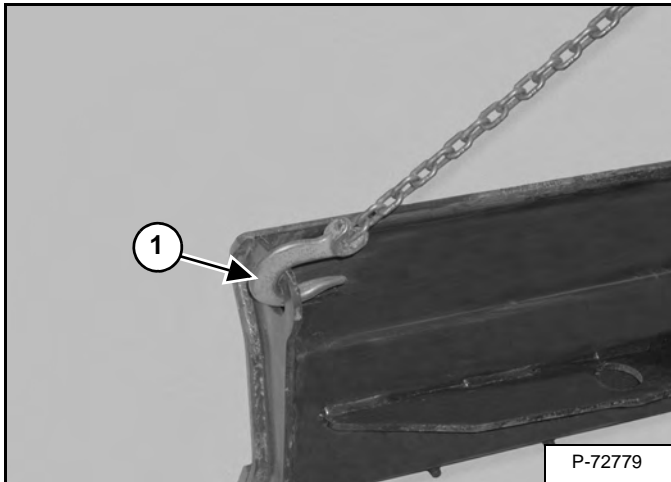

Attach a chain (Item 1) [Figure 30-11-2] and hoist to both ends of the blade.

Apply slight upward pressure on the blade.

Figure 30-11-3

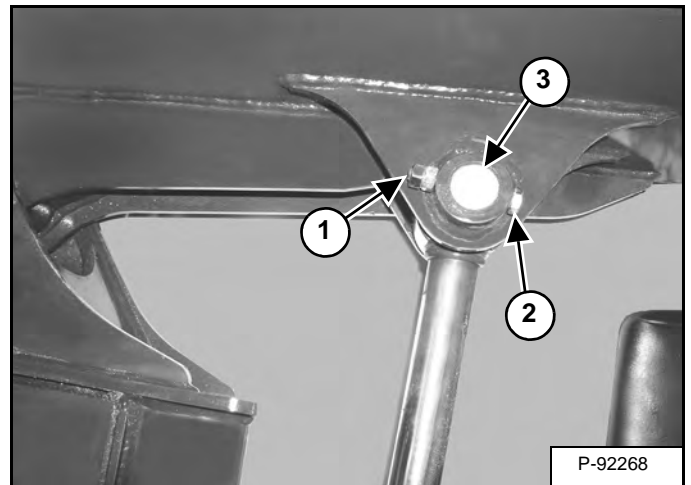

Remove the nuts (Item 1), bolt (Item 2) and pin (Item 3) [Figure 30-11-3] from the rod end of the angle blade cylinder.

Figure 30-11-4

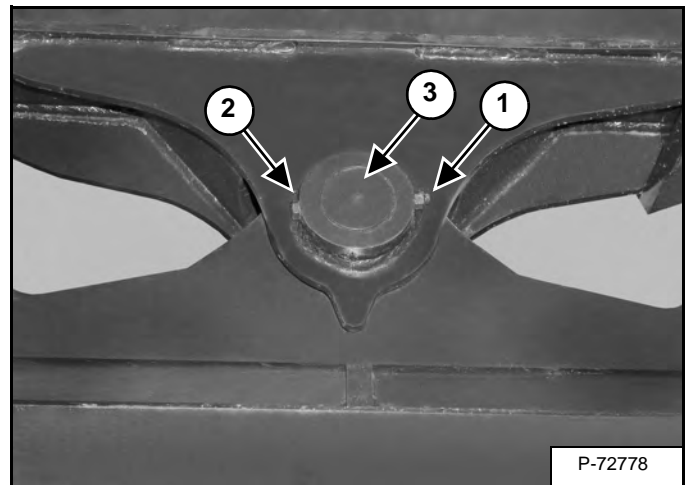

Remove the nut (Item 1), bolt (Item 2) and pin (Item 3) [Figure 30-11-4].

Remove the angle blade.

## TRACK UNDERCARRIAGE COMPONENTS (RUBBER TRACK) (CONT'D)

### Idler Disassembly (Cont'd)

Figure 30-20-20

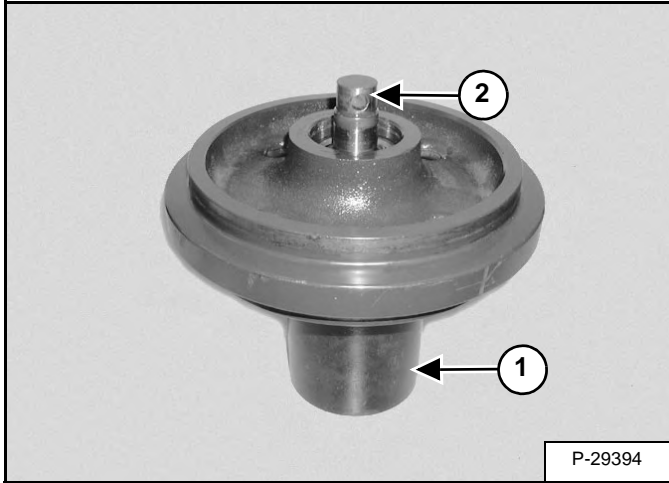

Place the idler on the support fixture (Item 1) [Figure 30-20-20].

Using a soft faced hammer, tap the shaft (Item 2) [Figure 30-20-20] and bearing out the bottom of the idler.

Figure 30-20-21

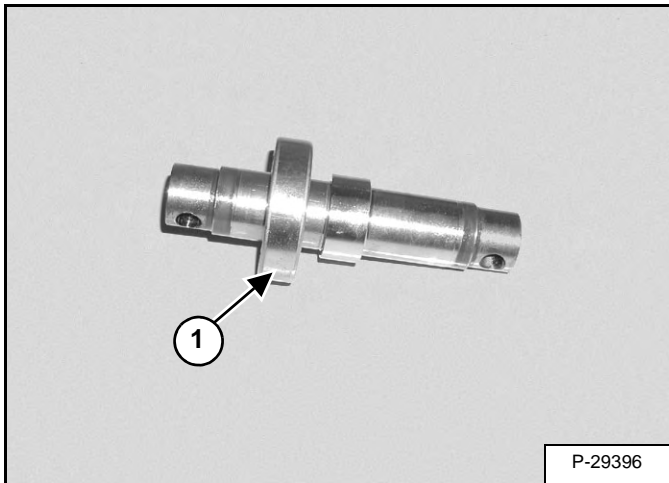

Slide the bearing (Item 1) [Figure 30-20-21] off the shaft.

Figure 30-20-22

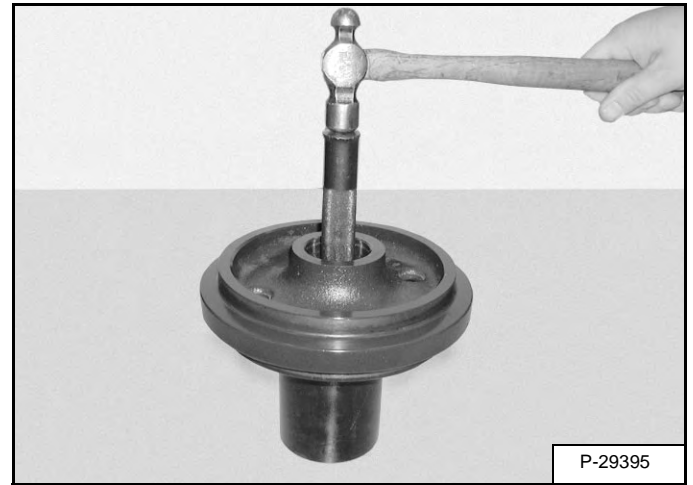

Turn the idler over, and using a bearing driver, remove the second bearing [Figure 30-20-22].

CLICK HERE TO **DOWNLOAD** THE COMPLETE MANUAL

- Thank you very much for reading the preview of the manual.
- You can download the complete manual from: [www.heydownloads.com](http://www.heydownloads.com) by clicking the link below



- Please note: If there is no response to CLICKING the link, please download this PDF first and then click on it.

CLICK HERE TO **DOWNLOAD** THE COMPLETE MANUAL

## **TRACK UNDERCARRIAGE COMPONENTS (STEEL TRACK)**

### **Description**

The track undercarriage components consist of the front idler, top roller, bottom rollers, drive motor and track frame.

# TRACK UNDERCARRIAGE COMPONENTS (STEEL TRACK) (CONT'D)

## Idler Parts Identification

- 1. Roll Pin
- 2. Block
- 3. Seal
- 4. Snap Ring
- 5. Bearing
- 6. Shaft
- 7. Idler

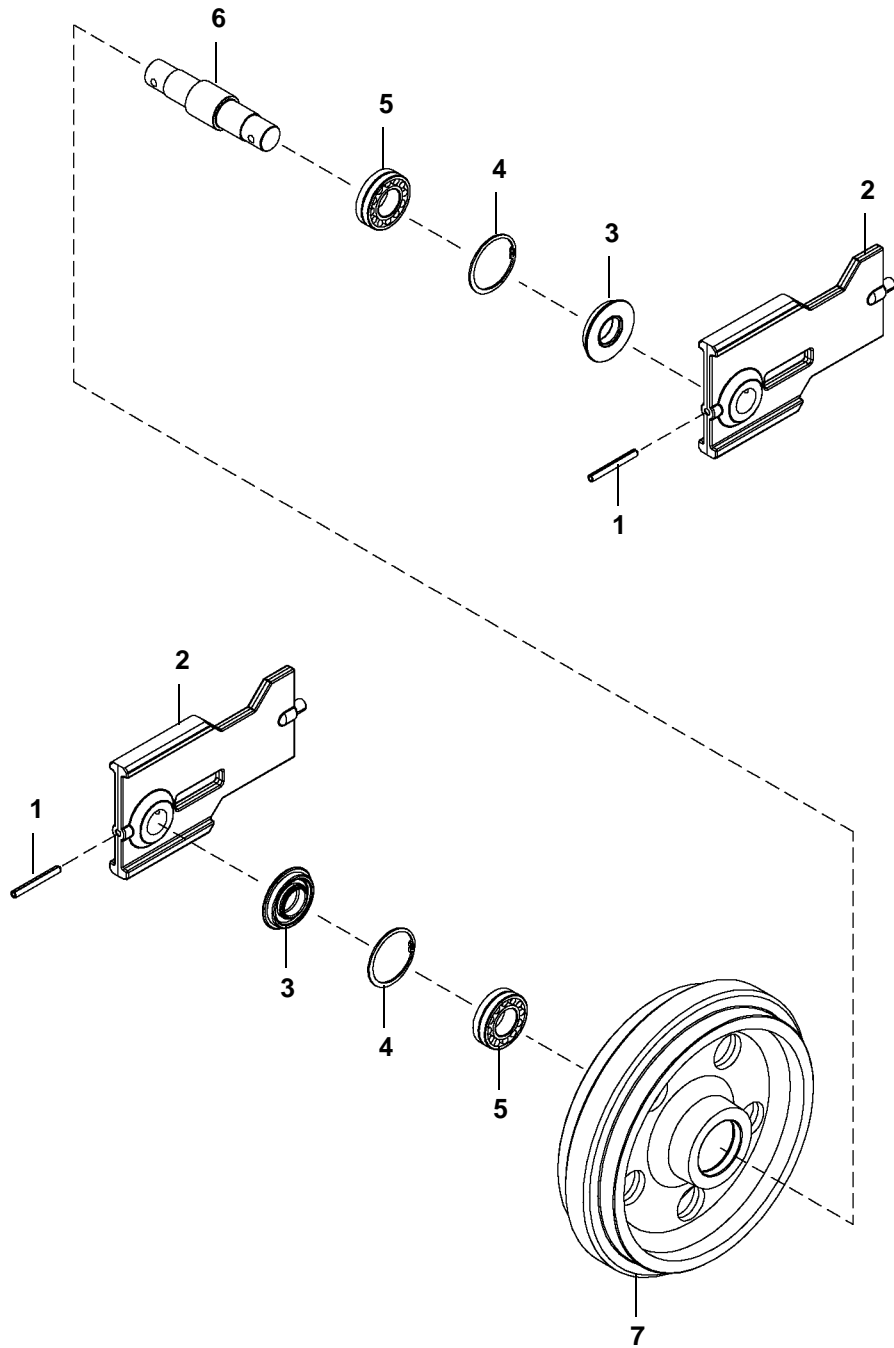

PE1911S

## TRACK UNDERCARRIAGE COMPONENTS (STEEL TRACK) (CONT'D)

### Roller Removal And Installation

Figure 30-21-44

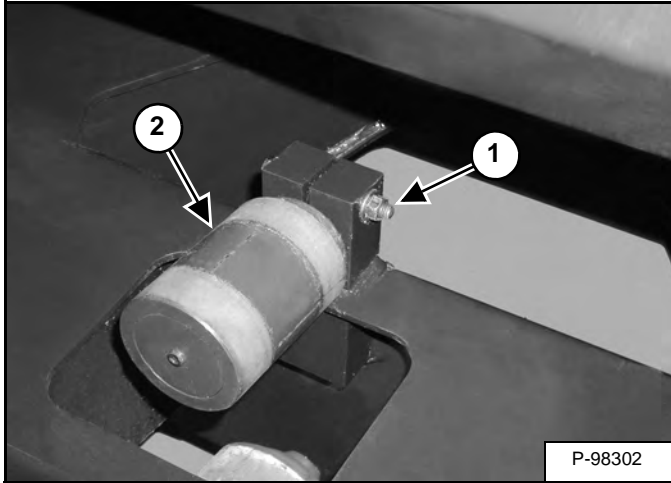

Loosen the bolt (Item 1) and nut. Remove the top roller (Item 2) [Figure 30-21-44].

Figure 30-21-45

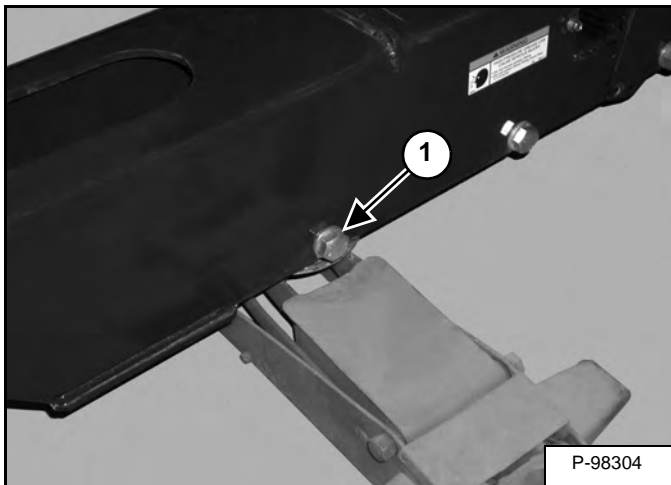

Loosen the bolts (Item 1) [Figure 30-21-45] on the track roller on both sides of the track frame.

**Installation:** Tighten the bolts to 640 - 700 N•m (470 - 520 ft-lb) torque.

Figure 30-21-46

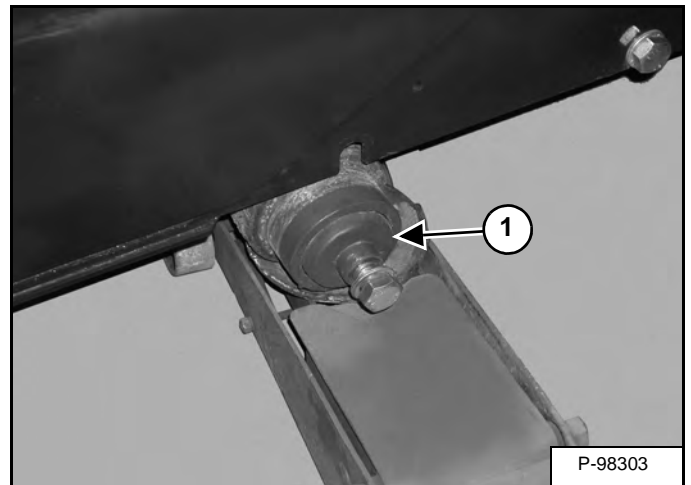

Remove the bottom roller (Item 1) [Figure 30-21-46].

**NOTE:** The top and bottom rollers are not serviceable. Replace the roller if it is damaged.

## TRACK MAINTENANCE (CONT'D)

### Track Damage Identification (Cont'd)

#### Cracks And Cuts On The Lug Side Rubber

Figure 30-30-18

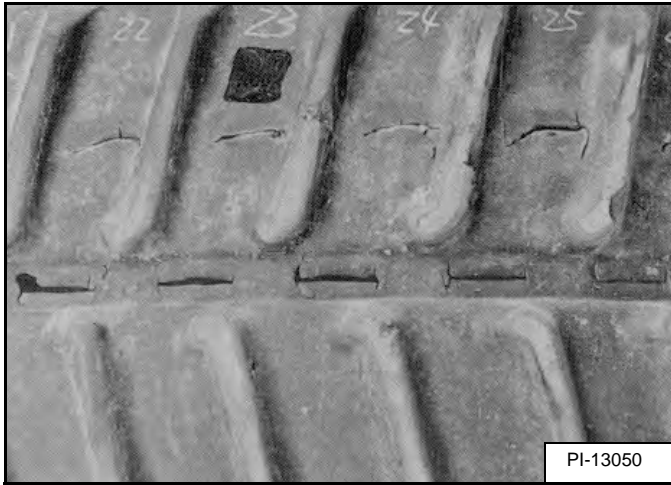

#### **Damage:**

Sometimes cracks and cuts on the lug side rubber at the edges of the embedded metals can be observed [Figure 30-30-18].

#### **Replacement:**

No replacement is required unless the cuts on the lug side rubber are discovered all around the edges of the embedded metals, as this will result in a complete cut off.

Figure 30-30-19

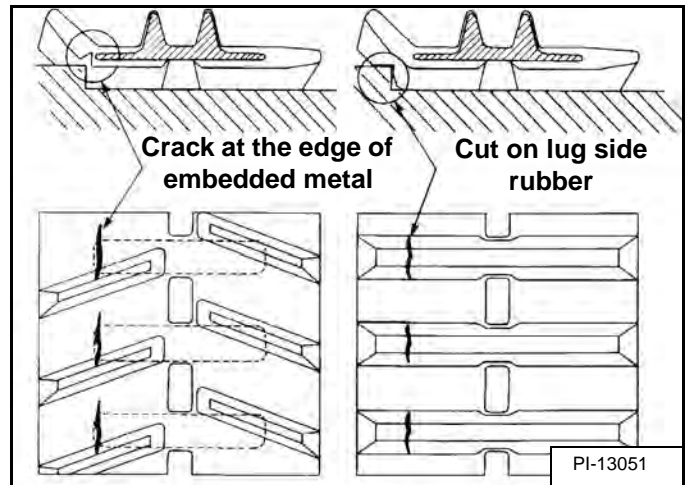

#### **Causes of the damage:**

When rubber tracks drive over sharp projections, intensive stress is applied to the lug side rubber surface, especially at the edges of embedded metals, causing cracks and cuts in the area around the embedded metals [Figure 30-30-19].

#### **Prevention:**

To avoid extensive stress applied to the lug root where metals are embedded, machine operators are requested to avoid driving over stumps and ridges.



**Bobcat**®

# CAB

## Removal And Installation

Build the service lifting bracket used to remove and install the cab. Use the dimensions shown [Figure 40-30-1] to build the service lifting bracket.

Figure 40-30-1

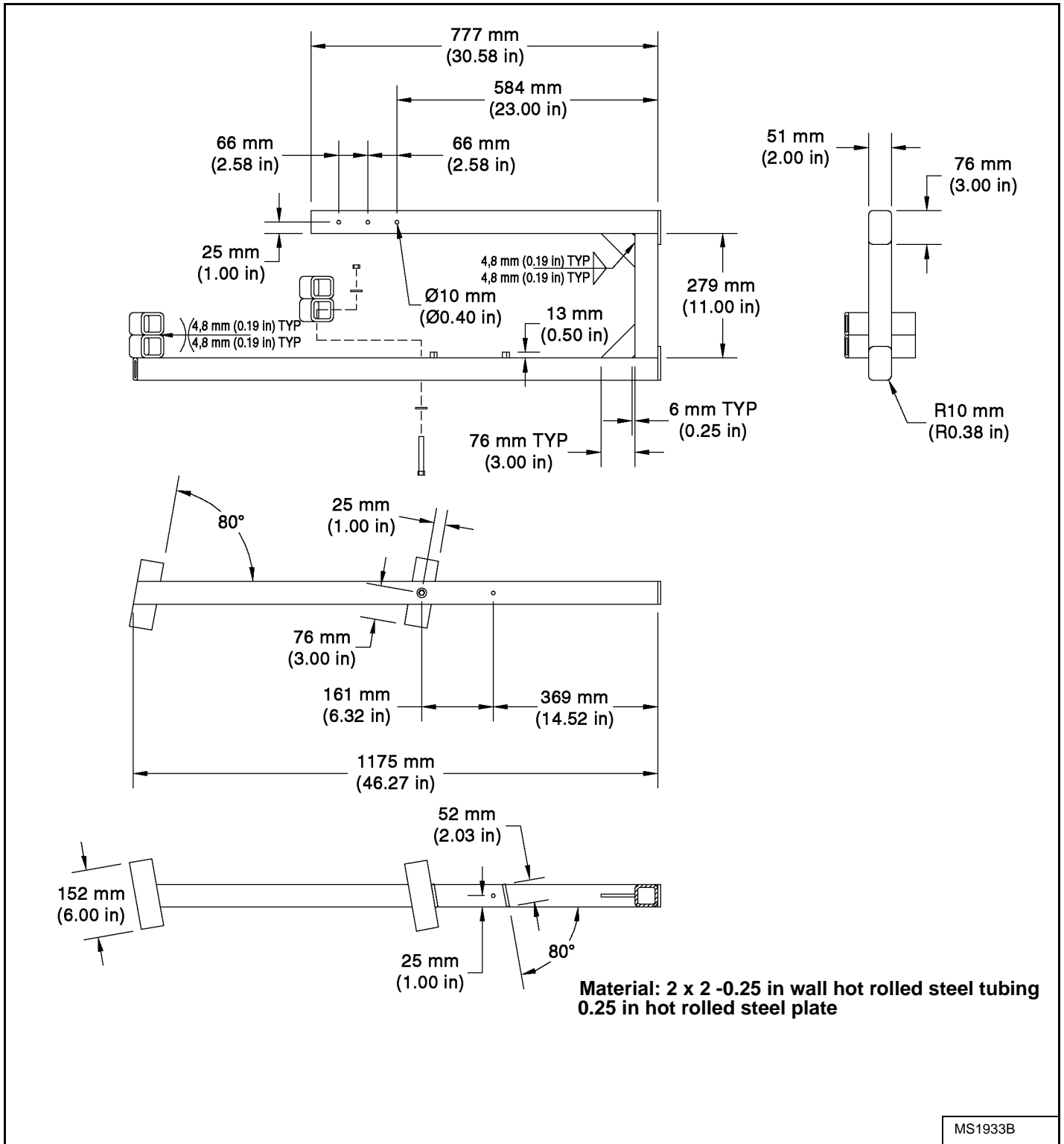

MS1933B

## CAB (CONT'D)

### Right Side Front And Rear Sliding Window Weather Strip Removal And Installation

Remove the window.

**Figure 40-30-28**

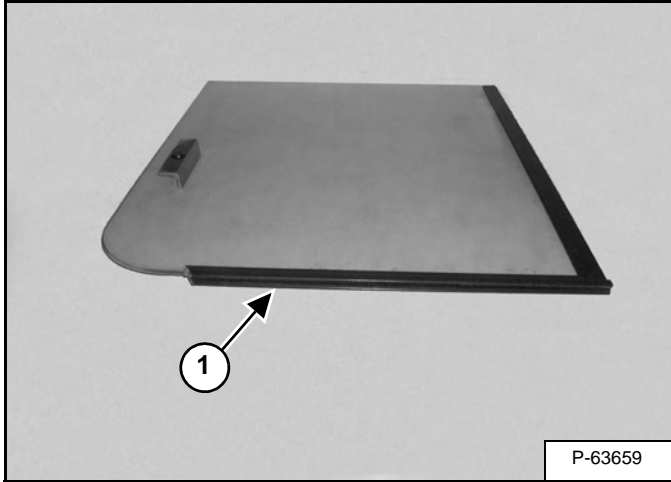

Remove the weather strip (Item 1) [Figure 40-30-28] from the bottom channel of the window.

**Installation:** Clean the bottom channel. Apply a bead of adhesive in the channel.

**Figure 40-30-29**

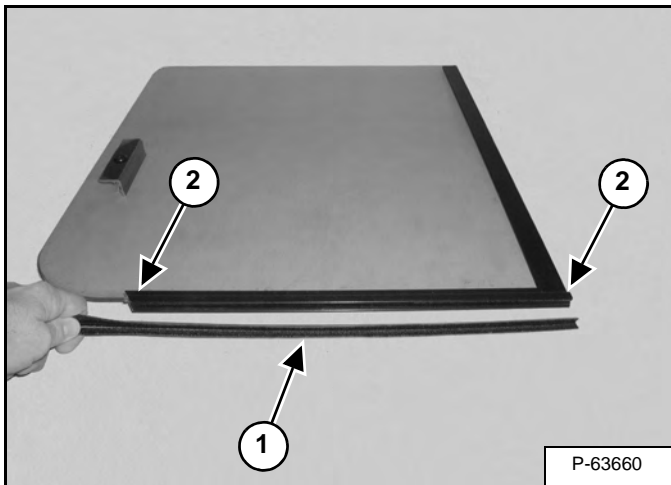

Install the new weather strip (Item 1). Cut the weather strip flush with the ends of the window channel (Item 2) [Figure 40-30-29].

### Right Side Front And Rear Sliding Window Wiper Strip Removal And Installation

Remove the window.

**Figure 40-30-30**

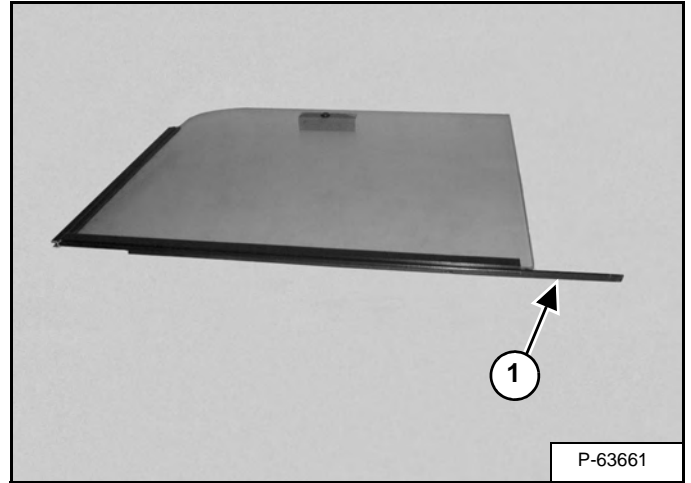

Remove the wiper strip (Item 1) [Figure 40-30-30] from the window channel.

# SEAT

## Removal And Installation

Figure 40-40-1

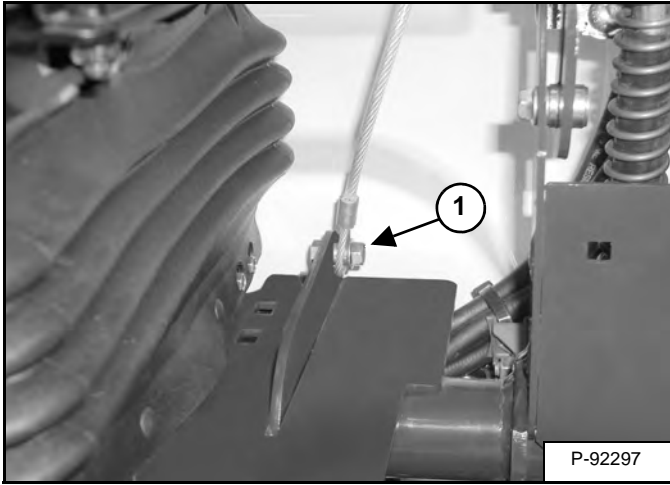
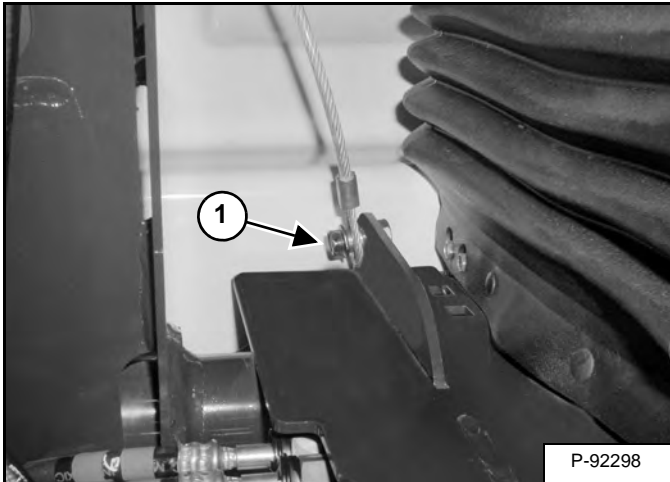

Figure 40-40-2



Remove the nuts (Item 1) [Figure 40-40-1] and [Figure 40-40-2] and bolts from the cables.

Figure 40-40-3

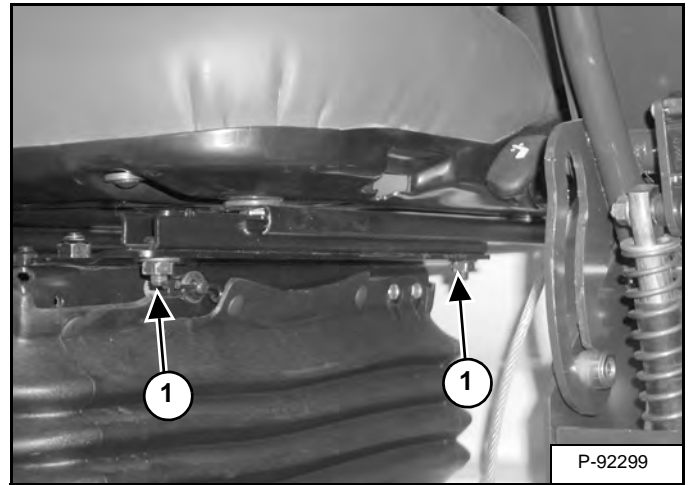
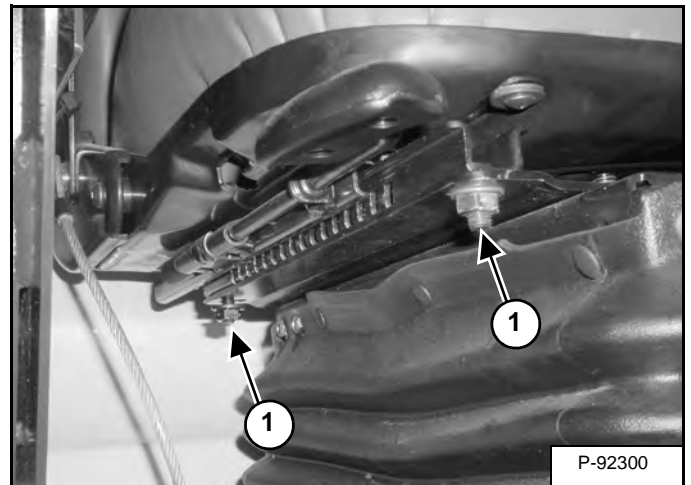

Figure 40-40-4



Remove the nuts (Item 1) [Figure 40-40-3] and [Figure 40-40-4] from the seat rails.

Remove the seat.

## LEFT CONSOLE (CONT'D)

### Compression Spring Removal And Installation (Cont'd)

Figure 40-60-15

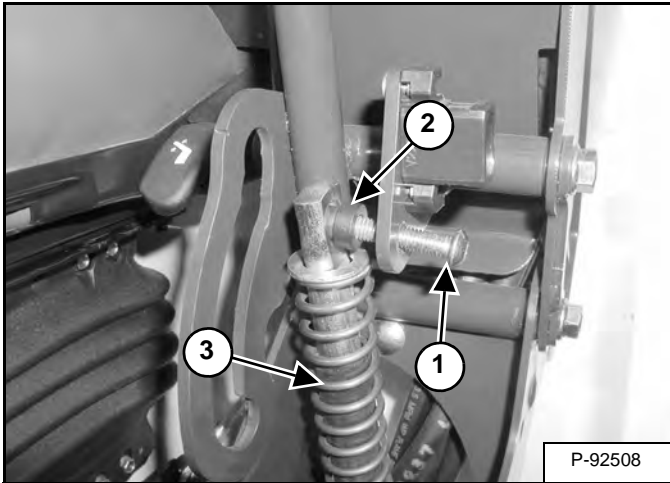

Remove the bolt (Item 1) and bushing (Item 2). Remove the spring assembly (Item 3) [Figure 40-60-15] from the console.

Figure 40-60-16

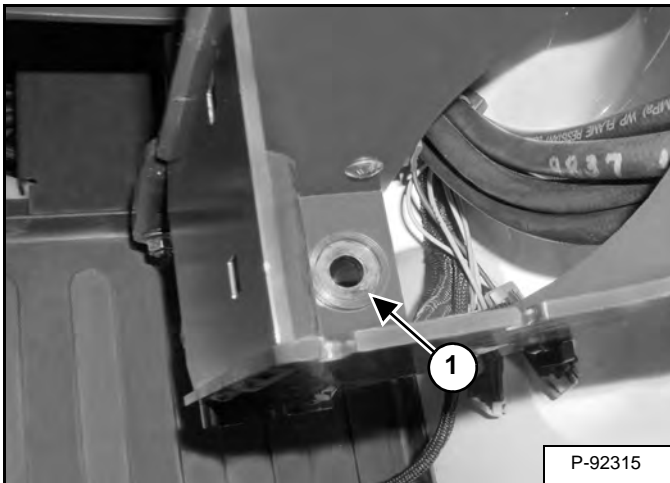

Remove the bushing (Item 1) [Figure 40-60-16] from the bottom of the console.

Figure 40-60-17

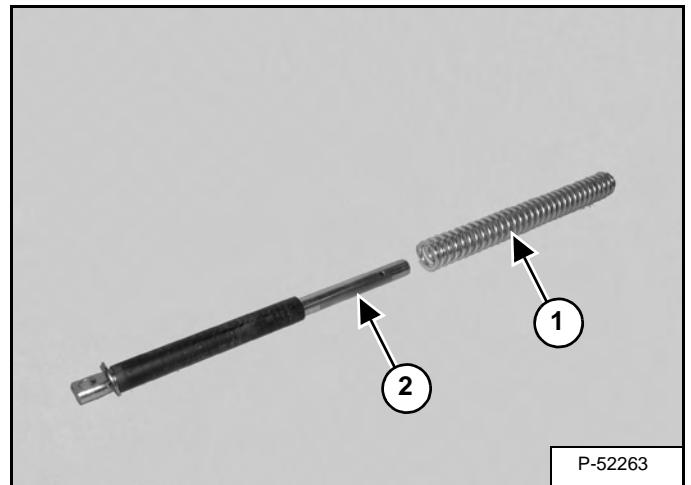

Remove the spring (Item 1) from the shaft (Item 2) [Figure 40-60-17].

Figure 40-60-18

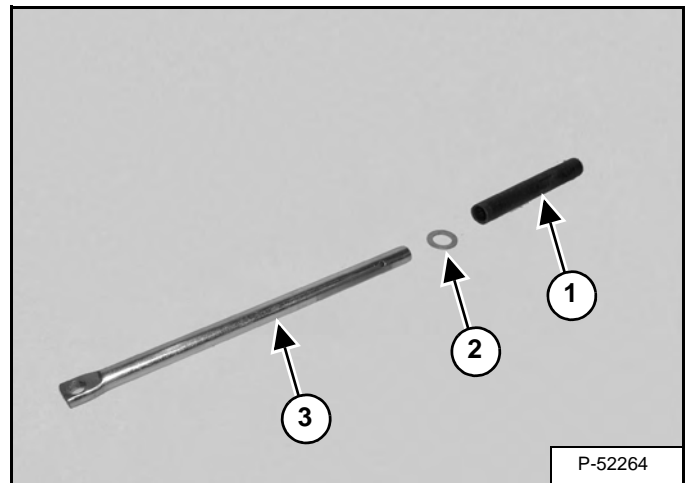

Remove the sleeve (Item 1) and washer (Item 2) from the shaft (Item 3) [Figure 40-60-18].

## TRAVEL LEVERS AND PEDALS

### Removal And Installation

Figure 40-100-1

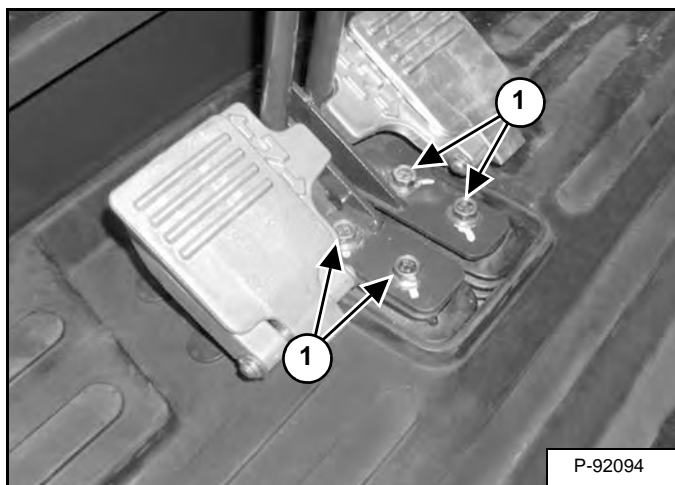

Remove the bolts (Item 1) [Figure 40-100-1].

**Installation:** Tighten the bolts to 43 - 47 N•m (32 - 35 ft-lb) torque.

## SWING FRAME (CONT'D)

### Removal And Installation (Cont'd)

Figure 40-140-8

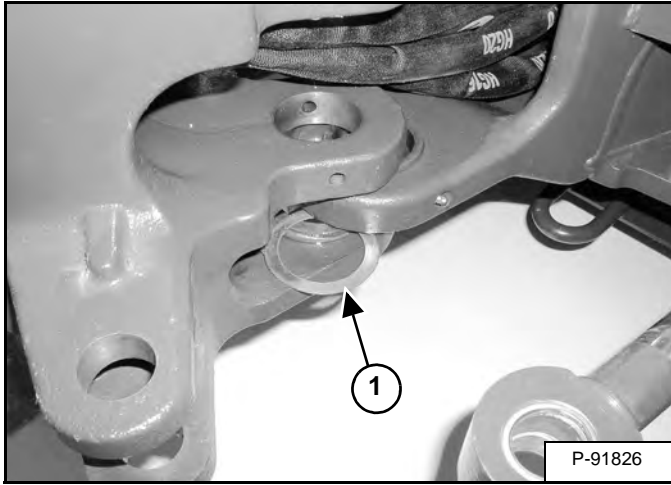

**Installation:** Install the bottom spacer (if equipped) (Item 1) [Figure 40-140-8] on the swing frame. Install the swing frame.

Figure 40-140-9

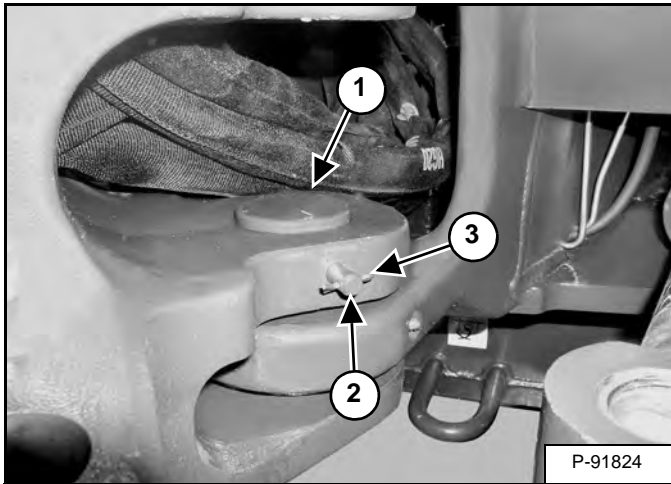

**Installation:** Align the boom swing frame and install the lower pivot pin (Item 1). Install the retaining pin (Item 2) and cotter pin (Item 3) [Figure 40-140-9]. Lift up on the boom swing frame.

Figure 40-140-10

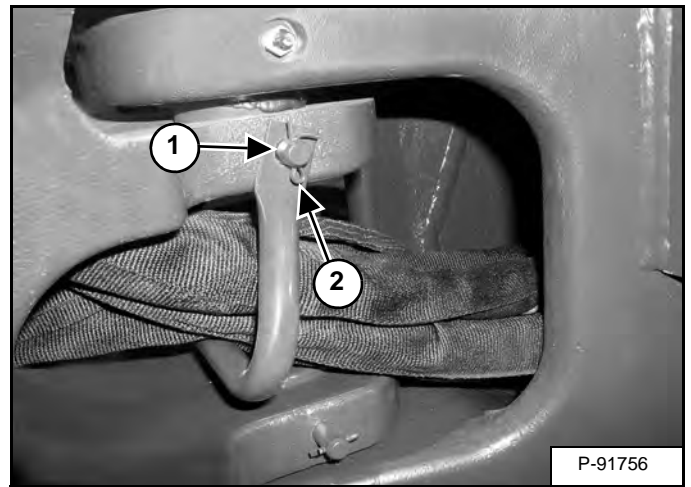

**Installation:** Install the top pivot pin, retaining pin (Item 1) and cotter pin (Item 2) [Figure 40-140-10].

## BUCKET

### Bucket Teeth Removal And Installation

# WARNING

Wear safety glasses to prevent eye injury when any of the following conditions exist:

- Pressurized fluids and springs or other stored energy components.
- Flying debris or loose material is present.
- Engine is running.
- Tools are being used.

W-2505-0604

Position the bucket so the bucket teeth are at a 30 degree angle up from the ground for accessibility to the teeth.

Lower the boom until the bucket is fully on the ground.

Stop the engine and exit the excavator.

Figure 40-170-1

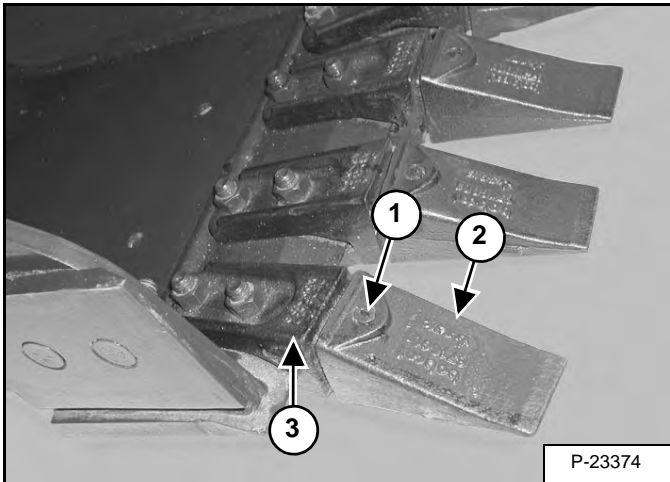

Remove the retaining pin (Item 1) from the tooth point (Item 2) [Figure 40-170-1].

Remove the tooth point (Item 2) from the shank (Item 3) [Figure 40-170-1].

Figure 40-170-2

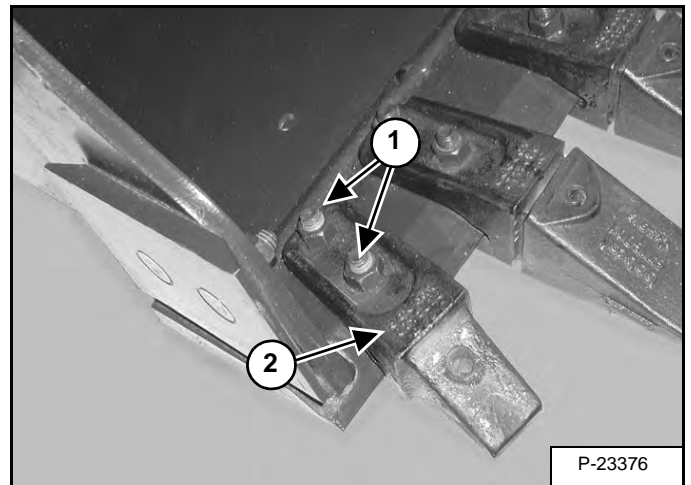

Remove the two nuts (Item 1) and bolts from the tooth shank (Item 2) [Figure 40-170-2]. Remove the tooth shank.

**Installation:** Tighten the nuts to 125 - 135 N•m (90 - 100 ft-lb) torque.

Figure 40-170-3

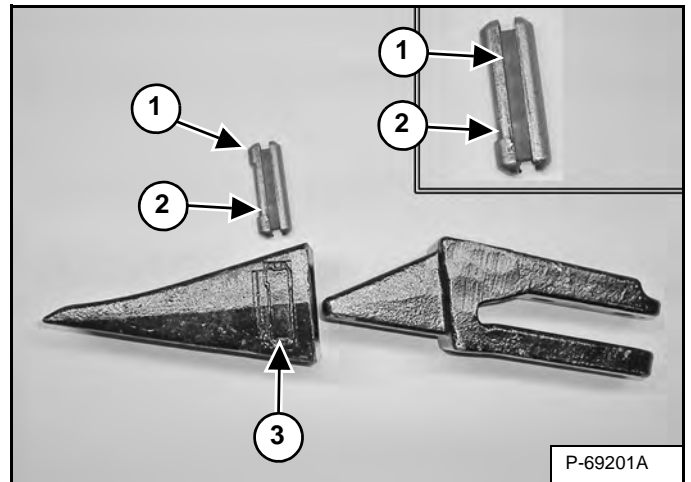

The retaining pin (Item 1) must be installed as shown [notch (Item 2) to the front] for proper fit and tooth retention. The side of the tooth point (Item 3) [Figure 40-170-3] also shows the correct orientation of the retaining pin.

**Installation:** Position the new tooth point on the shank and install a new retaining pin. Install the retaining pin until it is flush with the top of the point.

## X-CHANGE (HYDRAULIC) (EARLIER MODELS)

### Removal And Installation

Remove the bucket. (See Operation & Maintenance Manual for the correct removal procedure.)

**Figure 40-201-1**

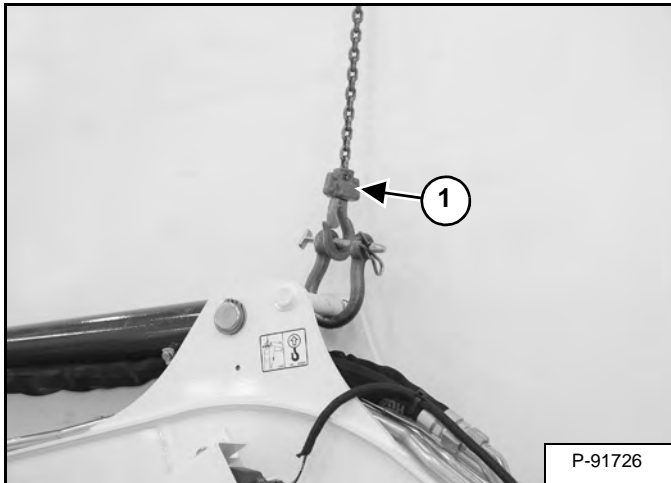

Support the boom with a hoist (Item 1) [Figure 40-201-1] and release the pressure on the boom cylinder.

**Figure 40-201-2**

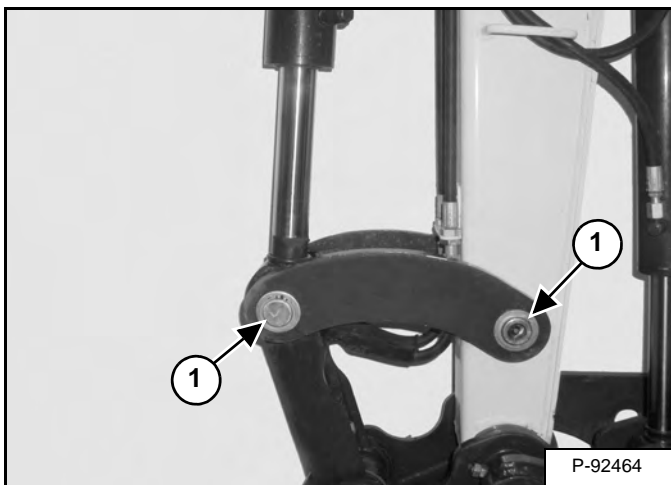

Remove the snap rings (Item 1) [Figure 40-201-2].

**Figure 40-201-3**

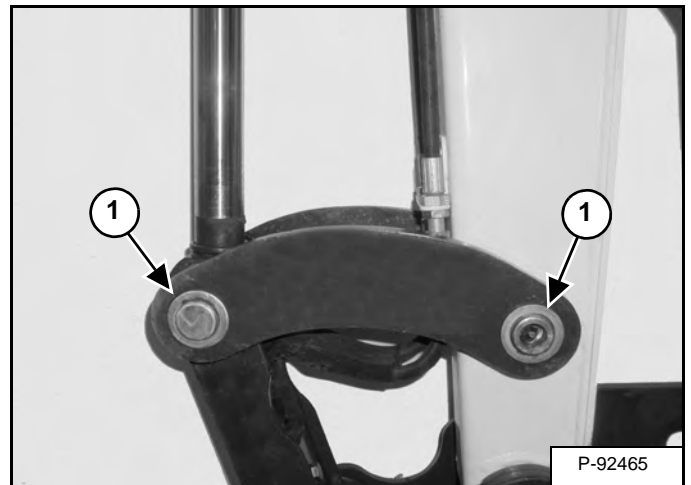

Remove the washers (Item 1) [Figure 40-201-3].

**Figure 40-201-4**

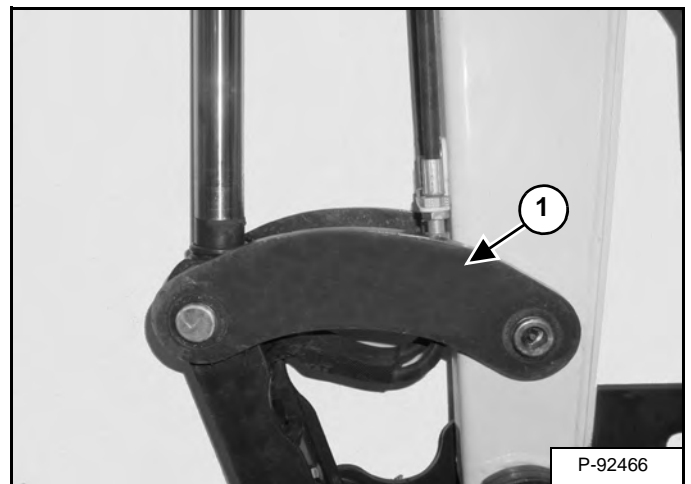

Remove the plate (Item 1) [Figure 40-201-4].

**X-CHANGE (HYDRAULIC) (EARLIER MODELS)  
(CONT'D)**

**Assembly (Cont'd)**

**Figure 40-201-37**

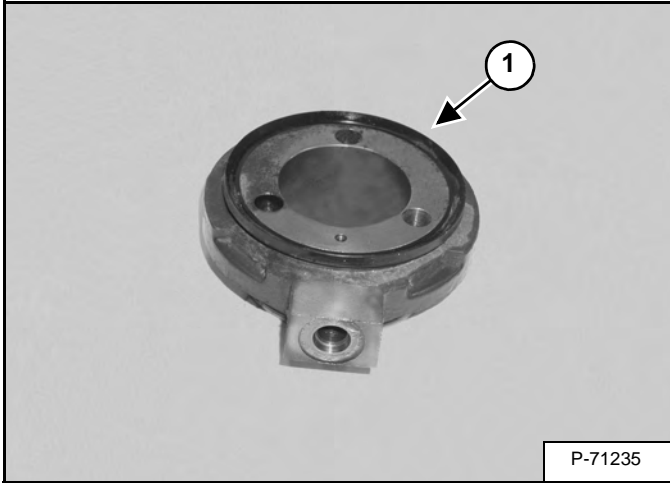

Install the dust seal (Item 1) [Figure 40-201-37] on the swivel.

**Figure 40-201-38**

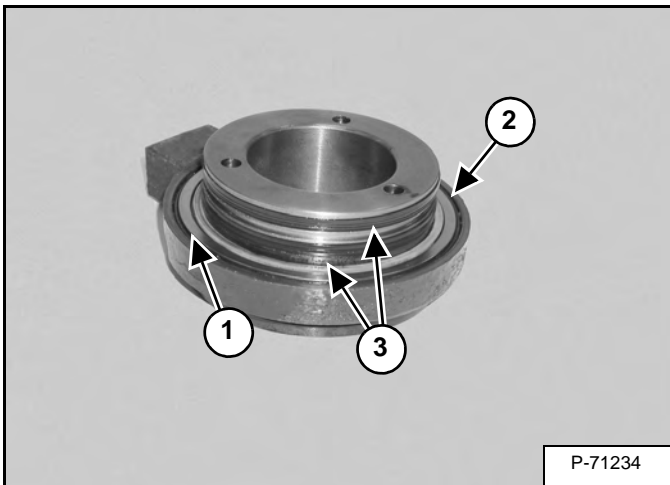

Install the O-ring (Item 1) wear ring (Item 2) and seals (Item 3) [Figure 40-201-38].

**Figure 40-201-39**

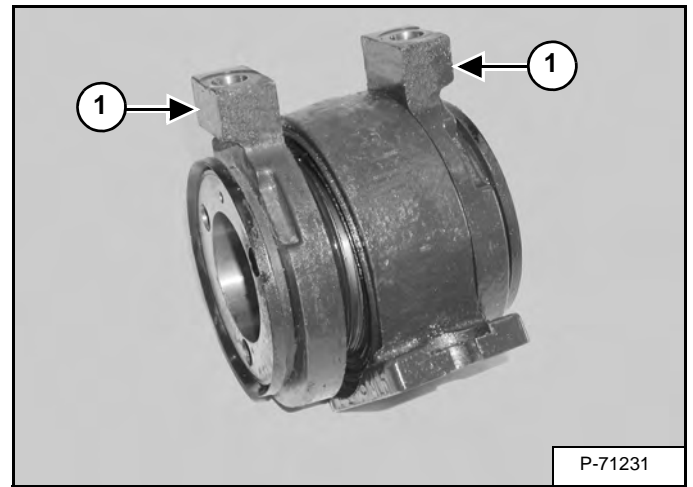

Install the swivel ends (Item 1) [Figure 40-201-39] onto the base.

**Figure 40-201-40**

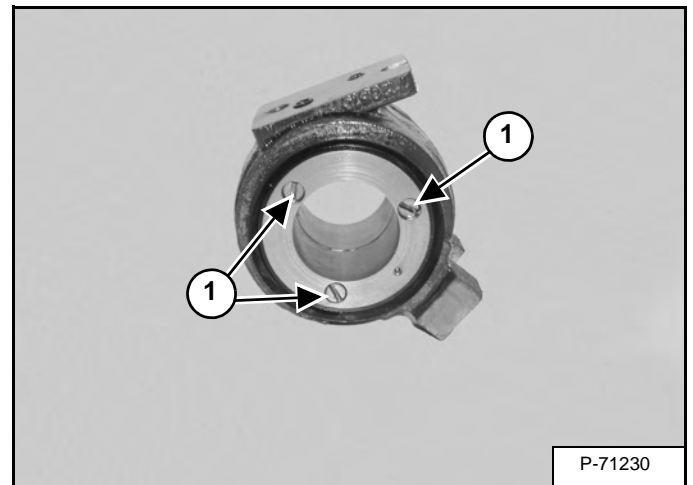

Install the screws (Item 1) [Figure 40-201-40] and nuts in the swivel assembly. Do not tighten at this time.

**X-CHANGE (HYDRAULIC) (LATER MODELS)  
(CONT'D)**

**Disassembly (Cont'd)**

**Figure 40-202-13**

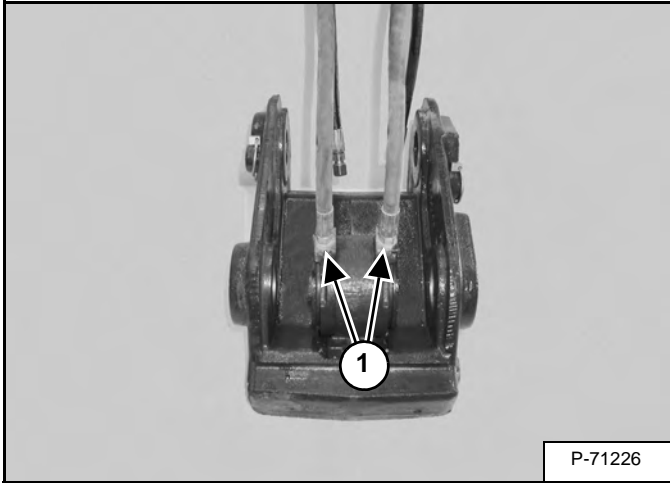

Remove the two hydraulic hoses (Item 1) [Figure 40-202-13] from the swivel ends.

**Figure 40-202-14**

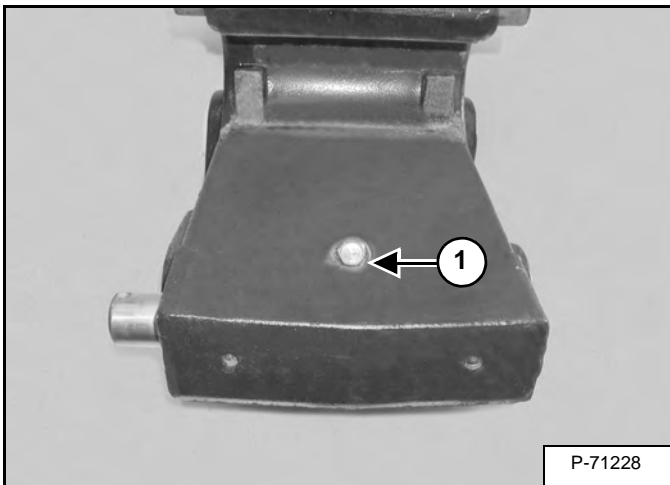

Remove the bolt (Item 1) [Figure 40-202-14].

**Figure 40-202-15**

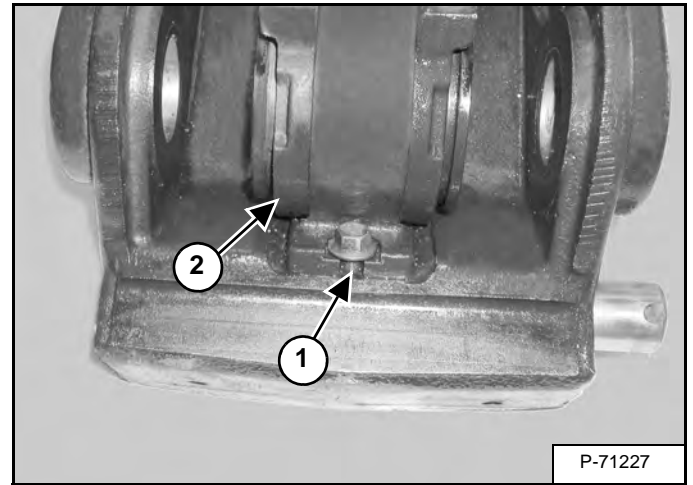

Remove the bolt (Item 1), nut, and the swivel assembly (Item 2) [Figure 40-202-15].

**Figure 40-202-16**

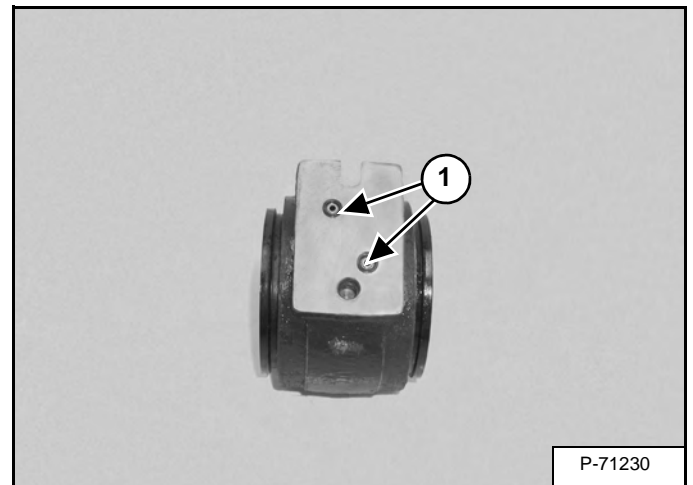

Remove the O-rings (Item 1) [Figure 40-202-16] from the swivel assembly.

**X-CHANGE (HYDRAULIC) (LATER MODELS)  
(CONT'D)**

**Assembly (Cont'd)**

**Figure 40-202-50**

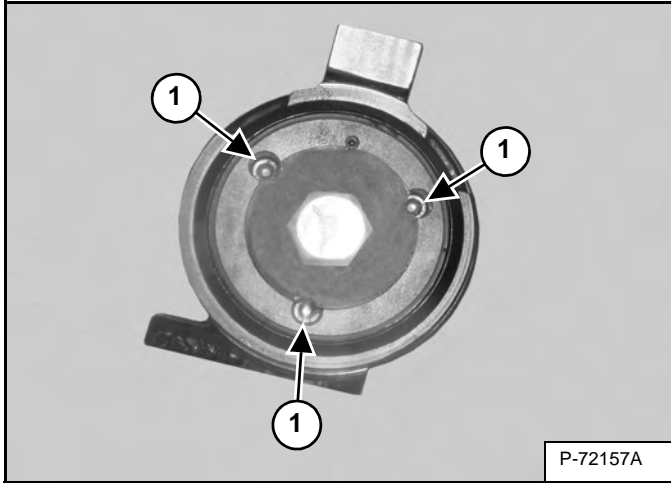

Tighten the swivel assembly screws (Item 1) [Figure 40-202-50] to 14,2 - 15,8 N•m (10.4 - 11.6 ft-lb) torque.

Remove the preload tool.

**Figure 40-202-51**

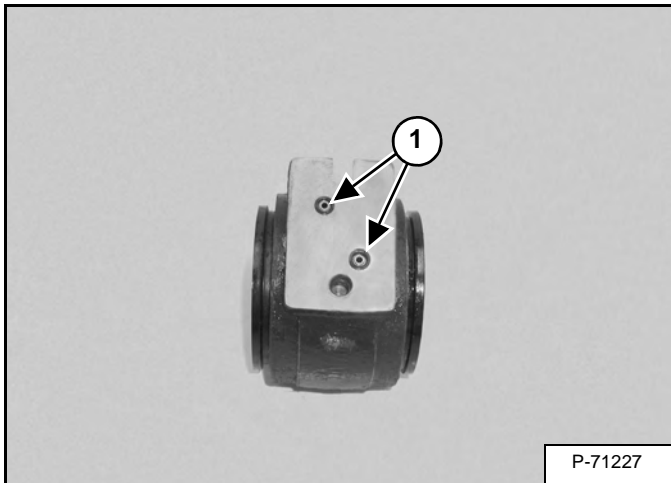

Install the two O-rings (Item 1) [Figure 40-202-51] into the swivel assembly.

**Figure 40-202-52**

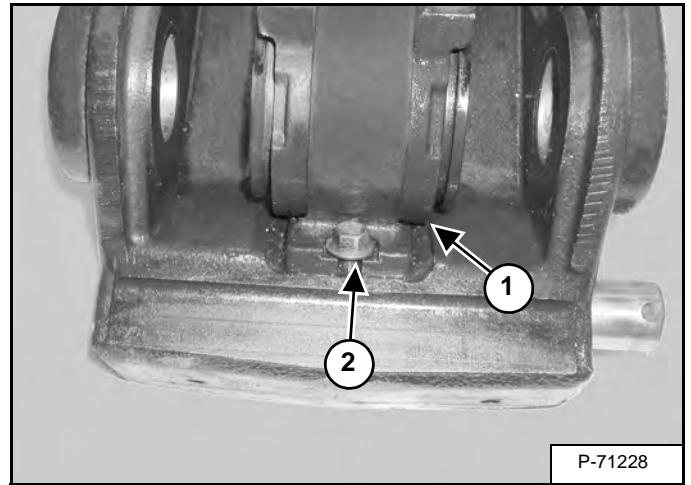

Install the swivel assembly (Item 1) using the bolt (Item 2) [Figure 40-202-52].

**Figure 40-202-53**

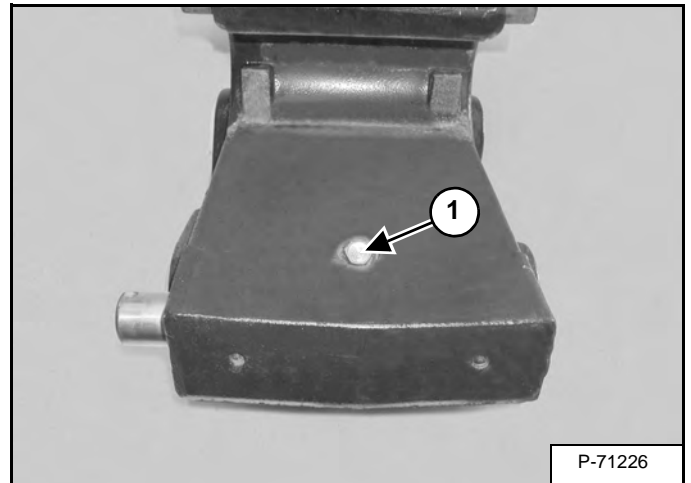

Install the bolt (Item 1) [Figure 40-202-53] and nut.

## QUICK COUPLER (KLAC™ SYSTEM) (CONT'D)

### Assembly

Figure 40-210-12

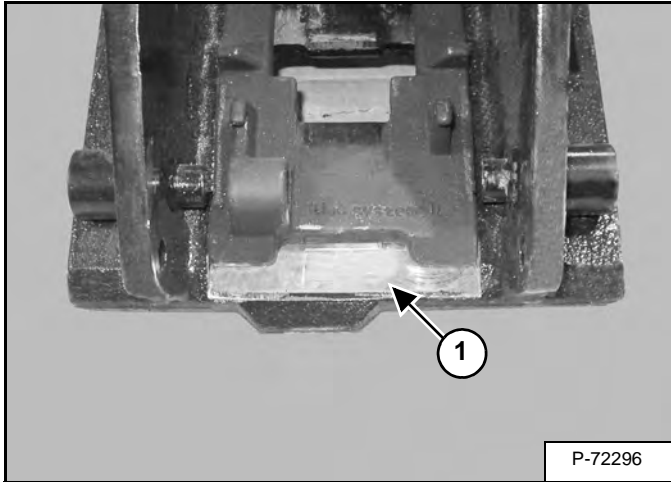

Install the latch (Item 1) [Figure 40-210-12].

Figure 40-210-13

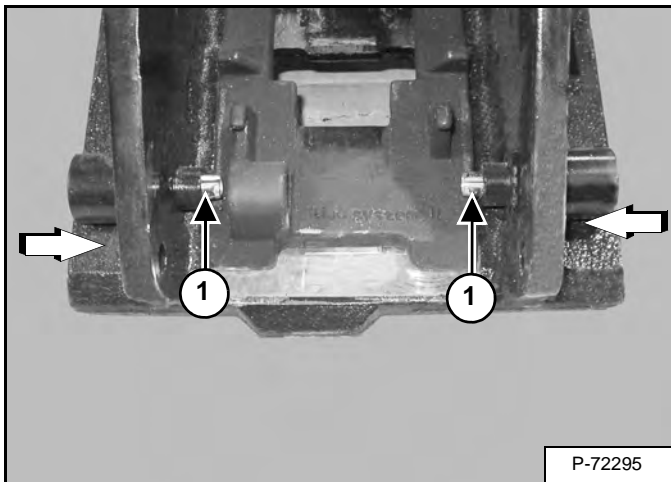

Install the two roll pins (Item 1) [Figure 40-210-13]. Drive the roll pins inwards until the roll pins are flush with the outside edge of the quick coupler.

Figure 40-210-14

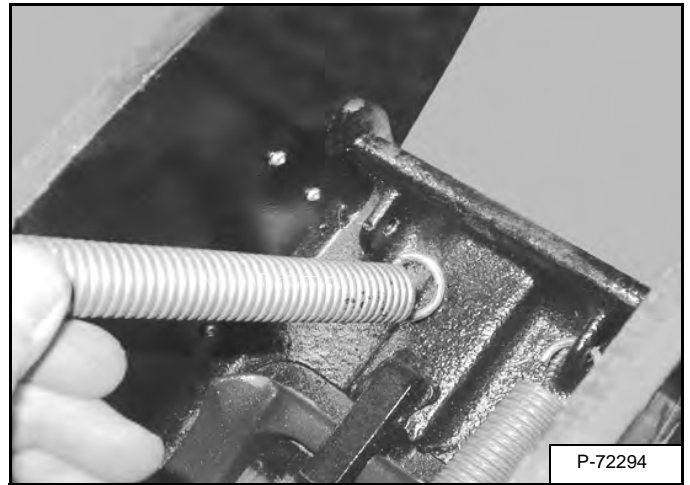

Install the partial circle hook end of the spring [Figure 40-210-14].

Figure 40-210-15

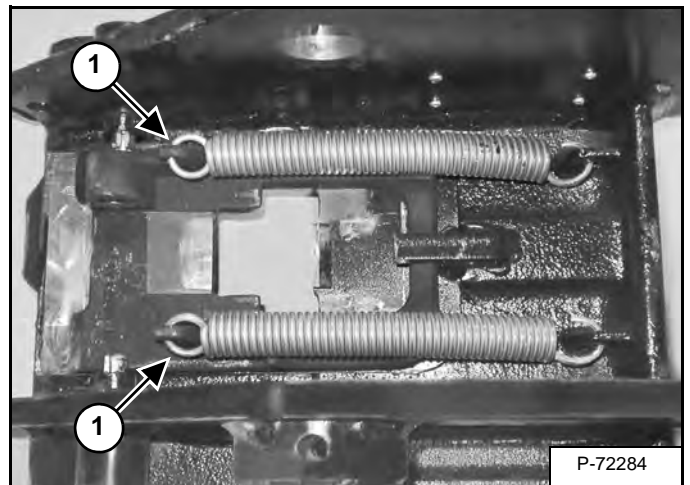

Install the full circle end of the spring hook (Item 1) [Figure 40-210-15] on the quick coupler.

Do not lubricate the quick coupler. Lubrication will cause dirt to collect and interfere with proper movement of the quick coupler.

## QUICK COUPLER (LEHNHOFF® SYSTEM) (CONT'D)

### Disassembly (MS08) (Cont'd)

Figure 40-211-18

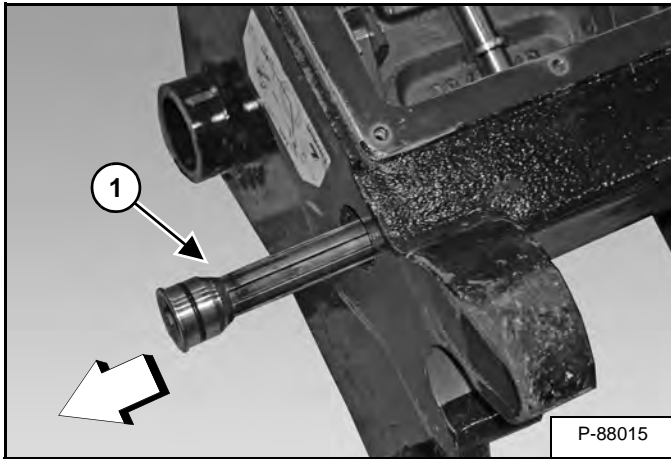

Remove the control shaft (Item 1) [Figure 40-211-18].

Figure 40-211-19

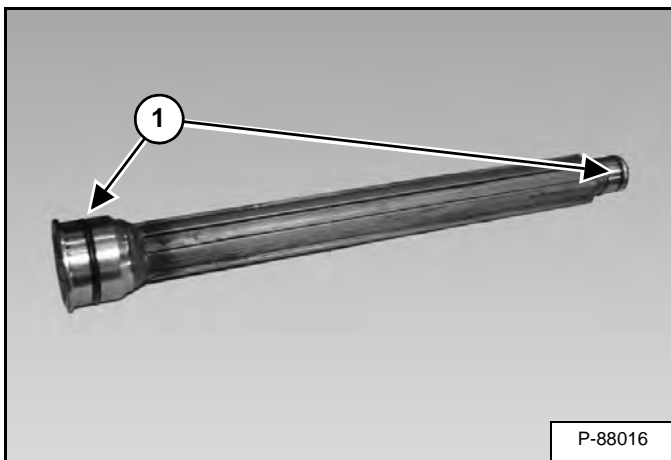

Remove O-rings (Item 1) [Figure 40-211-19].

Figure 40-211-20

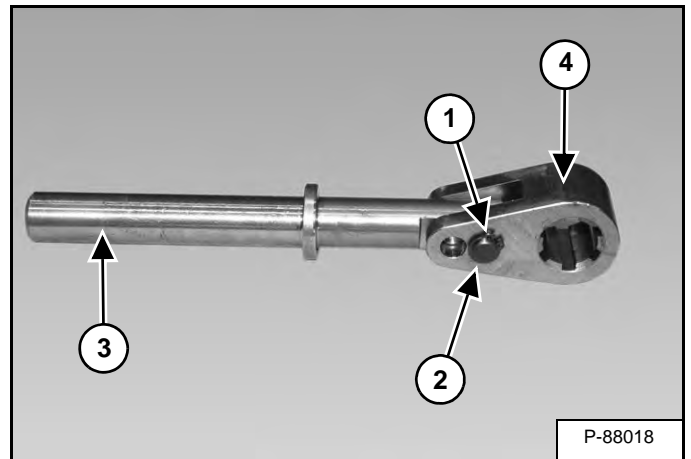

Remove the snap ring (Item 1) and pin (Item 2). Remove the spring guide (Item 3) from the driving fork (Item 4) [Figure 40-211-20].

Figure 40-211-21

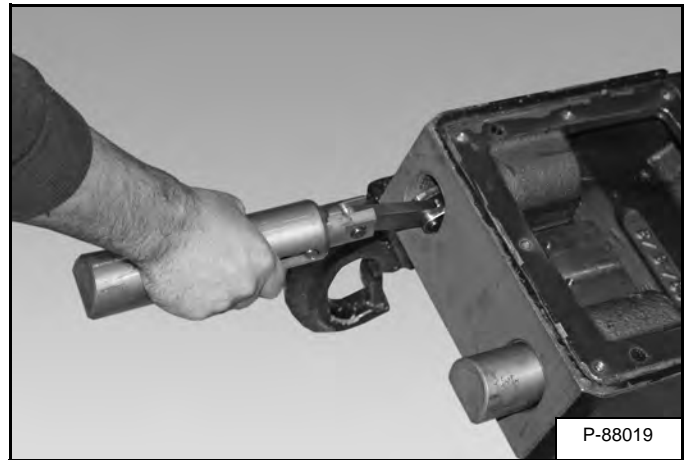

Remove the locking pin assemblies [Figure 40-211-21].

## QUICK COUPLER (PIN GRABBER) (CONT'D)

### Disassembly And Assembly

Figure 40-212-6

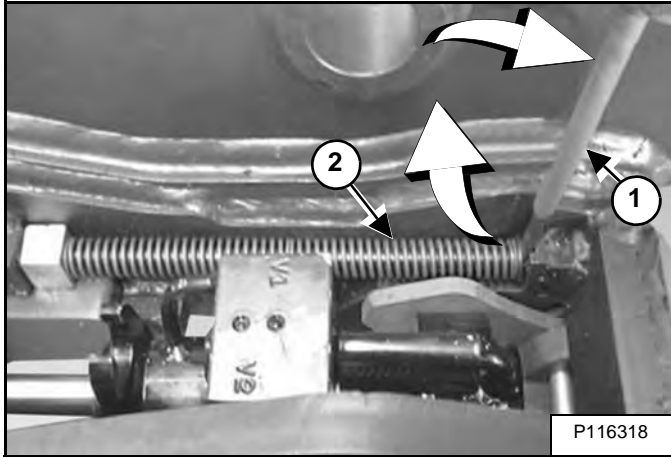

Insert a flat blade screwdriver (Item 1) at the end of the guide assembly (Item 2) [Figure 40-212-6]. Pry to compress the spring and remove the guide assembly from the frame.

Figure 40-212-7

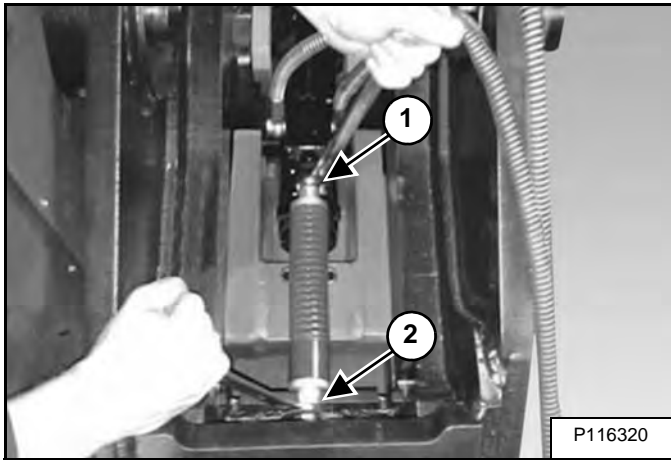

Tighten the spring assembly bolt (Item 1) and nut (Item 2) [Figure 40-212-7] until the spring assembly is free from the housing.

**NOTE: Keep the flats of the spring retainers in line with the mounts for reassembly.**

Figure 40-212-8

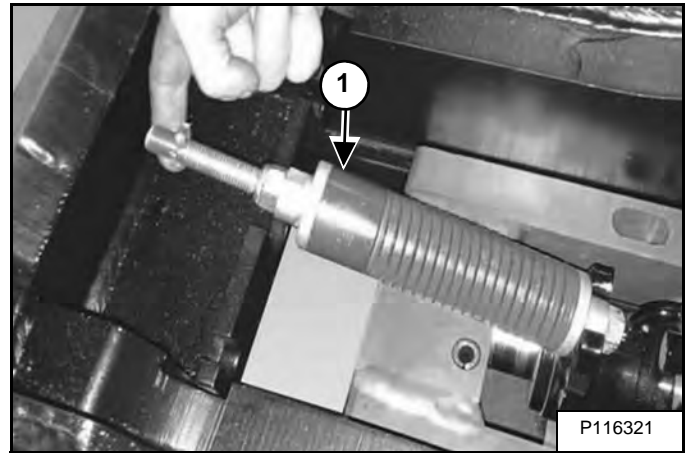

Remove the spring assembly (Item 1) [Figure 40-212-8].

Figure 40-212-9

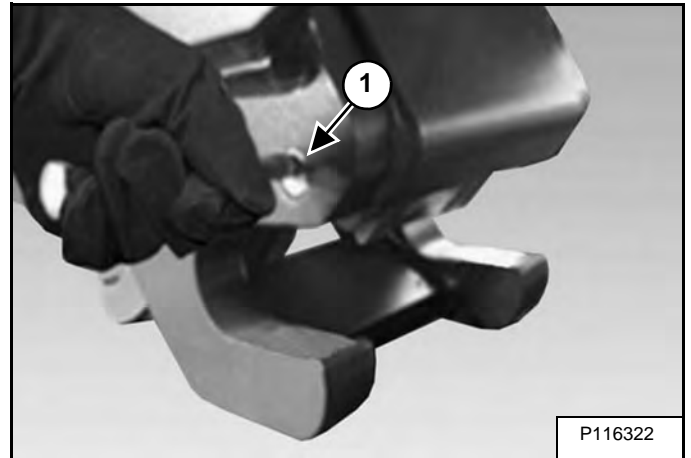

Remove safety lock pivot pin (Item 1) [Figure 40-212-9].

Figure 40-212-10

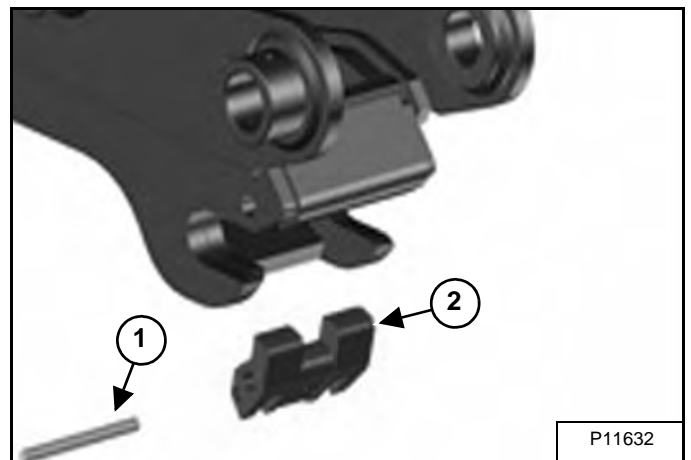

Remove the safety lock link pin (Item 1) and the safety lock (Item 2) [Figure 40-212-10].

## TOOL BOX

### Removal And Installation

Remove the floor mat and floor panel. (See Removal And Installation on Page 40-110-1.)

**Figure 40-230-1**

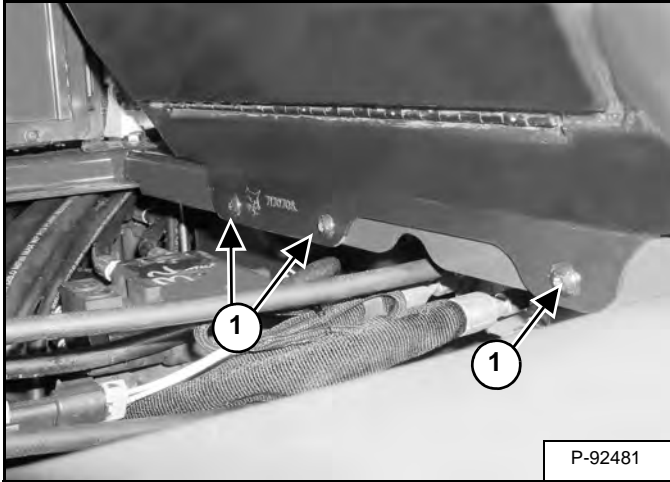

Remove the three screws (Item 1) [Figure 40-230-1].

**Figure 40-230-2**

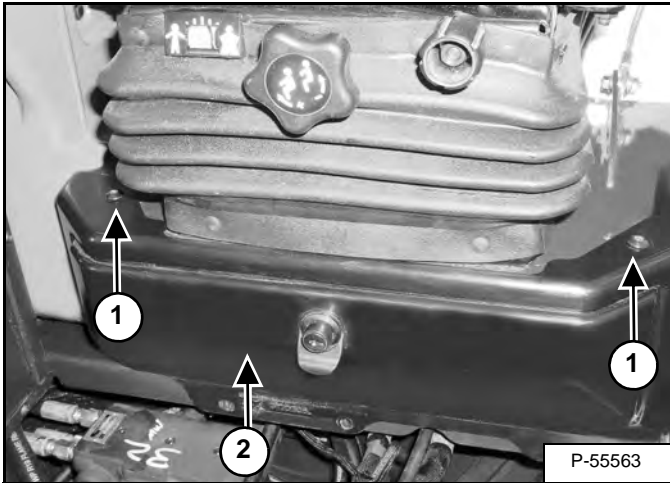

Remove the screws (Item 1) and tool box cover (Item 2) [Figure 40-230-2].

**Figure 40-230-3**

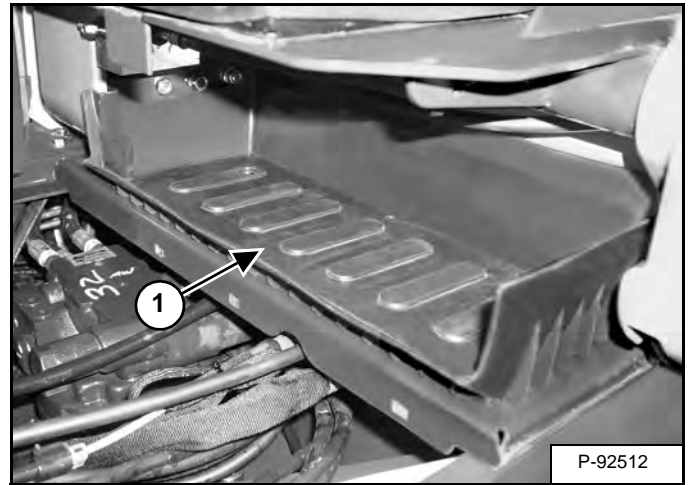

Remove the rubber liner (Item 1) [Figure 40-230-3].

**Figure 40-230-4**

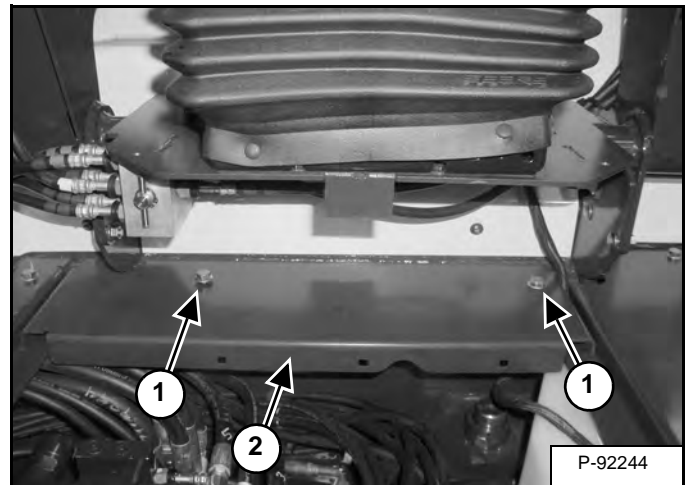

Remove the two bolts (Item 1) and floorplate (Item 2) [Figure 40-230-4].

**CONNECTORS:**

A: MCC SIDE:- 2-WAY METRI-PACK 480 SERIES  
CONN. #12065863  
MCC #31-1315  
MALE TERMINAL

B: MCC SIDE:- 3-WAY METRI-PACK 280 SERIES  
CONN. #12040977  
MCC #31-1686  
FEMALE TERMINAL

C: MCC SIDE:- 3-WAY METRI-PACK 150 SERIES  
CONN. #12110293  
MCC #31-1550  
FEMALE TERMINAL

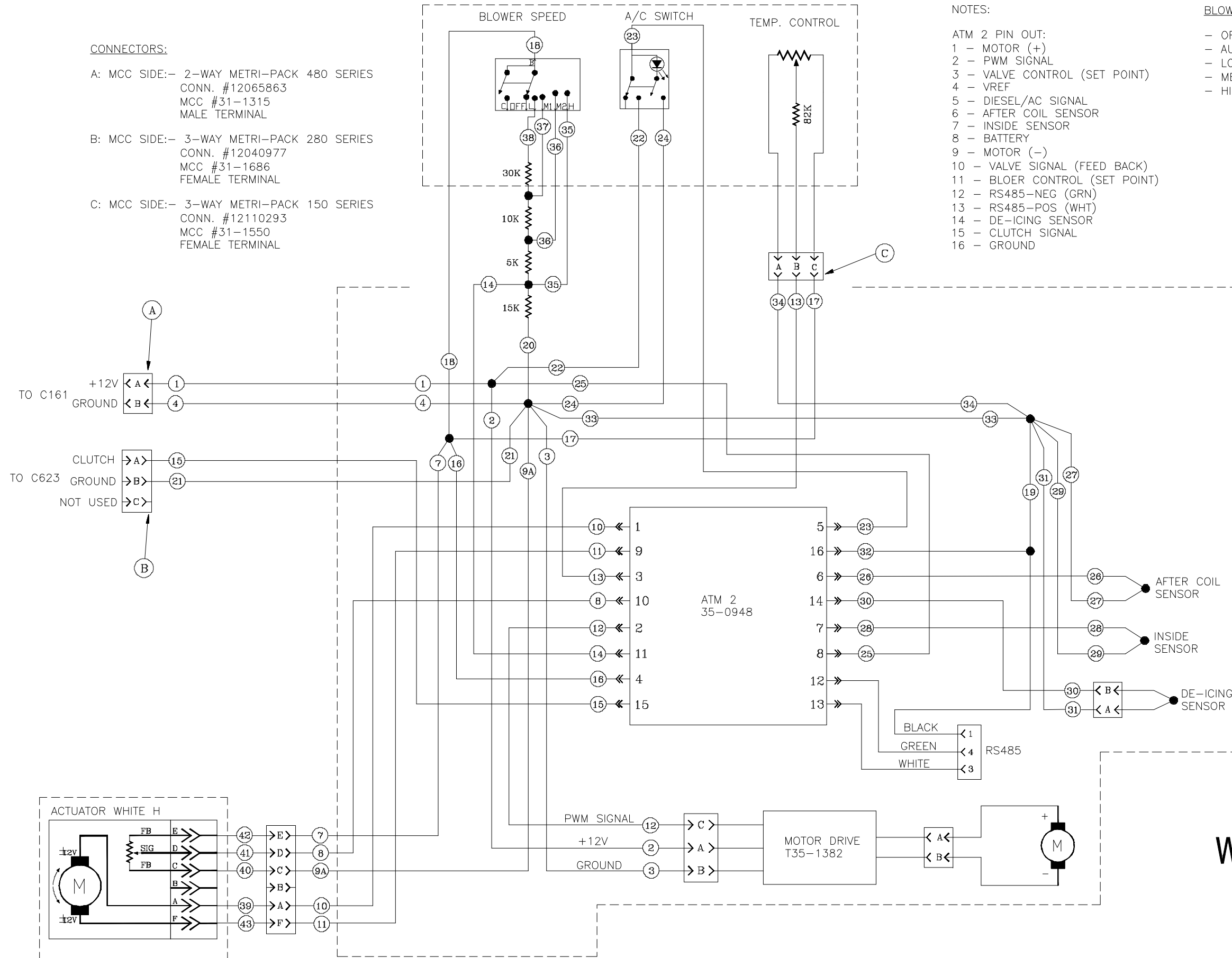

**NOTES:**

- ATM 2 PIN OUT:  
 1 - MOTOR (+)  
 2 - PWM SIGNAL  
 3 - VALVE CONTROL (SET POINT)  
 4 - VREF  
 5 - DIESEL/AC SIGNAL  
 6 - AFTER COIL SENSOR  
 7 - INSIDE SENSOR  
 8 - BATTERY  
 9 - MOTOR (-)  
 10 - VALVE SIGNAL (FEED BACK)  
 11 - BLOER CONTROL (SET POINT)  
 12 - RS485-NEG (GRN)  
 13 - RS485-POS (WHT)  
 14 - DE-ICING SENSOR  
 15 - CLUTCH SIGNAL  
 16 - GROUND

**BLOWER MODES:**

- OFF
- AUTO (L)
- LOW SPEED (M1)
- MED SPEED (M2)
- HIGH SPEED (H)

7335916 HARNESS AUTO HVAC

[Printable Version Click Here](#)

# WIRING SCHEMATIC OPTIONS

## Sheet 3 of 6

JANUARY 2019

## BATTERY (CONT'D)

### Removing And Installing

Open the right side cover. (See RIGHT SIDE COVER on Page 10-60-1.)

Figure 50-20-3

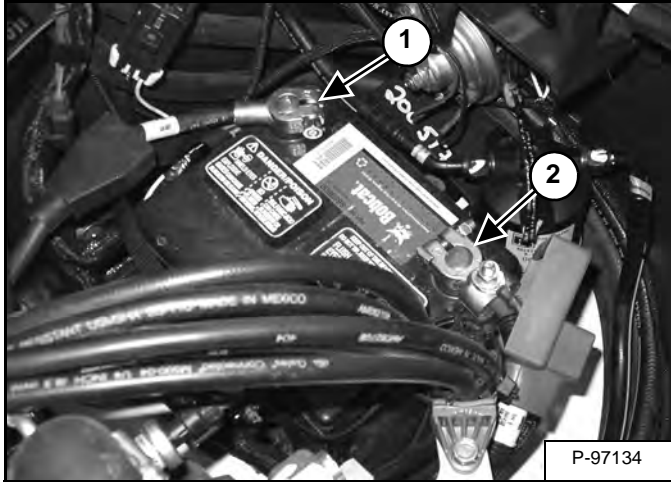

Disconnect the negative (-) cable (Item 1) [Figure 50-20-3] first.

Disconnect the positive (+) cable (Item 2) [Figure 50-20-3].

Figure 50-20-4

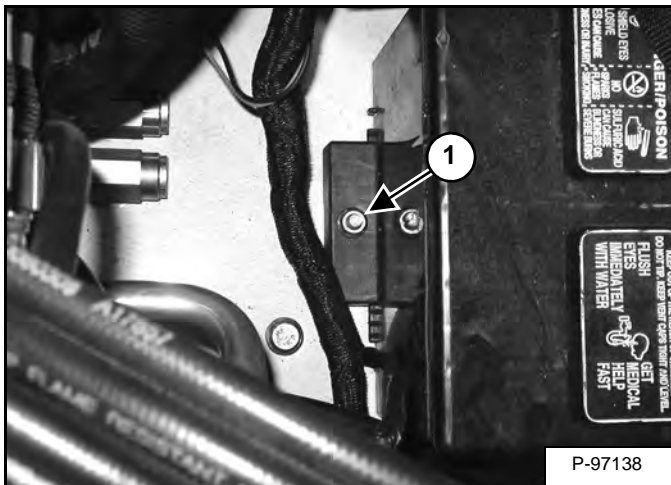

Remove the bolt (Item 1) [Figure 50-20-4] and remove the hold down clamp.

Remove the battery.

Always clean the terminals and the cable ends, even when installing a new battery.

Install the battery. Install the hold down clamp and tighten the bolts.

Connect the battery cables. Connect the negative (-) cable (Item 1) [Figure 50-20-3] last to prevent sparks.

## WARNING

### AVOID INJURY OR DEATH

Batteries contain acid which burns eyes and skin on contact. Wear goggles, protective clothing and rubber gloves to keep acid off body.

In case of acid contact, wash immediately with water. In case of eye contact get prompt medical attention and wash eye with clean, cool water for at least 15 minutes.

If electrolyte is taken internally drink large quantities of water or milk! DO NOT induce vomiting. Get prompt medical attention.

W-2065-0807

## WARNING

### AVOID INJURY OR DEATH

Batteries contain acid which burns eyes and skin on contact. Wear goggles, protective clothing and rubber gloves to keep acid off body.

In case of acid contact, wash immediately with water. In case of eye contact get prompt medical attention and wash eye with clean, cool water for at least 15 minutes.

If electrolyte is taken internally drink large quantities of water or milk! DO NOT induce vomiting. Get prompt medical attention.

W-2065-0807



## DIAGNOSTIC SERVICE CODES (CONT'D)

### Service Codes List (Cont'd)

CODE	DESCRIPTION	CODE	DESCRIPTION
E00063730	Cam signal fault	E00118002	Turbo temperature fault
E00063919	ECU communication error	E00118003	Turbo temperature sensor fault
E00064103	Boost control fault	E00118004	Turbo temperature sensor fault
E00064104	Boost control fault	E00118009	Turbo temperature sensor fault
E00065103	Injector #1 fault	E00118010	Turbo temperature sensor fault
E00065105	Injector #1 fault	E00118031	Turbo temperature sensor fault
E00065106	Injector #1 fault	E00122103	ECU safety monitoring fault
E00065120	Injector #1 fault	E00122104	ECU safety monitoring fault
E00065121	Injector #1 fault	E00122111	ECU safety monitoring fault
E00065131	Injector #1 fault	E00122119	ECU safety monitoring fault
E00065203	Injector #2 fault	E00122126	ECU safety monitoring fault
E00065205	Injector #2 fault	E00122127	ECU safety monitoring fault
E00065206	Injector #2 fault	E00122128	ECU safety monitoring fault
E00065220	Injector #2 fault	E00122129	ECU safety monitoring fault
E00065221	Injector #2 fault	E00122131	ECU safety monitoring fault
E00065231	Injector #2 fault	E00123901	High pressure fuel leak
E00065303	Injector #3 fault	E00134703	High pressure pump fault
E00065305	Injector #3 fault	E00134704	High pressure pump fault
E00065306	Injector #3 fault	E00134707	High pressure pump fault
E00065320	Injector #3 fault	E00148502	ECU main relay fault
E00065321	Injector #3 fault	E00148507	ECU main relay fault
E00065331	Injector #3 fault	E00148511	ECU main relay fault
E00065403	Injector #4 fault	E00161203	Injector #1 and #4 fault
E00065405	Injector #4 fault	E00161204	Injector #1 and #4 fault
E00065406	Injector #4 fault	E00161211	Injector #1 and #4 fault
E00065431	Injector #4 fault	E00161303	Injector #2 and #3 fault
E00067603	Glow plug relay fault	E00161304	Injector #2 and #3 fault
E00067604	Glow plug relay fault	E00161311	Injector #2 and #3 fault
E00067605	Glow plug relay fault	E00279103	EGR motor fault
E00072302	Camshaft position sensor fault	E00279104	EGR motor fault
E00072308	Camshaft position sensor fault	E00279105	EGR motor fault
E00073120	Knock sensor error	E00279108	EGR position fault
E00073121	Knock sensor error	E00324200	Exhaust temperature extremely high
E00107600	Rail pressure control fault	E00324203	Exhaust gas temperature sensor fault
E00107601	Rail pressure control fault	E00324204	Exhaust gas temperature sensor fault
E00107603	Rail pressure control fault	E00324216	Exhaust gas temperature sensor fault
E00107604	Rail pressure control fault	E00324600	Exhaust temperature extremely high
E00107609	Rail pressure control fault	E00324603	EGR temperature sensor fault
E00107615	Rail pressure control fault	E00324604	EGR temperature sensor fault
E00107616	Rail pressure control fault	E00324616	Exhaust gas temperature sensor fault
E00107617	Rail pressure control fault	E00325100	Differential pressure sensor fault
E00107618	Rail pressure control fault	E00325101	Differential pressure sensor fault
E00107620	Rail pressure control fault	E00325103	EGR temperature sensor fault
E00107631	Rail pressure control fault	E00325104	EGR temperature sensor fault
E00107702	ECU fault	E00325200	Exhaust temperature too high

## CONTROL PANEL SETUP (CONT'D)

### Password Setup (Keyless Start Panel)

#### Password Description

##### Master Password:

A permanent, randomly selected password set at the factory that cannot be changed. This password is used for service by the Bobcat dealer if the owner password is not known or to change the owner password.

##### Owner Password:

Allows for full use of the excavator. Must be used to change the owner password.

#### Changing The Owner Password

Turn the start switch (Item 1) [Figure 50-90-2] to the ON position to turn on the excavators electrical system.

Enter the five digit owner password using the number keys (1 through 0) if locked.

**Figure 50-90-2**

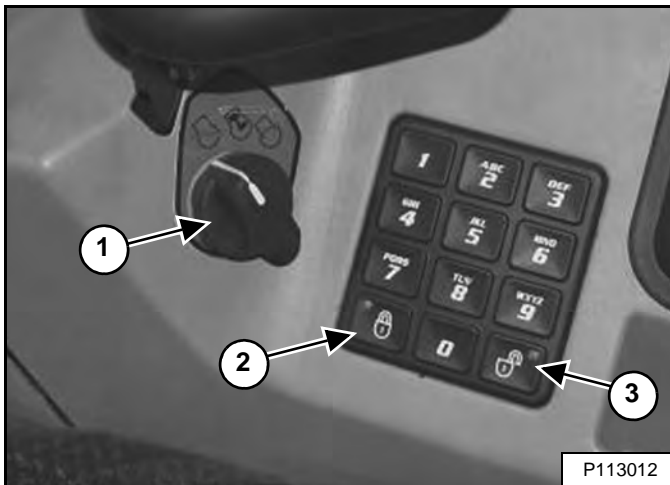

Press and hold the lock (Item 2) and unlock (Item 3) [Figure 50-90-2] keys for 2 seconds.

The lock key red light will flash and the instrument panel display screen will show [ENTER].

Enter a new five digit owner password using the number keys (1 through 0). An asterisk will show in the left panel display screen for each key press.

The instrument panel display screen will show [AGAIN].

Enter the new five digit owner password again.

The lock key red light will become solid.

#### Password Lockout Feature

This feature allows the owner to unlock the password feature so that a password does not need to be used every time the engine is started.

Turn the start switch (Item 1) [Figure 50-90-3] to the ON position to turn on the excavators electrical system.

Enter the five digit owner password using the number keys (1 through 0).

**Figure 50-90-3**

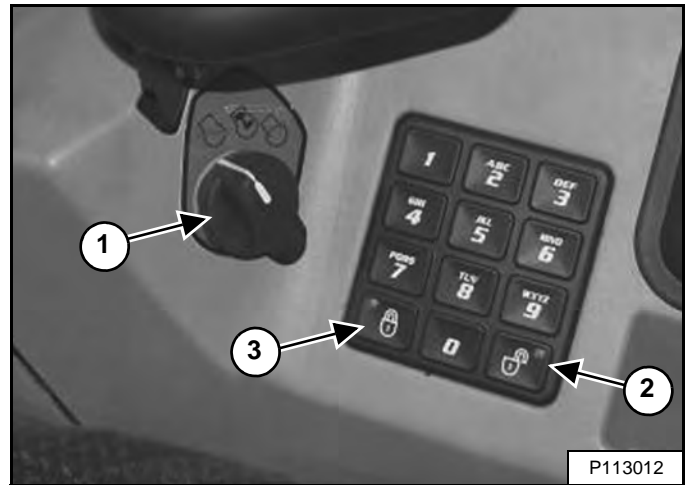

Press the unlock key (Item 2) [Figure 50-90-3].

The left panel display screen will show [CODE].

Enter the five digit owner password using the number keys (1 through 0). The unlock key green light will flash, then become solid.

The excavator can now be started without using a password.

**NOTE: Use the following procedure to reset the machine lock so that the excavator requires a password to start the engine.**

Turn the start switch to the ON position to turn on the excavators electrical system.

Press the lock key (Item 3) [Figure 50-90-3].

The lock key red light will flash and the left panel display screen will show [CODE].

Enter the five digit owner password using the number keys (1 through 0). The unlock key green light will flash, then the lock key red light will become solid.

You must now enter the password every time to start the excavator.

## CONTROLLER (GATEWAY AND AUXILIARY) (CONT'D)

### Auxiliary Controller Removal And Installation

Remove the gateway controller. (See Gateway Controller Removal And Installation on Page 50-110-1.)

Figure 50-110-8

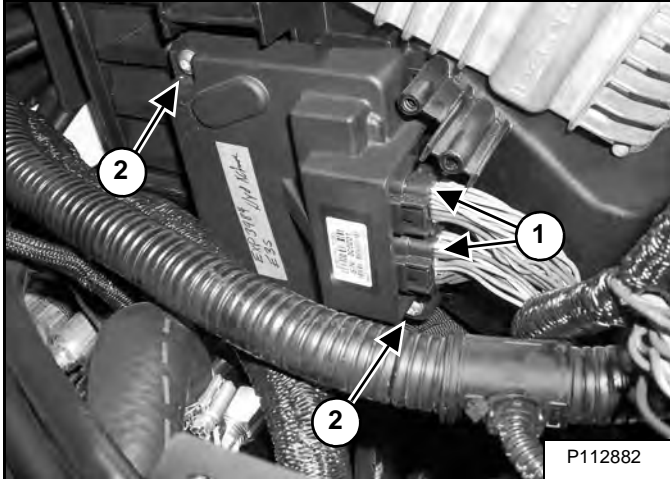

Disconnect the wire harness (Item 1). Remove the bolts (Item 2) [Figure 50-110-8] and remove the auxiliary controller from the excavator.

**Installation:** Tighten the screws to 7,9 N•m (5.8 ft-lb) torque.

**NOTE:** The wire harness connectors are keyed and will only plug in one way.

## MOTION ALARM SYSTEM

### Description

This excavator may be equipped with a motion alarm system. The motion alarm will sound when the operator moves the travel control levers in either the forward or reverse direction. Slight movement of the steering levers in either the forward or reverse direction is required with hydraulic components before the motion alarm will sound.

### Inspecting

Figure 50-150-1

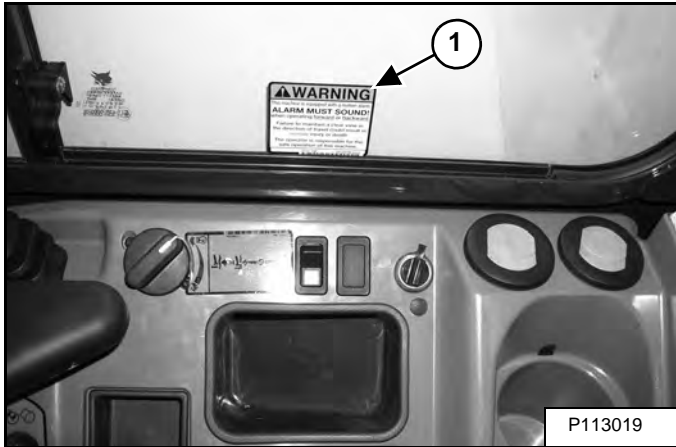

Figure 50-150-2



Inspect for damaged or missing motion alarm decal (Item 1) [Figure 50-150-1] (cab machine) or (Item 1) [Figure 50-150-2] (canopy machine). Replace if required.

**NOTE:** The excavator will need to be moved slightly in both the forward and reverse direction to test the motion alarm. Keep all bystanders away from machine during test.

## **WARNING**

### AVOID INJURY OR DEATH

**When an engine is running in an enclosed area, fresh air must be added to avoid concentration of exhaust fumes. If the engine is stationary, vent the exhaust outside. Exhaust fumes contain odorless, invisible gases which can kill without warning.**

W-2050-0807

Sit in the operator's seat and fasten the seat belt. Start the engine.

Move the travel control levers (one lever at a time) in the forward direction. The motion alarm must sound. Move the travel control levers (one lever at a time) in the reverse direction. The motion alarm must sound.

Figure 50-150-3



Slightly move both travel control levers in the forward direction (until the machine is slowly moving forward) and then press the motion alarm cancel switch (Item 1) [Figure 50-150-3]. The motion alarm will shut off. With the machine still moving forward, move one of the levers to the neutral position, the motion alarm must sound.

Slightly move both travel control levers in the reverse direction (until the machine is slowly moving backward) and then press the motion alarm cancel switch (Item 1) [Figure 50-150-3] (the switch icon will be illuminated when the motion alarm is deactivated). The motion alarm will shut off. With the machine still moving backward, move one of the levers to the neutral position, the motion alarm must sound.

Return both levers to neutral and turn excavator key to OFF position. Exit the excavator.

## TRAVEL MOTOR AUTO-SHIFT (CONT'D)

### Troubleshooting (Cont'd)

Failure Mode	Causes	Symptom	Troubleshooting	Controller Response
Load sense pressure sensor not working.	Failed sensor.	Travel motors will not auto-shift from high range to low range.	Service code will be displayed.	Service code detected, and software allows travel motors to be manually upshifted or downshifted with the two-speed switch.
	Wire harness disconnected.			
	Wire harness or connectors damaged.			
	Short to battery.			
	Short to ground.			
Hydraulic oil temperature sensor not working.	Failed sensor.	Auto shift feature will not function correctly.	Service code will be displayed.	Service code detected.
	Wire harness disconnected.			
	Wire harness or connectors damaged.			
	Short to battery.			
	Short to ground.			
Load sense relief valve setting is low.	Load sense relief valve setting is low.	Travel motors will not auto-shift from high range to low range, because machine reaches load sense relief pressure before reaching down shift pressure setting.	Test and adjust the load sense relief valve as outlined under pump testing.	No service code shown.

## ENGINE SERVICE

ENGINE INFORMATION .....	60-10-1
Description .....	60-10-1
Specifications .....	60-10-2
Sensor Location .....	60-10-4
Torque Values .....	60-10-10
Troubleshooting .....	60-10-12
Engine Removal And Installation .....	60-10-14
Compression - Testing (Using Glow Plug Compression Adapter) .....	60-10-22
Compression - Testing (Using Injector Compression Adapter) .....	60-10-24
Injector Signal - Testing .....	60-10-26
Injector Signal - Testing (In-Line) .....	60-10-28
DIESEL OXIDATION CATALYST (DOC) .....	60-20-1
Removal And Installation .....	60-20-1
AIR CLEANER .....	60-30-1
Housing Removal And Installation .....	60-30-1
ENGINE COOLING SYSTEM .....	60-40-1
Radiator Removal And Installation .....	60-40-1
Fan Removal And Installation .....	60-40-4
Water Pump Removal And Installation .....	60-40-5
Thermostat Housing Removal And Installation .....	60-40-6
Testing The Thermostat .....	60-40-7
LUBRICATION SYSTEM .....	60-50-1
Description .....	60-50-1
Oil Pan Removal And Installation .....	60-50-2
Oil Pump Removal And Installation .....	60-50-3
Oil Pump Relief Valve Description .....	60-50-4
Oil Pump Relief Valve Removal And Installation .....	60-50-4
Oil Cooler Removal And Installation .....	60-50-4
Oil Filter Head Removal And Installation .....	60-50-5
Oil Cooler Bypass Description .....	60-50-5
Oil Cooler Bypass Removal And Installation .....	60-50-5
FUEL SYSTEM .....	60-60-1
Description .....	60-60-1
Transfer Pump / High Pressure Pump Removal And Installation .....	60-60-2
Fuel Temperature Sensor Removal And Installation .....	60-60-5
Fuel Cooler Removal And Installation .....	60-60-6
Fuel Bypass Valve Removal And Installation .....	60-60-7
Fuel Recirculation Valve Removal And Installation .....	60-60-8
Fuel Injector Removal And Installation .....	60-60-9
Removing Air From The Fuel System .....	60-60-12

**ENGINE INFORMATION (CONT'D)**

**Sensor Location (Cont'd)**

**Figure 60-10-9**

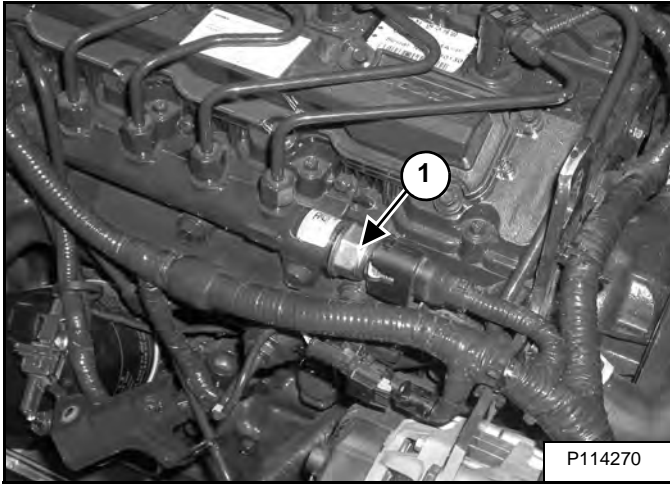

Fuel rail pressure sensor (Item 1) [Figure 60-10-9].

**Figure 60-10-10**

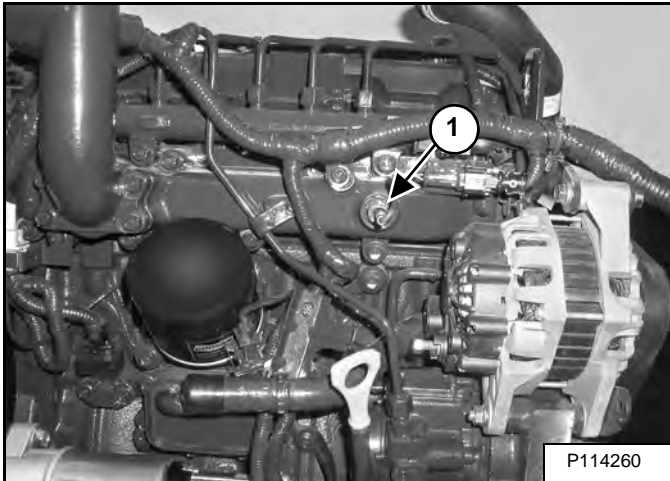

Intake manifold temperature sensor (Item 1) [Figure 60-10-10].

**Figure 60-10-11**

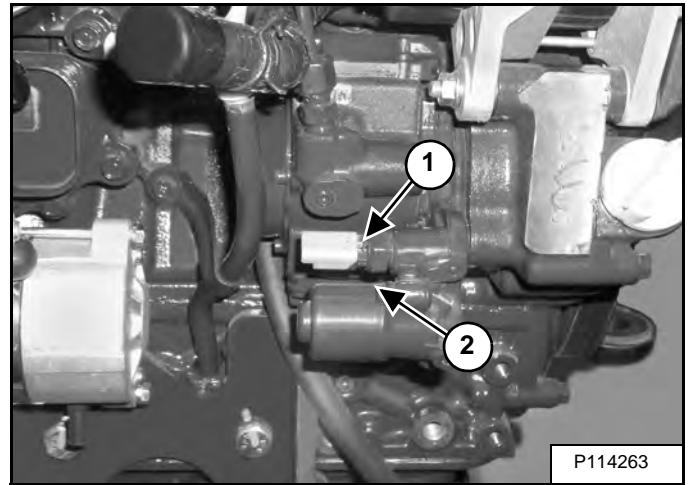

Fuel temperature sensor (Item 1) [Figure 60-10-11].

Inlet metering valve (Item 2) [Figure 60-10-11].

**Figure 60-10-12**

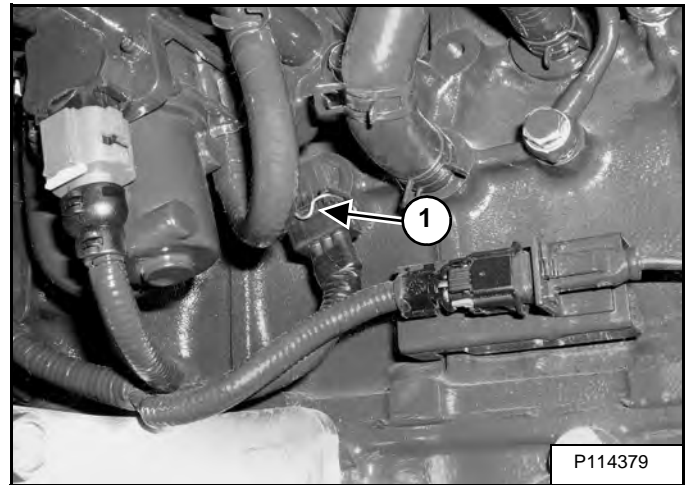

Camshaft position sensor (Item 1) [Figure 60-10-12].

## ENGINE INFORMATION (CONT'D)

### Engine Removal And Installation (Cont'd)

Figure 60-10-29

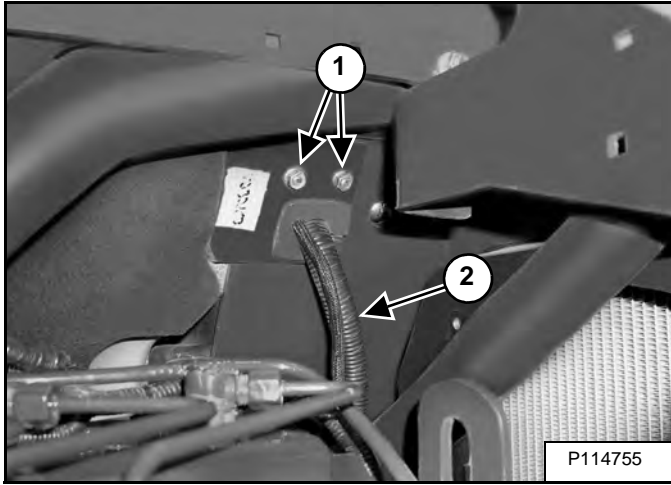

Remove the bolts (Item 1) and cover. Pull the wire harness (Item 2) [Figure 60-10-29] into the engine compartment.

Figure 60-10-30

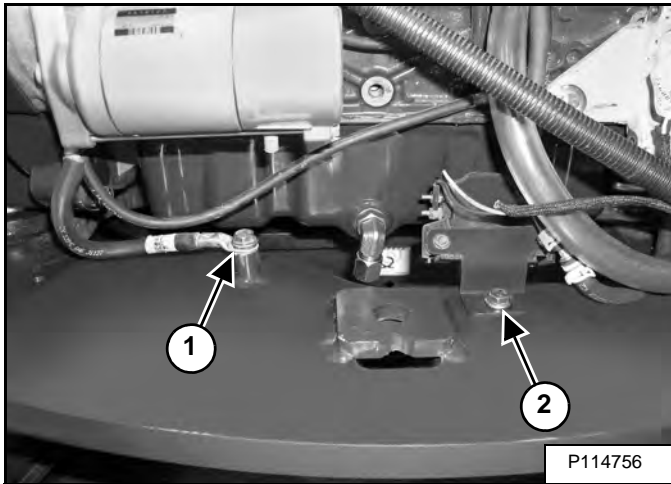

Remove the bolt (Item 1) and ground cable from the excavator frame. Remove the bolt (Item 2) [Figure 60-10-30] and relocate the motion alarm.

Figure 60-10-31

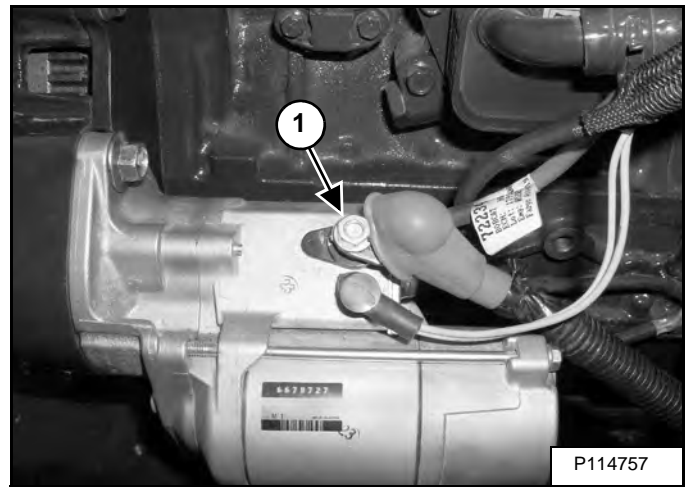

Remove the cable (Item 1) [Figure 60-10-31] from the starter.

Figure 60-10-32

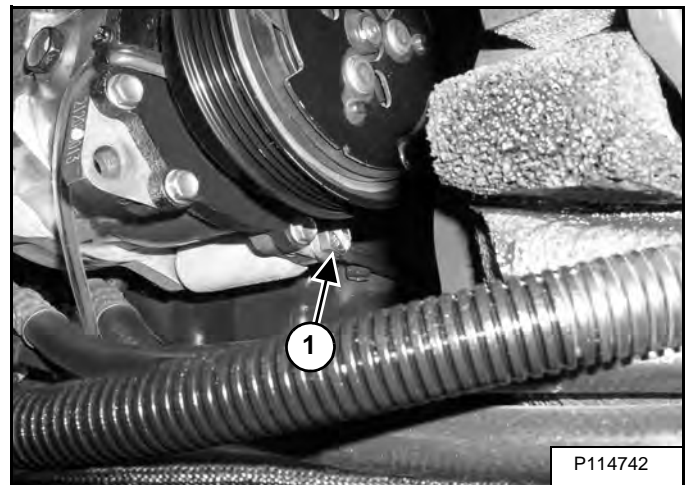

Remove the bolt (Item 1) [Figure 60-10-32] and nut.

## ENGINE INFORMATION (CONT'D)

### Injector Signal - Testing (Cont'd)

Figure 60-10-55

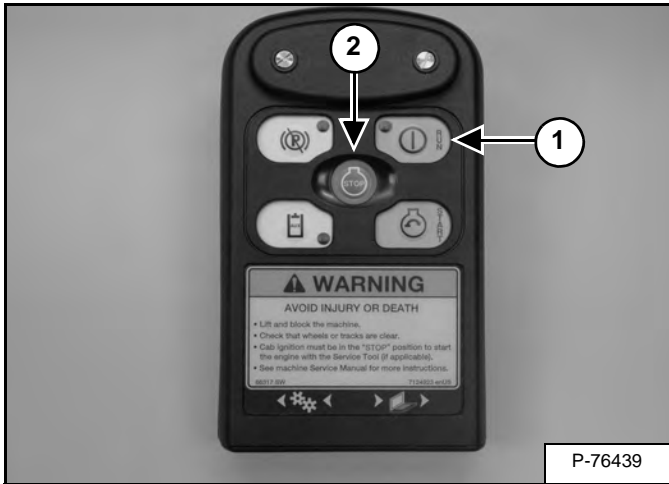

Press the RUN button (Item 1) [Figure 60-10-55] on the Remote Start Tool.

Figure 60-10-56

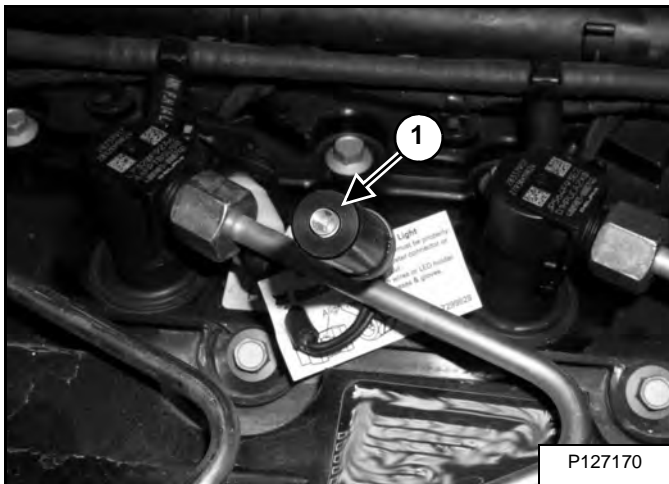

The signal tester light (Item 1) [Figure 60-10-56] should flash once.

To repeat the test, press the STOP button (Item 2) [Figure 60-10-55] and wait one minute.

If the signal tester light flashes, the electrical system is working.

If the signal tester light is on continuously or not at all, there is an electrical malfunction.

Repeat the above procedure for the remaining injectors.

## ENGINE COOLING SYSTEM (CONT'D)

### Radiator Removal And Installation (Cont'd)

Figure 60-40-10

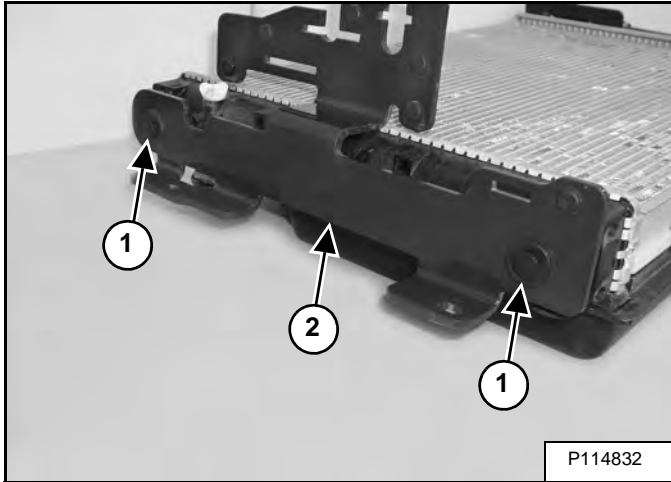

Remove the plastic fasteners (Item 1) and remove the bottom mount (Item 2) [Figure 60-40-10].

Figure 60-40-11

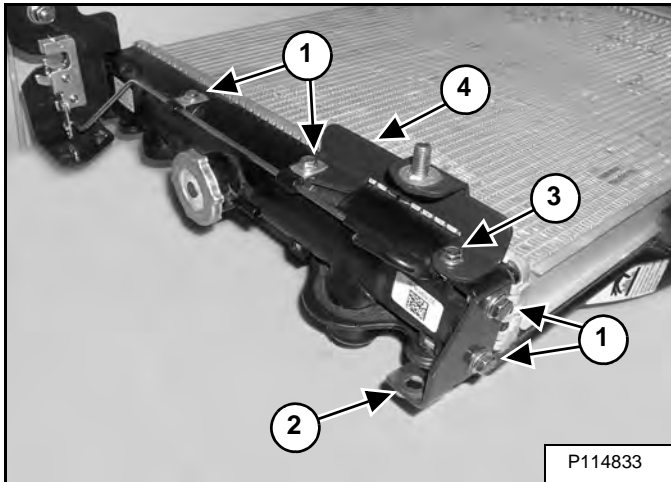

Remove the bolts (Item 1) and the mount (Item 2) [Figure 60-40-11].

Remove the bolts (Item 3) and the mount (Item 4) [Figure 60-40-11].

Figure 60-40-12

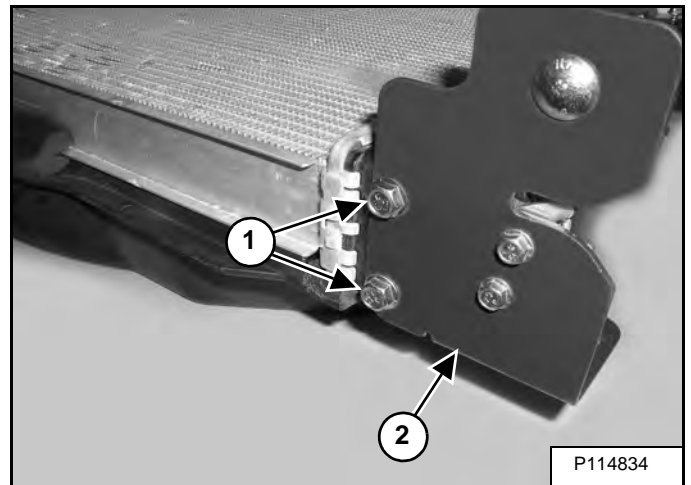

Remove the bolts (Item 1) and the mount / latch assembly (Item 2) [Figure 60-40-12].

Figure 60-40-13

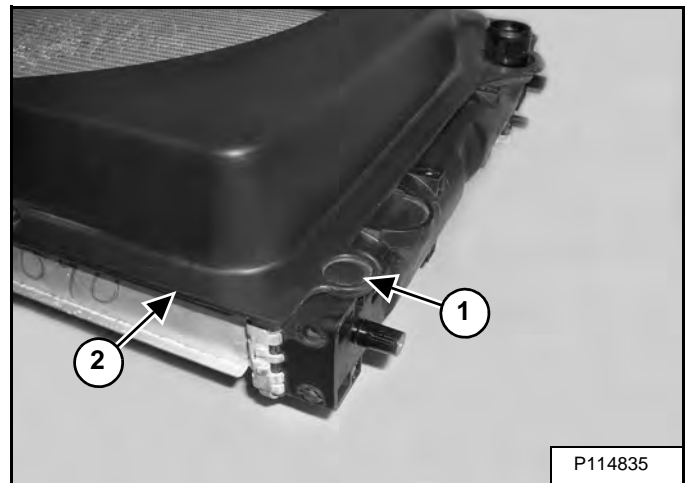

Remove the four plastic fasteners (Item 1) and remove the shroud (Item 2) [Figure 60-40-13].

## LUBRICATION SYSTEM (CONT'D)

### Oil Filter Head Removal And Installation

Remove the oil cooler. (See Oil Cooler Removal And Installation on Page 60-50-4.)

Figure 60-50-12

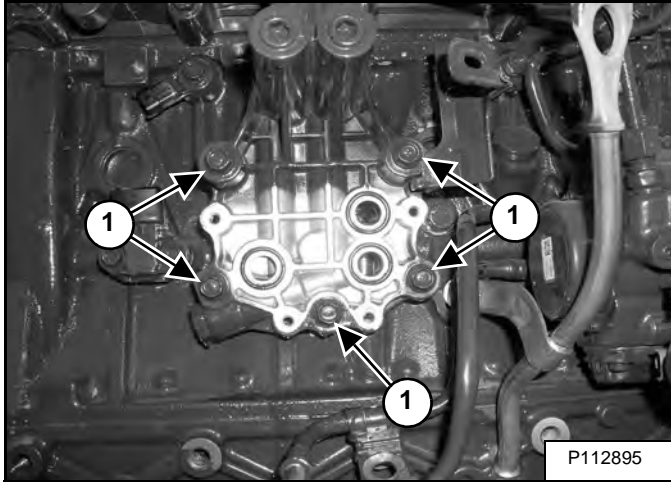

Remove the bolts (Item 1) [Figure 60-50-12] and remove the filter head.

**Installation:** Tighten the bolts to 22 N•m (16 ft-lb) torque.

Figure 60-50-13

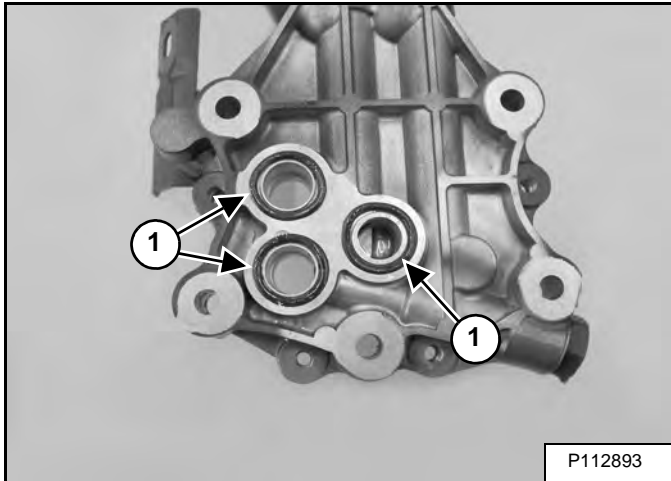

Remove the O-rings (Item 1) [Figure 60-50-13].

### Oil Cooler Bypass Description

The oil cooler bypass is set to 145 kPa (1,4 bar) (21 psi).

### Oil Cooler Bypass Removal And Installation

Figure 60-50-14

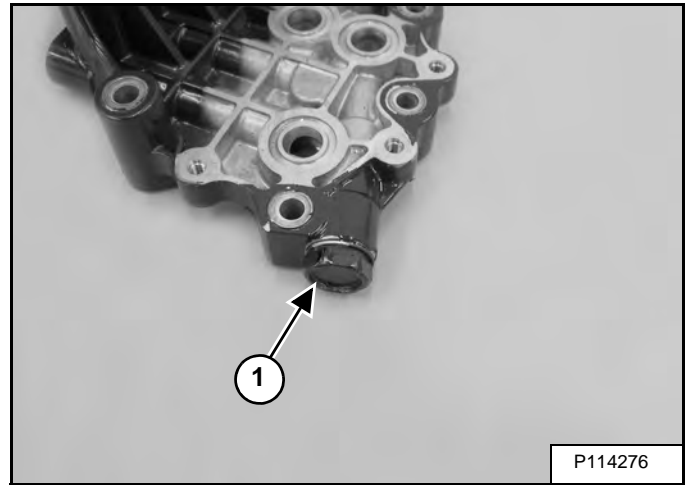

Remove the plug (Item 1) [Figure 60-50-14].

Figure 60-50-15

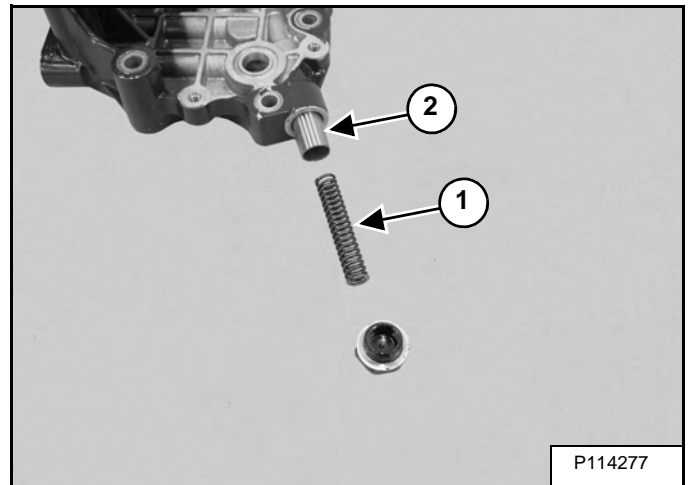

Remove the spring (Item 1) and poppet (Item 2) [Figure 60-50-15].

## FUEL SYSTEM (CONT'D)

### Fuel Recirculation Valve Removal And Installation (Cont'd)

Later Model (Cont'd)

Figure 60-60-27

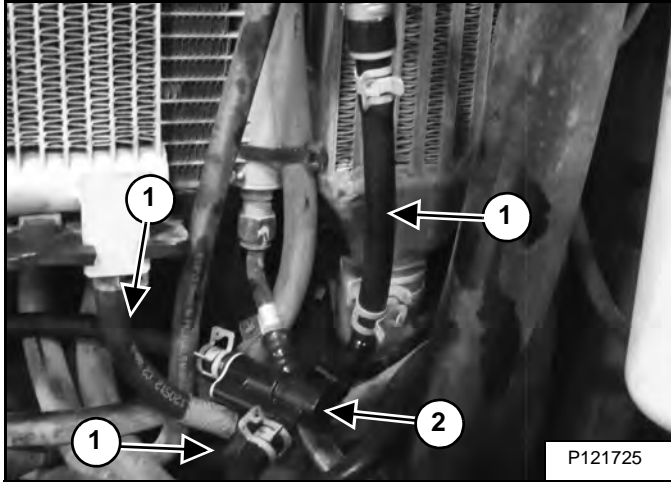

Remove the hoses (Item 1) and remove the valve (Item 2) [Figure 60-60-27].

### Fuel Injector Removal And Installation

Figure 60-60-28

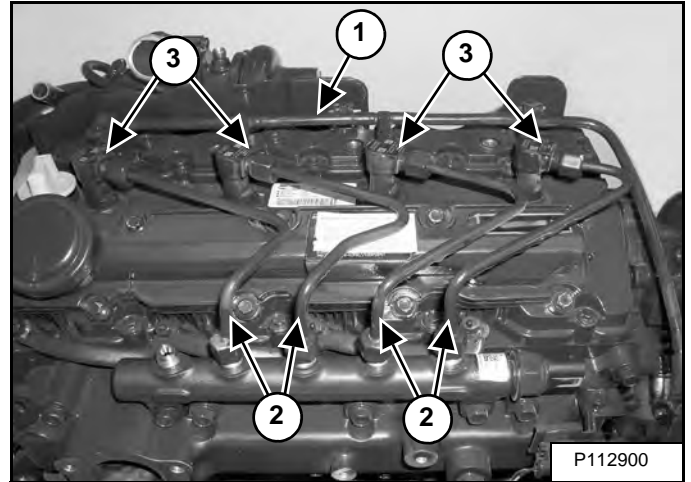

Remove the fuel return line (Item 1). Remove the high pressure fuel lines (Item 2) [Figure 60-60-28].

**Installation:** Tighten the high pressure fuel lines to 29,4 N•m (21.7 ft-lb) torque.

**NOTE:** Both the high pressure fuel lines and return fuel line are a one time use line. Replace the fuel lines with new fuel lines after removal.

Disconnect the wire harness (Item 3) [Figure 60-60-28] from the fuel injectors.

Figure 60-60-29

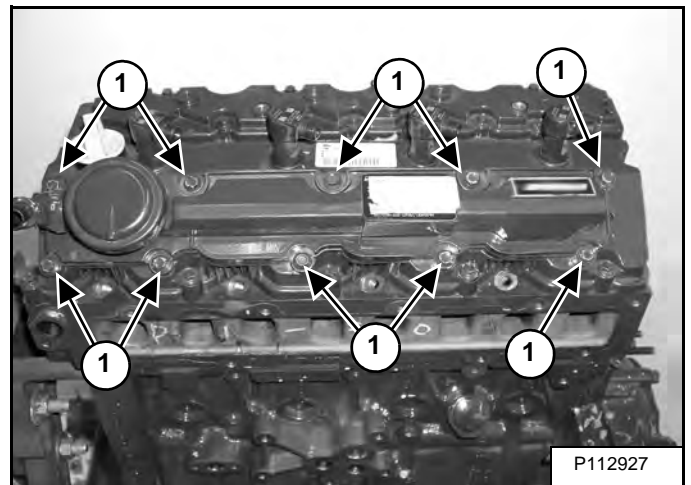

Remove the bolts (Item 1) [Figure 60-60-29] and remove the cylinder head cover.

**Installation:** Tighten the bolts to 7,8 N•m (5.8 ft-lb) torque.

## CYLINDER HEAD (CONT'D)

### Cylinder Head Removal And Installation (Cont'd)

Figure 60-70-21

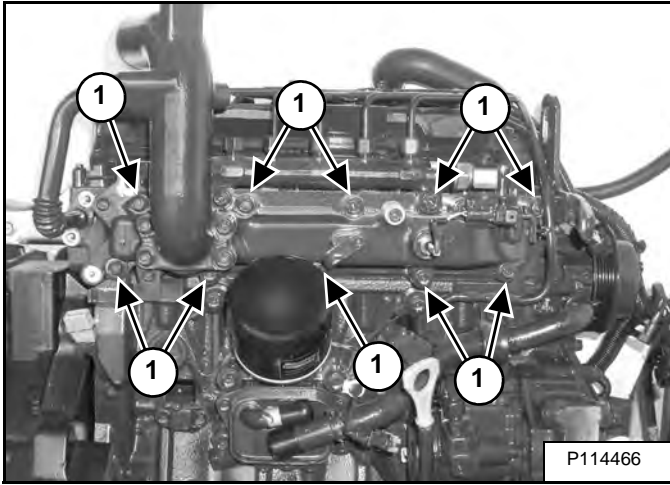

Remove the bolts, intake manifold (Item 1) [Figure 60-70-21] and gaskets.

**Installation:** Tighten the bolts to 22 N•m (16 ft-lb) torque.

Figure 60-70-22

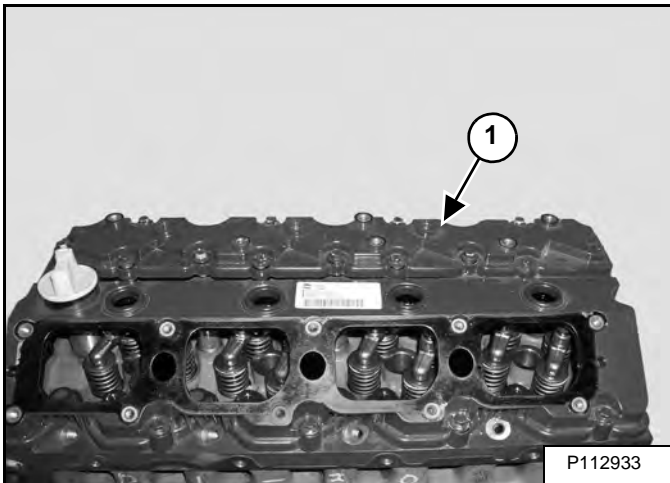

Loosen the bolts and remove the cylinder head cover (Item 1) [Figure 60-70-22].

**Installation:** Tighten the bolts to 7,8 N•m (5.8 ft-lb) torque.

Figure 60-70-23

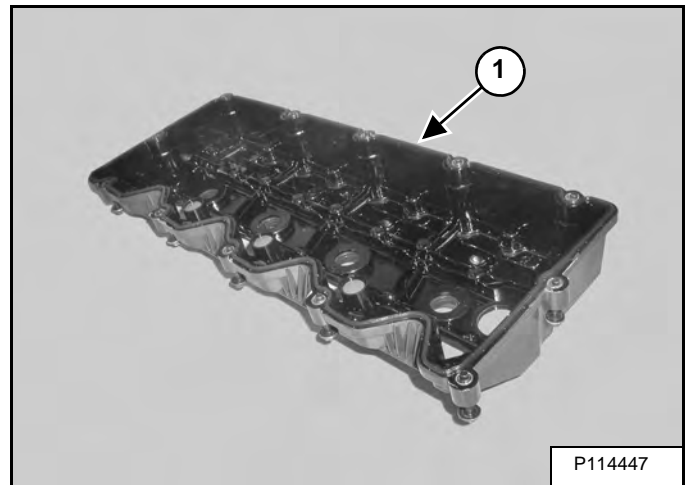

Remove the seal (Item 1) [Figure 60-70-23] from the cover.

Figure 60-70-24

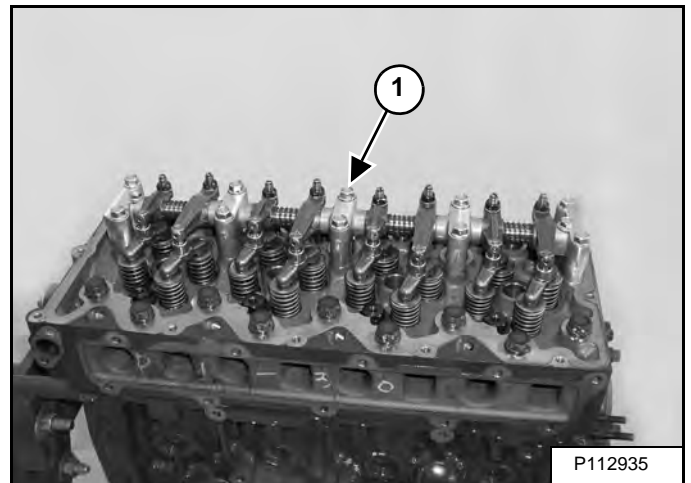

Remove the bolts (Item 1) [Figure 60-70-24] and remove the rocker arm assembly.

**Installation:** Tighten the bolts to 22 N•m (16 ft-lb) torque.

## CRANKSHAFT AND PISTONS

### Piston And Connecting Rod Removal And Installation

Remove the cylinder head. (See Cylinder Head Removal And Installation on Page 60-70-5.)

Remove the top edge from the cylinder bore with a ridge reamer.

Remove the oil pan and oil pump strainer. (See Oil Pan Removal And Installation on Page 60-50-2.)

Figure 60-80-1

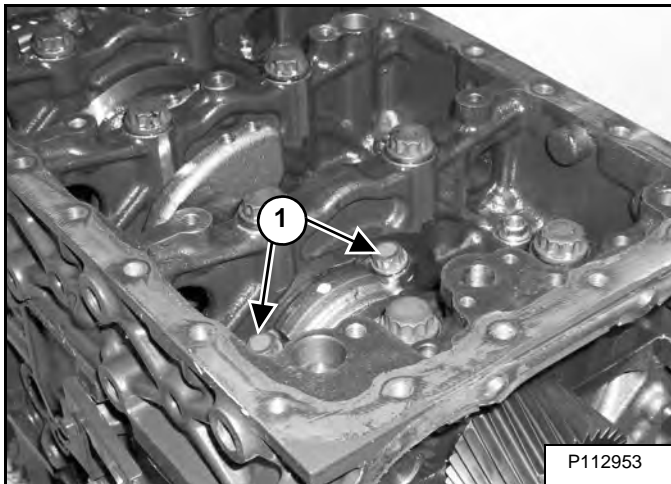

Remove the connecting rod bolts (Item 1) [Figure 60-80-3].

**Installation:** Tighten the bolts to an initial torque of 19,6 N•m (14.5 ft-lb). Tighten the bolts an additional 90°.

**NOTE:** The rod bolts are a one time use bolt. Use new bolts when installing the connecting rods.

Figure 60-80-2

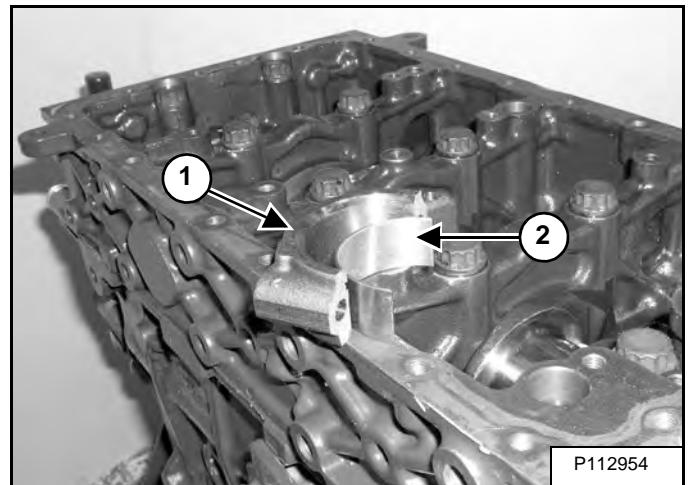

Remove the cap (Item 1) and bearing (Item 2) [Figure 60-80-2].

Figure 60-80-3

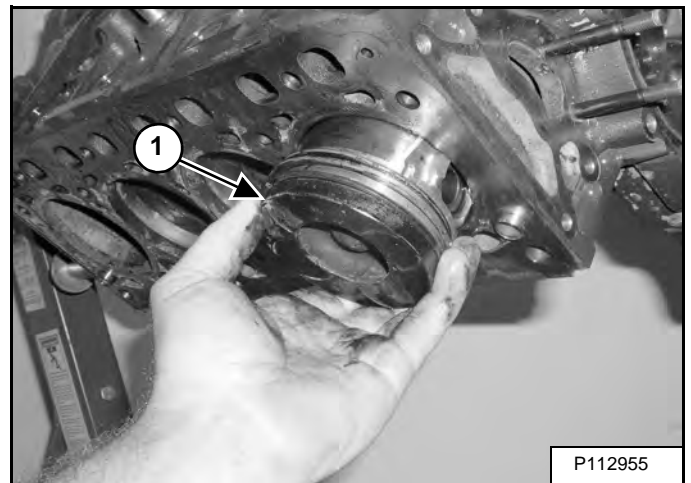

Remove the piston / connecting rod (Item 1) [Figure 60-80-3] from the cylinder block.

**NOTE:** Install the piston / connecting rod assembly in to the bore it was removed from.

Repeat the procedure to remove the remaining piston / connecting rod assemblies.

## CRANKSHAFT AND PISTONS (CONT'D)

### Engine Component Class (Cont'd)

Figure 60-80-34

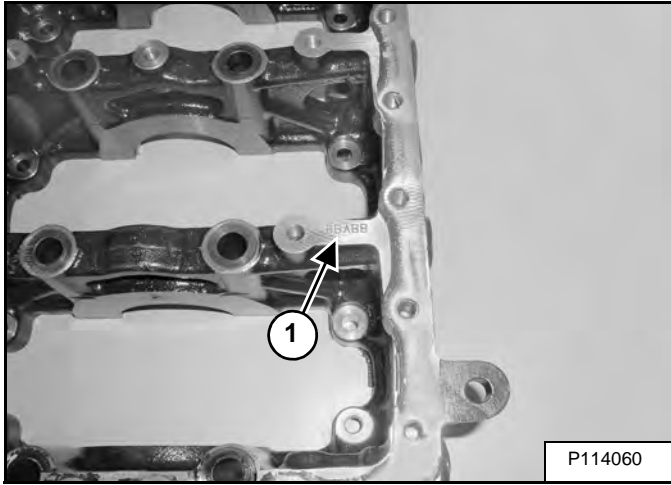

The cylinder block bearing bore class (Item 1) [Figure 60-80-34] is engraved on the flange of the crankcase.

Cylinder Block Main Journal Diameter	
Class A	62,000 - 62,007 mm (2.4409 - 2.4412 in)
Class B	62,007 - 62,014 mm (2.4412 - 2.4415 in)
Class C	62,014 - 62,021 mm (2.4415 - 2.4418 in)

When replacing crankshaft bearings, use the chart below.

Cylinder Block Main Journal Diameter	Crankshaft Main Journal Diameter		
	Class A	Class B	Class C
Class A	Yellow Bearing	Blue Bearing	Blue Bearing
Class B	Yellow Bearing	Yellow Bearing	Blue Bearing
Class C	Red Bearing	Red Bearing	Yellow Bearing

## TURBOCHARGER

### Description

The turbocharger is placed between the exhaust and intake manifolds. It is driven by hot exhaust gases and supplies air at more than atmospheric pressure to the intake. It is lubricated by oil from the main galley. The location of the turbo is between the engine and the blower housing.

**Figure 60-110-1**

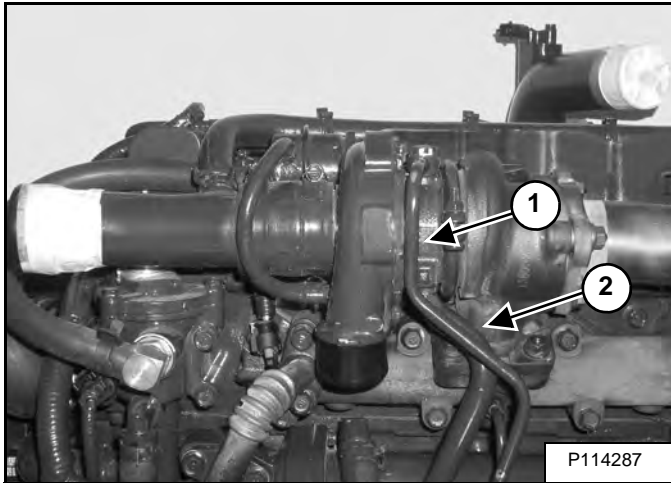

The oil is delivered to the turbocharger through a tubeline (Item 1) and returns to the engine block through a drain line (Item 2) [Figure 60-110-1].

The turbocharger internal components are not serviceable.

## EXHAUST GAS RECIRCULATION (EGR) SYSTEM (CONT'D)

### Removal And Installation (Cont'd)

Figure 60-130-8

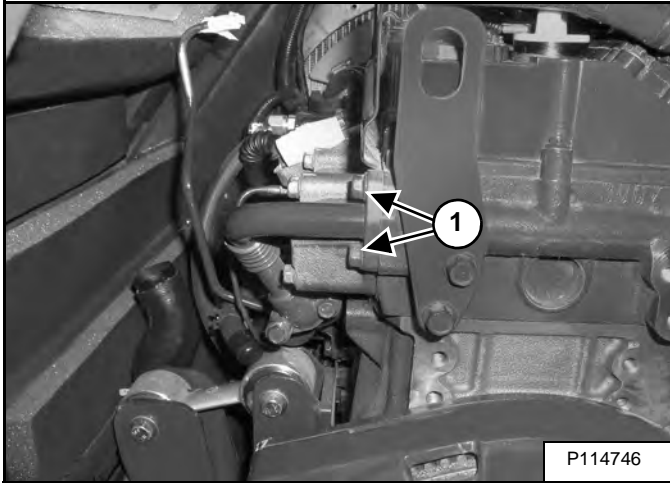
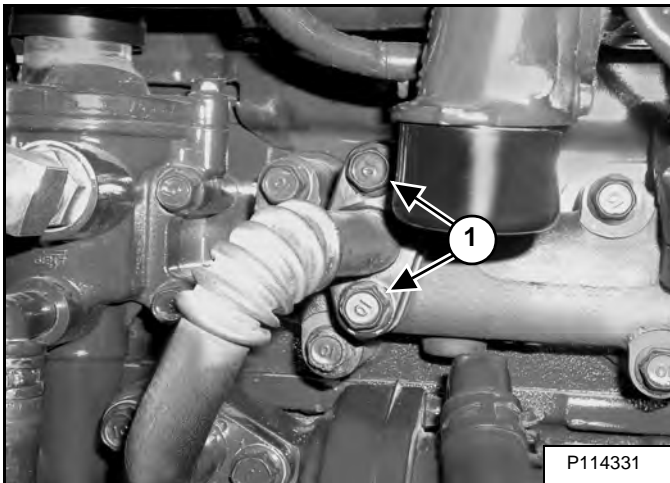

Figure 60-130-9



Remove the coolant tube bolts (Item 1) [Figure 60-130-8] and [Figure 60-130-9].

**Installation:** Tighten bolts to 22 N•m (16 ft-lb) torque.

Figure 60-130-10

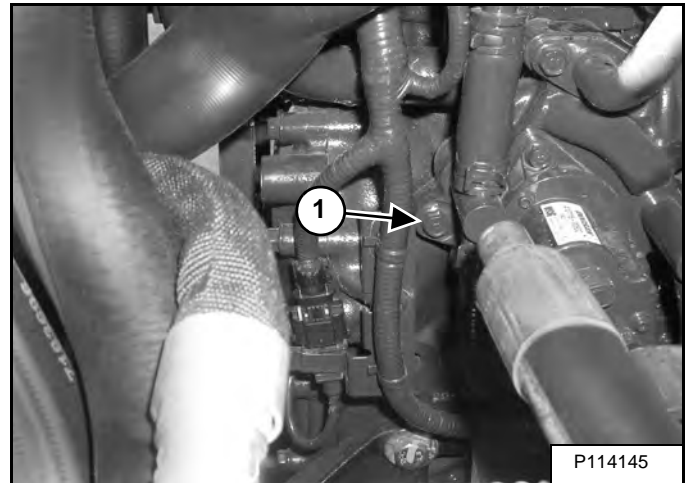
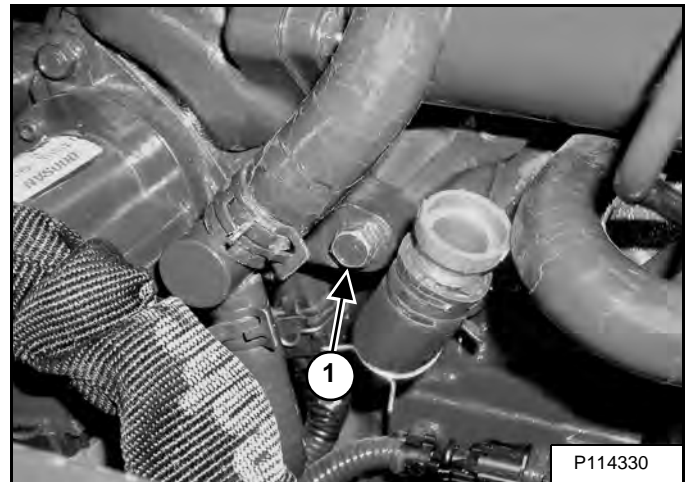

Figure 60-130-11



Remove the bolts (Item 1) [Figure 60-130-10] and [Figure 60-130-11].

**Installation:** Tighten the bolts to 22 N•m (16 ft-lb).

Remove the EGR assembly.

## AIR CONDITIONING SYSTEM FLOW (CONT'D)

### Components (Cont'd)

Figure 70-10-8

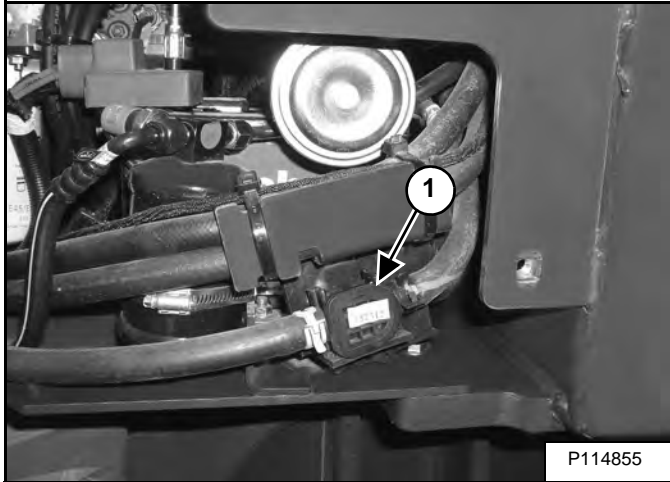

**Heater Valve:** The heater valve (Item 1) [Figure 70-10-8] is used to control the amount of engine coolant that flows to the heater coil.

The heater valve is located in front of the battery.

Figure 70-10-9

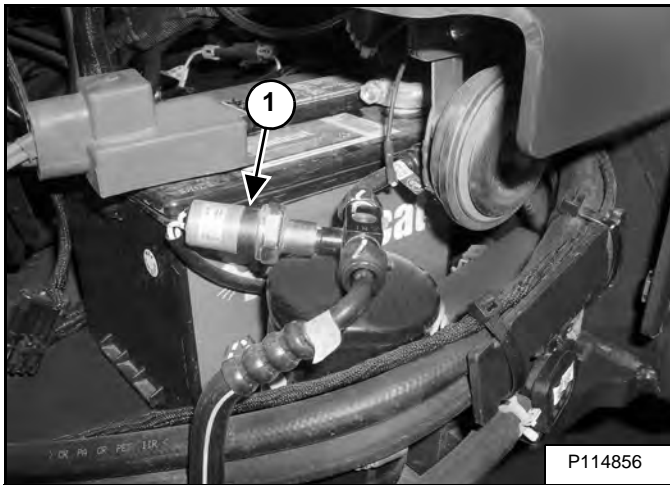

**High Pressure Switch:** The high pressure switch (Item 1) [Figure 70-10-9] will disengage the compressor clutch at high pressure readings over 2689 - 2827 kPa (26,9 - 28,3 bar) (390 - 410 psi) on the high side. The clutch will engage when the pressure is at 2103 - 2379 kPa (21 - 23,8 bar) (305 - 345 psi).

Figure 70-10-10

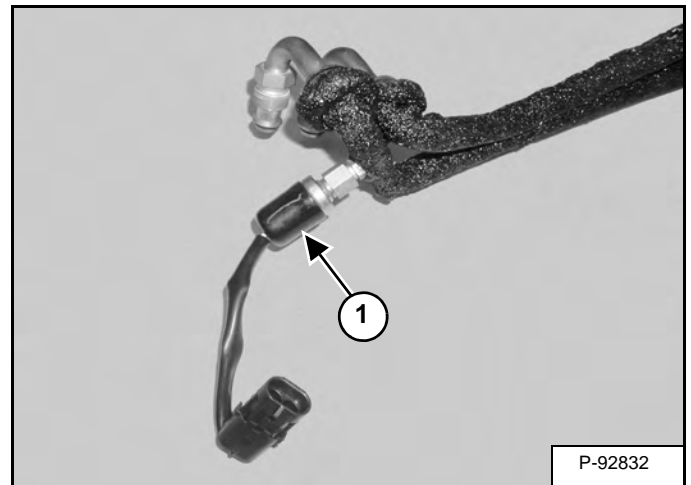

**Low Pressure Switch:** The low pressure switch (Item 1) [Figure 70-10-10] will disengage the compressor clutch at low pressure readings below 34 - 76 kPa (0,34 - 0,76 bar) (5 - 11 psi) on the low side. The clutch will engage when the pressure is at 117 - 186 kPa (1,2 - 1,9 bar) (17 - 27 psi).

Figure 70-10-11

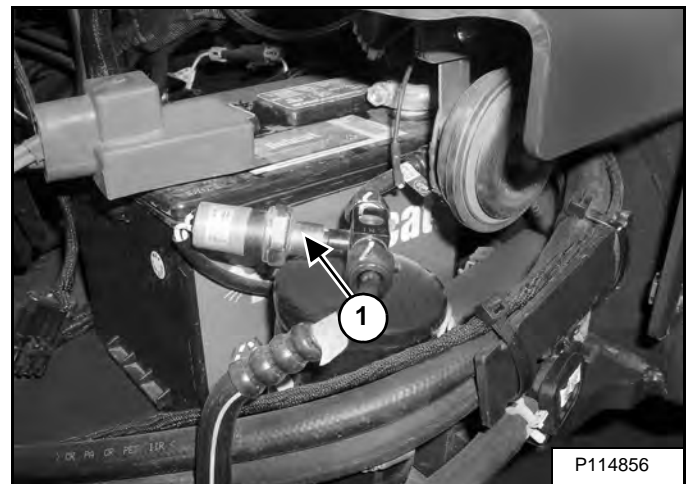

**High Pressure Switch / Low Pressure Switch:** The high pressure / low pressure switch (Item 1) [Figure 70-10-11] will engage the compressor between 186,2 - 241,3 kPa (1,86 - 2,41 bar) (27 - 35 psi) and 1901 - 2303 kPa (19 - 23 bar) (276 - 334 psi). The switch will disengage the compressor at pressure below 179,3 - 220,6 kPa (1,79 - 2,21 bar) (26 - 32 psi) and above 2503 - 2903 kPa (25 - 29 bar) (363 - 421 psi).

## TROUBLESHOOTING (CONT'D)

### Temperature / Pressure Chart

TEMP F	PSIG	TEMP F	PSIG
16	15.69	93	110.20
18	17.04	94	112.10
20	18.43	95	114.10
22	19.87	100	124.30
24	21.35	102	128.50
26	22.88	104	132.90
28	24.47	106	137.30
30	26.10	108	141.9
32	27.79	110	146.50
34	29.52	112	151.30
36	31.32	114	156.10
38	33.17	116	161.10
40	35.07	118	166.10
42	37.03	120	171.30
44	39.05	122	176.60
45	40.09	124	182.00
50	45.48	126	187.50
55	51.27	128	193.10
60	57.47	130	198.90
65	64.10	135	213.70
70	71.19	140	229.40
75	78.75	145	245.80
80	86.80	150	263.00
85	95.40	155	281.10
90	104.40	160	300.10
91	106.30	165	320.10
92	108.20	170	340.80

#### *Evaporator*

Pressures represent gas temperatures inside the coil, not the coil surface. For an estimate of the temperature of the air coming off the coil add -13 - -12°C (8 - 10°F) to the temperature on the chart.

#### *Condenser*

Temperatures are not ambient temperatures but condensing temperatures. Add 4°C (40°F) to the ambient temperature to get the condensing temperature and then refer to the pressure chart to see appropriate pressure for ambient temperature.

Example: Ambient Temperature = 90°F

$$\begin{aligned} &90^{\circ}\text{F} \\ &+ 40^{\circ}\text{F} \\ &130^{\circ}\text{F condenser temperature} = 200 \text{ psig} \end{aligned}$$

Conditions and pressures will vary from system to system.

## COMPRESSOR

### Removal And Installation

Remove the counterweight. (See Removal And Installation on Page 40-90-1.)

Remove the compressor belt. (See Air Conditioning Compressor Belt Replacement on Page 70-20-2.)

Evacuate the A/C system. (See Reclamation And Charging With Recovery / Charging Unit on Page 70-40-3.)

Figure 70-50-1

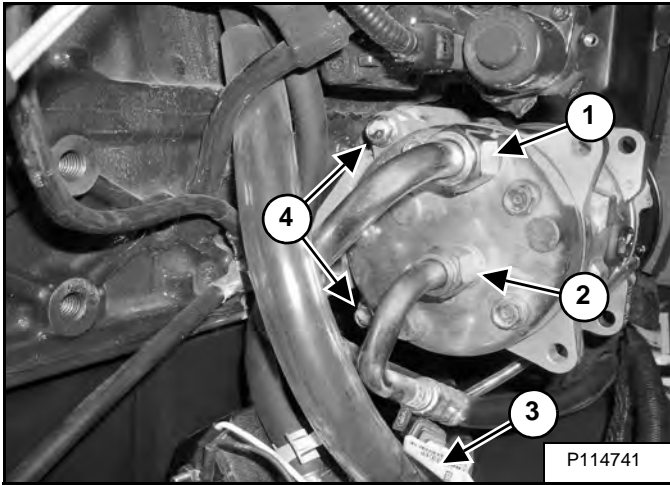

Remove the hose (Item 1) and (Item 2) [Figure 70-50-1].

**Installation:** Tighten the hose (Item 1) to 28 - 37 N•m (21 - 27 ft-lb) torque. Tighten the hose (Item 2) [Figure 70-50-1] to 20 - 27 N•m (15 - 20 ft-lb) torque.

## WARNING

In the event of a leak, wear safety goggles. Escaping refrigerant can cause severe injuries to eyes. In contact with a flame, R-134a refrigerant gives a toxic gas.

W-2371-0611

Disconnect the wire harness (Item 3) [Figure 70-50-1].

Remove the bolts (Item 4) [Figure 70-50-1].

Figure 70-50-2

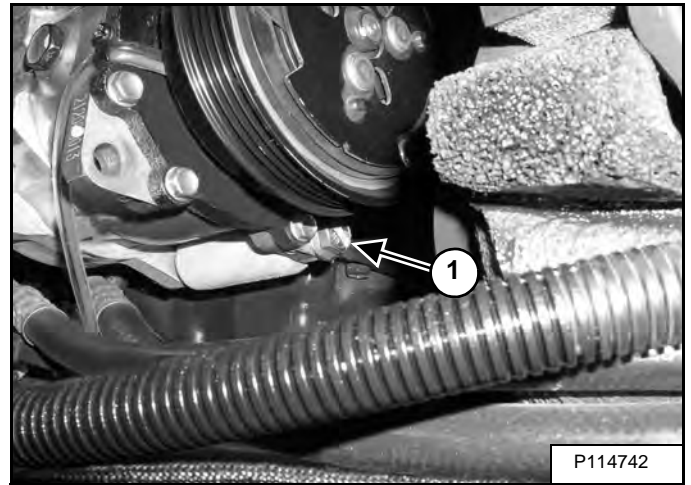

Remove the bolt (Item 1) [Figure 70-50-2].

Figure 70-50-3

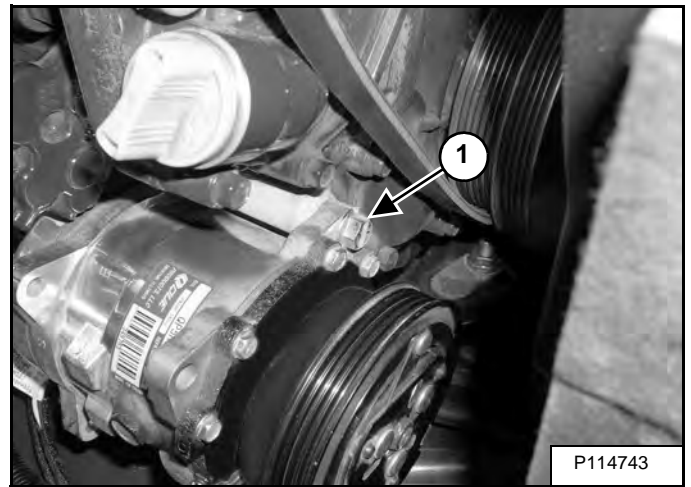

Remove the bolt (Item 1) [Figure 70-50-3].

Remove the compressor.

The compressor is not serviceable and must be replaced as an assembly.

## THERMOSTAT

### Description

The Electronic De-icing Thermostat (EDT) is a micro controller based module that measures evaporator coil temperature and cycles the compressor clutch to maintain a constant evaporator pressure. Onboard circuit protection and diagnostics are also built into the module.

**NOTE: The EDT has a six second delay before startup to protect the compressor clutch.**

The EDT will turn the clutch on when the evaporator coil temperature is above 2°C (35.6°F). If the EDT does not detect any malfunction, it will continue to operate and the status LED will be lit continuously. When the evaporator temperature is below -2°C (28.4°F), the EDT will turn off the clutch and status LED.

**Figure 70-90-1**

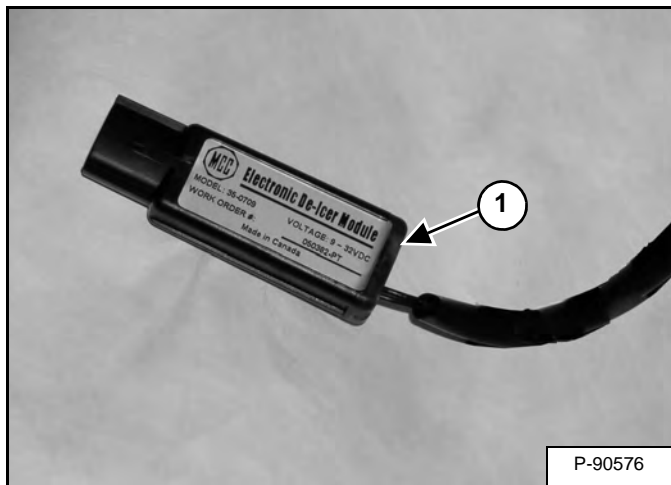

When the EDT detects an open or short from the temperature sensor, the status LED (Item 1) [Figure 70-90-1] will blink once per second and the output signal to the clutch will be turned off. The status LED will flash two times per second when EDT detects an open circuit (current draw less than 200 mA), short circuit or over current (current draw greater than 7A) from the clutch output. The status LED will flash three times per second when the compressor clutch is shorted to ground.

**NOTE: The EDT will attempt to restart every 20 seconds until the fault is repaired.**

**The EDT has the following protection built in:**

1. Over temperature
2. Over current from clutch output
3. Voltage (Above and below operational limits or reverse voltage)
4. Short circuit protection (Output shorted to ground)
5. Temperature sensor open and short detection

MALFUNCTION	DETECTION INTERVAL	STATUS LED
Temperature sensor	Continuous	1x per second
Temperature sensor open and short detection	At A/C startup	2x per second
Compressor clutch short to battery	Continuous	3x per second

## BLOWER FAN

### Removal And Installation

Figure 70-130-1



Mark and remove the wire connectors from the motor [Figure 70-130-1].

Figure 70-130-2

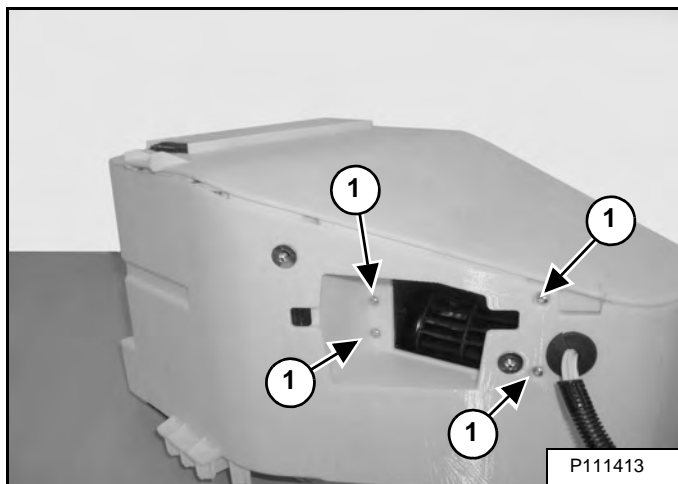

Remove the two bolts (Item 1) [Figure 70-130-2].

Remove the motor.

# EXCAVATOR SPECIFICATIONS (CONT'D)

## Machine Dimensions (Long Arm)

- Where applicable, specification conform to SAE or ISO standards and are subject to change without notice.

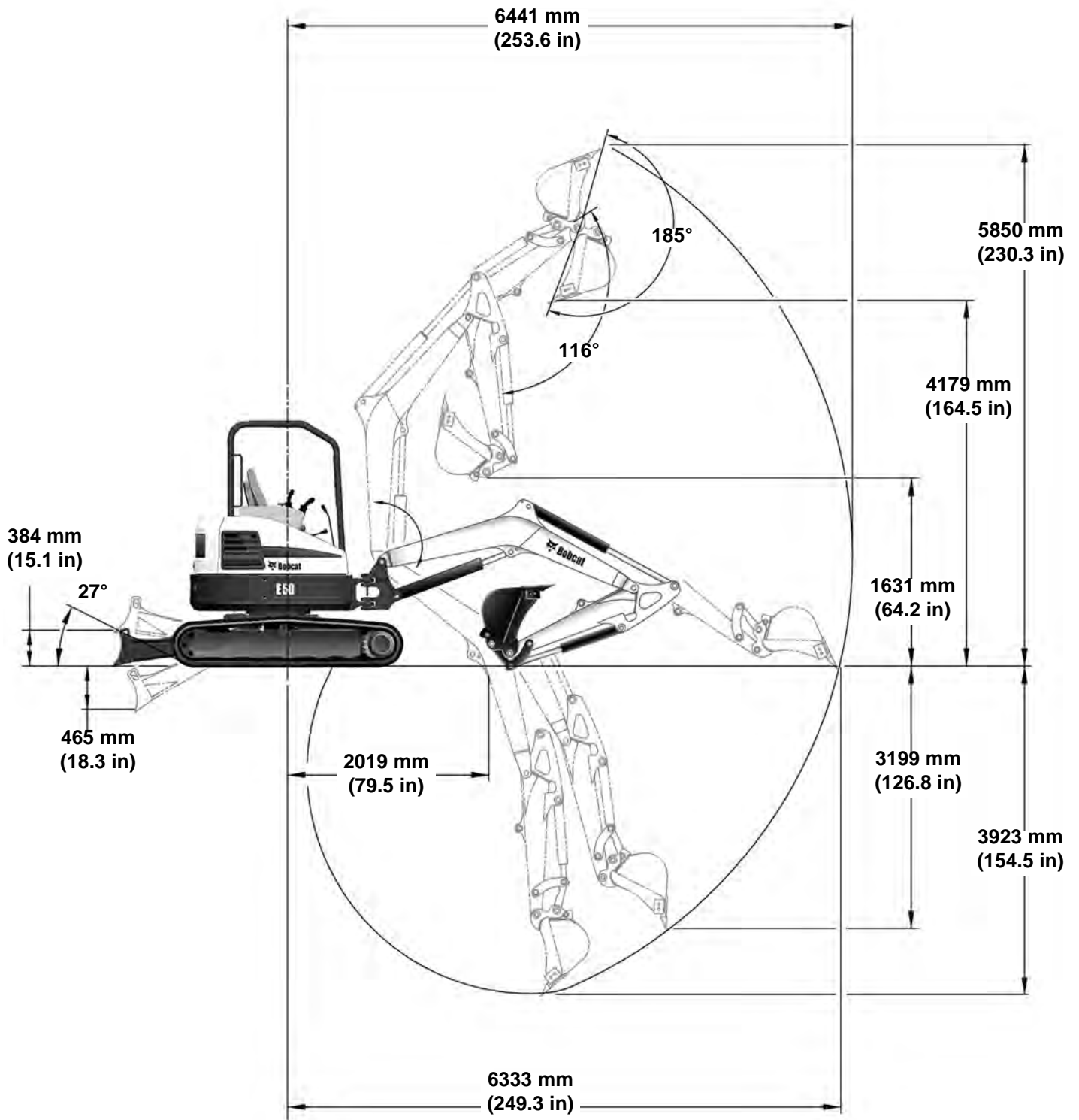

NA5067

## TECHNICAL SERVICE GUIDE SPECIFICATIONS

### Engine

Engine Oil Pressure at Low Idle	147 kPa (1,47 bar) (21.3 psi)
Engine Oil Pressure at High Idle	392 - 539 kPa (3,92 - 5,39 bar) (57 - 78 psi)
Location of Number 1 Cylinder	Closest to water pump
Crankshaft Rotation (Facing Crankshaft Pulley)	Clockwise
Valve Clearance (Cold) Intake	0,4 mm (0.016 in)
Valve Clearance (Cold) Exhaust	0,45 mm (0.018 in)

**NOTE:** For additional engine specifications, (See Specifications on Page 60-10-2.)

### Engine Torques

Fuel Injection Tubeline Nuts	29,4 N•m (21.7 ft-lb)
Fuel Injector Retaining Bolt	39 - 46 N•m (29 - 34 ft-lb)
Glow Plugs	8,8 - 11,8 N•m (6.5 - 8.7 ft-lb)
Valve Cover Bolts	7,8 N•m (5.8 ft-lb)
Head Bolts	Initial torque 39 N•m (29 ft-lb) + 90° + 90° + 90°

**NOTE:** For additional engine torques, (See Engine Removal And Installation on Page 60-10-14.)

### Cooling System

Coolant Type and Mix	47% Water and 53% Propylene Glycol
Radiator Cap Pressure	89 kPa (0,9 bar) (13 psi)
Thermostat	Fully Open at 97°C (207°F)

**NOTE:** For additional cooling system information, (See ENGINE COOLING SYSTEM on Page 60-40-1.)

### Excavator Torques

Drive Motor To Frame Bolt	160 - 180 N•m (118 - 133 ft-lb)
Sprocket To Drive Motor	108 N•m (80 ft-lb)
Swing Bearing To Frame Bolt	105 - 115 N•m (78 - 85 ft-lb)
Swing Bearing To Upperstructure Bolt	105 - 115 N•m (78 - 85 ft-lb)
Swing Motor Drive Carrier	255 - 285 N•m (188 - 210 ft-lb)
Swing Motor Mounting Bolts	87 - 119 N•m (64 - 87 ft-lb)

## HYDRAULIC FLUID SPECIFICATIONS

### Specifications

Use only Bobcat hydraulic fluid.

DO NOT use automatic transmission fluids in the excavator or permanent damage to the hydraulic system will result.

Bobcat hydraulic fluid is available in:

- 9,5 L (2.5 Gal) qty 2 (P/N 6903117)
- 18,9 L (5 Gal) (P/N 6903118)
- 208 L (55 Gal) (P/N 6903119)



#### AVOID INJURY OR DEATH

Diesel fuel or hydraulic fluid under pressure can penetrate skin or eyes, causing serious injury or death. Fluid leaks under pressure may not be visible. Use a piece of cardboard or wood to find leaks. Do not use your bare hand. Wear safety goggles. If fluid enters skin or eyes, get immediate medical attention from a physician familiar with this injury.

W-2072-0807

When temperatures below  $-18^{\circ}\text{C}$  ( $0^{\circ}\text{F}$ ) are common, the excavator must be kept in a warm building. Extra warm-up time must be used each time the excavator is started during cold temperature conditions. Cold fluid will not flow easily and it makes action of the hydraulic function slower. Loss of fluid flow to the hydraulic system (Indicated by hydraulic temp / pressure lights on) can cause system damage in less than 60 seconds.



During cold weather ( $0^{\circ}\text{C}$  [ $32^{\circ}\text{F}$ ] and below), do not operate machine until the engine has run for at least 5 minutes at less than half throttle. This warm-up period is necessary for foot pedal operation and safe stopping. Do not operate controls during warm-up period.

When temperatures are below  $-30^{\circ}\text{C}$  ( $-20^{\circ}\text{F}$ ), the hydrostatic oil must be heated or kept warm. The hydrostatic system will not get enough oil at low temperatures. Park the machine in an area where the temperature will be above  $-18^{\circ}\text{C}$  ( $0^{\circ}\text{F}$ ) if possible.

W-2027-0311

CLICK HERE TO **DOWNLOAD** THE COMPLETE MANUAL

- Thank you very much for reading the preview of the manual.
- You can download the complete manual from: [www.heydownloads.com](http://www.heydownloads.com) by clicking the link below



- Please note: If there is no response to CLICKING the link, please download this PDF first and then click on it.

CLICK HERE TO **DOWNLOAD** THE COMPLETE MANUAL