



Bobcat®

Service Manual



E17

Compact Excavator

S/N B27H11001 & Above
S/N B4PJ11001 & Above
S/N B4PR11001 & Above



CLICK HERE TO **DOWNLOAD** THE COMPLETE MANUAL

- Thank you very much for reading the preview of the manual.
- You can download the complete manual from: www.heydownloads.com by clicking the link below



- Please note: If there is no response to CLICKING the link, please download this PDF first and then click on it.

CLICK HERE TO **DOWNLOAD** THE COMPLETE MANUAL

SAFETY INSTRUCTIONS



Safety Alert Symbol

This symbol with a warning statement means: "Warning, be alert! Your safety is involved!" Carefully read the message that follows.



WARNING

AVOID INJURY OR DEATH

Instructions are necessary before operating or servicing machine. Read and understand the Operation & Maintenance Manual, Operator's Handbook and signs (decals) on machine. Follow warnings and instructions in the manuals when making repairs, adjustments or servicing. Check for correct function after adjustments, repairs or service. Untrained operators and failure to follow instructions can cause injury or death.

W-2003-0807

IMPORTANT

This notice identifies procedures which must be followed to avoid damage to the machine.

I-2019-0284



DANGER

The signal word DANGER on the machine and in the manuals indicates a hazardous situation which, if not avoided, will result in death or serious injury.

D-1002-1107



WARNING

The signal word WARNING on the machine and in the manuals indicates a potentially hazardous situation which, if not avoided, could result in death or serious injury.

W-2044-1107

The following publications provide information on the safe use and maintenance of the Bobcat machine and attachments:

- The Delivery Report is used to assure that complete instructions have been given to the new owner and that the machine is in safe operating condition.
- The Operation & Maintenance Manual delivered with the machine or attachment contains operating information as well as routine maintenance and service procedures. It is a part of the machine and can be stored in a container provided on the machine. Replacement Operation & Maintenance Manuals can be ordered from your Bobcat dealer.
- Machine signs (decals) instruct on the safe operation and care of your Bobcat machine or attachment. The signs and their locations are shown in the Operation & Maintenance Manual. Replacement signs are available from your Bobcat dealer.
- An Operator's Handbook fastened to the operator cab. It's brief instructions are convenient to the operator. The handbook is available from your dealer in an English edition or one of many other languages. See your Bobcat dealer for more information on translated versions.
- The AEM Safety Manual delivered with the machine gives general safety information.
- The Service Manual and Parts Manual are available from your dealer for use by mechanics to do shop-type service and repair work.
- The Compact Excavator Operator Training Course is available through your local dealer or at **Bobcat.com/training** or **Bobcat.com**. This course is intended to provide rules and practices of correct operation of the Bobcat excavator. The course is available in English and Spanish versions.
- Service Safety Training Courses are available from your Bobcat dealer or at **Bobcat.com/training** or **Bobcat.com**. They provide information for safe and correct service procedures.
- The Bobcat compact excavator Safety Video is available from your Bobcat dealer or at **Bobcat.com/training** or **Bobcat.com**.

SI EXC-1016 SM

REMOTE START TOOL (SERVICE TOOL) KIT - 7217666	10-231-1
Description	10-231-1
Remote Start Tool (Service Tool) - 7022042	10-231-2
Excavator Service Tool Harness - 6689747	10-231-3
Computer Service Tool Harness - 6689746	10-231-4

OPERATOR CAB (ROPS / TOPS) (CONT'D)

Right Side Window

Opening The Right Front Window

Figure 10-30-11

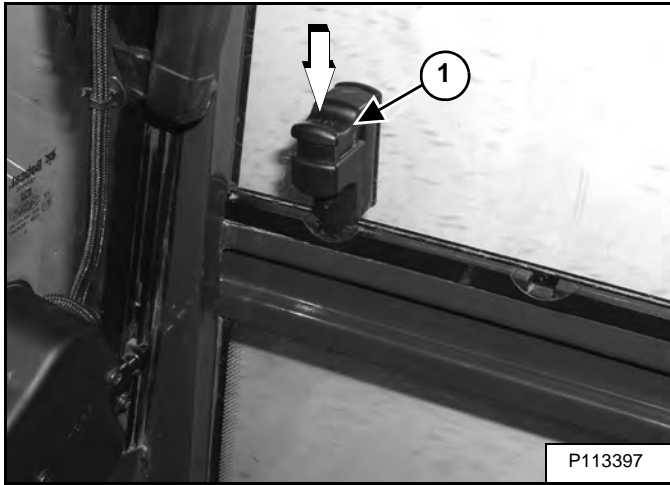

Press down on the latch (Item 1) [Figure 10-30-11] located at the front of the front window.

Figure 10-30-12

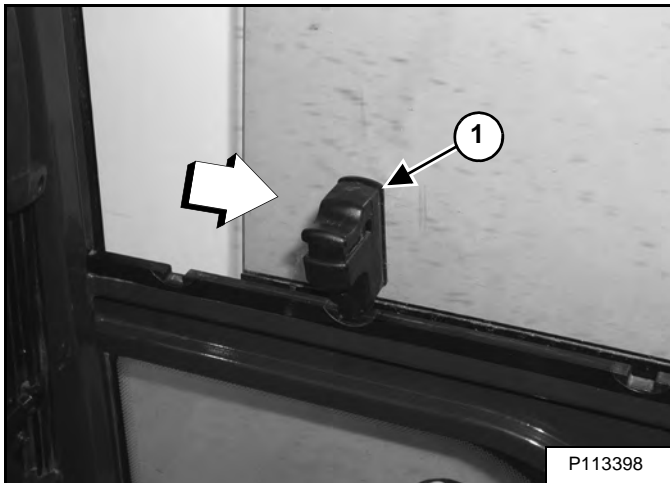

Pull the latch (Item 1) [Figure 10-30-12] backward to open the window until the desired stop. Release the latch and latch the window in place.

Closing The Right Front Window

Press down on the latch (Item 1) [Figure 10-30-11] and push the latch forward to close the window.

Heating And Ventilation Ducting

Figure 10-30-13

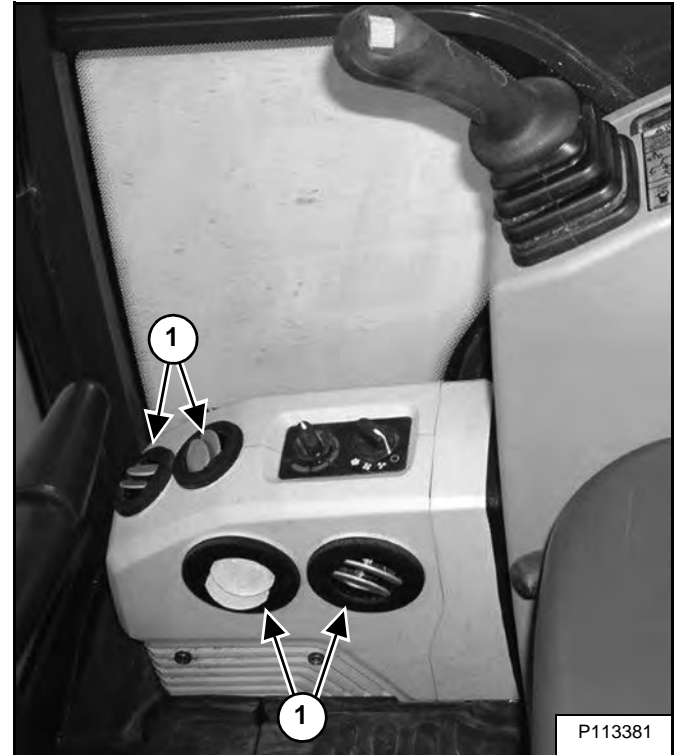

The heating and ventilation louvers (Item 1) [Figure 10-30-13] can be positioned as needed to direct the air flow to various areas in the cab.

AIR CLEANER SERVICE

See the service schedule for the correct service interval. (See Maintenance Intervals on Page 10-60-1.)

Daily Check

The air cleaner is located in the engine compartment. Open the tailgate to access the air cleaner for service.

Figure 10-70-1

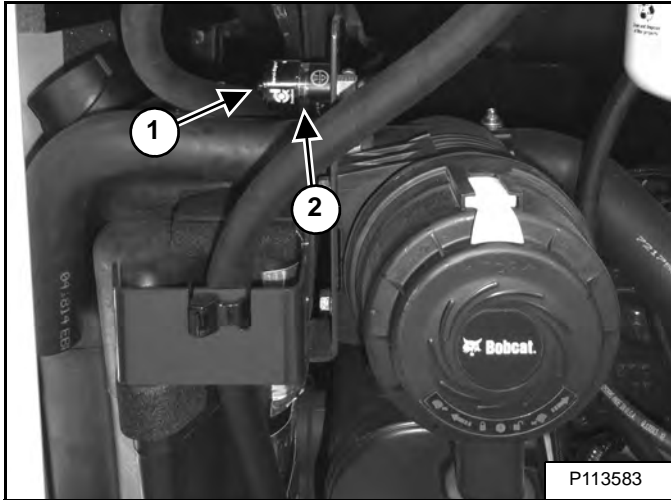

Check the condition indicator (Item 1). If the red ring (Item 2) [Figure 10-70-1] shows in the condition indicator, the filter needs to be replaced.

Replace the inner filter every third time the outer filter is replaced or as indicated.

Replacing The Filter Elements

Outer Filter

Figure 10-70-2

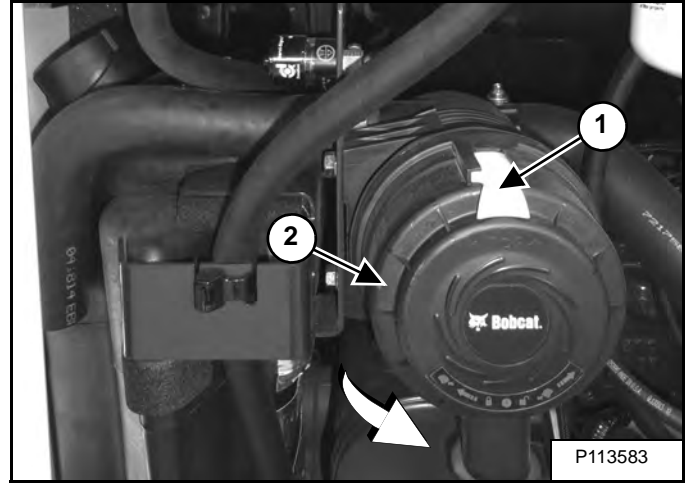

Pull out on the latch (Item 1). Rotate the cover counterclockwise and remove the dust cover (Item 2) [Figure 10-70-2].

Figure 10-70-3

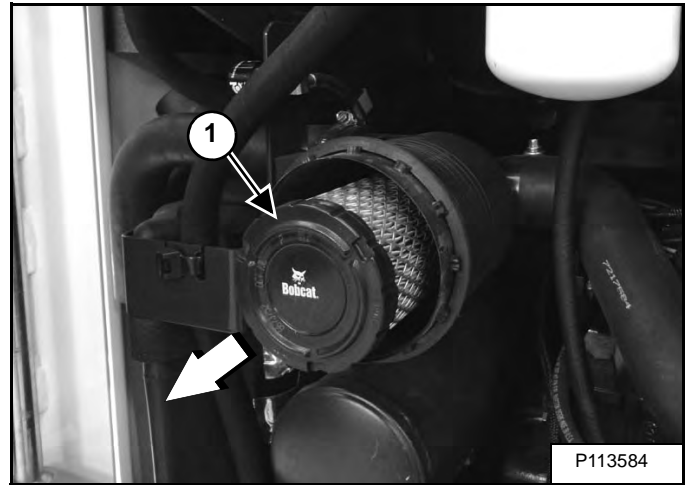

Slightly rotate the filter and pull the outer filter (Item 1) [Figure 10-70-3] from the air cleaner housing.

Check the housing for damage.

Clean the housing and the seal surface. DO NOT use compressed air.

Install a new filter.

FUEL SYSTEM (CONT'D)

Fuel Filter

Removing Water

Open the tailgate. (See Opening And Closing on Page 10-50-1.)

Figure 10-100-2

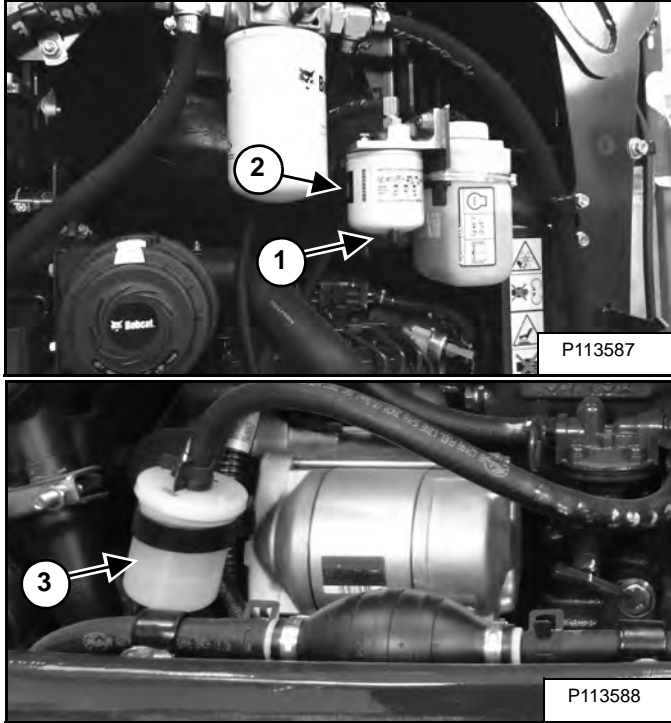

Loosen the drain (Item 1) [Figure 10-100-2] at the bottom of the filter to drain water from the filter into a container.

Inspect the fuel pre-filter (Item 3) [Figure 10-100-2] daily for moisture and contamination. Replace as necessary.

Clean up any spilled fuel.

Replacing Elements

Remove and replace the fuel pre-filter (Item 3) [Figure 10-100-2].

Remove the filter (Item 2) [Figure 10-100-2].

Clean the area around the filter housing. Put clean oil on the seal of the new filter. Install the fuel filter and hand tighten.

Remove the air from the fuel system. (See Removing Air From The Fuel System on Page 10-100-5.)

WARNING

AVOID INJURY OR DEATH

Diesel fuel or hydraulic fluid under pressure can penetrate skin or eyes, causing serious injury or death. Fluid leaks under pressure may not be visible. Use a piece of cardboard or wood to find leaks. Do not use your bare hand. Wear safety goggles. If fluid enters skin or eyes, get immediate medical attention from a physician familiar with this injury.

W-2072-0807

LUBRICATING THE EXCAVATOR

Lubrication Locations

Lubricate the excavator as specified in the SERVICE SCHEDULE for the best performance of the machine. (See SERVICE SCHEDULE on Page 10-60-1.)

Always use a good quality lithium based multipurpose grease when lubricating the machine. Apply the lubricant until extra grease shows.

Lubricate the following locations on the excavator **EVERY 8 - 10 HOURS**:

Figure 10-130-1

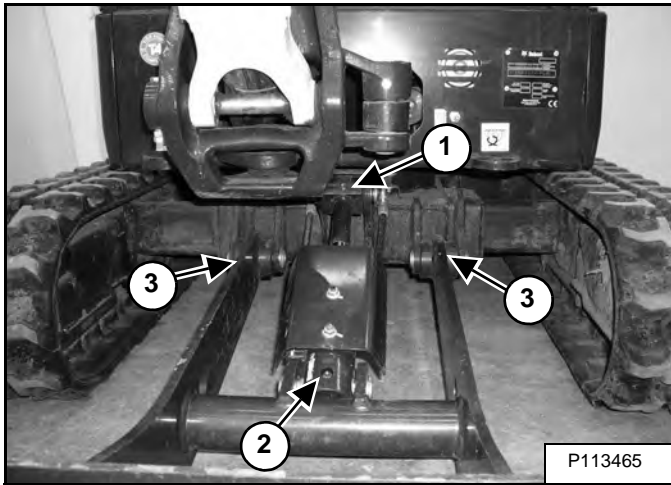

Ref Description (# of Fittings)

1. Blade Cylinder Rod End (1) [Figure 10-130-1]
2. Blade Cylinder Base End (1) [Figure 10-130-1]
3. Blade Pivots (2) [Figure 10-130-1]

Figure 10-130-2

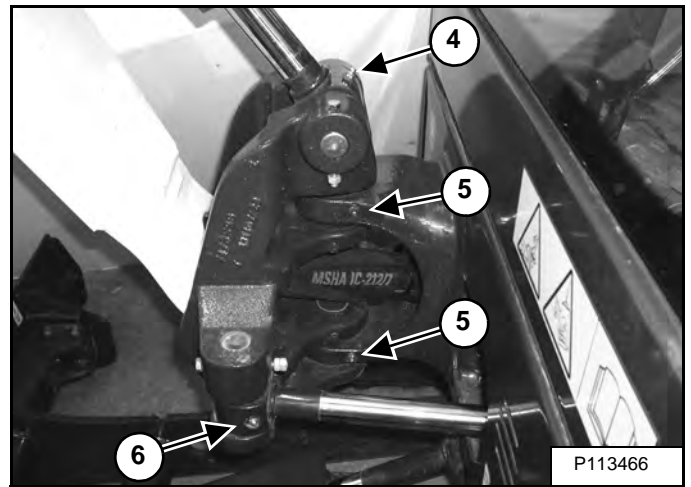

4. Boom Cylinder Rob End (1) [Figure 10-130-2]
5. Boom Swing Pivot (3) [Figure 10-130-2]
6. Boom Swing Cylinder Rod End (1) [Figure 10-130-2]

Figure 10-130-3

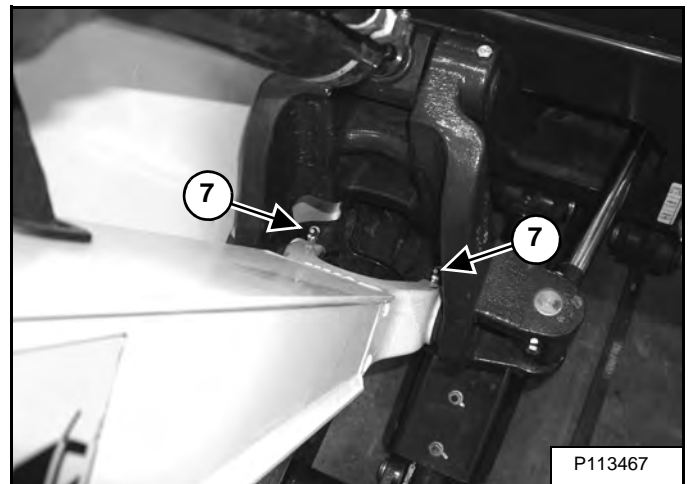

7. Boom Pivot (2) [Figure 10-130-3]

SEAT BELT

Inspection And Maintenance

WARNING

Failure to properly inspect and maintain the seat belt can cause lack of operator restraint resulting in serious injury or death.

W-2466-0703

Check the seat belt daily for correct function.

Inspect the seat belt system thoroughly yearly or more often if the machine is exposed to severe environmental conditions or applications.

The seat belt system should be repaired or replaced if it shows cuts, fraying, extreme or unusual wear, significant discolorations due to ultraviolet (UV) rays from the sun, dusty / dirty conditions, abrasion to the seat belt webbing, or damage to the buckle, latch plate, retractor (if equipped), or hardware.

Figure 10-170-1

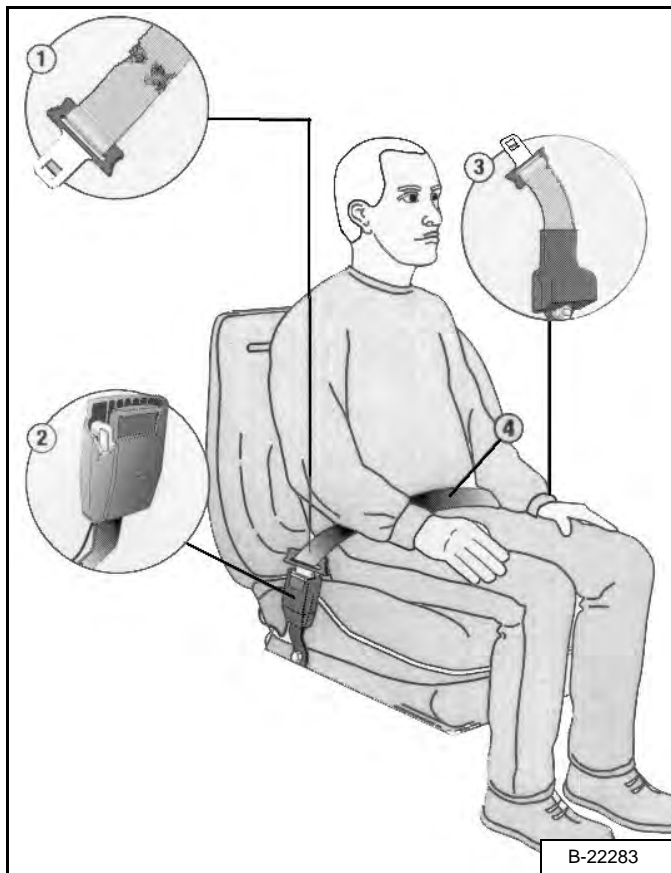

The items below are referenced in [Figure 10-170-1].

1. Check the seat belt webbing. If the system is equipped with a retractor, pull the webbing completely out and inspect the full length of the webbing. Look for cuts, wear, fraying, dirt and stiffness.
2. Check the buckle and latch for proper function. Make sure latch plate is not excessively worn, deformed or buckle is not damaged.
3. Check the retractor web storage device (if equipped) by extending the seat belt webbing to determine if it extends and retracts the webbing correctly.
4. Check webbing in areas exposed to ultraviolet (UV) rays from the sun or extreme dust or dirt. If the original color of the webbing in these areas is extremely faded and / or the webbing is packed with dirt, the webbing strength may have weakened.

EMERGENCY EXIT

The door, the rear window and the front window provide exits.

Side Or Rear Window

Figure 10-220-1

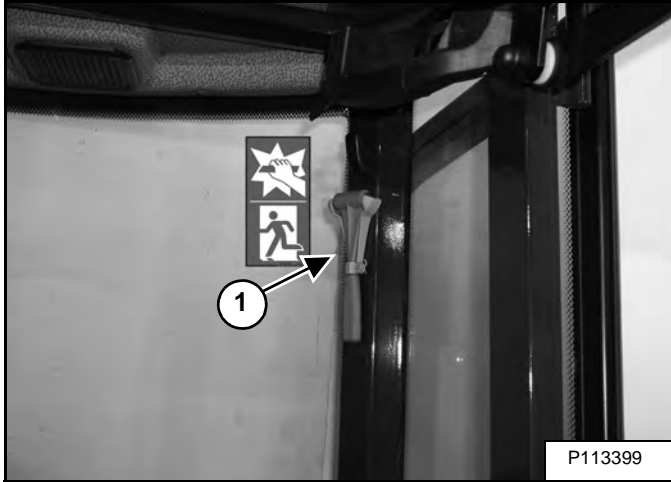

If emergency exit through the rear window is required, use the supplied hammer (Item 1) [Figure 10-220-1] located on the left rear side of the cab to break the window.

Figure 10-220-2

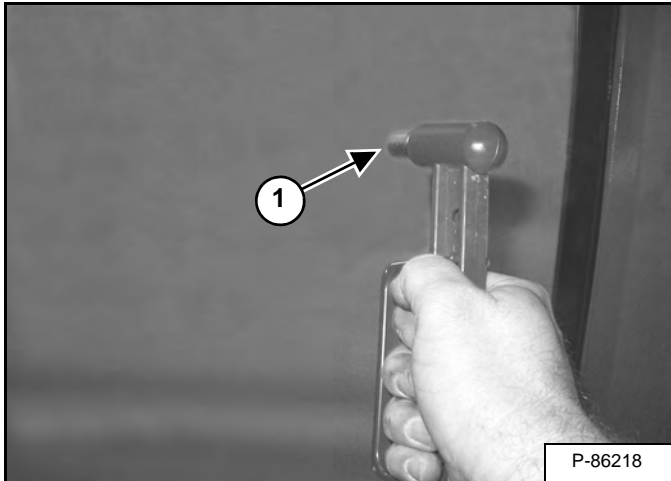

Remove the hammer from the storage position and strike the glass with the pointed end of the hammer [Figure 10-220-2].

Use the hammer to remove broken glass from the edge of the window before exiting.

Front Window

Figure 10-220-3



Open the front window and exit [Figure 10-220-3].

NOTE: If the excavator has a Special Applications Kit installed, the front window is NOT an emergency exit.

HYDRAULIC SYSTEM

HYDRAULIC SYSTEM INFORMATION	20-10-1
Glossary Of Hydraulic / Hydrostatic Symbols	20-10-1
Troubleshooting The Hydraulic Circuit	20-10-4
Troubleshooting The Cylinder Circuit	20-10-5
Troubleshooting The Swing (Upperstructure Slew) Circuit	20-10-6
Troubleshooting The Travel Circuit	20-10-7
CYLINDER (BOOM)	20-20-1
Testing	20-20-1
Removal And Installation	20-20-3
Parts Identification	20-20-5
Disassembly	20-20-6
Assembly	20-20-8
CYLINDER (ARM)	20-21-1
Testing	20-21-1
Removal And Installation	20-21-3
Parts Identification	20-21-5
Disassembly	20-21-6
Assembly	20-21-8
CYLINDER (BOOM SWING)	20-22-1
Testing	20-22-1
Removal And Installation	20-22-2
Parts Identification (Earlier Models)	20-22-4
Disassembly (Earlier Models)	20-22-5
Assembly (Earlier Models)	20-22-7
Parts Identification (Later Models)	20-22-10
Disassembly (Later Models)	20-22-11
Assembly (Later Models)	20-22-13
CYLINDER (BUCKET)	20-23-1
Testing	20-23-1
Removal And Installation	20-23-3
Parts Identification	20-23-4
Disassembly	20-23-5
Assembly	20-23-7
CYLINDER (BLADE)	20-24-1
Testing	20-24-1
Removal And Installation	20-24-2
Parts Identification (Earlier Models)	20-24-4
Disassembly (Earlier Models)	20-24-5
Assembly (Earlier Models)	20-24-7
Parts Identification (Later Models)	20-24-10
Disassembly (Later Models)	20-24-11
Assembly (Later Models)	20-24-13

HYDRAULIC SYSTEM INFORMATION (CONT'D)

Troubleshooting The Hydraulic Circuit

PROBLEM	CAUSE	CORRECTION
No hydraulic operation at 1 or more circuits.	Hydraulic oil level low.	Refill with correct oil.
	Hydraulic pump drive coupling damaged.	Replace.
	Hydraulic pump defective.	Check, repair or replace.
	Main relief valve defective.	Readjust or replace.
Hydraulic power insufficient to 1 or more circuits.	Main relief valve pressure setting incorrect.	Readjust or replace.
Hydraulic speed too slow.	Hydraulic oil level or viscosity incorrect.	Refill or replace.
	Engine rpm reduced.	Readjust or replace.
	Control valve linkage defective.	Check, repair or replace
	Hydraulic pump volume low.	Check, repair or replace.
Oil temperature too high.	Oil cooler or radiator fins plugged.	Clean oil cooler external surface.
	Hydraulic oil level low.	Refill or replace.
	Non recommended hydraulic oil	Replace.
	Relief valve excessively activated.	Use proper operating procedures.
	1 or more relief valves not set correctly.	Test, readjust or replace.
	Extreme operating conditions. High ambient temperature (IE: enclosed structure).	
	Alternator belt loose.	Tighten alternator belt.

CYLINDER (BOOM) (CONT'D)

Disassembly

Clean the outside of the cylinder before disassembly.

Use the following tools to disassemble the cylinder:

MEL1074 - O-ring Seal Hook

MEL1075 - Adjustable Gland Nut Wrench

MEL1075-1 - Standard Pins

Hold the hydraulic cylinder over a drain pan and move the rod in and out slowly to remove the fluid from the cylinder.

Put the base end of the cylinder in a vise.

Figure 20-20-11

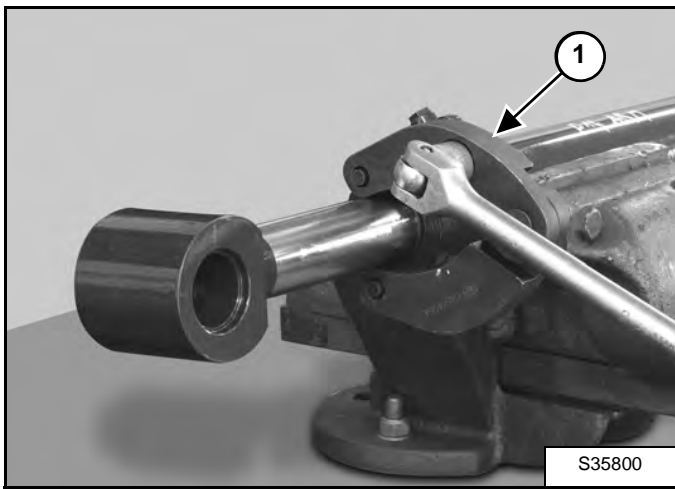

Use the Adjustable Gland Nut Wrench (Item 1) [Figure 20-20-11] to loosen the head.

Remove the head and the rod assembly from the cylinder. Put the rod end in a vise.

Figure 20-20-12

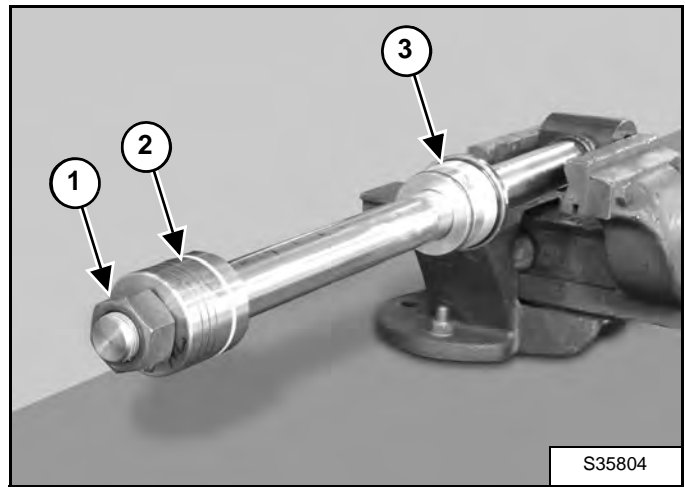

Remove the nut (Item 1), piston (Item 2) and head (Item 3) [Figure 20-20-12].

Figure 20-20-13

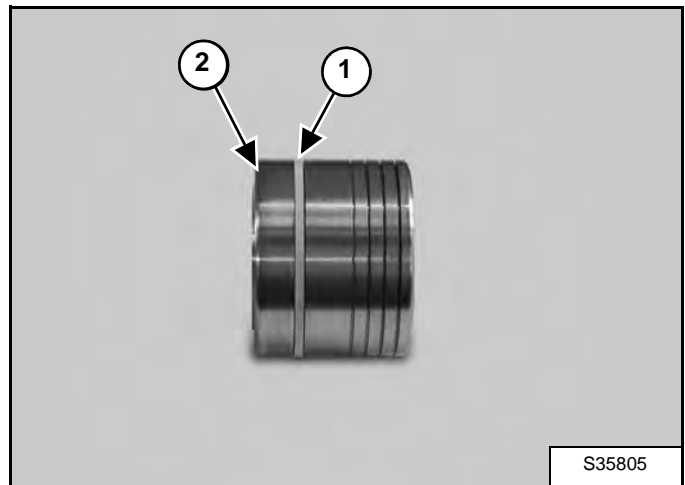

Remove the seal (Item 1) from the piston (Item 2) [Figure 20-20-13].

CYLINDER (ARM) (CONT'D)

Disassembly

Clean the outside of the cylinder before disassembly.

Use the following tools to disassemble the cylinder:

MEL1074 - O-ring Seal Hook

MEL1075 - Adjustable Gland Nut Wrench

MEL1075-2 - Offset Pins

Hold the hydraulic cylinder over a drain pan and move the rod in and out slowly to remove the fluid from the cylinder.

Put the base end of the cylinder in a vise.

Figure 20-21-9

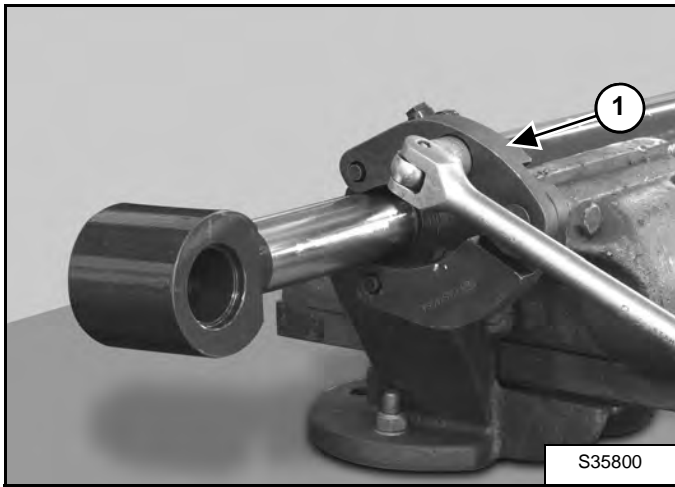

Use the Adjustable Gland Nut Wrench (Item 1) [Figure 20-21-9] to loosen the head.

Remove the head and the rod assembly from the cylinder. Put the rod end in a vise.

Figure 20-21-10

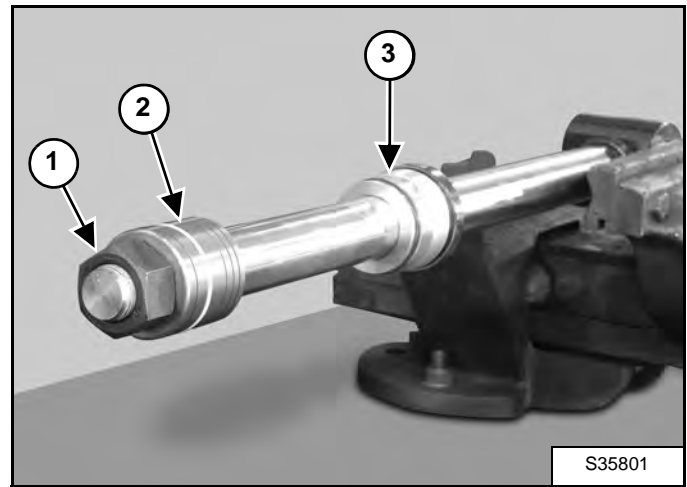

Remove the nut (Item 1), piston (Item 2) and head (Item 3) [Figure 20-21-10].

Figure 20-21-11

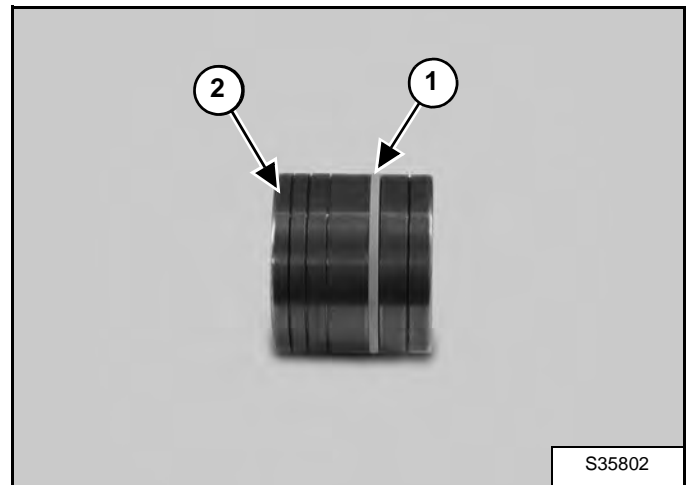

Remove the seal (Item 1) from the piston (Item 2) [Figure 20-21-11].

CYLINDER (BOOM SWING) (CONT'D)

Disassembly (Earlier Models) (Cont'd)

Figure 20-22-15

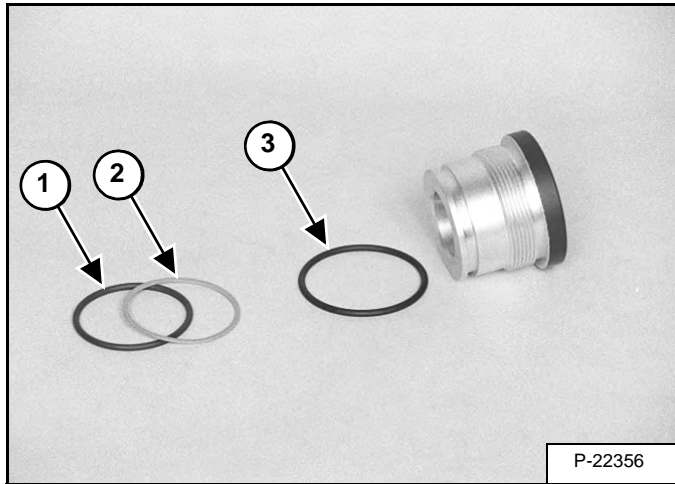

Remove the O-ring (Item 1) and the back-up ring (Item 2) [Figure 20-22-15].

Remove the O-ring (Item 3) [Figure 20-22-15].

Figure 20-22-16

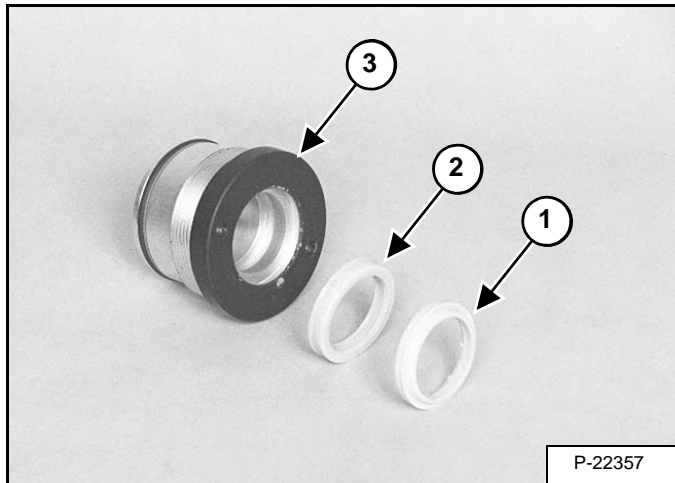

Remove the wiper seal (Item 1) and rod seal (Item 2) from the inside of the head (Item 3) [Figure 20-22-16].

Figure 20-22-17

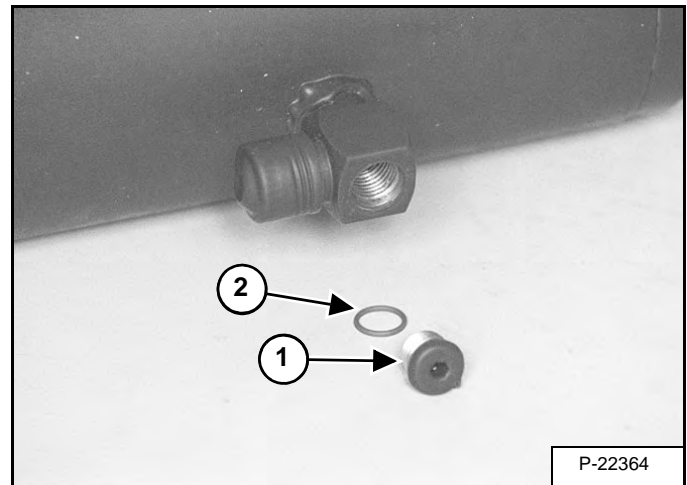

Remove plug (Item 1) and O-ring (Item 2) [Figure 20-22-17].

CYLINDER (BOOM SWING) (CONT'D)

Assembly (Later Models) (Cont'd)

Figure 20-22-47

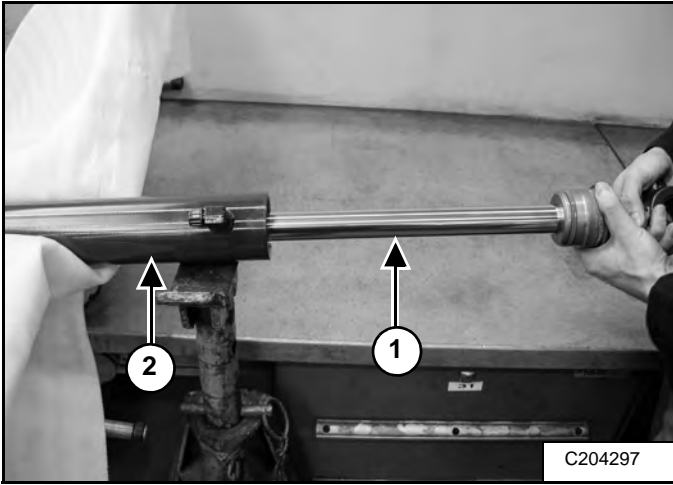

Install the rod assembly (Item 1) into the cylinder (Item 2) [Figure 20-22-47].

Put the base end of the hydraulic cylinder in a vise.

Figure 20-22-48

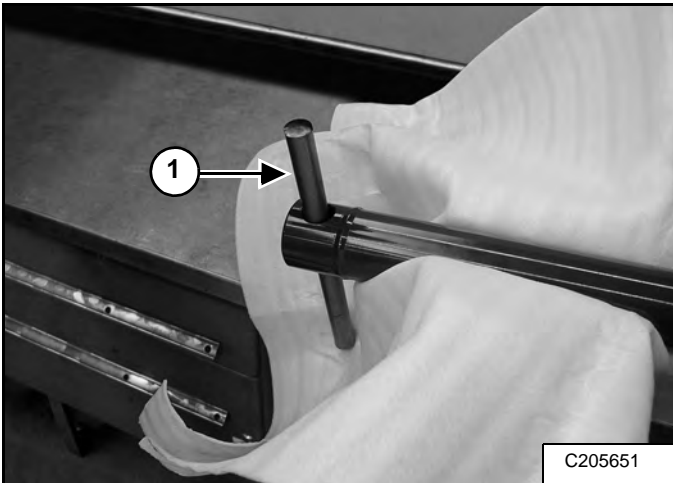

Avoid deformation of cylinder tube. Prevent tube rotation by inserting a bar (Item 1) [Figure 20-22-48] into the base side pin bore.

Figure 20-22-49

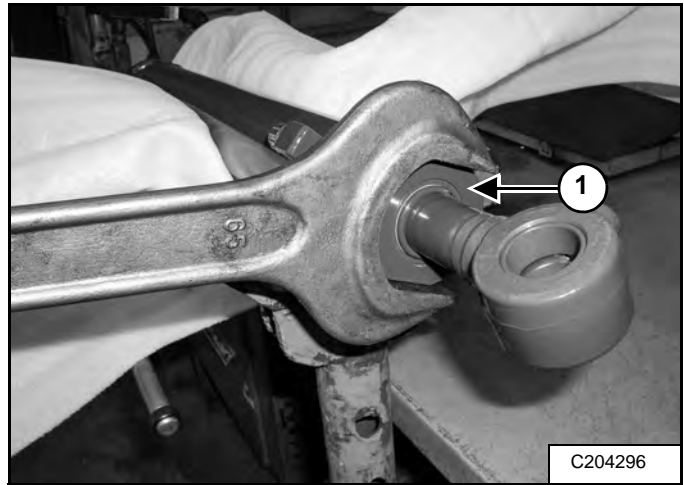

Apply Loctite® 222 or equivalent to the head threads (Item 1) [Figure 20-22-49].

Use an open end wrench to tighten the head (Item 1) [Figure 20-22-49].

Tighten the head to $600 \pm 20 \text{ N}\cdot\text{m}$ ($443 \pm 15 \text{ ft}\cdot\text{lb}$) torque.



Bobcat®

CYLINDER (BLADE) (CONT'D)

Parts Identification (Later Models)

- 1. Rod
- 2. Grease Fitting
- 3. Guide Ring
- 4. Wiper
- 5. Head
- 6. O-ring
- 7. Piston
- 8. O-ring Seal
- 9. Seal
- 10. Bolt
- 11. Housing

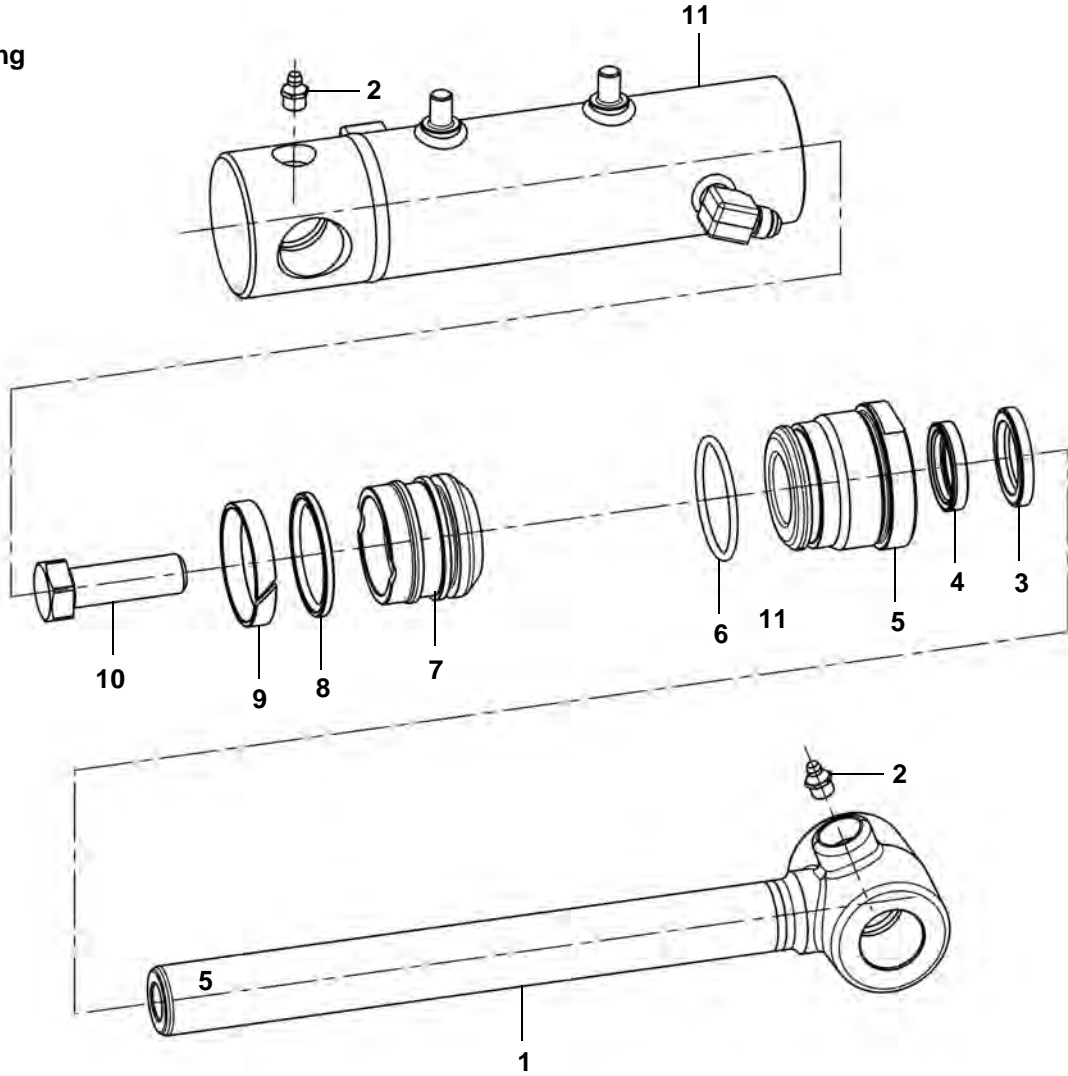

NA19227S

CYLINDER (TRACK FRAME EXPANSION) (CONT'D)

Removal And Installation (Cont'd)

Figure 20-25-12

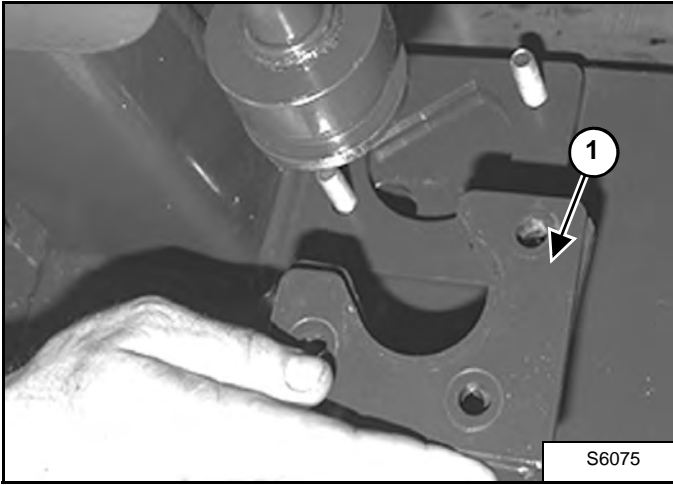

Slightly compress the cylinder. Remove the two plates (Item 1) [Figure 20-25-12] from the rod end of the cylinder.

Figure 20-25-13

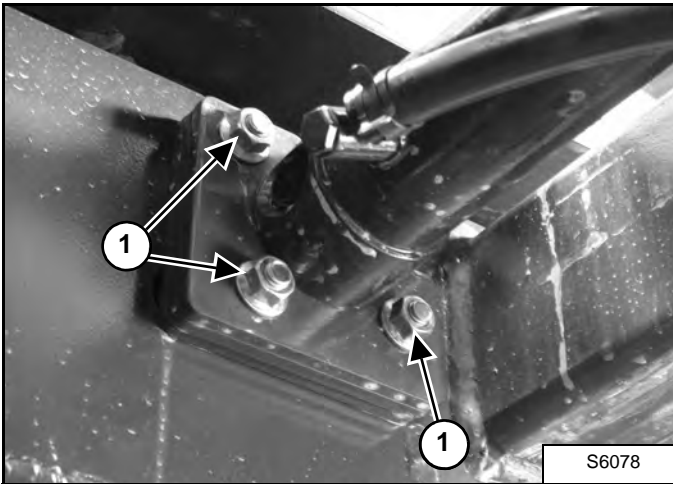

Remove the three nuts (Item 1) [Figure 20-25-13] from the base end of the cylinder.

Installation: Tighten the nuts to 43 - 47 N•m (32 - 35 ft-lb) torque.

Figure 20-25-14

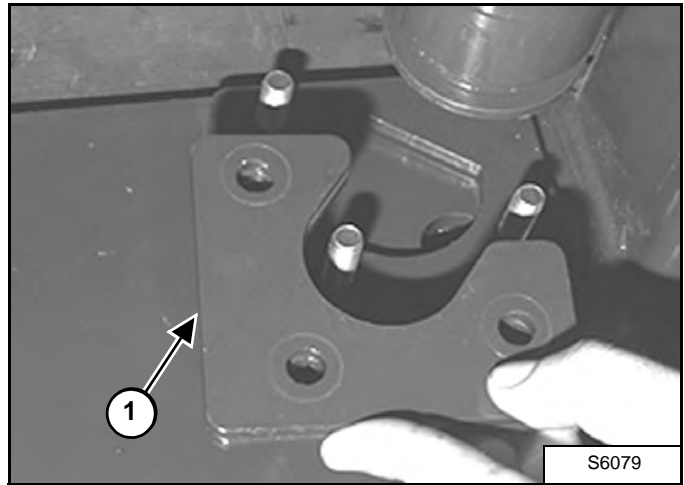

Pull the cylinder out of the mount. Remove the two plates (Item 1) [Figure 20-25-14] from the base end of the cylinder.

CYLINDER (TRACK FRAME EXPANSION) (CONT'D)

Disassembly (Later Models) (Cont'd)

Figure 20-25-35

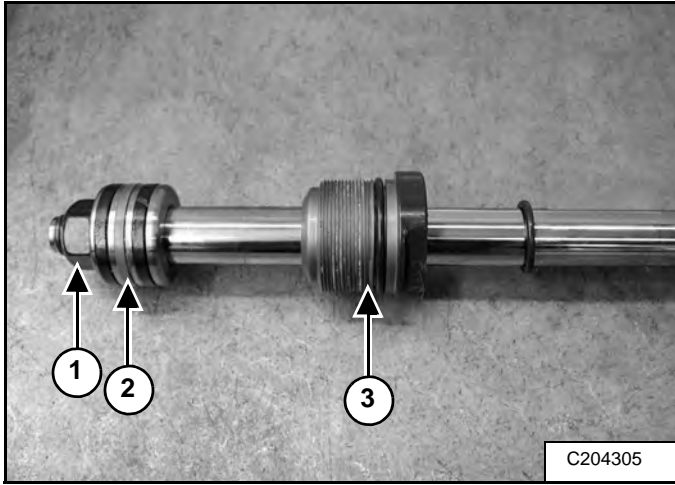

Remove the nut (Item 1), piston (Item 2) and head (Item 3) [Figure 20-25-35].

Figure 20-25-36

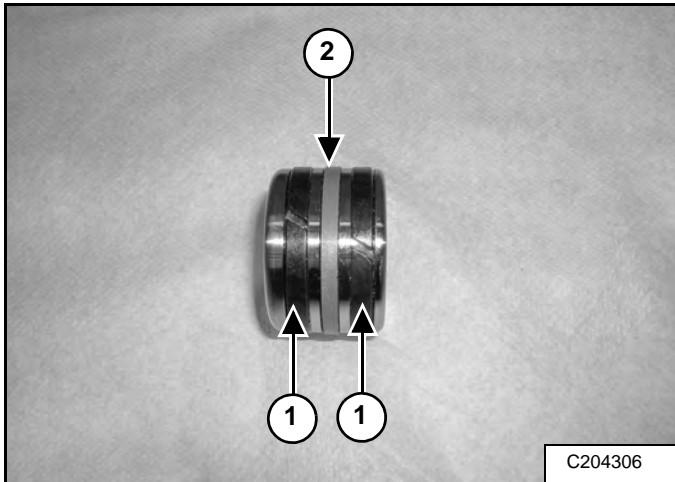

Remove the wear rings (Item 1) and seal (Item 2) [Figure 20-25-36] from the piston.

Remove the O-ring (Item 3) [Figure 20-25-36].

Figure 20-25-37

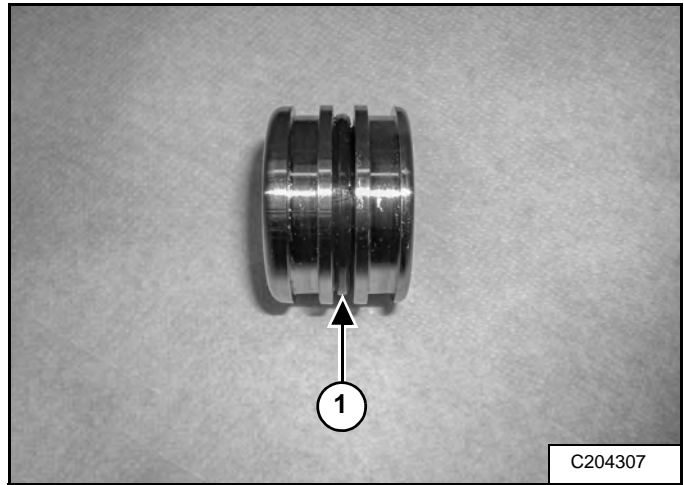

Remove the O-ring (Item 1) [Figure 20-25-37] from the piston.

Figure 20-25-38

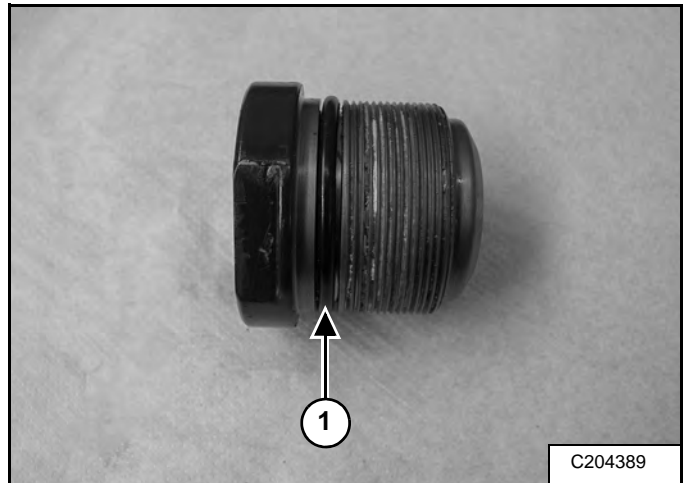

Remove the O-ring (Item 1) [Figure 20-25-38] from the head.

VALVE (PORT RELIEF) (CONT'D)

Testing And Adjusting (Cont'd)

Figure 20-31-2



Install the hand pump hose and a pressure gauge (minimum of 34474 kPa (345 bar) (5000 psi), into the valve section work port in which the port relief valve is located [Figure 20-31-2]. Slowly pressurize this section with the hand pump until the port relief valve opens and make a note of the pressure reading.

NOTE: Pumping the hand pump too fast will alter the pressure readings up to 345 kPa (3,4 bar) (50 psi).

If the port relief pressure setting is incorrect, replace the port relief valve.

WARNING

AVOID INJURY OR DEATH

Wear safety glasses to prevent eye injury when any of the following conditions exist:

- **When fluids are under pressure.**
- **Flying debris or loose material is present.**
- **Engine is running.**
- **Tools are being used.**

W-2019-0907

HYDRAULIC CONTROL VALVE (CONT'D)

Removal And Installation (Cont'd)

Figure 20-40-10

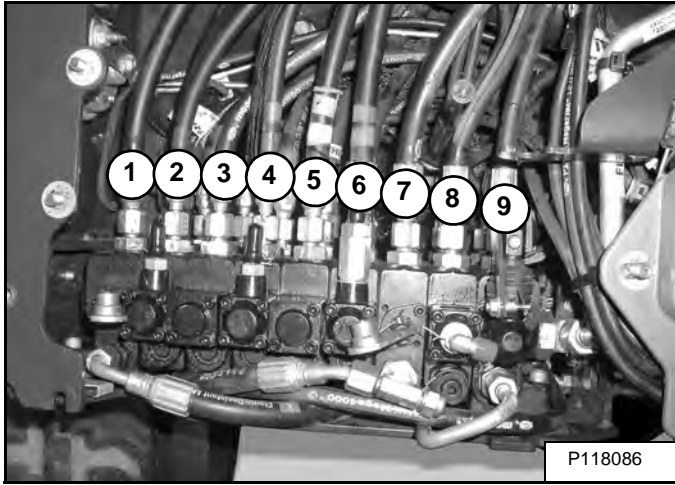
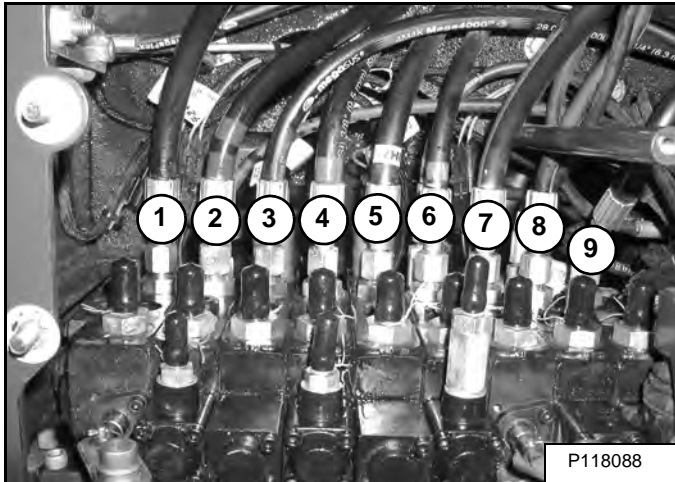
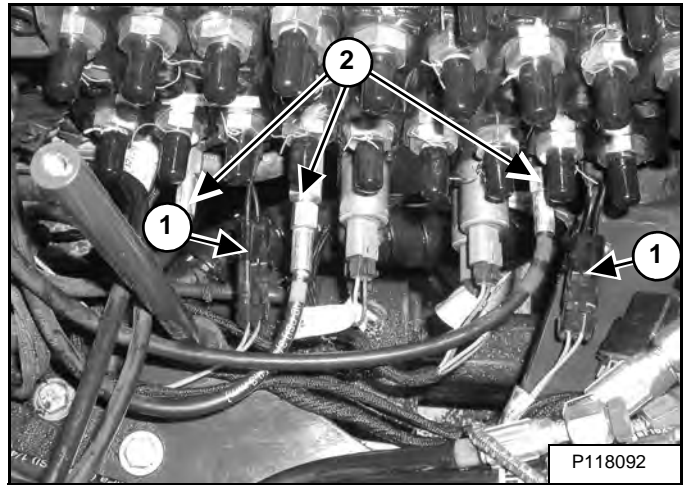

Figure 20-40-11



Remove the eighteen hydraulic control valve hoses [Figure 20-40-10] upper and [Figure 20-40-11] lower.

Figure 20-40-12



Disconnect the two wire harness connectors (if equipped) (Item 1) and remove the three pilot hoses (Item 2) [Figure 20-40-12].

Figure 20-40-13

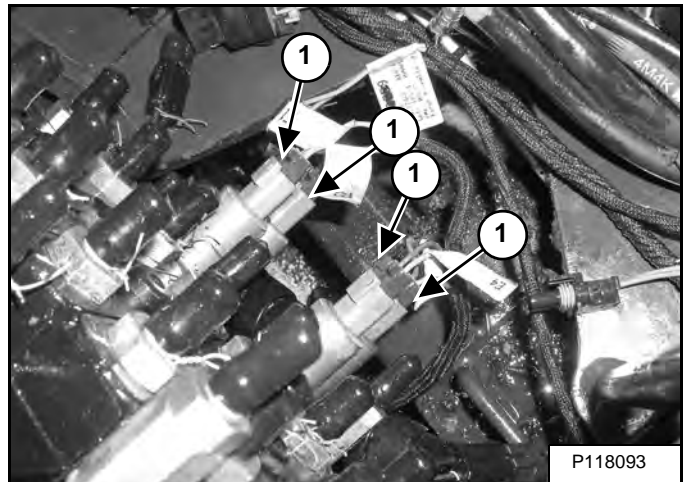

Mark and disconnect the four solenoid wire connectors (if equipped) (Item 1) [Figure 20-40-13].

HYDRAULIC CONTROL VALVE (CONT'D)

Assembly (Cont'd)

Figure 20-40-41

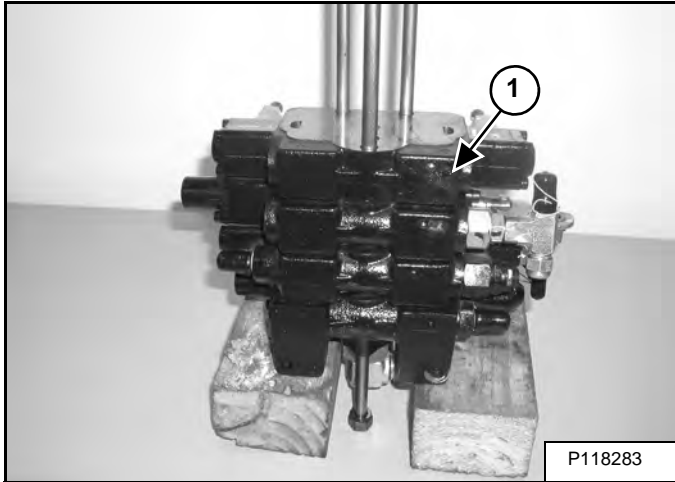

Install the boom valve section (Item 1). Install the O-rings [Figure 20-40-41].

Figure 20-40-42

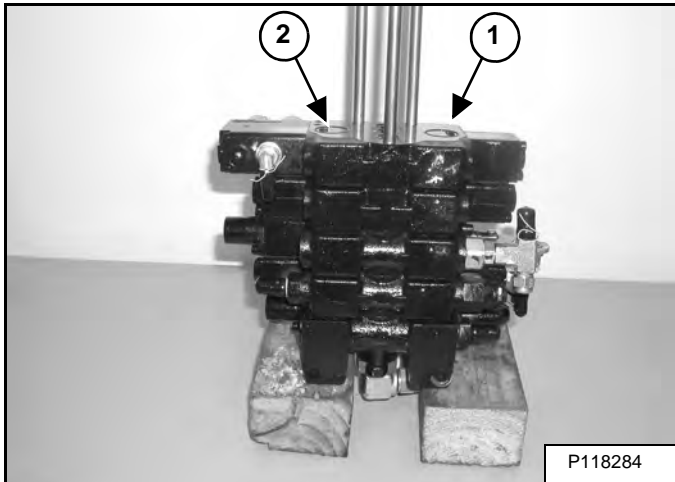

Install the auxiliary valve section (Item 1). Install the seven O-rings (Item 2) [Figure 20-40-42].

Figure 20-40-43

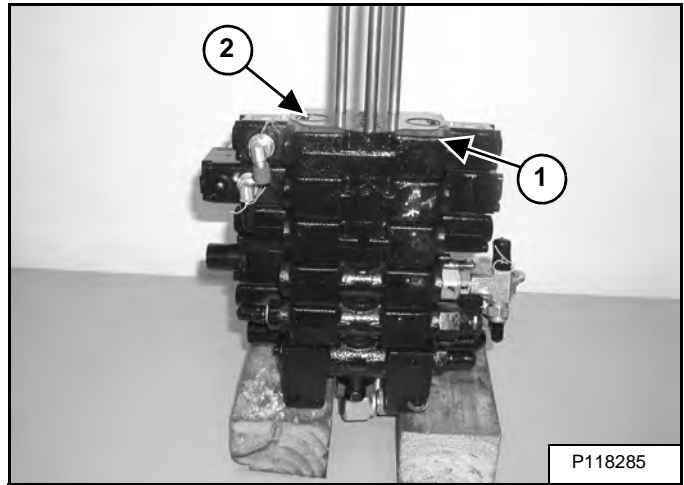

Install the bucket valve section (Item 1). Install the five O-rings (Item 2) [Figure 20-40-43].

Figure 20-40-44

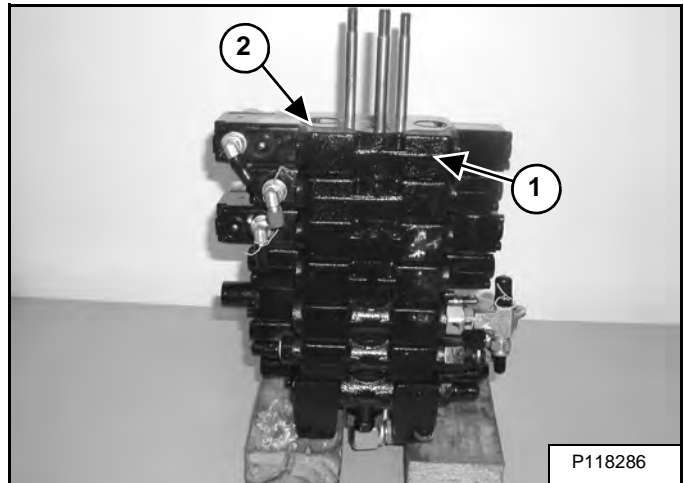

Install the boom swing valve section (Item 1) and five O-rings (Item 2) [Figure 20-40-44].

HYDRAULIC CONTROL VALVE (CONT'D)

Boom Swing And Auxiliary Valve Section Disassembly And Assembly (Cont'd)

Figure 20-40-78

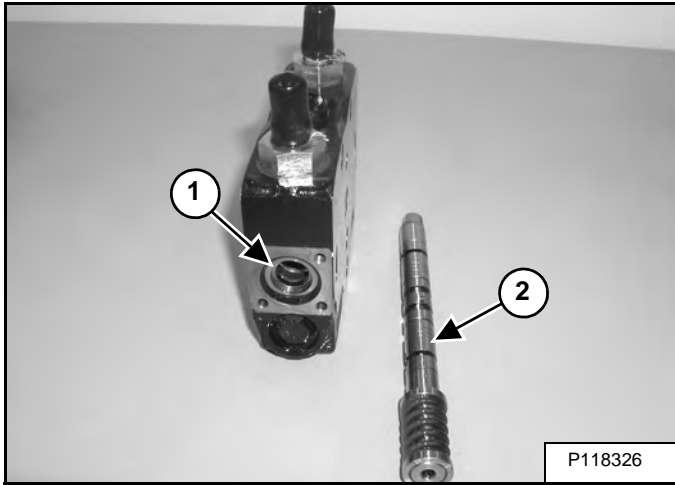

Remove the O-ring (Item 1) and spool assembly (Item 2) [Figure 20-40-78].

Figure 20-40-79

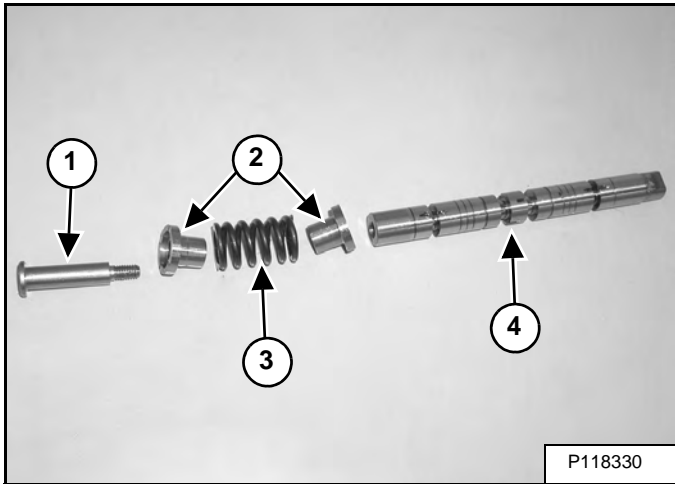

Remove bolt (Item 1), retainers (Item 2), spring (Item 3) from spool (Item 4) [Figure 20-40-79].

Figure 20-40-80

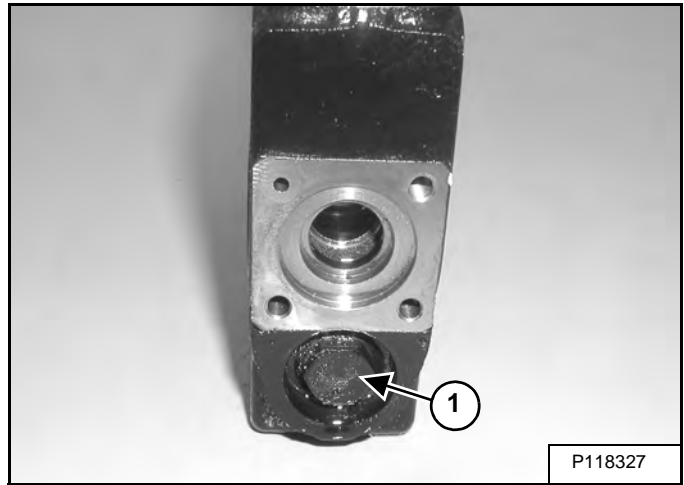

Remove the plug (Item 1) on both sides [Figure 20-40-80].

Figure 20-40-81

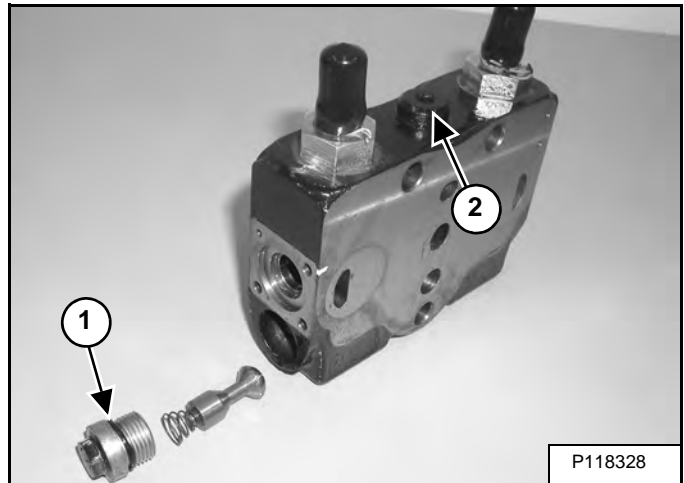

Remove the O-ring (Item 1) from both plugs and remove the check valve (Item 2) [Figure 20-40-81].

Installation: Tighten the plug to 69 - 78 N•m (51 - 58 ft-lb) torque.



Bobcat®

HYDRAULIC PUMP (CONT'D)

Assembly

Clean all parts in solvent and dry with compressed air.

Inspect all parts for wear or damage. Replace any worn or damaged parts.

Always install new seals and O-rings. Lubricate all seals and O-rings with clean hydraulic fluid and all E-seals with assembly lube before installation.

Use the correct size driver and install the oil seal (seal lips to the inside of the pump) (Item 4) into the mounting flange (Item 2). Install the retaining ring (Item 1) [Figure 20-50-20].

Figure 20-50-21

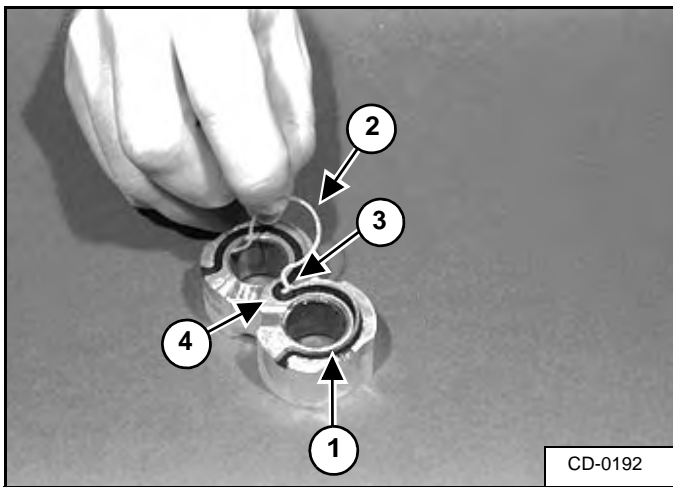

Install an E-seal (Item 1) [Figure 20-50-21] stepped side up, into each E-seal groove. Push each E-seal down into the groove.

Install the back-up ring (Item 2) [Figure 20-50-21] into the groove made by the E-seal and bearing. Push the back-up ring down flush with the E-seal.

NOTE: There is a notch (Items 3 and 4) [Figure 20-50-21] in the center of the back-up ring and E-seal. When installing the back-up ring, make sure that these notches are aligned. If the back-up ring or E-seal are not installed correctly the back-up ring will not sit flush with the E-seal.

Figure 20-50-22

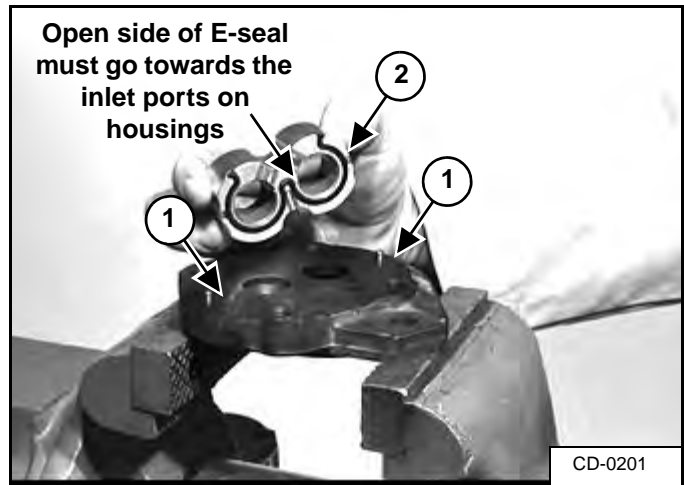

Put the mounting flange, oil seal side down, in a protected jaw vise [Figure 20-50-22].

Install the two dowel pins (Item 1) [Figure 20-50-22] into the mounting flange (or separating plate).

Install the lower bearing (Item 2), seal side down, on the mounting flange (or separating plate). The open side of the E-seal must point toward the inlet port side (marked side) of the pump [Figure 20-50-22].

Figure 20-50-23

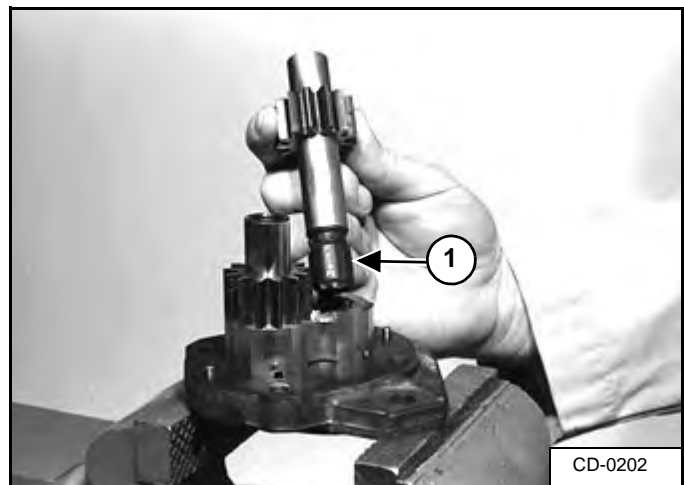

Tape the splined end (Item 1) [Figure 20-50-23] of the drive gear to make sure that the splines will not damage the oil seal during installation.

Apply oil to the drive gear and idler gear and to the side faces of the gears. Install the gears into the lower bearing [Figure 20-50-23].

MANIFOLD ASSEMBLY / ACCUMULATOR (CONT'D)

Disassembly And Assembly

Figure 20-60-10

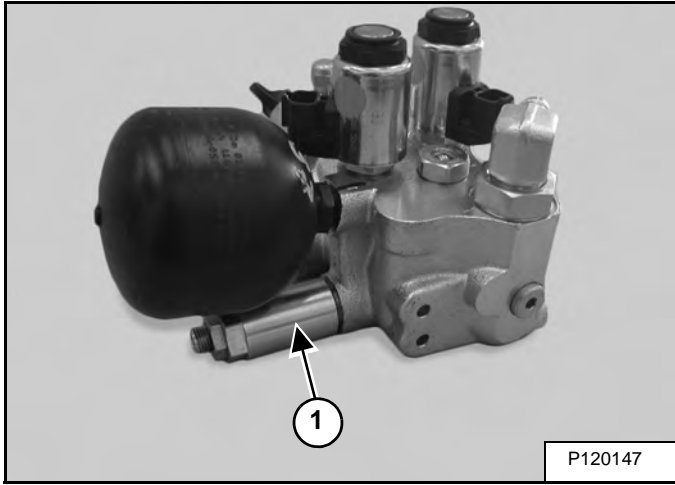

Clean the outside of the manifold assembly / accumulator before disassembly.

Remove the pressure reducing valve (Item 1) [Figure 20-60-10].

Installation: Tighten the valve to 30 N•m (22 ft-lb) torque.

Figure 20-60-11

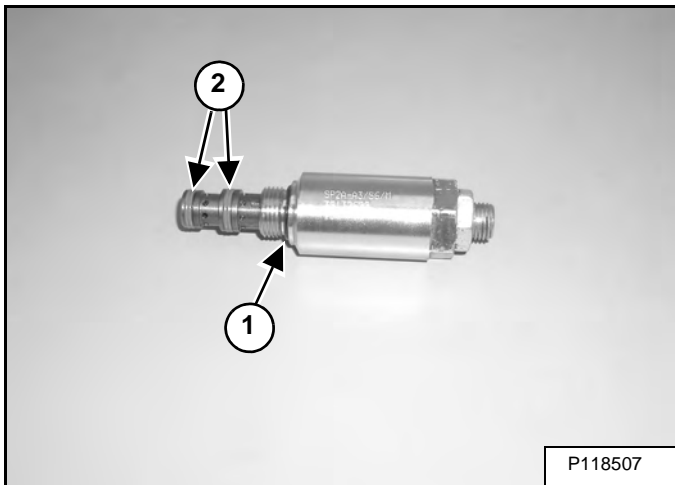

Remove the O-ring (Item 1) and the two seals (Item 2) [Figure 20-60-11].

Figure 20-60-12

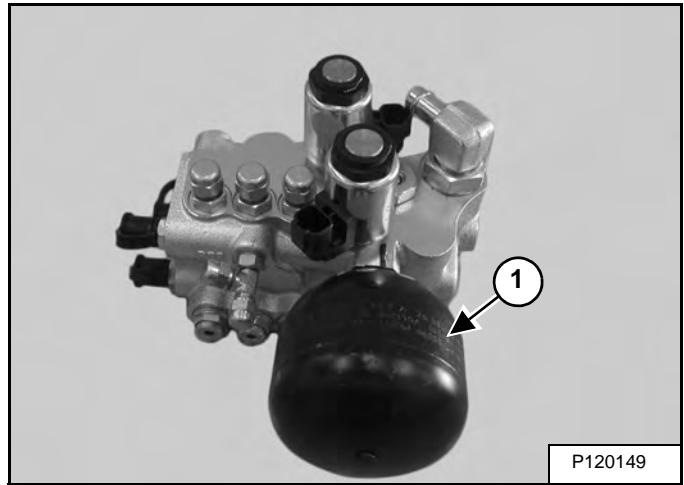

Remove the accumulator (Item 1) [Figure 20-60-12].

Figure 20-60-13

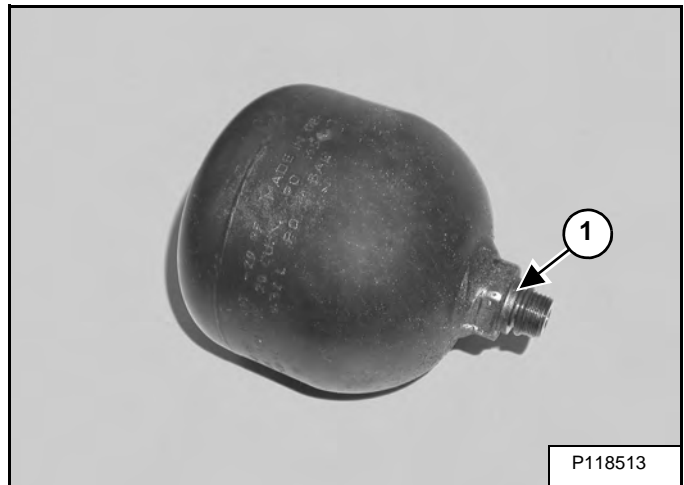

Remove the O-ring (Item 1) [Figure 20-60-13] from the accumulator.

Installation: Tighten the accumulator to 29 - 33 N•m (22 - 24 ft-lb) torque.

TRAVEL MOTOR (SINGLE SPEED) (CONT'D)

Disassembly (Cont'd)

Figure 20-80-7

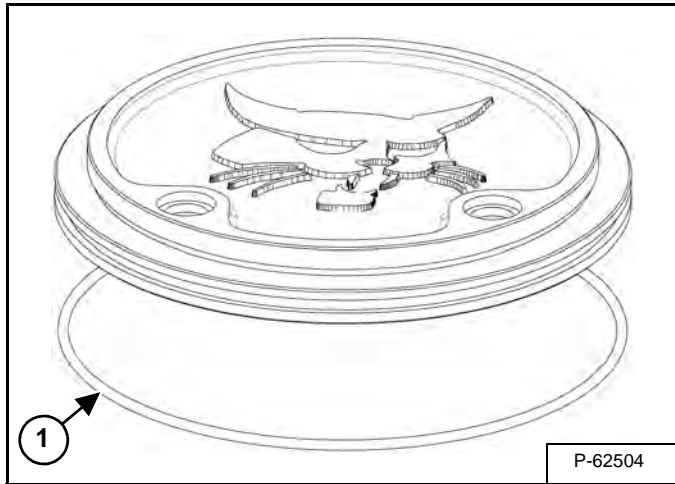

Remove the O-ring (Item 1) [Figure 20-80-7] from the cover.

Figure 20-80-8

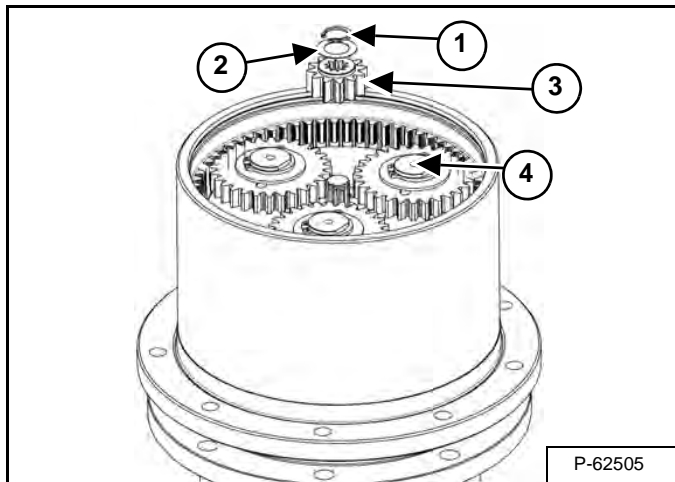

Remove the retaining ring (Item 1), shims (Item 2) and sun gear (Item 3) [Figure 20-80-8].

Remove the first stage planetary carrier (Item 4) [Figure 20-80-8] using your hands.

Figure 20-80-9

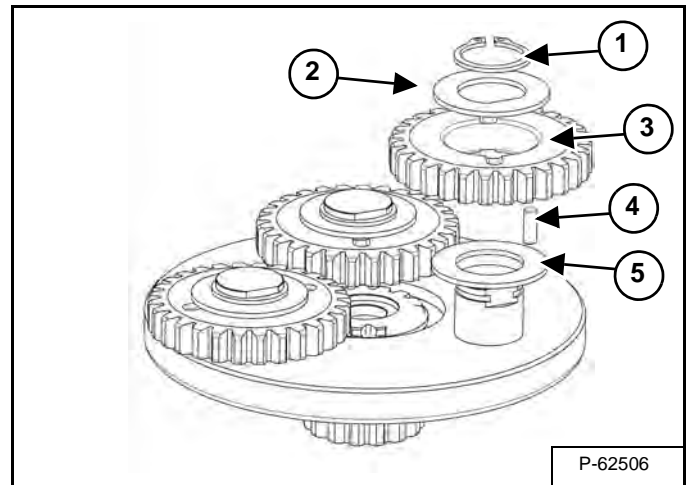

Remove the retaining rings (Item 1), anti-rotation washer (Item 2), planetary gears (Item 3), needle bearings (Item 4) and thrust washer (Item 5) [Figure 20-80-9] from the first stage planetary carrier assembly.

Figure 20-80-10

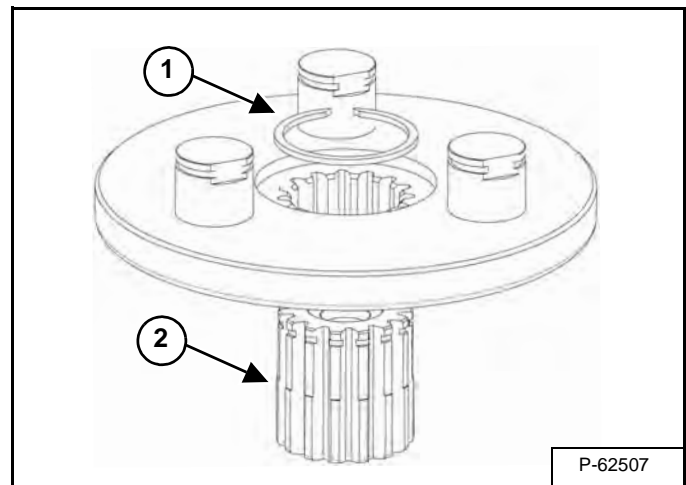

Remove the retaining ring (Item 1) from the second reduction sun gear (Item 2) [Figure 20-80-10] and push the gear down to remove from planetary carrier.

TRAVEL MOTOR (SINGLE SPEED) (CONT'D)

Assembly (Cont'd)

Figure 20-80-43

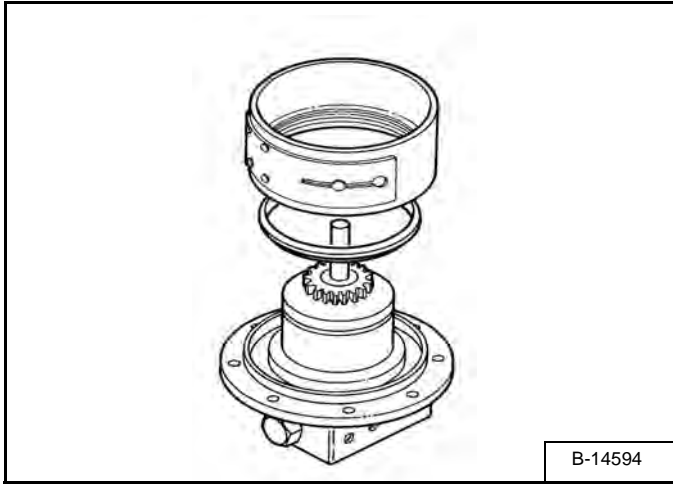

Install the seal seating tool (MEL1468) on the seal ring [Figure 20-80-43].

Figure 20-80-44

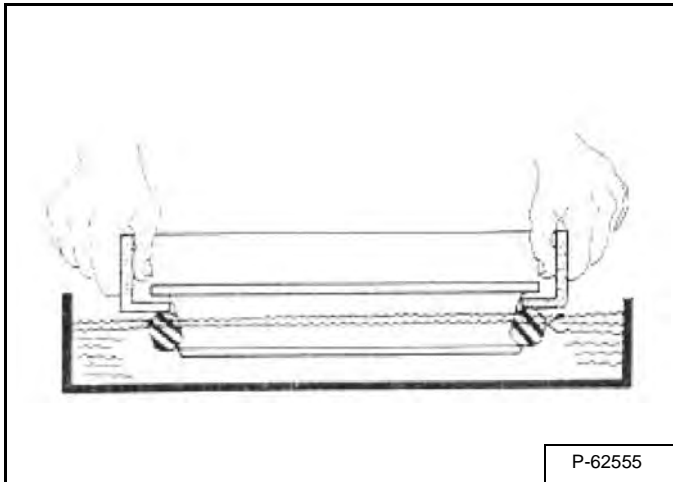

The seal ring assembly [Figure 20-80-44] must be lubricated with alcohol, so the O-ring will slip past the housing retaining ring and seal uniform in the motor housing radius.

The O-ring [Figure 20-80-44] on the seal ring assembly must be lubricated with alcohol.

This will allow the O-ring to slide on the motor housing sealing surface without twisting.

Dip the O-ring [Figure 20-80-44] and seal ring assembly in a pan of alcohol.

Shake off the excess alcohol and install the seal ring assembly on the motor [Figure 20-80-44].

Figure 20-80-45

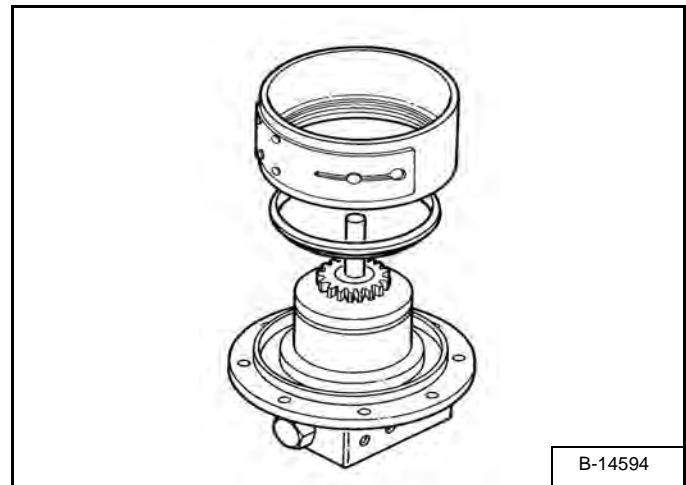

Use firm even pressure on the installation tool (MEL1468) to pop the O-ring into the motor housing [Figure 20-80-45].

Figure 20-80-46

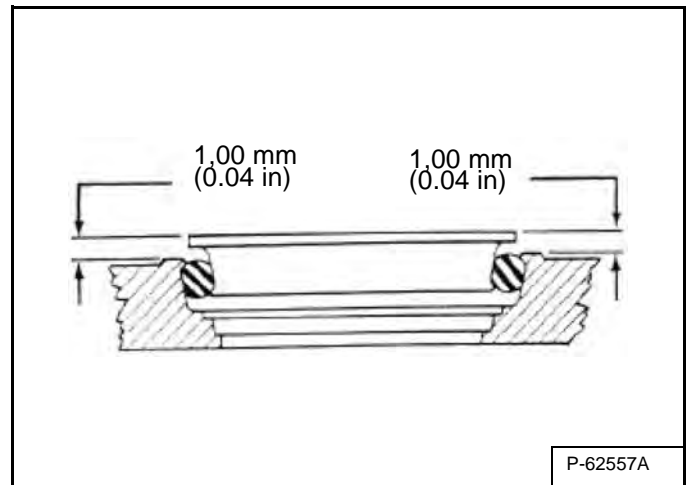

After the seal ring is installed, check the stand out height [Figure 20-80-46] in four places, 90° apart.

The stand out height is 1,00 mm (0.04 in).

NOTE: If the seal ring does not meet the height specifications inspect the torque ring for twists or obvious bulges.

Apply a light film of oil to the seal ring and lapped face of the bearing.

NOTE: Do not get any oil on the O-ring.

TRAVEL MOTOR (TWO SPEED) (CONT'D)

Disassembly (Cont'd)

Figure 20-81-15

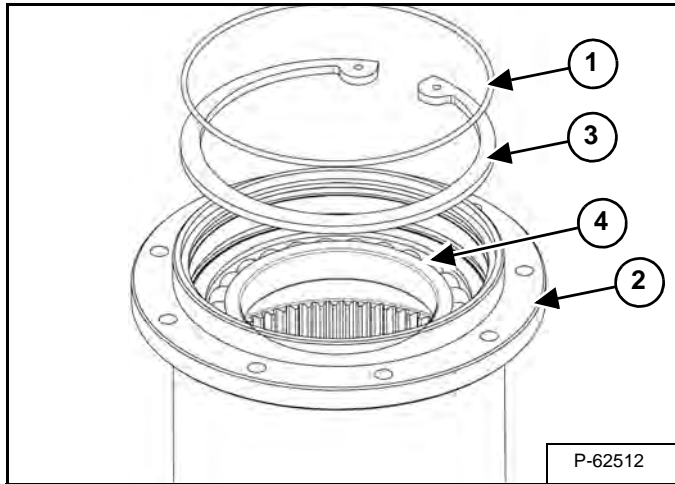

Remove the O-ring (Item 1) from the ring gear (Item 2) and the retaining ring (Item 3) securing the bearing (Item 4) [Figure 20-81-15].

Figure 20-81-16

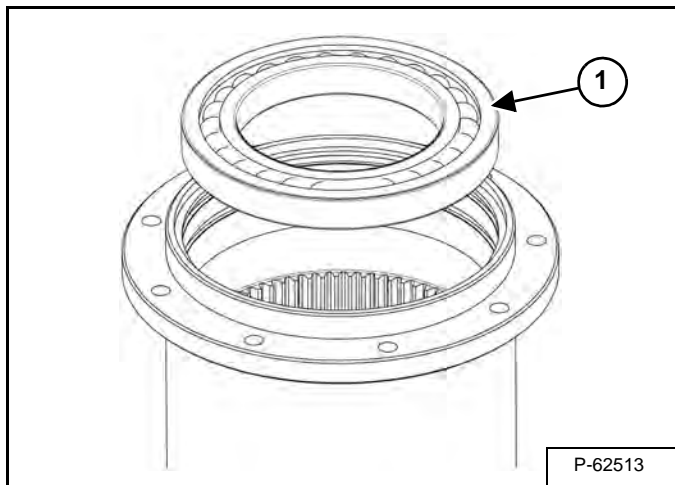

Remove the ball bearing (Item 1) [Figure 20-81-16] by pushing from underneath.

Figure 20-81-17

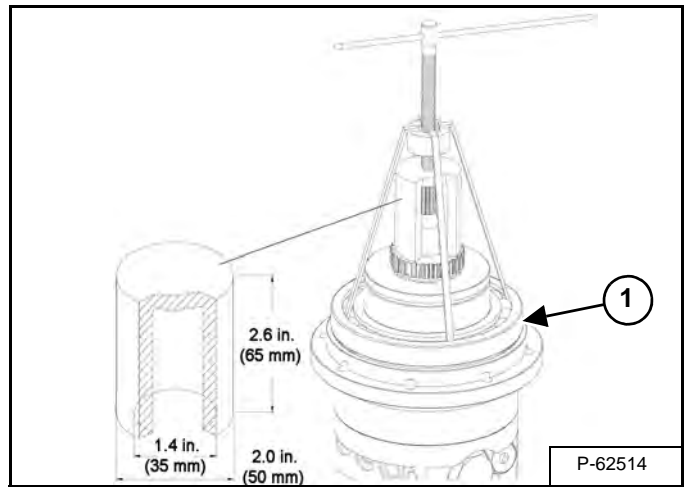

Remove the lapped bearing / front seal (Item 1) [Figure 20-81-17].

NOTE: Be careful not to damage the bottom polished / lapped surface of the bearing [Figure 20-81-17].

NOTE: A commercial bearing extractor and supporting cap, as shown, will be required for bearing removal [Figure 20-81-17]. Be careful not to damage the bottom polished / lapped surface of the bearing.

Figure 20-81-18

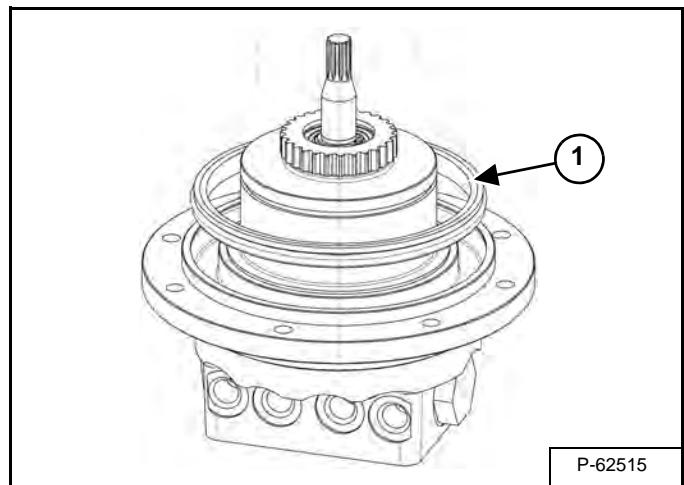

Remove the front seal ring (Item 1) [Figure 20-81-18].

TRAVEL MOTOR (TWO SPEED) (CONT'D)

Assembly (Cont'd)

Figure 20-81-52

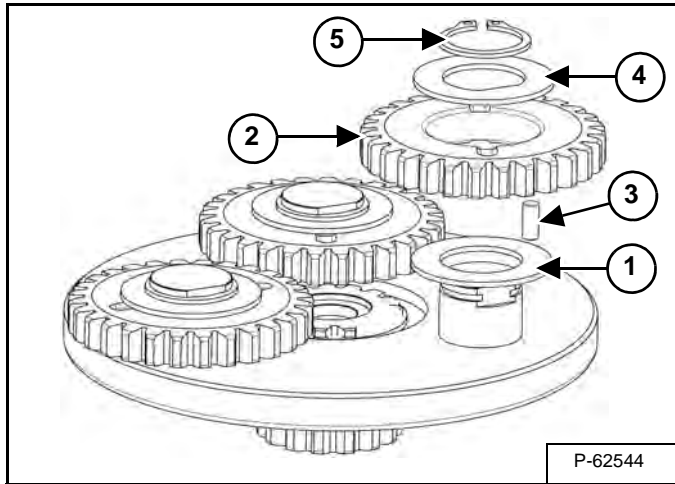

Install the thrust washers (Item 1), planetary gears (Item 2), needle bearings (Item 3), anti-rotation washers (Item 4) and external snap rings (Item 5) [Figure 20-81-52].

NOTE: Install the snap rings so the opening of the snap ring is towards the outside.

Figure 20-81-53

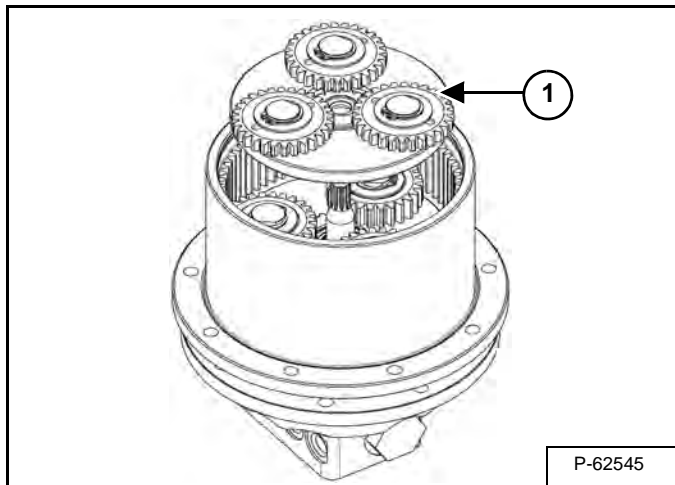

Install the outer planetary assembly (Item 1) [Figure 20-81-53].

Figure 20-81-54

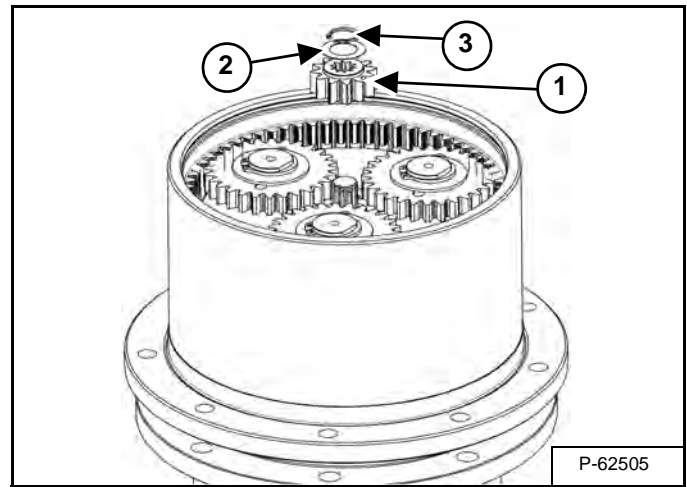

Install the sun gear (Item 1), shims (theoretical shimming 0,5 mm (0.02 in) (Item 2) and retaining ring (Item 3) [Figure 20-81-54].

Figure 20-81-55

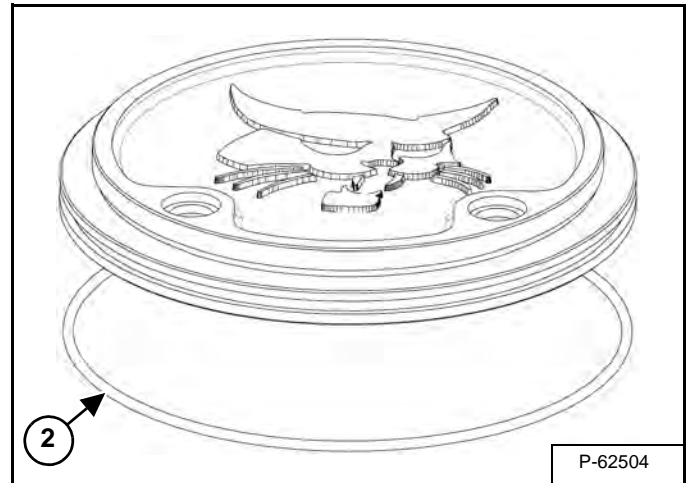

Install the O-ring (Item 1) [Figure 20-81-55] on the cover.

SWIVEL JOINT (CONT'D)

Assembly (Cont'd)

Figure 20-90-21

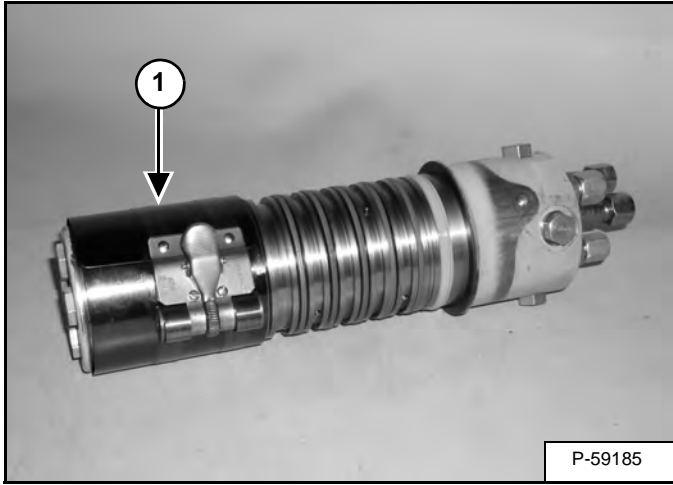

NOTE: A ring compressor (Item 1) [Figure 20-90-21] may be used to fit the seals into the seal groove. Compress the seals for three minutes.

Figure 20-90-22

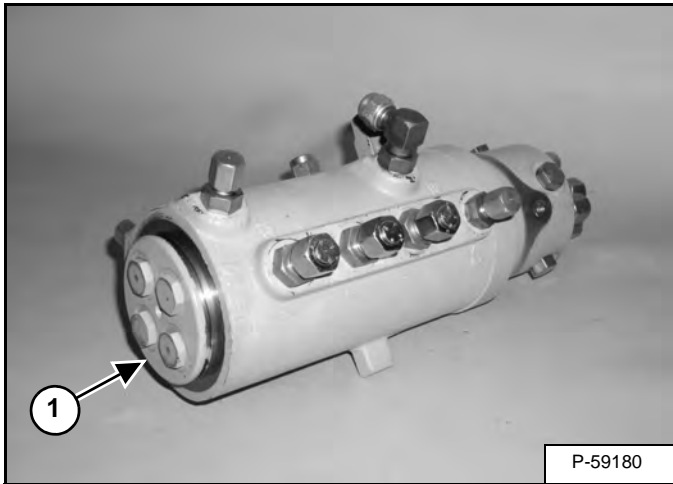

Apply hydraulic fluid to the rotor. Install the rotor (Item 1) [Figure 20-90-22] in the housing.

Figure 20-90-23

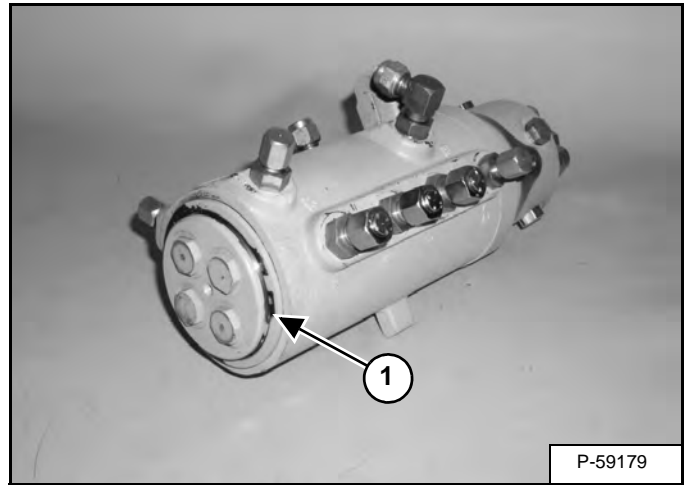

Install the nylon washer (Item 1) [Figure 20-90-23].

Figure 20-90-24

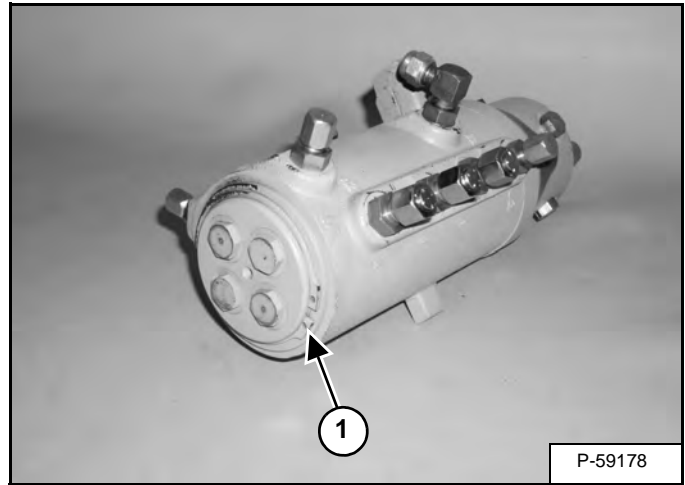

Install the snap ring (Item 1) [Figure 20-90-24].

SWING MOTOR (CONT'D)

Motor Disassembly (Cont'd)

Figure 20-100-20

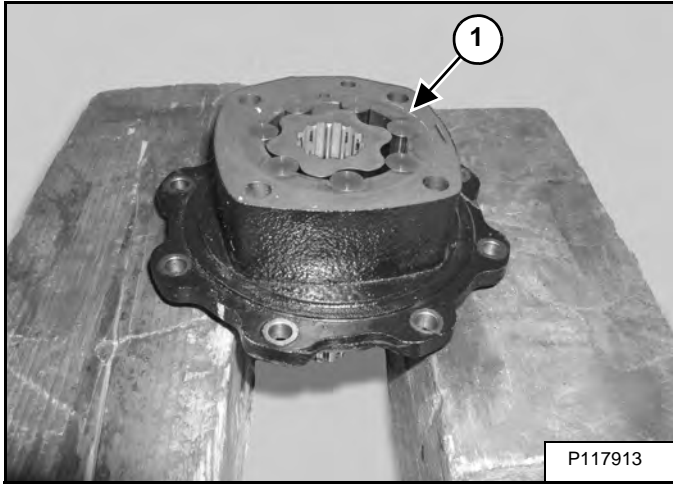

Remove the Geroler® (Item 1) [Figure 20-100-20].

NOTE: Do not disassemble the Geroler®.

Figure 20-100-21

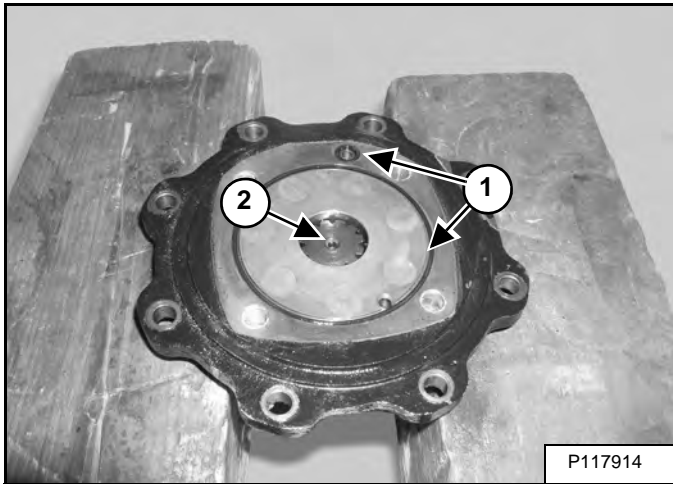

Remove the O-rings (Item 1) [Figure 20-100-21].

Remove the drive (Item 2) [Figure 20-100-21].

Figure 20-100-22

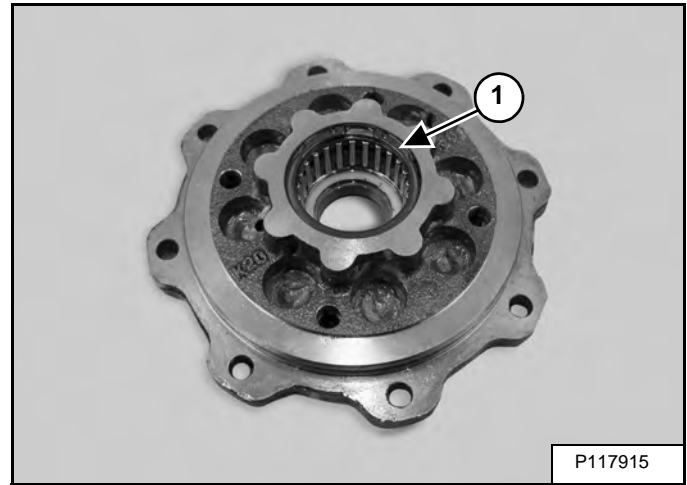

Turn the housing over and remove the snap ring (Item 1) [Figure 20-100-22].

Figure 20-100-23

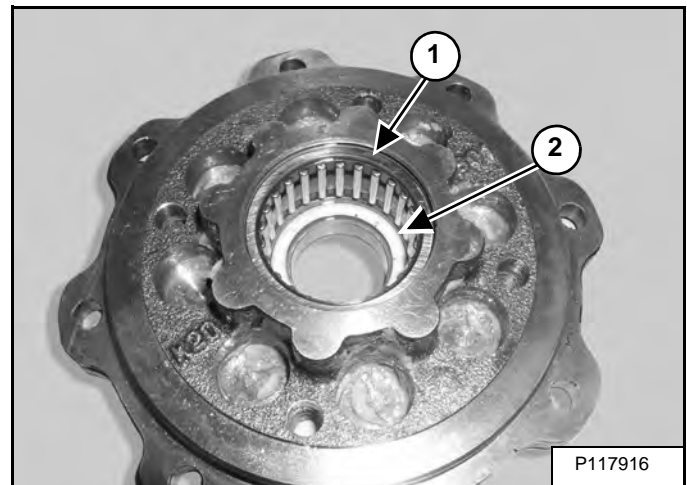

Remove the bearing (Item 1) and remove the seal (Item 2) [Figure 20-100-23].

SWING MOTOR (CONT'D)

Brake Carrier Disassembly And Assembly (Cont'd)

Figure 20-100-55

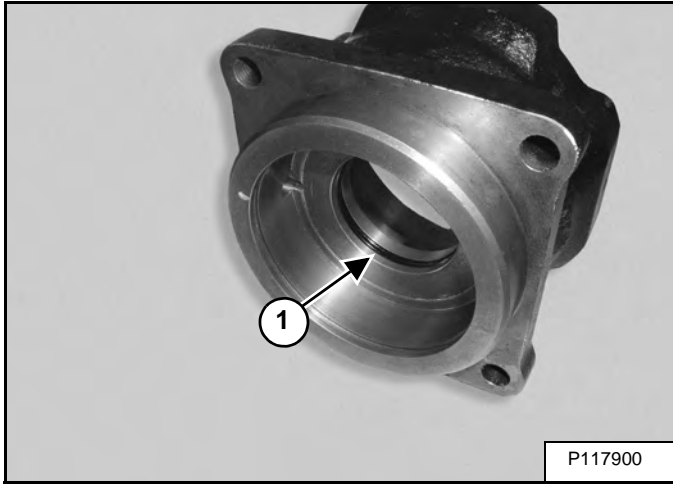

Remove the seal (Item 1) [Figure 20-100-55] from the housing.

Figure 20-100-56

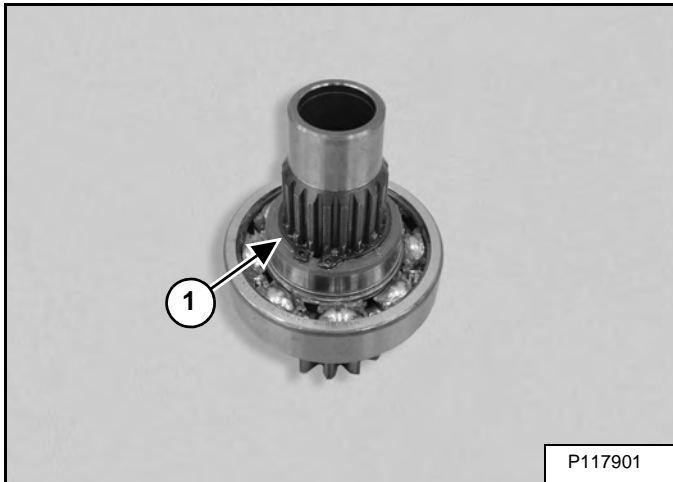

Remove the snap ring (Item 1) [Figure 20-100-56].

Figure 20-100-57

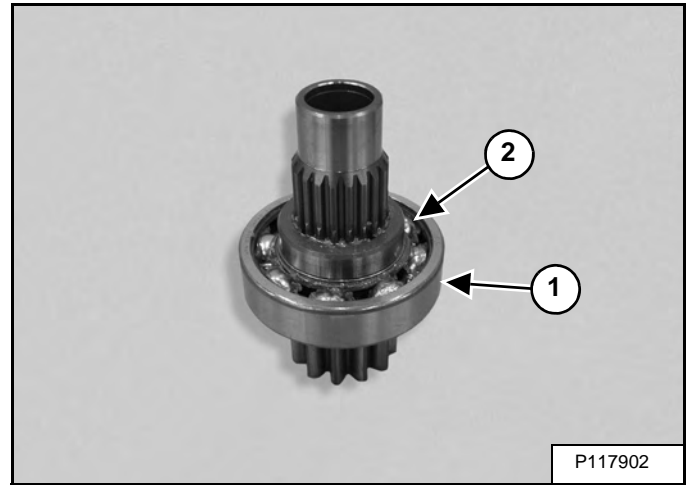

Press the collar (Item 1) and bearing (Item 2) [Figure 20-100-57] off the shaft.

CLICK HERE TO **DOWNLOAD** THE COMPLETE MANUAL

- Thank you very much for reading the preview of the manual.
- You can download the complete manual from: www.heydownloads.com by clicking the link below



- Please note: If there is no response to CLICKING the link, please download this PDF first and then click on it.

CLICK HERE TO **DOWNLOAD** THE COMPLETE MANUAL

CONTROL LEVER (JOYSTICK) (RIGHT) (CONT'D)

Disassembly (Cont'd)

Figure 20-110-29

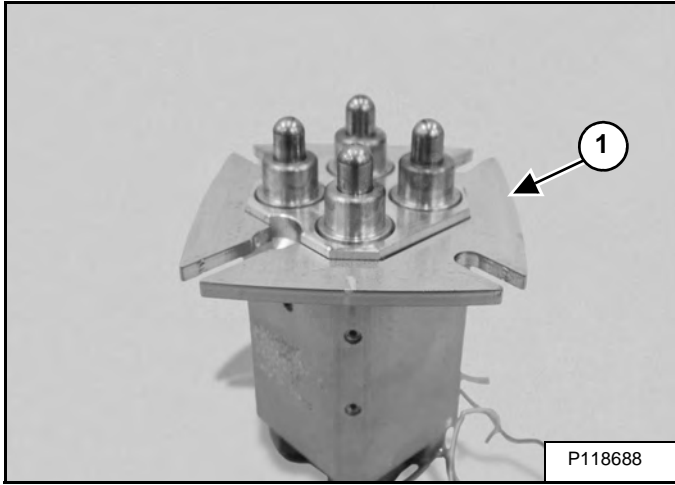

Remove the bottom plate (Item 1) [Figure 20-110-29].

Figure 20-110-30

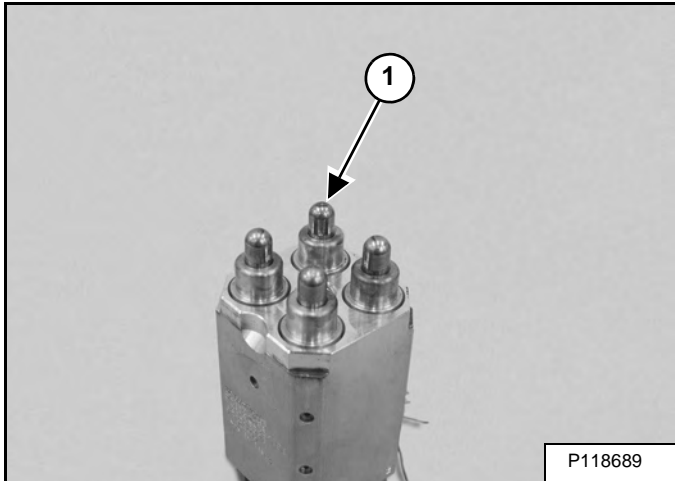

Remove the plunger assemblies (Item 1) [Figure 20-110-30].

Figure 20-110-31

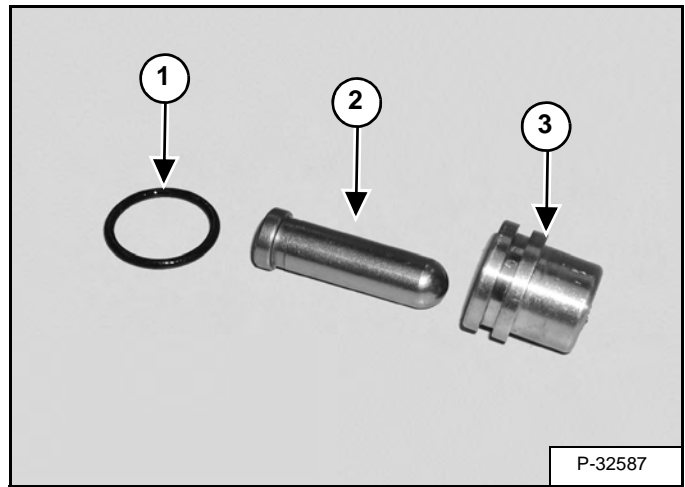

Remove the O-ring (Item 1) and plunger (Item 2) from the bushing (Item 3) [Figure 20-110-31].

NOTE: Mark the spool assemblies for installation in their original location.

Figure 20-110-32

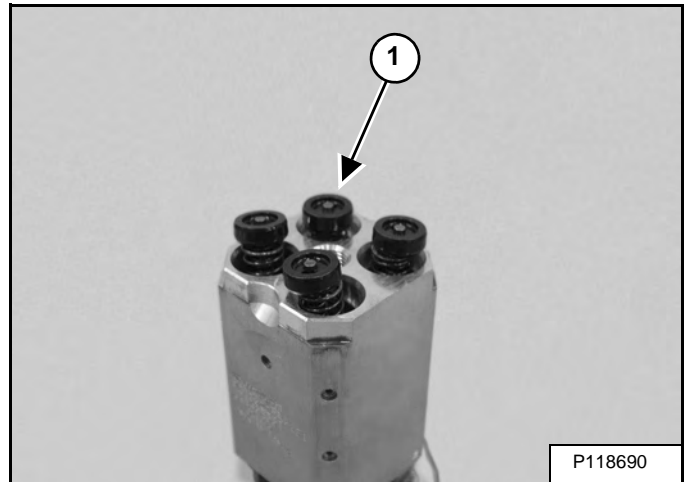

Remove the spool assemblies (Item 1) [Figure 20-110-32].

CONTROL LEVER (JOYSTICK) (LEFT) (CONT'D)

Removal and Installation

Lower the boom / bucket and blade to the ground.

Stop the engine.

Relieve hydraulic pressure.

Remove the left console cover. (See Removal And Installation on Page 40-60-1.)

IMPORTANT

When repairing hydrostatic and hydraulic systems, clean the work area before disassembly and keep all parts clean. Always use caps and plugs on hoses, tubelines and ports to keep dirt out. Dirt can quickly damage the system.

I-2003-0888

Figure 20-111-11

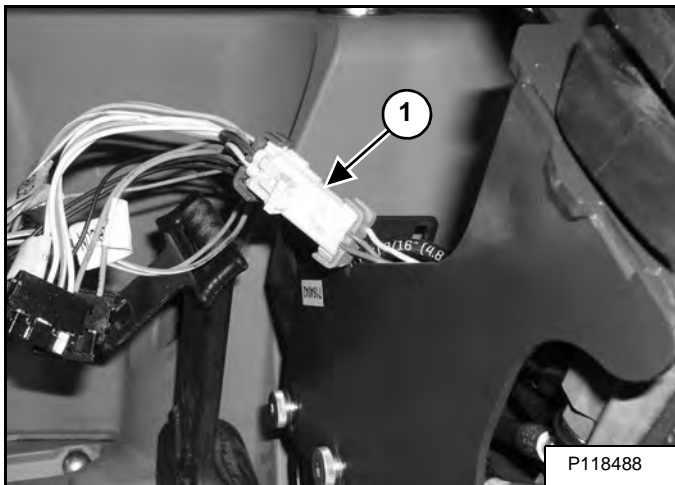

Disconnect the wire harness (Item 1) [Figure 20-111-11].

Figure 20-111-12

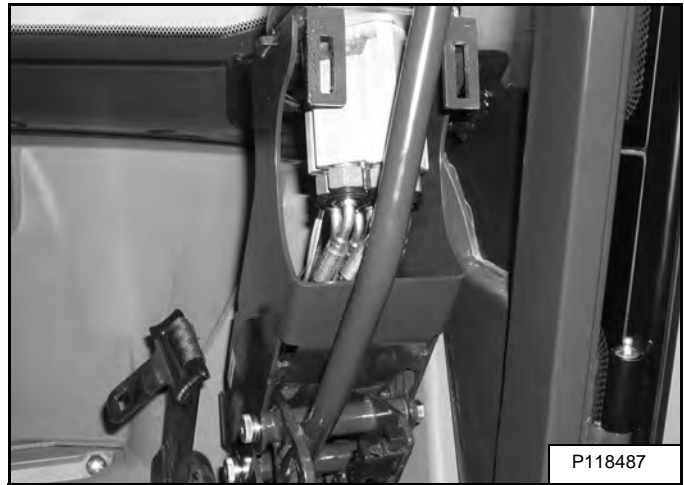

Mark and remove the hoses [Figure 20-111-12].

Remove the hoses while the control lever (joystick) is bolted to the console [Figure 20-111-12].

Figure 20-111-13

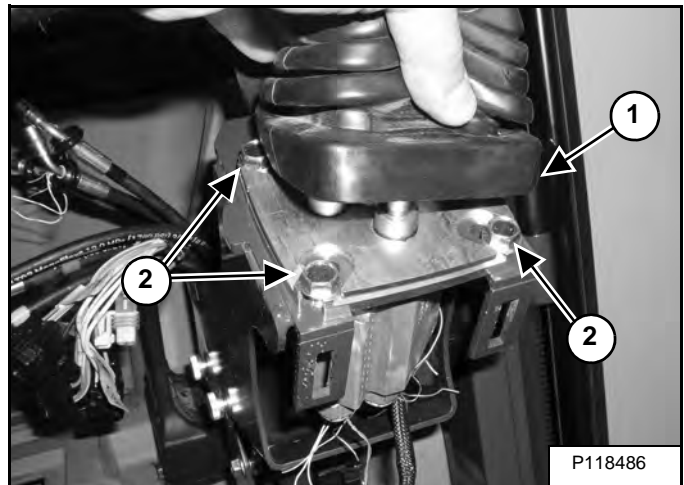

Pull the boot (Item 1) [Figure 20-111-13] up from the plate.

Remove the bolts (Item 2) [Figure 20-111-13].

Remove the joystick assembly.



Bobcat®

BLADE / TRACK EXPANSION SOLENOID BLOCK (CONT'D)

Parts Identification

- 1. Seal
- 2. O-ring
- 3. Relief Valve
- 4. Solenoid Nut
- 5. Solenoid
- 6. Solenoid Stem
- 7. Solenoid Block

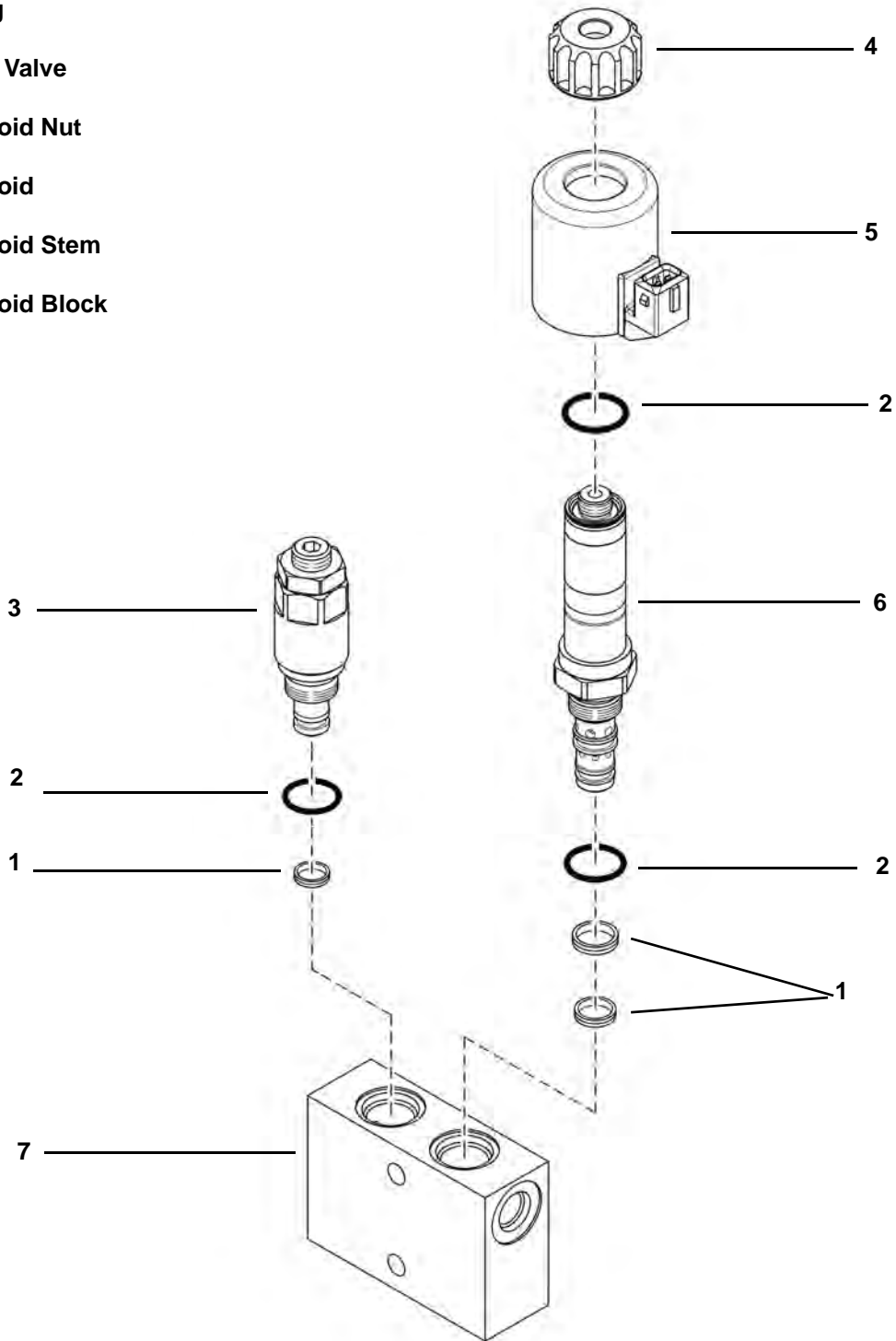

TRACK UNDERCARRIAGE COMPONENTS (CONT'D)

Adjusting Tension (Cont'd)

Decrease Track Tension

WARNING

AVOID INJURY OR DEATH

If grease fitting is removed before pressure is released, the fitting can come off with great force and cause serious injury or death.

W-2490-0104

Pressure must be released from the grease cylinder to decrease track tension.

Loosen the bleed fitting (Item 2) [Figure 30-20-9] (NOT the grease fitting) and release pressure until the track tension is correct.

NOTE: DO NOT loosen the bleed fitting (Item 2) [Figure 30-20-9] for more than eight turns.

Tighten the bleed fitting to 80 - 100 N•m (59 - 74 ft-lb) torque.

Pivot the access cover closed and tighten the access cover bolts.

Repeat the procedure for the other side.

If the track tension is still loose after adjusting to the mentioned limit, it indicates the track is worn.

WARNING

AVOID INJURY OR DEATH

Do not loosen the grease fitting more than one complete rotation. Also, be careful not to loosen any part other than the grease fitting. If the grease fitting or any part is loosened too much, it can fly off under high pressure. If the grease does not ooze smoothly, try moving the machine back and forth for a short distance.

W-2143-0189

WARNING

HIGH PRESSURE GREASE CAN CAUSE SERIOUS INJURY

- Do not loosen grease fitting.
- Do not loosen bleed fitting more than 1 - 1/2 turns.

W-2781-0109

TRACK MAINTENANCE (CONT'D)

Separation Of Embedded Metals (Cont'd)

Quick turns on bumpy and rocky fields should be avoided.

If abnormal wear of sprockets is observed, they should be immediately replaced.

Separation Of Embedded Metals Due To Corrosion

Damage:

Figure 30-30-10

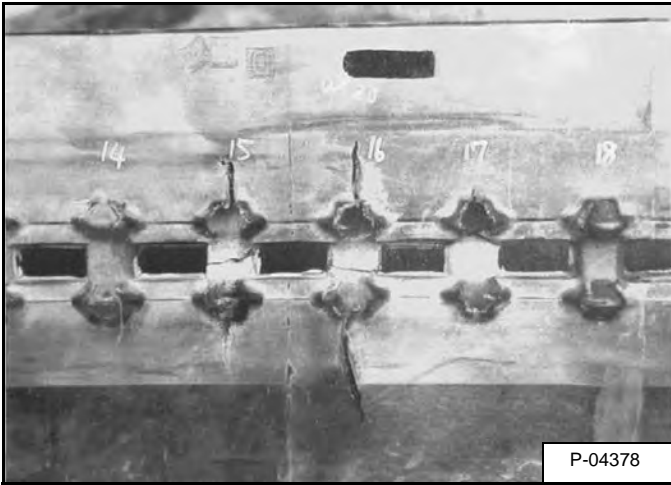

Due to corrosion of embedded metals, the adhesion to the rubber body deteriorates, resulting in complete separation [Figure 30-30-10].

Replacement:

Even a partial separation of embedded metals requires a rubber track replacement.

Causes Of The Damage

Figure 30-30-11

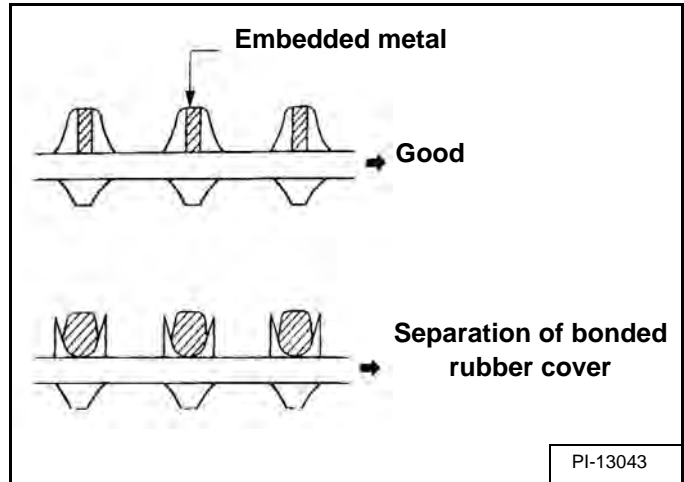

Embedded metals are bonded to the rubber body. The following operating conditions cause embedded metals to corrode, causing deterioration of the bonding, and finally resulting in separation of the embedded metals from the rubber body [Figure 30-30-11].

Excessively salty fields, like the sea shore.

Strong acidic or alkali soil conditions

Compost spread grounds

On tracks that are out of adjustment, the track rollers, idlers and sprockets will gradually wear the rubber surface at track roller side, causing exposure of the embedded metals. Consequently the embedded metals will corrode resulting in their separation from the rubber body.

Prevention:

If rubber tracks are used under such field conditions as described under (Causes Of The Damage), they should be washed with plenty of water. After being completely dried, they should be stored correctly.

When the bonded rubber cover is separated from the embedded metal projections and the metals in the rubber body become loose, it is time to consider replacement of the rubber track.



Bobcat®

ROPS CANOPY (CONT'D)

Removal And Installation (Cont'd)

Remove the upperstructure light. (See Cab Light Removal And Installation on Page 50-50-2.)

Figure 40-20-2

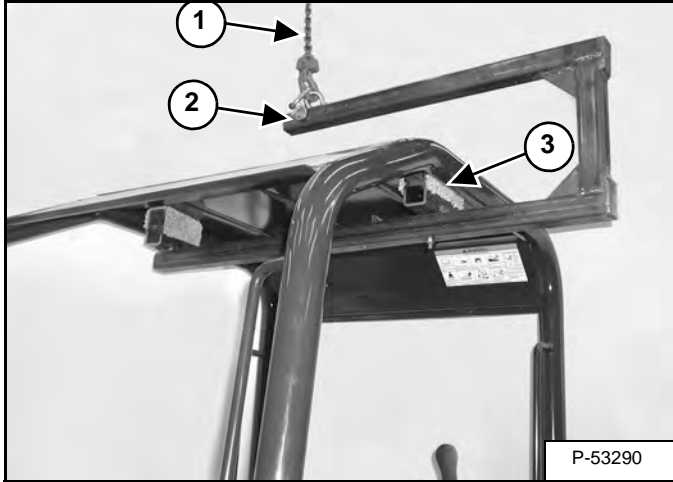

Install the chain hoist (Item 1) in the end hole of the lifting bracket (Item 2) [Figure 40-20-2].

Install the cab / canopy service lifting bracket on the cab [Figure 40-20-2].

NOTE: Use a lifting device of sufficient capacity.

Adjust the lifting bracket to the proper width by moving the bracket (Item 3) [Figure 40-20-2].

WARNING

Never use the cab / canopy service lifting bracket to lift the excavator. The bracket is not strong enough and can fail causing serious injury or death.

W-2384-1000

Figure 40-20-3

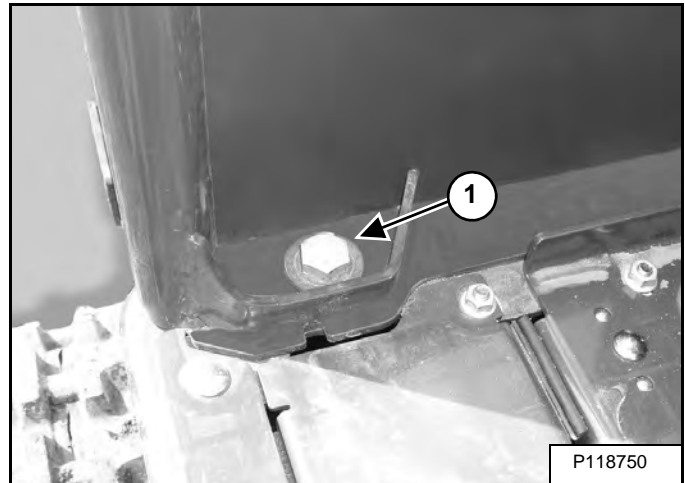
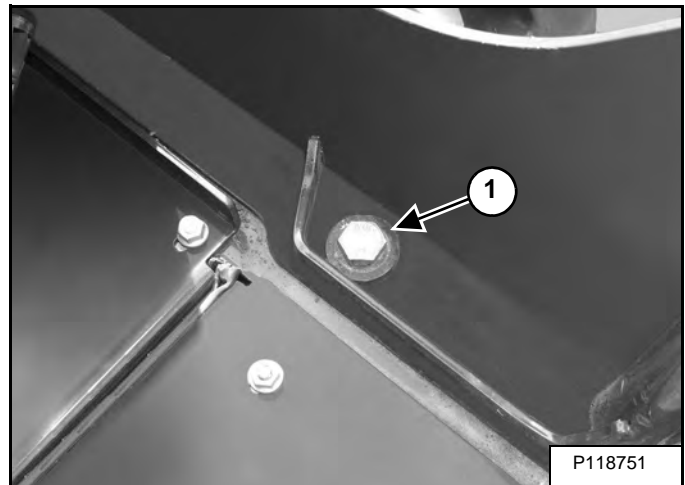

Figure 40-20-4



Remove the bolts, nuts and washers (Item 1) [Figure 40-20-3] and [Figure 40-20-4] from the front of the canopy.

Installation: Tighten the bolts to 160 - 180 N•m (118 - 133 ft-lb) torque.

CAB (CONT'D)

Front Window Removal And Installation (Cont'd)

Figure 40-30-20

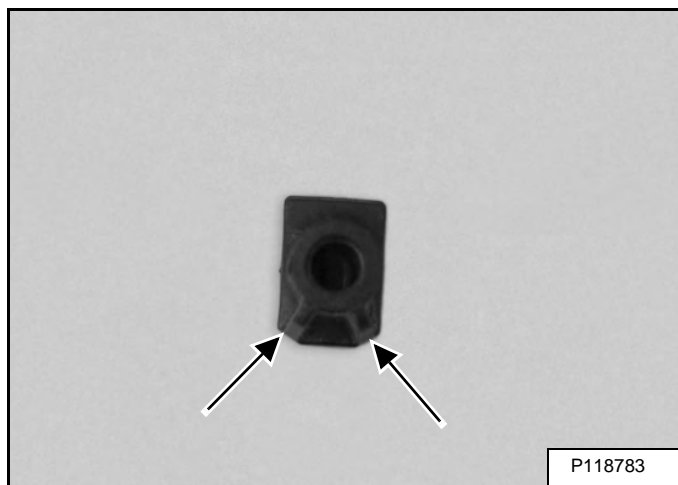

Installation: When installing the window check to see that the guide is positioned as shown. The pivot hole is offset and the ribs should be down [Figure 40-30-20].

LEFT CONSOLE (CONT'D)

Lock Lever Removal And Installation

Remove the gas spring. (See Gas Spring Removal And Installation on Page 40-50-3.)

Remove the console cover. (See Console Cover Removal And Installation on Page 40-50-1.)

Figure 40-50-9

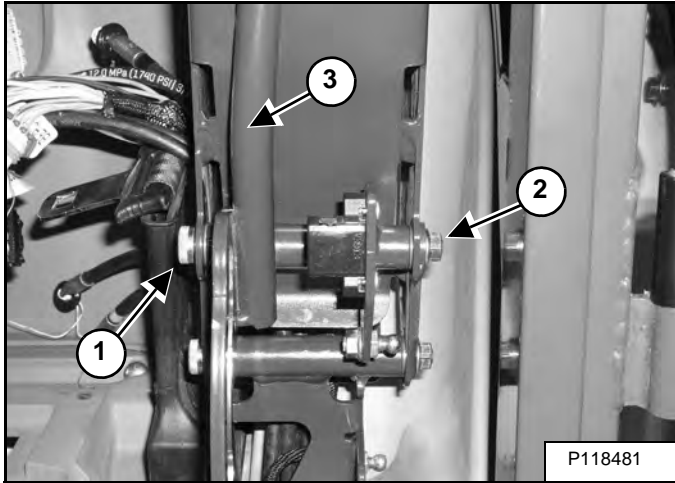

Remove the bolt (Item 1), nut (Item 2) and lever (Item 3) [Figure 40-50-9].

Installation: Apply thread adhesive (Loctite® 242) to the bolt threads.

Figure 40-50-10

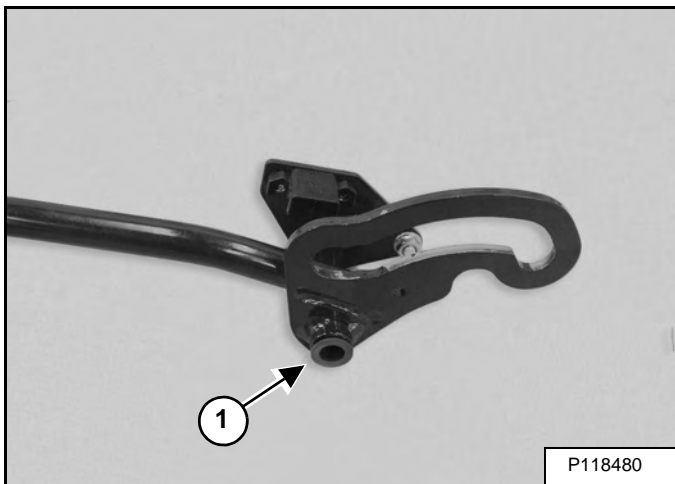

Remove the bushings (Item 1) [Figure 40-50-10] from both sides of the lever.

Console Removal And Installation

Remove the joystick. (See Removal and Installation on Page 20-111-4.)

Remove the lock lever. (See Lock Lever Removal And Installation on Page 40-50-4.)

Figure 40-50-11

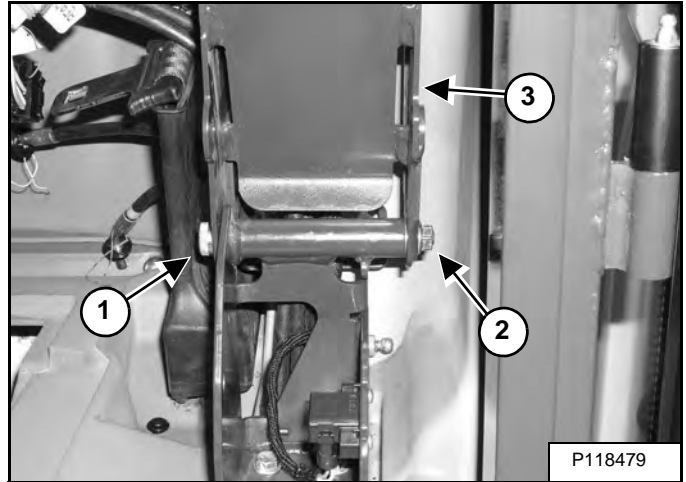

Remove the bolt (Item 1) and nut (Item 2). Remove the console (Item 3) [Figure 40-50-11] from the console base.

Figure 40-50-12

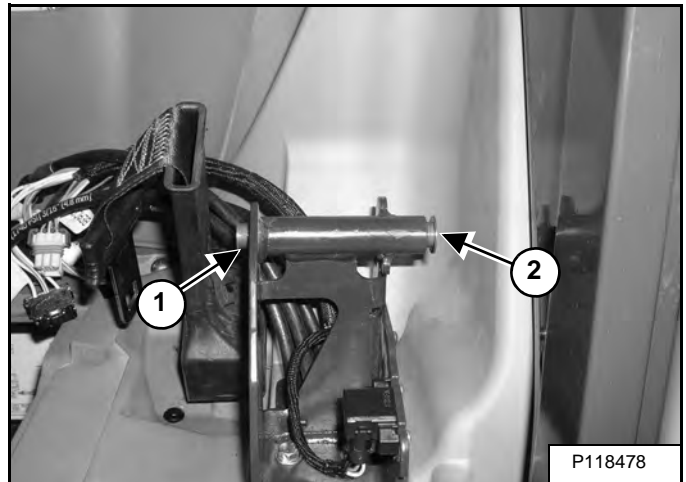

Remove the bushings (Item 1) [Figure 40-50-12] from the console base.

BLADE CONTROL (CONT'D)

Removal And Installation (Cont'd)

Figure 40-90-4

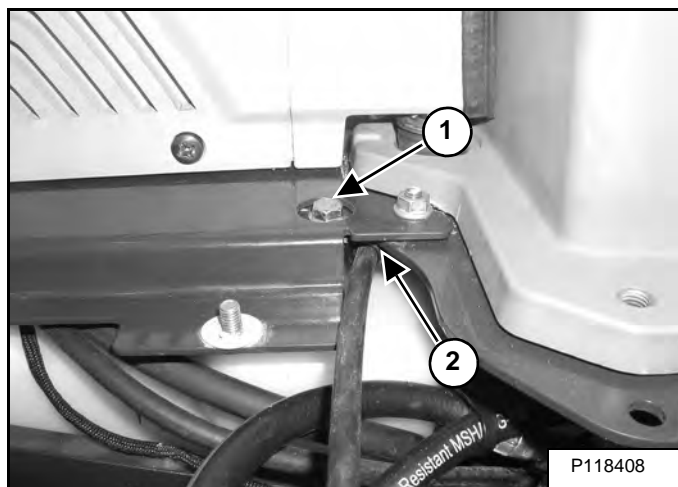

Remove the nut / bolt (Item 1) that is securing the cable clamp (Item 2) [Figure 40-90-4].

Remove the blade control assembly from the machine.

CONTROL LINKAGE ASSEMBLY (CONT'D)

Disassembly And Assembly

Figure 40-130-5

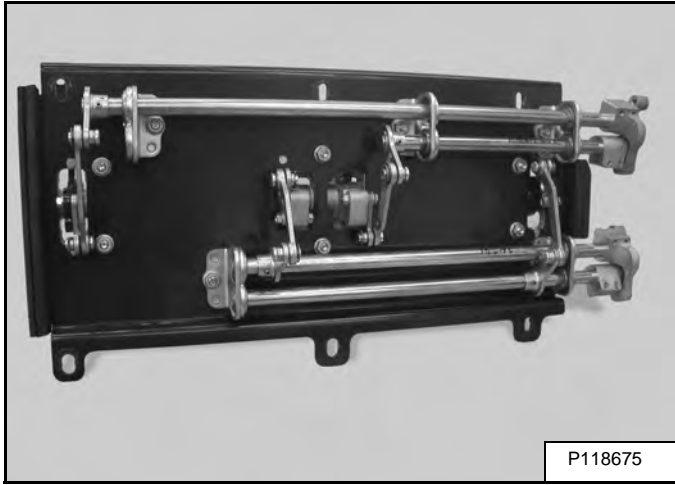

The control linkage assembly will have four linkage shafts if equipped with the manual boom swing and auxiliary pedals [Figure 40-130-5].

Figure 40-130-6

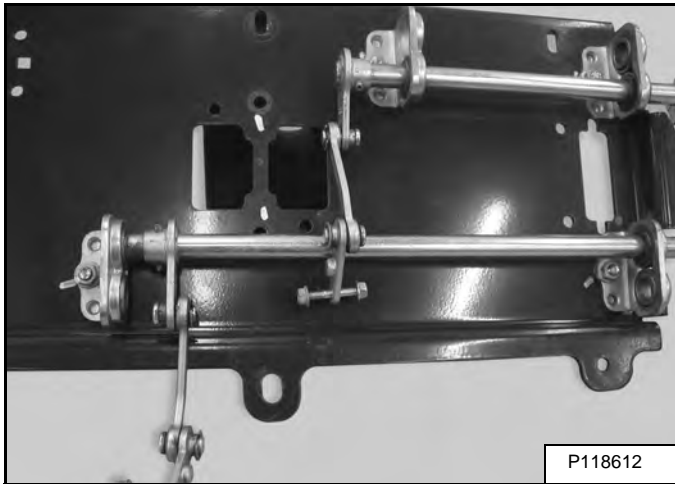

If equipped with the electric boom swing and auxiliary controls there are two linkage shafts [Figure 40-130-6].

The following procedure will cover the disassembly and assembly of one shaft. All of the components are the same on all the shafts.

Figure 40-130-7

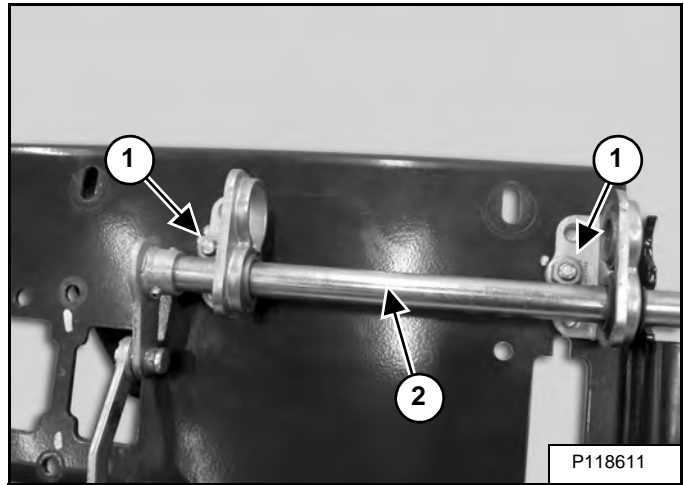

Remove the bolts (Item 1) from the mounting bracket to plate and remove the shaft assembly (Item 2) [Figure 40-130-7].

Figure 40-130-8

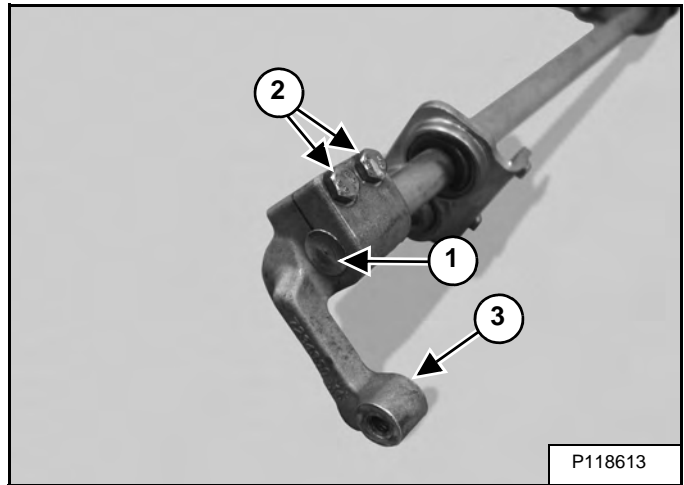

Mark the shaft and arm (Item 1) [Figure 40-130-8] for reference in assembly.

Loosen the bolts (Item 2) and remove the arm (Item 3) [Figure 40-130-8].

SWING FRAME (CONT'D)

Removal And Installation (Cont'd)

Figure 40-170-4

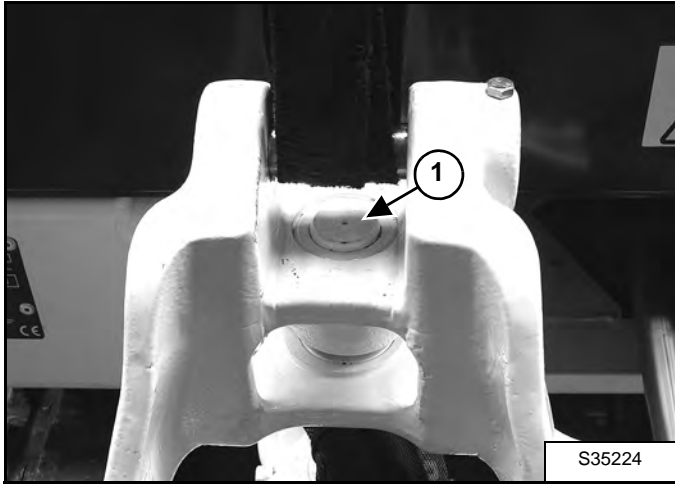

Remove the top pivot pin (Item 1) [Figure 40-170-3] from the swing frame.

Figure 40-170-5

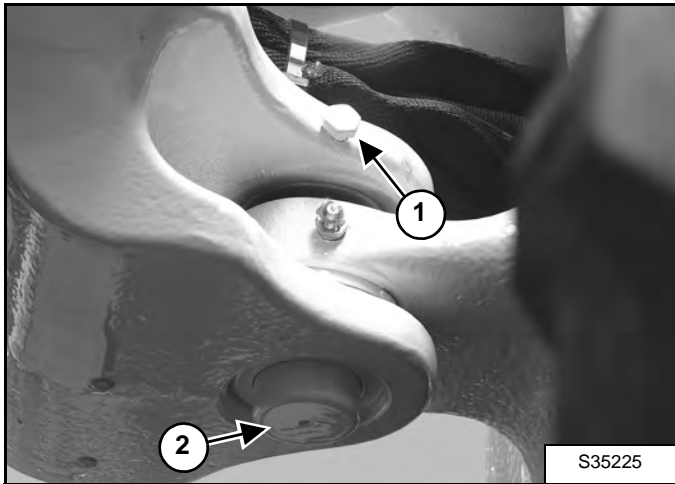

Remove the bolt and nuts (Item 1) [Figure 40-170-5] from the bottom pivot pin.

Remove the bottom pivot pin (Item 2) [Figure 40-170-5] from the swing frame.

Figure 40-170-6



Remove the swing frame from the excavator [Figure 40-170-6].



Bobcat®

OPERATOR BONNET (CONT'D)

Removal And Installation (Cont'd)

Figure 40-230-12

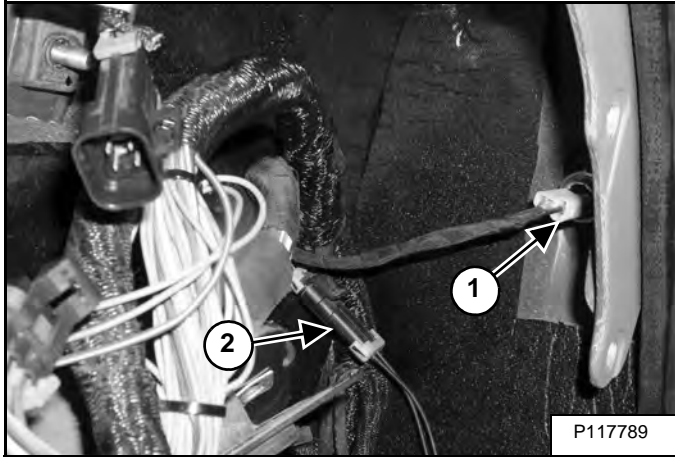

Disconnect the auxiliary power outlet wire harness (Item 1) and two speed wire harness (if equipped) (Item 2) [Figure 40-230-12].

Figure 40-230-13

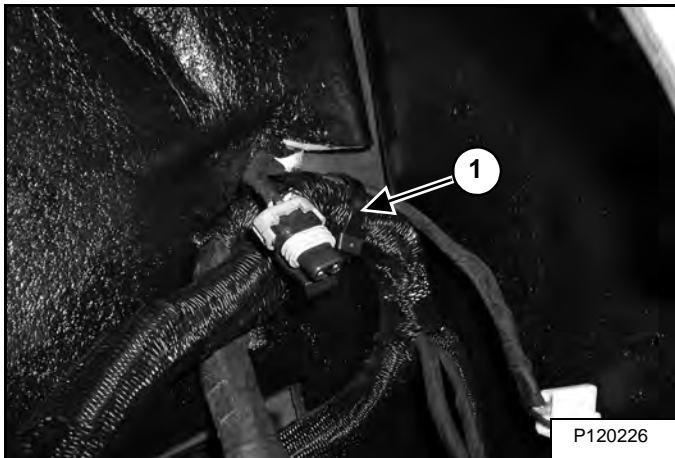

Cut and remove the cable tie (Item 1) [Figure 40-230-13].

Figure 40-230-14

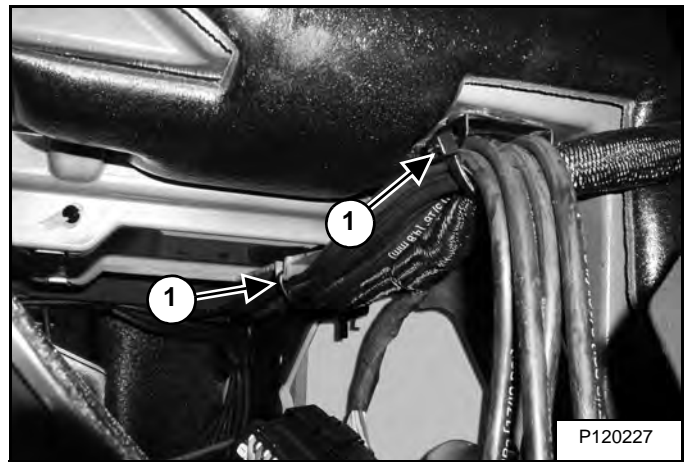

Cut and remove the cable ties (Item 1) [Figure 40-230-14].

Figure 40-230-15

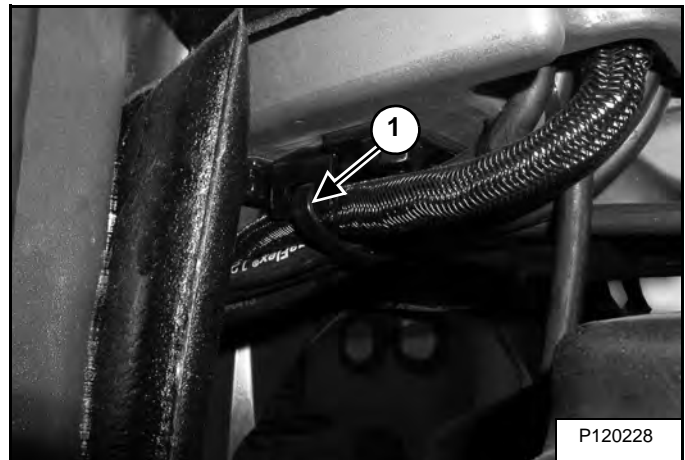

Cut and remove the cable tie (Item 1) [Figure 40-230-15].



Bobcat®

QUICK COUPLER (LEHNHOFF® SYSTEM) (CONT'D)

Disassembly (MS08) (Cont'd)

Figure 40-241-22

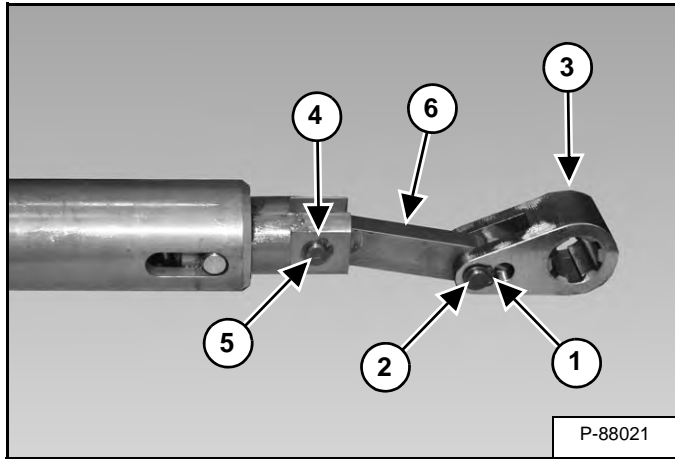

Remove the snap ring (Item 1) and pin (Item 2). Remove the driving fork (Item 3) [Figure 40-241-22].

Remove the snap ring (Item 4) and pin (Item 5). Remove the reversing lever (Item 6) [Figure 40-241-22].

Repeat the procedure for the other locking pin.

Figure 40-241-23

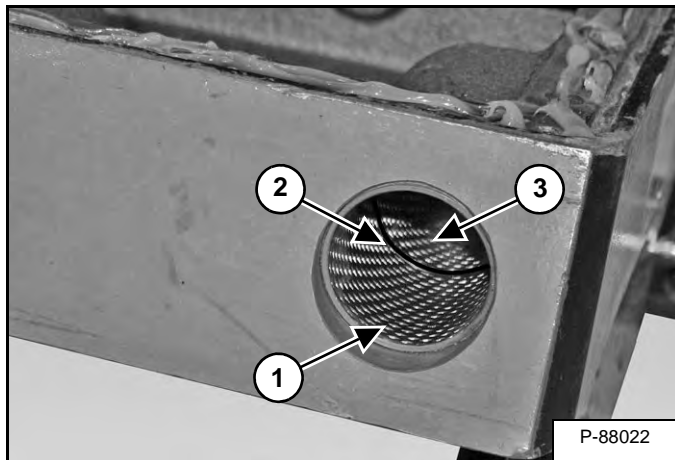

Remove the bushing (Item 1), O-ring (Item 2) and bushing (Item 3) [Figure 40-241-23] from both locking pin bores.

Assembly (MS08)

Figure 40-241-24

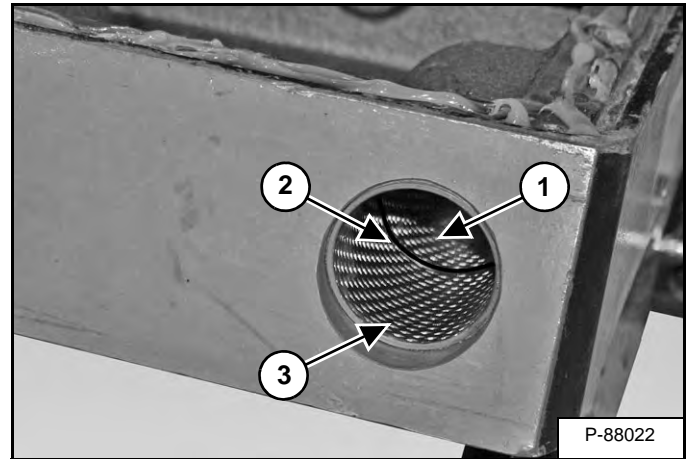

Install bushing (Item 1), O-ring (Item 2) and bushing (Item 3) [Figure 40-241-24] in both locking pin bores.

Figure 40-241-25

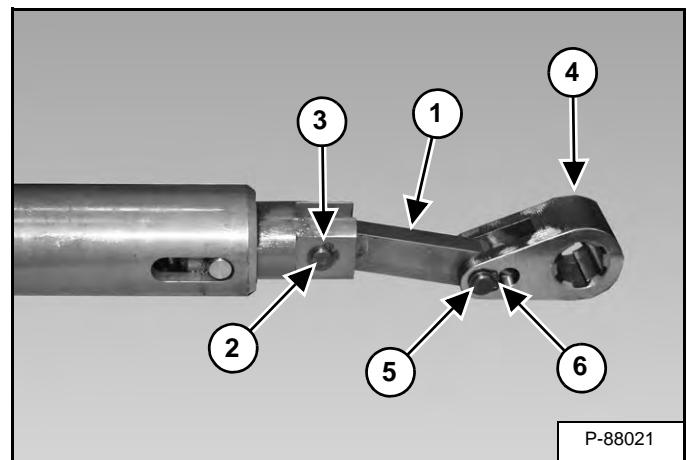

Install reversing lever (Item 1), pin (Item 2) and snap ring (Item 3) [Figure 40-241-25] on the locking pin.

Install the driving fork (Item 4), pin (Item 5) and snap ring (Item 6) [Figure 40-241-25] on the reversing lever. Repeat the procedure for the other locking pin.



Bobcat®

FRAME

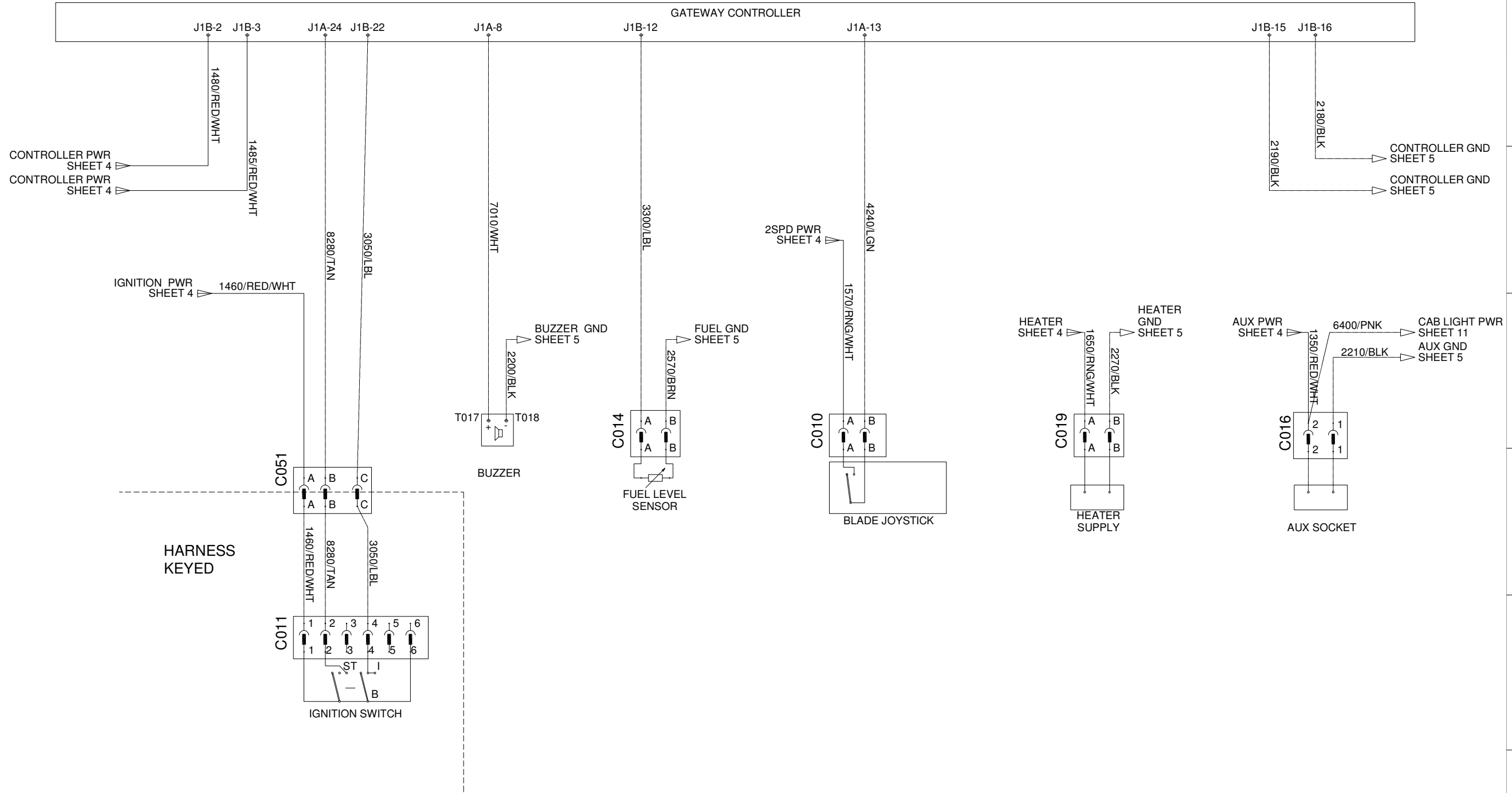

Wiring Schematic

E17

S/N B27H11001 & Above
 S/N B4PJ11001 & Above
 S/N B4PR11001 & Above

Printed On July 2020
 7258224 (A)
 Sheet 10 of 15

Printed In U.S.A.

[Printable Version Click Here](#)

ELECTRICAL SYSTEM INFORMATION (CONT'D)

Description

Figure 50-10-1

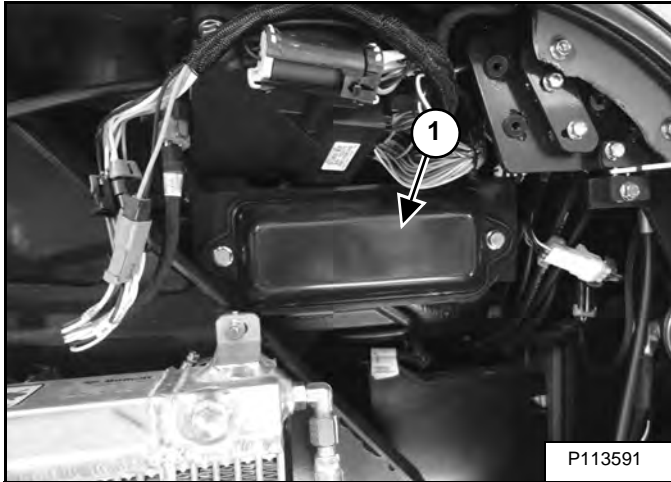

The excavator has a 12 volt, negative ground electrical system. The electrical system is protected by fuses located under the right side cover of the excavator (Item 1) [Figure 50-10-1]. The fuses will protect the electrical system when there is an electrical overload. The reason for the overload must be found and corrected before starting the engine again.

The battery cables must be clean and tight. Check the electrolyte level in the battery. Add distilled water as needed. Remove acid or corrosion from the battery and cables with a sodium bicarbonate and water solution.

Put Battery Saver P/N 6664458 or grease on the battery terminals and cable ends to prevent corrosion.

WARNING

AVOID INJURY OR DEATH

Batteries contain acid which burns eyes and skin on contact. Wear goggles, protective clothing and rubber gloves to keep acid off body.

In case of acid contact, wash immediately with water. In case of eye contact get prompt medical attention and wash eye with clean, cool water for at least 15 minutes.

If electrolyte is taken internally drink large quantities of water or milk! DO NOT induce vomiting. Get prompt medical attention.

W-2065-0807

Fuse And Relay Location / Identification

A decal is inside the fuse cover to show location and amp ratings.

Remove the cover to check or replace the fuses and relays.

The location and sizes are shown in [Figure 50-10-2].

Always replace fuses using the same type and capacity.

ALTERNATOR (CONT'D)

Parts Identification

- | | |
|----------------|-----------------|
| 1. Alternator | 15. Nut |
| 2. Frame Assy. | 16. Insulator |
| 3. Plate | 17. Bolt |
| 4. Screw | 18. Screw |
| 5. Bearing | 19. Nut |
| 6. Stud | 20. Nut |
| 7. Frame End | 21. Rotor Assy. |
| 8. Holder | 22. Bearing |
| 9. Holder | 23. Cover |
| 10. Seal | 24. Pulley |
| 11. Brush | 25. Spacer |
| 12. Spring | 26. Bolt |
| 13. Regulator | 27. Screw |
| 14. Cover | 28. Screw |

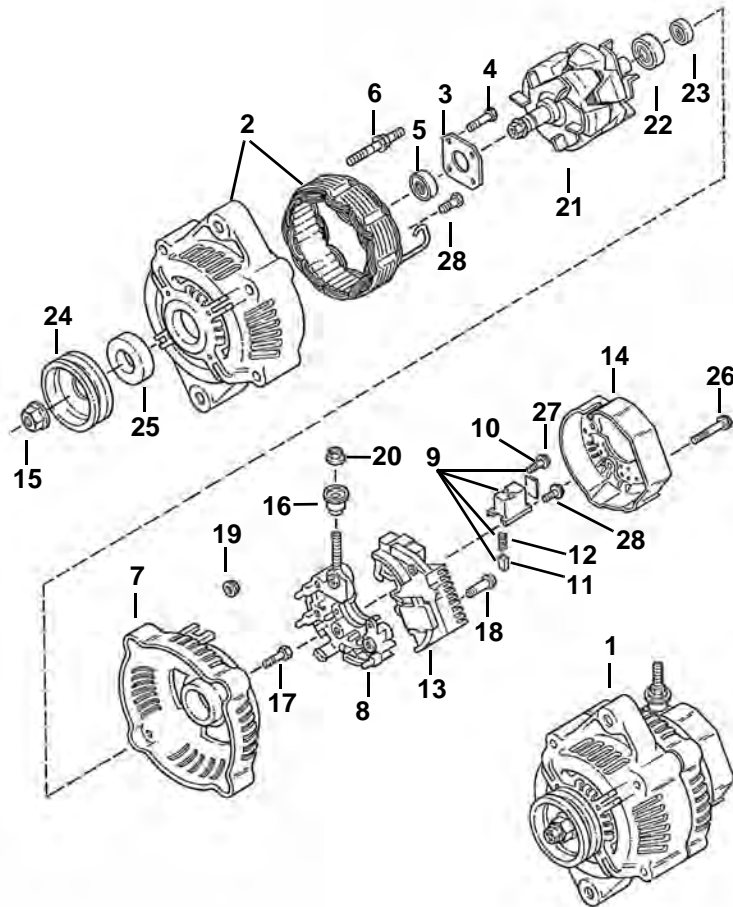

C-3456

TWO-SPEED SWITCH

Removal And Installation

Figure 50-70-1

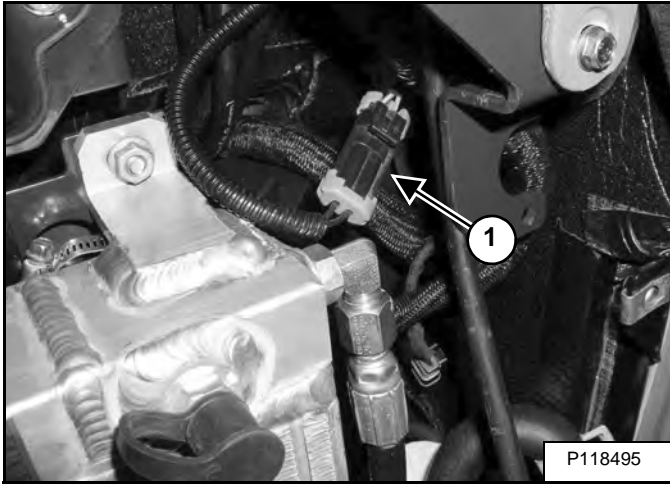

Open the right side cover and disconnect the wire harness (Item 1) [Figure 50-70-1].

Figure 50-70-2

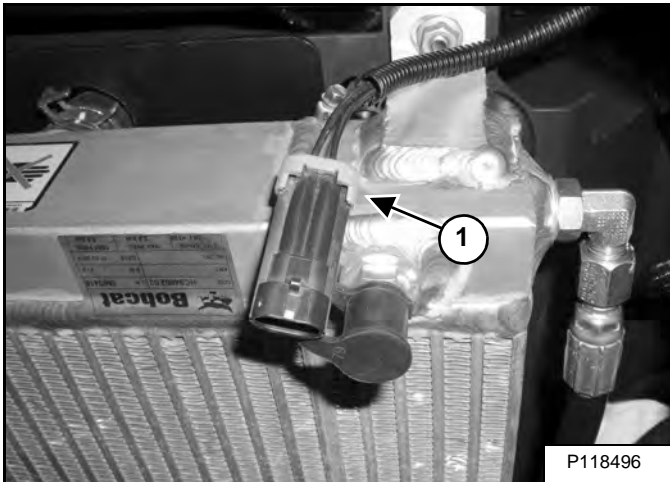

Remove the lock (Item 1) [Figure 50-70-2] from electrical connector.

Using a small piece of wire, depress the wire terminal tabs.

Carefully remove the individual wires from the back of the electrical connector.

A	Red
B	Green

Installation: Check each wire to be certain it locks into place.

Figure 50-70-3

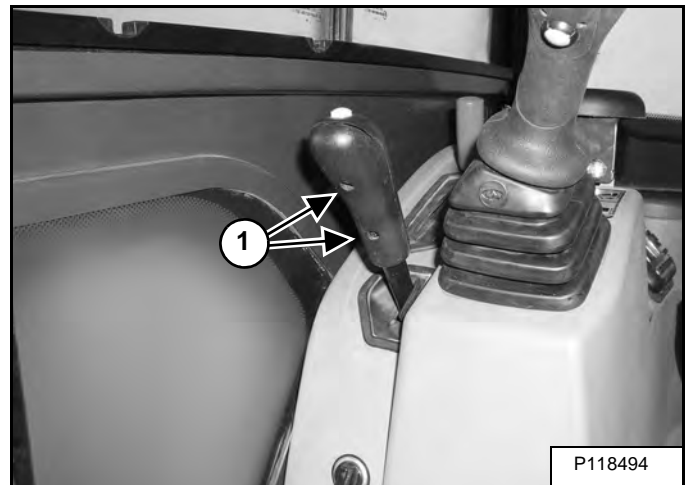

Remove the screws (Item 1) [Figure 50-70-3] from the blade handle.

Figure 50-70-4

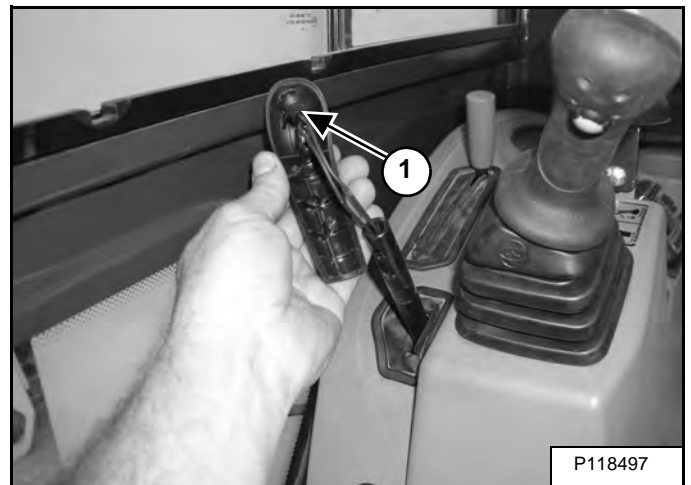

Remove the two speed switch (Item 1) [Figure 50-70-4] and wire harness from the blade handle.

ENGINE INFORMATION

Description

The E17 Bobcat Excavator has a Kubota® direct injected D722-E2B diesel engine with a displacement of 0,719 L (43.88 in³). The engine is rated at 9,9 kWh (13.3 hp) and has a closed crankcase ventilation system.

The engine has three cylinders and the rotation is counter-clockwise (viewed from the flywheel side). Engine block heaters are also available from Bobcat Parts.

The engine serial number is stamped on the engine and is located near the injection pump. The model number is located on the valve cover. Use these numbers to obtain the correct service parts.

The engine is liquid cooled with a propylene glycol / water mixture. The cooling fan is belt driven. The speed of the fan is determined by the engine speed.

ENGINE INFORMATION (CONT'D)

Removal And Installation (Cont'd)

Figure 60-10-7

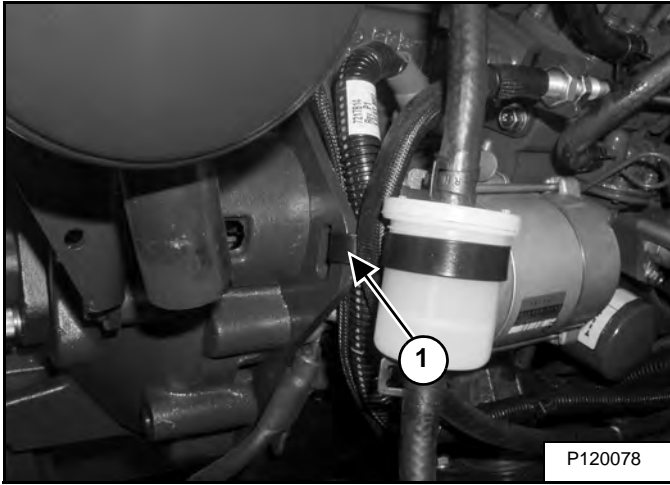

Remove the cable tie (Item 1) [Figure 60-10-7].

Figure 60-10-8

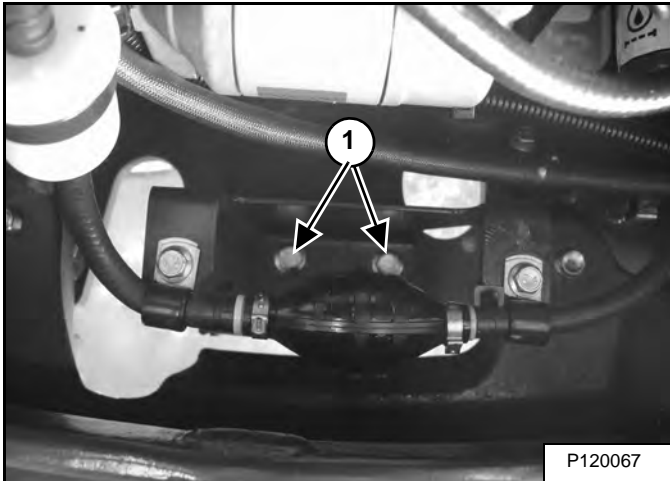

Remove the two bolts (Item 1) [Figure 60-10-8] and set the fuel primer pump bracket to the side.

Figure 60-10-9

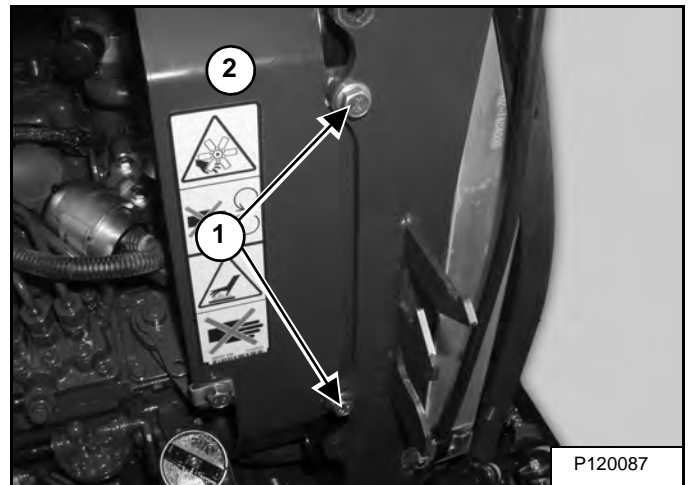

Remove the bolts (Item 1) and the cover (Item 2) [Figure 60-10-9].

Figure 60-10-10

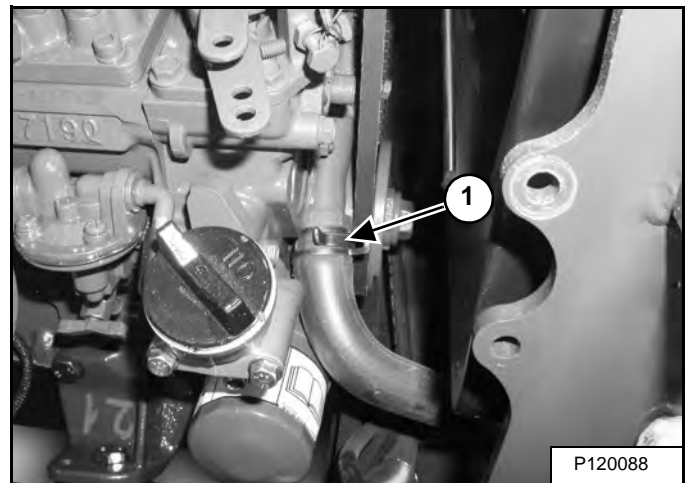

Remove the lower radiator hose (Item 1) [Figure 60-10-10].

ENGINE COOLING SYSTEM

Radiator / Oil Cooler Removal And Installation

! WARNING

AVOID INJURY OR DEATH

Wear safety glasses to prevent eye injury when any of the following conditions exist:

- When fluids are under pressure.
- Flying debris or loose material is present.
- Engine is running.
- Tools are being used.

W-2019-0907

IMPORTANT

When repairing hydrostatic and hydraulic systems, clean the work area before disassembly and keep all parts clean. Always use caps and plugs on hoses, tubelines and ports to keep dirt out. Dirt can quickly damage the system.

I-2003-0888

IMPORTANT

Fluid such as engine oil, hydraulic fluid, coolants, grease, etc. must be disposed of in an environmentally safe manner. Some regulations require that certain spills and leaks on the ground must be cleaned in a specific manner. See local, state and federal regulations for the correct disposal.

I-2067-0499

IMPORTANT

Contain and dispose of any oil leakage in an environmentally safe manner.

I-2066-0395

Remove the right upperstructure cover. (See Removal And Installation on Page 40-70-1.)

Drain the hydraulic fluid. (See Removing And Replacing The Hydraulic Fluid on Page 10-120-3.)

Drain the engine coolant. (See Removing And Replacing Coolant on Page 10-90-3.)

Open the right side cover.

Figure 60-40-1

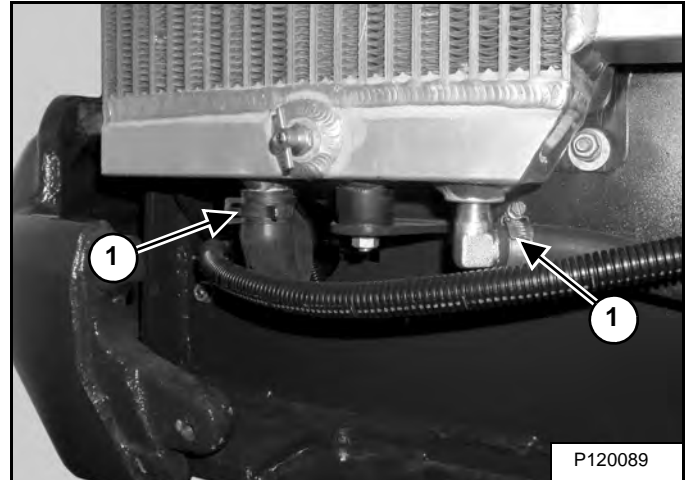

Disconnect the hoses (Item 1) [Figure 60-40-1].

Figure 60-40-2

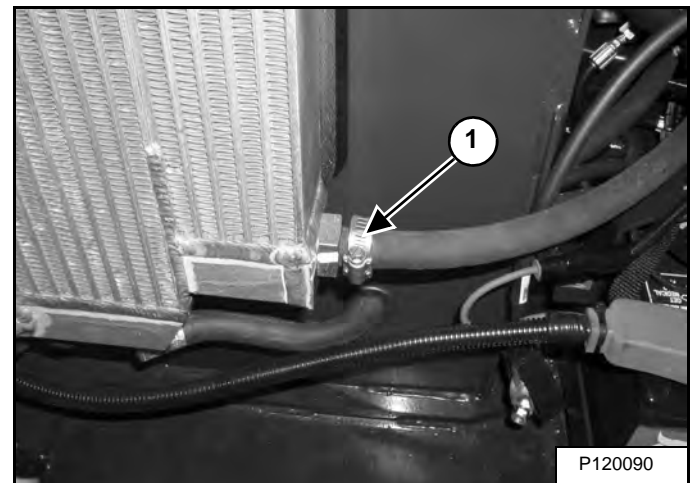

Disconnect the hose (Item 1) [Figure 60-40-2].

FUEL SYSTEM

Fuel Shutoff Solenoid Removal And Installation

Open the tailgate.

Figure 60-60-1

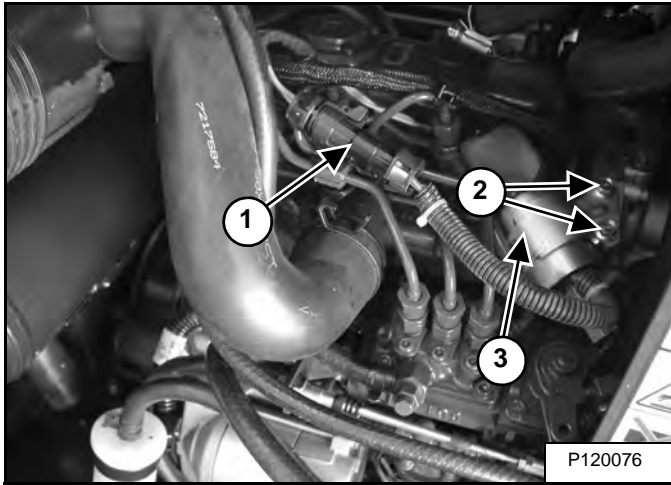

Disconnect the wire harness from the solenoid (Item 1) **[Figure 60-60-1]**.

Remove the solenoid mounting bolts (Item 2) **[Figure 60-60-1]**.

Remove the solenoid (Item 3) **[Figure 60-60-1]**.

Hydraulic filter mount and fuel filter mount removed for photo clarity.

CYLINDER HEAD

Glow Plug Removal And Installation

IMPORTANT

Do not bend the high pressure fuel injection tubes when removing or installing them.

I-2029-0289

Remove the tool box. (See Removal And Installation on Page 40-260-1.)

Figure 60-70-1

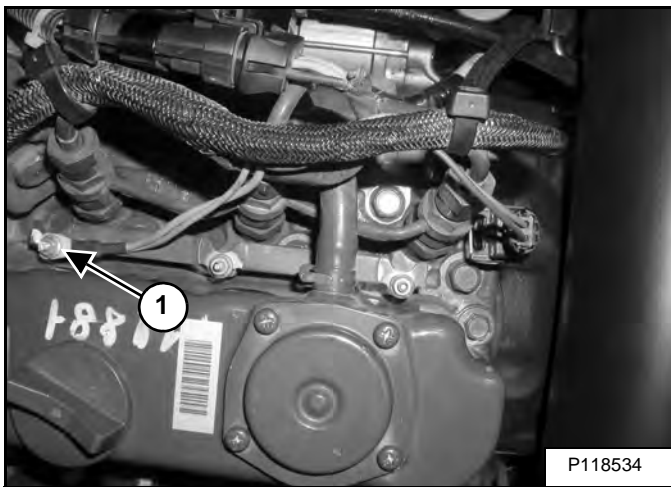

Remove the glow plug lead (Item 1) [Figure 60-70-1].

Figure 60-70-2

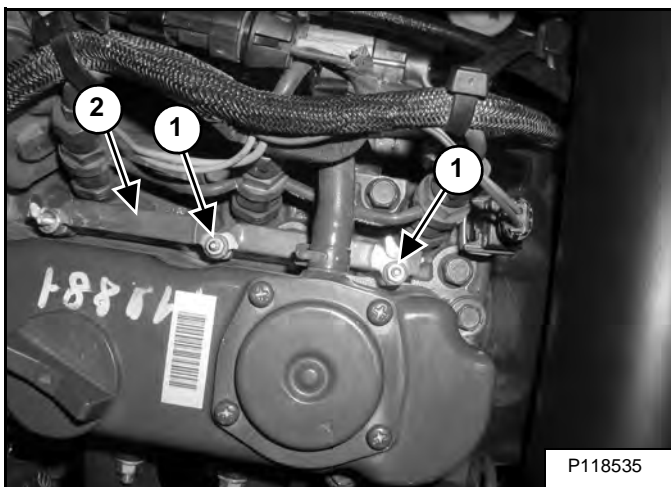

Remove the nuts (Item 1) [Figure 60-70-2].

Remove the glow plug connector (Item 2) [Figure 60-70-2].

Figure 60-70-3

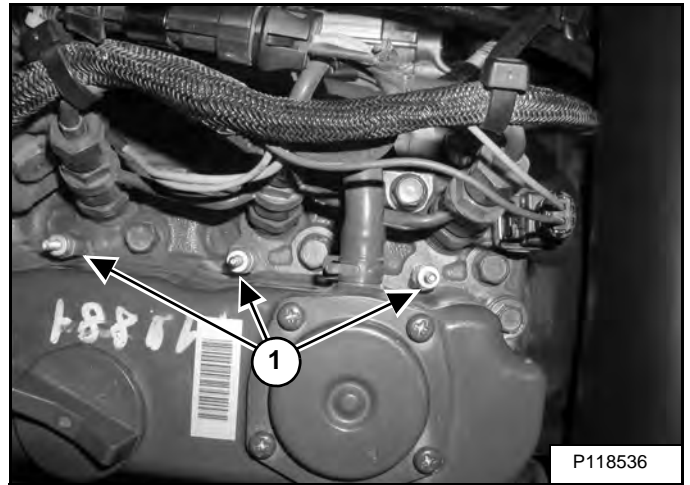

Remove the glow plugs (Item 1) [Figure 60-70-3] from the cylinder head.

Installation: Tighten the glow plugs to 8 - 15 N•m (6 - 11 ft-lb) torque.

Figure 60-70-4

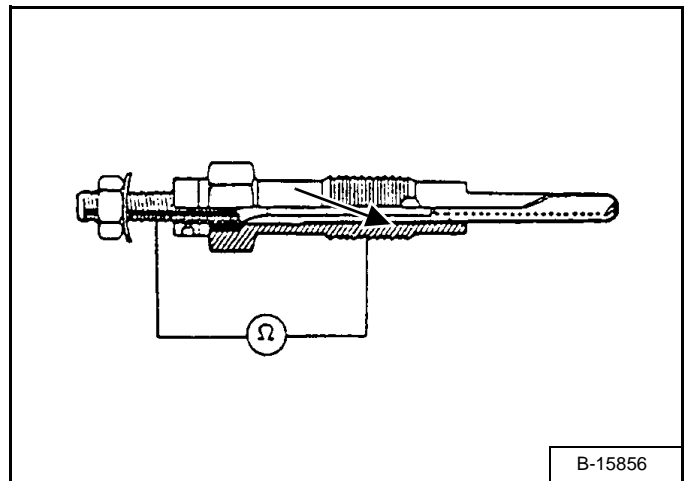

Connect an ohmmeter to the terminal end of the glow plug, touch the other lead from the ohmmeter to the heating end of the glow plug [Figure 60-70-4].

The reading will be approximately 0.9 ohm. If the resistance is 0 ohm, the glow plug has a short circuit. If the resistance is infinite, the coil of the glow plug is broken.

CYLINDER HEAD (CONT'D)

Valve Tappets

Figure 60-70-30

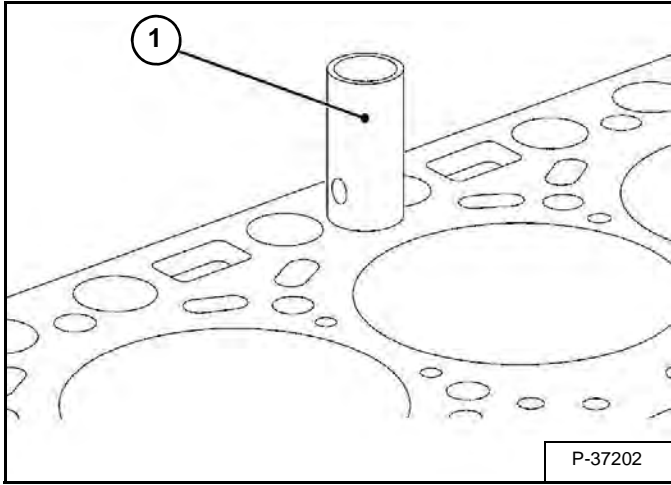

Remove the tappets (Item 1) [Figure 60-70-30] from the crankcase.

When reassembling replace the head gasket with a new one.

Before installing the tappets (Item 1) [Figure 60-70-30], apply engine oil thinly around them.

NOTE: Mark the cylinder number to the tappets to prevent interchanging.

Figure 60-70-31

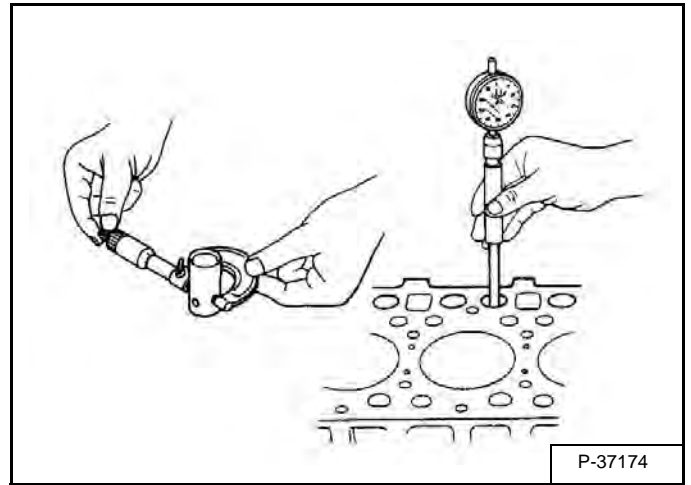

Measure the tappet O.D. with an outside micrometer [Figure 60-70-31].

Measure the I.D. of the tappet guide bore with a cylinder bore gauge, and calculate the oil clearance [Figure 60-70-31].

If the oil clearance exceeds the allowable limit or the tappet is damaged, replace the tappet.

Oil clearance between tappet and guide	Factory spec.	0,016 - 0,052 mm (0.00063 - 0.00205 in)
	Allowable limit	0,10 mm (0.0039 in)

Tappet O.D.	Factory spec.	17,966 - 17,984 mm (0.70732 - 0.70803 in)
Tappet guide I.D.	Factory spec.	18,000 - 18,018 mm (0.70866 - 0.70937 in)

CRANKSHAFT AND PISTONS (CONT'D)

Crankshaft And Bearings Removal And Installation (Cont'd)

Figure 60-80-22

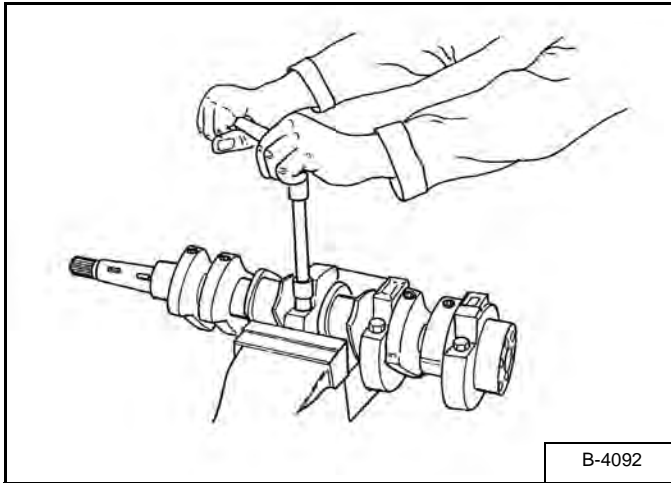

Remove the two bearing case bolts [Figure 60-80-22].

Remove the bearing case and bearing.

Installation: Tighten the bearing case bolts (Item 1) [Figure 60-80-23] to 13 - 16 N•m (9 - 12 ft-lb) torque.

Figure 60-80-23

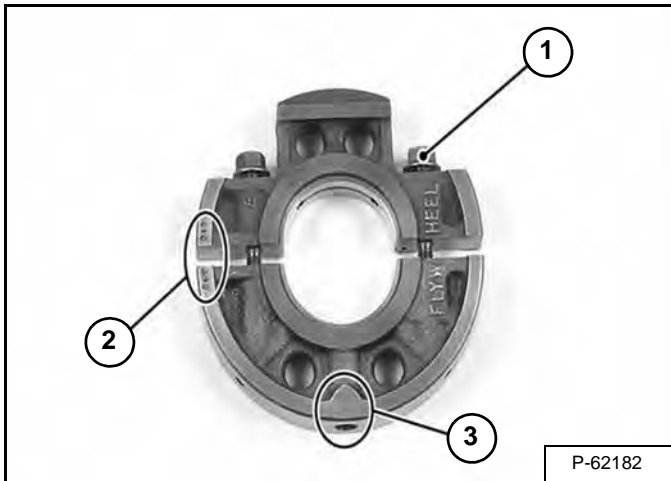

Installation: When installing the main bearing case assemblies, face the mark FLYWHEEL to the flywheel side of the engine block [Figure 60-80-23]. Be sure the thrust washer with its oil grooves face outward.

Identification marks on the main bearing case assemblies are the alignment number (Item 2) and the marking "1" or "2" (Item 3) [Figure 60-80-23] can be found on the main bearing case assemblies to ensure proper assembly.

Crankshaft And Bearings - Servicing

Figure 60-80-24

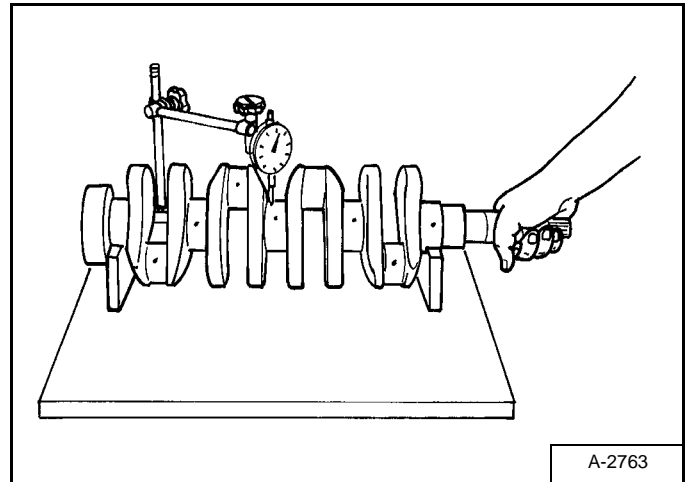

Put the crankshaft on V-blocks. Install a dial indicator on the center journal [Figure 60-80-24].

Turn the crankshaft at a slow rate.

If the misalignment exceeds the allowable limit, replace the crankshaft.

Alignment 0,02 mm (0.0008 in)

Tighten the connecting rod cap bolts 27 - 30 N•m (20 - 22 ft-lb) torque.

Figure 60-80-25

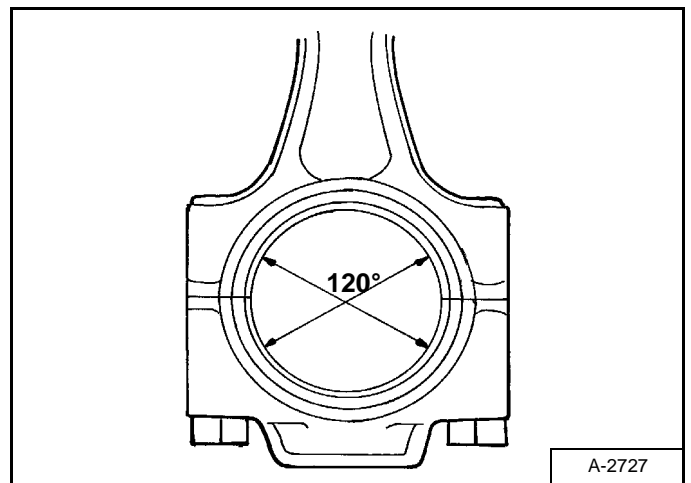

Measure the crankpin bearing I.D. [Figure 60-80-25].

FLYWHEEL AND HOUSING

Flywheel Housing Removal And Installation

Drain the hydraulic reservoir. (See Removing And Replacing The Hydraulic Fluid on Page 10-120-3.)

Remove the hydraulic pump. (See Removal And Installation on Page 20-50-4.)

Remove the spark arrester muffler. (See Removal And Installation on Page 60-20-1.)

Remove the starter. (See Removal And Installation on Page 50-40-2.)

Figure 60-100-1

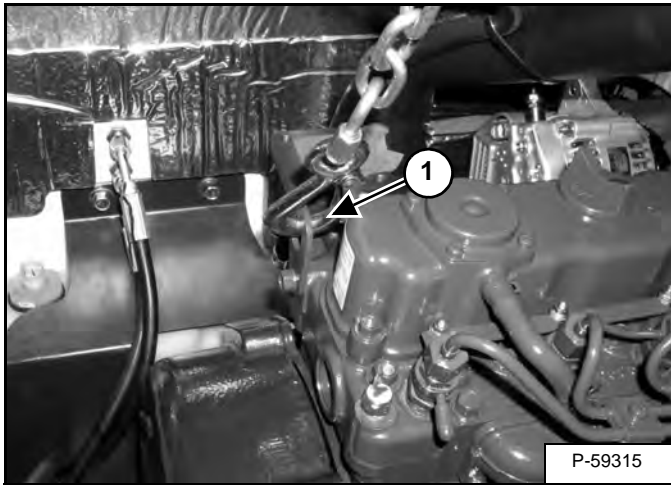

Install a chain hoist to the engine lifting eye to support the engine (Item 1) [Figure 60-100-1].

Figure 60-100-2

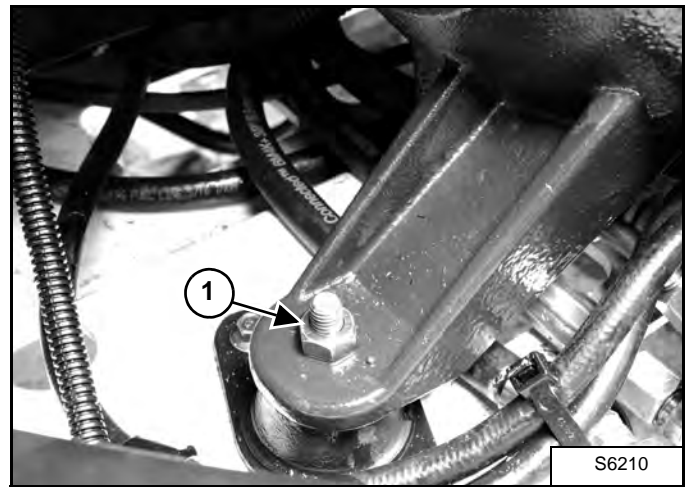

Remove the mount bolt and nut (Item 1) [Figure 60-100-2] from the engine mount.

Installation: Tighten the bolt and nut to 43 - 47 N•m (32 - 35 ft-lb) torque.

Figure 60-100-3

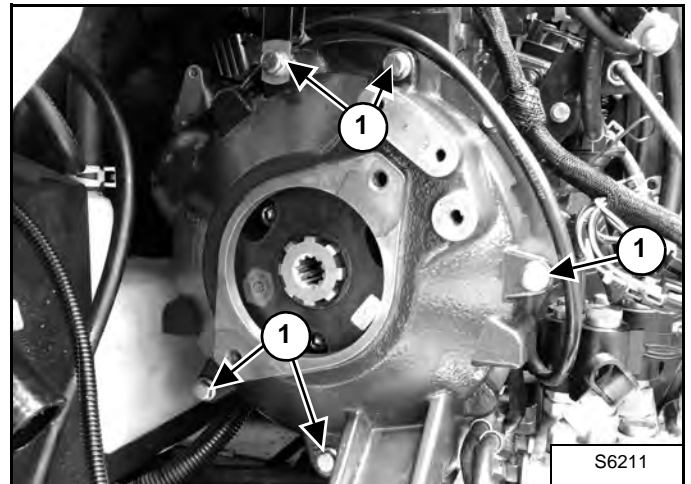

Remove the five flywheel housing bolts (Item 1) [Figure 60-100-3].

Installation: Tighten the bolts to 24 - 26 N•m (18 - 19 ft-lb) torque.

Remove the flywheel housing.

NOTE: Check that the alignment dowel pins are installed in the flywheel housing for assembly.

HEATER UNIT

Removal And Installation

Drain the engine coolant. (See Removing And Replacing Coolant on Page 10-90-3.)

Remove the floor mats. (See Removal And Installation on Page 40-140-1.)

Figure 70-30-1



Remove the rear cover of heater unit (Item 1) [Figure 70-30-1].

Figure 70-30-2

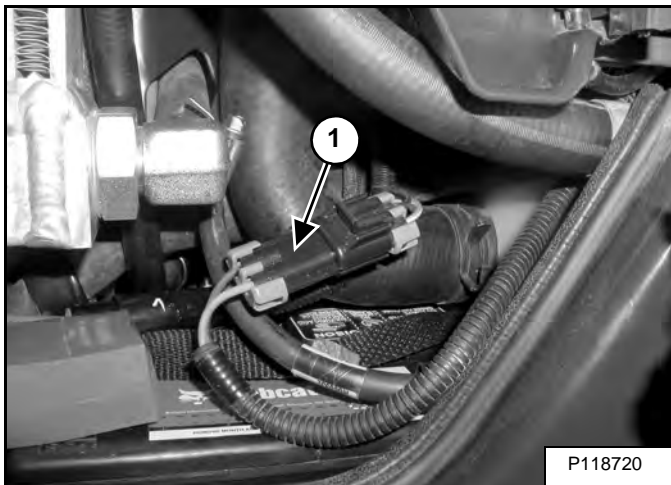

Disconnect the fan switch harness (Item 1) [Figure 70-30-2].

Figure 70-30-3

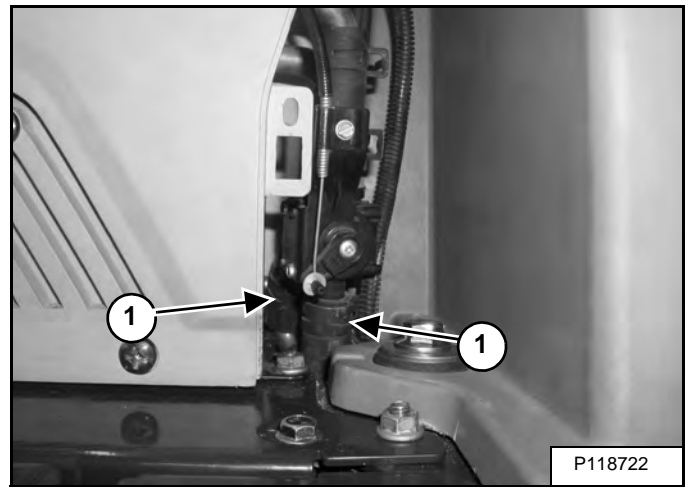

Remove the two clamps (Item 1) [Figure 70-30-3] for the heater hoses.

Figure 70-30-4

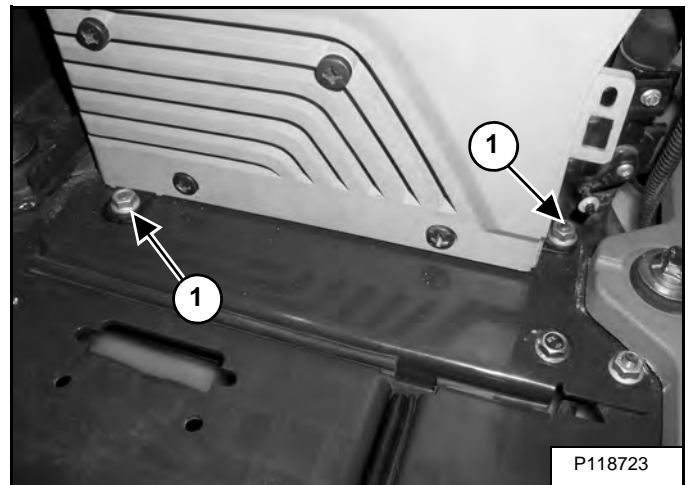

Remove the two mounting nuts (Item 1) [Figure 70-30-4].

SPECIFICATIONS

EXCAVATOR SPECIFICATIONS	SPEC-10-1
Machine Dimensions	SPEC-10-1
Performance	SPEC-10-3
Controls	SPEC-10-3
Engine	SPEC-10-4
Hydraulic System	SPEC-10-4
Hydraulic Cylinders	SPEC-10-5
Hydraulic Cycle Times	SPEC-10-5
Electrical	SPEC-10-5
Drive System	SPEC-10-5
Slew System	SPEC-10-6
Undercarriage	SPEC-10-6
Capacities	SPEC-10-6
Tracks	SPEC-10-6
Ground Pressure	SPEC-10-6
Environmental	SPEC-10-7
Temperature Range	SPEC-10-7
TECHNICAL SERVICE GUIDE SPECIFICATIONS	SPEC-20-1
Engine	SPEC-20-1
Engine Torques	SPEC-20-1
Cooling System	SPEC-20-1
Excavator Torques	SPEC-20-1
TORQUE SPECIFICATIONS FOR BOLTS	SPEC-30-1
Torque For General SAE Bolts	SPEC-30-1
Torque For General Metric Bolts	SPEC-30-2
HYDRAULIC CONNECTION SPECIFICATIONS	SPEC-40-1
O-ring Face Seal Connection	SPEC-40-1
Straight Thread O-ring Fitting	SPEC-40-2
Tubelines And Hoses	SPEC-40-2
Flare Fitting	SPEC-40-3
Port Seal Fitting	SPEC-40-4
HYDRAULIC FLUID SPECIFICATIONS	SPEC-50-1
Specifications	SPEC-50-1
CONVERSIONS	SPEC-60-1
Decimal And Millimeter Equivalent Chart	SPEC-60-1
U.S. To Metric Conversion Chart	SPEC-60-1

TECHNICAL SERVICE GUIDE SPECIFICATIONS

Engine

Engine Oil Pressure at Low Idle	49 kPa (49 bar) (7.1 psi)
Engine Oil Pressure at High Idle	197 - 441 kPa (1,97 - 4,41 bar) (28.5 - 64 psi)
Location of Number 1 Cylinder	Closest to water pump
Crankshaft Rotation (Facing Crankshaft Pulley)	Clockwise
Valve Clearance (Cold) Intake	145 - 185 mm (.005 - .007 in)
Valve Clearance (Cold) Exhaust	145 - 185 mm (.005 - .007 in)

NOTE: For additional engine specifications, (See Specifications on Page 60-10-2.)

Engine Torques

Fuel Injection Tubeline Nuts	29,4 N•m (21.7 ft-lb)
Glow Plugs	8 - 14 N•m (5.8 - 10 ft-lb)
Injection Pump Mounting Nuts	22 N•m (16 ft-lb)
Valve Cover Bolts	9 - 11 N•m (7.3 - 8.4 ft-lb)
Head Bolts	38 - 42 N•m (28 - 31 ft-lb)

NOTE: For additional engine torques, (See Torque Values on Page 60-10-7.)

Cooling System

Coolant Type and Mix	47% Water and 53% Propylene Glycol
Radiator Cap Pressure	89 kPa (0,9 bar) (13 psi)
Thermostat	Fully Open at 85°C (185°F)

NOTE: For additional cooling system information, (See ENGINE COOLING SYSTEM on Page 60-40-1.)

Excavator Torques

Drive Motor To Frame Bolt	40 - 50 N•m (29 - 37 ft-lb)
Sprocket To Drive Motor	65 - 75 N•m (48 - 55 ft-lb)
Swing Bearing To Frame Bolt	105 - 115 N•m (78 - 85 ft-lb)
Swing Bearing To Upperstructure Bolt	105 - 115 N•m (78 - 85 ft-lb)
Swing Motor Mounting Bolts	115 N•m (85 ft-lb)
Swivel Joint Mounting Bolts	105 - 115 N•m (78 - 85 ft-lb)

CONVERSIONS

Decimal And Millimeter Equivalent Chart

FRACTIONS	DECIMALS	MM	FRACTIONS	DECIMALS	MM
	1/64 —	0.015625 —	0.397		
1/32 —	0.03125 —	0.794		33/64 —	0.515625 —
	3/64 —	0.046875 —	1.191	17/32 —	0.53125 —
1/16 —	0.0625 —	1.588		35/64 —	0.546875 —
	5/64 —	0.078125 —	1.984	9/16 —	0.5625 —
3/32 —	0.09375 —	2.381		37/64 —	0.578125 —
	7/64 —	0.109375 —	2.778	19/32 —	0.59375 —
1/8 —	0.1250 —	3.175		39/64 —	0.609375 —
	9/64 —	0.140625 —	3.572	5/8 —	0.6250 —
5/32 —	0.15625 —	3.969		41/64 —	0.640625 —
	11/64 —	0.171875 —	4.366	21/32 —	0.65625 —
3/16 —	0.1876 —	4.762		43/64 —	0.671875 —
	13/64 —	0.203125 —	5.159	11/16 —	0.6875 —
7/32 —	0.21875 —	5.556		45/64 —	0.703125 —
	15/64 —	0.234375 —	5.953	23/32 —	0.71875 —
1/4 —	0.2500 —	6.350		47/64 —	0.734375 —
	17/64 —	0.265625 —	6.747	3/4 —	0.7500 —
9/32 —	0.28125 —	7.144		49/64 —	0.765625 —
	19/64 —	0.296875 —	7.541	25/32 —	0.78125 —
5/16 —	0.3125 —	7.938		51/64 —	0.796875 —
	21/64 —	0.328125 —	8.334	13/16 —	0.8125 —
11/32 —	0.34375 —	8.731		53/64 —	0.828125 —
	23/64 —	0.359375 —	9.128	27/32 —	0.84375 —
3/8 —	0.3750 —	9.525		55/64 —	0.859375 —
	25/64 —	0.390625 —	9.922	7/8 —	0.8750 —
13/32 —	0.40625 —	10.319		57/64 —	0.890625 —
	27/64 —	0.421875 —	10.716	29/32 —	0.90625 —
7/16 —	0.4375 —	11.112		59/64 —	0.921875 —
	29/64 —	0.453125 —	11.509	15/16 —	0.9375 —
15/32 —	0.46875 —	11.906		61/64 —	0.953125 —
	31/64 —	0.484375 —	12.303	31/32 —	0.96875 —
1/2 —	0.5000 —	12.700		63/64 —	0.984375 —
				1 —	1.000 —

1 mm = 0.03937"

0.001 = 0.0254 mm

U.S. To Metric Conversion Chart

	TO CONVERT	INTO	MULTIPLY BY
LINEAR MEASUREMENT	Miles	Kilometers	1.609
	Yards	Meters	0.9144
	Feet	Meters	0.3048
	Feet	Centimeters	30.48
	Inches	Meters	0.0254
	Inches	Centimeters	2.54
	Inches	Millimeters	25.4
AREA	Square Miles	Square Kilometers	2.59
	Square Feet	Square Meters	0.0929
	Square Inches	Square Centimeters	6.452
	Acre	Hectare	0.4047
VOLUME	Cubic Yards	Cubic Meters	0.7646
	Cubic Feet	Cubic Meters	0.02832
	Cubic Inches	Cubic Centimeters	16.39
WEIGHT	Tons (Short)	Metric Tons	0.9078
	Pounds	Kilograms	0.4536
	Ounces (Avdp.)	Grams	28.3495
PRESSURE	Pounds/Sq. In.	Kilopascal	6.895
WORK	Foot-Pounds	Newton-Meter	1.356
LIQUID VOLUME	Quarts	Liters	0.9463
	Gallons	Liters	3.785
LIQUID FLOW	Gallons/Minute	Liters/Minute	3.785
TEMPERATURE	Fahrenheit	Celsius	1. Subtract 32°
			2. Multiply by 5/9

CLICK HERE TO **DOWNLOAD** THE COMPLETE MANUAL

- Thank you very much for reading the preview of the manual.
- You can download the complete manual from: www.heydownloads.com by clicking the link below



- Please note: If there is no response to CLICKING the link, please download this PDF first and then click on it.

CLICK HERE TO **DOWNLOAD** THE COMPLETE MANUAL