

# B250



# Bobcat®

# Service Manual

## B Series

S/N 572911001 & Above

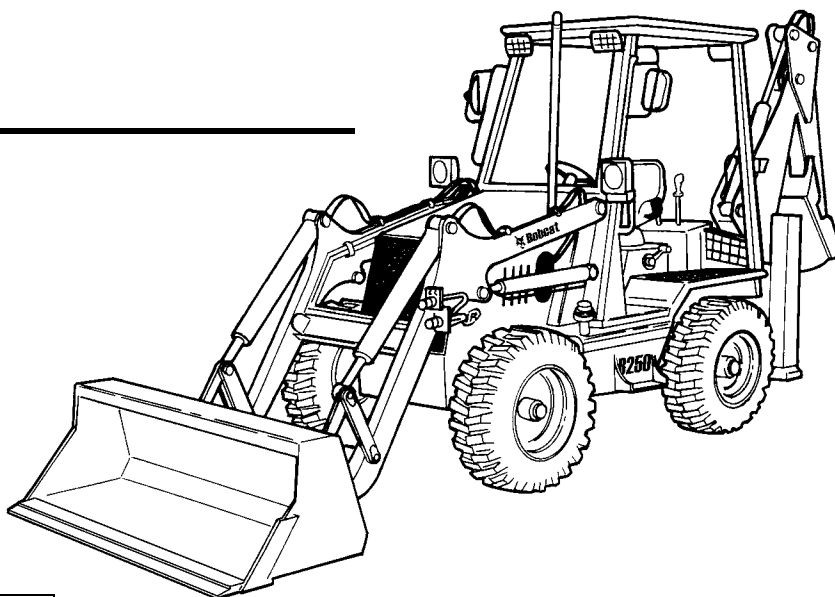

*Doosan purchased Bobcat Company from Ingersoll-Rand Company in 2007. Any reference to Ingersoll-Rand Company or use of trademarks, service marks, logos, or other proprietary identifying marks belonging to Ingersoll-Rand Company in this manual is historical or nominative in nature, and is not meant to suggest a current affiliation between Ingersoll-Rand Company and Bobcat Company or the products of either.*

CLICK HERE TO **DOWNLOAD** THE COMPLETE MANUAL

- Thank you very much for reading the preview of the manual.
- You can download the complete manual from: [www.heydownloads.com](http://www.heydownloads.com) by clicking the link below



- Please note: If there is no response to CLICKING the link, please download this PDF first and then click on it.

CLICK HERE TO **DOWNLOAD** THE COMPLETE MANUAL

## SAFETY INSTRUCTIONS



### Safety Alert Symbol

This symbol with a warning statement means:  
“Warning, be alert! Your safety is involved!”  
Carefully read the message that follows.



## WARNING

Instructions are necessary before operating or servicing machine. Read and understand the Operation & Maintenance Manual, Operator's Handbook and signs (decals) on machine. Follow warnings and instructions in the manuals when making repairs, adjustments or servicing. Check for correct function after adjustments, repairs or service. Untrained operators and failure to follow instructions can cause injury or death.

W-2003-0903



## WARNING

Warnings on the machine and in the manuals are for your safety. Failure to obey warnings can cause injury or death.

W-2044-1285

## IMPORTANT

This notice identifies procedures which must be followed to avoid damage to the machine.

I-2019-0284

The following publications provide information on the safe use and maintenance of the Bobcat machine and attachments:

- The Delivery Report is used to assure that complete instructions have been given to the new owner and that the machine is in safe operating condition.
- The Operation & Maintenance Manual delivered with the machine or attachment contains operating information as well as routine maintenance and service procedures. It is a part of the machine and can be stored in a container provided on the machine. Replacement Operation & Maintenance Manuals can be ordered from your Bobcat dealer.
- Machine signs (decals) instruct on the safe operation and care of your Bobcat machine or attachment. The signs and their locations are shown in the Operation & Maintenance Manual. Replacement signs are available from your Bobcat dealer.
- An Operator's Handbook fastened to the operator cab. It's brief instructions are convenient to the operator. The handbook is available from your dealer in an English edition or one of many other languages. See your Bobcat dealer for more information on translated versions.
- The AEM Safety Manual delivered with the machine gives general safety information.
- The Service Manual and Parts Manual are available from your dealer for use by mechanics to do shop-type service and repair work.
- The Loader Backhoe Operator Training Course is available through your local dealer or at [www.training.bobcat.com](http://www.training.bobcat.com) or [www.bobcat.com](http://www.bobcat.com). This course is intended to provide rules and practices of correct operation of the Loader Backhoe.
- The Loader Backhoe Safety Video is available from your Bobcat dealer or at [www.training.bobcat.com](http://www.training.bobcat.com) or [www.bobcat.com](http://www.bobcat.com).

SI LB-0206 SM

**SAFETY & MAINTENANCE**

AIR CLEANER SERVICE . . . . . 10-80-1  
     Daily Check . . . . . 10-80-1  
     Replacing The Air Filter Element . . . . . 10-80-1

ALTERNATOR BELT . . . . . 10-160-1  
     Adjusting The Alternator Belt . . . . . 10-160-1

APPROVED LIFT ARM SUPPORT DEVICE . . . . . 10-20-1  
     Installing The Approved Lift Arm Support Device . . . . . 10-20-1  
     Removing The Approved Lift Arm Support Device . . . . . 10-20-2

AXLE TOE-IN . . . . . 10-60-1  
     Adjustment . . . . . 10-60-1

BOOM LOCK PIN . . . . . 10-140-1  
     Engaging And Disengaging The Pin . . . . . 10-140-1

BOB-TACH . . . . . 10-150-1  
     Inspection And Maintenance . . . . . 10-150-1

ENGINE COOLING SYSTEM . . . . . 10-90-1  
     Checking Coolant Level . . . . . 10-90-1  
     Cleaning The Cooling System . . . . . 10-90-1  
     Coolant Replacement . . . . . 10-90-2

ENGINE COVER . . . . . 10-30-1

ENGINE LUBRICATION SYSTEM . . . . . 10-110-1  
     Checking Engine Oil . . . . . 10-110-1  
     Oil Chart . . . . . 10-110-1  
     Replacing The Oil And Filter . . . . . 10-110-2

FRONT AXLE . . . . . 10-130-1  
     Checking Oil Level . . . . . 10-130-1  
     Draining Oil . . . . . 10-130-1

FUEL SYSTEM . . . . . 10-100-1  
     Filling The Fuel Tank . . . . . 10-100-1  
     Fuel Filter . . . . . 10-100-1  
     Fuel Specifications . . . . . 10-100-1  
     Removing Air From The Fuel System . . . . . 10-100-3

HYDRAULIC/HYDROSTATIC SYSTEM . . . . . 10-120-1  
     Checking And Adding Fluid . . . . . 10-120-1  
     Cleaning The Cooler . . . . . 10-120-2  
     Replacing Hydraulic Fluid . . . . . 10-120-3  
     Replacing Hydraulic/Hydrostatic Filter . . . . . 10-120-2

**Continued On Next Page**

## TOWING THE LOADER BACKHOE

### Procedure

Place blocks in front and behind rear wheels.

Figure 10-50-1

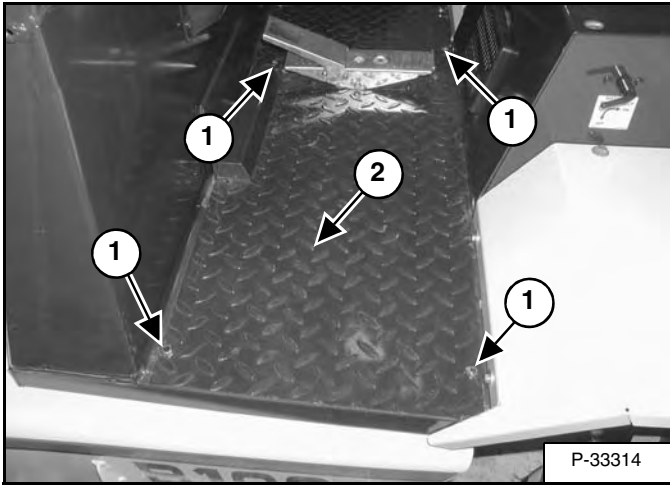

Remove the 4 mounting bolts (Item 1) and floor cover (Item 2) [Figure 10-50-1].

Figure 10-50-2

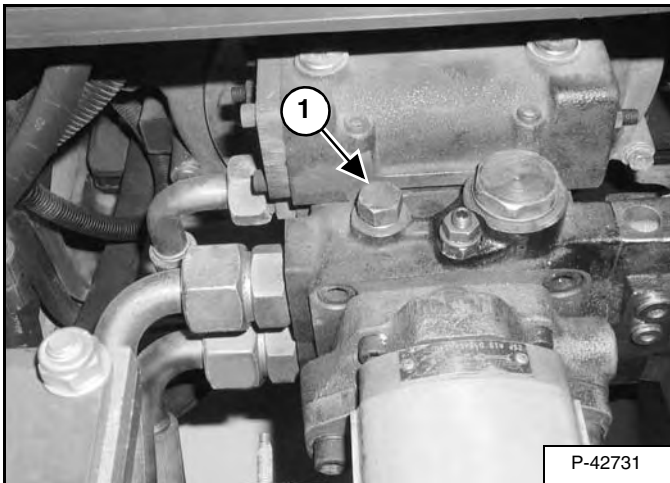

Loosen the tow valve (Item 1) [Figure 10-50-2].

Figure 10-50-3

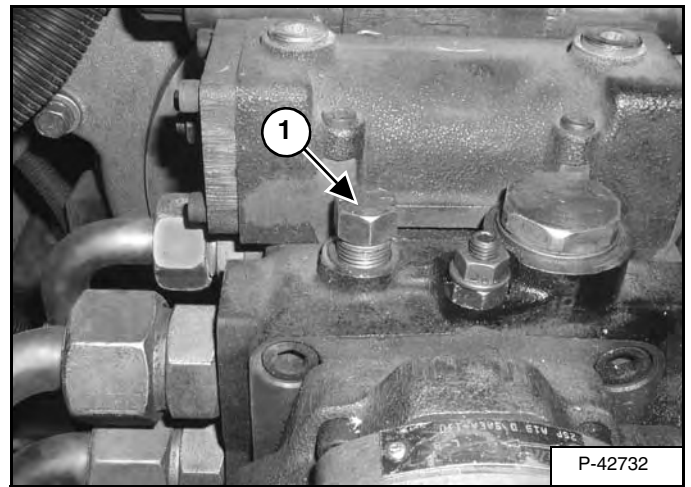

Rotate the tow valve (Item 1) [Figure 10-50-3] counterclockwise approximately 3 turns.

Figure 10-50-4

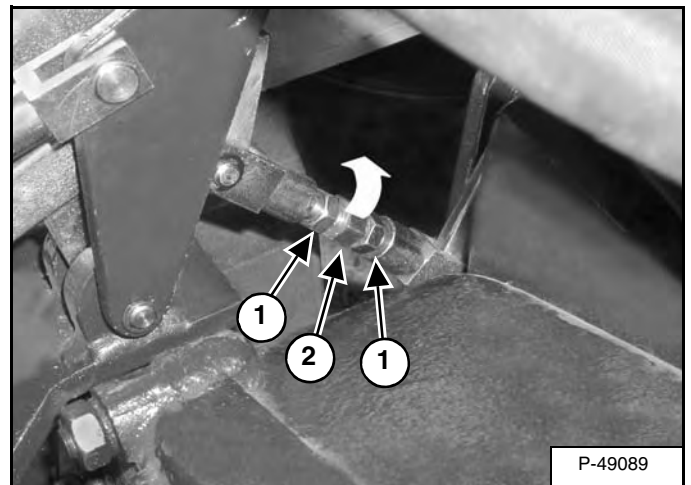

Loosen the 2 jam nuts (Item 1) and turn the parking brake linkage (Item 2) [Figure 10-50-4] approximately 2 turns. (Record the exact amount of turns on the parking brake linkage (Item 2). When putting the machine back in service, you must turn the parking brake linkage back to its original setting.)

To prevent damage to the loader backhoe hydrostatic system, the loader backhoe must be towed only a short distance at a low speed. (Example: Moving the loader backhoe onto a transport vehicle.)

The towing chain (or cable) must be rated at 1-1/2 times the weight of the loader. (See LOADER BACKHOE SPECIFICATIONS on Page SPEC-10-1.)

**NOTE: Be sure to retighten the tow valve and readjust the parking brake linkage before operating the loader backhoe after towing.**

## ENGINE COOLING SYSTEM (CONT'D)

### Coolant Replacement (Cont'd)

Figure 10-90-4

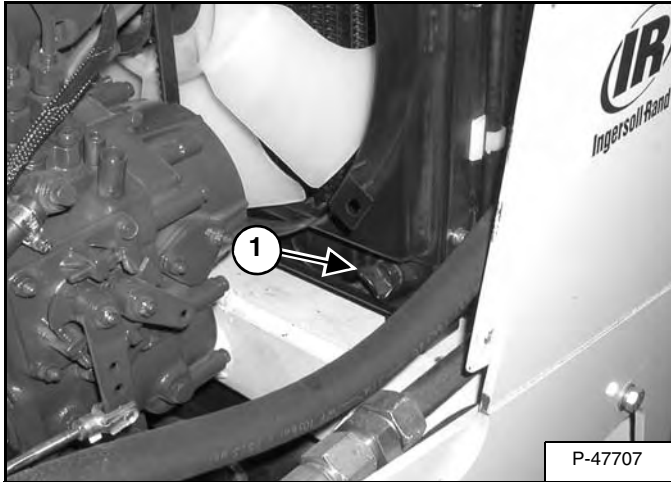

Open the radiator drain valve (Item 1) [Figure 10-90-4] at the right side of the radiator. Drain the coolant into a container.

Figure 10-90-5

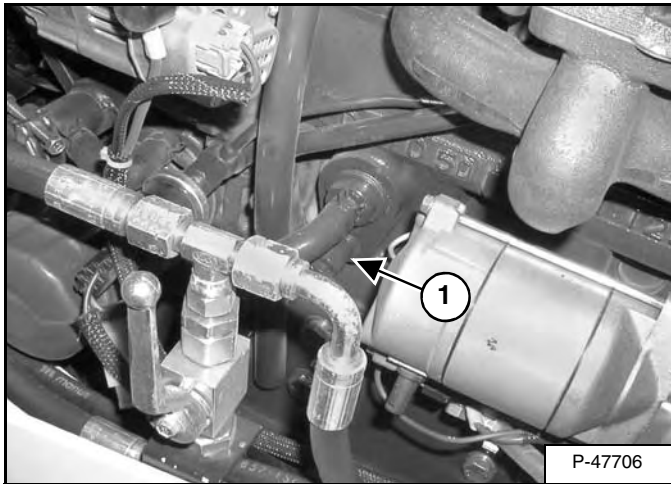

Open the engine block drain valve (Item 1) [Figure 10-90-5] (If Equipped) and drain the coolant into a container. (If not equipped with a drain valve, remove the hose from the fitting to drain the block.)

After all the coolant is removed, close both drain valves.

Recycle or dispose of coolant in an environmentally safe manner.

Mix the coolant in a separate container. (See **LOADER BACKHOE SPECIFICATIONS** on Page SPEC-10-1 for correct capacity.)

**NOTE: The loader backhoe is factory filled with propylene glycol. DO NOT mix propylene glycol with ethylene glycol.**

Premix the coolant; 47% water and 53% propylene glycol.

One gallon and 1 pint (4,3 L) of propylene glycol mixed with 1 gallon (3,8 L) of water is the correct mixture of coolant to provide a -34° F (-37° C) freeze protection.

Use a refractometer to check the condition of propylene glycol in your cooling system.

Fill the radiator with the premixed coolant until it is full. Install the radiator cap.

Fill the coolant recovery tank to the full mark.

Run the engine at idle speed for about 5 to 10 minutes to remove the air from the cooling system.

Stop the engine. Check the coolant level in the coolant recovery tank and add coolant as needed.

## HYDRAULIC/HYDROSTATIC SYSTEM

### Checking And Adding Fluid

Use only recommended fluid in the hydraulic system. (See HYDRAULIC/HYDROSTATIC FLUID SPECIFICATIONS on Page SPEC-50-1)

Put the loader backhoe on a flat level surface.

Remove the boom lock pin. (See BOOM LOCK PIN on Page 10-140-1.)

Remove the swing lock pin. (See SWING LOCK PIN on Page 10-190-1.)

Retract the arm and bucket cylinders, put the bucket on the ground.

Lower the lift arms and tilt the Bob-Tach fully back.

Stop the engine.

#### Figure 10-120-1

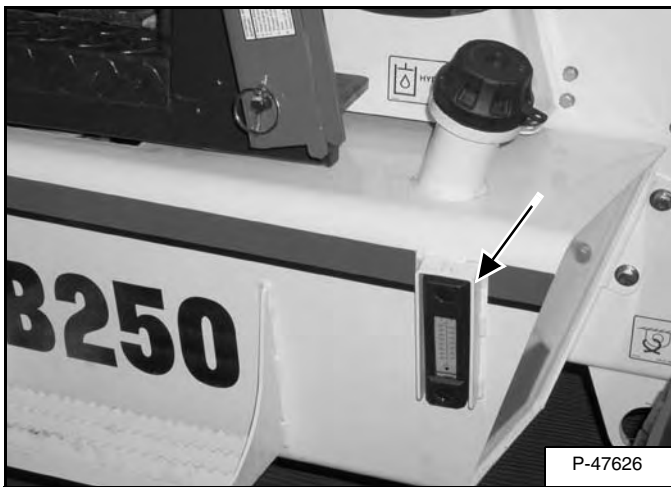

Check that the fluid level in the sight gauge [Figure 10-120-1] is 2/3 to 3/4 full.

#### Figure 10-120-2

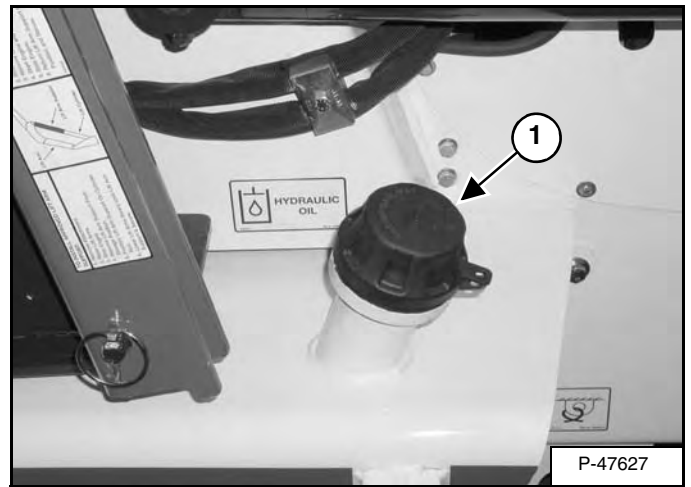

Remove the fill cap (Item 1) [Figure 10-120-2].

#### Figure 10-120-3

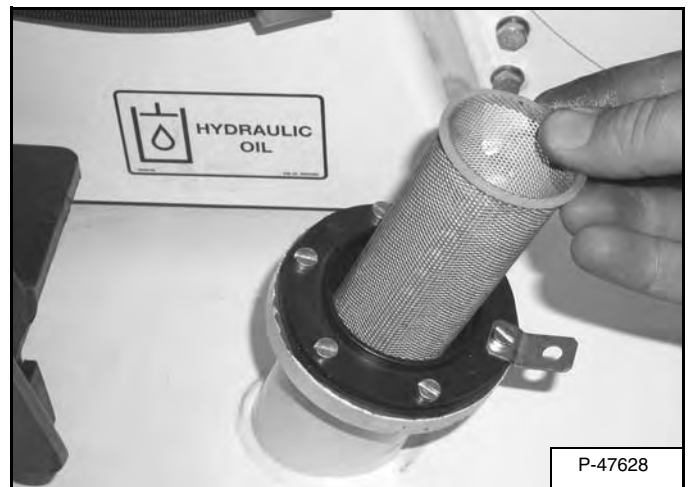

Check the condition of the fill strainer [Figure 10-120-3]. The screen must be installed in the fill neck when adding oil.

Add the fluid as needed to bring the level on the sight gauge to 2/3 to 3/4 full.

Install the fill cap (Item 1) [Figure 10-120-2].

## **WARNING**

Always clean up spilled fuel or oil. Keep heat, flames, sparks or lighted tobacco away from fuel and oil. Failure to use care around combustibles can cause explosion or fire which can result in injury or death.

W-2103-1285

## ALTERNATOR BELT

### Adjusting The Alternator Belt

# WARNING

Never work on a machine with the lift arms up unless the lift arms are secured by an approved lift arm support device. Failure to use an approved lift arm support device can allow the lift arms or attachment to fall and cause injury or death.

W-2059-0598

Raise the lift arms and install the approved lift arm support device. (See Installing The Approved Lift Arm Support Device on Page 10-20-1.)

Stop the engine and engage the parking brake.

Remove the side cover from the left side.

**Figure 10-160-1**

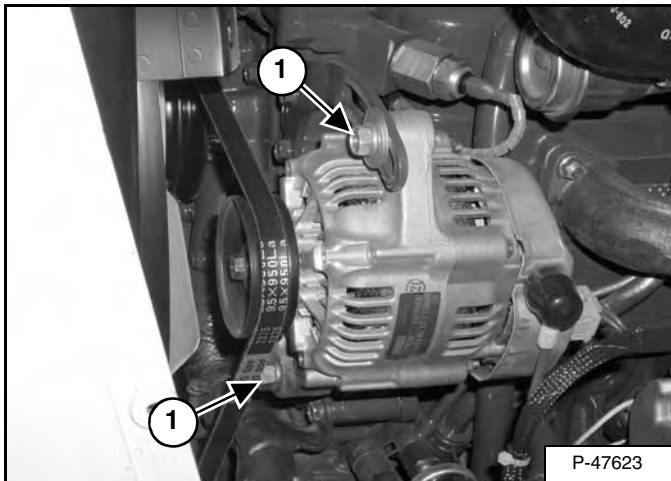

Loosen alternator mounting and adjustment bolts (Item 1) [Figure 10-160-1].

**Figure 10-160-2**

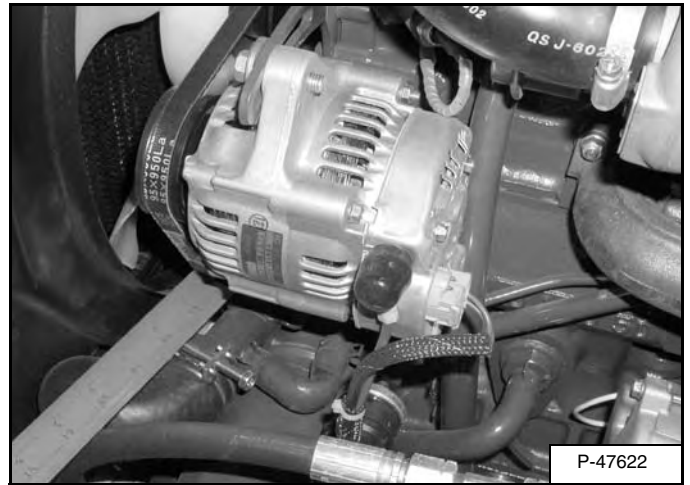

Move the alternator until the belt has 5/16 in. (8,0 mm) movement at the middle of the belt span with 15 lb. (66 N) of force [Figure 10-160-2].

Tighten the adjustment and mounting bolts (Item 1) [Figure 10-160-1].

## SWING LOCK PIN

### Engaging The Swing Lock Pin

**NOTE:** When using both the boom lock pin and the swing lock pin, the boom lock pin should be installed first.

**NOTE:** Attachments wider than a 16 in . backhoe bucket can contact the stabilizer when the backhoe boom is side shifted and fully swung to the side. These attachments must be removed before engaging the swing lock pin.

Figure 10-190-1

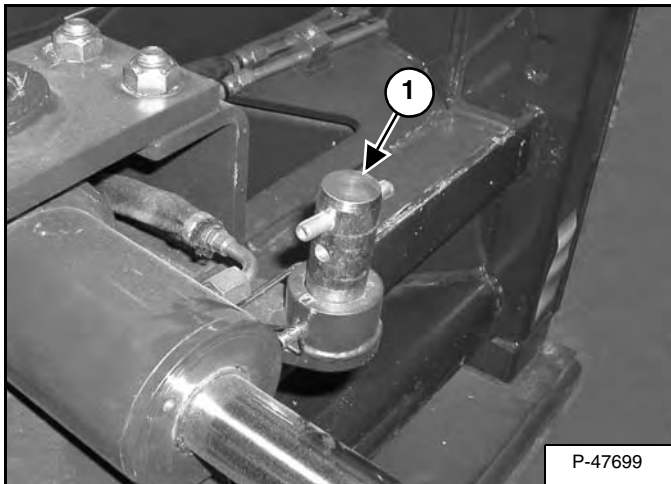

With the swing lock pin (Item 1) [Figure 10-190-1] in the storage position, engage the parking brake, start the engine.

## WARNING

### AVOID CRUSHING HAZARD

- Do not lean over controls.
- Engage and disengage the boom pin and swing lock pin lock with the engine off.
- Do not operate the loader controls from outside the operator's area.

W-2425-0302

Figure 10-190-2

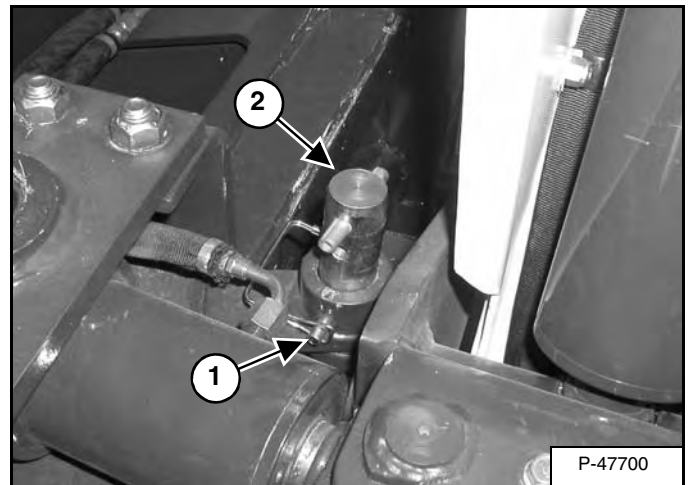

Move the boom to the left or right, stop the engine, engage the parking brake and exit the loader backhoe.

Remove the retainer pin (Item 1) and install the swing lock pin (Item 2) [Figure 10-190-2], by lowering it into the mating boss on the swing frame.

Figure 10-190-3

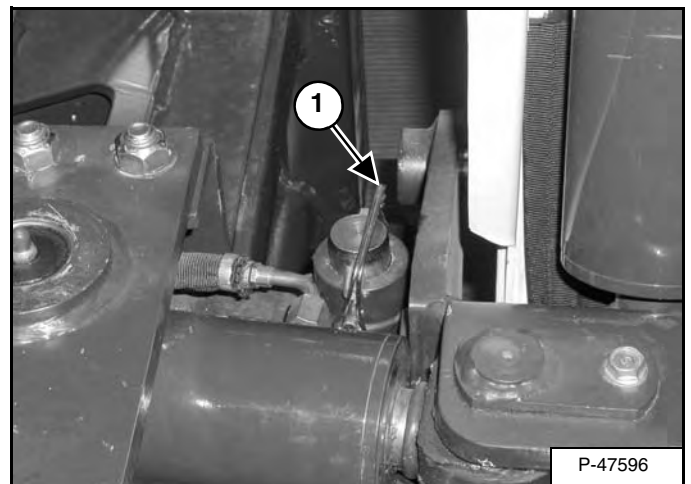

Install the retainer pin (Item 1) [Figure 10-190-3].

## HYDRAULIC SYSTEM INFORMATION (CONT'D)

### Troubleshooting

The following troubleshooting chart is provided for assistance in locating and correcting problems which are most common. Many of the recommended procedures must be done by authorized Bobcat Service Personnel only.



**Check for correct function after adjustments, repairs or service. Failure to make correct repairs or adjustments can cause injury or death.**

W-2004-1285

PROBLEM	CAUSE
The hydraulic system will not operate.	1, 2, 3, 6
The transmission warning light comes ON when hydraulics are operating.	1, 2
Slow hydraulic system action.	1, 2, 4, 8
Hydraulic action is not smooth.	1, 3, 4, 5
Lift arms go up slowly at full engine RPM.	1, 2, 4, 5, 6, 7
The lift arms come down with the lever in neutral position.	7, 8, 9

#### KEY TO CORRECT THE CAUSE

1. The fluid level is not correct.
2. The hydraulic pump has damage.
3. Relief valve is not at the correct pressure.
4. Suction leak on the inlet side of the hydraulic pump.
5. Fluid is cold. Wrong viscosity fluid. (See Specifications on Page SPEC-50-1.)
6. Using the loader for more than its rated capacity.
7. Internal leak in the lift cylinder.
8. External leak from the cylinder(s).
9. Damaged lift spool.

## ARM CYLINDER (CONT'D)

### Assembly (Cont'd)

Figure 20-20-24

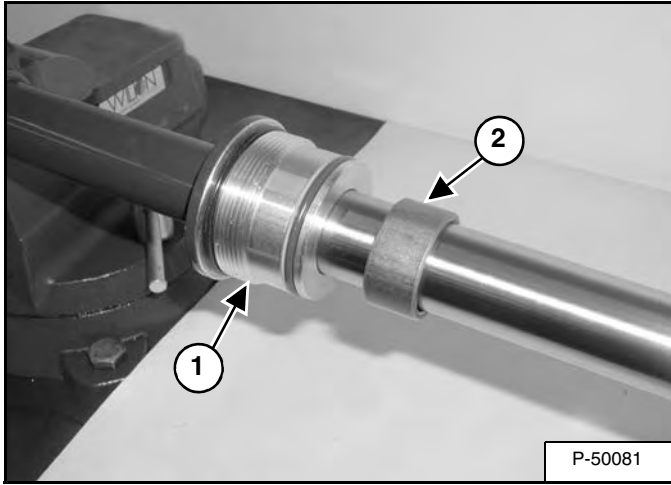

Install the head gland (Item 1) and spacer (Item 2) [Figure 20-20-24] onto the cylinder rod.

Figure 20-20-25

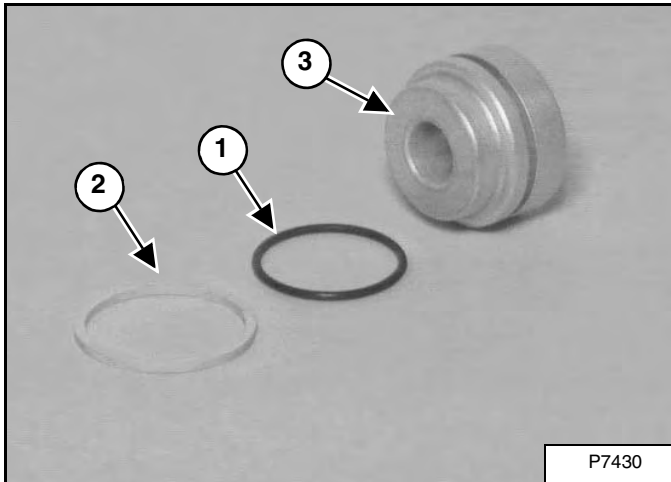

Install the O-ring (Item 1) and seal (Item 2) onto the piston (Item 3) [Figure 20-20-25].

Figure 20-20-26

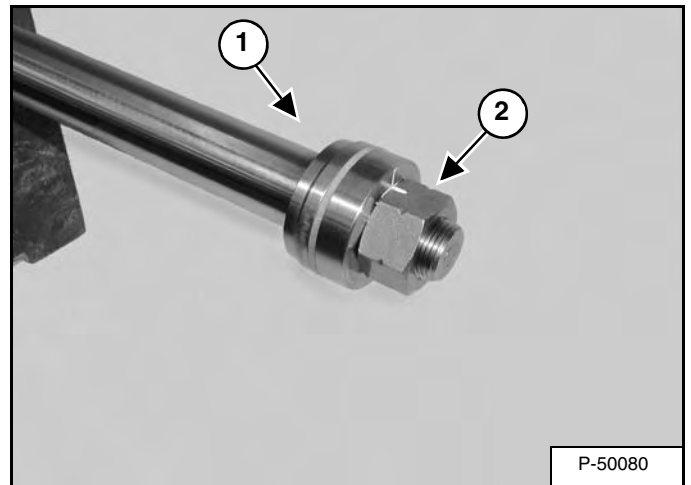

Clean and dry the cylinder rod threads. Install the piston (Item 1). Apply Loctite™ 242 or equivalent to the cylinder rod threads and install the nut (Item 2) [Figure 20-20-26].

**Installation:** Tighten the nut to 10 5 ft.-lb. (142 N•m) torque.

Figure 20-20-27

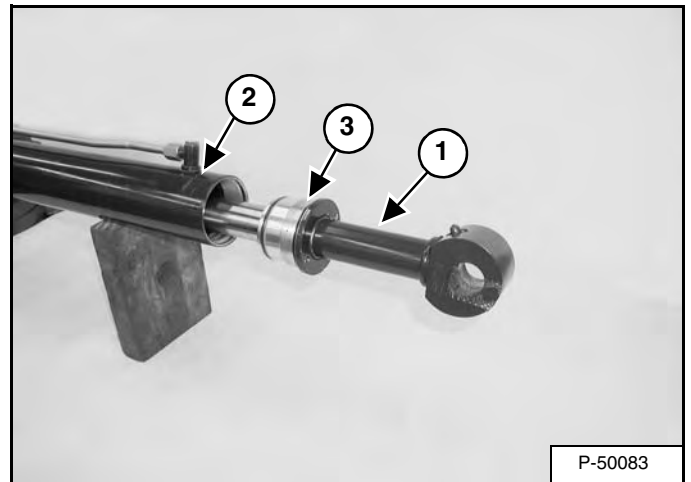

Install the rod assembly (Item 1), into the housing (Item 2) and tighten the head gland (Item 3) [Figure 20-20-27].

## BOOM CYLINDER (CONT'D)

### Disassembly (Cont'd)

Figure 20-21-27

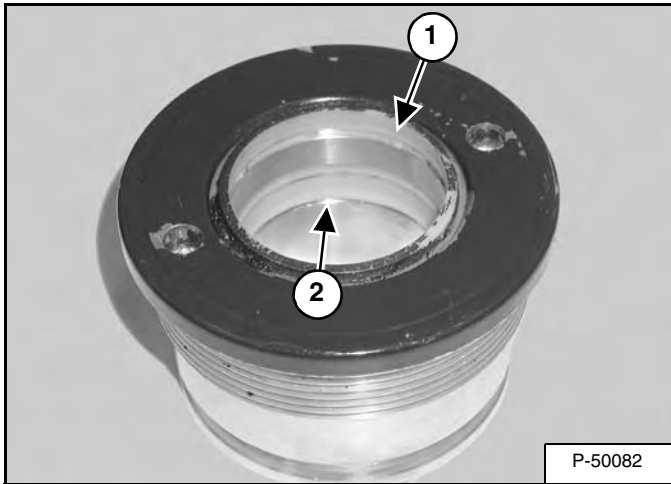

Remove the wiper (Item 1) and rod seal (Item 2) [Figure 20-21-27] from the head gland.

### Assembly

Wash the cylinder parts in solvent and dry with compressed air.

Inspect the cylinder parts for wear or damage. Replace any worn or damaged parts.

Lubricate all O-rings and seals with clean hydraulic oil during installation.

Figure 20-21-28

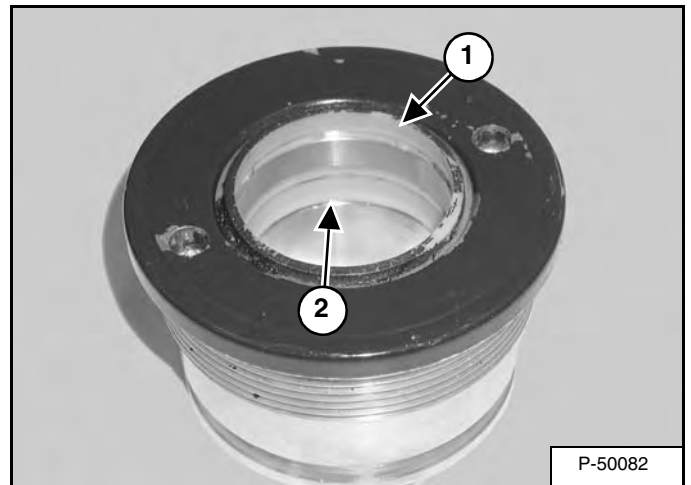

Install the wiper (Item 1) and rod seal (Item 2) [Figure 20-21-28] in the head gland.

Figure 20-21-29

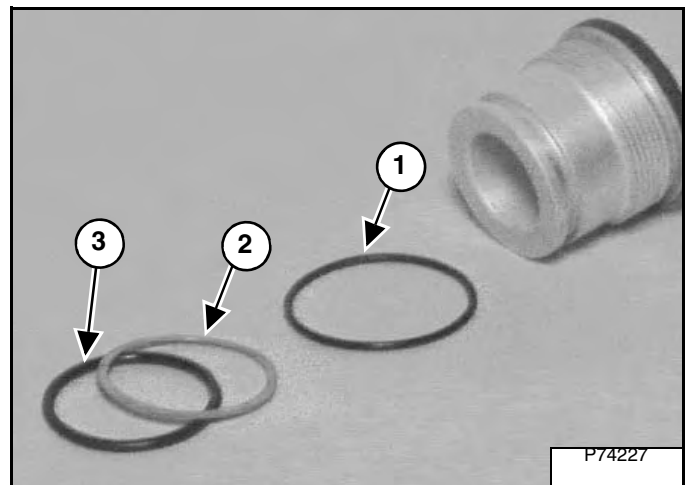

Install the O-ring (Item 1), backup washer (Item 2) and O-ring (Item 3) [Figure 20-21-29] on the head gland.

## SWING CYLINDER (CONT'D)

### Assembly (Cont'd)

Figure 20-22-25

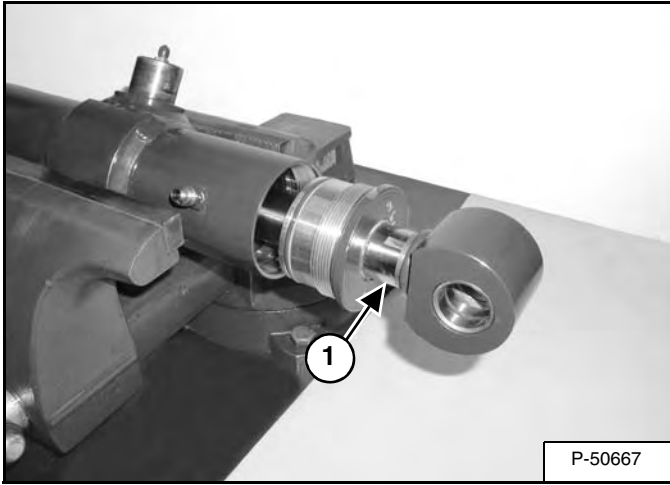

Install the rod assembly (Item 1) [Figure 20-22-25] into the housing.

Figure 20-22-26

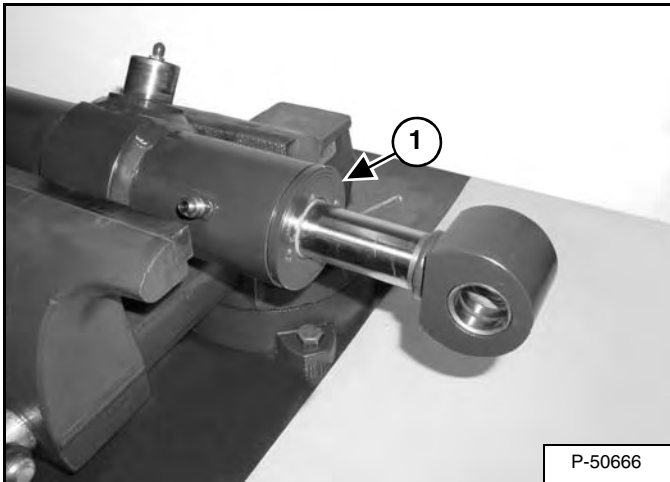

Use a gland nut wrench (MEL1075) to tighten the head gland (Item 1) [Figure 20-22-26].

### Bushing Removal And Installation

Inspect all bushings and replace as necessary.

Figure 20-22-27

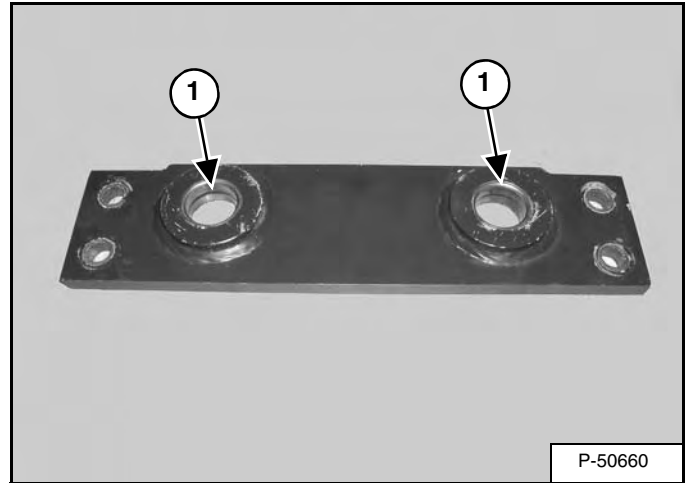

Remove the bushings (Item 1) [Figure 20-22-27].

**NOTE:** For correct assembly note the direction of the bushing as it is removed.

**Installation:** Install the bushings until they are flush with the support.

Figure 20-22-28

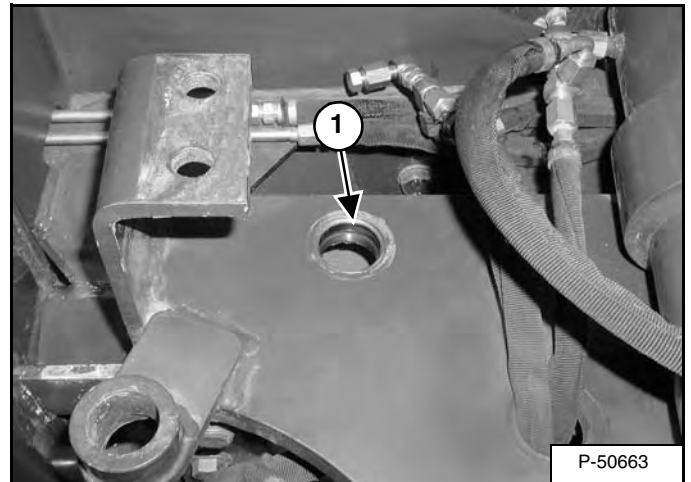

Remove the bushing (Item 1) [Figure 20-22-28].

**NOTE:** For correct assembly note the direction of the bushing as it is removed.

**Installation:** Install the bushing until they are flush with the support.

## BUCKET CYLINDER (CONT'D)

### Disassembly (Cont'd)

Figure 20-23-26

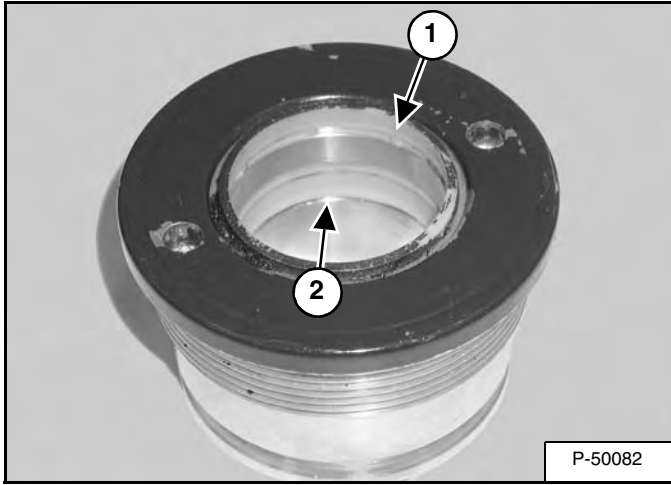

Remove the wiper (Item 1) and rod seal (Item 2) [Figure 20-23-26] from the head gland.

### Assembly

Wash the cylinder parts in solvent and dry with compressed air.

Inspect the cylinder parts for wear or damage. Replace any worn or damaged parts.

Lubricate all O-rings and seals with clean hydraulic oil during installation.

Figure 20-23-27

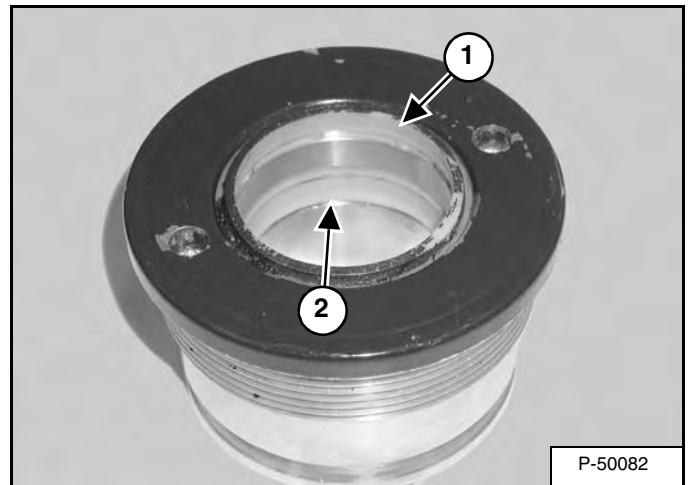

Install the wiper (Item 1) and rod seal (Item 2) [Figure 20-23-27] in the head gland.

Figure 20-23-28

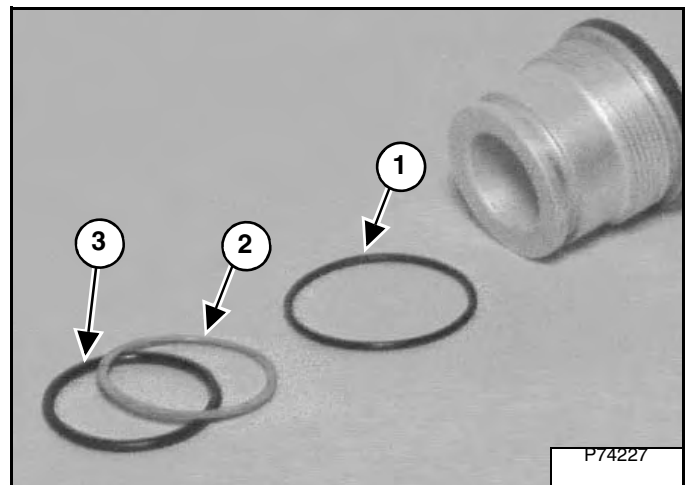

Install the O-ring (Item 1), backup washer (Item 2) and O-ring (Item 3) [Figure 20-23-28] on the head gland.

## STABILIZER CYLINDER (CONT'D)

### Disassembly (Cont'd)

Figure 20-24-24

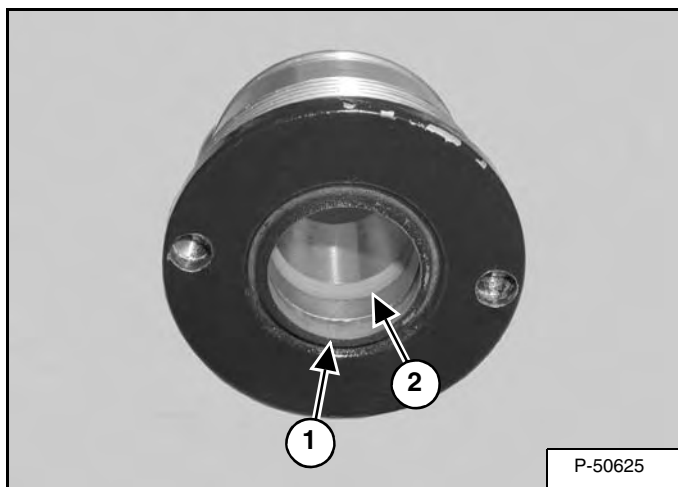

Remove the wiper seal (Item 1) and rod seal (Item 2)  
**[Figure 20-24-24].**

## TILT CYLINDER

### Checking

Remove attachment from the Bob-Tach.

Lower the lift arms to the ground, fully retract the tilt cylinders.

Stop the engine, engage the parking brake.

Operate the control lever to relieve hydraulic pressure.



Hydraulic fluid escaping under pressure can have sufficient force to enter a person's body by penetrating the skin. This can cause serious injury and possible death if proper medical treatment by a physician familiar with this injury is not received immediately.

W-2145-0290

Figure 20-30-1

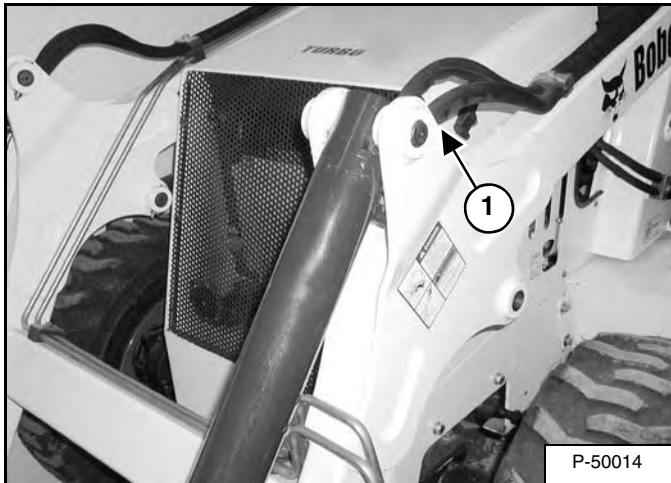

Check only one cylinder at a time. Disconnect the hose (Item 1) [Figure 20-30-1] from the base end of the tilt cylinder.

Figure 20-30-2

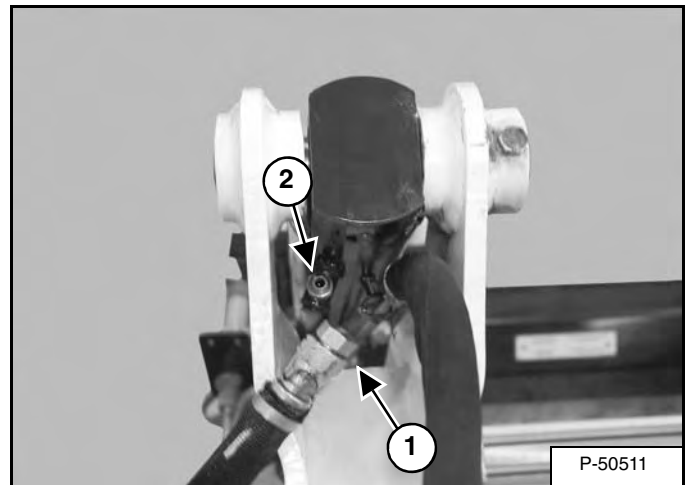

Install a plug (Item 1) [Figure 20-30-2] in the hose and tighten.

With the parking brake engaged, start the engine and retract the cylinder.

Stop the engine and engage the parking brake.

If there is any leakage from the base end fitting (Item 2) [Figure 20-30-2], remove the cylinder for repair or replacement.

## LIFT CYLINDER (CONT'D)

### Removal And Installation (Cont'd)

Figure 20-31-6

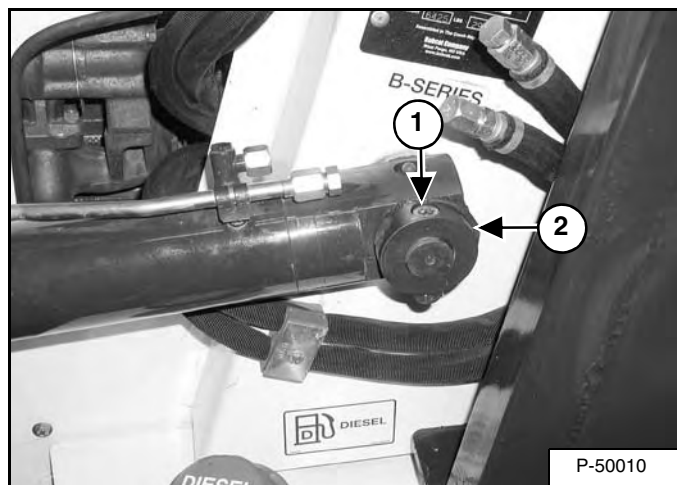

Remove the retainer bolt (Item 1) and retainer (Item 2) [Figure 20-31-6].

**Installation:** Tighten the retainer bolt and nut to 18 to 20 ft.-lb. (24 to 27 N•m) torque.

Remove the cylinder.

# STEERING CYLINDER (FRONT) (CONT'D)

## Parts Identification

- 1 CYLINDER
- 2 JOINT
- 3 NUT
- 4 TIE ROD
- 5 O-RING
- 6 ROD
- 7 HEAD
- 8 BOLT
- 9 SEAL
- 10 WIPER

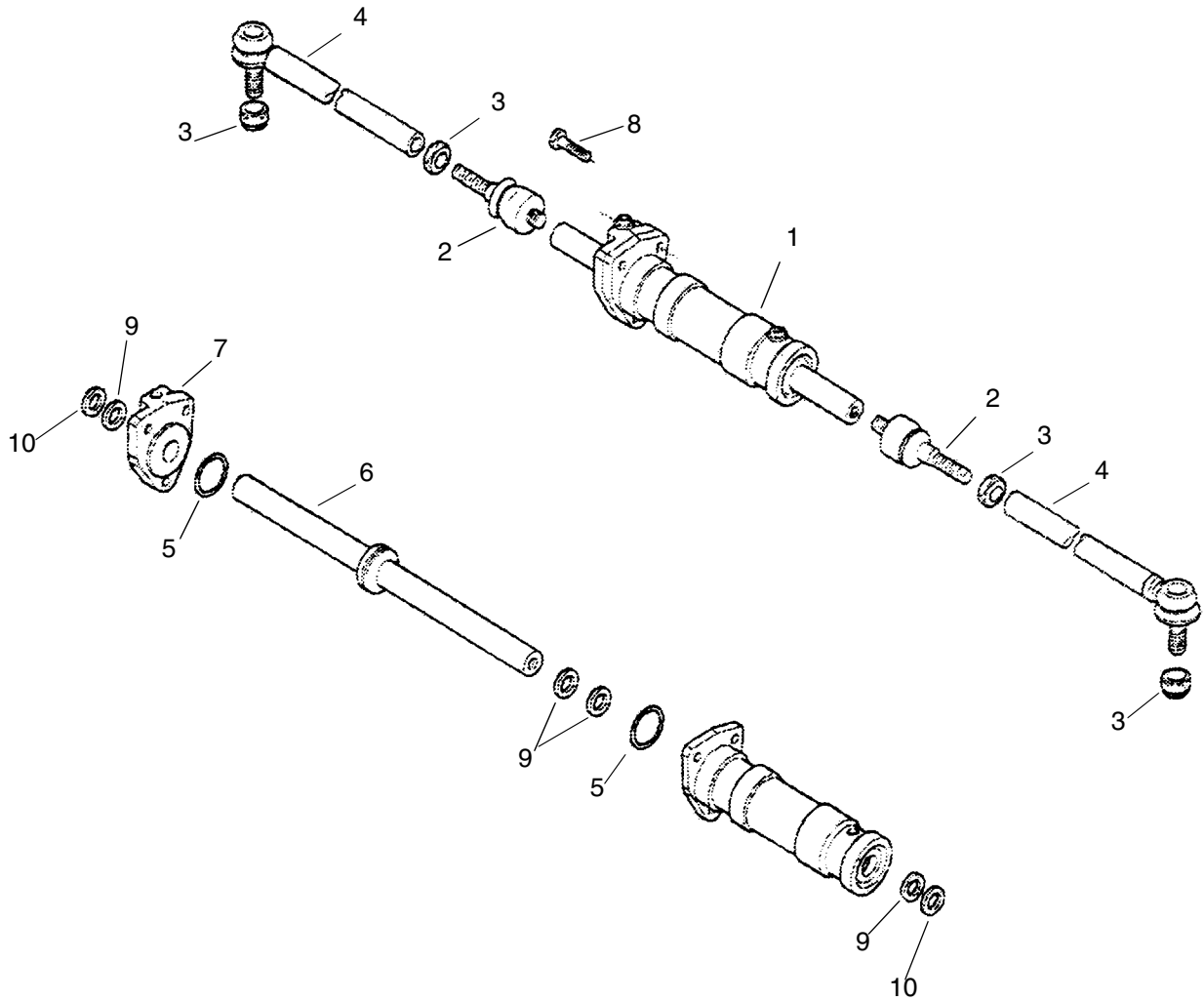

B-19711A

## STEERING CYLINDER (REAR) (CONT'D)

### Disassembly And Assembly

Figure 20-33-12

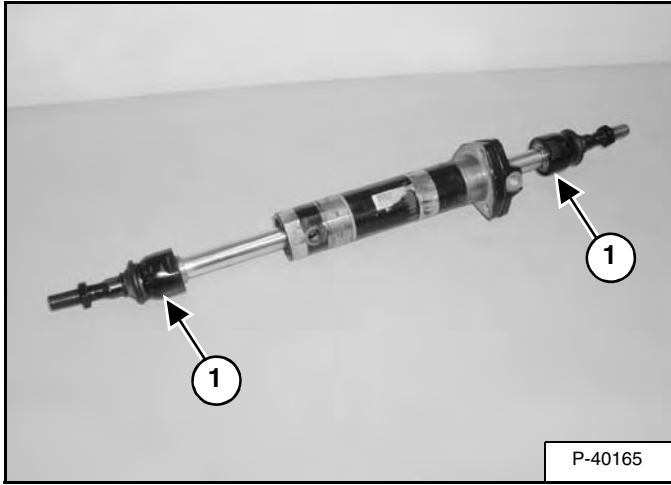

Mark the ball joints (Item 1) [Figure 20-33-12] for correct assembly to steering cylinder.

Figure 20-33-13

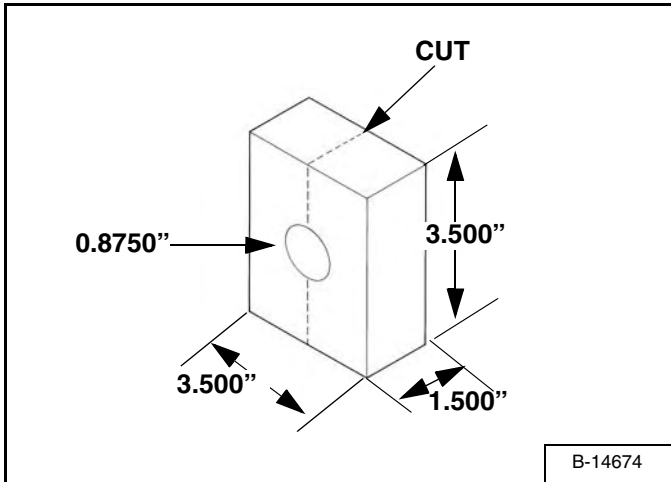

To remove the ball joint from the rod, a holding fixture will have to be made from a 1.500 in. thick x 3.500 in. wide x 3.500 in. long (38 mm thick x 89 mm wide x 89 mm long) piece of hardwood. Drill a 0.8750 in. (22 mm) hole in the center of the hardwood block. Cut the block lengthwise [Figure 20-33-13].

Figure 20-33-14

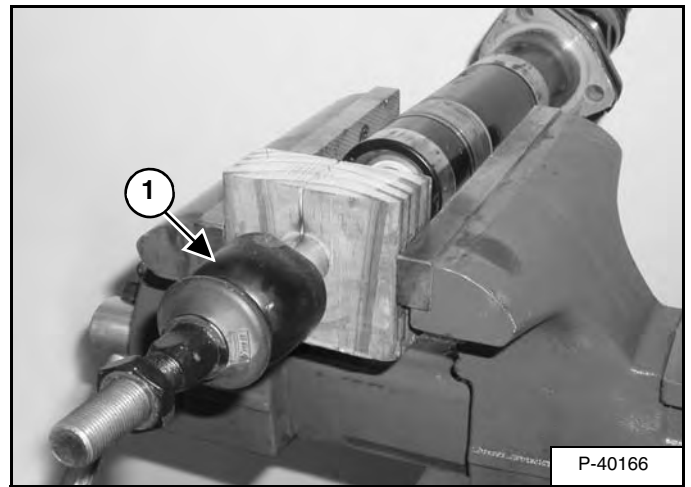
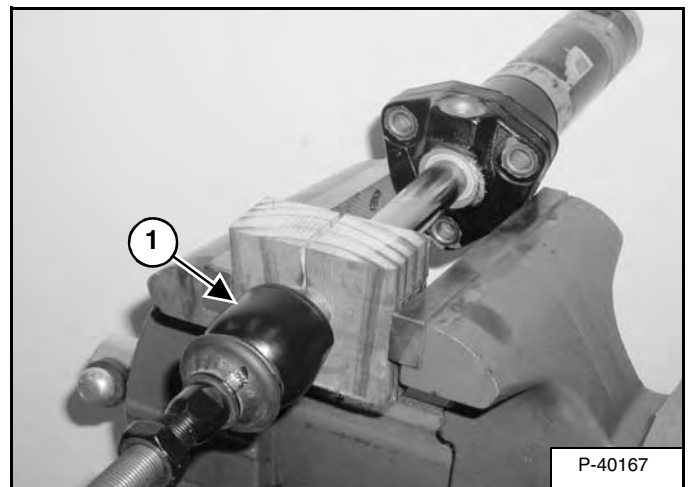

Figure 20-33-15



Place both halves of the hardwood block around the rod. Clamp the blocks in a vise [Figure 20-33-14] and [Figure 20-33-15].

**NOTE: Do not use anything other than hardwood blocks to grip the rod, or the rod will be damaged.**

Apply moderate heat to ball joint (Item 1) [Figure 20-33-14] and (Item 1) [Figure 20-33-15] to break thread sealant. Remove the ball joints (Item 1) [Figure 20-33-14] and (Item 1) [Figure 20-33-15].

**NOTE: Ball joint is threaded into rod end.**

## PORT RELIEF VALVE (BACKHOE CONTROL VALVE) (CONT'D)

### Testing And Adjusting (Bucket Control) (Cont'd)

Figure 20-41-8

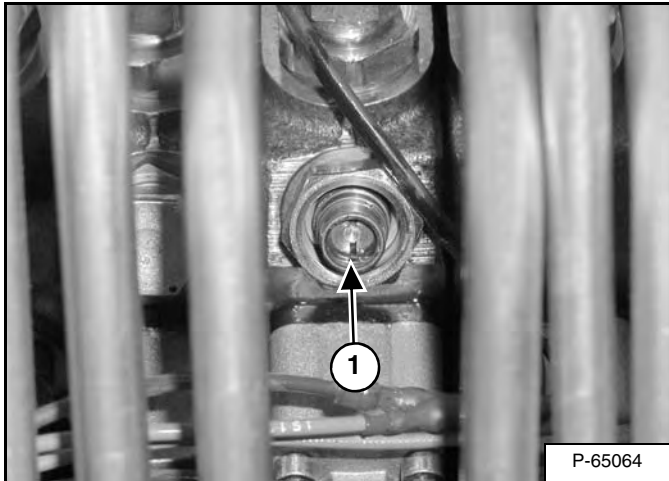

Turn the adjusting screw (Item 1) [Figure 20-41-8] clockwise to increase the pressure and counterclockwise to reduce the pressure.

**NOTE:** 1/4 turn is approximately 300 PSI (21 bar) when the correct pressure setting is obtained, tighten the locknut while holding the adjustment screw from turning.

Adjust the port relief valve until the correct setting is obtained.

## **WARNING**

**Wear safety glasses to prevent eye injury when any of the following conditions exist:**

- When fluids are under pressure.
- Flying debris or loose material is present.
- Engine is running.
- Tools are being used.

W-2019-1285

## LOADER CONTROL VALVE (CONT'D)

### Parts Identification

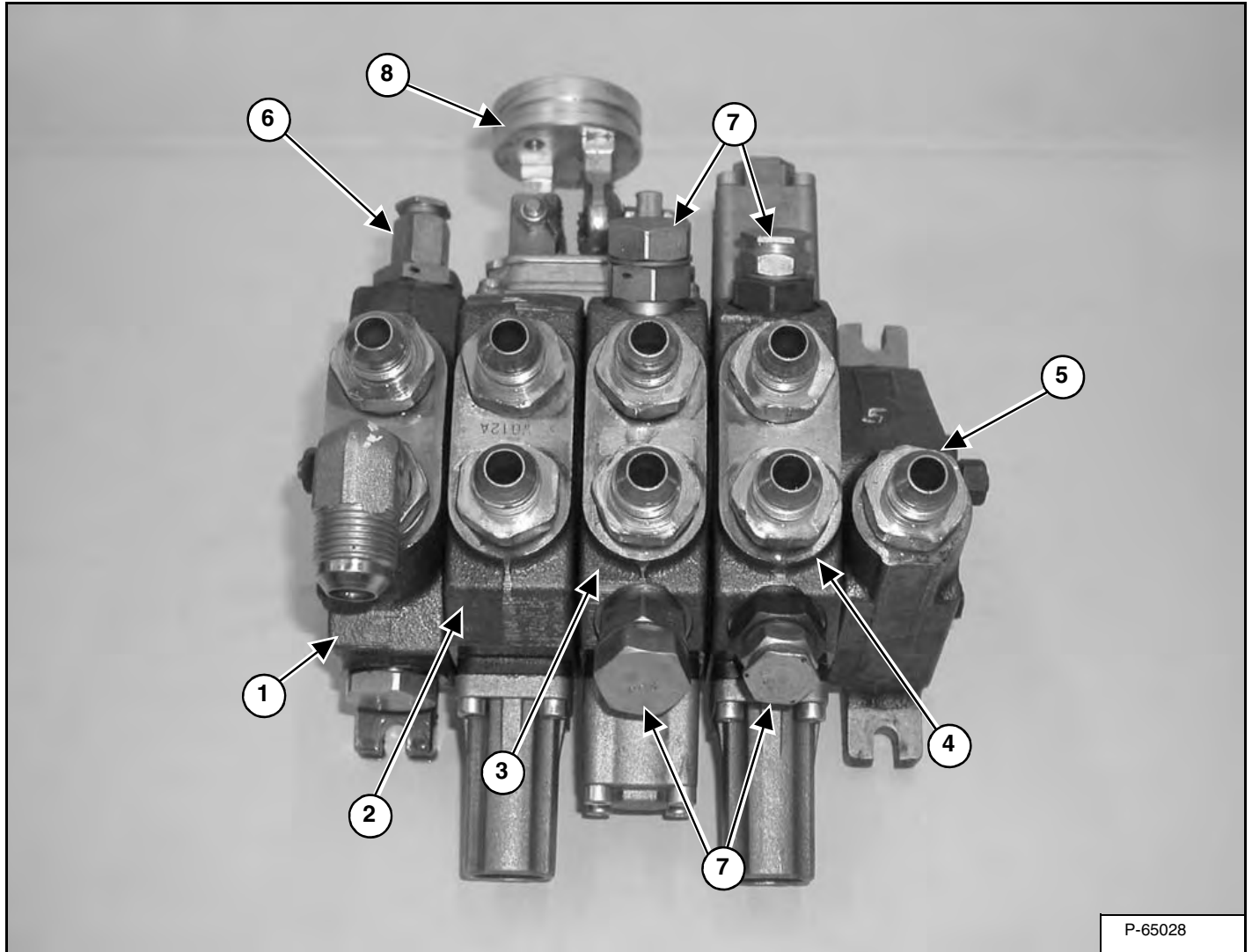

ITEM	B250 LOADER BACKHOE
1	Inlet/Outlet Valve Section
2	Lift Arm Valve Section
3	Tilt Valve Section
4	Auxiliary Valve Section
5	Outlet Section
6	Main Relief
7	Port Relief
8	Control Plate

## LOADER CONTROL VALVE (CONT'D)

### Tilt Valve Section (Cont'd)

Figure 20-50-42

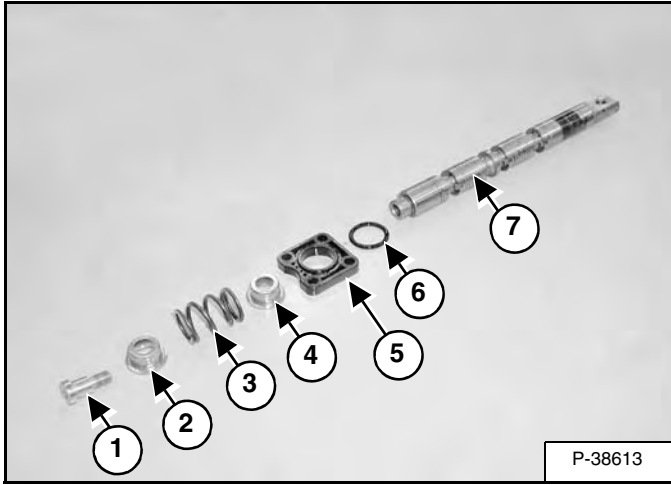

Remove the bolt (Item 1), spring retainer (Item 2), spring (Item 3), spring retainer (Item 4), seal (Item 5) and O-ring (Item 6) from the spool (Item 7) [Figure 20-50-42].

Figure 20-50-43

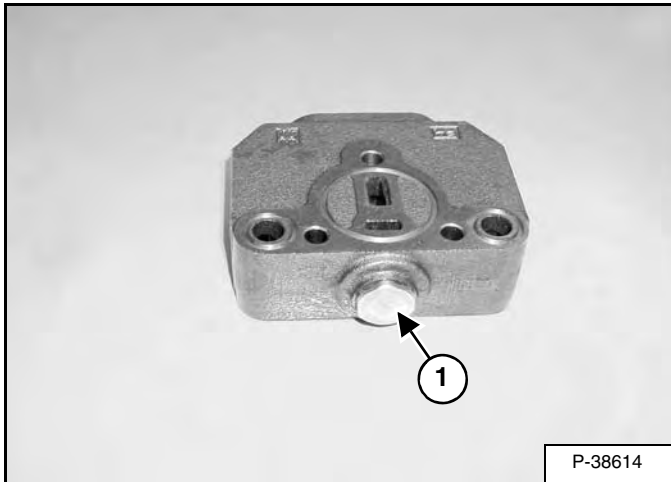

Loosen the plug (Item 1) [Figure 20-50-43].

Figure 20-50-44

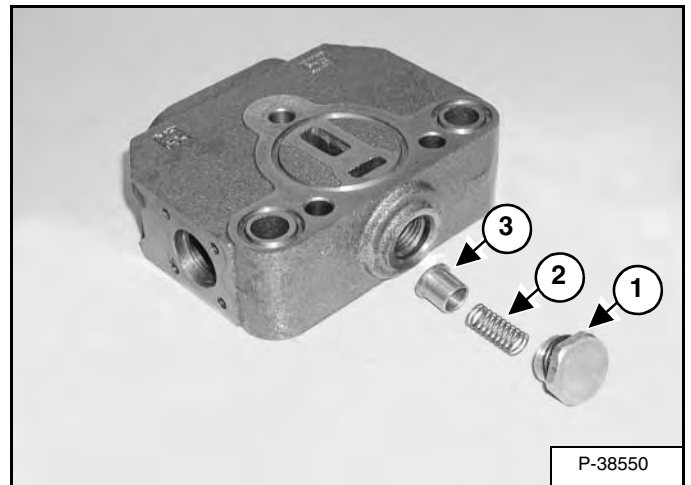

Remove the plug (Item 1), spring (Item 2) and poppet (Item 3) [Figure 20-50-44].

Figure 20-50-45

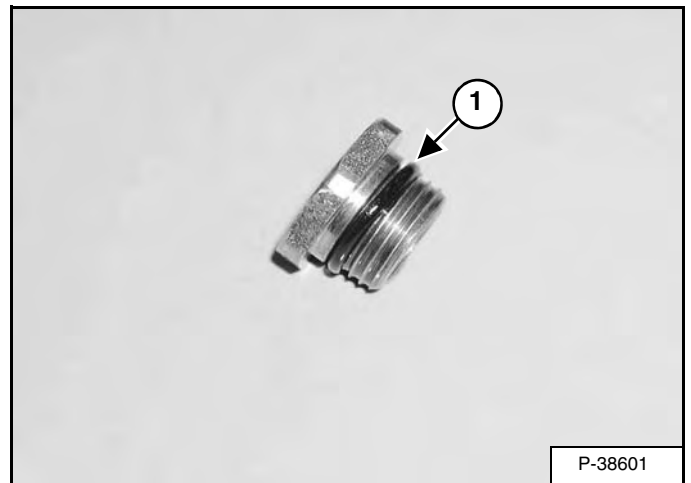

Remove the O-ring (Item 1) [Figure 20-50-45] from the plug.

## BACKHOE CONTROL VALVE (CONT'D)

### Disassembly And Assembly (Cont'd)

Figure 20-60-11

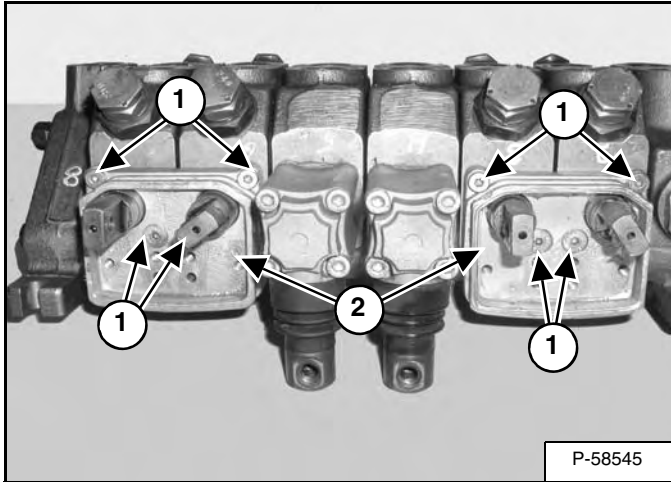

Remove the 8 bolts (Item 1) and 2 plates (Item 2) [Figure 20-60-11].

**Assembly:** Apply Loctite™ 242 or equivalent to threads of bolts.

Figure 20-60-12

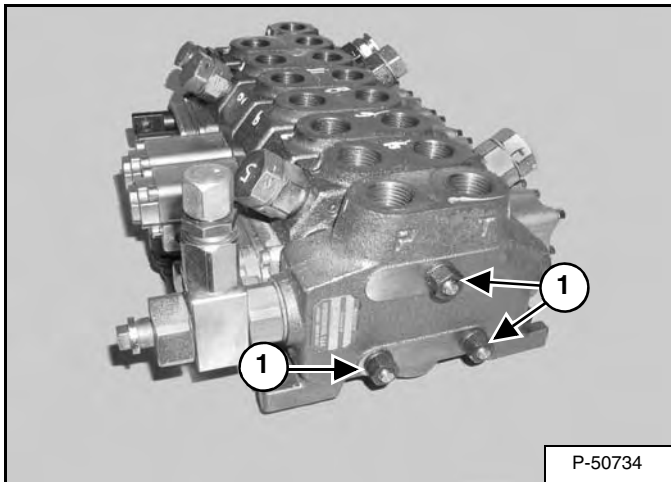

Remove the thru-bolt nuts and washers (Item 1) [Figure 20-60-12].

**Installation:** Tighten nuts to 32 to 35 ft.-lb. (43 to 47 N•m) torque.

## Inlet/Outlet Valve Section

Figure 20-60-13

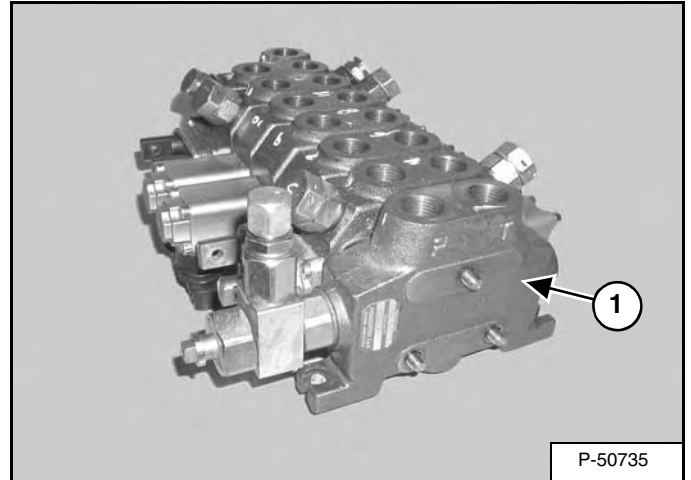

Remove the inlet/outlet valve section (Item 1) [Figure 20-60-13]

Figure 20-60-14

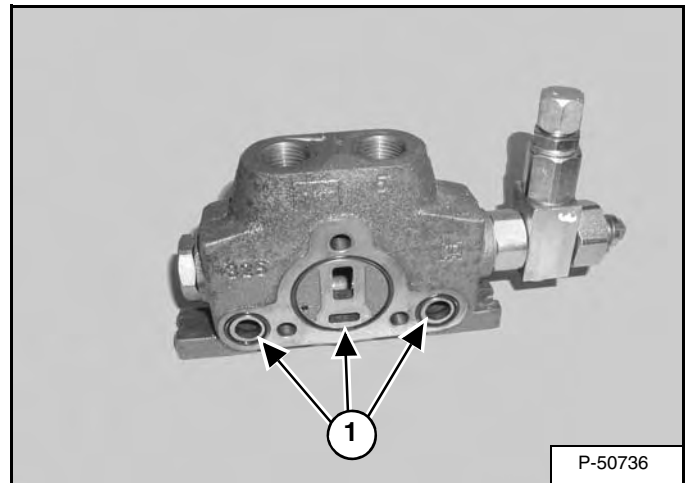

Remove the 3 O-rings (Item 1) [Figure 20-60-14]

## BACKHOE CONTROL VALVE (CONT'D)

### Right Stabilizer Valve Section (Cont'd)

Figure 20-60-48

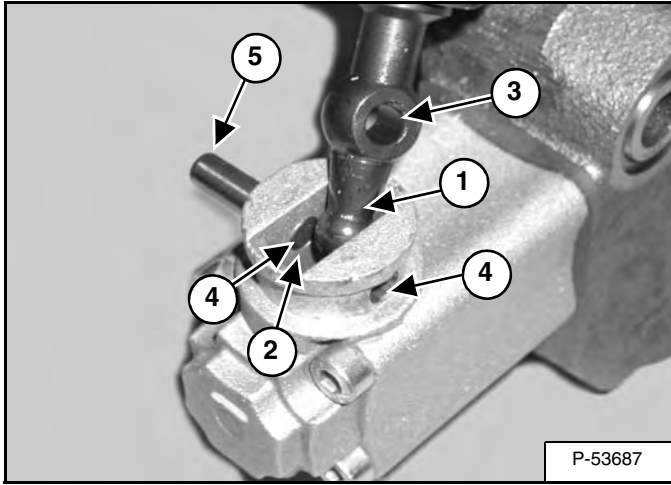

**Installation:** Install the end of the actuator (Item 1) into the hole (Item 2) in the spool. Align the hole (Item 3) in the actuator with the pin holes (Item 4) and install the pin (Item 5) [Figure 20-60-48].

Figure 20-60-49

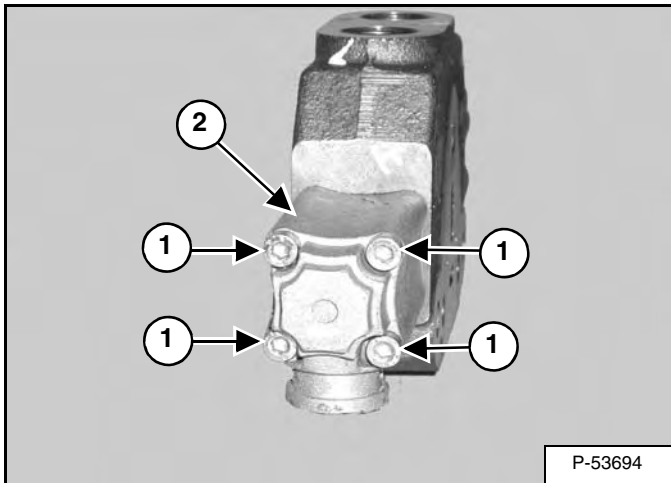

Remove the 4 bolts (Item 1) and the cover (Item 2) [Figure 20-60-49].

**Assembly:** Tighten the bolts to 2 to 2.5 ft.-lb. (2,5 to 3,5 N•m) torque.

Figure 20-60-50

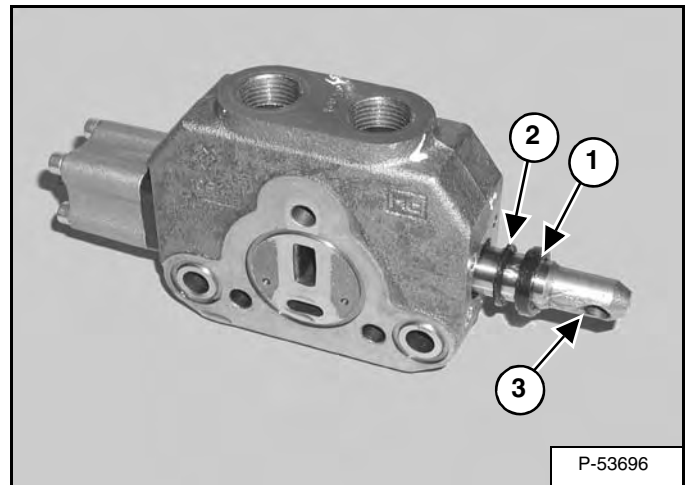

Remove the seal (Item 1) and O-ring (Item 2) from the actuating end of spool (Item 3) [Figure 20-60-50].

Figure 20-60-51

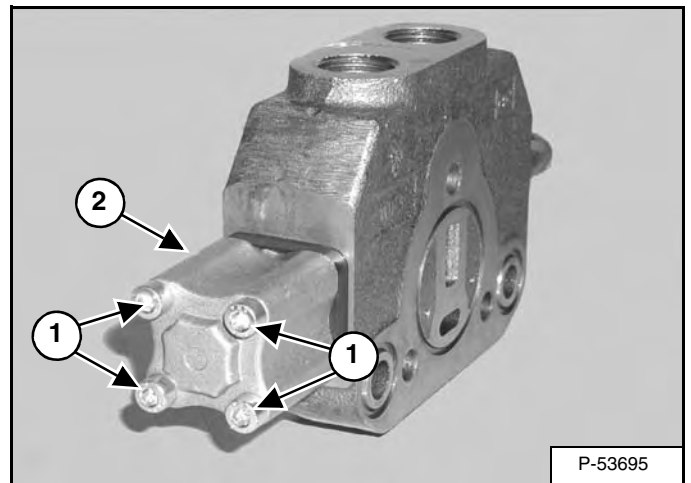

Remove the 4 bolts (Item 1) and cover (Item 2) [Figure 20-60-51].

**Assembly:** Tighten the bolts to 2 to 2.5 ft.-lb. (2,5 to 3,5 N•m) torque.

## BACKHOE CONTROL VALVE (CONT'D)

### Boom Swing Valve Section (Cont'd)

Figure 20-60-88

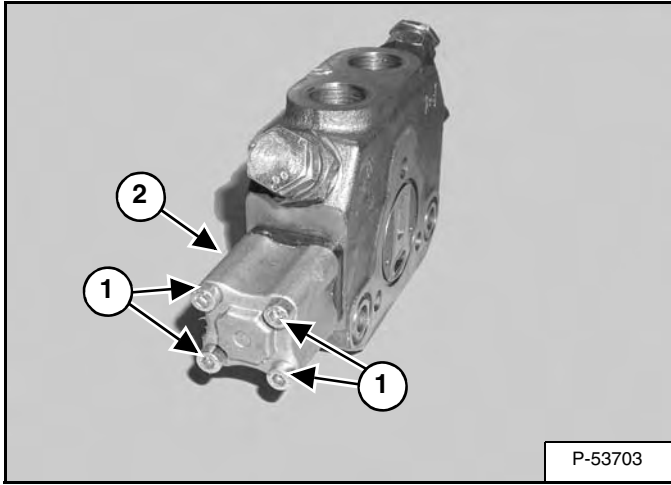

Remove the 4 bolts (Item 1) and cover (Item 2) [Figure 20-60-88].

**Assembly:** Tighten the bolts to 2 to 2.5 ft.-lb. (2,5 to 3,5 N•m) torque.

Figure 20-60-89

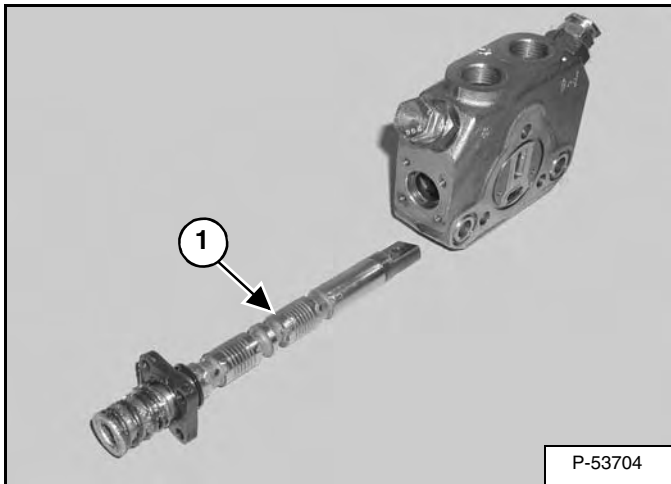

Remove the spool assembly (Item 1) [Figure 20-60-89]. Check the spool for damage or wear. Replace as needed.

Figure 20-60-90

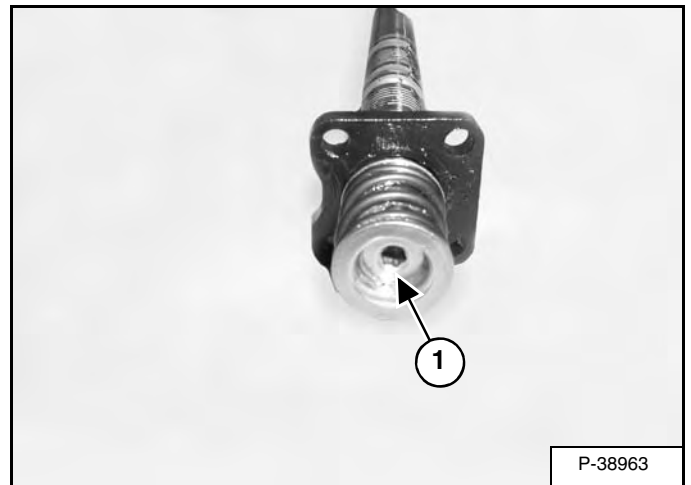

Loosen the bolt (Item 1) [Figure 20-60-90].

**Assembly:** Tighten the bolt to 6 ft.-lb. (8,0 N•m) torque.

Figure 20-60-91

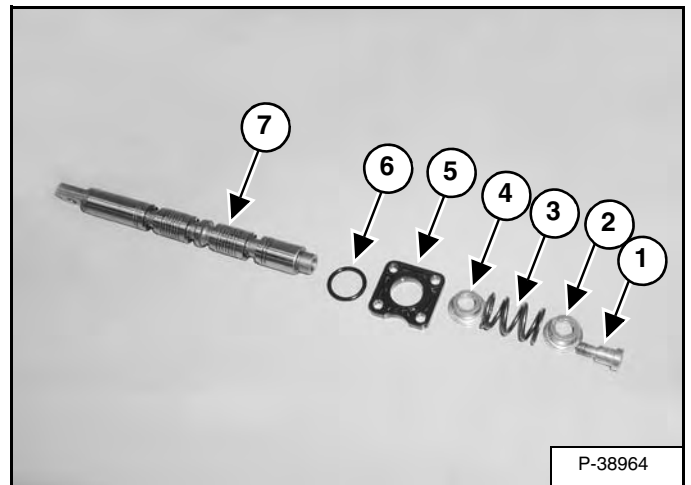

Remove the bolt (Item 1), spring retainer (Item 2), spring (Item 3), spring retainer (Item 4), seal (Item 5) and O-ring (Item 6) from the spool (Item 7) [Figure 20-60-91].

## HYDRAULIC FILTER HOUSING (CONT'D)

### Disassembly (Cont'd)

Figure 20-71-8

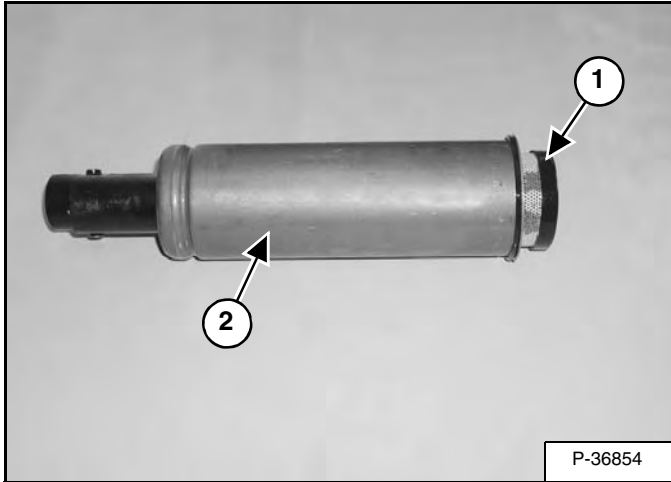

Remove the filter (Item 1) from the bypass housing (Item 2) [Figure 20-71-8].

Figure 20-71-9

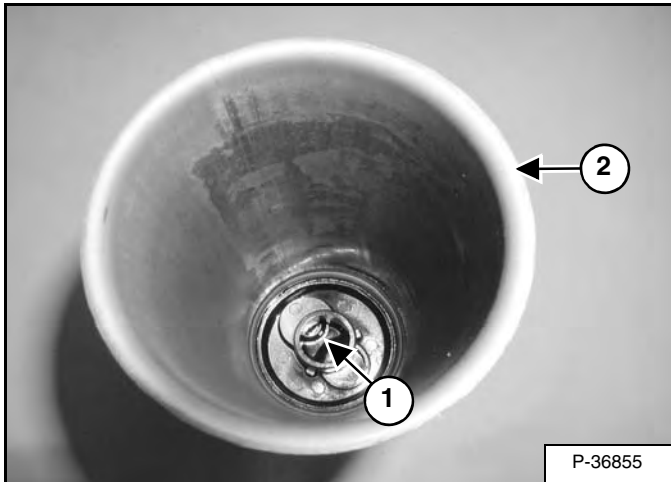

Inspect the one way check valve (Item 1) in the bypass housing (Item 2) [Figure 20-71-9] for closing and free movement.

Figure 20-71-10

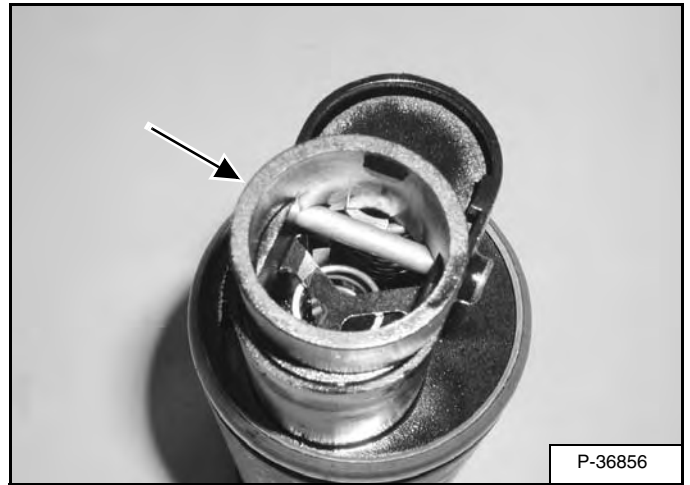

Inspect the bypass valves and springs [Figure 20-71-10].

### Assembly

Wash filter housing parts in solvent and dry with compressed air.

Inspect filter housing parts for damage. Replace any damaged parts or replace assembly as necessary.

Figure 20-71-11

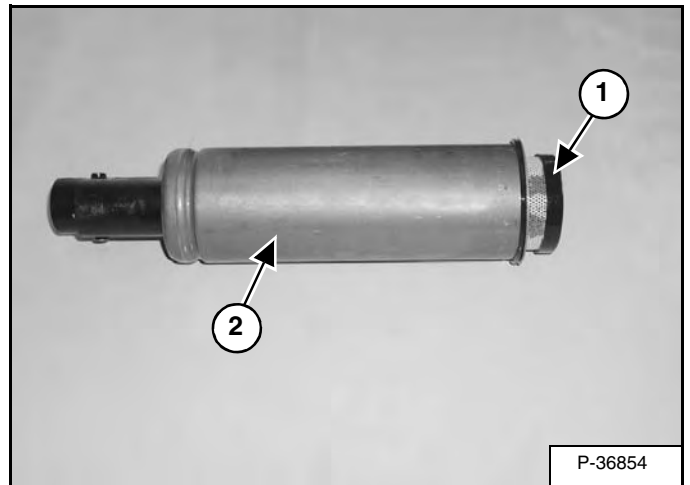

Install the filter (Item 1) into bypass housing (Item 2) [Figure 20-71-11].

## STEERING PUMP (CONT'D)

### Disassembly

Figure 20-90-4

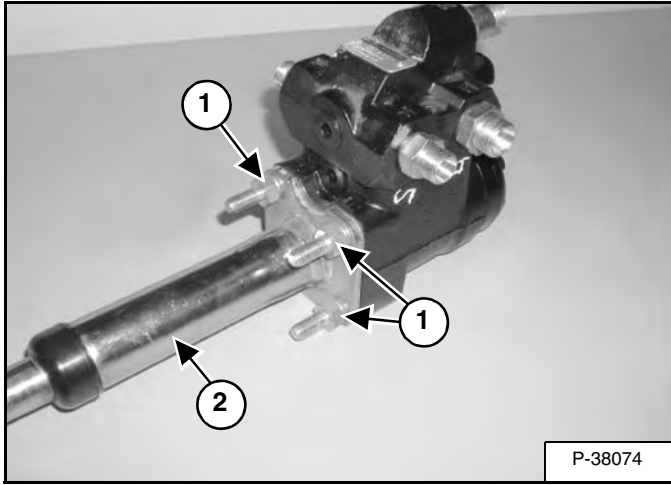

Remove the 4 nuts and washers (Item 1) and remove the steering shaft (Item 2) [Figure 20-90-4].

Figure 20-90-5

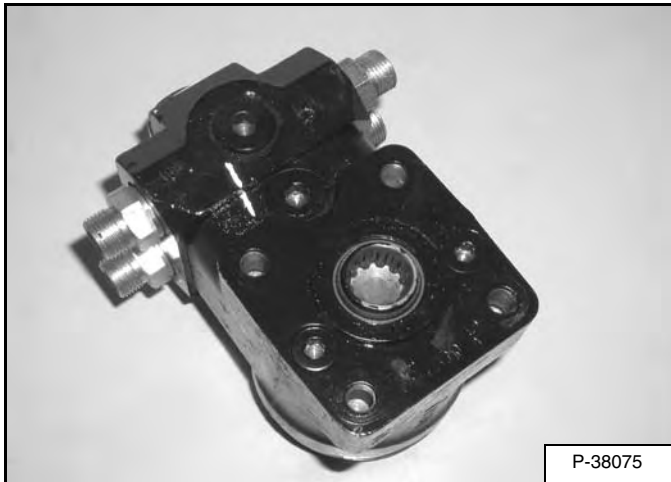

Mark the housing for correct assembly [Figure 20-90-5].

# IMPORTANT

When repairing hydrostatic and hydraulic systems, clean the work area before disassembly and keep all parts clean. Always use caps and plugs on hoses, tubelines and ports to keep dirt out. Dirt can quickly damage the system.

I-2003-0888

Figure 20-90-6

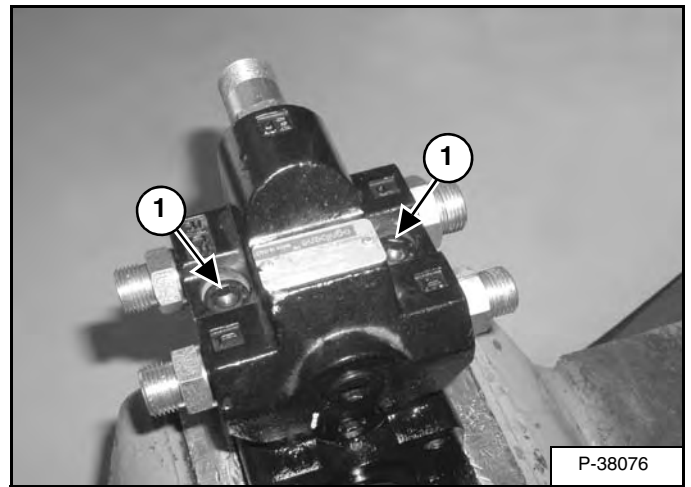

Remove the 2 priority valve mounting bolts (Item 1) [Figure 20-90-6].

Remove the priority valve.

Figure 20-90-7

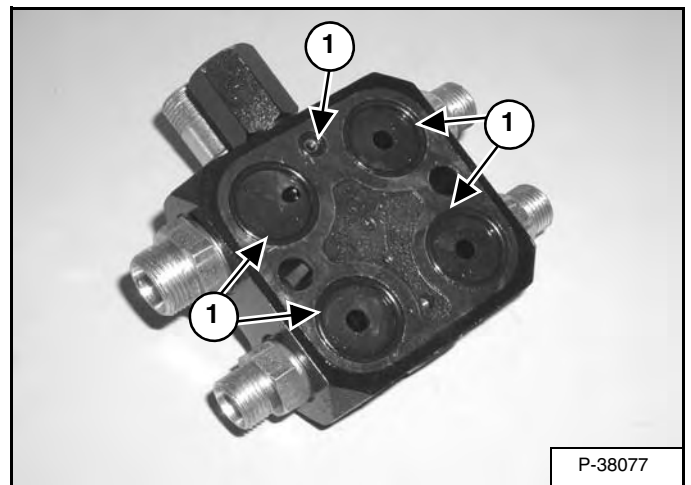

Remove the 5 O-rings (Item 1) [Figure 20-90-7] from the priority valve.

## STEERING PUMP (CONT'D)

### Assembly (Cont'd)

Figure 20-90-44

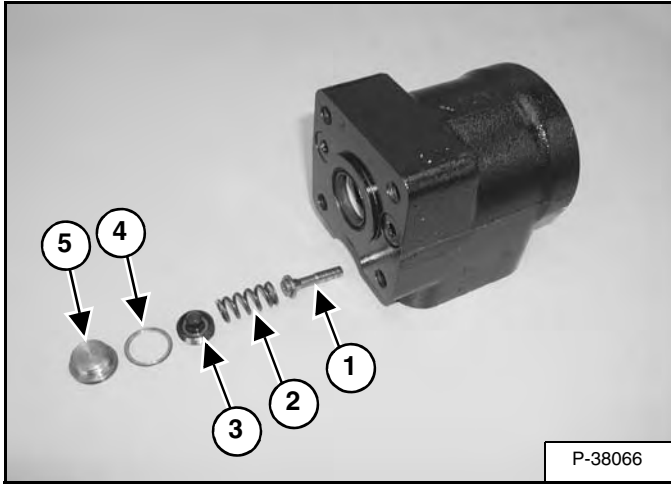

Install the poppet (Item 1), spring (Item 2), spring seat (Item 3), washer (Item 4) and plug (Item 5) [Figure 20-90-44] into the port.

Figure 20-90-45

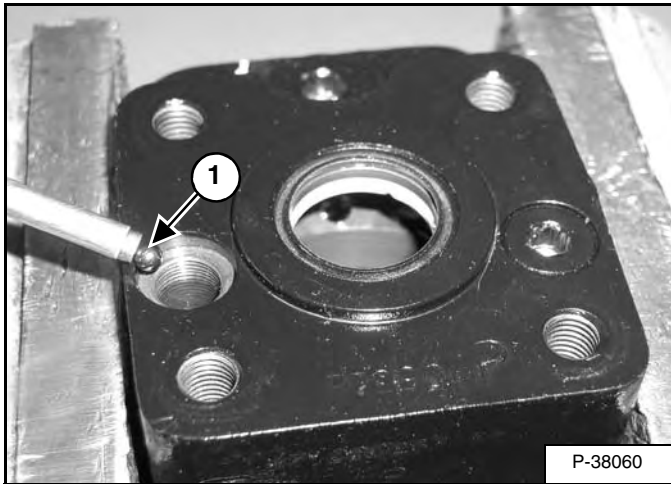

Install the check ball (Item 1) [Figure 20-90-45] into the port.

**NOTE:** The following procedures will be performed on the second port.

Figure 20-90-46

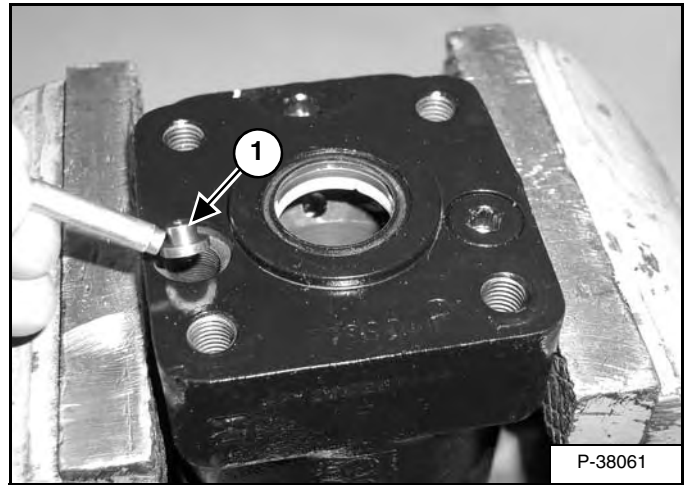

Install the poppet (Item 1) [Figure 20-90-46].

Figure 20-90-47

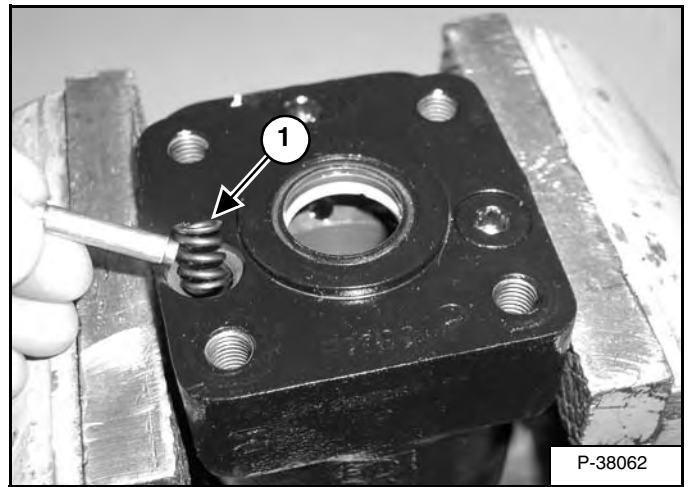

Install the spring (Item 1) [Figure 20-90-47].

## TRAVEL PEDAL (CONT'D)

### Disassembly And Assembly

Figure 20-100-3

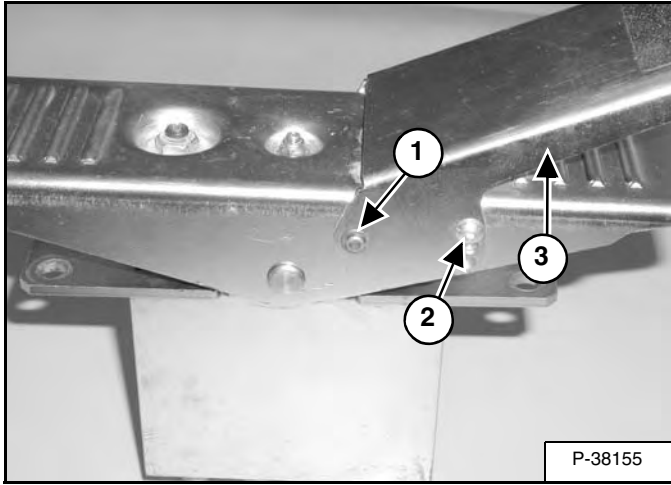

Remove the retainer clip and pin (Item 1) and bolt (Item 2) (both sides). Remove the pedal angle plate (Item 3) [Figure 20-100-3].

Figure 20-100-4

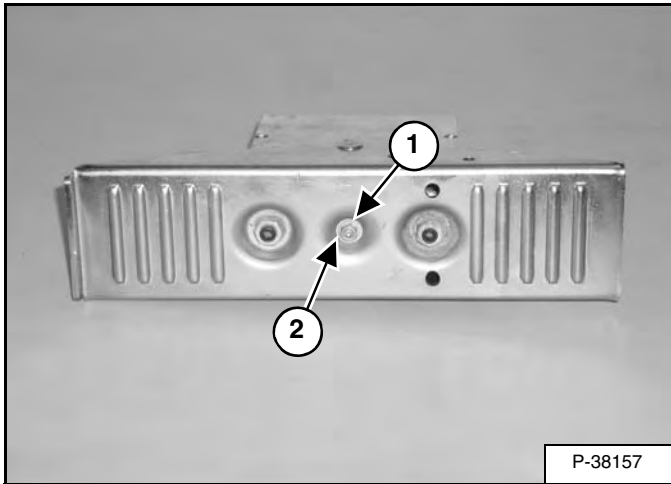

Loosen the locknut (Item 1) and set screw (Item 2) [Figure 20-100-4].

Figure 20-100-5

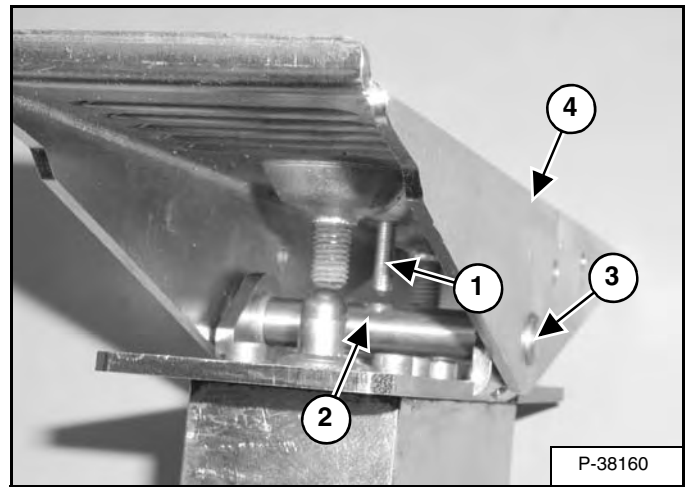

Back the set screw (Item 1) out of the pin (Item 2). Remove the pin (Item 3) and pedal (Item 4) [Figure 20-100-5].

**Installation:** Align the set screw (Item 1) with the hole in the pin (Item 2) [Figure 20-100-5].

Figure 20-100-6

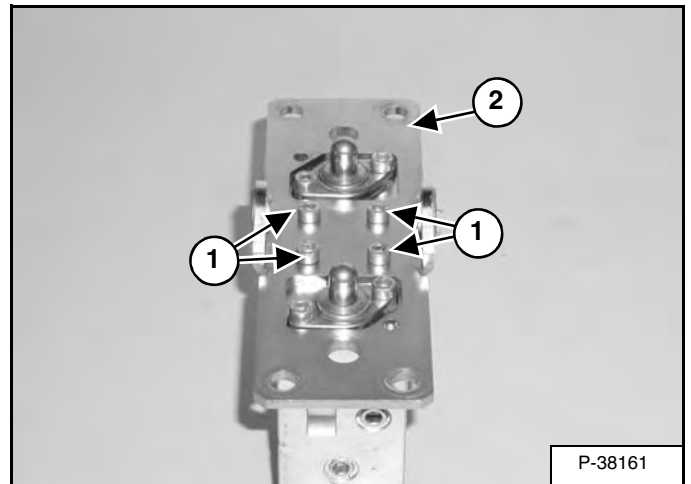

Remove the 4 bolts (Item 1) and the mount plate (Item 2) [Figure 20-100-6].

# SAPR BRAKE CYLINDER (CON'TD)

## Parts Identification

1. Dust Cover
2. Clevis
3. Nut
4. Housing
5. Spring
6. Piston/Rod Assembly
7. Seal
8. Backup Ring
9. O-ring
10. Fitting

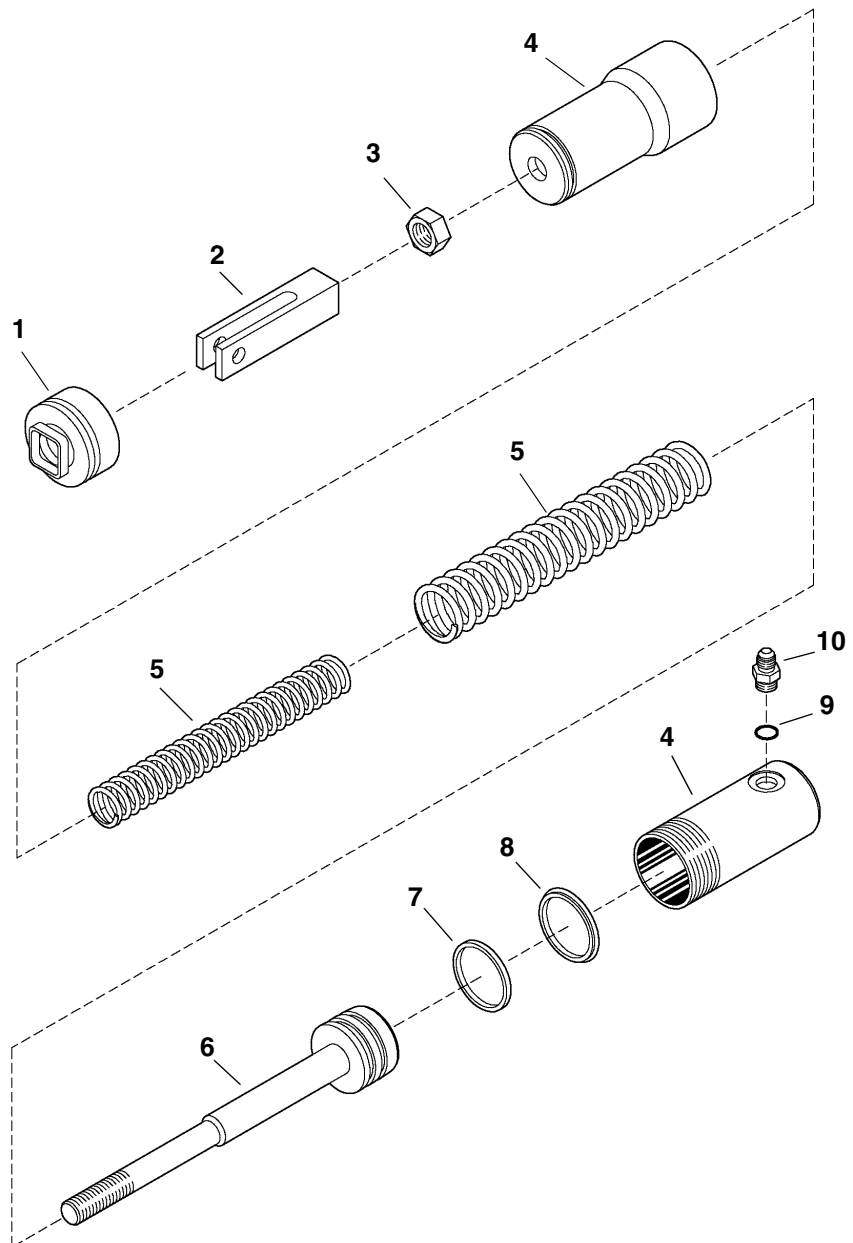

MS2109S

## AUXILIARY CONTROL VALVE

### Removal And Installation

Stop the engine, engage the parking brake.

Rotate the battery disconnect lever counterclockwise to disconnect the battery from the system.

Remove the rear floor panel. (See Rear Panel Removal And Installation on Page 50-30-2.)

# IMPORTANT

When repairing hydrostatic and hydraulic systems, clean the work area before disassembly and keep all parts clean. Always use caps and plugs on hoses, tubelines and ports to keep dirt out. Dirt can quickly damage the system.

I-2003-0888

Figure 20-130-1

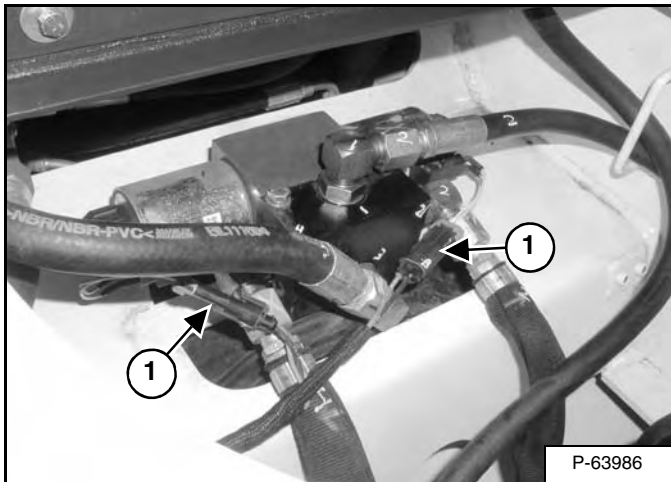

Disconnect the 2 harness connectors (Item 1) [Figure 20-130-1].

**NOTE:** Mark the harness connectors for correct installation.

Figure 20-130-2

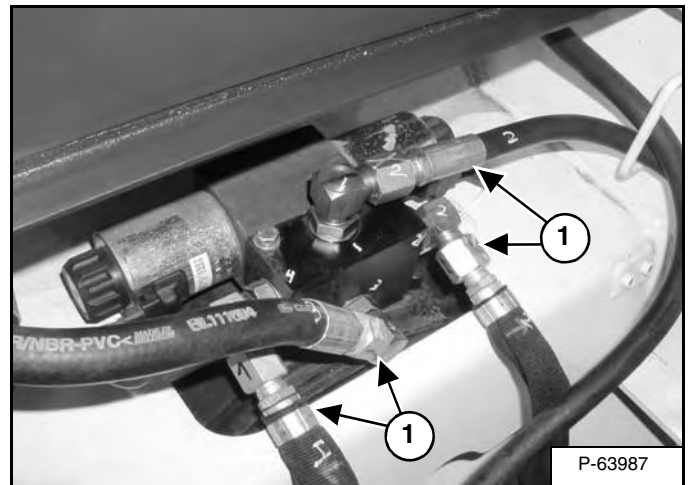

Remove the 4 hoses (Item 1) [Figure 20-130-2].

**NOTE:** Mark hoses for correct installation.

Figure 20-130-3

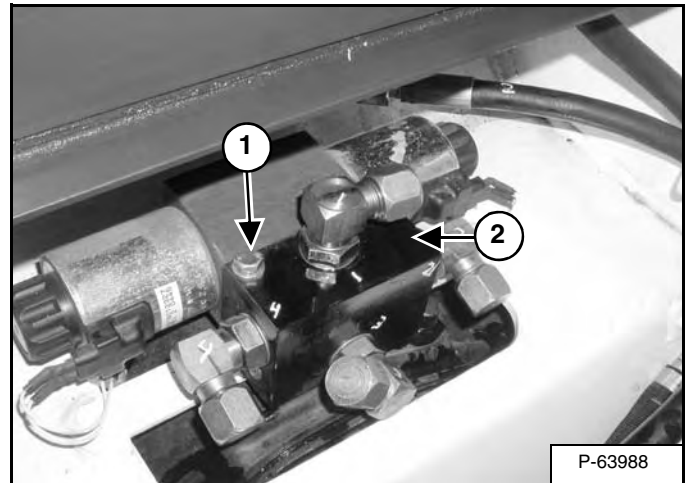

Remove the 2 bolts (Item 1) and control valve (Item 2) [Figure 20-130-3].

**Installation:** Tighten the bolts to 18 to 19 ft.-lb. (24 to 26 N•m) torque.

## OIL COOLER

### Removal And Installation

Raise the lift arms and install an approved lift arm support device. (See Installing The Approved Lift Arm Support Device on Page 10-20-1.)

Stop the engine, engage parking brake.

Rotate battery disconnect lever counterclockwise to disconnect battery from system.

Remove the grill. (See Removal And Installation on Page 50-40-1.)

Figure 30-20-1

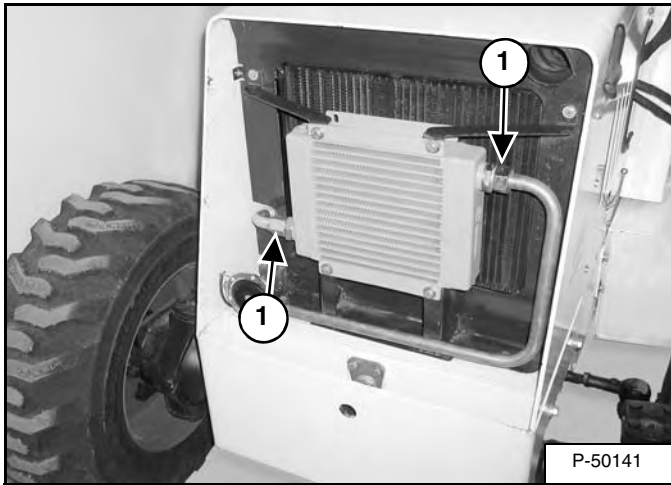

Remove the 2 tubelines (Item 1) [Figure 30-20-1].

**NOTE:** Mark oil cooler for correct installation.

## IMPORTANT

When making repairs on hydraulic system, clean the work area before disassemble and keep all parts clean. Always use caps and plugs on hoses, tubelines and ports to keep dirt out. Dirt can quickly damage the system.

I-2056-0793

Figure 30-20-2

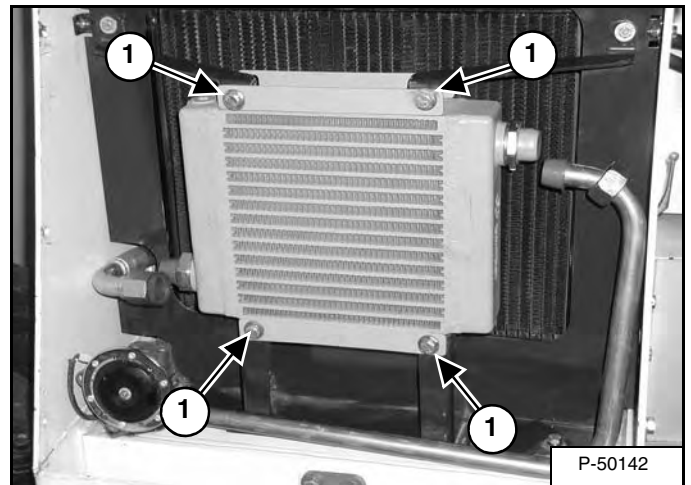

Remove the 4 bolts (Item 1) [Figure 30-20-2].

**Installation:** Tighten bolts to 18 to 19 ft.-lb. (24 to 26 N•m) torque.

Figure 30-20-3

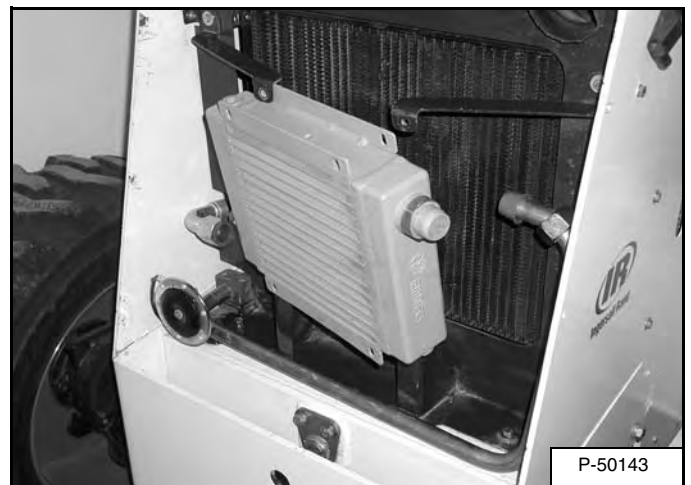

Remove the oil cooler [Figure 30-20-3].

## HYDROSTATIC DRIVE MOTOR (CONT'D)

### Inspection

Clean all parts in solvent and dry with compressed air. DO NOT use cloth or paper as small pieces of material can get into the system and cause damage.

**Figure 30-30-28**

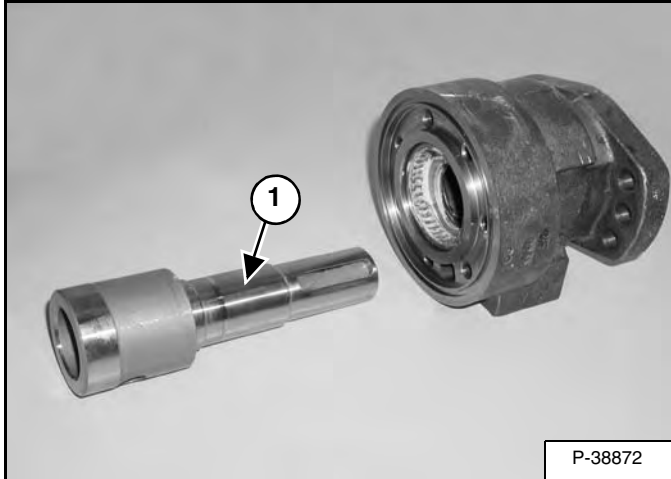

Check the coupling shaft (Item 1) [Figure 30-30-28] for wear or damage in the spline and bearing surface areas. Replace as needed.

**Figure 30-30-29**

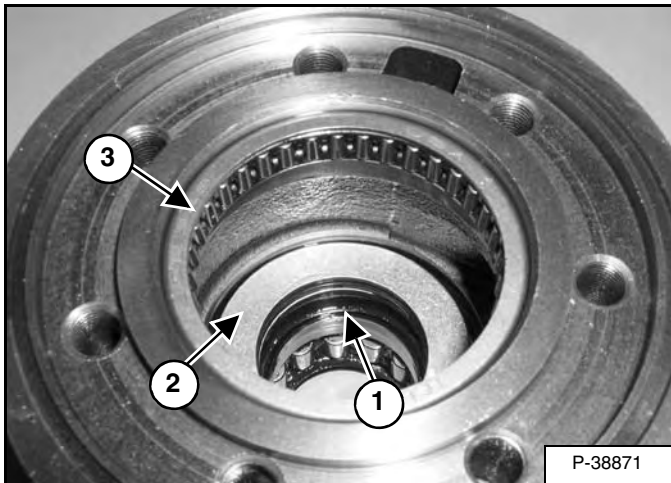

Inspect the shaft seal (Item 1), thrust bearing (Item 2) and needle bearing (Item 3) [Figure 30-30-29] replace as needed.

**Figure 30-30-30**

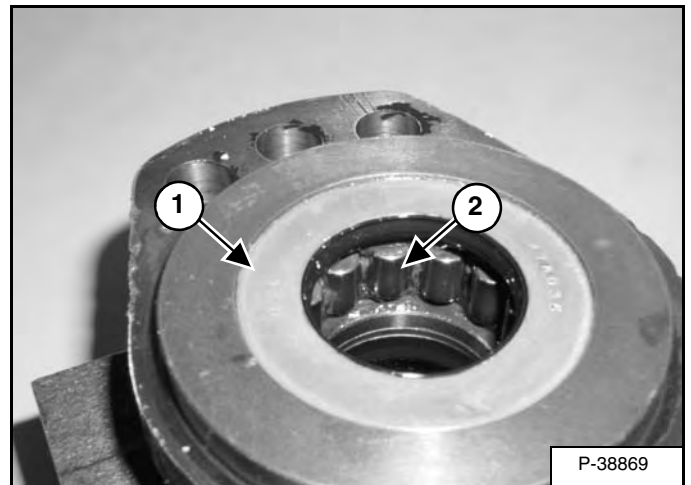

Inspect the outer shaft seal (Item 1) and roller bearing (Item 2) [Figure 30-30-30] replace as needed.

**Figure 30-30-31**

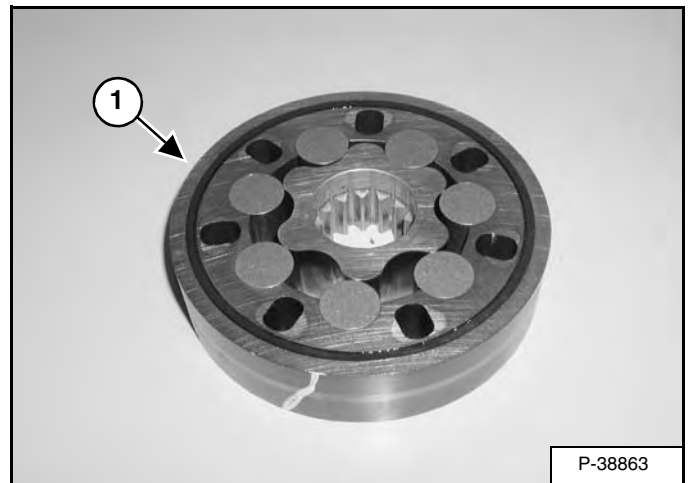

Check rotor assembly (Item 1) [Figure 30-30-31] for wear scratches or cracks. If there is any defect in the rotor assembly, the assembly must be replaced.

## HYDROSTATIC PUMP

### Description

The hydrostatic pump is a variable displacement, bidirectional axial piston pump, with swash plate system.

Flow rate is proportional to rotation speed and displacement.

Flow rate increases as the servo piston moves the swash plate from neutral to a maximum position creating either forward or reverse drive motor rotation.

### Removal And Installation

## WARNING

Hydraulic fluid escaping under pressure can have sufficient force to enter a person's body by penetrating the skin. This can cause serious injury and possible death if proper medical treatment by a physician familiar with this injury is not received immediately.

W-2145-0290

## IMPORTANT

When making repairs on hydraulic system, clean the work area before disassemble and keep all parts clean. Always use caps and plugs on hoses, tubelines and ports to keep dirt out. Dirt can quickly damage the system.

I-2056-0793

Drain the hydraulic reservoir. (See HYDRAULIC FLUID RESERVOIR on Page 20-70-1.)

Remove the front floor panels. (See FLOOR PANELS on Page 50-30-1.)

Remove the gear pump. (See Removal And Installation on Page 20-80-1.)

Figure 30-40-1

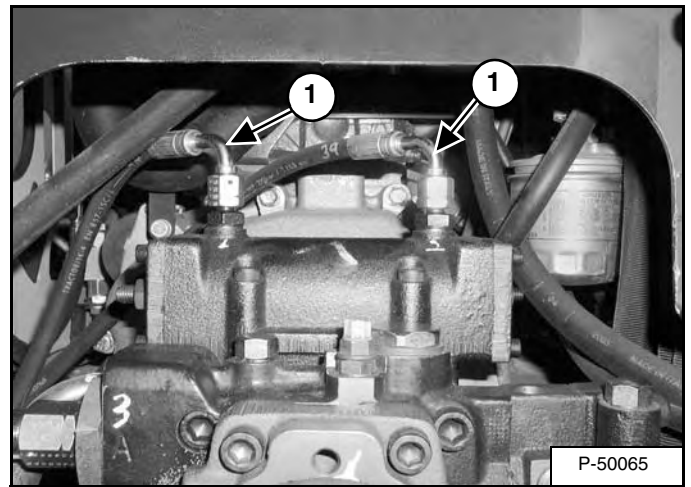

Remove the 2 hoses (Item 1) [Figure 30-40-1].

**NOTE:** Mark the hoses for correct assembly.

Figure 30-40-2

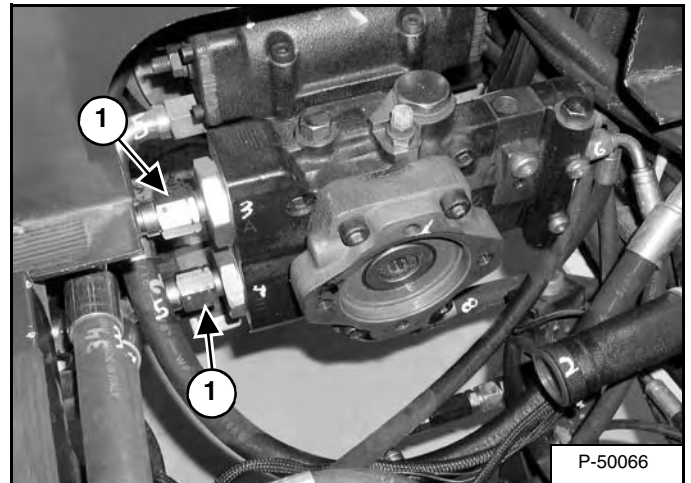

Remove the 2 hoses (Item 1) [Figure 30-40-2].

## HYDROSTATIC PUMP (CONT'D)

### Disassembly (Cont'd)

Figure 30-40-29

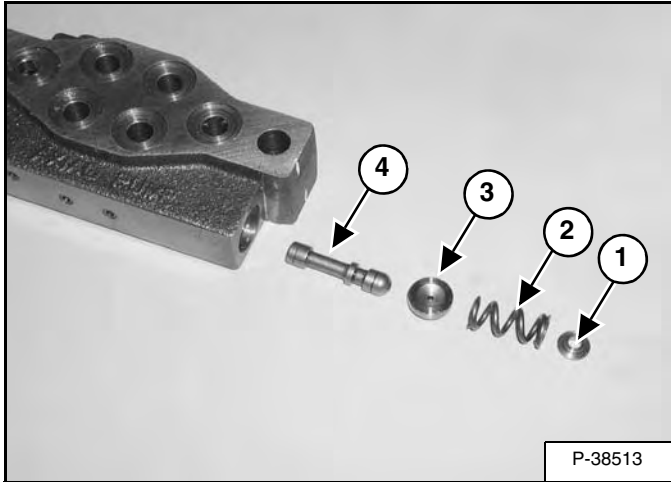

Remove the spring seat (Item 1), spring (Item 2), spring seat/orifice (Item 3) and spool (Item 4) [Figure 30-40-29].

Figure 30-40-30

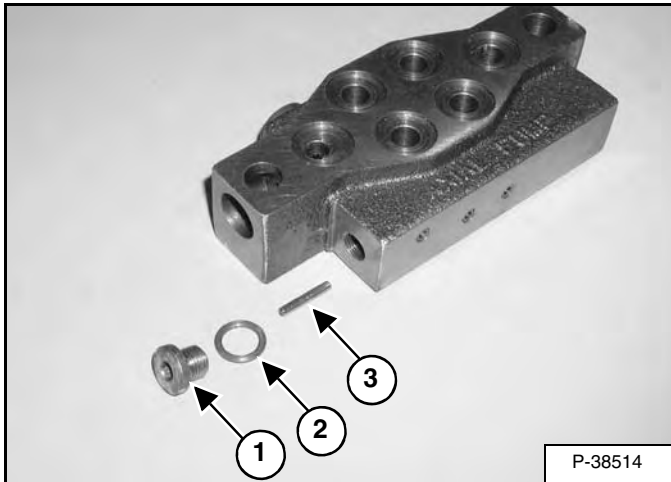

Remove the plug (Item 1) washer (Item 2) and pin (Item 3) [Figure 30-40-30].

Figure 30-40-31

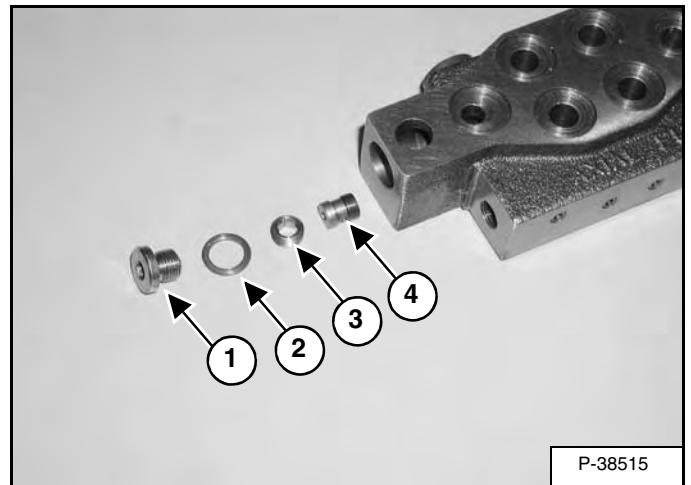

Remove the plug (Item 1) washer (Item 2), retainer (Item 3) and check valve assembly (Item 4) [Figure 30-40-31].

Figure 30-40-32

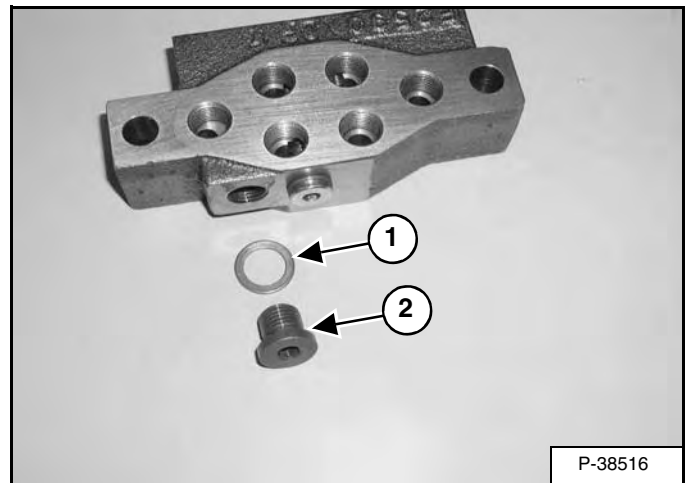

Remove the plug (Item 1) and washer (Item 2) [Figure 30-40-32].

## HYDROSTATIC PUMP (CONT'D)

### Disassembly (Cont'd)

Figure 30-40-69

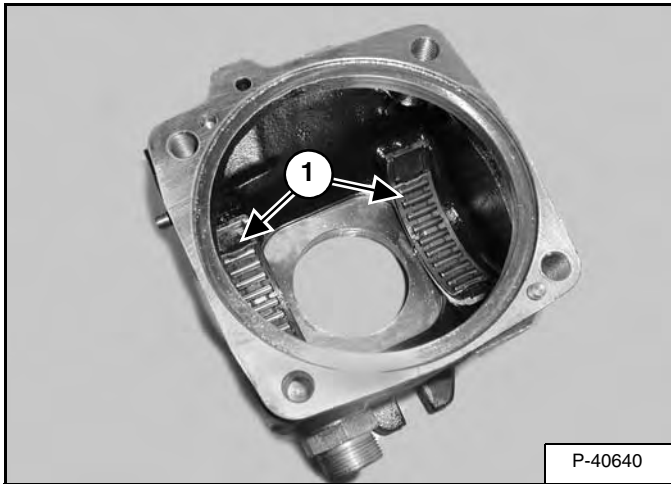

Remove the swash plate bearings (Item 1) [Figure 30-40-69].

Figure 30-40-70

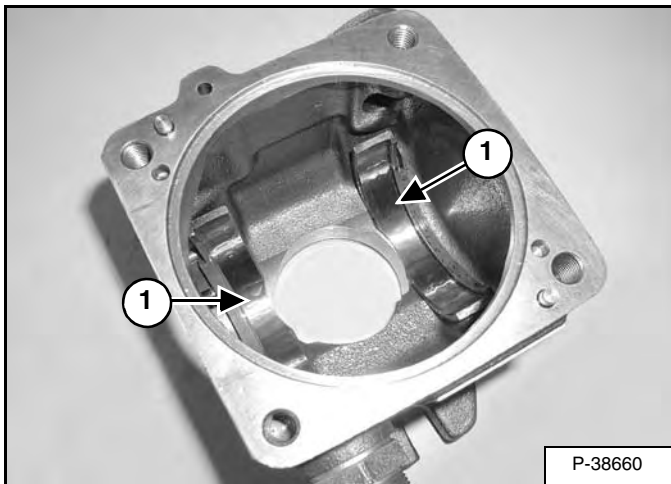

Remove the swash plate bearing races (Item 1) [Figure 30-40-70].

Figure 30-40-71

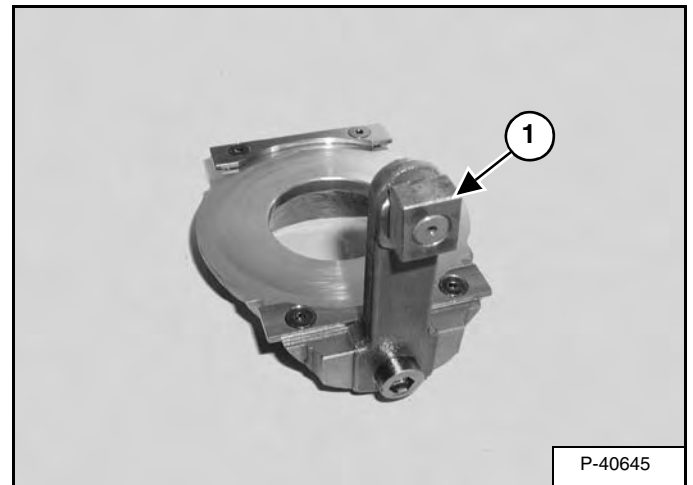

Remove the actuator block (Item 1) [Figure 30-40-71] from the swash plate arm.

## HYDROSTATIC PUMP (CONT'D)

### Assembly (Cont'd)

Figure 30-40-107

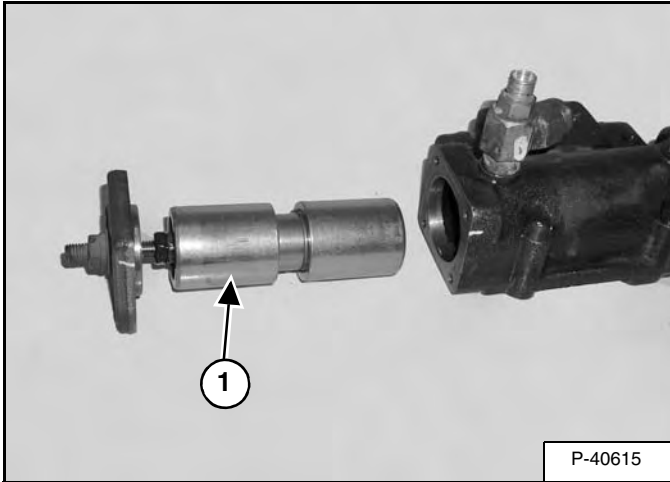

Lightly lubricate the back-up rings in the housing and install the servo piston (Item 1) [Figure 30-40-107] into the housing.

Figure 30-40-108

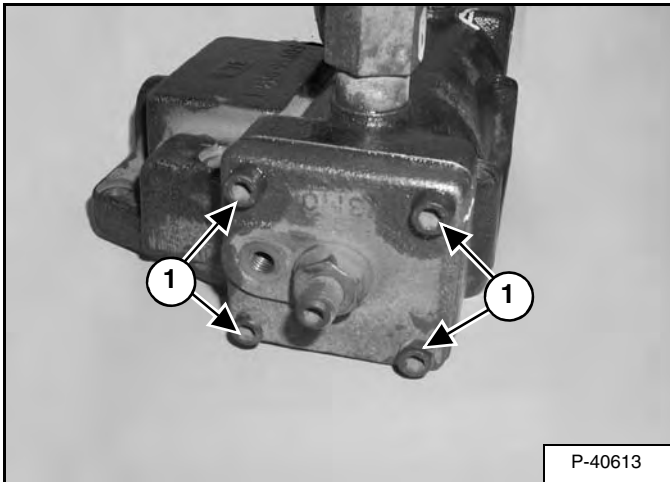

Install the 4 mounting bolts (Item 1) [Figure 30-40-108] and tighten on both end caps.

Figure 30-40-109

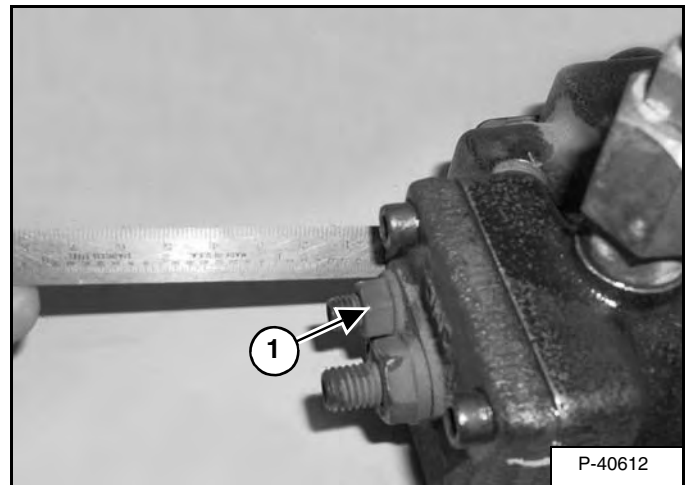

Install the servo adjustment screw (Item 1) [Figure 30-40-109] into the housing to the correct adjustment recorded earlier.

Figure 30-40-110

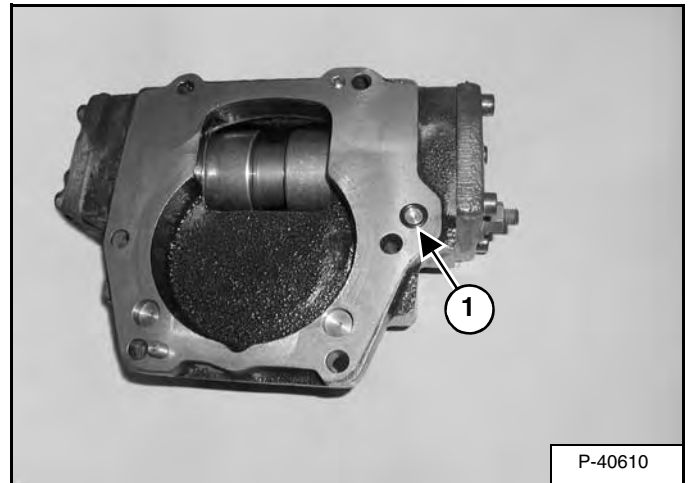

Install the new O-ring (Item 1) [Figure 30-40-110] onto the servo housing.

## **HYDROSTATIC PUMP TESTING AND ADJUSTMENT (CONT'D)**

### **Hydrostatic Pump Work Sheet (Cont'd)**

#### **III. FORWARD TRAVEL PRESSURE/TORQUE LIMITER ADJUSTMENT**

31. Locate the torque limiter on the bottom right side of the hydrostatic pump.
32. With the engine OFF, loosen the jam nut and turn the adjustment screw clockwise 2 full turns.
33. With the parking brake engaged, start the engine and press the Press To Drive button.
34. Set the engine to full RPM.
35. Operate the travel pedal in the forward travel position and record the highest pressure on the 10,000 PSI (690 bar) gauge.

#### **\_\_\_\_\_ FORWARD TRAVEL PRESSURE**

36. With the engine running turn the torque limiter adjustment screw counterclockwise until the forward travel pressure is reduced by approximately 100 PSI (6.9 bar).
37. Tighten the jam nut.
38. Stop the engine.
39. Remove pressure gauges.
40. Install plugs.
41. Install left front floor panel.
42. Raise machine and remove jackstands.

## PARKING BRAKE (CONT'D)

### Cable Removal And Installation (Cont'd)

Figure 40-10-9

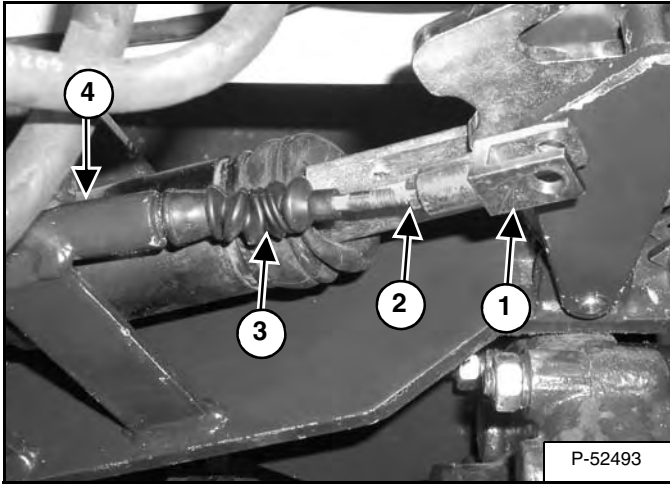

Remove the clevis (Item 1), jam nut (Item 2) and dust cover (Item 3). Pull the cable through the bracket (Item 4) [Figure 40-10-9].

Figure 40-10-10

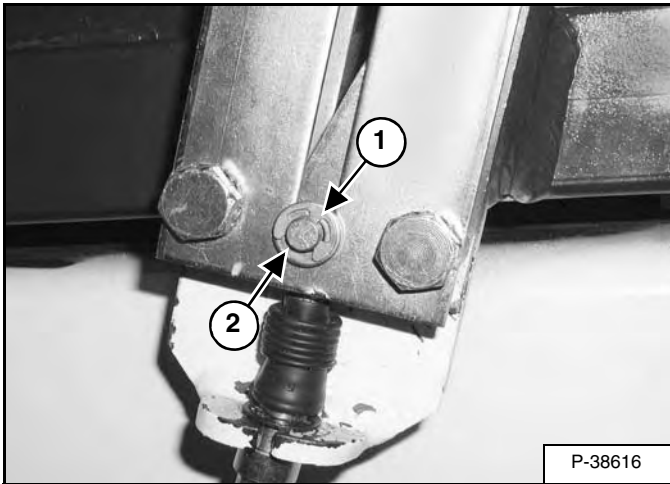

Remove the pin retainer clip (Item 1) and washer (Item 2) [Figure 40-10-10].

Figure 40-10-11

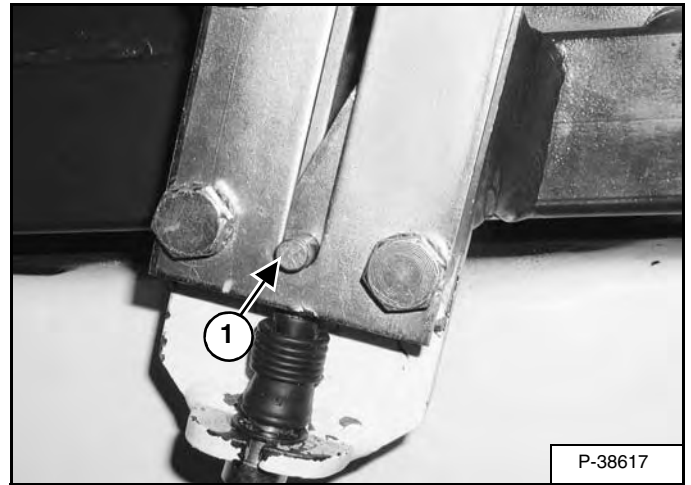

Remove the pin (Item 1) [Figure 40-10-11].

Figure 40-10-12

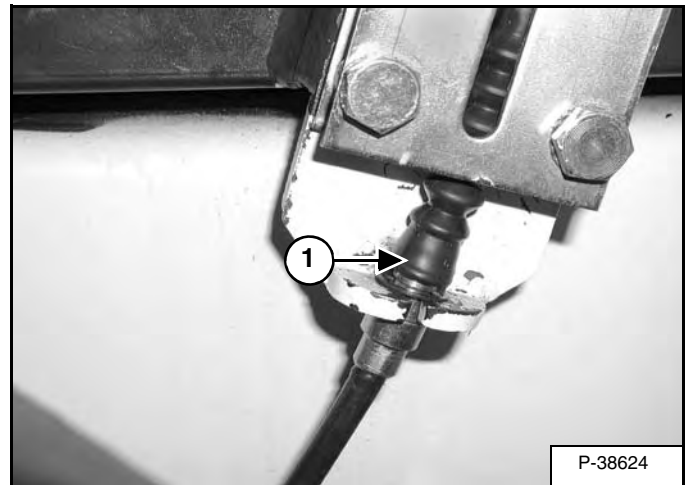

Raise the cable boot (Item 1) [Figure 40-10-12].

## REAR AXLE

### Removal

Stop the engine, engage the parking brake.

Remove the front floor panel. (See FLOOR PANELS on Page 50-30-1.)

Figure 40-30-1

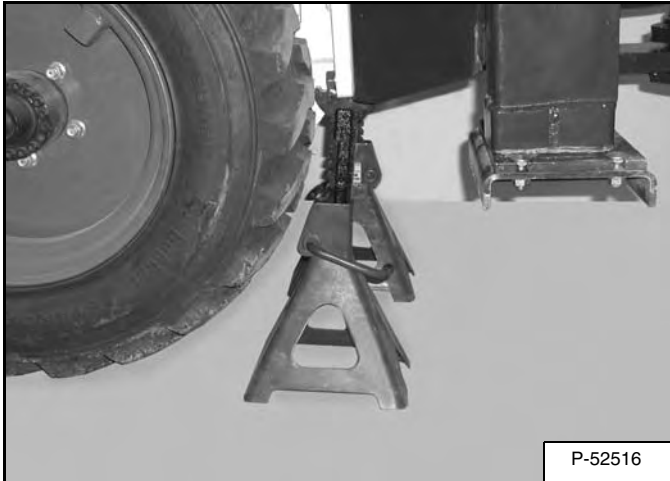

Raise the rear of the machine and install jackstands on the rear of the loader backhoe frame [Figure 40-30-1].

Remove the driveshaft. (See Removal And Installation on Page 40-50-1.)

Figure 40-30-2

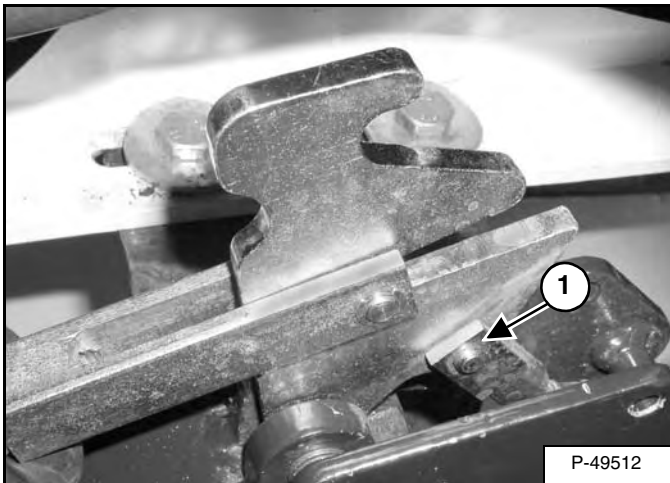

Remove the retainer clip and pin (Item 1) [Figure 40-30-2] from the caliper linkage bell crank.

Figure 40-30-3

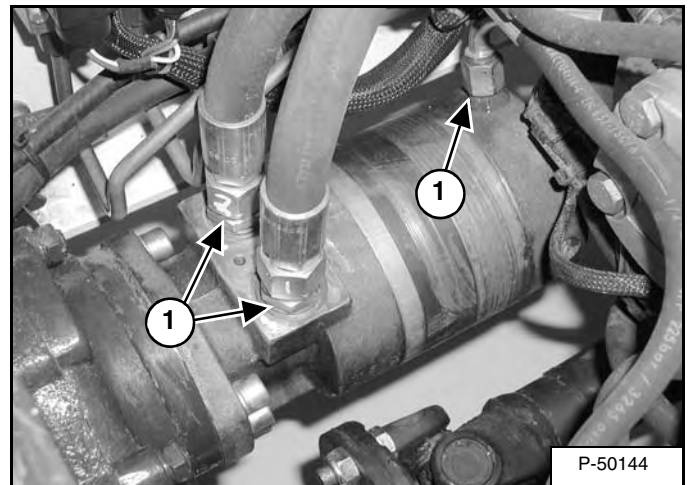

Remove the 3 hoses (Item 1) [Figure 40-30-3] from the drive motor.

**NOTE:** Mark hoses for correct assembly.

## IMPORTANT

When repairing hydrostatic and hydraulic systems, clean the work area before disassembly and keep all parts clean. Always use caps and plugs on hoses, tubelines and ports to keep dirt out. Dirt can quickly damage the system.

I-2003-0888

Figure 40-30-4

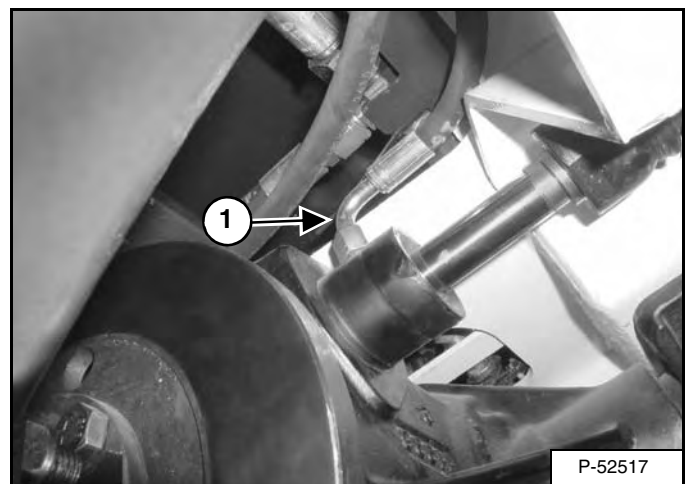

Remove the left hose (Item 1) [Figure 40-30-4] from the steering cylinder.

CLICK HERE TO **DOWNLOAD** THE COMPLETE MANUAL

- Thank you very much for reading the preview of the manual.
- You can download the complete manual from: [www.heydownloads.com](http://www.heydownloads.com) by clicking the link below



- Please note: If there is no response to CLICKING the link, please download this PDF first and then click on it.

CLICK HERE TO **DOWNLOAD** THE COMPLETE MANUAL

## AXLE AND DIFFERENTIAL (REAR) (CONT'D)

### Wheel Hub/Spindle Disassembly (Cont'd)

Figure 40-31-9

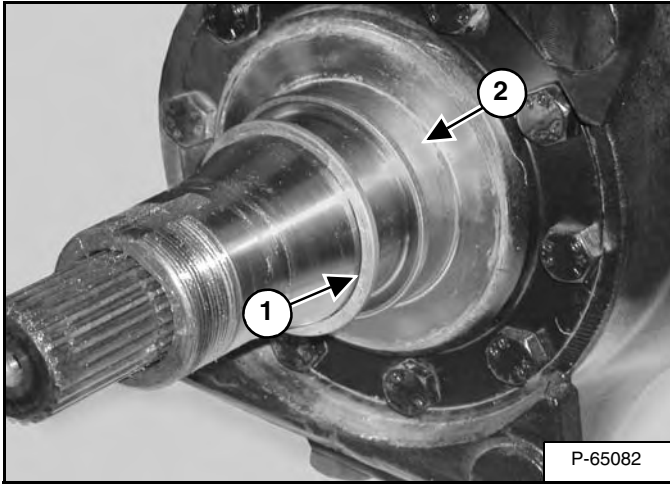

Remove the spacer ring (Item 1) [Figure 40-31-9] from the spindle.

**NOTE:** The spacer ring may come off when the hub assembly is removed.

Remove the bushing (Item 2) [Figure 40-31-9] if worn or damaged.

Figure 40-31-10

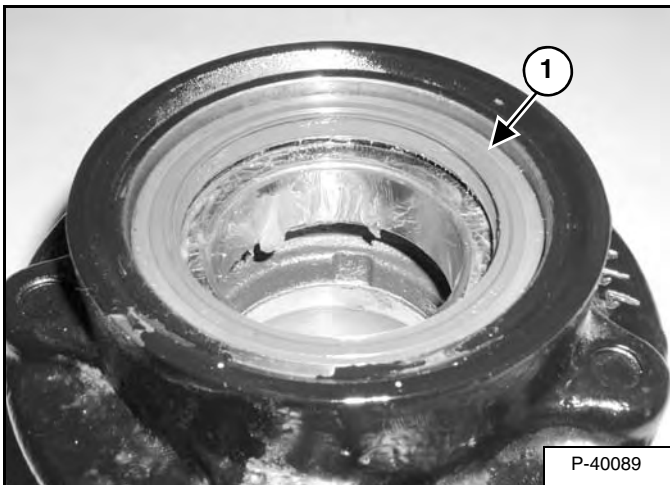

Remove the seal (Item 1) [Figure 40-31-10] from the hub.

Figure 40-31-11

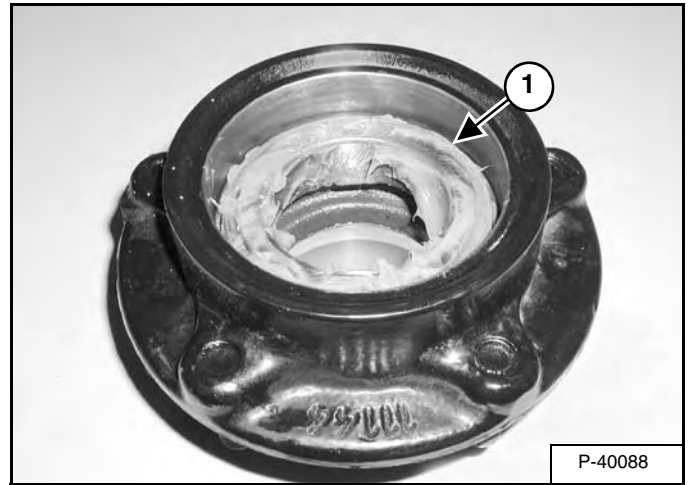

Remove the inner bearing (Item 1) [Figure 40-31-11].

Figure 40-31-12

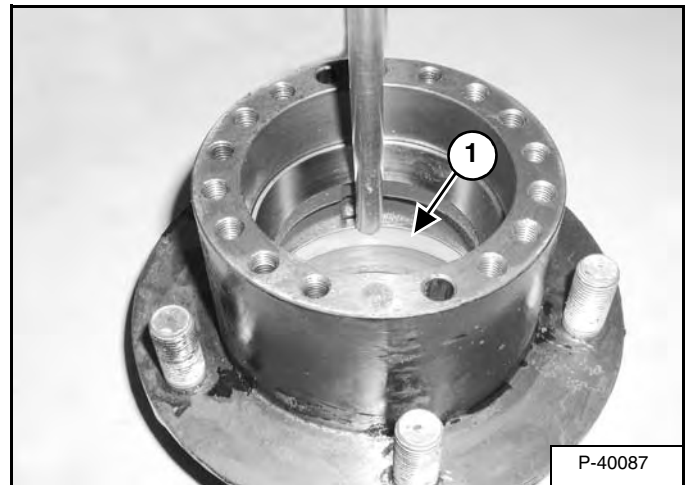

Remove the inner race (Item 1) [Figure 40-31-12].

# AXLE AND DIFFERENTIAL (REAR) (CONT'D)

## Differential Parts identification

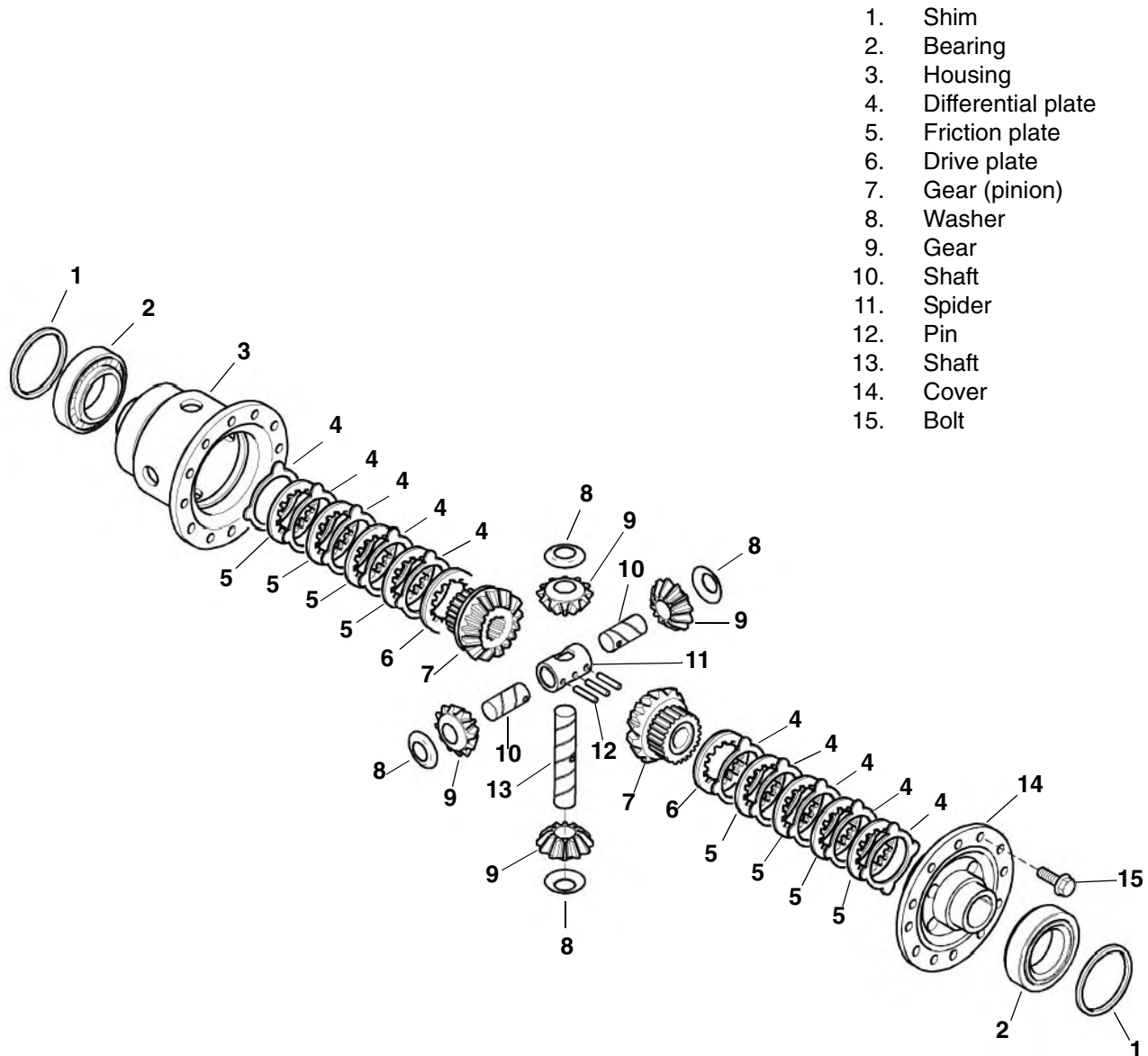

- 1. Shim
- 2. Bearing
- 3. Housing
- 4. Differential plate
- 5. Friction plate
- 6. Drive plate
- 7. Gear (pinion)
- 8. Washer
- 9. Gear
- 10. Shaft
- 11. Spider
- 12. Pin
- 13. Shaft
- 14. Cover
- 15. Bolt

B-23367

**AXLE AND DIFFERENTIAL (REAR) (CONT'D)**

**Pinion Group Disassembly (Cont'd)**

**Figure 40-31-68**

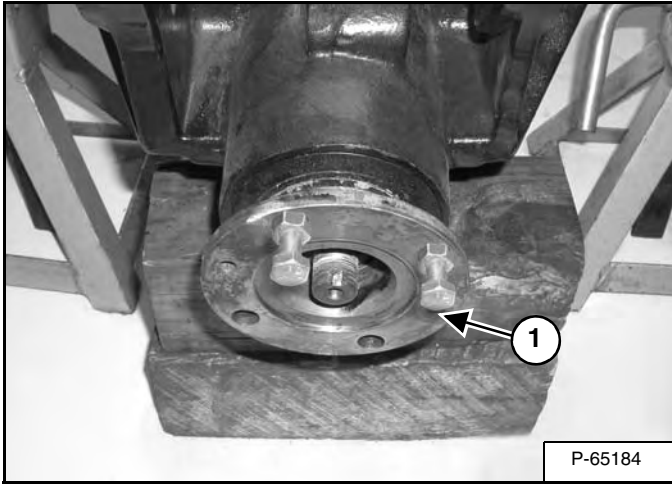

Remove the drive flange (Item 1) [Figure 40-31-68].

**Figure 40-31-69**

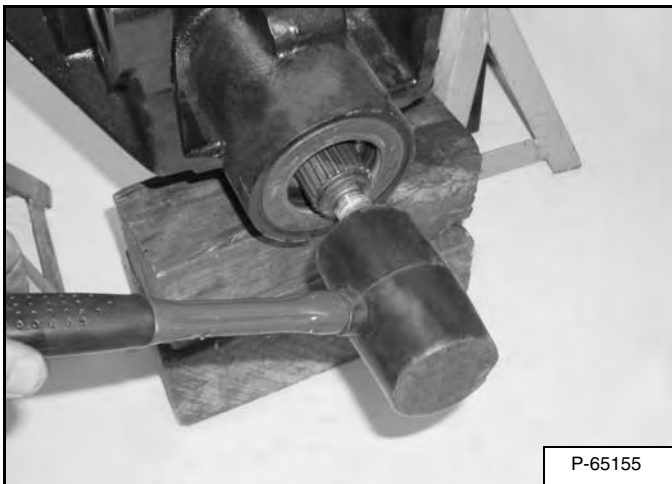

Support the back of the pinion shaft and remove from the housing using a soft hammer [Figure 40-31-69].

**Figure 40-31-70**

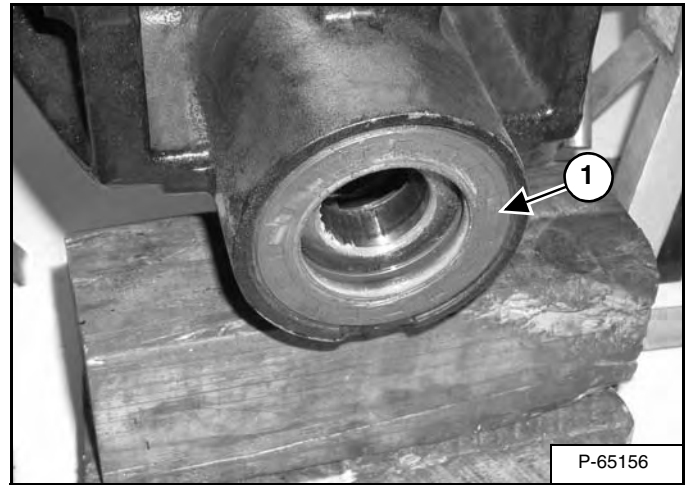

Remove and discard the seal (Item 1) [Figure 40-31-70].

**Figure 40-31-71**

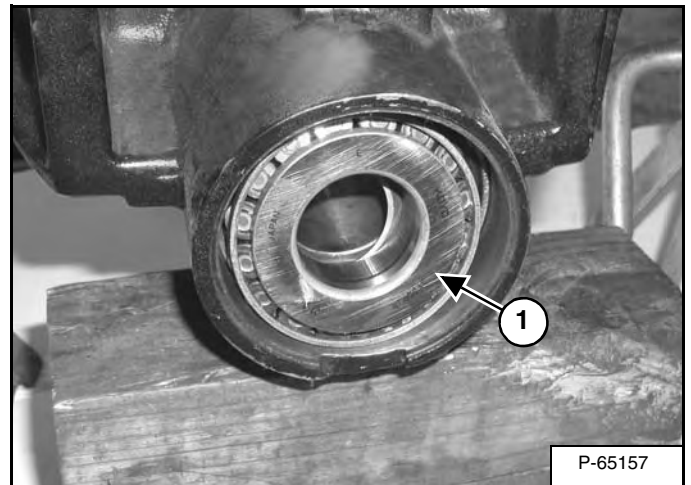

Remove the bearing (Item 1) [Figure 40-31-71].

## AXLE AND DIFFERENTIAL (REAR) (CONT'D)

### Differential Assembly

Figure 40-31-103

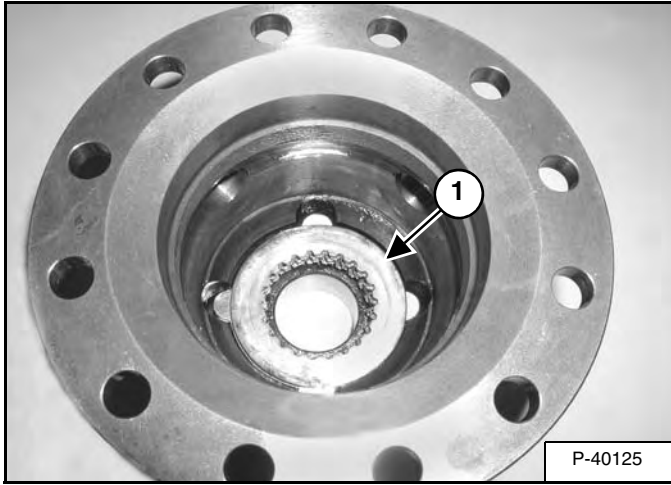

Install the plates (Item 1) [Figure 40-31-103] into the housing, beginning with a steel drive plate and alternating between steel and friction.

**NOTE: The thick washer must be on top (next to gear).**

Figure 40-31-104

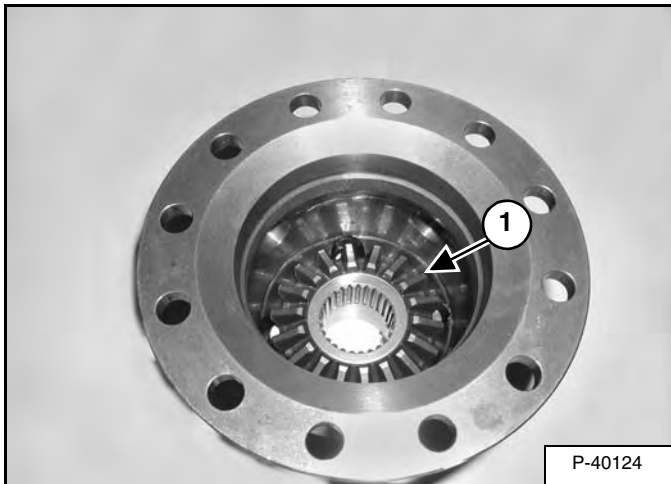

Install the pinion gear (Item 1) [Figure 40-31-104] onto the plate assembly.

**NOTE: Make sure the plates remain in the correct position.**

Figure 40-31-105

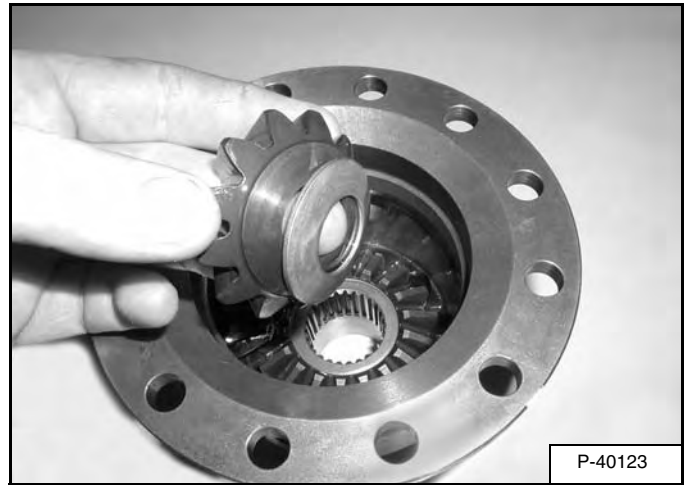

Install the side gear/thrust washer (both sides) [Figure 40-31-105].

Figure 40-31-106

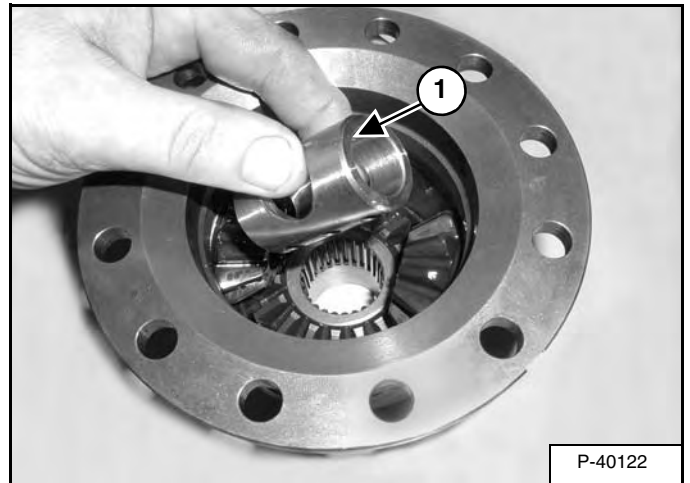

Install the spider shaft (Item 1) [Figure 40-31-106] between the side gears.

## AXLE AND DIFFERENTIAL (REAR) (CONT'D)

### Steering Knuckle Assembly (Cont'd)

Figure 40-31-138

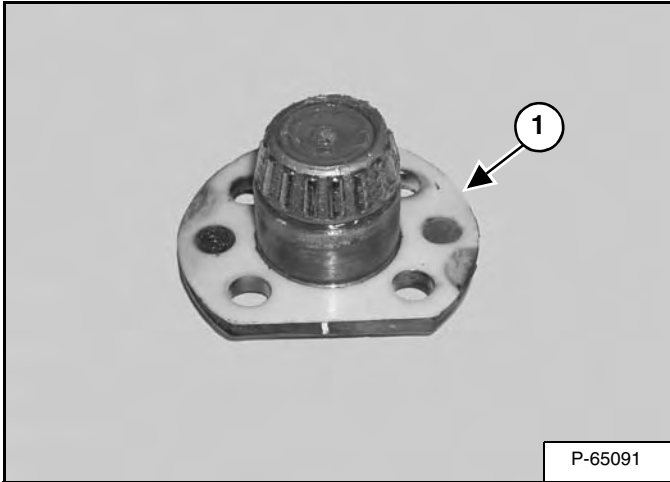

Install the shims (Item 1) [Figure 40-31-138] removed earlier, onto the lower king pin.

Figure 40-31-139

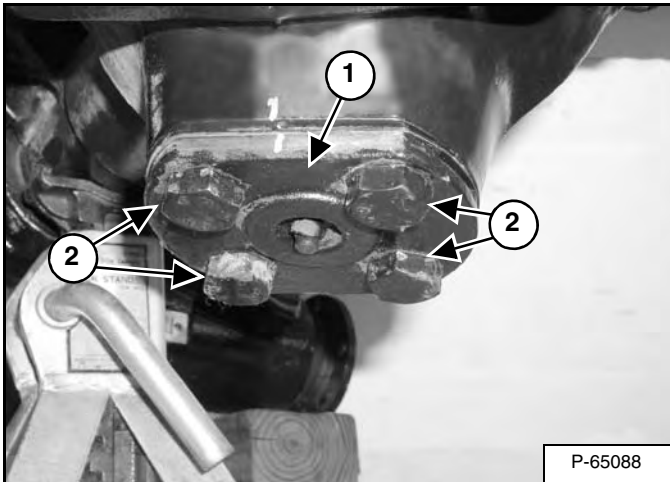

Install the lower king pin (Item 1) using the 4 bolts (Item 2) [Figure 40-31-139]. Do not tighten the bolts at this time.

Figure 40-31-140

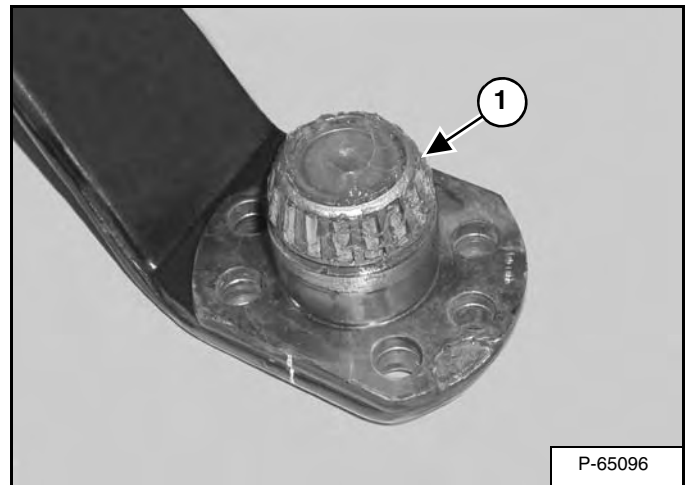

Lubricate and install the bearing (Item 1) [Figure 40-31-140] onto the upper king pin/arm.

Figure 40-31-141

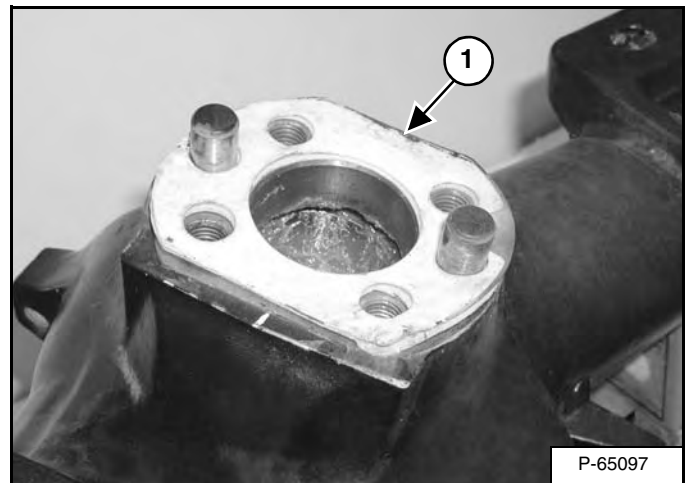

Install the shims (Item 1) [Figure 40-31-141].

## STEERING ANGLE ADJUSTMENT (REAR AXLE)

### Adjustment

The axle is removed from the machine for photo clarity, but this procedure may be completed with the axle installed in the machine.

Figure 40-32-1

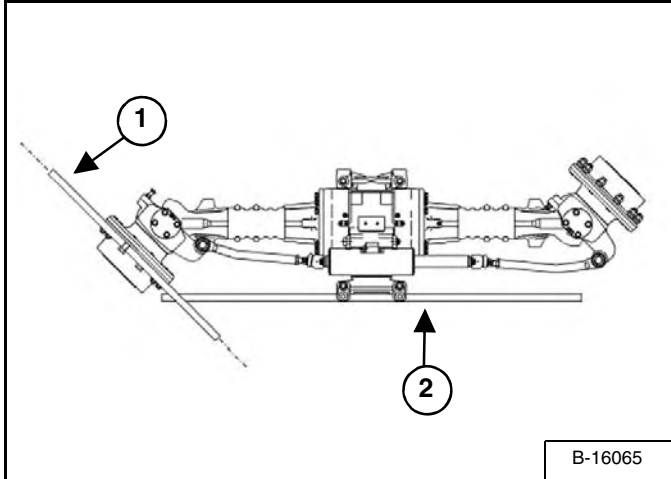

Install the identical, straight bars (Item 1) onto the wheel hub and secure them using lug nuts. Turn the steering wheel completely to one side. Place a straight bar (Item 2) [Figure 40-32-1] on the pinion shaft.

Figure 40-32-2

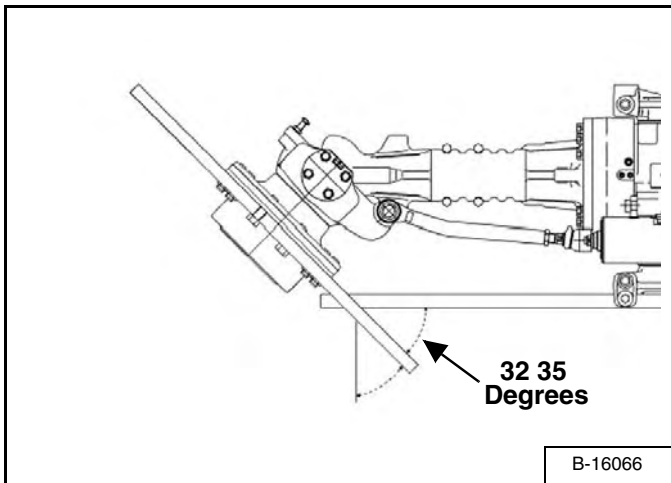

Using an angle gauge, adjust the bolt (Item 1) [Figure 40-32-3] to obtain a reading of between 32 to 35 degrees [Figure 40-32-2].

Figure 40-32-3

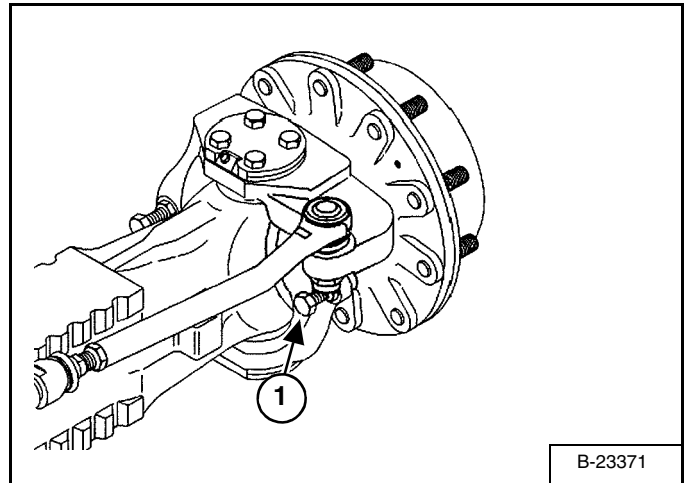

Adjust the stop (Item 1) [Figure 40-32-3] as needed. Tighten the lock nut to 110 ft.-lb. (50 N•m) torque.

Figure 40-32-4

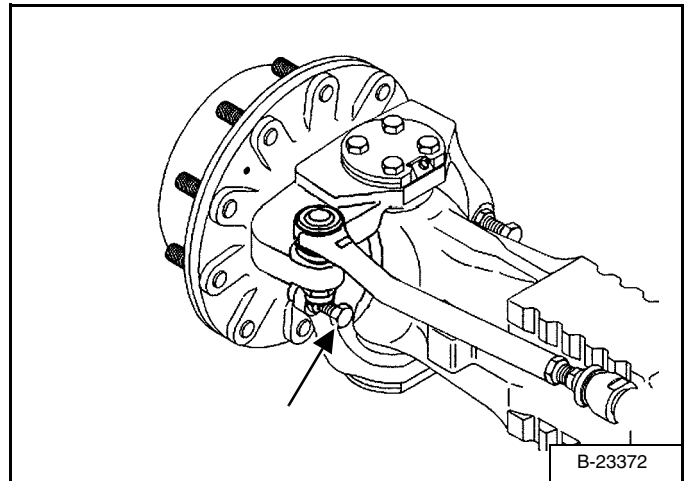

Turn the steering wheel completely to the other side [Figure 40-32-4] and repeat above procedure.

## AXLE AND DIFFERENTIAL (FRONT) (CONT'D)

### Wheel Hub/Spindle Disassembly (Cont'd)

Figure 40-41-9

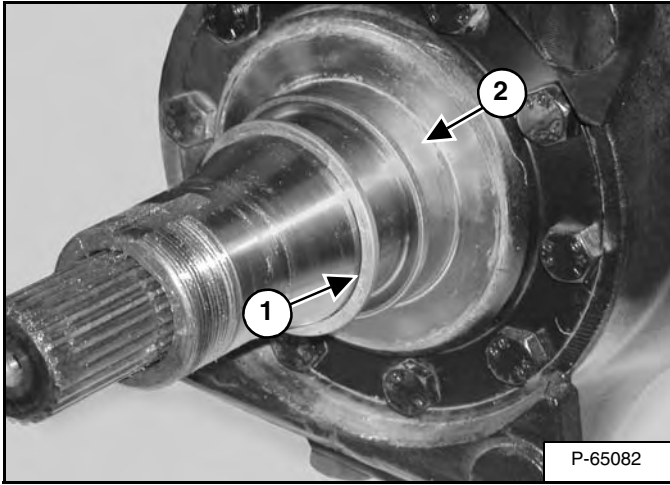

Remove the spacer ring (Item 1) [Figure 40-41-9] from the spindle.

**NOTE:** The spacer ring may come off when the hub assembly is removed.

Remove the bushing (Item 2) [Figure 40-41-9] if worn or damaged.

Figure 40-41-10

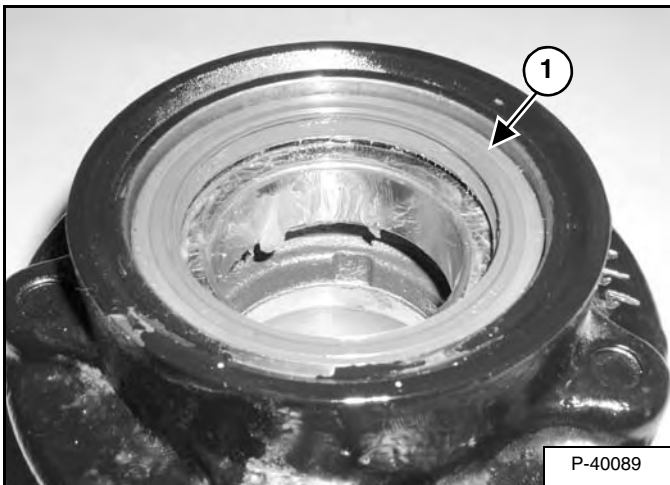

Remove the seal (Item 1) [Figure 40-41-10] from the hub.

Figure 40-41-11

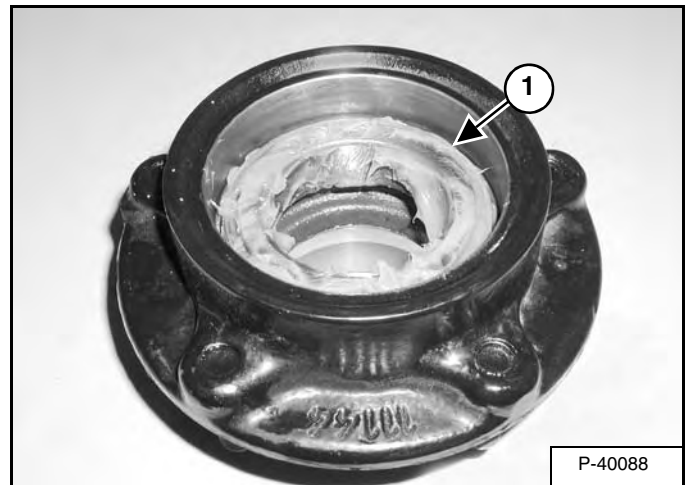

Remove the inner bearing (Item 1) [Figure 40-41-11].

Figure 40-41-12

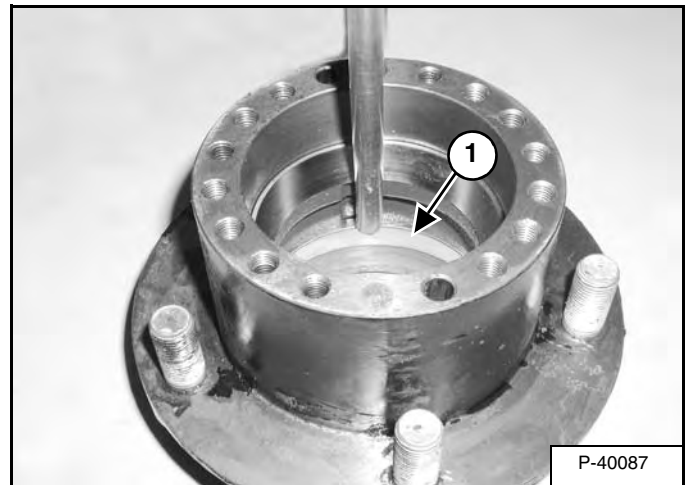

Remove the inner race (Item 1) [Figure 40-41-12].

# AXLE AND DIFFERENTIAL (FRONT) (CONT'D)

## Differential Parts Identification

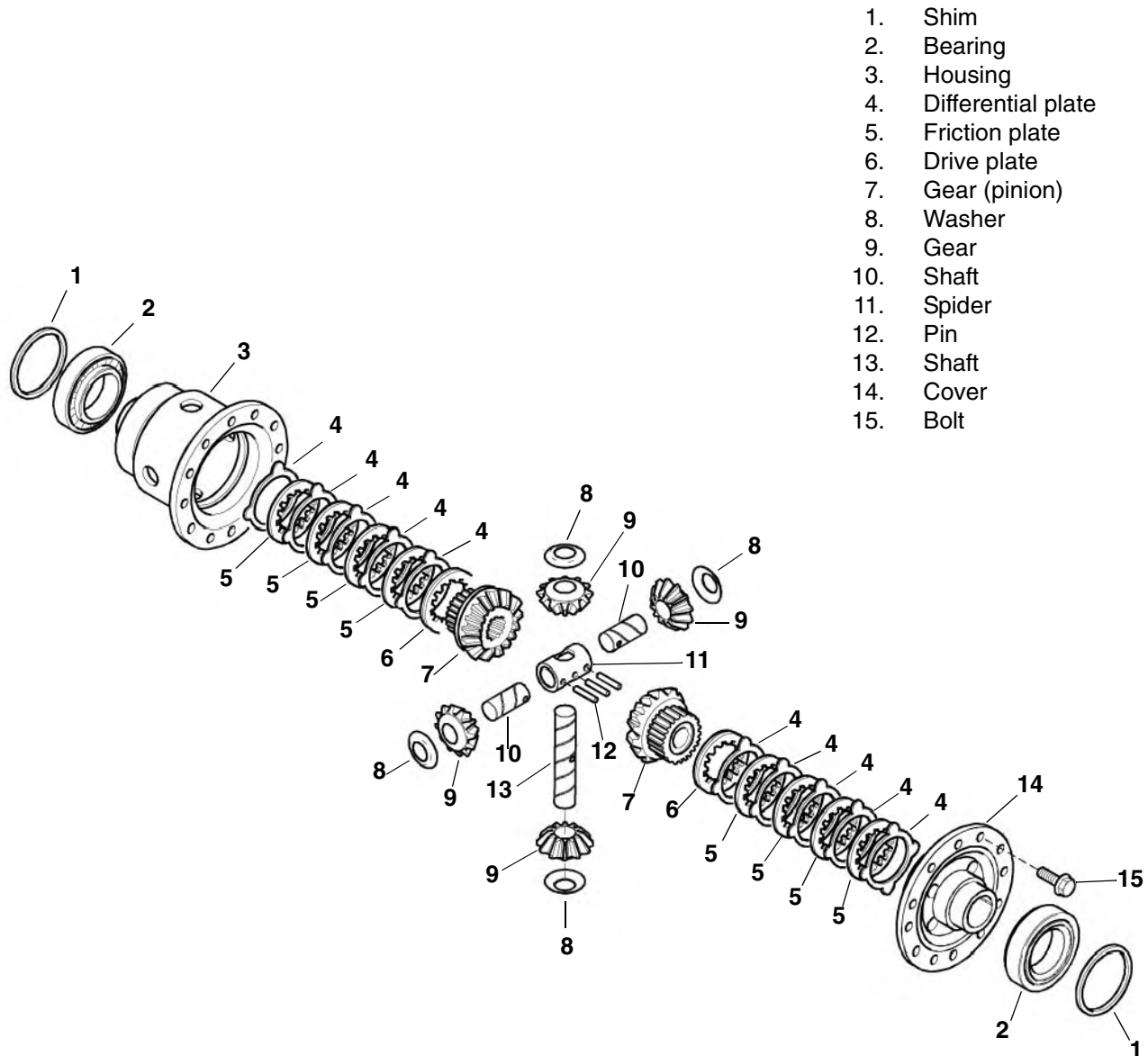

- 1. Shim
- 2. Bearing
- 3. Housing
- 4. Differential plate
- 5. Friction plate
- 6. Drive plate
- 7. Gear (pinion)
- 8. Washer
- 9. Gear
- 10. Shaft
- 11. Spider
- 12. Pin
- 13. Shaft
- 14. Cover
- 15. Bolt

B-23367

## AXLE AND DIFFERENTIAL (FRONT) (CONT'D)

### Pinion Group Disassembly (Cont'd)

Figure 40-41-68

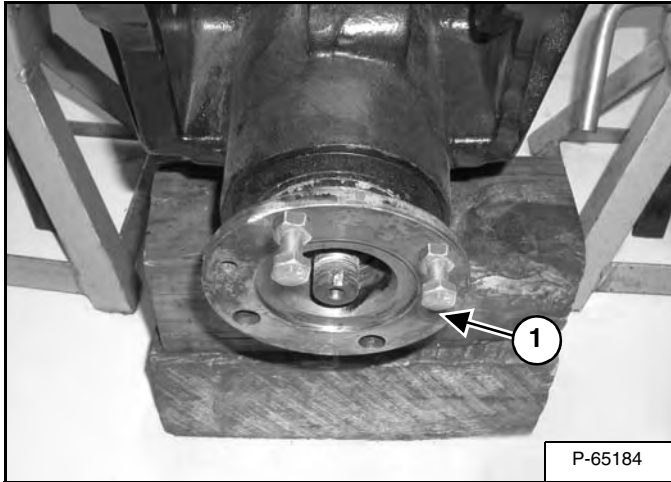

Remove the drive flange (Item 1) [Figure 40-41-68].

Figure 40-41-69

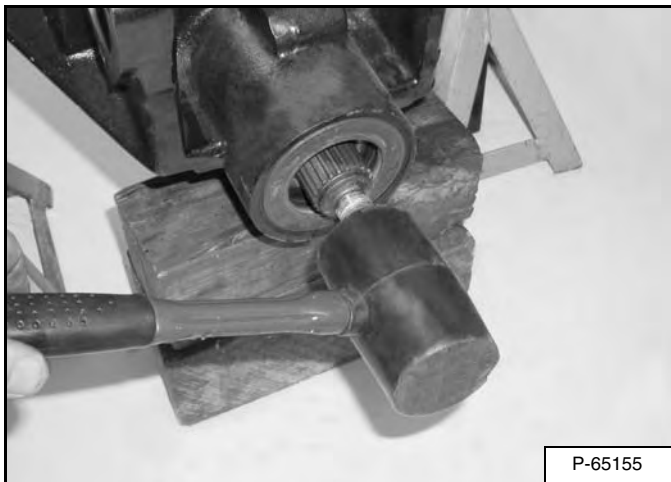

Support the back of the pinion shaft and remove from the housing using a soft hammer [Figure 40-41-69].

Figure 40-41-70

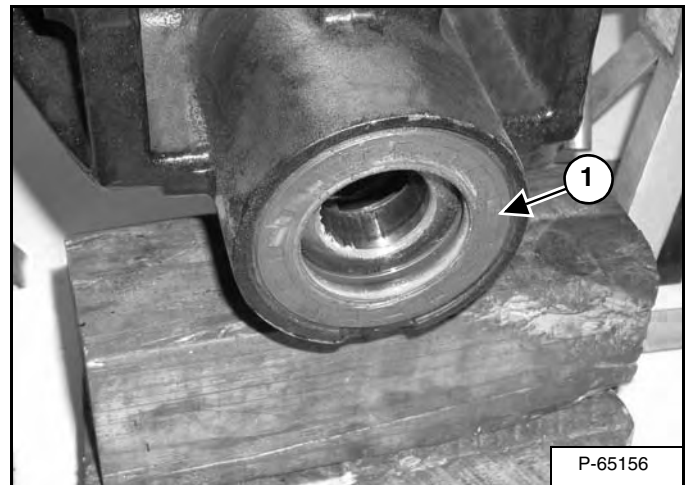

Remove and discard the seal (Item 1) [Figure 40-41-70].

Figure 40-41-71

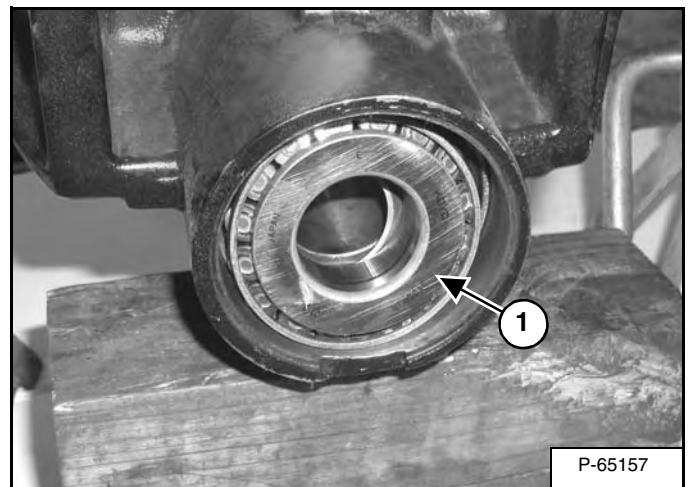

Remove the bearing (Item 1) [Figure 40-41-71].

## AXLE AND DIFFERENTIAL (FRONT) (CONT'D)

### Differential Assembly

Figure 40-41-103

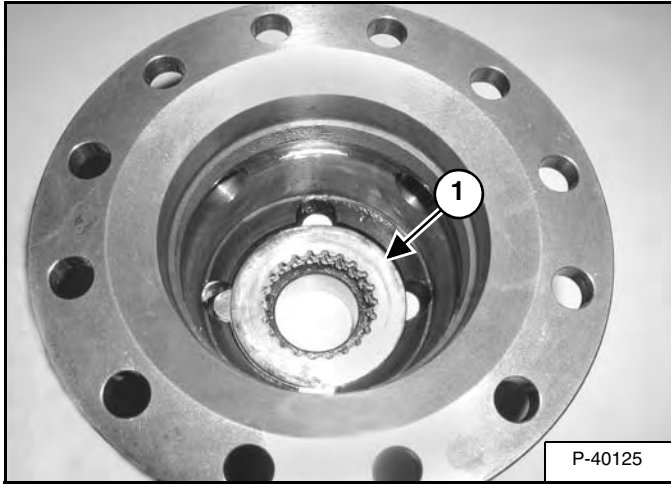

Install the plates (Item 1) [Figure 40-41-103] into the housing, beginning with a steel drive plate and alternating between steel and friction.

**NOTE: The thick washer must be on top (next to gear).**

Figure 40-41-104

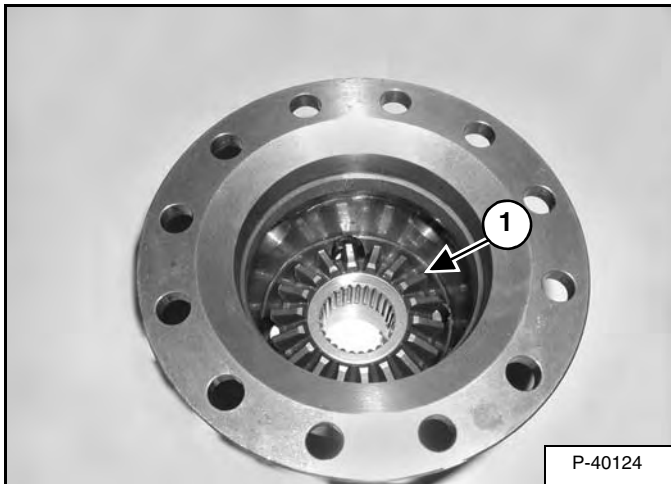

Install the pinion gear (Item 1) [Figure 40-41-104] onto the plate assembly.

**NOTE: Make sure the plates remain in the correct position.**

Figure 40-41-105

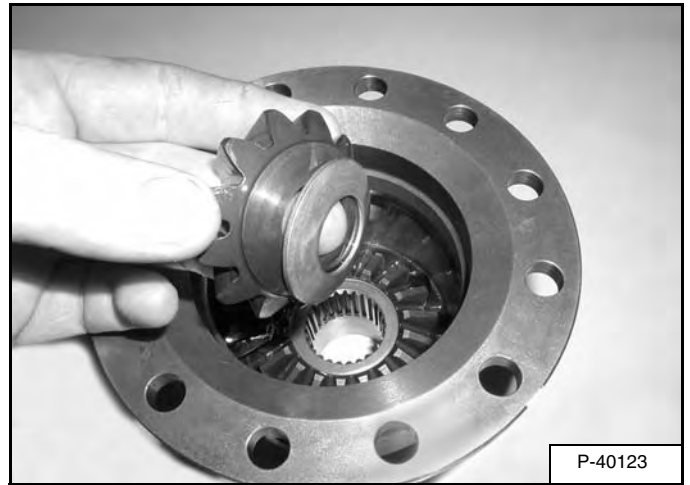

Install the side gear/thrust washer (both sides)[Figure 40-41-105].

Figure 40-41-106

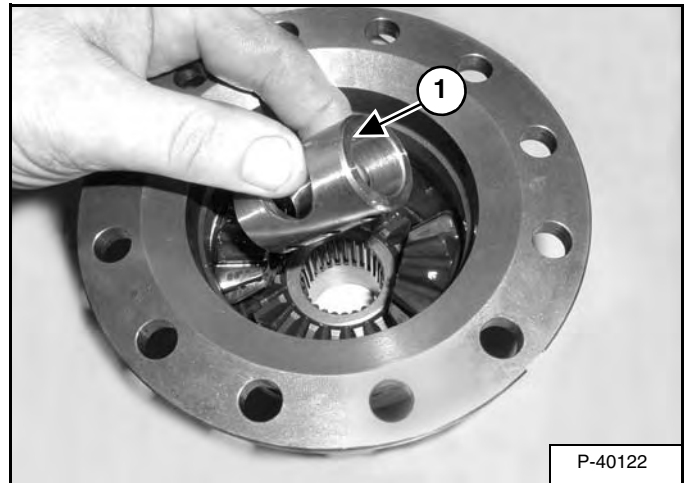

Install the spider shaft (Item 1) [Figure 40-41-106] between the side gears.

**AXLE AND DIFFERENTIAL (FRONT) (CONT'D)**

**Steering Knuckle Assembly (Cont'd)**

**Figure 40-41-138**

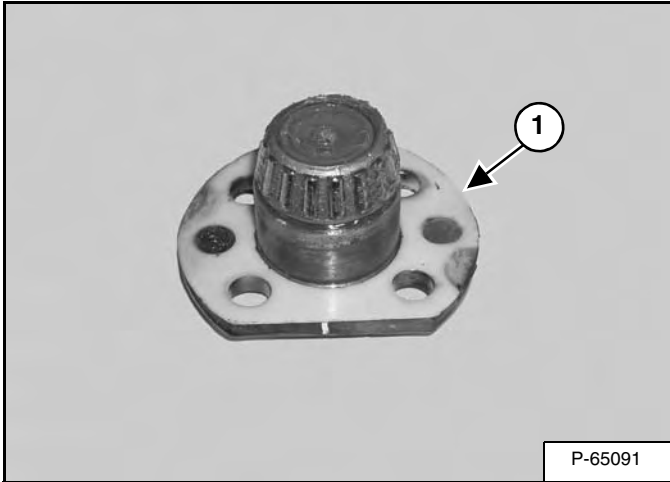

Install the shims (Item 1) [Figure 40-41-138] removed earlier, onto the lower king pin.

**Figure 40-41-139**

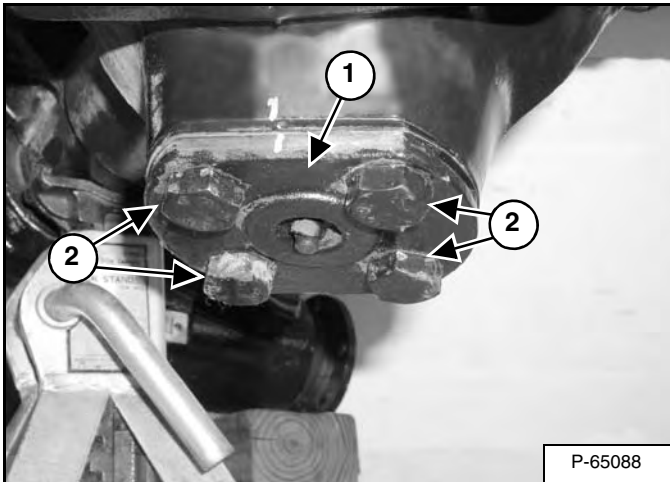

Install the lower king pin (Item 1) using the 4 bolts (Item 2) [Figure 40-41-139]. Do not tighten the bolts at this time.

**Figure 40-41-140**

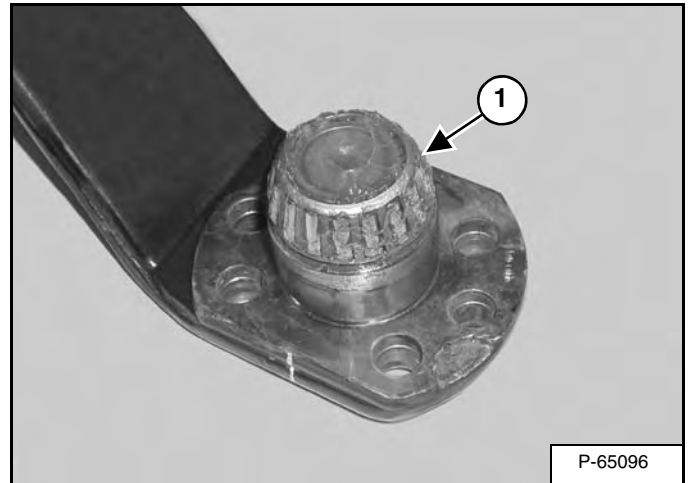

Lubricate and install the bearing (Item 1) [Figure 40-41-140] onto the upper king pin/arm.

**Figure 40-41-141**

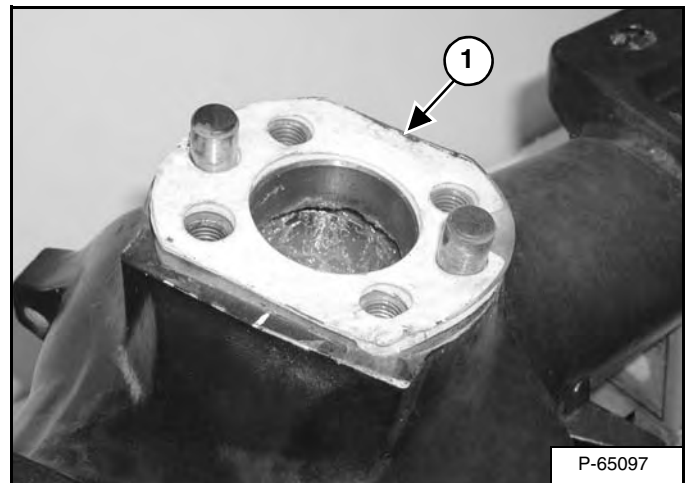

Install the shims (Item 1) [Figure 40-41-141].

## STEERING ANGLE ADJUSTMENT (FRONT AXLE)

### Adjustment

The axle is removed from the machine for photo clarity, but this procedure may be completed with the axle installed in the machine.

Figure 40-42-1

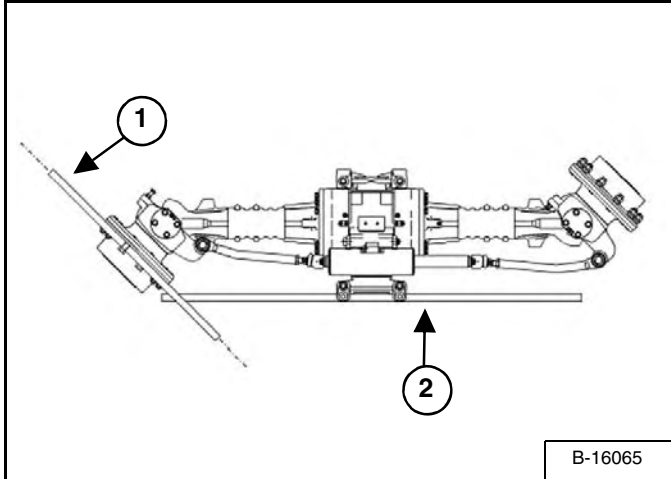

Install the identical, straight bars (Item 1) onto the wheel hub and secure them using lug nuts. Turn the steering wheel completely to one side. Place a straight bar (Item 2) [Figure 40-42-1] on the pinion shaft.

Figure 40-42-2

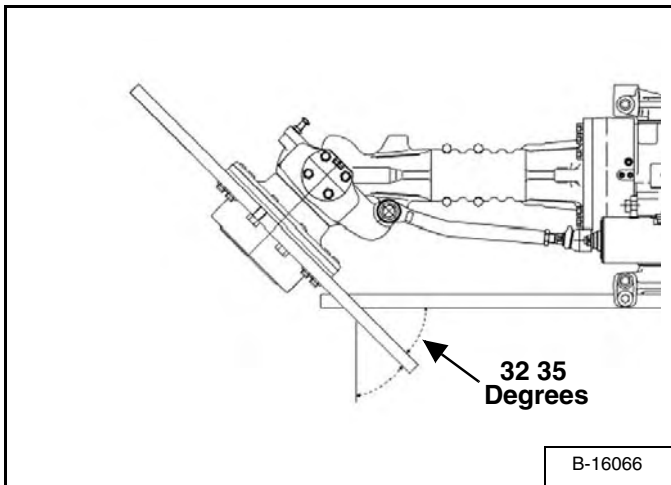

Using an angle gauge, adjust the bolt (Item 1) [Figure 40-42-3] to obtain a reading of between 32 to 35 degrees [Figure 40-42-2].

Figure 40-42-3

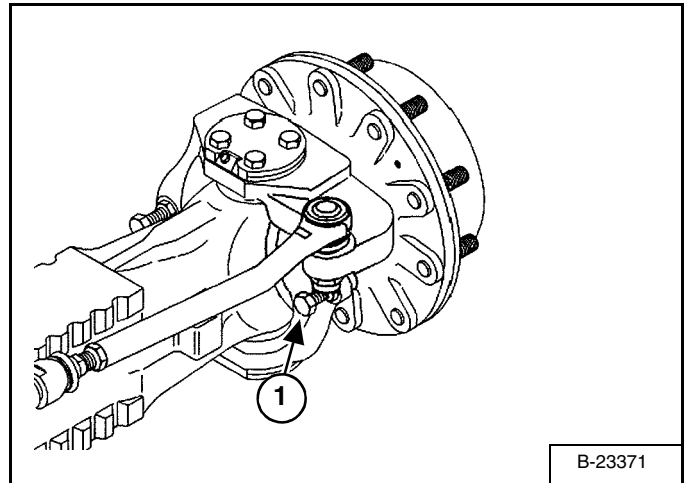

Adjust the stop (Item 1) [Figure 40-42-3] as needed. Tighten the lock nut to 110 ft.-lb. (50 N•m) torque.

Figure 40-42-4

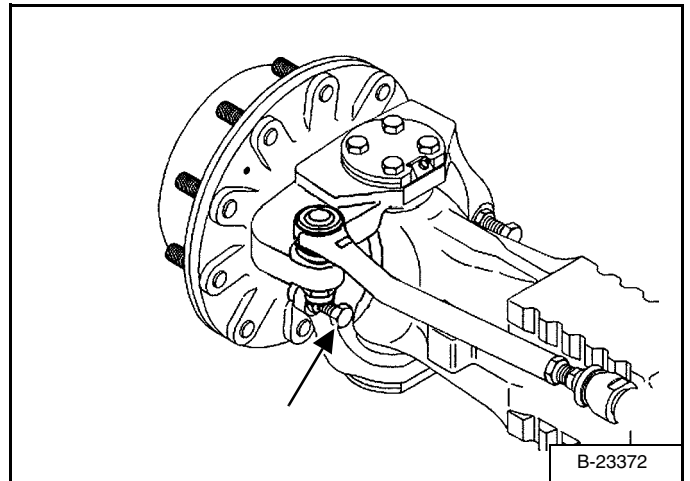

Turn the steering wheel completely to the other side [Figure 40-42-4] and repeat above procedure.

## DROP BOX (CONT'D)

### Disassembly (Cont'd)

Figure 40-60-21

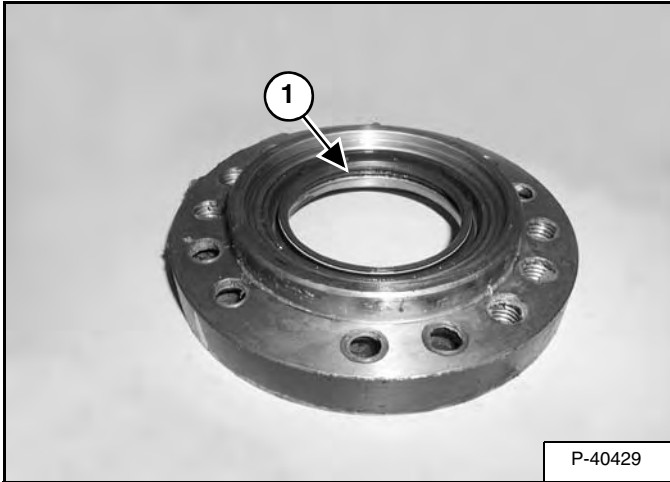

Remove the seal (Item 1) [Figure 40-60-21]. Replace as necessary.

Figure 40-60-22

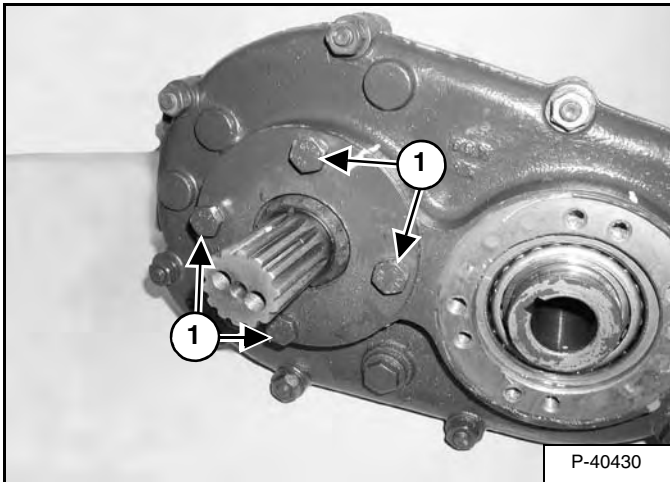

Remove the 4 bolts (Item 1) [Figure 40-60-22] from the bearing flange.

Figure 40-60-23

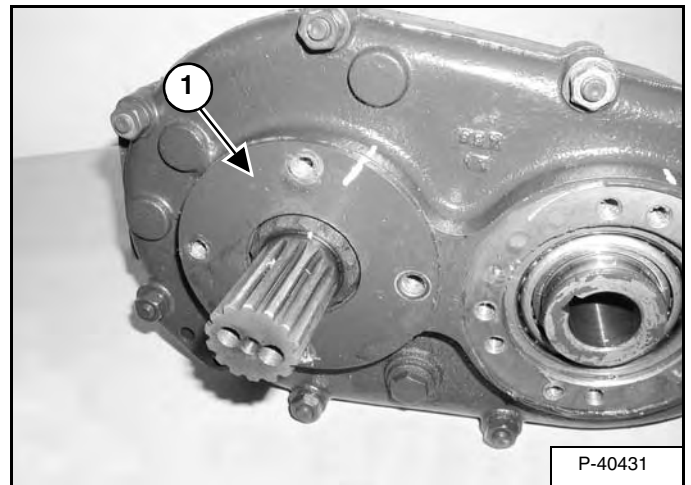

Remove the output bearing flange (Item 1) [Figure 40-60-23].

Figure 40-60-24

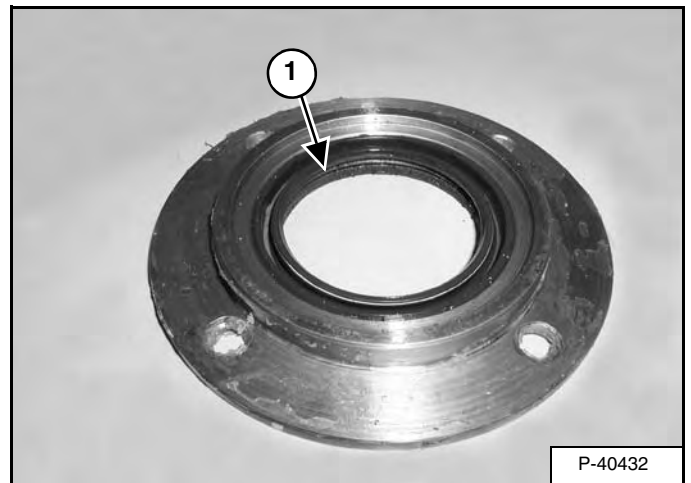

Remove the seal (Item 1) [Figure 40-60-24]. Replace as necessary.

## MAIN FRAME

ARM .....	50-120-1
Arm Pivot Bushing Removal And Installation .....	50-120-3
Removal And Installation .....	50-120-1
BOB-TACH .....	50-110-1
Bob-Tach Lever And Wedge .....	50-110-3
Pivot Pin Bushing Removal And Installation .....	50-110-5
Removal And Installation .....	50-110-1
BOOM .....	50-130-1
Boom Pivot Bushing Removal And Installation .....	50-130-2
Removal And Installation .....	50-130-1
BUCKET .....	50-160-1
Backhoe Bucket Teeth Removal And Installation .....	50-160-1
Loader Bucket Teeth Removal And Installation .....	50-160-1
CAB DOOR .....	50-200-1
Removal And Installation .....	50-200-1
ENCLOSED CAB .....	50-11-1
Cab Mount Removal And Installation .....	50-11-9
Removal And Installation .....	50-11-1
ENGINE COVER .....	50-80-1
Removal And Installation .....	50-80-1
ENGINE SIDE COVERS .....	50-60-1
Removal And Installation .....	50-60-1
FENDER .....	50-70-1
Removal And Installation .....	50-70-1
FLOOR PANELS .....	50-30-1
Left Front Panel Removal And Installation .....	50-30-1
Rear Panel Removal And Installation .....	50-30-2
Right Front Panel Removal And Installation .....	50-30-1
FRONT AXLE PIVOT FRAME .....	50-180-1
Bushing Removal And Installation .....	50-180-3
Installation .....	50-180-2
Removal .....	50-180-1

**MAIN FRAME**

**Continued On Next Page**

## OPERATOR CAB (CONT'D)

### Cab Mount Removal And Installation

Figure 50-10-32

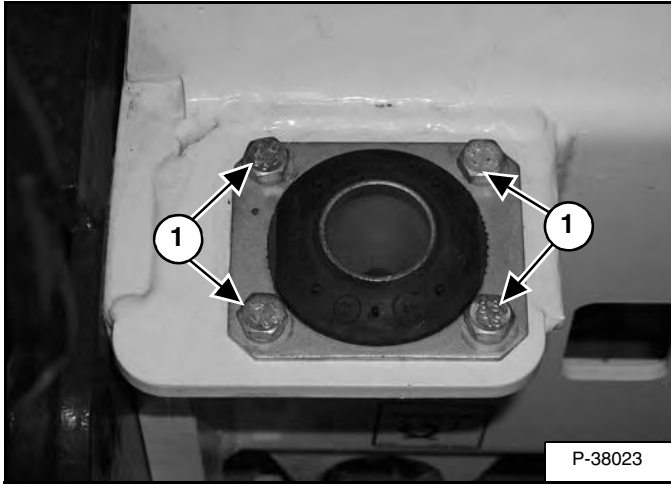

With the cab removed, remove the 4 mounting bolts (Item 1) [Figure 50-10-32].

**Installation:** Tighten bolts to 32 to 35 ft.-lb. (43 to 47 N•m) torque.

Figure 50-10-33

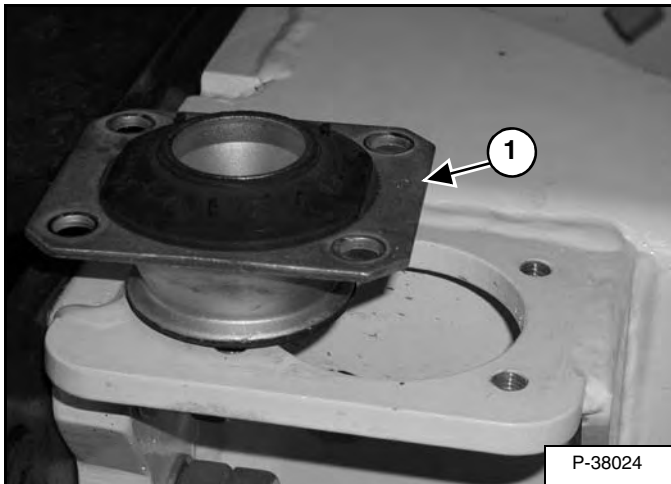

Remove the mount (Item 1) [Figure 50-10-33].

Replace as needed.

## Cab Mount Removal And Installation

Figure 50-11-31

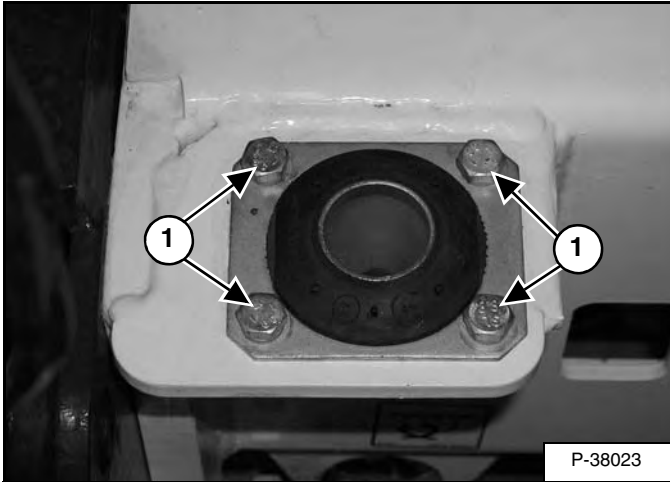

With the cab removed, remove the 4 mounting bolts (Item 1) [Figure 50-11-31].

**Installation:** Tighten bolts to 32 to 35 ft.-lb. (43 to 47 N•m) torque.

Figure 50-11-32

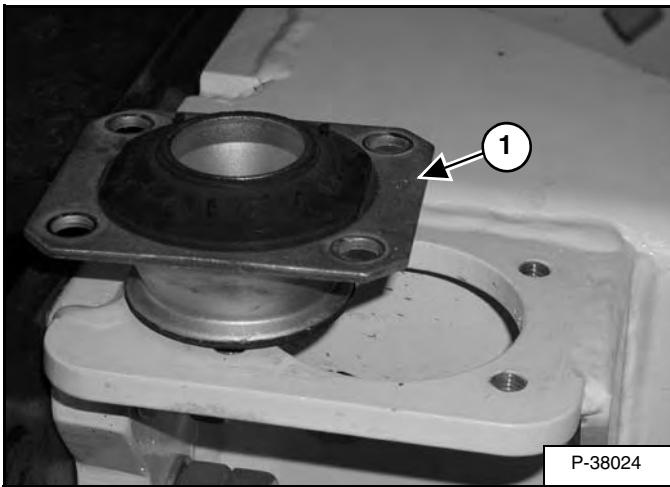

Remove the mount (Item 1) [Figure 50-11-32].

Replace as needed.

## ENGINE SIDE COVERS

### Removal And Installation

Raise the lift arms and install an approved lift arm support device. (See Installing The Approved Lift Arm Support Device on Page 10-20-1.)

Figure 50-60-1

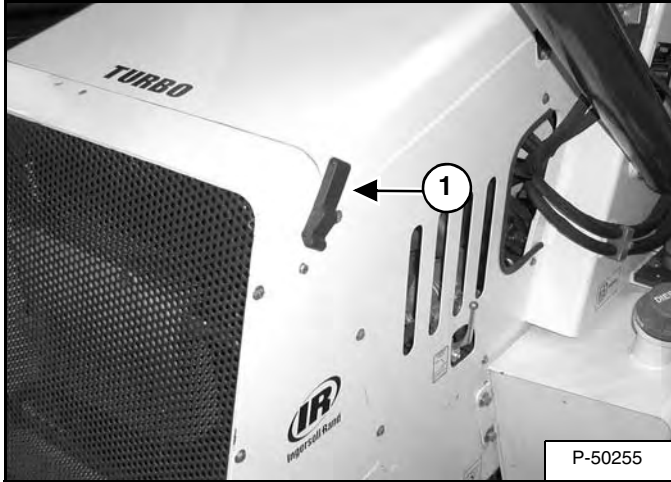

Release both engine cover latches (Item 1) [Figure 50-60-1].

Figure 50-60-2

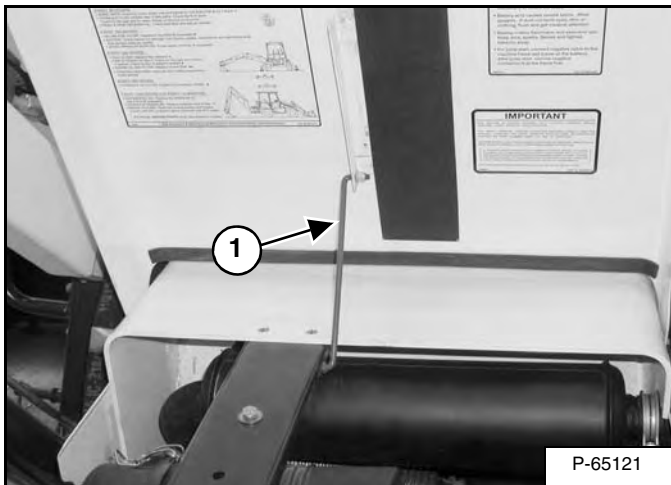

Raise the engine cover until the support rod (Item 1) [Figure 50-60-2] is in the lock position.

Figure 50-60-3

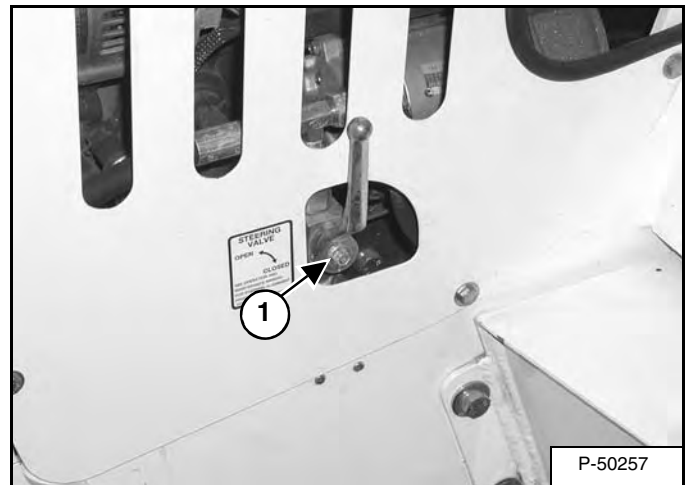

Remove the bolt (Item 1) [Figure 50-60-3] from the steering valve handle.

Remove the handle.

Figure 50-60-4

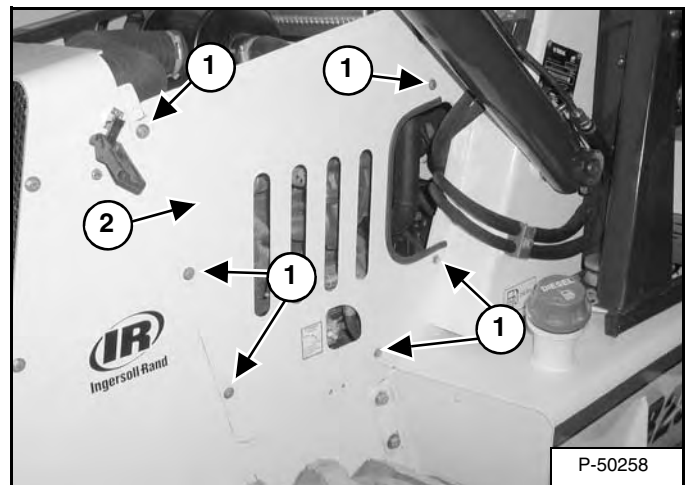

Remove the 6 side cover mounting bolts (Item 1) and remove the side cover (Item 2) [Figure 50-60-4].

**Installation:** Tighten the bolts to 4 to 5 ft.-lb. (5,5 to 6,5 N•m) torque.

## LIFT ARMS (CONT'D)

### Removal And Installation (Cont'd)

Figure 50-100-7

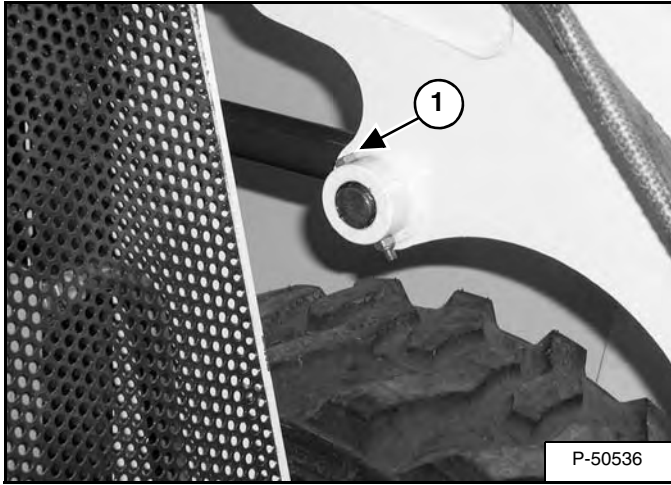

Remove the pivot pin retainer bolt (Item 1) [Figure 50-100-7] from the rod end of the lift cylinder (both sides).

**Installation:** Tighten the bolt to 32 to 35 ft.-lb. (43 to 47 N•m) torque.

Figure 50-100-8

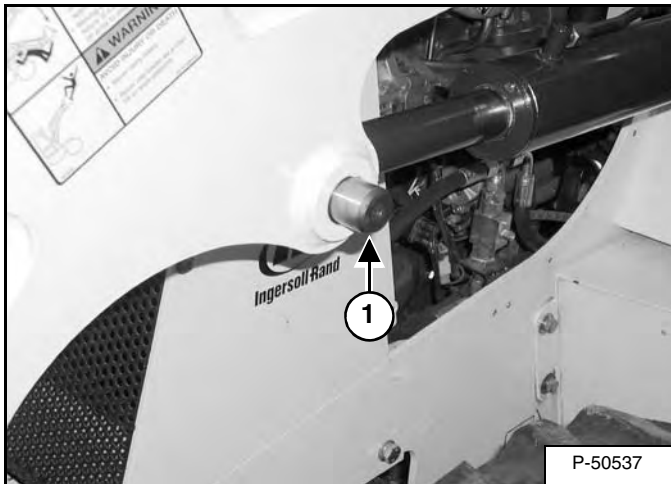

Remove the lift cylinder pivot pin (Item 1) [Figure 50-100-8] and lower the cylinders (both sides).

Figure 50-100-9

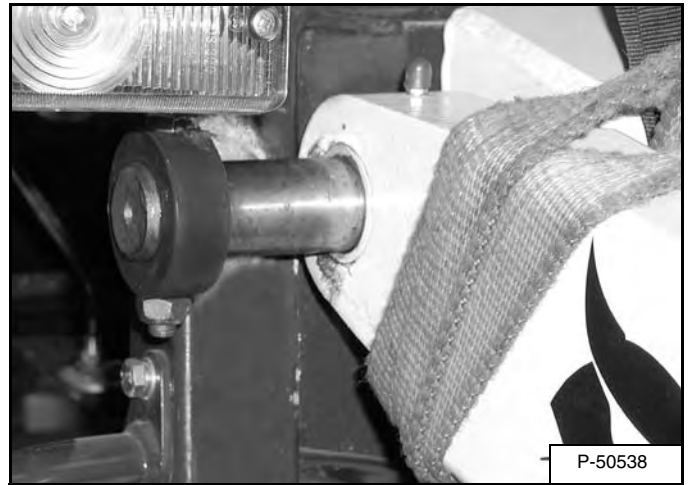

Remove the lift arm pivot pin [Figure 50-100-9] (both sides).

Figure 50-100-10



Lift and remove the loader lift arm assembly [Figure 50-100-10].

## ARM (CONT'D)

### Removal And Installation (Cont'd)

Figure 50-120-9



Remove the arm (Item 1) [Figure 50-120-9].

## Arm Pivot Bushing Removal And Installation

Figure 50-120-10

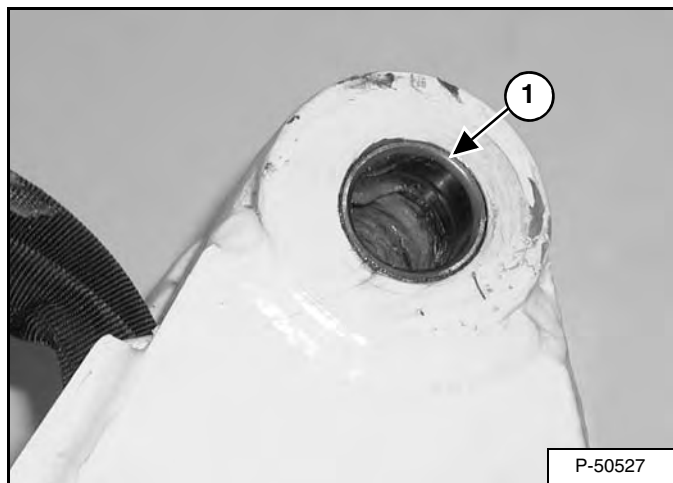

Remove the bushing (Item 1) [Figure 50-120-10] (both sides).

**Installation:** Fully seat the bushings in the arm.

## BUCKET

### Backhoe Bucket Teeth Removal And Installation

Figure 50-160-1

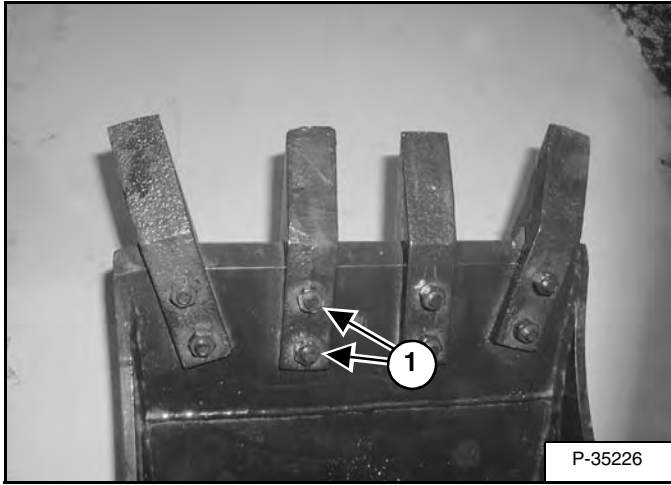

Remove the 2 bolts (Item 1) [Figure 50-160-1], nuts and washers.

**Installation:** Tighten the bolts to 55 to 60 ft.-lb. (75 to 85 N•m) torque.

Figure 50-160-2

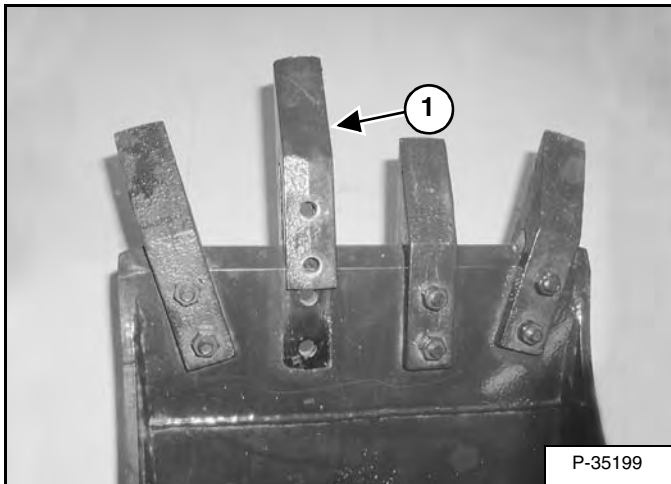

Remove the bucket teeth (Item 1) [Figure 50-160-2].

### Loader Bucket Teeth Removal And Installation

Figure 50-160-3

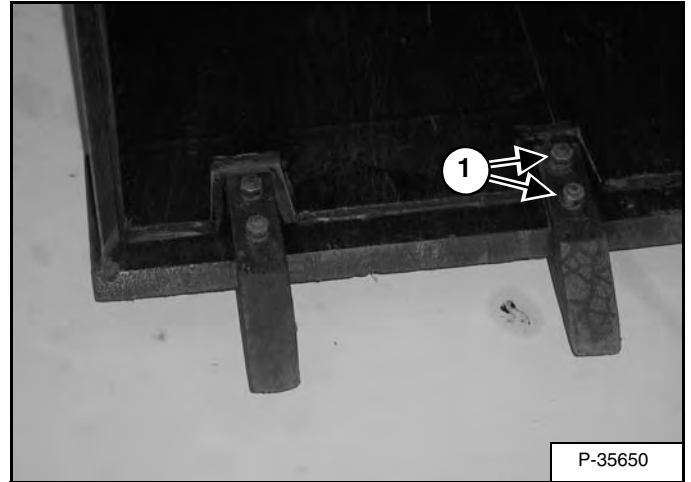

Remove the 2 bolts (Item 1) [Figure 50-160-3], nuts and washers.

**Installation:** Tighten the bolts to 55 to 60 ft.-lb. (75 to 85 N•m) torque.

Figure 50-160-4

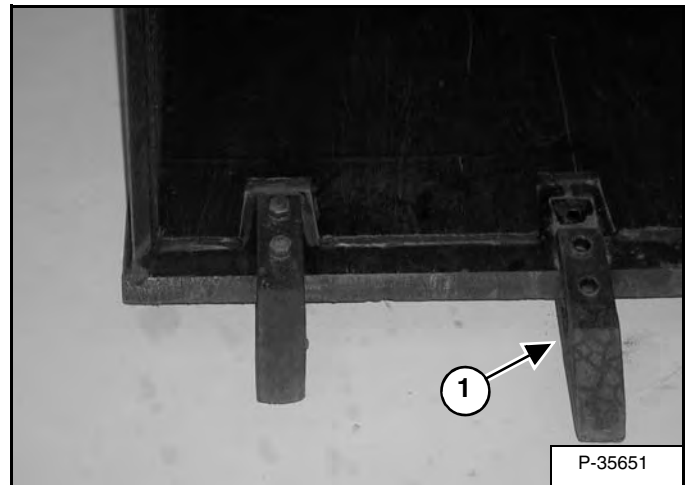

Remove the bucket teeth (Item 1) [Figure 50-160-4].

## REAR WINDOW

### Removal And Installation

Stop the engine, engage parking brake.

Figure 50-190-1

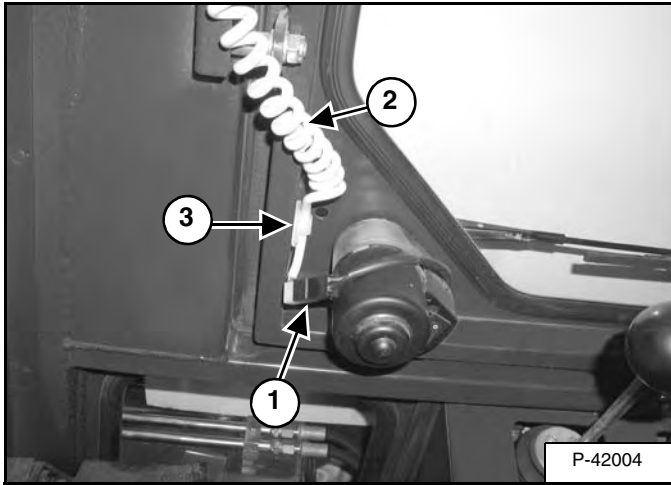

Disconnect the harness connector (Item 1) and remove the harness (Item 2) from the mounting tab (Item 3) [Figure 50-190-1].

Figure 50-190-2

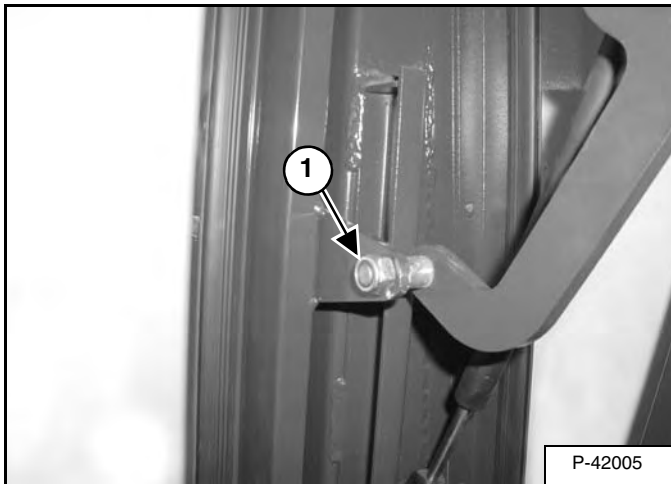

Remove the nut (Item 1) [Figure 50-190-2].

**Installation:** Tighten nut to 18 to 19 ft.-lb. (24 to 26 N•m) torque.

Figure 50-190-3

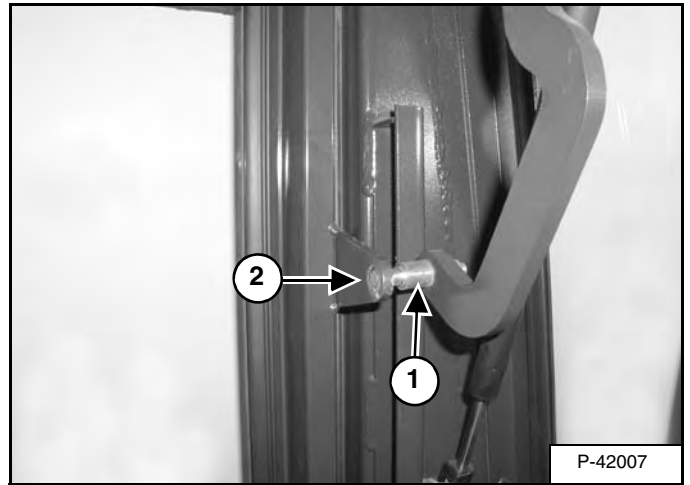

Remove the pivot assembly (Item 1) from the window frame (Item 2) [Figure 50-190-3].

**NOTE:** The pivot assembly is under tension.

Figure 50-190-4

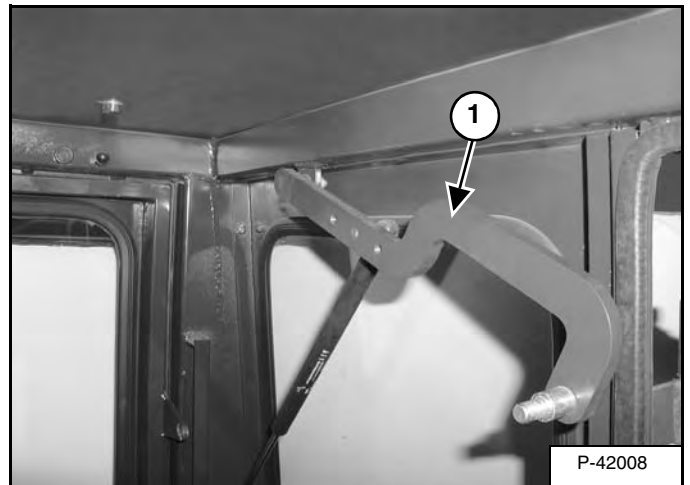

Rotate the pivot assembly (Item 1) [Figure 50-190-4] away from the window frame.

## ELECTRICAL SYSTEM INFORMATION

### Troubleshooting Chart

The following troubleshooting chart is provided for assistance in locating and correcting problems which are most common. Many of the recommended procedures must be done by authorized Bobcat Service Personnel only.



**Instructions are necessary before operating or servicing machine. Read and understand the Operation & Maintenance Manual, Handbook and signs (decals) on machine. Follow warnings and instructions in the manuals when making repairs, adjustments or servicing. Check for correct function after adjustments, repairs or service. Untrained operators and failure to follow instructions can cause injury or death.**

W-2003-0199

PROBLEM	SOLUTION#
Battery will not take charge.	1, 2, 3, 4, 5
Alternator will not charge.	1, 2, 5
Starter will not turn the engine.	2, 3, 4, 6, 7, 8, 9

#### KEY TO CORRECT THE CAUSE

1. Alternator belt is loose or damaged.
2. Battery connections are dirty or loose.
3. Battery is damaged.
4. The ground connection is not making a good contact.
5. The alternator is damaged.
6. The engine is locked.
7. The starter is damaged.
8. The wiring or the solenoid is damaged.
9. Check the fuses.

## ALTERNATOR (CONT'D)

### Removal And Installation

Raise the lift arms and install the approved lift arm support device. (See Installing The Approved Lift Arm Support Device on Page 10-20-1.)

Stop the engine, engage the parking brake.

Open the engine cover. (See ENGINE COVER on Page 10-30-1.)

Remove the cover from the left side of the engine. (See Removal And Installation on Page 50-60-1.)

Rotate the battery disconnect lever counterclockwise to disconnect battery from system.

**Figure 60-30-9**

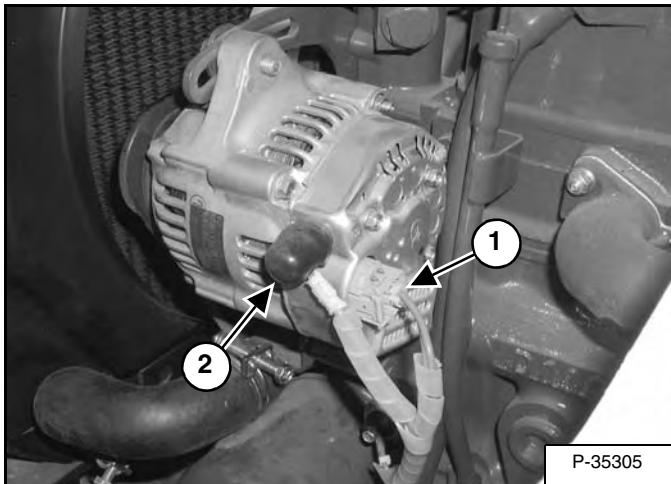

Disconnect the wiring harness (Item 1) [Figure 60-30-9] from the alternator.

Remove the red wire (Item 2) [Figure 60-30-9].

**Figure 60-30-10**

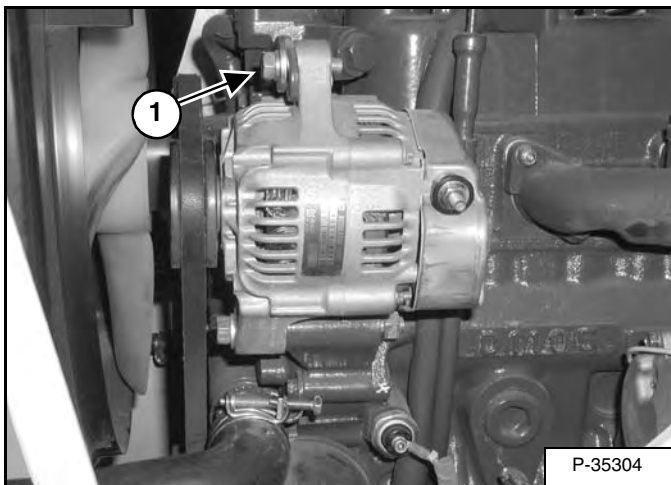

Loosen the alternator adjusting bolt (Item 1) [Figure 60-30-10].

Remove the alternator belt from the alternator.

**Figure 60-30-11**

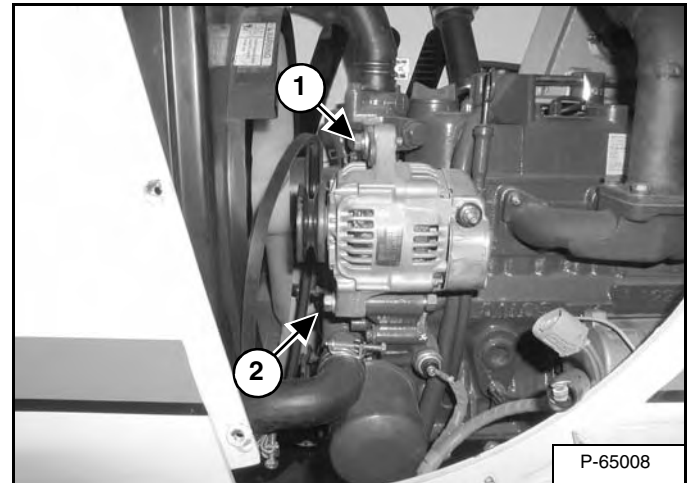

Remove the adjusting bolt (Item 1) and mounting bolt and nut (Item 2) [Figure 60-30-11].

Remove the alternator.

# STARTER (CONT'D)

## Parts Identification

- 1. Bearing
- 2. Armature
- 3. Bearing
- 4. Frame
- 5. Brush Spring
- 6. Brush Holder
- 7. Cover
- 8. Bolt
- 9. Bolt
- 10. Bolt
- 11. Cover

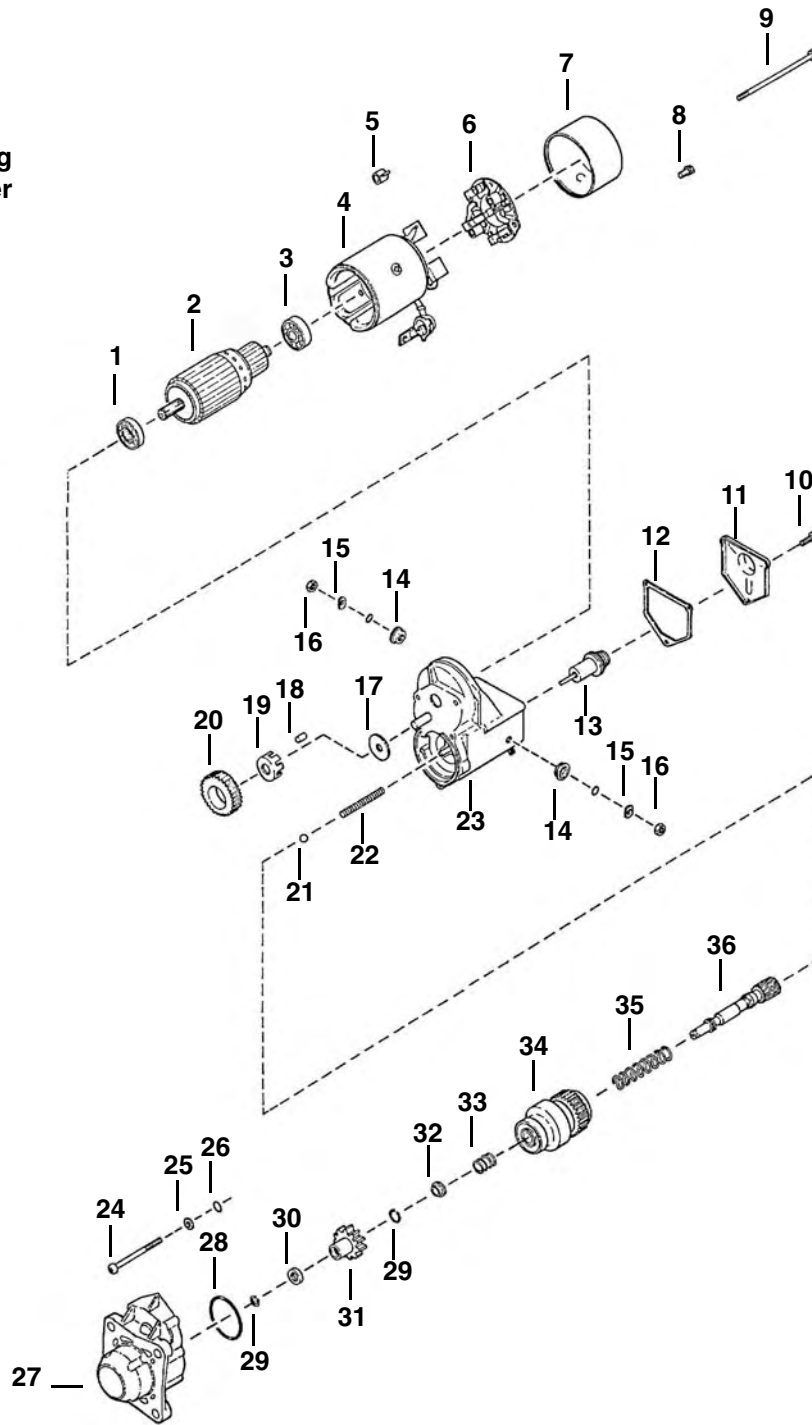

- 12. Gasket
- 13. Switch
- 14. Nut
- 15. Washer
- 16. Nut
- 17. Washer
- 18. Roller
- 19. Retainer
- 20. Idler Gear
- 21. Ball
- 22. Spring

- 23. Housing
- 24. Screw
- 25. Washer
- 26. O-ring
- 27. Housing
- 28. O-ring
- 29. Snap Ring
- 30. Collar
- 31. Pinion Gear
- 32. Spring seat
- 33. Spring
- 34. Clutch
- 35. Spring
- 36. Pinion Shaft

D-2297



## FRONT LIGHTS (CONT'D)

### Housing Removal And Installation

Figure 60-50-7

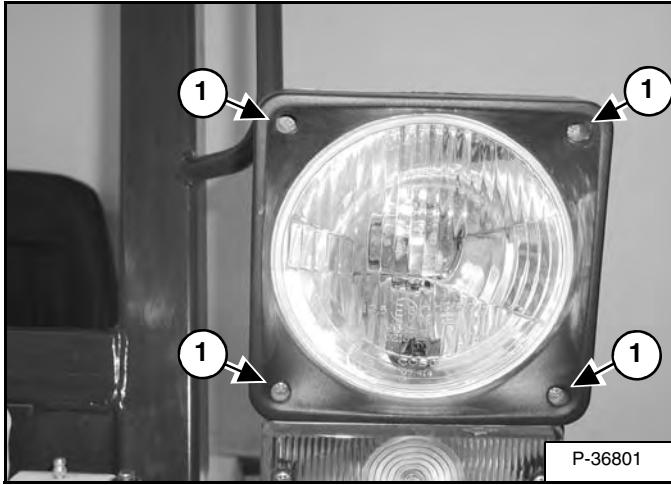

Remove the 4 screws (Item 1) [Figure 60-50-7] while supporting the lamp.

Figure 60-50-8

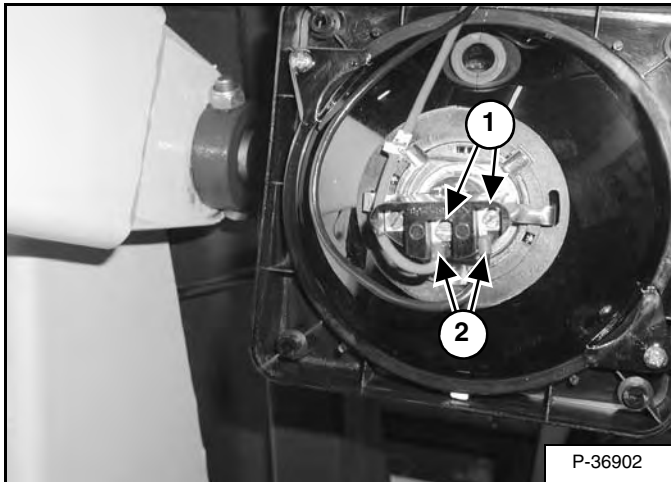

Loosen the 2 screws (Item 1) and remove the wires (Item 2) [Figure 60-50-8].

**NOTE: Mark the wires for correct assembly.**

Remove the front turn indicator light (See TURN INDICATOR LIGHTS (FRONT) on Page 60-51-1.)

Figure 60-50-9

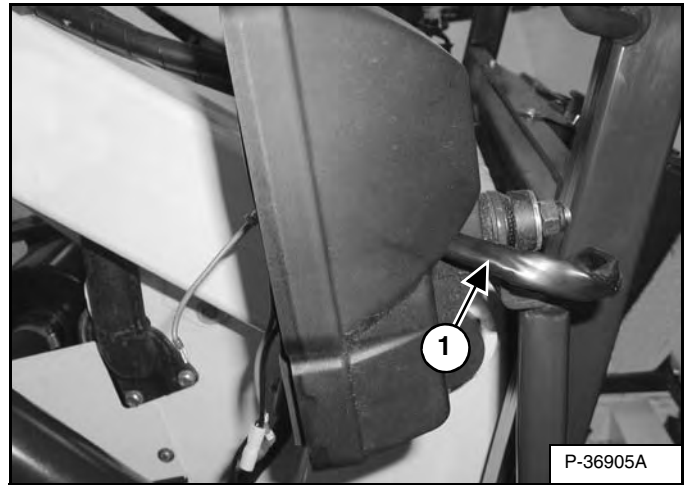

Remove the harness (Item 1) [Figure 60-50-9] from the housing.

Figure 60-50-10

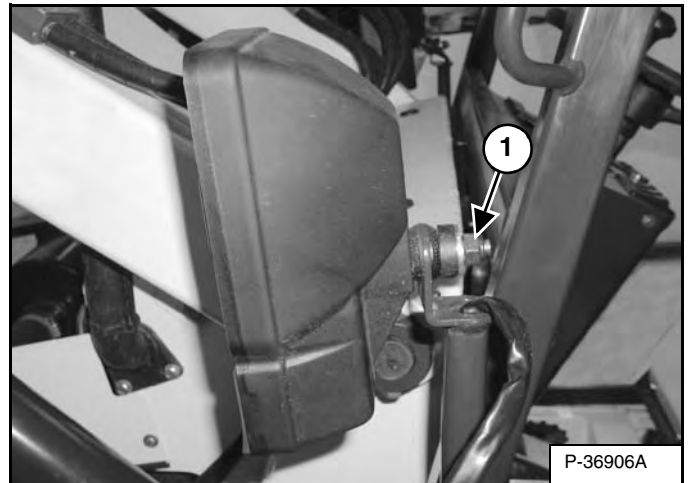

While supporting the housing assembly, remove the mounting nut (Item 1) [Figure 60-50-10].

## FUEL LEVEL SENDER

### Removal And Installation

Remove the front left floor panel. (See Left Front Panel Removal And Installation on Page 50-30-1)

Figure 60-60-1

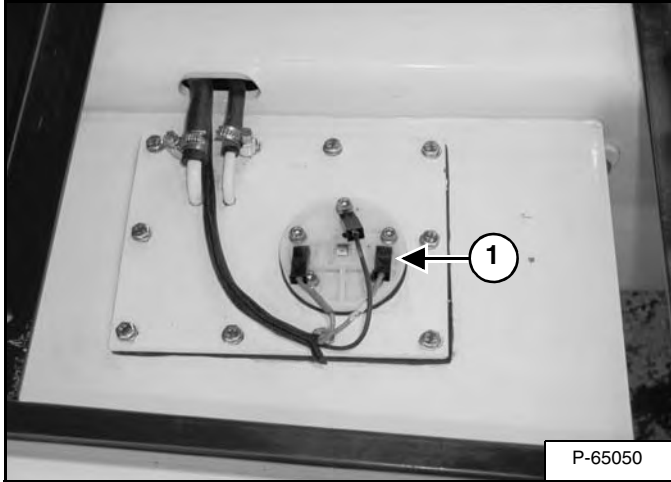

Remove the 3 wires (Item 1) [Figure 60-60-1].

**NOTE:** Mark wires for correct assembly.

Figure 60-60-2

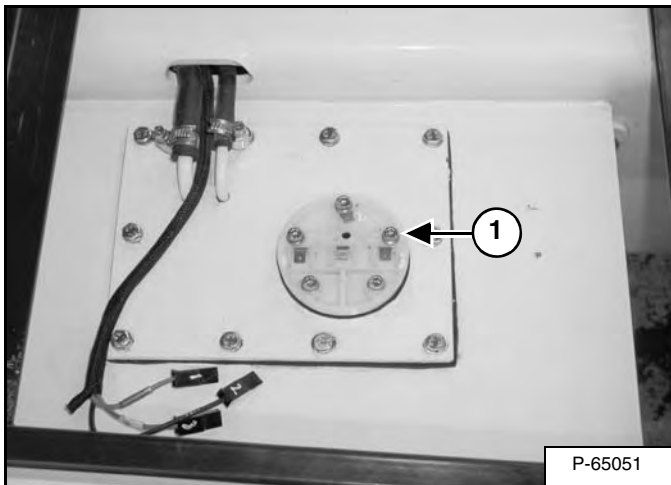

Remove the 5 bolts (Item 1) [Figure 60-60-2] from the fuel level sender.

**Installation:** Tighten bolts to 2 to 2.5 ft.-lb. (2,5 to 3,5 N•m) torque.

Figure 60-60-3

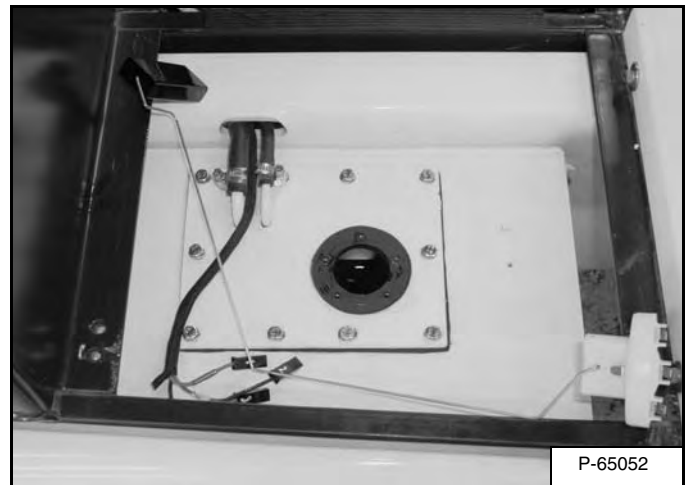

Remove the fuel level sender [Figure 60-60-3].

**NOTE:** Lower float arm to bottom of tank to remove the fuel level sender.

## ENGINE SERVICE

AIR CLEANER . . . . .	70-40-1
Removal And Installation . . . . .	70-40-1
ENGINE . . . . .	70-70-1
Mount Replacement . . . . .	70-70-5
Removal And Installation . . . . .	70-70-1
ENGINE COMPONENTS AND TESTING . . . . .	70-60-1
Checking Engine Compression . . . . .	70-60-1
Checking Fuel Injection Pump . . . . .	70-60-5
Checking Fuel Injector, Nozzles . . . . .	70-60-11
Checking Glow Plugs . . . . .	70-60-2
Fuel Injection Pump Removal And Installation . . . . .	70-60-6
Fuel Injection Pump Timing . . . . .	70-60-8
Fuel Injector Nozzles Removal And Installation . . . . .	70-60-9
Fuel Shut-Off Solenoid Removal And Installation . . . . .	70-60-4
Glow Plug Removal And Installation . . . . .	70-60-3
Thermostat Removal And Installation . . . . .	70-60-12
Water Pump Removal And Installation . . . . .	70-60-13
ENGINE SPEED CONTROL . . . . .	70-20-1
Cable Removal And Installation . . . . .	70-20-2
Removal And Installation . . . . .	70-20-1
FLYWHEEL . . . . .	70-100-1
Removal And Installation . . . . .	70-100-1
Ring Gear Removal And Installation . . . . .	70-100-1
FLYWHEEL HOUSING . . . . .	70-90-1
Removal And Installation . . . . .	70-90-1
MUFFLER . . . . .	70-30-1
Removal And Installation . . . . .	70-30-1
RADIATOR . . . . .	70-50-1
Removal And Installation . . . . .	70-50-1

Continued On Next Page

**ENGINE  
SERVICE**

## AIR CLEANER

### Removal And Installation

Raise the lift arms and install an approved lift arm support device. (See Installing The Approved Lift Arm Support Device on Page 10-20-1.)

Stop the engine.

Open the engine cover. (See ENGINE COVER on Page 10-30-1.)

Remove the engine side cover from the right side. (See Removal And Installation on Page 50-60-1.)

**Figure 70-40-1**

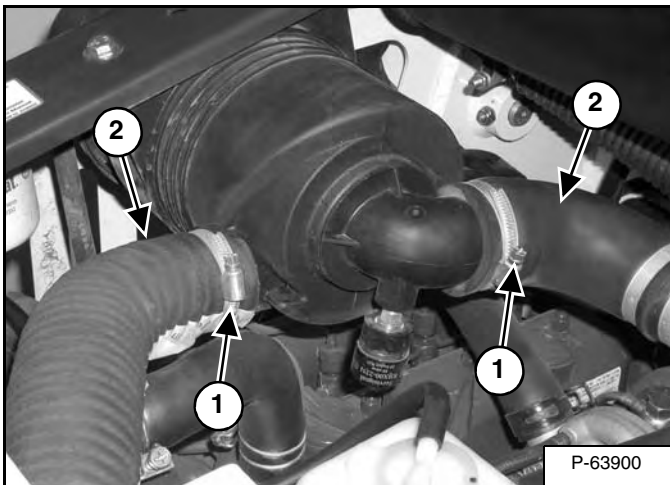

Loosen the hose clamps (Item 1) and remove the hoses (Item 2) [Figure 70-40-1] from the air cleaner housing.

**Figure 70-40-2**

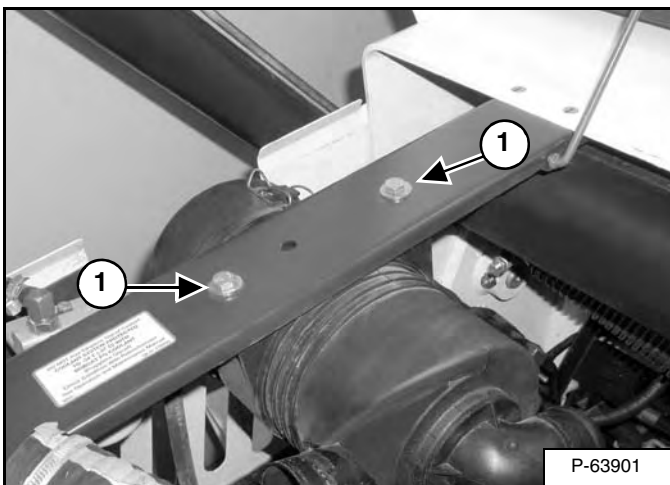

Remove the 2 mounting bolts (Item 1) [Figure 70-40-2].

**Installation:** Tighten the bolts to 18 to 19 ft.-lb. (24 to 26 N•m) torque.

**Figure 70-40-3**



Remove the air cleaner assembly [Figure 70-40-3].

## ENGINE COMPONENTS AND TESTING (CONT'D)

### Fuel Injection Pump Removal And Installation (Cont'd)

Figure 70-60-16

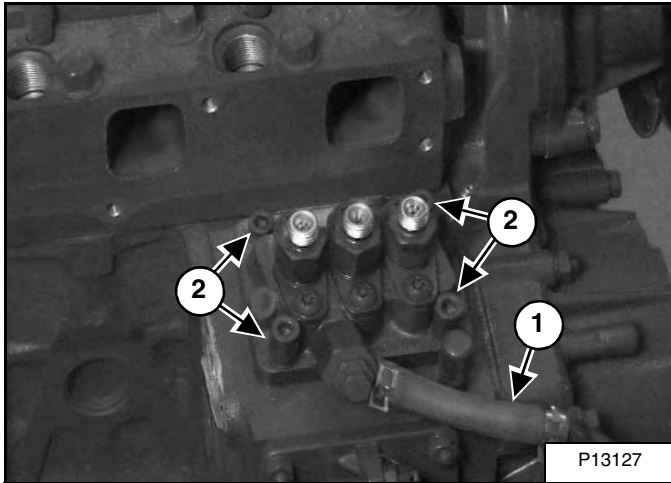

Disconnect the fuel inlet hose (Item 1) [Figure 70-60-16] from the injection pump.

Remove the 4 mounting bolts (Item 2) [Figure 70-60-16] from the top of the injection pump.

**Installation:** Tighten the mounting bolts to 16 to 20 ft.-lb. (22 to 27 N•m) torque.

Figure 70-60-17

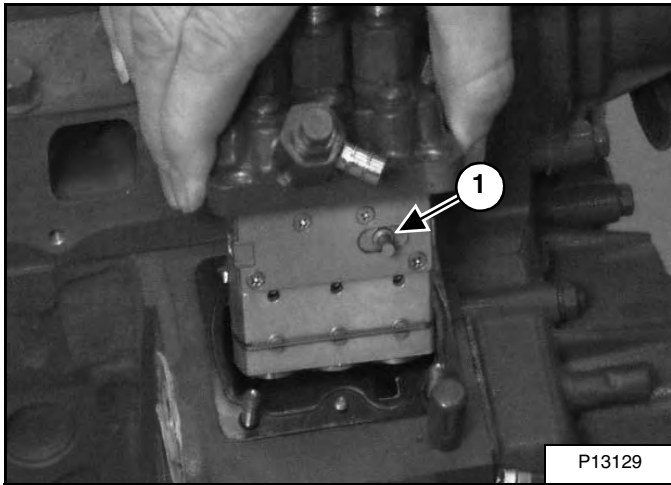

Remove the injection pump from the engine [Figure 70-60-17].

Figure 70-60-18

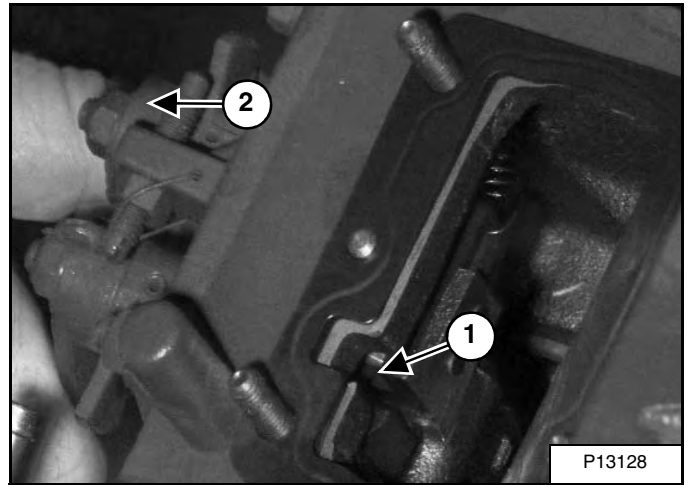

**Installation:** The fuel rack pin (Item 1) [Figure 70-60-17] on the injection pump must be aligned with the notch (Item 1) [Figure 70-60-18] located inside the injection pump chamber. Use the throttle lever (Item 2) [Figure 70-60-18] on the side of the injection pump chamber to align the notch.

Figure 70-60-19

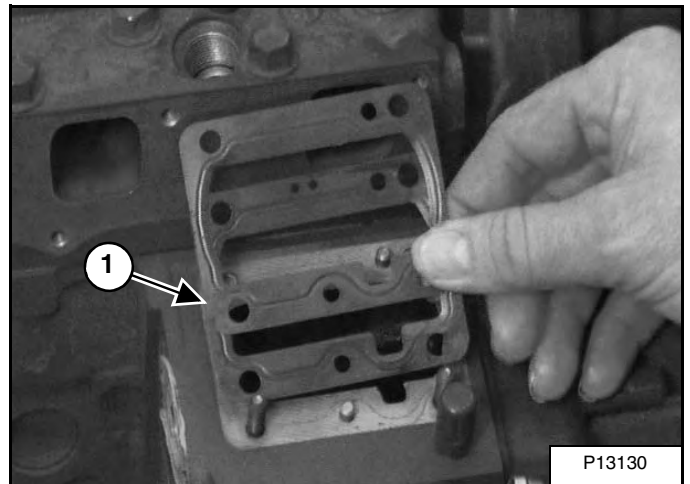

Install the shim(s) (Item 1) [Figure 70-60-19] on the injection pump mounting surface. (See Fuel Injection Pump Timing on Page 70-60-8 for information on number of shims used.)

Install the injection pump in the engine.

## ENGINE (CONT'D)

### Removal And Installation (Cont'd)

Figure 70-70-9

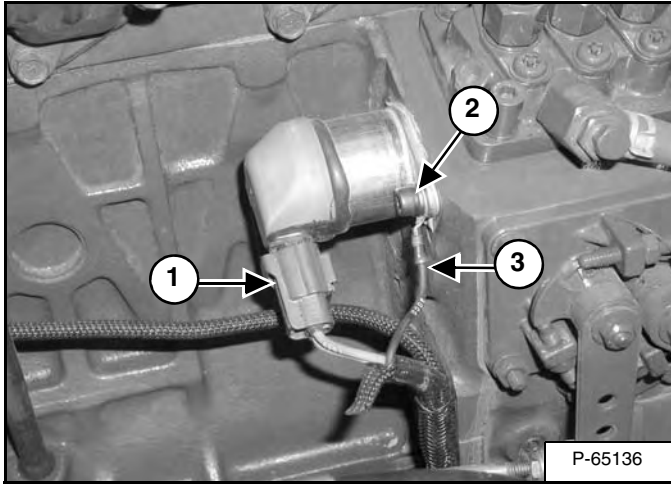

Remove the harness connector (Item 1), bolt (Item 2) and wire (Item 3) [Figure 70-70-9] from the fuel shutoff solenoid.

Figure 70-70-10

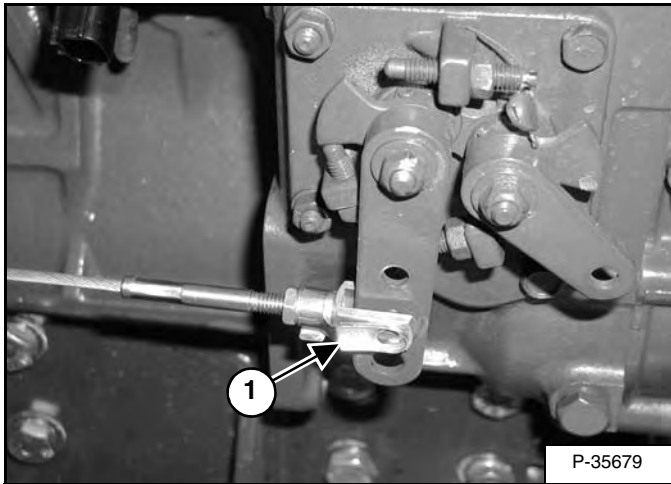

Remove the engine speed control cable (Item 1) [Figure 70-70-10].

Figure 70-70-11

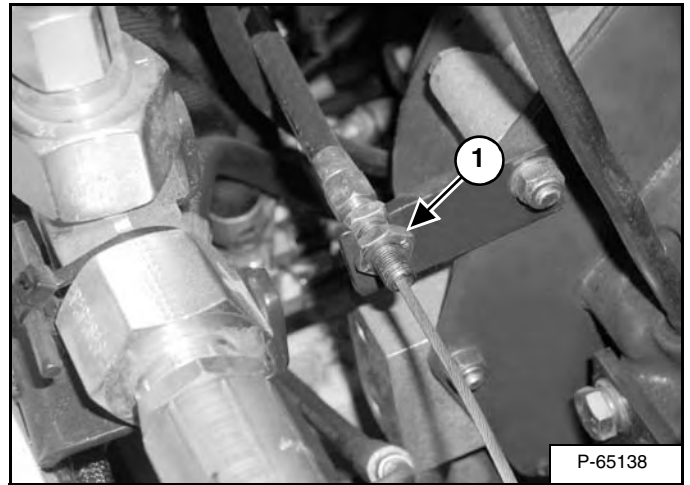

Loosen the jam nut (Item 1) [Figure 70-70-11] and remove the engine speed control cable.

**NOTE:** Mark the location of the jam nut for correct assembly.

Figure 70-70-12

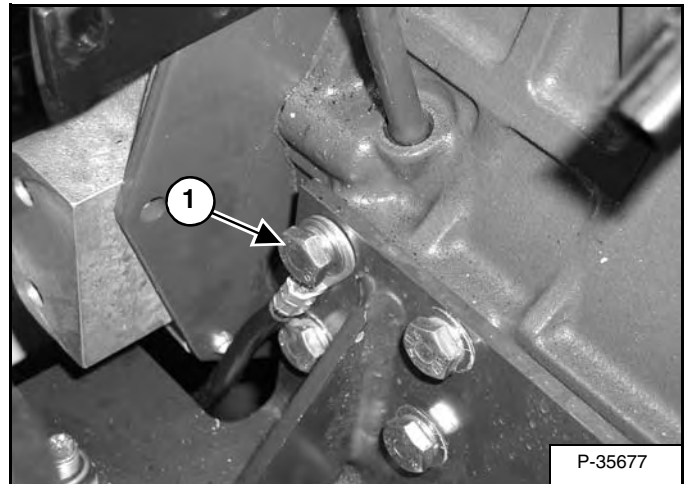

Remove the bolt (Item 1) [Figure 70-70-12] and remove the ground strap.

Remove the front left floor panel. (See FLOOR PANELS on Page 50-30-1.)

## RECONDITIONING THE ENGINE (CONT'D)

### Idle Limit And Fuel Limit Adjustment

Figure 70-80-25

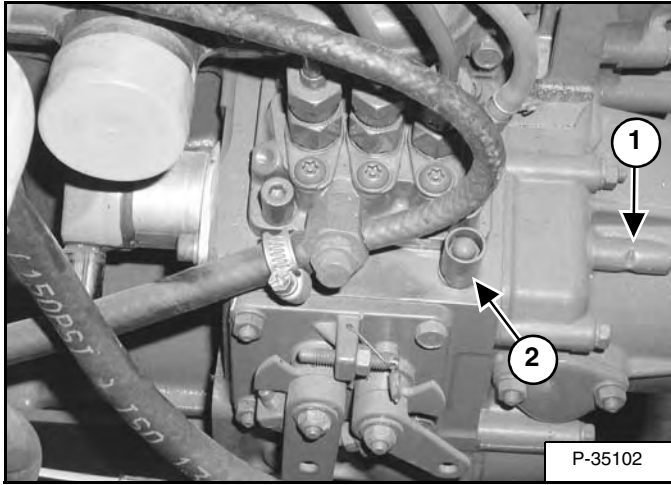

The idle limit adjustment (Item 1) and the fuel limit adjustment (Item 2) [Figure 70-80-25] have sealed caps.

**NOTE:** See your authorized Kubota dealer for proper adjustment before removing the caps.

### Exhaust Manifold Removal And Installation

Figure 70-80-26

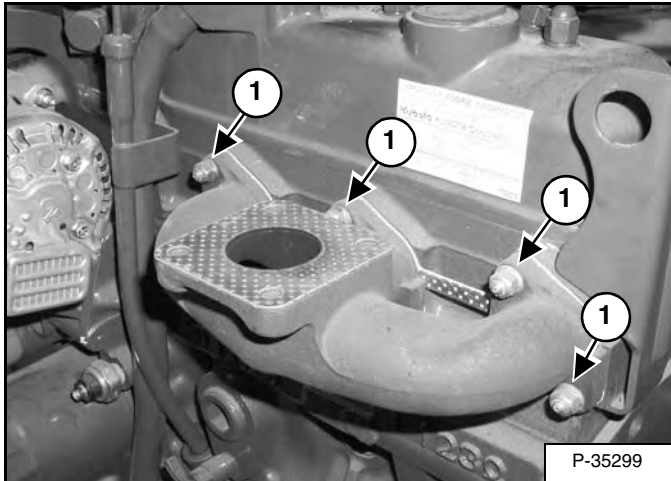

Remove the mounting nuts (Item 1) [Figure 70-80-26] from the exhaust manifold.

Figure 70-80-27

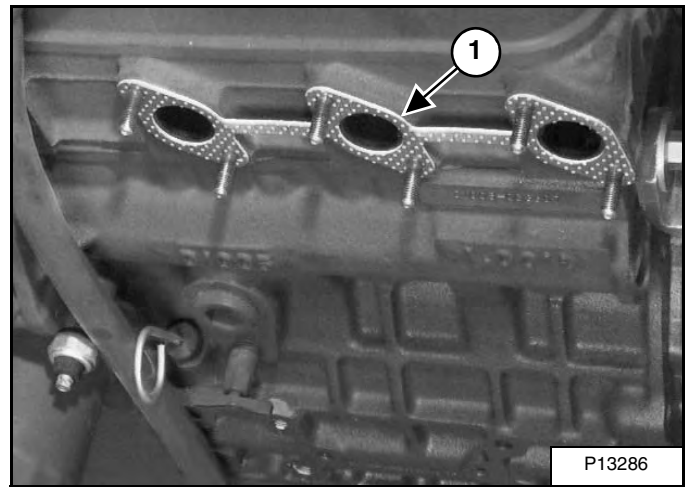

Remove the ex haust manifold from the engine and remove the exhaust manifold gasket (Item 1) [Figure 70-80-27] from the engine.

**Installation:** Replace the exhaust manifold gasket. Tighten the mounting nuts to 12 to 14 ft.-lb. (16 to 19 N•m) torque.

## RECONDITIONING THE ENGINE (CONT'D)

### Servicing The Cylinder Head (Cont'd)

Figure 70-80-55

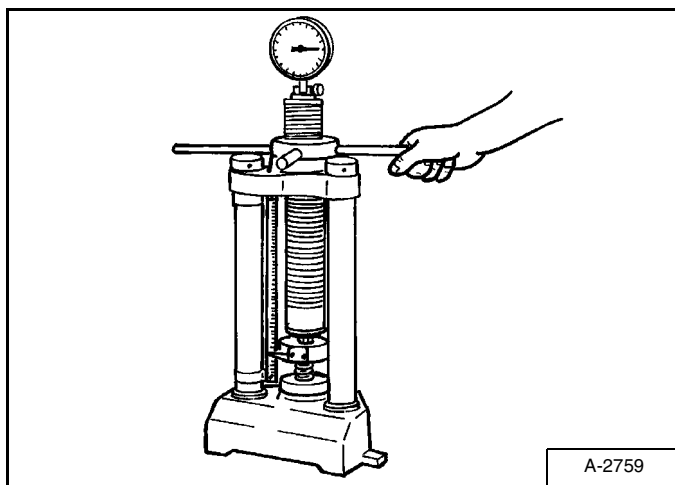

Put the valve spring in a tester **[Figure 70-80-55]**.

Push down on the spring 1.22 in. (31 mm). The compression load must be 26.4 lb. (11,97 kg). Replace the valve spring if it does not meet these specifications.

## RECONDITIONING THE ENGINE (CONT'D)

### Governor Shaft Removal And Installation (Cont'd)

Figure 70-80-88

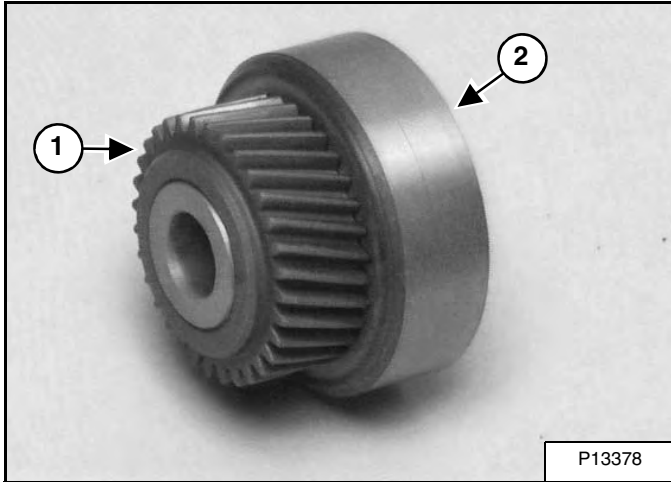

Remove the governor gear (Item 1) from the gear holder (Item 2) [Figure 70-80-88].

Figure 70-80-89

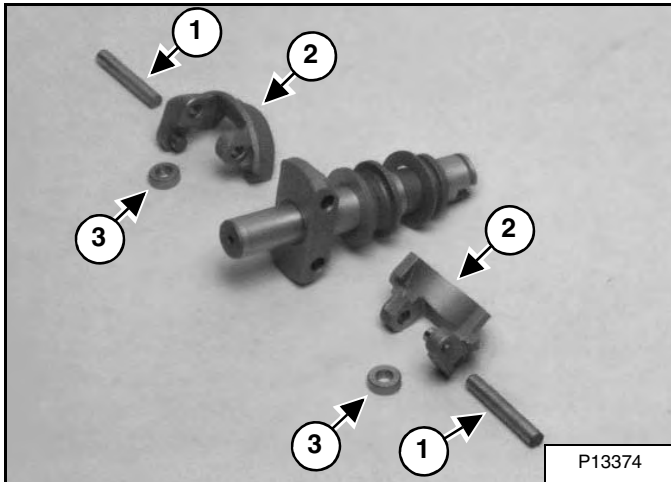

Remove the governor weight shafts (Item 1) from the governor weights (Item 2) [Figure 70-80-89].

Remove the governor weights.

Remove the rollers (Item 3) [Figure 70-80-89] from the governor weights.

Figure 70-80-90

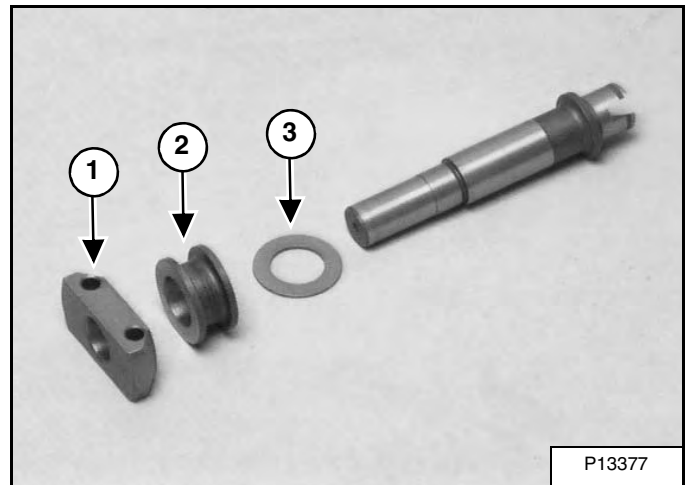

Remove the governor weight holder (Item 1) [Figure 70-80-90] from governor shaft.

Remove the governor sleeve (Item 2) and thrust washer (Item 3) [Figure 70-80-90] from governor shaft.

Check all parts and replace if needed.

## RECONDITIONING THE ENGINE (CONT'D)

### Checking Crankshaft Journal And Main Bearing

Figure 70-80-118

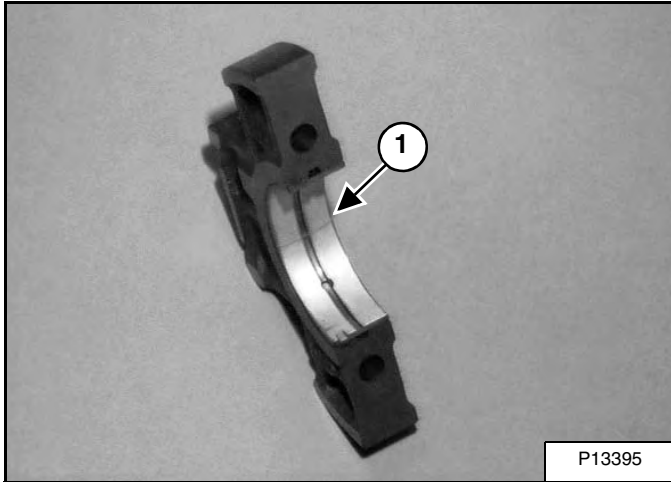

Clean the crankshaft journal and crankshaft bearing.

Put a strip of plastic gauge (Item 1) [Figure 70-80-118] on the main bearing.

Figure 70-80-119

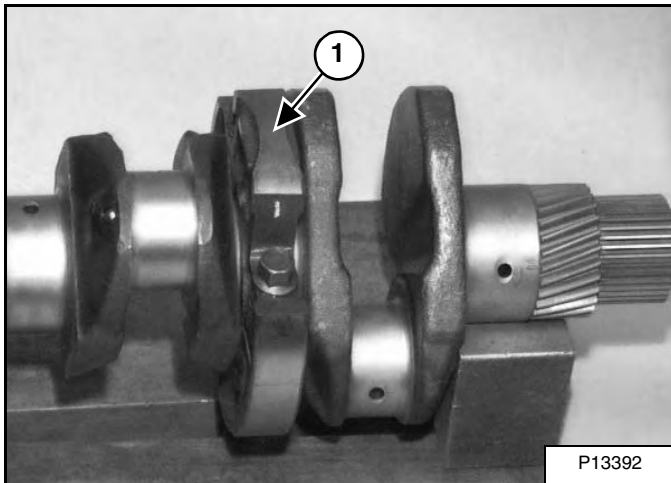

Install the main bearing cap (Item 1) [Figure 70-80-119] on the main bearing.

Figure 70-80-120

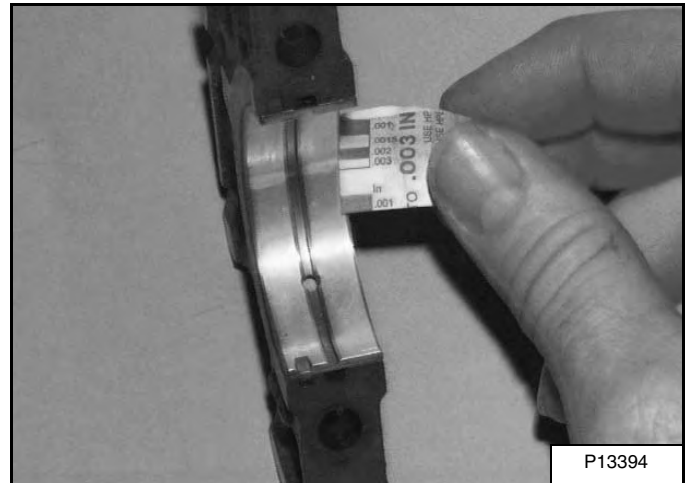

Remove the bolts and remove the main bearing cap and measure with the plastic gauge scale [Figure 70-80-120], to get oil clearance.

The oil clearance between crankshaft and crankshaft number two bearing is 0.0013 to 0.0037 in. (0,034 to 0,095 mm) with an allowable limit of 0.0079 in. (0,2 mm).

The oil clearance between the crankshaft and crankshaft number three bearing is 0.0013 to 0.0037 in. (0,034 to 0,095 mm) with an allowable limit of 0.0079 in. (0,2 mm).

The oil clearance between the crankshaft and crankshaft number four bearing is 0.0013 to 0.0039 in. (0,034 to 0,098 mm) with an allowable limit of 0.0079 in. (0,2 mm).

If the clearance exceeds the allowable limit, replace the crankshaft bearing.

## RUBBER DRIVE COUPLER

### Removal And Installation

Remove the engine. (See Removal And Installation on Page 70-70-1.)

Remove the flywheel housing. (See Removal And Installation on Page 70-90-1.)

Figure 70-110-1

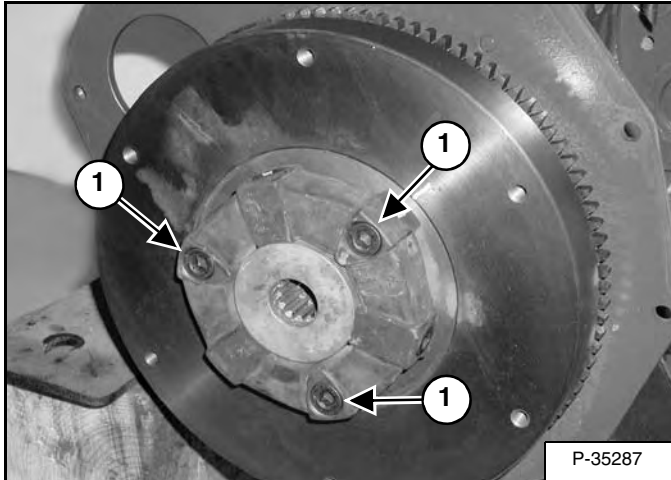

Remove the 3 drive coupler mounting bolts (Item 1) [Figure 70-110-1]. Remove the coupler.

**Installation:** Apply Loctite™ 242 or equivalent to the bolts and tighten to 25 to 30 ft.-lb. (34 to 40 N•m) torque.

Figure 70-110-2

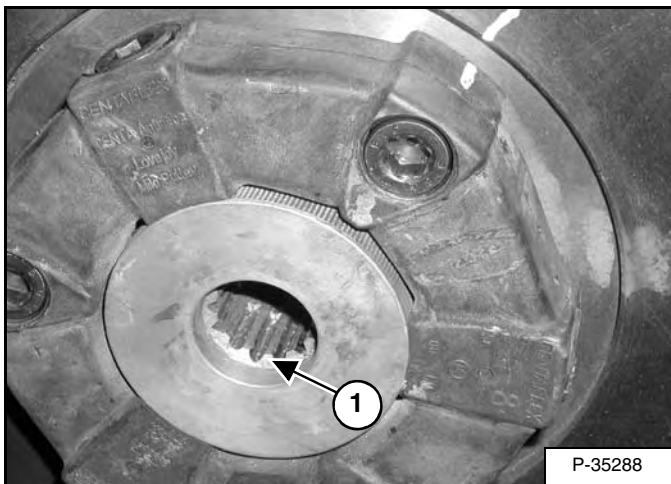

**NOTE:** When the drive coupler is installed correctly the recessed part of the coupler (Item 1) [Figure 70-110-2] is in position shown.

### Disassembly

Figure 70-110-3

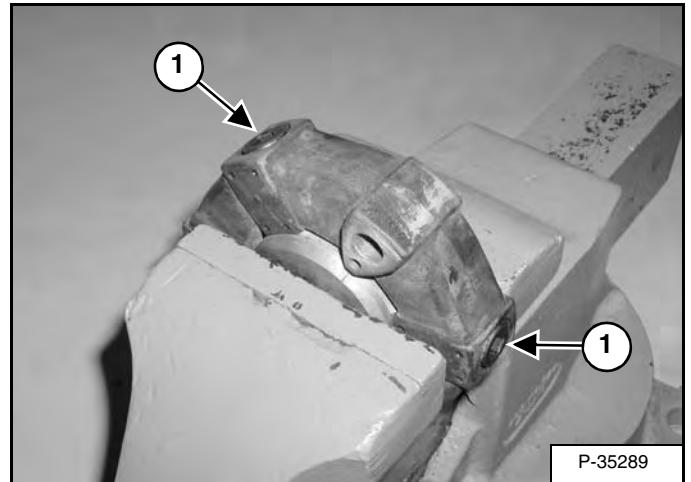

Put the coupler assembly in a vise and remove the 3 bolts (Item 1) [Figure 70-110-3].

Figure 70-110-4

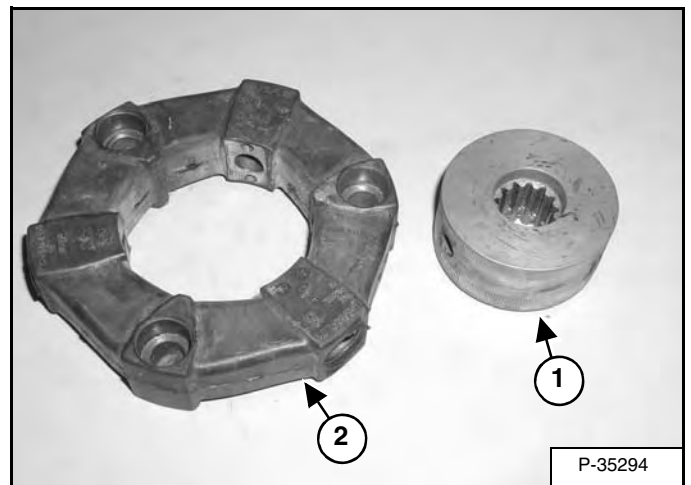

Remove the drive coupler (Item 1) from the rubber housing (Item 2) [Figure 70-110-4].

Inspect the drive coupler (Item 1) [Figure 70-110-4] for damage and replace as needed.

## HEATER FAN

### Removal And Installation

Figure 80-20-1

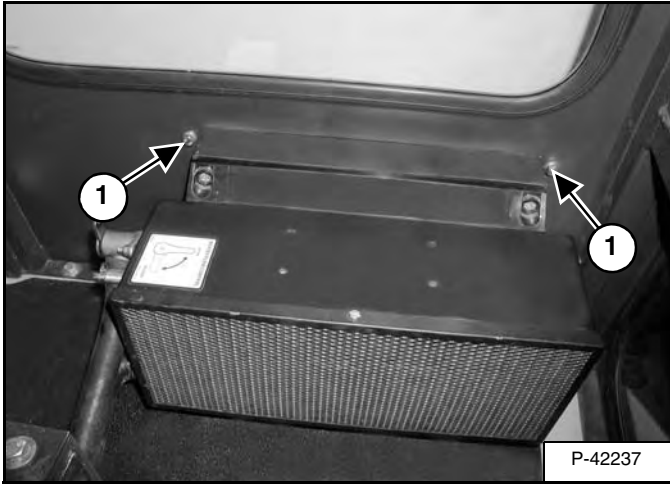

Remove the 4 mounting bolts (Item 1) [Figure 80-20-1] from the backside of the heater grill.

Installation: Tighten the bolts to 5 ft.-lb. (7 N•m) torque.

Figure 80-20-2

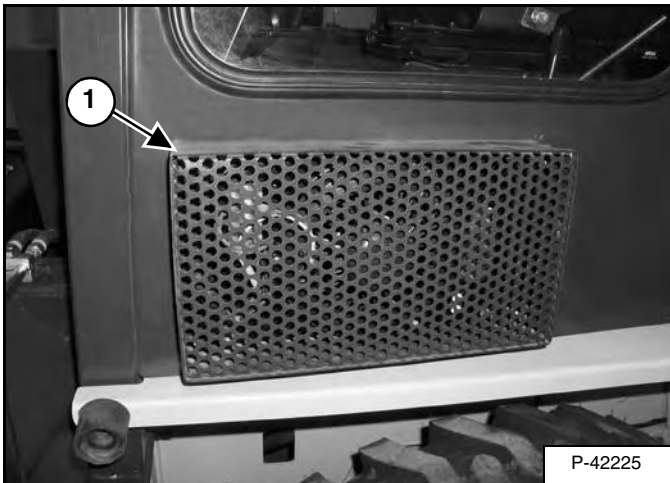

Remove the heater grill (Item 1) [Figure 80-20-2] from the outside of the cab.

Figure 80-20-3

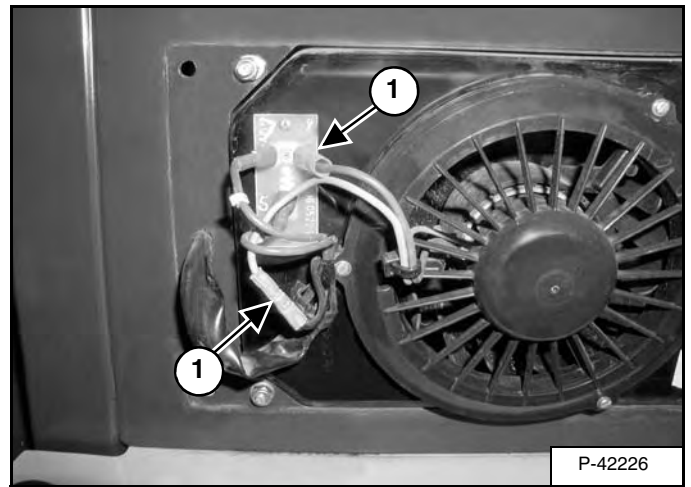

Disconnect the 2 wires (Item 1) [Figure 80-20-3].

**NOTE:** Mark the wires for correct assembly.

Figure 80-20-4

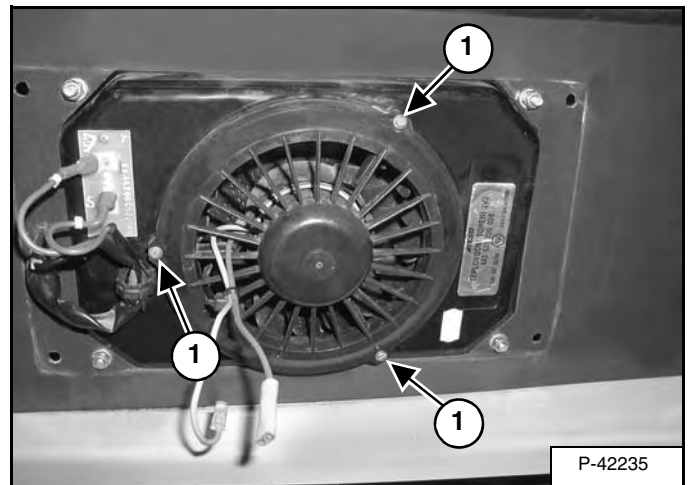

Remove the 3 fan motor mounting bolts (Item 1) [Figure 80-20-4].

## LOADER BACKHOE SPECIFICATIONS (CONT'D)

### Backhoe Rated Load Capacity (Per SAE J31)

- This chart shows the backhoe lifting capacity with the load applied at the bucket hinge pin and the machine equipped as outlined below.
- These figures are actual measured values, stated in pounds, and rated to SAE J31 (MAR86) standards. Stability limited values are indicated with an asterisk (\*) and are shown in light-face type. All values shown with **bold-face** characters are hydraulically limited.
- These values are based on a machine equipped as follows: 63" Loader Bucket (6962363) 16" Backhoe Bucket (6715501) 55 psi (379 kPa) Tire Pressure.
- Figures above the line are capacities over end. Figures below the line are capacities through the swing arc, with the swing frame fully side-shifted.
- Large arc shows boom lift capacity with dipper fully extended. Small arc shows dipper lift capacity with boom fully raised.

ALL LOAD VALUES ARE IN POUNDS

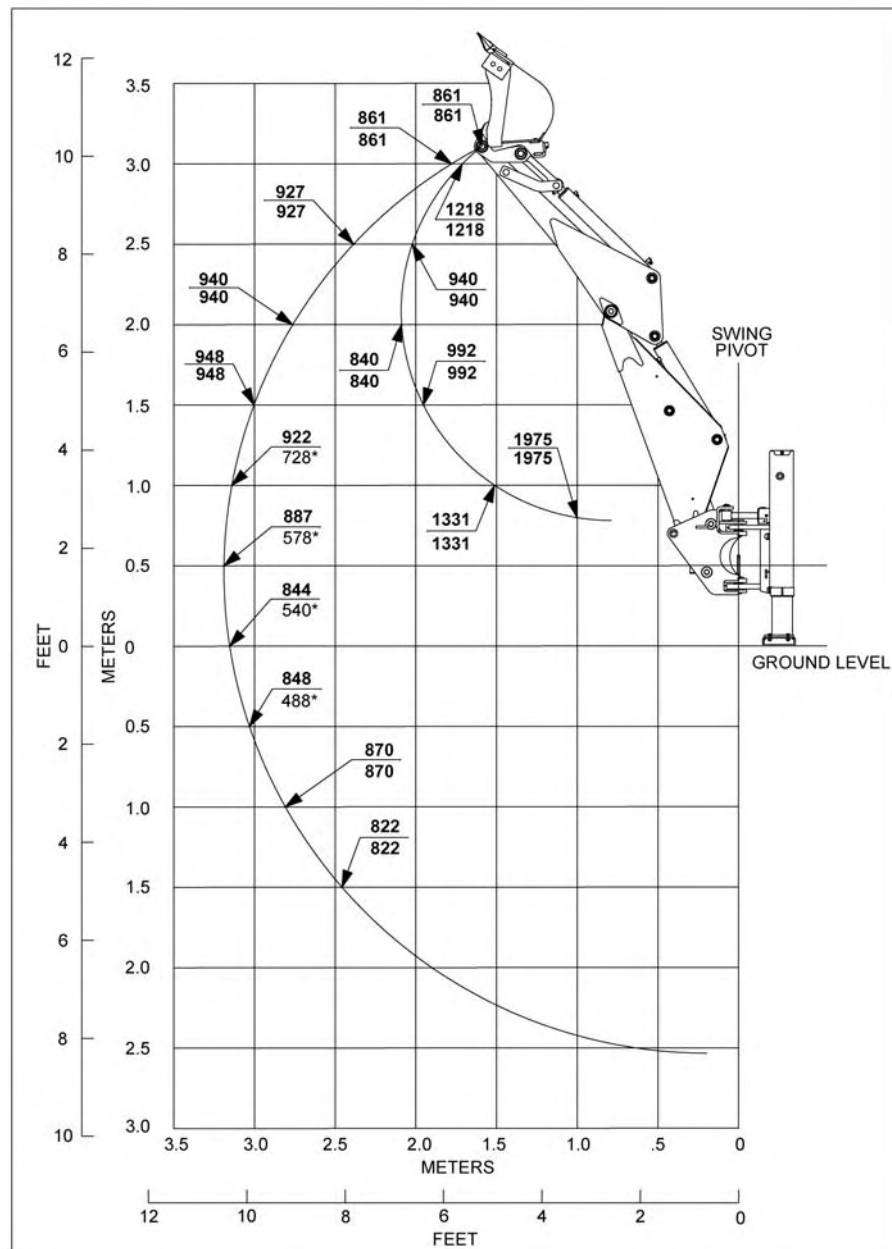

B-19983

## LOADER BACKHOE TORQUE

### Specifications

ITEM	FT.-LB.	N•M
Air Cleaner Mounting Bolts	18 to 19	24 to 26
Alternator Pulley Nut	50	68
Arm Cylinder Pivot Pin Retainer Bolt	18 to 19	24 to 26
Bob-Tach Pivot Pin Bolts	190	260
Bob-Tach Lever Pivot Bolt	25 to 28	34 to 38
Boom Cylinder Pivot Pin Retainer Bolts	18 to 19	24 to 28
Bucket Cylinder Pivot Pin Retainer Bolt	18 to 19	24 to 26
Camshaft Retainer Plate Bolts	7 to 8	9 to 11
Connecting Rod Bolts	30 to 34	41 to 46
Crankshaft Pulley Nut	101 to 116	137 to 157
Cylinder Head Bolts	48 to 51	64 to 69
Drive Coupler Mounting Bolts	25 to 28	34 to 37
Engine Mounting Bolts	32 to 35	43 to 47
Floor Panel Mounting Bolts	4 to 5	5.5 to 6.5
Flywheel Bolts	40 to 43	54 to 59
Fuel Camshaft Retainer Plate Bolts	7 to 8	9 to 11
Fuel Tank Mounting Bolts	55 to 60	75 to 85
Glow Plug	15 to 18	20 to 24
Grill Frame Mount Bolts	55 to 60	75 to 85
High Pressure Fuel Lines	18 to 25	24 to 33
Hydraulic Reservoir Mounting Bolts	55 to 60	75 to 85
Hydraulic Filter Housing Mounting Bolts	32 to 35	43 to 47
Hydrostatic Motor Mounting Bolts	55 to 60	75 to 85
Hydrostatic Pump Mounting Bolts	90 to 100	125 to 140
Idler Gear Shaft Bolts	7 to 8	9 to 11
Injection Pump Mounting Bolts & Nuts	17 to 20	23 to 27
Injection Nozzles	36 to 51	46 to 69
Injector Nozzle Body	43 to 58	59 to 79
Main Bearing Mounting Bolts	36 to 40	49 to 54
Main Bearing Cap Bolts	22 to 25	29 to 34
Main Relief Valve	35 to 40	47 to 54
Operator Cab Fastening Nuts	118 to 133	160 to 180
Rear Bearing Case Cover Bolts	13 to 15	18 to 20
Seat Belt Fastening Bolts	21 to 24	29 to 32
Seat Mounting Bolts	11 to 12.5	15 to 17
Seat Bar Pivot Bolts	25 to 28	34 to 38
Steering Linkage Lock Nuts	42 to 46	57 to 63
Tilt Cylinder Pivot Pin Retainer Bolt	18 to 19	24 to 26
Timing Gearcase Cover Bolts	13 to 17	18 to 23
Travel Pedal Mounting Bolts	25 to 28	35 to 39
Wheel Nuts	100	136

CLICK HERE TO **DOWNLOAD** THE COMPLETE MANUAL

- Thank you very much for reading the preview of the manual.
- You can download the complete manual from: [www.heydownloads.com](http://www.heydownloads.com) by clicking the link below



- Please note: If there is no response to CLICKING the link, please download this PDF first and then click on it.

CLICK HERE TO **DOWNLOAD** THE COMPLETE MANUAL