

Service Manual

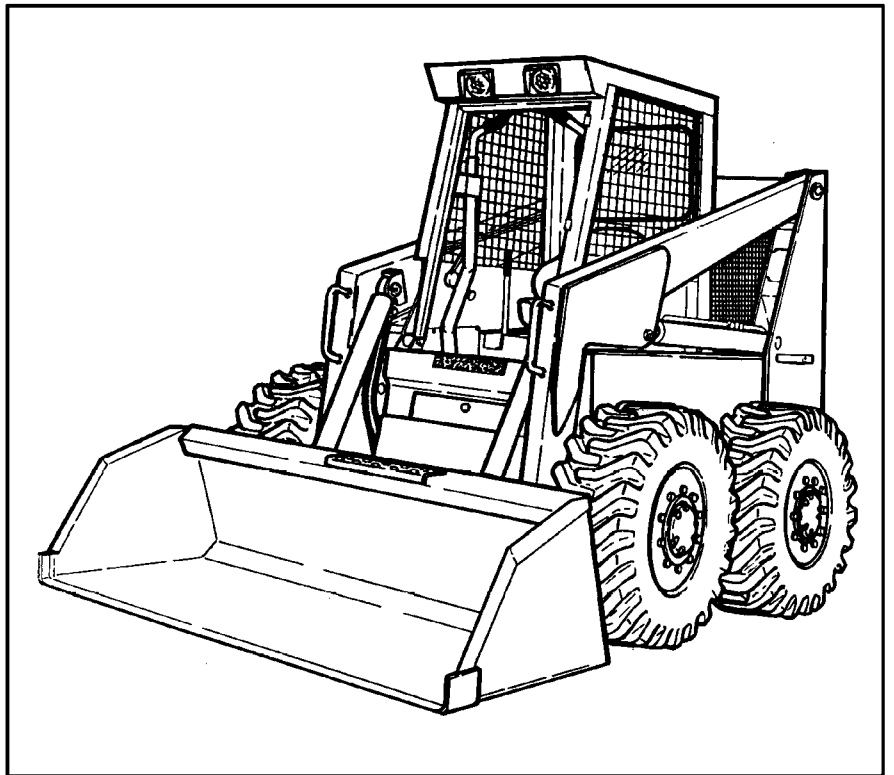

**MELROE
INGERSOLL-RAND**

6570341 (2-87)

Printed in U.S.A.



© Melroe Company 1987

CLICK HERE TO **DOWNLOAD** THE COMPLETE MANUAL

- Thank you very much for reading the preview of the manual.
- You can download the complete manual from: www.heydownloads.com by clicking the link below



- Please note: If there is no response to CLICKING the link, please download this PDF first and then click on it.

CLICK HERE TO **DOWNLOAD** THE COMPLETE MANUAL

III. SERIAL NUMBER LOCATIONS

Always use the serial number when requesting service information or when ordering parts. Early or later models (identification made by serial number) may use different parts, or it may be necessary to use a different procedure in doing a specific service operation.

LOADER SERIAL NUMBER

The Bobcat loader serial number plate location is inside front of the left upright, below the lift arm **A**.

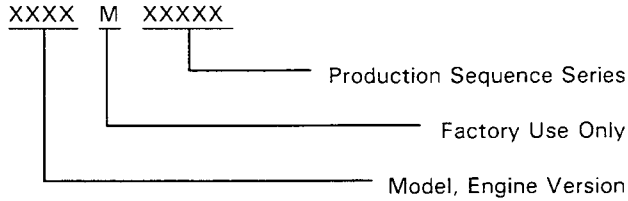

ENGINE SERIAL NUMBER LOCATION

The engine serial number is located on the right side of the engine block **B**.

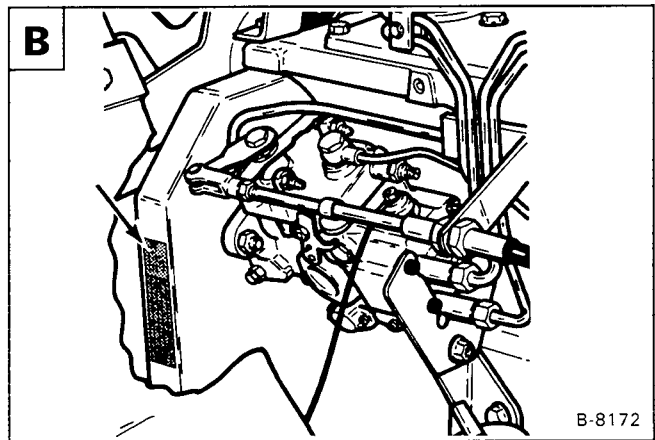
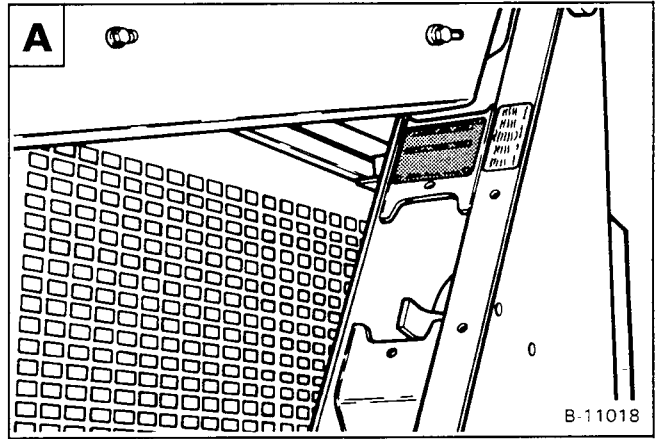

IV. DELIVERY REPORT

The Delivery Report must be filled out by the dealer and signed by the owner or operator when the Bobcat loader is delivered **C**. An explanation of the form must be given to the owner. Make sure it is filled out completely.

USING AN EXTRA BATTERY (JUMP STARTING)

Procedure

If it is necessary to use an extra battery to start the engine, be careful. This is a two person operation. There must be one person in the operator's seat and one person to connect and disconnect the battery cables.

Use the following procedure to connect the extra battery:

1. The key switch must be in the "OFF" position.
2. The extra battery must be of the same voltage as the loader battery.
3. Connect the end of the first cable to the positive (+) terminal of the extra battery. Connect the other end of the same cable to the positive (+) terminal of the loader battery **A**.
4. Connect the end of the second cable to the negative (-) terminal of the extra battery. Connect the other end of the same cable to the loader frame **A**.

NOTE: Do not connect directly to the negative (-) terminal of the loader battery. Connecting cable directly to the negative (-) terminal can cause a spark, causing the battery to explode.

5. Keep the cables away from the moving parts.
6. Start the engine (Also see Cold Starting Procedure in the Operator's Manual).
7. After the engine has started. Remove the cable connected to the loader frame first.
8. Remove the cable from the loader battery positive (+) terminal.

IMPORTANT

Damage to the alternator can occur if:

- Engine is operated with battery cables disconnected.
- Battery cables are connected when using a fast charger or when welding on the loader (Remove both cables from the battery).
- Extra battery cables (booster cables) are connected wrong.

I-2023-1285



WARNING

Keep arcs, sparks, flames and lighted tobacco away from batteries. When "jumping" from an extra battery make final connection (negative) at engine frame.

Do not jump start or charge a frozen battery. Warm battery to 60°F (16°C) before connecting to a charger. Unplug charger before connecting or disconnecting cables at battery. Battery gas can explode and cause serious injury.

W-2066-1285

Batteries contain acid which burns eyes and skin on contact. Wear goggles, protective clothing and rubber gloves to keep acid off body.

In case of acid contact, wash immediately with water for several minutes and get medical attention in case of eye contact.

W-2065-1286

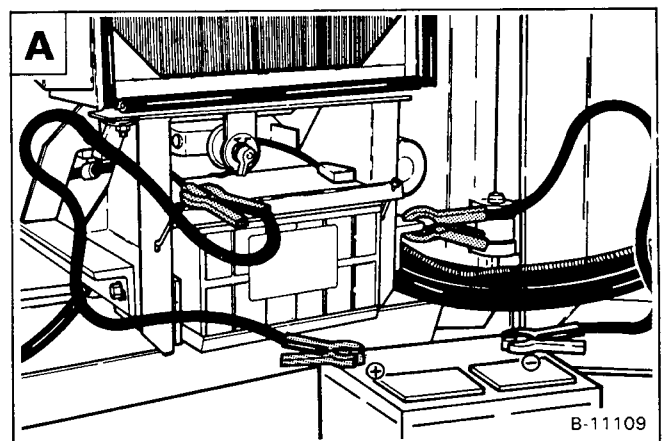

B-11109

980 Bobcat Loader
Service Manual

2 HYDRAULIC SYSTEM

TROUBLESHOOTING

The following troubleshooting chart is provided as an assistance in locating and correcting problems which are most common. Many of the recommended procedures must be done by authorized Bobcat Service Personnel only.

PROBLEM	CAUSE
The hydraulic system will not operate.	1, 2, 3, 4, 5, 6, 7, 8
Slow hydraulic system action.	3, 5, 6, 7, 8, 9, 10, 11
Hydraulic action is not smooth.	3, 7, 9, 10, 11
Lift arms go up slowly at full engine RPM.	3, 5, 8, 9, 10, 11, 12, 13
The lift arms or bucket will move with the pedal in neutral position.	11, 14
The lift arms come down with pedal in neutral.	11, 13, 15, 16, 17
The bucket does not self-level.	18, 19

KEY TO CORRECT THE CAUSE

1. Clutch is not engaged.
2. Clutch is damaged.
3. The fluid level is not correct.
4. The pedal linkage is disconnected.
5. The hydraulic pump has
6. 100 mesh screen is plugged.
7. Fluid is cold.
8. The relief valves have a defect.
9. The main relief valves are not at the correct pressure.
10. Suction leak at the inlet side of the hydraulic pump.
11. The pedal linkage is not adjusted correctly.
12. Using the loader for more than rated capacity.
13. Internal leak in the lift cylinder(s).
14. The spool in the valve section is not centering or centering spring is broken.
15. External leak at the lift cylinder(s).
16. Port relief seal is leaking.
17. Load check has a defect in the valve section.
18. Check the flow divider.
19. Check the unloading spool.

CONTROL VALVE (Cont'd)

Disconnect the return hose **A**.

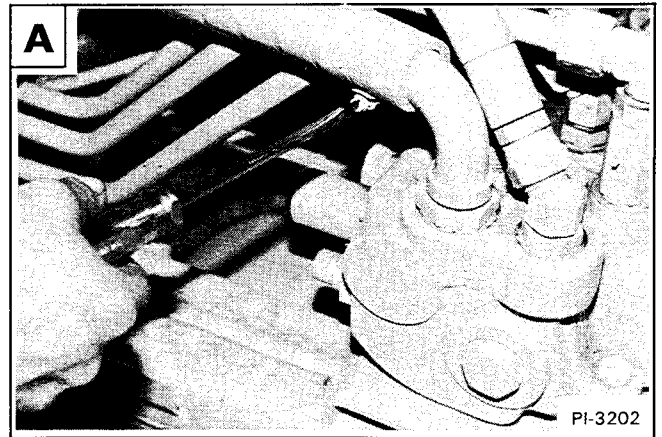

Disconnect the pressure hose and all the hoses at the control valve **B**.

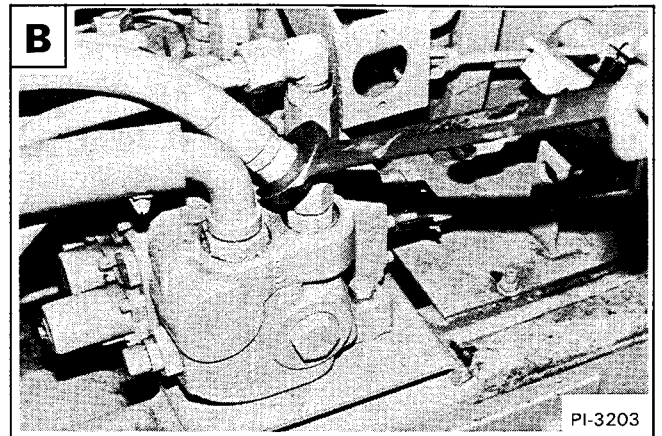

Disconnect all the tubelines **C**.

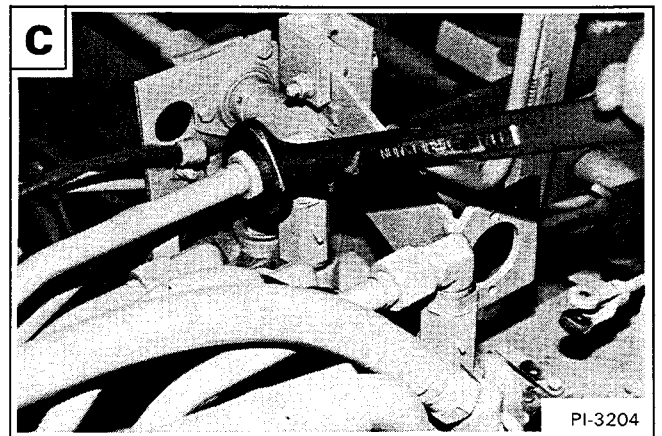

Remove the three mounting bolts and nuts **D**.

Installation: Tighten the bolts to 65-70 ft.-lbs. (88-95 Nm) torque.

Remove the control valve assembly from the loader.

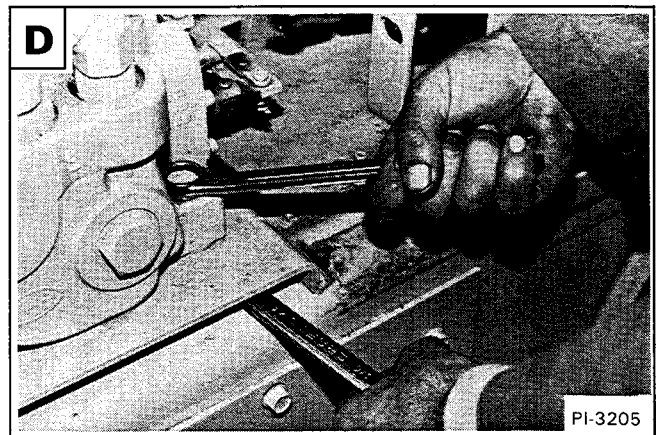

HYDRAULIC PUMP (Cont'd)

Put a punch through the bearing and against the metal case of the seal **A**.

NOTE: Do not let the punch rest against the bearing or the seal bore when removing the seal.

Inspection

Wash all the parts in clean solvent and use air pressure to dry them.

Make a visual inspection of all the parts and replace the parts as needed.

Check the bores in the gear plate. During the initial break-in the gears cut into the suction side. The nominal depth of this groove is 0.008" (0,203 mm) and must not exceed 0.015" (0,381 mm).

If the groove is deeper, the plate is cracked or damage in some other way, replace the plate.

Check the gears. If excessive wear is visible on the journals, sides or faces of the gears or at the point where the drive gears shaft rotates in the lip seal they must be replaced. If splines or key ways are worn, replace the gears.

Check the pressure plates. They must not show excessive wear on the bronze side. If deep grooved wear marks are visible, replace the pressure plates.

The bearing I.D. must have a gray coating. If bronze can be seen through the teflon on the suction side of the bearings and plate, replace with new parts.

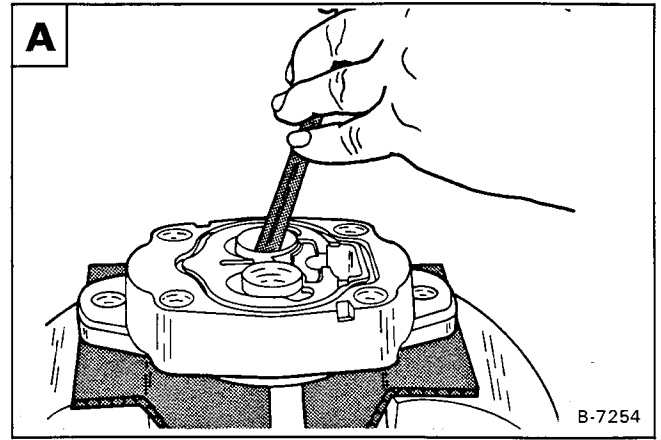

Assembly

NOTE: Always use new O-rings, gaskets and seals when assembling the pump.

Put two blocks of wood about 10" long on the work bench. Position them so they are parallel to each other and the drive shaft will go between them **B**.

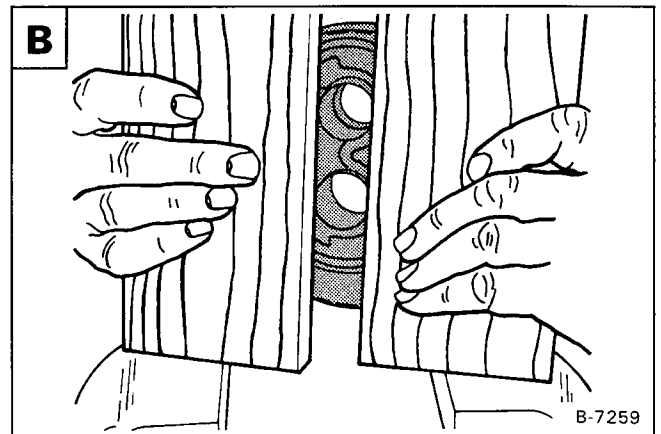

CONTROL PEDALS

Removal and Installation

Raise the operator cab (See Page 1–5).

Remove the right fender (See Page 5–10).

Disconnect the linkage at the lift pedal clevis **A**.

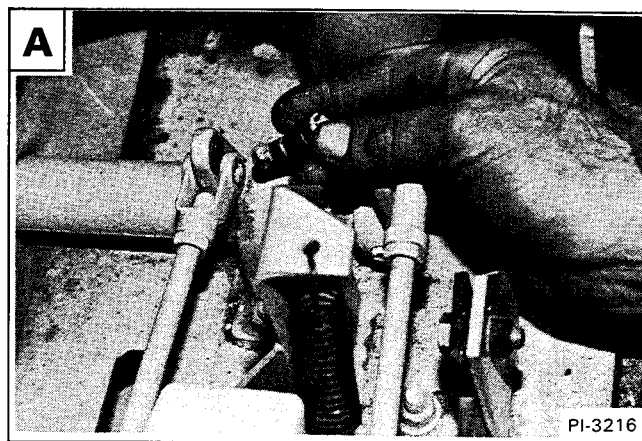

Disconnect the linkage at the tilt pedal arm **B**.

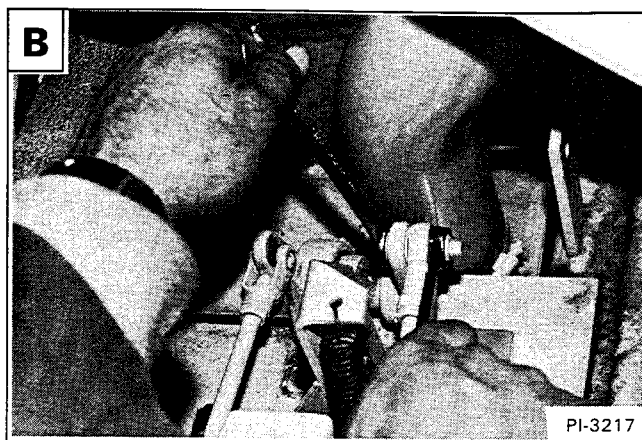

Loosen the set screw at the locking collar **C**.

Use a hammer and punch to loosen the locking collar.

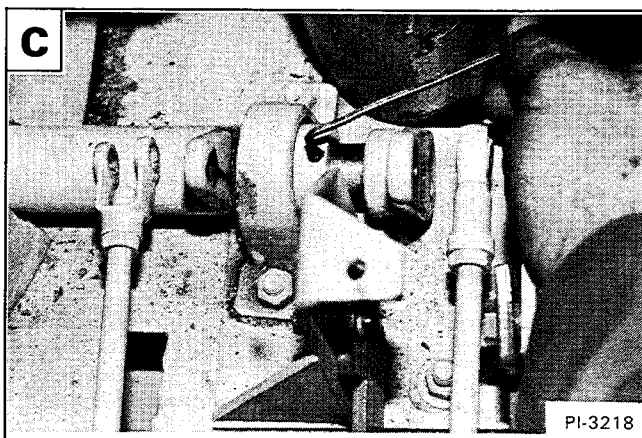

Remove the roll pin at the tilt pivot arm **D**.

NOTE: Be careful not to break the arm.

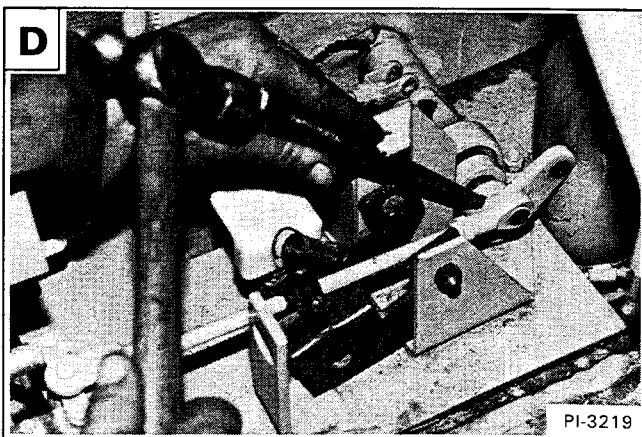

STEERING CONTROLS (Cont'd)

Remove both cam rollers **A**.

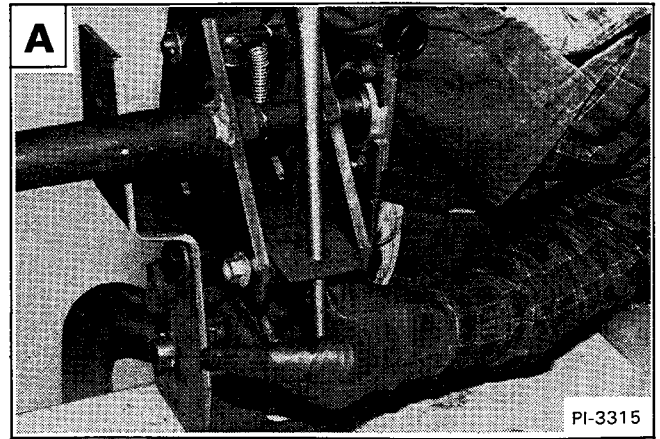

Remove the roller plate **B**.

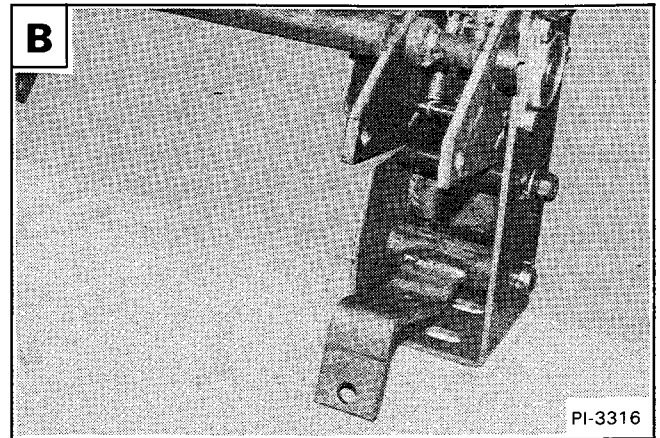

Remove the limiting rod **C**.

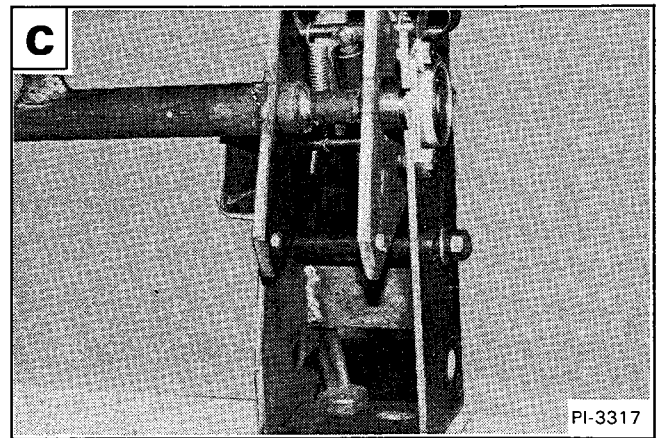

Remove the pivot bearing at the bracket **D**.

Remove the mounting bracket.

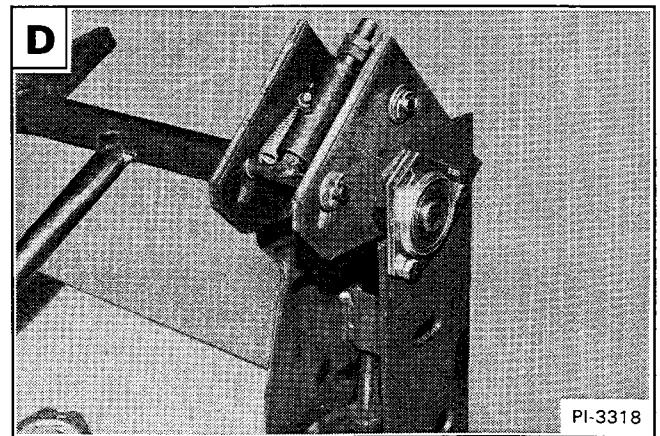

HYDROSTATIC PUMP (Cont'd)

Remove the rotating group **A**.

NOTE: When installing the rotating group, make sure the missing spline on the drive shaft and the splines that are close together (in the rotating group) are in correct alignment.

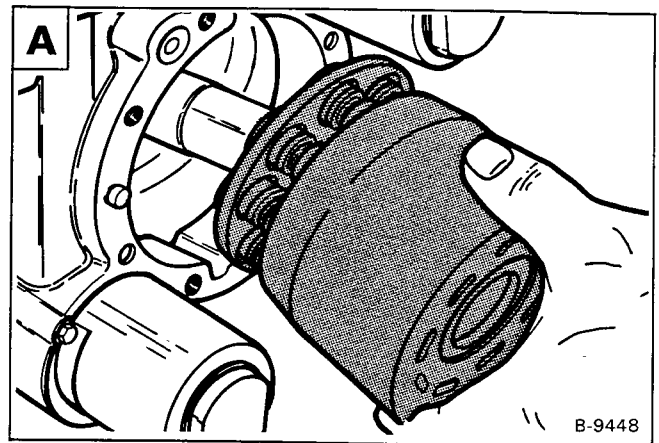

Mark the front cover for correct assembly **B**.

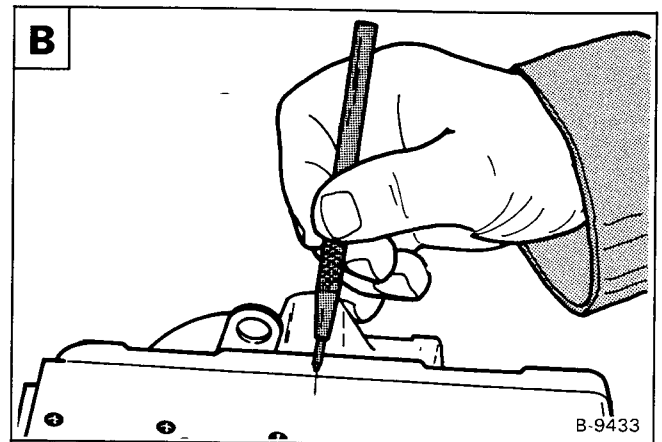

Remove the bolts at the front cover **C**.

Assembly: Tighten the bolts to 27-30 ft.-lbs. (37-41 Nm) torque.

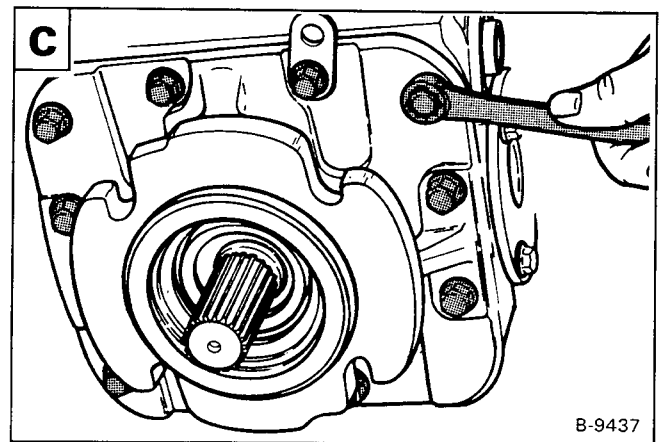

Remove the front cover from the housing **D**.

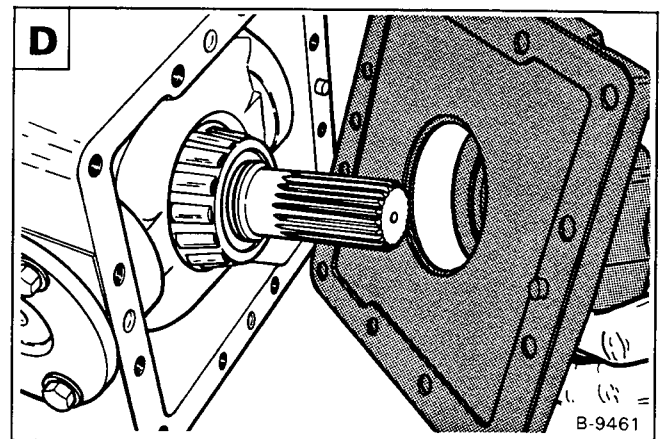

HYDROSTATIC MOTOR (Cont'd)

Remove the large snap ring at the drive end of the motor **A**.

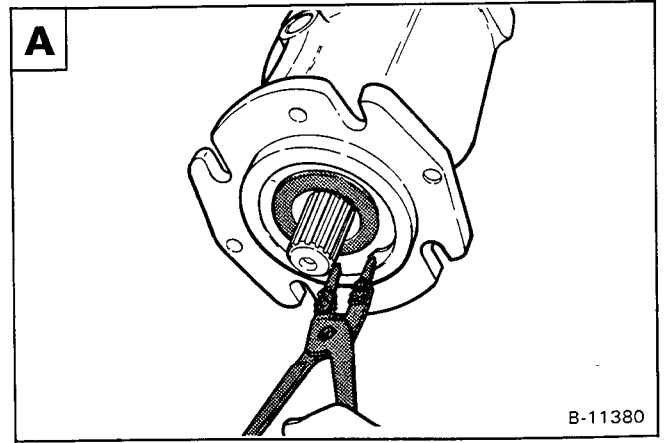

Use two screwdrivers, pry the seal from the housing **B**.

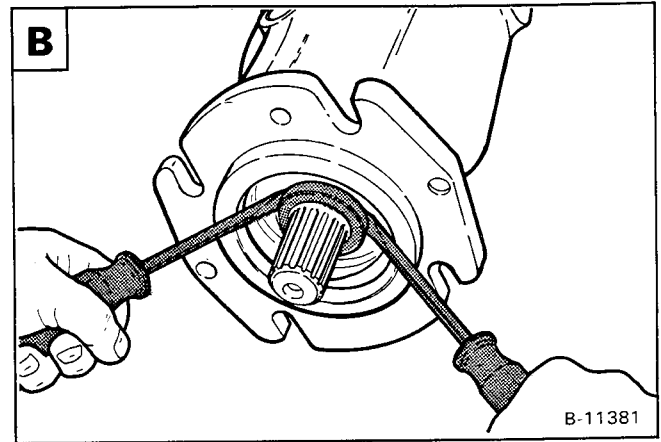

Assembly: Make sure the locating pin and slot (Item 1) are in alignment **C**.

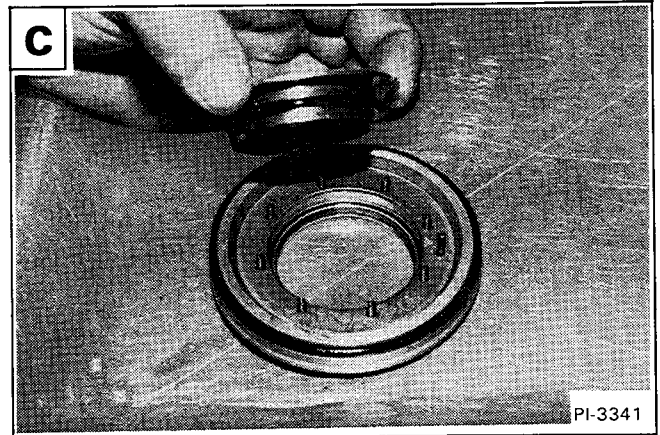

Using two screwdrivers, remove the bronze seal **D**.

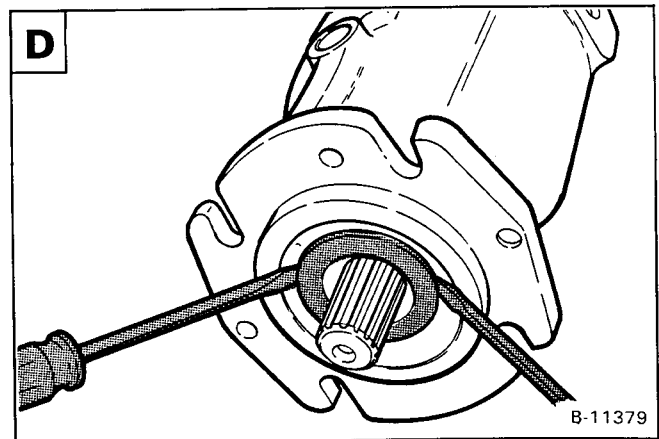

4 DRIVE SYSTEM

BRAKE/CLUTCH

See Page 4–7 for the Brake removal and installation.

Adjustment

IMPORTANT

The brake/clutch pedal must be disengaged when starting a cold engine. Engage the brake/clutch pedal at a slow rate to prevent damage to the hydrostatic system.

Use the following procedure to adjust the brake/clutch **A** :

1. Move the skid plate to the rear of the loader (See Page 1–4).
2. Lift and block the loader (See Page 1–2).
3. Remove the right side fender (See Page 5–10).
4. Disconnect the spring (Item 1) at the brake/clutch pedal.
5. Turn the adjustment bolt (Item 2) until it is even with the lock nut.
6. Loosen the left brake rod (Item 3) as much as possible.
7. Loosen the lock nut at the clutch linkage rod (Item 4).
8. Use the adjustment tube to position the brake/clutch pedal 0.50-0.75" (12,7-19,0 mm) from the rear of the cut out in the floor panel.
9. Connect the spring (Item 1). The brake/clutch pedal must touch the locking bar. The clutch is now adjusted.
10. Start the engine. Push the brake/clutch pedal all the way forward and hold.
11. Push both steering levers forward and hold. Let the brake/clutch pedal backwards at a slow rate until the wheels just start to move. Lock the brake/clutch pedal. Stop the engine.
12. Take out all the extra movement at the left brake linkage (Item 3).
13. Tighten the adjustment bolt (Item 2) to remove any movement. Tighten the lock nuts. The adjustment is now completed.

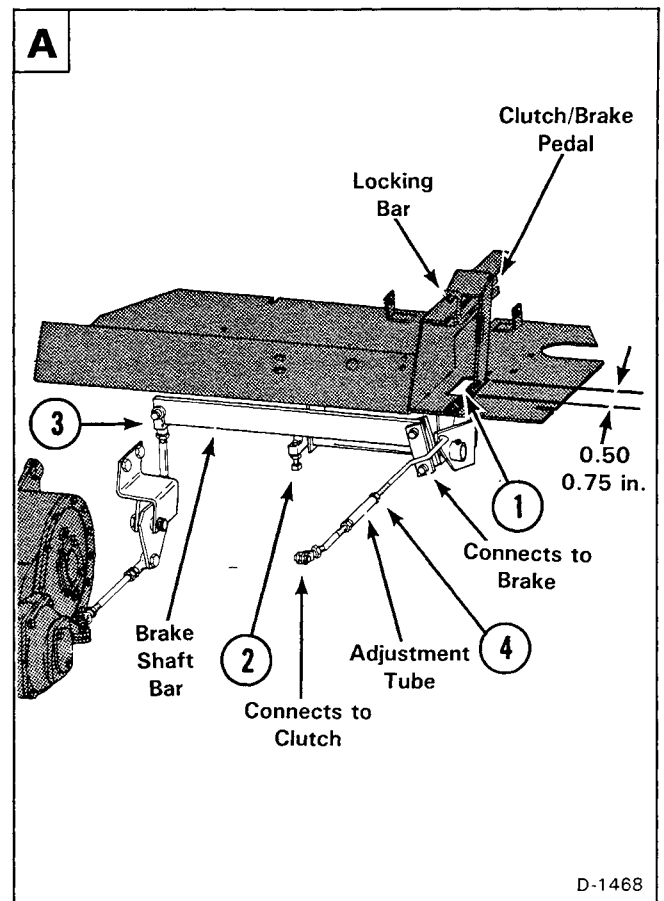

REDUCTION GEARCASE AND BRAKE (Cont'd)

Install a new seal using the correct size seal driver tool **A**.

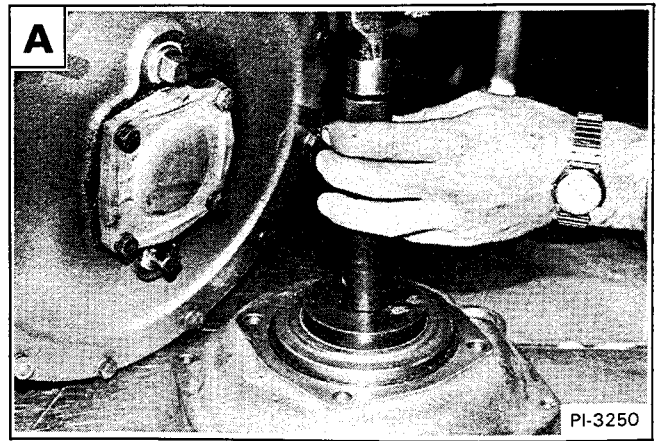

Remove the bolts and end plate **B**.

Assembly: Tighten the bolts to 25-28 ft.-lbs. (34-38 Nm) torque.

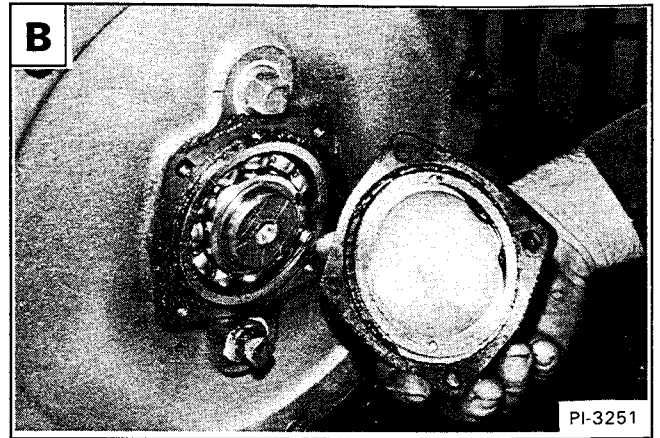

Remove the small snap ring at the output shaft bearing **C**.

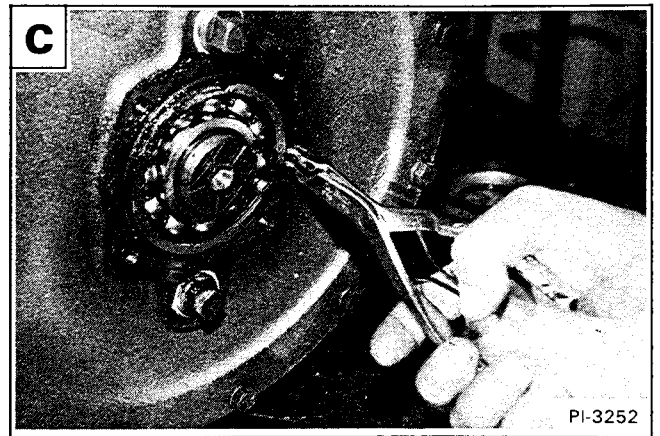

Remove the large snap ring at the output shaft bearing **D**.

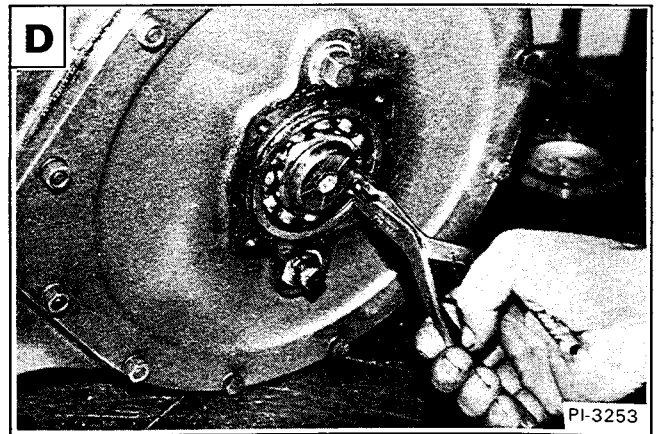

FINAL DRIVE CHAIN (Cont'd)

Install the idler sprocket assembly **A**.

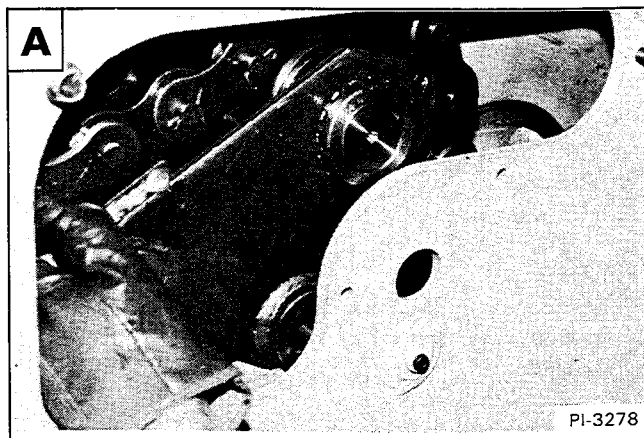

Install the pivot pin **B**.

Adjust the chain tension (See Page 4-17).

Add oil to the chaincase. It will take approximately 17 gals. (64 L) (each side).

Install the side cover and gasket. Tighten the bolts to 25 ft.-lbs. (34 Nm) torque.

Install the tire and wheel.

NOTE: If a new final drive chain was installed, check the chain tension after 100 hours of operation. Make the adjustment as needed.

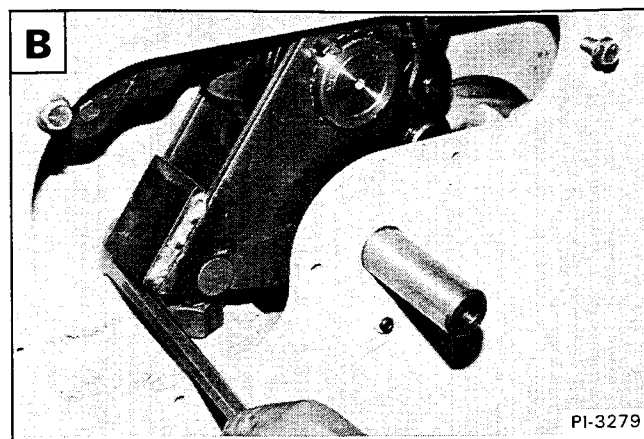

PLANETARY AXLE (Cont'd)

NOTE: If planetary axle cover is not machined for a quad-ring, use Permatex 515 (or equivalent) to seal the cover. If the quad-ring groove is present, use either a new quad-ring or Permatex 515 (or equivalent) to seal the cover.

Install the quad-ring into the outer hub **A**.

NOTE: The narrow edge of the quad-ring must face up. The quad-ring will extend above the inside surface of the hub.

Put sealant on the outer hub and install it. Install the six bolts with flat washers. Tighten the bolts to 35 ft.-lbs. (47 Nm) torque.

Test the assembly for leaks by adding air pressure of 12 PSI (83 kPa) for 15 seconds **B**.

Inspect the O-ring that seals the planetary carrier to the chaincase **C**. If it is in good condition, add heavy grease to the O-ring to hold it in position during installation of the planetary axle.

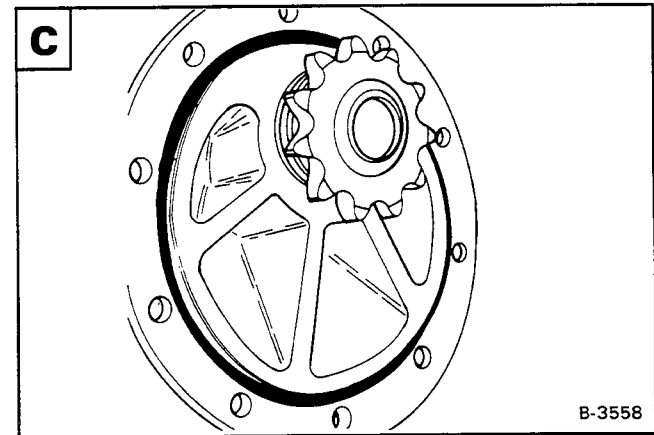
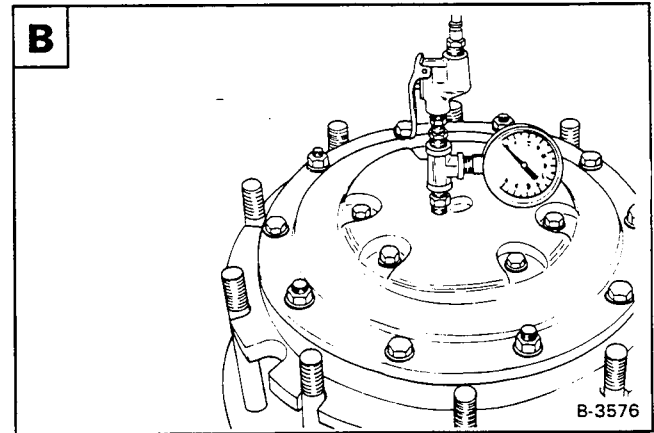
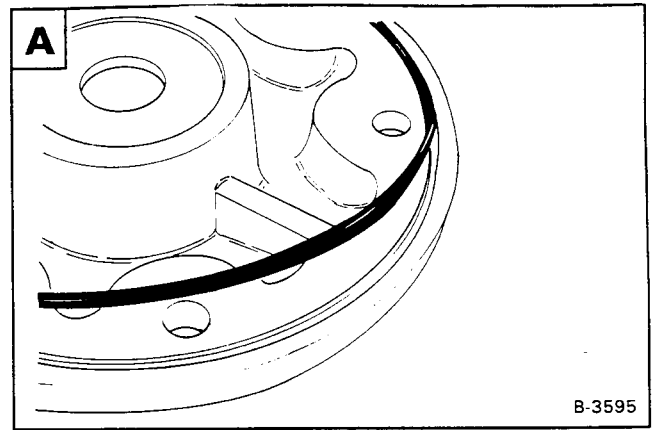

REAR DOOR (Cont'd)

Remove both hinge pins, using a punch and hammer **A**.

Lift the rear door from the loader.

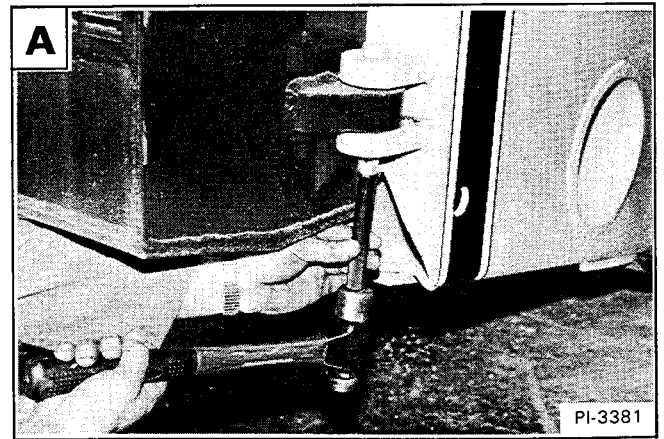

CLICK HERE TO **DOWNLOAD** THE COMPLETE MANUAL

- Thank you very much for reading the preview of the manual.
- You can download the complete manual from: www.heydownloads.com by clicking the link below



- Please note: If there is no response to CLICKING the link, please download this PDF first and then click on it.

CLICK HERE TO **DOWNLOAD** THE COMPLETE MANUAL

ENGINE HARNESS

WIRE LEGEND

NO.'s	COLOR	GAUGE
1A	Red	1/0
1B	Red	10
1D	Red	10
1F	Red	12
10D	Black	1/0
14F	Lt. Green	14
14R	Lt. Green/White	14
19CT	Red/White	10
21S	White/Lt. Green	10
23F	White/Black	14
32T	Yellow/Black	16
36P	Purple/Orange	16
36T	Purple/White	16
41	Pink	14
41L	Pink	14
42R	Dk. Blue/White	14
42RL	Dk. Blue/White	14
50	Black	10
66CR	Blue	10
66CT	Green	10

PARTS LEGEND

1	Rear Lights Connector	14	Alternator
2	Harness Connector	15	Diode
3	Rear Lights	16	Fuel Shut-off (Injection Pump)
4	Frame Ground	17	Engine Coolant Temperature Sender
5	Quick Start (Optional)	18	Hydrostatic Fluid Temperature Switch
6	Operator Cab Tilt Pump	19	Engine Oil Pressure Sender
7	Operator Cab Tilt Switch		
8	Starter		
9	Circuit Breaker (Operator Cab Tilt)		
10	Battery		
11	Battery Disconnect Switch		
12	Engine Ground		
13	Fuel Tank		

STARTER

Checking the Starter

The key switch must be in the "off" position.

The battery must be at full charge.

The cable connections must be clean and tight.

Connect a jumper wire between "S" terminal and "BAT" terminal **A**. If the starter turns but does not turn the engine, the starter drive has a defect.

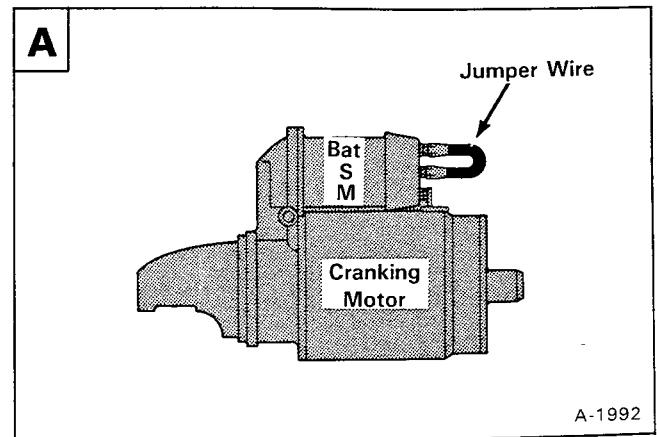

Connect a jumper wire between "M" terminal and the "BAT" terminal **B**. If the starter turns, the defect is in the solenoid. If the starter does not turn, the starter is defective.

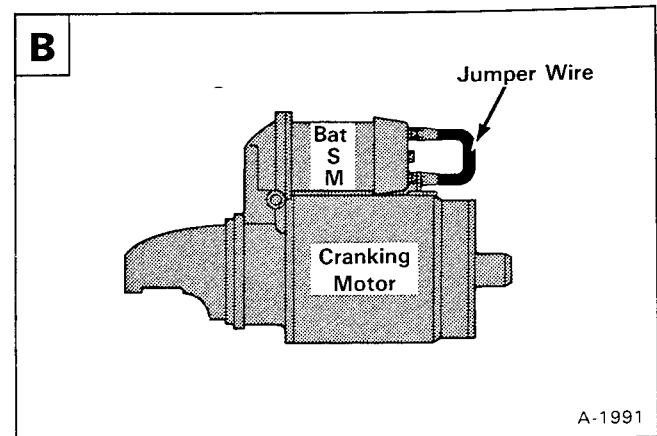

Removal and Installation

Turn the disconnect switch to the "off" position.

Disconnect the cable at the "BAT" terminal of the solenoid **C**.

Disconnect the other wires at the solenoid **C**.

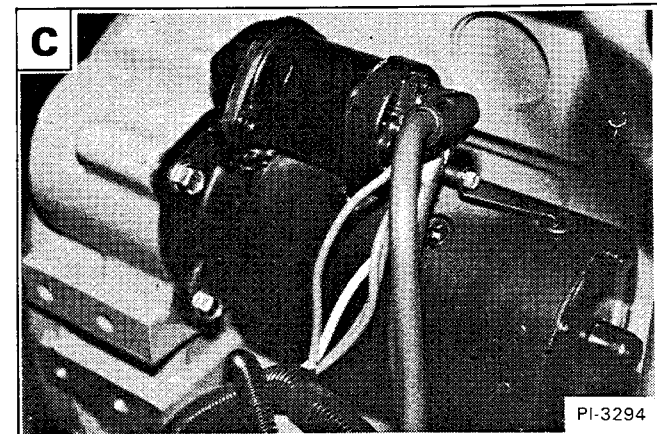

Remove the three mounting bolts **D**.

Remove the starter.

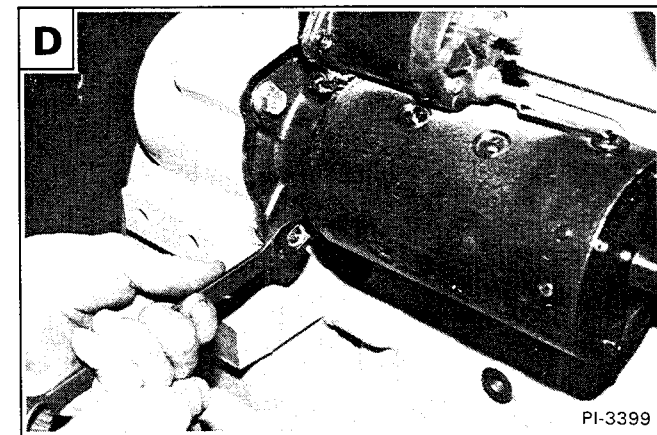

VALVE CLEARANCE

Adjustment

Make the valve clearance adjustment with the engine stopped and cold.

Remove the rocker arm covers.

Locate TDC for No. 1 cylinder by turning the engine crankshaft, while pushing in the timing pin until it engages **A**.

NOTE: The timing pin is designed only for locating TDC. Always disengage the timing pin before turning the engine.

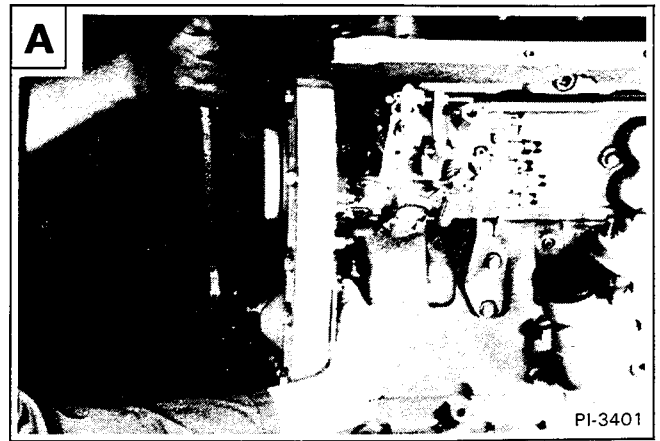

Loosen the adjusting screw **B**.

Adjust the intake valve clearance to 0.010" (0,25 mm) **B**.

Adjust the exhaust valve clearance to 0.020" (0,51 mm) **B**.

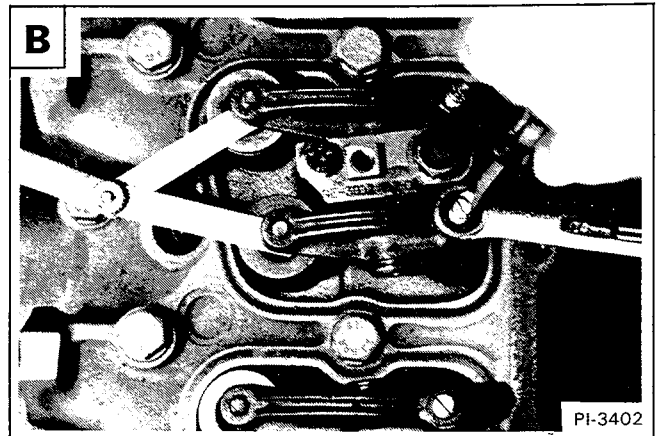

With the engine at TDC on No. 1 cylinder, set the valve clearance at intake valves of No. 1 and 2, exhaust valves of No. 1 and 3 **C**.

Rotate the crankshaft one full turn.

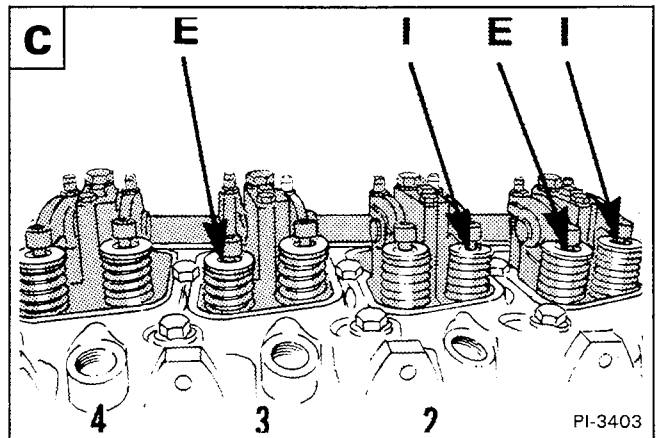

Set the valve clearance at the intake valves of No. 3 and 4, exhaust valves of No. 2 and 4 **D**.

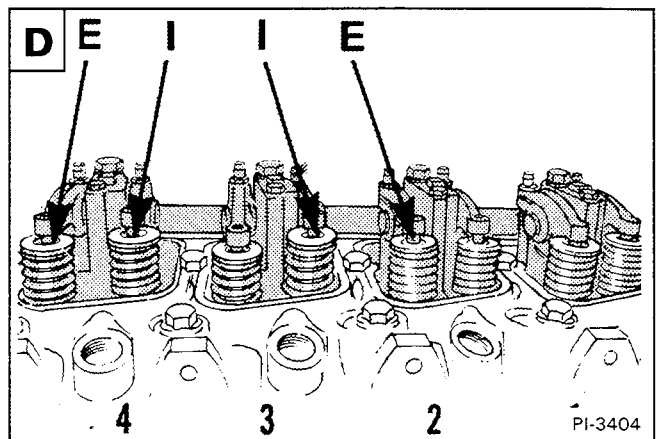

TIMING PIN

Timing Pin Replacement

The timing pin can be replaced without removing the assembly from the gear housing.

Remove the timing pin by prying the retainer ring out with a small screwdriver **A**.

Install a new O-ring, lubricate the pin and position it in the housing. Install a new retainer ring.

NOTE: Do Not remove the timing pin assembly from the gear housing unless gear housing is replaced. If the timing pin assembly is removed, it must be correctly aligned to obtain exact TDC.

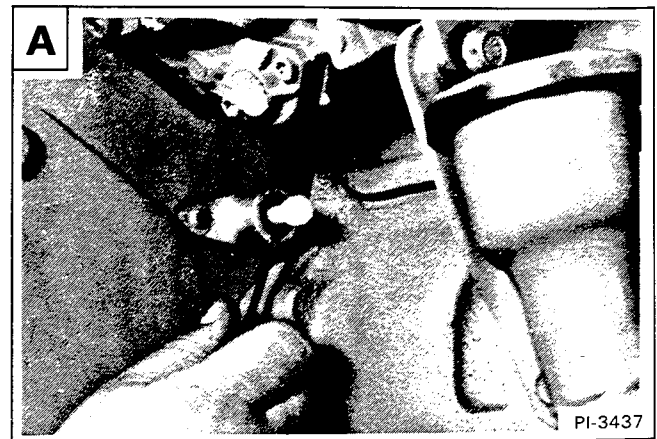

Timing Pin Alignment

Make a steel plate as shown **B**.

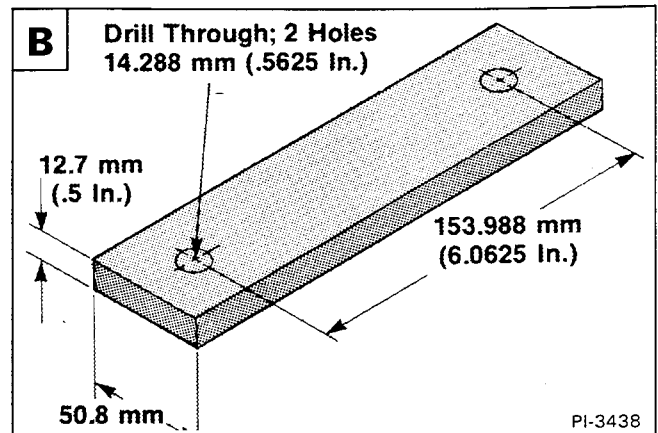

Install the plate over the No. 1 cylinder **C**.

Install the crankshaft pulley.

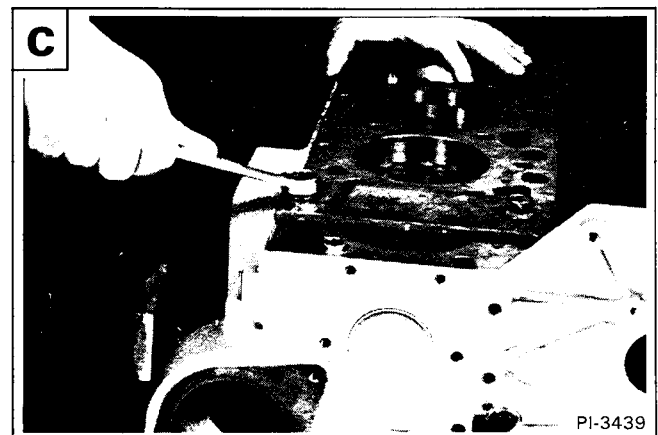

Fabricate a wire pointer over the crankshaft pulley **D**.

Rotate the crankshaft until piston contacts the plate.

Mark the pulley where the wire pointer indicates **D**.

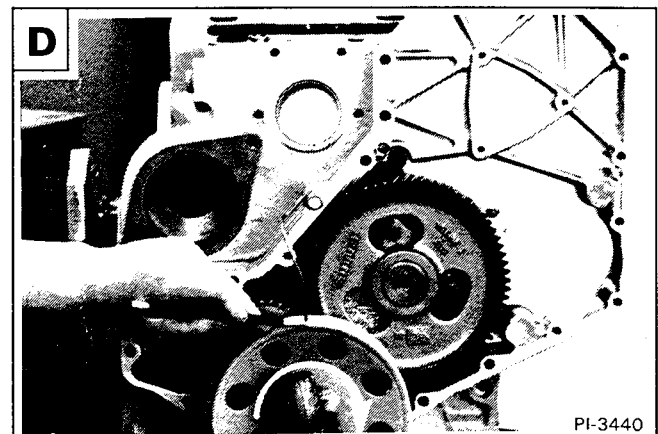

TURBOCHARGER AND EXHAUST MANIFOLD (Cont'd)

Disassembly

Mark the housing for correct assembly.

Install the turbocharger in a vise **A**.

Remove the compressor housing bolts, lock washers and clamp plates.

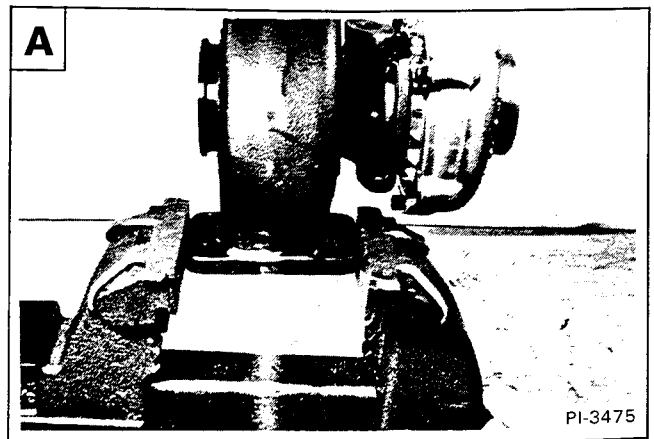

Remove the compressor housing and inspect for impeller contact **B**.

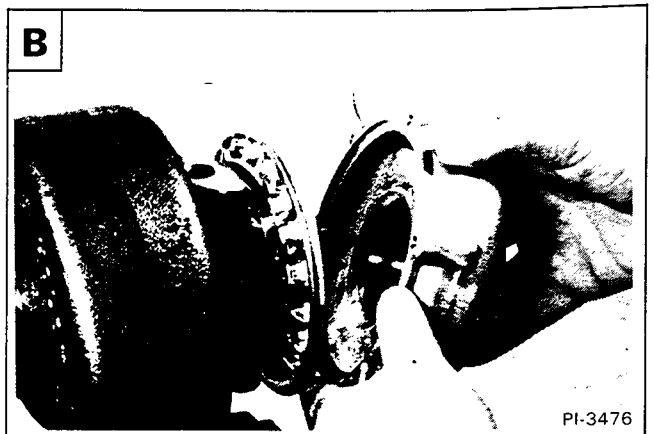

Remove the impeller nut **C**.

NOTE: Turn the nut to the right to loosen. The nut and the shaft have left hand threads.

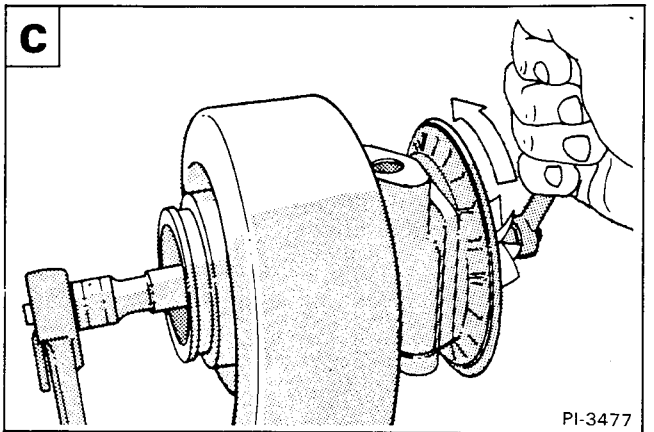

Remove the impeller and inspect the blades for damage **D**.

NOTE: The wheel and shaft assembly is balanced as a unit. If the impeller is damaged the complete assembly must be replaced.



TURBOCHARGER AND EXHAUST MANIFOLD (Cont'd)

Install the turbocharger and tighten the nuts **A**.

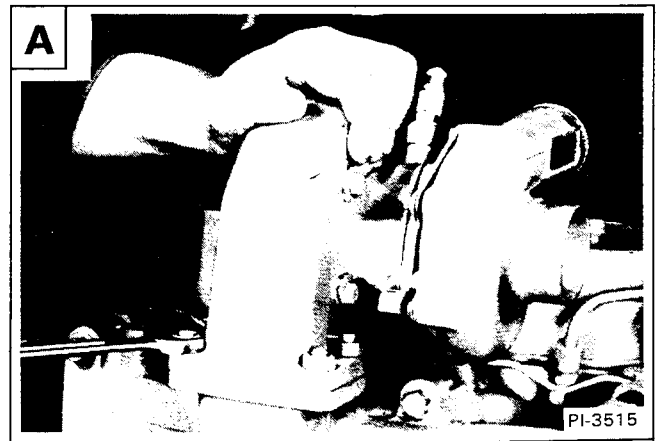

Loosen the turbine housing bolts and position the bearing housing to install the turbocharger drain tube **B**.



Install the hose and clamps on the turbocharger drain tube loosely. Install the drain tube and gasket on the turbocharger.

Tighten the bolts to 18 ft.-lbs. (24 Nm) torque **C**.

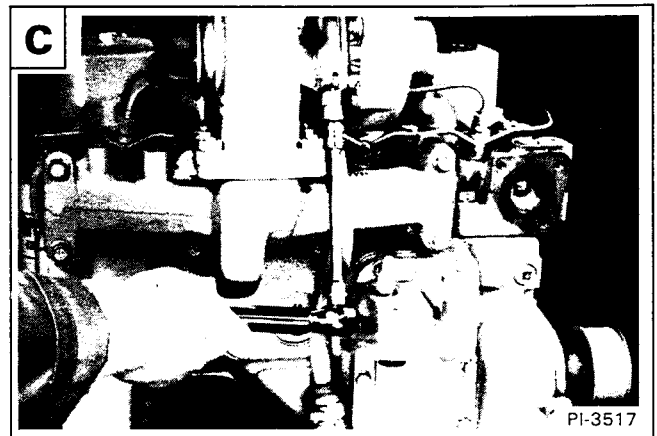

If the drain tube in the block was removed, apply sealant to the sealing surface **D**.

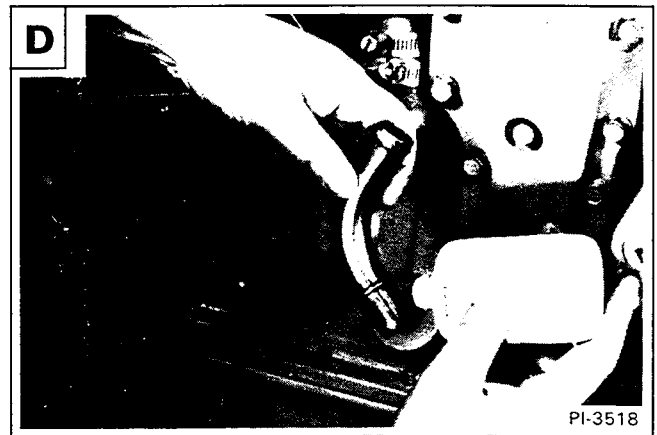

ROCKER ARMS AND PUSH RODS

Removal

Loosen the nuts and adjustment bolts at the rocker arms **A**.

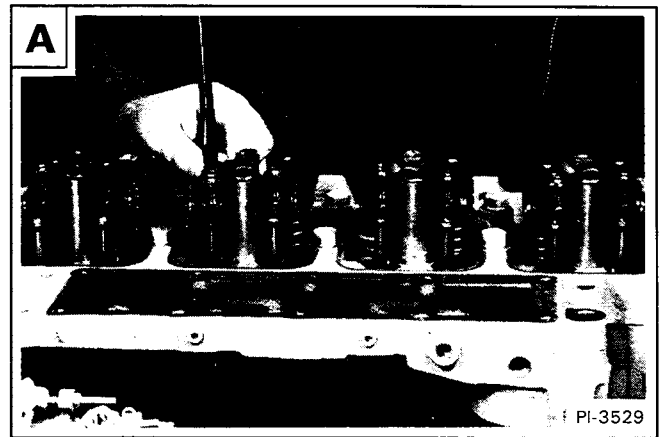

Remove the 8 mm bolts from the rocker arm shaft pedestals **B**.

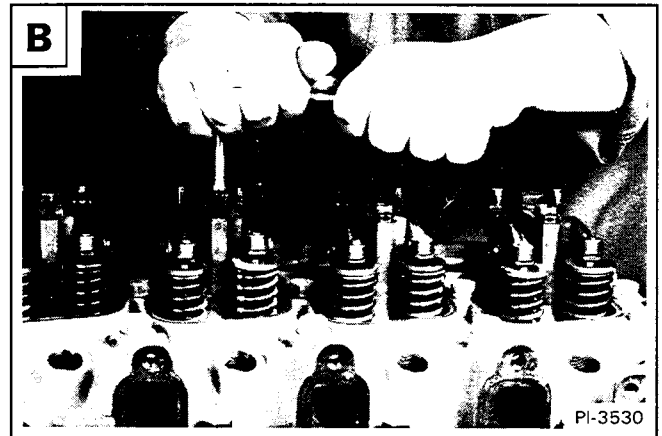

Remove the 12 mm bolts from the rocker arm pedestals **C**.

Remove the pedestals and rocker arm assemblies from the cylinder head.

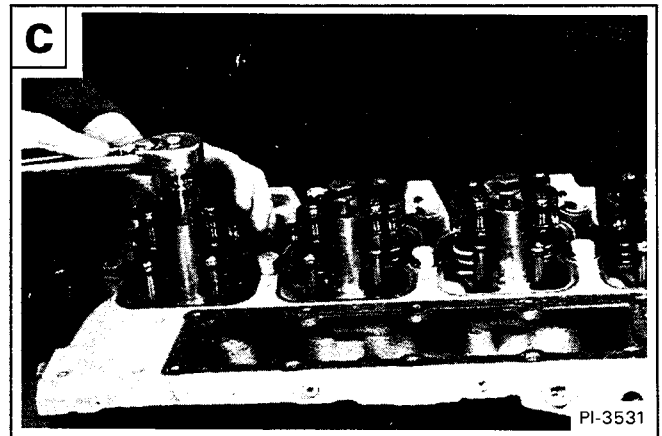

Remove the push rods **D**.

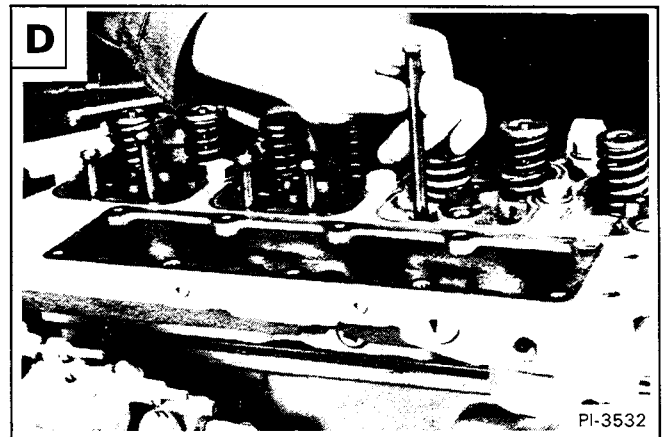

VALVES, GUIDES AND SPRINGS (Cont'd)

Grind the valve seats to remove scores, scratches and burns **A**.

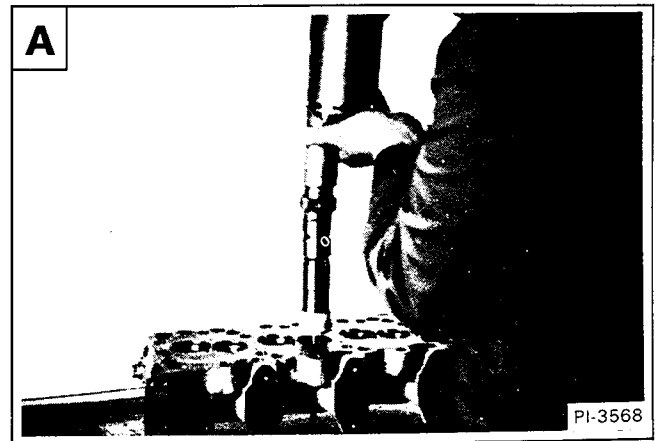

Install the valves in their respective bores and measure the depth again. Record the depth of each valve **B**.

Calculate the grinding depth as follows:

Grinding Depth = Reading from (Item B) minus first reading (item A).

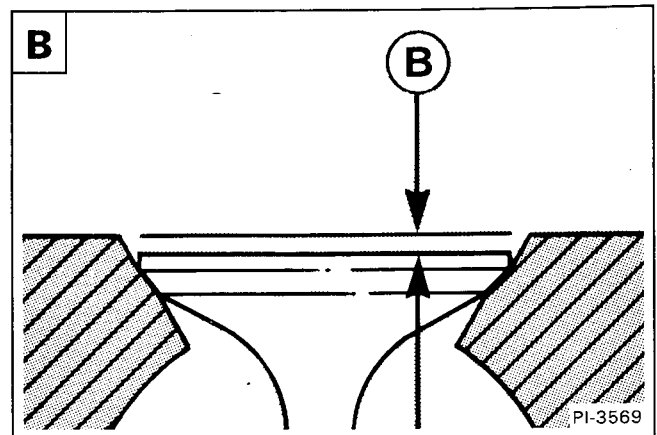

The maximum grinding depth is 0.010" (0,25 mm) **C**.

Replace valve seats that exceed that limit.

Grind the valve seats that were replaced.

Install valves in their respective bores.

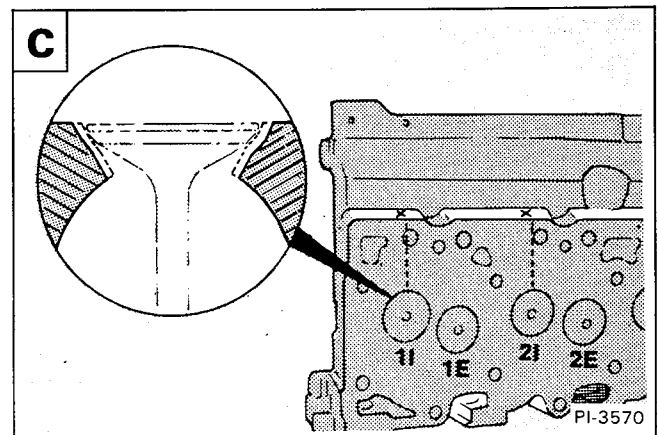

Measure the valve depth **D**.

The acceptable depth is 0.039-0.060" (0,99-1,52 mm).

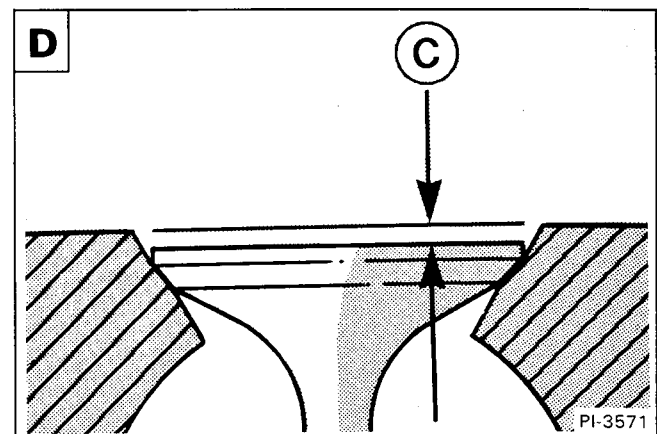

PISTON AND CONNECTING ROD (Cont'd)

Installation

Install the bearings into both the connecting rod and cap, make sure the notch is in the slot **A**.

Lubricate the rings and piston skirt with clean engine oil.



Using a ring compressor, compress the rings **B**. If using a strap-type ring compressor, make sure the inside of the strap does not hook the end of a ring and break it.



Position the piston and rod assembly into the cylinder bore with the mark "FRONT" toward the front of the engine block **C**.

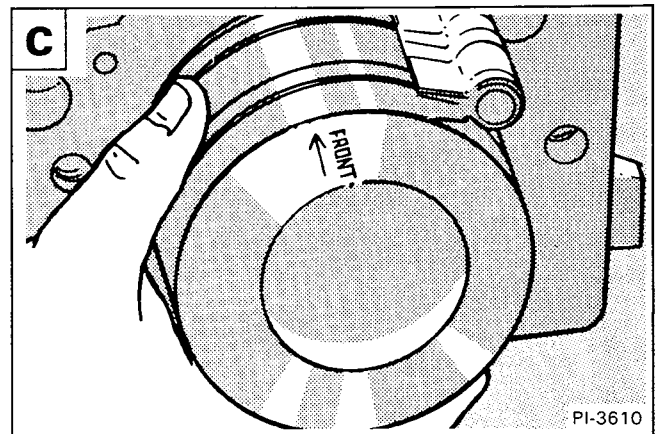

Carefully push the piston and connecting rod assembly into the bore while guiding the rod bearing over the crankshaft journal **D**.

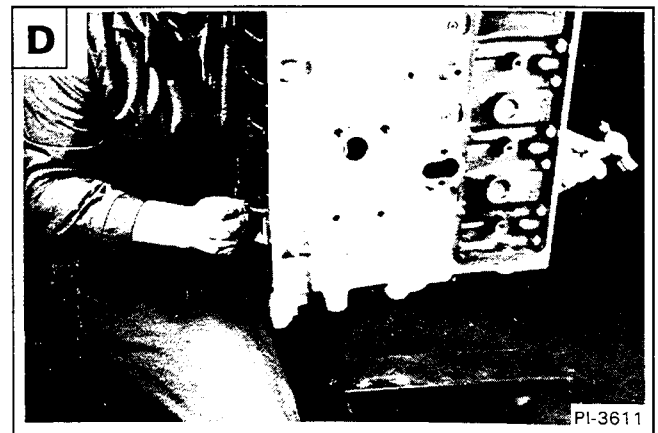

CYLINDER BLOCK (Cont'd)

Drive the expansion plug out of the camshaft bore **A**.

Do not damage the camshaft bore.

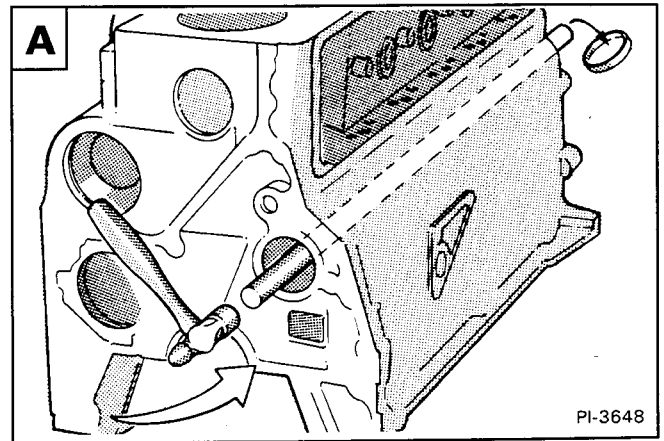

Drive the bushing from the cylinder block bore **B**.

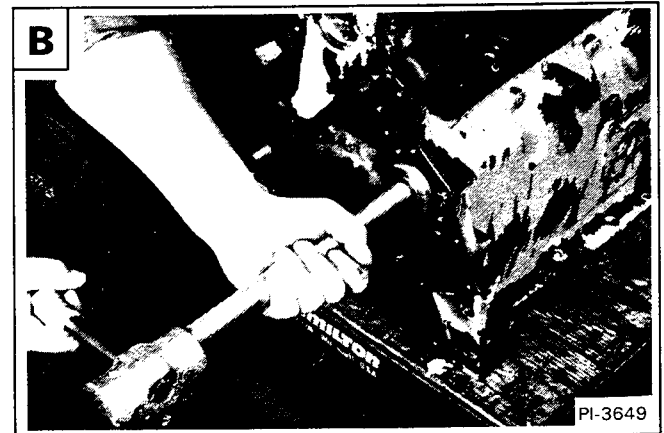

Mark the cam bushing and block for correct alignment **C**.

Install the cam bushing flush with the block **B**.

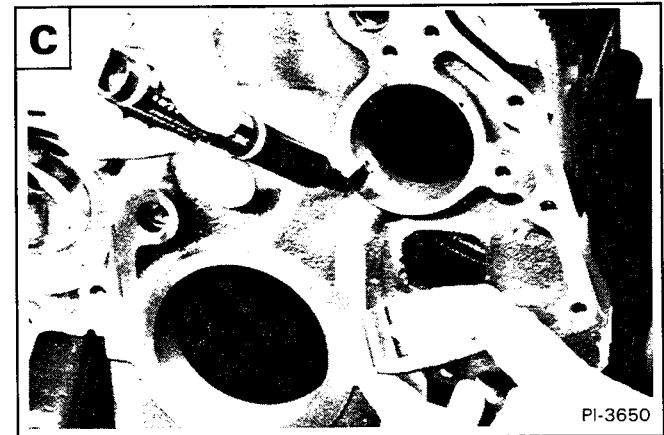

Check to make sure the oil hole passage is in alignment **D**.



CAMSHAFT AND GEAR (Cont'd)

Remove the valve tappets **A**.

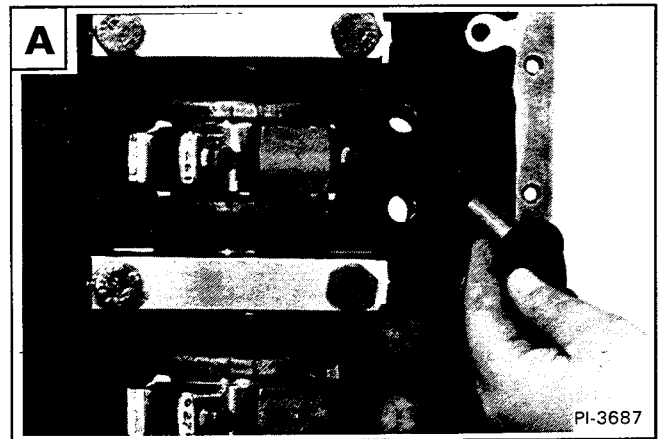

Inspection

Clean the camshaft and gear in solvent. Dry with compressed air.

Inspect the lift pump lobe and bearing journals for pitting or scoring **B**.

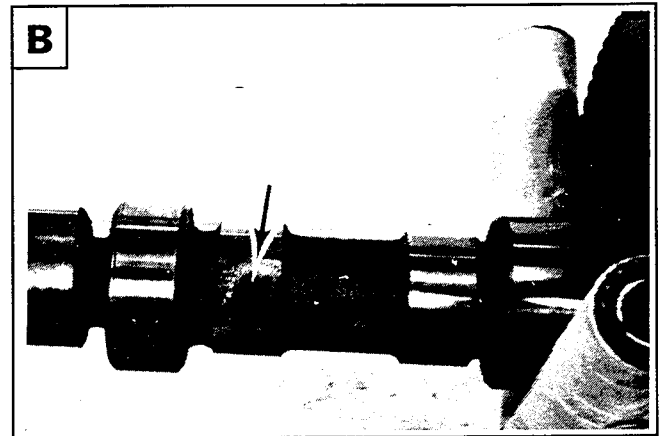

Measure the bearing journals and valve lobes **C**.

The standard diameter for the journals is 2.125-2.127" (53,98-54,03 mm).

The standard height of the intake valve lobes is 1.861-1.866" (47,27-47,40 mm).

The standard height of the exhaust valve lobes is 1.850-1.855" (46,99-47,12 mm).

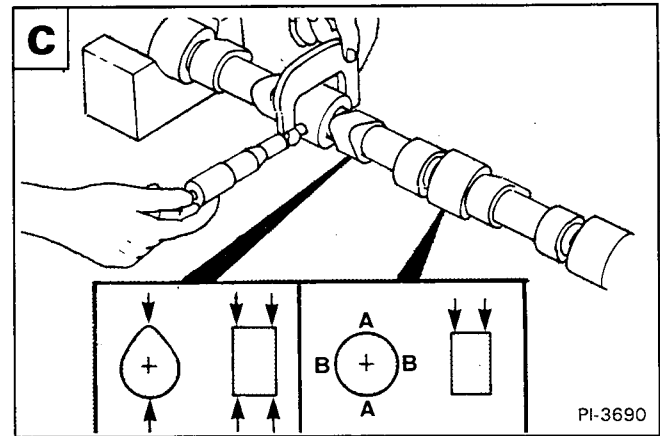

A single pit should not be greater than the area of a 0.08" (2,0 mm) diameter **D**.

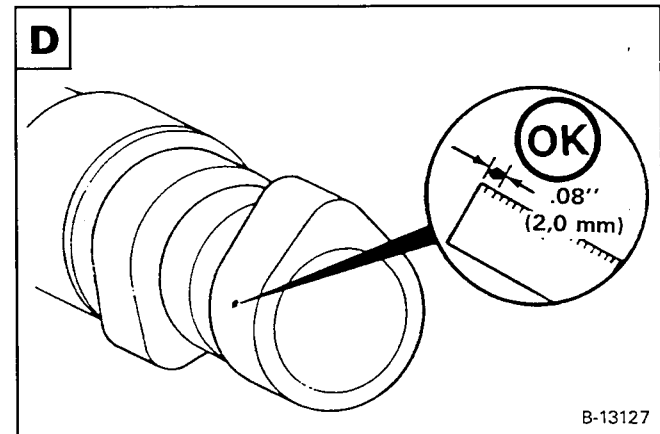

OIL PUMP (Cont'd)

Removal

Remove the bolts at the oil pump **A**.

Remove the oil pump assembly.

Remove the oil pump idler gear assembly **A**.

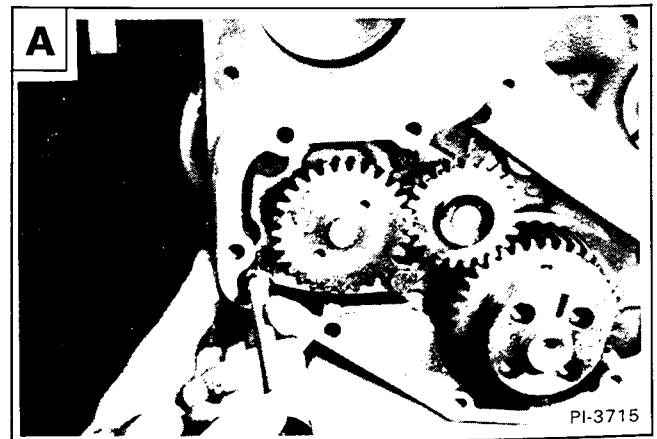

Inspection

Remove the sealing plate **B**.

Mark "top" on the gerotor planetary.

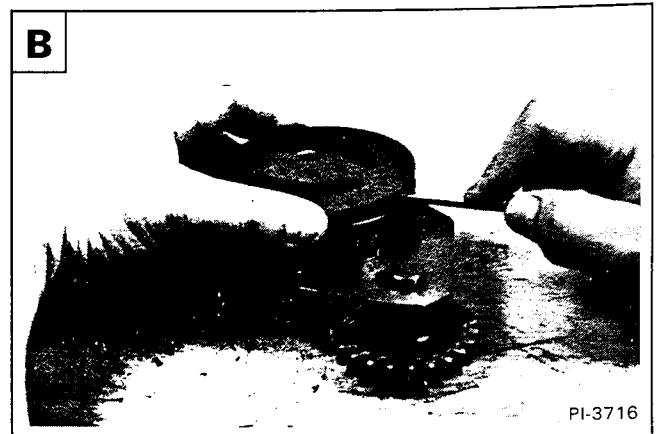

Remove the gerotor planetary **C**.

Inspect for wear, scoring or cracks at the gears and gerotor planetary.





WARNING

Wear safety glasses to prevent eye injury when any of the following conditions exist:

- When fluids are under pressure.
- Flying debris or loose material is present.
- Engine is running.
- Tools are being used.

W-2019-1285



Clean all parts in solvent. Blow dry with compressed air.

Install the gerotor planetary in its original position.

Measure the tip clearance **D**.

Maximum clearance is 0.007" (0,178 mm).

WATER PUMP

Removal and Installation

Remove the radiator (See Page 7-37).

Remove the water pump bolts **A**.

Installation: Tighten the bolts to 18 ft.-lbs. (24 Nm) torque.

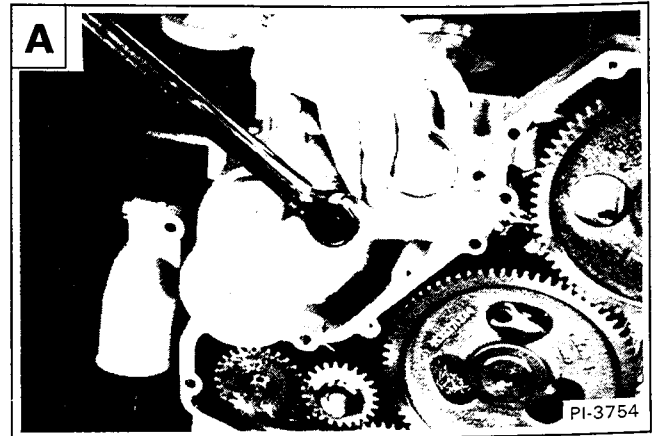

Remove the water pump and O-ring **B**.

Installation: Always use a new O-ring when installing the water pump.

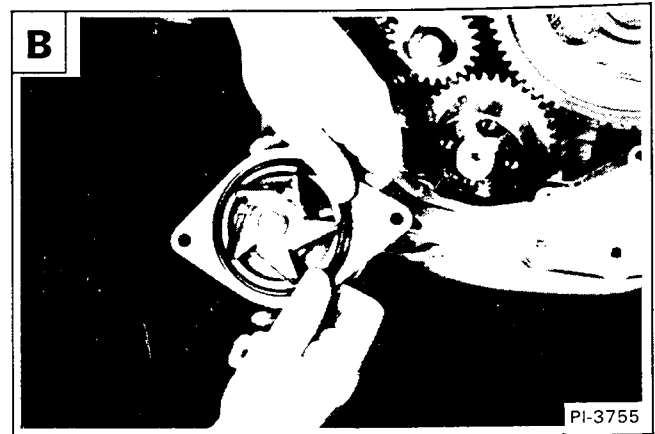

Inspection

Inspect the impeller blades for wear or corrosion.

Inspect for free rotation of the water pump **C**.

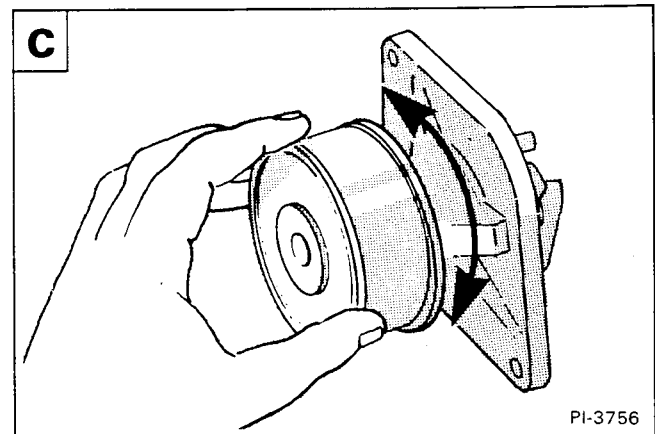

Check the weep hole for leakage **D**.

Replace the water pump if any of its components do not operate correctly or show signs of wear, damage or leakage.

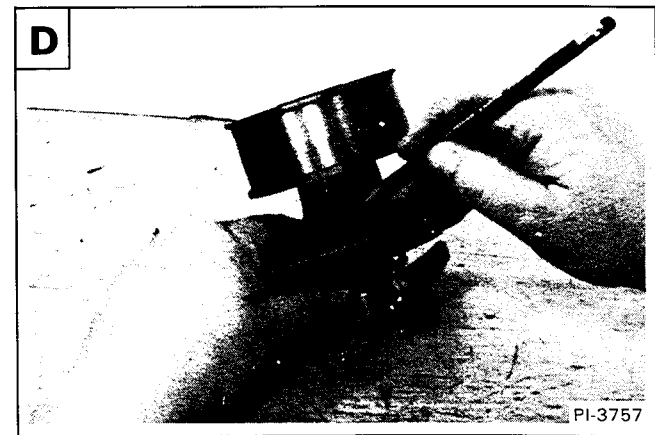

BALANCER (Cont'd)

Apply a coat of Loctite 609 to the bearing surface of the shaft **A**.

Slide a new inner race into position on the shaft.

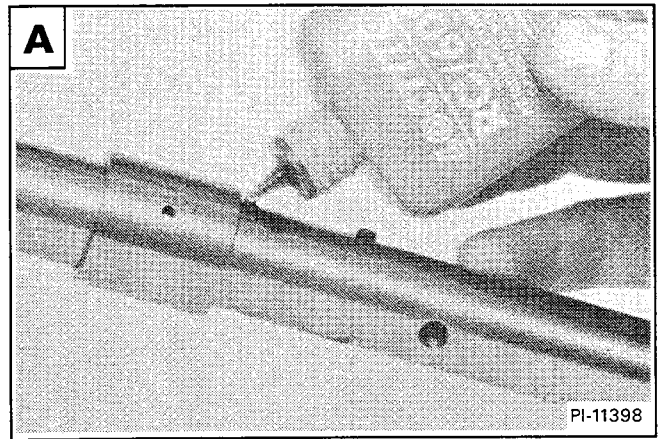

Remove the excess Loctite from the shaft **B**.

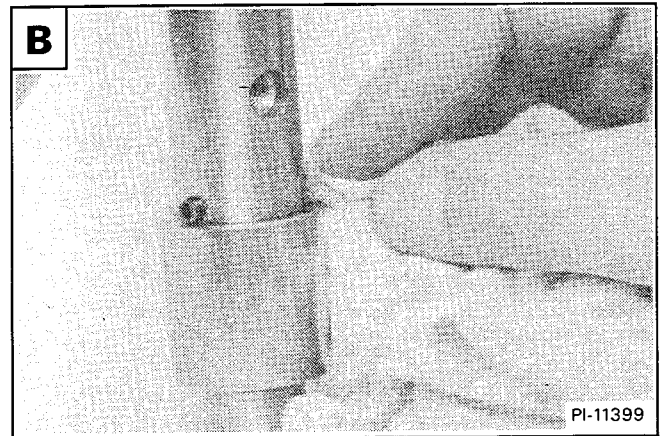

Install the three remaining roll pins **C**.

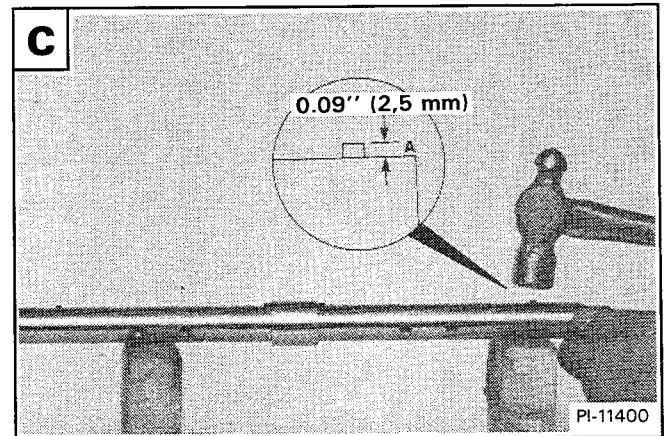

Apply a coat of Loctite 609 to the bearing surface **D**.

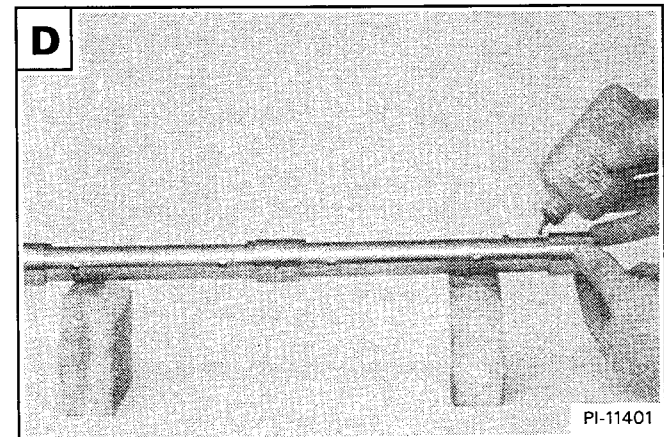

TECHNICAL DATA

	Page Number
DECIMAL AND MILLIMETER EQUIVALENTS	
Chart	8-8
ENGINE SPECIFICATIONS	
Blowby Conversion Chart.....	8-7
Blowby Measurement.....	8-7
Camshaft	8-4
Connecting Rod.....	8-3
Crankshaft	8-4
Cylinder Head.....	8-3
Engine Block.....	8-4
Engine Torque.....	8-6
Exhaust Manifold.....	8-4
Fuel Injection Pump.....	8-4
Fuel Injectors.....	8-4
Piston.....	8-3
Oil Cooler.....	8-5
Oil Pump.....	8-5
Rocker Arms.....	8-3
Tappet	8-3
Thermostat	8-5
Turbocharger.....	8-4
Valves	8-3
HYDRAULIC/HYDROSTATIC FLUID SPECIFICATIONS	
Specifications	8-7
LOADER SPECIFICATIONS	
Capacities	8-2
Drive System.....	8-2
Electrical.....	8-2
Engine.....	8-1
Loader Hydraulics.....	8-2
Operation and Performance.....	8-1
Tires	8-2
STANDARD TORQUE SPECIFICATIONS FOR BOLTS	
Chart	8-9
U.S. TO METRIC CONVERSION	
Chart	8-8

**TECHNICAL
DATA**

CLICK HERE TO **DOWNLOAD** THE COMPLETE MANUAL

- Thank you very much for reading the preview of the manual.
- You can download the complete manual from: www.heydownloads.com by clicking the link below



- Please note: If there is no response to CLICKING the link, please download this PDF first and then click on it.

CLICK HERE TO **DOWNLOAD** THE COMPLETE MANUAL