

963

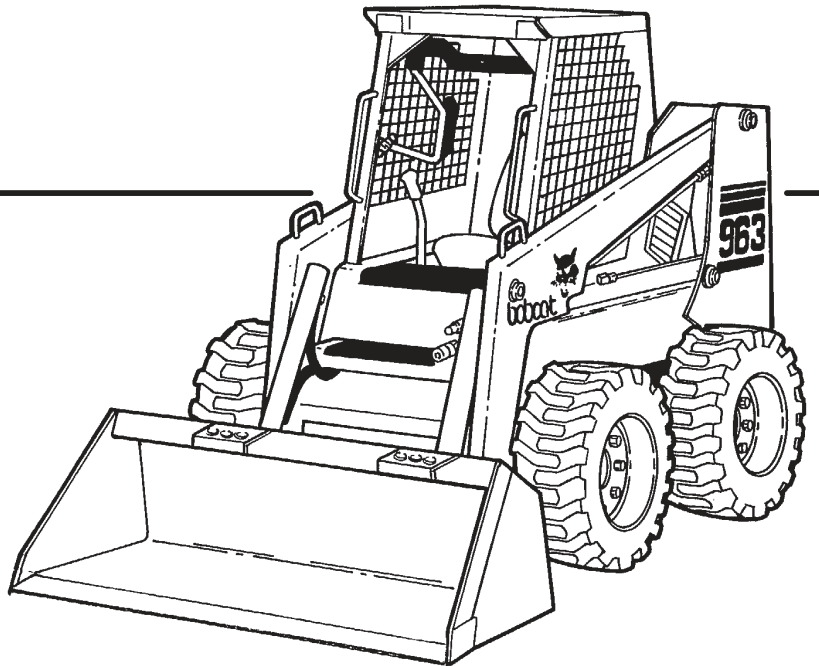

Service Manual



Dealer Copy — Not for Resale

Doosan purchased Bobcat Company from Ingersoll-Rand Company in 2007. Any reference to Ingersoll-Rand Company or use of trademarks, service marks, logos, or other proprietary identifying marks belonging to Ingersoll-Rand Company in this manual is historical or nominative in nature, and is not meant to suggest a current affiliation between Ingersoll-Rand Company and Bobcat Company or the products of either.

**EQUIPPED WITH
BOBCAT INTERLOCK
CONTROL SYSTEM (BICS™)**

1 of 502

**MELROE
INGERSOLL-RAND**

6724545 (6-12)

Printed in U.S.A.



© Melroe Company 1997

CLICK HERE TO **DOWNLOAD** THE COMPLETE MANUAL

- Thank you very much for reading the preview of the manual.
- You can download the complete manual from: www.heydownloads.com by clicking the link below



- Please note: If there is no response to **CLICKING** the link, please download this PDF first and then click on it.

CLICK HERE TO **DOWNLOAD** THE COMPLETE MANUAL

SAFETY INSTRUCTIONS

WARNING

Instructions are necessary before operating or servicing machine. Read and understand the Operation & Maintenance Manual, Handbook and signs (decals) on machine. Follow warnings and instructions in the manuals when making repairs, adjustments or servicing. Check for correct function after adjustments, repairs or service. Untrained operators and failure to follow instructions can cause injury or death.

W-2003-0299

The following publications provide information on the safe use and maintenance of the loader and attachments:

- The Delivery Report is used to assure that complete instructions have been given to the new owner and that the machine is in safe operating condition.
- The Operation & Maintenance Manual delivered with the loader gives operating information as well as routine maintenance and service procedures. It is a part of the loader and must stay with the machine when sold. Replacement Operation & Maintenance Manuals can be ordered from your Bobcat loader dealer.
- The loader has machine signs (decals) which instruct on the safe operation and care. The signs and their locations are shown in the Operation & Maintenance Manual. Replacement signs are available from your Bobcat loader dealer.
- The loader has a plastic Operator's Handbook fastened to the operator cab. Its brief instructions are convenient to the operator. The Handbook is available from your dealer in an English edition or one of many other languages. See your Bobcat dealer for more information on translated versions.
- The EMI Safety Manual (available in Spanish) delivered with the loader gives general safety information.
- The Service Manual and Parts Manual are available from your dealer for use by mechanics to do shop-type service and repair work.
- The Skid-Steer Loader Operator Training Course is available through your local dealer. This course is intended to provide rules and practices for correct operation of the Bobcat loader. The course is available in English and Spanish version.
- The Service Safety Training Course is available from your Bobcat dealer. This course provides information for safe and correct service procedures for Bobcat Skid-Steer loaders.
- The Bobcat Skid-Steer Loader Safety Video is available from your Bobcat Dealer.

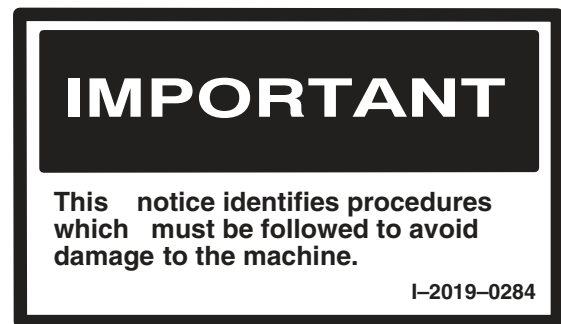

Safety Alert Symbol: This symbol with a warning statement, means: "Warning, be alert! Your safety is involved!" Carefully read the message that follows.

LIFT ARM SUPPORT DEVICE



WARNING

Never work on a machine with the lift arms up unless the lift arms are secured by a lift arm support device. Failure to use an approved lift arm support device can allow the lift arms or attachment to fall and cause injury or death.

W-2059-0991

Engaging The Lift Arm Support Device

Maintenance and service work can be done with the lift arms lowered.

If the lift arms must be raised for service, use the following procedure:

Disconnect the spring (Item 1) [A] from the lift arm support device retaining pin (Item 2) [A]. Hold the support device and remove the retaining pin.

Lower the lift arm support device on top of the lift cylinder. Hook the free end of the spring (Item 1) [B] to the lift arm support device so there will be no interference with the support device engagement.

With the operator in the seat, seat belt fastened and seat bar lowered, start the engine.

Raise the lift arms, until the lift arm support device lowers onto the lift cylinder rod [C].

Lower the lift arms slowly until the support device is held between the lift arm and the lift cylinder. Stop the engine. Raise the seat bar and move foot pedals until both pedals lock.

Install the pin (Item 1) [D] into the rear of the lift arm support device below the cylinder rod.



WARNING

Service lift arm support device if damaged or if parts are missing. Using a damaged lift arm support or with missing parts can cause lift arms to drop causing injury or death.

W-2271-1197

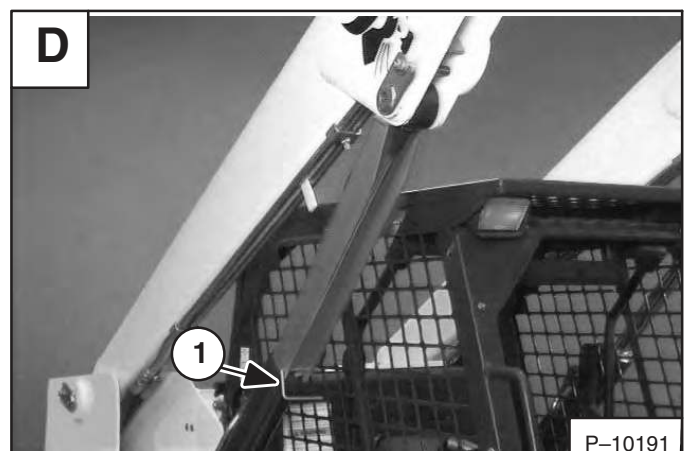
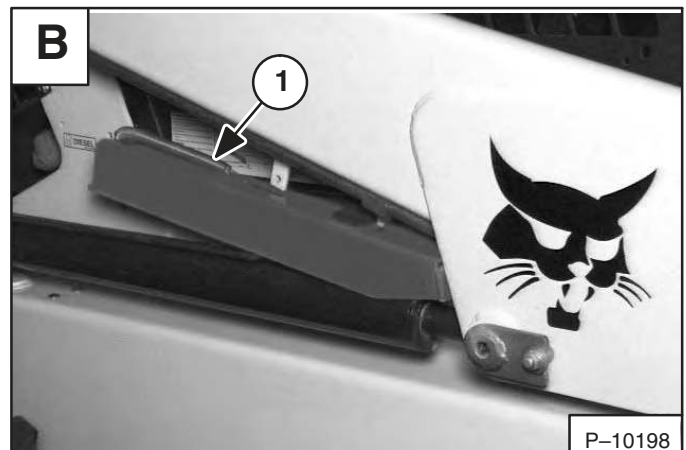
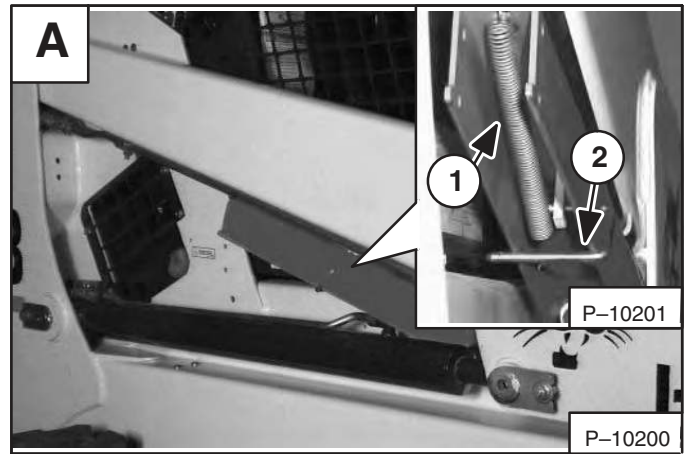

ENGINE LUBRICATION SYSTEM

Checking Engine Oil

Check the engine oil level every day before starting the engine for the work shift.

Open the rear door. Remove the dipstick (Item 1) [A].

Keep the oil level between the marks on the dipstick[B].

Use a good quality motor oil that meets API Service Classification of CD, or better.

RECOMMENDED SAE VISCOSITY NUMBER

(LUBRICATION OILS FOR DIESEL ENGINE CRANKCASE)

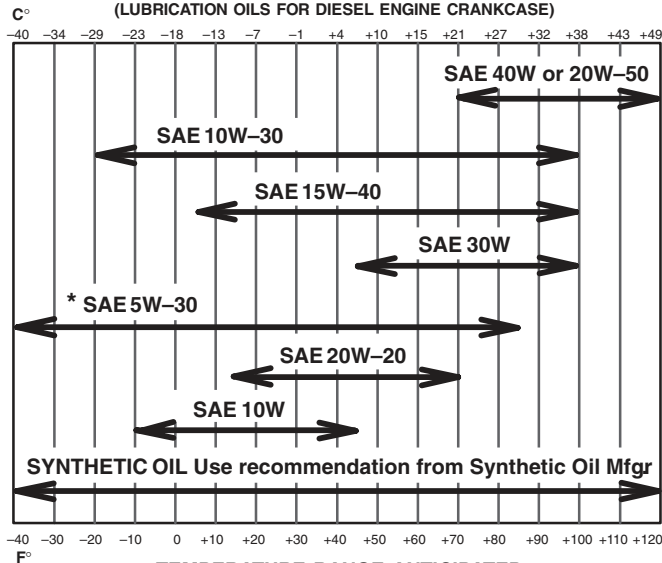

* Can be used **ONLY** when available with appropriate diesel rating.

Replacing The Oil And Filter

See the *SERVICE SCHEDULE* Page 1-3 for the service interval for replacing the engine oil and filter.

Run the engine until it is at operating temperature. Stop the engine.

Open the rear door. Remove the drain hose (Item 1) [C] from the storage position. Remove the drain plug from the end of the hose. Drain the oil into a container.

Remove the oil filter (Item 2) [C].

Clean the filter housing surface. Put clean oil on the new oil filter gasket. Install the new filter and hand tighten.

Install and tighten the drain plug.

Remove the filler cap (Item 2) [A].

Fill the engine crankcase with oil of the correct grade and viscosity. (See Oil Chart above.) Capacity is 9 qts. (8,5 L.)

Start the engine and let it run for several minutes.

Stop the engine.

Check for leaks at the oil filter and check the oil level.

Add oil as needed if it is not at the top mark on the dipstick

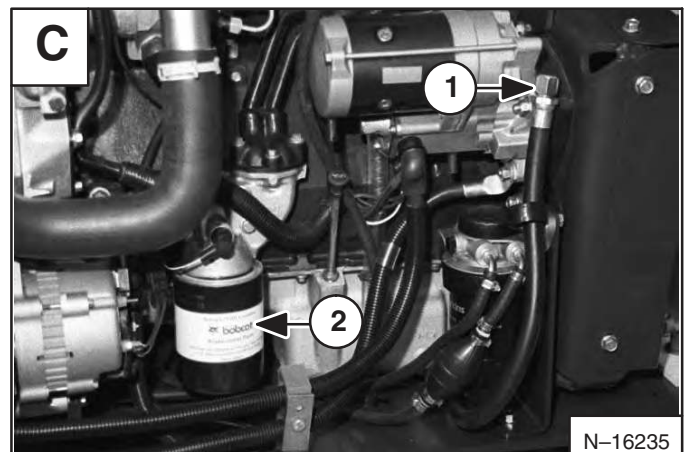
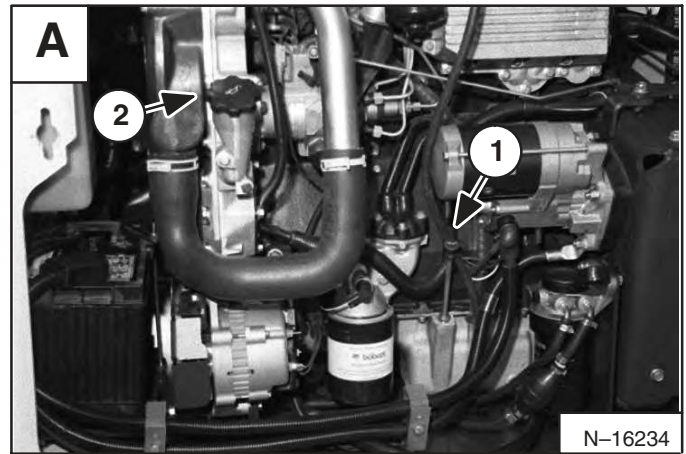

! WARNING

Always clean up spilled fuel or oil. Keep heat, flames, sparks or lighted tobacco away from fuel and oil. Failure to use care around combustibles can cause explosion or fire which can result in injury or death.

W-2103-1285

LUBRICATING THE LOADER (Cont'd)

Procedure (Cont'd)

5. Rod End Tilt Cylinder (Both sides) [A].
6. Bob-Tach Wedge (Both Sides) [A]

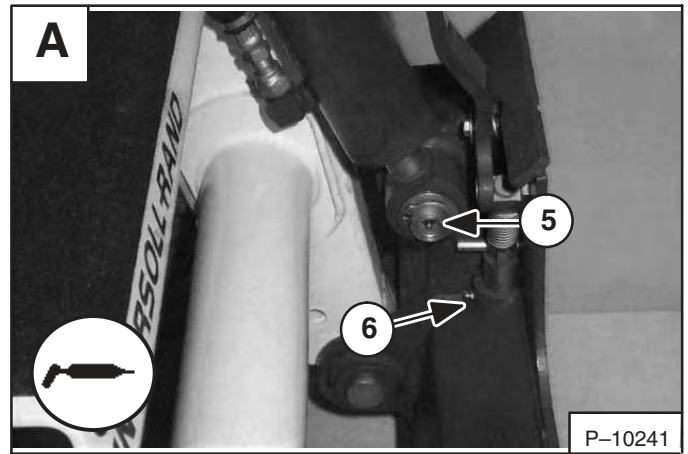

7. Bob-Tach Pivot Pin (Both Sides) [B].

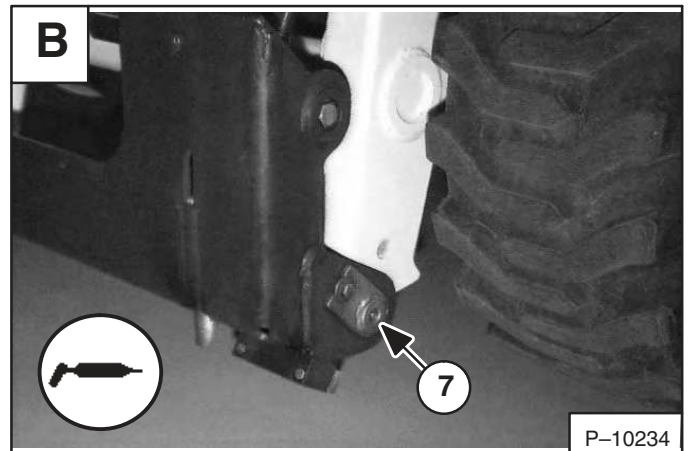

Every 250 Hours:

Add grease to the fittings (Item 1) [C].

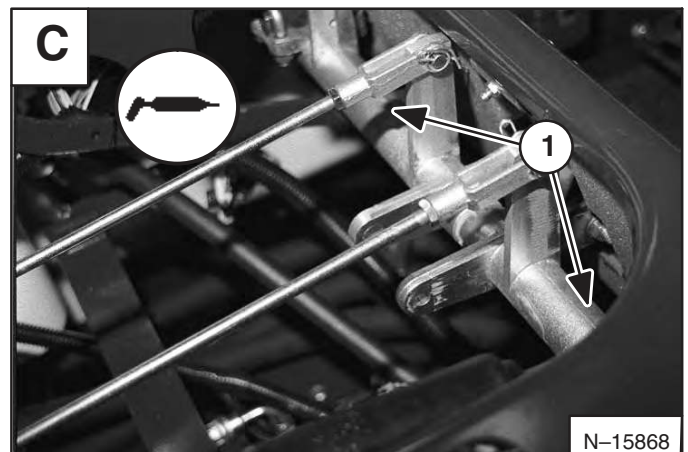

TILT CYLINDER (Cont'd)

Checking Tilt Cylinder(s) (Cont'd)

Left Side (Cont'd)

Install a cap (Item 1) [A] on the hydraulic hose and tighten.

Engage the parking brake. Lower the seat bar. Start the engine and push the bottom (heel) of the tiltpedal. If there is leakage from the open port, remove the tilt cylinder for repair.

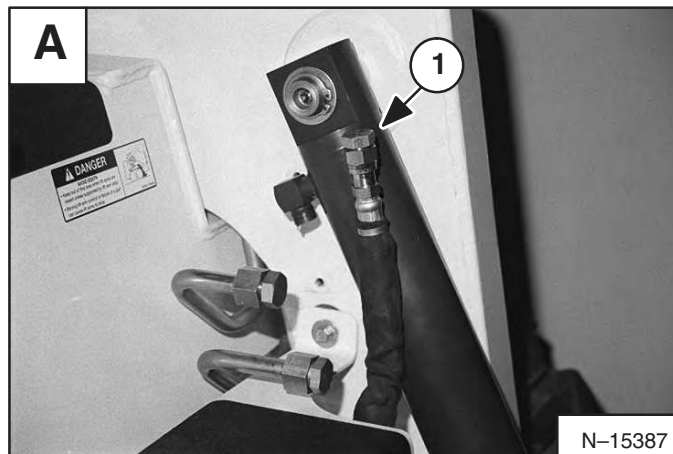

Removal And Installation

Put the Bob-Tach on the floor [B]. Stop the engine.

Remove the snap ring and washer at the rod end of the tilt cylinder (Item 1) [B].

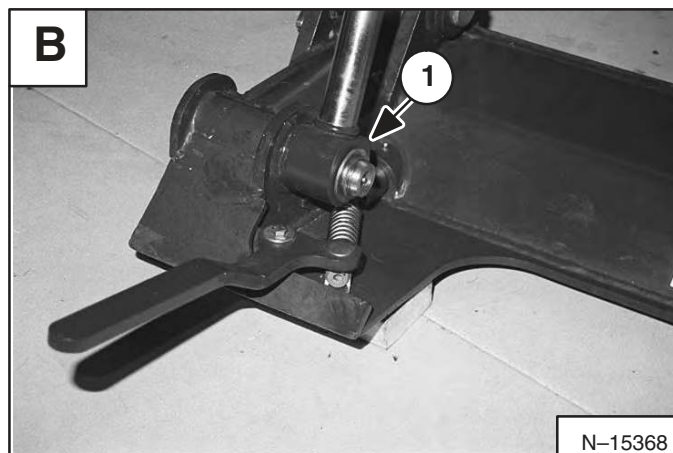

Right Side

Mark the hoses for correct installation.

Disconnect both hoses (Item 1) [C] at the tilt cylinder.

Put plugs in the ends of the hoses.

Remove the snap ring and washer from the pivot pin (Item 2) [C].

Remove the tilt cylinder by sliding off the pivot pins.



TILT JUNCTION BLOCK

Removal And Installation

Remove any attachment from the Bob-Tach. Roll the Bob-Tach fully out.

Stop the engine.

Use a floor jack and raise the lift arms.

Install jackstands (Item 1) [A] under the lift arms.

Pull up on the lift arm by-pass control and move the lift pedal to release the hydraulic pressure.

Remove the tilt junction block mounting bolts (Item 1) [B].

Left Side

Disconnect the tubelines (Item 1) [C] from the front hydraulic couplers.

Remove the mounting bolts (Item 2) [C] and remove the mounting bracket and hydraulic couplers.

Remove the front step mounting bolts (Item 3) [C].

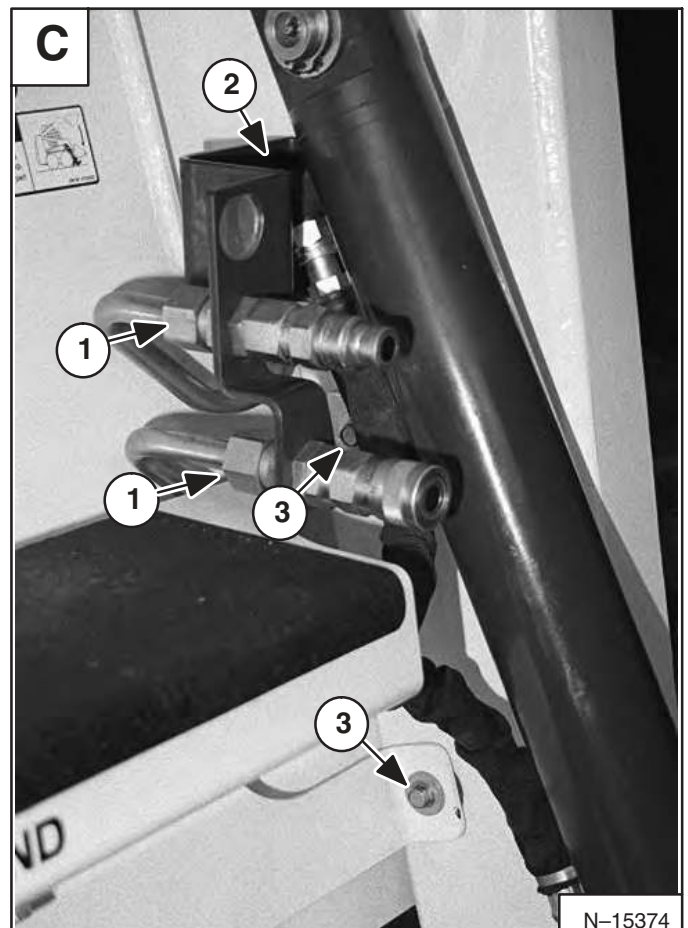
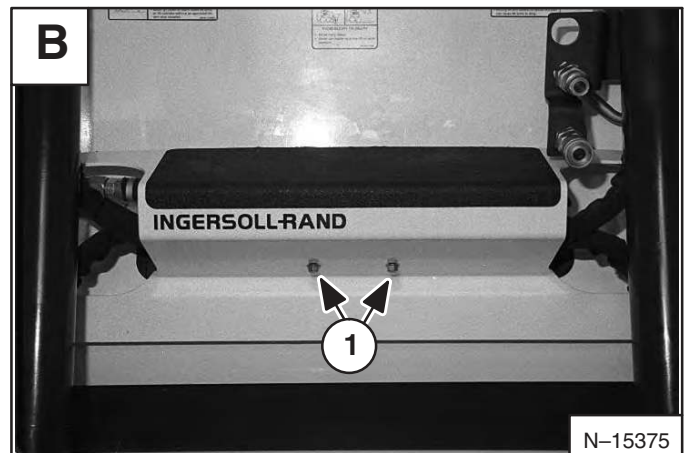
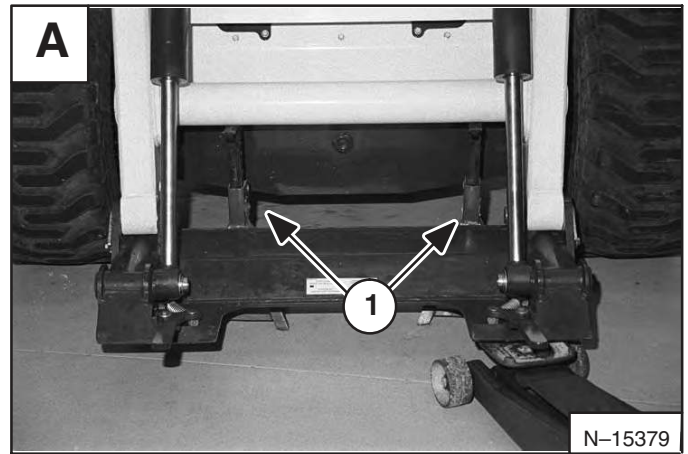

BICS™ VALVE (Cont'd)

Check Valve

Loosen and remove the check valve (Item 1) [A].

Installation: Tighten the check valve to 20 ft.-lbs. (27 Nm) torque.

Inspect and clean the screen (Item 1) [B] on the end of the check valve.

Inspect the check valve for damage. Replace the O-rings and back-up washers before installation.

Replace the check valve if necessary.

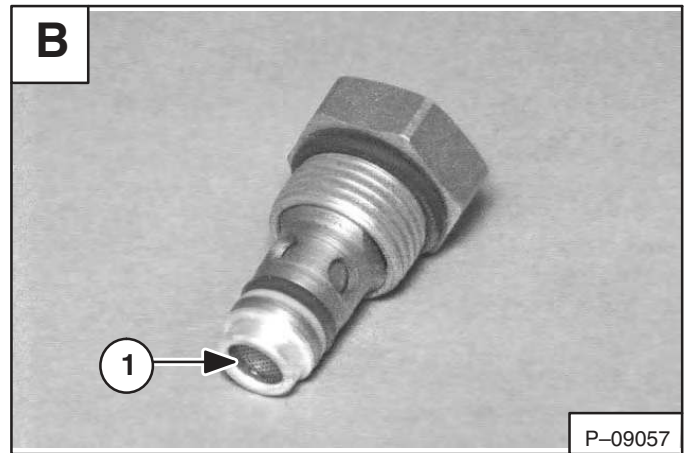
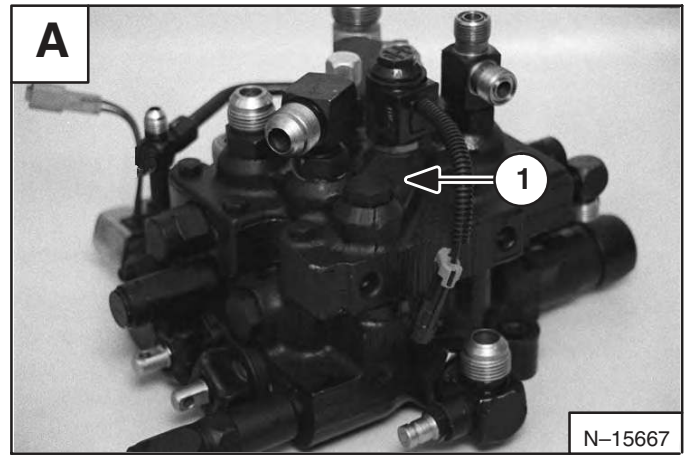

HYDRAULIC CONTROL VALVE (Cont'd)

Anti-Cavitation Valve

Remove the anti-cavitation valve (Item 1) [A] from the control valve for the lift section.

Installation: Tighten anti-cavitation valve to 35–40 ft.-lbs. (47–54 Nm) torque.

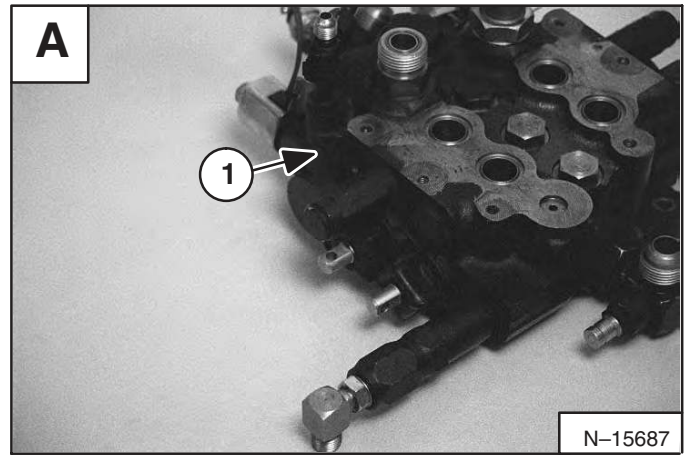

Remove the anti-cavitation valve (Item 1) [B] from the control for the lift section.

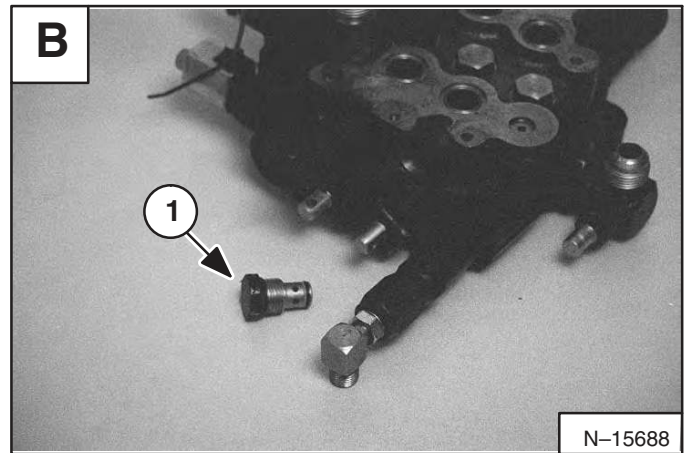

Remove the O-rings and back-up washer from the anti-cavitation valve [C].

Installation: Always use new O-rings and back-up washers.

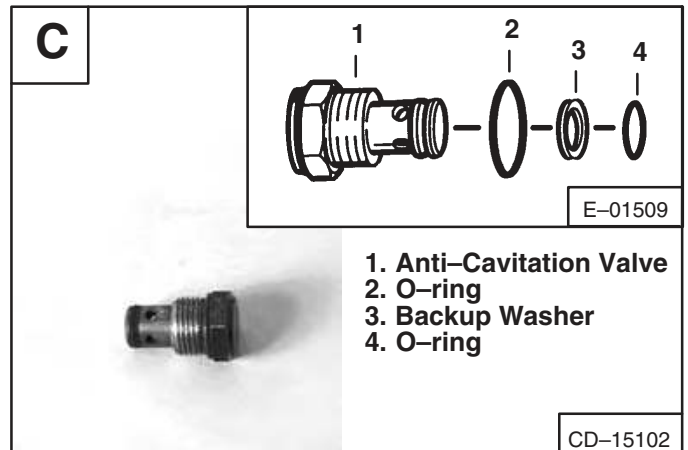

HYDRAULIC CONTROL VALVE (Cont'd)

H-Port – Auxiliary Section

Loosen the plug (Item 1) [A].

Installation: Tighten the plug to 35–40 ft.-lbs. (47–54 Nm) torque.

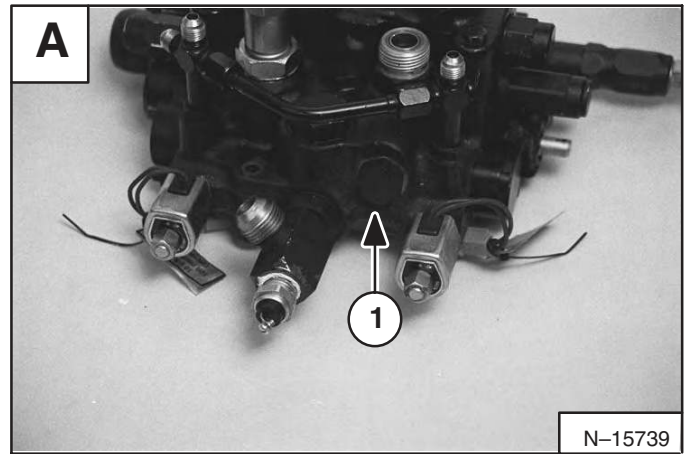

Remove the plug from the control valve [B].

Replace the O-ring.

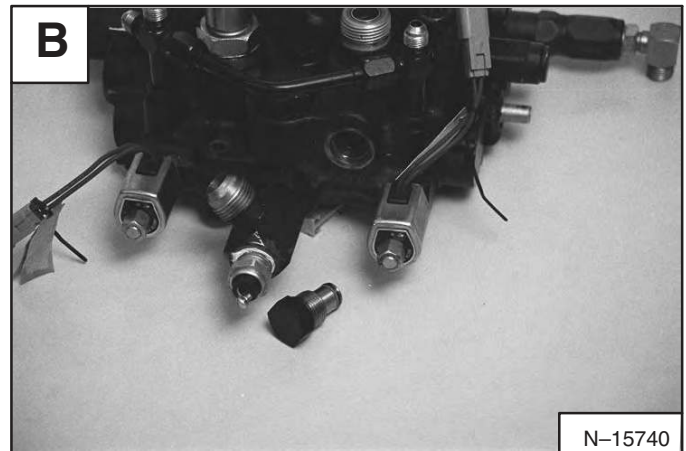

Depending on the application of the auxiliaries, the control valve may be equipped with a port relief valve (Item [C] (H port).

Remove the port relief valve (Item 1) [D].

Installation: Replace the O-rings and back-up washers. Tighten the port relief valve to 35–40 ft.-lbs. (47–54 Nm) torque.

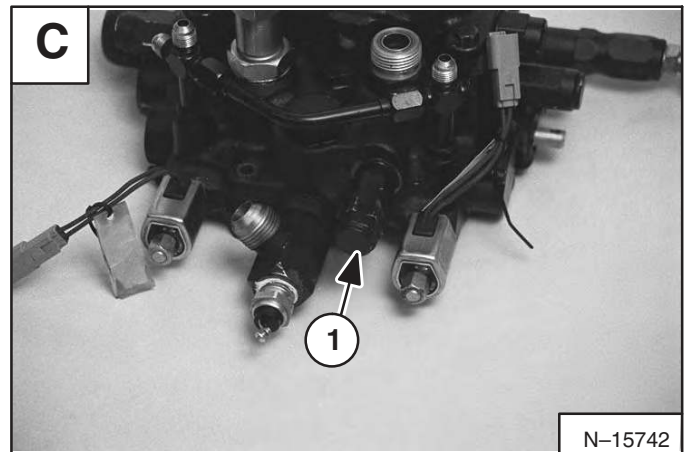

Inspection

Check the spools for wear or scratches.

Check that the spools are not loose in their bore.

Check that the centering springs are not broken.

Check that the load check valve seats are not worn.

Check the load check poppets for damage.

Check the rubber boots and retainers that they are not worn or damaged.

Replace the parts as needed.

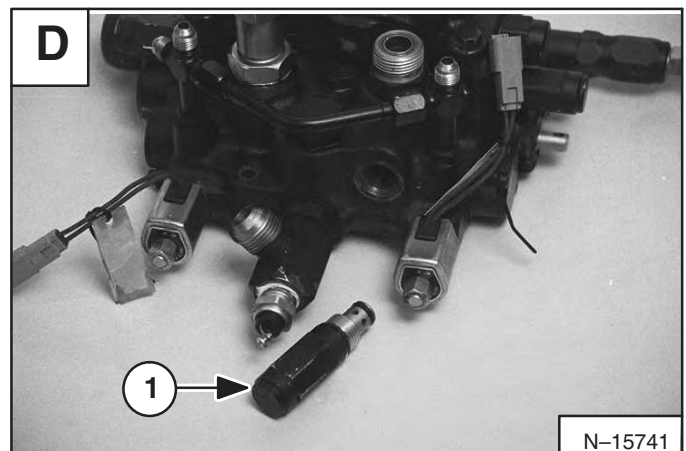

HYDRAULIC PUMP (Cont'd)

Disassembly And Assembly (Cont'd)

Remove the end housing (Item 1) [A].

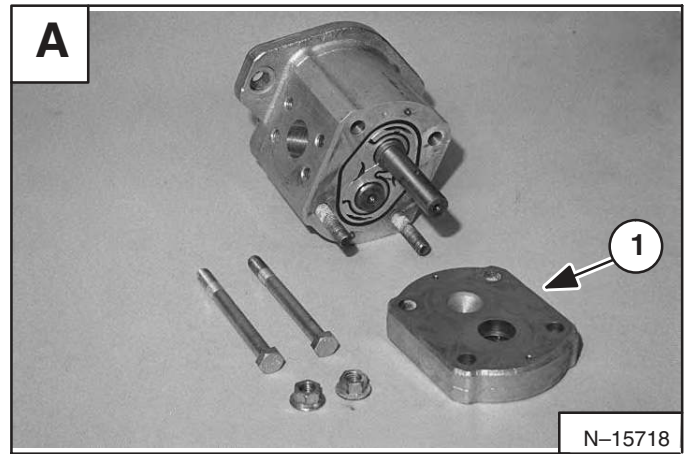

Remove the bearing housing (Item 1) [B].

Remove the back-up seal/O-ring seal (Item 2) [B] from the bearing housing.

Remove the large O-ring (Item 3) [B] from the pump housing.

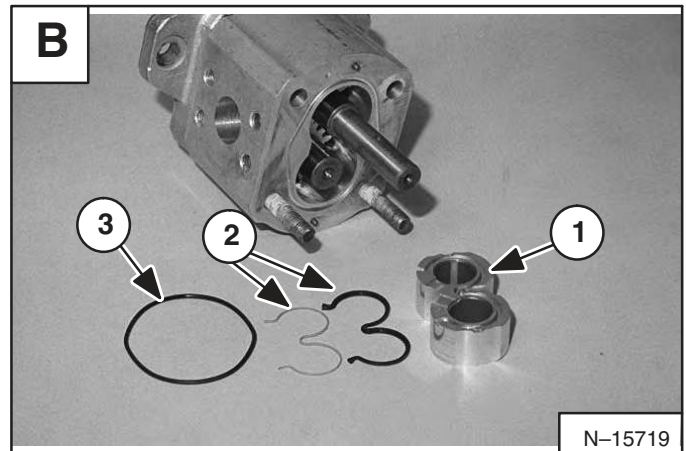

Assembly: The O-ring and back-up washer (Item 1)[C] must be installed toward the pressure side of the pump.

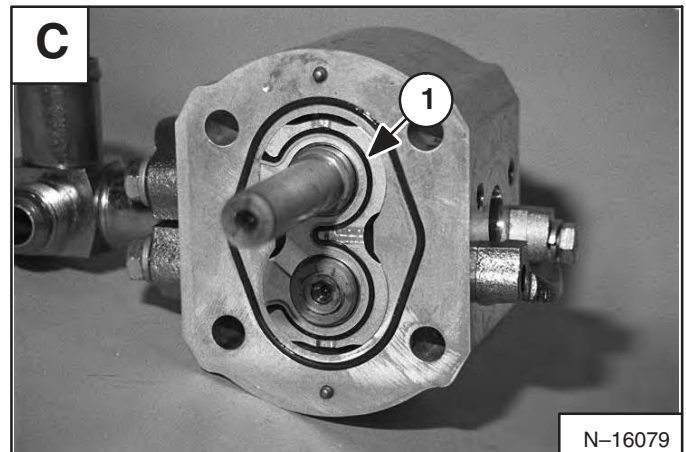

Remove the drive end housing (Item 1) [D].

Remove the large O-ring (Item 2) [D] from the pump housing.

Remove the bearing housing (Item 3) [D].

Remove the back-up seal/O-ring seal (Item 4) [D] from the bearing housing.

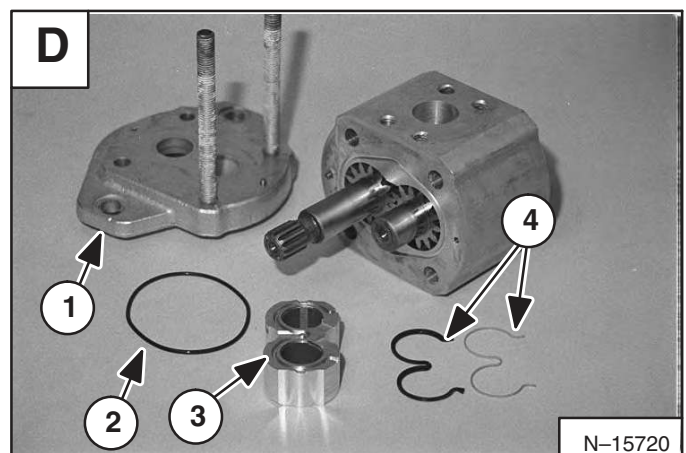

CONTROL PEDALS MOUNTING PANEL (Cont'd)

Removal and Installation (Cont'd)

Remove the right side interlock shield mounting nuts (Item 1) [A].

Installation: Tighten the shield mounting nuts to 25–28 ft.-lbs. (34–38 Nm) torque.

Remove the interlock shield (Item 2) [A].

Remove the right side mounting bolts (Item 3) [A].

Remove the right side panel.

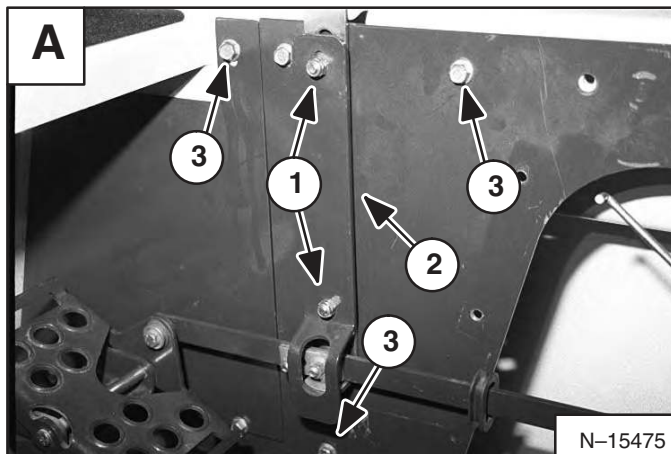

Remove the mounting bolt (Item 1) [B] from the left front side panel (Item 2) [B].

Remove the left front panel. (Repeat the procedure for right side panel.)

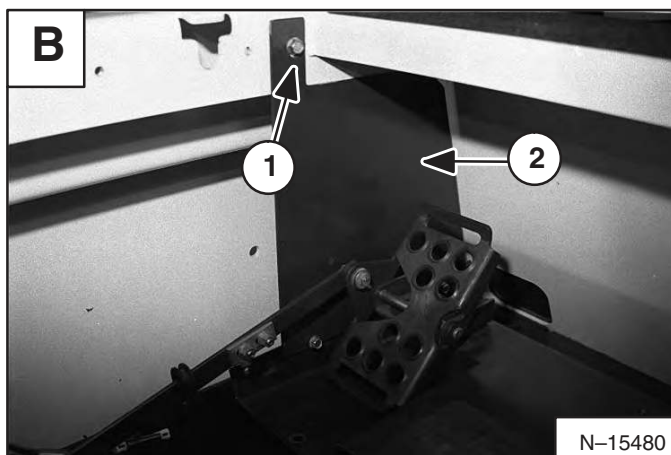

Remove the mounting bolts (Item 1) [C] from the control pedals mounting panel.

Remove the control pedal mounting panel from the loader.

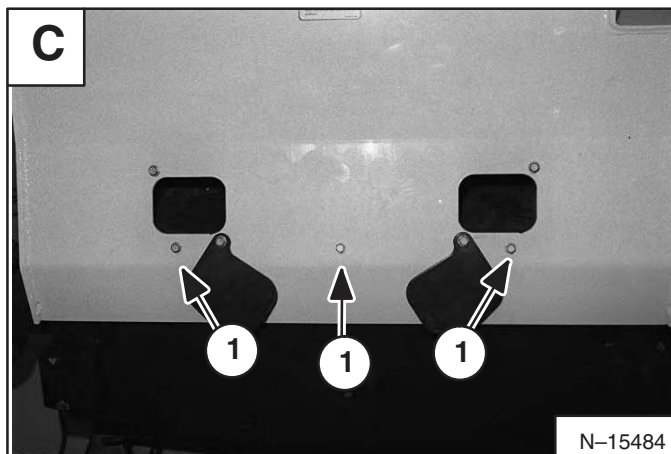

STEERING LEVERS (Cont'd)

Disassembly And Assembly (Cont'd)

Remove the steering cross shaft mounting bolts (Item 1) [A] (both sides).

Installation: Tighten the mounting bolts to 15–17 ft.-lbs. (21–23 Nm) torque.

Remove the steering cross shaft from the control panel. Disassemble the right and left steering shaft from the cross shaft.

Assembly: Install new nylon bushings (Item 1) [B] as needed at the ends of the steering shaft. Be sure to apply grease to the cross shaft before installing the right and left steering shaft.

Assembly: Check the nylon bushings (Item 1) [C] and replace as needed. Make sure the wave washer (Item 2) [B] is between the nylon bushings.

Check and replace the cams (Item 3) [C] if worn or damaged. Tighten the cam jam nuts, the cams must not rotate on the mounting bolt.

Remove the bolts and nuts (Item 1) [D] if the neutral centering bracket needs to be replaced.

Assembly: If the neutral centering bracket is replaced, keep the bracket vertical to be sure that the both cams make full contact in the pocket of the detent bracket.

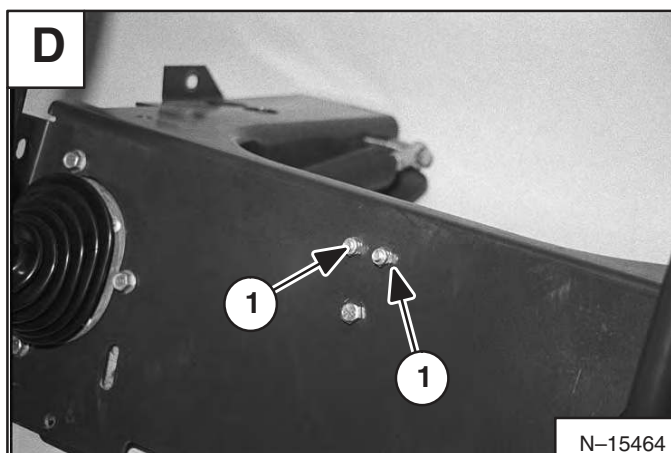
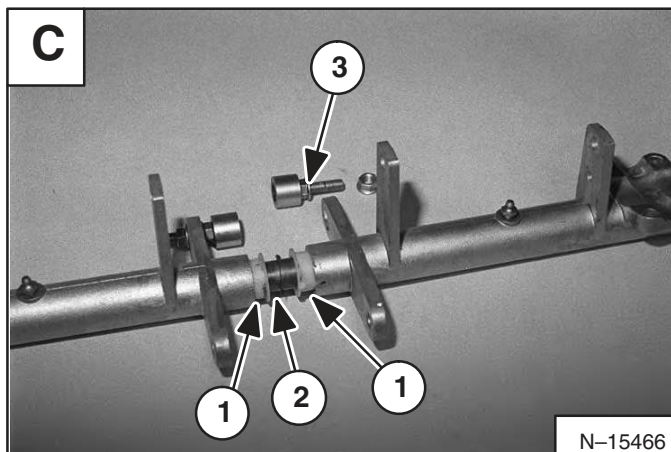
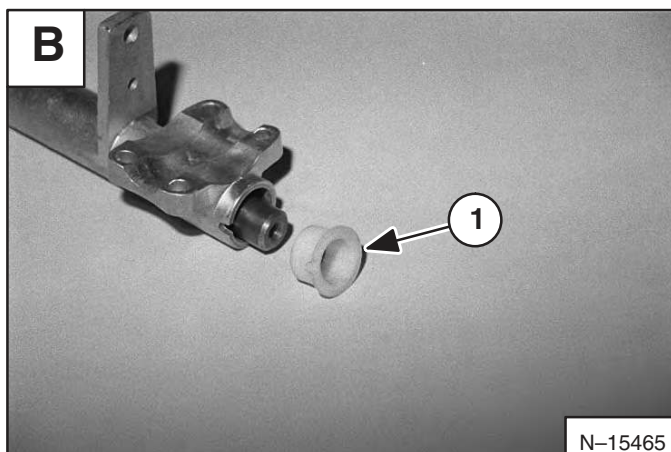
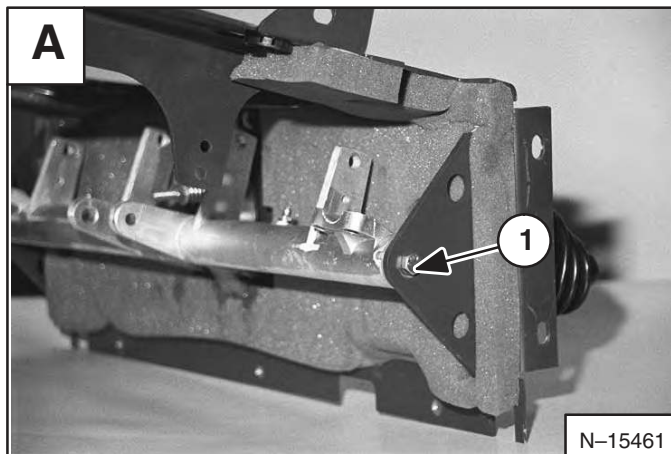

HYDROSTATIC CONTROLLER (Cont'd)

Disassembly and Assembly (Cont'd)

Disassemble the following parts, check for wear and replace as needed [A]:

Item	Description
1	GUIDE
2	PLUNGER
3	SPOOL/SPRING ASSEMBLY
4	RETURN SPRING

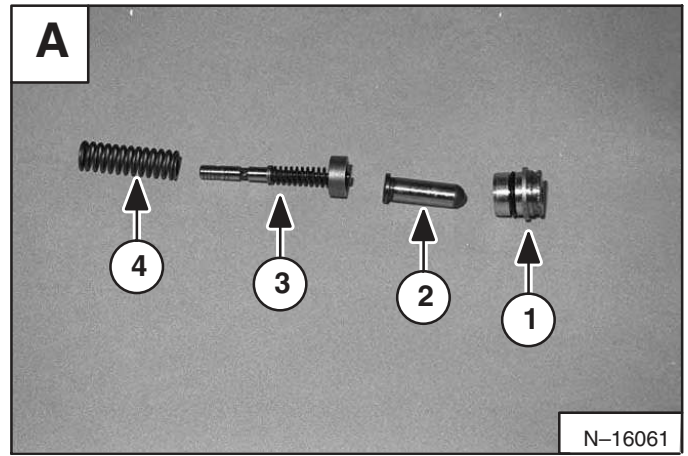

Remove the locking discs (Item 1) [B] and disassemble the following parts, check for wear and replace as needed [B]:

Item	Description
1	LOCKING DISC
2	SPRING GUIDE
3	CONTROL SPRING
4	SHIMS
5	SPOOL

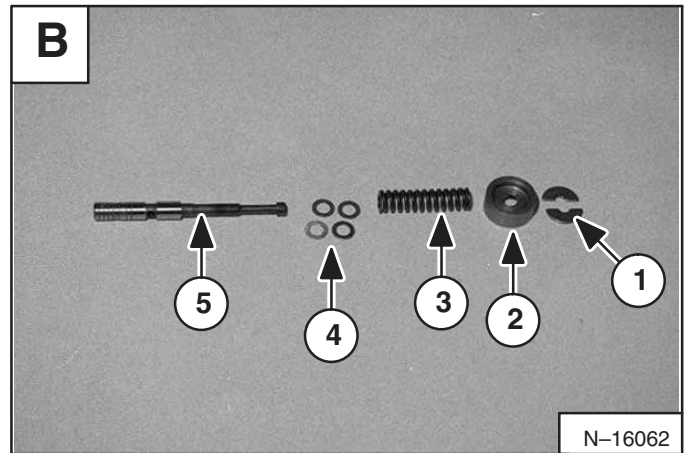

Adjustment

After the hydrostatic controller is assembled, you should feel free play between the set screws (Item 1) [C] and top of the plunger.

If not, loosen the lock nut (Item 2) [C] first, then loosen the set screw (Item 1) [C] until a small amount of free play can be felt between the plunger and set screw. If there is no free play, steering lever neutral can not be obtained.

NOTE: Be careful when turning the set screws, they will break if the lock nut is not loose.

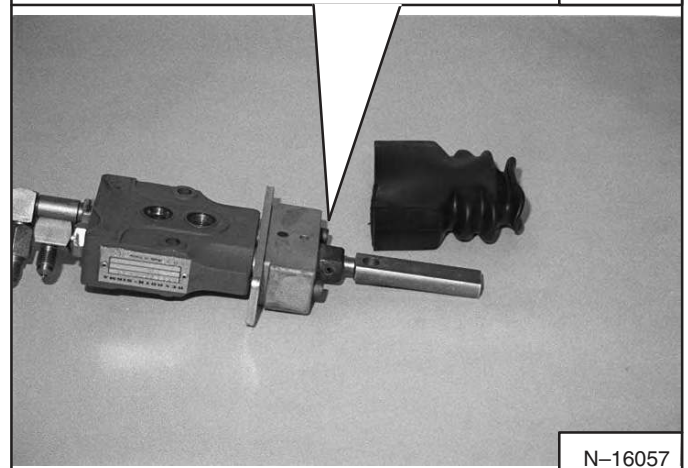
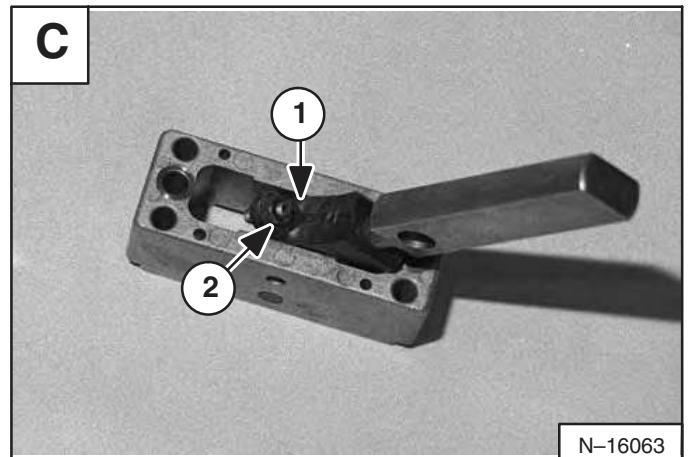

HYDROSTATIC MOTOR (Cont'd)

Assembly

IMPORTANT

When repairing hydrostatic and hydraulic systems, clean the work area before disassembly and keep all parts clean. Always use caps and plugs on hoses, tubelines and ports to keep dirt out. Dirt can quickly damage the system.

I-2003-0888

Install the center spring into the center pin. Put grease on the washer and install it in the cylinder block center bore [A].

Install the cylinder block on the pistons [B].

For easier installation of the piston/piston rings into the cylinder block, come straight down into the cylinder block bores [C].

Make sure all the parts are fitted together correctly.

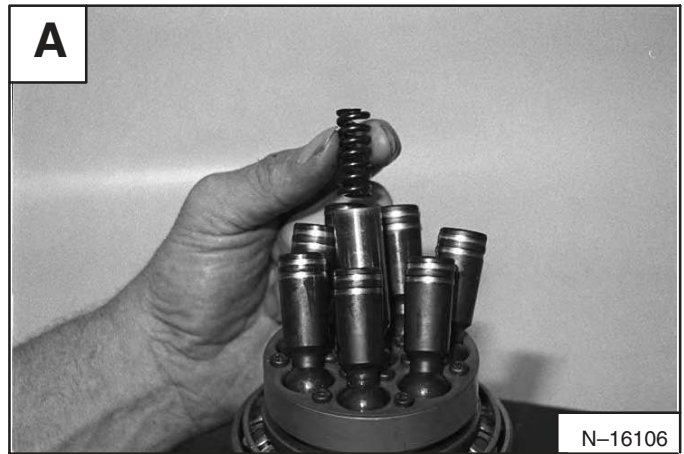

HYDROSTATIC PUMP (Cont'd)

Disassembly (Cont'd)

Remove the charge relief valve (Item 1) [A], seat (Item 2) [A] and spring (Item 3) [A] from the port block.

Use a punch and hammer to mark the charge pump housing and port block housing for correct installation of the charge pump [B].

Mark the port block to the pump housing for correct installation.

Remove the four mounting bolts (Item 1) [C] from the charge pump.

Remove the charge pump (Item 1) [D] from the port block.

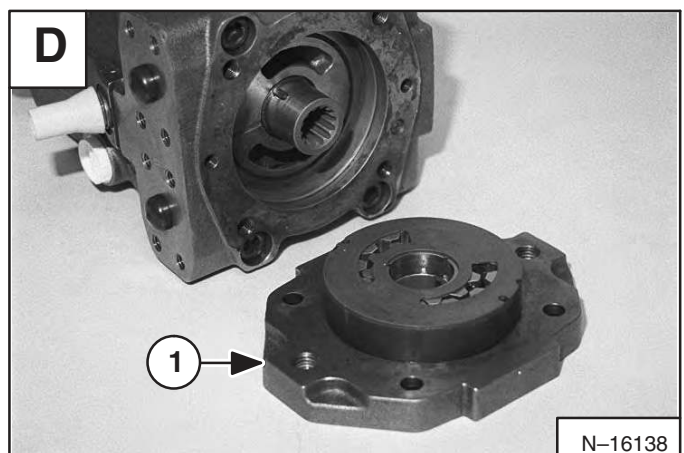
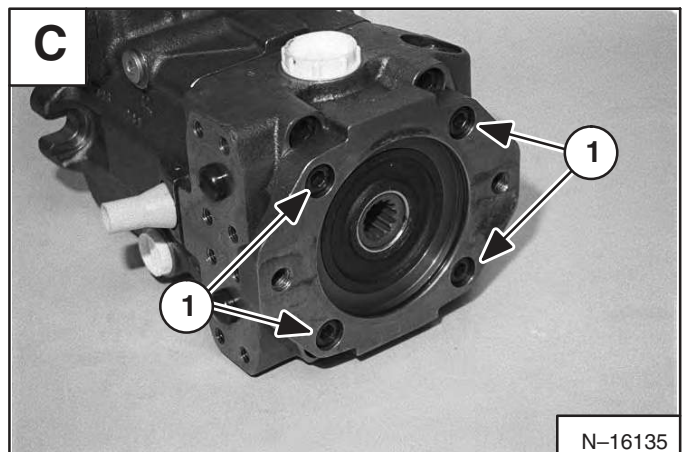
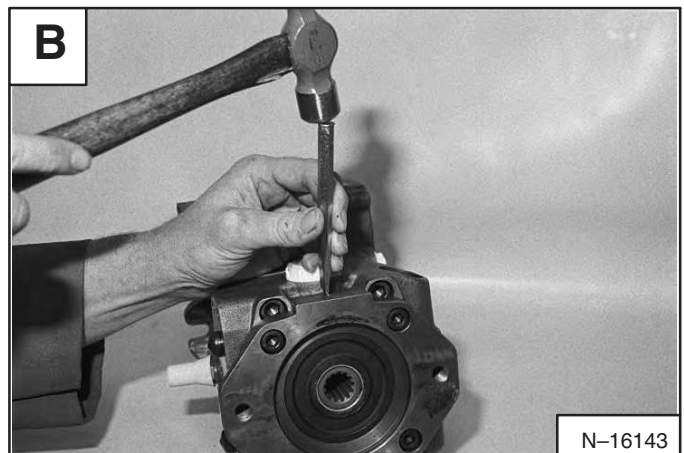
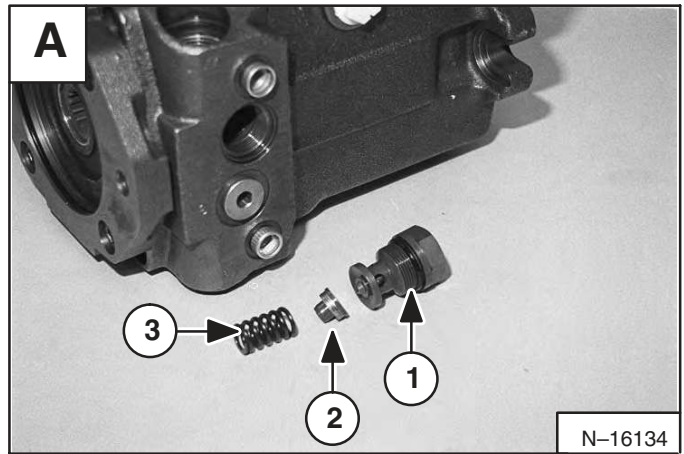

HYDROSTATIC PUMP (Cont'd)

Assembly

IMPORTANT

When repairing hydrostatic and hydraulic systems, clean the work area before disassembly and keep all parts clean. Always use caps and plugs on hoses, tubelines and ports to keep dirt out. Dirt can quickly damage the system.

I-2003-0888

Right Pump: Install the drive shaft (Item 1) [A] into the pump housing.

Install the snap ring (Item 2) [A].

Right Pump: Install the drive shaft seal using a bearing driver tool [B].

Right Pump: Install the snap ring (Item 1) [C] into the pump housing.

Left Pump: Install the drive shaft and snap ring into the pump housing.

Left Pump: Install the drive shaft seal using a bearing driver tool [D].

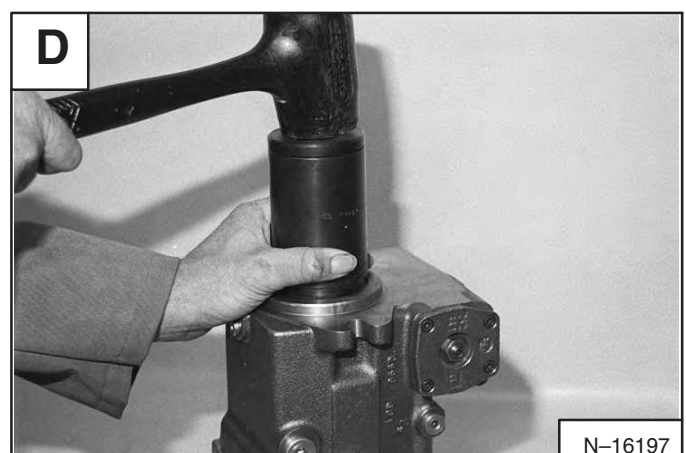
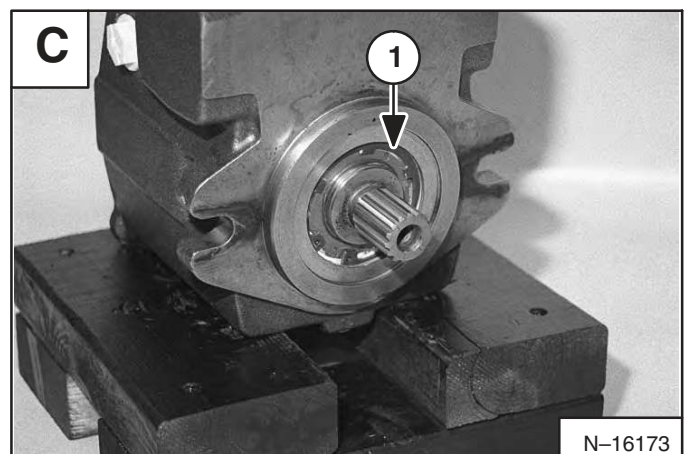
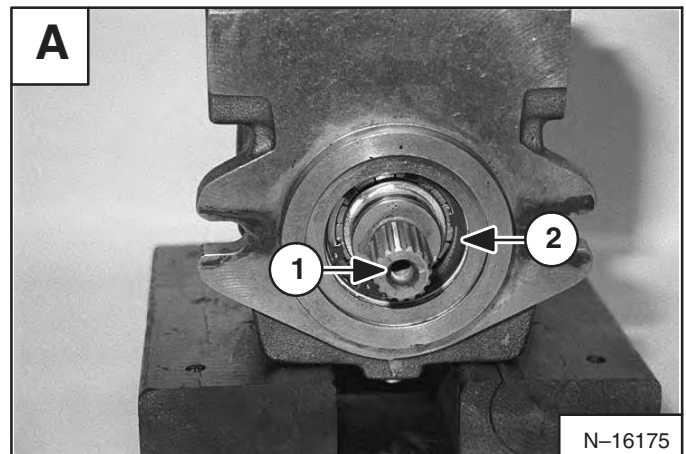

HYDROSTATIC PUMP (Cont'd)

Assembly (Cont'd)

Install the two hydrostatic pump halves together [A].

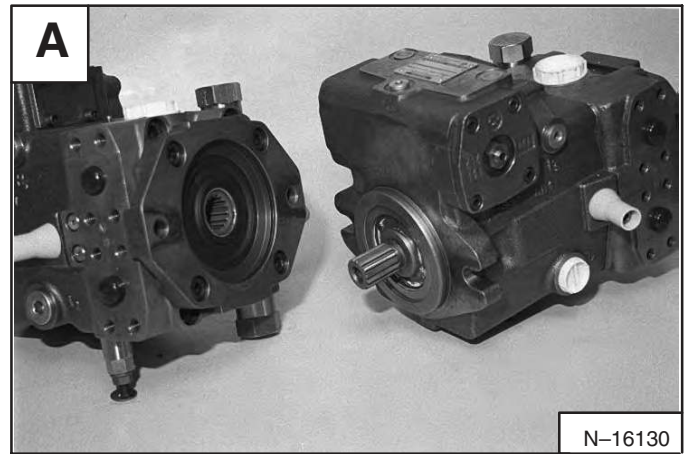

Install the bolt (Item 1) [B] and tighten to 75 ft.-lbs. (102 Nm) torque (both sides).

Hydrostatic Pump Start-Up

Disconnect the fuel shut-off solenoid at the fuel injection pump.

Crank the engine, with the starter, for 15–20 seconds.

Connect the fuel shut-off solenoid.

Start the engine and run at idle speed for 5–7 minutes before operating the loader. Do Not run the engine above idle speed while doing the above procedure.

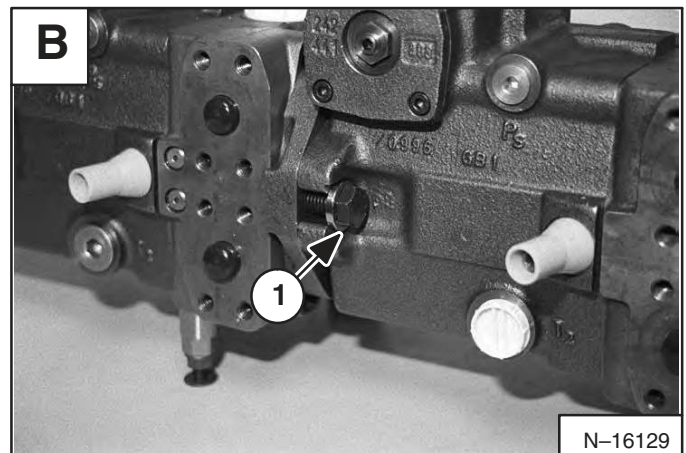

HYDROSTATIC MOTOR COVER

Removal And Installation

Lift and block the loader. (See Page 1-1.)

Remove the wheel nuts and remove the tire/wheel assembly from the hub.

Installation: Tighten the wheel nuts to 320–350 ft.-lbs. (434–475 Nm) torque.

Remove the mounting bolts (Item 1) [B] from the motor access cover.

Installation: Tighten the mounting bolts to 220–245ft.-lbs. (298–332 Nm) torque.

Remove the access cover from the loader frame.

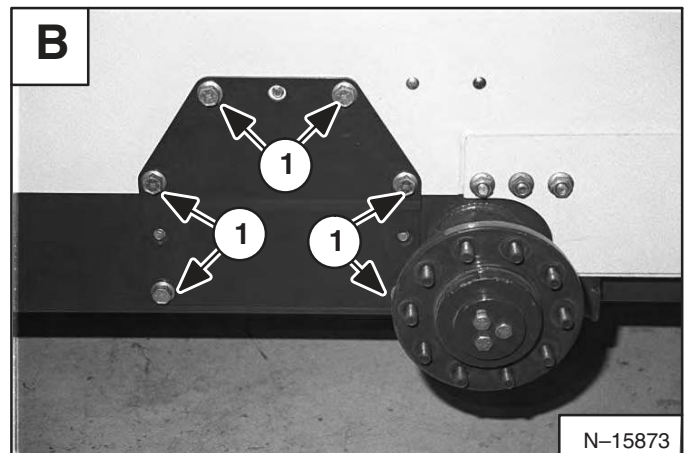

PARKING BRAKE

Removal And Installation

Lift and block the loader. (See Page 1-1.)

Raise the operator cab. (See Page 1-1.)

Remove the brake/two speed block from the center cover on the chaincase. (See Page 4-5.)

Remove the bolts from the center cover (Item 1) [A] on the chaincase.

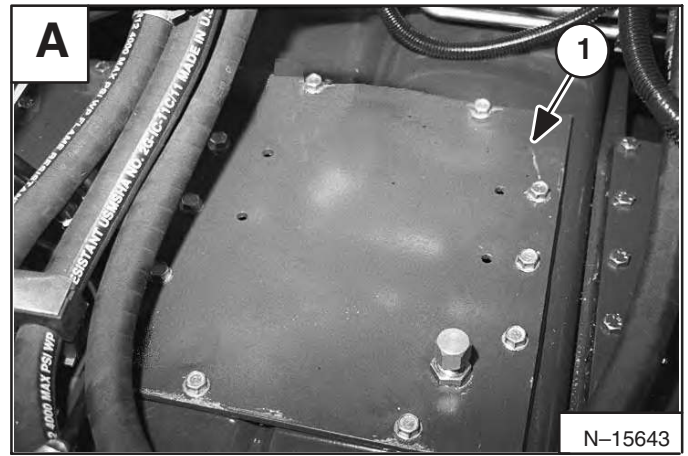

Disconnect the cross-over hose (Item 1) [B] at the fitting on the brake housing.

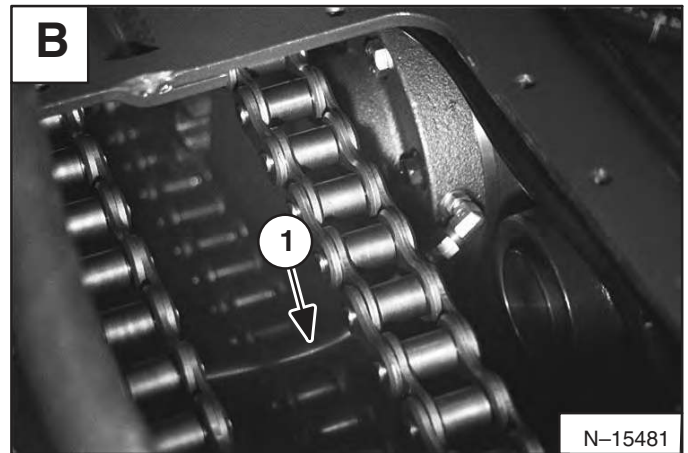

Remove the two mounting bolts (Item 1) [C] and [D].

Installation: Tighten the mounting bolts to 70 ft.-lbs. (95 Nm) torque.

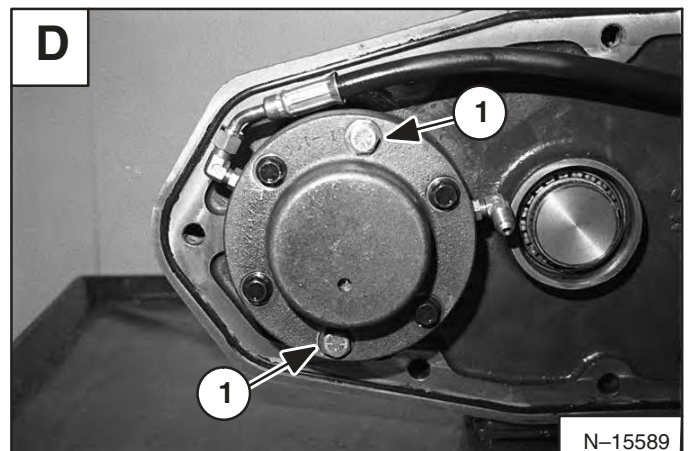
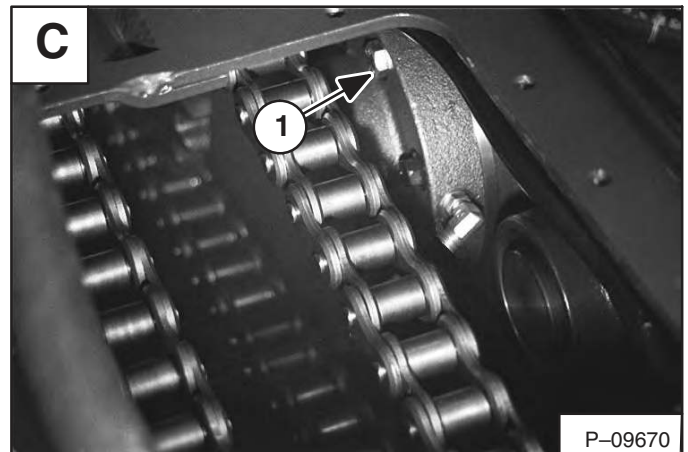

AXLE, BEARINGS AND SPROCKET (Cont'd)

Removal And Installation (Cont'd)

Installation: Install the long threaded bolt into the axle tube. Install the correct size bearing cup driver tool (Item 1) [A] (MEL1202-11). Install the nut and washer on the threaded bolt.

Installation: Inside the chaincase, start the inner bearing cup into the axle tube. Install a bearing cup driver tool (Item 1) [B] (MEL1202-12). Install the nut and washer.

Installation: Install a wrench (Item 1) [C] on the nut and have a second person hold the wrench.

Installation: Turn the nut on the outside of the axle tube until the inner bearing cup is on its seat [D].

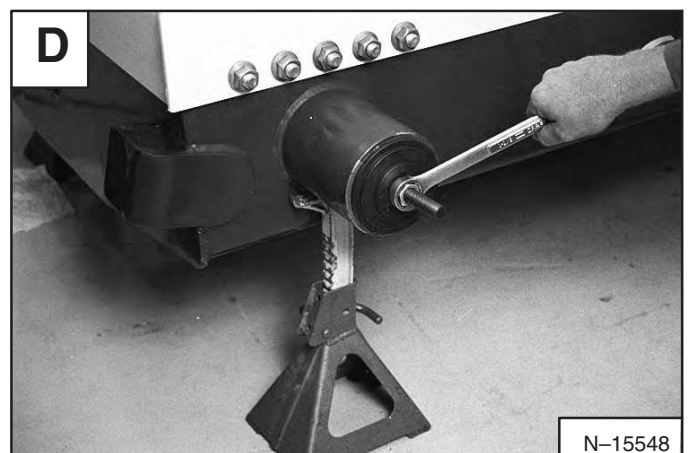
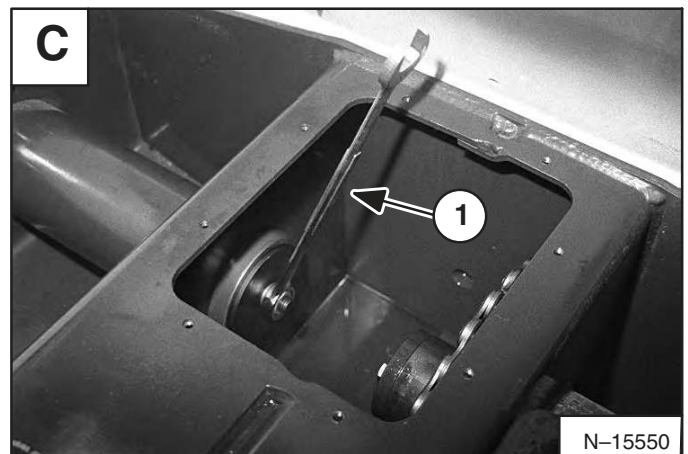
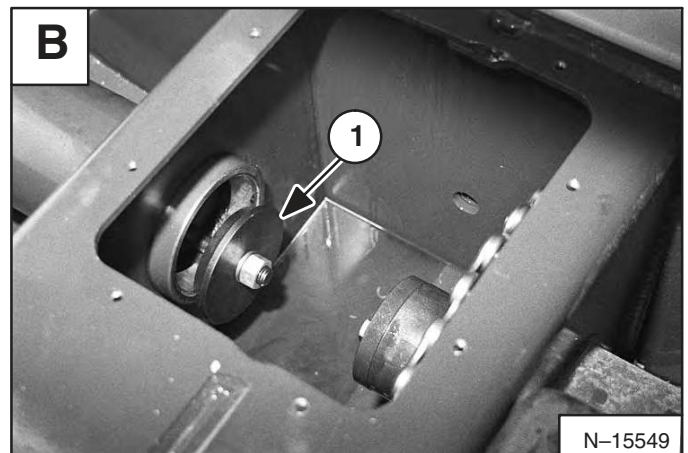
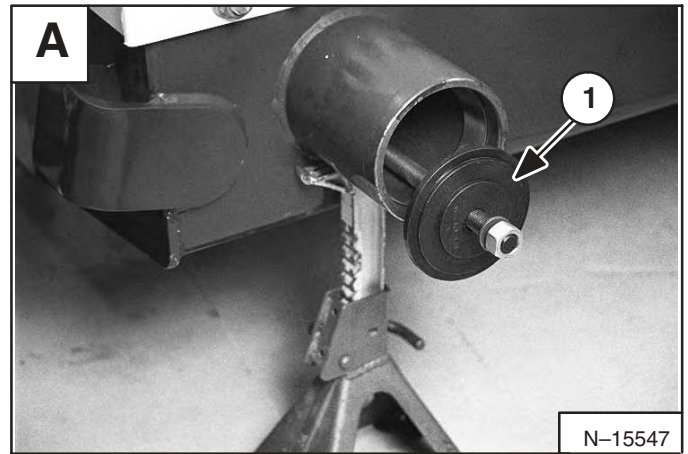

REDUCTION GEARCASE (Cont'd)

Disassembly And Assembly (Cont'd)

Remove the bearing [A].

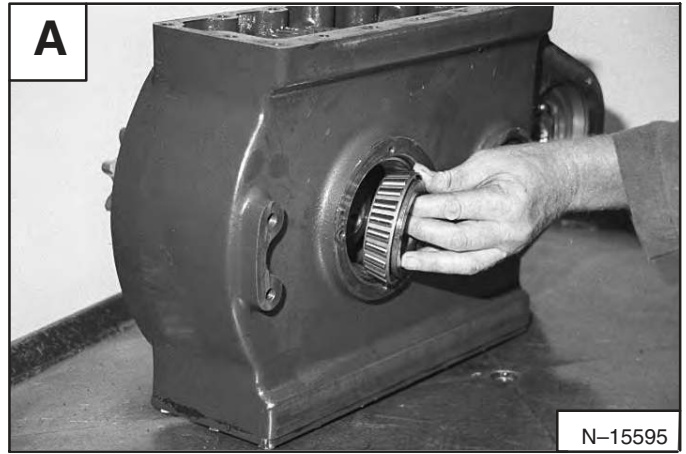

Remove the spacer [B].



Assembly: Install the spacer . Support the drive shaft.
Install the bearing using a hammer [C].



Remove the drive shaft (Item 1) [D] and spacer (Item 2) [D] from the gearcase housing.

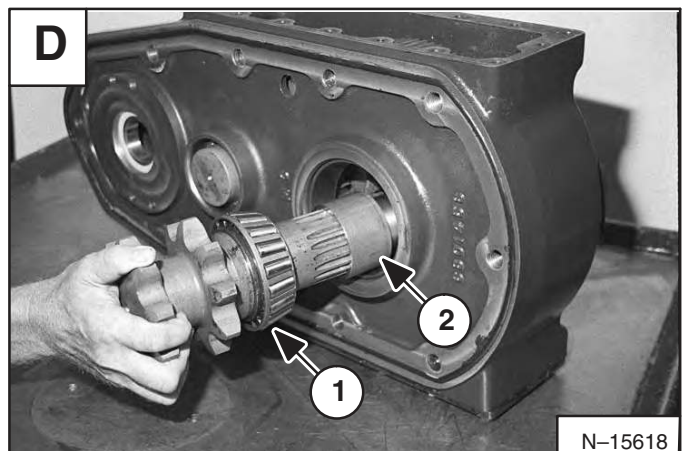

SEAT BAR

Removal And Installation

Lower the seat bar (Item 1) [A] so the compression springs (Item 2) [A] will be in a down position.

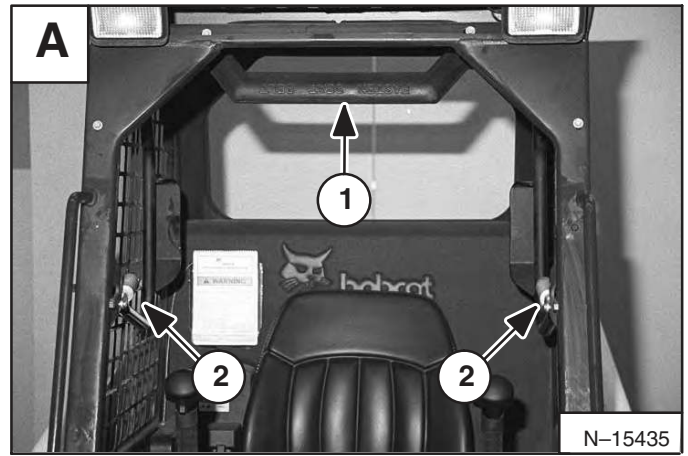

Loosen the adjustment lock nut (Item 1) [B] (both sides).

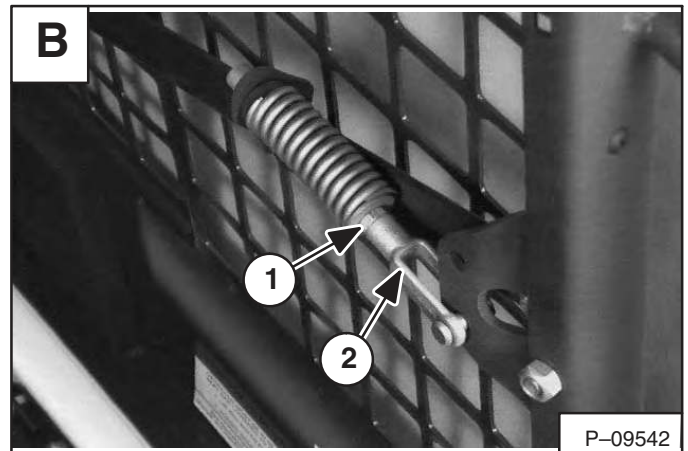

Turn the bolt (Item 1) [C] into the clevis five turns (both sides).

Installation: When properly adjusted the clearance distance between the bolt head (Item 1) [C] and the seat bar tab (Item 2) [C] is 1/16 inch (1,58 mm).

Tighten the adjustment lock nut (Item 3) [C] to the clevis.

Repeat above installation procedure for other side. The compression spring is adjusted correctly when the bolt is flush with the clevis (Item 2) [B].

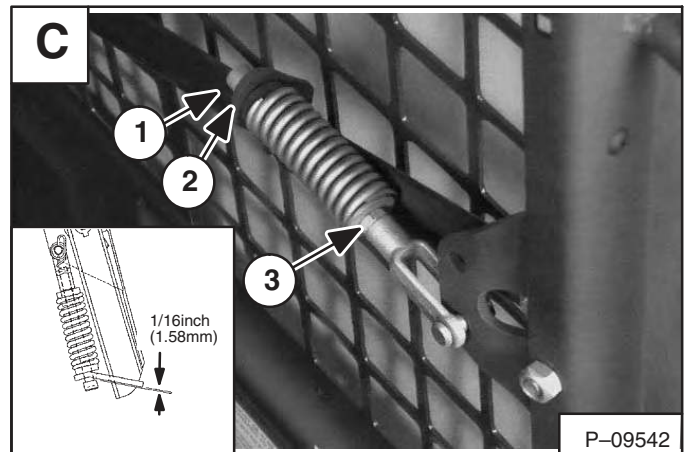

Remove the retaining pin (Item 1) [D] and clevis pin (both sides).

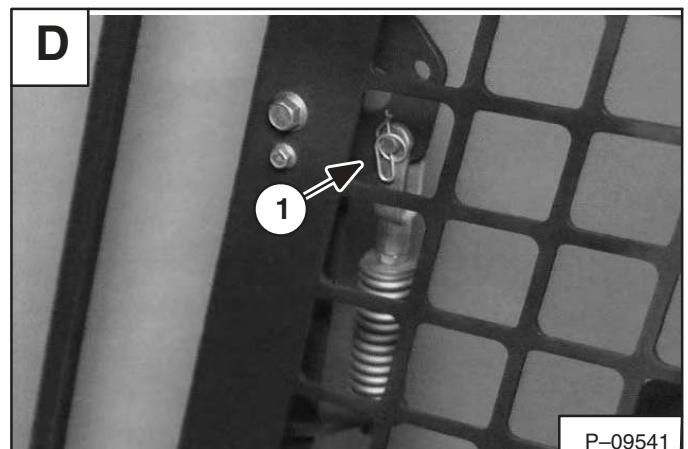

BOB-TACH (Cont'd)

Removal And Installation (Cont'd)

Remove the retainer bolt (Item 1) [A] at the Bob-Tach pivot pin (both sides).

Installation: Tighten the retainer bolt to 16–20 ft.-lbs. (21–27 Nm) torque.

Remove the Bob-Tach pivot pin (Item 1) [B] (both sides).

Remove the Bob-Tach from the lift arms.

Installation: Make sure the shims (Item 1) [C] are installed when the Bob-Tach is installed on the lift arms.

Check the bushings in the lift arms for wear and damage, replace as needed [D].

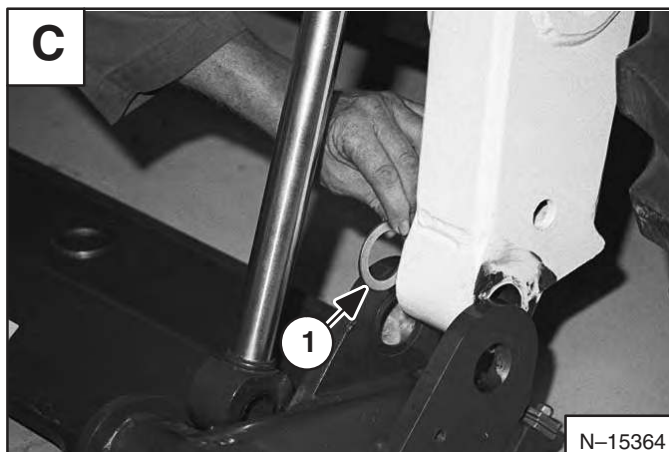
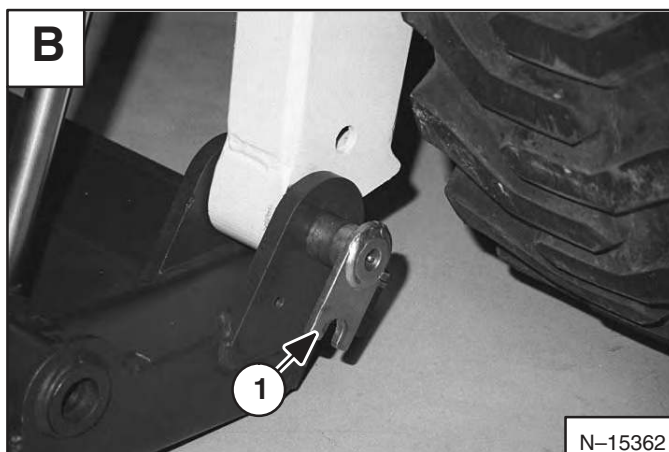
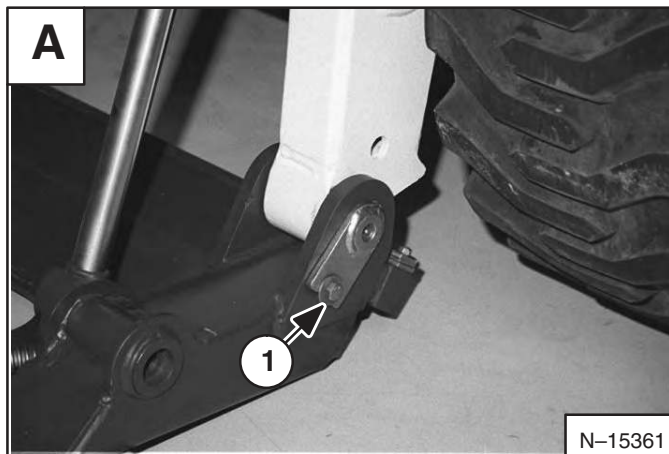

CLICK HERE TO **DOWNLOAD** THE COMPLETE MANUAL

- Thank you very much for reading the preview of the manual.
- You can download the complete manual from: www.heydownloads.com by clicking the link below



- Please note: If there is no response to **CLICKING** the link, please download this PDF first and then click on it.

CLICK HERE TO **DOWNLOAD** THE COMPLETE MANUAL

FRONT FUEL TANK

Removal And Installation

Remove the drain plug (Item 1) [A].

Drain the fuel into a container.

Check the drain plug and replace if necessary.

Lift and block the loader. (See Page 1-1.)

Raise the lift arm and install an approved lift arm support device. (See Page 1-1.)



WARNING

Never work on a machine with the lift arms up unless the lift arms are secured by an approved lift arm support device. Failure to use an approved lift arm support device can allow the lift arms or attachment to fall and cause injury or death.

W-2059-0598

Stop the engine.

Raise the operator cab. (See Page 1-1.)

Remove the front panel/steering levers assembly. (See Page 3-1.)

Remove the hydraulic foot pedals and foot pedal mounting plate. (See Page 2-1.)

Move the two hose clamps (Item 1)[B] from the hose onto the tube.

Disconnect the hose from the fuel tank.

Remove the two bolts (Item 2)[B] from the gearcase and remove the bracket.

Disconnect the vent hose (Item 1) [C].

Disconnect the wire harness connector at the fuel sender (Item 2) [C].

Remove the front fuel tank from the loader frame.

Fuel Level Sender

Loosen the fuel level sender in the fuel tank. Remove the sender (Item 1) [D]. from the tank.

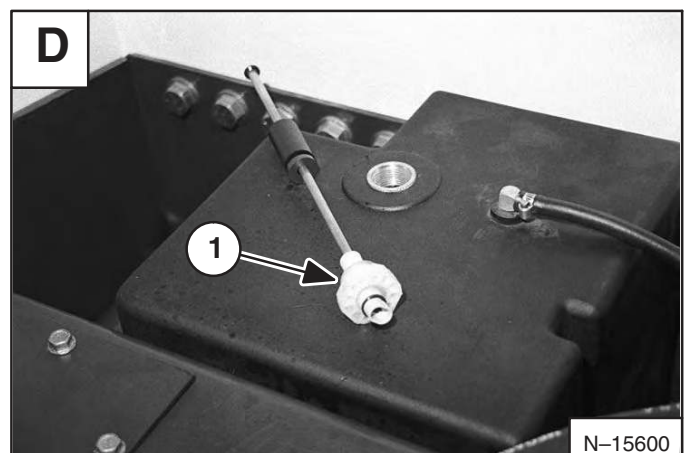
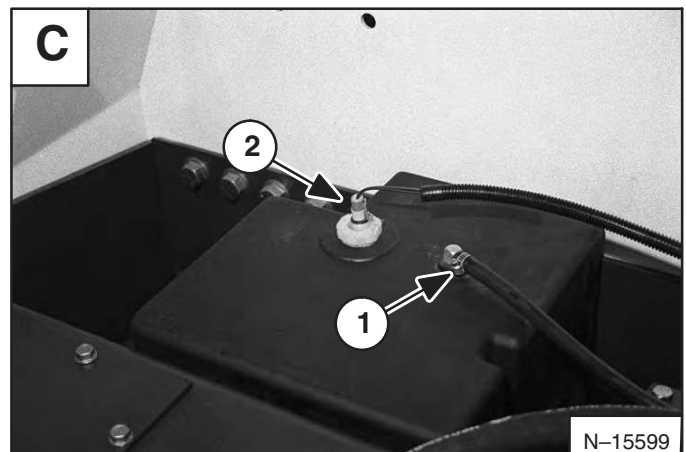
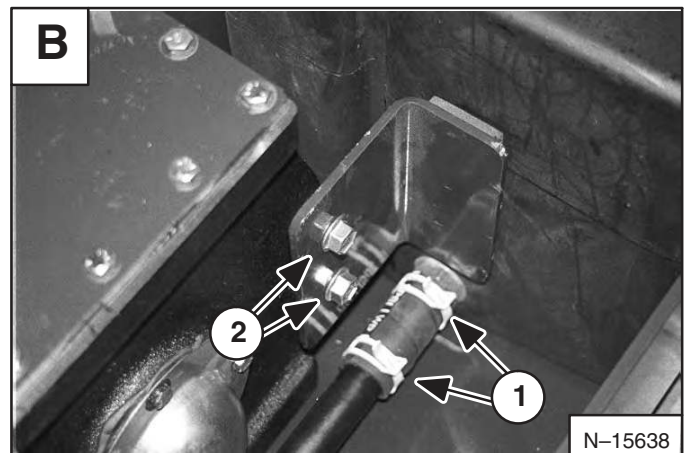
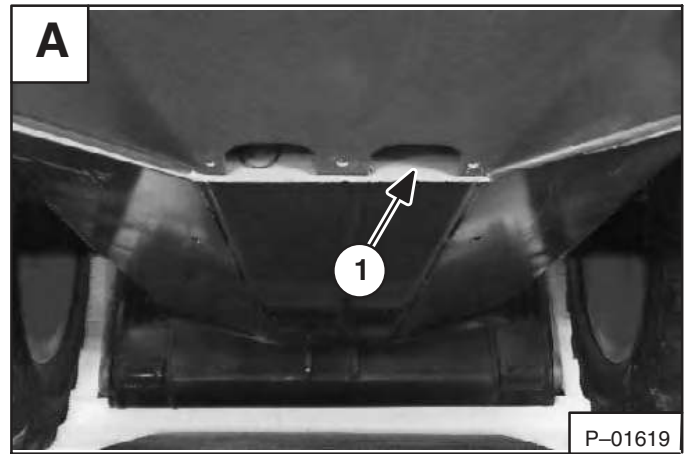

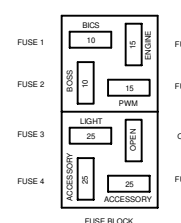
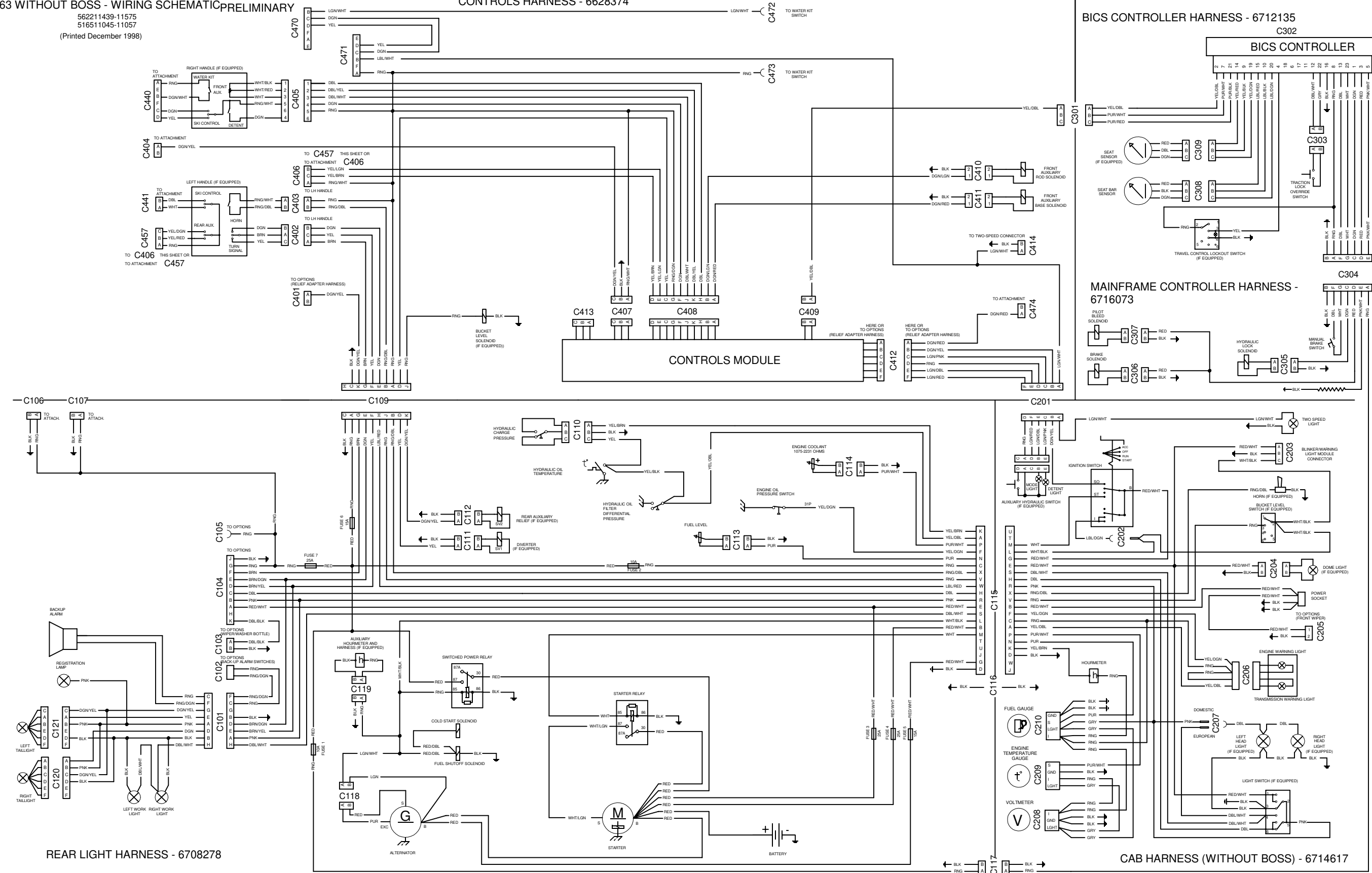

WIRES CONNECT BY LETTER ACROSS CONNECTORS

SOME CONNECTOR BODIES NOT SHOWN FOR DRAWING CLARITY

963 BOSS - WIRING SCHEMATIC
 WITH ADVANCED HAND CONTROL OPTION
 562211576 AND ABOVE
 516511058 AND ABOVE
 (P rnted December 1998)

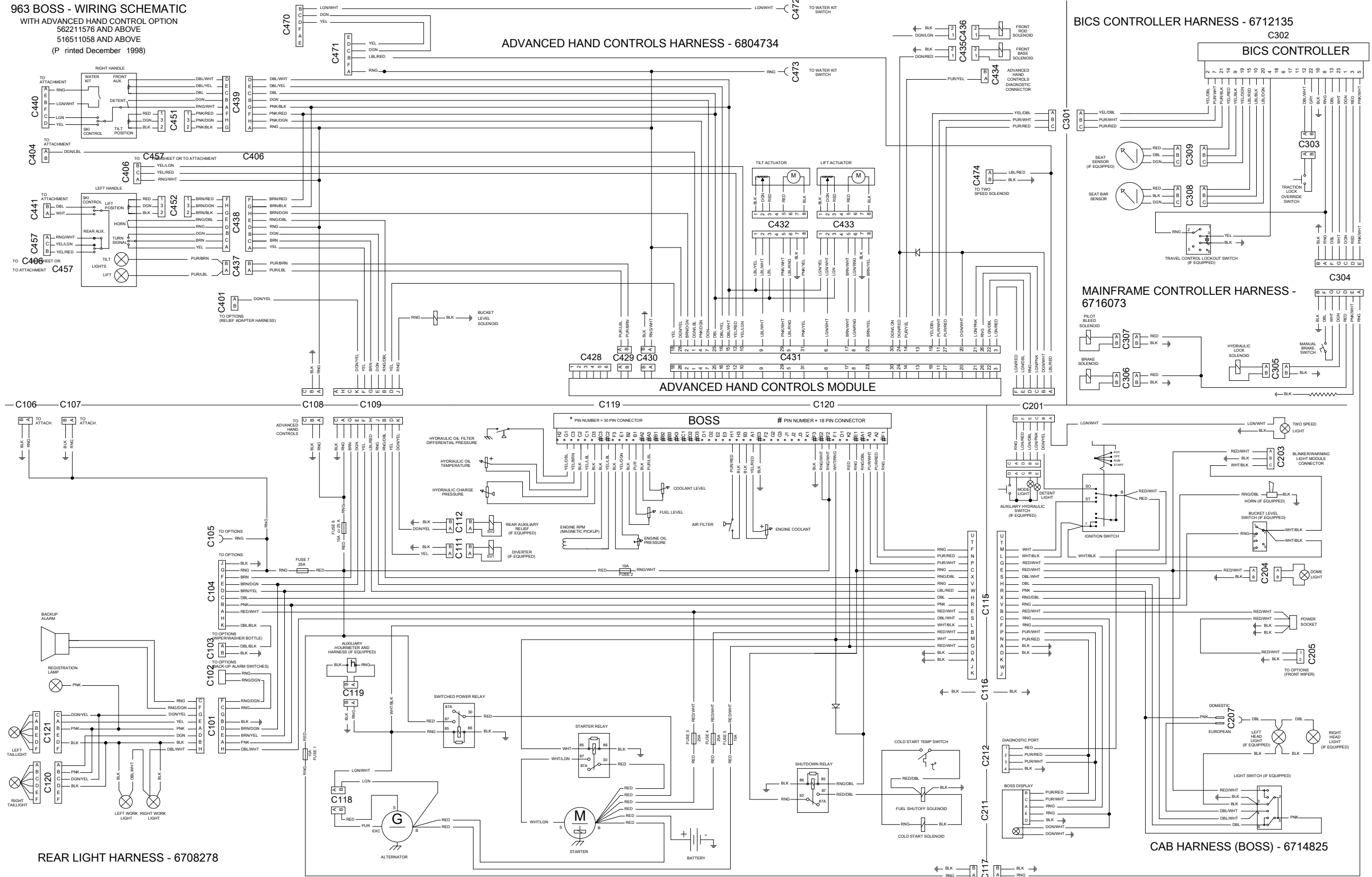

FUSE 1	BICS	10	15	ENGINE
FUSE 2	BOSS	10	25	FWM
FUSE 3	LIGHT	25	OPEN	
FUSE 4	ACCESSORY	25	ACCESSORY	
FUSE 5				
FUSE 6				
FUSE 7				

FUSE BLOCK

WIRES CONNECT BY LETTER ACROSS CONNECTORS

SOME CONNECTOR BODIES NOT SHOWN FOR DRAWING CLARITY

BATTERY (Cont'd)

Removal and Installation (Cont'd)

Always clean the terminals and cable ends when installing a new battery [A] and [B].

When installing the battery in the loader do not touch any metal parts with the battery terminal posts.

Connect and tighten the battery cables. Connect the negative (-) cable last to prevent sparks.



WARNING

Batteries contain acid which burns eyes and skin on contact. Wear goggles, protective clothing and rubber gloves to keep acid off body.

In case of acid contact, wash immediately with water. In case of eye contact get prompt medical attention and wash eye with clean, cool water for at least 15 minutes.

If electrolyte is taken internally drink large quantities of water or milk. DO NOT induce vomiting. Get prompt medical attention.

W-2065-1296

Servicing The Electrical System

The battery cables must be clean and the connections tight. Remove acid or corrosion from the battery and cables with a sodium bicarbonate (baking soda) and water solution [C].

Clean the terminals and cable ends as shown in Fig. [A] and [B].

Check the electrolyte level in the battery. Add distilled water as needed.

Put Battery Saver (P/N 6664458) or grease on the battery terminals and cable ends to prevent corrosion.

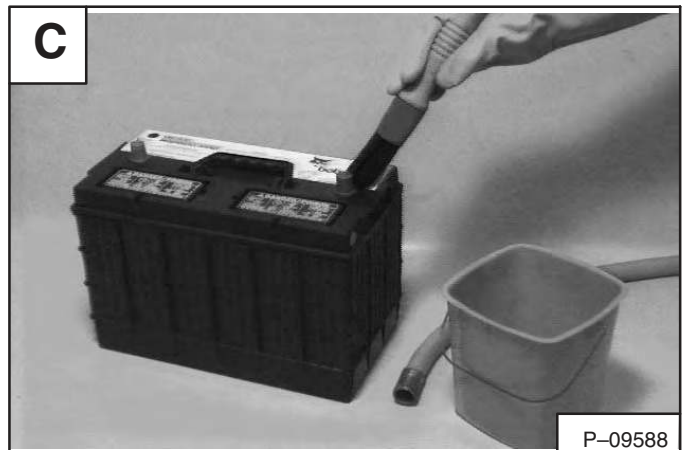
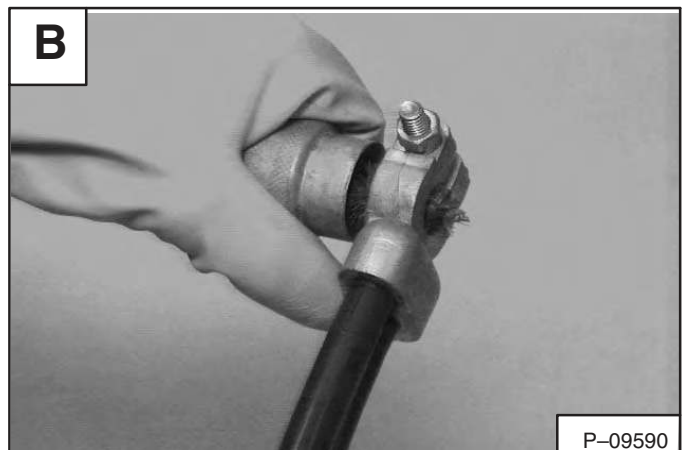
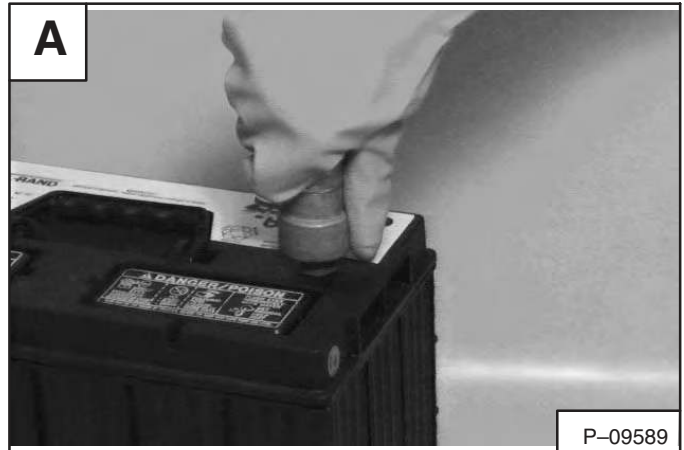

STARTER

Removal And Installation

Open the rear door.

Disconnect the negative (-) cable from the battery.

Remove the drive belt shield. (See Page 3-1.)

Disconnect the positive (+) cable (Item 1) [A] from the starter solenoid.

Disconnect the wires (Item 1)[B] from the starter solenoid terminal.

Disconnect the ground cable (Item 2) [B] at the starter mounting bolt.

Remove the nuts (Item 1) [C] & [D] and mounting bolts (flywheel side) from the starter.

Remove the starter.

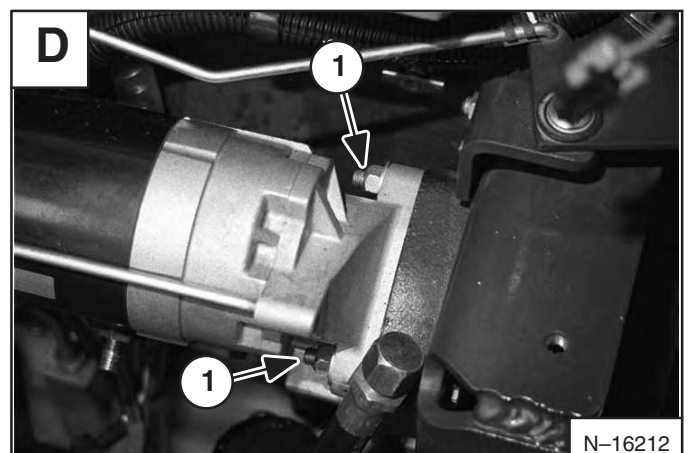
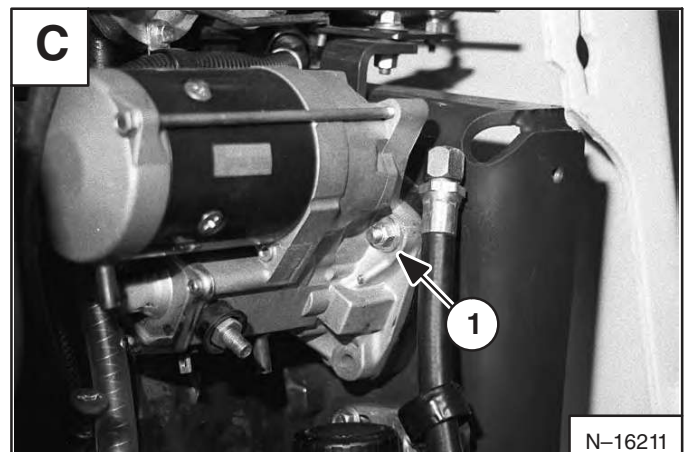
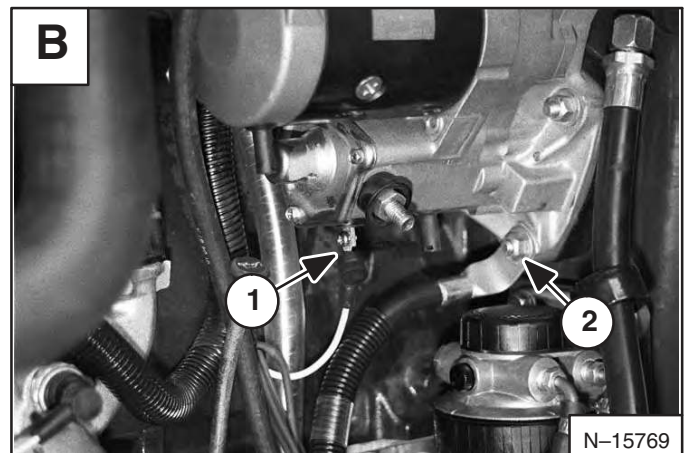
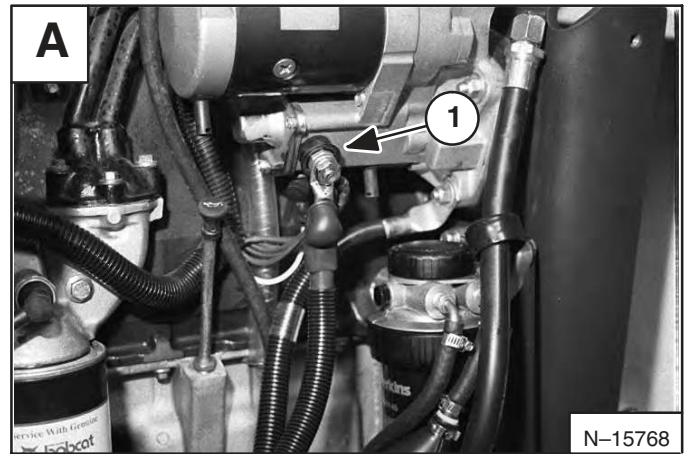

STANDARD INSTRUMENT PANEL

Removal And Installation

Pry the rubber light mount loose from the operator cab (both sides) [A].

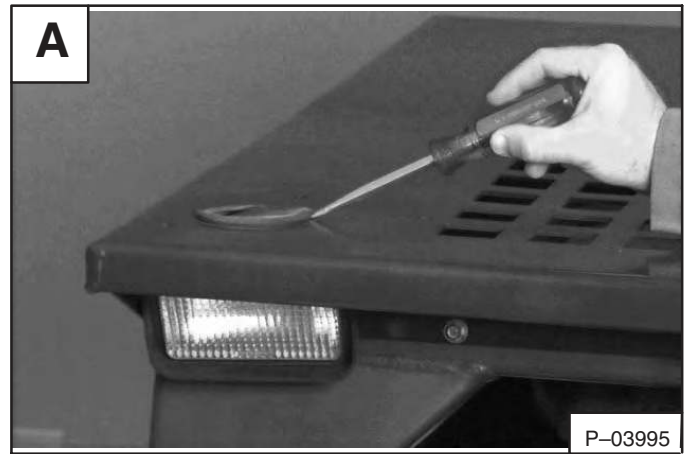

Lower the light from the operator cab and locate the three instrument panel mounting bolts (Item 1) [B] (both sides).

Remove the three mounting bolts (Item 1) [B].

Installation: Be careful not to overtighten the instrument panel mounting bolts to prevent stripping the threaded holes in the panels.

Mark all wires for ease of assembly.

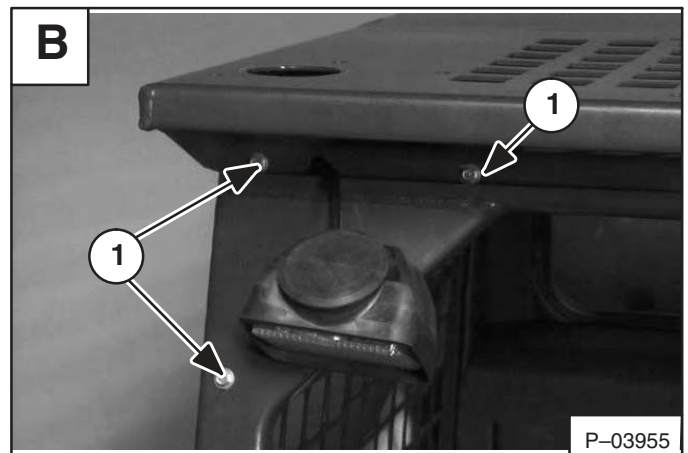

Pull the left instrument panel down and disconnect the wire harness connectors from the panel. Remove the panel [C].



Mark all wires for ease of assembly.

Repeat steps [A] and [B]. Pull the right instrument panel down and disconnect the wire harness connectors from the panel. Remove the panel [D].

Reverse the removal procedure to install the instrument panel.



AIR CLEANER HOUSING

Removal And Installation

Open the rear door.

Raise the rear grill.

Disconnect the intake hose (Item 1) [A] from the air cleaner housing.

Remove the bolt and nut from the mounting strap (Item 2) [A] (both sides).

Remove the air cleaner housing from the mounting straps.

Remove the two bolts from the mounting strap (Item 1) [B].

Remove the mounting strap.

Repeat procedure for the other mounting strap.

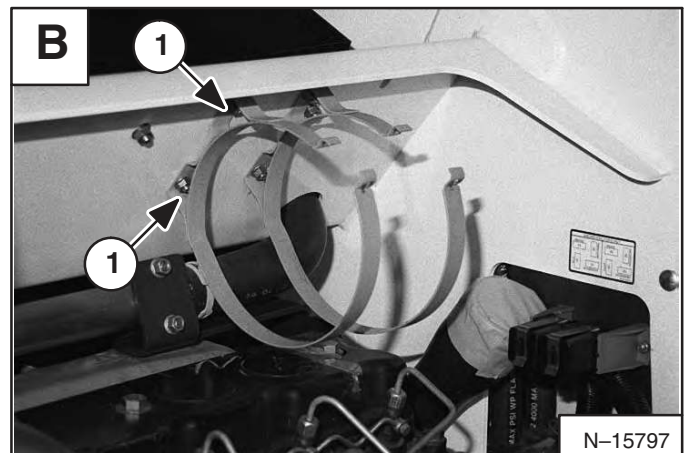
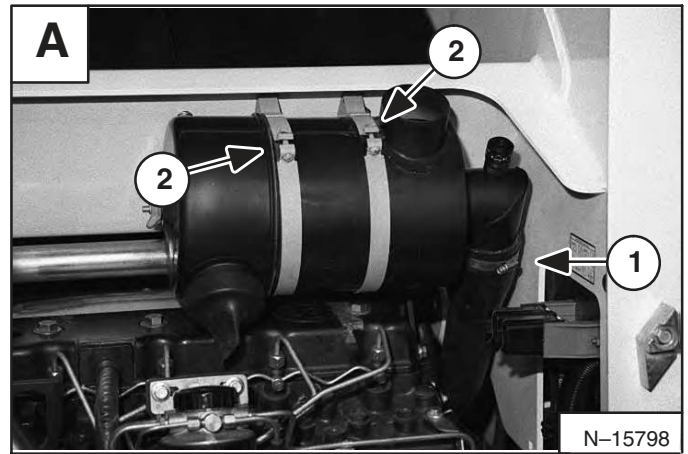

FAN GEARBOX

Disassembly

Remove the three pulley bolts (Item 1) [A]. Turn them into the next set of holes on the pulley. Tighten the bolts evenly until the pulley is removed from the hub.

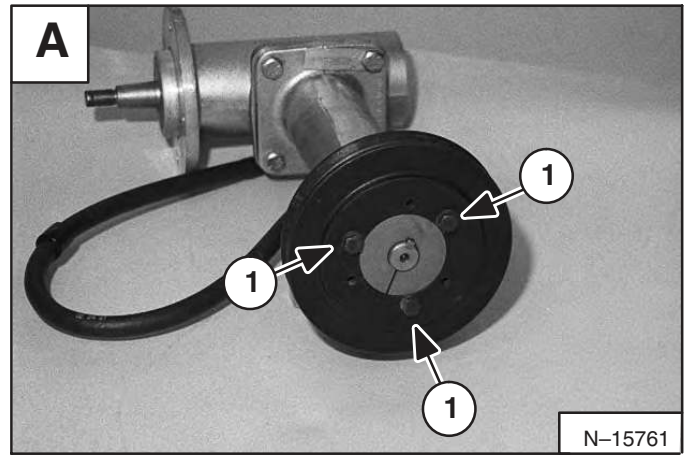

Loosen the set screw, using a allen wrench (Item 1) [B].

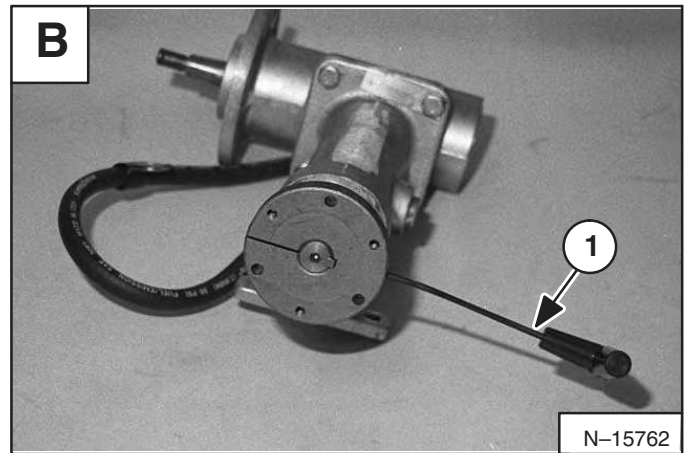

Remove the hub from the fan gearbox shaft [C].

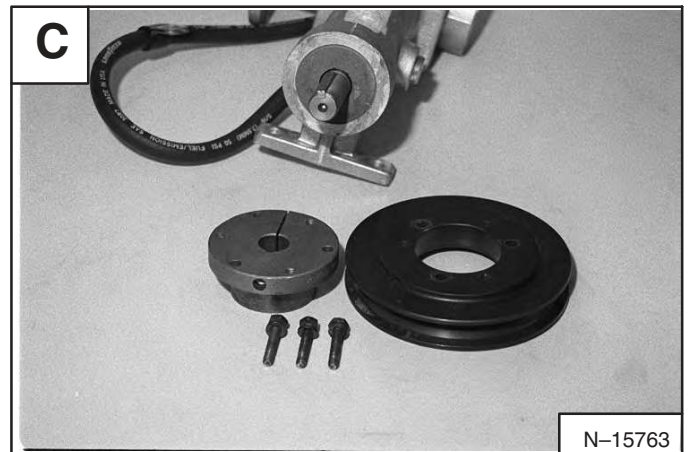

FAN GEARBOX (Cont'd)

Assembly (Cont'd)

Install the snap ring in the groove above the bearing **[A]**.



Install the washer (Item 1) **[B]** on the shaft. Put liquid adhesive (LOCTITE #242) on the screw threads and install the screw **[B]**.

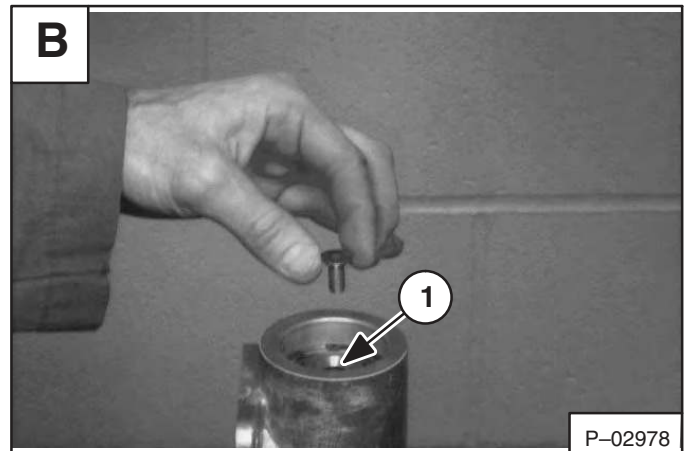

FUEL INJECTOR NOZZLES

Removal and Installation



WARNING

Diesel fuel or hydraulic fluid under pressure can penetrate skin or eyes causing serious injury. Fluid leaks under pressure may not be visible. Use a piece of cardboard or wood to find leaks. Do not use your bare hand. Wear safety goggles. If fluid enters skin or eyes, get immediate medical attention.

W-2074-1285

Disconnect the tubeline (Item 1) [A] from the top of the fuel injection pump.

Disconnect the tubeline (Item 2) [A] from the injector pump.

Disconnect the tubelines (Items 3, 4, & 5) [A] from the fuel filter housing.

Disconnect the injector tubelines (Item 1) [B] from the injector pump.

Installation: Tighten the tubeline fittings to 16 ft.-lbs. (22 Nm) torque.

IMPORTANT

Do not bend the high pressure fuel injection tubes when removing or installing them.

I-2029-0289

Disconnect the injector tubelines (Item 1) [C] from the fuel injectors.

Disconnect the fuel return tubeline (Item 2) [C] and remove the tubeline.

Remove the high pressure injector tubelines from the engine.

Disconnect the fuel return tubeline (Item 1) [D] at the fuel injectors.

Remove the fuel return tubeline from the engine.

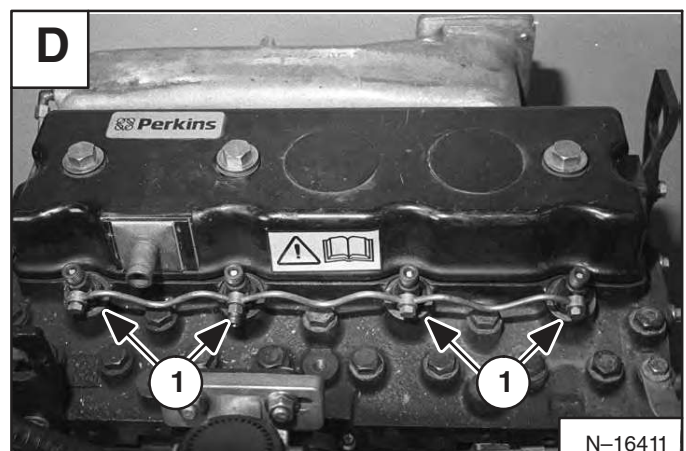
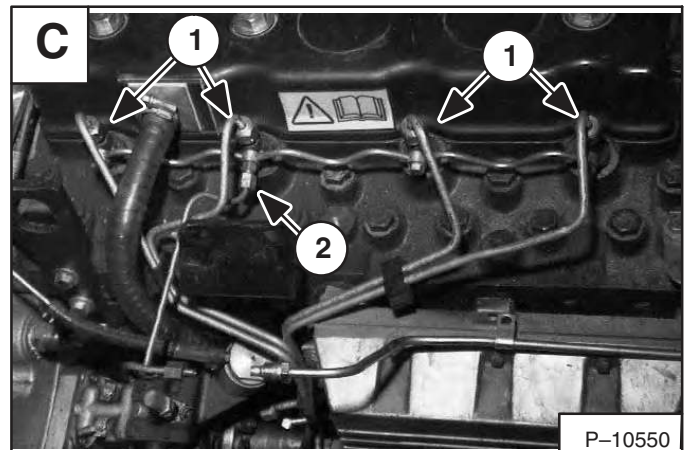
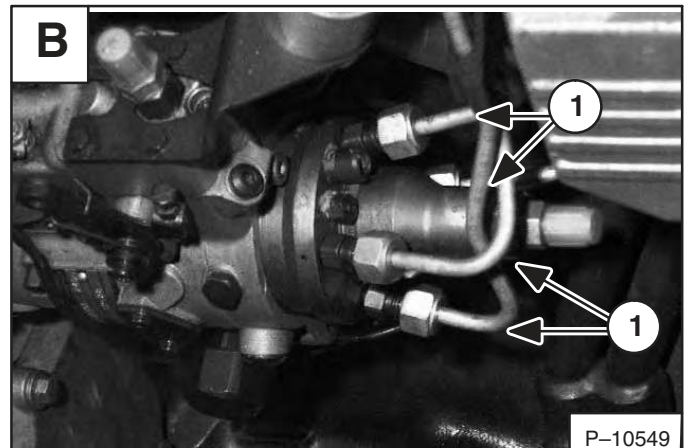
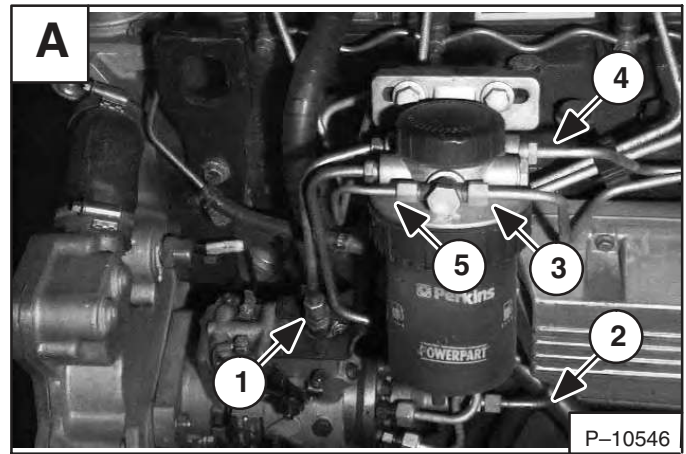

CYLINDER HEAD

Removal

Remove the turbocharger. (See Page 7–92.)

Remove the oil cooler. (See Page 7–79.)

Remove the intake manifold. (See Page 7–47.)

Remove the exhaust manifold. (See Page 7–48.)

Disconnect the tubeline (Item 1) [A] from the top of the fuel injector pump.

Disconnect the tubeline (Item 2) [A] from the injector pump.

Disconnect the tubeline (Items 3, 4 & 5) [A] from the top side of the fuel filter.

Remove the mounting bolts (Item 6) [A] from the fuel filter mounting bracket.

Remove the fuel filter mounting bracket and fuel filter from the engine.

Disconnect the injector tubelines (Item 1) [B] from the injector pump.

Disconnect the injector tubelines (Item 1) [C] from the injectors.

Disconnect the fuel tubeline (Item 2) [C] and remove the tubeline.

Remove the injector tube lines from the engine.

IMPORTANT

Do not bend the high pressure fuel injection tubes when removing or installing them.

I-2029-0289

Remove the fuel injectors. (See Page 7–39.)

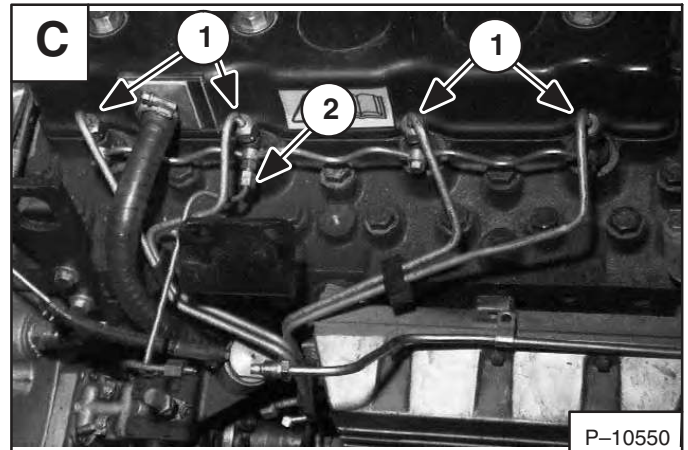
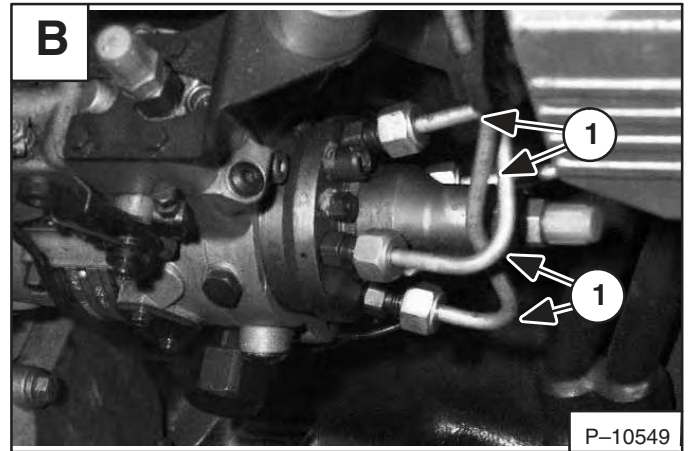
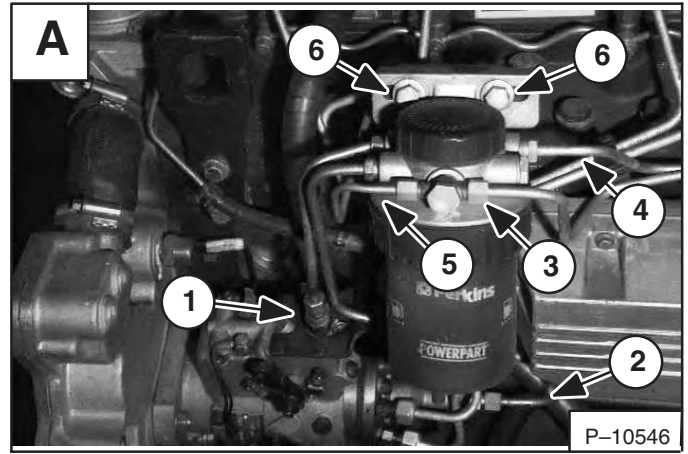

VALVES, VALVE GUIDES AND SPRINGS (Cont'd)

Changing Valve Springs (With Cylinder Head Installed)

Remove the rocker cover.

Rotate the crankshaft clockwise until the intake valve has opened and the exhaust valve has not fully closed. In this position the piston (Item 1) [A] will be at approximately T.D.C.

Remove the rocker shaft assembly.

Install the valve spring compressor and adaptor [B].

Compress the valve springs and remove the retainers.

NOTE: Do not rotate the crankshaft while the valve springs are removed.

Release the compressor and remove the valve spring(s).

Place the new valve springs in position.

Compress the valve springs and install the retainers.

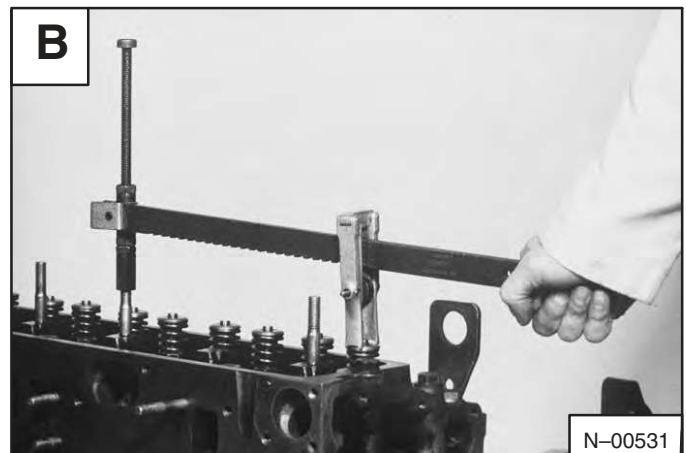
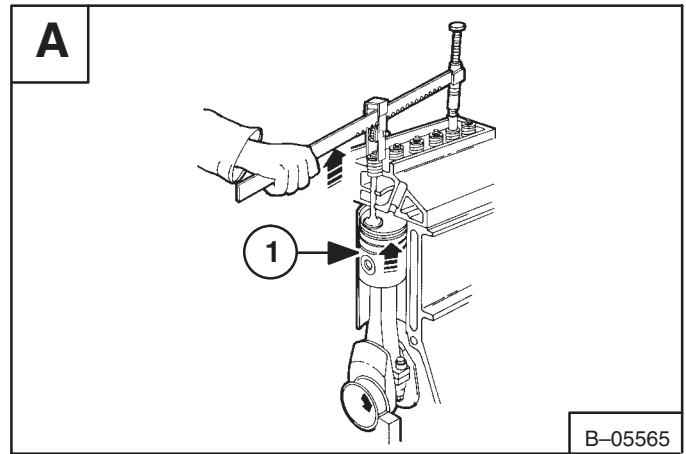

PISTON AND CONNECTING ROD (Cont'd)

Connecting Rod Inspection

Checking the connecting rod for distortion [A].

NOTE: The large and small end bores must be square and parallel within the limits of ± 0.010 inch (0,25 mm).

Measure this 5.0 inch (127 mm) on each side of the connecting rod axis on a test fixture.

With the piston pin bushing installed the limit is reduced to ± 0.0025 inch (0,06 mm).

Check the pin bushing for wear or damage. Replace as needed.

Connecting Rod Bushing Replacement

Press out the old bushing. Clean the bore and remove any burrs.

Press in the new bushing making sure the oil feed holes line up.

Ream the bushing to get the proper clearance of 0.0008 – 0.0017 inch (0,02 – 0,043 mm) between the small end bushing and piston pin.

Assembly

Install the connecting rod (Item 1) [B], piston pin (Item 2) [B] and two snap rings (Item 3) [B] in the piston.

Installation

Apply a light coat of oil to the piston and piston rings.

NOTE: Make sure the piston ring end gaps are 120° apart.

Install the ring compressor over the piston rings [C].

Carefully place the connecting rod in the cylinder and using a hammer handle, push the piston in the bore.

When the piston has cleared the cooling jet, rotate the piston assembly so that the arrow or *FRONT* mark is toward the front of the engine [D].

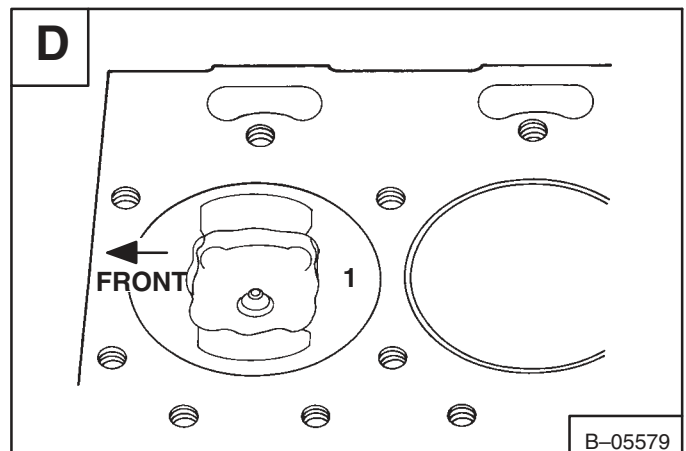
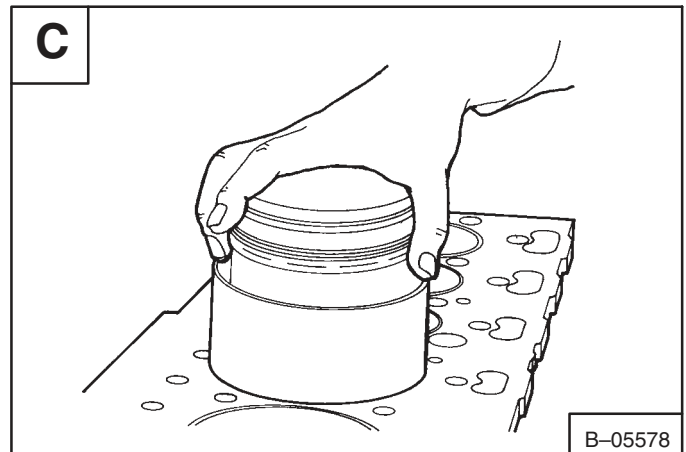
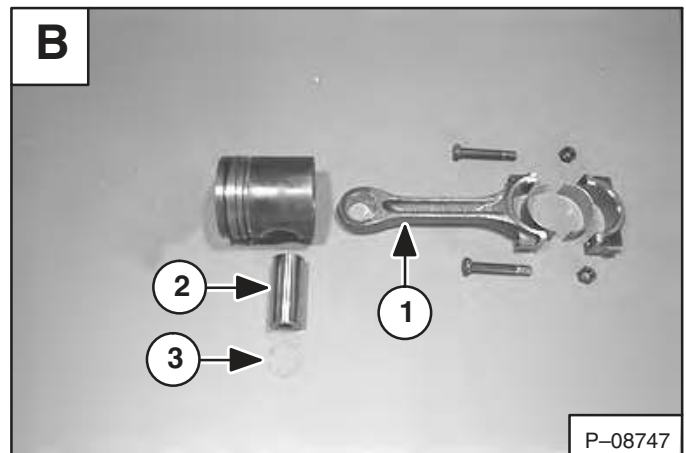
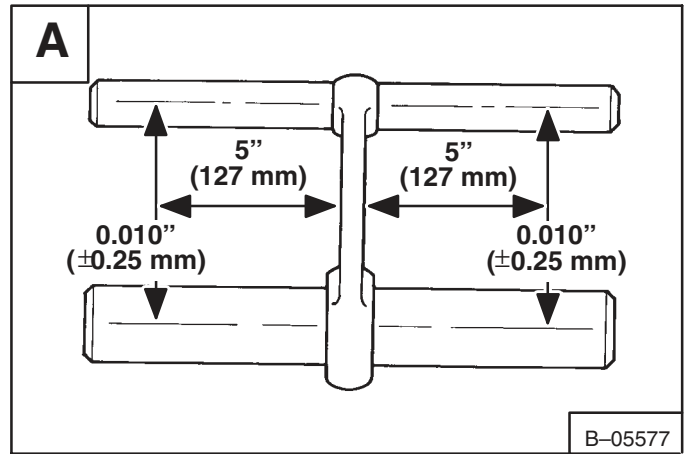

ENGINE OIL COOLER

Removal and Installation

Remove the bolt and nut (Item 1) [A] that hold the low-pressure fuel pipes to the top of the cooler.

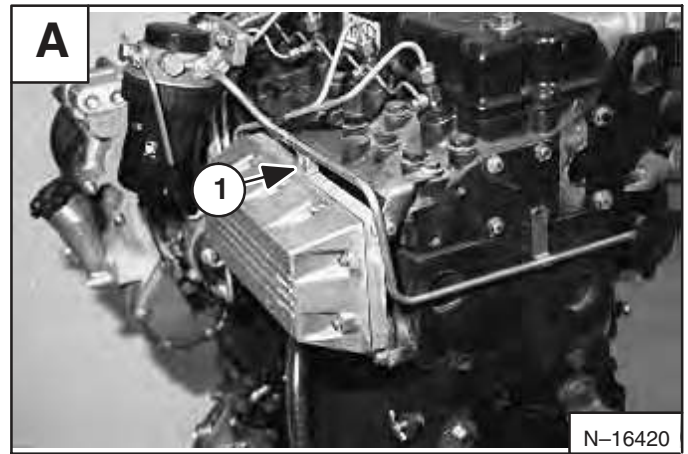

Remove the support bracket (Item 1)[B] for the oil cooler

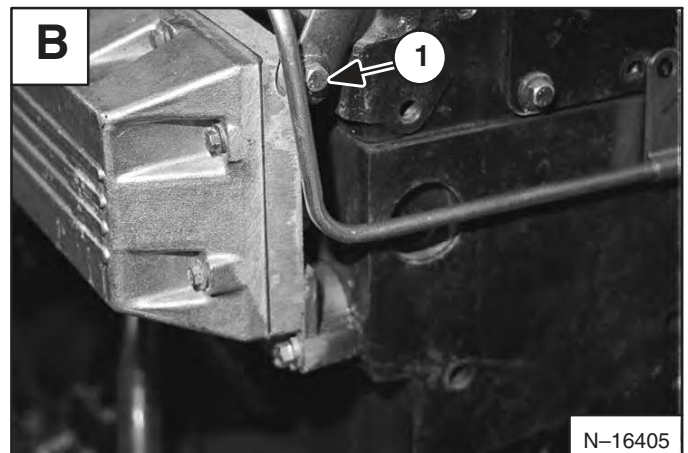

Loosen the hose clamp (Item 1) [C] at the front of the oil cooler.

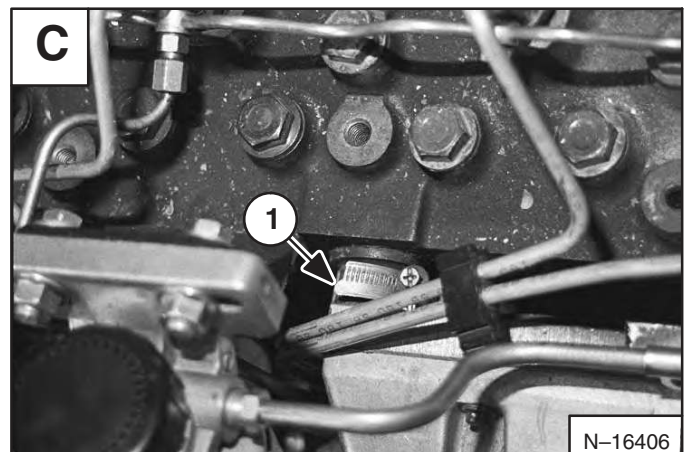

Remove the front cooler mounting bolt (Item 1) [D].

Remove the cooler mounting bolts (Item 2) [D].

Installation: Tighten the mounting bolts to 16 ft.-lbs. (22 Nm) torque.

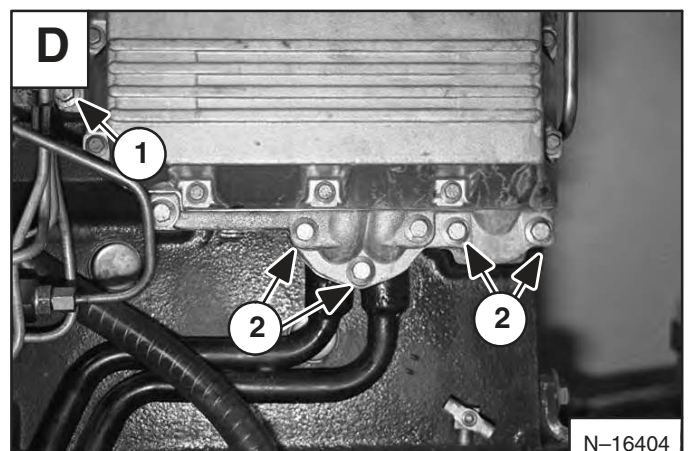

ENGINE BLOCK (Cont'd)

Cylinder Liner Inspection

The condition of a cylinder liner is decided by:

- The amount and location of polished areas.
- Wear.
- Damage to the liner wall.

NOTE: It is not necessary to replace the liners if: The honed finish can be clearly seen. Engine performance and oil consumption is acceptable.

Examine the liner surface (Item 1) [A] for cracks, deep scratches and polished areas where the honed finish is worn away.

Check the cylinder liner bore for out of round or wear beyond service limits [B]. The inside diameter of the service liner should be 3.937–3.939 inch (100,00–100,06 mm).

A flex type hone may be used to clean up small scoring or pitting.

Damaged or worn liners must be replaced.

Cylinder Liner Removal

NOTE: Where several liners are to be removed or a very tight production liner is found, a press should be used.

When one liner is replaced, a hand tool is available and the following procedure can be done with the crank shaft installed.

Rotate the crankshaft (if installed) to provide access to the liner and protect the crank pin from damage.

Place the tool (Item 1)[C] over the center of the liner (Item 2) [C]. Make sure the flat bearing race (Item 3) [C] is against the bottom of the recess.

Install the rod (Item 4)[C] through the handle (Item 5)[C].

Place the adapter (Item 6) [C] under the cylinder liner . Tighten the nut and washer. Turn the handle and pull out the old liner.

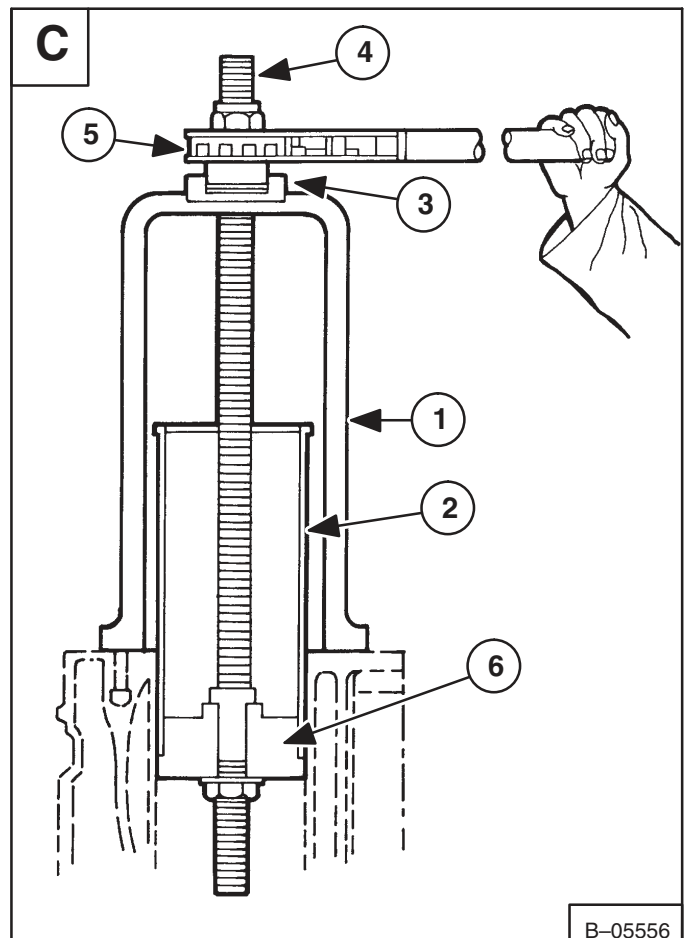
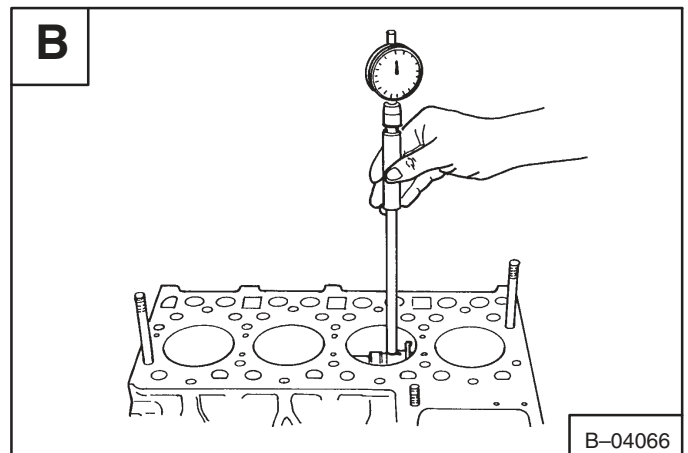
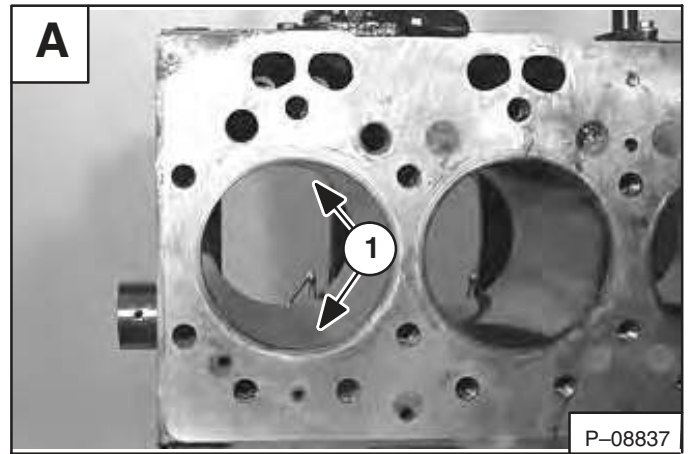

BICS™ (Without Press To Operate Button)

Inspecting The BICS™ Controller (Engine STOPPED – Key ON)

1. Sit in the operator's seat. Turn key ON, lower the seat bar and disengage the parking brake. All five BICS System Controller lights should be ON (Items 1, 2, 3, 4 & 5) [A].
2. Engage the parking brake and raise the seat bar fully. Seat bar light (Item 2)[A], valve light (Item 3)[A] and traction light (Item 4) [A] should be OFF.
3. Raise up slightly off the seat. Seat light (Item 1) [A] should be OFF.

NOTE: Record what lights are blinking (if any) and number of blinks. Refer to Page 8–6.

4. Exit the loader and press traction lock override button. Traction light (Item 4) [A] should be ON. Press override button again and traction light (Item 4) [A] should be OFF.

Inspecting Deactivation of the Auxiliary Hydraulics System (Engine STOPPED – Key ON)

5. Sit in the operator's seat. Lower the seat bar. Press the auxiliary hydraulics mode switch. The mode switch light will come ON. Raise the seat bar. The light should be OFF.

Inspecting the Seat and Seat Bar Sensors (Engine RUNNING)

6. Sit in the operator's seat. Lower the seat bar. Engage the parking brake. Fasten the seat belt.
7. Start the engine and operate at low idle. While raising the lift arms, raise the seat bar fully. The lift arms should stop. Repeat using the tilt function.

Inspecting the Traction Lock (Engine RUNNING)

8. Fasten the seat belt, disengage the parking brake, and raise the seat bar fully. Move the steering levers slowly forward and backward. The traction lock should be engaged. Lower the seat bar.
9. Engage the parking brake pedal and move the steering levers slowly forward and backward. The traction lock should be engaged.

Inspecting the Lift Arm By-Pass Control

10. Raise the lift arms six feet (2 m) of the ground. Stop the engine. Turn the Lift Arm By-Pass Control Knob clockwise 1/4 turn. Then pull up and hold the Lift Arm By-Pass Control Knob until the lift arms slowly lower.

Maintenance

Clean any debris, dirt or objects from under or behind the operator seat [B] & [C]. The rear of the seat must move up and down.

Inspect both seat rail covers [C] for wear or damage. Replace if necessary.

Clearance is necessary under the seat spring (Item 1)[C] and the seat, to allow the seat to move up and down freely. With adequate clearance, the seat sensor will be allowed to function correctly.

Inspect seat bar pivot area for tightness of linkage bolts.

Replace parts that are damaged. Use only genuine Bobcat replacement parts.

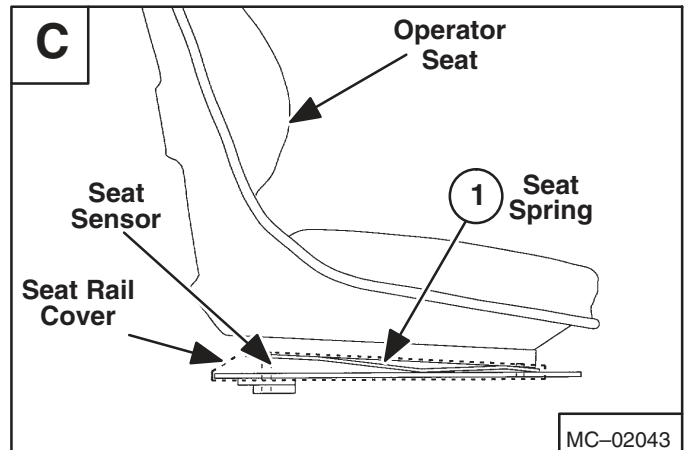
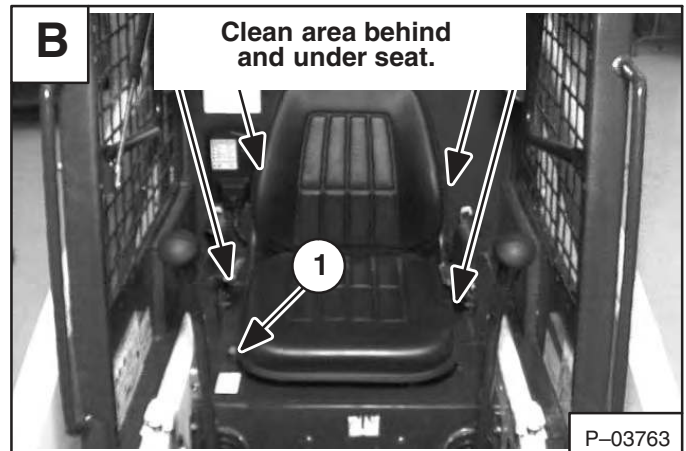
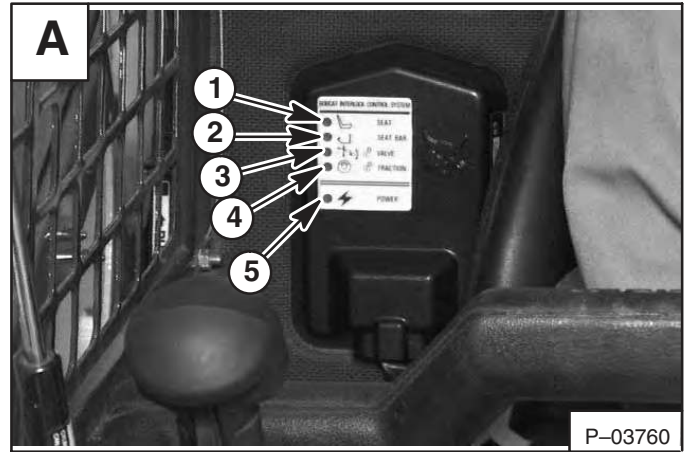

!

WARNING

AVOID INJURY OR DEATH

The Bobcat Interlock Control System (BICS™) must deactivate the lift, tilt and traction drive functions. If it does not, contact your dealer for service. DO NOT modify the system.

W-2151-0394

SEAT SENSOR (Cont'd)

Removal and Installation

Raise the operator cab. (See Page 1-1.)

Locate the seat sensor (Item 1) [A] beneath the operator cab.

Remove the sensor connector (Item 1) [B] from the holder.

Disconnect the sensor connector (Item 1) [B].

Remove the magnet collar mounting bolt (Item 2) [B], washer (Item 1) [C] and magnet (Item 2) [C] from the sensor (Item 3) [B].

Remove the sensor mounting bolt (Item 4) [B] and nut.

IMPORTANT

DO NOT overtighten the magnet mounting bolt to prevent damage to the magnet.

I-2089-1095

IMPORTANT

Be careful to not overtighten the sensor mounting bolt and nut to prevent breakage of the sensor.

I-2088-1095

Remove the sensor (Item 3) [C].

NOTE: Be sure not to lose the magnet collar alignment pin (Item 4) [C] which is located in the sensor (Item 3) [C] when removing the sensor.

Remove the threaded bushing (Item 5) [C] from the seat track mounting bolt (Item 1) [D].

Inspect all parts for damage and wear and replace if necessary.

Reverse the removal procedure to install the seat sensor

Refer to Page 5-1 for seat removal and installation procedure.

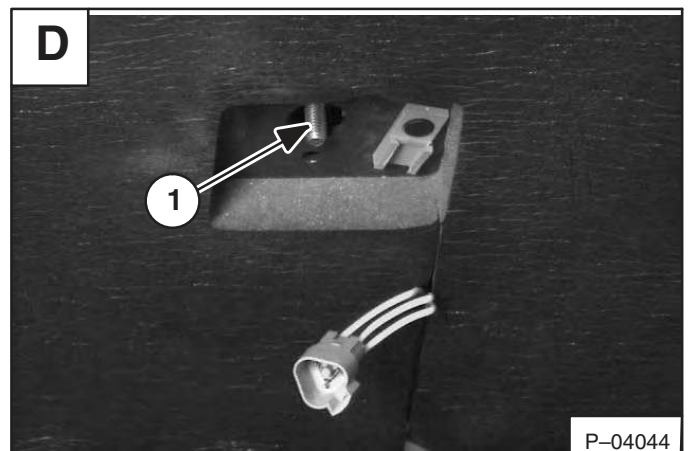
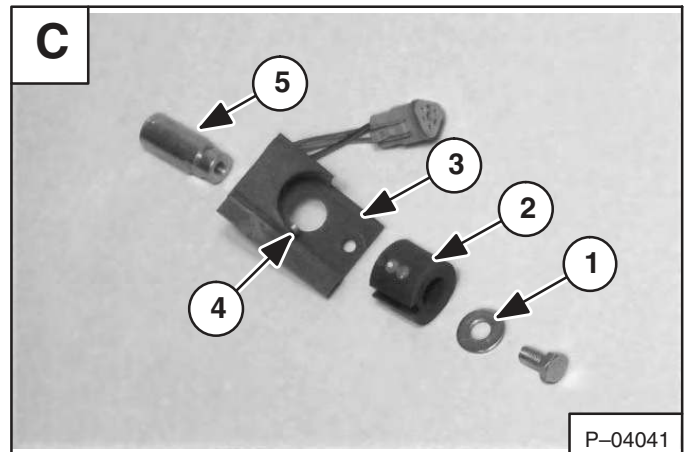
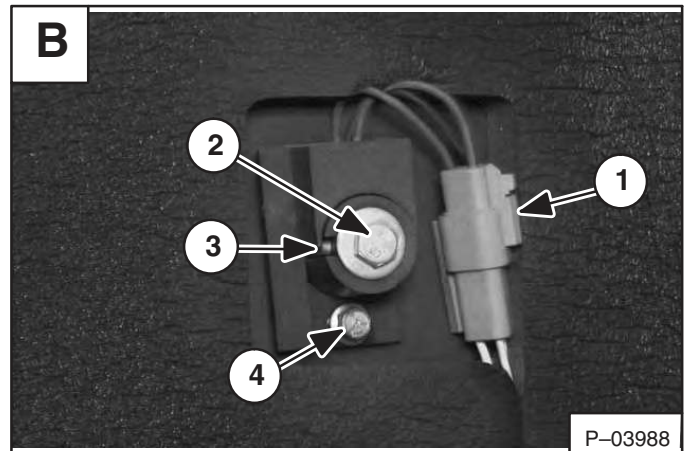
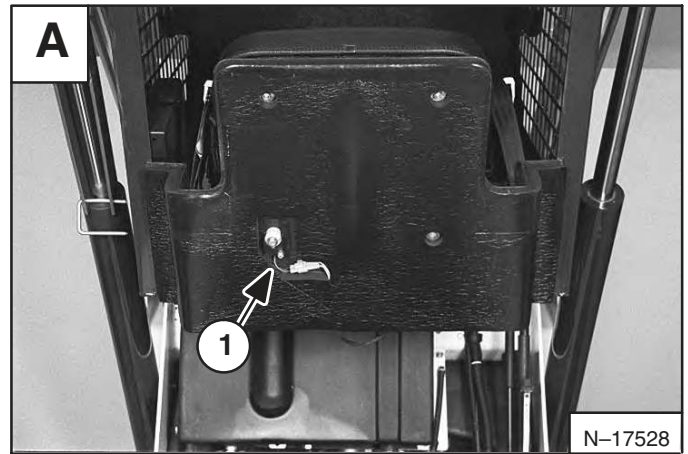

PWM MODULE (Cont'd)

Description (Cont'd)

- Take voltage measurements by probing into wires near the PWM module. All connectors must remain plugged into their respectful harness
- Sit in the operator's seat. Turn key to *ON* position. Lower the seat bar. Check that the BICS™ controller lights are on. Check input voltage (Item 1) **[A]**. Press the auxiliary hydraulics mode switch. The mode switch light will come *ON*. Raise the seat bar. The light should be *OFF*. Input voltage will drop to less than 1.0 volts.

NOTE: Item descriptions are listed below as Input to or Output from the Module. Voltage readings are approximate. They are affected by battery condition (system voltage).

Fig. [A]:

Item	Description	Volts
1	Input from BICS™ Auxiliary Deactivation	12.0
2	For future use	
3	For future use	
4	For future use	

PWM TROUBLESHOOTING

Conditions

- Auxiliary Hydraulic Switch lights will not come ON. Check the following:
 - PWM fuse
 - Wires disconnected, shorted, or cut.
 - Auxiliary hydraulic switch failure.
 - Module failure.Use the voltage tests in the wire identification section to determine the cause.
- Auxiliary Hydraulic Switch lights are flashing. See the troubleshooting chart. (See Page 8–25.)

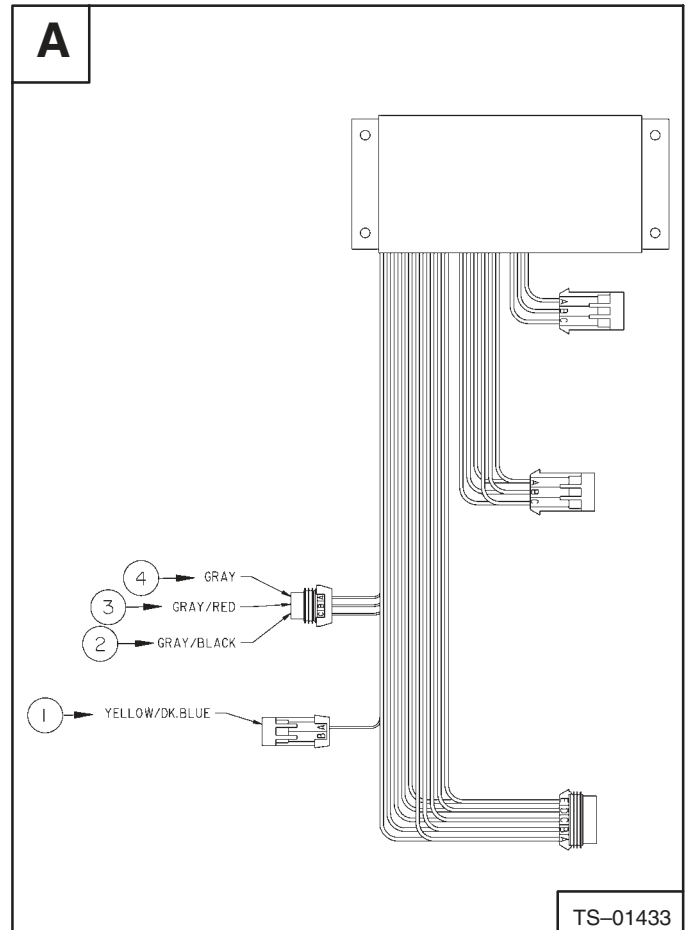

ENGINE SPECIFICATIONS (Cont'd)

All dimensions are given in inches. Respective metric dimensions are given in millimeters enclosed by parentheses.

Crankshaft (Cont'd)

Undersize Journals And Crank Pins 0.010 (0,25), 0.020 (0,51), 0.030 (0,76)

With the crankshaft on V-blocks check the maximum run-out of the journals. They must not exceed these specifications below and the difference in run-out between journals must not exceed 0.004 (0,10)

Journal #1	Mounting
Journal #2003 (0,08)
Journal #3006 (0,15)
Journal #4003 (0,08)
Journal #5	Mounting

Crankshaft Re-Grind Data

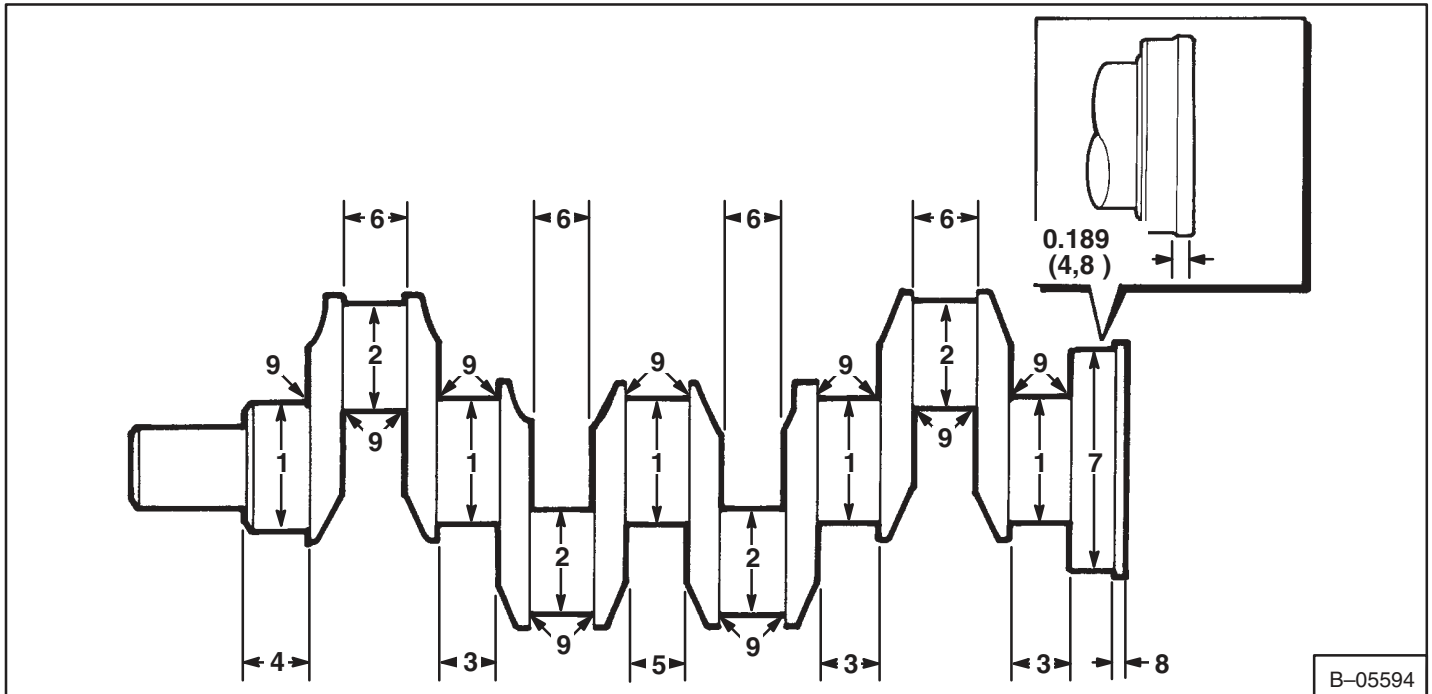

The finished sizes for crankshaft journals which have been ground undersize are given in the table below:

Item	0.010 (0,25)	0.020 (0,51)	0.030 (0,76)
1	2.9884–2.9892 (75,905–75,926)	2.9784–2.9792 (75,651–75,672)	2.9684–2.9692 (75,397–75,418)
2	2.4888–2.4896 (63,216–63,236)	2.4788–2.4796 (62,962–62,982)	2.4688–2.4696 (62,708–62,728)
3	1.554 (39,47) maximum	–	–
4	1.489 (37,82) maximum	–	–
5	1.759 (44,68) maximum	–	–
6	1.596 (40,55) maximum	–	–
7	5.243 (133,17) maximum	–	–
8	Do not machine this diameter	–	–
9	0.145–0.156 (3,68–3,96)	–	–

Crankshaft Heat Treatment: 60 Hour Nitride

NOTE: Crankshafts that have been nitrided for 60 hours can be machined 0.010 (0,25) without the need to harden again. Check the crankshaft for cracks before and after machining. Demagnetize the crankshaft after it has been checked for cracks. Remove any sharp corners from the oil holes. Surface finish and fillet radii must be maintained.

HYDRAULIC CONNECTION SPECIFICATIONS (Cont'd)

O-ring Flare Fitting (Cont'd)

NOTE: O-ring flare fittings are not recommended in all applications. Use the standard flare fittings in these applications.

Do not use a O-ring flare fitting when a copper bonnet orifice is used. When tightened the connection at the bonnet may distort the flare face and prevent it from sealing.

Use a standard flare fitting (Item 1) [A] as shown.

When a O-ring flare fitting is used as a straight thread port adapter the O-ring flare face is not used to seal. The O-ring may come off the fitting and enter the system.

Always remove the O-ring (Item 1) [B] from the flare face as shown.

An O-ring (Item 2) [B] is added to the flat boss of the fitting to seal the connection in this application.

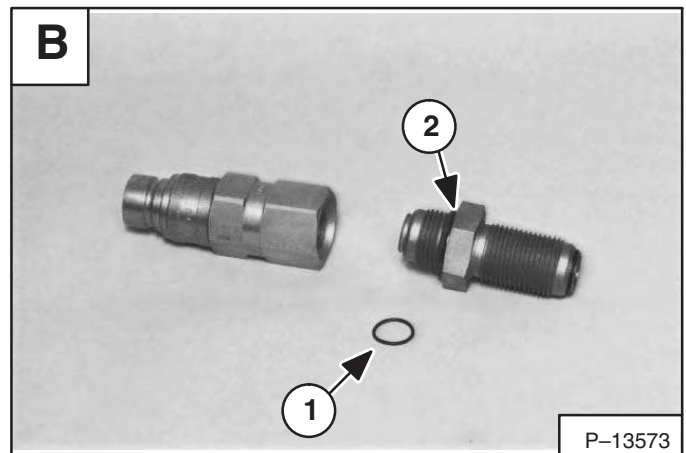
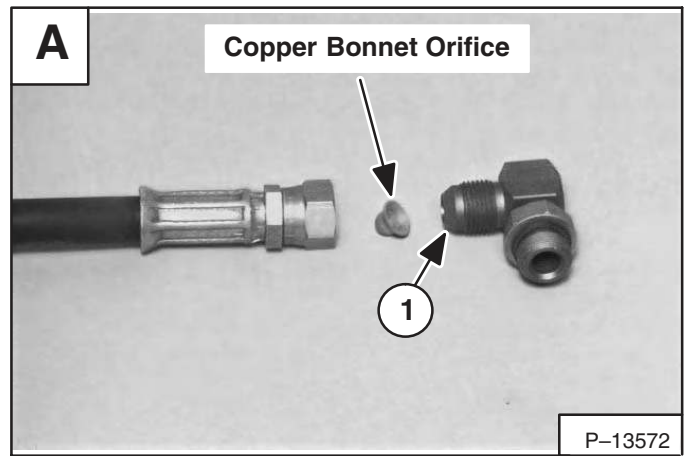

ACTUATOR VOLTAGE TEST (Cont'd)

Procedure (Cont'd)

Diagnosis Results For Tilt Actuator (top) Sensor Supply Voltage Test;

If the sensor supply voltage is 4.3 ± 0.1 volts, continue on and check the signal voltage.

If the sensor supply voltage is less than 4.3 ± 0.1 volts or 0 volts, check the PWM fuse, check for shorts or opens in the wiring harness. If there are no apparent shorts or opens change the AHC/PWM controller. (See Page 10–13.)

If the sensor supply voltage is more than 4.3 ± 0.1 volts check for a short of the power wires in the wiring harness. If there are no apparent shorts change the AHC/PWM controller. (See Page 10–13.)

Diagnosis Results For Tilt Actuator Signal Voltage Test;

If the signal voltage is in the range of 1.55 to 1.85 volts, the system is functioning properly. The nominal voltage reading is 1.72 volts.

If the signal voltage is not in the range of 1.55 to 1.85 volts check the hydraulic control valve spools for a centering problem or replace the actuators. (See Page 10–27.)

Handle Out (Toward Side Screen):

1. Stop engine. Raise operator cab.
2. Connect the remote start switch (MEL1429A) to the loader.
3. Turn key to ON position with engine OFF to get a code indication from the indicator lights on the left control handle.
4. Check the sensor supply voltage. (See Page 10–6.)
5. Check the system to make sure it is functional, with no blinking indicator lights.
6. Move right AHC handle toward the side screen to full stroke. Hold in position and take a voltage reading.
The voltage reading must be 0.13 volts or greater.
If the voltage reading is less than 0.13 volts, replace the actuator. (See Page 10–27.)
While holding the handle toward the side screen turn the key to OFF position and wait five seconds..
7. Continue to hold the handle toward the side screen and turn the key to the ON position. Take a voltage reading.
(*You will have a one blink alarm on the right indicator light.*)
The voltage reading should be between 1.55 to 1.85 volts.
If the voltage is above 1.85 volts, repeat steps 5 thru 7, if the voltage is still above 1.85 volts change the actuator.
If the voltage is below 1.55 volts complete the following tests: (See Step 11 Below; Tests **a** & **b**.)

Handle In (Toward Center Of Cab):

8. Turn the key to OFF position and wait five seconds, then turn key to ON position. Check the system to make sure it is functional, with no blinking indicator lights.
9. Move right AHC handle toward the center of the cab to full stroke. Hold in position and take a voltage reading.
The voltage reading must be 3.2 volts or less.
If the voltage reading is more than 3.2 volts, check for shorts in the electrical connections, or replace the actuator. (See Page 10–27.)
10. While the handle is held toward the center of the cab, turn the key to OFF position and wait five seconds.
11. Continue to hold the handle toward the center of the cab and turn the key to the ON position and take a voltage reading.
(*You will have a one blink alarm on the right indicator light.*)
The voltage reading should be between 1.55 to 1.85 volts.
If the voltage is below 1.55 volts, repeat steps 8 thru 11 if the voltage is still below 1.55 volts change the actuator.
If the voltage is above 1.85 volts complete the following tests:
 - a.** Remove the pin from the actuator to the control spool. Watch the spool, if the spool continues to move toward neutral after the pin is removed, replace the actuator. Also check the mounting hardware on the actuators and control valve for wear and correct torque.
 - b.** If the spool does not move, check the control valve for a sticky spool or sticky centering mechanism. Also check the mounting hardware on the actuators and control valve for wear and correct torque.

HANDLE CONTROL UNIT

Removal And Installation

To remove the handle control unit, slide the rubber handle cover (Item 1) [A] up the handle.

Remove the two mounting bolts (Item 2) [A] from the control cover.

Remove the control cover.

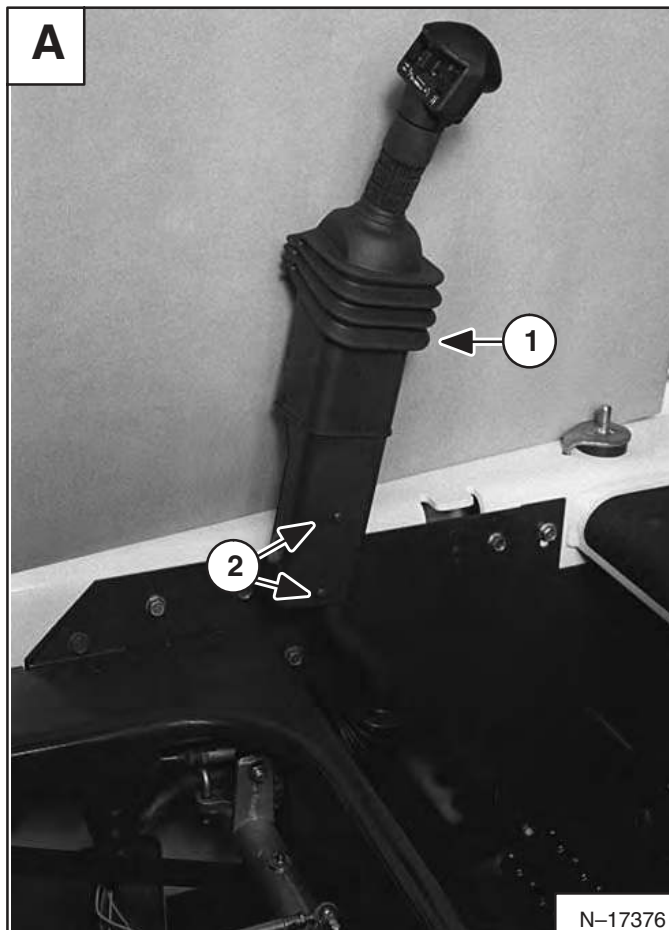

Disconnect the loader control harness (Item 1) [B] from the handle control harness.



A.H.C. STEERING LEVER

Removal and Installation

Remove the handle control unit. (See Page 10–17.)

Remove the switch handle from the steering lever. (See Page 10–21.)

Remove the handle from the steering lever. (See Page 10–24.)

Loosen the two u-clamps (Item 1) [A] nuts.

Remove the steering lever from the cross shaft and control panel.

The steering lever (Item 1) [B] must be replaced as a complete unit.

The connector clip (Item 2) [B] can be replaced separately from the steering lever.

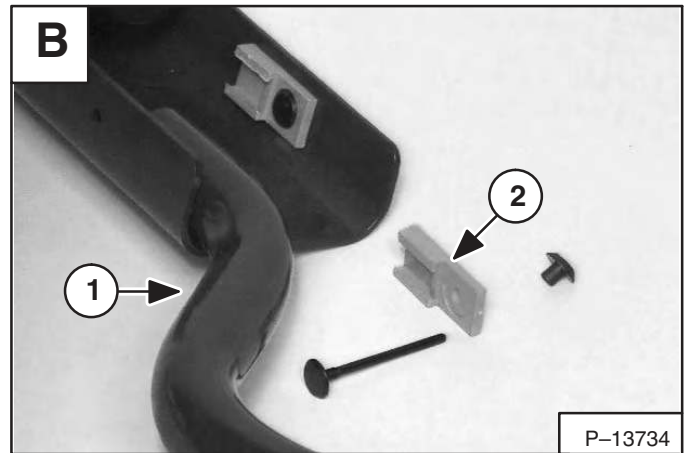
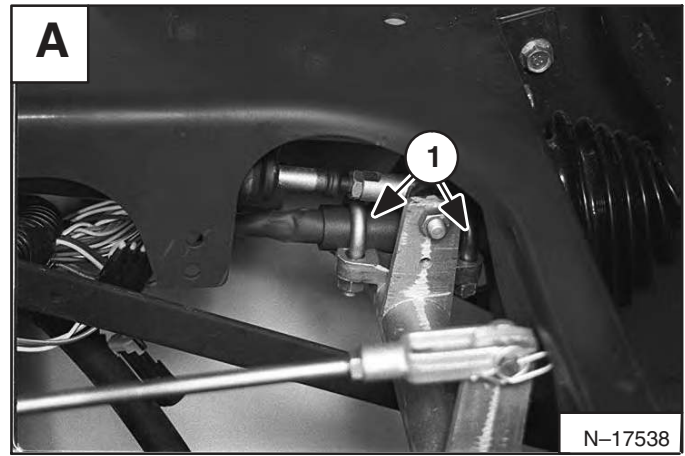

Steering Lever Boot

Disconnect the switch handle harness connectors from the loader wiring harness connectors. (See Page 10–22.)

Remove the connectors from the switch handle wiring harness. (See Page 10–22.)

Loosen the two u-clamps (Item 1) [A] and remove the steering lever.

Remove the four pop rivets from the boot retainer (Item 1) [C] and control panel.

Remove the steering lever boot.

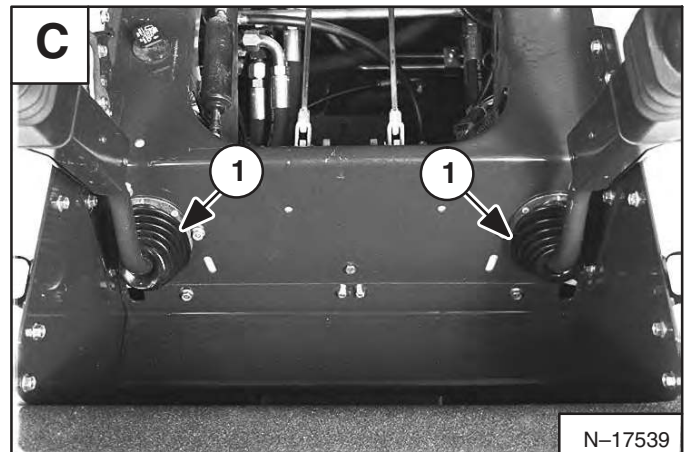

HYDRAULIC CONTROL VALVE (Cont'd)

Disassembly and Assembly

Remove the BICS valve assembly from the control valve. (See Page 10-32.)

Remove the four large O-rings (Item 1) [A] and small O-ring (Item 2) [A]. Always replace these O-rings before installing the BICS valve assembly.

The anti-cavitation valve, port relief valves and plugs are at different locations in the control valve. Refer to Control Valve Identification Chart for the correct location of the parts. (See Page 10-36.)

IMPORTANT

When making repairs on hydrostatic and hydraulic systems, clean the work area before disassembly and keep all parts clean. Always use caps and plugs on hoses, tubelines and ports to keep dirt out. Dirt can quickly damage the system.

I-2003-0284

Mark each valve section, spool and related parts so that they will be returned to its original valve location during assembly.

Load Check Valve

Loosen the load check valve plug (Item 1) [B].

Installation: Always use new O-ring. Tighten the plug to 35-40 ft.-lbs. (47-54 Nm) torque.

Remove the load check plug (Item 1) [C].

Remove the spring (Item 2) [C] and poppet (Item 3) [C].

The auxiliary section (Item 2) [B] uses an orifice load check poppet.

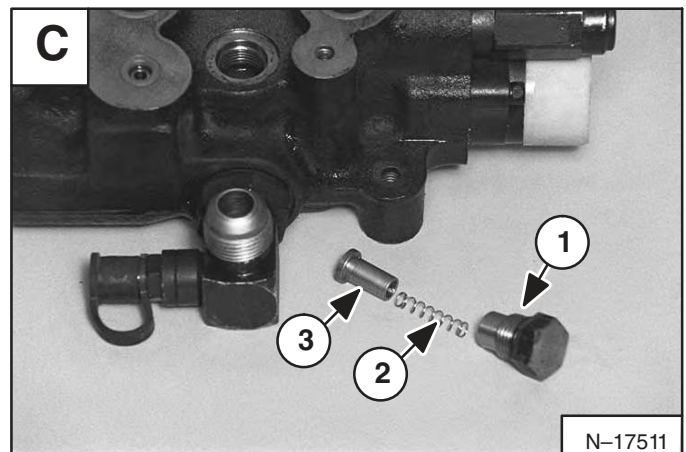
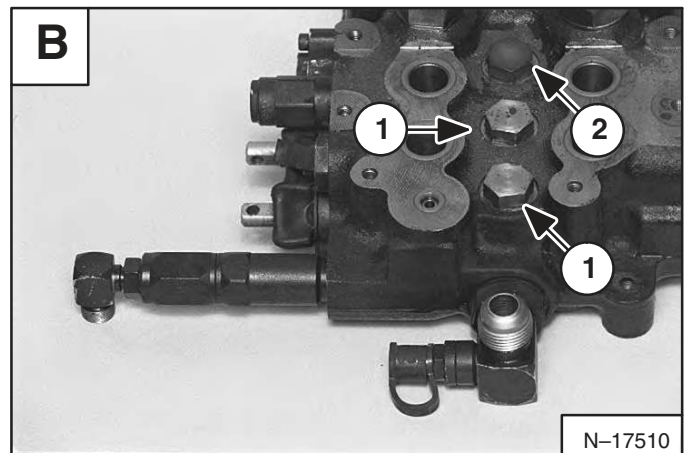
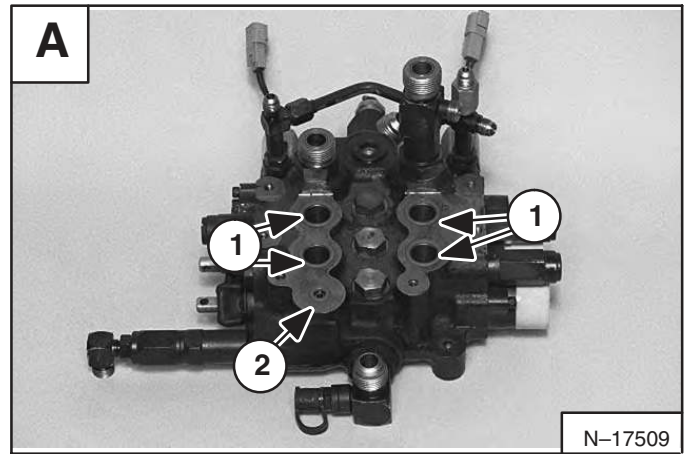

HYDRAULIC CONTROL VALVE (Cont'd)

H-Port Auxiliary Section

Loosen the plug (Item 1) [A].

Installation: Tighten the plug to 35–40 ft.-lbs. (47–54 Nm) torque.

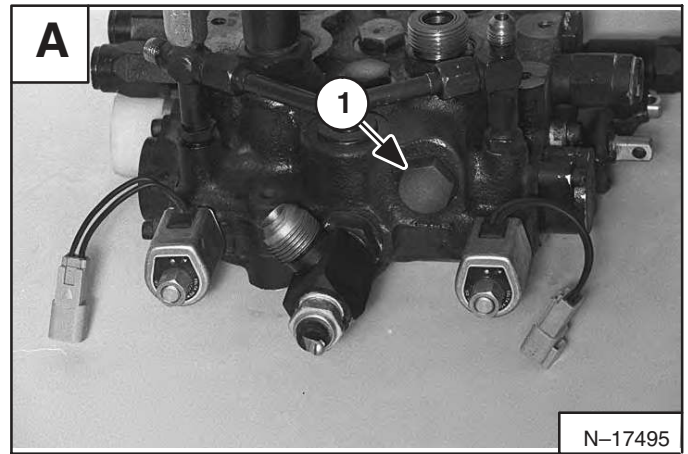

Remove the plug from the control valve [B].



Depending on the application of the auxiliaries, the control valve may be equipped with a port relief valve (Item [C]).

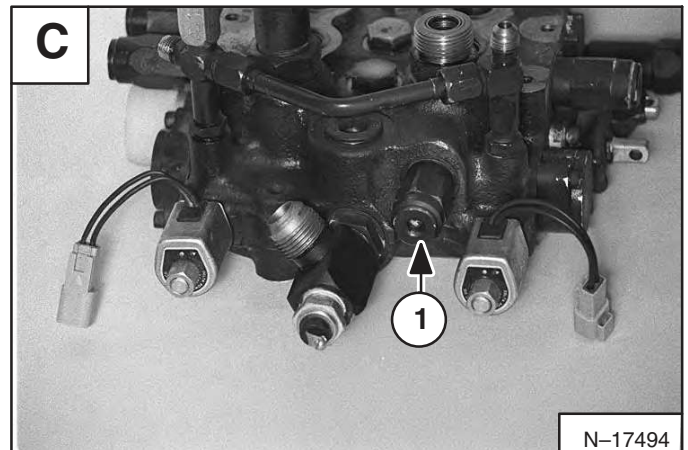

If so equipped, remove the port relief from the control valve [D].

Installation: Replace the O-rings and back-up washers. Tighten the port relief valve 35–40 ft.-lbs. (47–54 Nm) torque.



CLICK HERE TO **DOWNLOAD** THE COMPLETE MANUAL

- Thank you very much for reading the preview of the manual.
- You can download the complete manual from: www.heydownloads.com by clicking the link below



- Please note: If there is no response to **CLICKING** the link, please download this PDF first and then click on it.

CLICK HERE TO **DOWNLOAD** THE COMPLETE MANUAL