

8

7

3



# Service Manual

(S/N 514114999 & Below)  
(S/N 514212999 & Below)

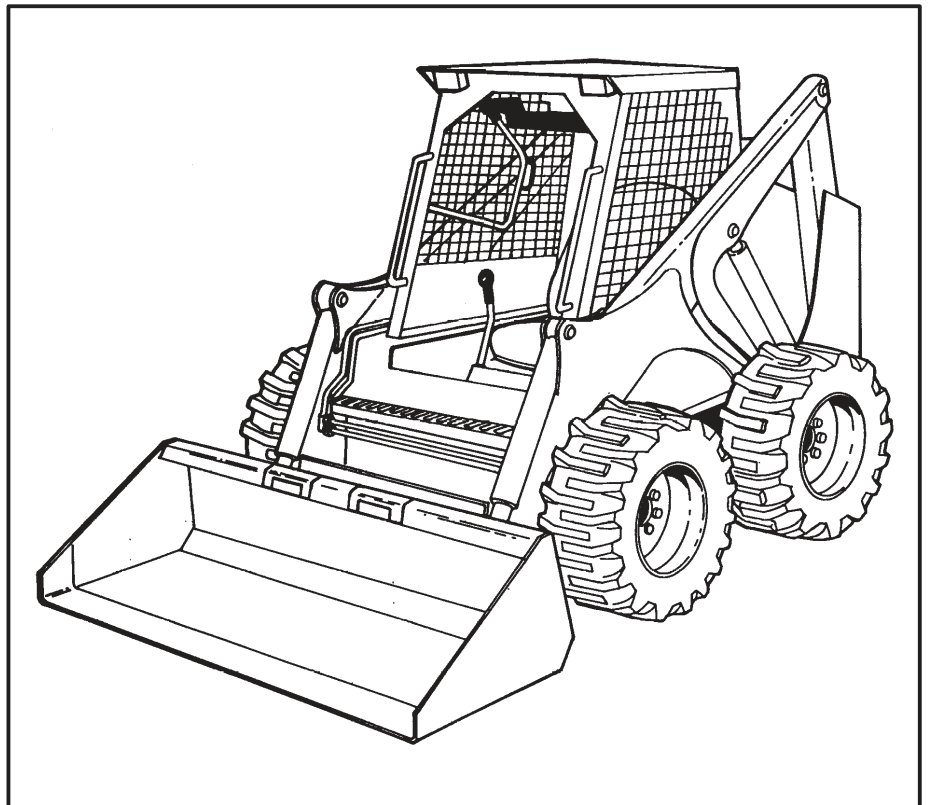

Dealer Copy -- Not for Resale

EQUIPPED WITH  
BOBCAT INTERLOCK  
CONTROL SYSTEM (BICS™)

6724280 (7-10)

Printed in U.S.A.

© Bobcat Company 2010

CLICK HERE TO **DOWNLOAD** THE COMPLETE MANUAL

- Thank you very much for reading the preview of the manual.
- You can download the complete manual from: [www.heydownloads.com](http://www.heydownloads.com) by clicking the link below



- Please note: If there is no response to **CLICKING** the link, please download this PDF first and then click on it.

CLICK HERE TO **DOWNLOAD** THE COMPLETE MANUAL

## SAFETY INSTRUCTIONS

# **WARNING**

Instructions are necessary before operating or servicing machine. Read Operation & Maintenance Manual, Handbook and signs (decals) on machine. Follow warnings and instructions in the manuals when making repairs, adjustments or servicing. Check for correct function after adjustments, repairs or service. Failure to follow instructions can cause injury or death.

W-2003-1289

The following publications provide information on the safe use and maintenance of the loader and attachments:

- The Delivery Report is used to assure that complete instructions have been given to the new owner and that the machine is in safe operating condition.
- The Operation & Maintenance Manual delivered with the loader gives operating information as well as routine maintenance and service procedures. It is a part of the loader and must stay with the machine when it is sold. Replacement Operation & Maintenance Manuals can be ordered from your Bobcat loader dealer.
- The loader has machine signs (decals) which instruct on the safe operation and care. The signs and their locations are shown in the Operation & Maintenance Manual. Replacement signs are available from your Bobcat loader dealer.
- The loader has a plastic Operator's Handbook fastened to the operator cab. Its brief instructions are convenient to the operator. The handbook is available from your dealer in an English edition or one of the following languages: French, German, Italian, Dutch, Spanish, Portuguese, Finnish, Danish & Swedish.
- The EMI Safety Manual (available in Spanish) delivered with the loader gives general safety information.
- The Service Manual and Parts Manual are available from your dealer for use by mechanics to do shop-type service and repair work.
- The Skid-Steer Loader Operator Training Course is available through your local dealer. This course is intended to provide rules and practices for correct operation of the Bobcat loader. The course is available in English and Spanish versions.

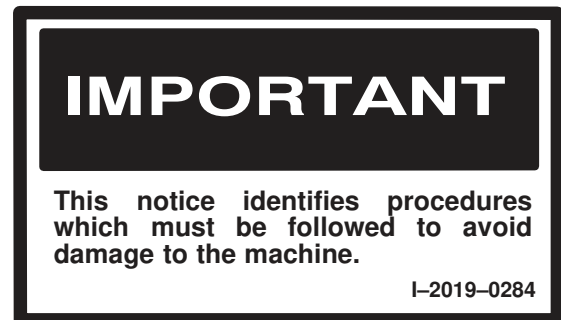

**Safety Alert Symbol:** This Safety Symbol is used for important safety messages. When you see this symbol follow the safety message to avoid personal injury or death.

## TRANSPORTING THE LOADER

### Procedure

# ! WARNING

Adequately designed ramps of sufficient strength are needed to support the weight of the machine when loading onto a transport vehicle. Wood ramps can break and cause personal injury.

W-2058-0494

A loader with an empty bucket or no attachment must be loaded backward onto the transport vehicle [A].

The rear of the trailer must be blocked or supported [A] when loading or unloading the loader to prevent the front end of the trailer from raising up.

Be sure the transport and towing vehicles are of adequate size and capacity.

Use the following procedure to fasten the Bobcat loader to the transport vehicle to prevent the loader from moving during sudden stops or when going up or down slopes [B].

Lower the bucket or attachment to the floor. Stop the engine. Engage the parking brake. Install chains at the front and rear loader tie down positions (Inset [B]). Fasten each end of the chain to the transport vehicle and tighten the chain with a chain tightener.

The Inset [B] shows the decal with attachment points for towing and tie down.

## TOWING THE LOADER

### Procedure

To prevent damage to the loader's hydrostatic system, the loader must be towed only a short distance at slow speed. (Example: Moving the loader onto a transport vehicle.)

The towing chain (or cable) must be rated at 1-1/2 times the weight of the loader (See *SPECIFICATIONS*, Page 9-1).

- Turn the key switch to ON and press the Traction Lock Override button.
- Tow the Bobcat at 2 MPH (3,2 km/hr.) or less for not more than 25 feet (7,6 meters).

If the electrical system is not functioning part of the brake system must be disassembled to move the loader. See *Traction Lock* removal and installation procedure. (See Page 8-1.)

## STOPPING THE BOBCAT LOADER

### Procedure

When the steering levers are moved to the neutral position, the hydrostatic transmission will act as a *service brake* and stop the loader.

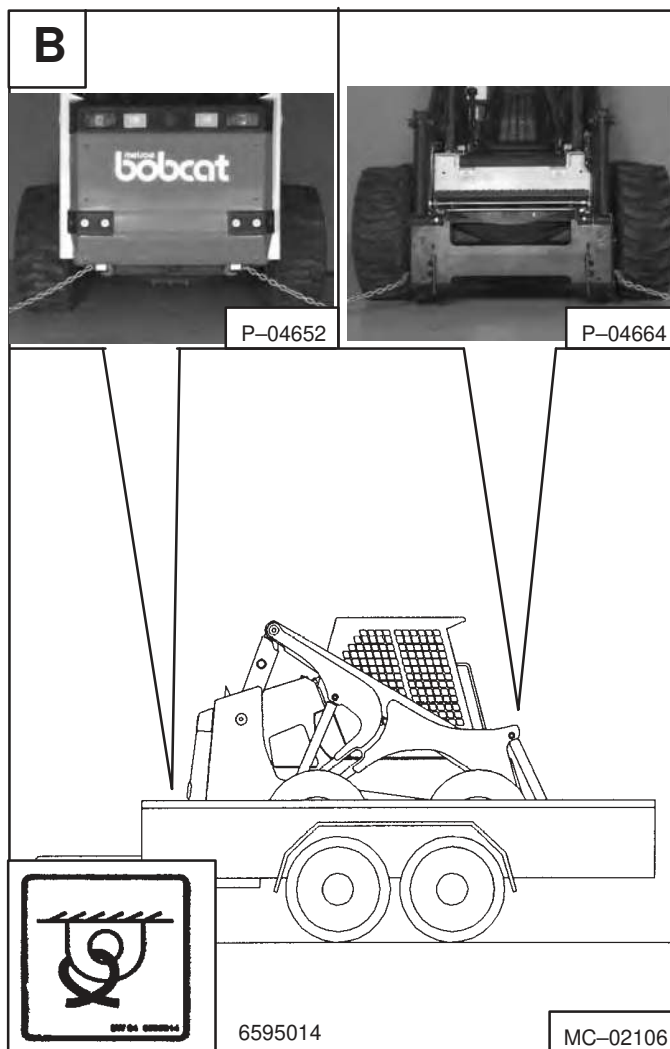
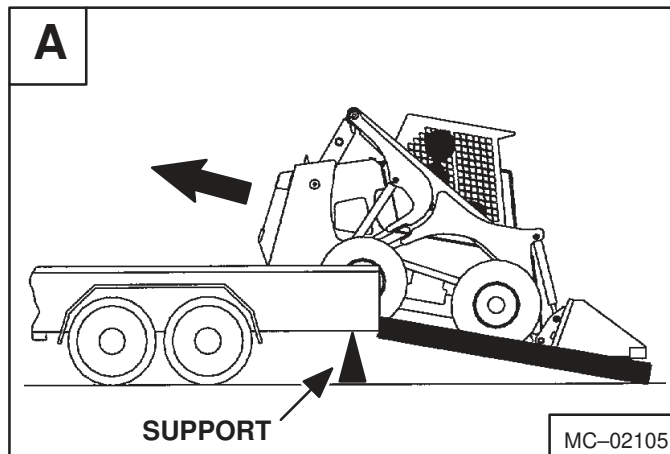

# IMPORTANT

Do not push or pull the machine at more than 2 MPH (3,2 km/h) or for a distance of more than 25 feet (7,6 meters) with the towing tool in place.

I-2017-0389

## ENGINE COOLING SYSTEM

Cleaning Cooling System (S/N 514111516-514114999)

Check the cooling system every day to prevent over-heating, loss of performance or engine damage.



### WARNING

Wear safety glasses to prevent eye injury when any of the following conditions exist:

- When fluids are under pressure.
- Flying debris or loose material is present.
- Engine is running.
- Tools are being used.

W-2019-1285

Remove the rear grill. (See Page 5-1.)

Use air pressure or water pressure to clean the top of the oil cooler [A].

Remove the cotter pin (Item 1) [B] (both sides) from the oil cooler.

Raise the oil cooler [C].

Use air pressure or water pressure to clean the top of the engine oil cooler.

**NOTE:** The access cover (both sides) must be in place to ensure proper air flow through the oil cooler which will ensure correct cooling for the enging/hydraulic system [D].

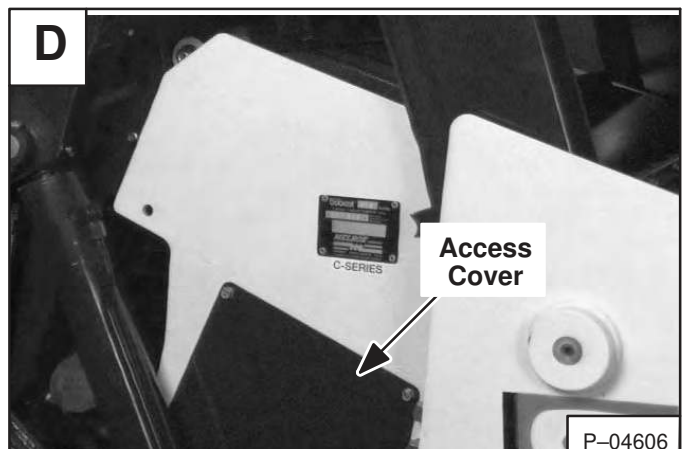
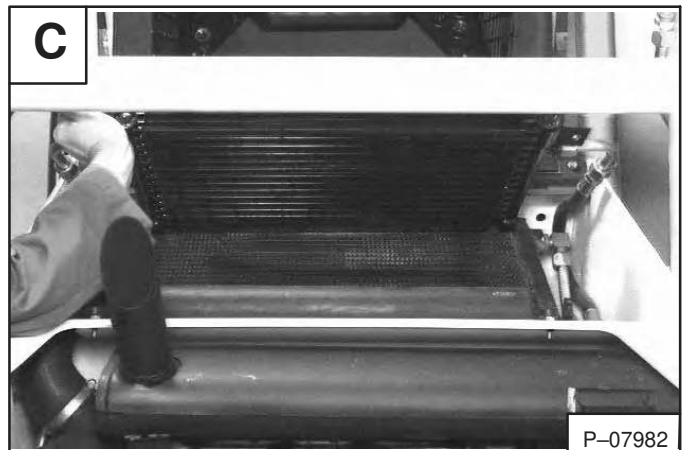
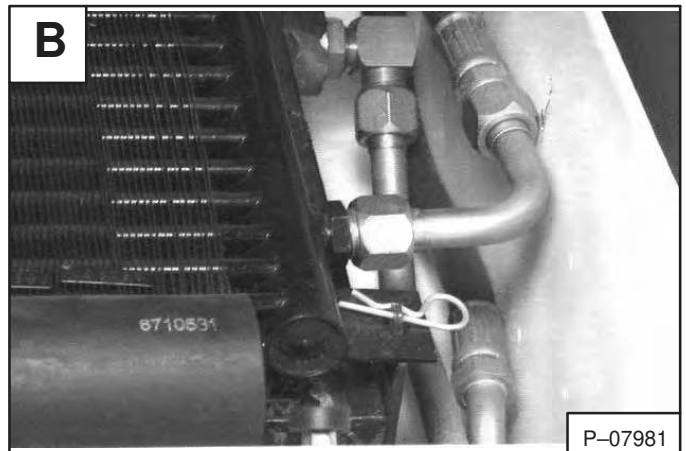
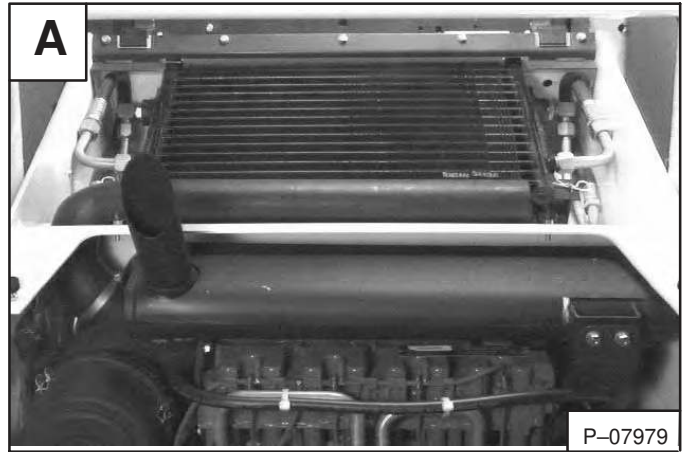

## REMOTE START SWITCH

### Procedure

The tool listed will be needed to do the following procedure:

MEL1429 – Remote Start Switch

The Remote Start Switch is required when the service technician is adjusting the steering linkage, checking the hydraulic/hydrostatic system.

Lift and block the loader. (See Page 1–4.)

Raise the lift arms and install an approved lift arm support device. (See Page 1–6.)

Raise the operator cab. (See Page 1–7.)

**NOTE: On current model loaders, the connector on the BICS harness is round (7-pin) connector, not a rectangular (8-pin) connector. Use the adapter harness (Item 1) [A] to connect the remote start switch to the loader harness.**

Disconnect the operator cab wire harness (Item 1) [A] from the engine wire harness.

Connect the remote start switch to the engine harness connectors (Item 1) [B].

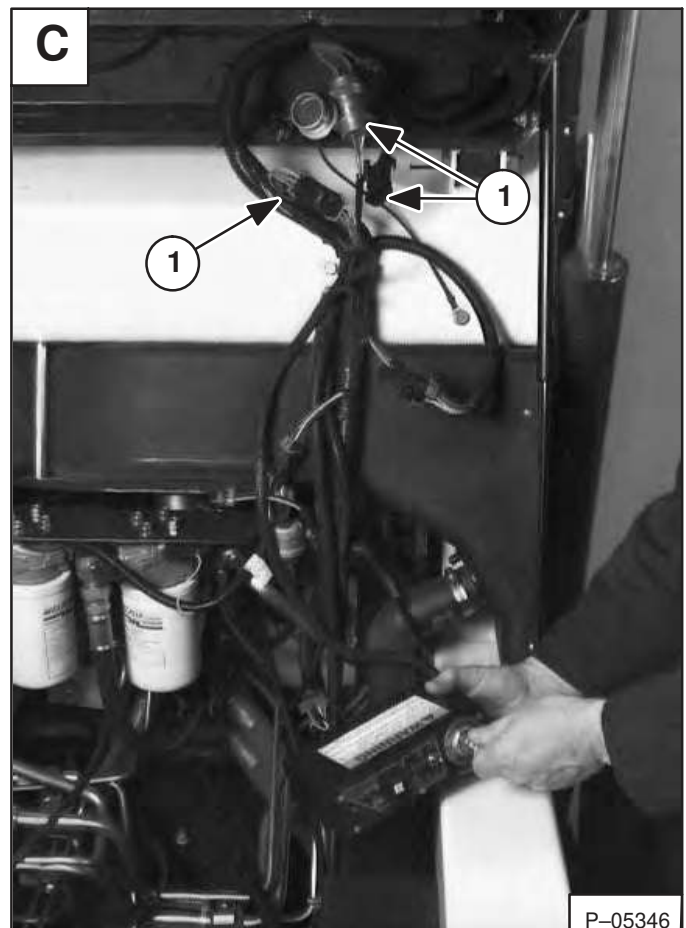
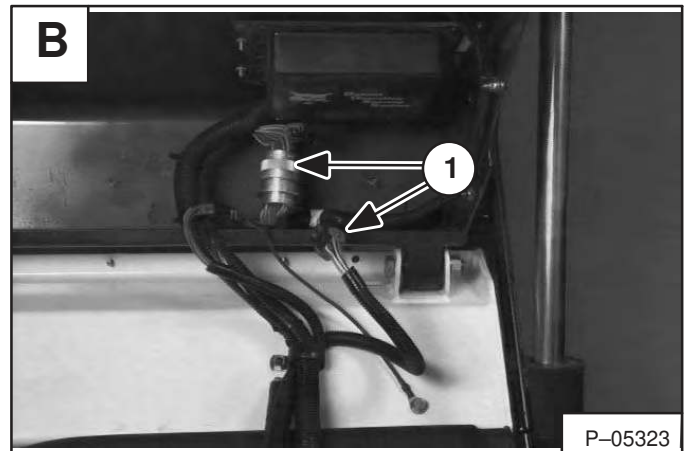
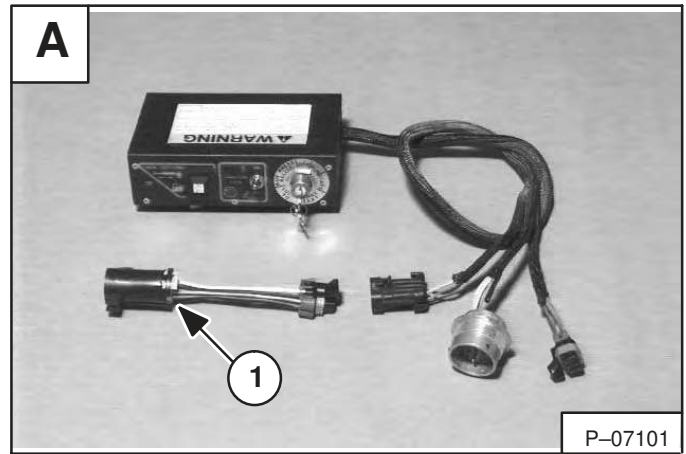

## WARNING

Put jackstands under the front axles and rear corners of the frame before running the engine for service. Failure to use jackstands can allow the machine to fall or move and cause injury or death.

W-2017-0286

## WARNING

Never work on a machine with the lift arms up unless the lift arms are secured by a lift arm support device. Failure to use an approved lift arm support device can allow the lift arms or attachment to fall and cause injury or death.

W-2059-0991

## LIFT CYLINDER(S)

### Checking The Lift Cylinder(s)

Lower the lift arms. Stop the engine. Raise the seat bar.



## WARNING

Hydraulic fluid escaping under pressure can have sufficient force to enter a person's body by penetrating the skin. This can cause serious injury and possibly death if proper medical treatment by a physician familiar with this injury is not received immediately.

W-2145-0290

Check only one cylinder at a time. Disconnect the hose (Item 1) [A] which goes to the base end of the lift cylinder.

Install a cap (Item 1) [B] on the fitting and tighten.

Engage the parking brake. Lower the seat bar. Start the engine and push the top (toe) of the lift pedal.

If there is any leakage from the hose end, remove the lift cylinder for repair. Repeat the procedure to check the other lift cylinder.

### Removal And Installation

Raise the operator cab. (See Page 1-1.)

Remove the retaining bolt and nut (Item 1) [C] from the retaining pin on the rod end of the cylinder.

**Installation:** Tighten the retainer bolt and nut to 18–20 ft.-lbs. (24–27 Nm) torque.

Remove the retaining pin (Item 1) [D] from the rod end of the cylinder.

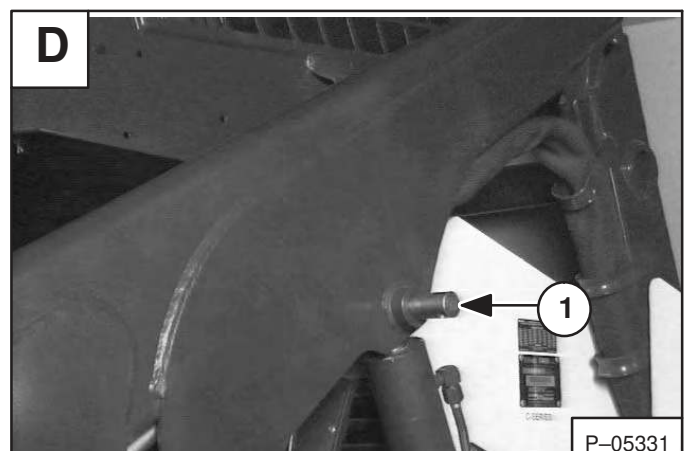
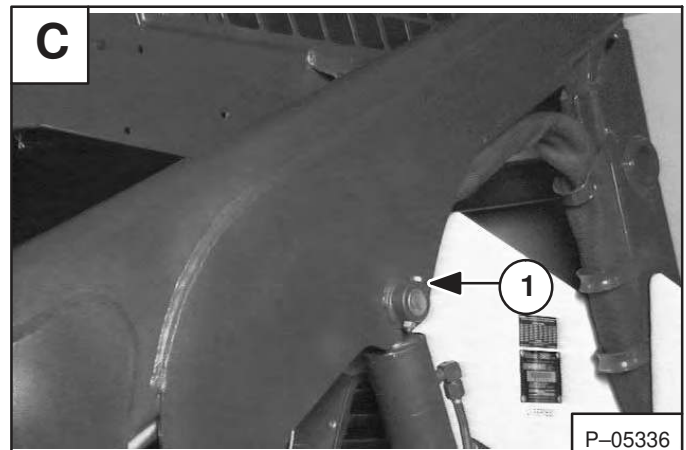
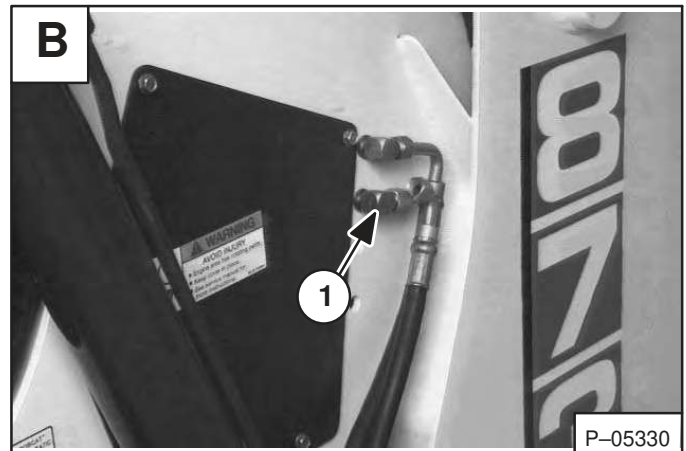
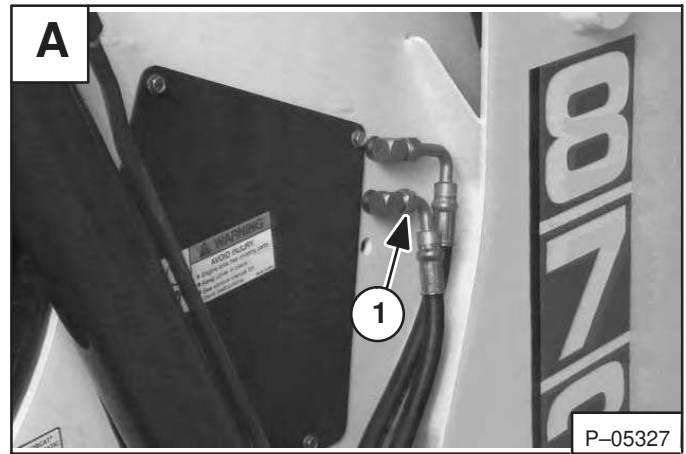

## HYDRAULIC CYLINDERS (Cont'd)

### Assembly (Cont'd)

Install the rod seal in the head [A].

Install the wiper seal with the wiper toward the outside of the head.



Install the thin O-ring (Item 1) [B].

Install the back-up washer (Item 2) [B] and thick O-ring (Item 3) [B] into the groove on the head.

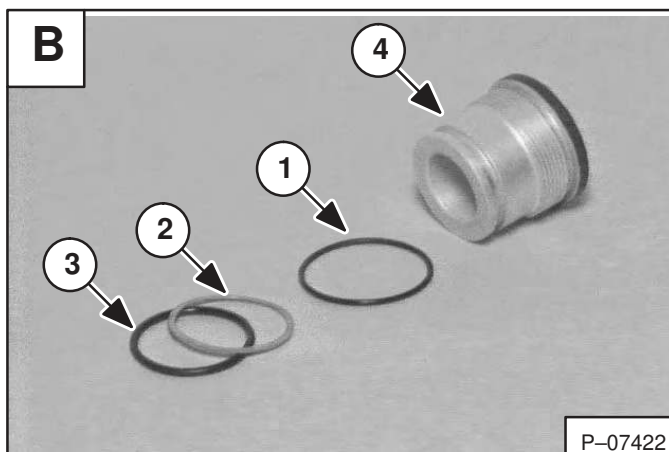

Lift Cylinder: Install the head (Item 4) [B], and spacer (Item 1) [C] on the cylinder rod.

Clean and dry the cylinder rod threads.

Grease the shoulder of the cylinder rod (Item 2) [C].

**NOTE: Grease must be applied to reduce friction and prevent galling. DO NOT GREASE CYLINDER ROD THREADS.**

Install the piston (Item 3) [C] with the chamfered side to the cylinder rod shoulder.

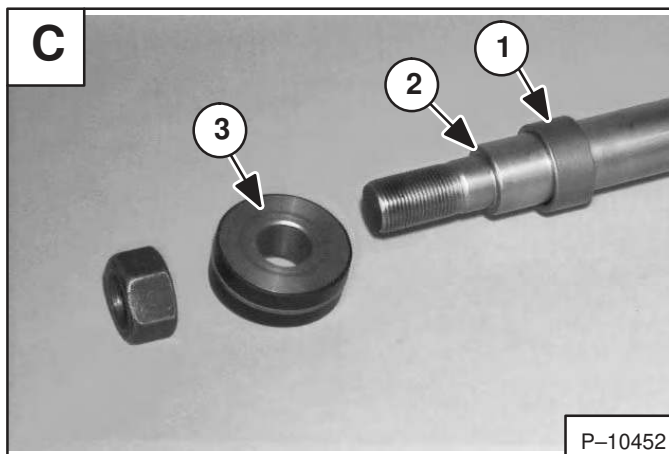

Grease the face of the piston (Item 1) [D] that comes in contact with the nut.

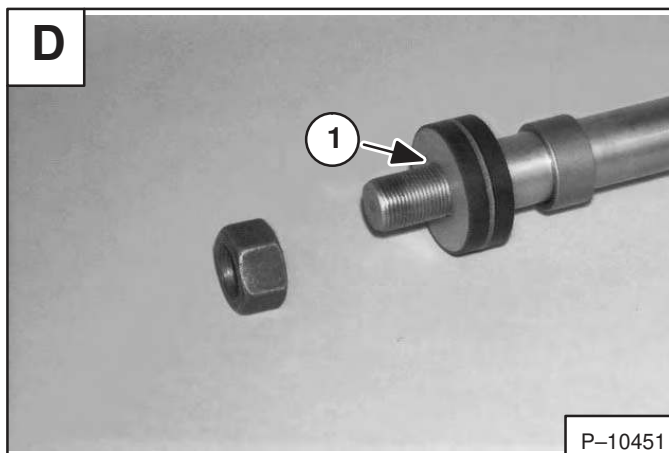

## HYDRAULIC CONTROL VALVE (Cont'd)

### Port Relief Valve (Cont'd)

Remove the port relief valve [A].

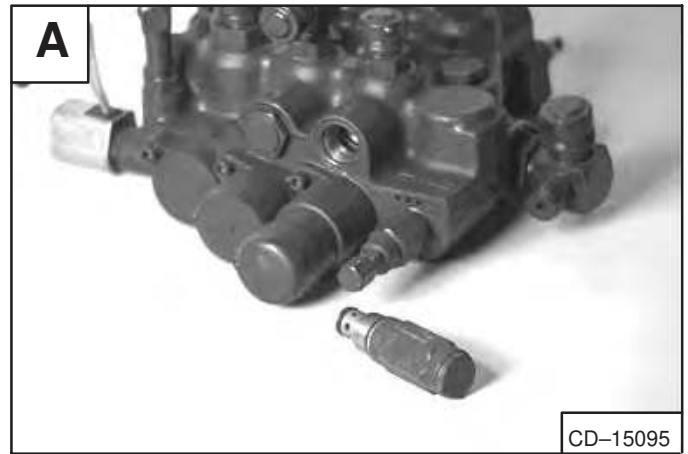

Remove the O-rings and back-up washer from the port relief valve [B].

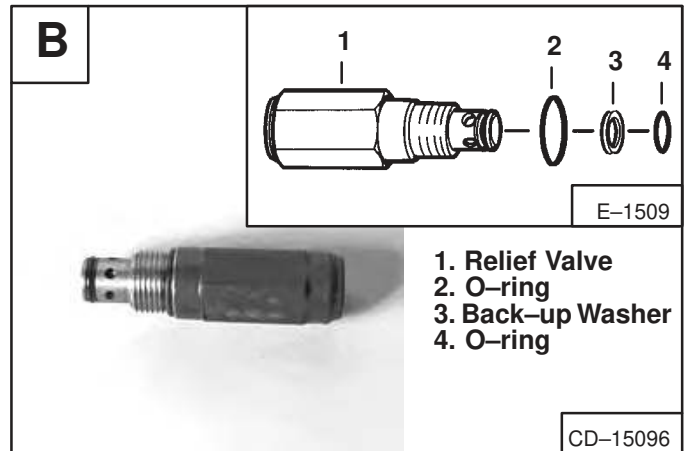

### Anti-Cavitation Valve

Loosen the anti-cavitation valve (Item 1) [C] (Port E2, or F2).

**Assembly:** Always use new O-rings and back-up washers. Tighten to 35–40 ft.-lbs. (47–54 Nm) torque.

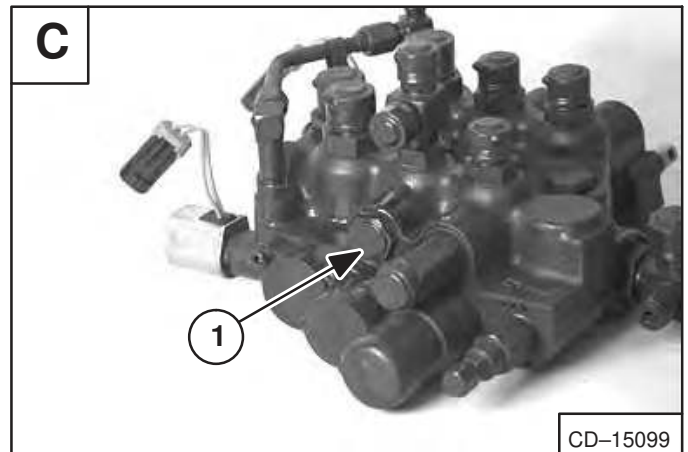

Remove the anti-cavitation valve from the control valve [D].



## HYDRAULIC CONTROL VALVE (Cont'd)

### H Port – Auxiliary Section

Loosen the plug (Item 1) [A].

**Assembly:** Tighten the plug to 35–40 ft.-lbs. (47–54 Nm) torque.

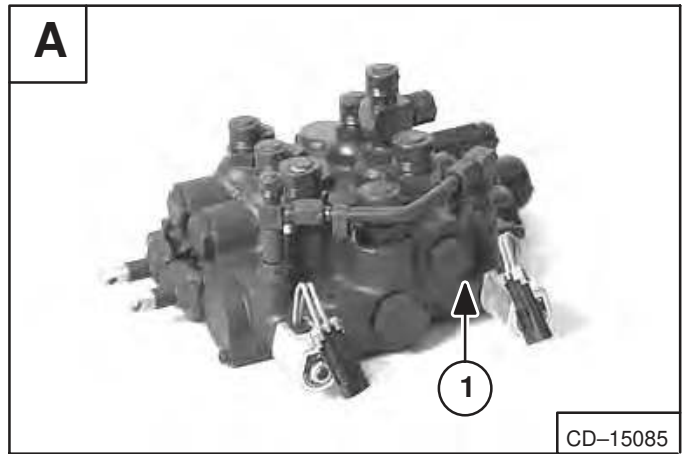

Remove the plug from the control valve [B].

Replace the O-ring.



Depending on the application of the auxiliaries, the control valve may be equipped with a port relief valve (H port).

Remove the port relief valve (Item 1) [C].

**Assembly:** Replace the O-rings and back-up washers. Tighten the port relief valve to 35–40 ft.-lbs. (47–54 Nm) torque.

### Base End Restrictor

Remove the adapter fitting (Item 1) [D] and remove the restrictor (Item 2) [D].

### Inspection

Check the spools for wear or scratches.

Check that the spools are not loose in their bore.

Check that the centering springs are not broken.

Check that the load check valve seats are not worn.

Check the load check poppets for damage.

Check the rubber boots and retainers that they are not worn or damaged.

Replace the parts as needed.

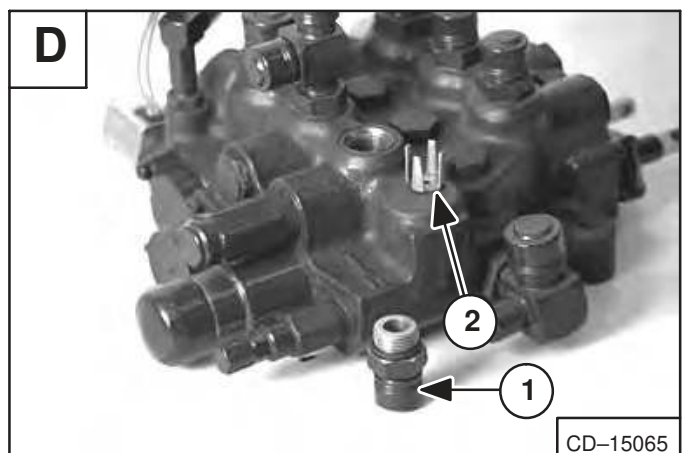
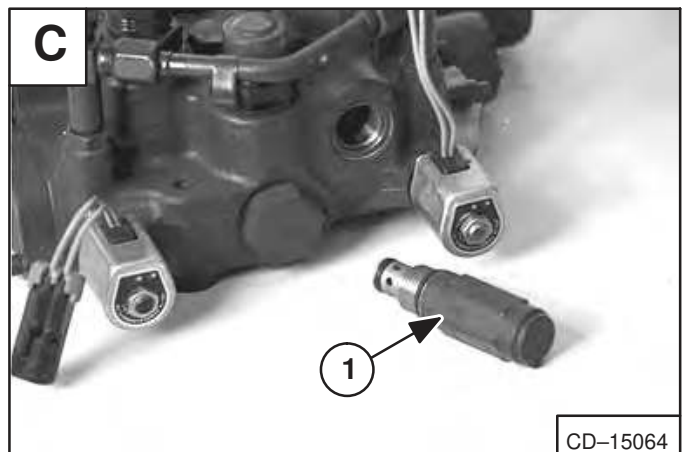

## HYDRAULIC FLUID RESERVOIR

### Draining The Fluid Reservoir

Remove the side cover from the loader frame.

Pull the reservoir drain hose (Item 1) [A] out of the side of the loader frame.

Remove the hose end cap and drain fluid into a container [A].

## IMPORTANT

When making repairs on hydrostatic and hydraulic systems, clean the work area before disassembly and keep all parts clean. Always use caps and plugs on hoses, tubelines and ports to keep dirt out. Dirt can quickly damage the system.

I-2003-0284

## ! WARNING

Always clean up spilled fuel or oil. Keep heat, flames, sparks or lighted tobacco away from fuel and oil. Failure to use care around combustibles can cause explosion or fire which can result in injury or death.

W-2103-1285

### Removal And Installation

Raise the lift arms and install an approved lift arm support device. (See Page 1-1.)

Raise the operator cab. (See Page 1-1.)

Drain the fluid from the reservoir [A].

Remove the front panel/steering lever assembly. (See Page 3-1.)

Remove the lift lock linkage (Item 1) [B].

Disconnect the lift linkage (Item 2) [B] from the crossmember and pedal. Remove the lift linkage.

Remove the side panel (Item 3) [B].

Disconnect the hydrostatic high pressure hose (Item 1) [C].

Remove the hose fitting (Item 2) [C].

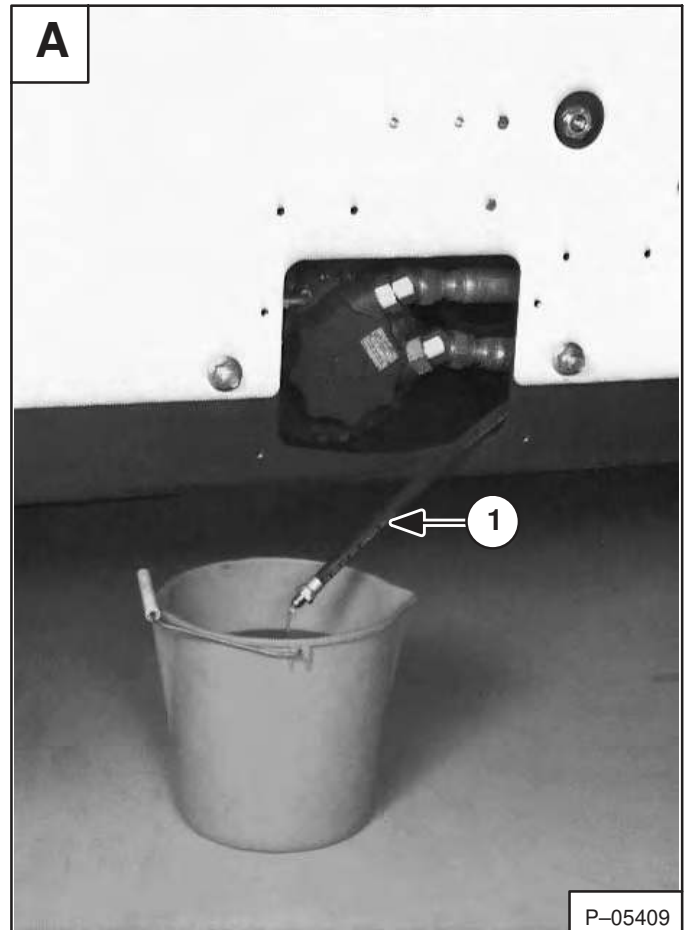

P-05409

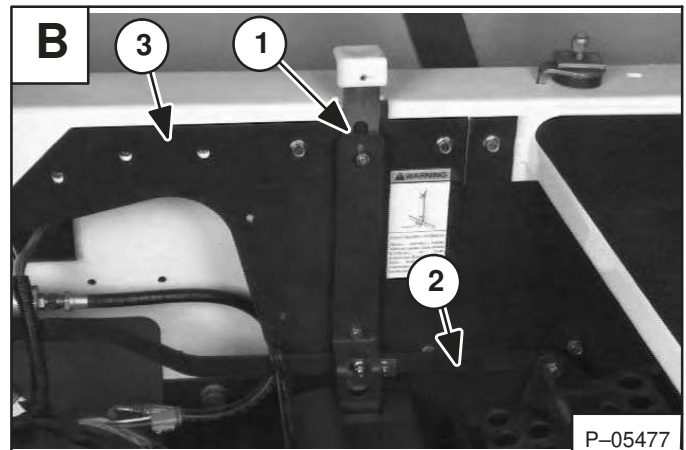

P-05477

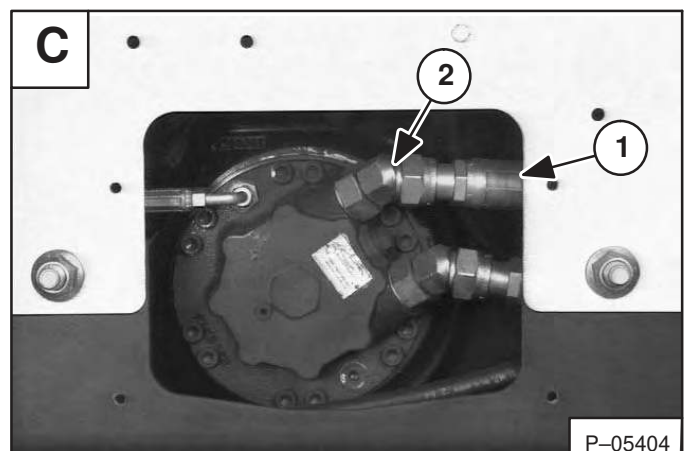

P-05404

## REAR AUXILIARY DIVERTER

### Disassembly

Clean the diverter block to remove dirt before disassembly. Block ports are labeled for correct assembly.

# IMPORTANT

When repairing hydrostatic and hydraulic systems, clean the work area before disassembly and keep all parts clean. Always use caps and plugs on hoses, tubelines and ports to keep dirt out. Dirt can quickly damage the system.

I-2003-0888

Remove the logic cartridge valves from block ports LC1 and LC2 (Item 1) [A].

Remove the pilot check valves from block ports PC1 and PC2 (Item 1) [B].

Remove the shuttle check valve from block port SH1 (Item 2) [B].

Remove the nuts (Item 1) [C], seal washers (Item 2) [C], and solenoid valve coils (Item 3) [C].

Remove the diverter control solenoid valve (Item 4) [C] from port SV1. Remove the pressure relieving solenoid valve (Item 5) [C] from block port SV2.

### Inspection

Inspect cartridges, check valves, solenoid valves and sealing washers for contamination or damage. Wash all parts in clean solvent. Use air pressure for drying them. Install new O-rings and back-up washers.

Inspect diverter block cavities for contamination. Wash block in clean solvent. Use air pressure to dry.

### Solenoid Testing

Use a test meter to measure coil resistance [D]. Coil wires do not have polarity. Correct resistance is 6–9 ohms.

Replace the test meter with 12 volt power. You can see and hear the spool shift.

### Assembly

Put oil on O-rings and back-up washers.

Tighten the Logic cartridge valves (Item 1) [A] to 65 ft.-lbs. (88 Nm) torque.

Tighten the pilot check valves (Item 1) [B], and shuttle check valve (Item 2) [B] to 35 ft.-lbs. (47 Nm) torque.

Tighten the solenoid valves (Items 4 & 5) [C] to 12 ft.-lbs. (16,3 Nm) torque. Install the sealing washers (Item 2) [C] and coils (Item 3) [C]. Tighten the nuts (Item 1) [C] to 10 in.-lbs. (1,13 Nm) torque.

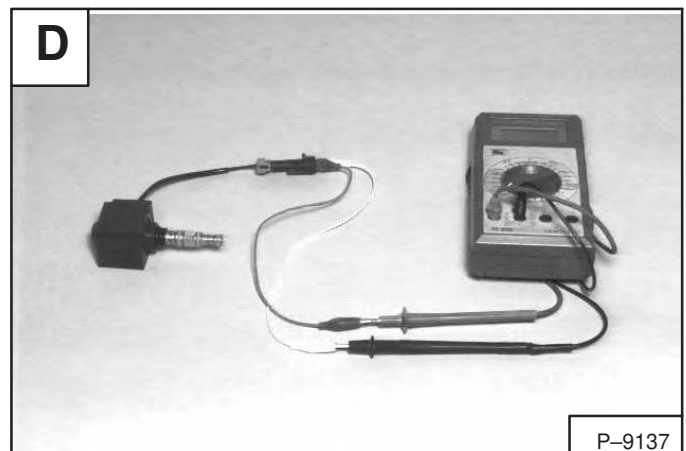
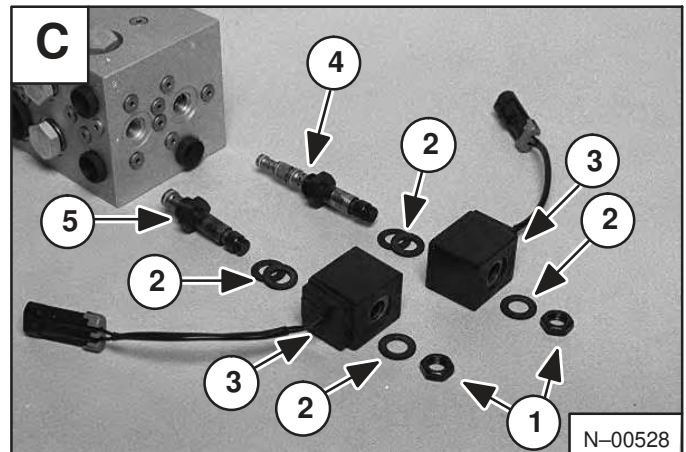
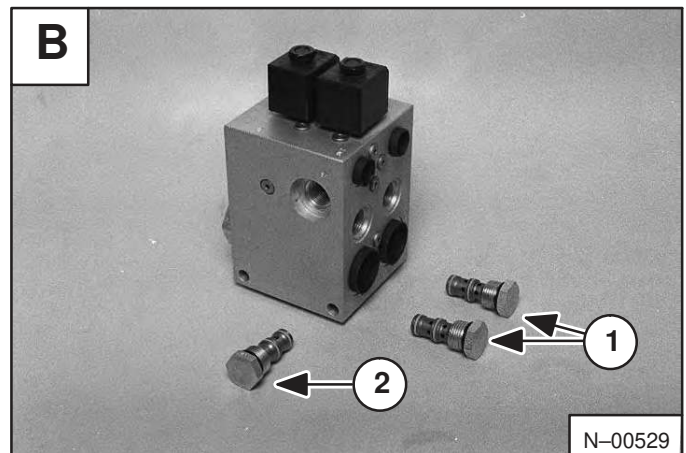
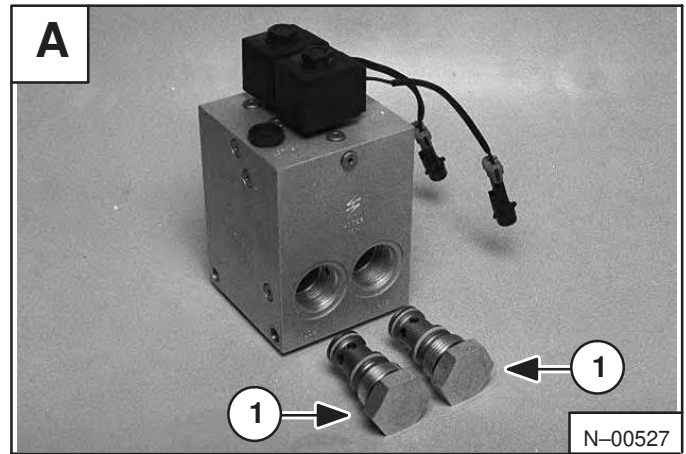

## STEERING LEVERS (Cont'd)

### Pre-Adjustment Checks

Read this adjustment completely to become familiar with the procedure before beginning the adjustment.

The loader should not creep (slow wheel movement) when the steering levers are at rest in the neutral position.

The following special tool will be needed to do the following procedure:

MEL1429A – Remote Start Switch

Lift and block the loader. (See Page 1-1.)

Raise the operator cab. (See Page 1-1.)

Connect the remote start switch. (See Page 1-1.)

## **WARNING**

**When working on the left side of the hydrostatic pump, BE CAREFUL to keep your fingers and tools clear of the cooling fan belt.**

W-2184-0395

Check the following items (Steps 1, 2 & 3) before making any adjustments on the steering linkage:

1. Always check tire pressure and tire size before making any adjustments. Inflate tires to maximum pressure shown on the sidewall of the tire. Be sure the tires do not vary more than 1 inch (25,4 mm) in circumference [A] which could cause different rate of travel and the loader drifting to one side with both steering levers at equal travel.
2. To be sure the hydrostatic pump is in neutral, block the neutral spring bracket out with a deep socket (approximately 7/16 inch) so you can no longer feel the linkage neutral setting [B] & [C].
3. Start the engine. Move the levers while observing the neutral position on the pump servo spool valve. You can feel and see the spring (Item 1) [D] of the pump neutral adjustment. If the wheels do not move when the pump is in the neutral position, then the pump is correctly adjusted. Only linkage adjustment will be necessary for neutral position. If the wheels move when the pump levers are in neutral position, See Page 3-59 for the pump neutral adjustment.
4. Stop the engine. Remove the socket [B].

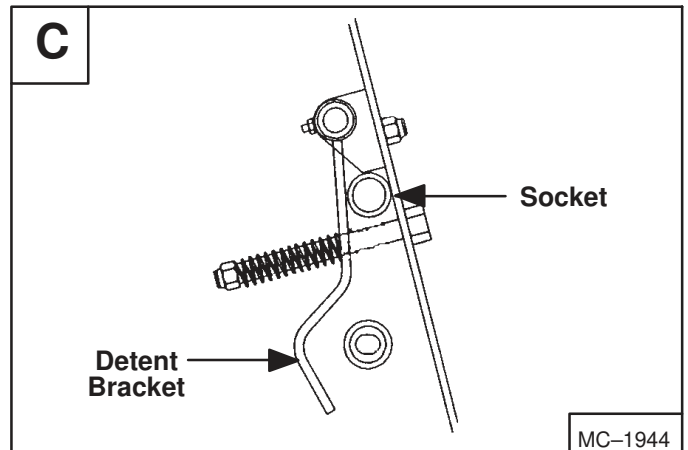
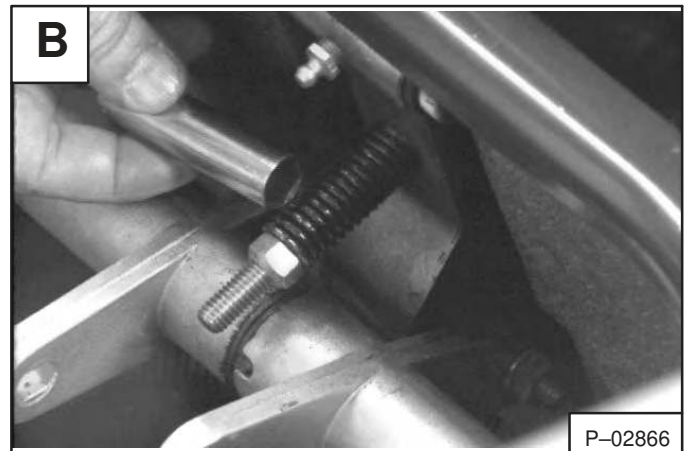

## HYDROSTATIC MOTOR (Cont'd)

### Disassembly (Cont'd)

Remove the plug (Item 1) [A] and spring (Item 2) [A] from the other end of the distributor.

Remove the seven springs (Item 3) [A]

Remove the O-ring from the plug.

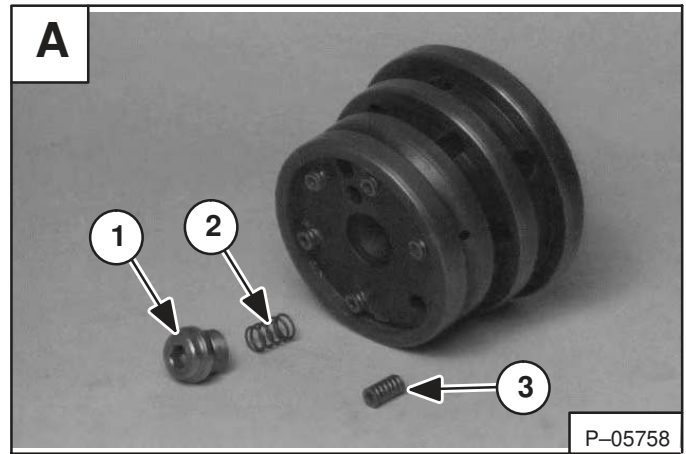

Apply low air pressure to each port in the cylinder block to remove the roller (Item 1) [B] and piston/ring assembly (Item 2) [B].

**NOTE: Put all the roller/piston assembly back in their original position.**

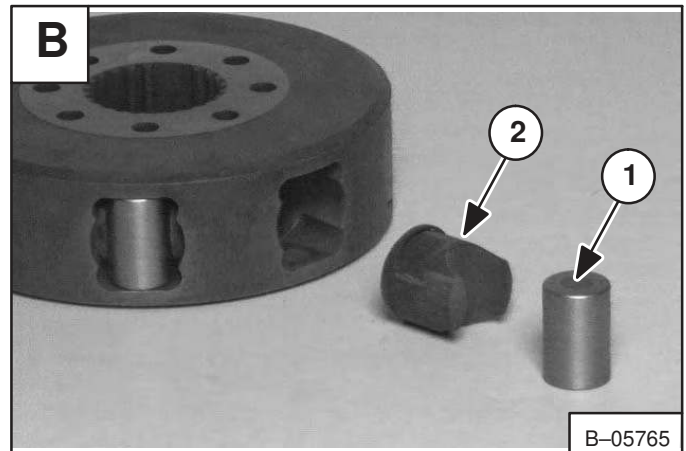

### Inspection

Clean all parts in clean solvent and use air pressure to dry them. DO NOT use cloth or paper because small pieces of material can get into the system and cause damage.

Before the motor is assembled, check the following items:

Check the distributor surface for scratches [C].

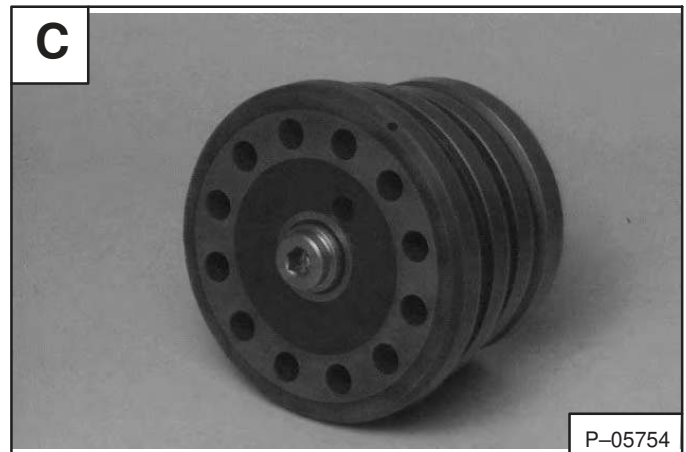

Check the cam ring inside surface for wear and scratches [D].

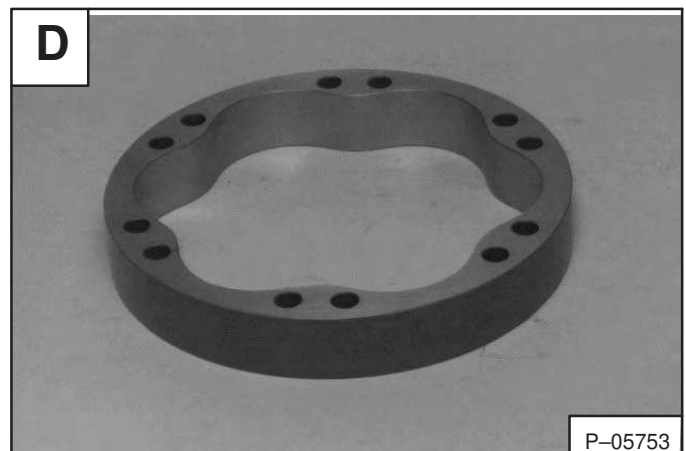

## HYDROSTATIC PUMP

### Removal And Installation

Remove the hydrostatic pump/engine assembly from the loader. (See Page 7-1.)

Remove the belt shield clips (Item 1) [A] and belt shield (Item 2) [A].

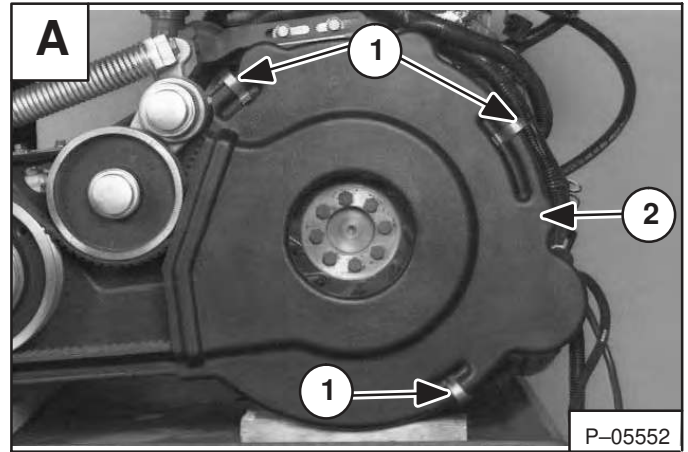

Loosen the stop mounting bolts (Item 1) [B].

Loosen the spring tension bolt (Item 2) [B].

Remove the drive belt (Item 3) [B].

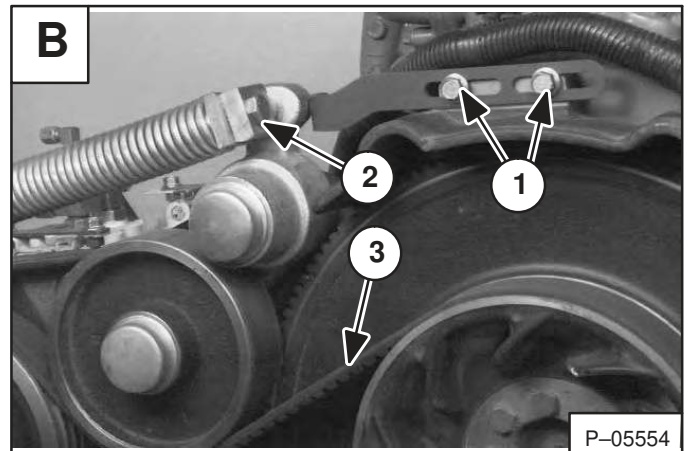

Remove the washer and nut (Item 1) [C] from the hydrostatic pump drive shaft.

**Installation:** Tighten the nut to 175–200 ft.-lbs. (237–271 Nm) torque.

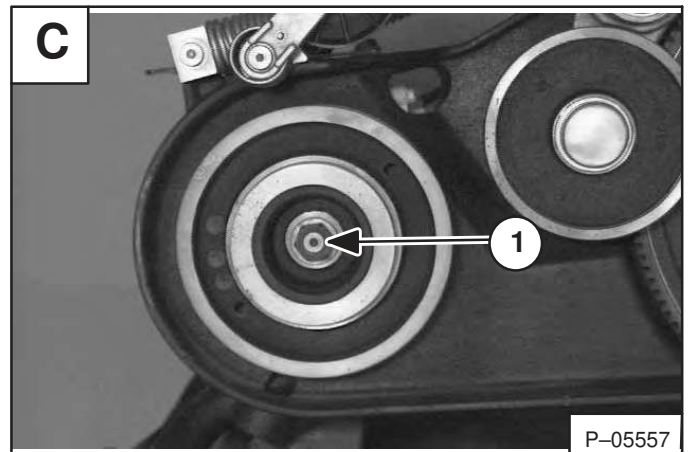

Install the nut on the end of the pump drive shaft (without washer).

Use a puller (Item 1) [D] to remove the pulley from the pump drive shaft.

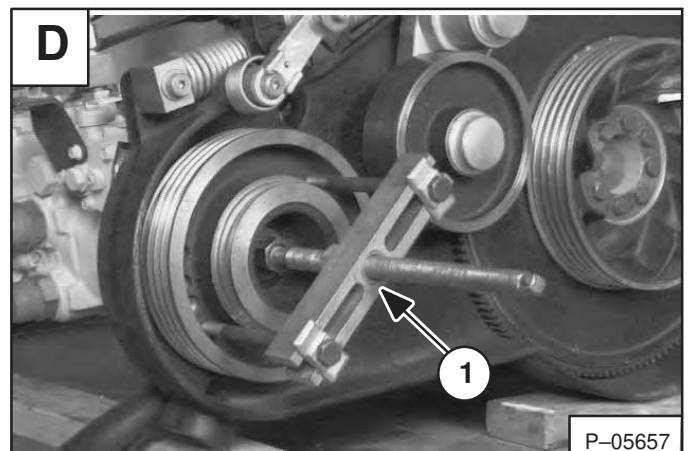

## HYDROSTATIC PUMP (Cont'd)

### Disassembly (Cont'd)

◇ Remove the three bolts at the adapter housing [A].

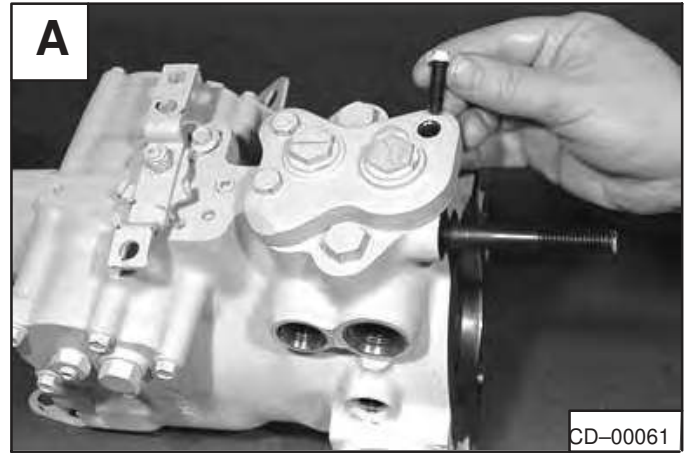

◆ Remove the adapter housing and plate (Item 1) [B].

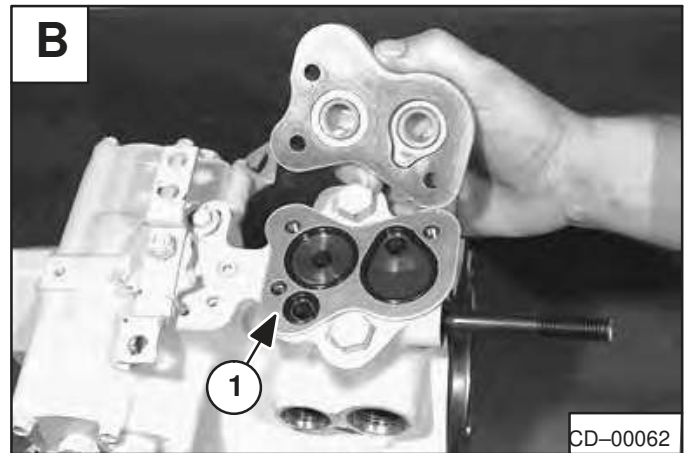

Remove the plug at the control inlet orifice port [C].

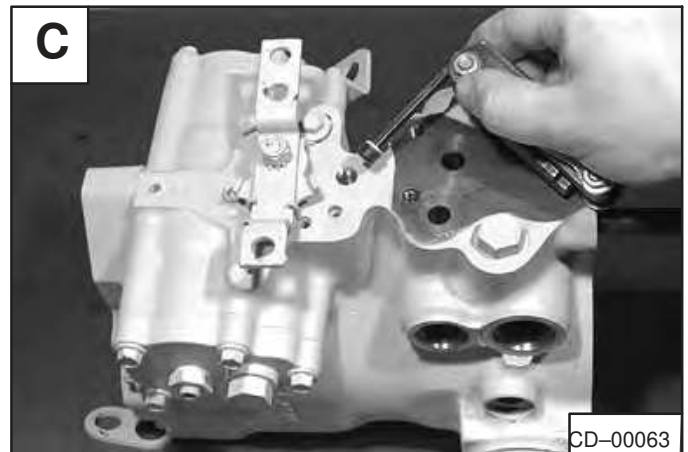

Remove the screened orifice plug (Item 1) [D].

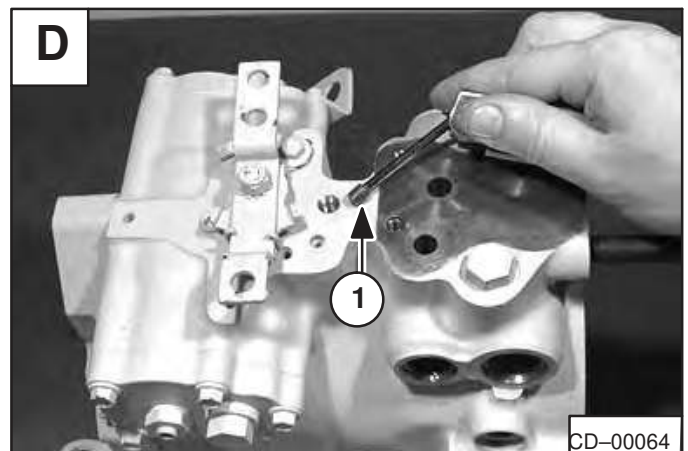

◇ Right Pump  
◆ Left Pump

## HYDROSTATIC PUMP (Cont'd)

### Inspection (Cont'd)

Check the spherical washer for wear or damage [A].



Check the three pins [B].

The pins must not be bent. All pins must be the same length.

**NOTE: If there is any defect in the rotating group, the complete rotating group must be replaced.**



### Assembly

If disassembly, assembly as shown in Fig. [C]:

1. Long Spring Guide
2. Stop
3. Spring
4. Short Spring Guide
5. Nut
6. Lock Nut
7. Centering Bolt.

Put oil on the long spring guide before assembly.

Hold the centering screw from turning and tighten the nut to compress the spring.

Install the centering spring assembly and snap ring into the piston [D].

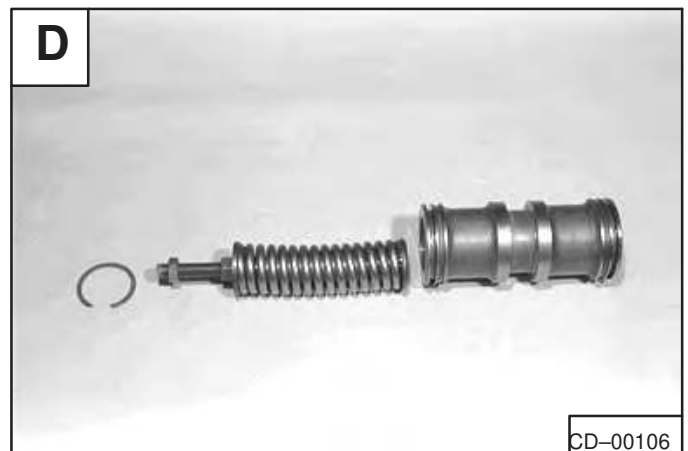
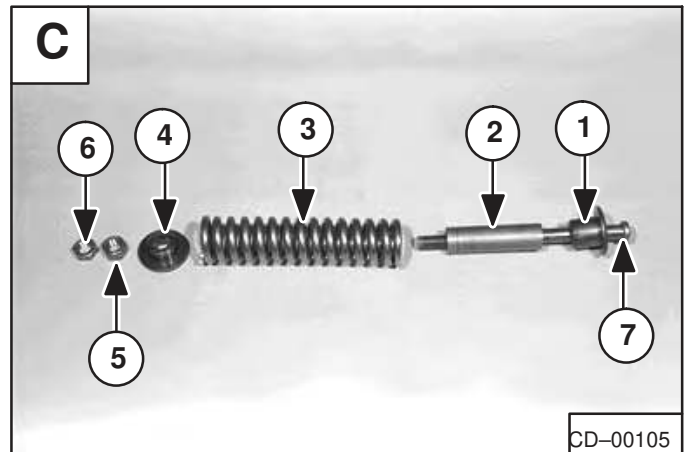

## HYDROSTATIC PUMP (Cont'd)

### Charge Pump Assembly (Cont'd)

Apply petroleum jelly to two new O-rings. Install the O-rings on the gerotor cover **[A]**.

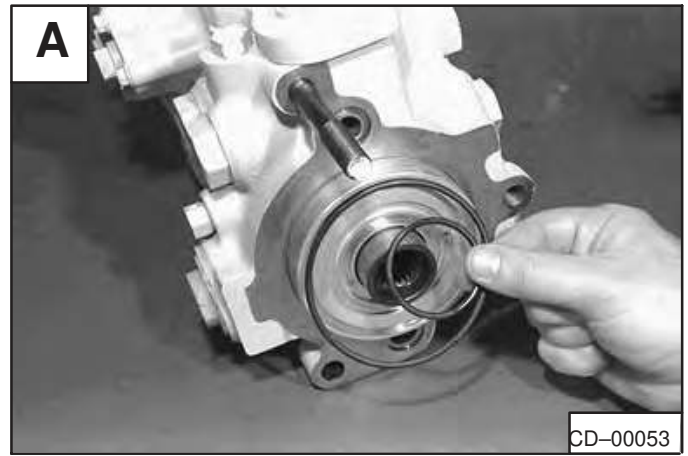

### Hydrostatic Pump Connection

Apply petroleum jelly to two new small O-rings (Item 1) **[B]** and a large O-ring (Item 2) **[B]**. Install the O-rings on the rear pump.

Connect the two hydrostatic pumps **[B]**.

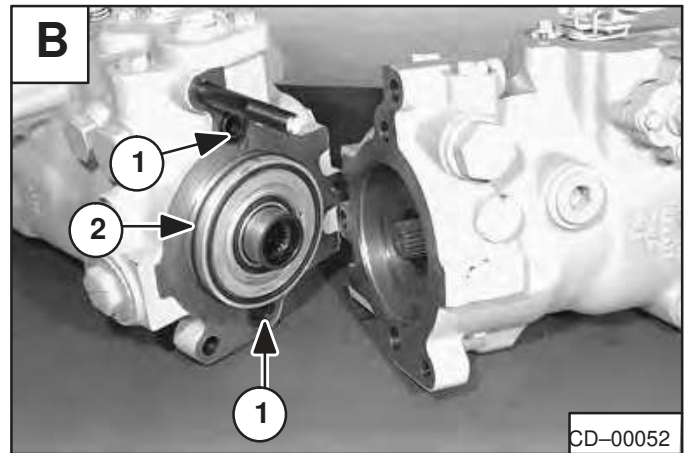

Install the lift bracket and nut **[C]**.

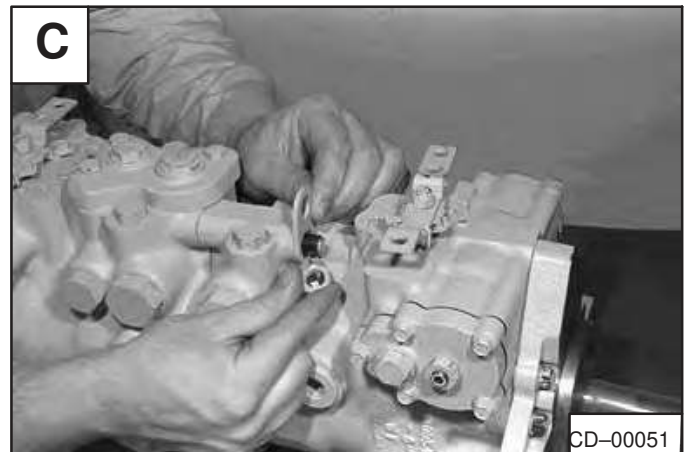

Install a bolt on both sides of the pump assembly **[D]**.

Evenly tighten the two bolts and nuts to 67–82 ft.-lbs. (91–111 Nm) torque.

Rotate the tandem pump input shaft to check for proper assembly.

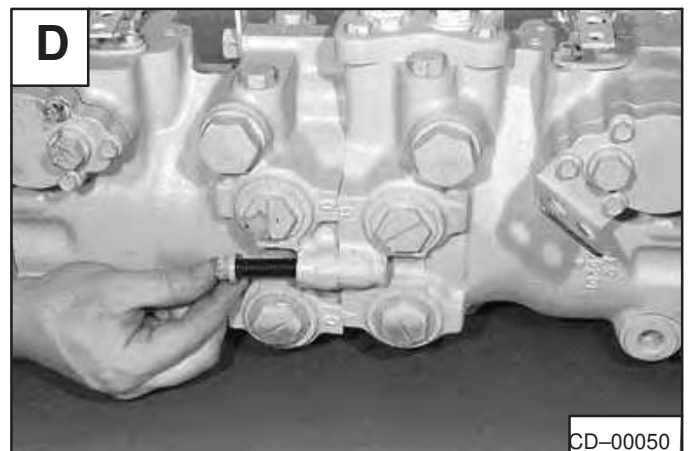

## OIL COOLER (Cont'd)

### Removal And Installation (S/N 514111515 & Below)

Raise the lift arms and install an approved lift arm support device. (See Page 1-1.)

Raise the operator cab. (See Page 1-1.)

Remove the rear grill. (See Page 5-1.)

Remove the blower fan and housing. (See Page 7-1.)

Disconnect the hoses (Item 1) [A] from the engine and drain the engine oil from the oil cooler into a container.

**NOTE: Measure the amount of oil removed from the oil cooler and/or engine. Add the same amount of oil to the engine crankcase when adding engine oil.**

Remove the tubeline (Item 1) [B].

Disconnect and remove the tubeline (Item 1) [C].

Disconnect the hose (Item 1) [D].

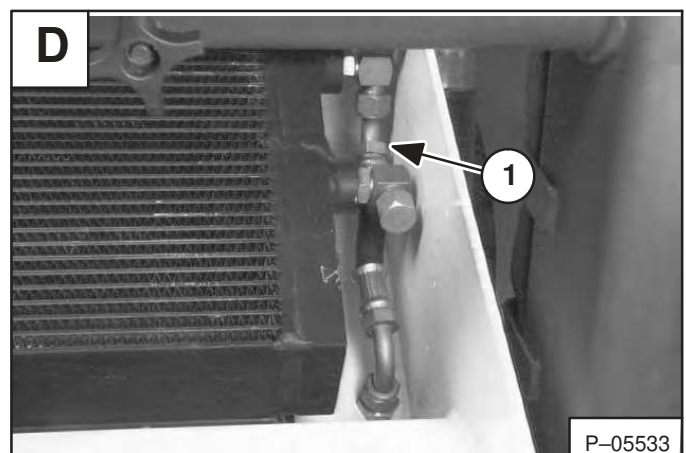
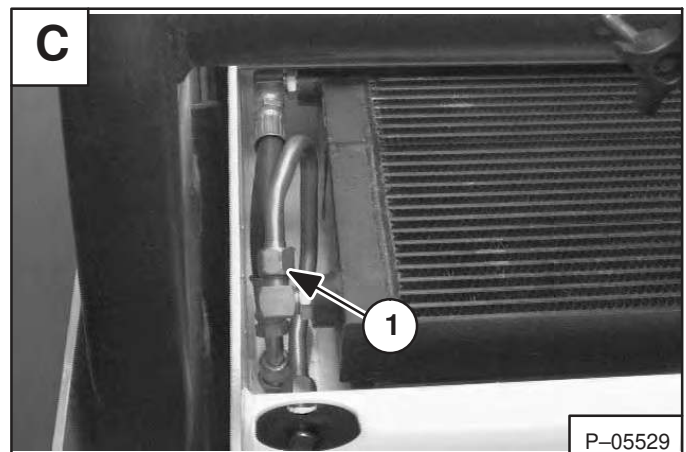
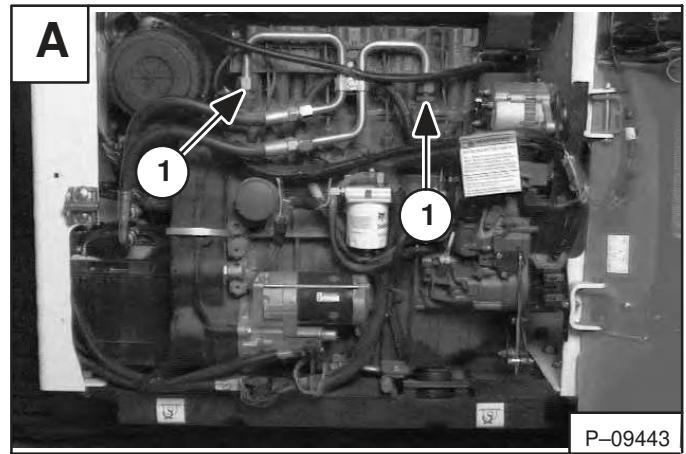

## BRAKE DISC (Cont'd)

### Removal And Installation (Old Style Disc) (Cont'd)

The brake disc guide can be replaced by removing the guide mounting bolts (Item 1) [A].

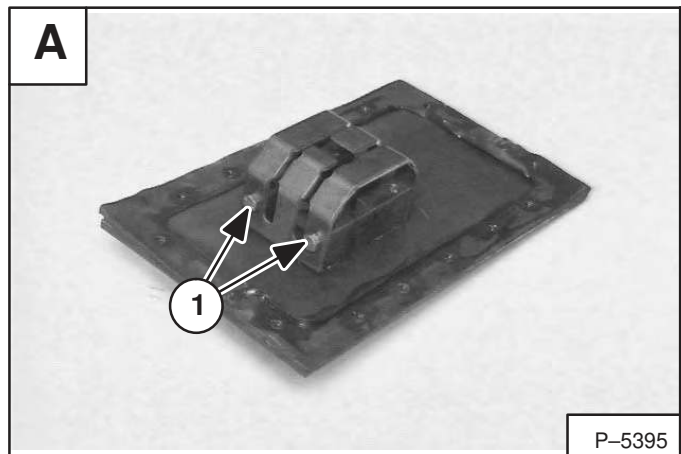

## FRONT CHAINCASE COVER

### Removal And Installation

Remove the front panel. (See Page 3-1.)

Remove the parking brake pedal. (See Page 4-3.)

Remove the mounting bolts from the front chaincase cover (Item 1) [B].

Remove the cover.

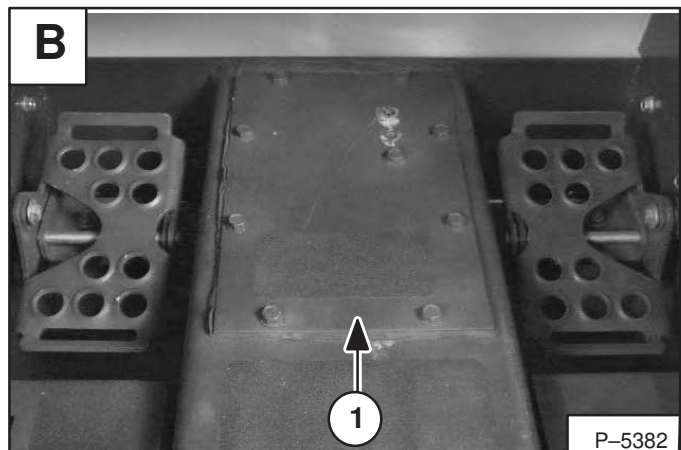

## REAR CHAINCASE COVER

### Removal And Installation

Raise the lift arms and install an approved lift arm support device. (See Page 1-1.)

Raise the operator cab. (See Page 1-1.)

Remove the mounting bolts from the rear chaincase cover (Item 1) [C].

Remove the cover.

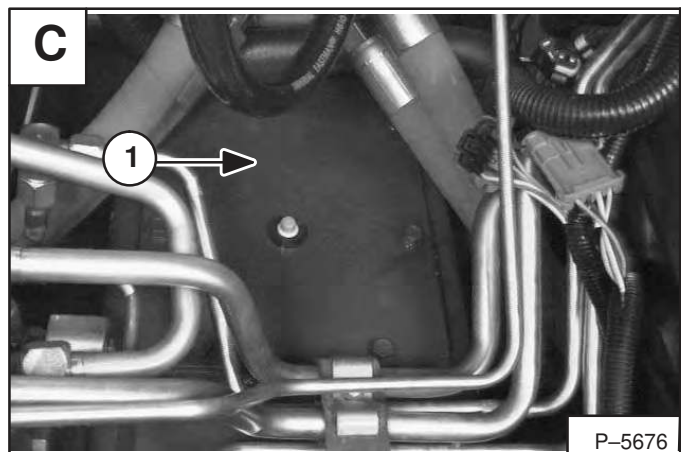

## MAIN FRAME

	<b>Page Number</b>
<b>BOB-TACH</b>	
Bob-Tach Lever And Wedge .....	5-19
Pivot Pin Bushing And Seal Replacement .....	5-20
Removal And Installation .....	5-18
<b>FUEL TANK</b>	
Fuel Level Sender .....	5-32
Inlet Screen .....	5-32
Removal And Installation .....	5-30
<b>LIFT ARMS</b>	
Removal And Installation .....	5-24
<b>LIFT ARM STABILIZER BAR</b>	
Removal And Installation .....	5-21
<b>LIFT ARM LINK</b>	
Removal And Installation .....	5-22
<b>OPERATOR CAB</b>	
Removal And Installation .....	5-14
<b>OPERATOR CAB GAS CYLINDER</b>	
Disassembly And Assembly .....	5-13
Removal And Installation .....	5-12
<b>OPERATOR SEAT</b>	
Removal And Installation .....	5-17
<b>REAR DOOR</b>	
Bumper Removal And Installation .....	5-29
Door Latch And Catch Adjustment .....	5-29
Door Latch Removal And Installation .....	5-29
Hood Removal And Installation .....	5-29
Removal And Installation .....	5-28
<b>REAR GRILL</b>	
Removal And Installation .....	5-27
<b>SEAT BAR (W/COMPRESSION SPRING)</b>	
Assembling Components .....	5-11
Compression Spring Disassembly And Assembly .....	5-11
Removal And Installation .....	5-8
<b>SEAT BAR (W/GAS SPRING)</b>	
Assembly .....	5-5
Compressing The Gas Cylinder .....	5-6
Removal And Installation .....	5-3

**MAIN  
FRAME**

## SEAT BAR (W/COMPRESSION SPRING) (Cont'd)

### Assembling Components

Assemble the parts as shown for the left side of the seat bar pivot assembly **[A]**:

- Mounting Bolt (Item 1)
- Washer (Item 2)
- Keyed Plastic Bushing (Item 3)
- Magnetic Bushing Assembly (Item 4)
- Sensor Mounting Nut (Item 5)
- Sensor Bracket (Item 6)
- Sensor Mounting Bolt (Item 7)
- Pivot Bushing (Item 8)
- Mounting Bolt (Item 9)

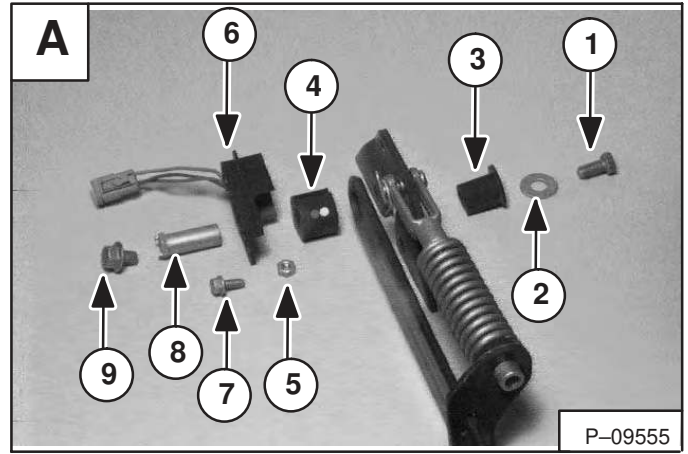

Assemble the parts as shown for the right side of the seat bar pivot assembly **[B]**:

- Mounting Bolt (Item 1)
- Pivot Bushing (Item 2)
- Mounting Bracket (Item 3)
- Keyed Plastic Bushing (Item 4)
- Washer (Item 5)
- Mounting Bolt (Item 6)

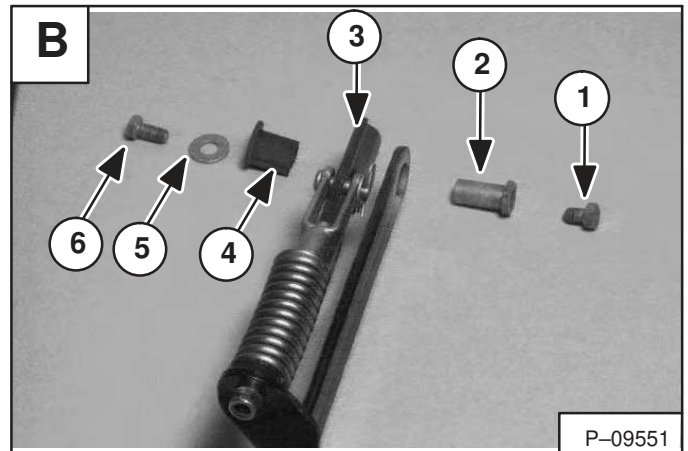

### Compression Spring Disassembly And Assembly

Loosen the lock nut (Item 1) **[C]** and turn the bolt (Item 2) **[C]** out of the clevis.

**Assembly:** Adjust the compression spring as shown on Page 5-8; Fig. **[C]**.

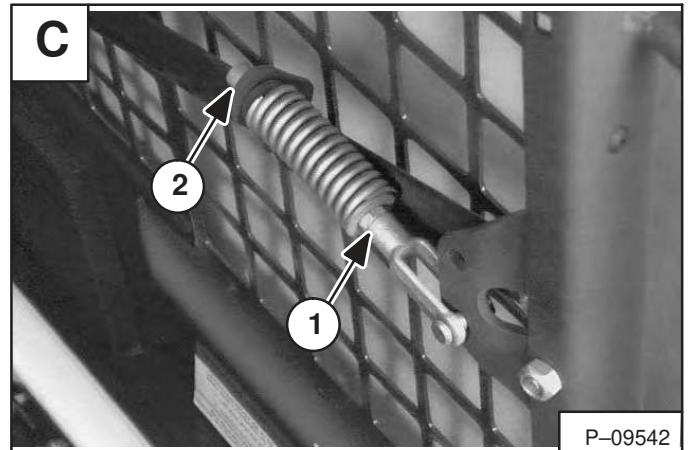

Disassemble and assemble the seat bar compression spring and parts as shown in Fig. **[D]**:

- Pin (Item 1)
- Retaining Pin (Item 2)
- Clevis (Item 3)
- Lock Nut (Item 4)
- Washer (Item 5)
- Spring (Item 6)
- Bushing (Item 7)
- Bolt (Item 8)

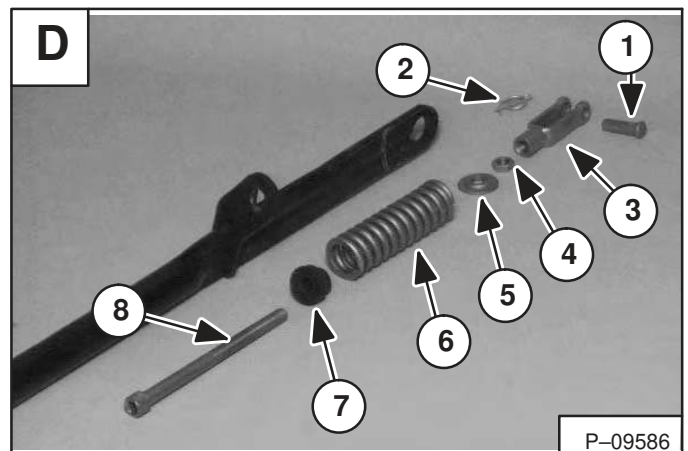

## LIFT ARM STABILIZER BAR

### Removal And Installation

Lift and block the loader. (See Page 1-1.)

Remove the wheel/tire assembly from the side of the loader where the stabilizer bar is removed from.

Install a chain (Item 1) [A] around the axle tube and connect it to the lift arms.

Put a floor jack under the Bob-Tach frame [A].

Remove the retainer bolt (Item 2) [A] and nut from the stabilizer bar pivot pin.

**Installation:** Tighten the retainer bolt and nut to 18–20 ft.-lbs. (24–27 Nm) torque.

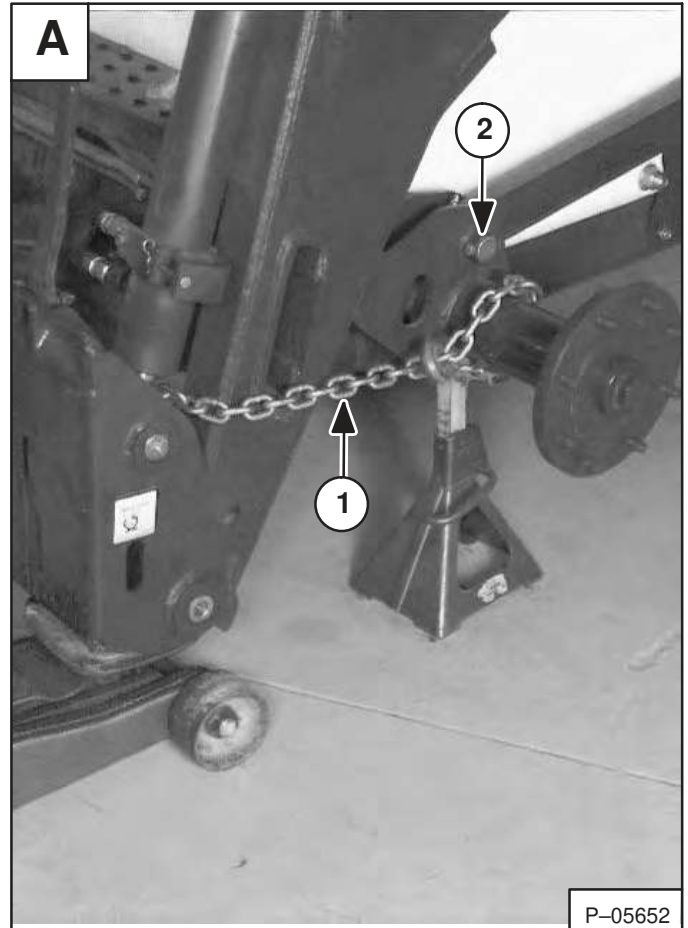

Remove the stabilizer bar pivot pin (Item 1) [B].

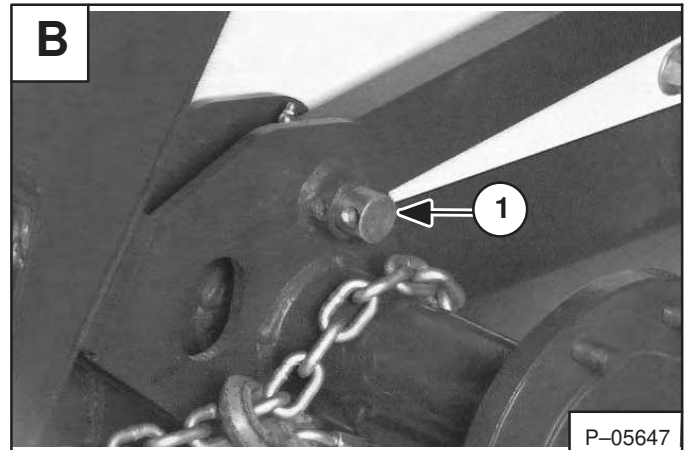

Remove the retainer bolt (Item 1) [C] from the rear stabilizer bar pivot pin.

**Installation:** Tighten the retainer bolt to 18–20 ft.-lbs. (24–27 Nm) torque.

Remove the stabilizer bar pivot pin (Item 2) [C].

Remove the stabilizer bar.

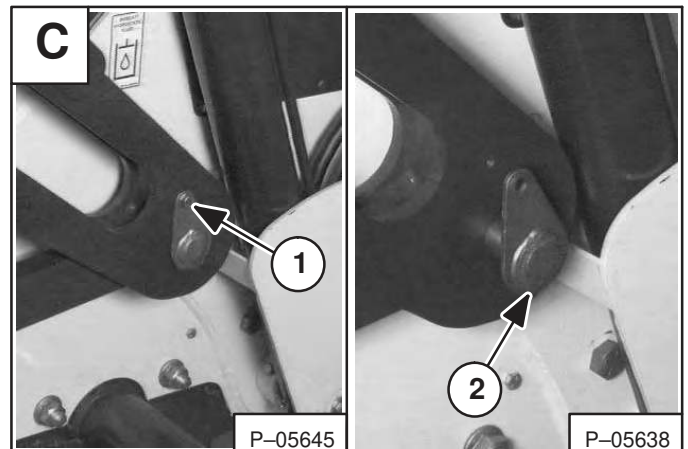

## FUEL TANK (Cont'd)

### Removal And Installation (Cont'd)

Remove the bolts (Item 1) **[A]** from the battery holddown plate.

Remove the holddown plate from the loader.

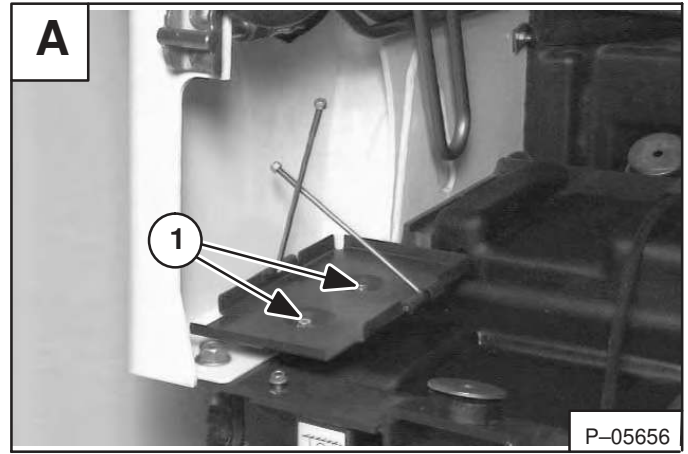

Remove the mounting plate (Item 1) **[B]** for the battery holddown plate.

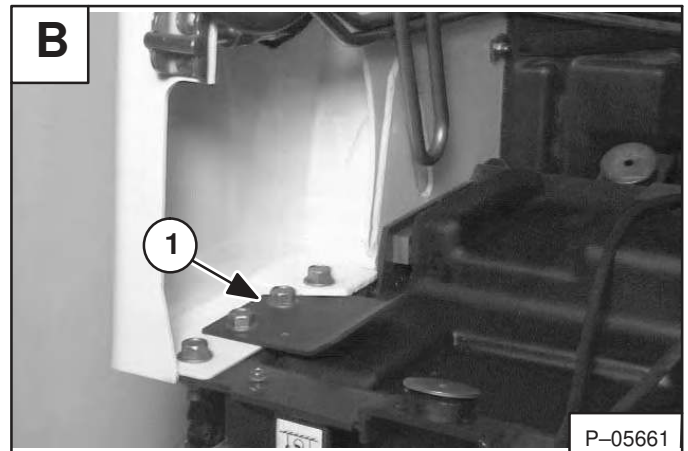

Lift the fuel tank and remove it from the loader frame **[C]**.

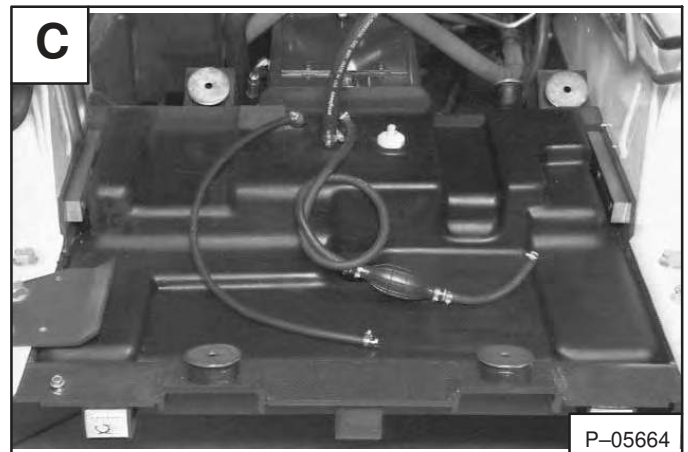



# EUROPEAN CAB WIRING DIAGRAM - SHEET 5

With BOSS

(Harness 6710483 Rev. A)

873 BICS™ (S/N 514211274-12999)

(Printed August 1997)

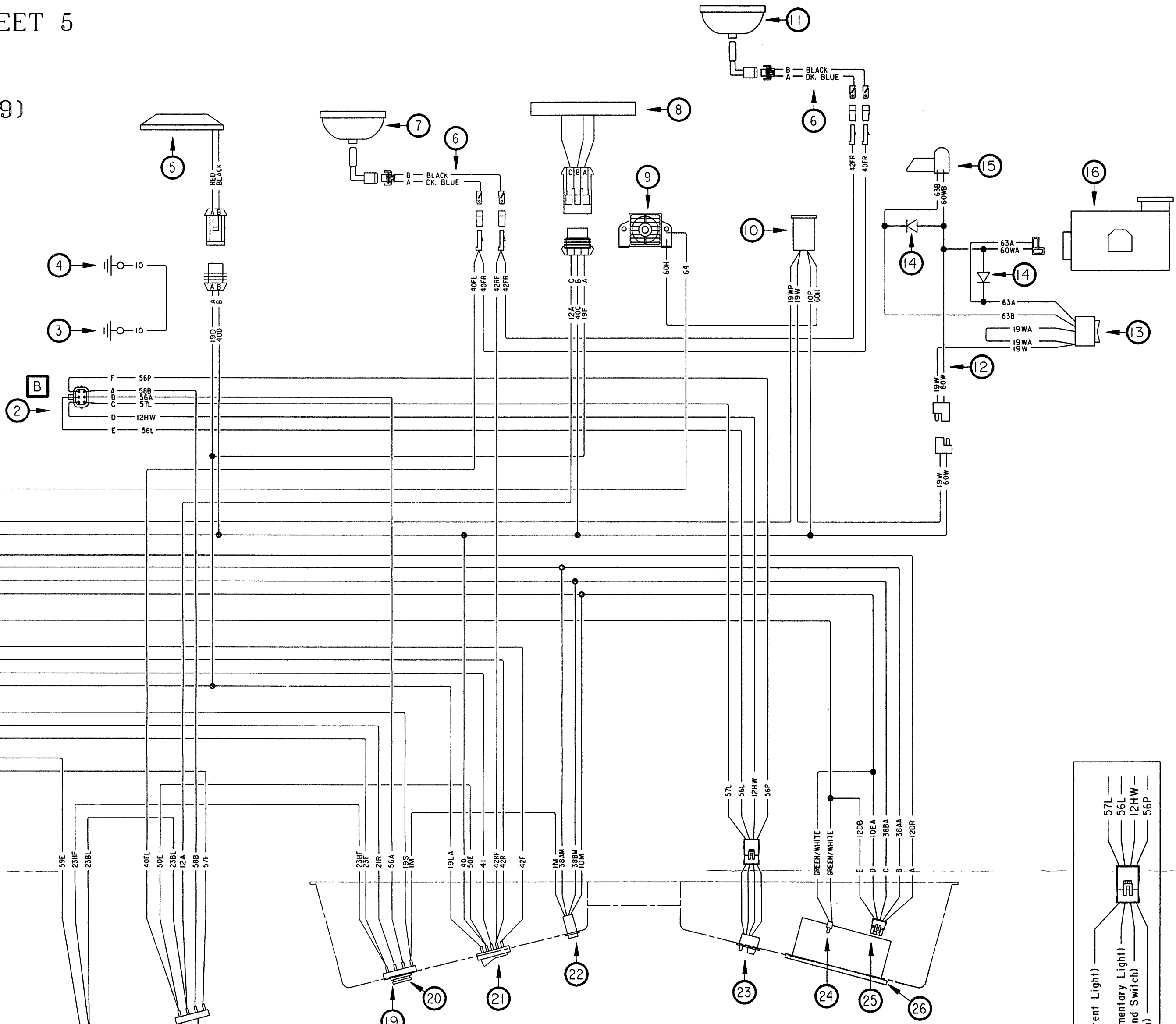
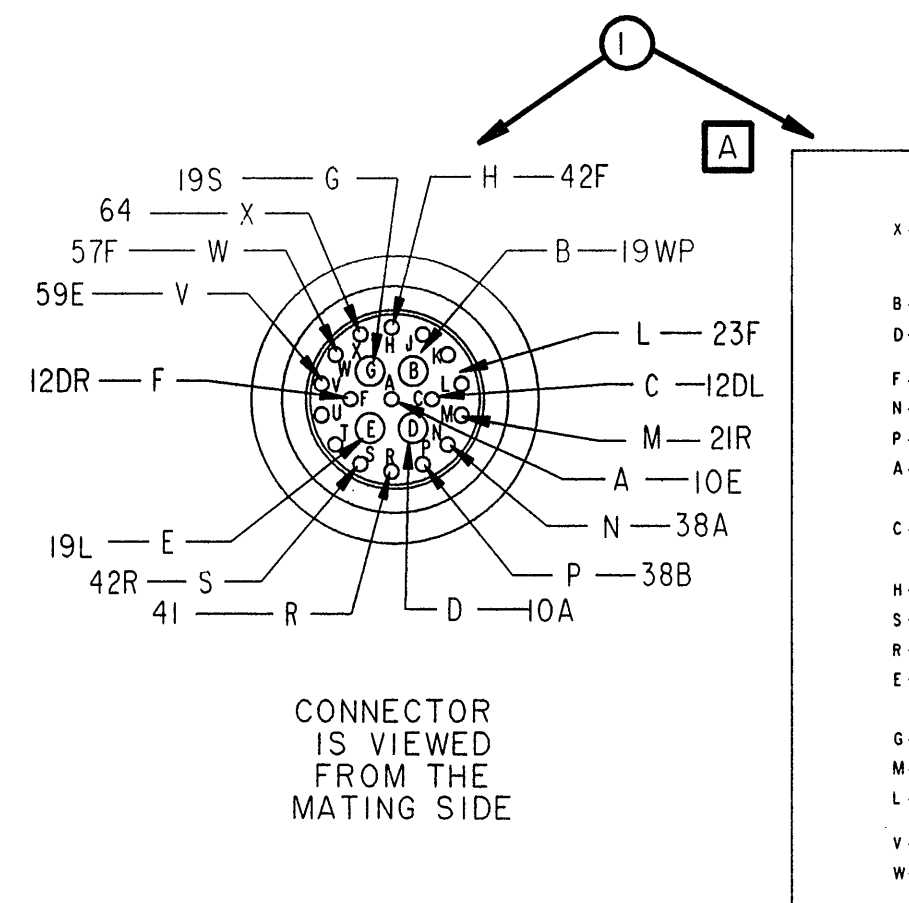

—||— Denotes Ground

**A** Connects To **A** Engine Wiring Diagram - Sheet 6

**B** Connects To **B** Controls Wiring Diagram - Sheet 3

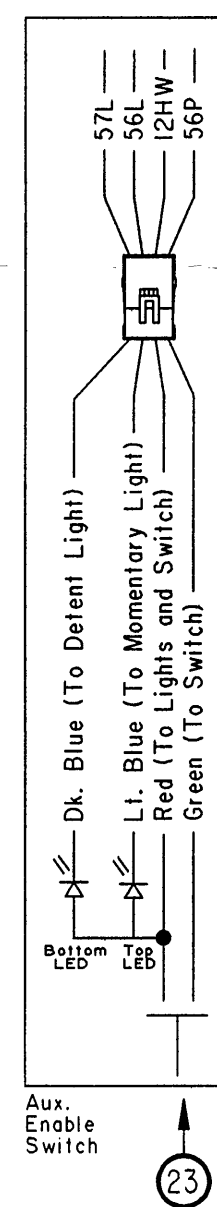
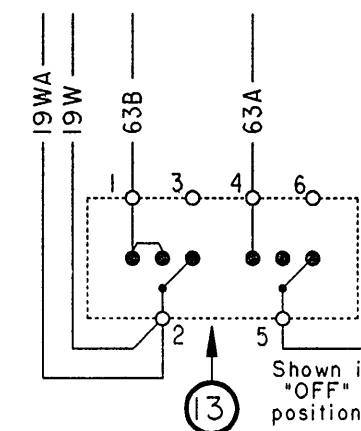
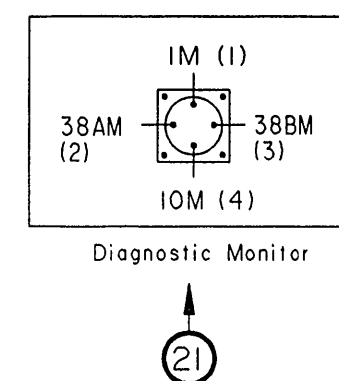
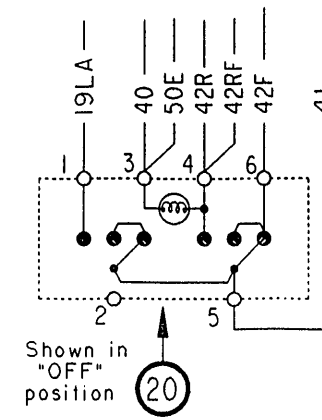
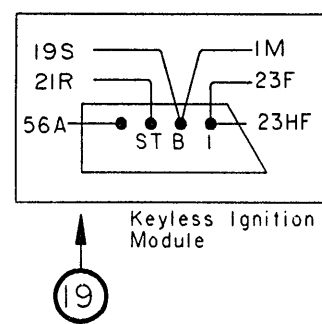
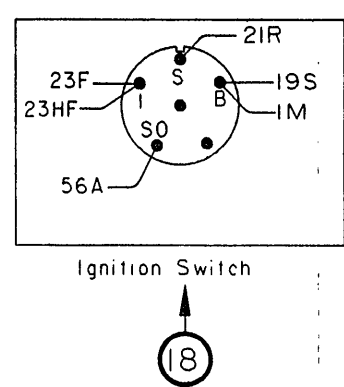
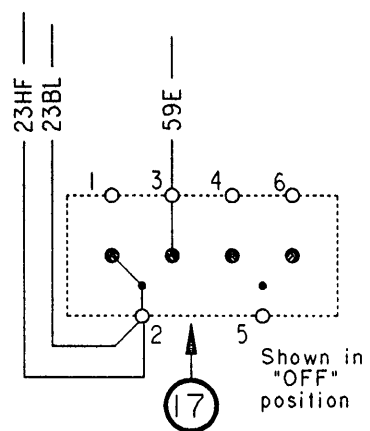

CLICK HERE TO **DOWNLOAD** THE COMPLETE MANUAL

- Thank you very much for reading the preview of the manual.
- You can download the complete manual from: [www.heydownloads.com](http://www.heydownloads.com) by clicking the link below



- Please note: If there is no response to **CLICKING** the link, please download this PDF first and then click on it.

CLICK HERE TO **DOWNLOAD** THE COMPLETE MANUAL



ENGINE WIRING DIAGRAM - SHEET 6

With BOSS  
(Harness 6710493)

873 BICS™ (514112612-14999)

(514211274-12999)

(Printed August 1997)

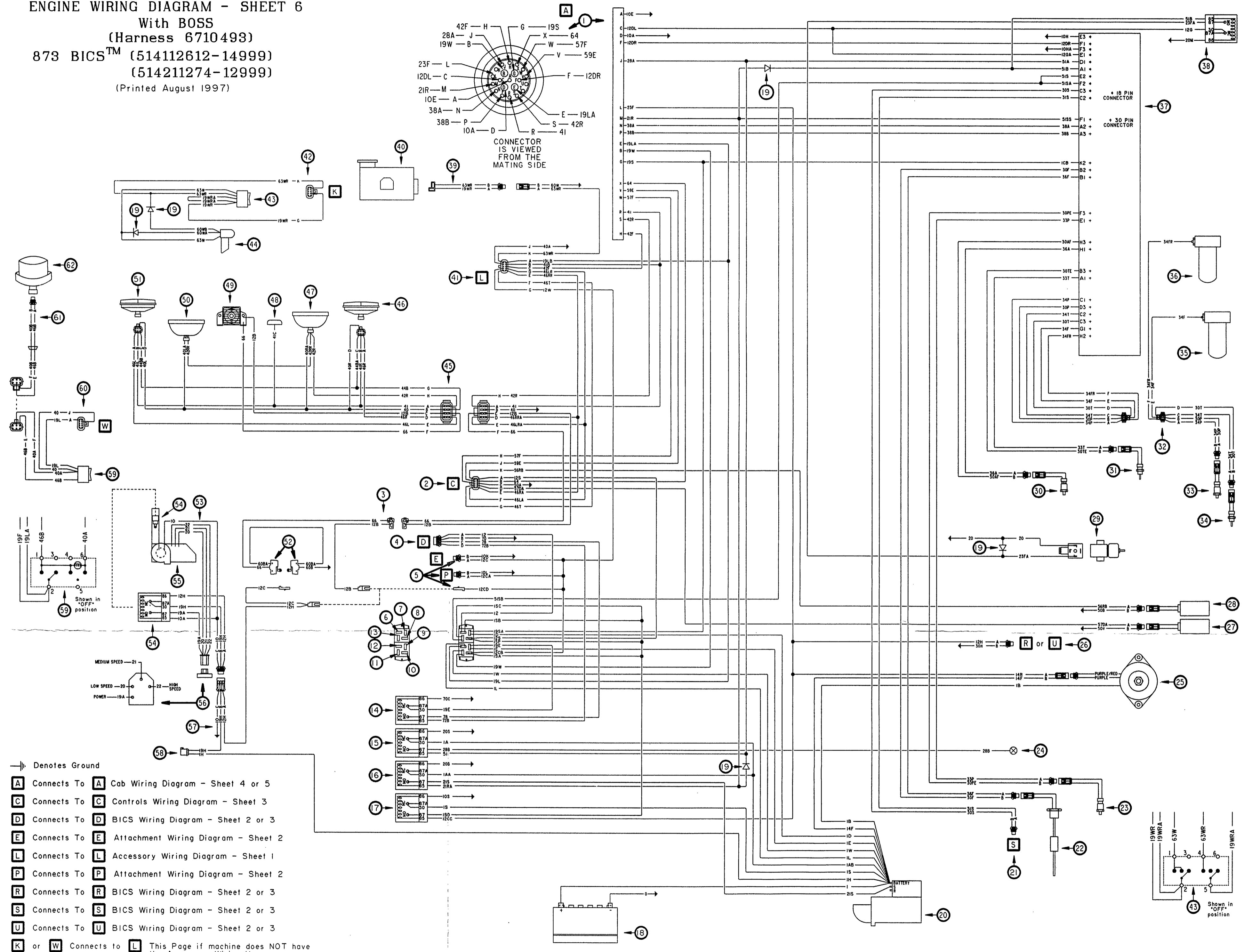
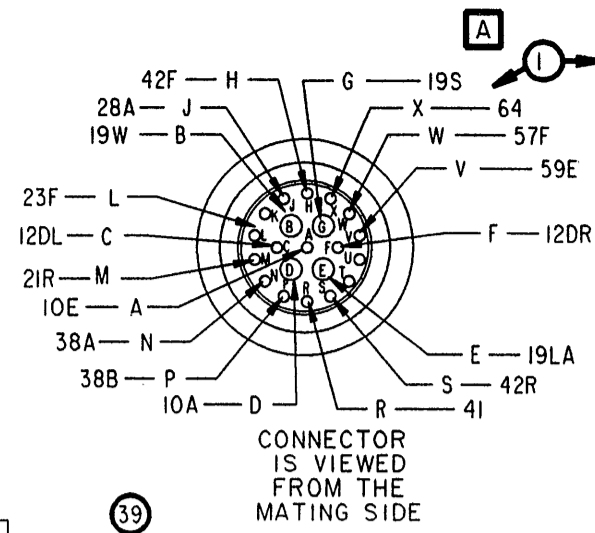

⊥ Denotes Ground

- A** Connects To **A** Cab Wiring Diagram - Sheet 4 or 5
- C** Connects To **C** Controls Wiring Diagram - Sheet 3
- D** Connects To **D** BICS Wiring Diagram - Sheet 2 or 3
- E** Connects To **E** Attachment Wiring Diagram - Sheet 2
- L** Connects To **L** Accessory Wiring Diagram - Sheet 1
- P** Connects To **P** Attachment Wiring Diagram - Sheet 2
- R** Connects To **R** BICS Wiring Diagram - Sheet 2 or 3
- S** Connects To **S** BICS Wiring Diagram - Sheet 2 or 3
- U** Connects To **U** BICS Wiring Diagram - Sheet 2 or 3
- K** or **W** Connects to **L** This Page if machine does NOT have the Accessory Wiring Harness



## WIRE LEGEND

NO. 's	COLOR	GAUGE
12	Orange	16
12A	Orange	16
12B	Orange	16
12H	Orange	16
12HA	Orange	16
12HB	Orange	16
30	Black	16
30H	Black	16
30HA	Black	16
30HB	Black	16
30S	Green	16
30SA	Green/Lt. Blue	16
31S	Yellow/Lt. Blue	16
31SA	Yellow	16
54BF	Purple/White	16
54BT	Purple/Red	16
70	Black (BICS Controller Harness)	16
70	Black (Mainframe Harness)	14
70A	Black (BICS Controller Harness)	16
70A	Black (Mainframe Harness)	14
70B	Black	16
70D	Black	16
71A	Dk. Green	16
72A	Red	16
72B	Pink/White	16
73A	Blue	16
73B	White	16
73BA	White/Lt. Blue	16
73BB	White	16
74A	Lt. Blue/Red	16
74B	Lt. Blue/Black	16
74C	Lt. Blue/Green	16
75A	Dk. Blue/White	16
75B	Gray	16
76A	Yellow/Red	16
76B	Yellow/Black	16
76C	Yellow/Green	16
77A	Yellow	16
77B	Yellow/Blue	16
78	White	14

## PARTS LEGEND

- ① BICS European Controller Harness  
6712135 Rev. B
- ② BICS Controller
- ③ Traction Lock (Brake) Override  
Switch
- ④ Seatbar Sensor
- ⑤ Seat Sensor
- ⑥ Traction Lock (Manual Brake)  
Assembly Switch
- ⑦ Traction Lock (Brake)  
Solenoid
- ⑧ Hydraulic Tilt Lock Valve  
Solenoid
- ⑨ Mainframe Controller Harness  
6712523
- ⑩ Controls Connector
- ⑪ Travel Control Switch
- ⑫ Traction Controller
- ⑬ Traction Control Harness  
6713455
- ⑭ Magnetic Pickup Connector  
(873 BOSS ONLY)
- ⑮ Magnetic Pickup
- ⑯ Auxiliary Power Connector
- ⑰ Auxiliary Power Harness (Opt.)  
6713596

ATTACHMENT WIRING DIAGRAM - SHEET 2  
 (Harness 6710299 and 6710300 Rev. A)  
 873 BICS™ (S/N 514111502-14999)  
 (S/N 514211108-12999)  
 (Printed August 1997)

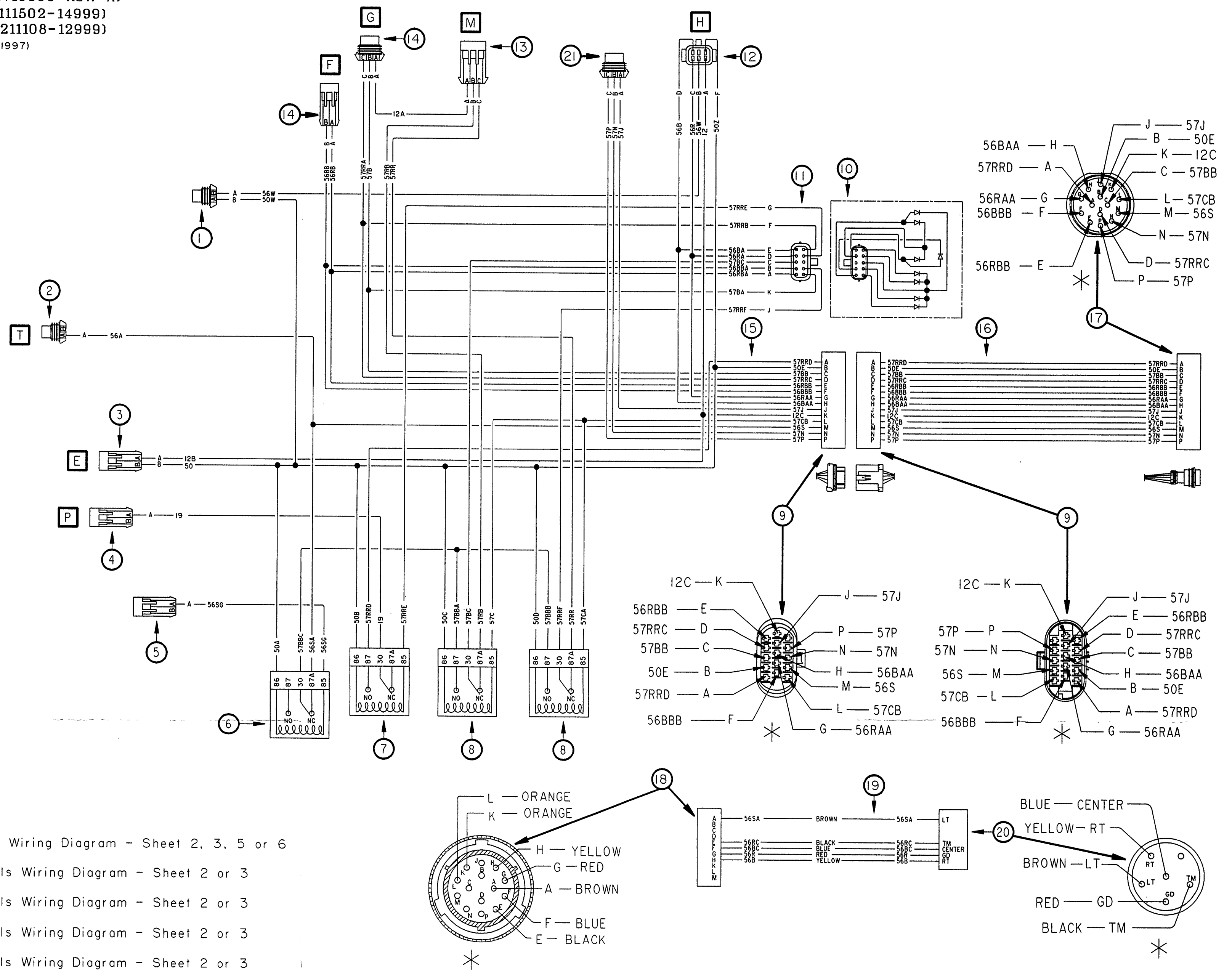

- E** Connects To **E** Engine Wiring Diagram - Sheet 2, 3, 5 or 6
- F** Connects To **F** Controls Wiring Diagram - Sheet 2 or 3
- G** Connects To **G** Controls Wiring Diagram - Sheet 2 or 3
- H** Connects To **H** Controls Wiring Diagram - Sheet 2 or 3
- M** Connects To **M** Controls Wiring Diagram - Sheet 2 or 3
- P** Connects To **P** Engine Wiring Diagram - Sheet 2, 3, 5 or 6
- T** Connects To **T** Controls Wiring Diagram - Sheet 2 or 3

\* LOADER CONNECTOR IS VIEWED FROM THE MATING SIDE

## BATTERY (Cont'd)

### Removal and Installation (Cont'd)

Always clean the terminals and cable ends when installing a new battery **[A]** and **[B]**.

When installing the battery in the loader, do not touch any metal parts with the battery terminal posts.

Connect and tighten the battery cables. Connect the negative (-) cable last to prevent sparks.



## WARNING

Batteries contain acid which burns eyes and skin on contact. Wear goggles, protective clothing and rubber gloves to keep acid off body.

In case of acid contact, wash immediately with water. In case of eye contact get prompt medical attention and wash eye with clean, cool water for at least 15 minutes.

If electrolyte is taken internally drink large quantities of water or milk. DO NOT induce vomiting. Get prompt medical attention.

W-2065-1296

### Servicing the Electrical System

The battery cables must be clean and the connections tight. Remove acid or corrosion from the battery and cables with a sodium bicarbonate (baking soda) and water solution **[C]**.

Clean the terminals and cable ends as shown in Fig. **[A]** and **[B]**.

Check the electrolyte level in the battery. Add distilled water as needed.

Put Battery Saver (P/N 6664458) or grease on the battery terminals and cable ends to prevent corrosion.

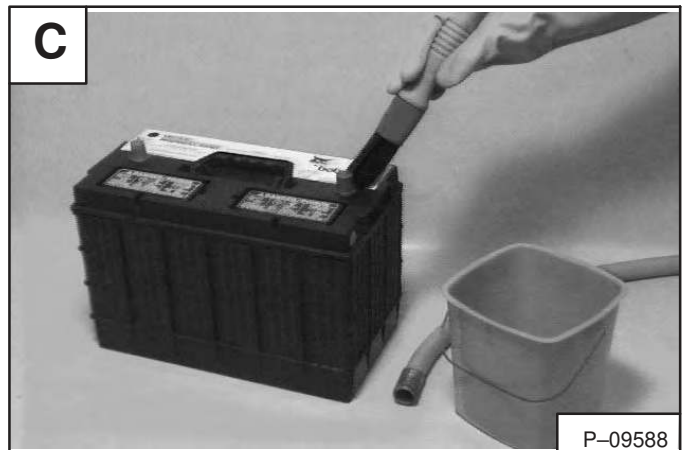
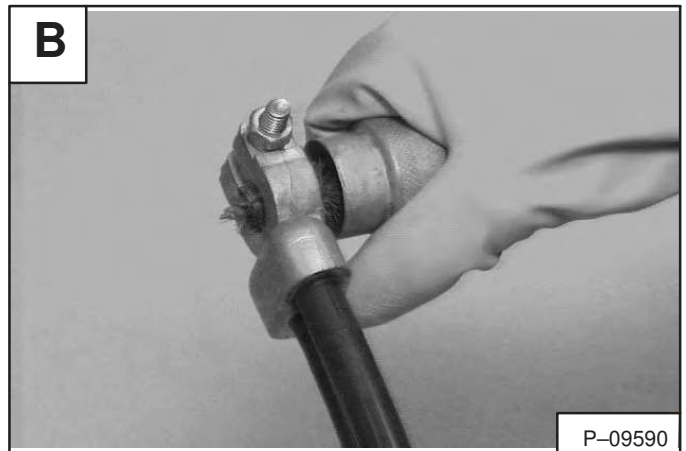
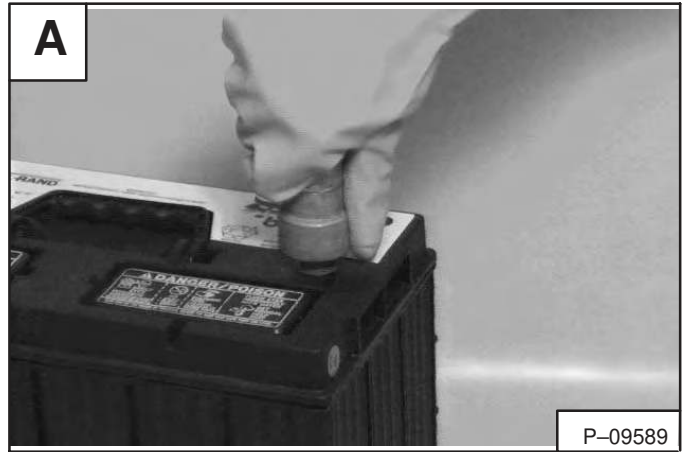

## STARTER (Cont'd)

### Disassembly and Assembly

Disconnect the wire from the magnetic switch [A].

**Assembly:** Tighten the nut to 52–86 in.-lbs. (5,9–9,7 Nm) torque. Securely put the rubber boot over the terminal.

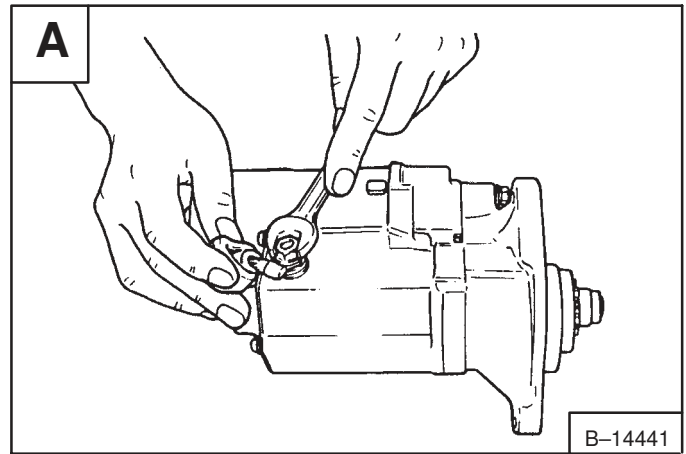

Remove the through bolts from the drive end frame [B].

**Assembly:** Tighten the through bolts to 60–104 in.-lbs. (6,8–11,8 Nm) torque.

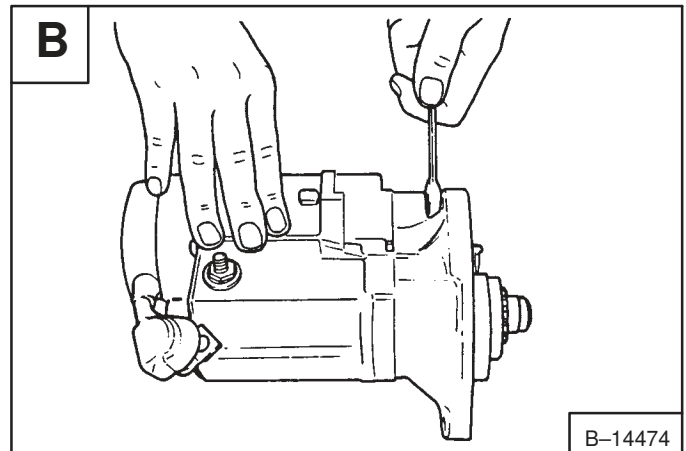

Remove the field windings housing from the magnetic switch [C].

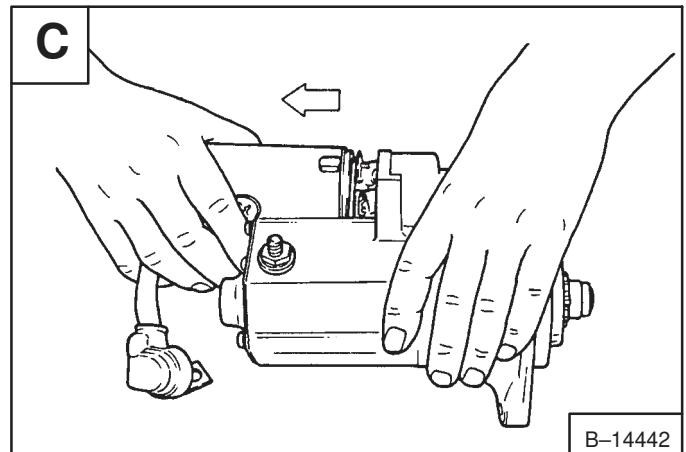

**Assembly:** When installing the field windings housing to the magnetic switch, engage the tab (Item 1) [D] on the field windings housing with the notch in the magnetic switch.

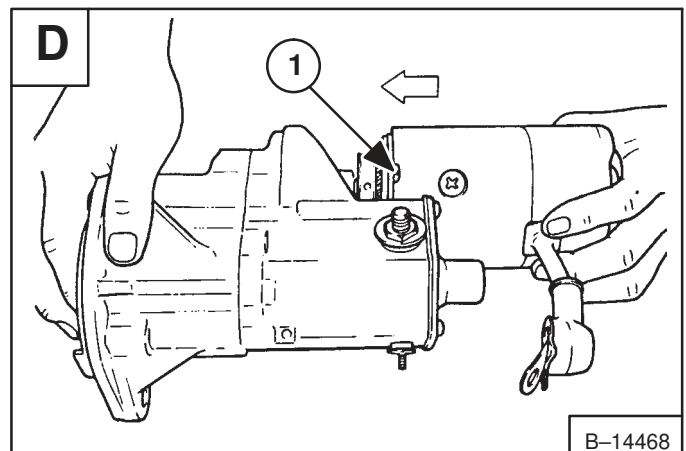

## FRONT LIGHTS

### Removal and Installation

The front lights are mounted in the upper corners of the operator cab [A].



Pry the rubber light mount free from the operator cab [B].

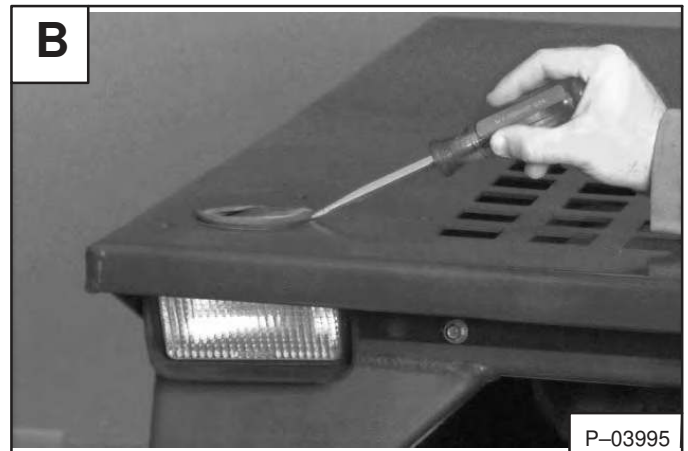

Pull the light down and remove the three mounting bolts (Item 1) [C] from the instrument panel.

Disconnect the front light connector from the instrument panel. Remove the front light from the operator cab.

Reverse the removal procedure to install the front light.

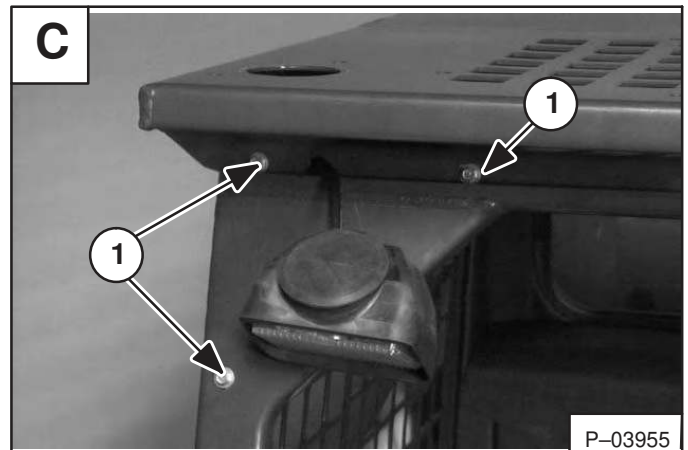

## BLOWER HOUSING/FAN GEARBOX

### Removal And Installation

Raise the lift arms and install an approved lift arm support device. (See Page 1-1.)

Raise the operator cab. (See Page 1-1.)

Remove the operator cab gas cylinder on the left side of the loader. (See Page 5-1.)

Disconnect the operator cab wiring harness from the engine wiring harness (Item 1) [A].

Remove the harness clamp bolt (Item 2) [A].

Lay the electrical harness down for clearance at the blower housing.

Remove the hydraulic/hydrostatic filter mounting bracket assembly. (See Page 2-1.)

Remove the fan drive belt.

Remove the four mounting bolts (Item 1) [B] and spacer tubes (two spacer tubes are outside the housing and two inside the housing).

**NOTE:** Remove the two rear mounting bolts first.

**Installation:** Tighten the mounting bolts to 25–28 ft.-lbs. (34–38 Nm) torque.

Slide the blower housing forward and remove the fan/fan gearbox assembly [C].

Remove the blower housing.

See Page 7-15 for Disassembly of the Fan Gearbox

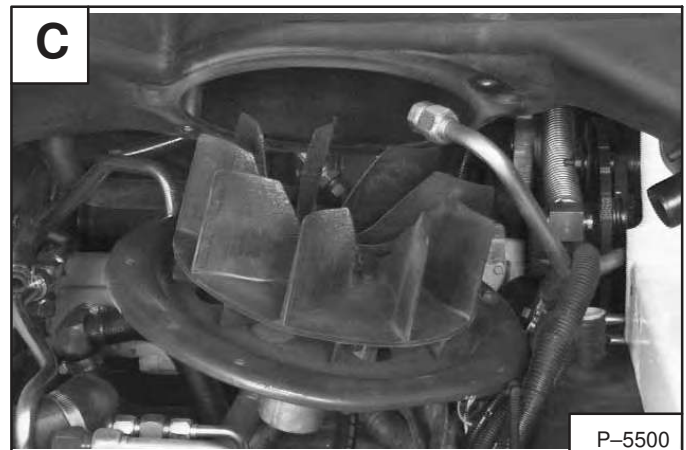
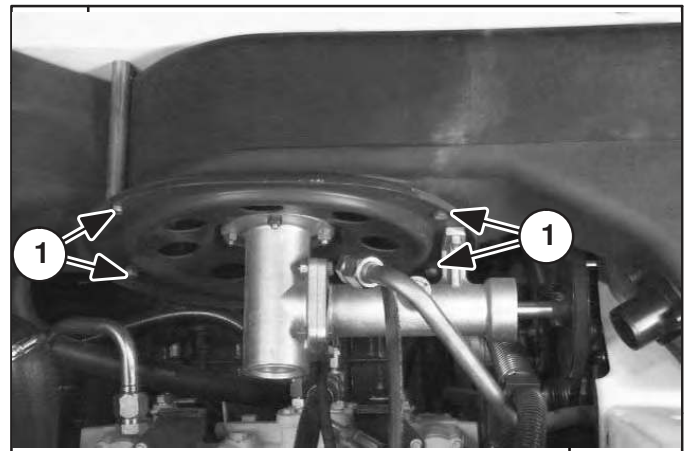
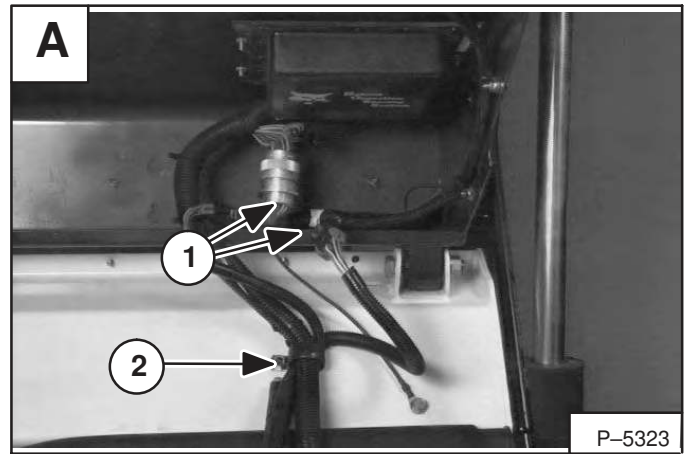

## FAN GEARBOX (Cont'd)

### Disassembly (Cont'd)

Press the bearing, shims and gear from the shaft **[A]**.

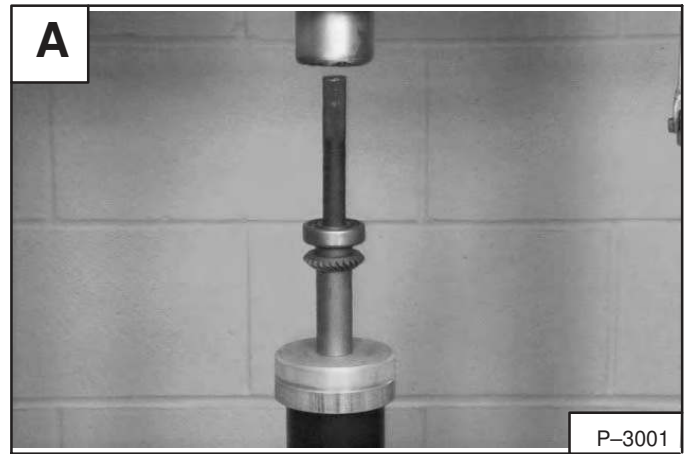

Remove the key (Item 1) **[B]** from the shaft.

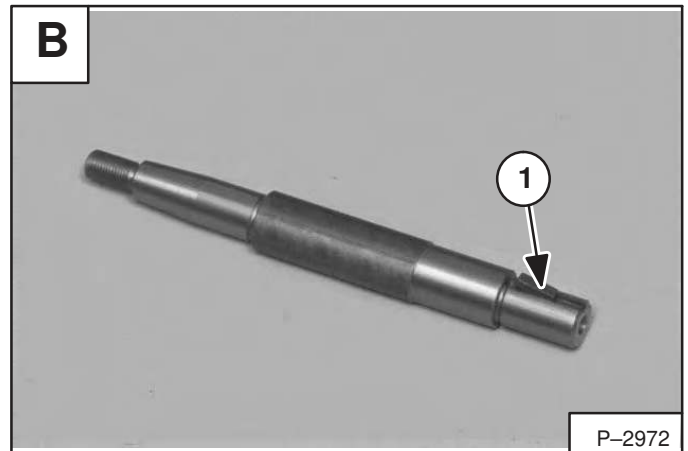

## ENGINE/HYDROSTATIC PUMP ASSEMBLY (Cont'd)

### Removal And Installation (Cont'd)

Remove the bolt and nut (Item 1) [A] at the right front engine mount.

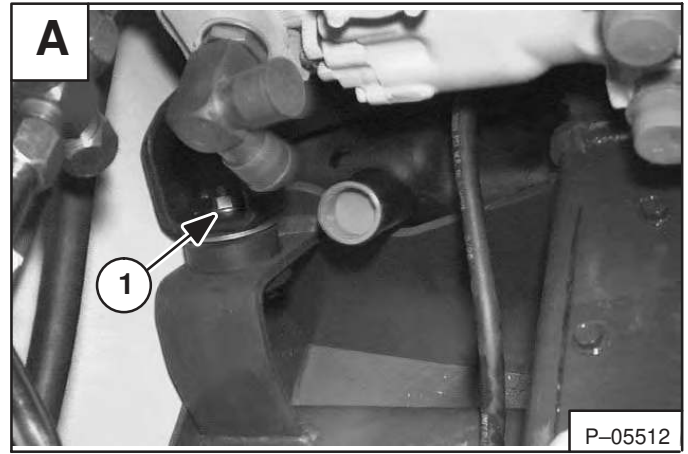

Remove the bolt (Item 1) [B] at the left front engine mount.

**NOTE:** The nut (Item 2) [B] is held in the housing and will not turn.

**Installation:** Tighten the mounting bolts and nuts to 61–69 ft.-lbs. (83–94 Nm) torque.

Disconnect fuel level sender wire connector at the fuel tank.

Disconnect the fuel return hose at the fuel tank.

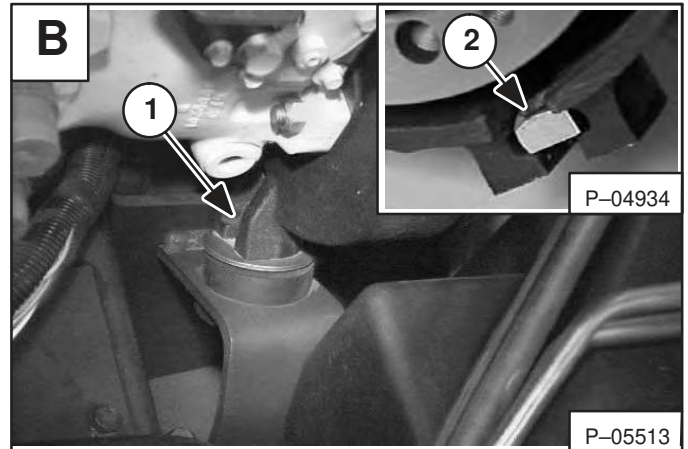

Disconnect the engine ground cable (Item 1) [C].

Disconnect the positive (+) cable (Item 2) [C] at the starter.

Remove the battery. (See Page 6–1.)

Remove the engine muffler. (See Page 7–6.)

Remove the air cleaner housing. (See Page 7–7.)

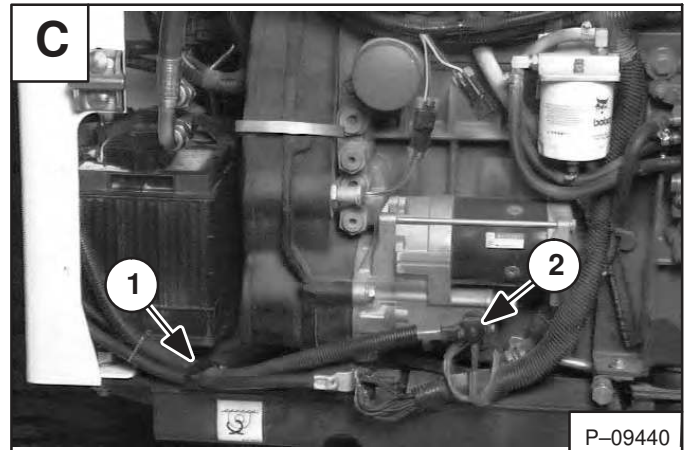

Disconnect the hoses (Item 1) [D] at the engine and drain the oil from the oil cooler into a container.

**NOTE:** Measure the amount of oil removed from the oil cooler and/or engine. Add the same amount of oil to the engine crankcase when adding engine oil.

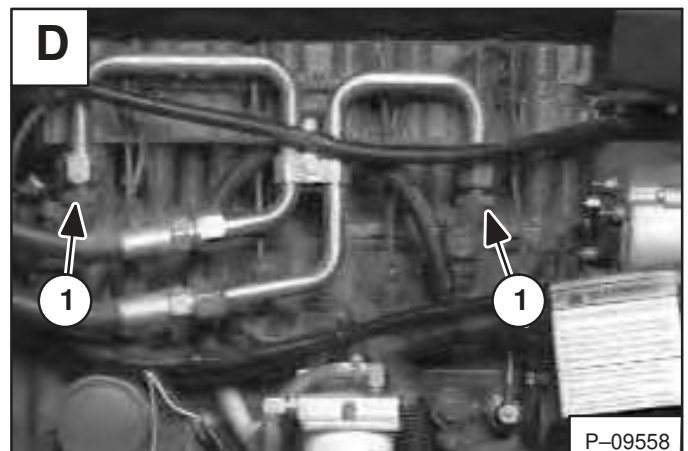

## FUEL INJECTION PUMP

### Description

The injection pump(s) contain parts which have a very close tolerance and its operation has a direct effect on the performance of the engine.

# IMPORTANT

Do not attempt to maintain or adjust unless you are trained and have the correct equipment.

I-2028-0289

### Removal

Remove the fuel tubeline (Item 1) [A] to the fuel injection pumps (Item 2) [A].

Disconnect the respective high pressure fuel line (Item 3) [A] from the injection pump to be removed and fuel injector.

Use a flare nut wrench (Item 1) [B] to loosen the high pressure fuel line nut.

# IMPORTANT

Do not bend the high pressure fuel injection tubes when removing or installing them.

I-2029-0289

Remove the two mounting nuts (Item 1) [C] from the injection pump.

Remove the fuel injection pump (Item 1) [D].

Remove the shim (Item 2) [D].

**NOTE:** The shim(s) are used to time the injection pump, keep the same thickness for each injection pump.

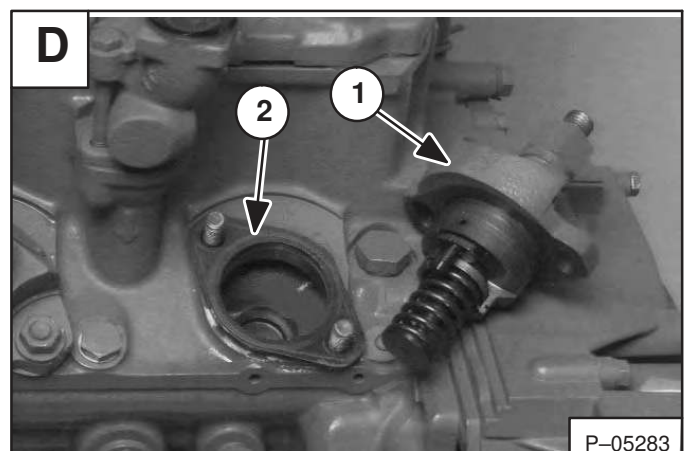
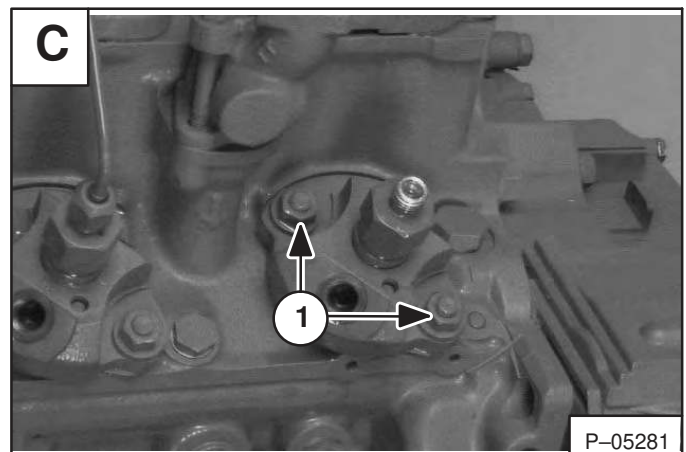
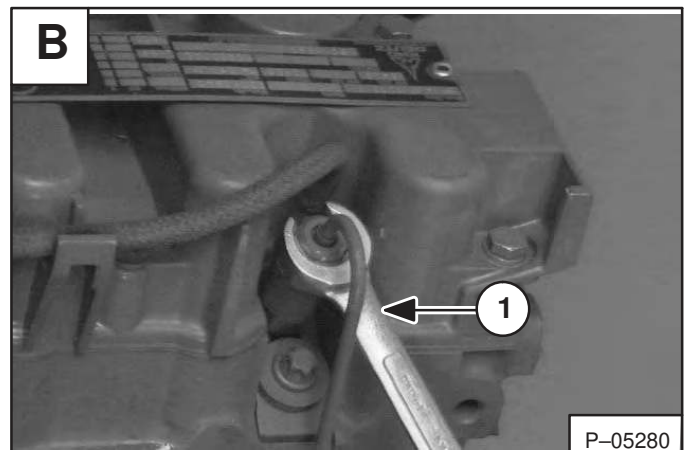
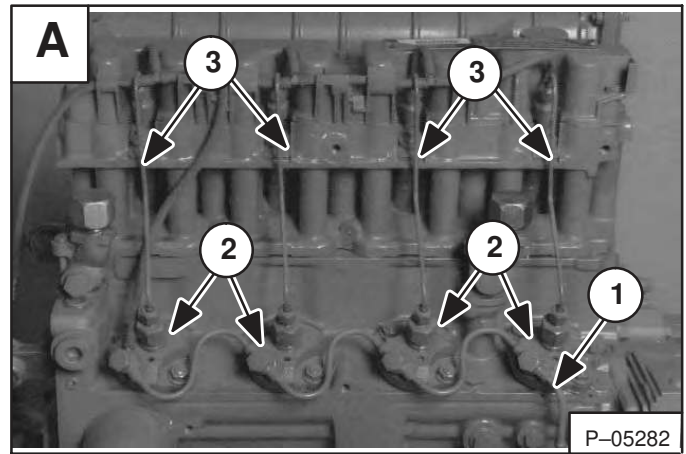

## TIMING BELT (Cont'd)

### Installation

**NOTE:** Remove the fuel injectors (Page 7-43) and rocker brackets from the cylinder head. This will let the crankshaft turn easier for timing belt installation.

The camshaft plug is located at the rear of the engine block (Item 1) [A] on the fuel injection pump side. (See Page 7-58, for the correct tool.)

Remove the plug.

Rotate the camshaft until the notch in the camshaft can be seen through the plug hole.

Install the timing tool (Item 2) [A] and tighten.

The crankshaft plug is located at the front of the engine block (Item 1) [B] on the exhaust manifold side.

Remove the plug.

Rotate the crankshaft until the flat spot on the crankshaft throw can be seen through the plug hole. Turn the crankshaft back a small amount. Install the timing tool (Item 2) [B] and tighten.

Rotate the crankshaft until it hits the timing tool and stops.

Loosen the nut at the camshaft gear [C]. (See Page 7-58, for correct tool.)

Install the new timing belt.

Measure the distance from the edge of the belt to the front cover surface [D].

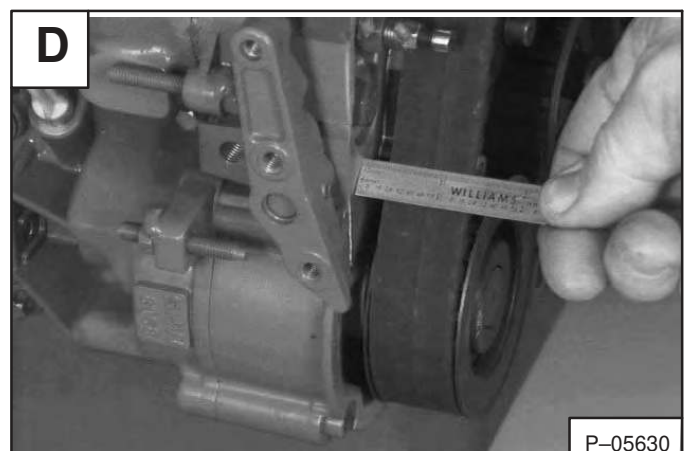
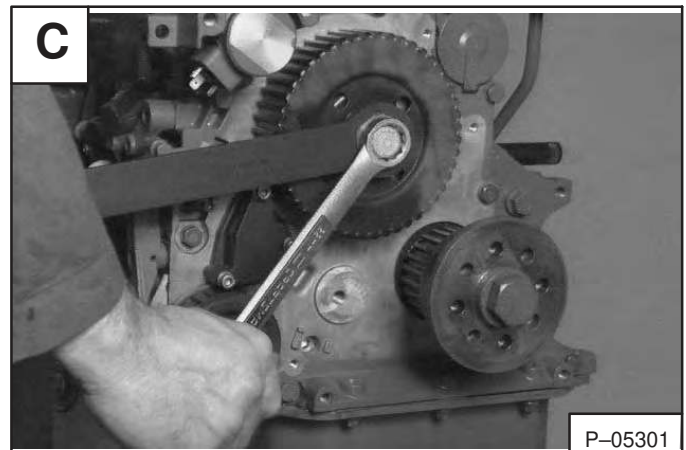
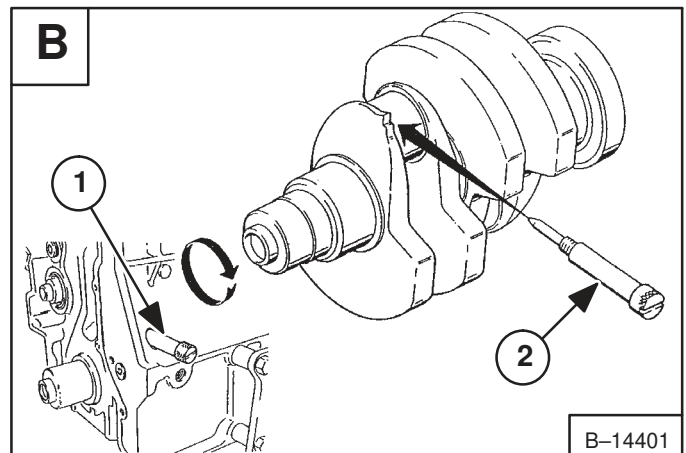
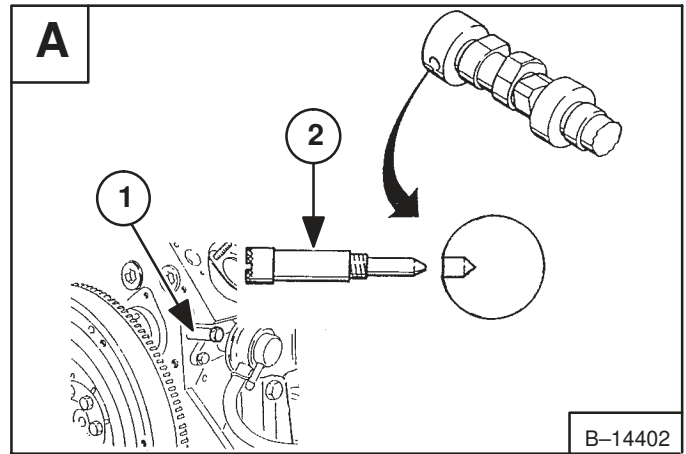

## RECONDITIONING THE ENGINE

### Disassembly

Remove the starter. (See Page 6–1.)

Remove the alternator. (See Page 6–1.)

Drain the oil from the engine oil pan.

Remove the turbocharger. (See Page 7–113.)

Remove the exhaust manifold.

Remove the intake manifold.

Remove the fuel injection pumps. (See Page 7–39.)

Remove the fuel injectors. (See Page 7–43.)

Remove the oil filter.

Remove the fuel filter & fuel lift pump **[A]**.

Remove the valve cover.

Remove the rocker arms and brackets **[B]**.

Remove the push rods **[C]**.

Remove the cylinder head bolts **[D]**.

Remove the cylinder head.

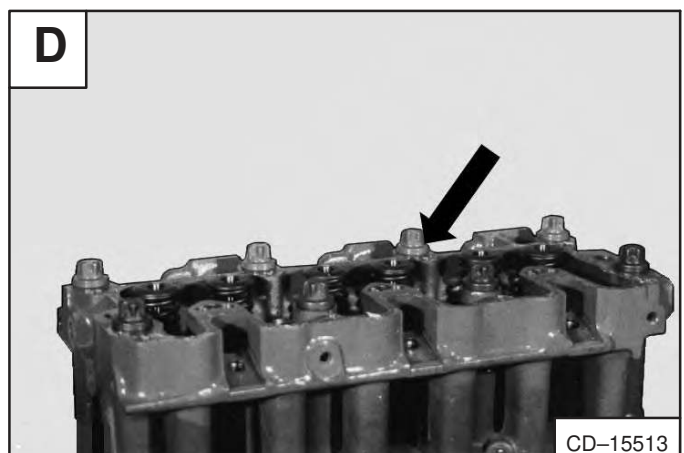
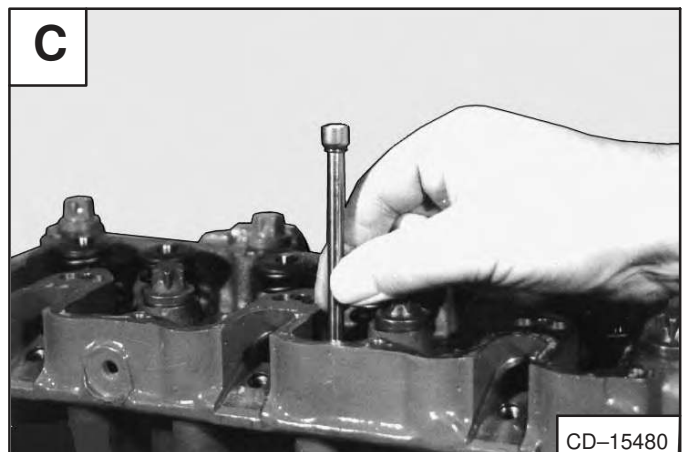
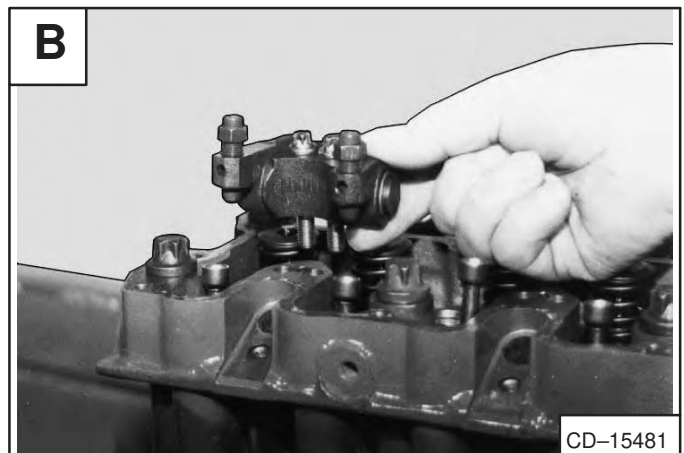
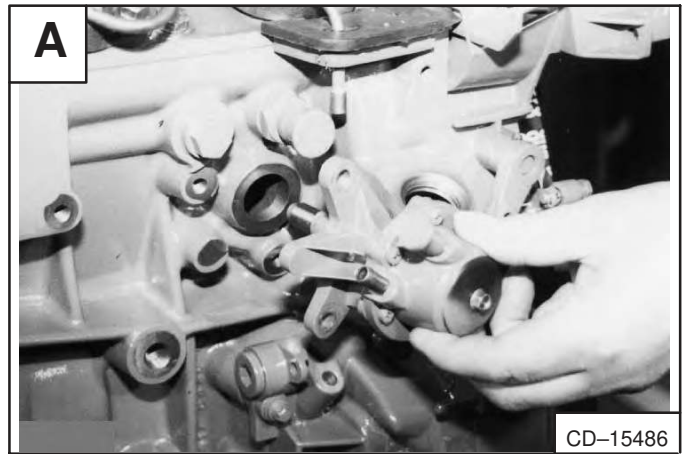

## RECONDITIONING THE ENGINE (Cont'd)

### Assembly (Cont'd)

Compare actual dimension with the dimension listed [A]:

Specifications:

Piston Class A ..... 7.732–7.736 inch  
(196,39–196,49 mm)

**NOTE: If the crankshaft is undersize, 0.005 inch (0,125 mm) must be added to the dimension listed.**

Install the connecting rod bearing halves into the connecting rod [B].

Before installing piston/connecting rod assembly, make sure the piston ring gaps are staggered as shown in Fig. [C].

Install a piston ring compressor on the piston rings.

Install the piston/connecting rod assembly into the engine block [D].

**NOTE: The flywheel symbol on the piston must be toward the flywheel.**

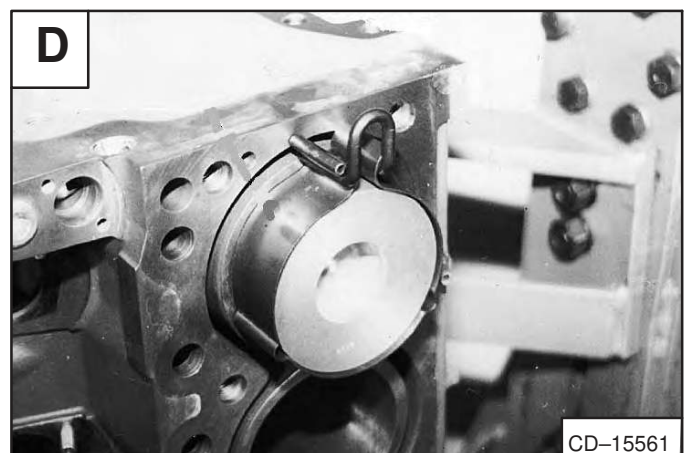
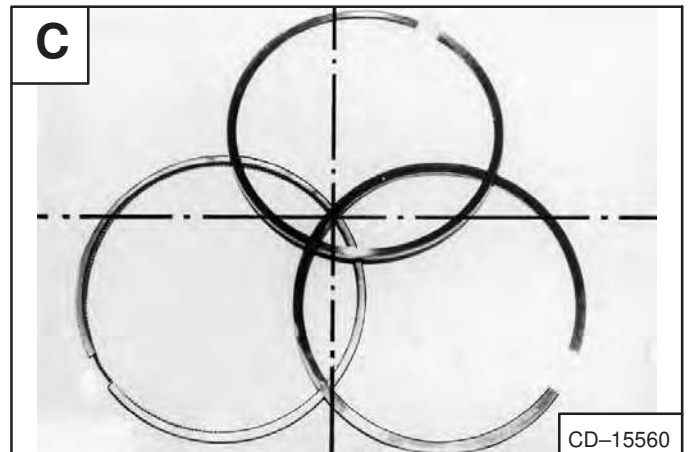
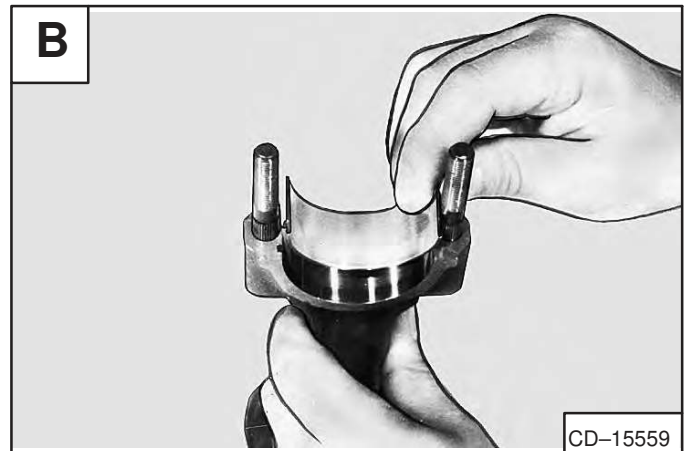
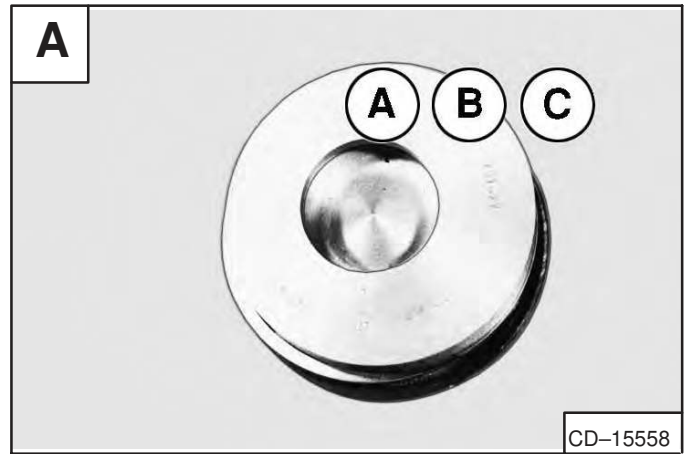

## CAMSHAFT BEARINGS

### Checking

Check the camshaft bearing bushings at points (1) and (2) in the planes of (a) and (b) [A].

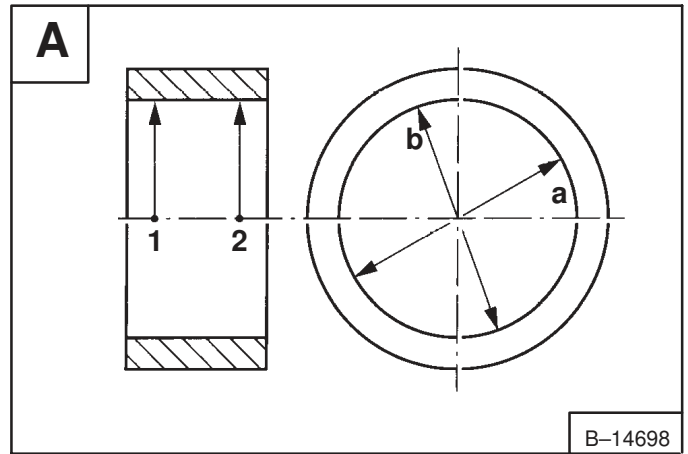

B-14698

Check the camshaft bushings using a gauge [B].

Inner Diameter ..... 2.126 + 0.002 inch  
(54 + 0,054 mm)  
Wear Limit ..... 2.129 inch (54,08 mm)

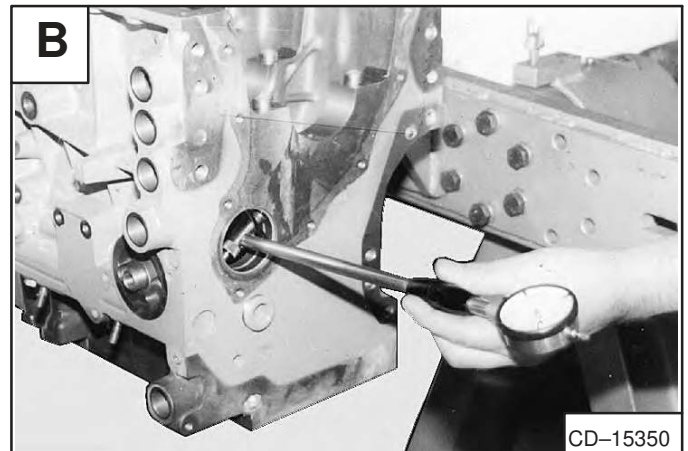

CD-15350

### Removal And Installation

Remove all the camshaft bearing bushings using a camshaft bushing removal tool as needed [C].

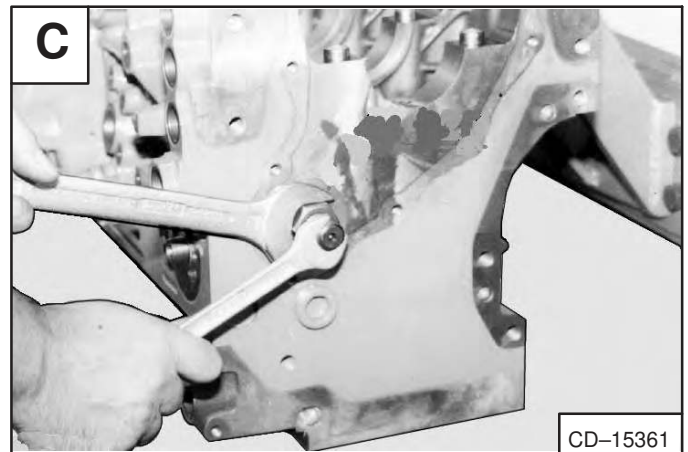

CD-15361

Use the dimensions in figure [D] to install the camshaft bushings.

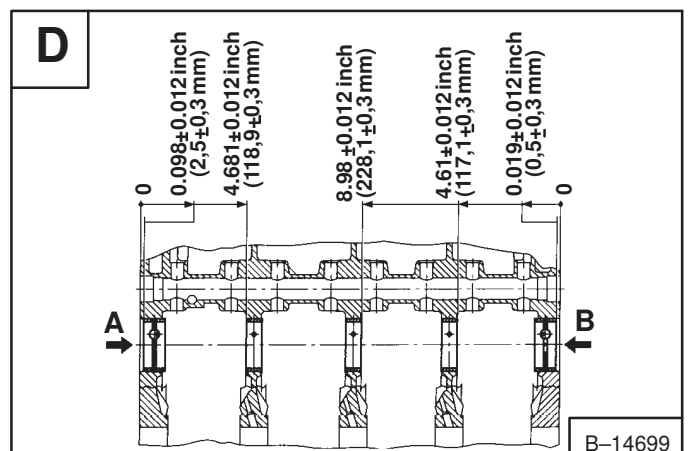

B-14699

## CONNECTING ROD

### Checking The Connecting Rod

When checking the connecting rod large and small end, measure at the points (1) and (2) and in planes (a) and (b) [A].

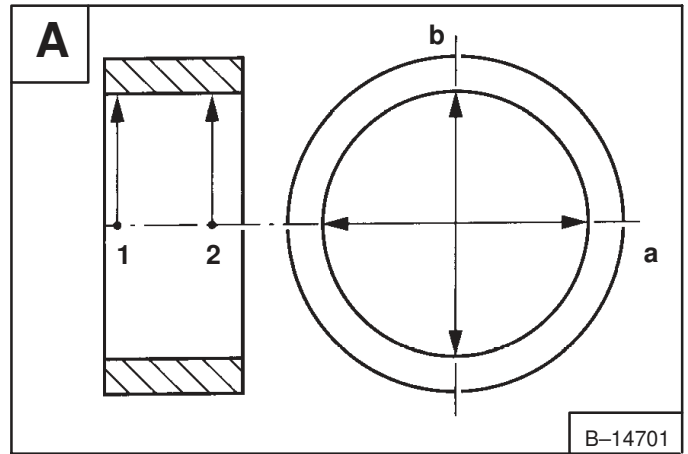

B-14701

Check the small end bushing [B].

Specifications:

I.D. of Small End Bushing . . . . . 1.181  $\begin{matrix} +0.00014 \\ +0.00009 \\ +0.0035 \\ (30 +0.0025 \text{ mm}) \end{matrix}$  inch

Wear Limit Bushing Clearance . . . . . 0.003 inch (0,08 mm)



CD-15447

Replace small end bushing as needed [C].

Bore for Small End Bushing . . . . . 1.299  $\begin{matrix} +0.0008 \\ (33 +0,02 \text{ mm}) \end{matrix}$  inch

O.D. of Small End Bushing . . . . . 1.299  $\begin{matrix} +0.004 \\ +0.0027 \\ (33 +0,110 \\ +0,070 \text{ mm}) \end{matrix}$  inch

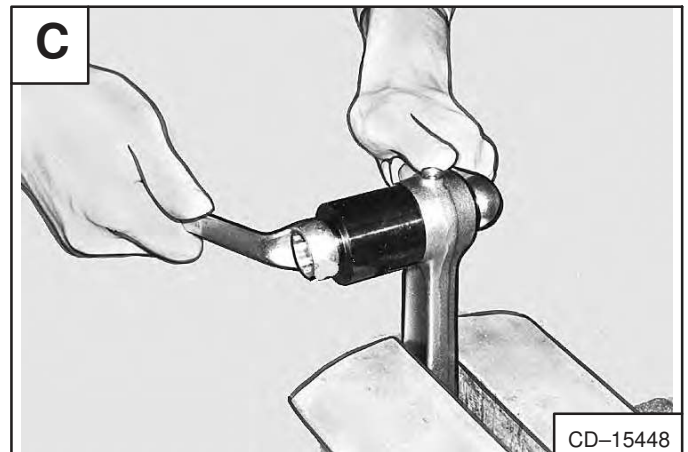

CD-15448

Press in the small end bushing, make sure the lubrication holes are in alignment [D].

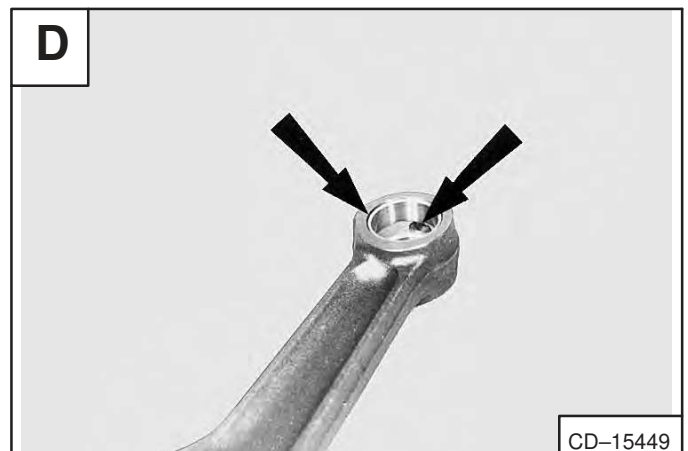

CD-15449

**FRONT COVER (Cont'd)**

**Disassembly (Cont'd)**

Remove the centrifugal governor **[A]**.

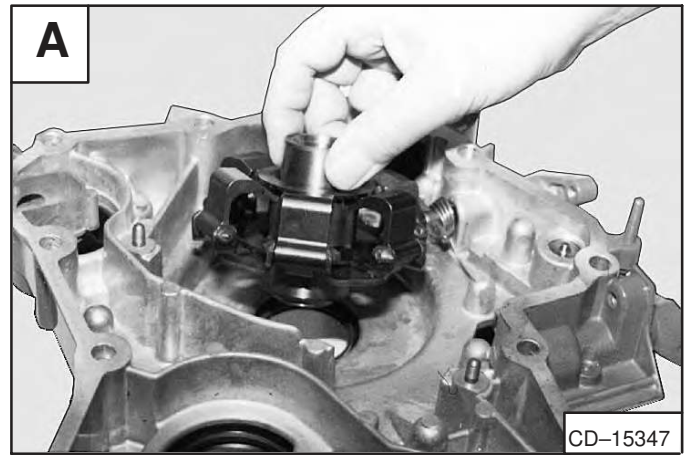

Remove the camshaft seal **[B]**.

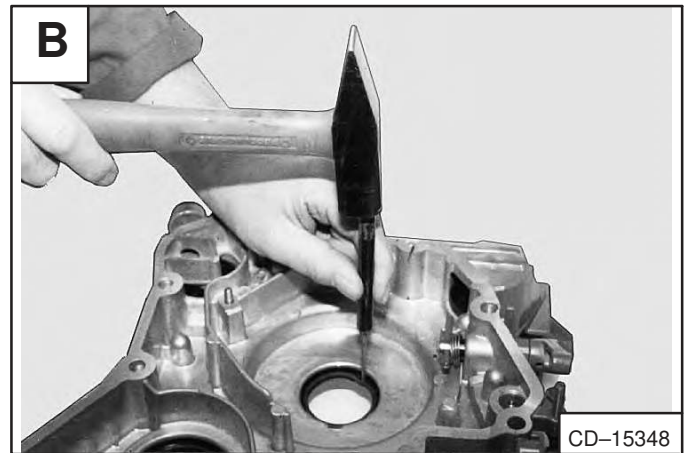

Remove the crankshaft seal **[C]**.

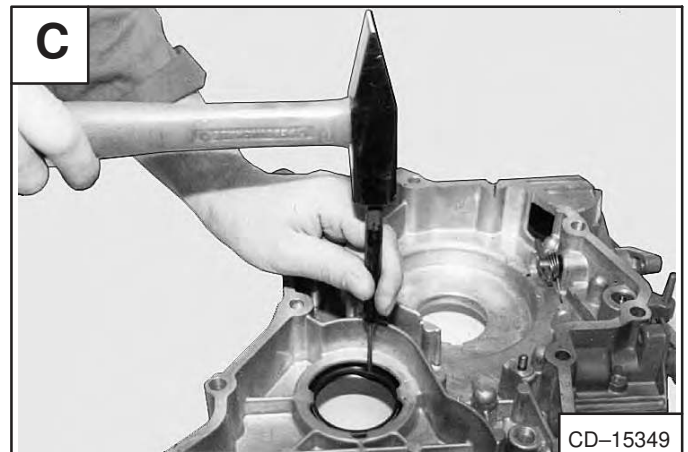

Disconnect the spring **[D]**.

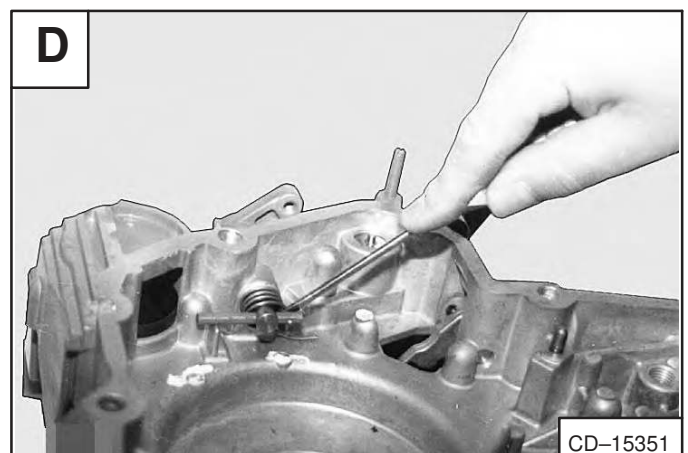

## FRONT COVER (Cont'd)

### Assembly (Cont'd)

Inspect the governor plate for wear **[A]**.

Replace as needed.

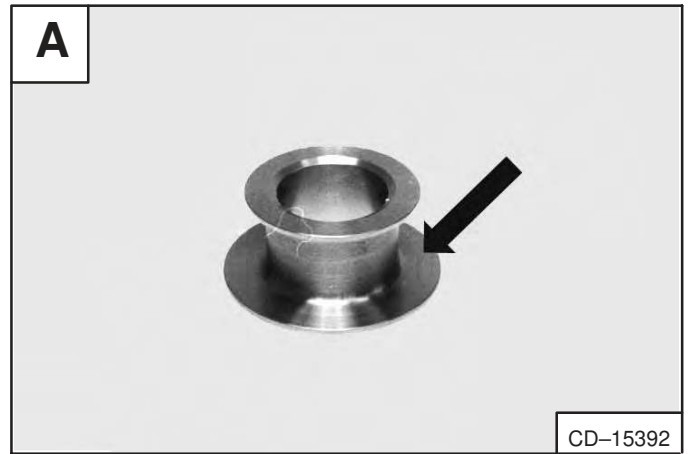

Assemble the governor plate with the centrifugal governor **[B]**.



Install centrifugal governor assembly into the front cover **[C]**.

Be careful not to damage the shaft seal.

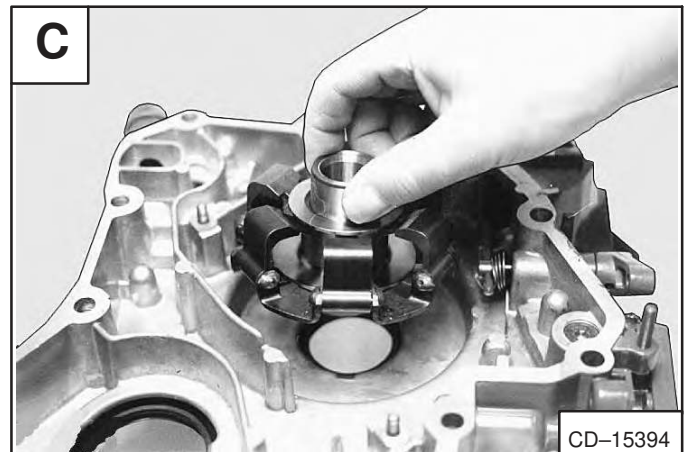

Inspect roller lever, shaft and idling lever wear **[D]**.

Replace the parts as needed.

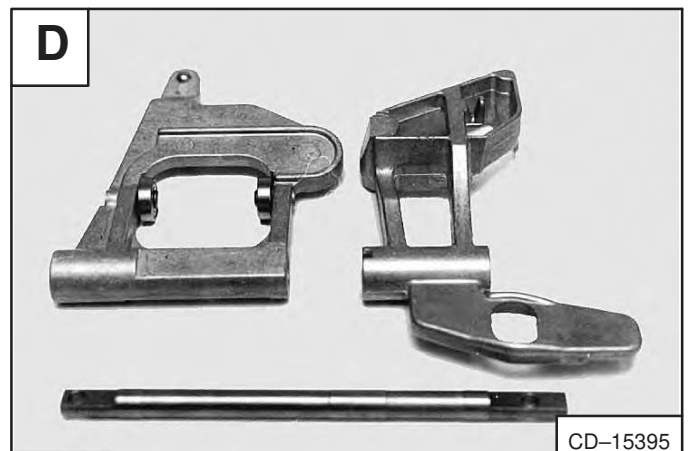

## TURBOCHARGER (Cont'd)

### Assembly

Make sure all the parts are clean. Put oil on the following parts before assembling:

- Bearing seat of the shaft
- Bearings
- Thrust bearing
- Finger sleeve
- Oil deflector ring
- Thrust ring
- Piston rings
- Spacer sleeve

Install the bearings and snap rings in the bearing housing [A] & [B].

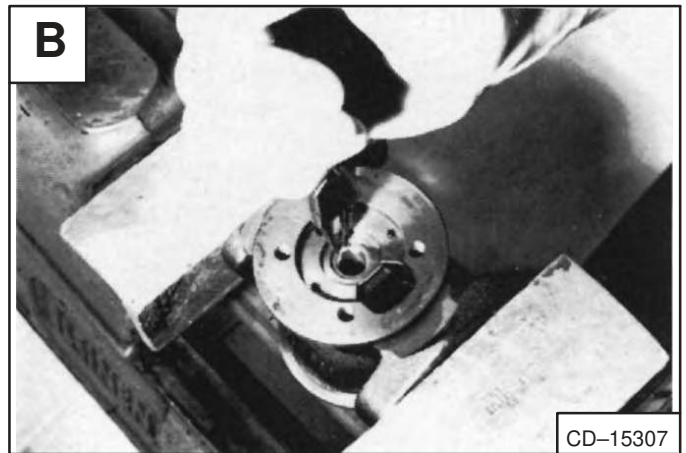
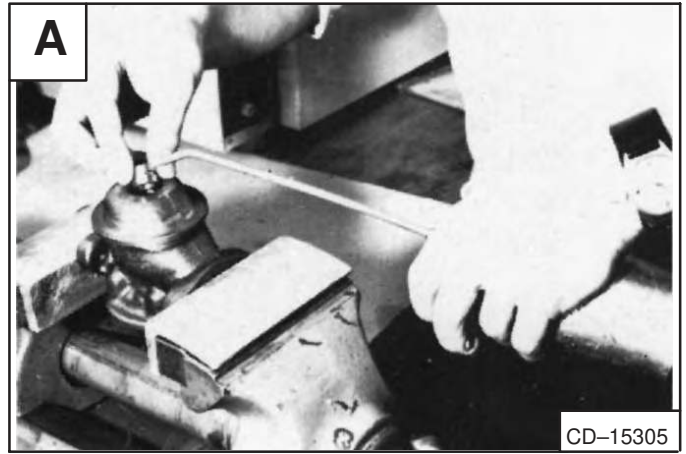

Clamp the shaft and turbine wheel assembly in a vice using jaw plates. Install the two piston rings on the shaft.

Position the ring gaps at 180° to each other [C].

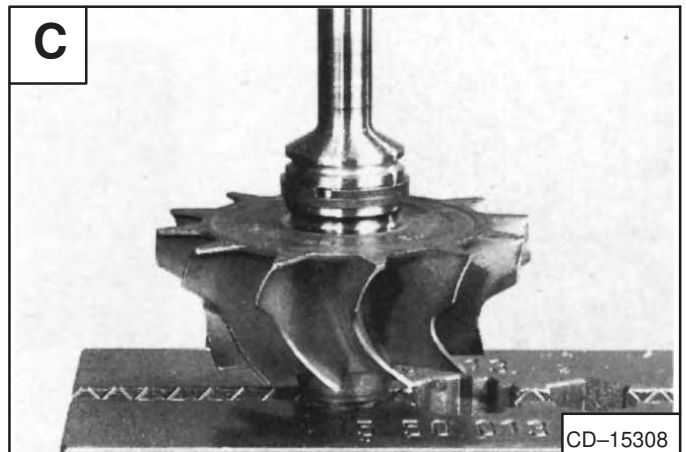

Install the heat shield on the shaft and turbine wheel assembly [D].

**NOTE:** Install a piece of shim, 0.039 inch (1,0 mm) thick between the heat shield end turbine wheel to make sure that the piston rings are guided inside the bearing housing bore.

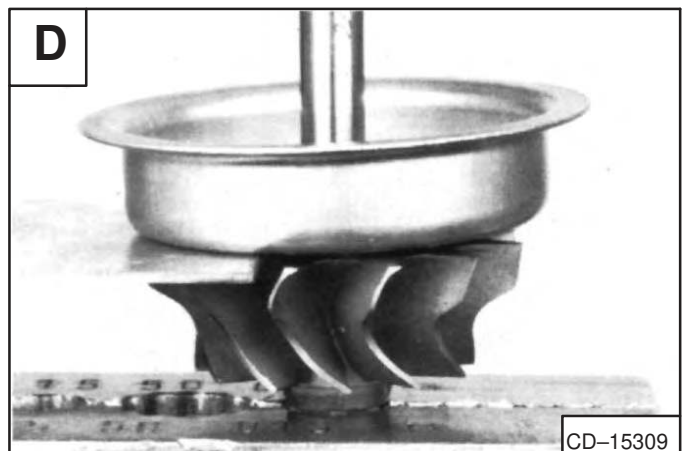

## SYSTEMS ANALYSIS

	<b>Page Number</b>
BICS™ CONTROL VALVE Removal And Installation .....	8-19
BICS™ SYSTEM CONTROLLER Controller Test .....	8-11
Removal And Installation .....	8-10
BOSS® DIAGNOSTIC TOOL Procedure .....	8-21
BOSS® INSTRUMENT PANEL Removal And Installation .....	8-27
BOBCAT INTERLOCK CONTROL SYSTEM (BICS™) Inspecting The BICS™ System Controller (Engine STOPPED – Key ON) .....	8-3
Inspecting Deactivation Of The Auxiliary Hydraulics System (Engine STOPPED – Key ON) .....	8-3
Inspecting The Lift Arm By-Pass Control .....	8-3
Inspecting The Seat And Seat Bar Sensors (Engine RUNNING) .....	8-3
Inspecting The Traction Lock (Engine RUNNING) .....	8-3
Maintenance .....	8-3
Troubleshooting Chart .....	8-4
Troubleshooting Guide .....	8-5
ELECTRICAL/HYDRAULIC CONTROLS REFERENCE Controls Identification Chart .....	8-33
LIFT LOCK BY-PASS VALVE Disassembly And Assembly .....	8-18
Removal And Installation .....	8-17
MONITOR SERVICE CODES Alphabetic Codes .....	8-22
Numeric Codes .....	8-22
Service Codes .....	8-23
OPERATION SENSING SYSTEM UNIT Removal And Installation .....	8-26
PWM CONTROL HANDLE Handle Test .....	8-31
PWM ELECTRIC SOLENOID Solenoid Coil Testing .....	8-31
PWM MODULE (S/N 514111443 – 514114999) Description .....	8-28
PWM TROUBLESHOOTING (S/N 514111443 – 514114999) Chart .....	8-30
Conditions .....	8-29
RPM SENSOR Adjustment .....	8-21
SEAT BAR SENSOR Removal And Installation .....	8-12
Seat Bar Sensor Test .....	8-13

SYSTEMS  
ANALYSIS

Continued On Next Page

## BICS™ SYSTEM CONTROLLER (Cont'd)

### Controller Test

Sensor Tester (JME1428) is necessary for the following procedure:

Turn the key to the ON position. **DO NOT START THE ENGINE.**

After completing the procedure for the Seat sensor test or the Seat Bar sensor test, do the Controller test. Refer to Page 8-3 for correct procedures to do the Seat Bar sensor test or the Seat sensor test.

Move the toggle switch (Item 1) [A] on the sensor tester (Item 2) [A] to the **Present** position.

If the controller is working correctly, the Seat light (Item 1) [B] on the controller will illuminate when the tester is connected to the Seat sensor.

When the tester is connected to Seat Bar sensor, the Seat Bar light (Item 1) [C] will illuminate if the controller is working correctly.

Move the toggle switch (Item 1) [D] on the sensor tester (Item 2) [D] to the **Absent** position.

The Seat light (Item 1) [B] or the Seat Bar light (Item 1) [C] should go off.

If the tests above fail, there is a problem with the BICS system controller or the wiring harness.

Refer to Page 8-3 for the correct procedure to inspect the BICS System Controller.

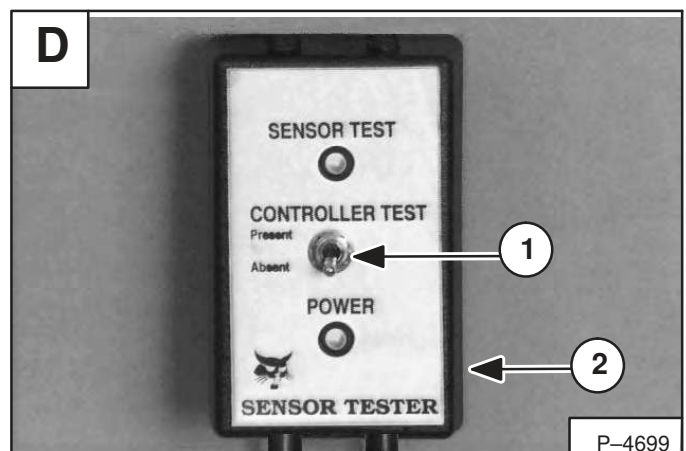
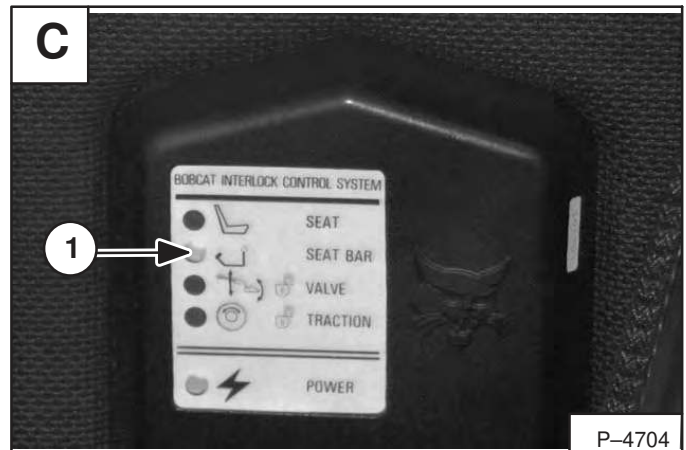
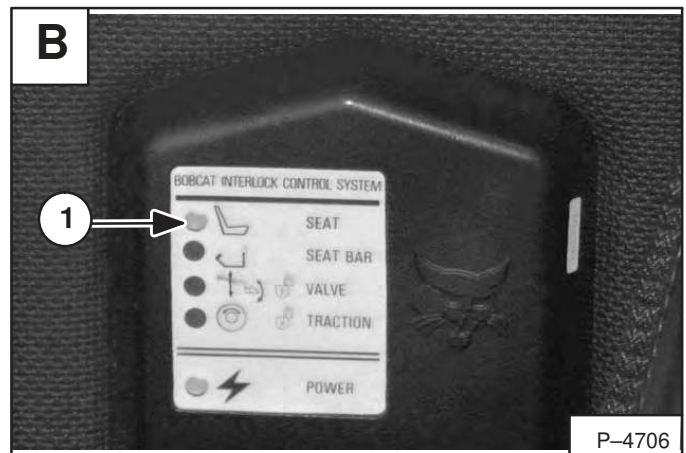
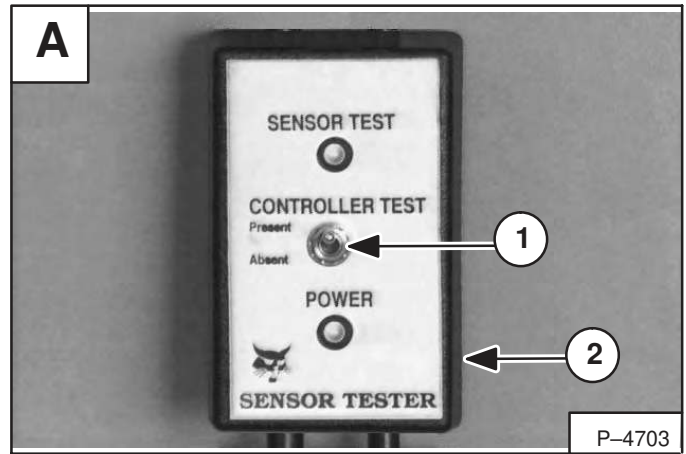

## BOSS® DIAGNOSTIC TOOL

### Procedure

The tool listed will be needed to do the following procedure:

MEL1400 – Diagnostic Tool

Stop the engine.

Lift and block the loader. (See Page 1–1.)

Remove the dust cap from the diagnostic connector plug. Connect the diagnostic tool plug (Item 1) [A] into the loader connector.

Use the instructions from the BOSS Operation & Maintenance Manual to make service checks of BOSS system operating unit and other components [A].

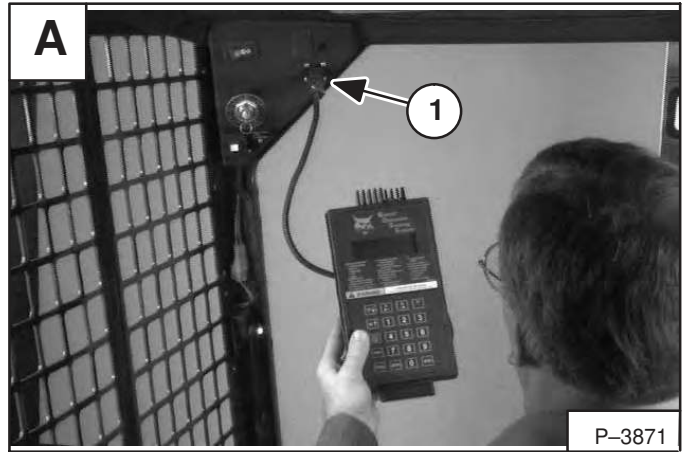

## SENDER AND SENSOR

### Service Checks

Use the following information when checking the senders and sensor with a volt/ohmmeter:

#### Components

#### Value

#### TEMPERATURE SENDER

70° F. (21° C.)	970 ohms
80° F. (27° C.)	1013 ohms

#### ENGINE OIL PRESSURE SENDER

0 PSI	3 ohms Max.
6 PSI (41 kPa)	7 ohms Min.
50 PSI (345 kPa)	49 ohms
70 PSI (483 kPa)	59 ohms

#### TRANSMISSION CHARGE PRESSURE SENDER

0 PSI	0–5 ohms
100 PSI (690 kPa)	58 ohms
130 PSI (896 kPa)	75 ohms
150 PSI (1034 kPa)	87 ohms

#### FUEL SENDER

Full	30 ohms
Empty	270 ohms

## RPM SENSOR

### Adjustment

Continuity Resistance of 3000–3500 ohms.

Disconnect the connector [B] from the engine harness.

Loosen the jam nut (Item 1) [B] on the RPM sensor.

Turn the RPM sensor (Item 1) [C] in until it makes contact with the engine flywheel.

Turn the jam nut until it contacts the flywheel housing. The jam nut should not be tightened, it needs to turn with the RPM sensor when the sensor is turned back out for adjustment.

Turn the RPM sensor and the jam nut out from the flywheel. Set a clearance of 0.050 inch (1,27 mm) between the jam nut and the housing with a feeler gauge [C].

Retighten the jam nut.

**NOTE: The plastic tip is used as a gauge to set a new RPM SENSOR. The plastic tip is designed to come off after the engine is started.**

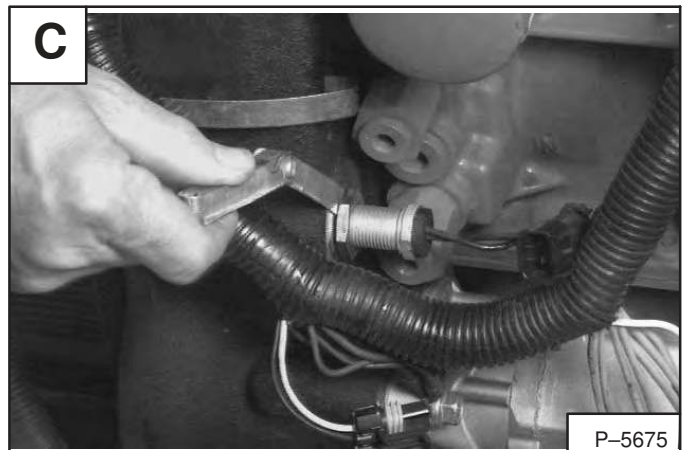

## PWM CONTROL HANDLE

### Handle Testing

The right side steering lever handle switch (Item 1) [A] controls the proportional flow to front auxiliary. Test the switch with a Ohm test meter.

Disconnect the handle switch harness from the controls harness. Use the chart below to test the handle switch.

**Handle Switch Position**

Test between handle wires	Full Left	Center	Full Right
White/Black & White	No Test	4.8–5.2 Ohms	No Test
White/Red & White	1.3–1.5 Ohms	2.6–2.8 Ohms	3.8–4.0 Ohms
White/Red & White/Black	3.8–4.0 Ohms	2.6–2.8 Ohms	1.3–1.5 Ohms

**NOTE:** Push the switch gradually from center to either left or right. The Ohm reading must change gradually. Replace the handle switch assembly if required.

## PWM ELECTRIC SOLENOID

### Solenoid Coil Testing

The front auxiliary solenoid valves (Item 1) [B] are located in the hydraulic control valve. Test the solenoid coils with a Ohm test meter.

Disconnect the coil from the controls harness. The correct reading is 1–5 Ohms.

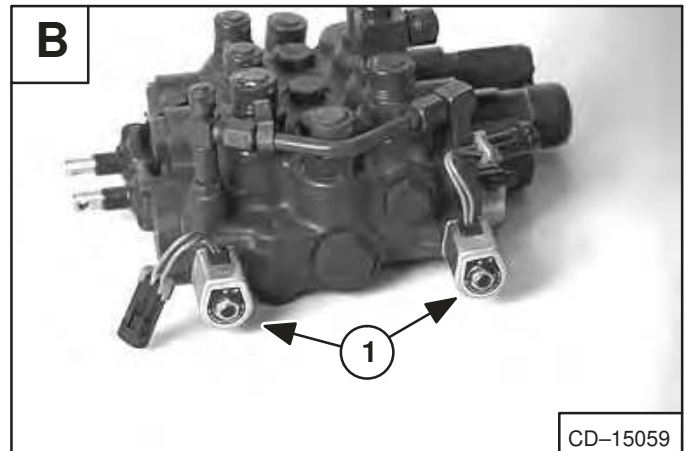
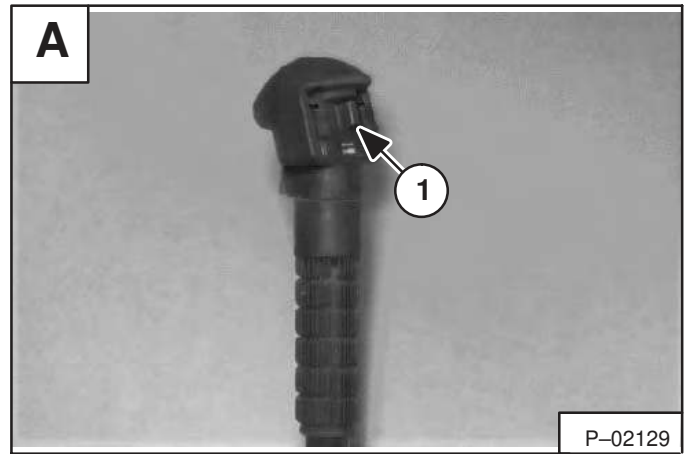

## ENGINE SPECIFICATIONS (Cont'd)

### Engine Torque Specifications

Description	Ft.-Lbs.	Nm
Air Intake Manifold Bolts (M8 Torx) .....	15	20
Adapter Housing Bolts (M12) .....	21-24	28-33
Camshaft Bolt (M14 x 1,5 x 110) .....	22	30
Plus 210 degrees		
Camshaft Thrust Washer Bolt (M8) .....	15	20
Connecting Rod Cap Nuts .....	22	30
Plus 60 degrees, 60 degrees = 120 degrees		
Crankcase Screw Plugs (M18) .....	37	50
(M24) .....	82	111
(M30) .....	12-15	16-20
Crankshaft Gear Mount Bolt .....	95	130
Plus 210 degrees, 10 degrees = 220 degrees		
Cylinder Head Bolts Step 1 .....	22	30
Step 2 .....	59	80
Step 3 .....	118	160
Plus 90 degrees		
Exhaust Manifold Bolts (M10) .....	30	40
Exhaust Turbocharger Nuts (M8) .....	22	30
Flywheel Bolts .....	22	30
Plus 60 degrees, 30 degrees = 90 degrees		
Front Cover Bolts .....	15	20
Front Mount Foot Bolts M14 x 55) .....	38	52
Fuel Lift Pump Bolts (M8 Torx) .....	15	20
Glow Plug .....	15-18	20-24
Injector Cap Nut .....	35	47
Injection Pump Nuts .....	15	21
Main Bearing Bolts .....	37	50
Plus 60 degrees, 45 degrees = 105 degrees		
Oil Pan Bolts (M8) .....	15	20
Oil Pan Drain Plug .....	40	54
Oil Pump Bolts (M8 Torx) .....	16	22
Oil Press. Control Valve Screw Plug .....	82	111
Oil Return Line Cap Nut .....	13-14	18-19
Oil Suction Pipe .....	16	22
Oil Temp. Switch .....	21	28
Rocker Arm Bracket Bolts (M8 Torx) .....	15	20
Rear Cover Bolts .....	15	20
Rear Mounting Foot Bolts (M12) .....	23	31
Starter Carrier Bolts (M12) .....	15-18	20-24
Starter Fastening Bolts .....	25-28	34-38
Thermostat Housing Screw Plug (M38) .....	82	111
Timing Belt Tensioner Pulley Nut .....	33	45
V-Belt Pulley Bolts (M10) .....	30-36	41-49

CLICK HERE TO **DOWNLOAD** THE COMPLETE MANUAL

- Thank you very much for reading the preview of the manual.
- You can download the complete manual from: [www.heydownloads.com](http://www.heydownloads.com) by clicking the link below



- Please note: If there is no response to **CLICKING** the link, please download this PDF first and then click on it.

CLICK HERE TO **DOWNLOAD** THE COMPLETE MANUAL