

773



Bobcat®

Service Manual

**(773 S/N 509635001 & Above)
(773 Europe Only S/N 509616001–509634999)**

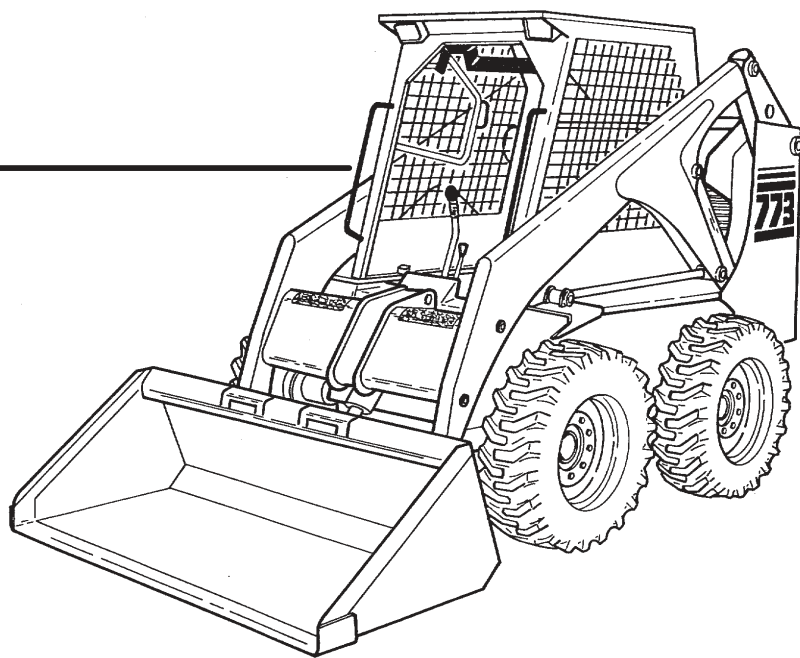

Dealer Copy — Not for Resale

Doosan purchased Bobcat Company from Ingersoll-Rand Company in 2007. Any reference to Ingersoll-Rand Company or use of trademarks, service marks, logos, or other proprietary identifying marks belonging to Ingersoll-Rand Company in this manual is historical or nominative in nature, and is not meant to suggest a current affiliation between Ingersoll-Rand Company and Bobcat Company or the products of either.

**EQUIPPED WITH
BOBCAT INTERLOCK
CONTROL SYSTEM (BICS™)**

6900092 (6–12)
1 of 556



Printed in U.S.A.

© Bobcat Company 1997

CLICK HERE TO **DOWNLOAD** THE COMPLETE MANUAL

- Thank you very much for reading the preview of the manual.
- You can download the complete manual from: www.heydownloads.com by clicking the link below



- Please note: If there is no response to **CLICKING** the link, please download this PDF first and then click on it.

CLICK HERE TO **DOWNLOAD** THE COMPLETE MANUAL

SAFETY INSTRUCTIONS

WARNING

Instructions are necessary before operating or servicing machine. Read and understand the Operation & Maintenance Manual, Handbook and signs (decals) on machine. Follow warnings and instructions in the manuals when making repairs, adjustments or servicing. Check for correct function after adjustments, repairs or service. Untrained operators and failure to follow instructions can cause injury or death.

W-2003-0199

The following publications provide information on the safe use and maintenance of the loader and attachments:

- The Delivery Report is used to assure that complete instructions have been given to the new owner and that the machine is in safe operating condition.
- The Operation & Maintenance Manual delivered with the loader gives operating information as well as routine maintenance and service procedures. It is a part of the loader and must stay with the machine when it is sold. Replacement Operation & Maintenance Manuals can be ordered from your Bobcat loader dealer.
- The loader has machine signs (decals) which instruct on the safe operation and care. The signs and their locations are shown in the Operation & Maintenance Manual. Replacement signs are available from your Bobcat loader dealer.
- The loader has a plastic Operator's Handbook fastened to the operator cab. Its brief instructions are convenient to the operator. The Handbook is available from your dealer in an English edition or one of many other languages. See your Bobcat dealer for more information on translated versions.
- The EMI Safety Manual (available in Spanish) delivered with the loader gives general safety information.
- The Service Manual and Parts Manual are available from your dealer for use by mechanics to do shop-type service and repair work.
- The Skid-Steer Loader Operator Training Course is available through your local dealer. This course is intended to provide rules and practices for correct operation of the Bobcat loader. The course is available in English and Spanish version.
- The Service Safety Training Course is available from your Bobcat dealer. This course provides information for safe and correct service procedures for Bobcat Skid-Steer loaders.
- The Bobcat Skid-Steer Loader Safety Video is available from your Bobcat Dealer.

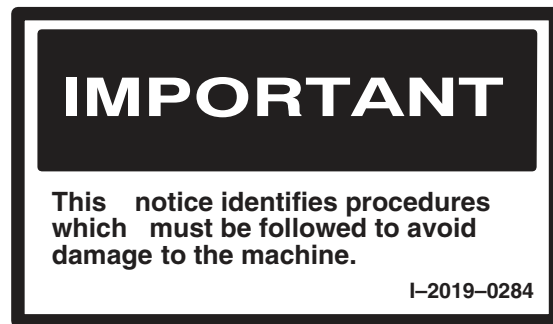

Safety Alert Symbol: This symbol with a warning statement, means: "Warning, be alert! Your safety is involved!" Carefully read the message that follows.

LIFT ARM SUPPORT DEVICE

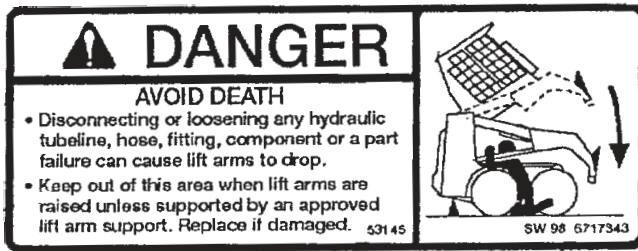

Installing Lift Arm Support Device

Put jackstands under the rear corners of the loader.

Remove the lift arm support device (Item 1) [A] from storage position.

The operator must be in the operator's seat, with the seat belt fastened and seat bar lowered, until the lift arm support device is installed.

Start the engine, and raise the lift arms all the way up. Have a second person install the lift arm support device (Item 1) [B] over the rod of one of the lift cylinders.

The lift arm support device must be tight against the cylinder rod. The tabs of the lift arm support device must be under the cylinder as shown (Item 2) [B].

Lower the lift arms slowly until the stop is held between the lift arms and lift cylinder [C].

Removing Lift Arm Support Device

The operator must be in the operator's seat, with the seat belt fastened and seat bar lowered, until the lift arm support device is removed and the lift arms are lowered all the way.

Start the engine, raise the lift arms all the way up.

Have a second person remove the lift arm support device.

Return the lift arm support device to storage position and secure with clamping knobs.

Remove the jackstands.

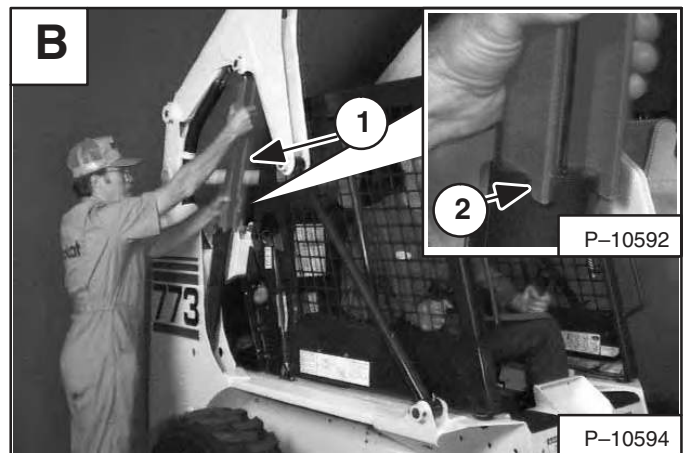
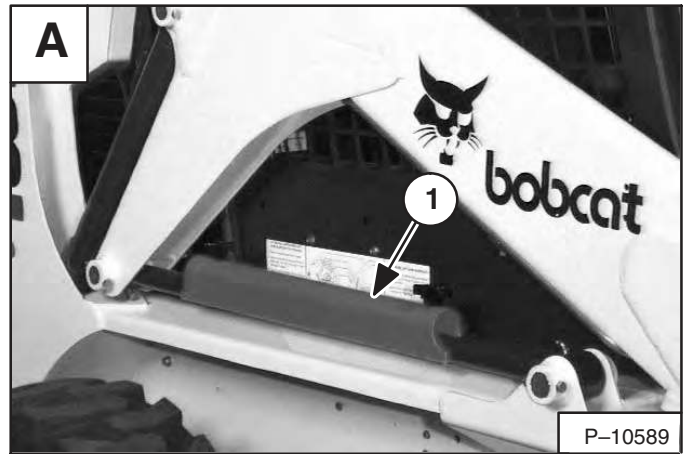

FUEL SYSTEM (Cont'd)

Removing Air From The Fuel System

After replacing the fuel filter element or when the fuel tank has run out of fuel, the air must be removed from the fuel system before starting the engine.



WARNING

Diesel fuel or hydraulic fluid under pressure can penetrate skin or eyes, causing serious injury or death. Fluid leaks under pressure may not be visible. Use a piece of cardboard or wood to find leaks. Do not use your bare hand. Wear safety goggles. If fluid enters skin or eyes, get immediate medical attention from a physician familiar with this injury.

W-2072-0496

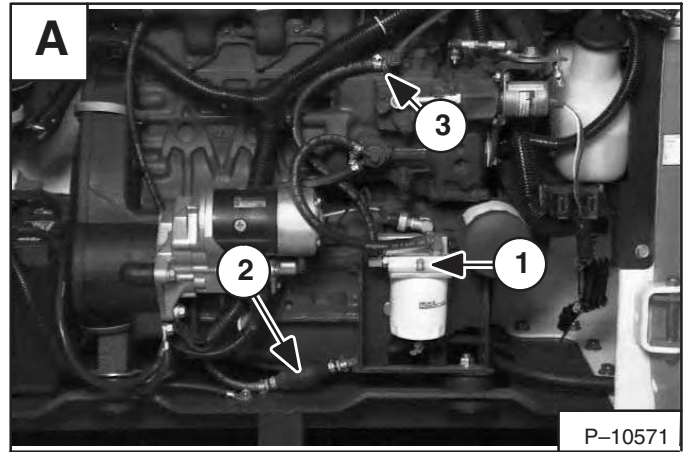

Open the vent (Item 1) [A] on the fuel filter housing.

Operate the hand pump (priming bulb) (Item 2) [A] until fuel flows from the vent with no air bubbles.

Close the vent (Item 1) [A] on the fuel filter housing.

Open the vent (Item 3) [A] on the fuel injection pump.

Operate the hand pump (priming bulb) (Item 2) [A] until the pump feels solid.

Tighten the vent plug (Item 3) [A].

Start the engine.

It may be necessary to open the vent plug (Item 3) [A] briefly until the engine runs smoothly.

TIRE MAINTENANCE

Wheel Nuts

See the *SERVICE SCHEDULE* Page 1–3 for the service interval to check the wheel nuts. The correct torque is 105–115 ft.-lbs. (142–156 Nm) torque [A].

Tire Rotation

Check the tires regularly for wear damage and pressure. (See *SPECIFICATIONS* Page 9–1 for the correct tire pressure.)

Rear tires usually wear faster than front tires. To keep tire wear even, move the front tires to the rear and rear tires to the front [B].

It is important to keep the same size tires on each side of the loader. If different sizes are used, each tire will be turning at a different speed and cause excessive wear. The tread bars of all the tires must face the same direction.

Recommended tire pressure must be maintained to avoid excessive tire wear and loss of stability and handling capability. Check for the correct pressure before operating the loader.

Tire Mounting

Tires are to be repaired only by an authorized person using the proper procedures and safety equipment. Tires and rims must always be checked for correct size before mounting. Check rim and tire bead for damage.

The rim flange must be cleaned and free of rust. The tire bead and rim flange must be lubricated with a rubber lubricant before mounting the tire, avoid excessive pressure which can rupture the tire and cause serious injury or death. During inflation of the tire, check the tire pressure frequently to avoid over inflation.

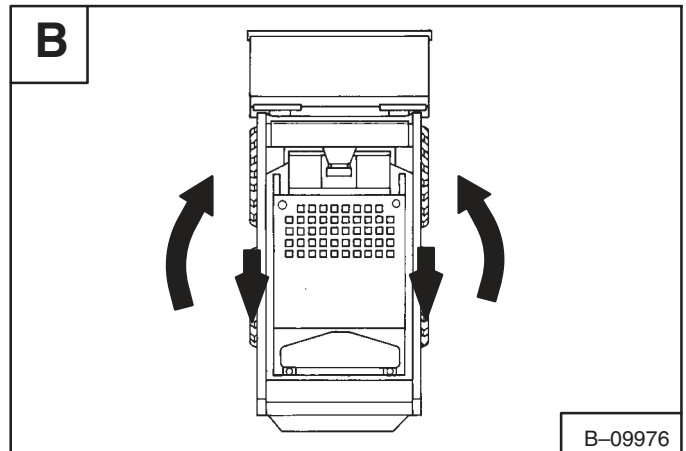

WARNING

Do not inflate tires above specified pressure. Failure to use correct tire mounting procedure can cause an explosion which can result in injury or death.

W-2078-1285

IMPORTANT

Inflate tires to the **MAXIMUM** pressure shown on the sidewall of the tire. **DO NOT** mix brands of tires used on the same loader.

I-2057-0794

REMOTE START SWITCH

Procedure

The tool listed will be needed to do the following procedure:

MEL1429 – Remote Start Switch

WARNING

Put jackstands under the front axles and rear corners of the frame before running the engine for service. Failure to use jackstands can allow the machine to fall or move and cause injury or death.

W-2017-0286

The Remote Start Switch (Item 1 [A]) is required when the operator cab is in the raised position for service and the service technician needs to start the engine. The operator cab wire harness connectors must be separated from the engine wiring harness connector under the cab.

The remote start switch is required when the service technician is adjusting the steering linkage and checking the hydraulic/hydrostatic system.

Lift and block the loader. (See Page 1-4.)

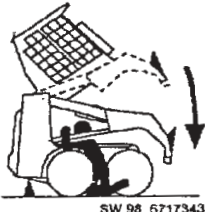
 DANGER	
AVOID DEATH	
<ul style="list-style-type: none">• Disconnecting or loosening any hydraulic tubeline, hose, fitting, component or a part failure can cause lift arms to drop.• Keep out of this area when lift arms are raised unless supported by an approved lift arm support. Replace if damaged. 53145	SW 98 6717343

Raise the lift arms and install an approved lift arm support device. (See Page 1-7.)

WARNING

Never work on a machine with the lift arms up unless the lift arms are secured by an approved lift arm support device. Failure to use an approved lift arm support device can allow the lift arms or attachment to fall and cause injury or death.

W-2059-0598

Raise the operator cab. (See Page 1-9.)

Connect the remote start switch to these connectors (Item 1) [B].

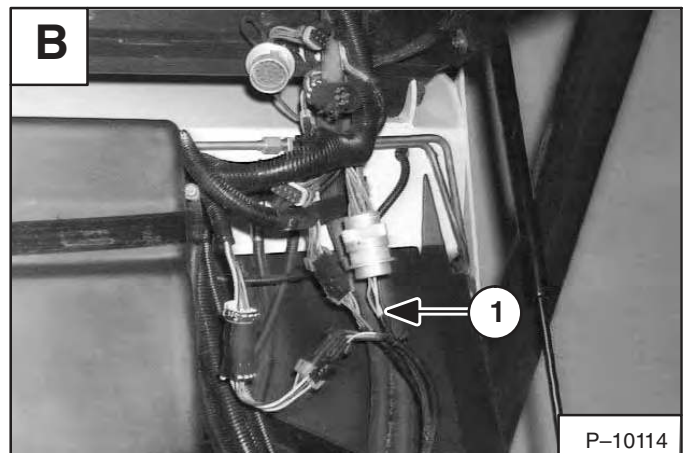
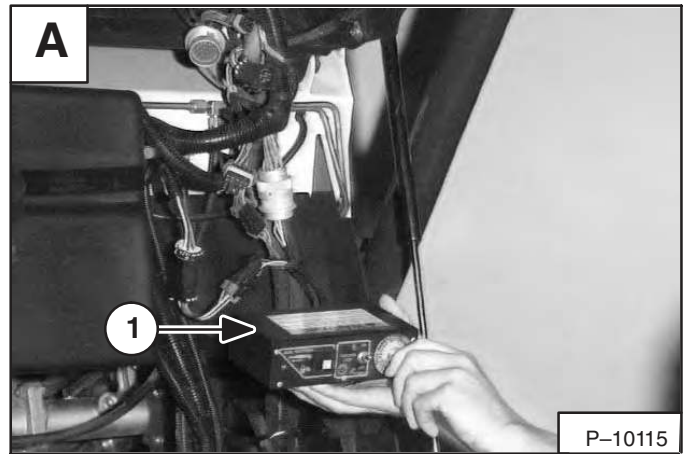

LIFT CYLINDER(S)

Checking The Lift Cylinder(s) For Internal Leakage

Lower the lift arms. Stop the engine. Pull up on the lift arm bypass control and move the lift pedal to release the hydraulic pressure. Raise the seat bar.

NOTE: Fuses may need to be moved for clearance.

Check only one cylinder at a time. Disconnect the tubeline (Item 1) [A] from the lift cylinder rod end port.

Lift the tubeline up for clearance. Disconnect the hose (Item 1) [B] from the lift cylinder base end port (Item 2) [B].

Install a plug in the hose (Item 1) [B] and tighten.

Reconnect the tubeline (Item 2) [A] to the lift cylinder rod end port. Engage the parking brake. Lower the seat bar. Start the engine and push the top (toe) of the lift pedal.

If there is any leakage from the base end cylinder port (Item 2) [B], remove the lift cylinder for repair. Repeat the procedure to check the other lift cylinder.

Removal And Installation

Stop the engine. Pull up on the lift arm by-pass control and move the lift pedal to release the hydraulic pressure. Raise the operator cab. (See Page 1-1.)

Disconnect the two hoses (Item 1) [B] from the lift cylinder.

Remove the retainer bolt (Item 2) [A] & [C] and nut from the pivot pin.

Installation: Tighten the retainer bolt and nut to 18–20 ft.-lbs. (24–27 Nm) torque.

Remove the pivot pin (Item 3) [A] & (Item 1) [C] from the cylinder.

Slide the lift cylinder forward and remove it from the loader.

Reverse the removal procedure to install the lift cylinder.

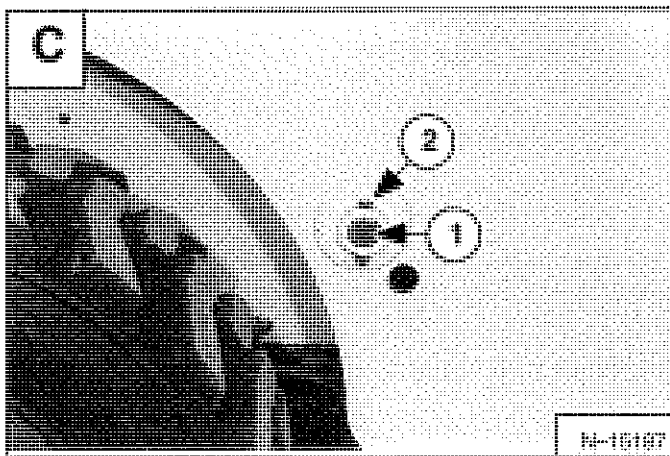
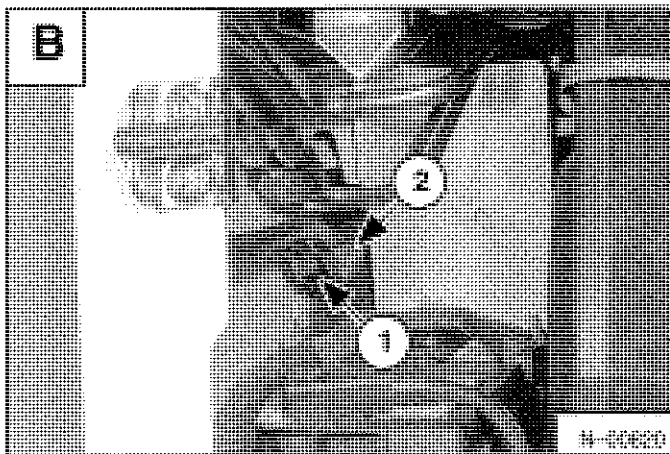
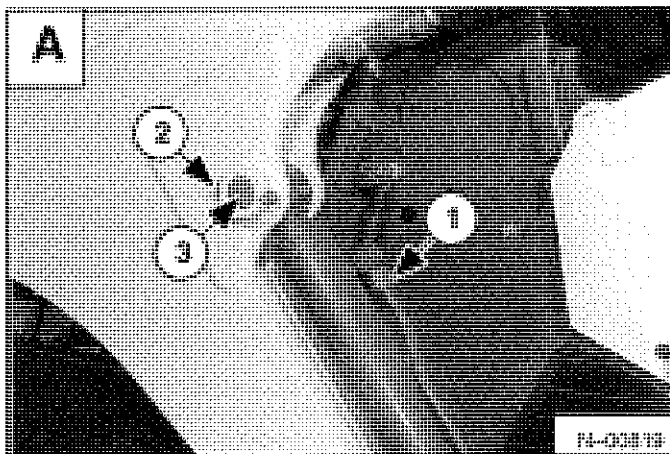

⚠ WARNING

Always clean up spilled fuel or oil. Keep heat, flames, sparks or lighted tobacco away from fuel and oil. Failure to use care around combustibles can cause explosion or fire which can result in injury or death.

W-2103-1285

⚠ WARNING

Diesel fuel or hydraulic fluid under pressure can penetrate skin or eyes, causing serious injury or death. Fluid leaks under pressure may not be visible. Use a piece of cardboard or wood to find leaks. Do not use your bare hand. Wear safety goggles. If fluid enters skin or eyes, get immediate medical attention from a physician familiar with this injury.

W-2072-0496

HYDRAULIC CYLINDERS (Cont'd)

Assembly (Cont'd)

If a seal was removed from the head use the following procedure to install a new one.

NOTE: Do not overstretch the seal.

Install the seal on the tool and stretch it until it fits the piston **[A]**.

Allow the O-ring to stretch for 30 seconds before removing it from the tool.

NOTE: Do not turn (roll) the seal as you install it. Damage to the seal may result.

Use a ring compressor to compress the seal to the correct size **[B]**. Leave the tool over the seal for five minutes.

Install the head on the rod **[C]**.

Install the piston on the rod **[D]**.

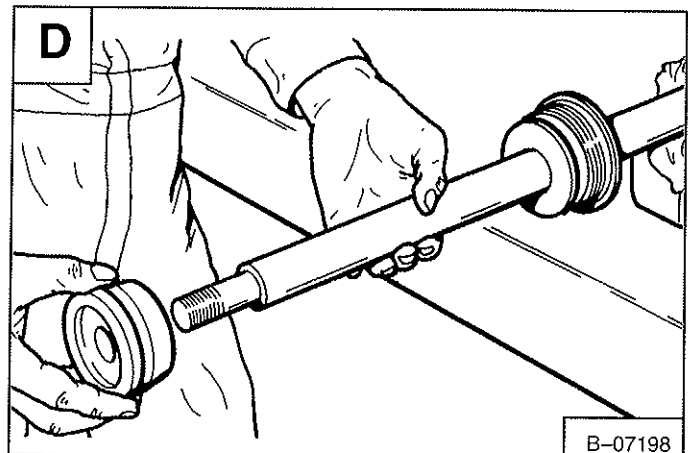
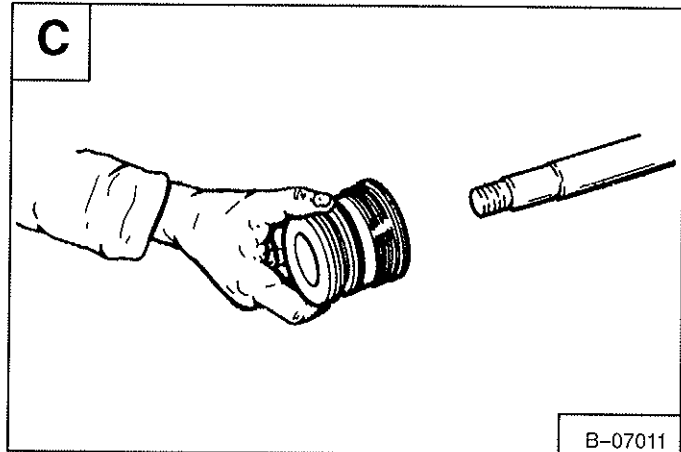
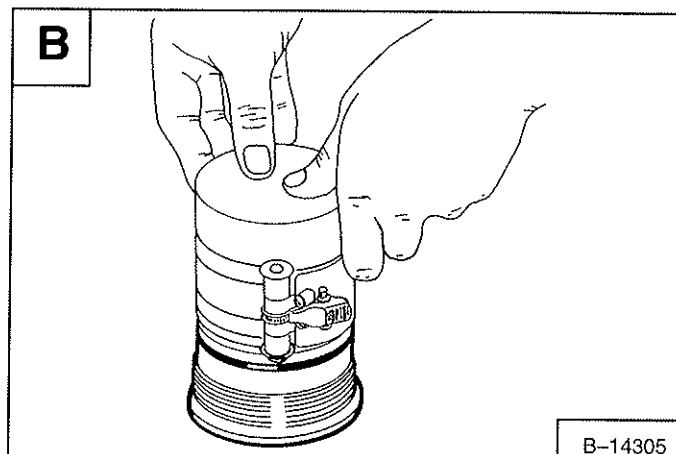
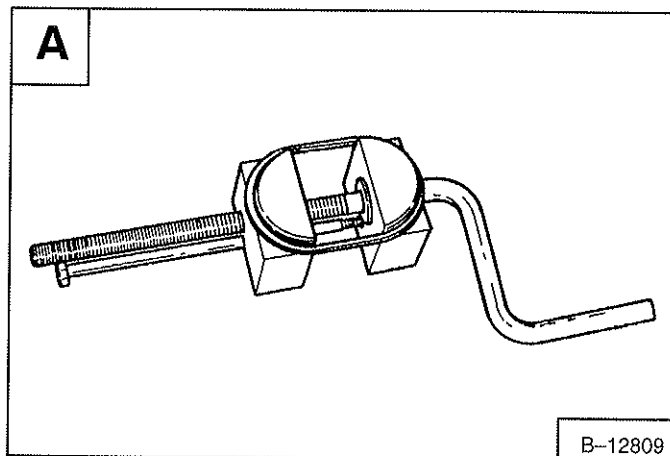

BICS™ VALVE (S/N 509640660 & Above, S/N 509616542 & Above) (Cont'd)

Installation

Install the four large O-rings (Item 1) [A] and the small O-ring (Item 2) [A] on the top of the control valve.

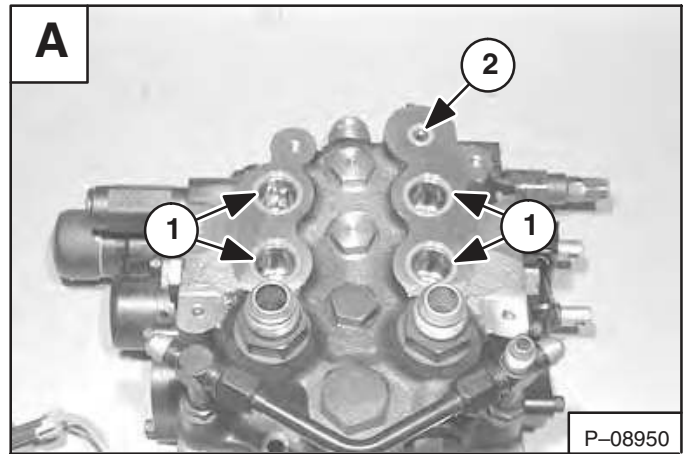

Install the BICS™ valve on the control valve [B].



Install the six mounting bolts [C].

The chart below lists the correct torque specifications and tightening sequence when reinstalling the BICS™ valve assembly to the control valve. Thoroughly clean and dry bolts and threads in valve. Use liquid adhesive LOCTITE #242 or equivalent.

Step	Torque	Sequence
1	110–130 in.-lbs. (12,4–14,7 Nm)	1, 2, 3, 4, 5 & 6
2	190–210 in.-lbs. (21,5–23,7 Nm)	
3*	190–210 in.-lbs. (21,5–23,7 Nm)	

*Torque must be 190–210 in.-lbs. (21,5–23,7 Nm) for every bolt or repeat step 3.

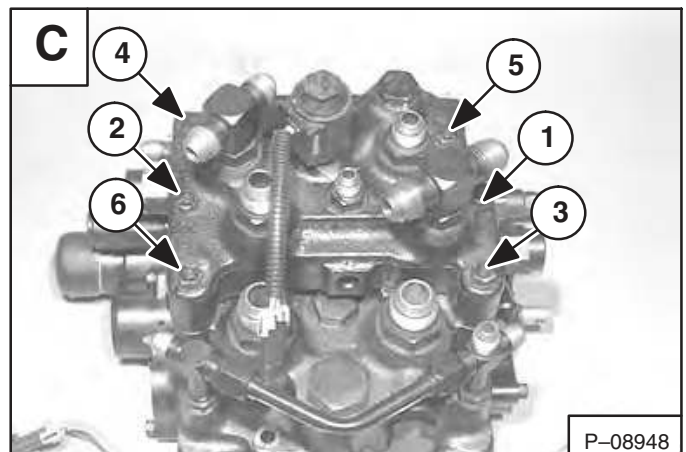

CONTROL VALVE (S/N 509640660 & Above, S/N 509616542 & Above) (Cont'd)

Lift Spool And Detent

Disassembly

Remove the snap ring (Item 1) [A] and washer (Item 2) [A].

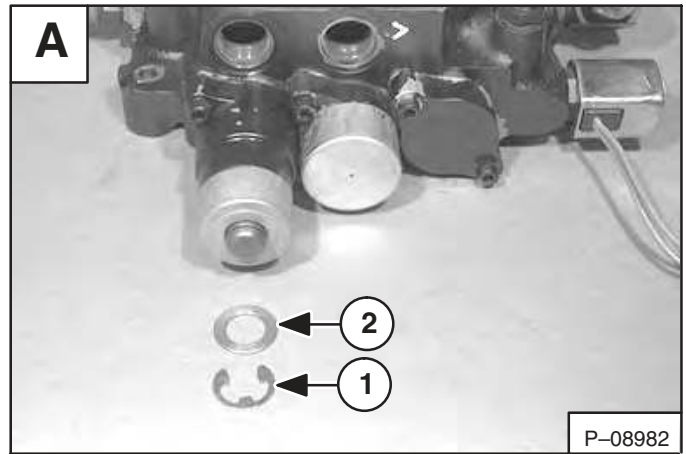

Remove the two bolts (Item 1) [B] from the detent bonnet.
Remove the bonnet.

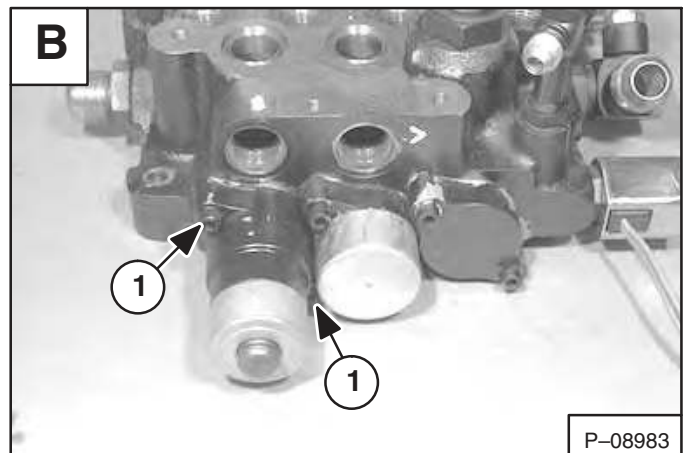

IMPORTANT

The detent assembly has small springs and balls. Do not lose these parts during disassembly and assembly.

I-2012-0284

Wrap a shop towel around the detent assembly. This will prevent the detent balls and spring from being lost when the detent sleeve is removed [C].



Remove the detent sleeve (Item 1) [D], detent balls (Item 2) [D] and spring (Item 3) [D].

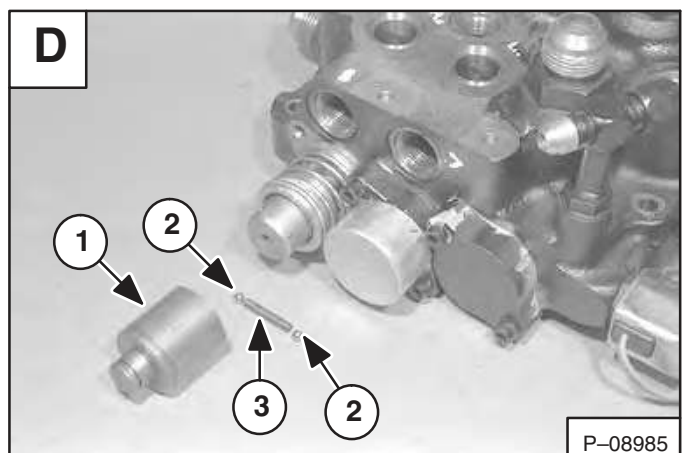

CONTROL VALVE (S/N 509640660 & Above, S/N 509616542 & Above) (Cont'd)

Auxiliary Spool (Cont'd)

Assembly (Cont'd)

Install the auxiliary spool covers (Item 1) [A] & [B].

Install the two bolts (Item 2) [A] & [B].

Tighten the bolts to 90–100 in.-lbs. (10,2–1 1,3 Nm) torque.

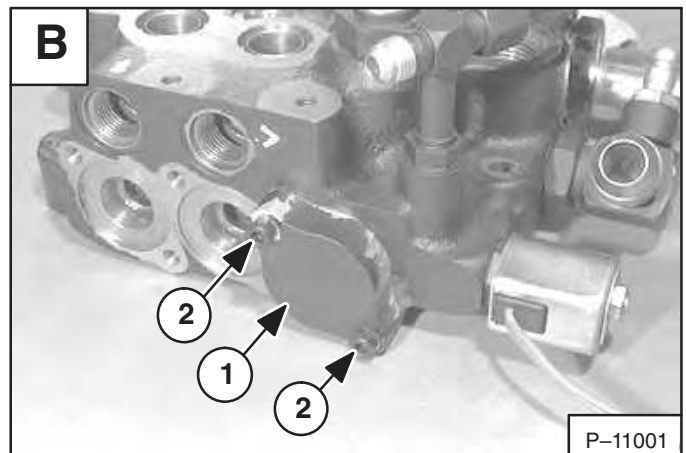
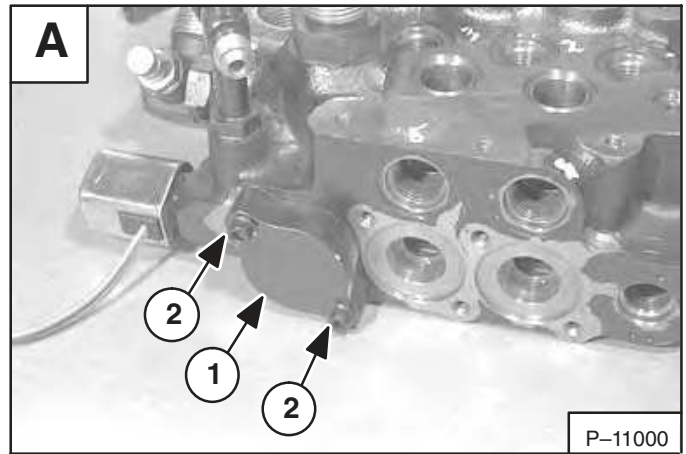

Tilt Spool And Centering Spring

Assembly

Slide a new spool seal (Item 1) [C] on the spool.

NOTE: The spool seal must be installed with the lip face toward the valve body. The lip face has the largest outside diameter.

Install the bushing (Item 2) [C], washer (Item 3) [C], spring (Item 4) [C], collar (Item 5) [C], and adapter (Item 6) [C].

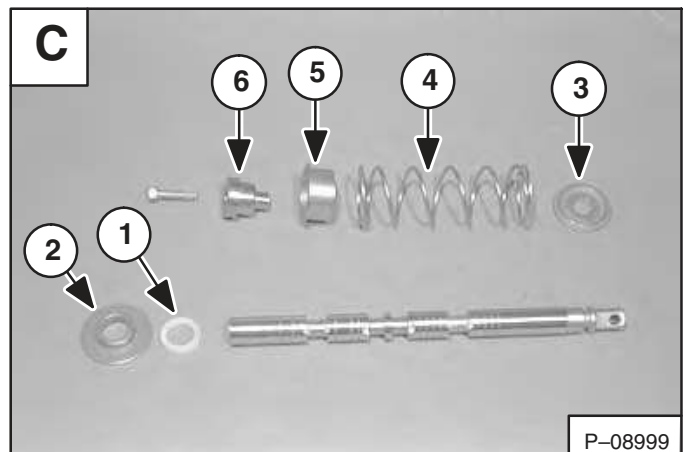

Clamp the activating end of the tilt spool in a vise.

Install the centering spring bolt (Item 1) [D].

Tighten the bolt to 90–100 in.-lbs. (10,2–1,3 Nm) torque.

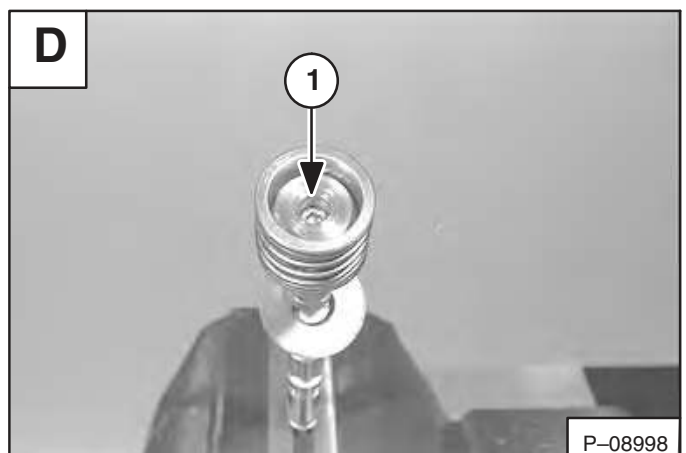

CONTROL VALVE (S/N 509640659 & Below , S/N 509616541 & Below)

Removal And Installation

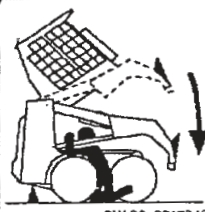
 <h2 style="margin: 0;">DANGER</h2> <p style="margin: 0;">AVOID DEATH</p> <ul style="list-style-type: none"> • Disconnecting or loosening any hydraulic tubeline, hose, fitting, component or a part failure can cause lift arms to drop. • Keep out of this area when lift arms are raised unless supported by an approved lift arm support. Replace if damaged. <p style="font-size: small; margin: 0;">531 45</p>	 <p style="font-size: x-small; margin: 0;">SW 98 6717343</p>
--	---

Raise the lift arms and install an approved lift arm support device. (See Page 1-1.)

 <h2 style="margin: 0;">WARNING</h2> <p style="margin: 0;">Never work on a machine with the lift arms up unless the lift arms are secured by an approved lift arm support device. Failure to use an approved lift arm support device can allow the lift arms or attachment to fall and cause injury or death.</p> <p style="font-size: x-small; margin: 0;">W-2059-0598</p>

Stop the engine. Move the hydraulic controls to release the hydraulic pressure. Raise the seat bar.

Raise the operator cab. (See Page 1-1.)

Control panel removal is optional. (See Page 3-1.)

<h2 style="margin: 0;">IMPORTANT</h2> <p style="margin: 0;">When repairing hydrostatic and hydraulic systems, clean the work area before disassembly and keep all parts clean. Always use caps and plugs on hoses, tubelines and ports to keep dirt out. Dirt can quickly damage the system.</p> <p style="font-size: x-small; margin: 0;">I-2003-0888</p>

Thoroughly clean the control valve area.

Loosen or remove the tubeline clamp (Item 1) [A].

Disconnect the drain hoses (Item 1) [B] from the main control valve.

Disconnect the electric solenoid connectors (Item 2)[B].

Disconnect the outlet tubeline (Item 1) [C] from the control valve.

Disconnect both tubelines (Item 1) [D] from the auxiliary section of the control valve.

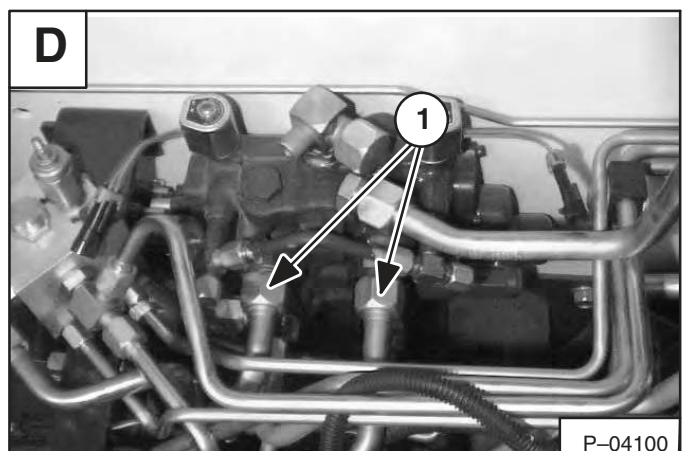
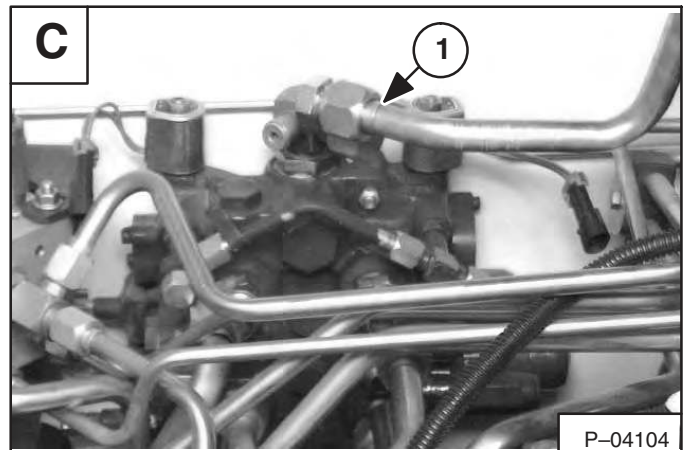
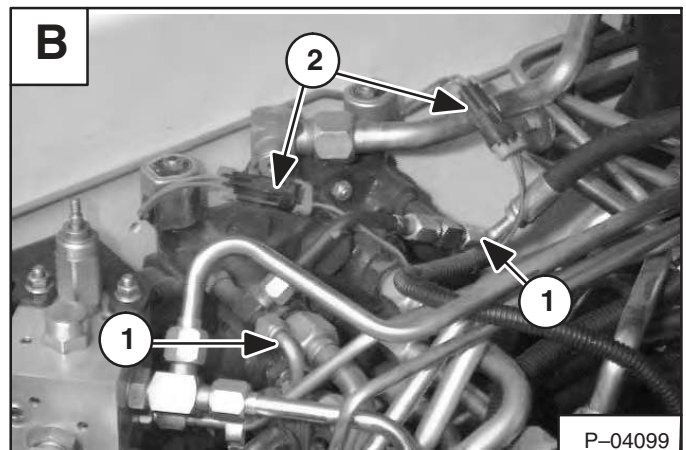
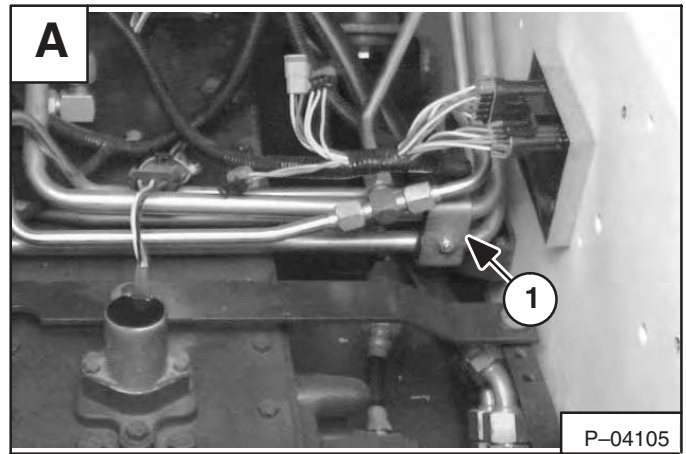

CONTROL VALVE (S/N 509640659 & Below , S/N 509616541 & Below) (Cont'd)

Lift Spool Detent (Cont'd)

Remove the spool, centering spring, back-up washer and spool seal assembly from the control valve [A].



Put the linkage end of the spool in a vise.

NOTE: BE CAREFUL when removing the detent adapter, because there is spring pressure.

Loosen the detent adapter [B].



Remove the detent adapter, end cap and centering spring [C].

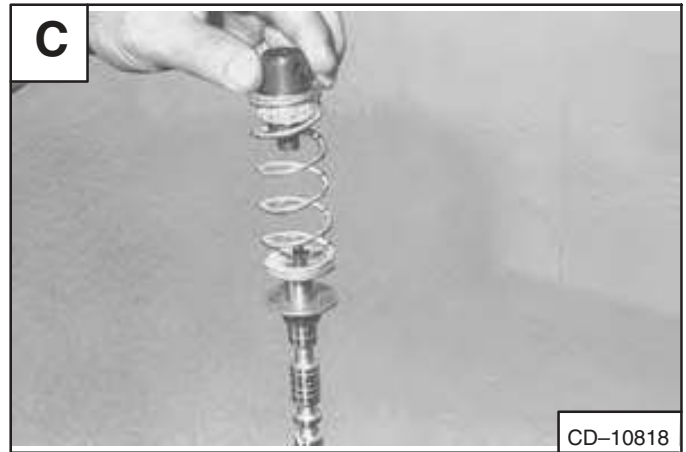

Remove the back-up washer and spool seal [D].



HYDRAULIC PUMP (Cont'd)

Removal And Installation (Cont'd)

Remove the two mounting bolts (Item 1) [A] from the hydraulic pump with a 5/16 inch allen wrench.

NOTE: The allen wrench will need to be modified for the procedure.

Installation: Tighten the mounting bolts to 27–37n.-lbs. (37–50 Nm) torque.

Remove the hydraulic pump from the hydrostatic pump.

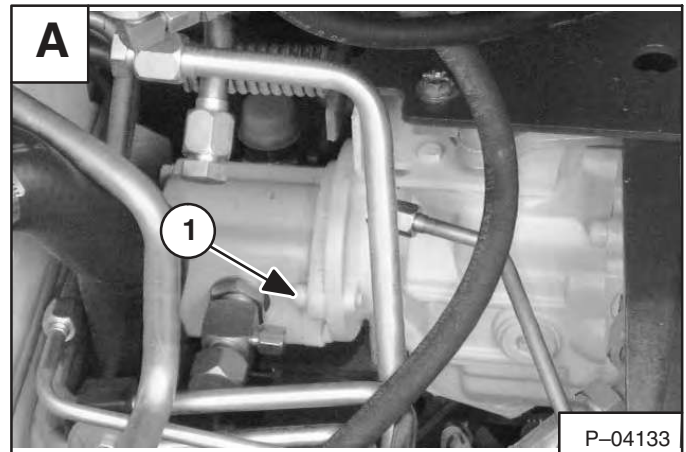

Remove the coupler (Item 1)[B] from the hydraulic pump shaft.

Remove the large O-ring (Item 2) [B].

Installation: Use a new O-ring when installing the hydraulic pump.

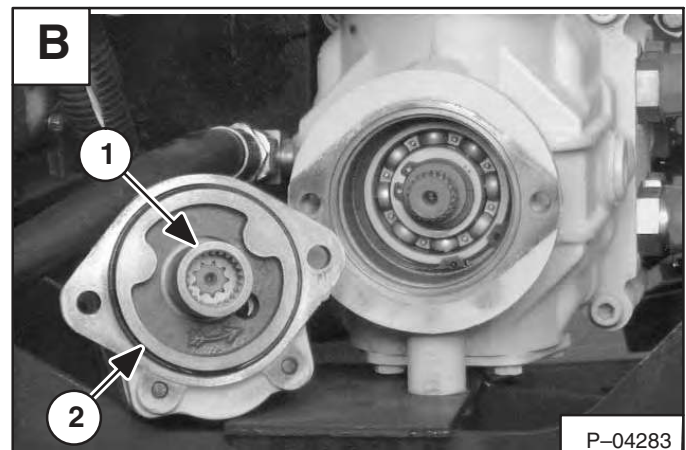

WARNING

Always clean up spilled fuel or oil. Keep heat, flames, sparks or lighted tobacco away from fuel and oil. Failure to use care around combustibles can cause explosion or fire which can result in injury or death.

W-2103-1285

See Page 2-80 for the proper
Assembly procedures.

Disassembly and

CONTROL INTERLOCK LINKAGE (Pedal or Mechanical Hand) (Cont'd)

Adjustment

WARNING

AVOID INJURY OR DEATH

Adjust locking tabs on control linkage so that lift and tilt control pedals or (Mechanical Hand controls) are locked in neutral when the seat bar is up.

W-2104-0199

Check the interlock linkages (Item 1) [A] so they are free and lock both controls (pedal or mechanical hand) when in neutral, (shown with interlock shield removed).

Check to ensure the locking tab (Item 2) [A] is centered in the slot (Item 1) [A].

If not, loosen the tab mounting nuts (Item 3) [A] and bolts. Center the tab in the slot.

Installation: Tighten the mounting nuts and bolts to 25 ft.-lbs. (34 Nm) torque.

With the controls in neutral the locking tabs must fit into the slot of the interlocks as shown [B], when adjusted properly.

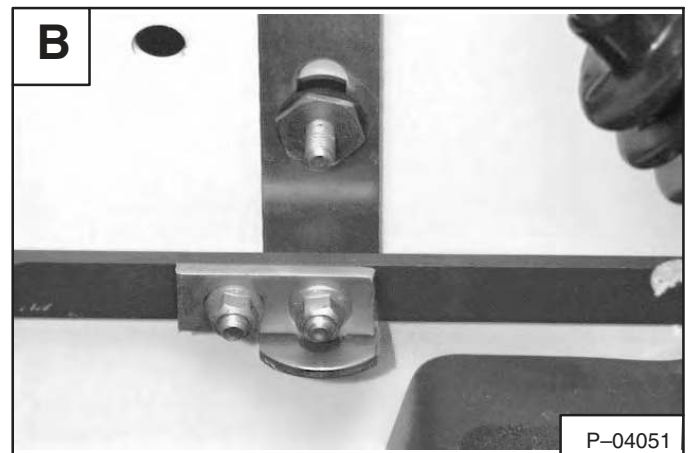
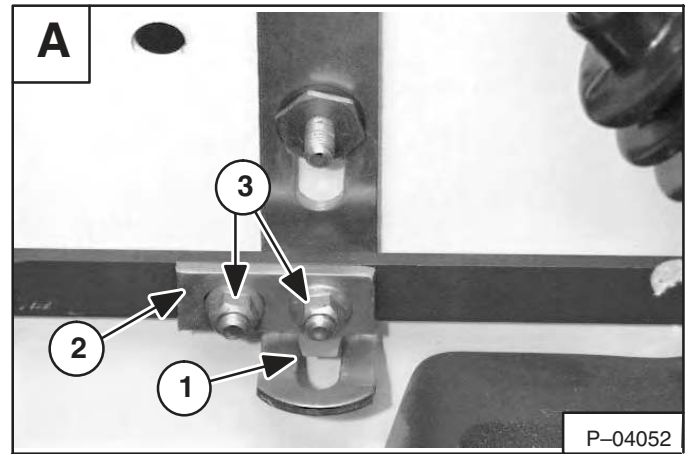

TROUBLESHOOTING

Chart

The following troubleshooting chart is provided for assistance in locating and correcting problems which are most common. Many of the recommended procedures must be done by authorized Bobcat Service Personnel only.



WARNING

Check for correct function after adjustments, repairs or service. Failure to make correct repairs or adjustments can cause injury or death.

W-2004-1285

PROBLEM	CAUSE
No drive on one side, in one direction.	1, 2
No drive on one side in both directions.	2, 3, 4, 5
The loader does not move in a straight line.	2, 3, 5, 6, 7
The hydrostatic system is overheating.	8, 9, 10, 11
Service code HP 2 appears. (Warnings, low charge pressure.)	8, 11, 12, 13

KEY TO CORRECT THE CAUSE

1. The hydrostatic pump replenishing valves not seating.
2. The steering linkage needs adjustment.
3. The hydrostatic pump has damage.
4. The final drive chains are broken.
5. The hydrostatic motor has damage.
6. The tires do not have the correct tire pressure.
7. The tires are not the same size.
8. The hydrostatic fluid is not at the correct level.
9. The oil cooler has a restriction.
10. The temperature sending switch is not operating correctly.
11. The loader is not being operated at the correct RPM.
12. The hydraulic charge pressure sender is defective.
13. Pump is defective or worn hydrostatics.

STEERING LINKAGE (Cont'd)

Steering Neutral Adjustment (Cont'd)

Adjust the right hand centering block **[A]**.

Move the right hand steering lever until the tires do not turn (neutral position).

Move the right hand centering block to the left until it contacts both pintle cams and the steering lever is still in the neutral position **[A]**.

Tighten the bolts to 25–28 ft.-lbs. (34–38 Nm) torque.

Test both levers by moving them backward and forward and letting them return to neutral by the return spring force.

If the levers do not return to neutral and the tires do not come to a complete stop, repeat the adjustment procedure again.

Stop the engine.

Tighten the two bolts (Item 1)**[B]** to 11–13 ft.-lbs. (15–17 Nm) torque, then tighten the two nuts (Item 2) **[B]** to 21–25 ft.-lbs. (28–33 Nm) torque.

Tighten the two bolts to 11–13 ft.-lbs. (15–17 Nm) torque, then tighten the two nuts to 21–25 ft.-lbs. (28–33 Nm) torque at the steering cross shaft (Items 1 & 2) **[C]**.

Remove the service shield. Install the fan drive belt.

Install both access covers.

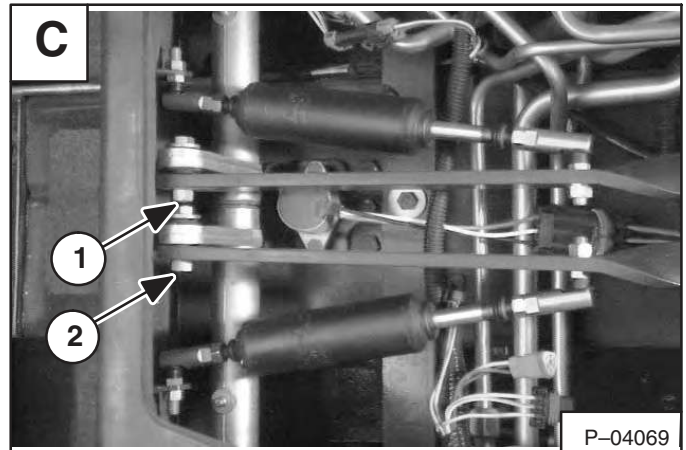
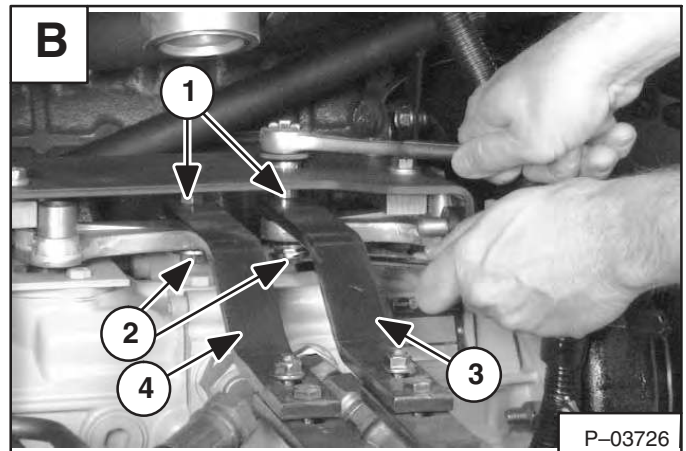
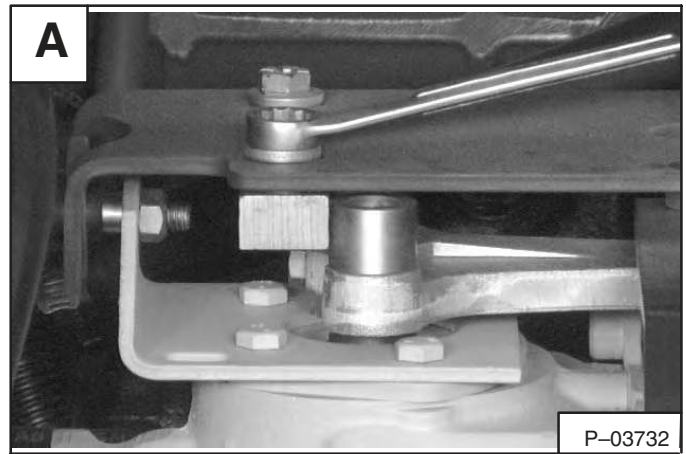

HYDROSTATIC MOTOR 30 SERIES

Parts Identification – (S/N 509639899 & Above & S/N 509616505 & Above)

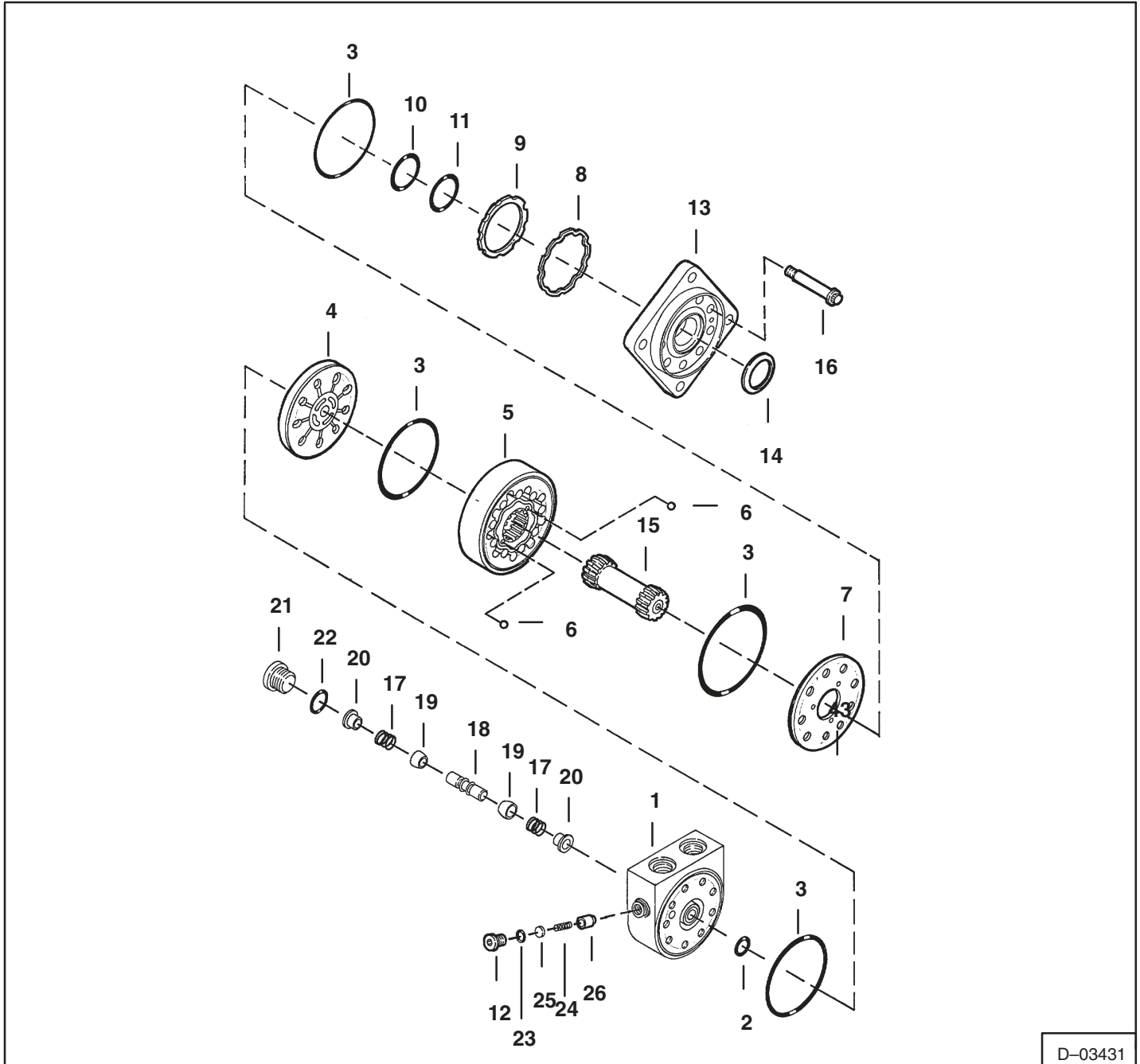

D-03431

Ref.	Description	Ref.	Description
1.	HOUSING	15.	SHAFT, drive
2.	O-RING	16.	BOLT
3.	SEAL, square	17.	SPRING
4.	VALVE, plate	18.	PISTON
5.	GEROLER	19.	POPPET
6.	BALL	20.	SLEEVE
7.	PLATE, balance	21.	PLUG
8.	RING, back-up	22.	O-RING
9.	SEAL	23.	O-RING
10.	RING, back-up	24.	SPRING
11.	O-RING	25.	SHIM
12.	PLUG	26.	POPPET
13.	FLANGE, mounting		
14.	SEAL, face		

HYDROSTATIC MOTOR 30 SERIES (Cont'd)

Assembly (S/N 509639899 & Above & S/N 509616505 & Above) (Cont'd)

Install the seal (Item 1) [A] (as shown).

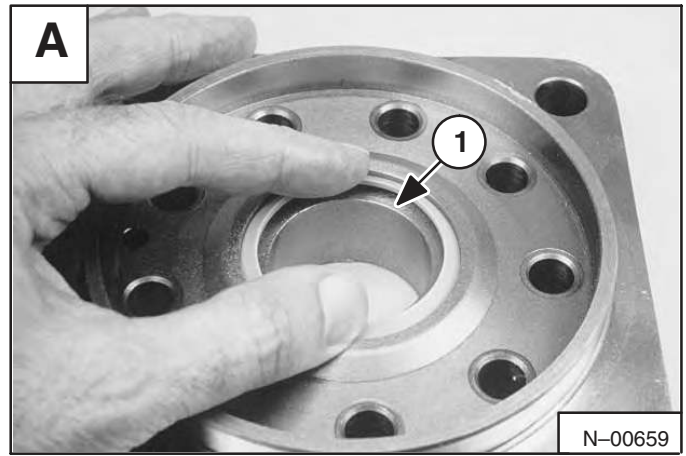

Install the square cut seal (Item 1) [B], seal (Item 2) [B], back-up seal (Item 3) [B], seal (Item 4) [B] and back-up ring (Item 5) [B] in the mounting flange.

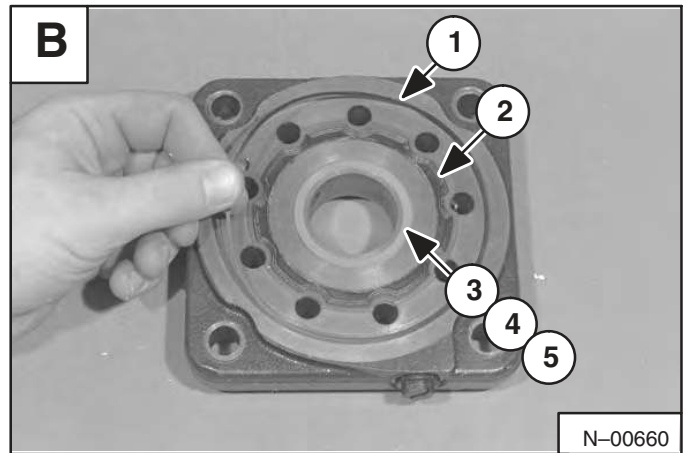

Mark the case drain holes on the side of the balancing plate [C].

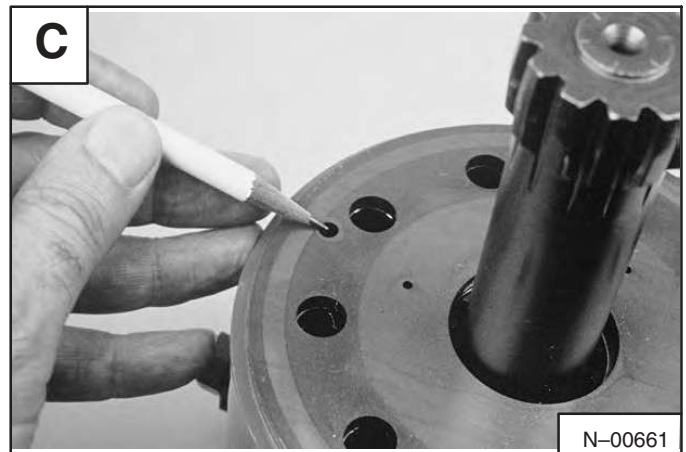

Align the case drain port (Item 1) [D] in the mounting flange with the case drain port in the balancing plate (as shown).

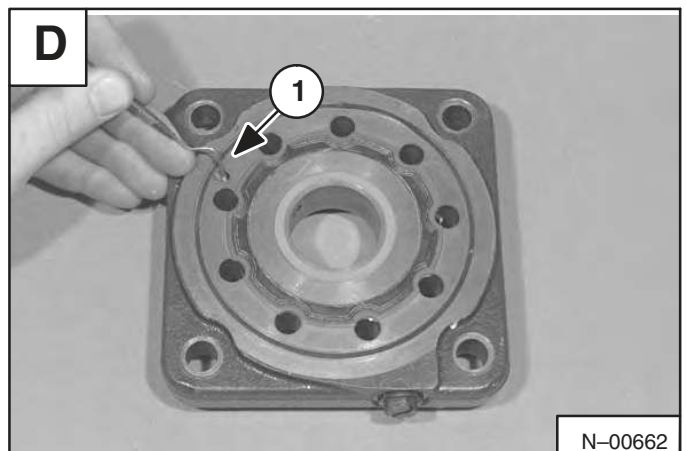

HYDROSTATIC PUMP (Cont'd)

Disassembly And Assembly (Cont'd)

Remove the two small O-rings (Items 1 & 2) [A].

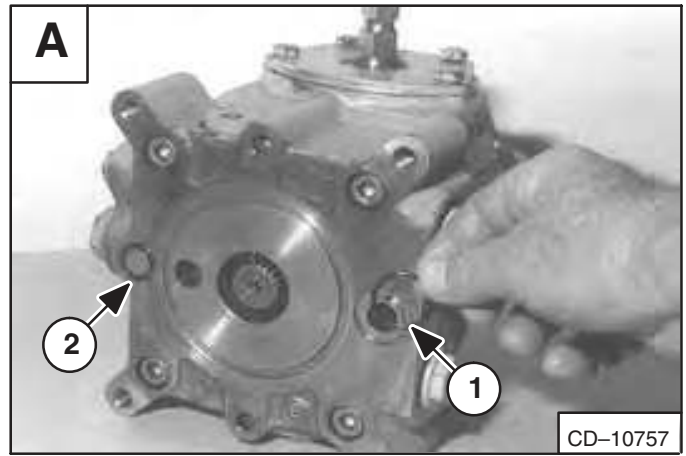

Remove the four bolts from the pump housing end cap [B].

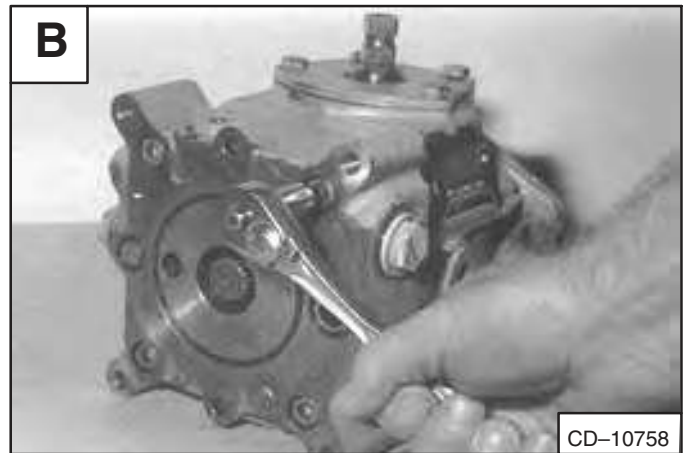

Assemble: Tighten the bolts to 35–45 ft.-lbs. (47–61 Nm) torque [C].



Remove the pump housing end cap. Remove the valve plate from the end cap [D].

Check the brass valve plate on both sides for damage & replace if worn or damaged.

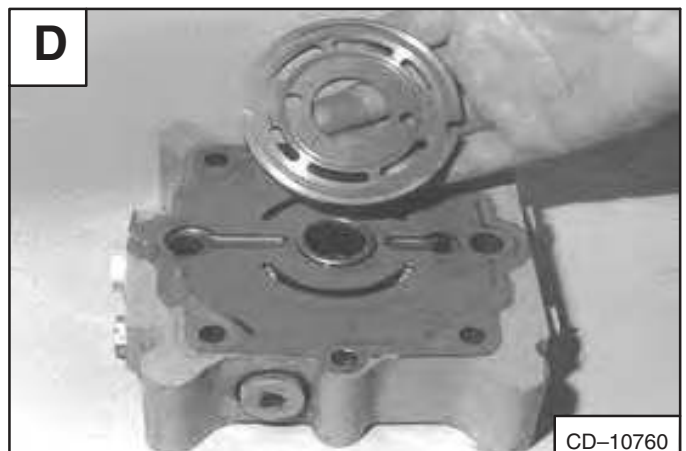

SPRING LOADED DRIVE BELT TENSIONER PULLEY

Removal And Installation

Remove the drive belt shield fastener (Item 1) [A].

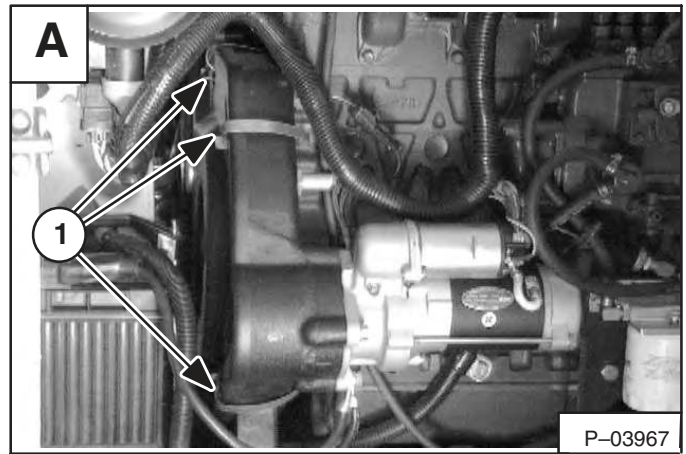

Remove the belt shield [B].

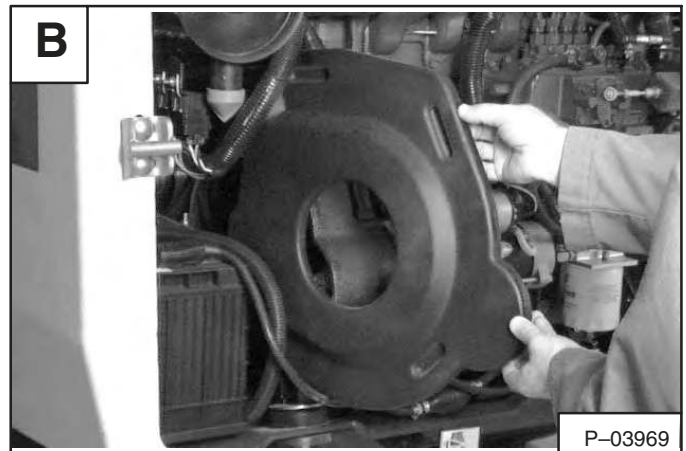

Loosen and remove the tensioner pulley mounting bolt (Item 1) [C].

Installation: Tighten the bolt to 25–28 ft.-lbs. (34–38 Nm) torque.

Remove the belt tensioner pulley from the housing.

Installation: Refer to Page 1–1 in the *PREVENTIVE MAINTENANCE* section to adjust the drive belt correctly

Reverse the removal procedure to install the drive belt tensioner.

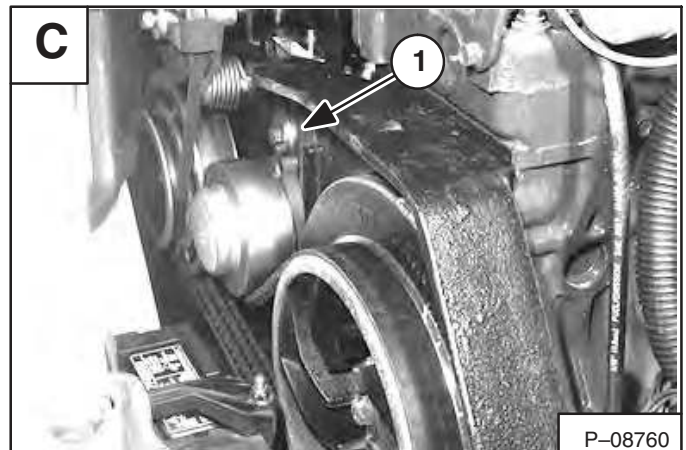

FIXED DRIVE BELT TENSIONER PULLEY (Cont'd)

Assembly (Cont'd)

Put sealant (P/N 6633538) around the diameter of the shaft where the wear sleeve is installed on the shaft [A].

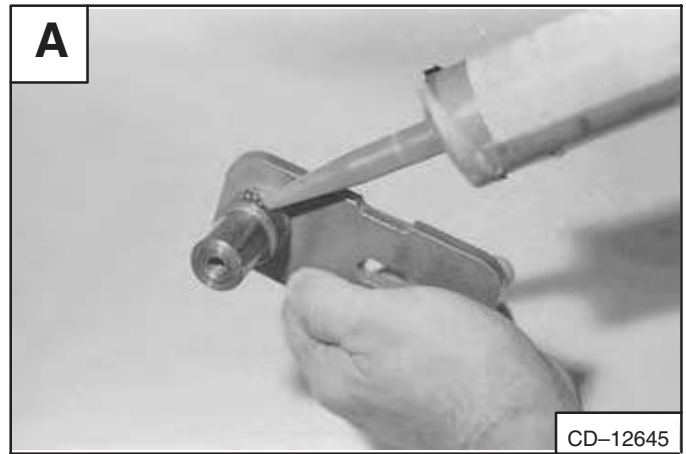

Put grease (P/N 6599719) on the seal lips (Item 1) [B]. Make sure the grease is between the outside and inside lips and all the way around the seal.

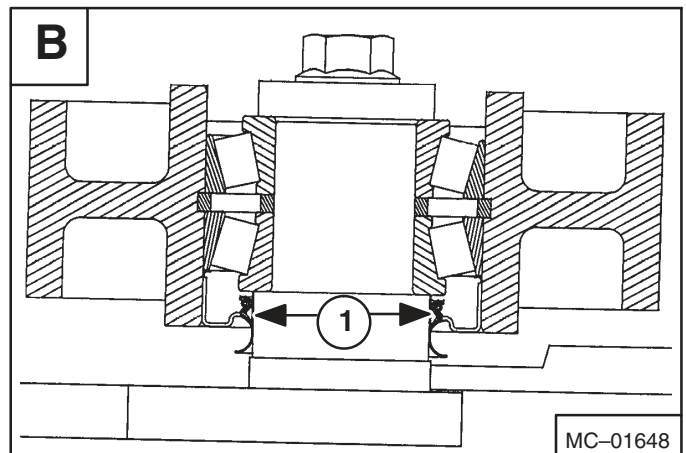

Press the seal into the pulley hub larger diameter using a press [C].

NOTE: The wear sleeve and the seal must be replaced as a unit.

DO NOT damage the seal lips with the sharp edge of the wear sleeve. Install the wear sleeve into the seal.



Use a spacer tube which goes over the shaft and pushes on the inside diameter of the taper bearing, install the pulley, seal and wear sleeve onto the shaft [D].



TRACTION LOCK GUIDES (Cont'd)

Assembly (Cont'd)

Remove the two bolts (Item 1 [A]) and remove the electric solenoid (Item 2) [A] from the center chaincase cover.

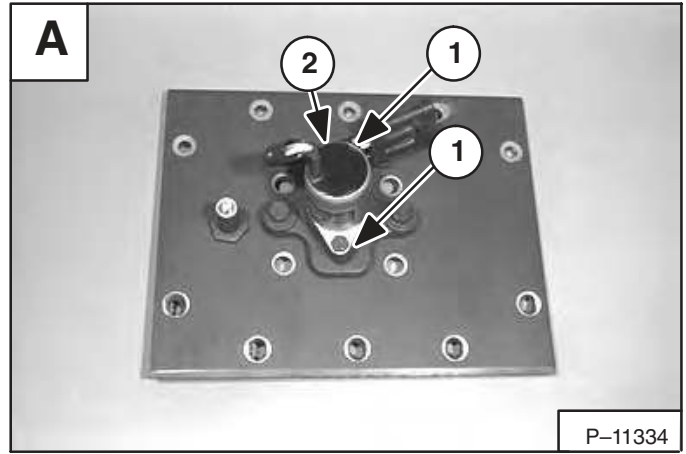

Install the chaincase cover (Item 1) [B] using the ten mounting bolts (Item 2) [B].

Tighten to 25–28 ft.-lbs. (34–38 Nm) torque.

NOTE: Thoroughly clean and dry the bolts and apply LOCTITE #242.

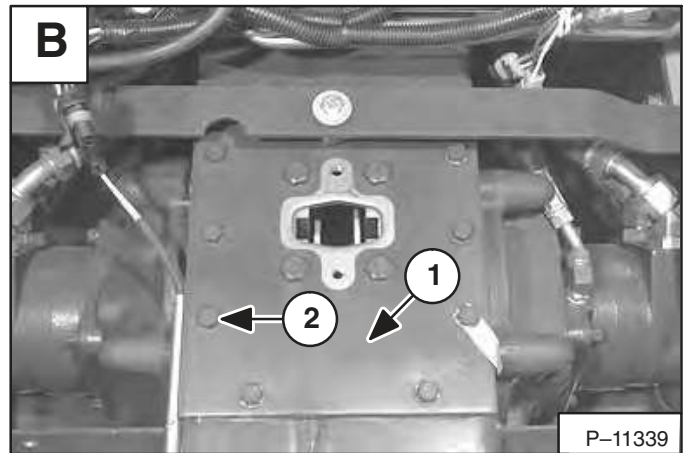

Install the wedge assembly (Item 1) [C] into the grooves in the traction lock guides making sure that there is no binding.

Install the gasket (Item 2) [C].

Install the solenoid mounting bracket assembly (Item 1) [D] on the chaincase cover using the two bolts (Item 2) [D] and tighten to 25–28 ft.-lbs. (34–38 Nm) torque.

NOTE: Be sure the solenoid mounting bracket is installed in the same position. The solenoid mounting surface has a slight angle which tips the top of the solenoid toward the rear of the loader when installed correctly.

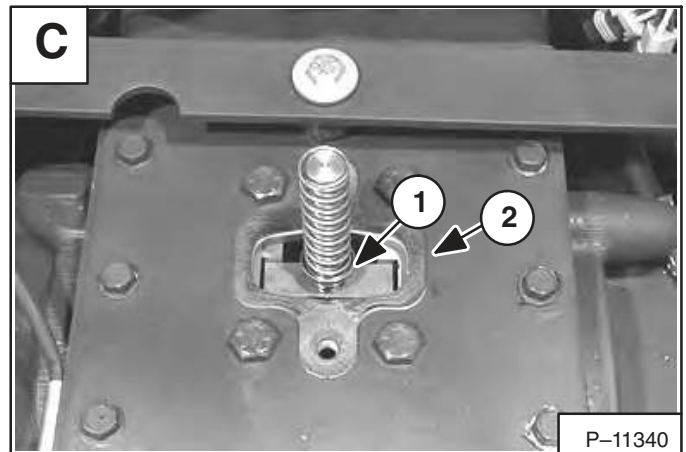

Install a new DO NOT MODIFY sta-strap (Item 3) [D] (P/N 6665527) on the electric solenoid connector.

Install the control panel. (See Page 3–1.)

Install the engine speed control. (See Page 7–1.)

Lower operator cab. (See Page 1–1.)

Perform the BICS™ inspection procedure. (See Page 8–1.)

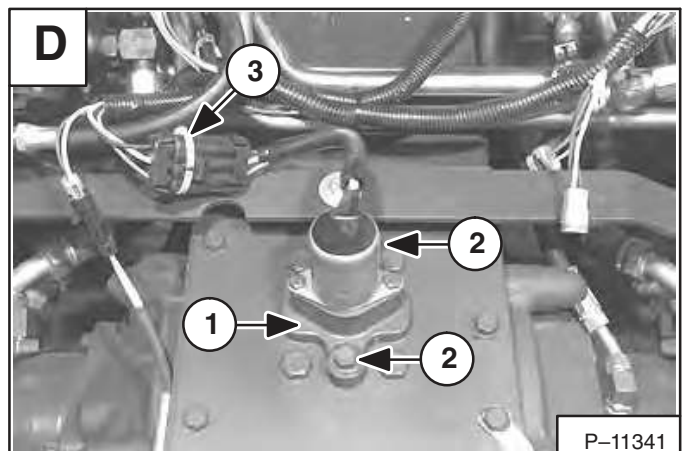

MOTOR CARRIER (Cont'd)

Assembly (Cont'd)

Put the snap ring (Item 1) [A] over the end of the sprocket shaft.

NOTE: Use the snap ring pliers to spread the snap ring so it will fit over the sprocket shaft.

Using the press and driver tools, press the snap ring (Item 1) [A] over the sprocket.

Press the snap ring on until it snaps into the groove on the shaft.

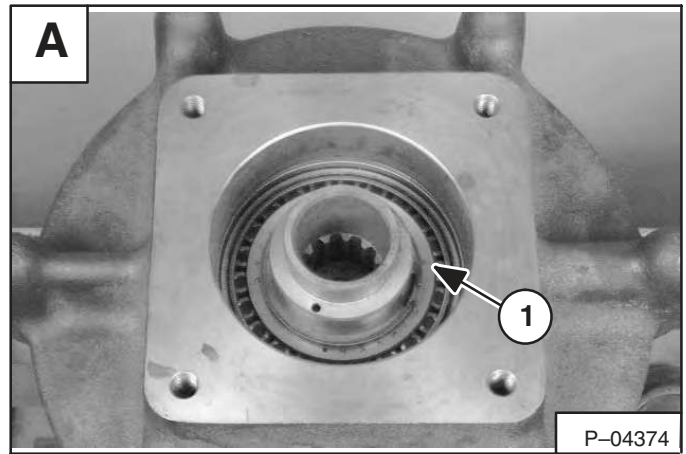

Put a new shaft seal (Item 1) [B] on the sprocket shaft.

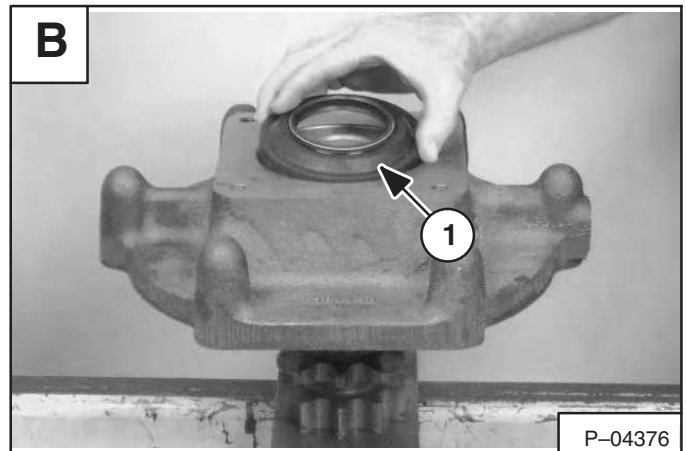

Use MEL1420 Carrier Seal Tool (Item 1) [C] and install the shaft seal.

Hit the tool with a hammer until the seal is fully seated on the carrier shaft [C].

Refer to *SHAFT SEAL REPLACEMENT* Page 4-11 for complete shaft seal installation procedure.

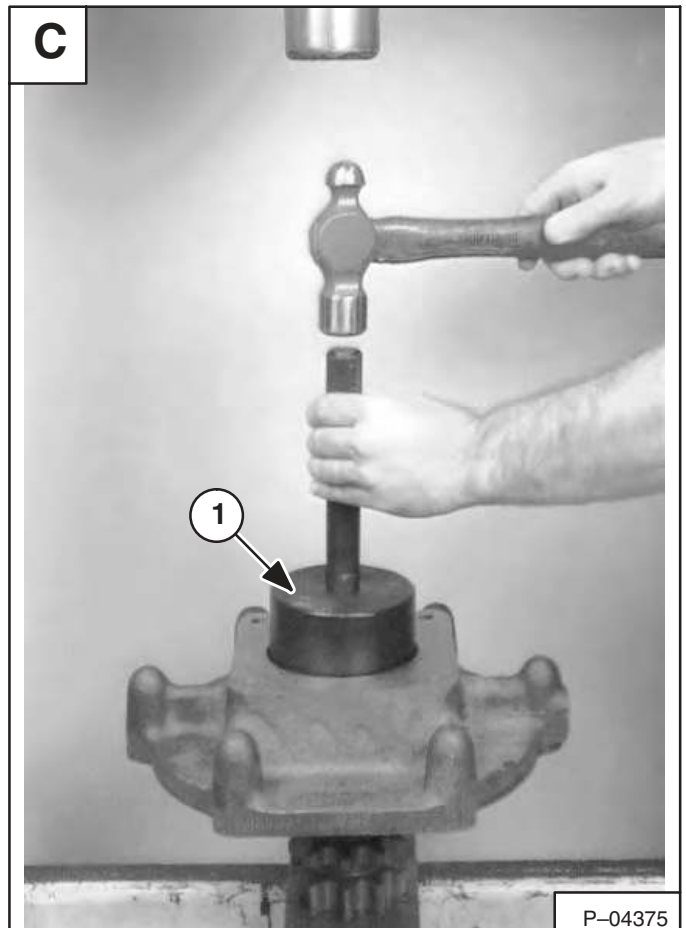

MAIN FRAME

	Page Number
BOB-TACH	
Bob-Tach Stops	5-19
Bob-Tach Lever And Wedge	5-18
Removal And Installation	5-16
FUEL TANK	
Fuel Level Sender	5-26
Removal And Installation	5-25
LIFT ARM LINK	
Removal And Installation	5-22
LIFT ARMS	
Removal And Installation	5-20
OPERATOR CAB	
Removal And Installation	5-13
OPERATOR CAB GAS CYLINDER	
Disassembly And Assembly	5-12
Removal And Installation	5-11
OPERATOR SEAT	
Removal And Installation	5-15
REAR DOOR	
Bumper Removal And Installation (2 piece door)	5-29
Door Latch Removal And Installation	5-29
Door Latch And Catch Adjustment	5-30
Hood Removal And Installation (2 piece door)	5-29
Removal And Installation (2 piece door)	5-27
Removal And Installation (1 piece door)	5-28
REAR GRILL	
Removal And Installation	5-24
REAR LIGHTS	
Removal And Installation	5-31
SEAT BAR (W/COMPRESSION SPRINGS)	
Assembling Components	5-10
Compression Spring Disassembly And Assembly	5-10
Removal And Installation	5-7
SEAT BAR (W/GAS CYLINDER)	
Assembly	5-5
Compressing The Gas Cylinder	5-6
Removal And Installation	5-3

MAIN FRAME

TIGHTEN ALL HARDWARE PER SIZE T O GRADE 5 TORQUE (SEE STANDARD TORQUE SPECIFICATIONS FOR BOL TS, SECTION 9) UNLESS OTHERWISE SPECIFIED.

OPERATOR CAB GAS CYLINDER

Removal And Installation

⚠

WARNING

Cylinder contains high pressure gas. Do not open. Opening cylinder can release rod and cause injury or death.

W-2113-0288

Remove the operator cab stop (Item 1) (both sides) [A].

NOTE: If the operator cab is equipped with a rear window, the rear grill and rear grill mounts must be removed to prevent window damage. See Page 5-24.

Raise the operator cab See Page 1-1, to release the tension on the gas cylinder (Item 1) [B].

Install a hoist to the cab to prevent the cab from falling forward [B].

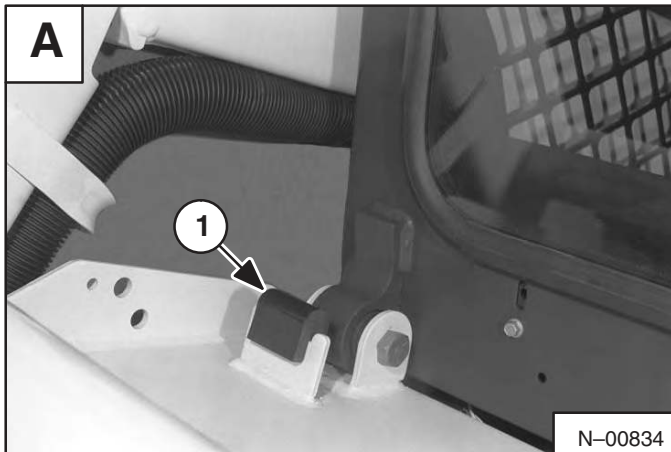

Remove the bolts (Item 1) [C] from the gas cylinder mounting bracket.

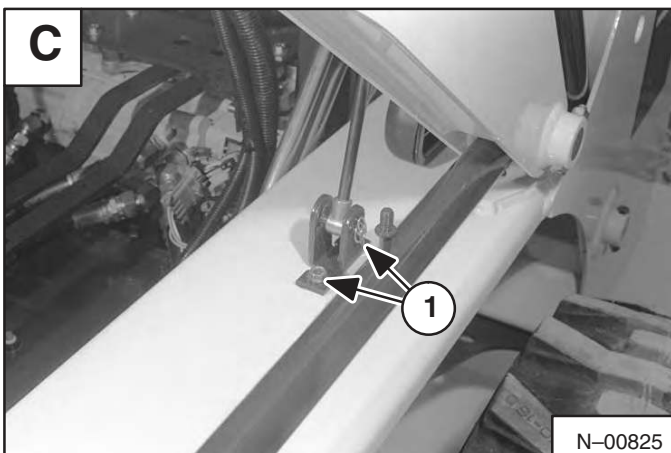

CLICK HERE TO **DOWNLOAD** THE COMPLETE MANUAL

- Thank you very much for reading the preview of the manual.
- You can download the complete manual from: www.heydownloads.com by clicking the link below



- Please note: If there is no response to **CLICKING** the link, please download this PDF first and then click on it.

CLICK HERE TO **DOWNLOAD** THE COMPLETE MANUAL

LIFT ARMS (Cont'd)

Removal And Installation (Cont'd)

Remove the retainer bolt and nut from the lift cylinder rod end pivot pin (Item 1) [A] (both sides).

Installation: Tighten the retainer bolt and nut to 18–20 ft.-lbs. (24–27 Nm) torque.

Raise the operator cab. (See Page 1–1.)

Remove the grease fitting (Item 2) [A] (both sides).

Installation: Reinstall the grease fitting (Item 2[A]) when lift arms are reinstalled (Both sides).

Connect a nylon lift strap, chain and chain hoist to the lift arms. (See Figure [C] for reference.)

Use a drift punch and hammer, remove the lift cylinder rod end pivot pin (Item 1) [A] (both sides).

Remove the retainer bolt and nut (Item 1) [B] from the stabilizer pivot pin (both sides).

Installation: Tighten the retainer bolt and nut to 18–20 ft.-lbs. (24–27 Nm) torque.

Use a drift punch and hammer, remove the stabilizer pivot pin (Item 1) [B] (both sides).

Lift the lift arms with the chain hoist and move them away from the loader [C].

Reverse the removal procedure to install the lift arms on the loader.

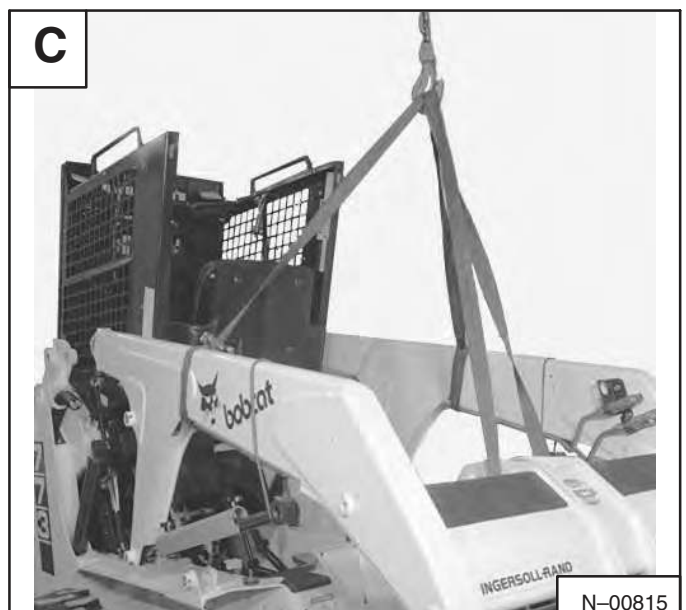
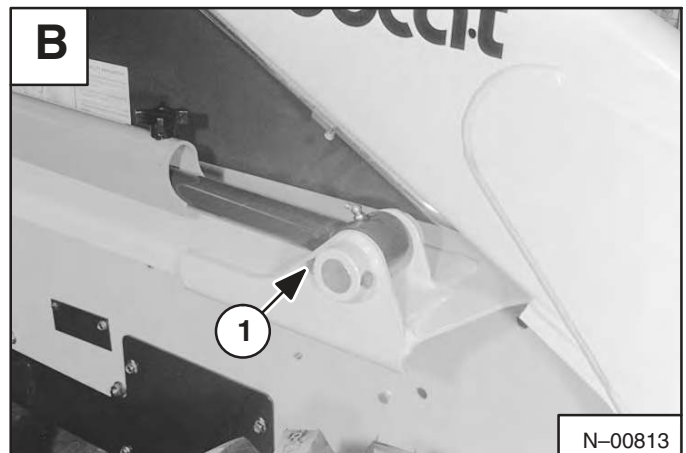
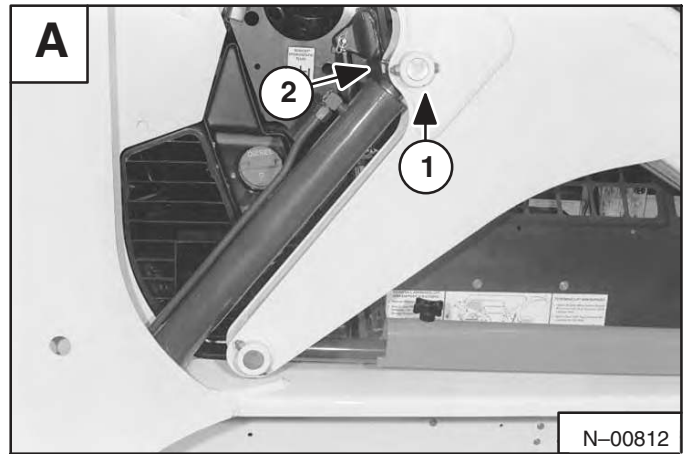

REAR LIGHTS

Rear Lights Removal and Installation (One Piece Door)

Remove the bulb assembly (Items 1 & 2) [A] from the light housing (Item 3) [A] by turning bulb assembly a 1/4 turn.

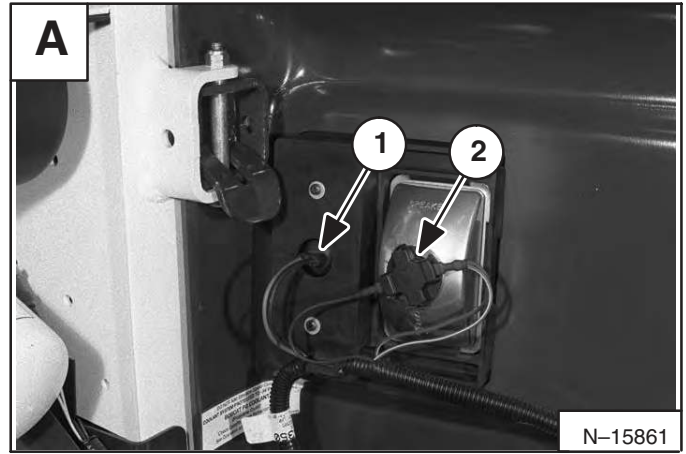

Using care press the rear light and housing from the door [B].

Reverse this procedure for installation.



CONTROLS HARNESS - 6710365

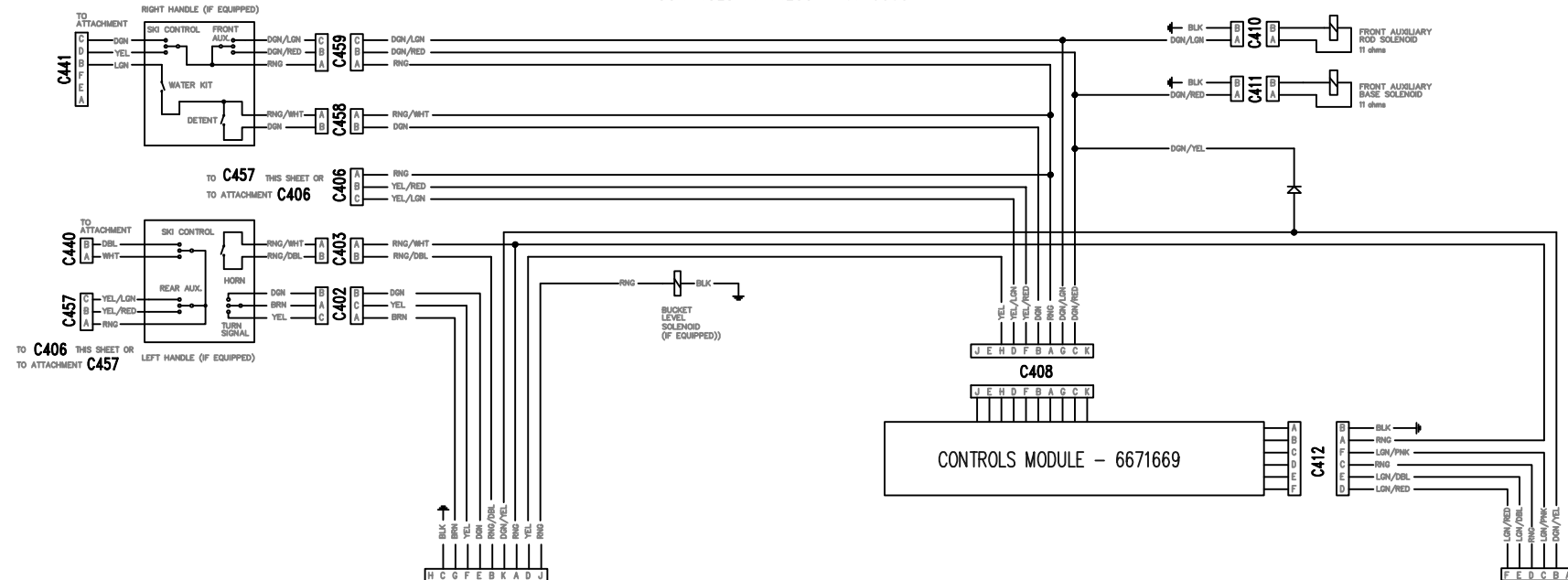

BICS CONTROLLER HARNESS - 6706828 OR 6710312

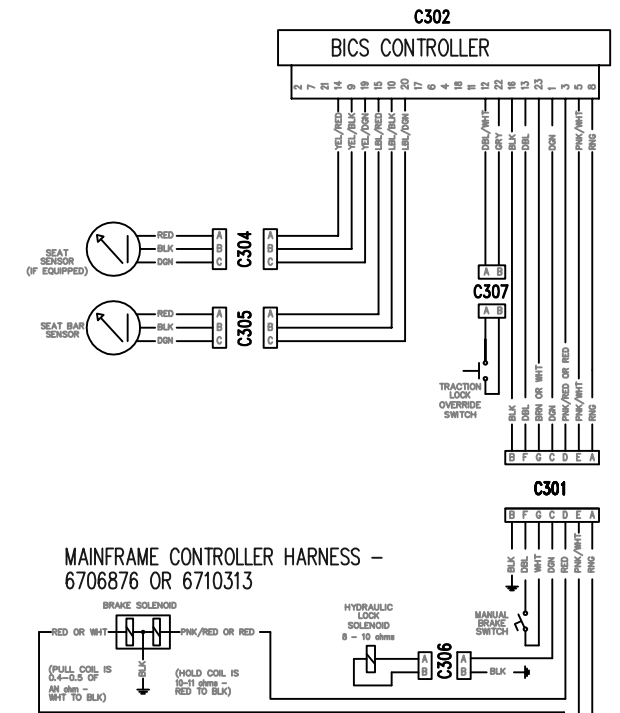

MAINFRAME CONTROLLER HARNESS - 6706876 OR 6710313

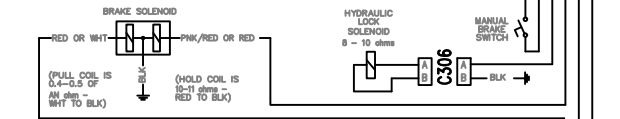

C106 C107

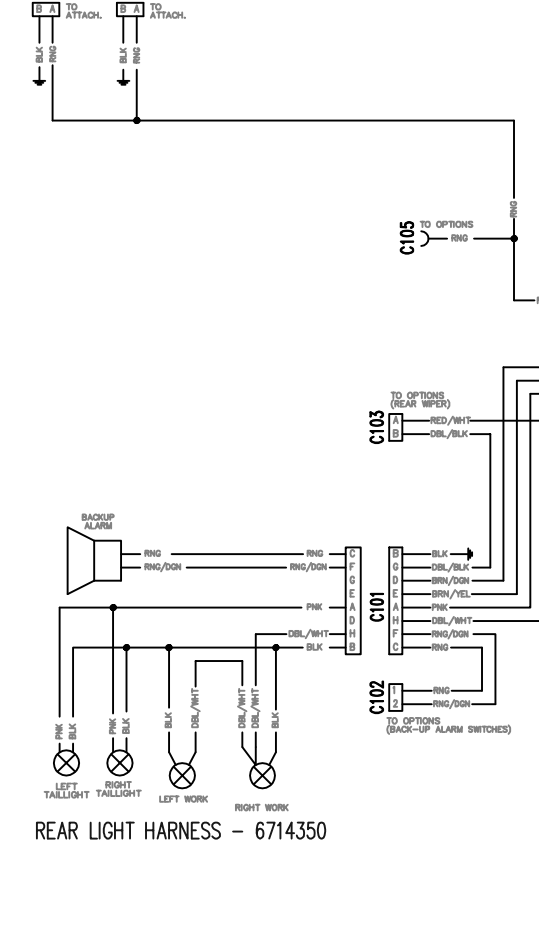

REAR LIGHT HARNESS - 6714350

C109

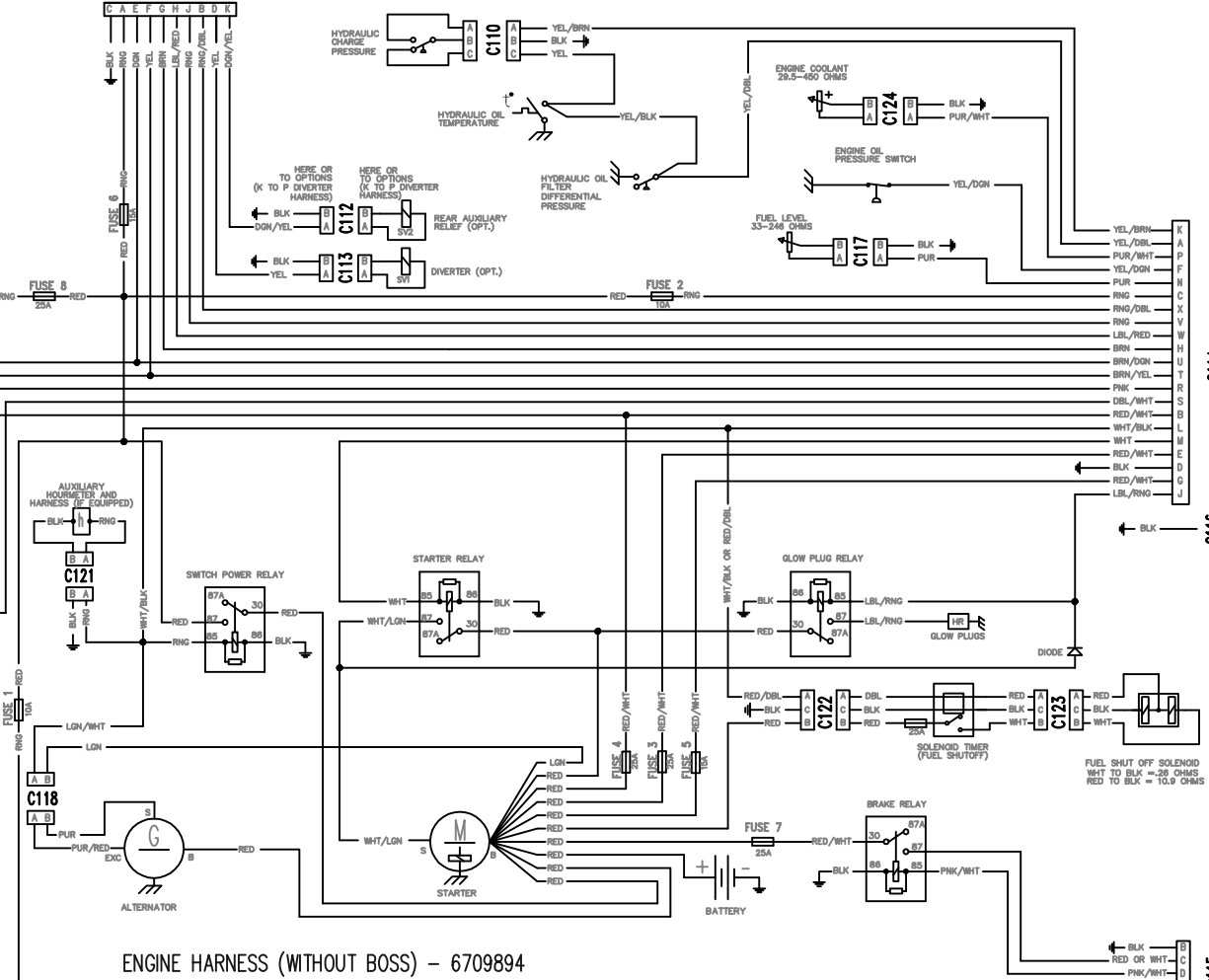

ENGINE HARNESS (WITHOUT BOSS) - 6709894

C203

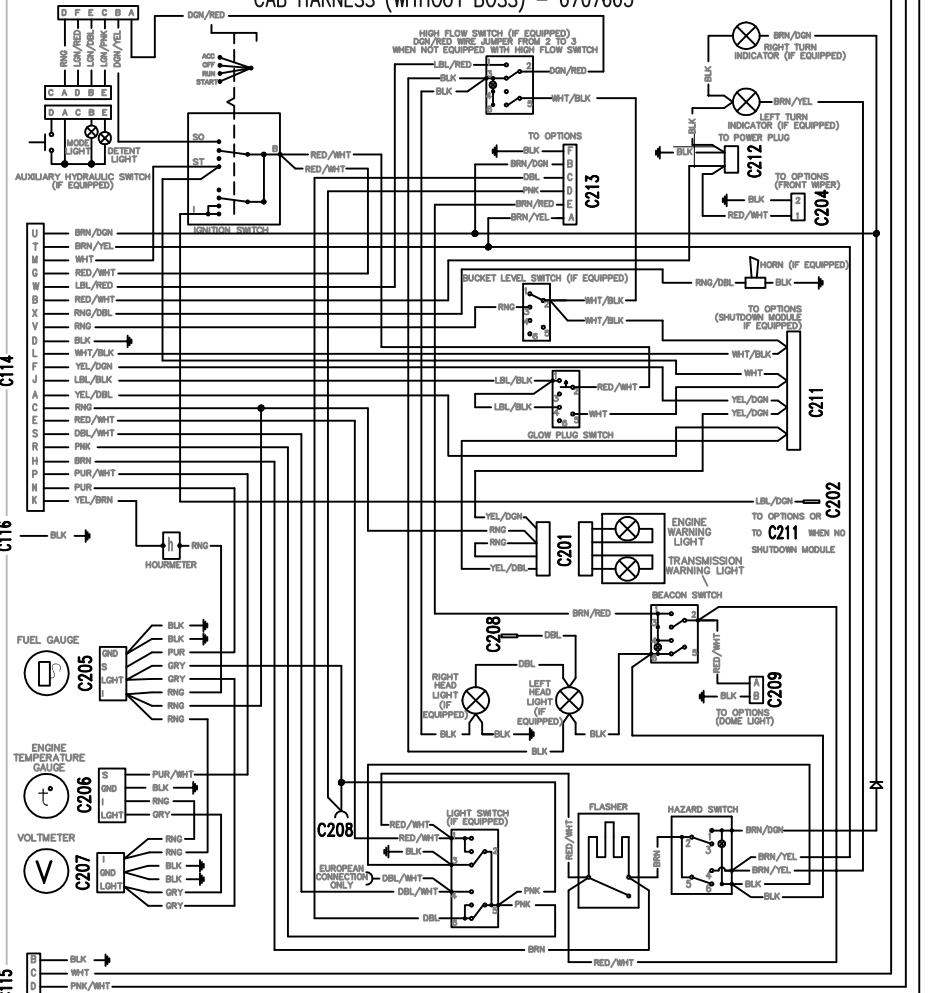

CAB HARNESS (WITHOUT BOSS) - 6707665

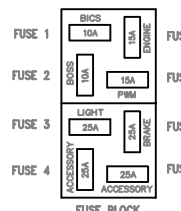

WIRES CONNECT BY LETTER ACROSS CONNECTORS

SOME CONNECTOR BODIES NOT SHOWN FOR DRAWING CLARITY

RED = RED
 RNG = BLACK
 BLK = ORANGE
 LBL = LIGHT BLUE
 DBL = DARK BLUE
 LGN = LIGHT GREEN
 DGN = DARK GREEN
 YEL = YELLOW
 WHT = WHITE
 BRN = BROWN
 TAN = TAN
 PUR = PURPLE
 GRY = GREY

CONTROLS HARNESS - 6712136

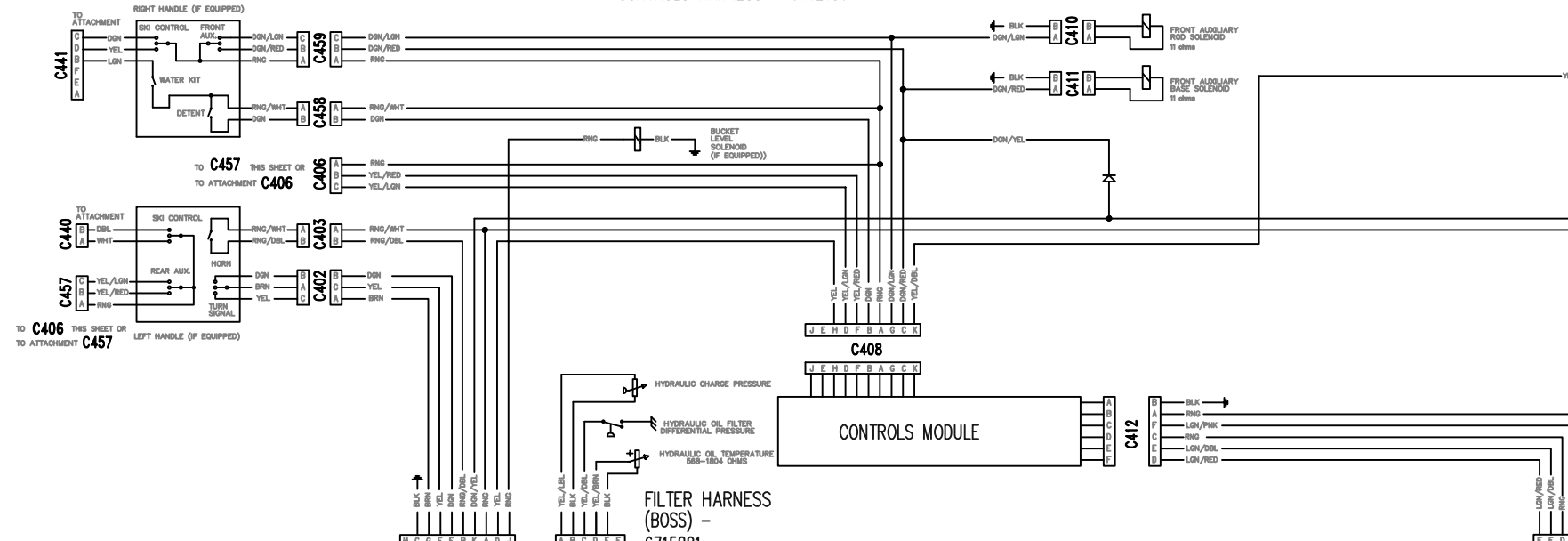

BICS CONTROLLER HARNESS - 6712134

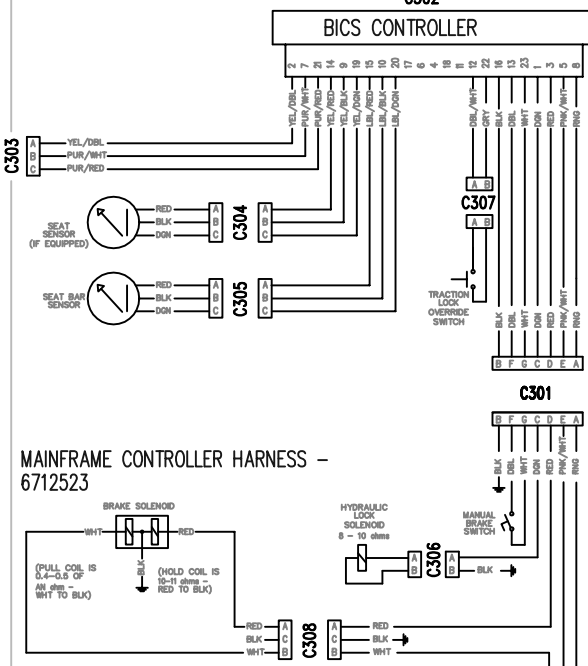

MAINFRAME CONTROLLER HARNESS - 6712523

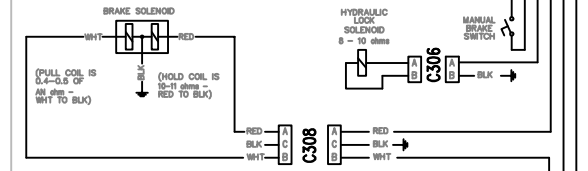

FILTER HARNESS (BOSS) - 6715881

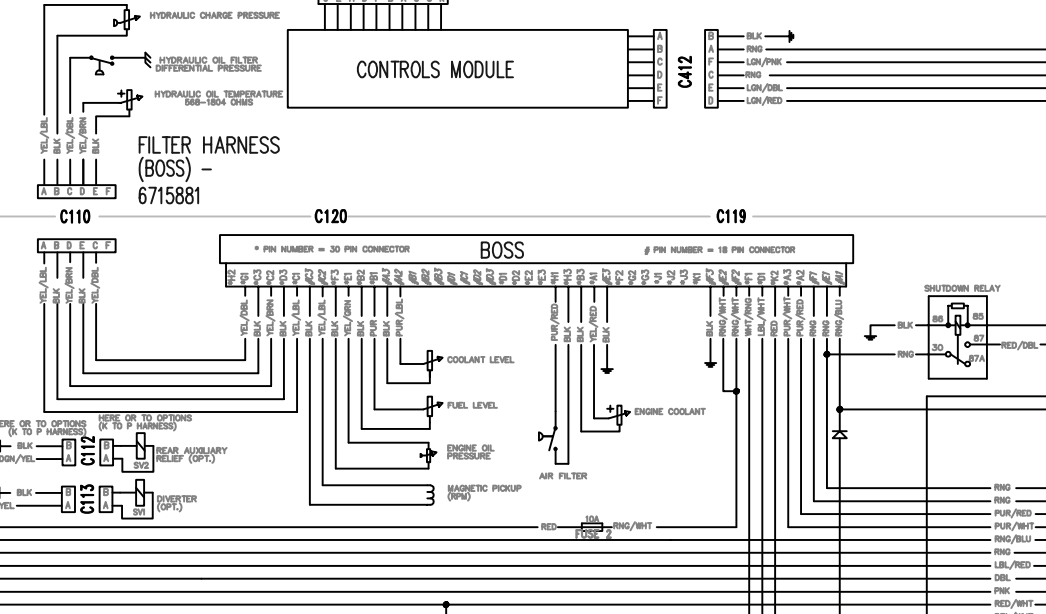

ENGINE HARNESS (BOSS) - 6715893

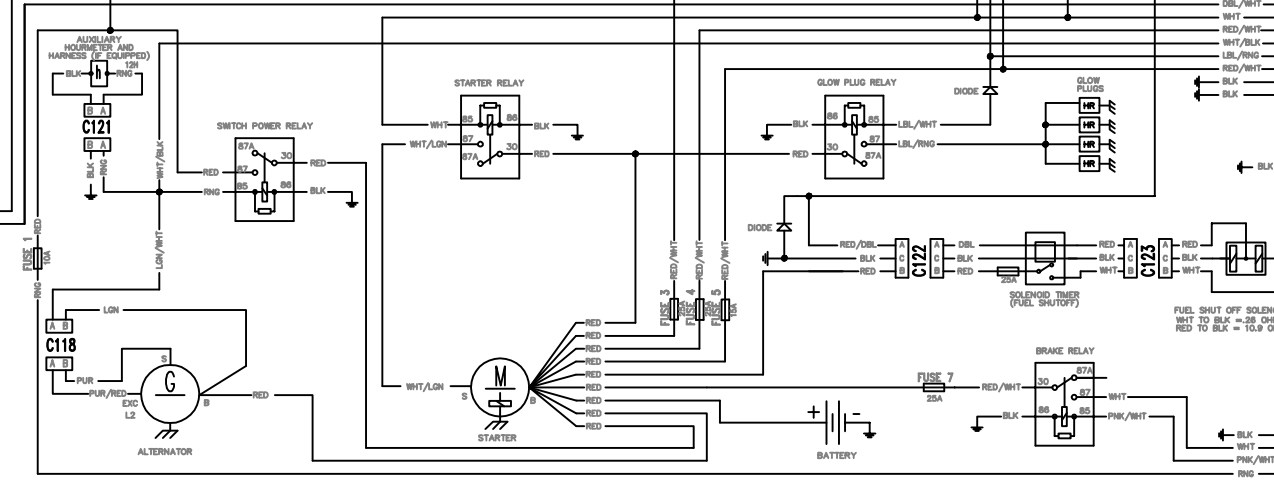

REAR LIGHT HARNESS - 6714350

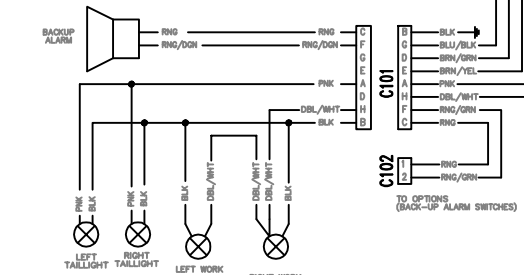

CAB HARNESS (BOSS) - 6711774

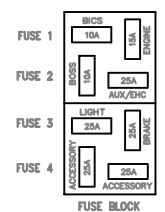
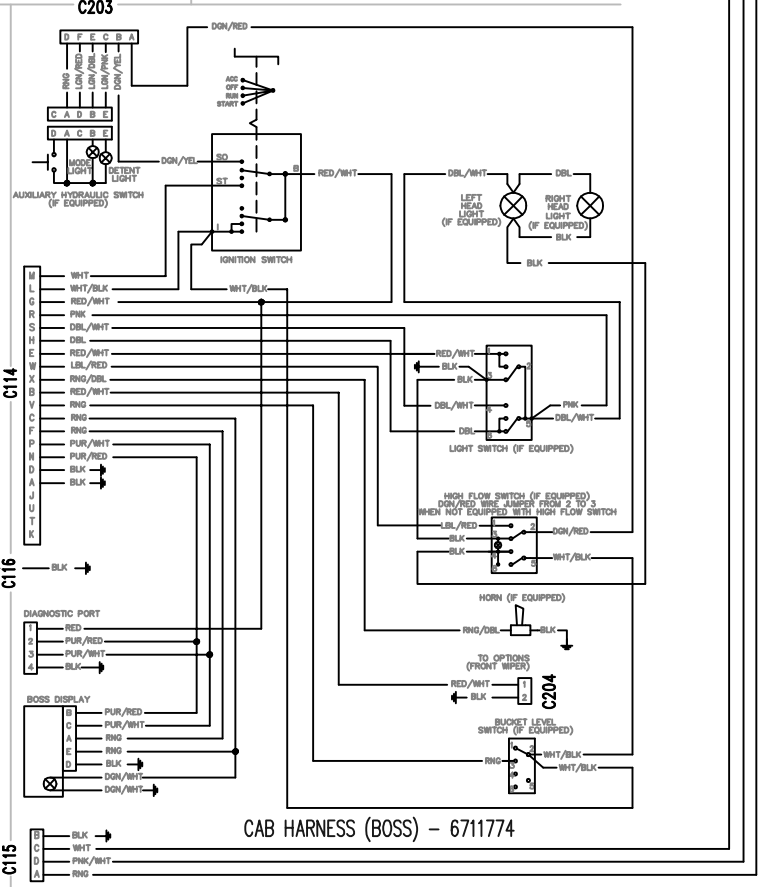

WIRES CONNECT BY LETTER ACROSS CONNECTORS

SOME CONNECTOR BODIES NOT SHOWN FOR DRAWING CLARITY

- RED = RED
- ORNG = ORANGE
- BLK = BLACK
- LGL = LIGHT BLUE
- LBL = LIGHT BLUE
- DBL = DARK BLUE
- LGN = LIGHT GREEN
- DGN = DARK GREEN
- YEL = YELLOW
- PNK = PINK
- WHT = WHITE
- BRN = BROWN
- TAN = TAN
- PUR = PURPLE
- GRY = GREY

773 - WIRING SCHEMATIC
 ATTACHMENT CONTROL OPTION
 S/N 509635001-38679
 S/N 509616001-16311
 (PRINTED JUNE 2001)
 MC2586

ATTACHMENT CONTROLS HARNESS - 6705901

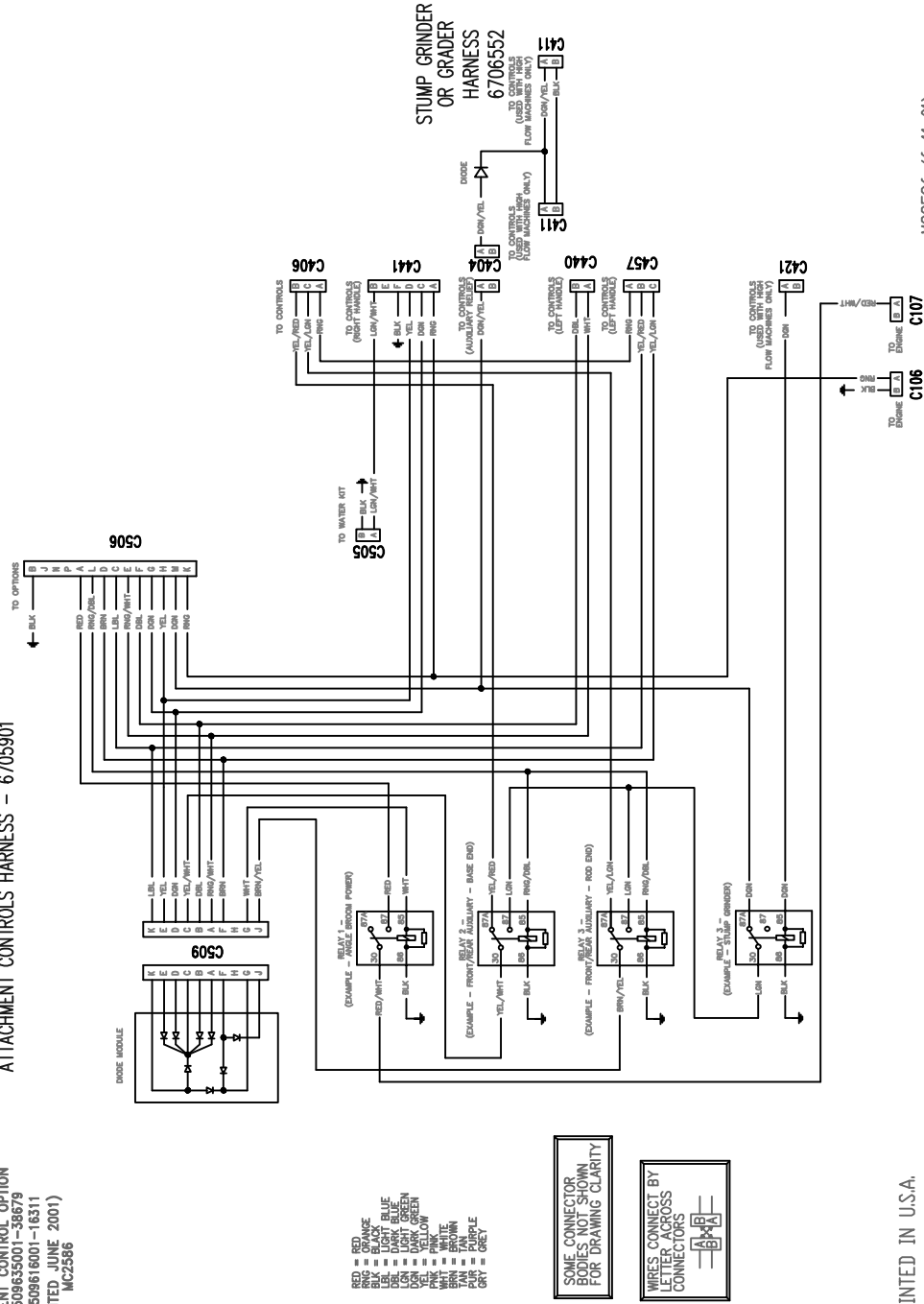

PRINTED IN U.S.A.

MC2586 (6-11-01)

BATTERY

Removal And Installation

WARNING

Batteries contain acid which burns eyes and skin on contact. Wear goggles, protective clothing and rubber gloves to keep acid off body.

In case of acid contact, wash immediately with water. In case of eye contact get prompt medical attention and wash eye with clean, cool water for at least 15 minutes.

If electrolyte is taken internally drink large quantities of water or milk! DO NOT induce vomiting. Get prompt medical attention.

W-2065-1296

Open the rear door.

Disconnect the negative (-) battery cable (Item 1) [A] from the battery.

Disconnect the positive (+) cable (Item 1) [B] from the battery.

Remove the battery holddown clamp (Item 1) [C].

Remove the battery from the loader [D].

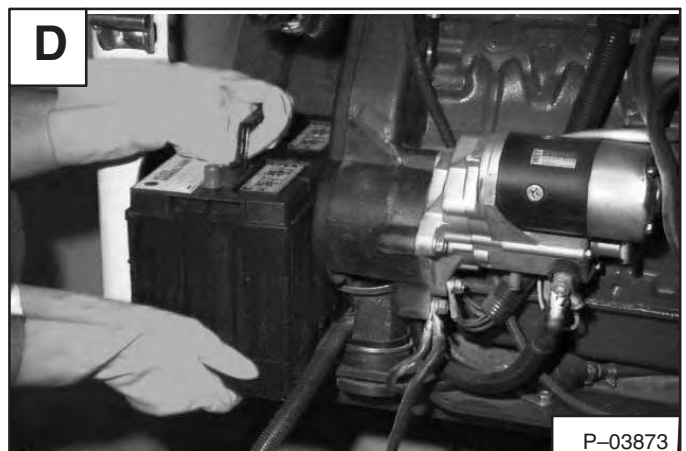
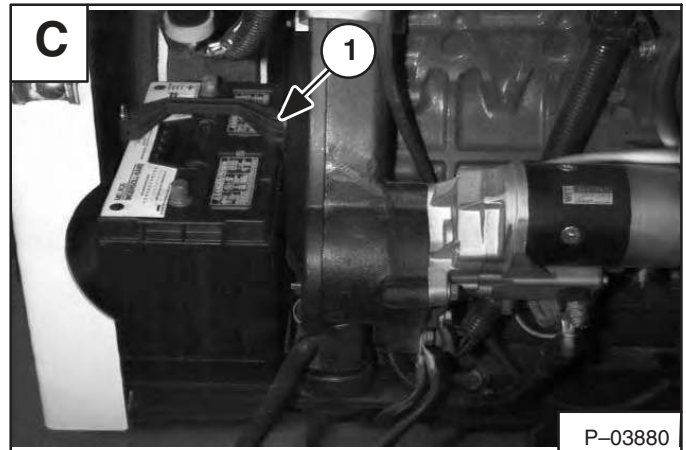
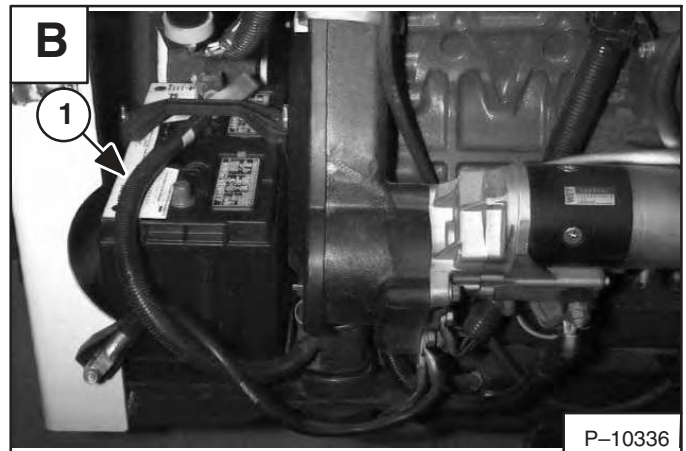
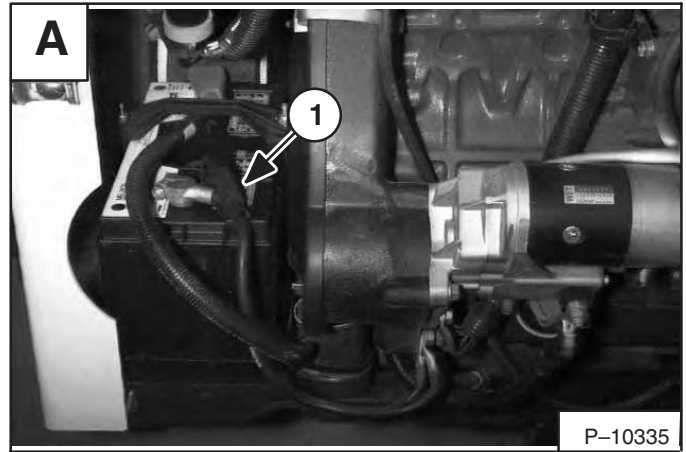

STARTER (DELCO REMY) (Cont'd)

Parts Identification

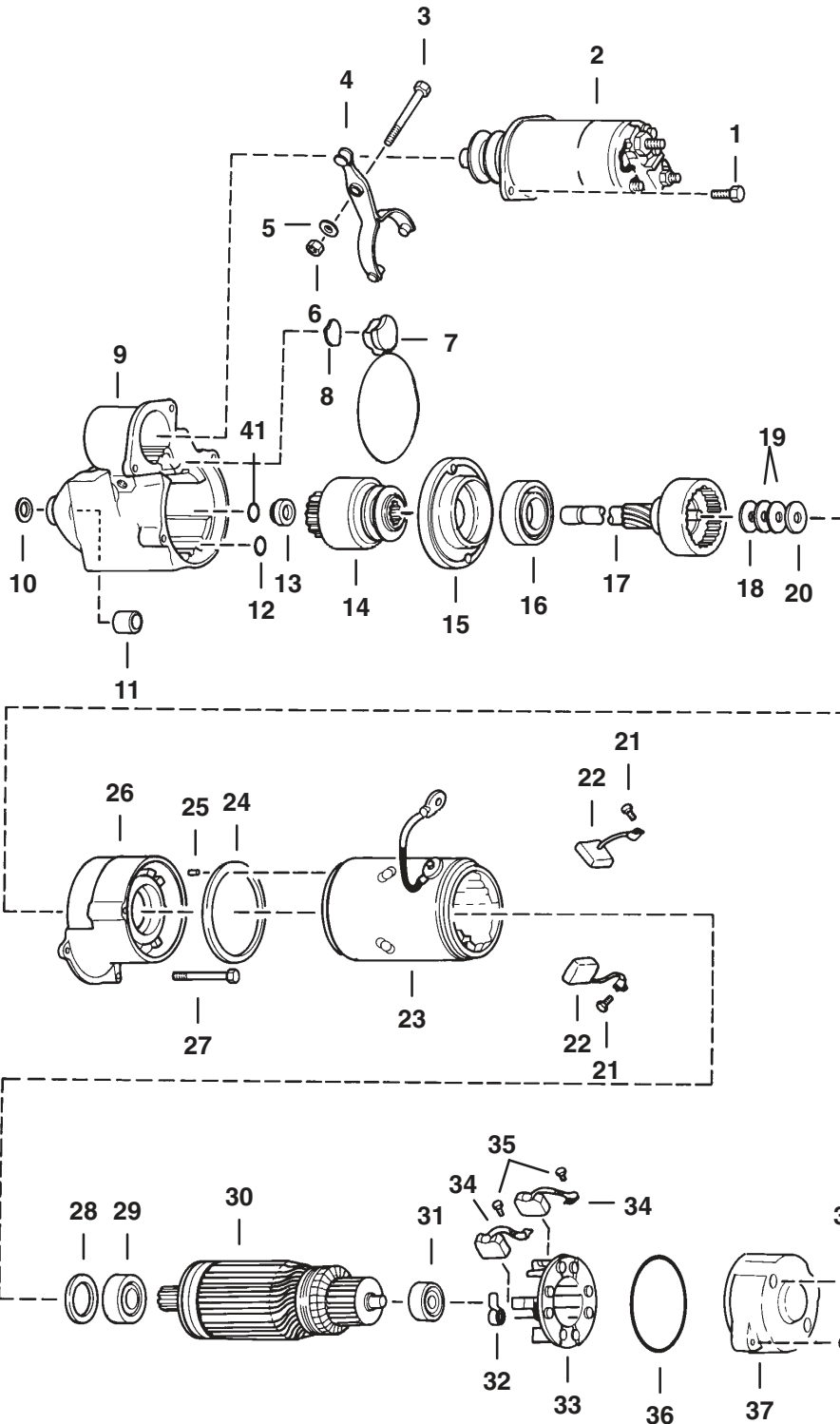

- 1. Screw
- 2. Solenoid
- 3. Bolt
- 4. Lever
- 5. Washer
- 6. Nut
- 7. Plug
- 8. Washer
- 9. Housing Drive
- 10. Washer
- 11. Bushing
- 12. Ring
- 13. Stop
- 14. Drive
- 15. Drive Support
- 16. Support
- 17. Drive Shaft
- 18. Washer
- 19. Washer
- 20. Washer
- 21. Screw
- 22. Brush
- 23. Frame Assy.
- 24. Gasket
- 25. Pin
- 26. Armature Support
- 27. Bolt
- 28. Spacer
- 29. Bearing
- 30. Armature
- 31. Bearing
- 32. Spring
- 33. Holder Assy.
- 34. Brush
- 35. Screw
- 36. O-ring
- 37. Frame
- 38. Washer
- 39. Screw
- 40. Bolt
- 41. Ring

STARTER (DENSO) (Cont'd)

Inspection And Repair

Inspect the brush cover for discoloration, indication the starter has been overheated.

Inspect the pinion teeth for wear and damage.

Armature Short-Circuit Test: Use a growler tester put the armature on the growler and hold a hack saw blade against the armature core while slowly rotating the armature [A]. A short circuited armature causes the blade to vibrate and be attracted to the core. An armature which is short-circuited must be replaced.

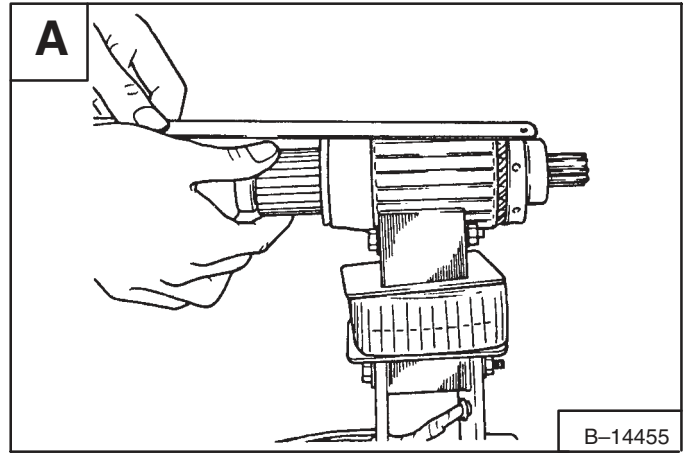

Armature Winding Ground Test: Use a circuit tester touch one probe to a commutator segment and the other probe to the armature core [B]. There should be no continuity. If there is continuity, the armature is grounded and must be replaced.

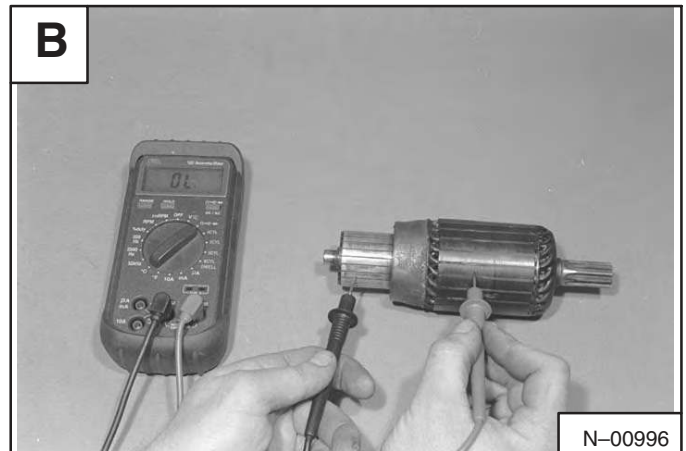

Armature Winding Continuity Test: Use a circuit tester, touch the probes to two commutator segments [C]. There should be continuity at any point. If there is no continuity the winding is open-circuited, replace the armature.

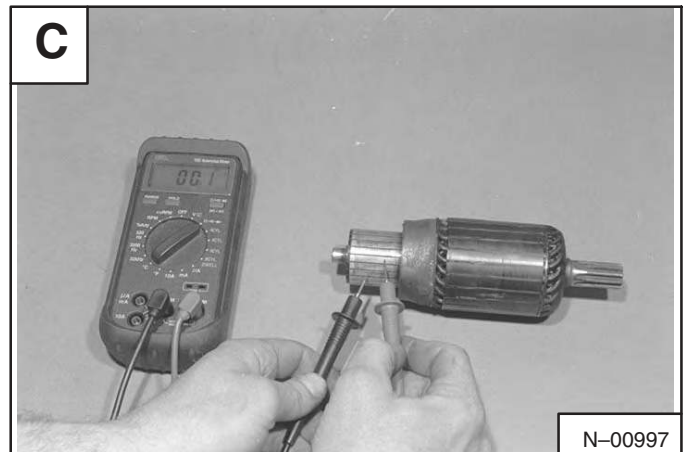

Commutator Run-Out Test: check the commutator run-out as shown in [D].

Service Limit – 0.020 inch (0,4 mm)

If the commutator exceeds the service limit, repair as needed.

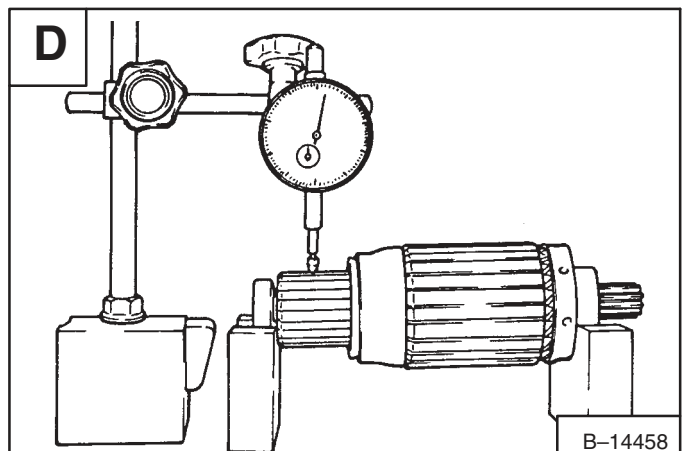

STANDARD INSTRUMENT PANEL

Removal And Installation

Pry the rubber light mount loose from the operator cab (both sides) [A].

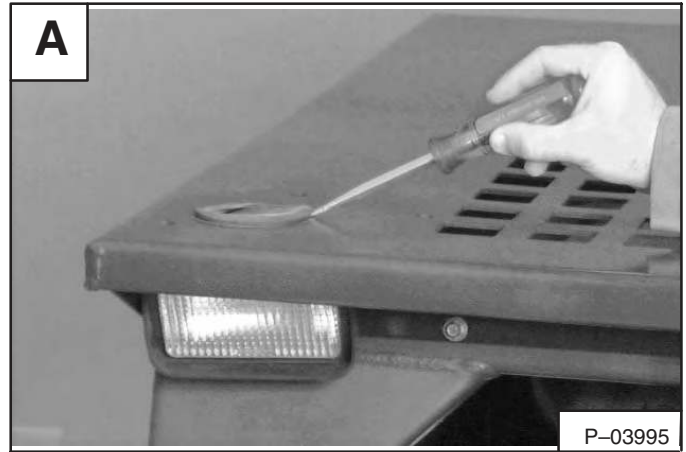

Lower the light from the operator cab and locate the three instrument panel mounting bolts (Item 1) [B] (both sides).

Remove the three mounting bolts (Item 1) [B].

Installation: Be careful to not overtighten the instrument panel mounting bolts to prevent stripping of the threaded holes in the panels.

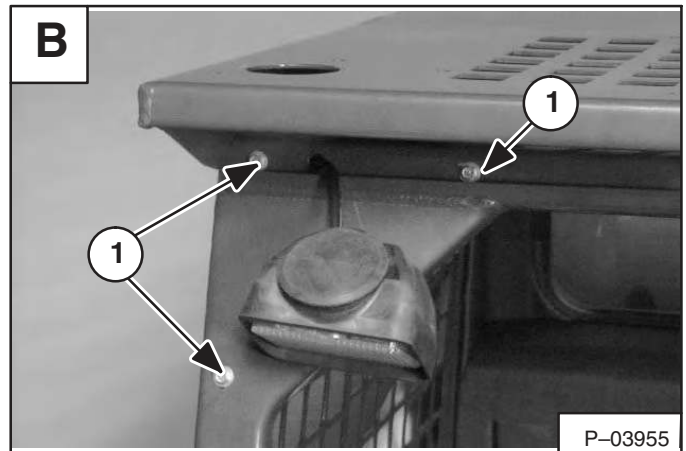

Pull the left instrument panel down and disconnect the wire harness connectors from the panel. Remove the panel [C].



Repeat steps [A] and [B]. Pull the right instrument panel down and disconnect the wire harness connectors from the panel. Remove the panel [D].

Reverse the removal procedure to install the instrument panel.



RADIATOR (Cont'd)

Removal And Installation (Cont'd)

Remove the two rubber stops (Item 1)[A] from the top of the radiator.

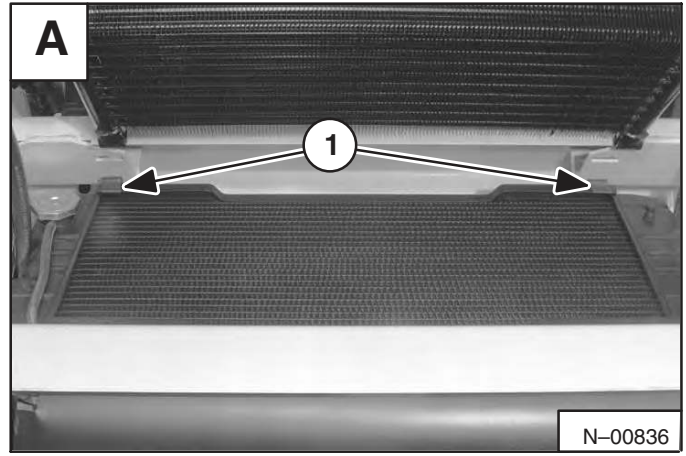

NOTE: Photo's may appear different but the procedure is the same.

Lift the radiator up and remove it from the loader [B].

Reverse the removal procedure to install the radiator.



FAN GEARBOX (Cont'd)

Disassembly (Cont'd)

Short Housing

Remove the end cap [A].

Use care not to damage the housing.



WARNING

AVOID INJURY OR DEATH

Wear safety goggles to prevent eye injury when drilling or grinding.

W-2108-1186

Drill an 1/8 inch (3 mm) hole in the seal. Use a slide hammer tool to remove the seal [B].

Remove the large snap ring from the flange end of the housing [C].

Remove the large shims from the housing [D].

NOTE: Use the same size and thickness of shims during assembly.

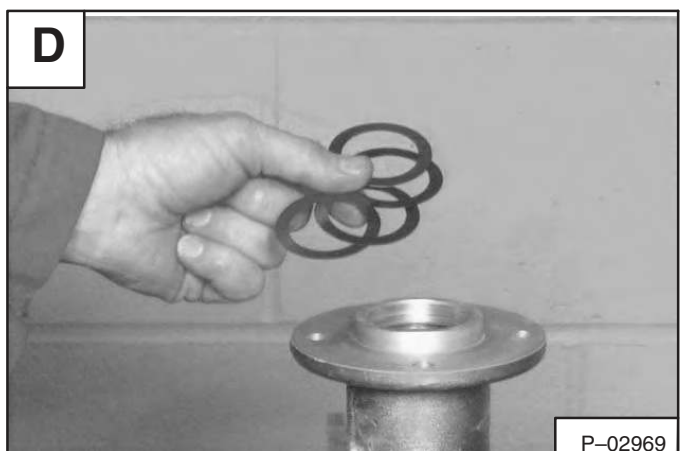
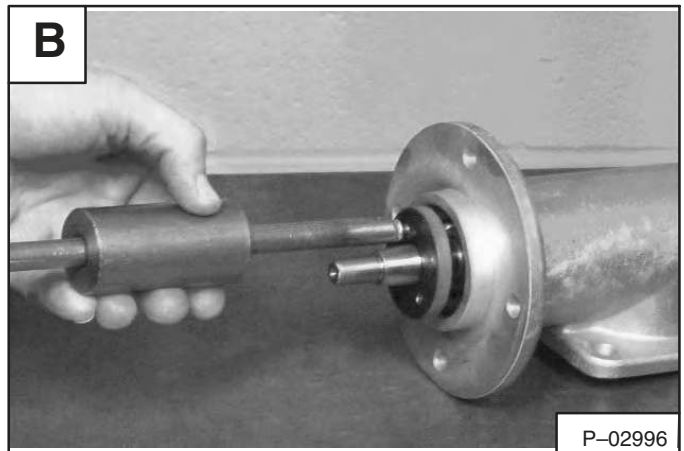

FAN GEARBOX (Cont'd)

Checking Backlash (Cont'd)

When the backlash is correct, install the seals, cap and gear oil as follows:

Remove the bolts from the flanges and separate the two housings.

Put liquid adhesive (LOCTITE #242) on the outside diameter of the seal(s) **[A]**.

Install the seal(s) flush with the housing surface **[B]** & **[C]**.

Clean any oil from the flange surface.

Install the long housing on the short housing flange.

Install the four bolts and part number tag.

Install and tighten the nuts to 25–28 ft.-lbs. (34–38 Nm) torque.

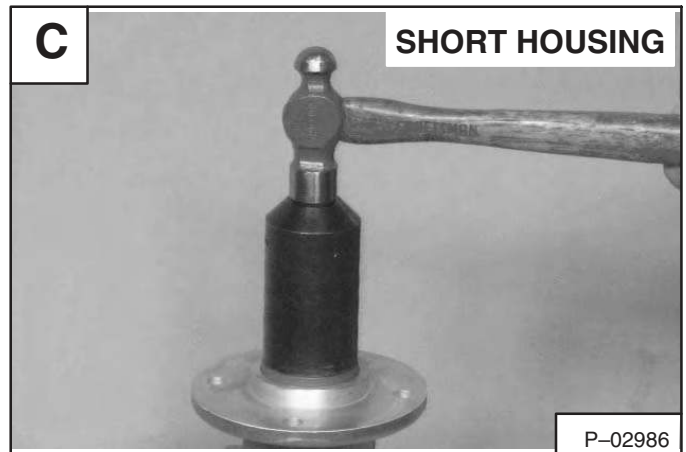
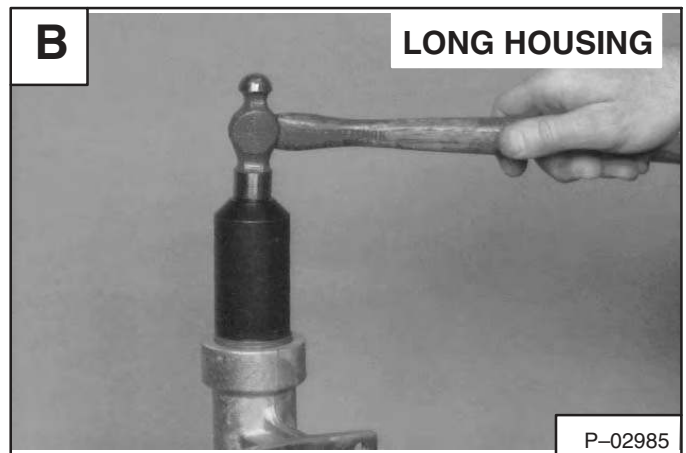
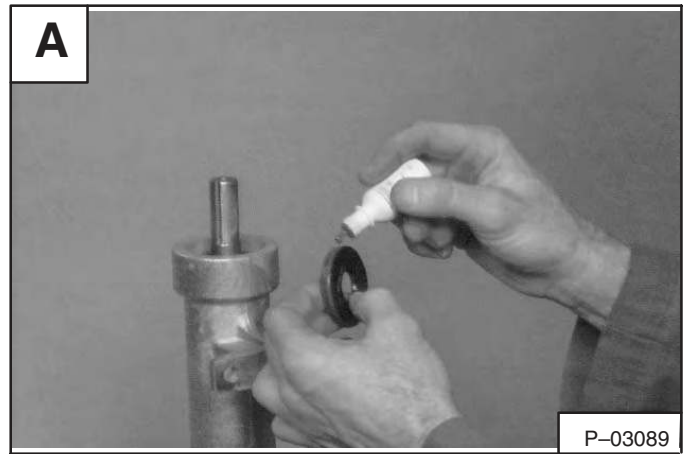

GLOW PLUGS

Checking The Glow Plugs

Disconnect the glow plug cables and leads.

Use an ohmmeter to check the glow plugs **[A]**.



Touch one probe to the end of the glow plug and the other probe to the body of glow plug **[B]**.

The reading must be between 1 and 2 ohms **[A]**. If the resistance is infinite, the coil of the glow plug is broken.

Repeat the procedure for each glow plug.

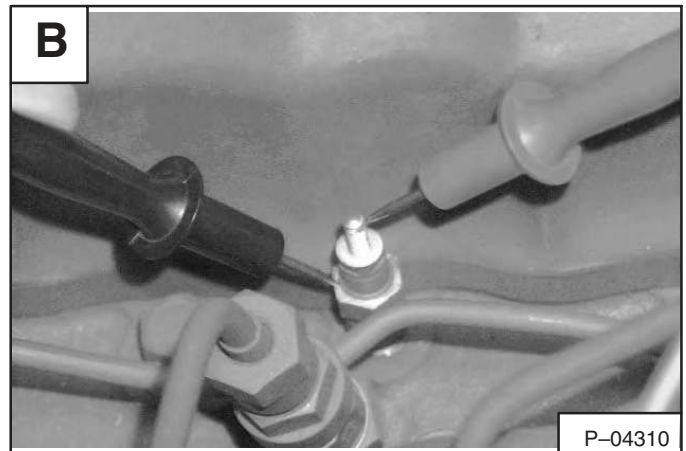

CYLINDER HEAD

Removal And Installation

Remove the nuts from the valve cover, remove the valve cover and gasket [A].

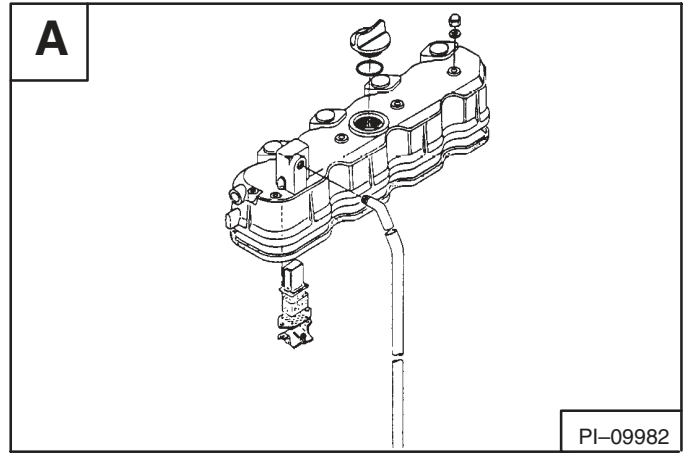

Remove the fuel injector nozzles. (See Page 7-44.)

Remove the glow plugs. (See Page 7-38.)

Remove the belt shield. (See Page 3-1.)

Remove the alternator. (See Page 6-1.)

Remove the rocker arm and shaft assembly (Item 1) [B].

Remove the push rods (Item 2) [B].

Remove the intake and exhaust manifolds.

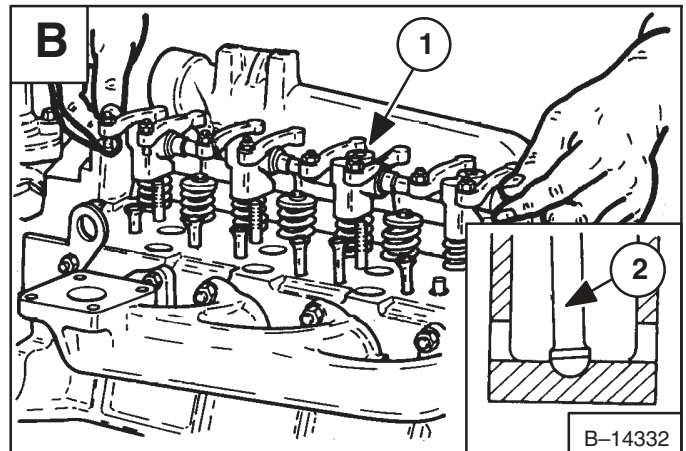

Remove the water return hose [C].

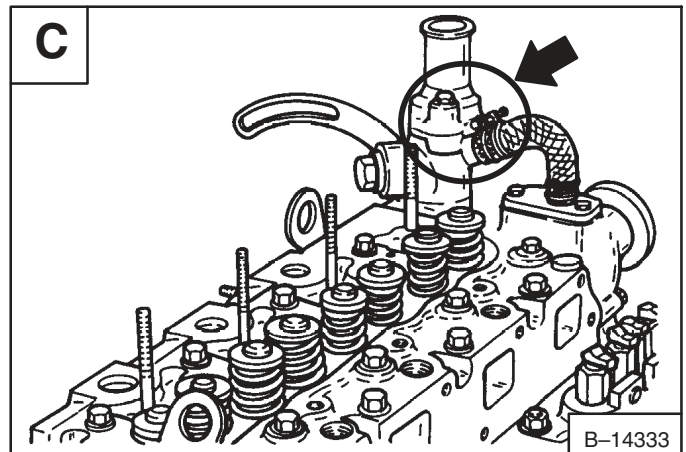

Remove the cylinder head bolts in order of #18 to #1 [D].

Installation: Put oil on the bolt threads. Tighten the bolts in the correct sequence to 67-72 ft.-lbs. (91-98 Nm) torque.

NOTE: Retighten the cylinder head bolts in the correct sequence after the engine has been run for 30 minutes.

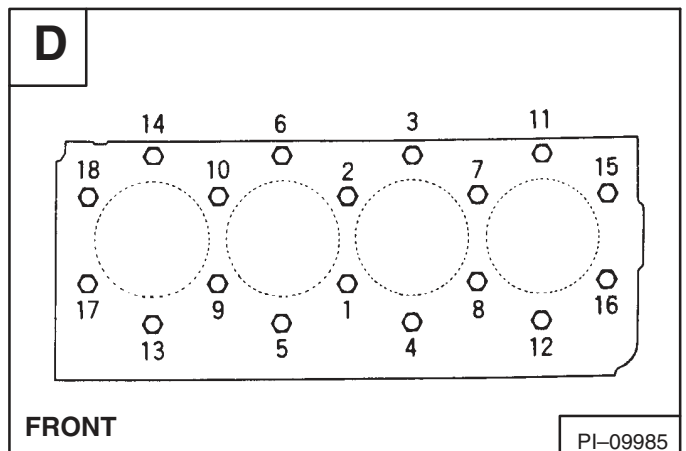

IDLER GEAR AND CAMSHAFT (Cont'd)

Servicing The Camshaft

Measure the camshaft bearing in the engine block [A].

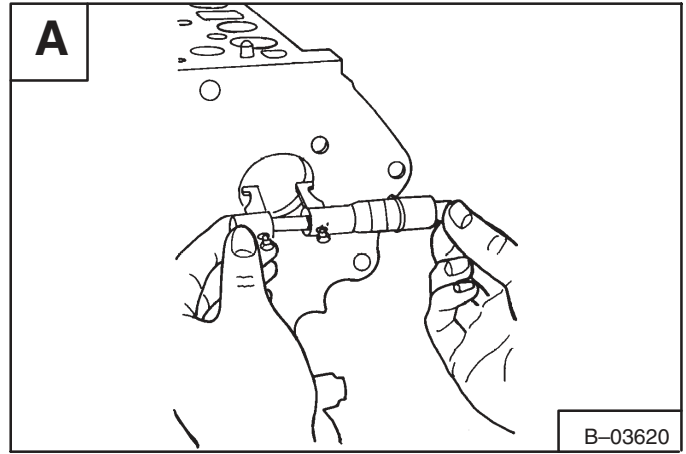

Measure the camshaft journal [B].

Calculate the oil clearance. If the clearance exceeds the allowable limit, replace the camshaft.

Bearing I.D. 1.575–1.576 inches (40,0–40,03 mm)
Journal O.D. . . . 1.572–1.573 inches (39,93–39,95 mm)
Oil Clearance of Camshaft
Journal 0.002–0.004 inch (0,05–0,09 mm)
Allowable Limit 0.006 inch (0,15 mm)

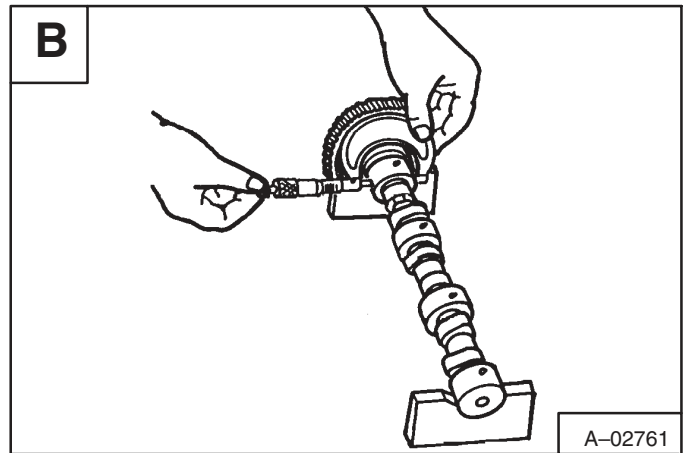

Measure the cam lobes at their highest point [C].

If the measurement is less than the allowable limit, replace the camshaft.

Cam Lobe Height 1.318 inches (33,47 mm)
Allowable Limit 1.316 inches (33,42 mm)

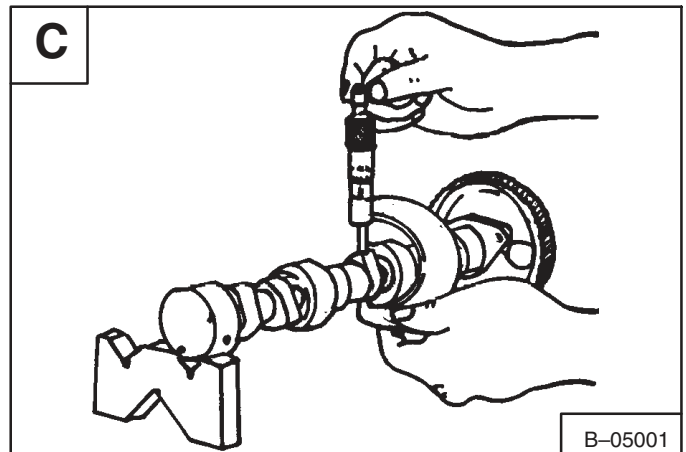

Put the camshaft in V-blocks. Install a dial indicator [D].

Turn the camshaft at a slow rate. If the misalignment exceeds the allowable limit, replace the camshaft.

Camshaft Alignment
Allowable Limit 0.003 inch (0,08 mm)

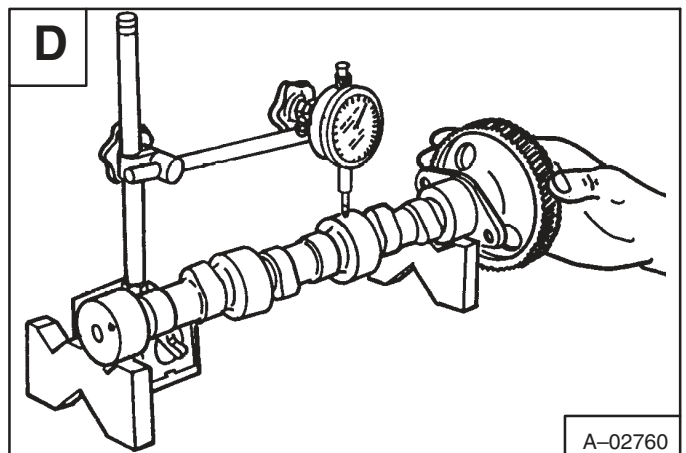

CRANKSHAFT AND BEARINGS

Removal And Installation

Remove the piston and connecting rod assemblies. (See Page 7–63.)

Remove the engine flywheel. (See Page 7–35.)

Remove the bolts which fasten the bearing case cover to the block.

Installation: Tighten the bearing case cover bolts to 13–15 ft.-lbs. (18–21 Nm) torque.

Install two bolts into the bearing case cover and pull the cover out [A].

Installation: When installing the cover (Item 1[B], make sure the casting mark (Item 2)[B] is in the down position.

Before removing the crankshaft/main bearings, check the end play. Install a dial indicator. Measure the end play by moving the crankshaft back and forth [C].

If the measurement exceeds the allowable limit, replace the thrust washers.

End Play 0.006–0.012 inch (0,15–0,31 mm)
Allowable Limit 0.020 inch (0,5 mm)

Remove the main bearing case bolt (Item 1) [D].

Installation: Make alignment of the bearing case hole (Item 2) [D] with the hole in the block. Put oil on the bolt threads and tighten to 51–54 ft.-lbs. (69–73 Nm) torque.

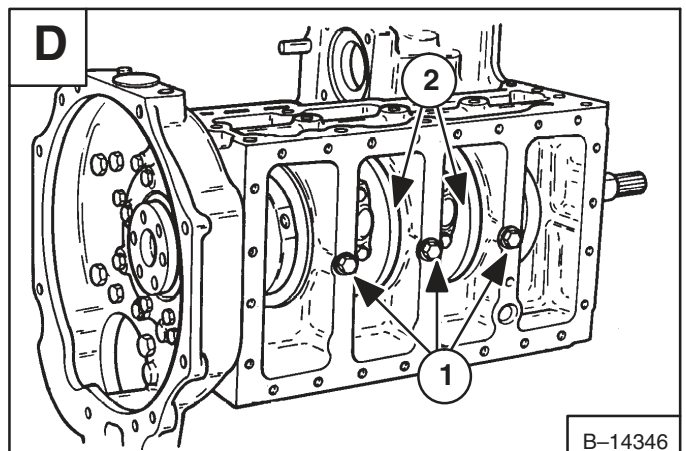
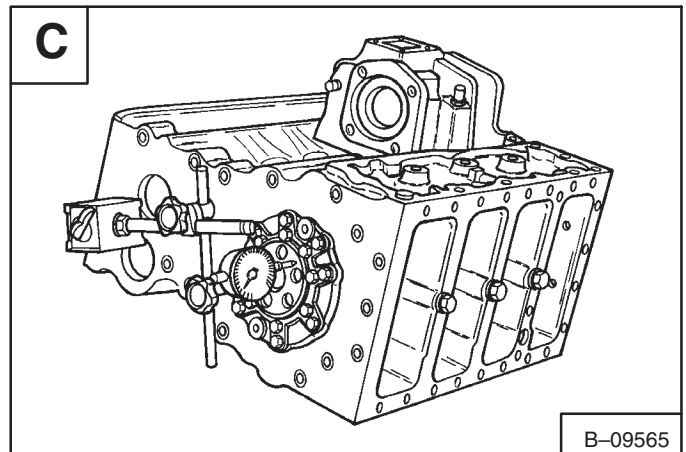
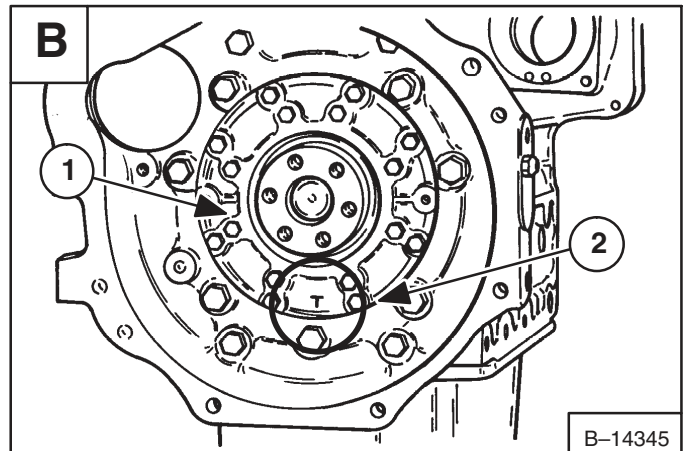
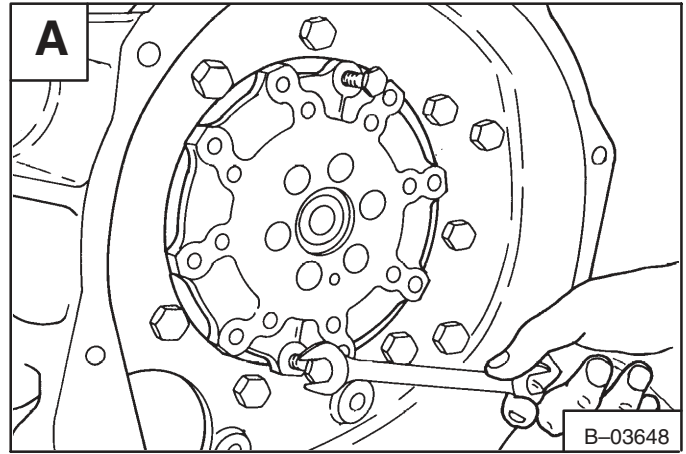

**BOBCAT INTERLOCK CONTROL SYSTEM (BICS™)
(S/N 509648900 & Above) (S/N 509617300 & Above)
Inspecting The BICS™ Controller
(Engine STOPPED – Key ON)**

1. Sit in the operator's seat. Turn key ON, lower the seat bar and disengage the parking brake pedal. Press the green *PRESS TO OPERATE* Button. All five BICS controller lights should be ON (Items 1, 2, 3, 4 & 5) [A].
2. Engage the parking brake pedal and raise the seat bar fully. System Activated (Item 1), Seat Bar (Item 2), Valve (Item 3) and Traction lights (Item 4) [A] should be OFF.

NOTE: Record what lights are blinking (if any) and number of blinks. Refer to Page 8–4.

3. Exit the loader and press Traction Lock Override button. Traction light (Item 4) [A] should be ON. Press override button again and Traction light (Item 4) [A] should be OFF.

Inspecting Deactivation Of The Auxiliary Hydraulics System (Engine STOPPED – Key ON)

4. Sit in the operator's seat. Lower the Seat Bar. Press the green *PRESS TO OPERATE* Button. Press the auxiliary hydraulics switch. The auxiliary switch light will come ON. Raise the Seat Bar. The light should be OFF.

Inspecting The Seat Bar Sensor (Engine RUNNING)

5. Sit in the operator's seat. Lower the seat bar. Engage the parking brake pedal. Fasten the seat belt.
6. Start the engine and operate at low idle. Press the green *PRESS TO OPERATE* Button. While raising the lift arms, raise the Seat Bar fully. The lift arms should stop. Repeat using the tilt function.

Inspecting The Traction Lock (Engine RUNNING)

7. Fasten the seat belt, disengage the parking brake pedal, press the green *PRESS TO OPERATE* Button and raise the Seat Bar fully. Move the steering levers slowly forward and backward. The Traction lock should be engaged. Lower the Seat Bar. Press the green *PRESS TO OPERATE* Button.
8. Engage the parking brake pedal and move the steering levers slowly forward and backward. The Traction lock should be engaged.

Inspecting The Lift Arm By-Pass Control

9. Raise the lift arms 6 feet (2 meters) off the ground. Stop the engine.

Turn the lift arm by-pass control knob clockwise 1/4 turn. Then pull up and hold the lift arm by-pass control knob until the lift arms slowly lower.

Additional Inspection For Loaders With Advanced Hand Controls

10. Sit in the operator's seat and fasten the Seat Belt. Lower the Seat Bar, start the engine and press the green *PRESS TO OPERATE* Button.
11. Raise the lift arms about 6 feet (2 meters) off the ground.
12. Turn the key OFF and wait for the engine to come to a complete stop.
13. Turn the key ON. Press the green *PRESS TO OPERATE* Button, move the left hand control toward the operator. The lift arms should not tower.
14. Move the right hand control away from the operator. The bucket (or attachment) should not tilt forward.

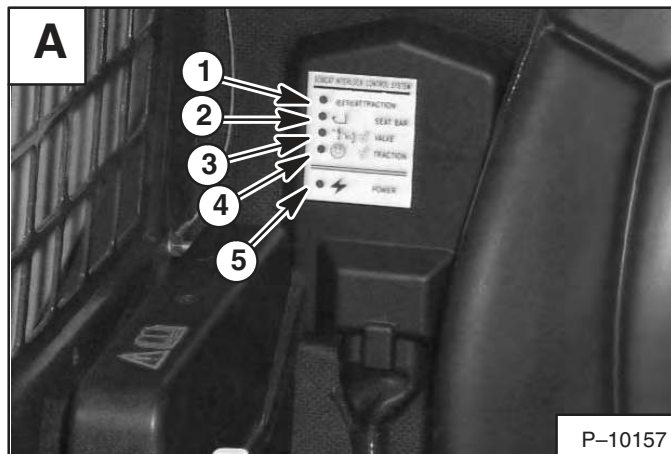

P-10157

WARNING

AVOID INJURY OR DEATH

The Bobcat Interlock Control System (BICS) must deactivate the lift, tilt and traction drive functions. If it does not, contact your dealer for service. **DO NOT** modify the system.

W-2151-0394

SEAT SENSOR (Cont'd)

Removal And Installation

Raise the loader operator cab. (See Page 1-1.)

Locate the seat sensor (Item 1) [A] beneath the operator cab.

Remove the sensor connector (Item 1) [B] from the holder and disconnect from the harness.

Remove the magnet collar mounting bolt (Item 2) [B] and washer (Item 1) [C].

Installation: Tighten the bolt to 180–200 in.-lbs. (21–23 Nm) torque.

IMPORTANT

DO NOT overtighten the magnet mounting bolt to prevent damage to the magnet.

I-2089-1095

Remove the magnet (Item 2) [C] from the sensor (Item 3) [B].

Installation: If the magnet collar (Item 2) [C] is tapered, install the tapered end to the seat. If the magnet collar (Item 2) [C] is not tapered, install as shown [C].

Remove the sensor mounting bolt (Item 4) [B] and nut.

Installation: Tighten the nut and bolt (Item 4) [B] until light pressure is applied to the sensor (Item 3) [B].

IMPORTANT

Be careful to not overtighten the sensor mounting bolt and nut to prevent breakage of the sensor.

I-2088-1095

Remove the sensor (Item 3) [C].

NOTE: Be sure not to lose the magnet collar alignment pin (Item 4) [C] which is located in the sensor (Item 3) [C] when removing the sensor.

Remove the threaded bushing (Item 5) [C] from the seat track mounting bolt (Item 1) [D].

Inspect all parts for damage and wear and replace if necessary.

Reverse the removal procedure to install the seat sensor

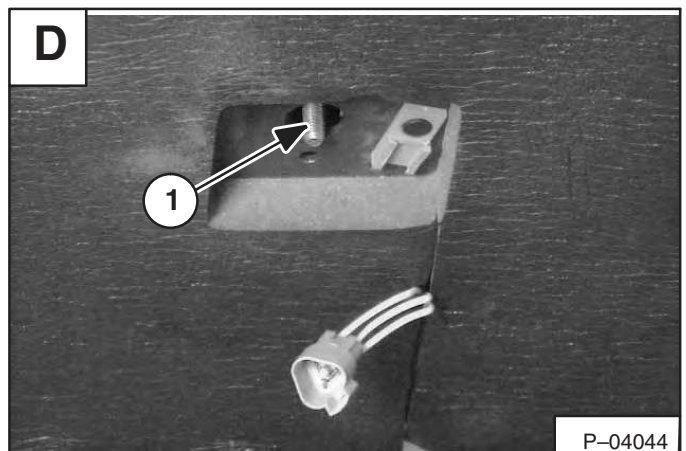
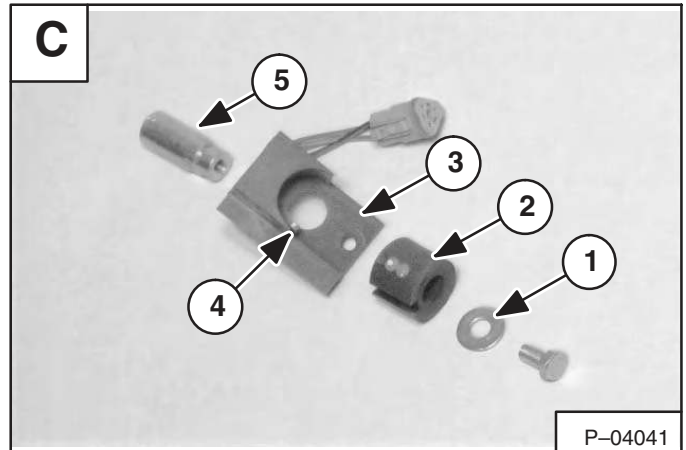
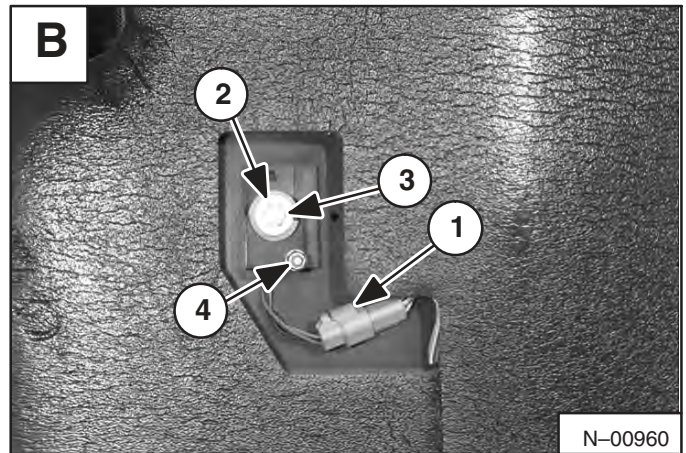
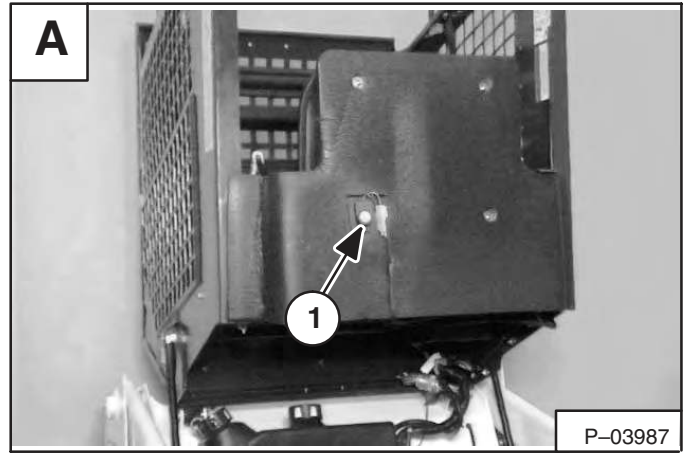

MONITOR SERVICE CODES

The following list references the defect codes that are transmitted to the instrument panel display which can occur. Some service procedures for correcting the problems can be found in this manual and other procedures must be performed ONLY BY QUALIFIED BOBCAT SERVICE PERSONNEL.



WARNING

Instructions are necessary before operating or servicing machine. Read and understand the Operation & Maintenance Manual, Handbook and signs (decals) on machine. Follow warnings and instructions in the manuals when making repairs, adjustments or servicing. Check for correct function after adjustments, repairs or service. Untrained operators and failure to follow instructions can cause injury or death.

W-2003-0199

Service Codes

SERVICE CODES		
SUBJECT	DISPLAY READS	CONDITION
Engine Coolant Level 	ECL 1	SHUTDOWN, No Coolant
Engine Coolant Temp. 	EC-1.1	SHUTDOWN, Engine Temperature
	EC-2.1	WARNING, Engine Temperature
	EC 3	Wiring Not Connected
	EC 4	Wiring Shorted
	EC 5	High Sensor Voltage
	EC 7	Sensor Out Of Range
Engine Oil Pressure 	EP 1	SHUTDOWN, Pressure
	EP 2	WARNING, Pressure
	EP 3	Wiring Not Connected
	EP 4	Wiring Shorted
	EP 5	High Sensor Voltage
	EP 7	Sensor Out Of Range
Engine Speed 	ES 1	SHUTDOWN, Engine Speed Too High
	ES-2.1	WARNING, Engine Speed Slightly High
	ES-6	Sensor No Signal
	ES-7	Sensor Out Of Range
Air Filter 	AF 2	WARNING, Restriction Too High
	AF 6	Sensor No Signal
Battery 	b-2.1	WARNING, Bad Battery
	b-2.2	WARNING, Battery Voltage
Fuel Level 	FUEL2	WARNING, Low Level
	FUEL3	Wiring Not Connected
	FUEL4	Wiring Shorted
	FUEL5	High Sensor Voltage
	FUEL7	Sensor Out Of Range

ENGINE SPECIFICATIONS

All dimensions are given in inches. Respective metric dimensions are given in millimeters enclosed by parentheses.

Fuel Injection Nozzles

Opening Pressure	1990–2133 PSI (13721–14707 kPa)
Fuel Tightness Nozzle Seat	Dry.Nozzle at 1849 PSI (12749 kPa)

Fuel Injection Pump

Fuel Tightness Plunger	10 sec: initial pressure 2133–1990 PSI (14707–13721 kPa)
Limit Permitted	5 seconds
Injection Timing	17–19 degrees B.T.D.C.
High Idle	2950–3050 RPM
Low Idle	1125–1175 RPM
Cylinder Bore	
I.D. of Bore	3.4252–3.4261 (87,0–87,022)
Allowable Limit	+0.006 (+0,15)

Cylinder Head

Cylinder Head Surface Distortion	0.002 (0,05) Max.
Thickness of Gasket (Used)	0.0453–0.0492 (1,15–1,25)
(New)	0.0512–0.0551 (1,3–1,4)
Top Clearance (Piston to Head)	0.0217–0.0276 (0,55–0,70)
Compression	412–469 PSI (2840–3234 kPa)
Allowable Limit	.327 PSI (2255 kPa)
Difference Between Cylinders	10%

Valves

Valve Seat Width	0.0835 (2,12)
Valve Seat Angle	Intake 30 degrees exhaust 45 degrees
O.D. of Valve Stems	0.3134–0.3142 (7,96–7,98)
I.D. of Valve Guides	0.3156–0.3161 (8,016–8,03)
Clearance Between Valve Stem & Guide	0.0016–0.0026 (0,04–0,07)
Allowable Limit	0.0039 (0,1)
Valve Clearance (Cold)	0.007–0.0087 (0,18–0,22)
Valve Recessing (Protrusion)	0.002 (0,05)
(Recess)	0.06 (0,15)

Valve Springs

Free Length	1.64–1.66 (41,7–42,2)
Allowable Limit	1.62 (41,2)
Fitted Length	1.378 (35,0)
Compress to Fitted Length	26.4 lbs. (117,6 N)
Allowable Limit	22.5 lbs. (100,0 N)
Inclination Allowable Limit	0.006 (0,15)

Valve Timing

Intake Valve (Open)	12 degrees B.T.D.C.
(Close)	36 degrees A.T.D.C.
Exhaust Valve (Open)	60 degrees B.T.D.C.
(Close)	12 degrees A.T.D.C.

Rocker Arms

O.D. of Rocker Arm Shaft	0.5501–0.5506 (13,97–13,99)
I.D. of Rocker Arm Bushings	0.5513–0.5529 (14,0–14,04)
Clearance Between Rocker Arm & Bushing	0.0007–0.0026 (0,02–0,06)
Allowable Limit	0.006(0,15)

TORQUE SPECIFICATIONS FOR LOADER

Specifications

Item	Ft.-Lbs.	Nm
Air Cleaner Mounting Bolts	25–28	34–38
Alternator Pulley Nut	50	68
Axle Hub Mounting Bolt	575–625	780–848
Axle Sprocket Bolt	220–245	298–332
Bob-Tach Pivot Pin Bolts	175–190	240–255
Bob-Tach Lever Pivot Bolt	25–28	34–38
Brake Block Mounting Bolts	65–70	88–95
Brake Lever Bolt	65–70	88–95
Brake Pad Mounting Bolts	65–70	88–95
Camshaft Retainer Plate Bolts	17–20	23–27
Centering Spring Bolt	25–28	34–38
Chaincase to Main Frame Bolts & Nuts	90–100	122–136
Connecting Rod Bolts:		
W/O Flange	27–30	37–41
W/Flange	33–36	45–49
Control Pedal Linkage Bolts	21–25	28–34
Control Valve Mounting Bolts & Nuts	15–16	20–22
Crankshaft Pulley Nut	101–116	137–157
Cylinder Head Bolts	67–72	91–98
Flywheel Bolts	83–90	113–122
Front Panel Bolts	16–20	22–27
Fuel Camshaft Retainer Plate Bolts	5–6	6,8–8,1
Glow Plug	15–18	20–24
Hydraulic Reservoir Strap Bolts	16–20	22–27
Hydraulic Filter Housing Mounting Bolts	25	34
Hydrostatic Motor Mounting Bolts	90–100	122–136
Hydrostatic Pump Mounting Bolts	65–70	88–95
Hydrostatic Pump Pulley Nut	175–200	237–271
Idler Gear Shaft Bolts	17–20	23–27
Injection Pump Mounting Bolts & Nuts	17–20	23–27
Injection Nozzles	36–51	46–69
Injector Nozzle Body	43–58	59–79
Main Bearing Case Bolt	51–54	69–73
Main Bearing Case Half Bolts	34–38	46–52
Main Relief Valve	35–40	47–54
Motor Carrier Mounting Bolts	125–140	170–190
Operator Cab Fastening Nuts (Front)	40–50	54–68
Operator Cab Pivot Bolts & Nuts	25–35	34–47
Pedal Lock Linkage to Main Frame Bolts	7–8	9,5–10,8
Pedal Lock Linkage Tab Bolt	25	34
Pintle Arm Bolt	40–50	54–68
Pintle Arm Lobe Bolt	25–28	34–38
Pintle Bar Bolts	28	38
Pivot Pins Lock Bolt & Nut	18–20	24–27
Rear Bearing Case Cover Bolts	13–15	18–20
Seat Belt Fastening Bolts	40–45	54–61
Seat Mounting Bolts	9–11	12,2–15
Seat Bar Pivot Bolts	25–28	34–38
Steering Linkage Bolts	23	31
Steering Linkage Lock Nuts	23	31
Timing Gearcase Cover Bolts	13–17	18–23
Wheel Nuts	105–115	142–156

ADVANCED HAND CONTROLS HARNESS - 6716963

B1CS CONTROLLER HARNESS - 6712134

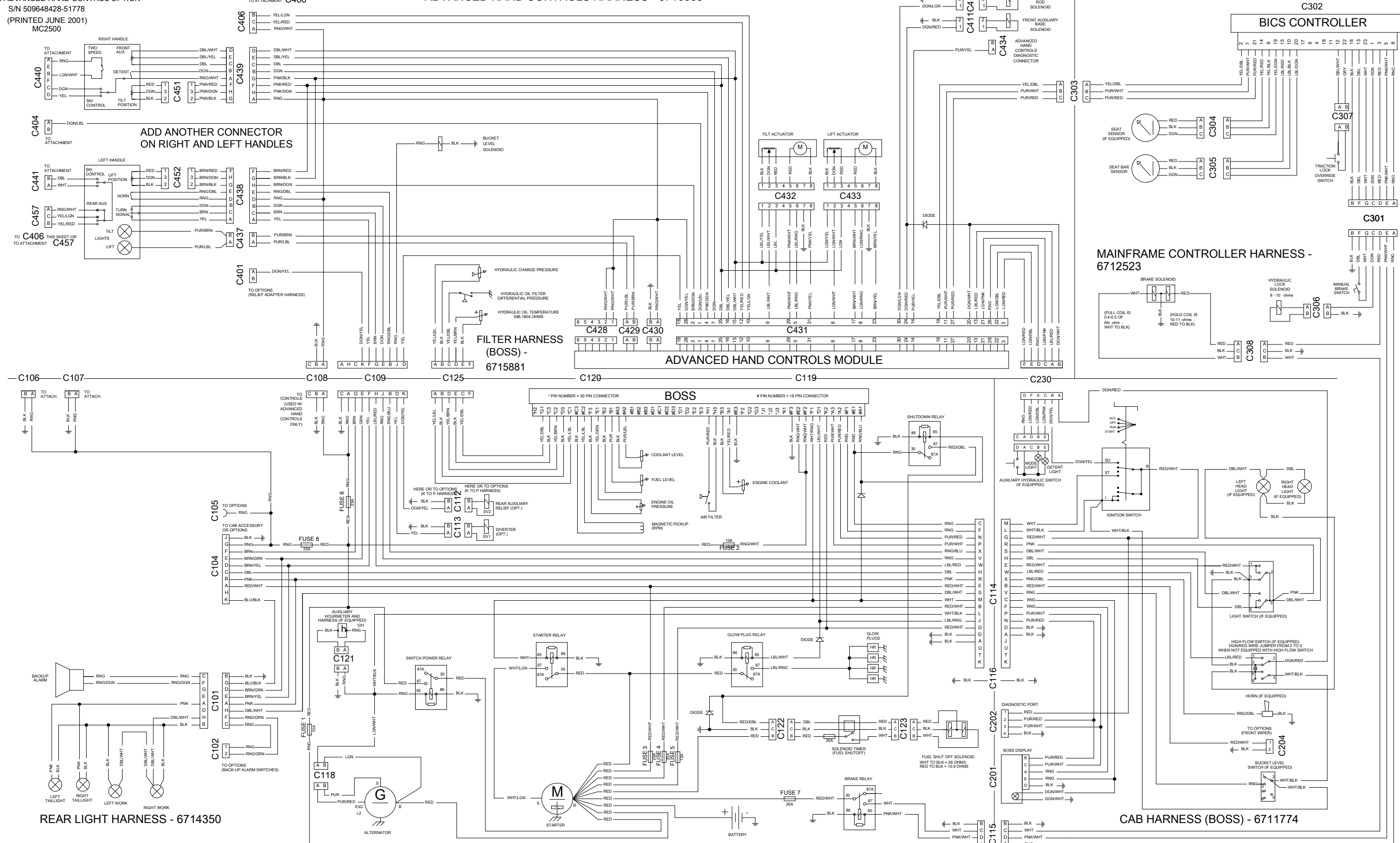

FUSE	BOSS	ENGINE	FUSE
FUSE 1	10A	10A	FUSE 5
FUSE 2	10A	25A AUX/HC	FUSE 6
FUSE 3	25A LIGHT	25A BRAKE	FUSE 7
FUSE 4	25A ACCESSORY	25A ACCESSORY	FUSE 8

FUSE BLOCK

WIRES CONNECT BY LETTER ACROSS CONNECTORS

SOME CONNECTOR BODIES NOT SHOWN FOR DRAWING CLARITY

RED = RED
 RNG = ORANGE
 BLK = BLACK
 LBL = LIGHT BLUE
 DBL = DARK BLUE
 LGN = LIGHT GREEN
 DGN = DARK GREEN
 YEL = YELLOW
 PNK = PINK
 WHT = WHITE
 BRN = BROWN
 TAN = TAN
 PUR = PURPLE
 GRN = GREY

ACTUATOR VOLTAGE TEST (Cont'd)

Procedure (Cont'd)

Diagnosis Results For Tilt Actuator (top) Sensor Supply Voltage Test;

If the sensor supply voltage is 4.3 ± 0.1 volts (5.0 ± 0.1 volts Hall-Effect), continue on and check the signal voltage.

If the sensor supply voltage is less than 4.3 ± 0.1 volts (5.0 ± 0.1 volts*) or 0 volts, check the PWM fuse, check for shorts or opens in the wiring harness. If there are no apparent shorts or opens change the AHC/PWM controller. (See Page 10-13.)

If the sensor supply voltage is more than 4.3 ± 0.1 volts (5.0 ± 0.1 volts*) check for a short of the power wires in the wiring harness. If there are no apparent shorts change the AHC/PWM controller. (See Page 10-15.)

Diagnosis Results For Tilt Actuator Signal Voltage Test;

If the signal voltage is in the range of 1.55 to 1.85 volts (1.80 ± 2.15 volts*), the system is functioning properly. The nominal voltage reading is 1.72 volts (2.0 volts*).

If the signal voltage is not in the range of 1.55 to 1.85 volts (1.80 ± 2.15 volts*) check the hydraulic control valve spools for a centering problem or replace the actuators. (See Page 10-29.)

Handle Out (Toward Side Screen):

1. Stop engine. Raise operator cab.
2. Connect the remote start switch (MEL1429A) to the loader.
3. Turn key to ON position with engine OFF to get a code indication from the indicator lights on the left control handle.
4. Check the sensor supply voltage. (See Page 10-8.)
5. Check the system to make sure it is functional, with no blinking indicator lights.
6. Move right AHC handle toward the side screen to full stroke. Hold in position and take a voltage reading. The voltage reading must be 0.13 volts (0.15 volts*) or greater. If the voltage reading is less than 0.13 volts (0.15 volts*), replace the actuator. (See Page 10-29.) While holding the handle toward the side screen turn the key to OFF position and wait five seconds..
7. Continue to hold the handle toward the side screen and turn the key to the ON position. Take a voltage reading. (You will have a one blink alarm on the right indicator light.) The voltage reading should be between 1.55 to 1.85 volts (1.80 ± 2.15 volts*). If the voltage is above 1.85 volts (2.15 volts*), repeat steps 5 thru 7, if the voltage is still above 1.85 volts (2.15 volts*) change the actuator. If the voltage is below 1.55 volts (1.80 volts*) complete the following tests: (See Step 11 Below; Tests **a** & **b**.)

Handle In (Toward Center Of Cab):

8. Turn the key to OFF position and wait five seconds, then turn key to ON position. Check the system to make sure it is functional, with no blinking indicator lights.
9. Move right AHC handle toward the center of the cab to full stroke. Hold in position and take a voltage reading. The voltage reading must be 3.2 volts (3.72 volts *) or less. If the voltage reading is more than 3.2 volts (3.72 volts *), check for shorts in the electrical connections, or replace the actuator. (See Page 10-29.)
10. While the handle is held toward the center of the cab, turn the key to OFF position and wait five seconds.
11. Continue to hold the handle toward the center of the cab and turn the key to the ON position and take a voltage reading. (You will have a one blink alarm on the right indicator light.) The voltage reading should be between 1.55 to 1.85 volts (1.80 ± 2.15 volts*). If the voltage is below 1.55 volts (1.80 volts*), repeat steps 8 thru 11 if the voltage is still below 1.55 volts (1.80 volts*) change the actuator. If the voltage is above 1.85 volts (2.15 volts*) complete the following tests:
 - a. Remove the pin from the actuator to the control spool. Watch the spool, if the spool continues to move toward neutral after the pin is removed, replace the actuator. Also check the mounting hardware on the actuators and control valve for wear and correct torque.
 - b. If the spool does not move, check the control valve for a sticky spool or sticky centering mechanism. Also check the mounting hardware on the actuators and control valve for wear and correct torque.

* Hall-Effect (Identified by yellow push button float switch on left-hand handle.)

CONTROL HANDLE (ADVANCED HAND CONTROL) (AHC)

Control Handle Unit Removal And Installation

To remove the handle control unit, slide the rubber handle cover (Item 1) [A] up the handle.

Remove the two mounting bolts (Item 2) [A] from the control cover.

Remove the control cover.

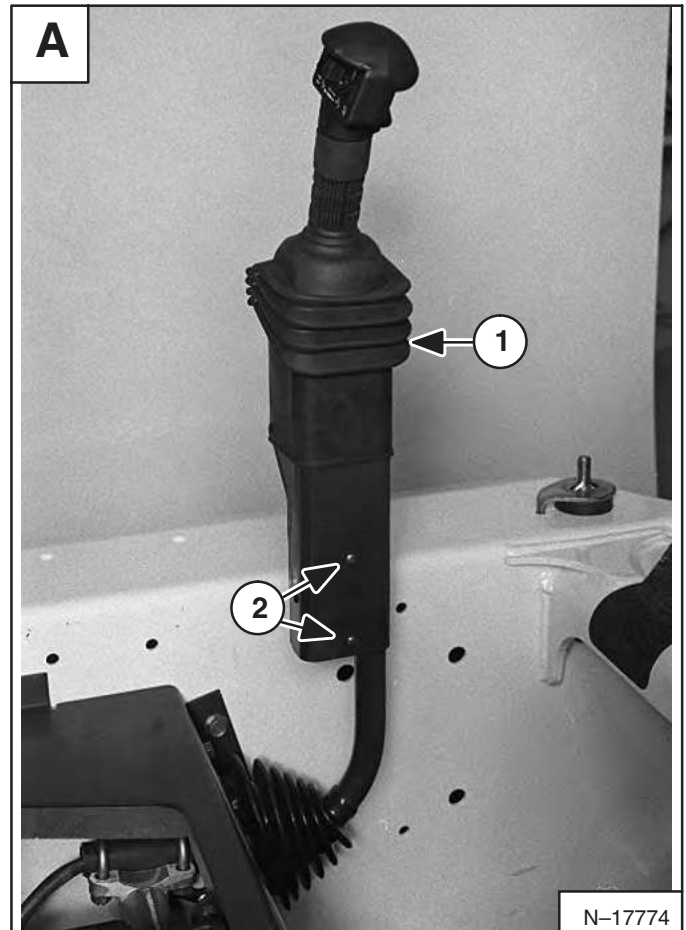

Disconnect the loader control harness (Item 1) [B] from the handle control harness.

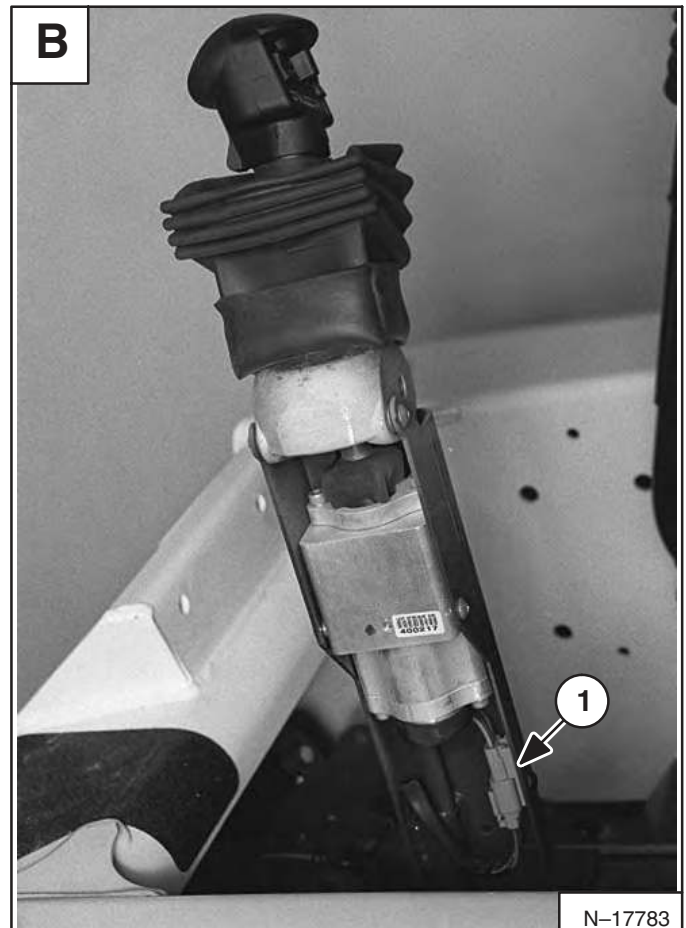

CONTROL HANDLE (ADVANCED HAND CONTROL) (AHC) (Cont'd)

Actuators Removal And Installation

NOTE: For correction installation of the actuator , mark all the wire connections (Item 1) [A] before disconnecting them.

Remove the steering levers/control panel assembly(See Page 3-1.)

Disconnect the wiring harness connectors (Item 1) [A] from the actuator connectors.

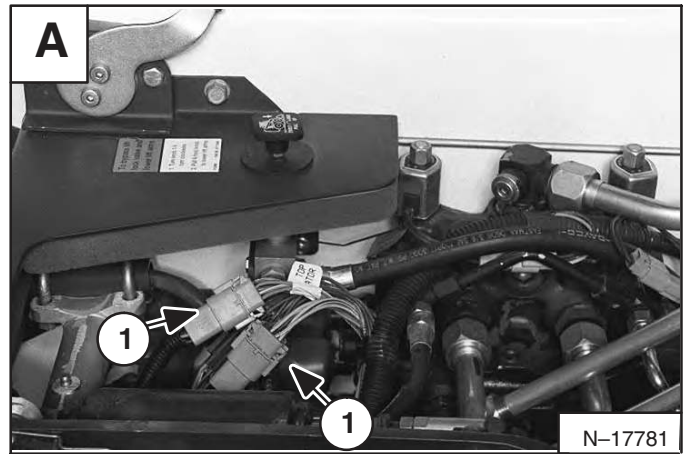

Remove the pins (Item 1) [B] from the actuator couplers.

Remove the two mounting bolts (Item 2) [B] from the control valve mounting plate and actuator mounting block.

Installation: Tighten the mounting bolts to 30 ft.-lbs. (40,7 Nm) torque.

Remove the actuators and mounting block assembly.

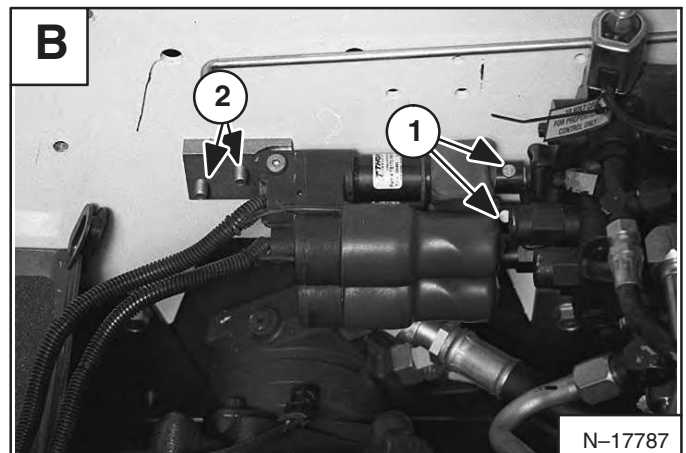

CONTROL HANDLE (ADVANCED HAND CONTROL) (AHC) W/PUSH BUTTON FLOAT (Cont'd)

Switch Handle Removal And Installation (Cont'd)

Roll the pistol grip handle cover (Item 1) [A] down.

Using a small screwdriver, lift the handle tabs (Item 2) [A] and slightly rotate the switch handle.

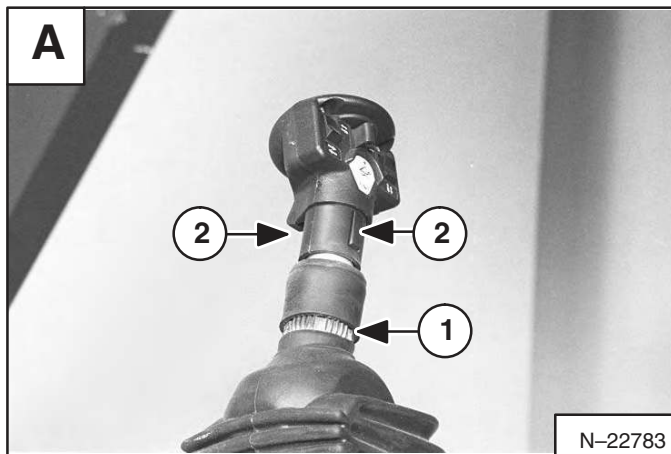

Pull the switch handle and wiring harness assembly (Item 1) [B] from the control lever.

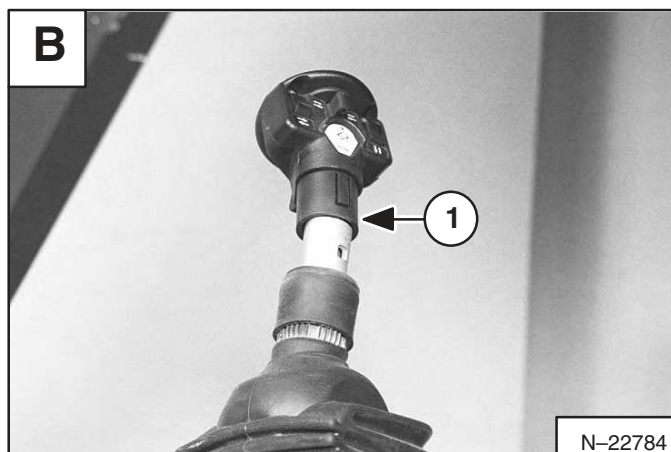

Installation: When installing the switch handle and wiring harness assembly into the control handle, route the harness (Item 1) [C] to assure proper return of the control handle to neutral position.

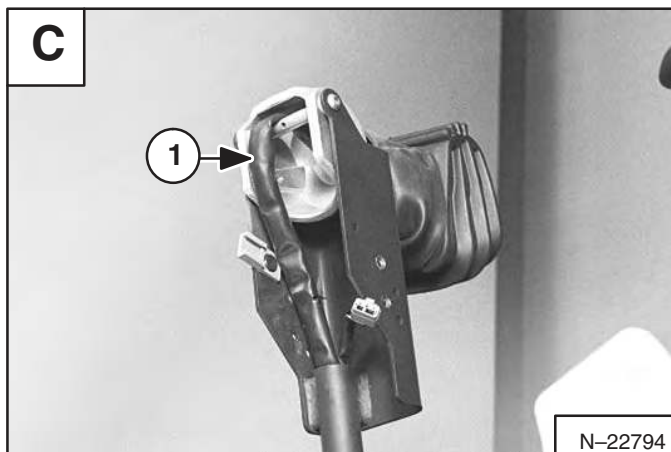

HYDRAULIC CONTROL VALVE

Removal And Installation

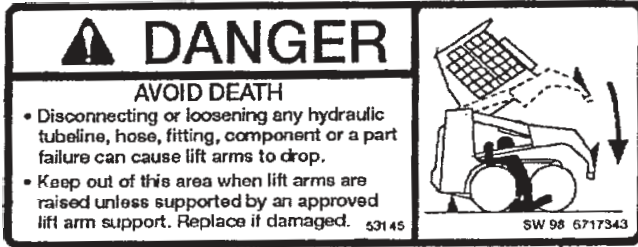

Raise the lift arms and install an approved lift arm support device. (See Page 1-1.)



Stop the engine. Use the lift lock valve knob to release the hydraulic pressure. Raise the seat bar.

Lift and block the loader. (See Page 1-1.)

Raise the operator cab. (See Page 1-1.)

Remove the actuators. (See Page 10-29.)

Clean the area around the control valve.

Mark all tubelines for correct installation.

Disconnect the wire harness connectors (Item 1 [A]) from the auxiliary solenoid connectors.

Disconnect the harness connector (Item 2) [A] from the BICS valve solenoid connector.

Installation: Install a never modify strap around the connector (Item 2) [A].

Disconnect the drain hoses (Item 3) [A] from the main control valve.

Disconnect the outlet tubeline (Item 1) [B] from the control valve.

Disconnect both tubelines (Item 2) [B] from the auxiliary section of the control valve.

Disconnect the hose (Item 1) [C] from the lift arm by-pass control valve.

Disconnect the tilt tubelines (Item 2) [C].

Disconnect the lift tubelines (Item 3) [C].

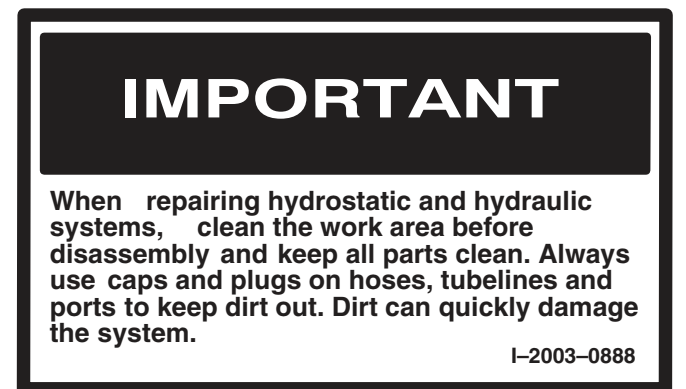
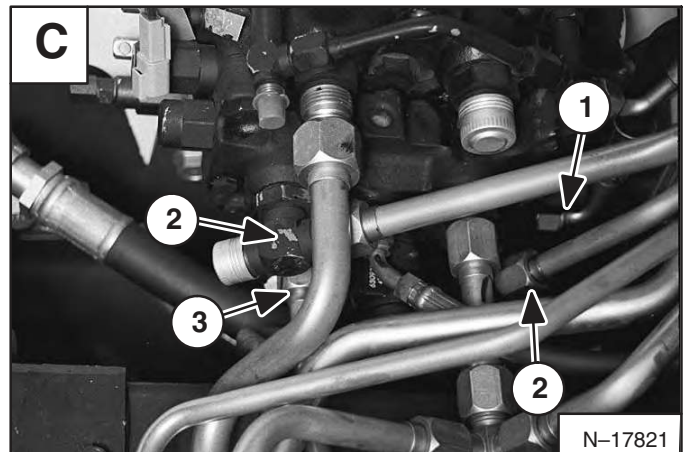
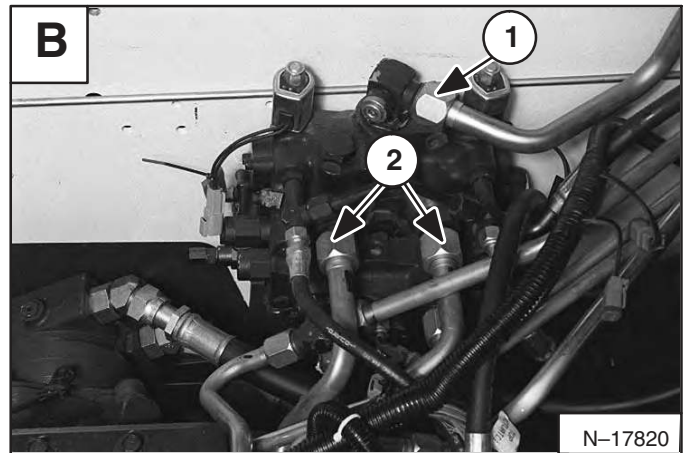
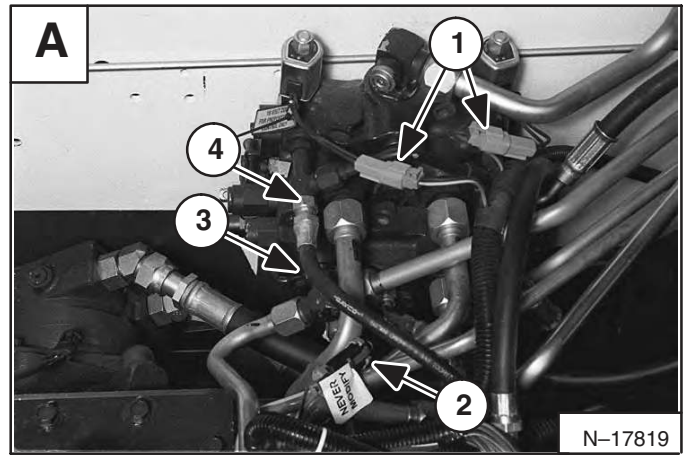

HYDRAULIC CONTROL VALVE (Cont'd)

Lift And Tilt Spool (Cont'd)

Lift Spool Only: To remove the plastic plug from the lift spool:

Make a center point in the plug using a 1/16 inch drill.

Drill a hole all the way through the plug using a 7/64 inch tap drill.

Turn a 6–32 tap into the plug. Pull the tap and plug out of the spool. Be careful, do not break the tap.

Clean all the debris from the inside of the spool bore.

Installation: Slide the O–ring over the nipple on the plastic plug. Install the plastic plug in the spool. Install the bolt so that the end of the plug is about 0.60 inch (15,2 mm) from the end of the spool [A].

NOTE: During installation of the centering spring to the spool, make sure the adapter is centered in the washer hole (Item 1) [B]. If the adapter is not centered, it can cause the bolt to break during installation.

Inspection

Check the spools for wear or scratches.

Check that the spools are not loose in their bore.

Check that the centering springs are not broken.

Check that the load check valve seats are not worn.

Check the load check poppet for damage.

Check the rubber boots and retainers that they are not worn or damaged.

Replace all parts as needed.

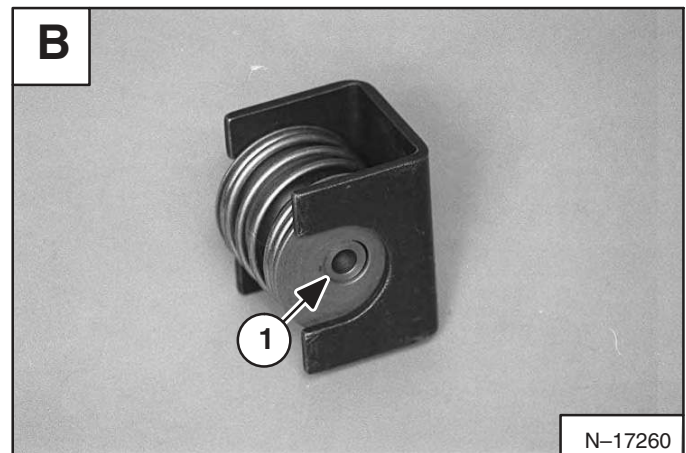
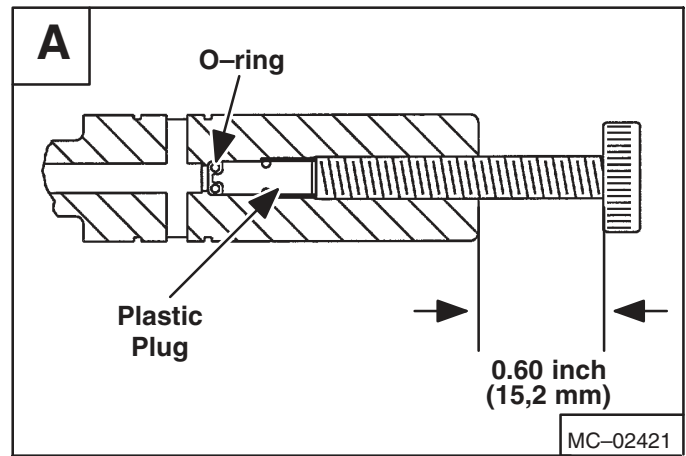

CLICK HERE TO **DOWNLOAD** THE COMPLETE MANUAL

- Thank you very much for reading the preview of the manual.
- You can download the complete manual from: www.heydownloads.com by clicking the link below



- Please note: If there is no response to **CLICKING** the link, please download this PDF first and then click on it.

CLICK HERE TO **DOWNLOAD** THE COMPLETE MANUAL