

**753**



**Bobcat®**

# Service Manual

**G Series**

**(S/N 515830001 & Above)**

**(S/N 516220001 & Above)**

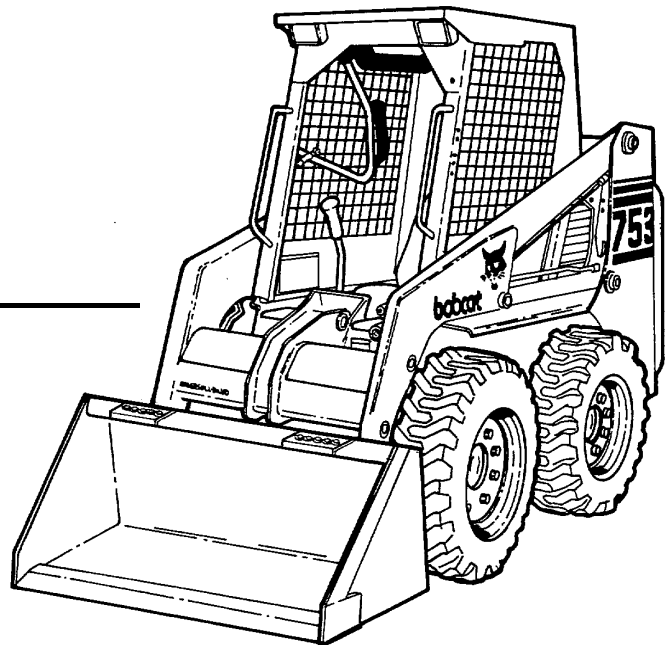

**EQUIPPED WITH  
BOBCAT INTERLOCK  
CONTROL SYSTEM (BICS™)**

6900976 (2-06)

**IR** Ingersoll Rand  
Compact Vehicle Technologies

Printed in U.S.A.

© Bobcat Company 2006

CLICK HERE TO **DOWNLOAD** THE COMPLETE MANUAL

- Thank you very much for reading the preview of the manual.
- You can download the complete manual from: [www.heydownloads.com](http://www.heydownloads.com) by clicking the link below



- Please note: If there is no response to CLICKING the link, please download this PDF first and then click on it.

CLICK HERE TO **DOWNLOAD** THE COMPLETE MANUAL

## SAFETY INSTRUCTIONS



### Safety Alert Symbol

This symbol with a warning statement means:  
“Warning, be alert! Your safety is involved!”  
Carefully read the message that follows.



## WARNING

Instructions are necessary before operating or servicing machine. Read and understand the Operation & Maintenance Manual, Operator's Handbook and signs (decals) on machine. Follow warnings and instructions in the manuals when making repairs, adjustments or servicing. Check for correct function after adjustments, repairs or service. Untrained operators and failure to follow instructions can cause injury or death.

W-2003-0903



## WARNING

Warnings on the machine and in the manuals are for your safety. Failure to obey warnings can cause injury or death.

W-2044-1285

## IMPORTANT

This notice identifies procedures which must be followed to avoid damage to the machine.

I-2019-0284

The following publications provide information on the safe use and maintenance of the Bobcat machine and attachments:

- The Delivery Report is used to assure that complete instructions have been given to the new owner and that the machine is in safe operating condition.
- The Operation & Maintenance Manual delivered with the machine or attachment contains operating information as well as routine maintenance and service procedures. It is a part of the machine and can be stored in a container provided on the machine. Replacement Operation & Maintenance Manuals can be ordered from your Bobcat dealer.
- Machine signs (decals) instruct on the safe operation and care of your Bobcat machine or attachment. The signs and their locations are shown in the Operation & Maintenance Manual. Replacement signs are available from your Bobcat dealer.
- An Operator's Handbook fastened to the operator cab. It's brief instructions are convenient to the operator. The handbook is available from your dealer in an English edition or one of many other languages. See your Bobcat dealer for more information on translated versions.
- The AEM Safety Manual delivered with the machine gives general safety information.
- The Service Manual and Parts Manual are available from your dealer for use by mechanics to do shop-type service and repair work.
- The Skid-Steer Loader Operator Training Course is available through your local dealer or at [www.training.bobcat.com](http://www.training.bobcat.com) or [www.bobcat.com](http://www.bobcat.com). This course is intended to provide rules and practices of correct operation of the Skid-Steer Loader. The course is available in English and Spanish versions.
- Service Safety Training Courses are available from your Bobcat dealer or at [www.training.bobcat.com](http://www.training.bobcat.com) or [www.bobcat.com](http://www.bobcat.com). They provide information for safe and correct service procedures.
- The Skid-Steer Loader Safety Video is available from your Bobcat dealer or at [www.training.bobcat.com](http://www.training.bobcat.com) or [www.bobcat.com](http://www.bobcat.com).

SI SSL-0206 SM

## LIFT ARM SUPPORT DEVICE

### Installing Lift Arm Support Device

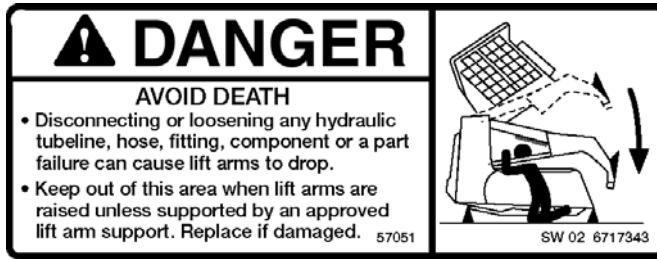

Never work on a machine with the lift arms up unless the lift arms are secured by an approved lift arm support device. Failure to use an approved lift arm support device can allow the lift arms or attachment to fall and cause injury or death.

W-2059-0598



Service lift arm support device if damaged or if parts are missing. Using a damaged lift arm support or with missing parts can cause lift arms to drop causing injury or death.

W-2271-1197

Figure 10-20-1

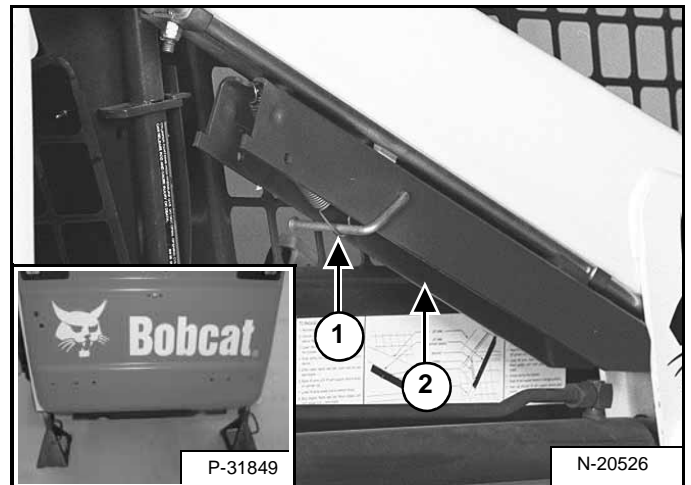

Put jackstands under the rear corners of the loader frame (Inset) [Figure 10-20-1].

Disconnect the spring from the lift arm support device retaining pin (Item 1). Support the lift arm support device (Item 2) [Figure 10-20-1] with your hand and remove the retaining pin.

Figure 10-20-2

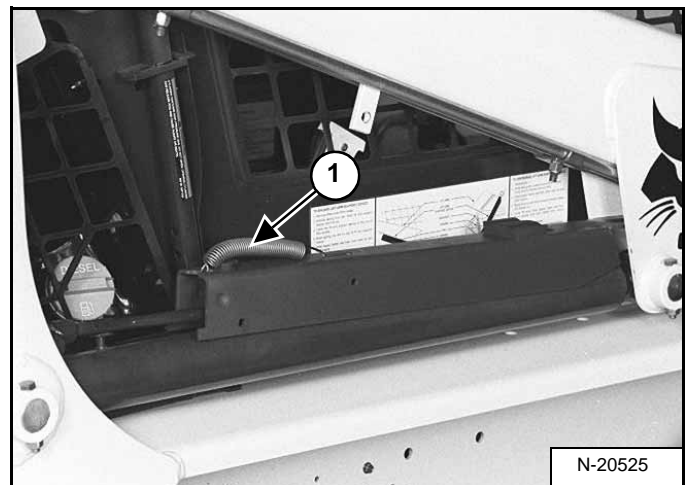

Lower the lift arm support device on top of the lift cylinder. Hook the free end of the spring (Item 1) [Figure 10-20-2] to the lift arm support device so there will be no interference with the support device engagement.

With the operator in the seat, seat belt fastened and seat bar lowered, start the engine.

## REMOTE START

### Procedure

Figure 10-60-1



The tool listed will be needed to do the following procedure:

MEL1563: Remote Start Tool Kit

The remote start (Item 1) [Figure 10-60-1] is required when the operator cab is in the raised position for service and the service technician needs to turn the key switch on or start the engine. Example: adjusting the steering linkage.

Figure 10-60-2

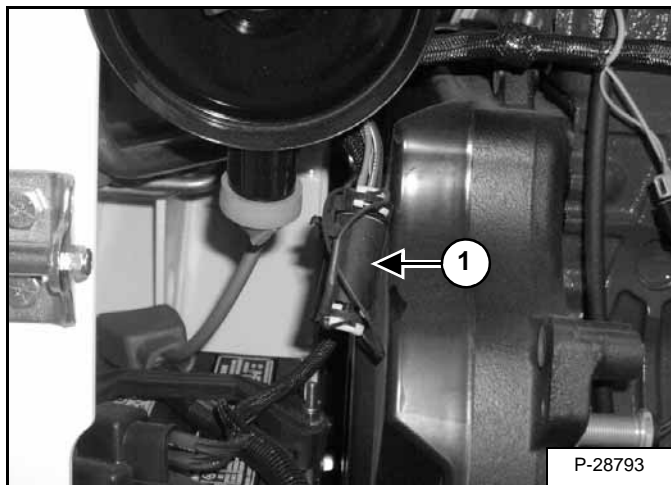
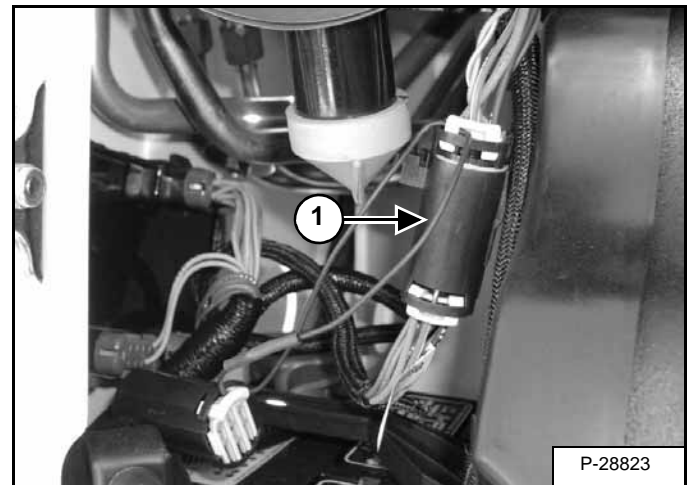

Figure 10-60-3



Lift and block the loader. (See LIFTING AND BLOCKING THE LOADER on Page 10-10-1.)

Raise the lift arms (if required by the procedure) and install an approved lift arm support device. (See Installing Lift Arm Support Device on Page 10-20-1.)

Raise the operator cab (if required by the procedure). (See Raising The Operator Cab on Page 10-30-1.)

Open the rear door of the loader.

Remove the plug (Item 1) [Figure 10-60-2] /or disconnect the attachment control harness (Item 1) [Figure 10-60-3] if connected.

## ENGINE COOLING SYSTEM

### **WARNING**

Wear safety glasses to prevent eye injury when any of the following conditions exist:

- When fluids are under pressure.
- Flying debris or loose material is present.
- Engine is running.
- Tools are being used.

W-2019-1285

Check the cooling system every day to prevent overheating, loss of performance or engine damage.

### Cleaning The Cooling System

Figure 10-90-1

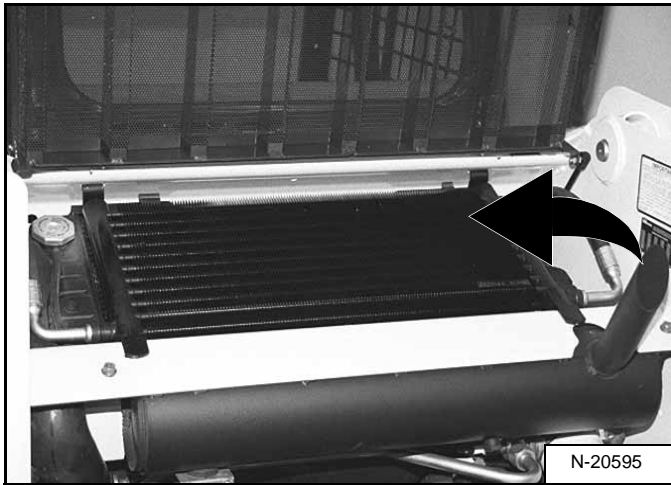

Open the rear door and raise the rear grill.

Use air pressure or water pressure to clean the top of the oil cooler [Figure 10-90-1].

### **WARNING**

Do not use your bare hands to remove debris from the oil cooler. Cooling fins are sharp and may cause injury.

W-2460-0303

Figure 10-90-2

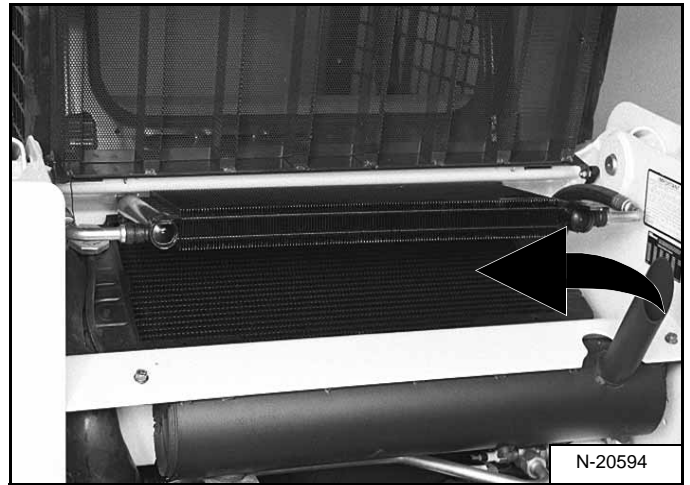

Raise the oil cooler. Clean the top of the radiator [Figure 10-90-2].

**NOTE:** Use low air pressure or low water pressure to clean the radiator or damage to the radiator fins may result.

Lower the oil cooler.

Check cooling system for leaks.

Lower the rear grill and close the rear door.

### Checking The Coolant Level

Figure 10-90-3

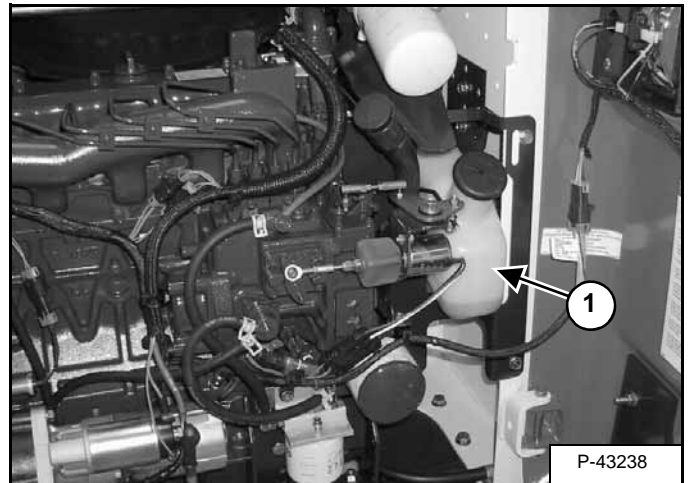

Open the rear door.

Remove the cover from the coolant recovery tank (Item 1) [Figure 10-90-3]. Check the coolant level. The coolant level must be between the MIN and MAX marks on the coolant recovery tank when the engine is cold.

Close the rear door before operating the loader.

## HYDRAULIC/HYDROSTATIC SYSTEM

### Checking And Adding Fluid

Figure 10-120-1

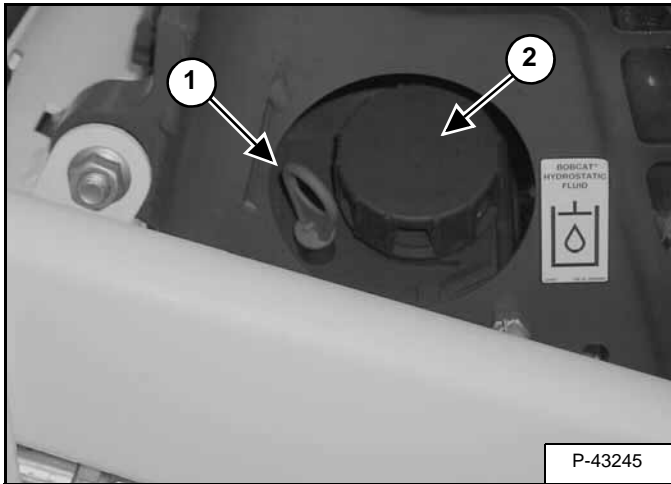

Use only recommended fluid in the hydraulic system. (See HYDRAULIC FLUID SPECIFICATIONS on Page SPEC-50-1.)

Stop the loader on a level surface,

Lower the lift arms and tilt the Bob-Tach fully back.

Stop the engine.

Remove the dipstick (Item 1) [Figure 10-120-1] and check the fluid level.

Remove the fill cap (Item 2) [Figure 10-120-1].

Figure 10-120-2

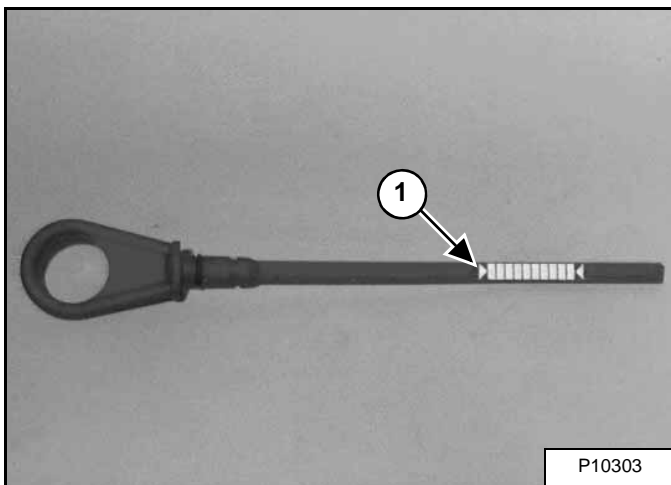

Add the correct fluid to the reservoir until the fluid level is between the marks on the dipstick (Item 1) [Figure 10-120-2]. Do not fill above the top mark on the dipstick

Figure 10-120-3

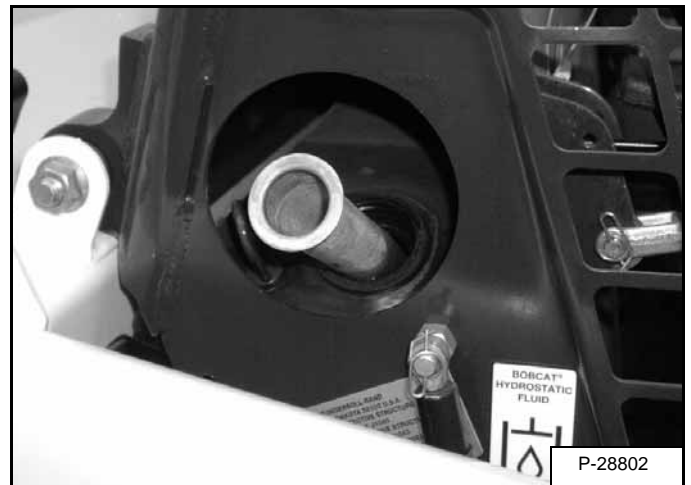

Remove the screen and clean with solvent as needed [Figure 10-120-3].

Install the fill cap.

### Replacing Hydraulic/Hydrostatic Filter

Figure 10-120-4

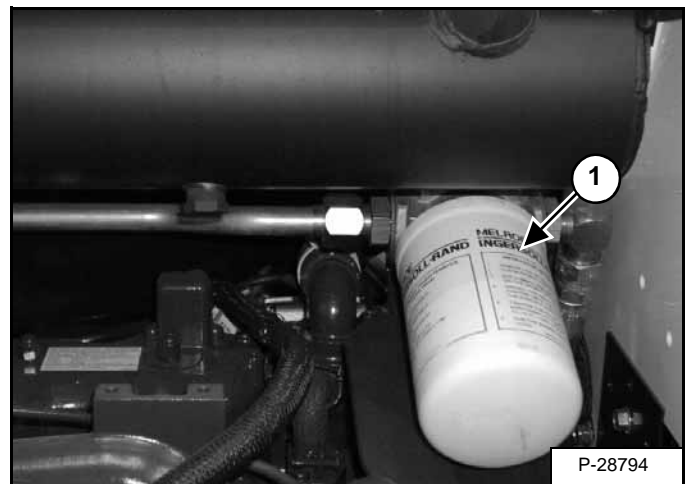

(See SERVICE SCHEDULE on Page 10-70-1.) for the correct service intervals.

Open the rear door.

Remove the filter element (Item 1) [Figure 10-120-4].

Clean the gasket sealing surface on the filter housing.

Put clean oil on the seal of the new filter element.

Install and hand tighten the filter element.

Close the rear door before operating the loader.

Start the engine, check for leaks and the proper fluid level in the reservoir.

# POWER BOB-TACH

## Inspection And Maintenance

Figure 10-151-1

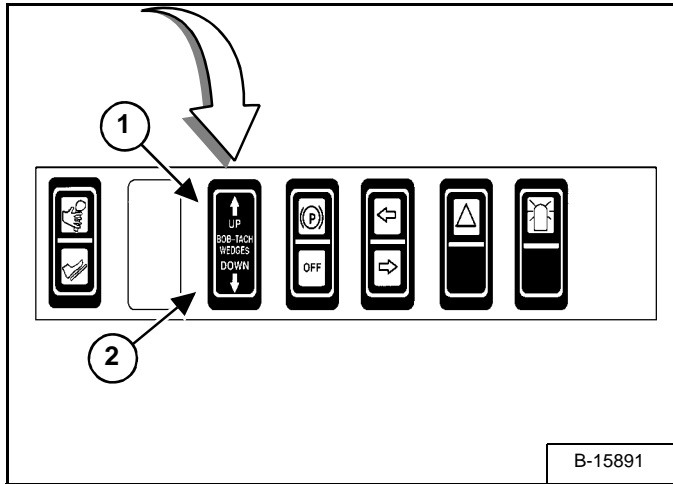
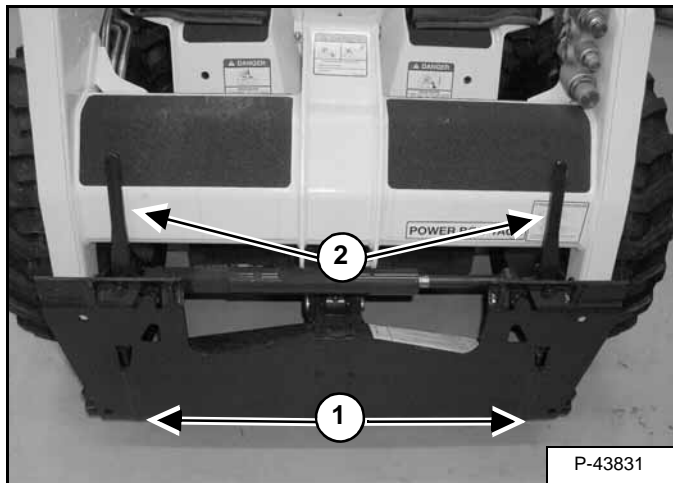
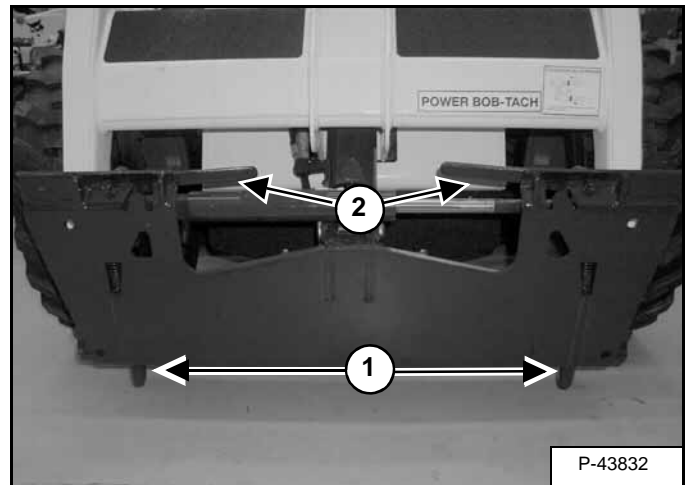

Figure 10-151-2



Push and hold the BOB-TACH “WEDGES UP” switch (Item 1) [Figure 10-151-1], until the wedges (Item 1) and levers (Item 2) [Figure 10-151-2] are fully raised.

Figure 10-151-3



Push and hold the BOB-TACH “WEDGES DOWN” switch (Item 2) [Figure 10-151-1], until the wedges (Item 1) and levers (Item 2) [Figure 10-151-3] are fully down.

The levers and wedges must move freely.



Bob-Tach wedges must extend through the holes in attachment. Levers must be fully down and locked. Failure to secure wedges can allow attachment to come off and cause injury or death.

W-2102-0588

## HYDRAULIC SYSTEM

## HYDRAULIC SYSTEM

BUCKET POSITION VALVE . . . . .	20-90-1
Disassembly And Assembly . . . . .	20-90-3
Removal And Installation . . . . .	20-90-2
Solenoid Removal And Installation . . . . .	20-90-1
Solenoid Testing . . . . .	20-90-1
CYLINDER (LIFT) . . . . .	20-20-1
Assembly . . . . .	20-20-5
Checking . . . . .	20-20-1
Disassembly . . . . .	20-20-4
Identification . . . . .	20-20-3
Removal And Installation . . . . .	20-20-2
CYLINDER (POWER BOB-TACH) . . . . .	20-22-1
Assembly . . . . .	20-22-5
Checking . . . . .	20-22-1
Disassembly . . . . .	20-22-4
Parts Identification . . . . .	20-22-3
Removal And Installation . . . . .	20-22-2
CYLINDER (TILT) . . . . .	20-21-1
Assembly . . . . .	20-21-6
Checking . . . . .	20-21-1
Disassembly . . . . .	20-21-5
Identification . . . . .	20-21-4
Removal And Installation . . . . .	20-21-1
Rod End Pivot Pin Bushing And Seal Replacement . . . . .	20-21-3
FRONT AUXILIARY HYDRAULIC COUPLER BLOCK . . . . .	20-121-1
Disassembly And Assembly . . . . .	20-121-1
Removal and Installation (S/N 515842310 & Above) . . . . .	20-121-1
FRONT AUXILIARY PRESSURE RELIEF BLOCK . . . . .	20-120-1
Disassembly And Assembly (S/N 515842309 and Below) . . . . .	20-120-2
Removal And Installation (S/N 515842309 and Below) . . . . .	20-120-1
Solenoid Inspection . . . . .	20-120-3
Solenoid Testing . . . . .	20-120-3

Continued On Next Page

# HYDRAULIC SYSTEM INFORMATION (CONT'D)

## Glossary Of Hydraulic/Hydrostatic Symbols (Cont'd)

### GLOSSARY OF HYDRAULIC/HYDROSTATIC SYMBOLS FOR LOADERS

SYMBOL DESCRIPTION

NON-RETURN VALVE, SHUTTLE VALVE: Valve which allows free flow in one direction only



NON-RETURN VALVE (Check Valve) - Used as Replenishing Valve, Load Check Valve or Anticavitation Valve - Opens if the Inlet pressure is higher than the Outlet pressure. Often contains internal spring which has NO significant pressure value



SPRING LOADED VALVE (Bypass Valve) - Opens if the Inlet pressure is greater than the Outlet pressure plus the spring pressure

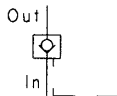

PILOT CONTROLLED NON-RETURN VALVE - It is possible to open the valve by pilot pressure

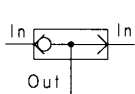

SHUTTLE VALVE - The Inlet port connected to the higher pressure is automatically connected to the Outlet port while the other Inlet port is closed

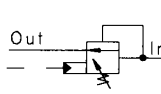

DUAL PRESSURE RELIEF VALVE - When the inlet pressure overcomes the opposing force of the spring, the valve opens permitting flow from the Outlet port. Pilot pressure provides a second pressure value.

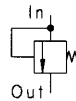

RELIEF VALVE - When the Inlet pressure overcomes the opposing force of the spring, the valve opens permitting flow from the Outlet port.

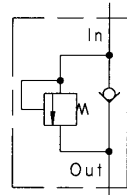

RELIEF/REPLENISHING VALVE or RELIEF/ANTICAVITATION VALVE - When the Inlet pressure overcomes the opposing force of the spring, the valve opens permitting flow from the Outlet port - Allows free flow in the opposite direction

DIRECTIONAL CONTROL VALVE: Valve providing for the opening (fully or restricted) or the closing of one or more flow paths (represented by several squares)



TWO PORTS and CLOSED FLOW PATHS



SOLENOID ACTIVATED DIRECTIONAL CONTROL VALVE (Two Position) - controlled by an electric solenoid (with return spring)

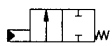

PILOT ACTIVATED DIRECTIONAL CONTROL VALVE (Two Position) - controlled by pressure (with return spring)

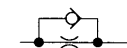

ONE WAY RESTRICTOR VALVE (Non-Return Valve with Restriction) - Unit allowing free flow in one direction but restricted flow in the other direction



TOW VALVE - Normally in closed position

## CYLINDER (LIFT) (CONT'D)

### Assembly (Cont'd)

Figure 20-20-17

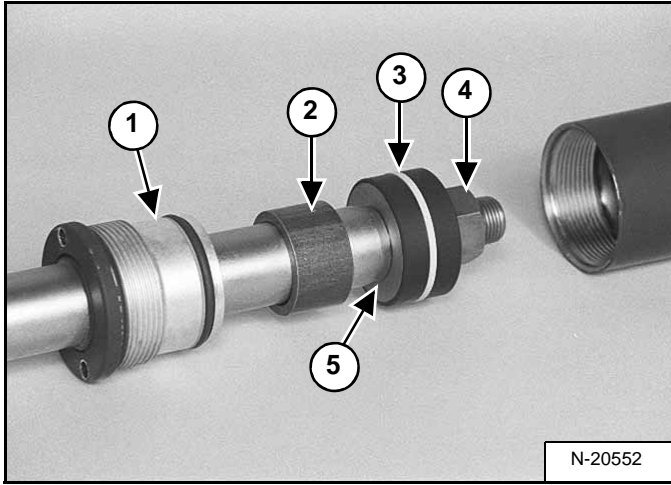

Install the head (Item 1), and spacer (Item 2) [Figure 20-20-17].

Install the piston (Item 3) [Figure 20-20-17].

**NOTE:** The piston center hole (Item 5) [Figure 20-20-17] has a bevel on one end. The bevel goes toward the rod.

Grease the piston where the nut contacts the piston. Do not get grease on the threads. Install the new nut (Item 4) [Figure 20-20-17].

Tighten the nut (Item 4) [Figure 20-20-17] to 300 ft.-lbs. (407 Nm) torque.

Figure 20-20-18

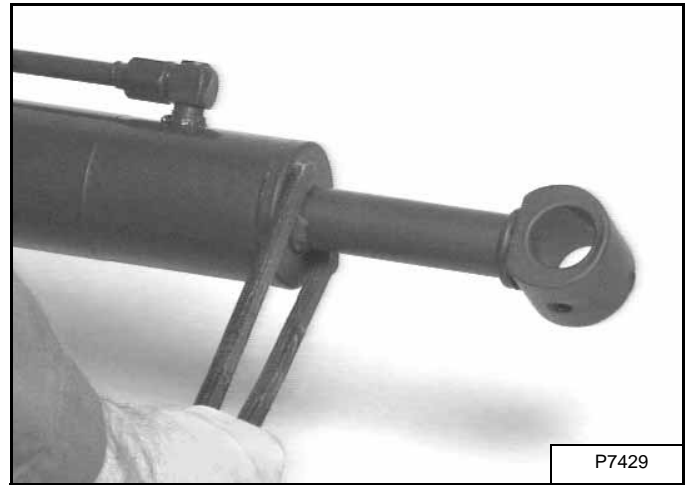

Put the base end of the hydraulic cylinder in a vise.

Tighten the head using a spanner wrench [Figure 20-20-18].

## CYLINDER (POWER BOB-TACH)

### Checking

Figure 20-22-1

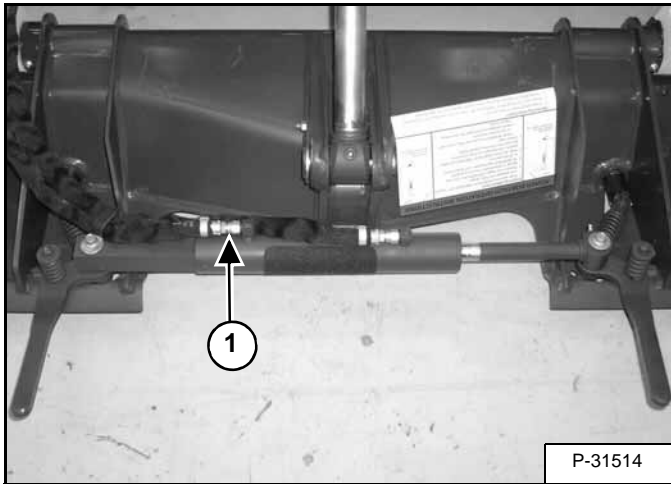

Tilt the Bob-Tach forward, so it is parallel to the floor [Figure 20-22-1].

Disconnect the hose (Item 1) [Figure 20-22-1] from the power Bob-Tach cylinder base end port.

Figure 20-22-2

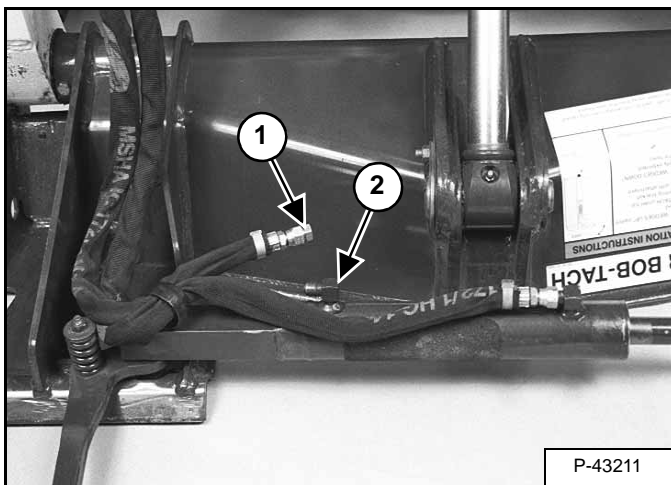

Install a plug in the hose (Item 1) [Figure 20-22-2] and tighten.

Engage the parking brake. Lower the seat bar. Start the engine.

Push and hold the BOB-TACH “WEDGES UP” Switch (Front Accessory Panel).

If there is any leakage from the base end cylinder port (Item 2) [Figure 20-22-2], remove the lift cylinder for repair.

## WARNING

Always clean up spilled fuel or oil. Keep heat, flames, sparks or lighted tobacco away from fuel and oil. Failure to use care around combustibles can cause explosion or fire which can result in injury or death.

W-2103-1285

## WARNING

Diesel fuel or hydraulic fluid under pressure can penetrate skin or eyes, causing serious injury or death. Fluid leaks under pressure may not be visible. Use a piece of cardboard or wood to find leaks. Do not use your bare hand. Wear safety goggles. If fluid enters skin or eyes, get immediate medical attention from a physician familiar with this injury.

W-2072-0496

## MAIN RELIEF VALVE (CONT'D)

### Removal and Installation

Figure 20-30-6

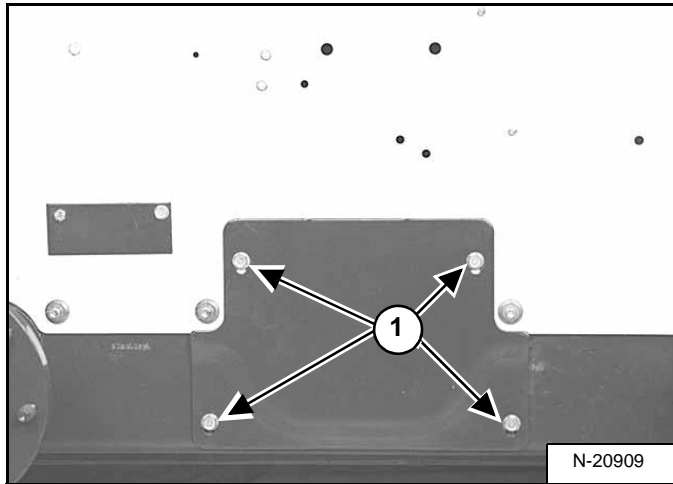

Remove the four motor cover mounting bolts (Item 1) [Figure 20-30-6].

Clean the area around the control valve. Loosen and remove the main relief valve (Item 1) [Figure 20-30-7].

Remove the O-rings and back-up washers [Figure 20-30-5].

Clean the main relief valve in clean solvent. Use air pressure to dry the valve.

Figure 20-30-7

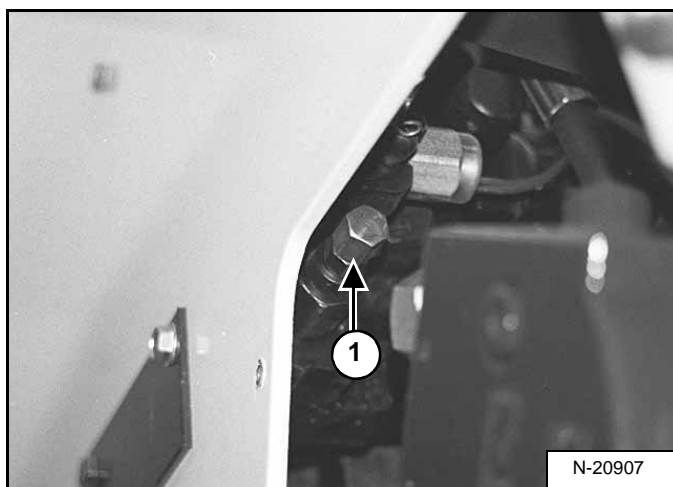

Install new O-rings and back-up washers. Install the main relief valve (Item 1) [Figure 20-30-7] and tighten. Check the pressure again. (See MAIN RELIEF VALVE (CONT'D) on Page 20-30-3.)

**Installation:** Tighten the main relief valve to 35-40 ft.-lbs. (47-54 Nm) torque.

## HYDRAULIC CONTROL VALVE (FOOT CONTROL) (CONT'D)

### Removal And Installation (S/N 515840212 & Above) (Cont'd)

Figure 20-40-27

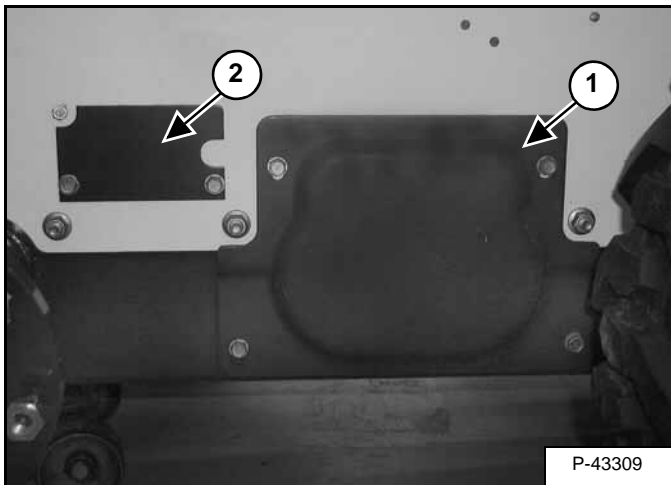

Remove the access covers (Items 1 & 2) [Figure 20-40-27] on the right side of the loader frame.

Figure 20-40-28

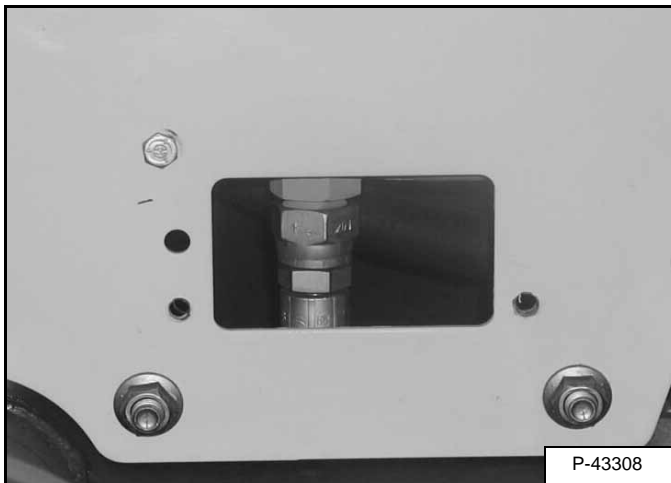

Disconnect the inlet hose from the control valve through the access slot [Figure 20-40-28].

Figure 20-40-29

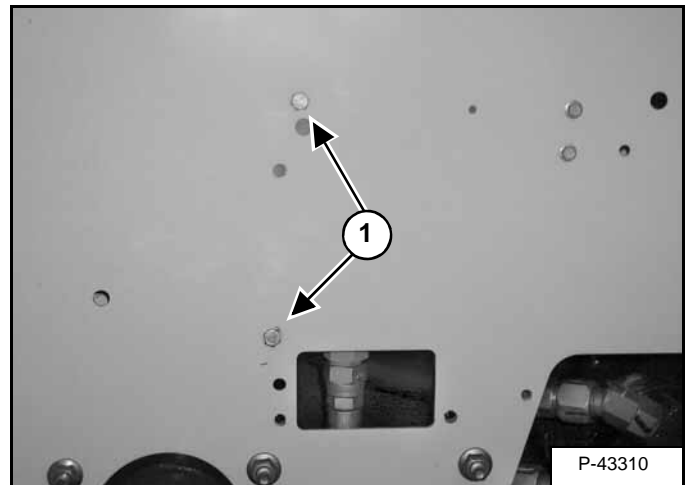

Remove the two control valve mounting bolts/nuts (Item 1) [Figure 20-40-29] from the loader frame.

**Installation:** Tighten the mounting bolt & nut to 18-20 ft.-lbs. (24-27 Nm) torque.

## HYDRAULIC CONTROL VALVE (FOOT CONTROL) (CONT'D)

### Port Relief Valve

Figure 20-40-58

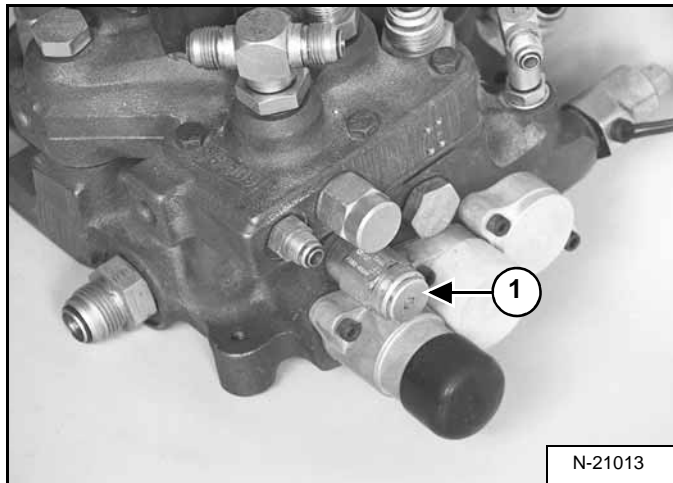

Loosen the port relief valve (Item 1) [Figure 20-40-58] (Port E1).

**Installation:** Always use new O-rings and back-up washers. Tighten to 35-40 ft.-lbs. (47-54 Nm) torque.

Remove the port relief valve.

Figure 20-40-59

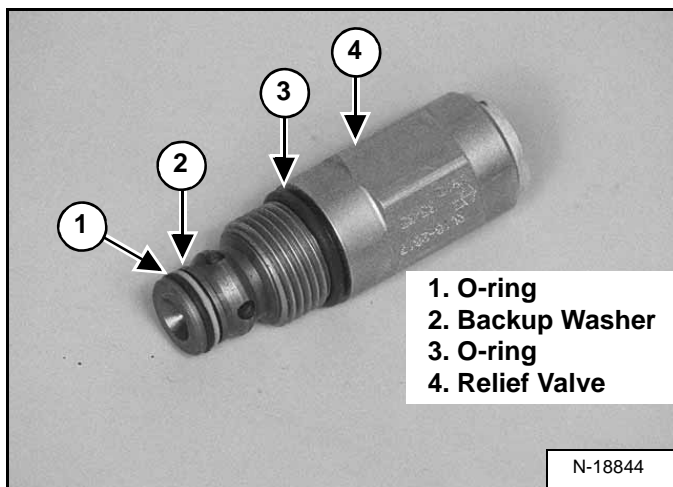

Remove the O-rings and back-up washer from the port relief valve [Figure 20-40-59].

### Anti-Cavitation Valve

Figure 20-40-60

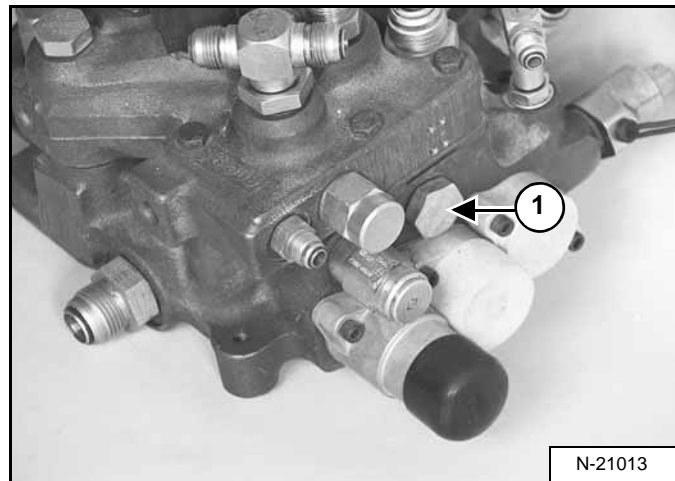

Remove the anti-cavitation valve (Item 1) [Figure 20-40-60] (Port E2) from the control valve for the tilt section.

**Installation:** Always use new O-rings and back-up washers. Tighten to 35-40 ft.-lbs. (47-54 Nm) torque.

## HYDRAULIC CONTROL VALVE (FOOT CONTROL) (CONT'D)

### Lift Spool and Detent (Cont'd)

Figure 20-40-95

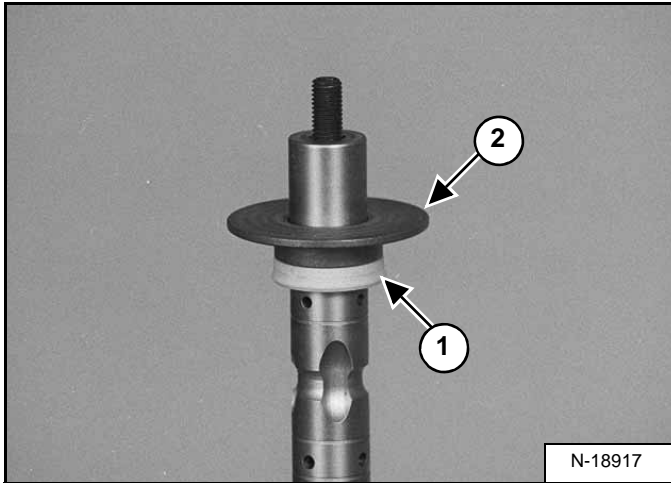

Install the spool seal (Item 1) and back-up washer (Item 2) [Figure 20-40-95].

Figure 20-40-96

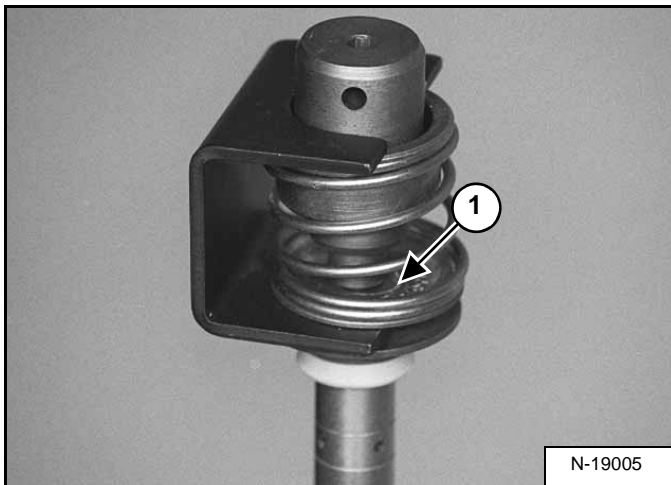

Install the spring assembly to the lift spool hand tight [Figure 20-40-96].

Remove the spring tool.

Check the alignment of the detent adapter and the washer.

Tighten the adapter to 90-100 in.-lbs. (10,2-11,3 Nm).

**NOTE:** The adapter must fit in the center of the washer (Item 1) [Figure 20-40-96].

Figure 20-40-97

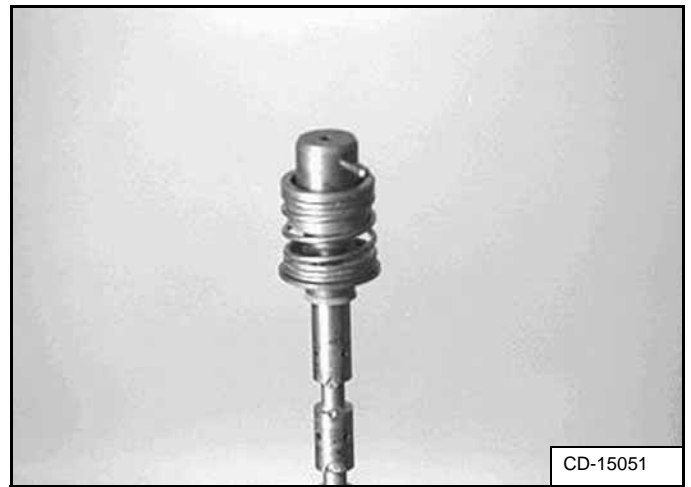

Install the detent balls and spring [Figure 20-40-97].

Figure 20-40-98

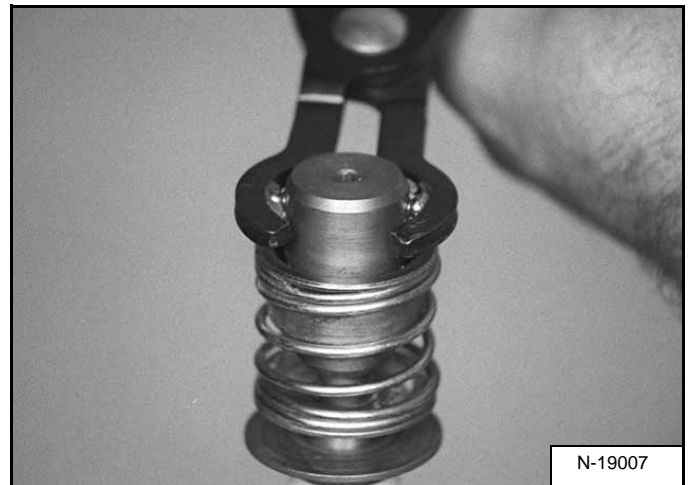

Hold the detent balls in place with the detent pliers [Figure 20-40-98].



**HYDRAULIC CONTROL VALVE (ADVANCED CONTROL SYSTEM) (ACS) (CONT'D)**

**BICS™ Valve, Solenoid Removal and Installation**

**Figure 20-41-42**

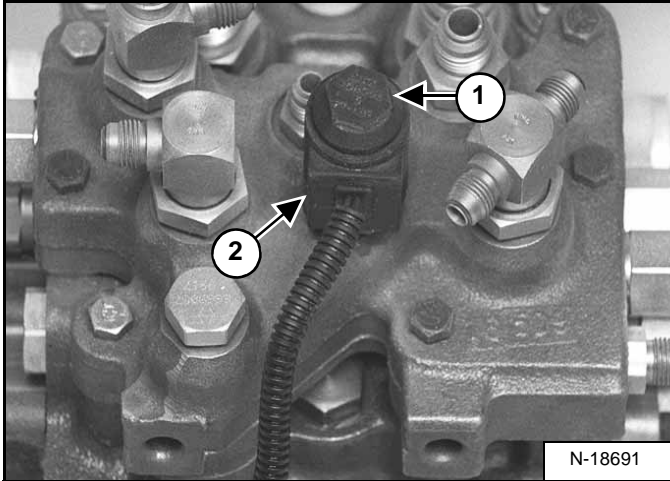

Remove the mounting nut (Item 1) [Figure 20-41-42] from the solenoid cartridge.

**Installation:** Tighten the mounting nut to 53 in.-lbs. (6 Nm) torque.

Remove the solenoid (Item 2) [Figure 20-41-42].

**NOTE:** The solenoid resistance valve is (8-10 ohms).

**Figure 20-41-43**

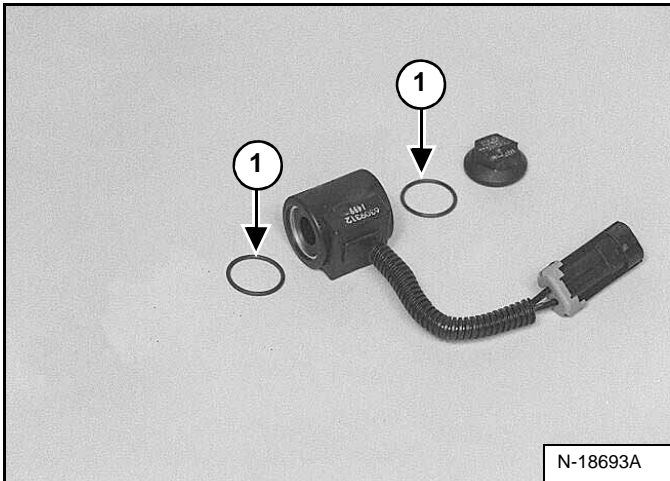

Remove the O-rings (Item 1) [Figure 20-41-43] from both ends of the solenoid.

**Figure 20-41-44**

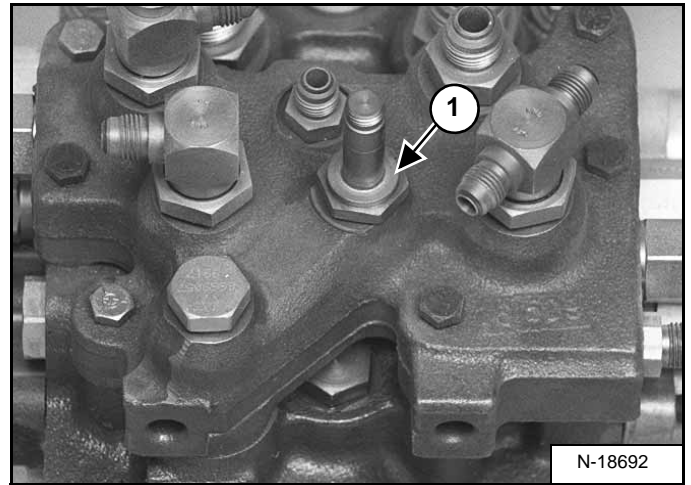

Remove the solenoid cartridge (Item 1) [Figure 20-41-44].

**Installation:** Tighten the cartridge to 20 ft.-lbs. (27 Nm) torque.

## HYDRAULIC CONTROL VALVE (ADVANCED CONTROL SYSTEM) (ACS) (CONT'D)

### Tilt Spool Removal And Installation

Figure 20-41-70

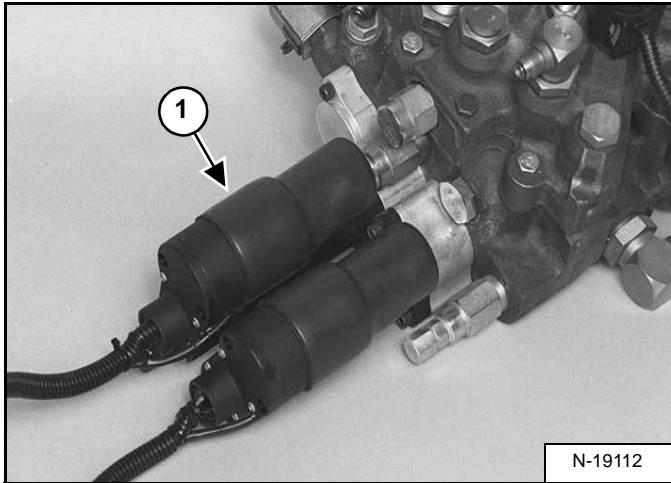

Remove the actuators (Item 1) [Figure 20-41-70] from the control valve. (See Actuator Removal And Installation on Page 20-41-8.)

Figure 20-41-71

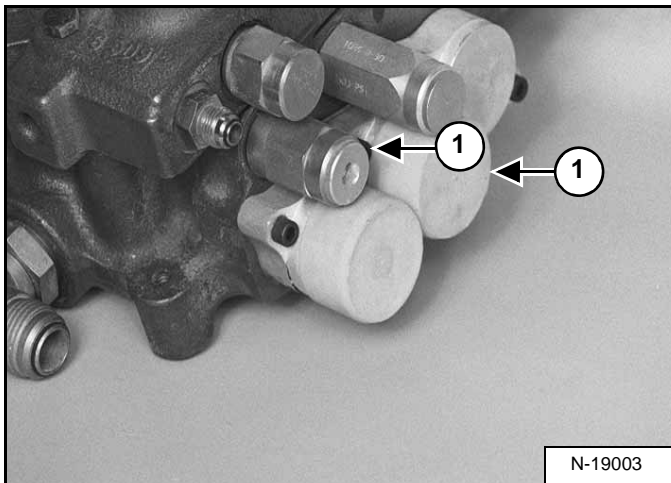

Remove the screws (Item 1) [Figure 20-41-71] from the end cap.

**Installation:** Tighten the bolt to 90-100 in.-lbs. (10,2-11,3 Nm) torque.

Figure 20-41-72

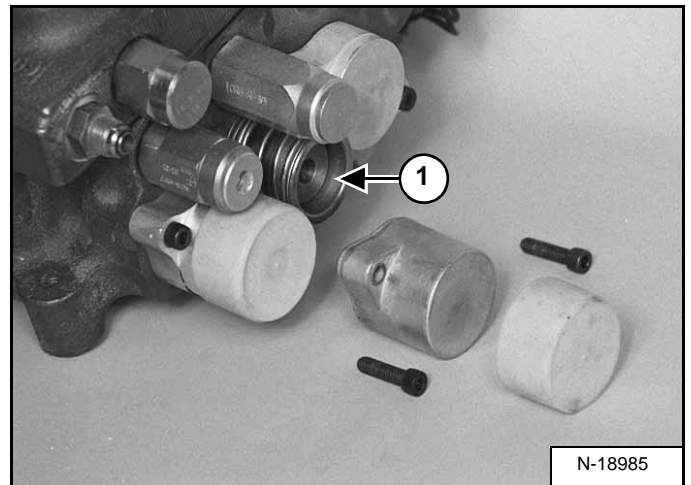

Remove the spool assembly (Item 1) [Figure 20-41-72] and seal from the control valve.

**Assembly:** Always use a new spool seal and new O-rings.

## HYDRAULIC PUMP (ALUMINUM) (CONT'D)

### Removal And Installation (Cont'd)

Figure 20-60-4

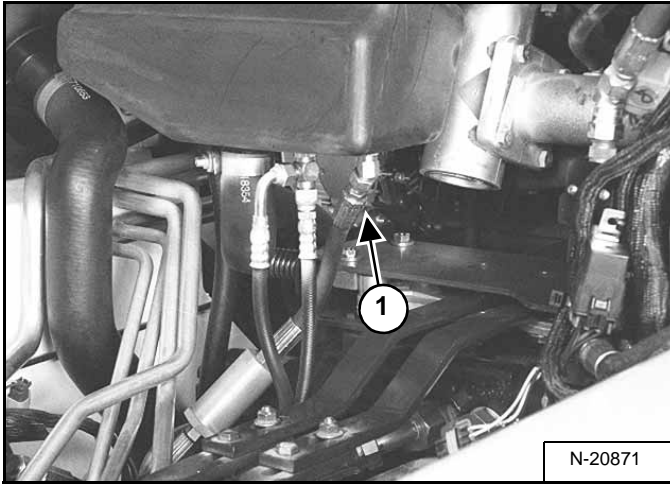

Disconnect the case drain hose (Item 1) [Figure 20-60-4] from the right drive motor.

Drain the hydraulic fluid (using the case drain hose) from the reservoir.

Figure 20-60-5

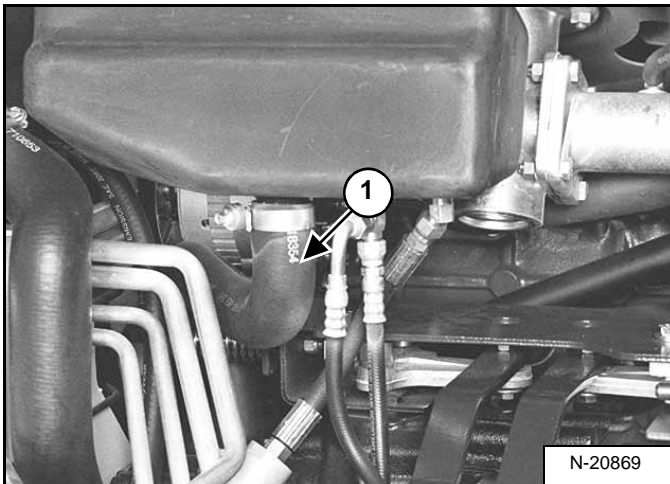

Disconnect the hydraulic pump inlet hose (Item 1) [Figure 20-60-5] from the reservoir and drain as much fluid from the hose as possible. Reconnect the hose to the reservoir.

Figure 20-60-6

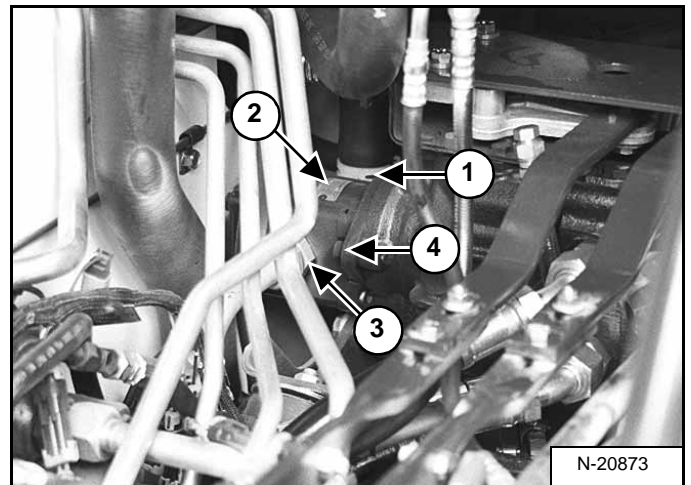

Disconnect the inlet hose (Item 1) from the hydraulic pump (Item 2) [Figure 20-60-6].

Disconnect the hydraulic pump outlet tubeline (Item 3) [Figure 20-60-6] from the outlet fitting.

Figure 20-60-7

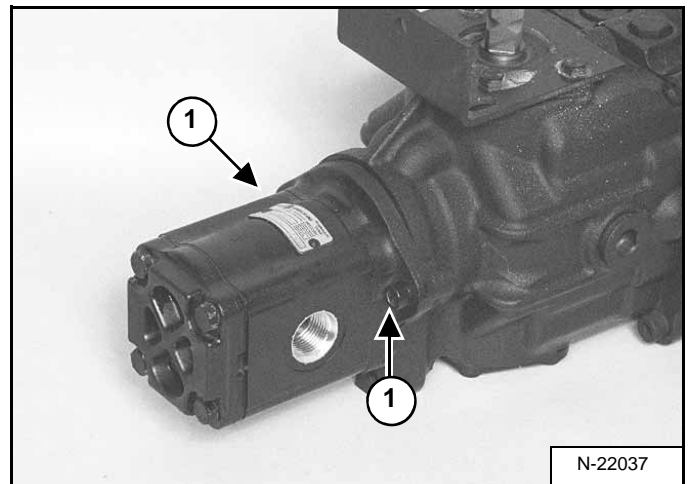

Remove the two mounting bolts (Item 4) [Figure 20-60-6] & (Item 1) [Figure 20-60-7] from the hydraulic pump with a 5/16 inch allen wrench.

**NOTE:** The allen wrench will need to be modified for the procedure.

**Installation:** Tighten the mounting bolts to 27-37 ft.-lbs. (37-50 Nm) torque.

Remove the hydraulic pump from the hydrostatic pump.

## HYDRAULIC PUMP (CAST IRON) (CONT'D)

### Removal And Installation

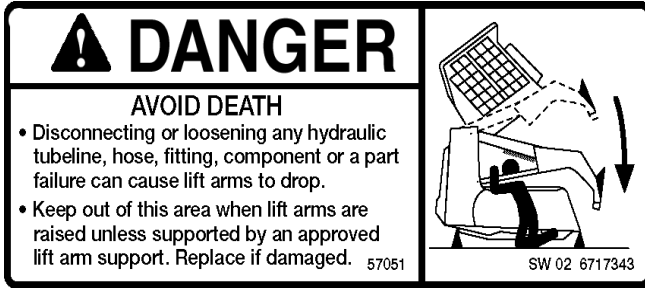

Never work on a machine with the lift arms up unless the lift arms are secured by an approved lift arm support device. Failure to use an approved lift arm support device can allow the lift arms or attachment to fall and cause injury or death.

W-2059-0598

Raise the lift arms and install an approved lift arm support device. (See Installing Lift Arm Support Device on Page 10-20-1.)

Stop the engine. Raise the seat bar.

Lift and block the loader. (See LIFTING AND BLOCKING THE LOADER on Page 10-10-1.)

Raise the operator cab. (See Raising The Operator Cab on Page 10-30-1.)

Drain the hydraulic fluid from the reservoir. (See Replacing Hydraulic Fluid on Page 10-120-3.)

Remove the hydraulic fluid reservoir from the loader. (See Housing Removal And Installation on Page 20-70-1.)

Open the rear door of the loader.

Remove the Power Bob-Tach block if so equipped. (See Removal And Installation on Page 20-110-1.)

Figure 20-61-11

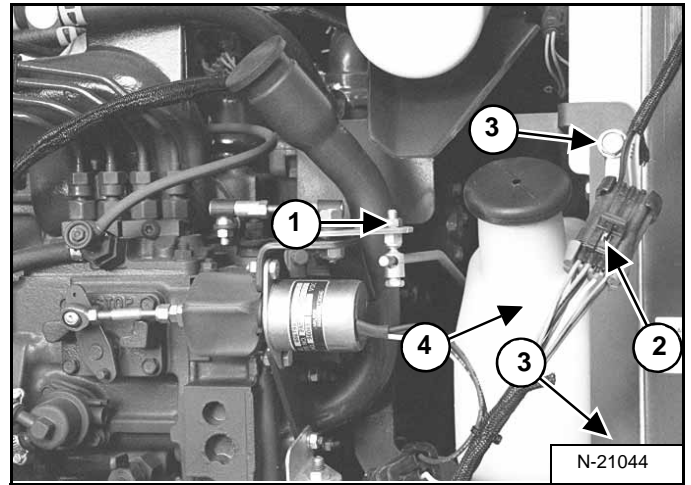

Remove the nut from the speed control linkage (Item 1) [Figure 20-61-11].

Unplug the rear lights electrical connector (Item 2) [Figure 20-61-11].

Remove the belt shield mounting bolts (Item 3) [Figure 20-61-11].

Remove the belt shield.

Remove the coolant recover tank and mount (Item 4) [Figure 20-61-11].

Figure 20-61-12

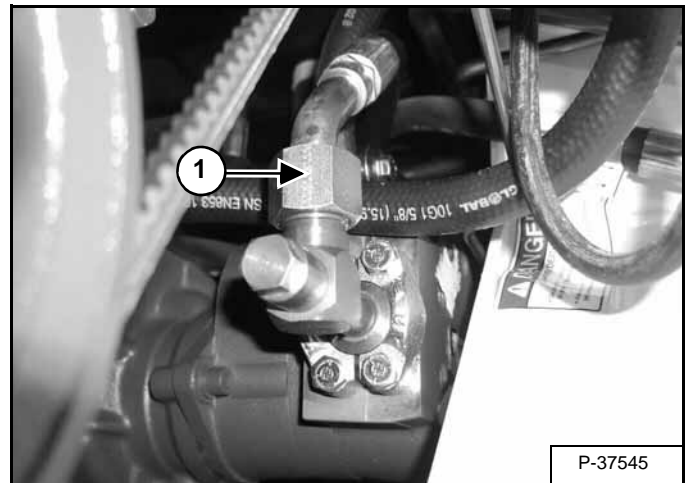

Disconnect and cap the outlet hose (Item 1) [Figure 20-61-12] from the back of the hydraulic pump.

## HYDRAULIC/HYDROSTATIC FILTER

### Housing Removal And Installation

# IMPORTANT

When repairing hydrostatic and hydraulic systems, clean the work area before disassembly and keep all parts clean. Always use caps and plugs on hoses, tubelines and ports to keep dirt out. Dirt can quickly damage the system.

I-2003-0888

Stop the engine and open the rear door.

Figure 20-70-1

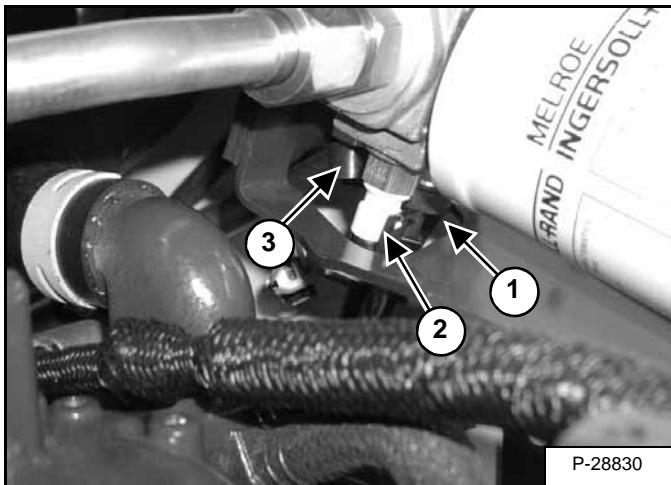

Disconnect the charge pressure sender connector (Item 1), temperature sender connector (Item 2) and differential pressure switch connector (Item 3) [Figure 20-70-1] from the filter housing.

Figure 20-70-2

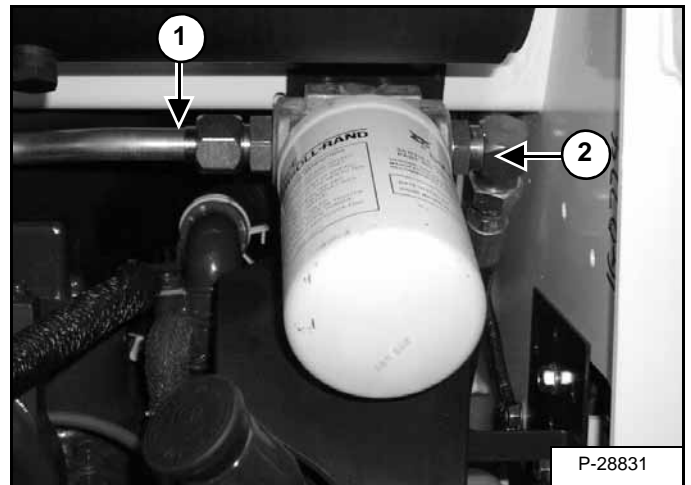

Disconnect the oil cooler tubeline (Item 1) [Figure 20-70-2] from the filter housing.

Disconnect the hose (Item 2) [Figure 20-70-2] from the filter housing outlet.

Figure 20-70-3

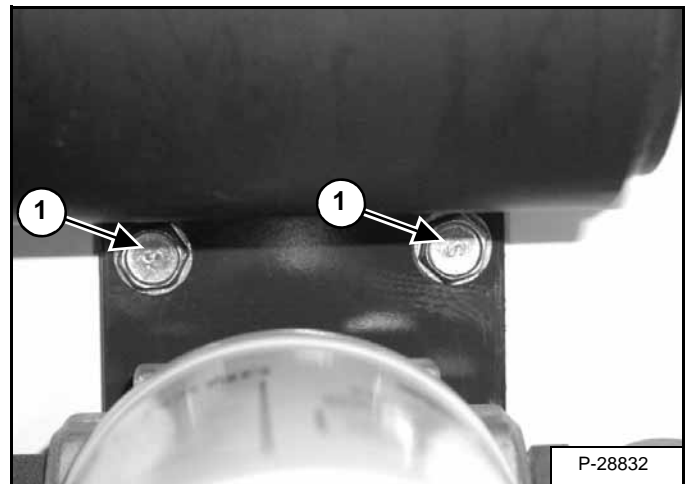

Remove the two mounting bolts (Item 1) [Figure 20-70-3] from the filter housing mounting bracket.

**Installation:** Tighten the mounting bolts to 190-240 ins.-lbs. (29,2-36,7 Nm) torque.

## REAR AUXILIARY DIVERTER VALVE (SINGLE SHUTTLE)

### Removal And Installation



Never work on a machine with the lift arms up unless the lift arms are secured by an approved lift arm support device. Failure to use an approved lift arm support device can allow the lift arms or attachment to fall and cause injury or death.

W-2059-0598

**NOTE: The single shuttle rear auxiliary diverter valve is a silver color block.**

Lift and block the loader. (See LIFTING AND BLOCKING THE LOADER on Page 10-10-1.)

Raise the lift arms and install an approved lift arm support device. (See Installing Lift Arm Support Device on Page 10-20-1.)

Raise the operator cab. (See Raising The Operator Cab on Page 10-30-1.)

Remove air cleaner. (See Removal And Installation on Page 70-40-1.)

Remove drive belt shield. (See Shield Removal And Installation on Page 30-50-1.)

Figure 20-100-1

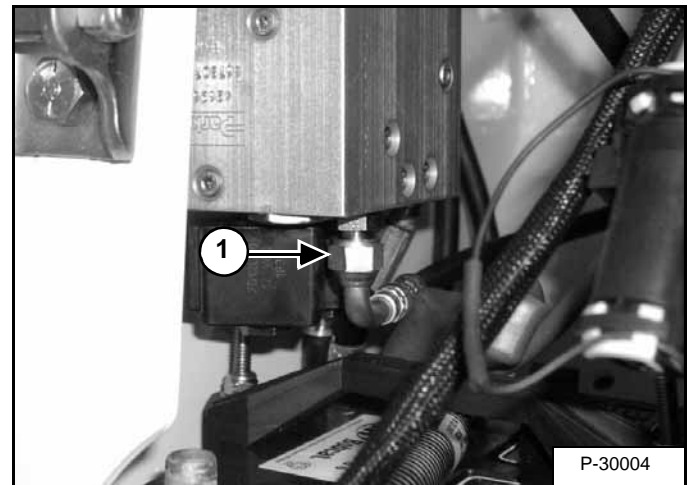

Disconnect pilot line (Item 1) [Figure 20-100-1] from diverter block.

Remove the battery. (See Removal And Installation on Page 60-20-1.)

Figure 20-100-2

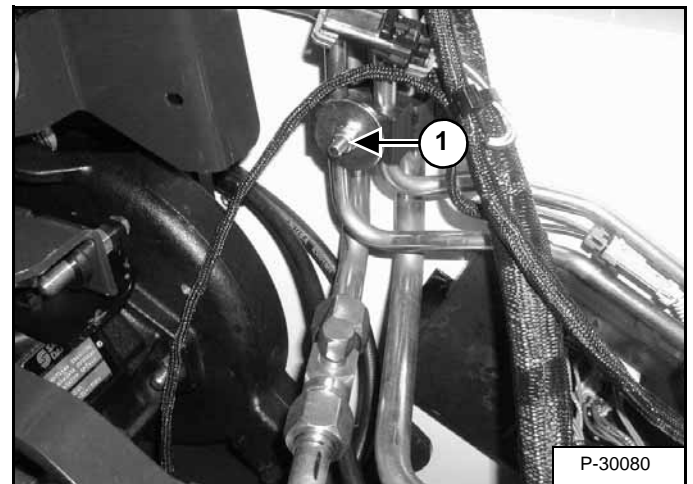

Loosen the bolt on clamp (Item 1) [Figure 20-100-2] to aid in tubeline removal.

## REAR AUXILIARY DIVERTER VALVE (DUAL SHUTTLE) (CONT'D)

### Disassembly And Assembly (Cont'd)

Figure 20-101-21

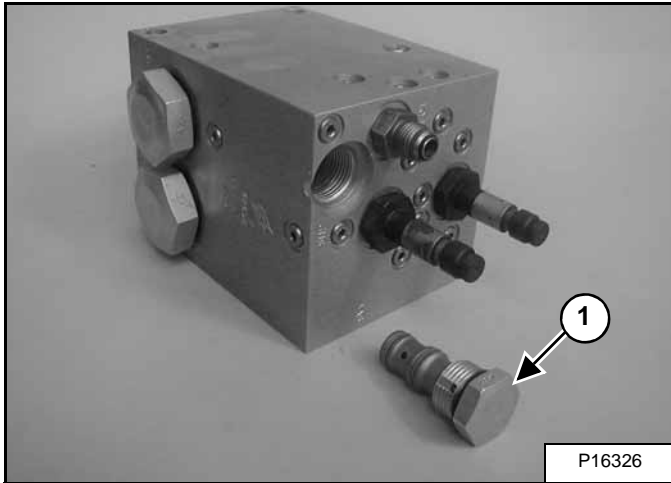
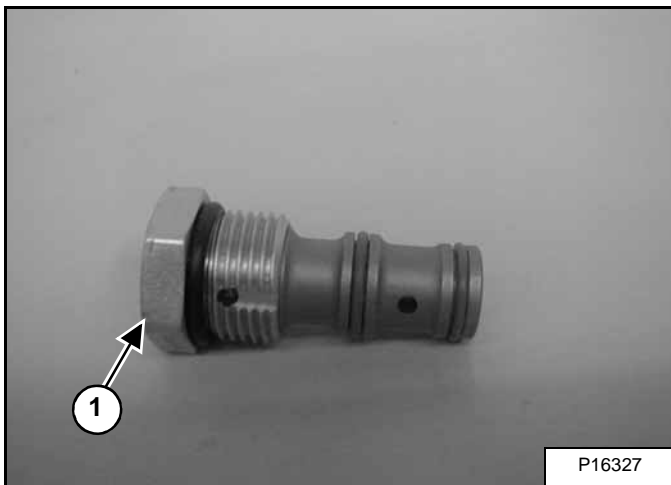

Figure 20-101-22



Remove the shuttle check valve (Item 1) [Figure 20-101-21] & [Figure 20-101-22] from the SH2 port.

**Installation:** Put oil on O-ring and back-up washers. Tighten to 30-35 ft.-lbs. (40,7-47,5 Nm) torque.

## Solenoid Testing

Figure 20-101-23

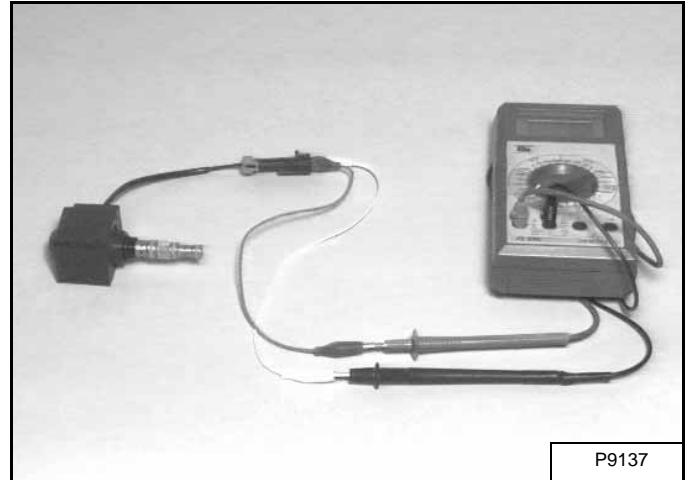

Use a test meter to measure coil resistance [Figure 20-101-23]. Coil wires do not have polarity. Correct resistance is 6-9 ohms.

Replace the test meter with 12 volt power. You can see and hear the spool shift.

### Inspection

Inspect cartridges, check valves, solenoid valves and sealing washers for contamination or damage. Wash all parts in clean solvent. Use air pressure for drying them. Install new O-rings and back-up washers.

Inspect diverter block cavities for contamination. Wash block in clean solvent. Use air pressure to dry.

## POWER BOB-TACH BLOCK (CONT'D)

### Disassembly And Assembly (Cont'd)

Figure 20-110-29

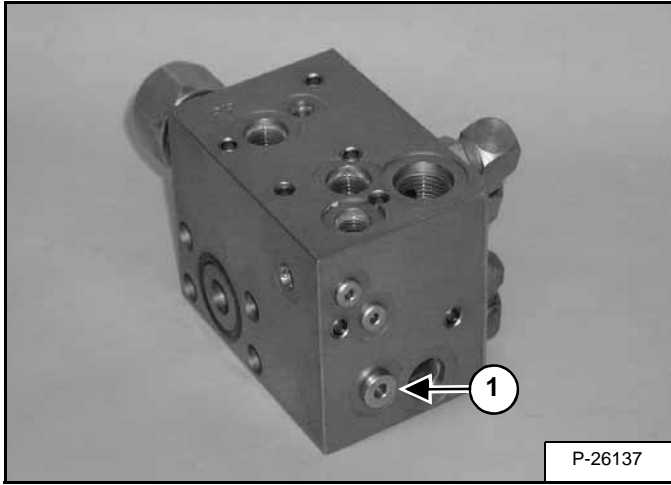

Remove the plug (Item 1) [Figure 20-110-29].

Installation: Tighten the plug to 120 in.-lbs. (13,6 Nm) torque.

Figure 20-110-30

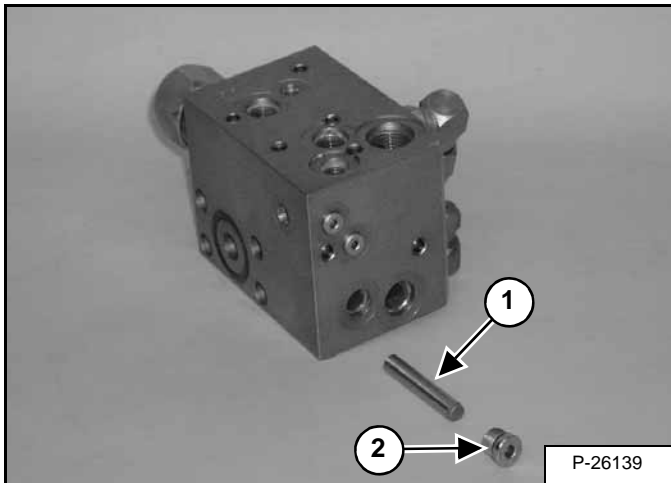

Remove the dowel pin orifice (Item 1) [Figure 20-110-30].

Check the O-ring (Item 2) [Figure 20-110-30] and replace as needed.

Figure 20-110-31

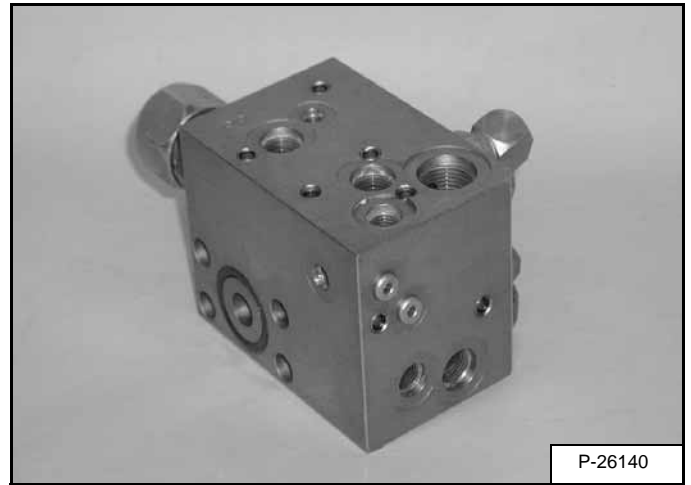
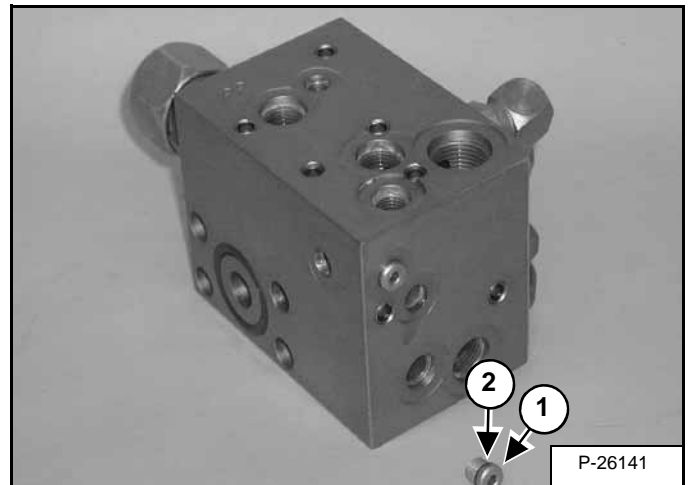

Figure 20-110-32



Remove the plug (Item 1) [Figure 20-110-31] & [Figure 20-110-32].

**Installation:** Tighten the plug to 32 in.-lbs. (3,6 Nm) torque.

Check the O-ring (Item 2) [Figure 20-110-32] and replace as needed.

## HYDROSTATIC SYSTEM INFORMATION

### Troubleshooting Chart

The following troubleshooting chart is provided for assistance in locating and correcting problems which are most common. Many of the recommended procedures must be done by authorized Bobcat Service Personnel only.



**Check for correct function after adjustments, repairs or service. Failure to make correct repairs or adjustments can cause injury or death.**

W-2004-1285

PROBLEM	CAUSE
No drive on one side, in one direction.	1, 2
No drive on one side in both directions.	2, 3, 4, 5
The loader does not move in a straight line.	2, 3, 5, 6, 7
The hydrostatic system is overheating.	8, 9, 10, 11
Service code HP2 appears. (Warnings, low charge pressure.)	8, 11, 12, 13

KEY TO CORRECT THE CAUSE
1. The hydrostatic pump replenishing valves not seating.
2. The steering linkage needs adjustment.
3. The hydrostatic pump has damage.
4. The final drive chains are broken.
5. The hydrostatic motor has damage.
6. The tires do not have the correct tire pressure.
7. The tires are not the same size.
8. The hydrostatic fluid is not at the correct level.
9. The oil cooler has a restriction.
10. The temperature sending switch is not operating correctly.
11. The loader is not being operated at the correct RPM.
12. The hydraulic charge pressure sender is defective.
13. Pump is defective or worn hydrostatics.

## HYDROSTATIC MOTOR (CONT'D)

### Assembly

# IMPORTANT

When repairing hydrostatic and hydraulic systems, clean the work area before disassembly and keep all parts clean. Always use caps and plugs on hoses, tubelines and ports to keep dirt out. Dirt can quickly damage the system.

I-2003-0888

*Prior to assembly:*

Clean all parts with solvent and dry with compressed air.

Put grease on O-rings.

Lubricate parts with oil.

**Figure 30-20-26**

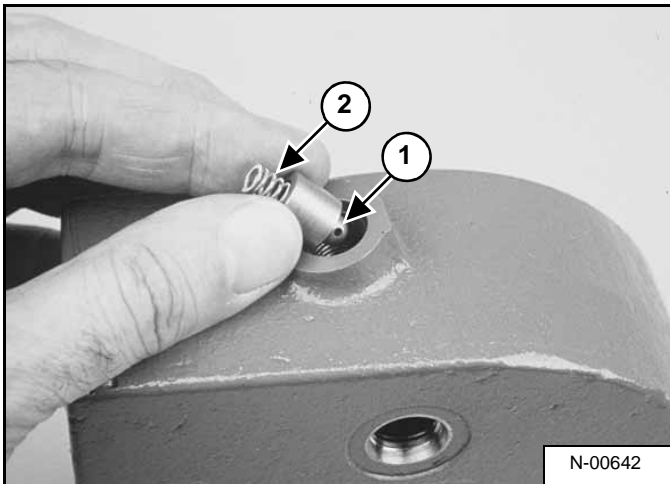

Install the poppet (Item 1) and spring (Item 2) [Figure 30-20-26] in the low pressure relief port in the end cover.

**Figure 30-20-27**

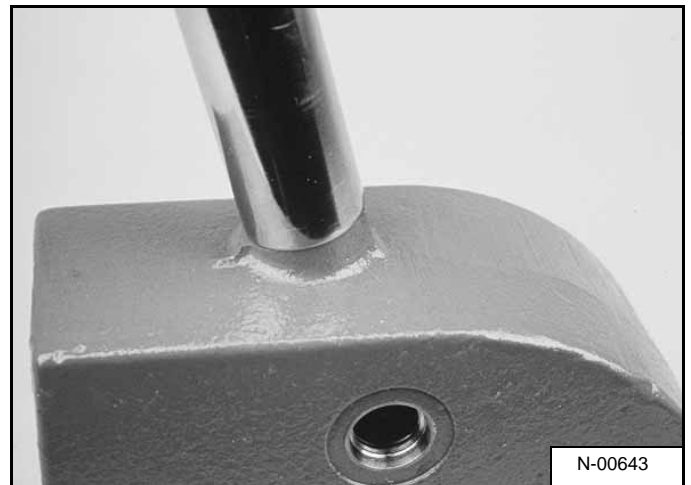

Install the new O-ring on the plug and tighten to 300 in.-lbs. (34 Nm) torque [Figure 30-20-27].

**Figure 30-20-28**

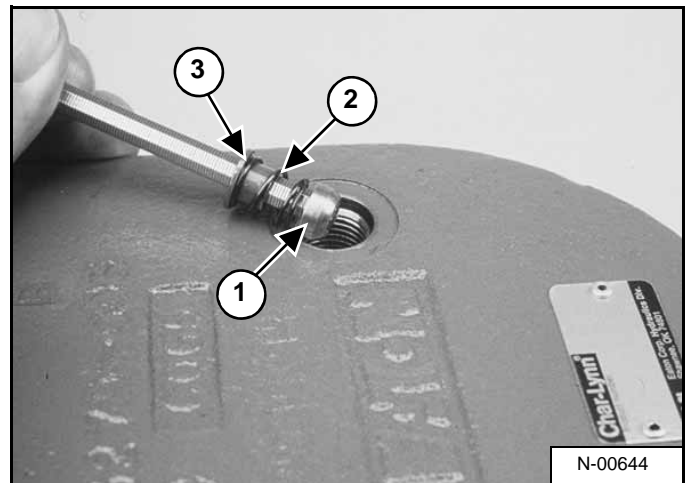

Install the poppet (Item 1), the spring (Item 2) and the spring sleeve (Item 3) [Figure 30-20-28] in the end cover.

**NOTE:** The tapered end of the poppet must face towards the shuttle valve.

# HYDROSTATIC MOTOR (CONT'D)

## Carrier Parts Identification

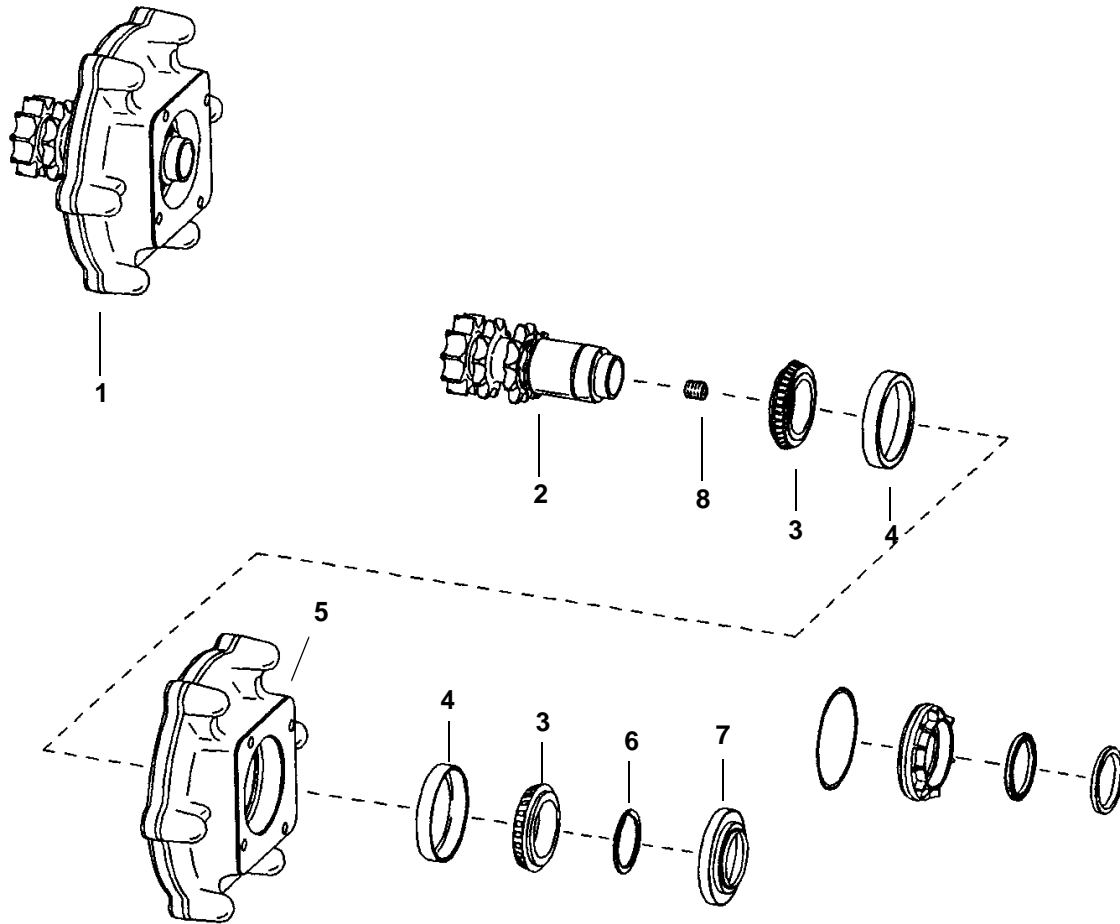

- 1. Mount Assy.
- 2. Shaft
- 3. Bearing
- 4. Race
- 5. Housing
- 6. Snap Ring
- 7. Seal
- 8. Plug

MC-1937

## HYDROSTATIC PUMP (CONT'D)

### Removal And Installation (Cont'd)

Figure 30-40-5

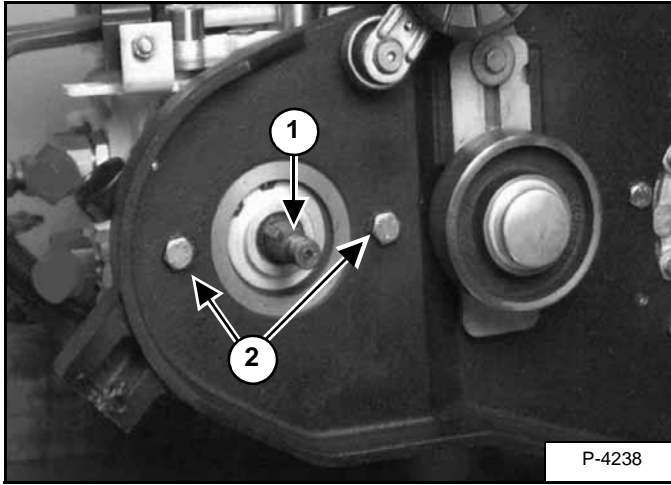

**Installation:** Install the key in the hydrostatic pump shaft (Item 1) [Figure 30-40-5] before installing the pump drive pulley.

Figure 30-40-6

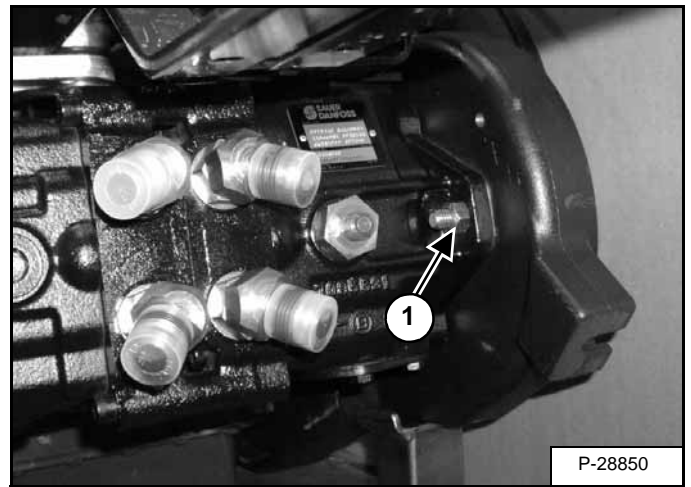

Hold the nut (Item 1) [Figure 30-40-6] on the two hydrostatic pump mounting bolts (Item 2) [Figure 30-40-5].

Remove the two hydrostatic pump mounting bolts (Item 2) [Figure 30-40-5] from the pump and drive belt housing.

**Installation:** Tighten the pump mounting bolts to 65-70 ft.-lbs. (88-95 Nm) torque.

Reverse the removal procedure to install the hydrostatic pump assembly.

## HYDROSTATIC PUMP (CONT'D)

### Disassembly (Cont'd)

Figure 30-40-27

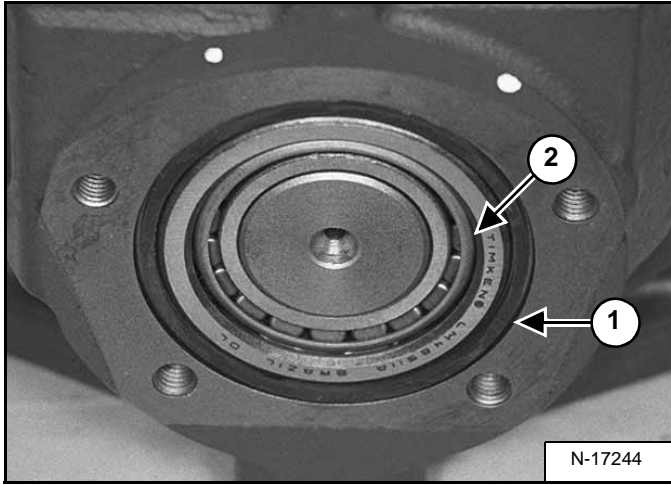

Remove the O-ring (Item 1) and bearing race (Item 2) [Figure 30-40-27] from the pump housing.

Figure 30-40-28

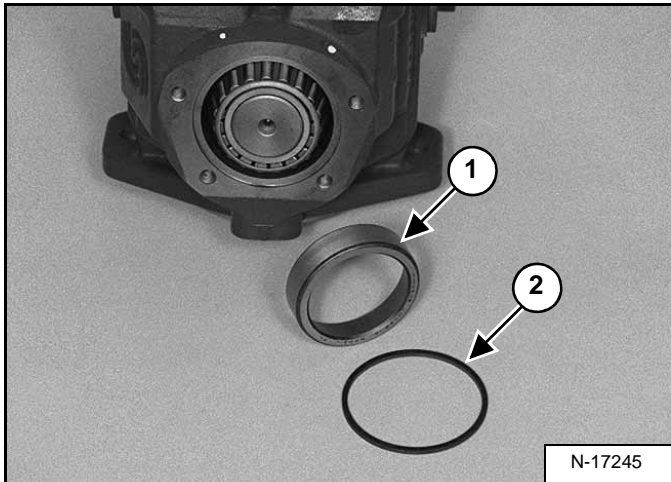

Check the bearing race (Item 1) and O-ring (Item 2) [Figure 30-40-28] for wear and replace as needed.

Figure 30-40-29

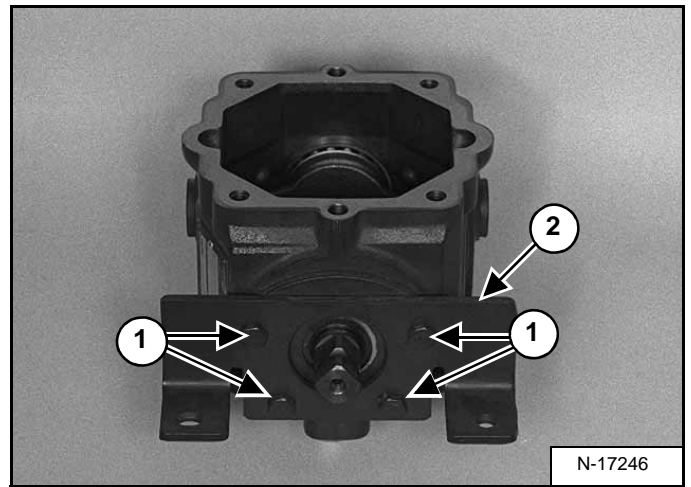

Remove the four mount bolts (Item 1) from the pump housing and remove the steering bracket (Item 2) [Figure 30-40-29].

Figure 30-40-30

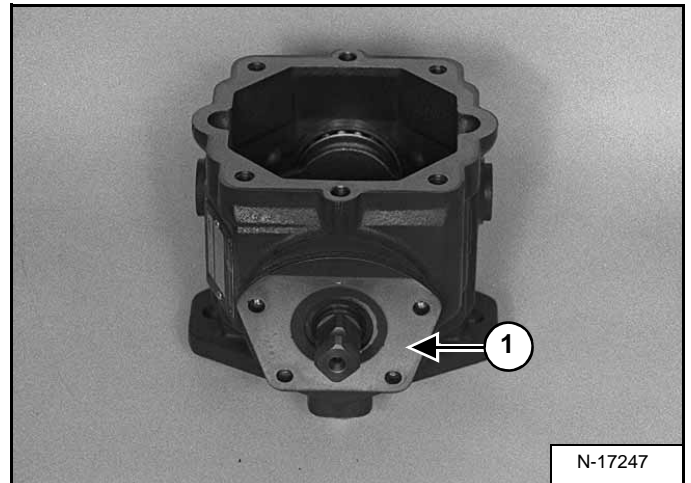

Remove the upper trunnion cover (Item 1) [Figure 30-40-30].

## DRIVE BELT

### Shield Removal And Installation

Figure 30-50-1

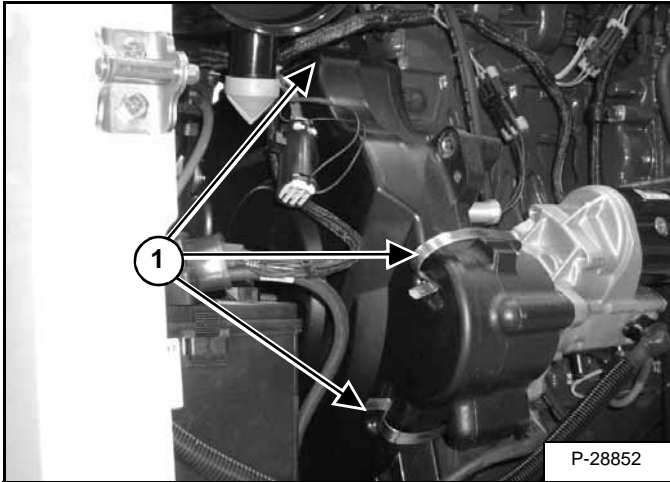

Remove the three drive belt shield mounting clips (Item 1) [Figure 30-50-1].

### Adjusting

Figure 30-50-2

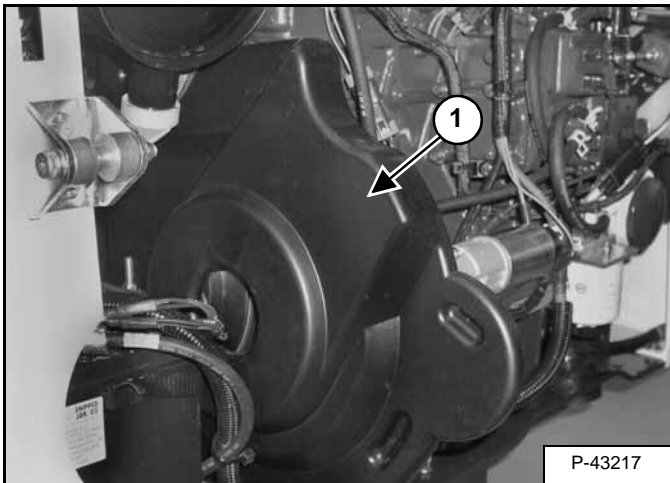

To adjust the drive belt between the flywheel and the hydrostatic pump pulley, use the following procedure:

Stop the engine. Open the rear door.

Disconnect the negative (-) battery cable.

Remove the belt shield (Item 1) [Figure 30-50-2].

The pulley tensioner is located between the flywheel and pump pulley.

Figure 30-50-3

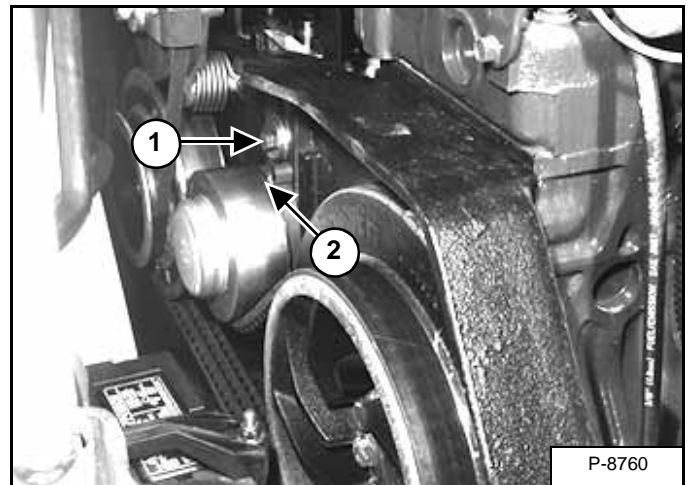

Loosen the bolt (Item 1) [Figure 30-50-3] on the spring loaded drive idler.

**NOTE:** The pointer (Item 2) [Figure 30-50-3] will be at the 1 o'clock position when the idler is not under spring tension.

## DRIVE SYSTEM

## DRIVE SYSTEM

BRAKE .....	40-10-1
Disc Removal And Installation .....	40-10-2
Pedal Disassembly And Assembly .....	40-10-1
Pedal Removal And Installation (S/N 515834999 & Below) . . .	40-10-1
Switch Operated Parking Brake (S/N 515835000 & Above) . . .	40-10-3
CHAINCASE .....	40-30-1
Center Cover Removal And Installation .....	40-30-3
Checking And Adding Oil .....	40-30-1
Front Cover Removal And Installation .....	40-30-2
Rear Cover Removal And Installation .....	40-30-4
Removing The Oil .....	40-30-1
DRIVE COMPONENTS .....	40-20-1
Axle Seal Removal And Installation .....	40-20-1
Axle Sprocket And Bearings Removal And Installation .....	40-20-3
Chain Removal And Installation .....	40-20-8

**TIGHTEN ALL HARDWARE PER SIZE TO GRADE 5 TORQUE (See TORQUE SPECIFICATIONS FOR BOLTS on Page SPEC-30-1.) UNLESS OTHERWISE SPECIFIED.**

## DRIVE COMPONENTS (CONT'D)

### Axle Sprocket And Bearings Removal And Installation (Cont'd)

Figure 40-20-11

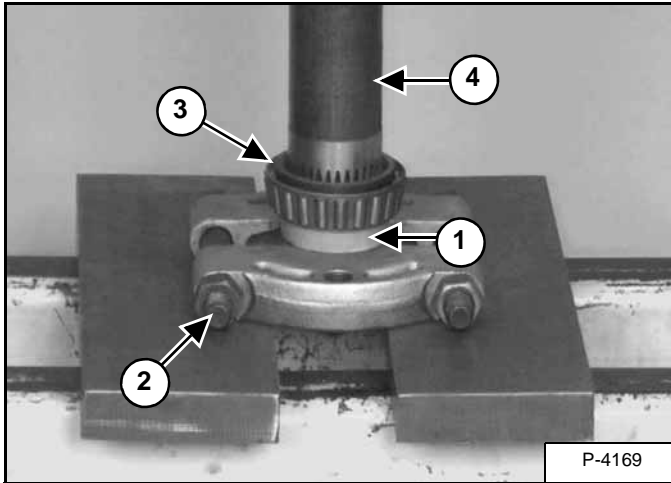

**Installation:** A piece of round tubing (Item 1) [Figure 40-20-11] is needed to install the bearing on the axle shaft. The tubing needs to measure approximately 0.500 inch (12,7 mm) to 1.0 inch (25,4 mm) in length. The inside diameter of the tubing should not be under 2.100 inches (53,3 mm) and the outside diameter should not be over 2.400 inches (60 mm),

A bearing puller (Item 2) [Figure 40-20-11] is also needed to install the bearing on the axle.

Put the tubing (Item 1) on the bearing puller (Item 2) [Figure 40-20-11].

Put the bearing (Item 3) [Figure 40-20-11] on the tube as shown.

Put the spline end of the axle shaft (Item 4) [Figure 40-20-11] in the bearing and press the bearing onto the axle.

Be sure to hold onto the axle during installation, as it will slide freely along the axle shaft after the spline end has passed through the bearing and until it reaches the bearing mounting surface on the axle.

Figure 40-20-12

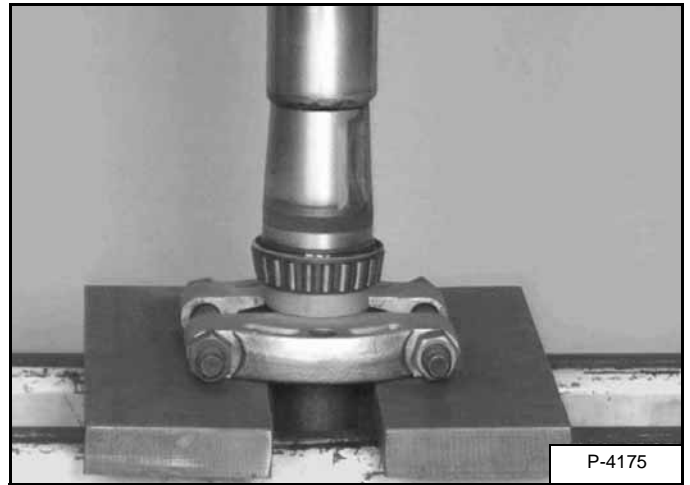

When the bearing reaches the bearing mounting surface, continue the installation until the bearing is fully seated [Figure 40-20-12].

Figure 40-20-13

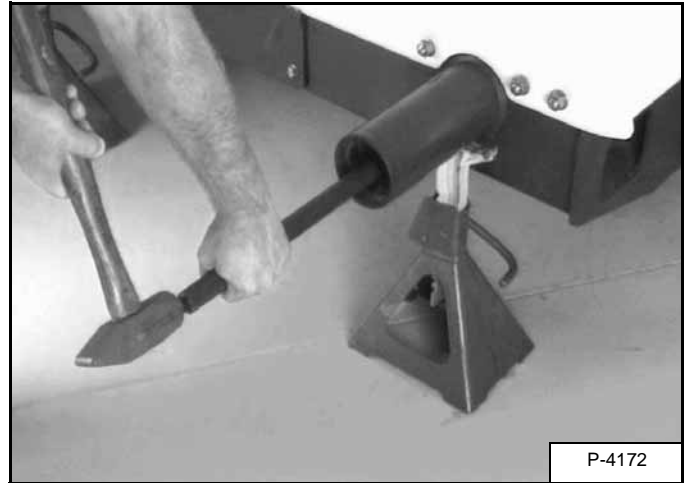

Use the tools provided in the MEL1202B Axle Bearing Service Set for bearing cup removal and installation. A slide hammer is also necessary for this procedure.

Use the long rod and bearing cup tool to remove the inner bearing cup [Figure 40-20-13].

Hit the long rod with a hammer to remove the bearing cup from the axle tube [Figure 40-20-13].

## MAIN FRAME

## MAIN FRAME

BOB-TACH . . . . .	50-40-1
Bob-Tach Lever And Wedge . . . . .	50-40-3
Bob-Tach Stops . . . . .	50-40-4
Removal And Installation . . . . .	50-40-1
CONTROL HANDLE . . . . .	50-110-1
Lever Removal And Installation . . . . .	50-110-2
Linkage Adjustment . . . . .	50-110-5
Linkage Neutral Adjustment . . . . .	50-110-8
Linkage Removal And Installation . . . . .	50-110-3
Rubber Boot Replacement . . . . .	50-110-2
Shaft Disassembly And Assembly . . . . .	50-110-1
Shaft Removal And Installation . . . . .	50-110-1
Shock Removal And Installation . . . . .	50-110-1
CONTROL HANDLE (ADVANCED HAND CONTROL) (AHC) . .	50-111-1
Components Identification . . . . .	50-111-1
Control Handle Disassembly And Assembly . . . . .	50-111-5
Control Handle Removal And Installation . . . . .	50-111-5
Control Lever Boot . . . . .	50-111-7
Control Lever Removal And Installation . . . . .	50-111-6
Handle Control Unit Removal And Installation . . . . .	50-111-2
CONTROL HANDLE (ADVANCED HAND CONTROL) (AHC) W/PUSH BUTTON FLOAT . . . . .	50-112-1
Components Identification . . . . .	50-112-1
Control Lever Boot . . . . .	50-112-6
Control Lever Removal And Installation . . . . .	50-112-5
Control Handle Disassembly And Assembly . . . . .	50-112-4
Control Handle Removal And Installation . . . . .	50-112-3
Handle Sensor Removal And Installation . . . . .	50-112-1
CONTROL HANDLE (ADVANCED CONTROL SYSTEM) (ACS) ADVANCED HAND CONTROL . . . . .	50-113-1
Components Identification . . . . .	50-113-1
Control Handle Disassembly and Assembly . . . . .	50-113-6
Control Handle Removal and Installation . . . . .	50-113-5
Control Lever Boot . . . . .	50-113-7
Control Lever Removal and Installation . . . . .	50-113-6
Handle Sensor Removal And Installation . . . . .	50-113-1

Continued On Next Page

## OPERATOR CAB

### Gas Cylinder Removal And Installation

# WARNING

Cylinder contains high pressure gas. Do not open. Opening cylinder can release rod and cause injury or death.

W-2113-0288

# WARNING

Never work on a machine with the lift arms up unless the lift arms are secured by an approved lift arm support device. Failure to use an approved lift arm support device can allow the lift arms or attachment to fall and cause injury or death.

W-2059-0598

Figure 50-20-1

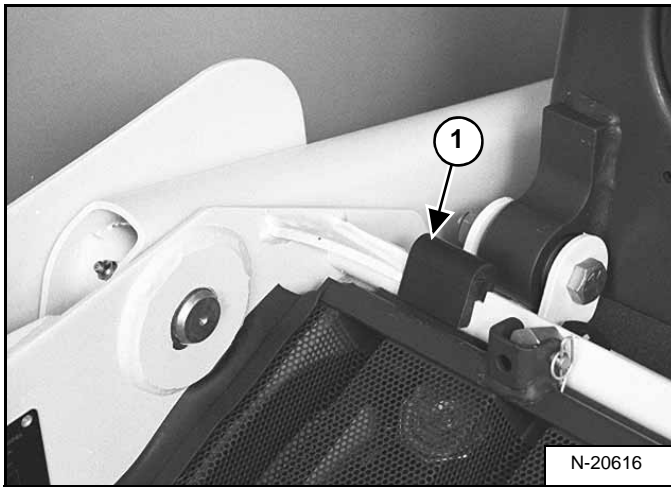

Remove the operator cab stop (Item 1) (both sides) [Figure 50-20-1].

Figure 50-20-2

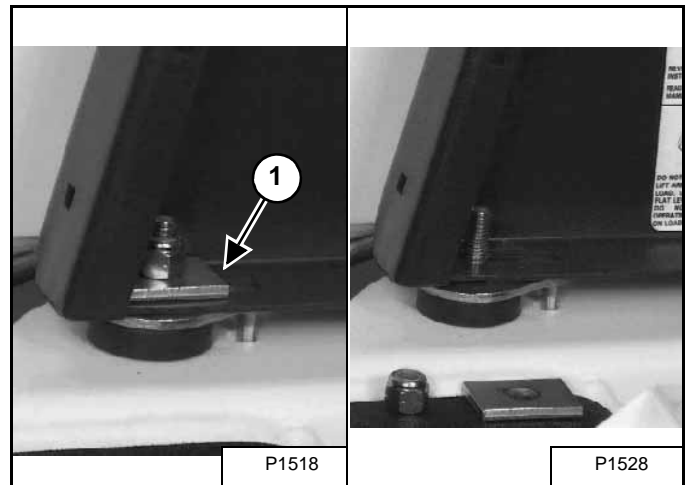

Remove the cab nut and holddown plate (Item 1) [Figure 50-20-2] (both sides).

**Installation:** Tighten the nut to 40-50 ft.-lbs. (54-68 Nm) torque.

Figure 50-20-3



Install a strap (Item 1) [Figure 50-20-3] to the cab handles to prevent the cab from falling forward.

Raise the operator cab (See Raising The Operator Cab on Page 10-30-1.), to release the tension on the gas cylinder.

## OPERATOR SEAT (SUSPENSION) (CONT'D)

### Cushion Removal And Installation (Cont'd)

Figure 50-31-9

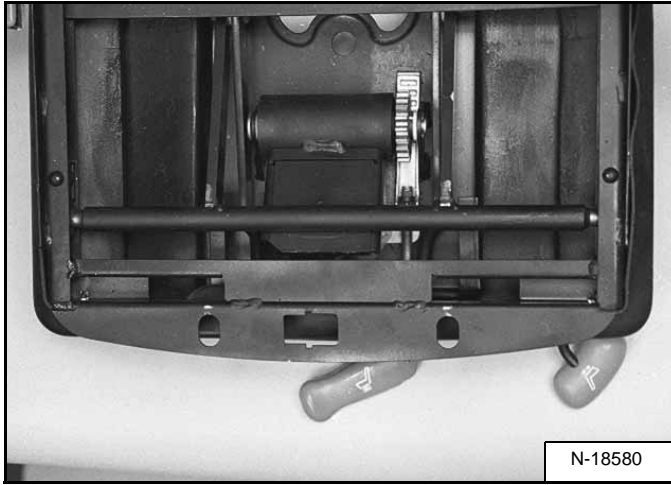

Inspect the seat ride adjustment [Figure 50-31-9].

Reverse the removal procedure to install the operator seat back.

### Back Removal And Installation

Figure 50-31-10

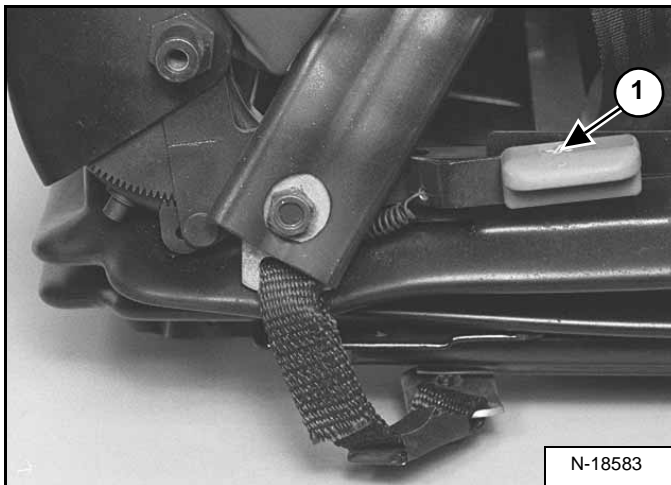

Pull the seat back adjustment lever (Item 1) [Figure 50-31-10] and tilt the seat back all the way forward.

Figure 50-31-11

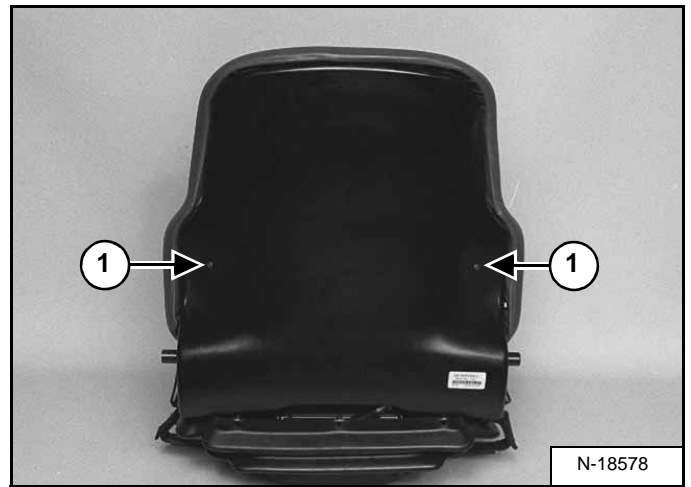

Remove the two mounting screws (Item 1) [Figure 50-31-11] from the seat back and remove the back.

Reverse the removal procedure to install the operator seat back.

## LIFT ARM

### Removal And Installation

Figure 50-50-1



Roll the Bob-Tach fully forward. Stop the engine.

Remove the Bob-Tach frame from the lift arms. (See Removal And Installation on Page 50-40-1.)

Install jackstands under the rear of the loader [Figure 50-50-1].

Figure 50-50-2

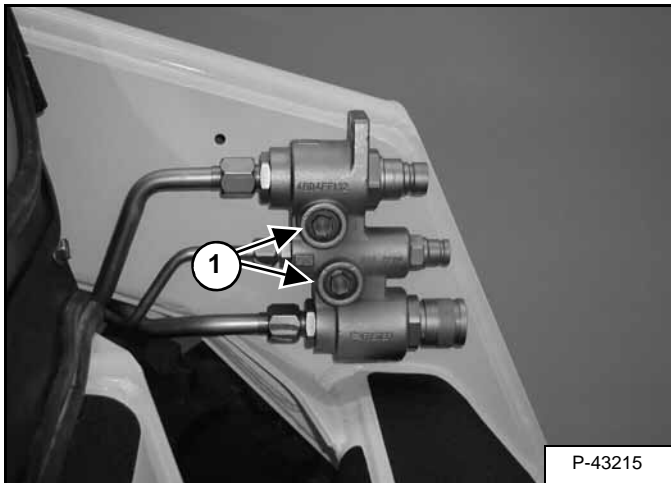

Remove the front auxiliary mount mounting bolts (Item 1) [Figure 50-50-2].

Figure 50-50-3

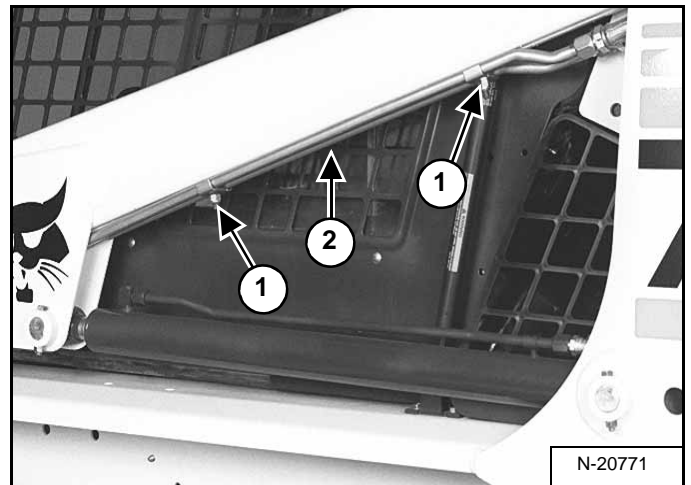

Remove the tubeline clamps (Item 1) [Figure 50-50-3] under the lift arms.

Pull the tubelines (Item 2) [Figure 50-50-3] down .

CLICK HERE TO **DOWNLOAD** THE COMPLETE MANUAL

- Thank you very much for reading the preview of the manual.
- You can download the complete manual from: [www.heydownloads.com](http://www.heydownloads.com) by clicking the link below



- Please note: If there is no response to CLICKING the link, please download this PDF first and then click on it.

CLICK HERE TO **DOWNLOAD** THE COMPLETE MANUAL

## REAR DOOR (CONT'D)

### Door Latch and Catch Adjustment

# WARNING

## AVOID INJURY OR DEATH

Never service or adjust the machine when the engine is running unless instructed to do so in the manual.

W-2012-0497

Figure 50-70-7

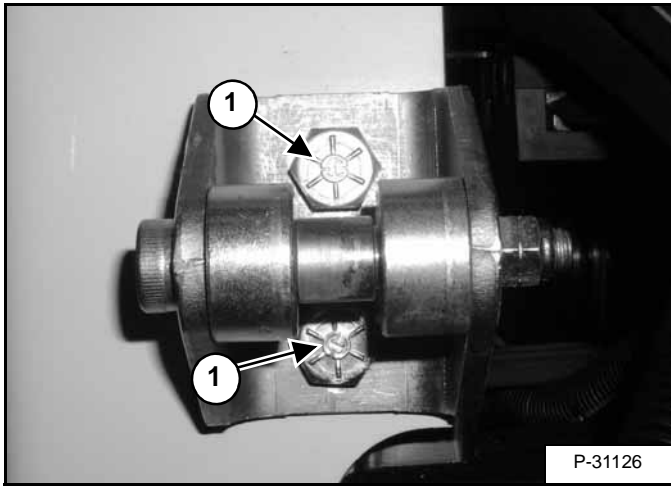

Loosen the striker assembly mount bolts (Item 1) [Figure 50-70-7].

Align the striker assembly in the center of the mounting holes.

**NOTE:** Tighten the striker assembly, top mount bolt only, until it will hold the striker assembly in the center of the mounting slots.

Figure 50-70-8

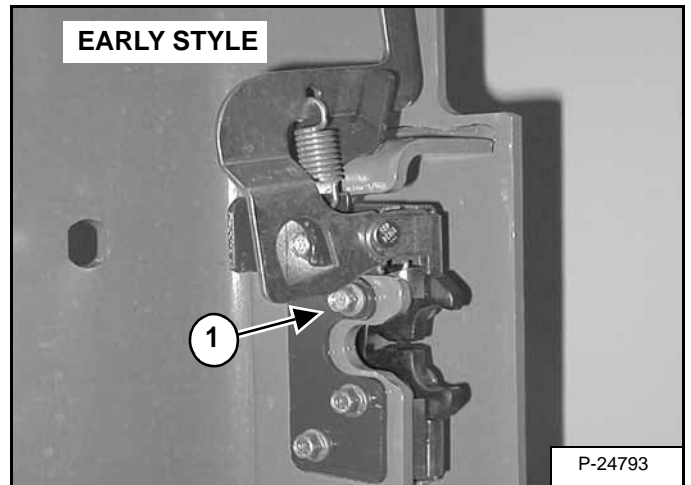

On early style loaders, (*S/N 515840618 and Below*) the tailgate latch can be adjusted also. Loosen the four attaching bolts (Item 1) [Figure 50-70-8], adjust the latch and then retighten to 80-90 in.-lbs. (9-10 Nm) torque. Later style loaders do not have an adjustment here.

Close the rear door. (This will align the striker assembly to the correct position.)

Open the door.

Tighten both striker mount bolts (Item 1) [Figure 50-70-7].

Close the rear door.

## CONTROL PANEL

### Removal and Installation

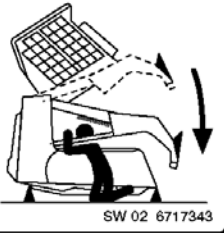
<b>⚠ DANGER</b>	
<b>AVOID DEATH</b> <ul style="list-style-type: none"><li>• Disconnecting or loosening any hydraulic tubeline, hose, fitting, component or a part failure can cause lift arms to drop.</li><li>• Keep out of this area when lift arms are raised unless supported by an approved lift arm support. Replace if damaged. 57051</li></ul>	

SW 02 6717343

**⚠ WARNING**

Never work on a machine with the lift arms up unless the lift arms are secured by an approved lift arm support device. Failure to use an approved lift arm support device can allow the lift arms or attachment to fall and cause injury or death.

W-2059-0598

**⚠ WARNING**

Put jackstands under the front axles and rear corners of the frame before running the engine for service. Failure to use jackstands can allow the machine to fall or move and cause injury or death.

W-2017-0286

Raise the lift arms and install an approved lift arm support device. (See Installing Lift Arm Support Device on Page 10-20-1.)

Raise the operator cab. (See Raising The Operator Cab on Page 10-30-1.)

Remove the engine speed control. (See Removal And Installation on Page 70-20-1.)

Figure 50-100-1

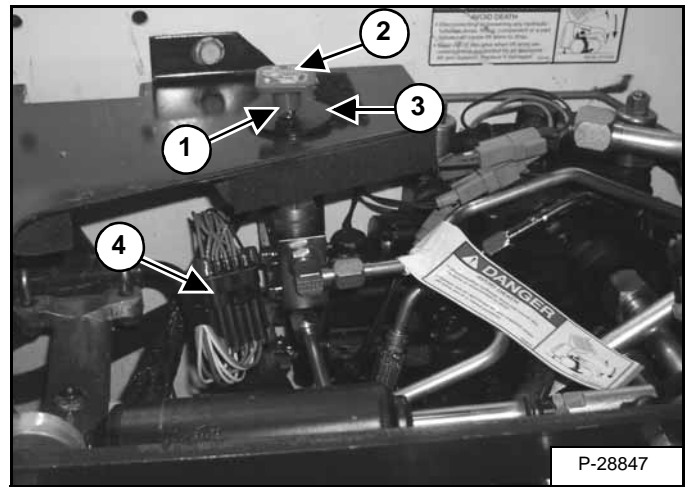

Loosen the jam nut (Item 1) from the by-pass control knob. Remove the control knob (Item 2) jam nut (Item 1) and rubber washer (Item 3) [Figure 50-100-1] from control panel.

Disconnect the control harness connectors (Item 4) [Figure 50-100-1] from the right side control lever.

**NOTE:** If the loader is equipped with front auxiliary hydraulics, also disconnect the electrical connectors from the left side control lever.

## CONTROL HANDLE (CONT'D)

### Linkage Adjustment (Cont'd)

Figure 50-110-19

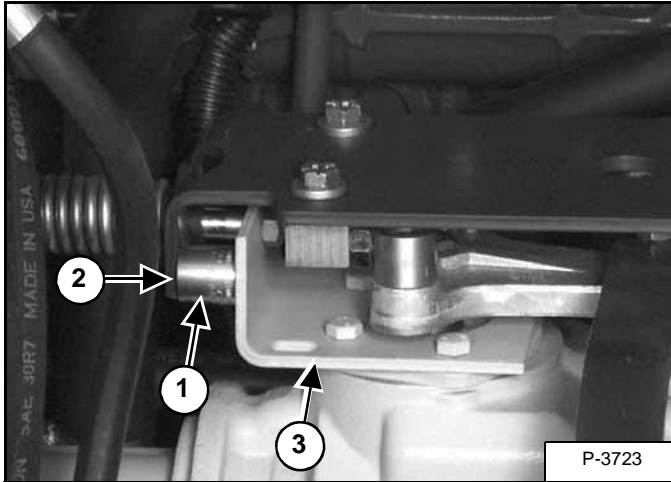

Move the right side steering lever forward and install a 15/16 inch (24 mm) thick spacer (Item 1) between the center plate (Item 2) and the mounting plate (Item 3) [Figure 50-110-19].

This will allow the pintle arms to move freely while adjusting the steering linkage for full forward travel speed.

Remove the 3/8 inch (10 mm) thick spacer (Item 1) [Figure 50-110-18].

Figure 50-110-20

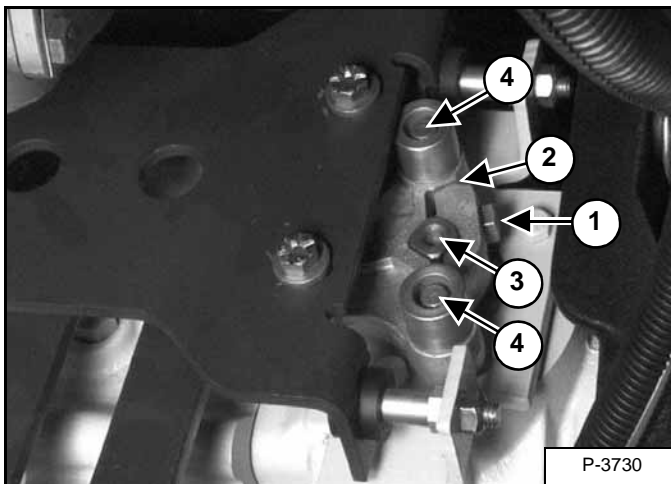

Before adjusting the linkage, check that the pintle arm mounting bolt (Item 1) is tight, 25-28 ft.-lbs. (34-38 Nm) torque and that there is no play between the pintle arm (Item 2) and the square pump shaft (Item 3). Also check that the cam mounting bolts (Item 4) [Figure 50-110-20] are tight, 45-50 ft.-lbs. (62-68 Nm) torque.

Figure 50-110-21

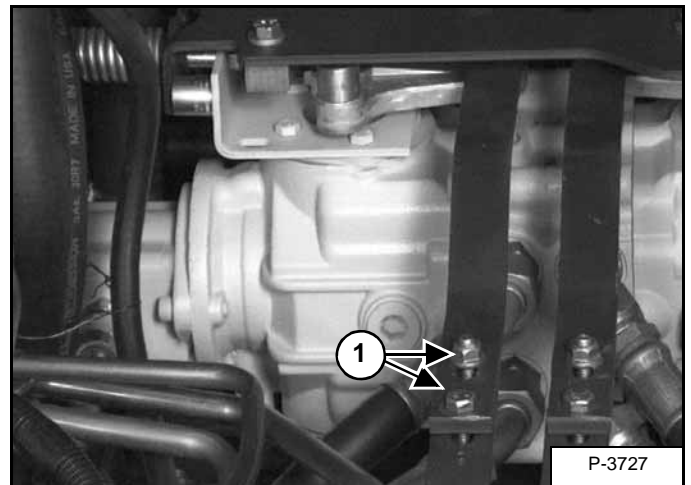

Loosen the two bolts and nuts (Item 1) [Figure 50-110-21] on each steering linkage bar.

Figure 50-110-22



Move the left control lever to the full forward position, then pull forward on the left rear linkage bar until the pintle arm is rotated to the front as far as possible [Figure 50-110-22]. Use a locking plier and clamp the two linkage bars together.

**Installation:** Tighten the nuts and bolts to 25-28 ft.-lbs. (34-38 Nm) torque.

Check the lever movement to make sure that the pintle arm and the control lever are both at full stroke at the same time. This will allow for maximum forward speed.

Repeat the procedure for the right side linkage.

## CONTROL HANDLE (ADVANCED HAND CONTROL) (AHC) (CONT'D)

### Control Lever Boot

Figure 50-111-18

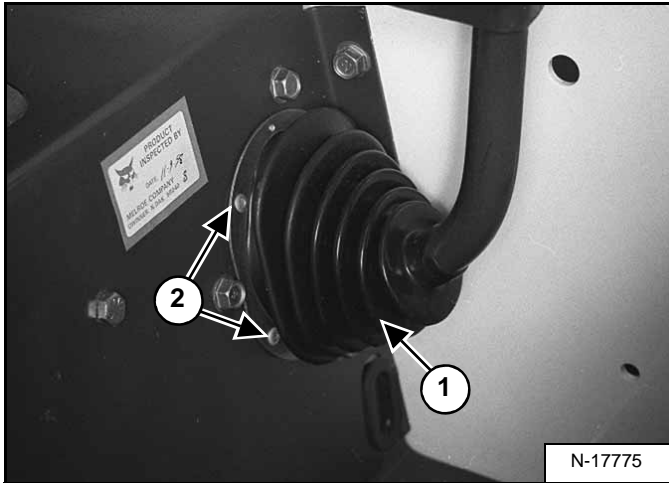

To replace the rubber boot (Item 1) **[Figure 50-111-18]** on the control panel, remove the control lever. (See Control Lever Removal And Installation on Page 50-111-6.)

Drill out the four rivets (Item 2) **[Figure 50-111-18]** located on the flange of the rubber boot and remove the old boot.

Install the new boot and reinstall the control lever. (See Control Lever Removal And Installation on Page 50-111-6.)

**CONTROL HANDLE (ADVANCED CONTROL SYSTEM) (ACS) ADVANCED HAND CONTROL (CONT'D)**

**Handle Sensor Removal And Installation (Cont'd)**

**Figure 50-113-8**

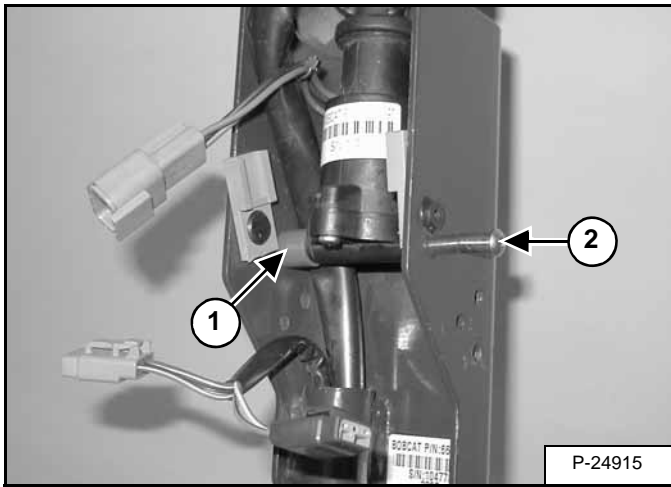

**Figure 50-113-9**

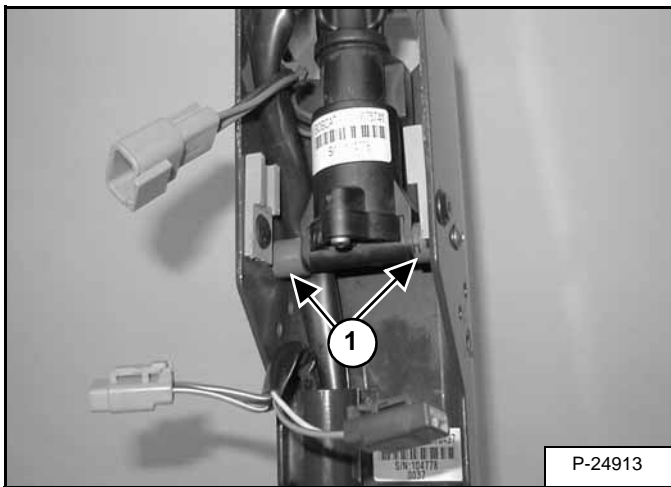

Remove the spacers (Item 1) [Figure 50-113-8] & [Figure 50-113-9] while removing the mounting pin (Item 2) [Figure 50-113-8].

**EARLIER VERSION HAND CONTROLS ONLY;**

**Figure 50-113-10**

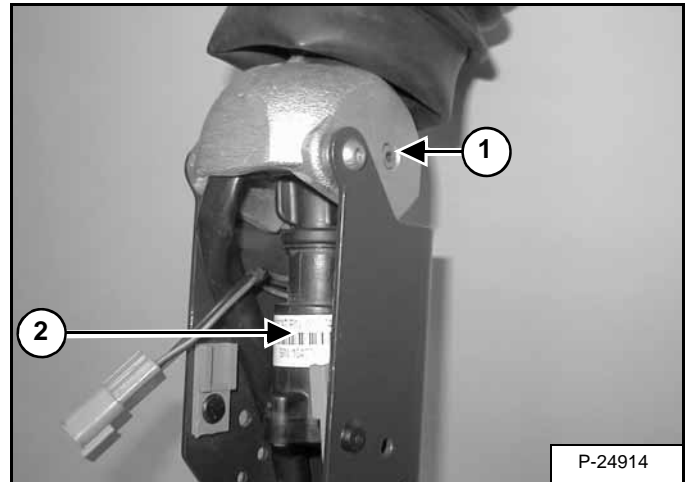

Remove the mounting bolt and nut (Item 1) [Figure 50-113-10] from the control handle and shaft.

**NOTE:** Be careful not to loose the recessed nut on the other side of the handle.

Remove the handle sensor (Item 2) [Figure 50-113-10] from the control handle.

**Installation:** Tighten the mounting bolt to 32-38 in.-lbs (3,6-4,3 Nm) torque.

**Figure 50-113-11**

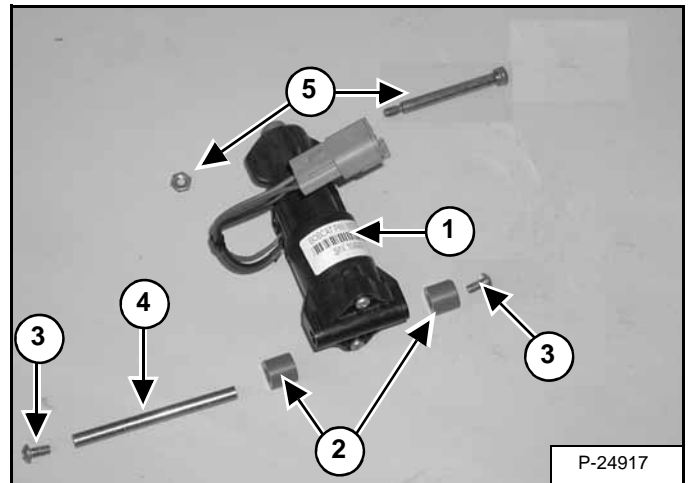

**NOTE:** The handle sensor (Item 1) [Figure 50-113-11] can only be replaced as a complete assembly.

Check the spacers (Item 2), screws (Item 3), mounting pin (Item 4), bolt/nut (Item 5) [Figure 50-113-11] and replace as needed.

**CONTROL HANDLE (ADVANCED CONTROL SYSTEM) (ACS) SELECTABLE HAND/FOOT CONTROL (CONT'D)**

**Control Handle Removal and Installation**

**Figure 50-114-15**

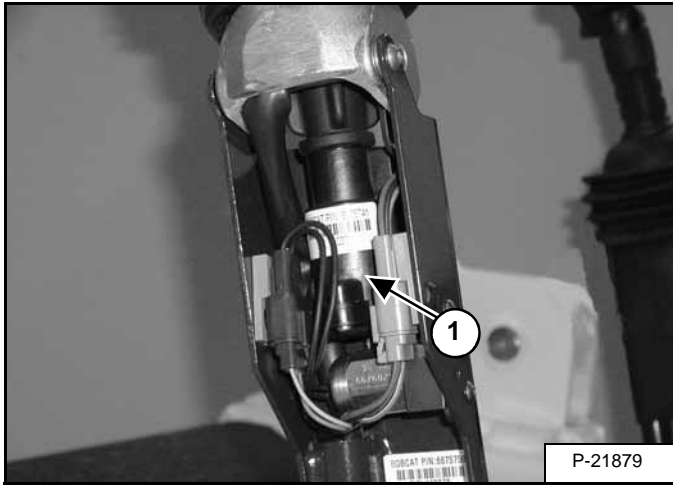

Remove the handle sensor (Item 1) [Figure 50-114-15]. (See Handle Sensor Connector on Page 60-123-5.)

**Figure 50-114-16**

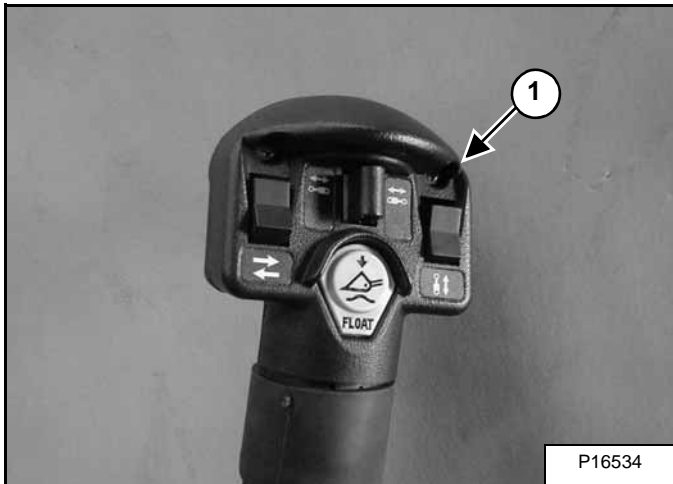

Remove the switch handle (Item 1) [Figure 50-114-16]. (See Switch Handle Removal on Page 60-123-6.)

**Figure 50-114-17**

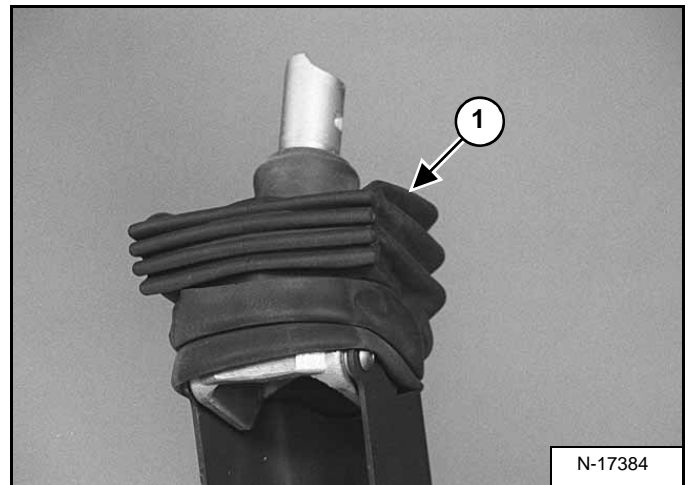

Remove the rubber handle cover (Item 1) [Figure 50-114-17] from the handle.

**Figure 50-114-18**

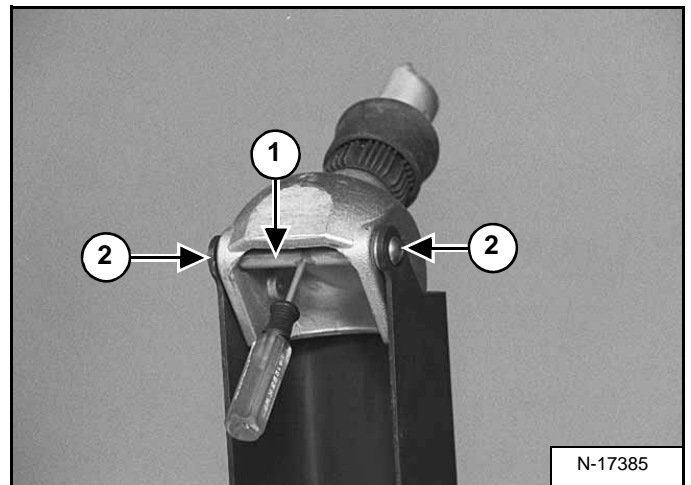

Using a small screwdriver, hold the handle spacer (Item 1) and remove the allen head screws (Item 2) [Figure 50-114-18] from the handle assembly.

**Installation:** Tighten the allen head screws to 35 in.-lbs. (4 Nm) torque.

# 753 WIRING SCHEMATIC (Without ACS Option)

S/N 515835000 - 515834999  
S/N 516222000 - 516221999  
(PRINTED APRIL 2003)  
V-0128

RED = RED  
RNG = ORANGE  
BLK = BLACK  
LBL = LIGHT BLUE  
DBL = DARK BLUE  
LGN = LIGHT GREEN  
DGN = DARK GREEN  
YEL = YELLOW  
PNK = PINK  
WHT = WHITE  
BRN = BROWN  
TAN = TAN  
PUR = PURPLE  
GRY = GRAY

WIRES CONNECT BY  
LETTER ACROSS  
CONNECTORS  
SOME CONNECTOR  
BODIES NOT SHOWN  
FOR DRAWING CLARITY

SEE FUSE/RELAY  
CENTER  
(EUROPEAN  
LIGHTING)  
THIS PAGE.

BATTERY FEED 1000-1999 RED, RED/WHT, RNG  
GROUND 2000-2999 BLK  
MONITORING 3000-3999 LBL  
HYDRAULIC 4000-4999 LGN  
ATTACHMENT CONTROLS 5000-5999 YEL  
LIGHTS 6000-6999 PNK  
ACCESSORIES 7000-7999 WHT  
ENGINE 8000-8999 TAN  
COMMUNICATION 9000-9999 PUR

\* NOTE: THESE ARE NOT  
FOUND ON ALL  
MACHINES.

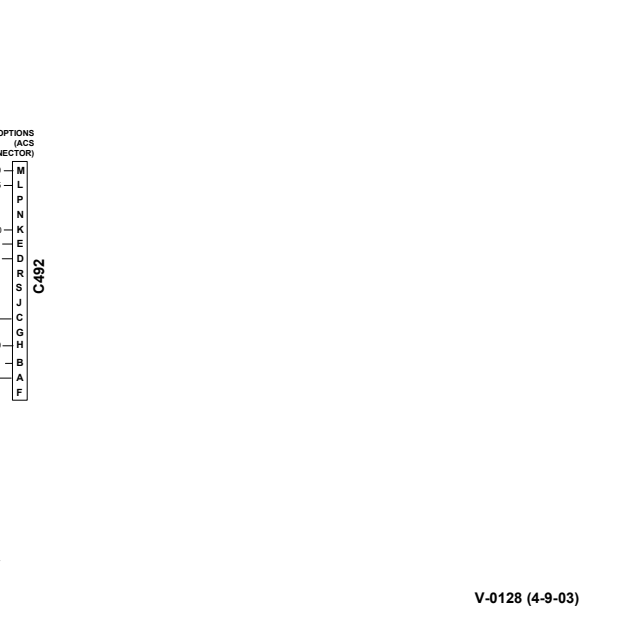
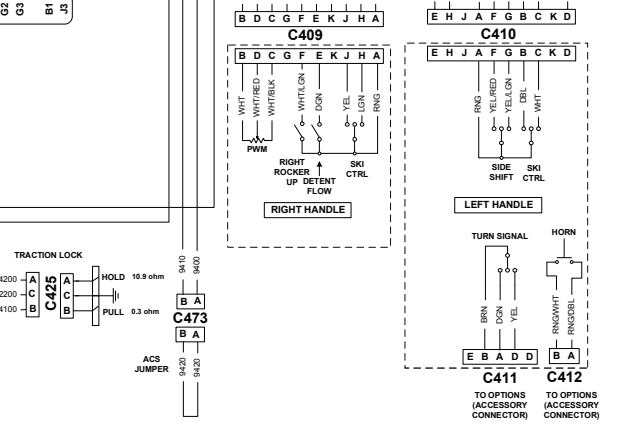
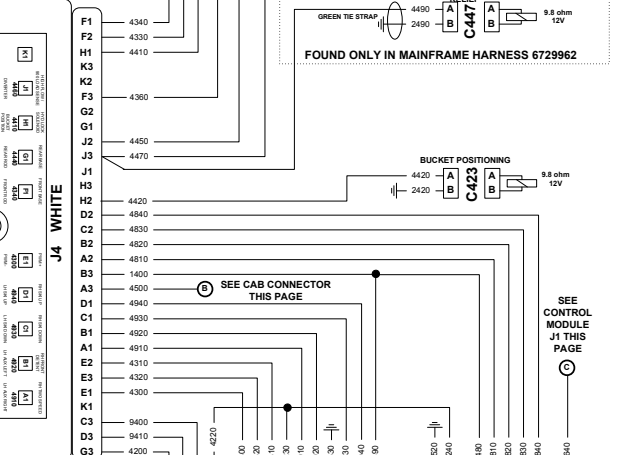
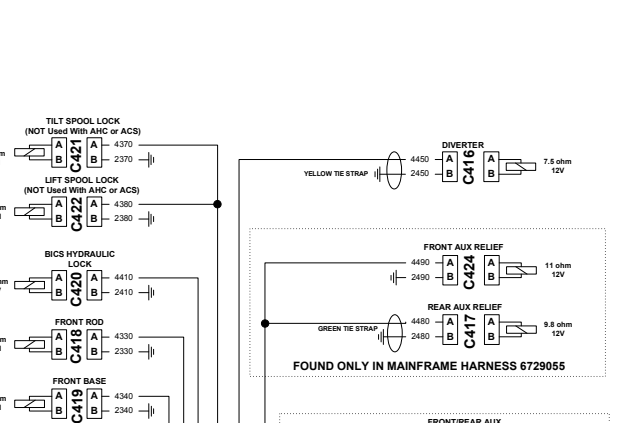
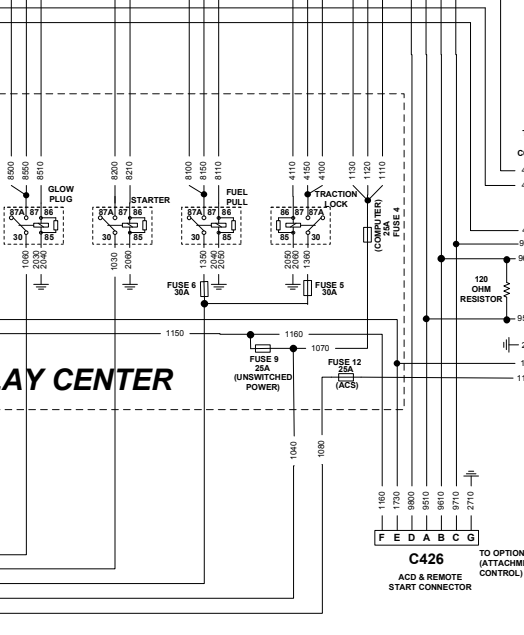
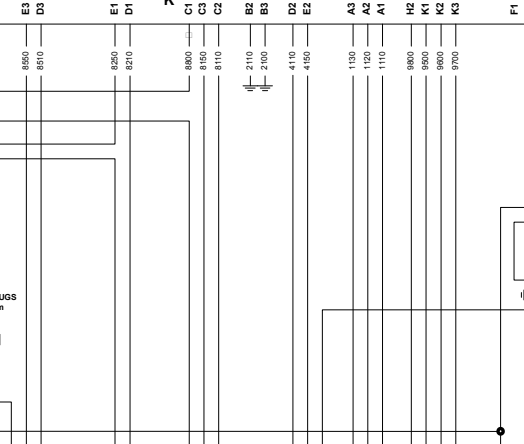
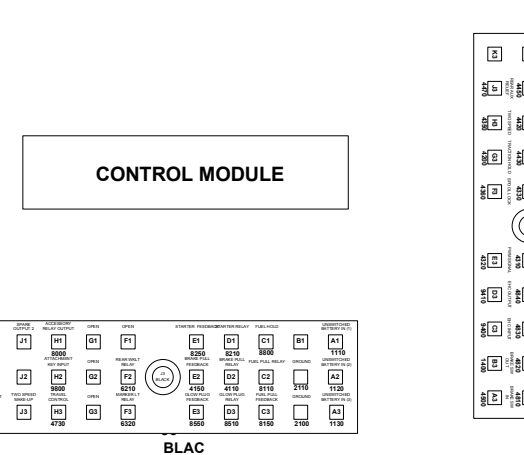
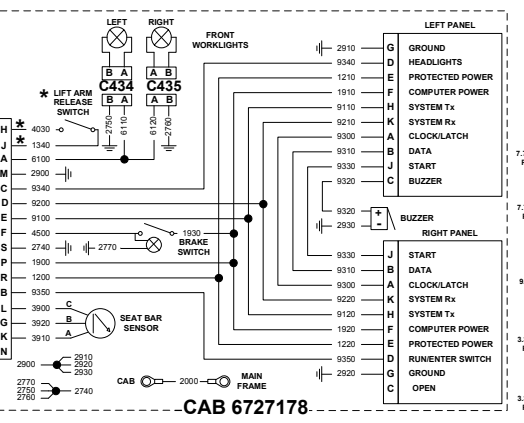
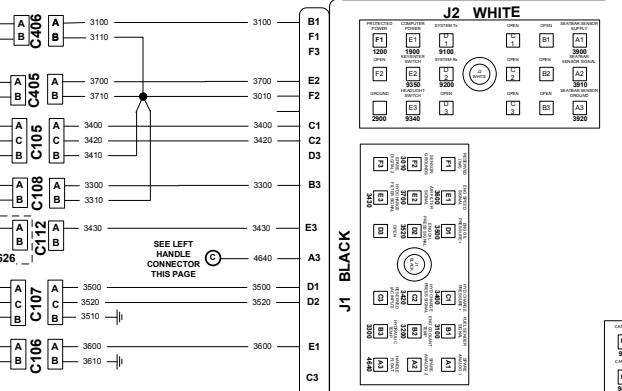
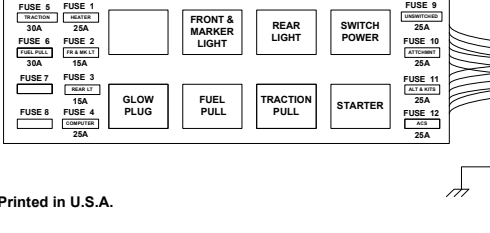
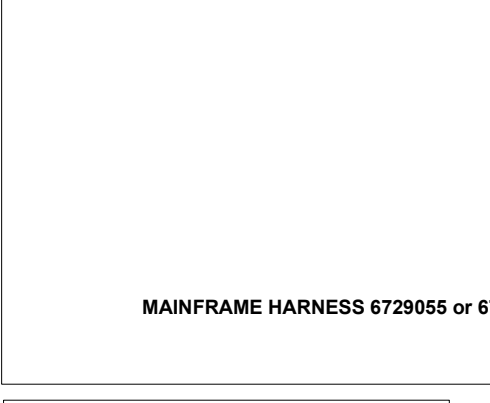
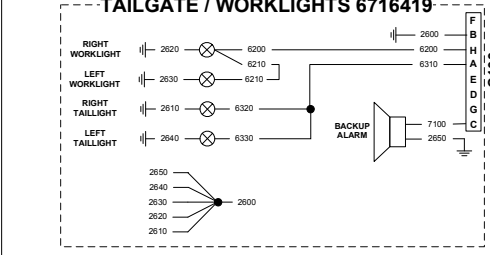
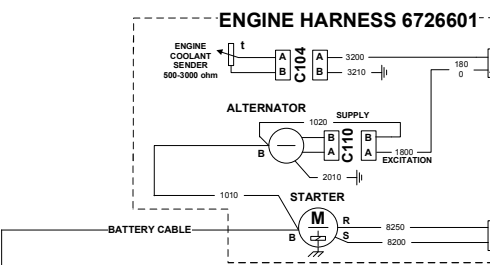
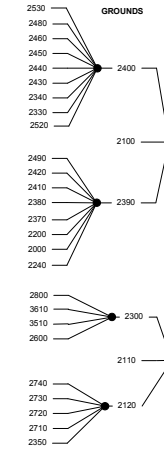

**OPTIONS**

**753 WIRING SCHEMATIC  
OPTIONS  
(S/N 515820001 & Above)  
(S/N 516220001 & Above)  
(PRINTED APRIL 2003)  
V-0129**

**753 WIRING SCHEMATIC  
OPTIONS  
(S/N 515830001 & Above)  
(S/N 516220001 & Above)  
(PRINTED APRIL 2003)  
V-0130**

**753 WIRING SCHEMATIC  
OPTIONS  
(S/N 515830001 & Above)  
(S/N 516220001 & Above)  
(PRINTED APRIL 2003)  
V-0131**

**753 WIRING SCHEMATIC  
OPTIONS  
(S/N 515835000-515836424)  
(S/N 516220000-516222355)  
(PRINTED APRIL 2003)  
V-0132**

**753 WIRING SCHEMATIC  
OPTIONS  
(S/N 515836425 & Above)  
(S/N 516222356 & Above)  
(PRINTED APRIL 2003)  
V-0133**

## ALTERNATOR (55 AMP) (CONT'D)

### Rectifier (Diode) Test

Figure 60-30-3

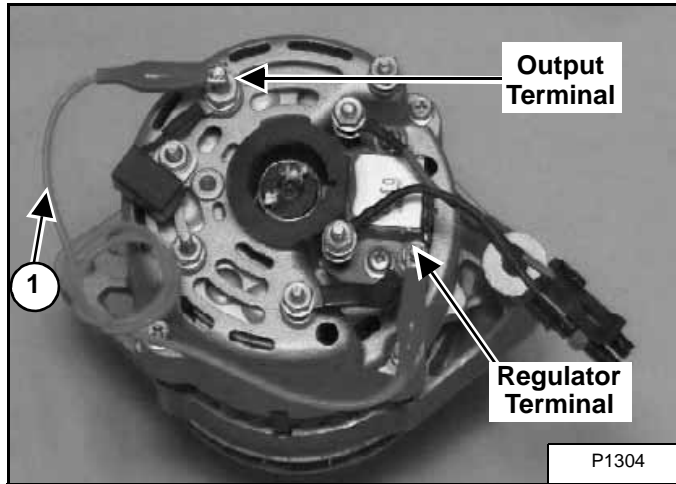

The alternator is removed from the loader for clarity purposes [Figure 60-30-3].

Disconnect the negative (-) cable from the battery.

Install the wires in their original location on the back of the alternator.

Connect a jumper wire (Item 1) [Figure 60-30-3] to the alternator output terminal and the regulator terminal.

Connect the battery negative (-) cable.

Start the engine and run at 2600 RPM.

If the reading is within 45-55 amps. at 2600 RPM replace the rectifier (diode) assembly or replace the alternator.

If the reading is low, do the Alternator Regulator Test.

## Alternator Regulator Test

### WARNING

When an engine is running in an enclosed area, fresh air must be added to avoid concentration of exhaust fumes. If the engine is stationary, vent the exhaust outside. Exhaust fumes contain odorless, invisible gases which can kill without warning.

W-2050-1285

Figure 60-30-4

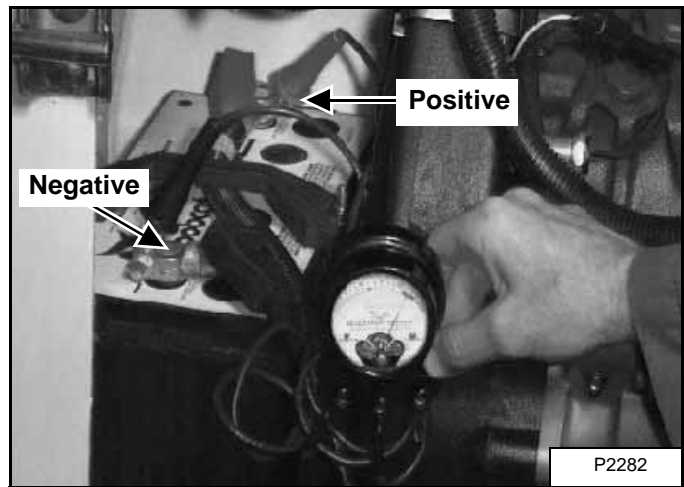

Connect the positive (+) voltmeter lead to the positive (+) battery terminal [Figure 60-30-4].

Connect the negative (-) voltmeter lead to the negative (-) battery terminal [Figure 60-30-4].

Start the engine and run at 1500-2000 RPM.

The voltmeter should read between 13.9-14.7 volts.

If the reading is low stop the engine and disconnect the battery negative (-) cable.

## ALTERNATOR (90 AMP) (CONT'D)

### Low Voltage Test (Cont'd)

Figure 60-31-7

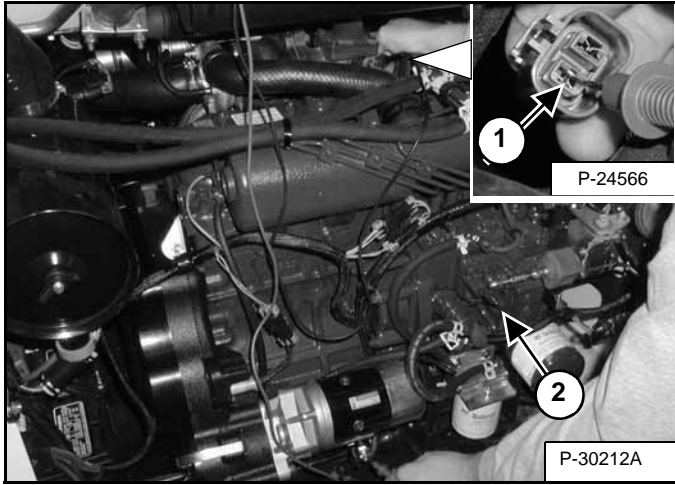

Check the voltage across the “L” terminal (Item 1) and ground (Item 2) [Figure 60-31-7]. The voltage should be what the battery voltage is. If not, check wire harness, relay and fuses. If the wire harness, relay and fuses are ok then remove alternator for replacement or repair. To repair, (See Removal And Installation on Page 60-31-5.)

### High Voltage Test

Figure 60-31-8

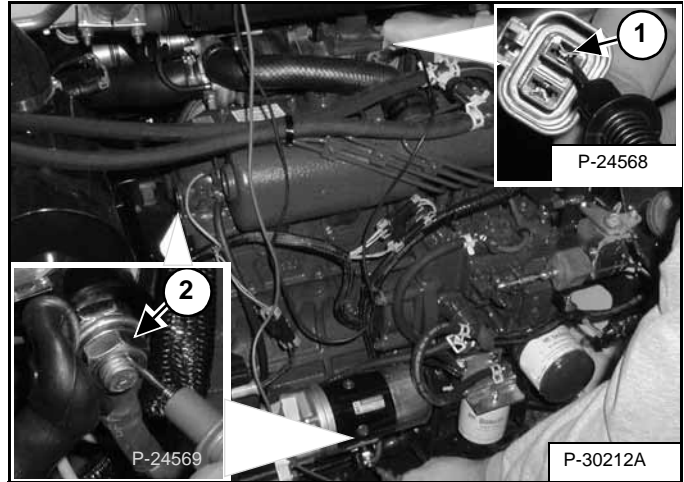

Turn engine OFF and remove the L & S Terminal connector (Item 1) [Figure 60-31-6] off the alternator.

Check the continuity between the “S” terminal (Item 1) and the positive (+) terminal on the battery or starter terminal (Item 2) [Figure 60-31-8]. There should be continuity. If no continuity, replace wire harness.

If voltage is still above 14.7 volts at 70°F (Alternator Temperature), then remove alternator for replacement or repair. To repair, (See Removal And Installation on Page 60-31-5.)

## STARTER (NIPPONDENSO) (CONT'D)

### Disassembly

Figure 60-40-5

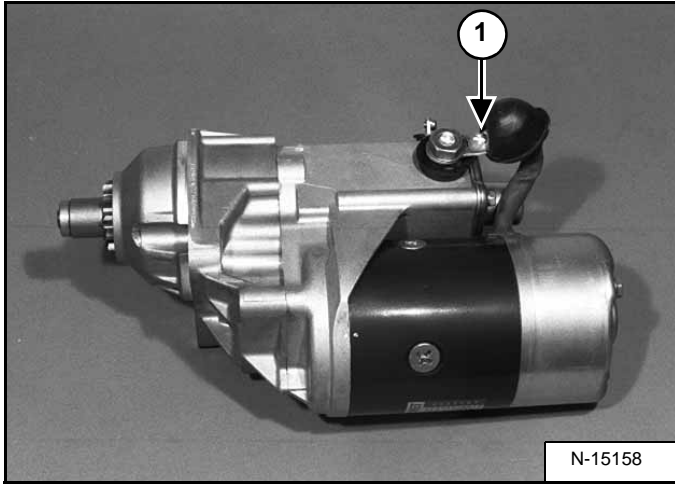

Remove the cable (Item 1) [Figure 60-40-5] from the magnetic switch.

Figure 60-40-6

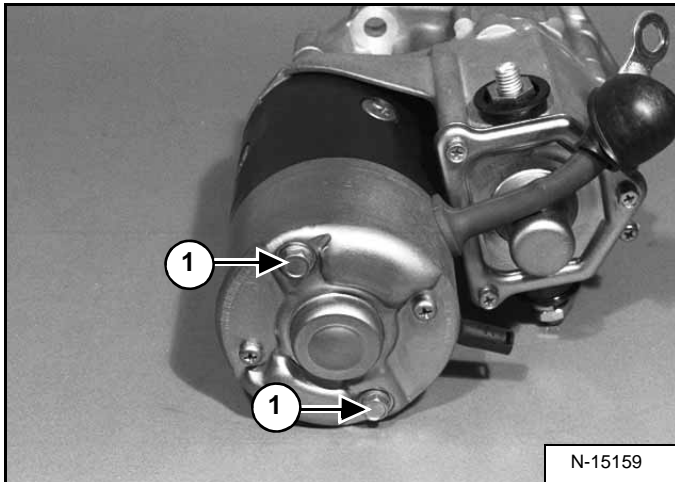

Remove the bolts (Item 1) [Figure 60-40-6].

Figure 60-40-7

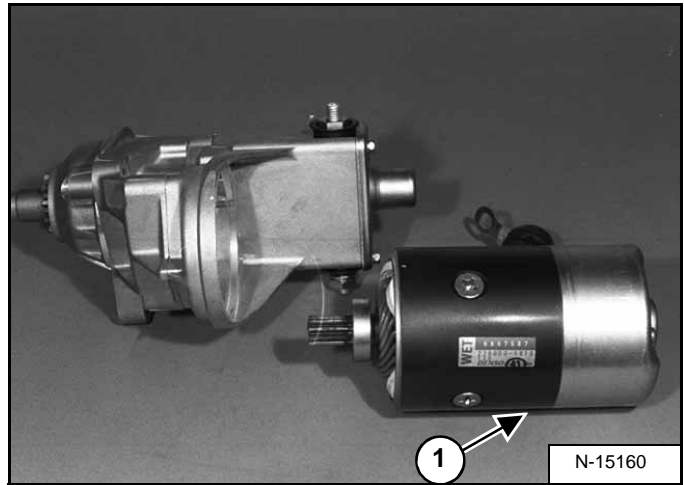

Remove the frame (Item 1) [Figure 60-40-7] from the magnetic switch.

Figure 60-40-8

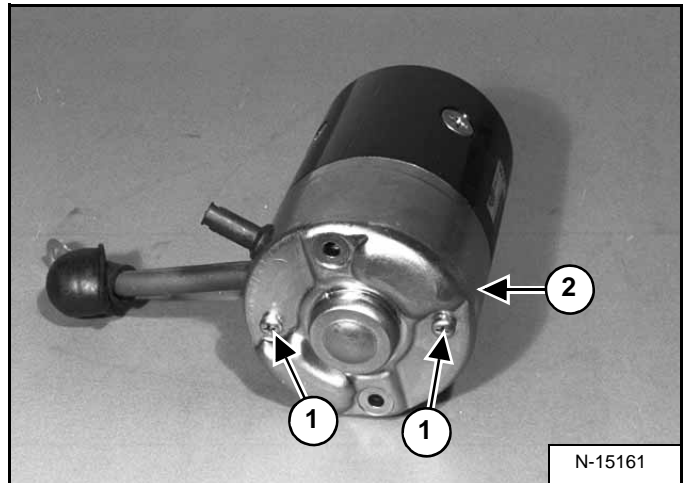

Remove the bolts (Item 1) from the brush cover (Item 2) [Figure 60-40-8].

Remove the cover (Item 2) [Figure 60-40-8].

## STARTER (NIPPONDENSO) (CONT'D)

### Assembly (Cont'd)

Figure 60-40-44

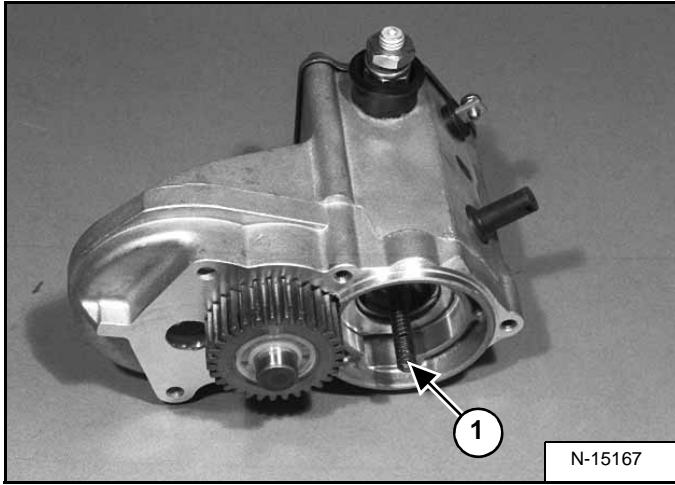

Install the spring (Item 1) [Figure 60-40-44] in the magnetic switch housing.

Figure 60-40-45

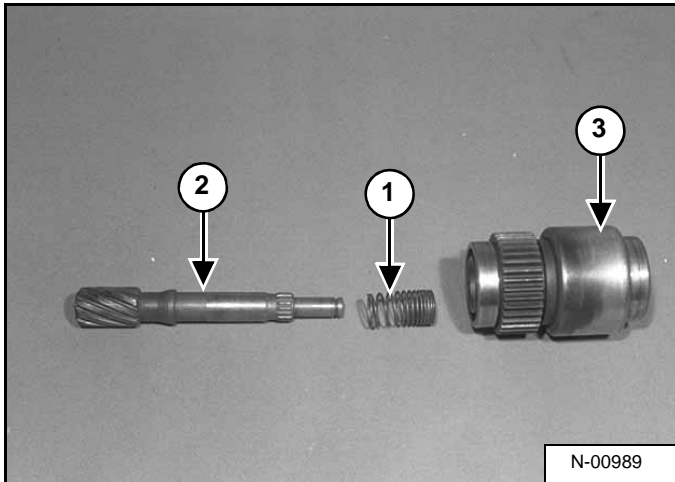

Install the spring (Item 1) over the pinion shaft (Item 2). Install the pinion shaft (Item 2) in the over running clutch (Item 3) [Figure 60-40-45].

Stand the clutch assembly on end.

Figure 60-40-46

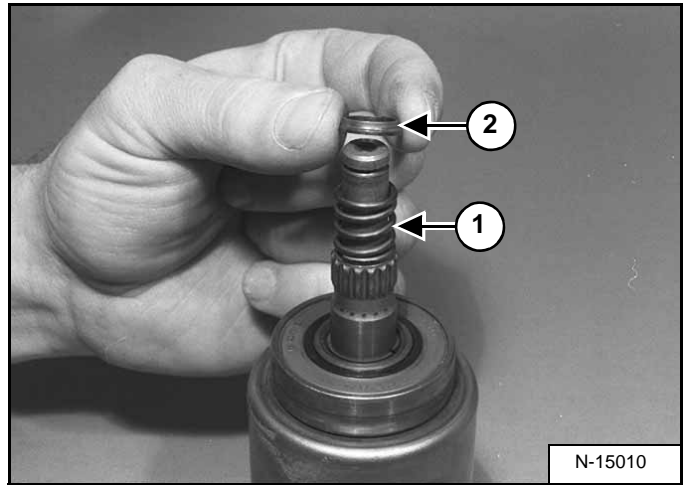

Install the spring (Item 1) and spring seat (Item 2) [Figure 60-40-46] on the pinion shaft.

Figure 60-40-47

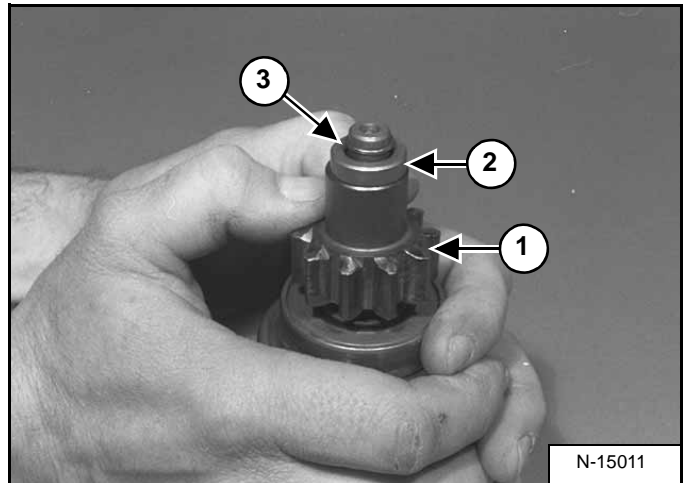

Install the pinion (Item 1) and retainer (Item 2) [Figure 60-40-47] on the pinion shaft.

Press down on the pinion (Item 1) and install the snap ring (Item 3) [Figure 60-40-47] on the pinion shaft.

Pull the retainer (Item 2) over the snap ring (Item 3) [Figure 60-40-47].

## STARTER (VALEO) (CONT'D)

### Disassembly and Assembly (Cont'd)

Figure 60-41-14

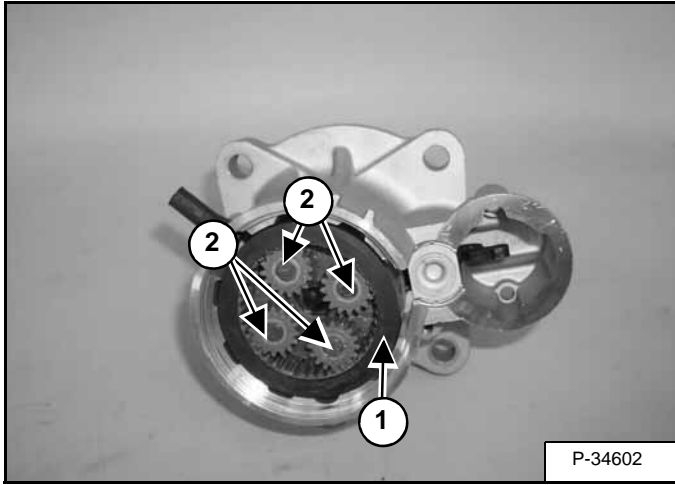

Remove the rubber retainer (Item 1) [Figure 60-41-14].

Remove the planetary gears (Item 2) [Figure 60-41-14] and inspect for damage.

Figure 60-41-15

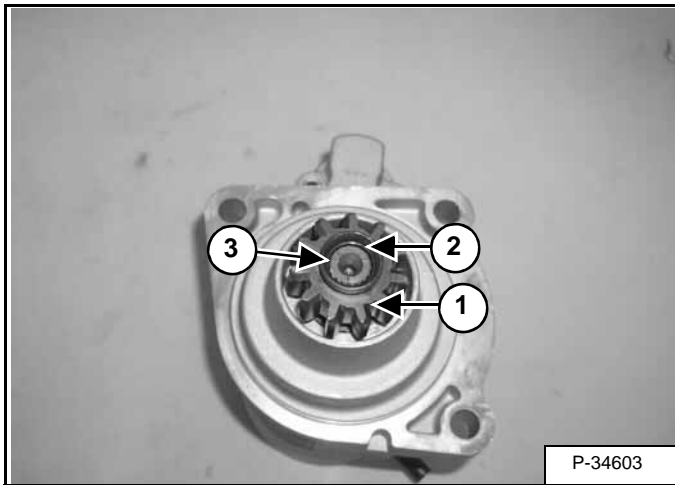

Press down on the pinion (Item 1) [Figure 60-41-15] & [Figure 60-41-16] and retainer (Item 2) [Figure 60-41-15] & [Figure 60-41-16].

Figure 60-41-16

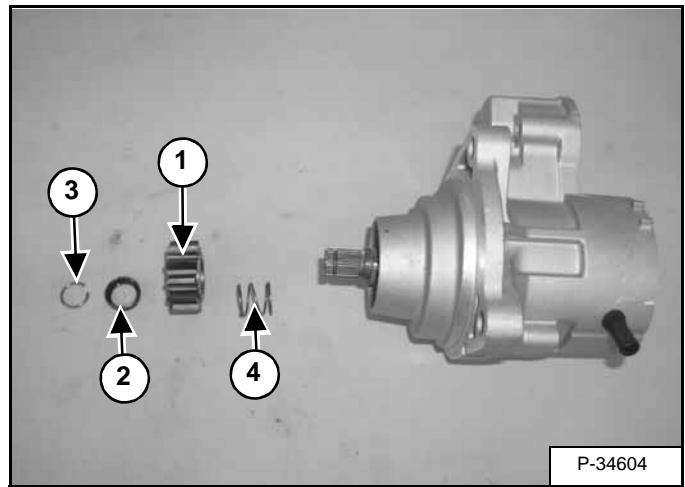

Remove the snap ring (Item 3) [Figure 60-41-15] & [Figure 60-41-16]

Remove the retainer (Item 2) [Figure 60-41-15] & [Figure 60-41-16] and pinion (Item 1) [Figure 60-41-15] & [Figure 60-41-16].

Remove the spring (Item 4) [Figure 60-41-16].

**Installation:** Inspect all parts for wear and replace as needed.

## INSTRUMENT PANEL (CONT'D)

### Right Panel Setup Display Options (Deluxe) (Cont'd)

All new machines with Deluxe Instrumentation arrive at Bobcat Dealerships with the panel in locked mode. This means that a password must be used to start the engine.

### Passwords

For security purposes, your dealer may change the password and also set it in the locked mode. Your dealer will provide you with the password.

**Owner Password:** Allows for the full use of the loader and to setup the Deluxe Panel. Owner can select a password to allow starting & operating the loader and modify the setup if the Deluxe Panel. Owner should change the password as soon as possible for security of the loader.

**User Password:** Allows starting and operating the loader; cannot change password or any of the other setup features.

### Changing the Password (Cont'd)

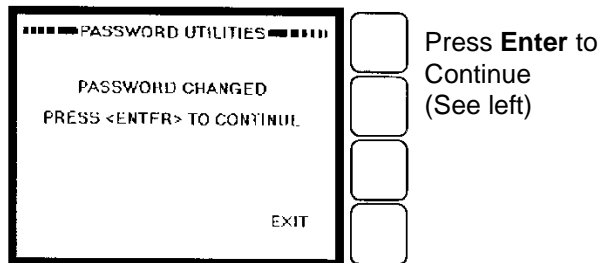
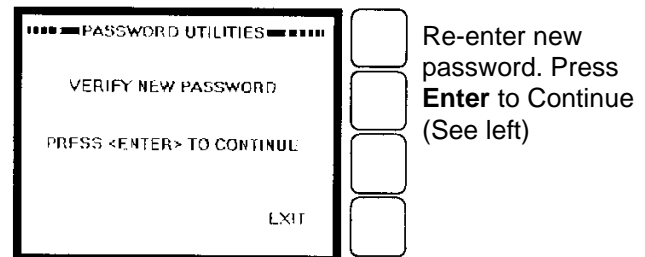
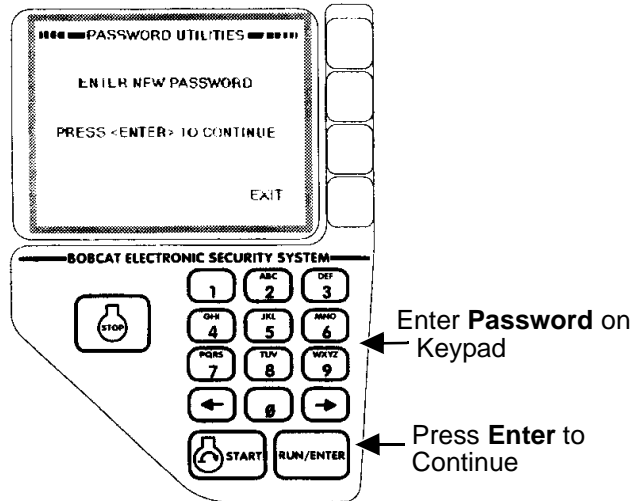

### More EXAMPLES:

**Clocks**  
**TOOL / SETUP**  
**LOADER FEATURES**  
**DISPLAY OPTIONS**  
**CLOCKS**  
**SET CLOCK**

Use the keypad to set time.  
 Press **RUN / ENTER** to set clock.  
 Press **EXIT** to return to previous level menu.  
**RESET JOB CLOCK** (Password required).  
 Press **CLEAR** to reset job clock to zero.  
 Press **LOCK / UNLOCK** to unlock.  
 Enter Password and press **RUN / ENTER**.

**Languages**  
**TOOL / SETUP**  
**LOADER FEATURES**  
**DISPLAY OPTIONS**  
**LANGUAGES**

Select the language, press **RUN / ENTER**.  
 Press **EXIT** to return to previous level menu.

### Changing the Password

### Right Instrument Pane Display Screen

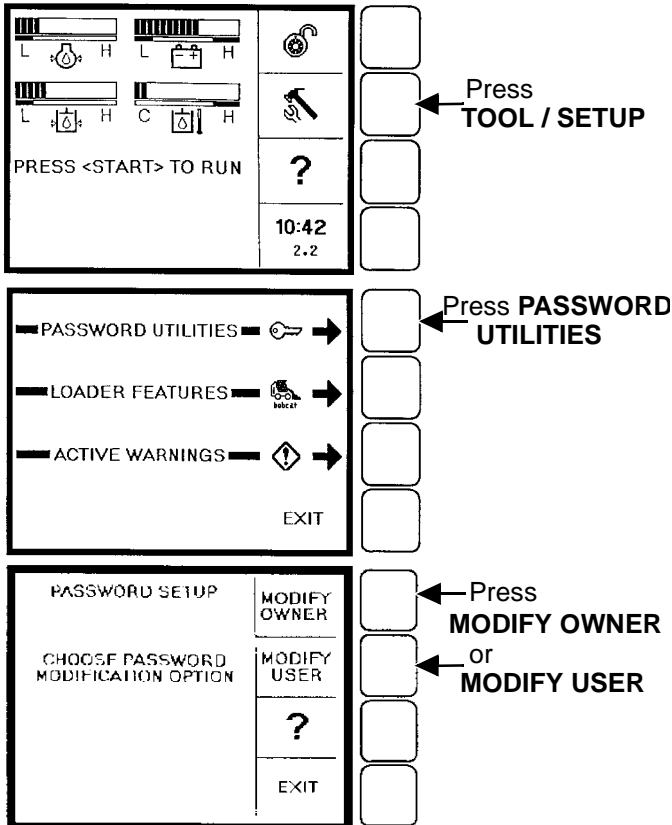

## BOBCAT CONTROLLER (CONT'D)

### Removal And Installation

# ! WARNING

Never work on a machine with the lift arms up unless the lift arms are secured by an approved lift arm support device. Failure to use an approved lift arm support device can allow the lift arms or attachment to fall and cause injury or death.

W-2059-0598

Lift and block the rear of the loader. (See LIFTING AND BLOCKING THE LOADER on Page 10-10-1.)

Raise the lift arms and install an approved lift arm support device. (See Installing Lift Arm Support Device on Page 10-20-1.)

Stop the engine. Raise the seat bar.

Raise the operator cab. (See Raising The Operator Cab on Page 10-30-1.)

Figure 60-70-1

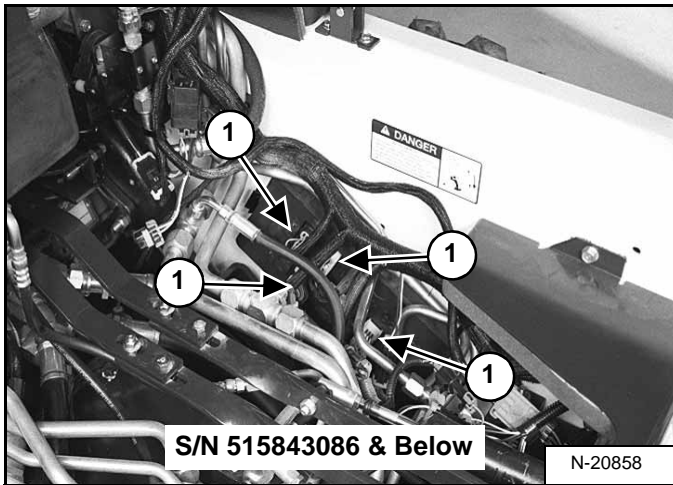
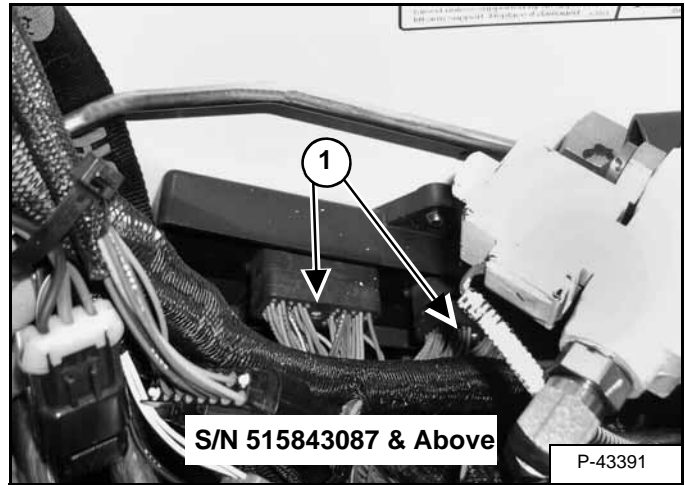

Figure 60-70-2



Loosen the connector mounting bolts (Item 1) [Figure 60-70-1] and [Figure 60-70-2] from the bobcat controller.

Remove the connectors.

**NOTE:** The connectors are keyed and will only plug in one way.

Figure 60-70-3

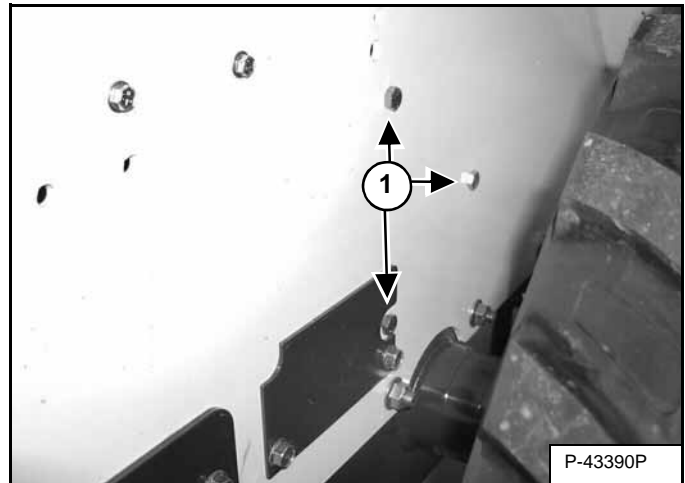

Remove the three mount bolts (Item 1) [Figure 60-70-3] of the system controller mounting bracket.

Remove the system controller.

**Installation:** Tighten the nuts to 25-28 ft.-lbs. (34-38 Nm) torque.

## SEAT BAR SENSOR (CONT'D)

### Test

Figure 60-100-1

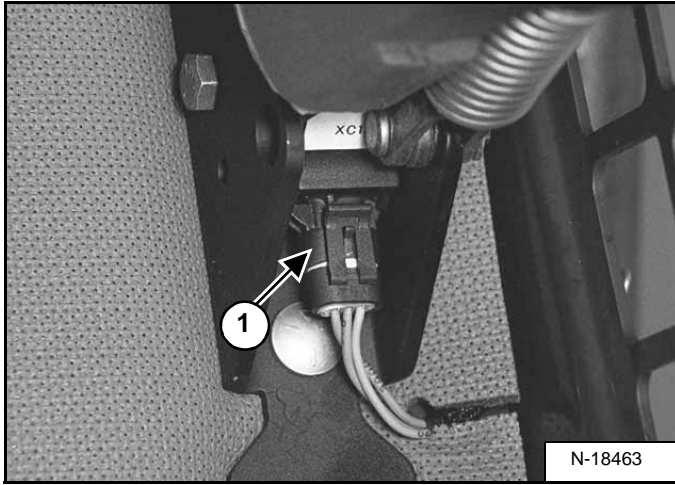

Use Sensor Tester (MEL1428) and seat bar sensor tester adapter (MEL1567) for the following procedure:

Connect the seat bar adapter sensor leads (MEL1567) to the sensor tester.

Disconnect the seat bar sensor connector (Item 1) [Figure 60-100-1].

Figure 60-100-2

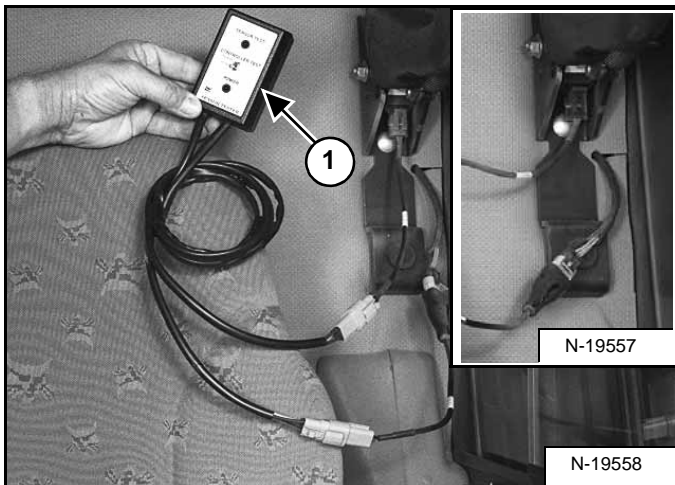

Connect the Sensor Tester (Item 1) inline, to the seat bar sensor connectors. See inset [Figure 60-100-2].

Turn the key to the ON position. **DO NOT START THE ENGINE.**

The toggle switch (Item 2) [Figure 60-100-3] can be in either the **Absent** or **Present** position.

Figure 60-100-3

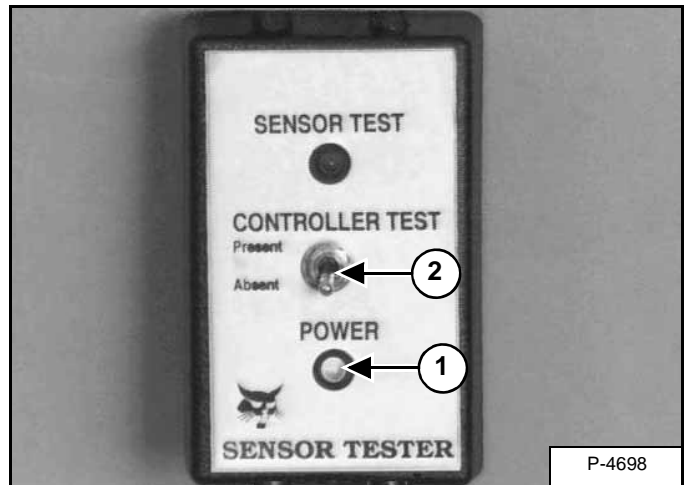

If there is no power light (Item 1) [Figure 60-100-3] on the sensor tester, check the tester or wiring harness.

Figure 60-100-4

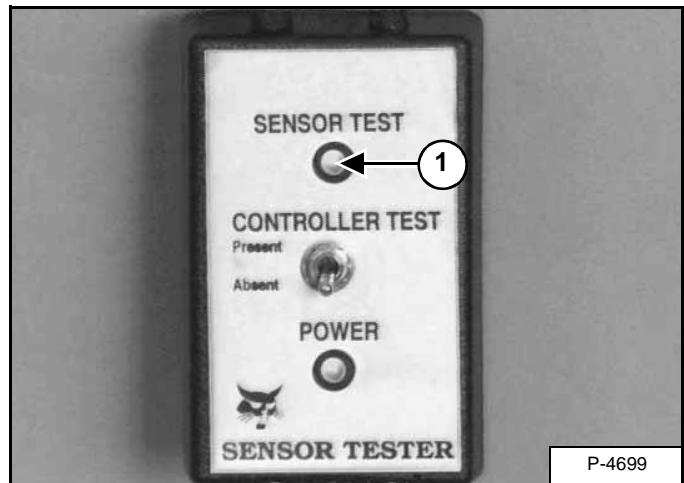

Lower the seat bar. The Sensor Test light (Item 1) [Figure 60-100-4] should illuminate.

Raise the seat bar. The Sensor Test light (Item 1) [Figure 60-100-4] should go off.

If the above test fails, there is a problem with the seat bar sensor.

Disconnect the Sensor Tester.

Replace the Seat Bar Sensor. (See Removal And Installation on Page 60-100-3.)

If the above test passes, run the seat bar sensor BICS circuit test. (See BICS™ Circuit Test on Page 60-100-4.)

## TRACTION LOCK (CONT'D)

### Guide Installation (Cont'd)

Figure 60-110-19

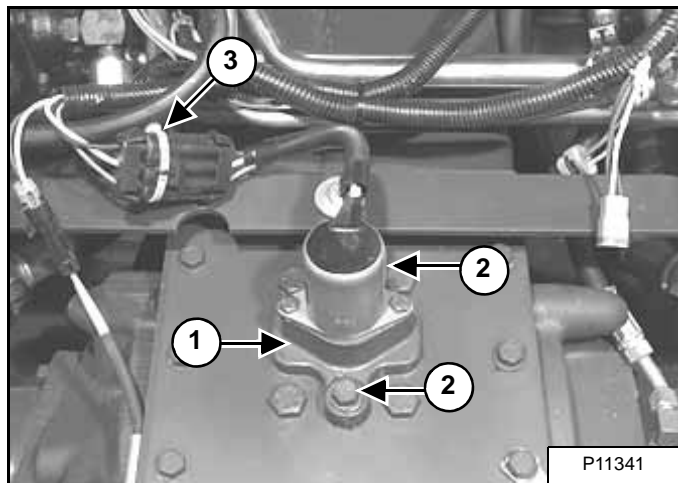

Install the solenoid mounting bracket assembly (Item 1) on the chaincase cover using the two bolts (Item 2) [Figure 60-110-19] and tighten to 25-28 ft.-lbs. (34-38 Nm) torque.

**NOTE:** Be sure the solenoid mounting bracket is installed in the same position. The solenoid mounting surface has a slight angle which tips the top of the solenoid toward the rear of the loader when installed correctly.

Install a new DO NOT MODIFY sta-strap (Item 3) [Figure 60-110-19] (P/N 6665527) on the electric solenoid connector.

Install the control panel. (See Removal and Installation on Page 50-100-1.)

Install the engine speed control. (See Removal And Installation on Page 70-20-1.)

Lower operator cab. (See Lowering The Operator Cab on Page 10-30-2.)

Perform the BICS™ inspection procedure. (See BICS™ SYSTEM on Page 60-90-1.)



**Bobcat®**

## ADVANCED HAND CONTROL (AHC) SYSTEM (W/ PUSH BUTTON FLOAT) (CONT'D)

### Actuators Disassembly And Assembly (Cont'd)

Figure 60-121-27

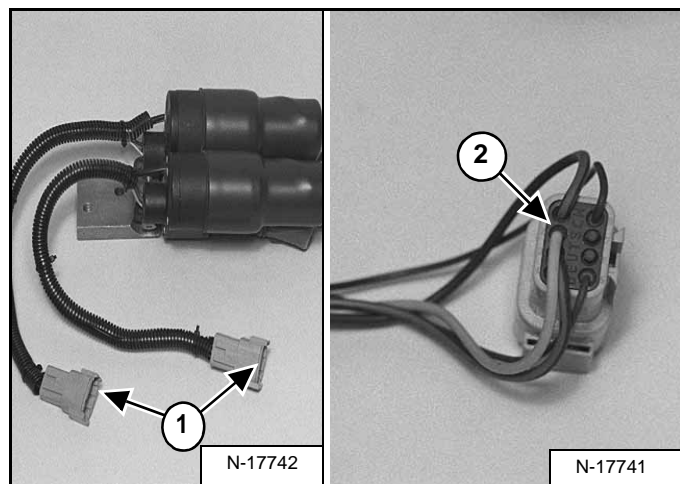

Check the actuator wiring harness connector (Item 1) [Figure 60-121-27] and replace if broken.

**Installation:** Install the wires into the connector as listed below. The terminal numbers are written on the back of the connector (Item 2) [Figure 60-121-27].

#### *Lift and Tilt Actuator*

- 1 - Terminal-Black/Green-Larger diameter wire (16 gauge)
- 2 - Terminal-Green-Larger diameter wire (16 gauge)
- 3 - Terminal-Red/Green-Larger diameter wire (16 gauge)
- 4 - Terminal-Open
- 5 - Terminal-Red-Smaller diameter wire (18 gauge)
- 6 - Terminal-Open
- 7 - Terminal-Open
- 8 - Terminal-Black-Smaller diameter wire (18 gauge)

## ADVANCED CONTROL SYSTEM (ACS) ADVANCED HAND CONTROL (CONT'D)

### Switch Handle Installation (Cont'd)

Figure 60-122-27

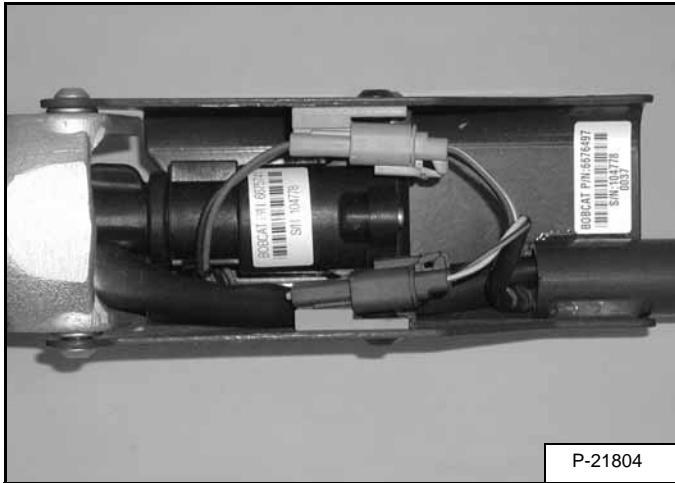

Connect the handle harness connector to the sensor and blank handle connector [Figure 60-122-27].

### Actuators Disassembly And Assembly

Figure 60-122-28

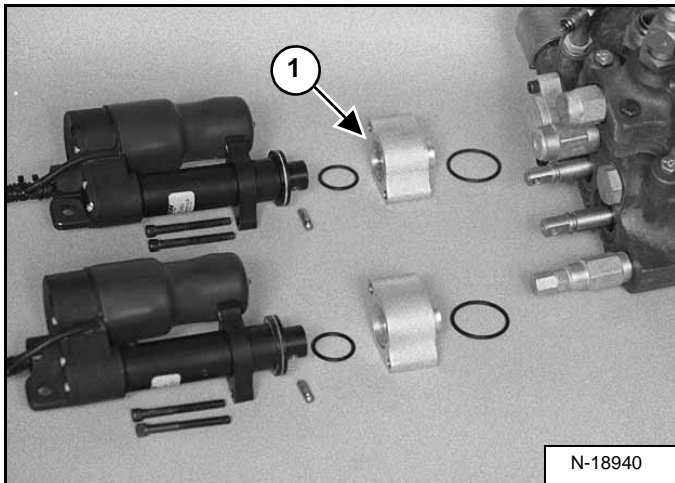

Remove the actuator from the hydraulic control valve. (See Actuator Removal And Installation on Page 20-41-8.)

Check the mounting block (Item 1) [Figure 60-122-28] and bolts for wear and replace as needed.

Figure 60-122-29

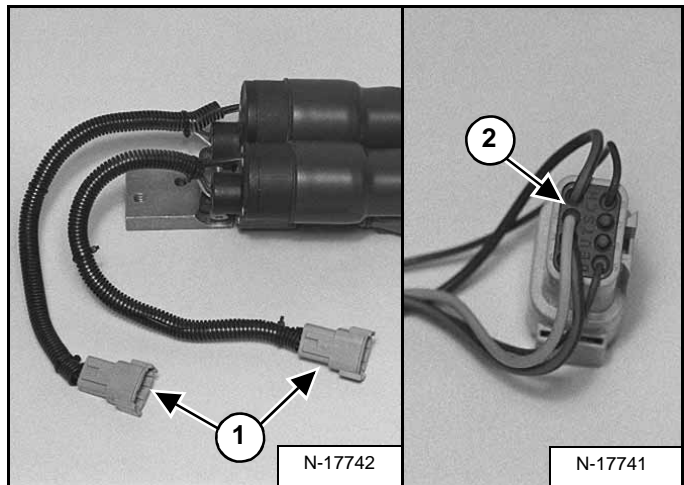

Check the actuator wiring harness connector (Item 1) [Figure 60-122-29] and replace if broken.

**Installation:** Install the wires into the connector as listed below. The terminal numbers are written on the back of the connector (Item 2) [Figure 60-122-29].

#### Lift and Tilt Actuator

- 1 - Terminal-Black/Green-Larger diameter wire (16 gauge)
- 2 - Terminal-Green-Larger diameter wire (16 gauge)
- 3 - Terminal-Red/Green-Larger diameter wire (16 gauge)
- 4 - Terminal-Open
- 5 - Terminal-Red-Smaller diameter wire (18 gauge)
- 6 - Terminal-Open
- 7 - Terminal-Open
- 8 - Terminal-Black-Smaller diameter wire (18 gauge)

## ADVANCED CONTROL SYSTEM (ACS) SELECTABLE HAND/FOOT CONTROL (CONT'D)

### Switch Handle Installation (Cont'd)

Figure 60-123-24

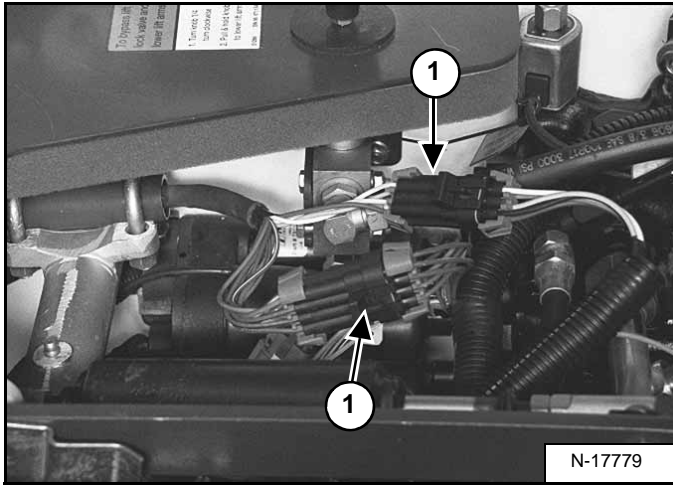
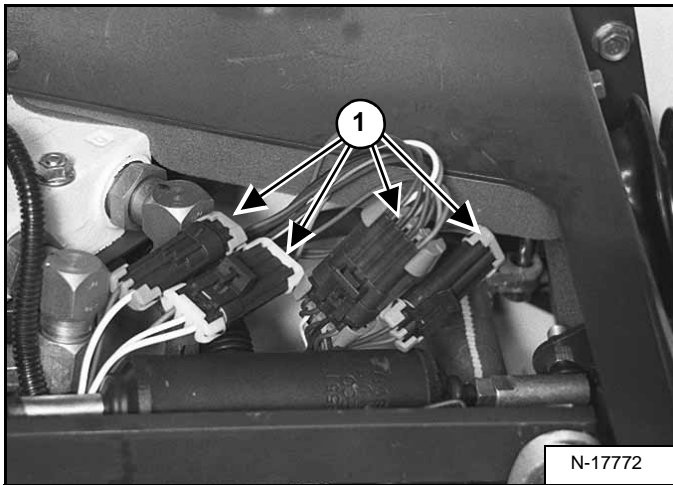

Figure 60-123-25



Connect the handle harness connectors (Item 1) [Figure 60-123-24] & [Figure 60-123-25] to the loader harness connectors.

Install the wires into the connector as listed below:

Figure 60-123-26

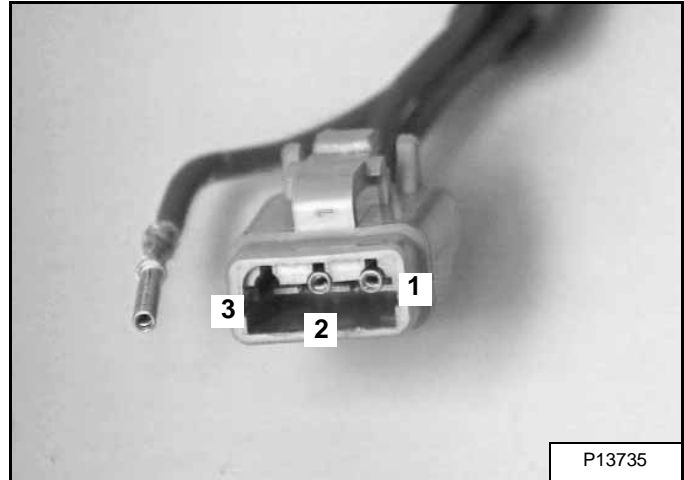

Left and Right Control Lever Switch Handle [Figure 60-123-26]

- 1-Terminal - Red/White
- 2-Terminal - Black/White
- 3-Terminal - Purple/White

Figure 60-123-27

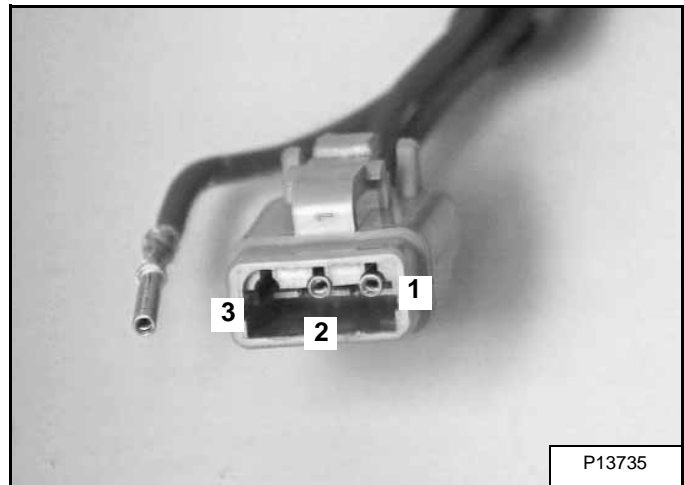

Left and Right Control Lever Switch Handle [Figure 60-123-27]

- 1-Terminal - Yellow/Red
- 2-Terminal - Open
- 3-Terminal - Orange/Black



**Bobcat®**



**Bobcat®**

# COOLING FAN (CONT'D)

## Gearbox Parts Identification

- 1. Seal
- 2. Snap Ring (Small)
- 3. Shims (1.0 inch O.D.)
- 4. Bearing
- 5. Shaft (Long)
- 6. Shims (2.0 inch O.D.)
- 7. Long Key
- 8. Shaft (Short)
- 9. Short Key
- 10. Long Housing
- 11. Nut
- 12. Gear
- 13. Washer
- 14. Screw
- 15. Square Shim
- \*16. Short Housing
- 17. Bolt
- 18. Snap Ring (Large)
- 19. Cap
- 20. Long Housing Assy.
- 21. Short Housing Assy.
- 22. Fill Plug

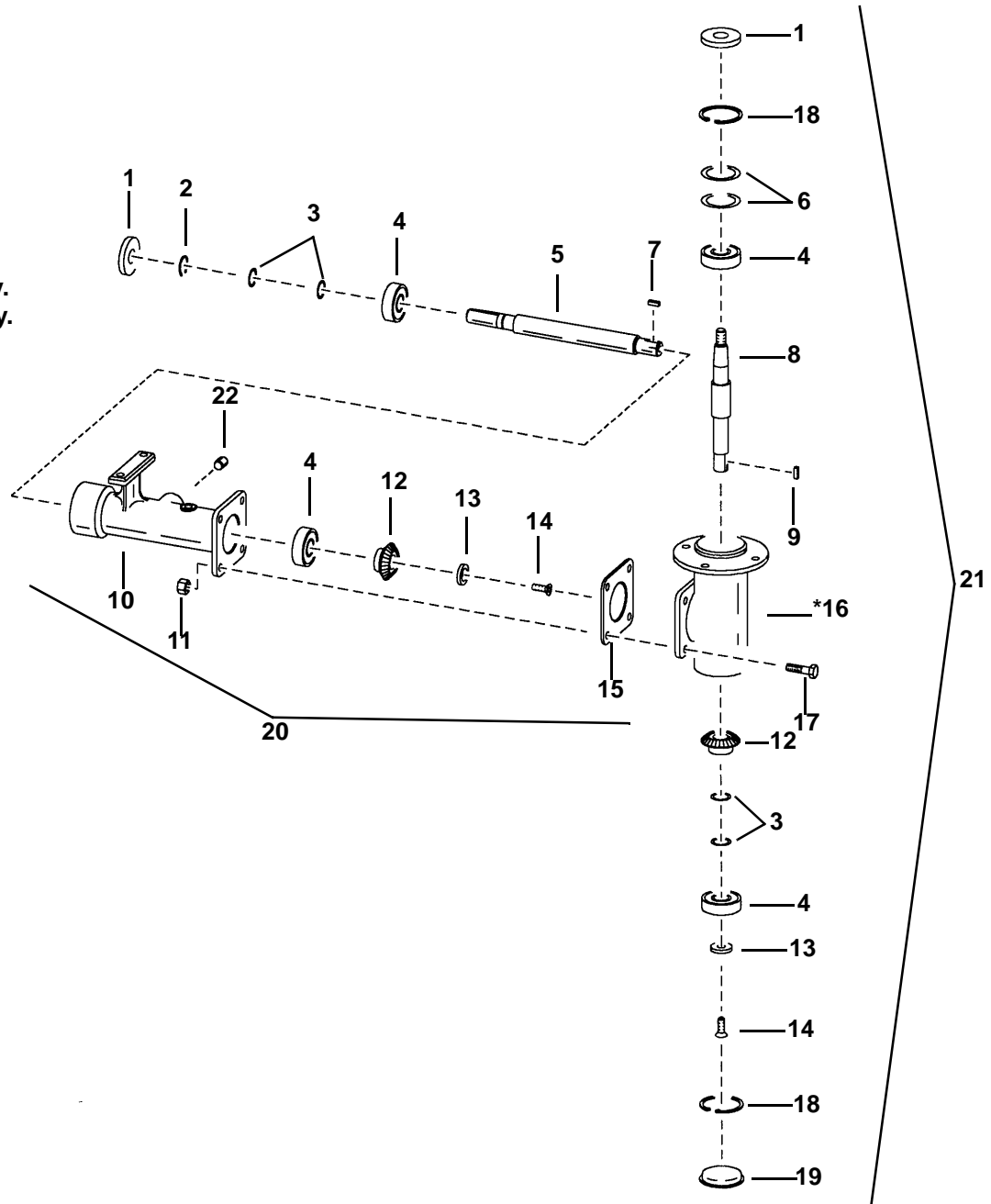

\* Individual Part not available. (See Note Page 70-60-7.)

TS-1002A

## COOLING FAN (CONT'D)

### Gearbox Assembly (Cont'd)

Figure 70-60-52

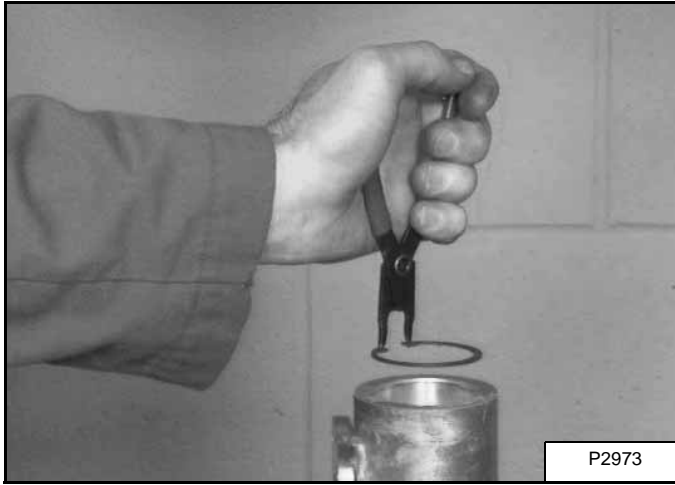

Install the snap ring in the groove above the bearing [Figure 70-60-52].

Figure 70-60-53

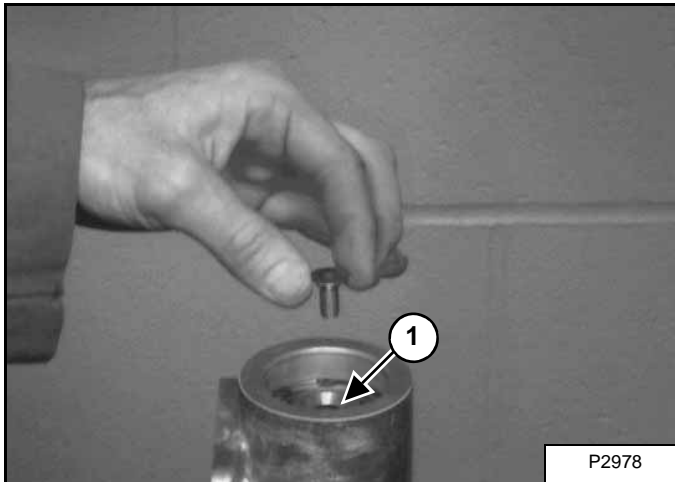

Install the washer (Item 1) on the shaft. Put liquid adhesive (LOCTITE #242) on the screw threads and install the screw [Figure 70-60-53].

### Gearbox Checking Backlash

**NOTE:** For procedures requiring the use of LOCTITE #242 adhesive, thoroughly clean and dry affected parts before the application of LOCTITE #242.

The backlash tolerance between the gears should be 0.005-0.008 inch (0,127-0,203 mm).

To check the gear backlash use the following procedure:

Figure 70-60-54

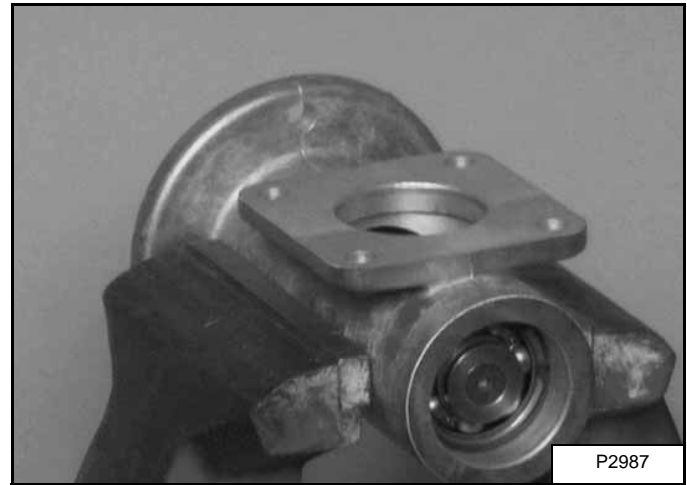

Put the short housing in a vise, square flange facing up as shown [Figure 70-60-54].

Figure 70-60-55

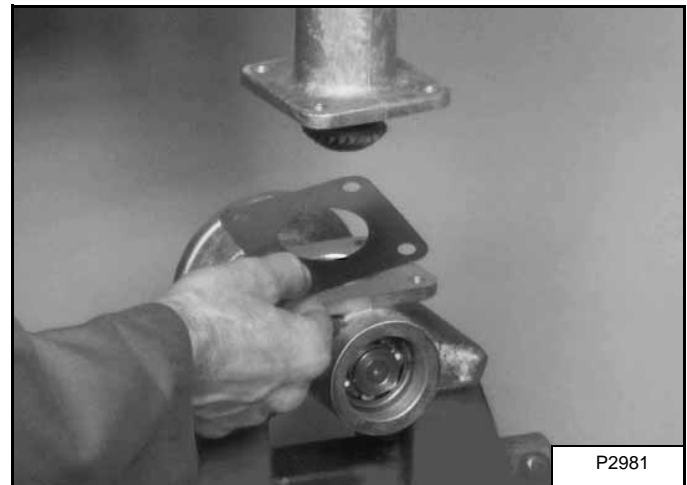

Install the same size and number of square shims (if present during disassembly) between the two housings [Figure 70-60-55].

Set the long housing on the short housing with the sealant (LOCTITE #242) which is a gasket eliminator that cures to flexible seal between the mounting surfaces.

**NOTE:** If square shims are used, put a small amount of (LOCTITE #242) on both sides of all shims.

## ENGINE COMPONENTS AND TESTING (CONT'D)

### Fuel Injection Pump Removal And Installation

# IMPORTANT

Do not bend the high pressure fuel injection tubes when removing or installing them.

I-2029-0289

Figure 70-70-15

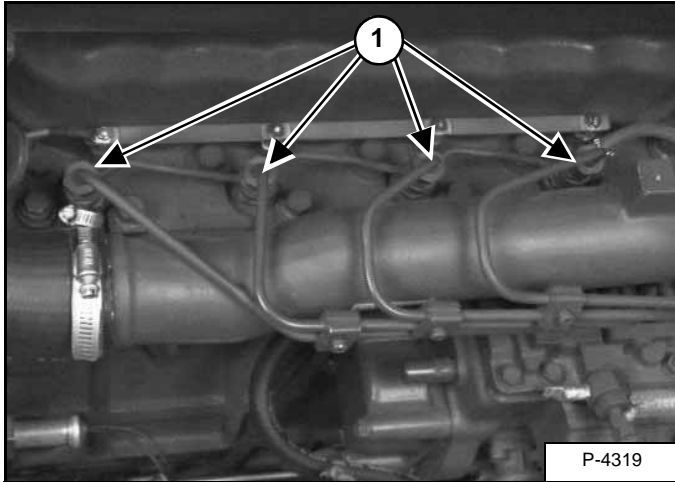

Clean the area around the injection pump thoroughly.

Disconnect the high pressure fuel lines (Item 1) [Figure 70-70-15] from the fuel injectors.

Figure 70-70-16

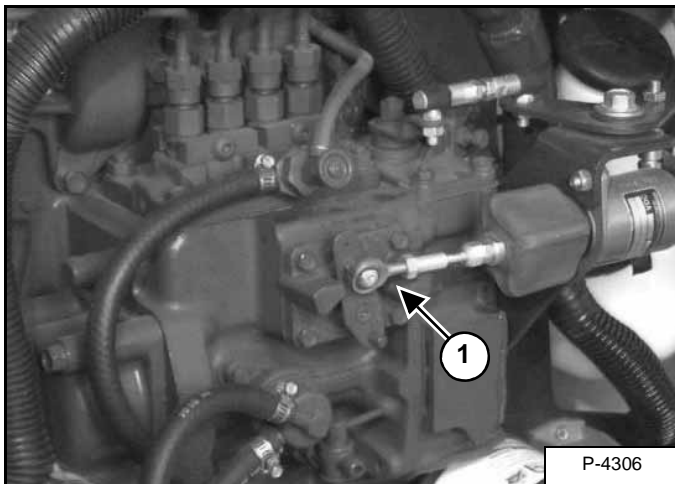

Disconnect the fuel shut-off linkage (Item 1) [Figure 70-70-16].

Figure 70-70-17

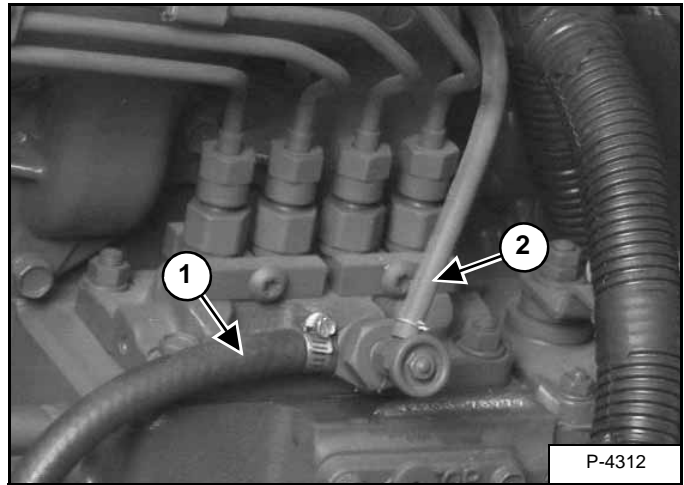

Disconnect the fuel inlet hose (Item 1) and the fuel return hose (Item 2) [Figure 70-70-17] from the injection pump vent.

Figure 70-70-18

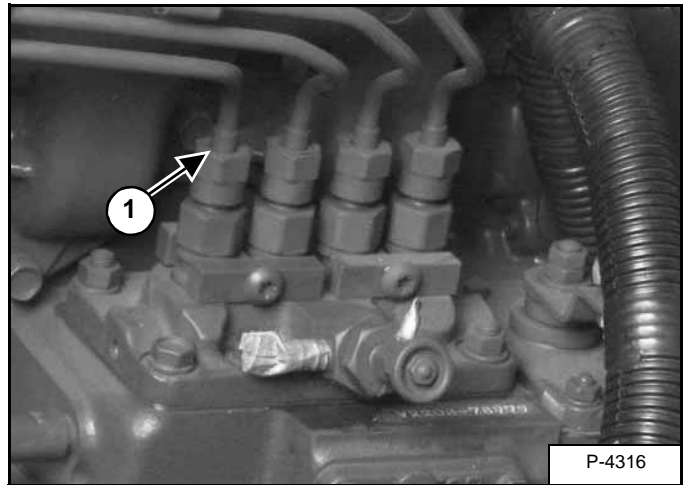

Cap the inlets on the injection pump vent where the hoses were removed [Figure 70-70-18].

Remove the high pressure fuel lines (Item 1) [Figure 70-70-18] from the injection pump.

## ENGINE (CONT'D)

### Removal And Installation (Cont'd)

Figure 70-80-3

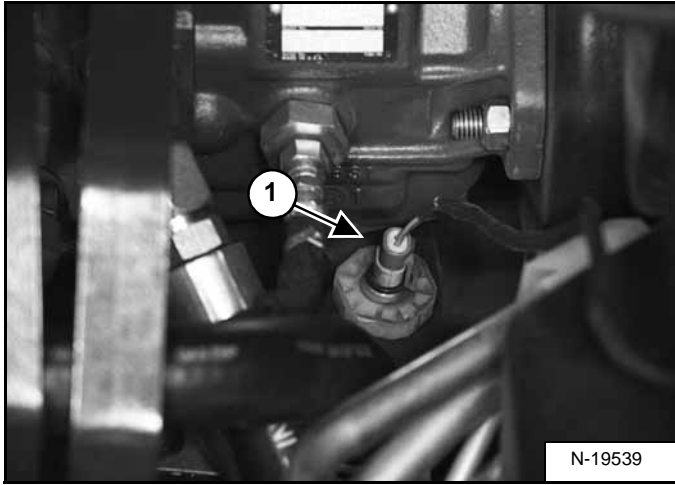

Disconnect the wire harness connector (Item 1) [Figure 70-80-3] from the fuel level sender on the fuel tank.

Figure 70-80-4

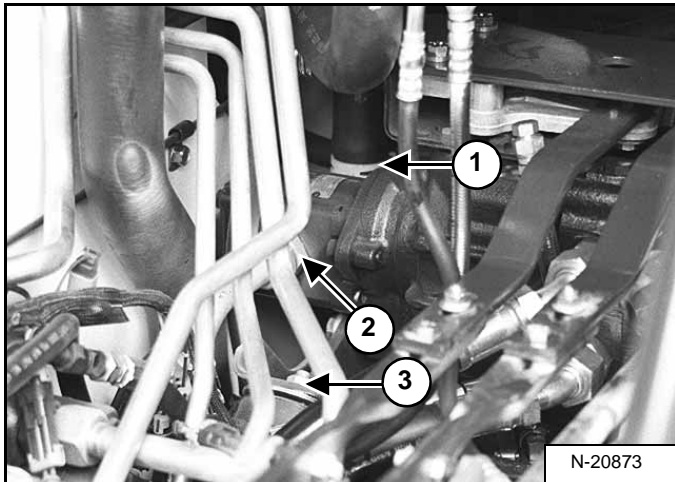

Disconnect the INLET hose (Item 1) [Figure 70-80-4] from the fitting on the hydraulic pump.

Disconnect the outlet tubeline (Item 2) [Figure 70-80-4] to the main control valve, from the fitting on the hydraulic pump.

Remove the mounting bolt (Item 3) [Figure 70-80-4] and nut from the right front engine mount.

Figure 70-80-5

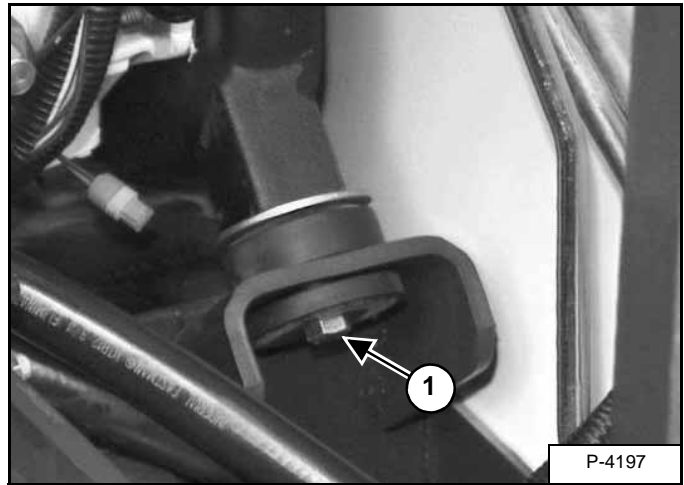

Remove the mounting bolt (Item 1) [Figure 70-80-5] and nut from the left front engine mount.

**Installation:** Tighten the mounting bolts to 70 ft.-lbs. (95 Nm) torque.

Figure 70-80-6

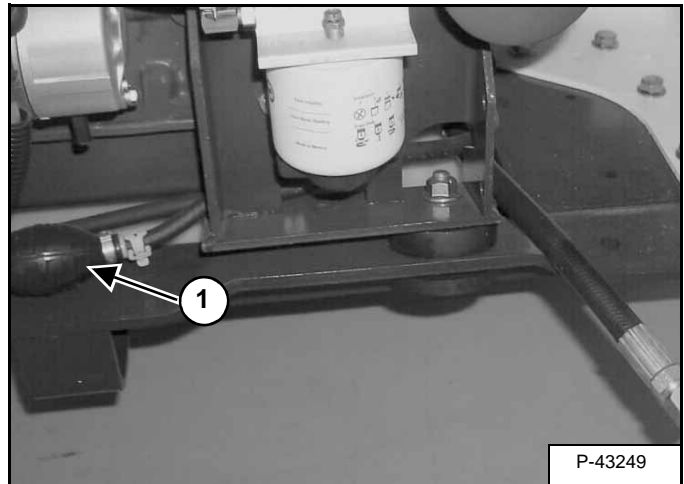

Disconnect the hand pump (Item 1) [Figure 70-80-6] from the fuel line connected to the fuel tank. Cap the fuel lines.



**Bobcat®**

## RECONDITIONING THE ENGINE (CONT'D)

### Servicing The Camshaft

Figure 70-100-35

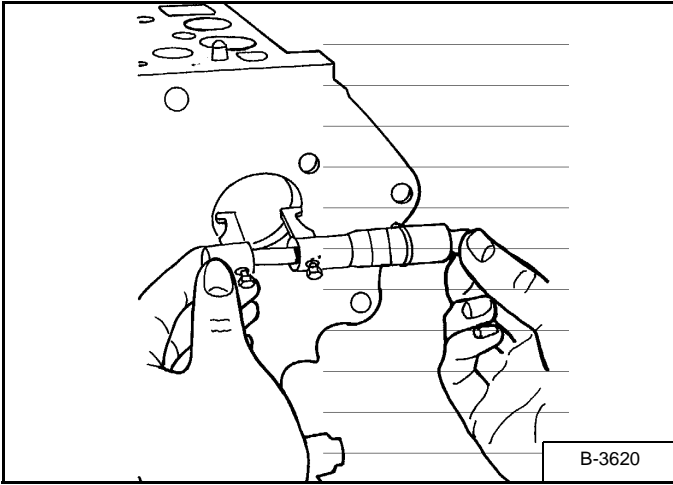

Measure the camshaft bearing in the engine block [Figure 70-100-35].

Figure 70-100-36

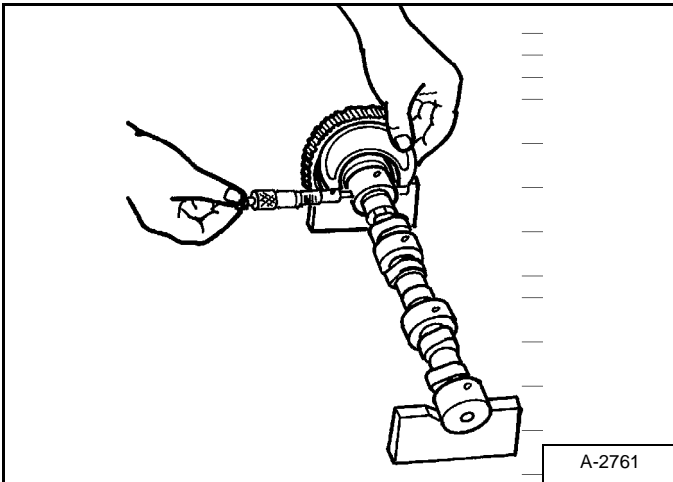

Measure the camshaft journal [Figure 70-100-36].

Calculate the oil clearance. If the clearance exceeds the allowable limit, replace the camshaft.

Bearing I.D.	1.5748-1.5758 inches (40,0-40,03) mm
Journal O.D.	1.5722-1.5728 inches (39,93-39,95) mm
Oil Clearance of Camshaft Journal	0.002-0.0036 inch (0,05-0,09) mm
AllowableLimit	0.006 inch (0,15) mm

Figure 70-100-37

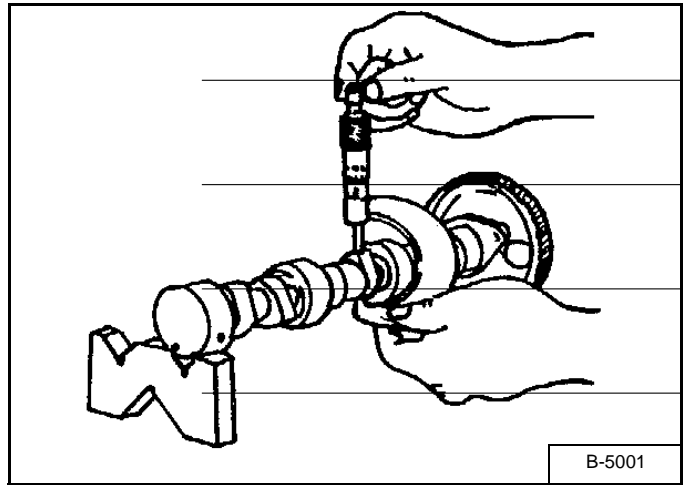

Measure the cam lobes at their highest point [Figure 70-100-37].

If the measurement is less than the allowable limit, replace the camshaft.

CamLobeHeight	1.318 inches (33,47 mm)
AllowableLimit	1.316 inches (33,42 mm)

Figure 70-100-38

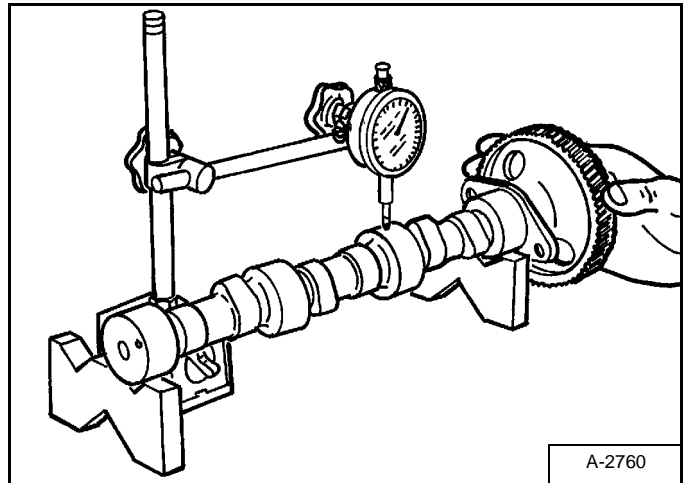

Put the camshaft in V-blocks. Install a dial indicator [Figure 70-100-38] on the camshaft bearing surface.

Turn the camshaft at a slow rate. If the misalignment exceeds the allowable limit, replace the camshaft.

Camshaft Alignment AllowableLimit	0.004 inch (0,01 mm)
--------------------------------------	----------------------

## RECONDITIONING THE ENGINE (CONT'D)

### Crankshaft And Bearings Removal And Installation

Figure 70-100-66

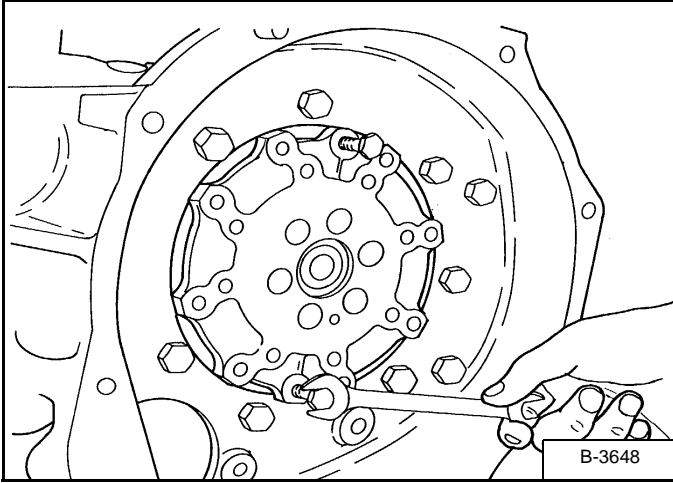

Remove the piston and connecting rod assemblies. (See Piston And Connecting Rod Removal And Installation on Page 70-100-16.)

Remove the engine flywheel. (See Flywheel Removal And Installation on Page 70-90-1.)

Remove the bolts which fasten the bearing case cover to the block.

**Installation:** Tighten the bearing case cover bolts to 13-15 ft.-lbs. (18-21 Nm) torque.

Install two bolts into the bearing case cover and pull the cover out [Figure 70-100-66].

Figure 70-100-67

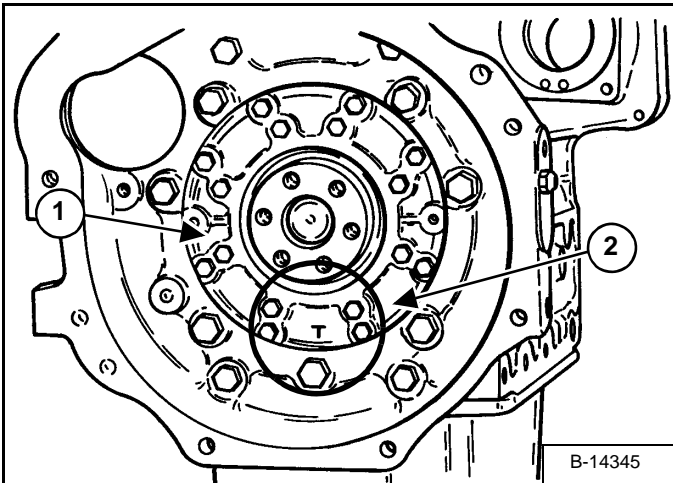

**Installation:** When installing the cover (Item 1), make sure the casting mark (Item 2) [Figure 70-100-67] is in the down position.

Figure 70-100-68

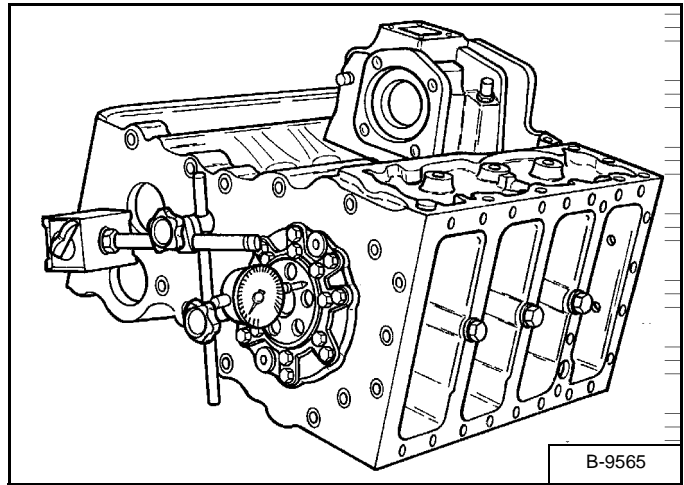

Before removing the crankshaft/main bearings, check the end play. Install a dial indicator. Measure the end play by moving the crankshaft back and forth [Figure 70-100-68].

If the measurement exceeds the allowable limit, replace the thrust washers.

End Play	0.0059-0.0122 inch (0,15-0,31 mm)
Allowable Limit	0.0197 inch (0,5 mm)

Figure 70-100-69

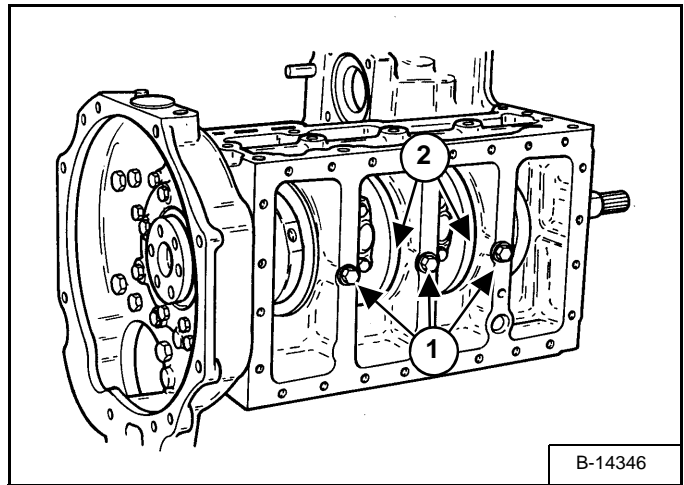

Remove the main bearing case bolt (Item 1) [Figure 70-100-69].

**Installation:** Make alignment of the bearing case hole (Item 2) [Figure 70-100-69] with the hole in the block. Put oil on the bolt threads and tighten to 51-54 ft.-lbs. (69-73 Nm) torque.

## COMPONENTS (CONT'D)

### Identification (Cont'd)

Figure 80-10-5

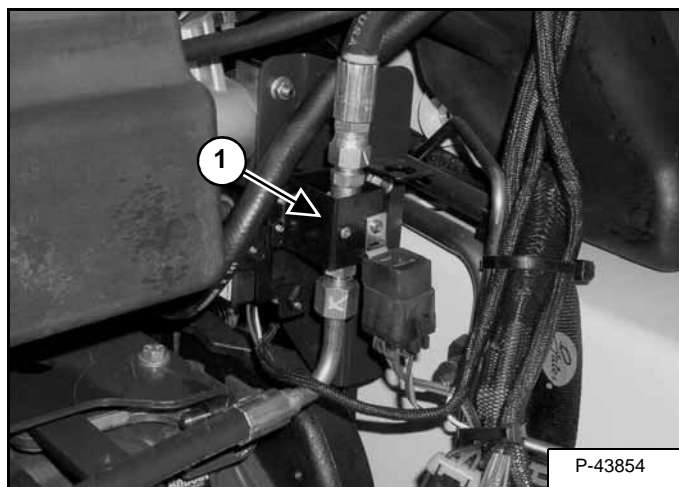

*Heater Valve:* The heater valve (Item 1) [Figure 80-10-5] is used to control the amount of engine coolant that flows to the heater coil.

## BASIC TROUBLESHOOTING (CONT'D)

### Checking The Electrical System (Cont'd)

Figure 80-30-19

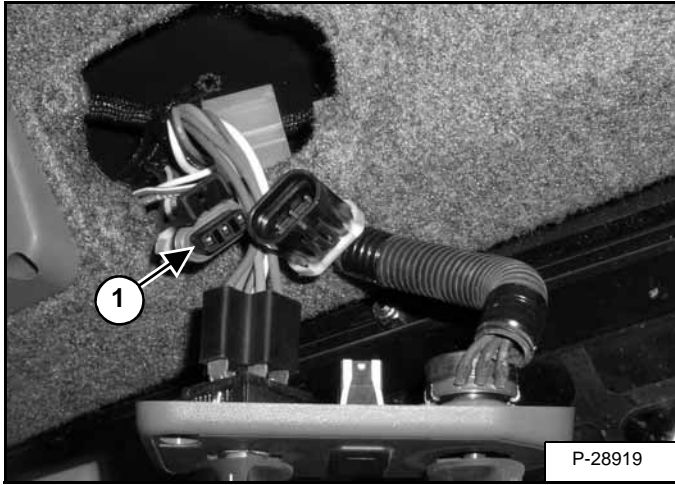

Check the loader harness (Item 1) [Figure 80-30-19] for voltage. The voltage should be 12 volts.

If there is no voltage at the wiring harness, check the harness for broken wires or blown fuse.

Figure 80-30-20

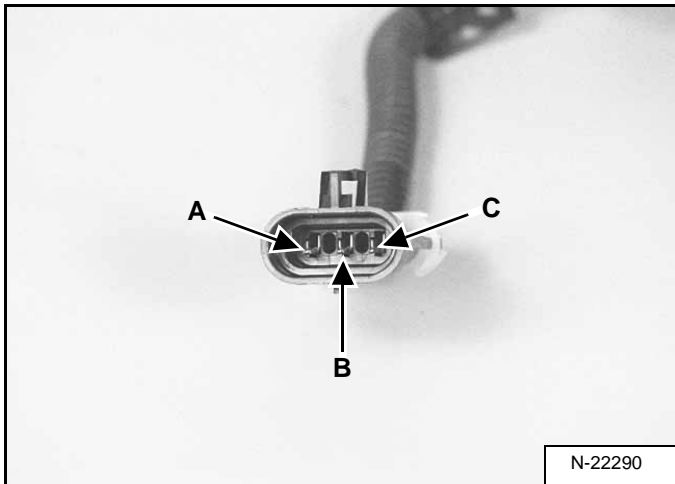

If there is voltage at the wiring harness, check the potentiometer [Figure 80-30-20] for resistance.

The resistance should be 10 K Ohm's between wire terminal **A** and wire terminal **C** frame [Figure 80-30-20].

If no resistance is found replace the potentiometer.

Figure 80-30-21

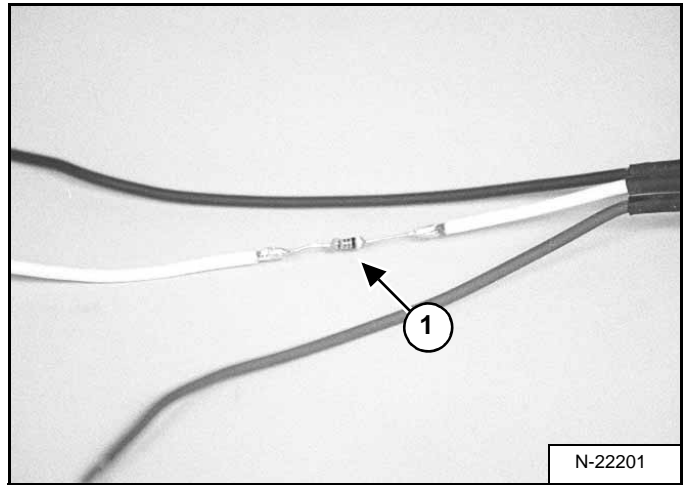

The white wire **B**, (Item 1) [Figure 80-30-21], on the potentiometer, is a resistor wire.

Figure 80-30-22

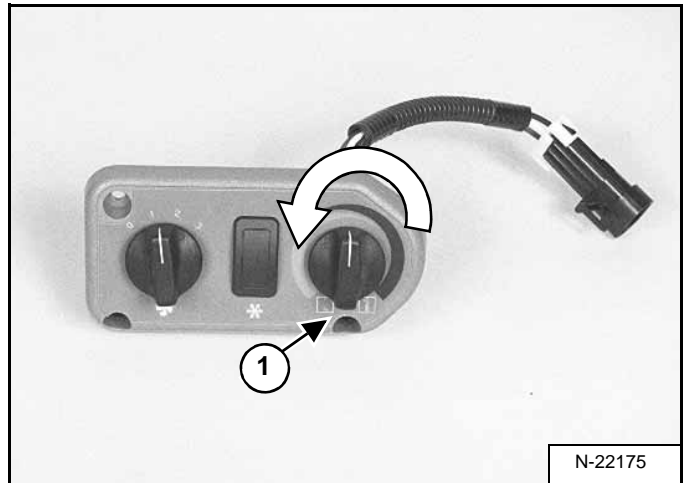

To check the resistance of the white wire, turn the potentiometer control (Item 1) [Figure 80-30-22] to the full A/C position.



**Bobcat®**

## SPECIFICATIONS (CONT'D)

TORQUE SPECIFICATIONS FOR BOLTS . . . . .	SPEC-30-1
Torque For General Metric Bolts . . . . .	SPEC-30-2
Torque For General SAE Bolts. . . . .	SPEC-30-1
Torque For Kubota Metric Bolts . . . . .	SPEC-30-2

## ENGINE SPECIFICATIONS (CONT'D)

*All dimensions are given in inches. Respective metric dimensions are given in millimeters enclosed by parentheses.*

### Crankshaft

Crankshaft Alignment Limit Permitted	0.00079 (0,02)
Oil Clearance Between Journal & Bearing #1	0.0016-0.0046 (0,04-0,118)
Limit Permitted	0.0079 (0,2)
Journal O.D. #1	2.0441-2.0449 (51,921-51,94)
Bearing I.D. #1	2.0465-2.0488 (51,98-52,04)
Oil Clearance Between Journal & Bearing #2	0.0016-0.0041 (0,04-0,104)
Limit Permitted	0.0079 (0,2)
Journal O.D. #2	2.0441-2.0449 (51,92-51,94)
Bearing I.D. #2	2.0465-2.0482 (51,98-52,02)
Oil Clearance Between Crank Pin & Bearing	0.0009-0.0034 (0,025-0,087)
Limit Permitted	0.008 (0,2)
Crank Pin O.D.	1.8488-1.8494 (46,96-46,97)
Crank Pin Bearing I.D.	1.8504-1.8522 (47,0-47,046)
Crankshaft Side Clearance	0.0059-0.0122 (0,15-0,31)
Limit Permitted	0.0197 (0,5)

### Timing Gear

Timing Gear Backlash:	
Crank Gear-Idle Gear	0.0016-0.0044 (0,042-0,112)
Idle Gear-Cam Gear	0.0016-0.0045 (0,042-0,115)
Idle Gear-Injection Pump Gear	0.0016-0.0045 (0,042-0,115)
Crank Gear-Oil Pump Gear	0.0016-0.0043 (0,042-0,109)
Limit Permitted	0.006 (0,15)
Clearance Between Idle Gear Shaft & Idle Gear Bushing	0.001-0.0026 (0,025-0,066)
Limit Permitted	0.004 (0,10)
Idle Gear Side Clearance Idle Gear	0.008-0.020 (0,2-0,51)

### Thermostat

Valve Opening Temperature	157-163°F (70-73°C)
Valve Fully Open	185°F (85°C)



**Bobcat**®

CLICK HERE TO **DOWNLOAD** THE COMPLETE MANUAL

- Thank you very much for reading the preview of the manual.
- You can download the complete manual from: [www.heydownloads.com](http://www.heydownloads.com) by clicking the link below



- Please note: If there is no response to CLICKING the link, please download this PDF first and then click on it.

CLICK HERE TO **DOWNLOAD** THE COMPLETE MANUAL