

# 2017

## SERVICE MANUAL



WILDCAT<sup>®</sup> TRAIL

CLICK HERE TO **DOWNLOAD** THE COMPLETE MANUAL

- Thank you very much for reading the preview of the manual.
- You can download the complete manual from: [www.heydownloads.com](http://www.heydownloads.com) by clicking the link below



- Please note: If there is no response to CLICKING the link, please download this PDF first and then click on it.

CLICK HERE TO **DOWNLOAD** THE COMPLETE MANUAL



WT021

1. Remove the spark plug wires from the spark plugs.
2. Using compressed air, blow any debris from around the spark plugs.

**⚠ WARNING**

Always wear safety glasses when using compressed air.

3. Remove the spark plugs; then attach the spark plug wires to the plugs and ground the plugs on the cylinder heads well away from the spark plug holes.
4. Attach the Compression Tester Kit.
5. While holding the throttle in the full-open position, crank the engine over with the electric starter until the gauge stops climbing (five to 10 compression strokes). Compression should be as shown in the chart.

PSI (WOT)	
Cylinder #1/Cylinder #2	185

6. If compression is abnormally low, verify the following:
  - A. Starter cranks engine over (normal speed).
  - B. Gauge is functioning properly.
  - C. Throttle in the full-open position.
  - D. Valve/tappet clearance correct.
  - E. Engine warmed up.
7. If compression is still low, service the top end (see Engine – Servicing Top-Side Components).

## Spark Plugs

A light brown insulator indicates the plug and fuel/air ratio are correct. A white or dark insulator indicates that the engine may need to be serviced. To maintain a hot, strong spark, keep the plug free of carbon. Adjust the gap to 0.6-0.8 mm (0.023-0.031 in.).

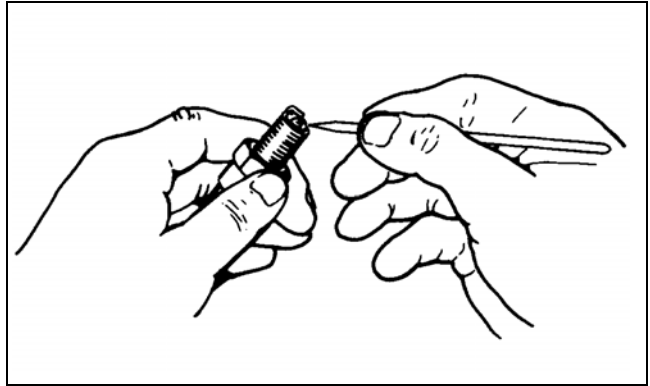

ATV-0051

**CAUTION**

Before removing a spark plug, be sure to clean the area around the spark plug. Dirt could enter engine when removing or installing the spark plug.

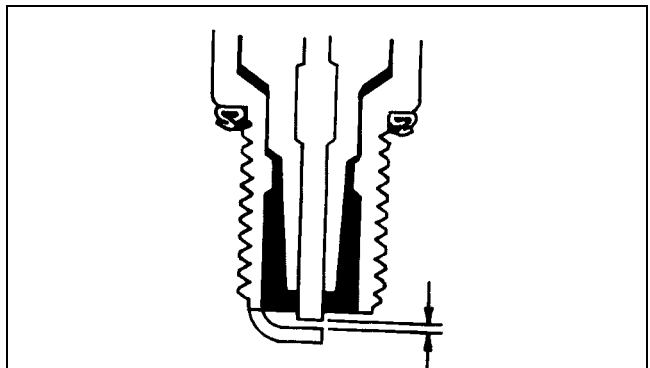

ATV-0052

A new spark plug should be tightened 1/2 turn once the washer contacts the cylinder head. A used spark plug should be tightened 1/8-1/4 turn once the washer contacts the cylinder head.

## Muffler/Spark Arrester

Clean the spark arrester using the following procedure.

**⚠ WARNING**

Wait until the muffler cools to avoid burns.

1. Remove the spark arrester screen; then using a suitable brush, clean the carbon deposits from the screen taking care not to damage the screen.



WT005A

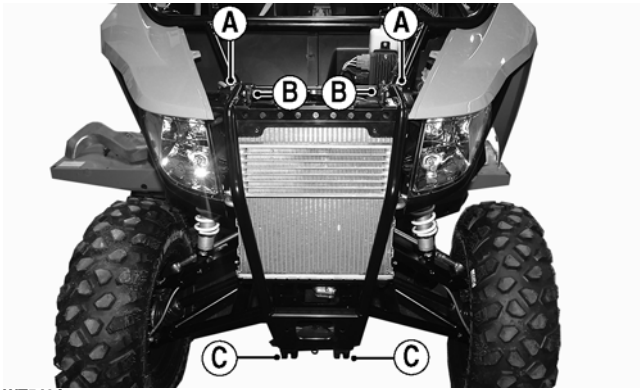

WT548A

2. Install the lower bumper cap screws (C); then tighten the upper and lower bumper cap screws to 20 ft-lb.
3. Install the cap screws and nuts securing the radiator to the frame (B). Tighten to 8 ft-lb.
4. Install the cap screws securing the front fenders to the frame; then tighten securely.
5. Connect the headlights.
6. Using the existing cap screws, secure the grille and tighten securely.
7. Install the hood and secure with the quarter-turn fasteners

---

## Hood and Grille

---

### REMOVING/INSTALLING HOOD

1. Turn the two quarter-turn fasteners counterclockwise and remove hood.



WT226A

2. Insert the hood tabs into the grille and lay the hood down flat. Turn both of the fasteners clockwise securing the hood.



WT251

### REMOVING GRILLE

Remove the fasteners securing the grille; then remove the grille.



WT256A

### CLEANING AND INSPECTING GRILLE

Clean any dirt or debris from the grille webbing. This helps air flow to the radiator and oil cooler.

### INSTALLING GRILLE

Place the grille into position and secure it using the existing cap screws. Tighten all hardware to 60 in.-lb.

---

## Body Panels

---

### REMOVING REAR BODY PANELS

1. Remove the seats.
2. Remove the push pins and cap screws securing the rear fenders.

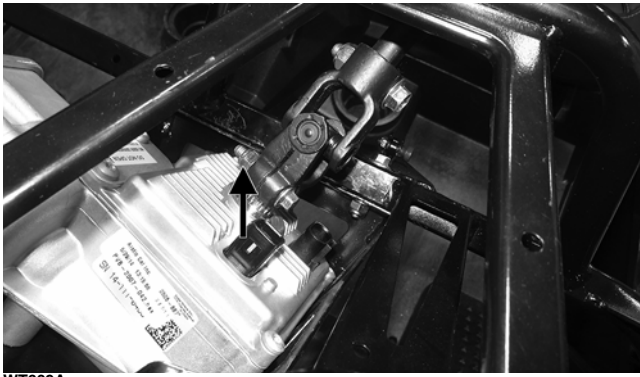

WT609A

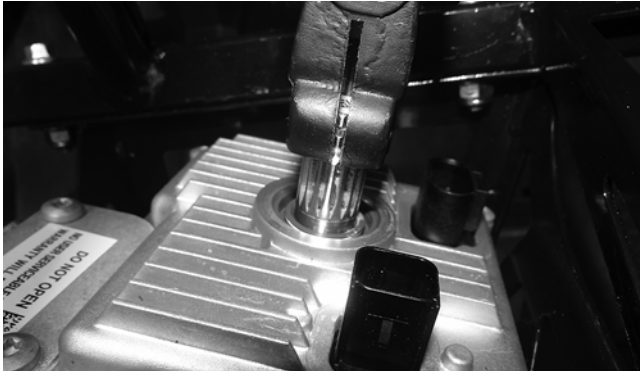

WT605

3. Secure the EPS assembly with cap screws and new lock nuts. Tighten to 20 ft-lb.

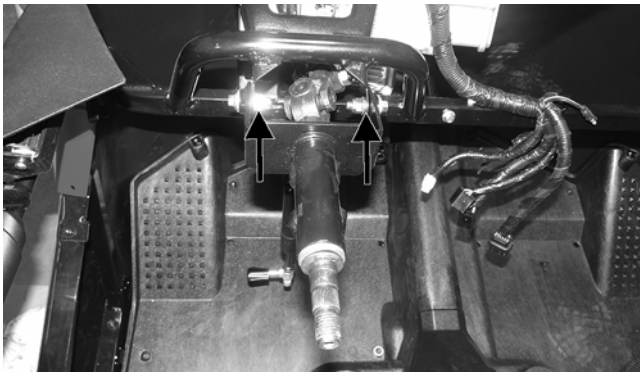

WT607A

4. Install the cap screw and new lock nut securing the lower steering shaft to the EPS assembly.

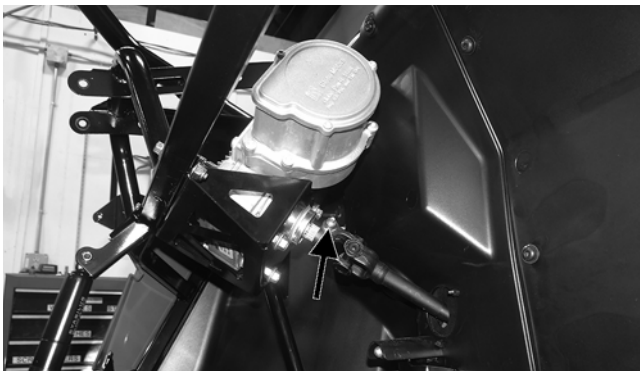

WT604B

■NOTE: Loosening but not removing the cap screw connecting the steering shaft to the rack and pinion will aid in installing the lower cap screw connecting the lower steering shaft to the EPS assembly. If this step was done, the lower lock nut must be replaced and tightened to 25 ft-lb.

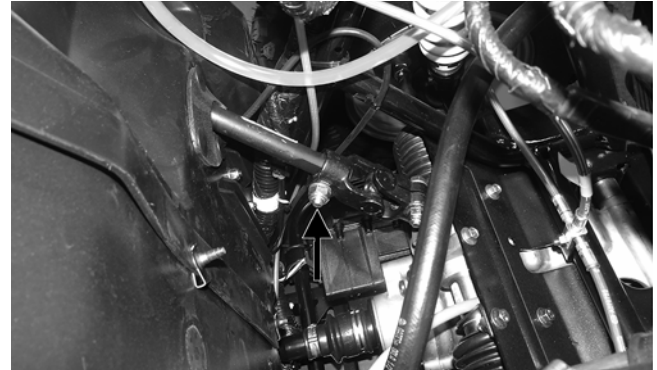

WT610A

5. Tighten the cap screws securing the EPS assembly to the frame to 35 ft-lb.
6. Install the dash, hood, and steering wheel.

---

## Steering Shaft

---

### REMOVING

1. Remove the steering wheel and hood; then remove the dash.
2. Remove and discard the cap screws and lock nuts securing the steering tilt assembly to the frame.



WT346

3. Remove the push pins securing the rubber boot to the splash panel.

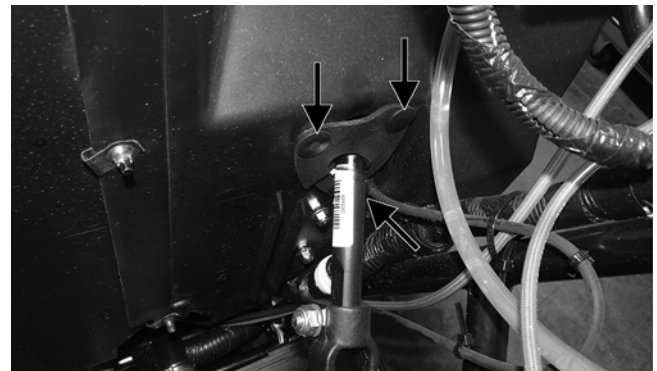

WT343A

# Troubleshooting

Problem: Handling too heavy or stiff	
Condition	Remedy
<ol style="list-style-type: none"> <li>1. <b>Front wheel alignment</b> incorrect</li> <li>2. <b>Lubrication</b> inadequate</li> <li>3. <b>Tire inflation</b> pressure incorrect</li> <li>4. <b>Tie rod ends</b> seizing</li> <li>5. <b>Linkage connections</b> seizing</li> <li>6. <b>EPS</b> malfunction</li> </ol>	<ol style="list-style-type: none"> <li>1. Adjust alignment</li> <li>2. Lubricate appropriate components</li> <li>3. Adjust pressure</li> <li>4. Replace tie rod ends</li> <li>5. Repair - replace connections</li> <li>6. Troubleshoot - replace EPS</li> </ol>
Problem: Steering oscillation	
Condition	Remedy
<ol style="list-style-type: none"> <li>1. <b>Tires</b> inflated unequally</li> <li>2. <b>Wheel(s)</b> wobbly</li> <li>3. <b>Wheel hub cap screw(s)</b> loose - missing</li> <li>4. <b>Wheel hub bearing</b> worn - damaged</li> <li>5. <b>Tie rod ends</b> worn - loose</li> <li>6. <b>Tires</b> defective - incorrect</li> <li>7. <b>A-arm bushings</b> damaged</li> <li>8. <b>Bolts - nuts (frame)</b> loose</li> </ol>	<ol style="list-style-type: none"> <li>1. Adjust pressure</li> <li>2. Replace wheel(s)</li> <li>3. Tighten - replace cap screws</li> <li>4. Replace bearing</li> <li>5. Replace - tighten tie rod ends</li> <li>6. Replace tires</li> <li>7. Replace bushings</li> <li>8. Tighten bolts - nuts</li> </ol>
Problem: Steering pulling to one side	
Condition	Remedy
<ol style="list-style-type: none"> <li>1. <b>Tires</b> inflated unequally</li> <li>2. <b>Front wheel alignment</b> incorrect</li> <li>3. <b>Wheel hub bearings</b> worn - broken</li> <li>4. <b>Frame</b> distorted</li> <li>5. <b>Shock absorber</b> defective</li> </ol>	<ol style="list-style-type: none"> <li>1. Adjust pressure</li> <li>2. Adjust alignment</li> <li>3. Replace bearings</li> <li>4. Repair - replace frame</li> <li>5. Replace shock absorber</li> </ol>
Problem: Steering impaired	
Condition	Remedy
<ol style="list-style-type: none"> <li>1. <b>Tire pressure</b> too high</li> <li>2. <b>Steering linkage connections</b> worn</li> <li>3. <b>Cap screws (suspension system)</b> loose</li> </ol>	<ol style="list-style-type: none"> <li>1. Adjust pressure</li> <li>2. Replace connections</li> <li>3. Tighten cap screws</li> </ol>
Problem: Tire wear rapid or uneven	
Condition	Remedy
<ol style="list-style-type: none"> <li>1. <b>Wheel hub bearings</b> worn - loose</li> <li>2. <b>Front wheel alignment</b> incorrect</li> </ol>	<ol style="list-style-type: none"> <li>1. Replace bearings</li> <li>2. Adjust alignment</li> </ol>
Problem: Steering noise	
Condition	Remedy
<ol style="list-style-type: none"> <li>1. <b>Caps screws - nuts</b> loose</li> <li>2. <b>Wheel hub bearings</b> broken - damaged</li> <li>3. <b>Lubrication</b> inadequate</li> </ol>	<ol style="list-style-type: none"> <li>1. Tighten cap screws - nuts</li> <li>2. Replace bearings</li> <li>3. Lubricate appropriate components</li> </ol>
Problem: Rear wheel oscillation	
Condition	Remedy
<ol style="list-style-type: none"> <li>1. <b>Rear wheel hub bearings</b> worn - loose</li> <li>2. <b>Tires</b> defective - incorrect</li> <li>3. <b>Wheel rim</b> distorted</li> <li>4. <b>Wheel hub cap screws</b> loose</li> <li>5. <b>Rear suspension</b> lateral link bushing worn</li> <li>6. <b>Trailing arm bushings</b> worn</li> <li>7. <b>Rear suspension</b> lateral link loose</li> </ol>	<ol style="list-style-type: none"> <li>1. Replace bearings</li> <li>2. Replace tires</li> <li>3. Replace wheel</li> <li>4. Tighten cap screws</li> <li>5. Replace bushing</li> <li>6. Replace bushings or link</li> <li>7. Tighten nut or replace</li> </ol>



ROV1-002

6. Remove the chain guide.



KC548A



KC520

■NOTE: Take care not to drop the fasteners down into engine.

7. Remove the cap screws securing the intake and exhaust camshaft retainers.

■NOTE: Tapping on the end of the camshaft holder with a rubber mallet opposite the sprocket will aid in removing the camshaft holder.



KC549A

8. Lift on the chain and remove both camshafts and sprockets; then using a suitable holder, hook the chain and let it hang over the side of the head.

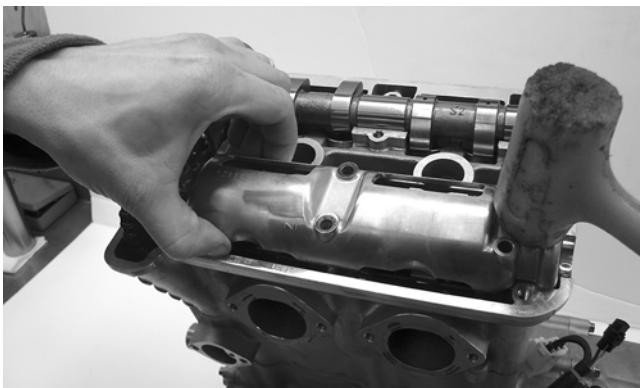

ROV1-010

■NOTE: The camshaft holder and cylinder head have matching code numbers and must remain a set.



ROV1-019

9. On the left side of the head, remove the three cap screws.

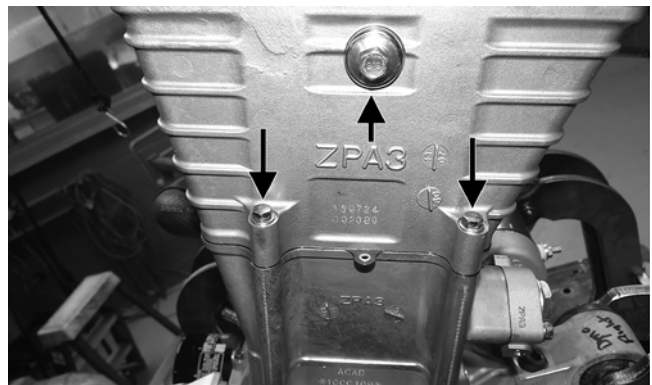

ROV1-021A

10. Loosen the six head bolts securing the cylinder head to the cylinder.

11. Install the cap screws (threads coated with oil) with the two longer bolts going in the dowel pin locations.

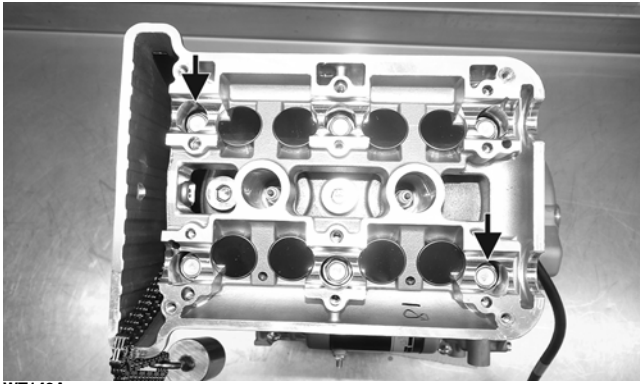

WT142A

12. In the order shown, tighten the head bolts to 22 ft-lb, then to 29 ft-lb, and finally to 36 ft-lb.

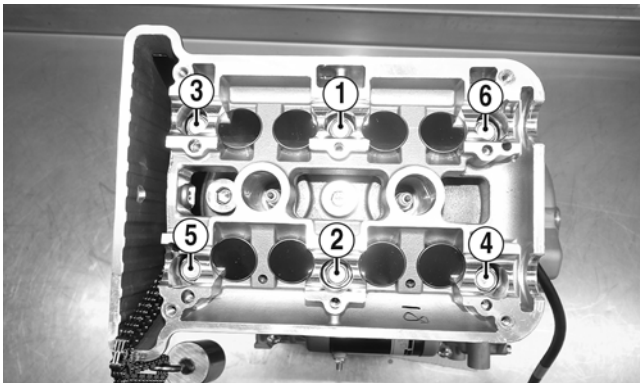

WT142B

■NOTE: Care must be taken not to damage the cam shaft journals while tightening the head bolts.

13. With a light film of engine-assembly grease applied to the tappets, install the correct shim (B) and tappet (A) to each valve of the cylinder head as noted during disassembling.

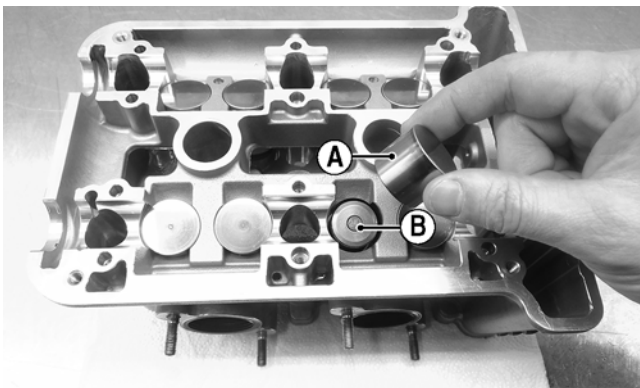

WT471A

14. Install the two left-side fasteners and tighten to 7 ft-lb.

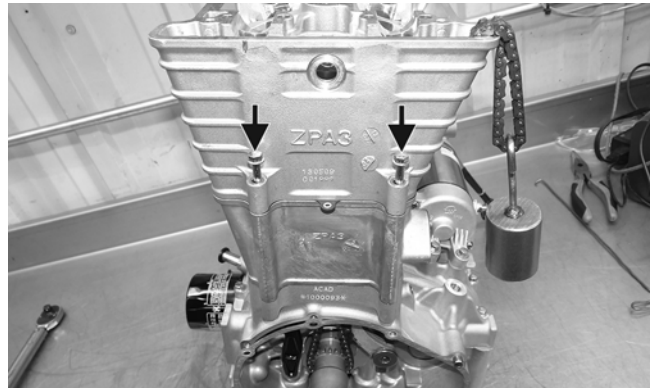

WT143A

15. Making sure the chain stays on the crankshaft sprocket, rotate the engine to TDC.



WT145

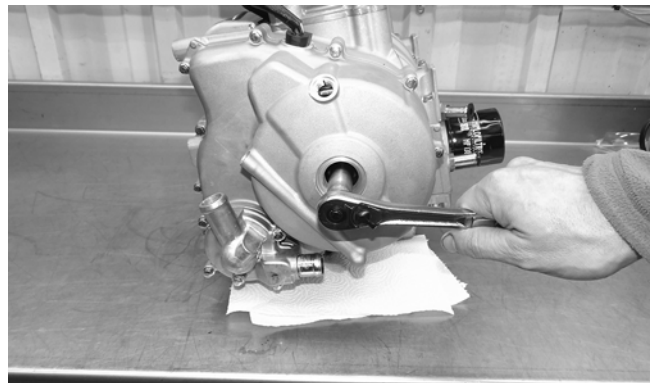

WT144

16. Install the exhaust cam shaft; then install the chain around the sprocket so the exhaust timing mark is parallel with the head surface.



WT147

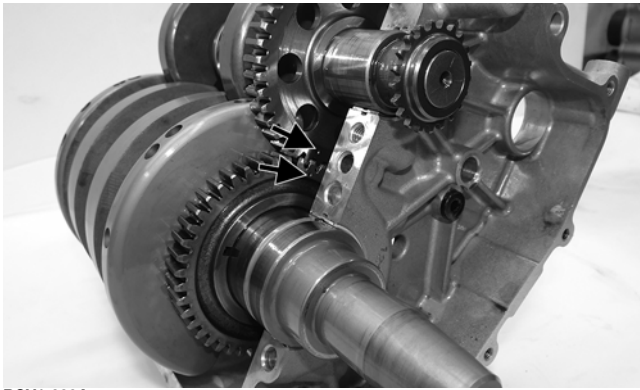

ROV1-089A

5. Wipe off the sides of the case half; then apply a bead of high-temp silicone to the sides of the case half.

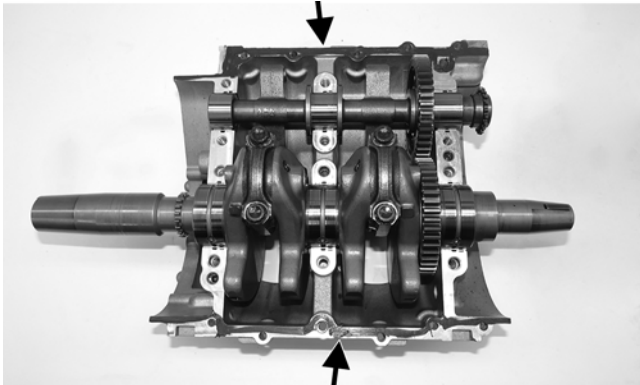

ROV1-090A

6. Install the bottom end of the crankcase and install the existing eleven cap screws and washers. Tighten to 21 ft-lb.

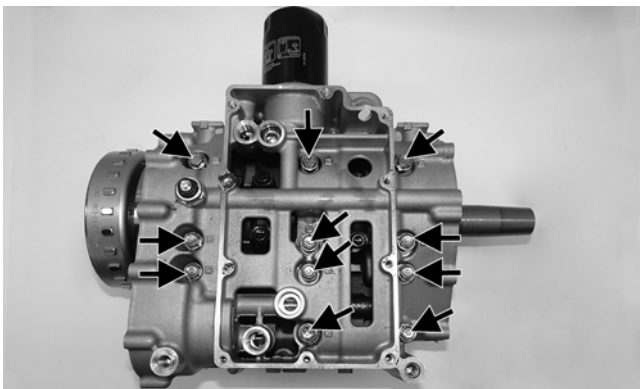

ROV1-078A

■NOTE: The longer fasteners go in the holes numbered one through six.

7. Rotate the engine to right-side up and install the remaining crankcase cap screws and washers. Tighten the cap screws (A) to 7 ft-lb and the cap screw (B) to 21 ft-lb.

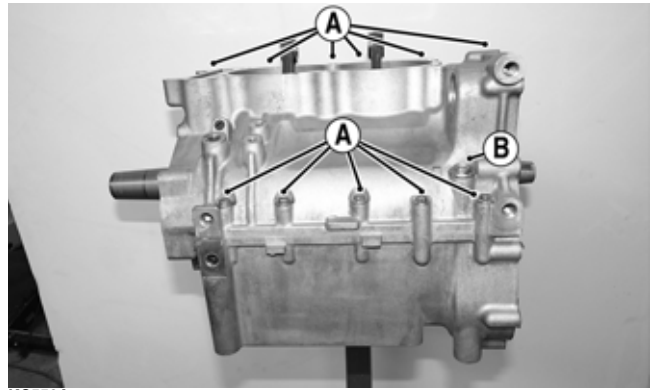

KC550A

■NOTE: The longer bolt is installed just to the right of the oil filter.

8. Rotate the engine again and using a twelve-point socket, tighten the connecting rods to 22 ft-lb, then to 36 ft-lb, and finally to 45 ft-lb.

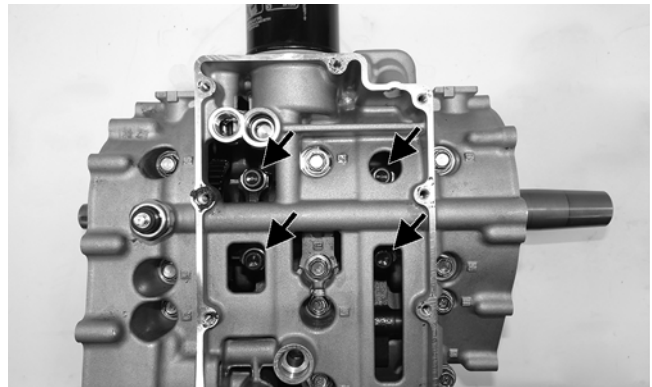

ROV1-091A

■NOTE: Rotating the crankshaft will aid in lining up the fasteners.

9. Install the oil crossover tube. Tighten to 13.5 ft-lb.

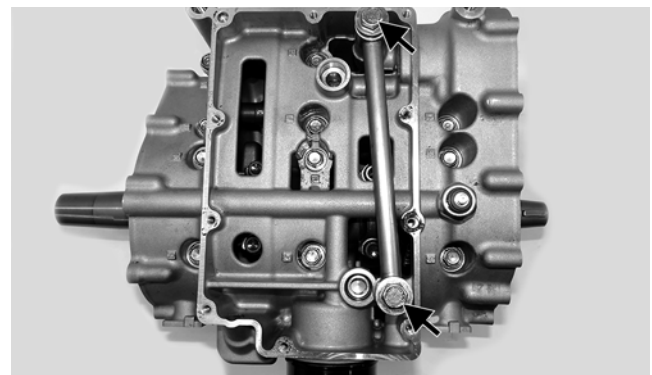

ROV1-092A

■NOTE: Verify the correct positioning of the washers.

10. Place the rubber O-ring into the oil pressure relief valve bore; then push the oil pressure relief valve until the O-ring on the valve is past the chamfer.

CLICK HERE TO **DOWNLOAD** THE COMPLETE MANUAL

- Thank you very much for reading the preview of the manual.
- You can download the complete manual from: [www.heydownloads.com](http://www.heydownloads.com) by clicking the link below



- Please note: If there is no response to CLICKING the link, please download this PDF first and then click on it.

CLICK HERE TO **DOWNLOAD** THE COMPLETE MANUAL

21. Install the clutch cover assembly with the air outlet duct connected to the inner clutch cover; then using the original cap screws, install the inner clutch cover to the engine. Tighten to 8 ft-lb.
22. Install the drive clutch; then install the driven clutch moveable sheave. Tighten the cap screws to 60 ft-lb.
23. Using the existing flat washer, install the belt and the stationary sheave of the driven clutch. Tighten the cap screw to 35 ft-lb.

**👉 AT THIS POINT**

**Check clutch alignment (see Servicing Left-Side Components in this section).**

24. Install the outer clutch cover to the inner clutch cover. Tighten to 5 ft-lb.
25. Install the left-rear wheel; then using a crisscross pattern, tighten the wheel nuts in 20 ft-lb increments to a final torque of 40 ft-lb (steel wheel), 60 ft-lb (aluminum wheel w/black nuts), or 80 ft-lb (aluminum wheel w/chrome nuts).
26. Install the air intake tube and secure it to the frame and air filter housing with the worm clamp.



WT311A



WT408A

27. Install the rear splash panels and secure them with the cap screws. Install the push pins securing the wiring harness to the left-side splash panel.

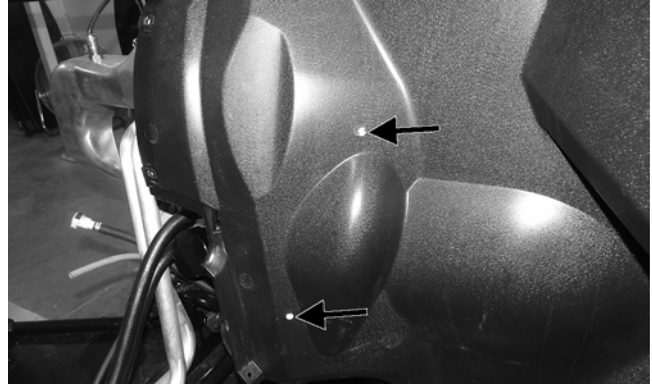

WT364A

28. Install the rear fenders (see Steering/Body/Controls).
29. Install the vent hose, gasoline hose (with conduit), and fuel pump connector.

**■NOTE:** Be sure to route the gasoline hose and vent hose through the hole on the right side splash panel.



WT614

30. Install the cargo box. Tighten to 5 ft-lb.



WT546A

2. Install the thermostat cover; then making sure the thermostat is properly seated, tighten the cap screws to 5 ft-lb.
3. Install the hose on the bottom of thermostat housing and secure with the hose clamp.
4. Remove the close-off clamps; then install the muffler and secure with the springs.
5. Add the recommended anti-freeze as required; then bleed the cooling system and check for leaks.

## Fan

### REMOVING

1. Remove the radiator.
2. Remove the fan assembly from the radiator.

### INSTALLING

1. Position the fan assembly on the radiator; then secure with existing hardware.

■NOTE: The fan wiring must be directed downward.

2. Install the radiator.

## Water Pump

■NOTE: The water pump is a non-serviceable component. It must be replaced as an assembly.

### REMOVING

■NOTE: If the engine is still in the vehicle, drain the oil and remove the muffler, exhaust pipe, and right-side inner splash panel.

1. Using appropriate clamps, close off the coolant hose before and after the water pump.

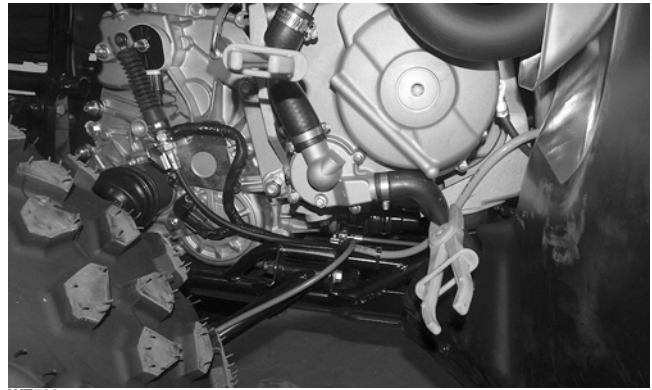

WT533

2. Drain the coolant from the pump and remove the hoses from the water pump.

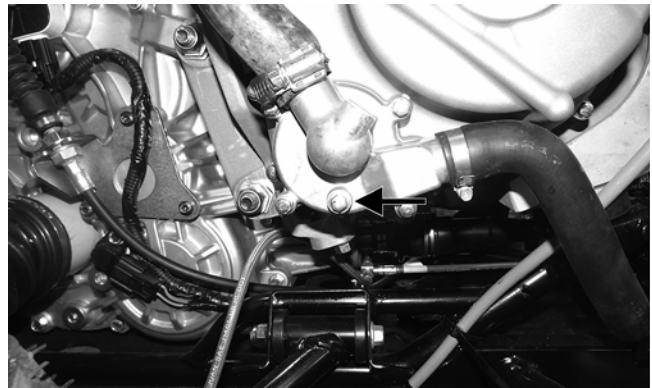

WT399A

3. Remove the cap screws securing the magneto cover to the engine.
4. Remove the cap screws securing the impeller cover to the magneto cover. Account for an O-ring and two dowel pins.

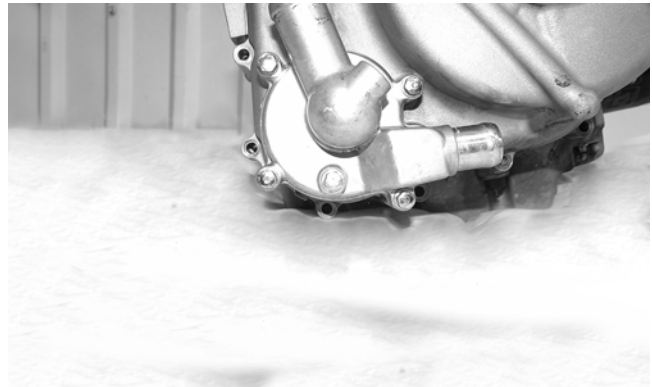

WT578

5. Remove the E-clip and washer from the impeller shaft and remove the impeller from the case half.

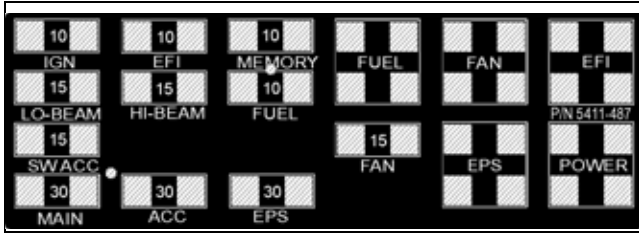

5411-487

This vehicle uses automotive-style (see-through) fuses. The fuses can be visually inspected; replace fuse if link is open.

### CAUTION

Always replace a blown fuse with a fuse of the same type and rating.

■NOTE: Make sure the fuses are returned to their proper position according to amperage. Refer to the amperage listed under each fuse on the power distribution module.

## EFI Sensors/Components

### FUEL INJECTOR



Component data can be tested using the CATT II. Utilize the Test screen.

#### Voltage

Remove the connector from the fuel injector. Place the red meter lead to the orange wire and black meter lead to ground. With the ignition switch in the on position the meter must read battery voltage.

#### Resistance

With the connector still removed from the injector, place the red meter lead to either terminal; then connect the black tester lead to the other terminal. Reading is typically 12 ohms.

■NOTE: If voltage is not present, troubleshoot the battery, connector pins, wiring harness, fuses, or relay. If resistance is not present or largely out of specification, replace the injector.

### CRANKSHAFT POSITION (CKP) SENSOR

■NOTE: The cargo box must be removed for this procedure.

The three-pin CKP connector is located in front of the air filter.



WT562

1. Set the meter selector to the OHMS position.
2. Connect the red tester lead to the brown wire; then connect the black tester lead to the white wire. The meter reading must be 100-150 ohms.
3. Set the meter selector to the AC Voltage position.

■NOTE: The battery must be at full charge for these tests.

4. Using MaxiClips, connect the red tester lead to the brown/green wire; then connect the black tester lead to the green/white wire.
5. Crank the engine over using the electric starter.
6. The meter should read approximately 1.0 volt.

### OXYGEN (O2) SENSOR



Component data can be retrieved using the CATT II. Utilize the Sensor Data screen.

The oxygen (O2) sensor is located in the exhaust pipe.

■NOTE: The ambient temperature of the engine and in the intake and exhaust system must be at room temperature (approximately 68° F) when performing this test or an incorrect reading will occur.

1. Remove the cargo box.
2. Disconnect the sensor.



WT405C

■NOTE: For this test, the meter must be in OHMS position.

## Code List

■NOTE: Each of the following numerical codes will have a one-letter prefix of C, P, or U. A “C” prefix denotes a chassis malfunction, a “P” prefix denotes a power train malfunction, and a “U” prefix denotes a loss of communication with the gauge.

■NOTE: Normal malfunction codes are cleared from the LCD when the component is replaced or the malfunction is corrected; however, intermittent codes must be cleared as noted in the code chart.

Code	Fault Description	Possible Cause	Fault Recovery
C0063	Tilt Sensor Circuit High	Sensor or interconnect harness shorted to battery power	Correct condition*
C0064	Tilt Sensor Circuit Low/SG/Open	Sensor or interconnect harness open or shorted to chassis ground	Correct condition*
C1263	Backup/Reverse-Light Circuit Open	Bulb has failed or is disconnected or interconnect harness is open	Correct condition*
C1264	Backup/Reverse-Light Circuit High	Bulb has failed or is disconnected or interconnect harness shorted to battery power	Correct condition*
C1265	Backup/Reverse-Light Circuit Low/SG	Bulb has failed or is disconnected or interconnect harness shorted to chassis ground	Correct condition*
C1400	Fuel Level Sensor Circuit Open	Sensor or interconnect harness open	Correct condition*
P0030	O2 Heater Intermittent/Open	Heater or interconnect harness is intermittent or open	Correct condition*
P0031	O2 Heater Low/SG	Heater or interconnect harness shorted to chassis ground	Correct condition*
P0032	O2 Heater High/SP	Heater or interconnect harness shorted to battery power	Correct condition*
P0107	MAP Sensor Circuit Low/SG/Open	Sensor or interconnect harness shorted to chassis ground	Correct condition*
P0108	MAP Sensor Circuit High/SP	Sensor or interconnect harness shorted to battery power	Correct condition*
P0112	Intake Air Temp Sensor Circuit Low/SG	Sensor or interconnect harness shorted to chassis ground	Correct condition*
P0113	Intake Air Temp Sensor Circuit High/Open	Sensor or interconnect harness open or shorted to battery power	Correct condition*
P0114	Intake Air Temp Sensor Circuit Intermittent	Sensor or interconnect harness intermittent	Correct condition*
P0116	ECT Sensor Circuit Range/Performance	Sensor producing an out-of-range voltage	Correct condition*
P0117	ECT Sensor Circuit Low/SG	Sensor or interconnect harness shorted to chassis ground	Correct condition*
P0118	ECT Sensor Circuit High/Open/SP	Sensor or interconnect harness open or shorted to battery power	Correct condition*
P0119	ECT Sensor Circuit Intermittent	Sensor or interconnect harness intermittent	Correct condition*
P0121	TPS Range/Performance	Sensor producing an out-of-range voltage	Correct condition*
P0122	TPS Circuit Low/SG	Sensor or interconnect harness shorted to chassis ground	Correct condition*
P0123	TPS Circuit High	Sensor or interconnect harness open or shorted to battery power	Correct condition*
P0130	O2 Sensor Intermittent/Open	Sensor or interconnect harness intermittent or open	Correct condition*
P0131	O2 Sensor Low/SG or Air-Leak	Sensor or interconnect harness shorted to chassis ground or an air-leak exists	Correct condition*
P0132	O2 Sensor High/SP	Sensor or interconnect harness shorted to battery power	Correct condition*
P0171	O2 Feedback Below Minimum Correction	Low fuel rail pressure, dirty fuel filter, or dirty injectors	Correct condition*
P0172	O2 Feedback Exceeds Maximum Correction	Excessive fuel rail pressure, MAP or temp sensors out-of-spec	Correct condition*
P0219	Engine Over-Speed Condition	Engine speed (RPM) has exceeded the ECM over-speed setpoint/limit	Reduce engine speed
P0231	Fuel Pump Relay Circuit Low/SG/Open	Relay removed or interconnect harness shorted to chassis ground	Correct condition*
P0232	Fuel Pump Relay Circuit High	Relay or interconnect harness shorted to battery power	Correct condition*
P0233	Fuel Pump Relay Circuit	Relay circuit erratic or intermittent	Correct condition*
P0261	Cylinder #1 Fuel injector Circuit Low/SG	Injector #1 or interconnect harness shorted to chassis ground	Correct condition**
P0262	Cylinder #1 Fuel injector Circuit High	Injector #1 or interconnect harness shorted to battery power	Correct condition**
P0263	Cylinder #1 Fuel injector Balance/Open	Injector #1 disconnected or interconnect harness is open	Correct condition**
P0264	Cylinder #2 Fuel injector Circuit Low/SG	Injector #2 or interconnect harness shorted to chassis ground	Correct condition**
P0265	Cylinder #2 Fuel injector Circuit High	Injector #2 or interconnect harness shorted to battery power	Correct condition**
P0266	Cylinder #2 Fuel injector Balance/Open	Injector #2 disconnected or interconnect harness is open	Correct condition**
P0336	Crankshaft Angle Sensor Synchronization	Sensor or interconnect harness intermittent	Correct condition**
P0337	Crankshaft Angle Sensor Circuit/SG	Sensor or interconnect harness shorted to chassis ground	Correct condition**
P0339	Crankshaft Angle Sensor Intermittent/Erratic	Sensor or interconnect harness intermittent	Correct condition**
P0340	Camshaft Angle Sensor Synchronization	Sensor or interconnect harness intermittent	Correct condition**
P0341	Camshaft Angle Sensor Circuit/SG	Sensor or interconnect harness shorted to chassis ground	Correct condition**
P0342	Camshaft Angle Sensor Intermittent/Erratic	Sensor or interconnect harness intermittent	Correct condition**
P0480	Fan Relay Control Circuit	Relay erratic or intermittent	Correct condition*
P0484	Fan Relay Control Circuit High	Relay or interconnect harness shorted to battery power	Correct condition*
P0485	Fan Relay Control Circuit Low/SG/Open	Fan fuse has blown, fan relay removed, or interconnect harness shorted to chassis ground	Correct condition*

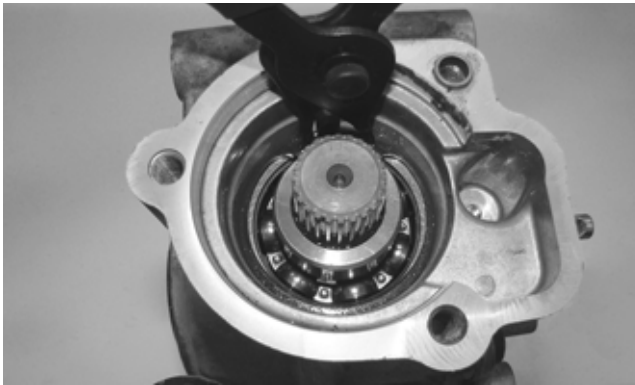

WC430

- Using the Pinion Gear/Shaft Removal Tool and a hammer, remove the pinion gear from the gear case housing.

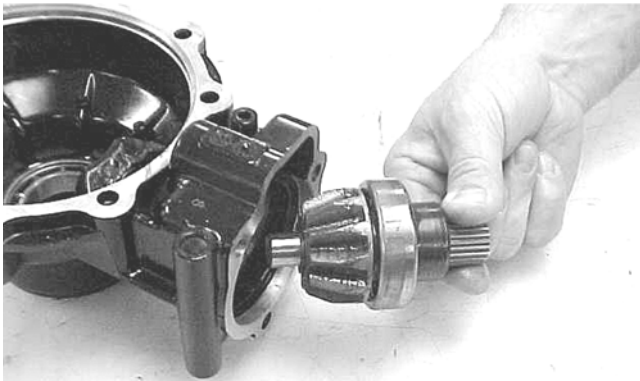

CC878

- Secure the pinion gear in a bearing puller; then remove the pinion bearing using a press. Account for a collar and a bearing.

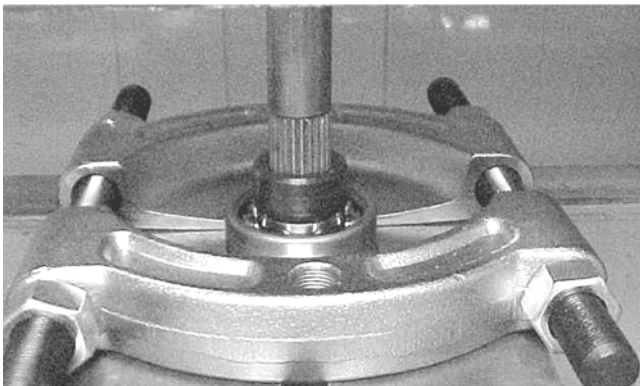

CC879

- Remove any reusable parts from the gear case housing; then discard the housing and lock collar.

### Assembling Pinion Gear

- Install the bearing onto the pinion shaft. Install the pinion shaft collar.

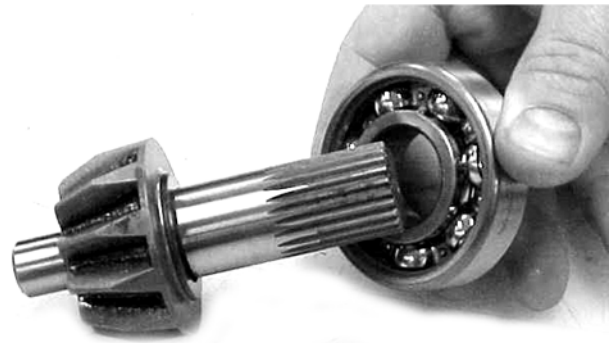

CC882

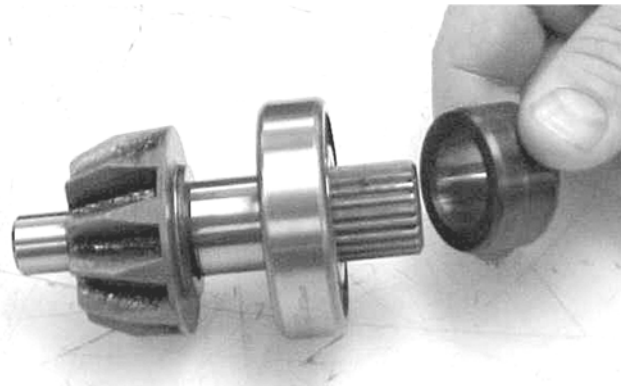

CC883

- Place the pinion assembly in a bearing puller; then install the bearing using a press.

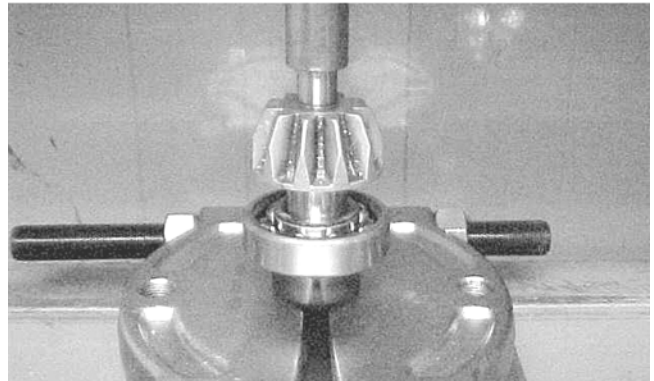

CC884

- Using a propane torch, heat the gear case housing to approximately 200° F; then install the pinion assembly.
- Install the internal snap ring with the sharp side directed away from the bearing.

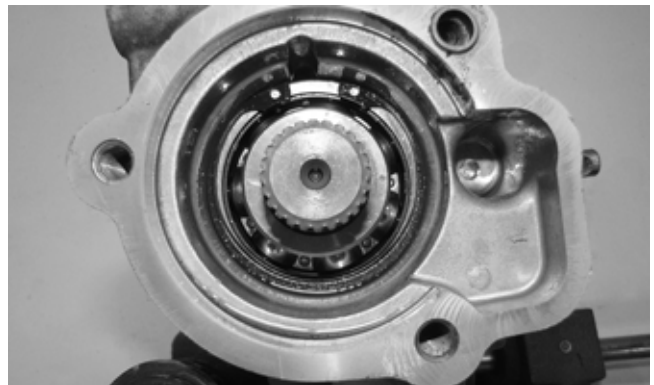

WC429

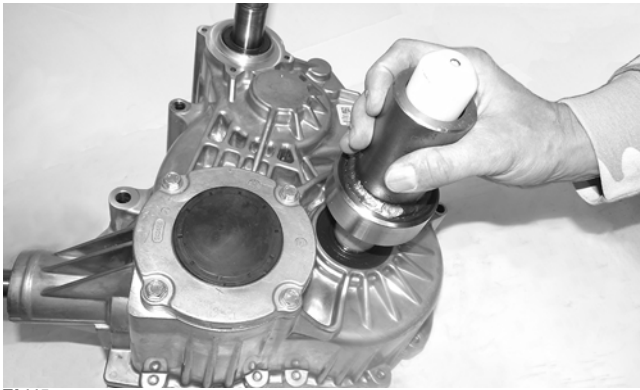

TA115

### Input (Driven Clutch) Seal

■NOTE: The transaxle does not need to be removed for this procedure.

1. Support the vehicle on an appropriate stand; then remove the left rear wheel, the outer clutch cover, the clutches, and the inner clutch cover.
2. Using an awl and a mallet, pry the seal from the case taking care not to damage the seal bore.



TA109

3. Wipe any oil or dirt from the seal area of the transaxle.
4. Using an appropriate seal installer and protector, install a new seal so it seats flush with the case (0.5 mm deep).



TA110

### Front Output Seal

■NOTE: The transaxle must be removed for this procedure.

1. Using an awl and a mallet, pry the seal from the case taking care not to damage the seal bore.



TA117

### CAUTION

Do not drive the awl too far or bearing damage will occur.

2. Wipe any oil or dirt from the seal area of the transaxle.
3. Tape the splined portion of the pinion shaft to protect the seal; then using an appropriate seal installer, install the front output seal (approximately 0.5-1.0 mm deep).

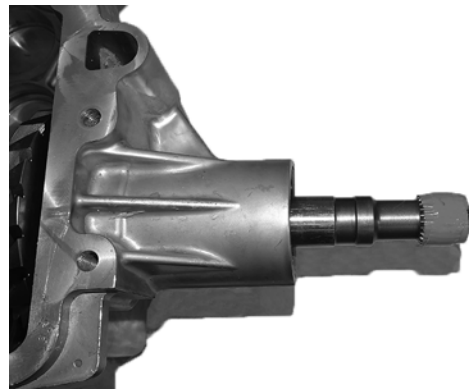

TA129

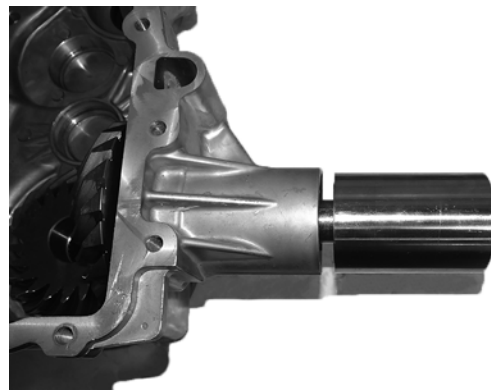

TA130

### Pinion Plug

■NOTE: The transaxle does not need to be removed for this procedure.

1. Support the vehicle on an appropriate stand; then remove the right rear wheel and axle.

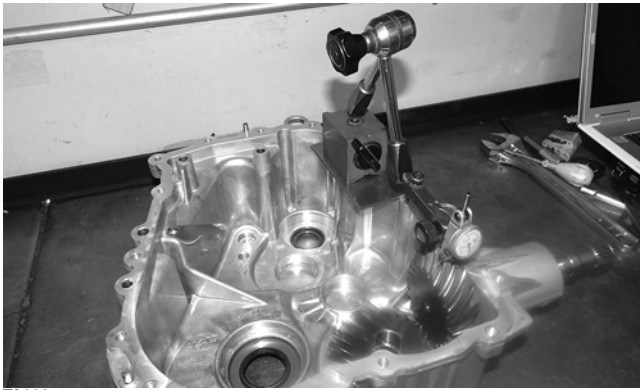

TA096

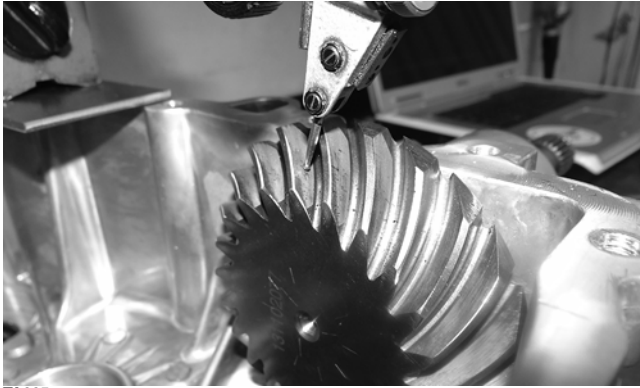

TA095

5. While pushing in on the front output shaft, and while rocking the shaft back and forth and note the maximum backlash reading on the gauge.

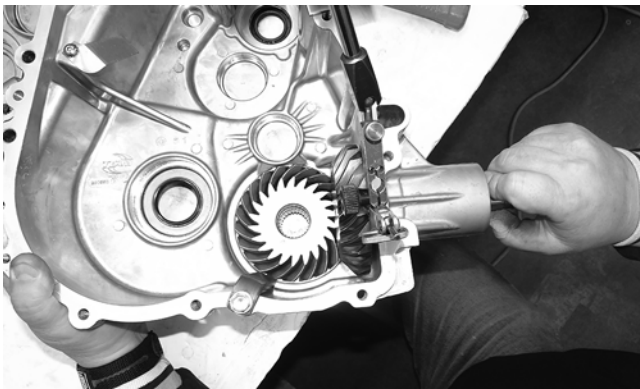

TA125

6. Acceptable backlash range is 0.076-0.241 mm (0.003-0.0095 in.).

■NOTE: If backlash measurement is within the acceptable range, no correction is necessary.

7. If backlash measurement is less than specified, remove the existing shim and install a new thicker shim (from shim kit).

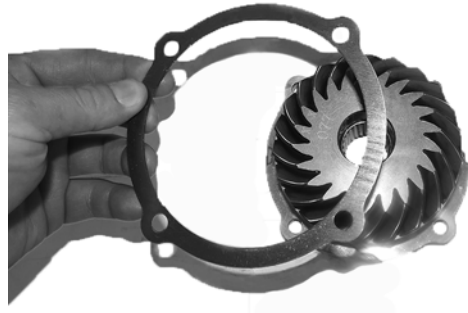

TA102

8. If backlash measurement is more than specified, remove the existing shim and install a thinner shim.

■NOTE: Continue to remove, measure, and install until backlash measurement is within tolerance. Note the following chart.

Backlash Measurement	Shim Correction
Under 0.076 mm (0.003 in.)	Increase Shim Thickness
At 0.076-0.241 mm (0.003-0.0095 in.)	No Correction Required
Over 0.241 mm (0.0095 in.)	Decrease Shim Thickness

9. Tape the splined portion of the pinion shaft to protect the seal; then using an appropriate seal installer, install the front output seal so it seats fully past the chamfer of the case.

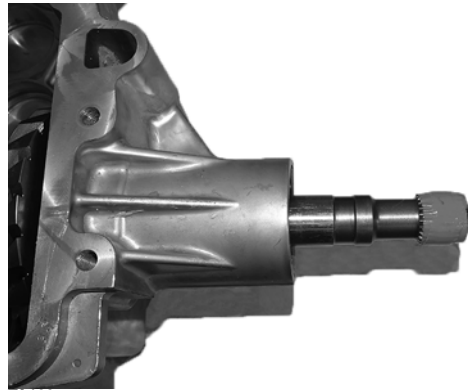

TA129

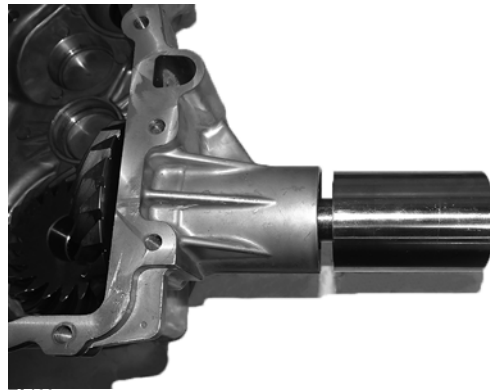

TA130

## ASSEMBLING HALVES

1. Install the intermediate shaft and idler shaft into the case only partially. Do not seat the shafts completely into the case at this time.

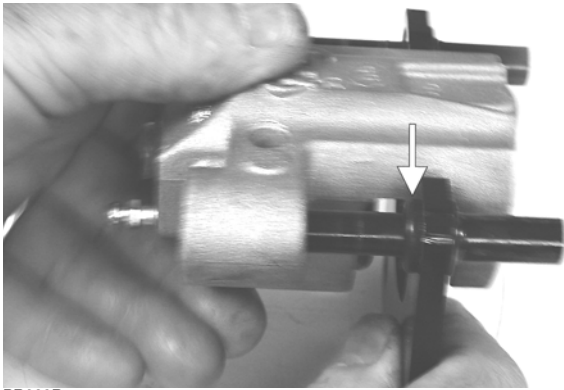

PR239B

■NOTE: The O-ring is used for shipping purposes and provides no function in operation.

- Cover the piston end of the housing with a shop towel; then keeping fingers clear of piston travel, apply compressed air to the fluid port to blow the piston free of the housing. Account for two seal rings in the housing.

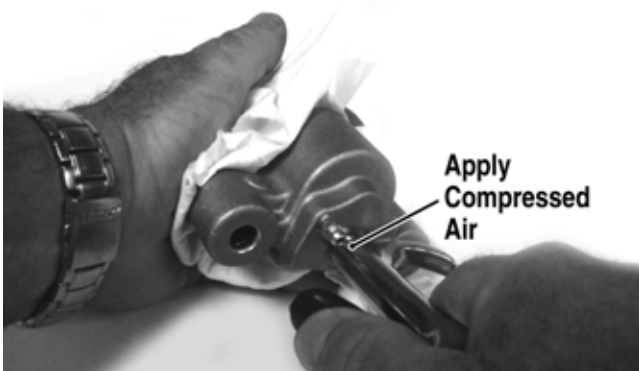

PR713A



PR715

**⚠ WARNING**

**Make sure to hold the towel firmly in place or the piston could be ejected from the housing causing injury.**

- Using an appropriate seal removal tool, carefully remove the seals from the brake caliper housing; then remove four O-rings from the brake caliper housing noting the location of the different sized O-rings. Discard all seals, O-rings, and crush washers.

**CLEANING AND INSPECTING**

- Clean all caliper components (except the brake pads) with DOT 4 brake fluid. Do not wipe dry.

- Inspect the brake pads for damage and excessive wear.

■NOTE: For measuring brake pads, see Periodic Maintenance/Tune-Up.

- Inspect the brake caliper housings for scoring in the piston bores, chipped seal ring grooves, or signs of corrosion or discoloration.
- Inspect the piston surface for scoring, discoloration, or evidence of binding or galling.
- Inspect the caliper holder for wear or bending.

**ASSEMBLING/INSTALLING**

- Install new seals into the brake caliper housing and apply a liberal amount of DOT 4 brake fluid to the cylinder bore of the housing, seals, and brake piston.

**CAUTION**

**Make sure the seals are properly in place and did not twist or roll during installation.**



PR715

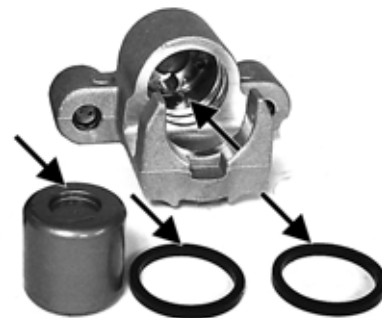

PR717A

- Press the piston into the caliper housing using hand pressure only. Completely seat the piston; then wipe off any excess brake fluid.

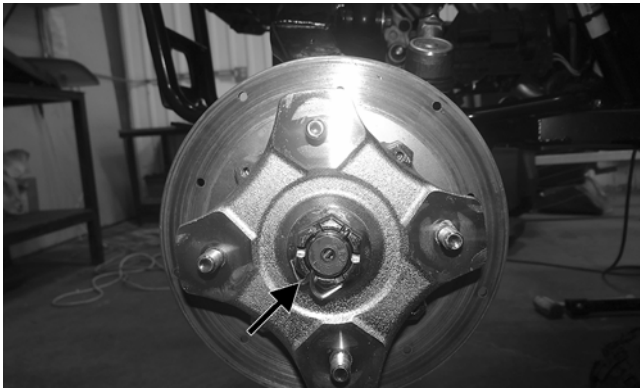

WT328A

■NOTE: During assembly, new cotter pins should always be used.

■NOTE: If the cotter pin cannot be inserted due to misalignment of the hole and the slots in the nut, always tighten the nut until it is properly aligned.

13. Using a new “patch-lock” cap screw and existing washer, secure the shock to the upper A-arm. Tighten to 25 ft-lb.

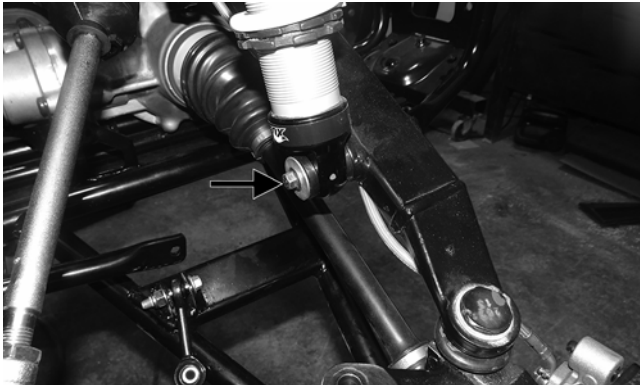

WT498A

14. Tighten the cap screw securing the upper A-arm to the frame to 35 ft-lb.

15. Using new “patch-lock” cap screws, secure the brake caliper to the brake disc. Tighten to 20 ft-lb.

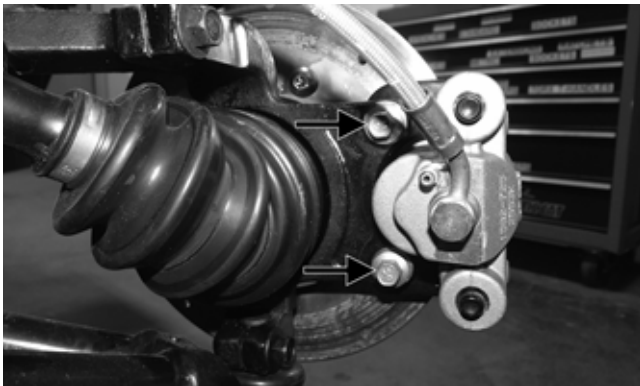

WT287A

16. Install the wheels and tighten the wheel nuts in 20 ft-lb increments to a final torque of 40 ft-lb (steel wheel), 60 ft-lb (aluminum wheel w/black nuts), or 80 ft-lb (aluminum wheel w/chrome nuts).

17. Install the front bumper; then remove the vehicle from the support stand.

## Rear A Arms

### REMOVING

1. Lift and support the vehicle on a support stand that allows access to the rear suspension with the rear tires off of the floor. Remove the wheels.

■NOTE: The upper A-arm can be removed without removing the hub or the knuckle. If it is the technician’s objective to only remove the upper A-arm, proceed to step 5.

2. Remove and discard the “patch-lock” cap screws securing the brake caliper to the hub.

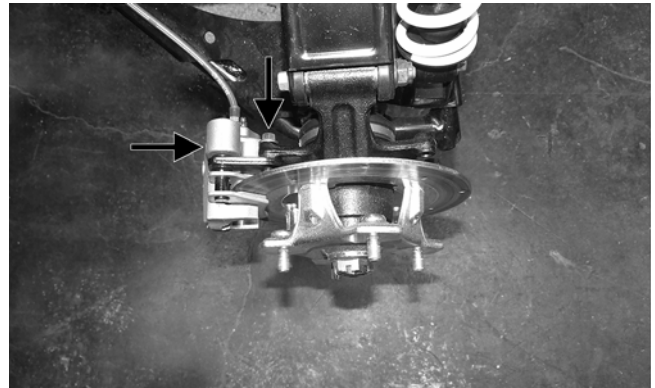

WT418A

3. Remove and discard the cotter pin from the hub nut; then remove nut and hub.

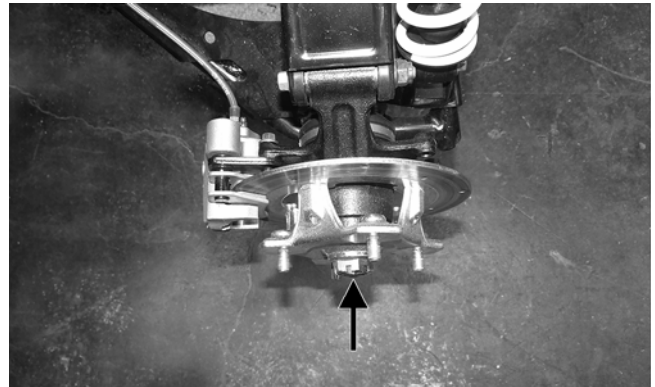

WT418B

4. Remove the lower shock cap screw and discard the nut.



WT417A

CLICK HERE TO **DOWNLOAD** THE COMPLETE MANUAL

- Thank you very much for reading the preview of the manual.
- You can download the complete manual from: [www.heydownloads.com](http://www.heydownloads.com) by clicking the link below



- Please note: If there is no response to CLICKING the link, please download this PDF first and then click on it.

CLICK HERE TO **DOWNLOAD** THE COMPLETE MANUAL