

SHOP MANUAL

ALLIS-CHALMERS

MODELS D-19

D-19 DIESEL

Tractor serial number is stamped on the left front of torque tube. Engine serial number is stamped on the center left side of the engine block. Transmission serial number is stamped on the lower right hand corner of rear face of transmission case.

The D-19 tractor is available with an LP-Gas, gasoline or a turbo-charged diesel engine in dual wheel tricycle, single wheel tricycle or adjustable axle versions.

INDEX (By Starting Paragraph)

<p>BELT PULLEY 140</p> <p>BRAKES</p> <p style="padding-left: 20px;">Adjustment 137</p> <p style="padding-left: 20px;">Brakes R&R 138</p> <p>CARBURETOR</p> <p style="padding-left: 20px;">Gasoline 60</p> <p style="padding-left: 20px;">LP-Gas 61</p> <p>CLUTCH</p> <p style="padding-left: 20px;">Engine clutch 108</p> <p style="padding-left: 20px;">Engine clutch shaft 112</p> <p style="padding-left: 20px;">"Power-Director" clutch 115</p> <p>COOLING SYSTEM</p> <p style="padding-left: 20px;">Water pump 98</p> <p style="padding-left: 20px;">Radiator 97</p> <p>DIESEL FUEL SYSTEM</p> <p style="padding-left: 20px;">Energy cells 89</p> <p style="padding-left: 20px;">Filters and bleeding 76</p> <p style="padding-left: 20px;">Injection pump 86</p> <p style="padding-left: 20px;">Injection pump gears 46</p> <p style="padding-left: 20px;">Nozzles 78</p> <p style="padding-left: 20px;">Quick checks 75</p> <p>DIFFERENTIAL</p> <p style="padding-left: 20px;">Adjustment 128</p> <p style="padding-left: 20px;">R&R and overhaul 129</p> <p>ELECTRICAL 101</p> <p>ENGINE (DIESEL)</p> <p style="padding-left: 20px;">Assembly—R&R 29</p> <p style="padding-left: 20px;">Cam followers 38</p> <p style="padding-left: 20px;">Camshaft 47</p> <p style="padding-left: 20px;">Connecting rods & bearings 52</p> <p style="padding-left: 20px;">Crankshaft and bearings 53</p> <p style="padding-left: 20px;">Cylinder head 31</p> <p style="padding-left: 20px;">Cylinder sleeves 51</p> <p style="padding-left: 20px;">Flywheel 56</p> <p style="padding-left: 20px;">Front oil seal 41</p> <p style="padding-left: 20px;">Injection timing 86</p> <p style="padding-left: 20px;">Main bearings 53</p> <p style="padding-left: 20px;">Oil pan 57</p> <p style="padding-left: 20px;">Oil pump 58</p> <p style="padding-left: 20px;">Piston pins 51A</p> <p style="padding-left: 20px;">Piston & rod removal 49</p>	<p style="padding-left: 20px;">Pistons and rings 51</p> <p style="padding-left: 20px;">Rear oil seal 55</p> <p style="padding-left: 20px;">Rocker arms 40</p> <p style="padding-left: 20px;">Speed adjustments 88</p> <p style="padding-left: 20px;">Tappet gap 40A</p> <p style="padding-left: 20px;">Timing gear cover 41</p> <p style="padding-left: 20px;">Timing gears 43</p> <p style="padding-left: 20px;">Turbo-charger 90</p> <p style="padding-left: 20px;">Valve guides 35</p> <p style="padding-left: 20px;">Valves & valve seats 33</p> <p style="padding-left: 20px;">Valve rotators 33</p> <p style="padding-left: 20px;">Valve seals 33</p> <p style="padding-left: 20px;">Valve springs 37</p> <p style="padding-left: 20px;">Valve timing 42</p> <p>ENGINE (NON-DIESEL)</p> <p style="padding-left: 20px;">Assembly—R&R 28</p> <p style="padding-left: 20px;">Cam followers 38</p> <p style="padding-left: 20px;">Camshaft 47</p> <p style="padding-left: 20px;">Connecting rods & bearings 52</p> <p style="padding-left: 20px;">Crankshaft & bearings 53</p> <p style="padding-left: 20px;">Cylinder head 30</p> <p style="padding-left: 20px;">Cylinder sleeves 50</p> <p style="padding-left: 20px;">Flywheel 56</p> <p style="padding-left: 20px;">Front oil seal 41</p> <p style="padding-left: 20px;">Ignition timing 103</p> <p style="padding-left: 20px;">Main bearings 53</p> <p style="padding-left: 20px;">Oil pan 57</p> <p style="padding-left: 20px;">Oil pump 58</p> <p style="padding-left: 20px;">Piston pins 51A</p> <p style="padding-left: 20px;">Piston & rod removal 49</p> <p style="padding-left: 20px;">Pistons & rings 50</p> <p style="padding-left: 20px;">Rear oil seal 55</p> <p style="padding-left: 20px;">Rocker arms 39</p> <p style="padding-left: 20px;">Spark plugs 101</p> <p style="padding-left: 20px;">Speed adjustment 95</p> <p style="padding-left: 20px;">Tappet gap 39A</p> <p style="padding-left: 20px;">Timing gear cover 41</p> <p style="padding-left: 20px;">Timing gears 43</p> <p style="padding-left: 20px;">Valve guides 34</p> <p style="padding-left: 20px;">Valves & valve seats 32</p> <p style="padding-left: 20px;">Valve rotators 32</p> <p style="padding-left: 20px;">Valve seals 32</p> <p style="padding-left: 20px;">Valve springs 36</p> <p style="padding-left: 20px;">Valve timing 42</p> <p>FINAL DRIVE & DIFFERENTIAL</p> <p style="padding-left: 20px;">Bevel gears adjust 130</p> <p style="padding-left: 20px;">Bull gear renew 133</p>	<p style="padding-left: 20px;">Bull pinion bearings adjust 132</p> <p style="padding-left: 20px;">Bull pinion renew 132</p> <p style="padding-left: 20px;">Differential overhaul 129</p> <p style="padding-left: 20px;">Final drive units R&R 132</p> <p style="padding-left: 20px;">Wheel axle shafts 134</p> <p>FRONT SYSTEM</p> <p style="padding-left: 20px;">Adjustable axle 5</p> <p style="padding-left: 20px;">Dual wheel tricycle 3</p> <p style="padding-left: 20px;">Manual steering 11</p> <p style="padding-left: 20px;">Power steering 17</p> <p style="padding-left: 20px;">Single wheel tricycle 1</p> <p>GOVERNOR (NON-DIESEL)</p> <p style="padding-left: 20px;">Adjustment 95</p> <p style="padding-left: 20px;">Overhaul 96</p> <p>IGNITION SYSTEM</p> <p style="padding-left: 20px;">Distributor 102</p> <p style="padding-left: 20px;">Ignition timing 103</p> <p>LP-GAS SYSTEM</p> <p style="padding-left: 20px;">Adjustments 61</p> <p style="padding-left: 20px;">Filter 68</p> <p style="padding-left: 20px;">Regulator 69</p> <p>"POWER-DIRECTOR"</p> <p style="padding-left: 20px;">Clutch 115</p> <p style="padding-left: 20px;">Shafts and gears 119</p> <p>POWER LIFT SYSTEM</p> <p style="padding-left: 20px;">Pump 157</p> <p style="padding-left: 20px;">Testing 151</p> <p style="padding-left: 20px;">Work cylinders 167</p> <p>POWER TAKE-OFF 145</p> <p>STEERING GEAR</p> <p style="padding-left: 20px;">(Manual) 11</p> <p style="padding-left: 20px;">(Power) 17</p> <p>TRANSMISSION</p> <p style="padding-left: 20px;">Bevel pinion shaft 125</p> <p style="padding-left: 20px;">Countershaft 126</p> <p style="padding-left: 20px;">Input shaft 124</p> <p style="padding-left: 20px;">Reverse idler 127</p> <p style="padding-left: 20px;">Shifter assembly 122</p>
--	---	---

CLICK HERE TO **DOWNLOAD** THE COMPLETE MANUAL

- Thank you very much for reading the preview of the manual.
- You can download the complete manual from: www.heydownloads.com by clicking the link below



- Please note: If there is no response to CLICKING the link, please download this PDF first and then click on it.

CLICK HERE TO **DOWNLOAD** THE COMPLETE MANUAL

POWER STEERING GEAR UNIT

The worm and sector type gear unit is contained in the front support casting (44—Fig. AC16). Lubricating oil for the gear unit is also used as power steering fluid. Oil level should be maintained at $\frac{5}{8}$ -inch above the sector (steering) gear with type "A" automatic transmission fluid.

25. ADJUSTMENTS. The gear unit is provided with two adjustments: Rack mesh position is adjusted by the number of shims between the front support casting and the rack adjusting block (48—Fig. AC16). Steering shaft bearing end play is also adjustable by varying the number of shims (4—Fig. AC17) between the sector gear (5) and flat washer (3) on single front wheel models or by varying the number of shims (60—Fig. AC16) between the bearing retainer (62) and the front support casting (44) on dual wheel tricycle and adjustable front axle models. However, these adjustments are more in the nature of assembly procedure when overhauling front support assembly than routine adjustment to provide better power steering operation. Therefore, adjustments will be discussed under reassembly of gear unit in front support. Refer to paragraph 27.

26. R&R FRONT SUPPORT (GEAR UNIT). Support front end of tractor. Unbolt and remove single front wheel fork and wheel assembly, dual wheel tricycle pedestal and wheel assembly or adjustable front axle support casting. On adjustable front axle models, drive pin from center steering arm and remove steering arm from shaft. Drain power steering fluid from front support on all models. Then remove front support assembly as outlined in paragraph 21.

Reverse removal procedures to re-install front support. Refill to $\frac{5}{8}$ -inch above sector gear with type "A" automatic transmission fluid. Start engine and cycle system several times after assembly is completed to bleed any trapped air from system. Check fluid level and add fluid as necessary.

27. OVERHAUL FRONT SUPPORT. Remove power steering tubes from ram cylinder and power steering control valve. Unbolt and remove ram cylinder as outlined in paragraph 24.

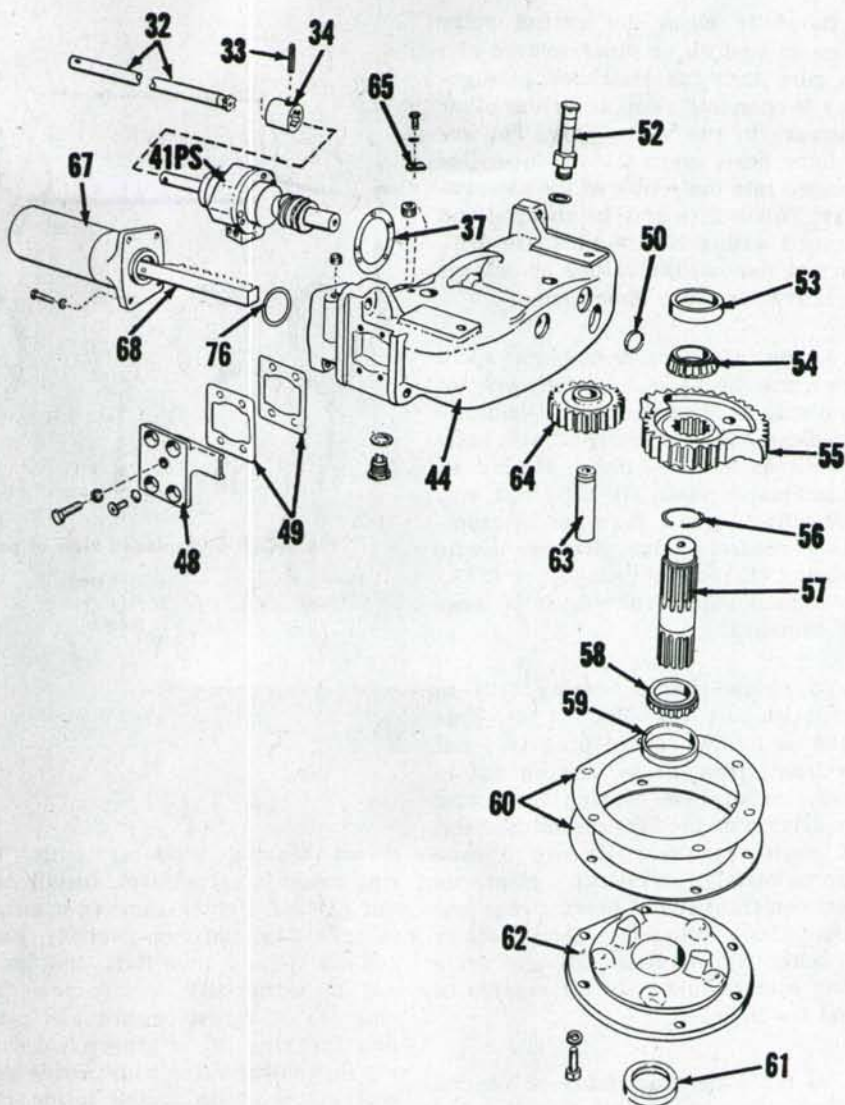

Fig. AC16 — Partially exploded view of the power steering front support. For exploded views of the control valve unit (41PS) and ram (67), refer to Fig. AC14 and Fig. AC15 respectively.

32. Lower steering shaft	48. Rack adjusting block	54. Bearing cone	61. Oil seal
33. Roll pin	49. Rack adjusting shims (0.005 & 0.003)	55. Steering gear	62. Shaft retainer
34. Splined coupling	50. Plug	56. Snap ring	63. Idler gear shaft
37. Gasket	52. Breather	57. Steering shaft	64. Idler gear
41PS. Steering control valve and worm-shaft unit	53. Bearing cup	58. Bearing cone	65. Lock plate
44. Front support		59. Bearing cup	67. Steering ram
		60. Shims (0.005 & 0.010)	68. Rack
			76. "O" ring

Unbolt and remove control valve and wormshaft unit as outlined in paragraph 22.

Unbolt bearing retainer (9—Fig. AC17) on single front wheel models or (62—Fig. AC16) on other models and remove shaft and sector gear assembly from front support. Be careful not to lose or damage shims (60—Fig. AC16) on dual wheel tricycle and adjustable axle models.

Remove idler shaft lock (65—Fig. AC16), then pull idler shaft from

front support. (Top end of shaft has threaded hole to facilitate pulling shaft from casting.) Withdraw idler gear through bottom opening in casting.

Thoroughly clean front support casting prior to reassembly of steering gear unit. As front support is used for power steering fluid reservoir, cleanliness is of utmost importance. Following procedure should be observed in inspecting and renewing parts and in reassembly of unit:

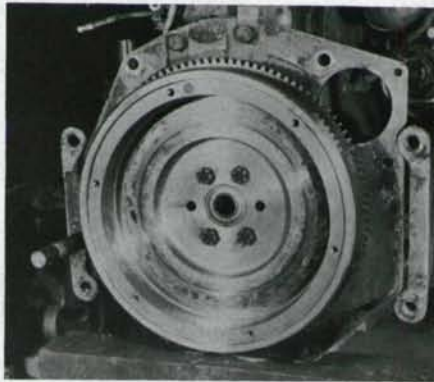

Fig. AC29 — D-19 diesel and non-diesel flywheel is retained to crankshaft by four cap screws and two dowel pins. Installation of flywheel is possible in one position only.

FLYWHEEL

All Engines

56. REMOVE AND REINSTALL. To remove flywheel, first remove engine clutch as outlined in paragraph 109. The flywheel is retained to the engine crankshaft with four unequally spaced cap screws and two dowel pins. See Figs. AC28 and AC29. To renew flywheel ring gear, flywheel must be removed from crankshaft. Inspect clutch friction surface and crankshaft rear oil seal surface of flywheel. Drive flywheel ring gear from flywheel. Heat new ring gear evenly until it will fit over flywheel and install ring gear with tooth bevel to front. Clutch pilot bearing in flywheel is a sealed unit.

When reinstalling flywheel, tighten retaining cap screws to a torque of 95-105 Ft.-Lbs. Complete reassembly by reversing disassembly procedure.

OIL PAN (SUMP)

All Engines

57. REMOVE AND REINSTALL. To remove the oil pan, it is first necessary to remove the front support as outlined in paragraph 12 or 21.

After removing front support, remove the four cap screws retaining lower portion of timing gear cover to pan, then remove cap screws holding pan to cylinder block. Pan generally will be tightly sealed to block and care should be taken in prying pan loose in order not to distort rear arch and gasket sealing surface of pan.

As gasket between engine front plate and cylinder block will probably be damaged when pan is re-

moved and renewal of complete gasket would require removal of engine front plate, cut lower portion of new gasket to fit end of pan and then apply this cut portion of the gasket to the front plate with gasket cement. Use a heavy gasket sealer where gasket meets cylinder block. Apply gasket sealer to rubber sealing ring around crankshaft rear oil seal retainer and to both sides of pan gasket. Stick gasket to cylinder block and carefully lift pan in place after being sure any distorted part of pan sealing surface has been straightened. Install cap screws retaining pan to cylinder block finger tight; then, apply gasket sealer to the four cap screws retaining pan to front cover and install these cap screws tightly. Starting at front of pan, tighten all cap screws to a torque of 18-21 Ft.-Lbs. Reinstall front support by reversing removal procedures. On power steering models, start engine and cycle power steering system several times to bleed any trapped air from system. Check power steering fluid level and add type "A" automatic transmission fluid as necessary.

OIL PUMP AND RELIEF VALVES

All Engines

58. R&R AND OVERHAUL PUMP. Removal procedure will be self-evident after removal of oil pan as outlined in paragraph 57.

To disassemble the removed pump, refer to Fig. AC30 and proceed as follows: Remove screen (13) and cover (12). Extract pin (2), then press shaft (9) out of gear (1) and body (4). To remove either pump gear (11), press shaft out of gear.

Renew any parts which are excessively worn, scored or are in any way questionable. Pump gears (11) should have not more than 0.020 back lash or more than 0.006 end play. Pump body and/or shafts should be renewed if shaft to body clearance exceeds 0.004.

When reinstalling oil pump on diesel engines, be sure that slot in oil pump gear drive engages drive pin on operation (hour) meter drive shaft. Tighten the pump retaining cap screw to a torque of 18-21 Ft.-Lbs. NOTE: Flange on pump does not fit against cylinder block.

On non-diesel engines, turn crankshaft until piston for number one cylinder is at TDC on compression stroke (Refer to Fig. AC79). Turn the dis-

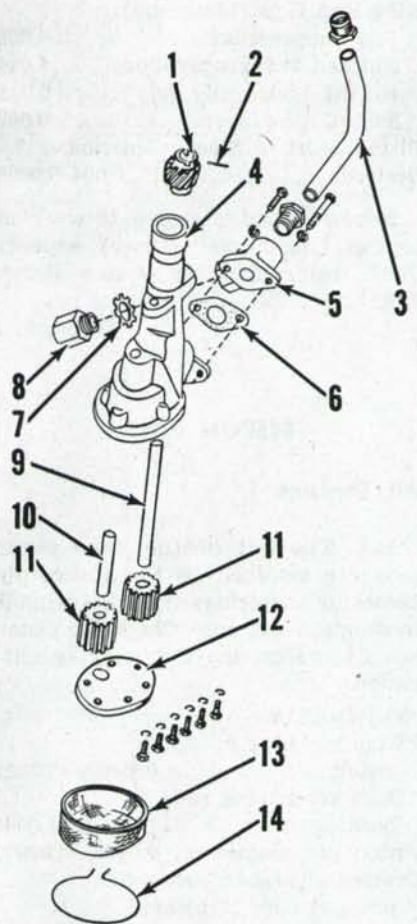

Fig. AC30 — Exploded view of D-19 diesel and non-diesel oil pump assembly. Relief valve (8) is non-adjustable and is used to prevent surge pressures only. Normal oil pressure is controlled by relief valve shown in Fig. AC31.

- | | |
|-------------------|------------------|
| 1. Drive gear | 8. Relief valve |
| 2. Pin | 9. Drive shaft |
| 3. Discharge tube | 10. Driven shaft |
| 4. Pump body | 11. Pump gears |
| 5. Adapter flange | 12. Cover plate |
| 6. Gasket | 13. Screen |
| 7. Lock washer | 14. Retainer |

tributor rotor until it points toward the number one cylinder terminal on distributor cap and breaker points are just open. Install pump with slot in pump drive gear engaging drive tang on distributor drive shaft. NOTE: The driving slot and tang are off-set from center line of shafts. Tighten pump retaining cap screw to 18-21 Ft.-Lbs. torque. Check ignition timing as outlined in paragraph 103.

59. RELIEF VALVES. Two oil pressure relief valves are used in both diesel and non-diesel engines. The relief valve (8—Fig. AC30) on the oil pump discharge tube adapter is non-adjustable and should by-pass oil directly into the sump at approximately 80 psi. As this is well above normal oil pressure of 25-40 psi, valve (8) opens only due to surge pressure when oil is cold.

Paragraph 91

91. OVERHAUL. When servicing turbocharger as originally installed on early tractors, it is advisable to use special tools available from Kent-Moore Organization, Inc. Some of the early turbochargers have been changed by installing later type parts and the special tools are not required. Attention will be called to difference in service procedure.

Remove turbocharger unit as outlined in paragraph 90. Scribe a mark across turbine housing (22—Fig. AC53), clamp (20), bearing housing (13) and compressor housing (1) to aid reassembly and proceed as follows: Remove nut (19) and clamp (20); then, remove turbine housing (22). Remove cap screws attaching bearing housing (13) to compressor housing (1) and remove compressor housing. Hold blades of turbine wheel (18) with shop towel; remove nut (3) and washer (4) from turbine shaft (L.H. threads). On early models, impeller (5E) is a tight fit on turbine shaft (18) and shaft must be pressed out of impeller as shown in Fig. AC54. On later models, impeller (5—Fig. AC53) will slide easily off shaft.

CAUTION: On all models, do not allow turbine wheel and shaft to drop when impeller is removed.

Remove snap ring (6), then remove oil retainer plate (7 or 7E). On early type, retainer plate (7E) must be pressed out of bore using the Kent-Moore special tool. On later type (7), a 3/4-inch driver can be used as shown in Fig. AC55 to remove seal and retainer plate (7—Fig. AC53), mating piece (10) and bearing (12).

It is recommended that late type seal (7) and mating ring (10) be renewed each time turbocharger is disassembled for service. The early type turbocharger can be changed to later type by installing new type parts (5, 7, 10 and 11).

Clean all parts except late type oil seal (7) by washing in kerosene or diesel fuel. A nylon bristle brush may be used to clean carbon from parts.

CAUTION: Do not use wire brush, caustic cleaners, etc., on turbocharger parts. Inspect all parts for burring, eroding, nicks, breaks, scoring, excessive carbon build-up or other defects and renew all questionable parts.

On early type turbocharger, compressor impeller (5E) should be press fit on turbine shaft (18). Thrust surfaces of spacer (11E) must not be rough. Inspect grooves in spacer (11E) for excessive wear and make certain

carbon is removed from bottom of grooves. Check O.D. of retainer plate (7E) for nicks that would damage "O" ring (9). Inspect bore in retainer plate for grooving caused by seal rings (10) sticking and turning with shaft. Clean the bore chamfer to ease installation of seals (10E).

On late type turbocharger, inspect seal (7) carefully if the seal is to be reinstalled. The carbon face insert should move freely in and out and must not be scored or excessively worn. Mating ring (10) should not show evidence of wear or scuffing on either side. Remove any carbon from seal contact side. Examine sleeve (11) for burrs, scoring and wear. The sleeve is precision ground and any defect will distort the mating ring and cause seal leakage.

On all models, pay particular attention to blades of turbine wheel (18) and compressor impeller (5 or 5E) and to bushing (12). If bushing (12) and/or turbine shaft is worn excessively, the blades of turbine wheel and compressor impeller may have rubbed against housings. Shaft clearance in bushing should be measured at compressor impeller end of shaft using a dial indicator with unit assembled. If indicated clearance exceeds 0.022, bushing (12) and/or shaft (18) should be renewed. Inspect bore in bearing housing (13) for evidence of stuck seal ring (17). If seal ring was sticking in shaft groove, the bore in housing will be grooved and should be renewed. Make certain that seal bore chamfer is clean and smooth to ease installation of shaft and seal ring.

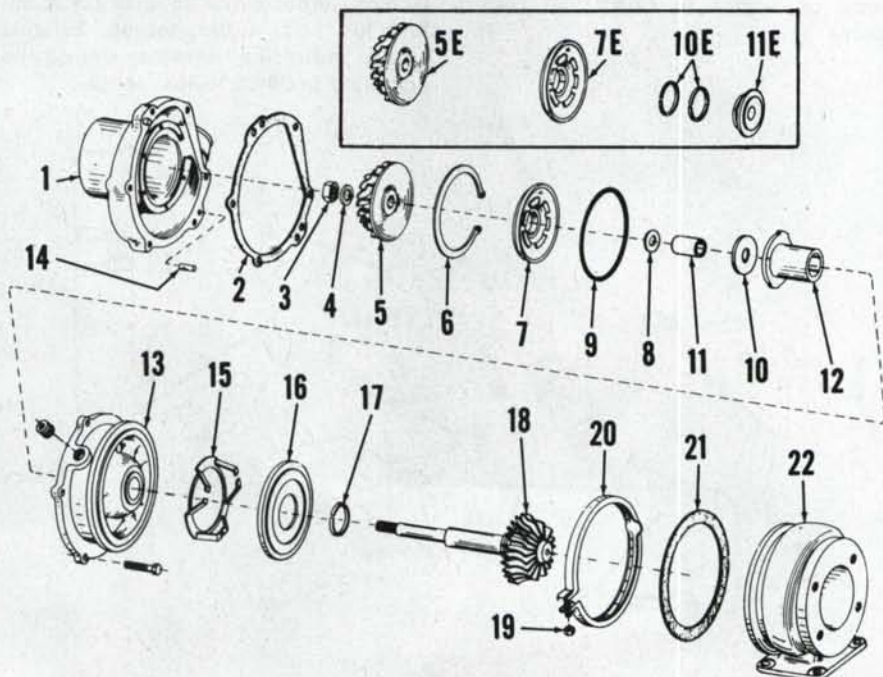

Fig. AC53—Exploded view of Thompson turbocharger unit used on diesel engines. Inset shows parts that are different on earlier unit.

- | | | |
|-------------------------------|--------------------------|---------------------------|
| 1. Compressor housing | 7E. Oil retaining plate | 11E. Turbine shaft spacer |
| 2. Gasket | 8. Shims | 12. Bearing |
| 5 & 5E. Impeller | 9. "O" ring | 13. Bearing housing |
| 6. Snap ring | 10. Mating ring | 14. Groove pins |
| 7. Oil seal & retaining plate | 10E. Turbine shaft seals | 15. Spring ring |
| | 11. Shaft sleeve | 16. Turbine wheel |
| | | 17. Turbine shaft seal |
| | | 18. Turbine wheel & shaft |
| | | 20. Clamp |
| | | 21. Gasket |
| | | 22. Turbine housing |

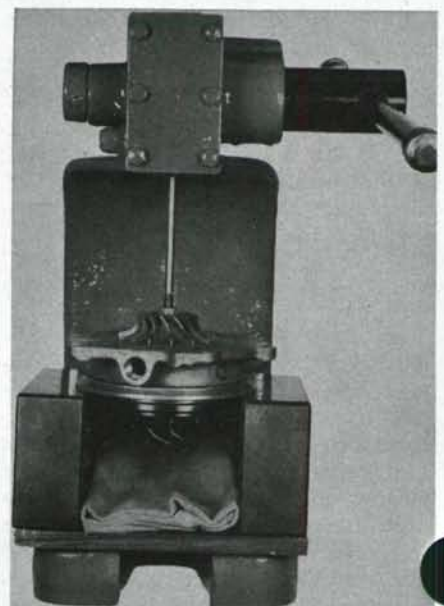

Fig. AC54—View showing method of removing early type impeller using special Kent-Moore tool.

"POWER DIRECTOR"

The "Power-Director" (See Fig. AC90) consists of two multiple disc wet type clutch packs contained in a common housing that is splined to the transmission input shaft. A reduction gear drive in front of the clutch housing turns the discs of the front clutch pack through a hollow shaft. The engine clutch shaft passes through the hollow shaft and turns the discs of the rear clutch pack at engine speed. Both clutch packs are controlled by a single lever and over-center type linkage. With the control lever in the forward position, the rear clutch pack is engaged and the clutch housing and transmission input shaft are turned at engine speed. When the lever is in the rear position, the front clutch pack is engaged and the clutch housing and transmission input shaft are turned at a reduced speed. Placing the control lever in center position disengages both clutch packs.

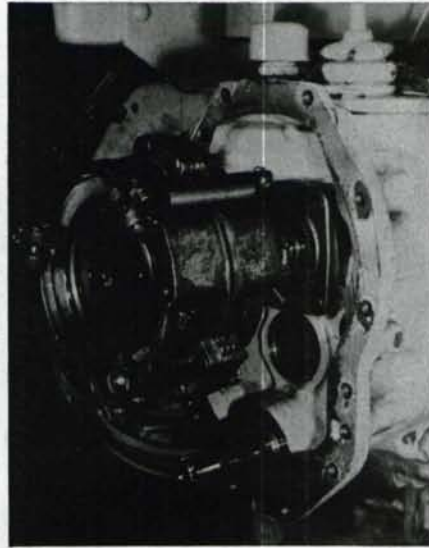

Fig. AC90 — View showing "Power-Director" clutch unit on transmission input shaft.

The "Power-Director" clutch packs are lubricated by oil from a pump in the bottom of the torque housing. The pump is driven by the front power take-off shaft. Oil from the pump passes through lines to an external filter and then to the clutch packs and reduction gear drive for lubrication of these units. The "Power-Director" and hydraulic oil sumps are connected. Sump capacity is approximately 22 quarts of SAE 20-20W non-detergent service "ML" motor oil. Oil level is checked with the hydraulic lift arms lowered and any remote cylinders retracted. Run engine at high idle speed for at least three minutes, shut engine off and immediately check oil level on dipstick.

New clutch assemblies are provided with three 0.090 stacks of shims (51A & 51B) between each housing and center plate and three 0.025 stacks of shims (53) between the two center plates. Thus, the total height of the shim packs is 0.205 and this total height must be maintained when adjusting the clutch to avoid changing clutch housing dimensions. For any thickness of shims added or removed from the shim stacks between the housing and center plate of either clutch pack, a like thickness must be removed or added to the shim stacks between the two center plates.

To gain access to the clutch packs to check clutch adjustment, first disconnect the filter lines (5 & 6—Fig. AC92) from the elbow fittings on the clutch cover (7); then remove filter and line assembly as a unit. Remove the two cap screws (8) and the quadrant (4) from clutch cover; then remove cover from clutch housing. Pull relief valve body (See Fig. AC93) from oil lines.

"POWER-DIRECTOR" CLUTCH

115. CLUTCH ADJUSTMENT. Refer to Fig. AC91. Clutch plate pressure is applied through a spring (Belleville) washer (46) that is located between the pre-load plate (45) and pressure plate (47) of each clutch pack. The spring washer must be compressed 0.042 to 0.048 inch when clutch pack is engaged. If compression is less, slippage of clutch will result. If compression of spring washer is greater than 0.048, clutch pack will not release properly. Adjustment is provided with shim packs (51A, 51B and 53) placed between the clutch housings and adjoining center plates and between the center plates.

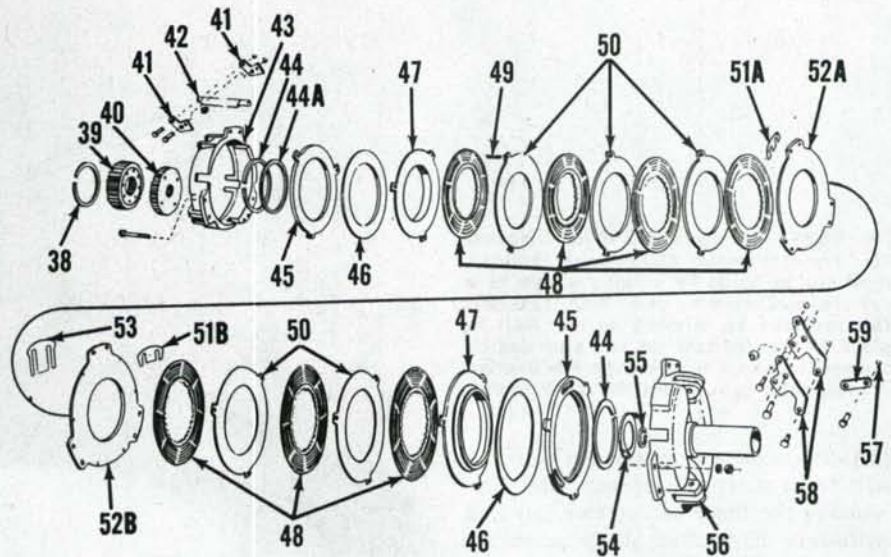

Fig. AC91 — Exploded view of "Power-Director" clutch assembly. Unit is equipped with more drive and driven plates than shown. Refer to text.

- | | | | |
|---------------------------|----------------------------|--|--------------------------|
| 38. Snap ring | 44. Snap ring | 49. Clutch releasing spring | 54. Thrust washer |
| 39. Front hub | 44A. Pressure plate spacer | 50. Clutch plate | 55. Snap ring |
| 40. Rear hub | 45. Pre-load plate | 51A & 51B. Outer shims (0.010 & 0.015) | 56. Rear housing |
| 41. Release lever (front) | 46. Pressure washer | 52A & 52B. Center plates | 57. Snap ring |
| 42. Clutch link | 47. Pressure plate | 53. Center shims (0.010 & 0.015) | 58. Release lever (rear) |
| 43. Front housing | 48. Clutch splined disc | | 59. Release lever link |

tor for pushing rear wheel from tapered hub. Disconnect lines from hydraulic control valve; then, unbolt and remove valve and manifold as a unit from transmission rear top cover. Unbolt and remove PTO output shaft and bearing retainer from rear face of lift shaft housing. Remove pins from lift pistons and hydraulic lift shaft pivot points. Unbolt and remove lift shaft housing from rear face of transmission housing. Remove seat assembly. Unbolt and remove transmission rear top cover.

Remove cap at inner end of rear axle and remove cap screw and pinned washer from inner end of rear axle. Remove rear axle outer bearing retainer. Remove final drive compartment magnetic plug to prevent damage to plug. Support weight of bull gear and buck up between gear and outer wall of bull gear compartment. Place porta-power ram or hydraulic jack between inner end of rear axle to be removed and opposite wall of differential compartment and press axle out of inner bearing cone and bull gear. Outer bearing cup will be pushed out with axle. CAUTION: When pressing rear axle out, be sure jack or ram is supported by opposite wall of differential compartment and not by inner end of opposite rear axle or cap covering inner end of axle.

Outer bearing cone may now be removed from axle shaft and outer seal from bearing retainer. To remove inner bearing cone, lift bull gear as far as possible and work cone out between bull gear and inner wall of bull gear compartment. (Bull gear cannot be removed from compartment unless bull pinion shaft is removed). Drive inner bearing cup out towards bull gear and work cup out between bull gear and inner wall of bull gear compartment.

Reverse removal procedures to re-install rear axle and bearings. Use all new "O" rings and gaskets during reassembly. Apply sealer to both sides of lift shaft housing gasket. To pull axle through the inner bearing cone, remove roll pin (17A—Fig. AC111) from washer (17) and use 2½ inch cap screw with washer to pull axle until the long cap screw bottoms in axle; then, use original cap screw (18) to complete the operation. Remove cap screw, drive the pin (17A) back into washer (17) and reinstall washer with pin inserted into off-center hole in inner end of axle shaft. Install cap screw (18) and tighten

to a torque of 160-170 Ft.-Lbs. Apply No. 3 Permatex or similar sealer to rim of cap (19) before installing cap at inner end of axle shaft.

136. R&R REAR AXLE HOUSING. To remove a rear axle housing, it is first necessary to remove the rear axle from housing as outlined in para-

graph 135 and hydraulic ram (cylinder) from axle housing. Then, unbolt and remove rear axle housing from transmission housing.

Renew "O" ring (20—Fig. AC111) and tighten retaining cap screws to a torque of 130-140 Ft.-Lbs. when re-installing axle housing. Reinstall rear axle as outlined in paragraph 135.

BRAKES

Bendix Band/Disc brakes are used. Refer to Fig. AC116.

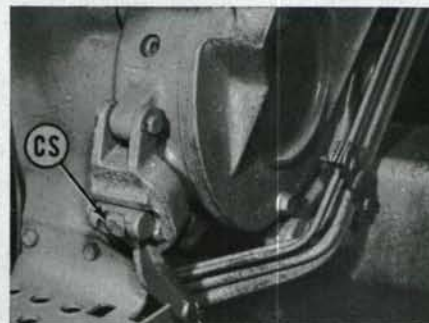

Fig. AC115 — Adjust cap screw (CS) so that brake pedals apply equally and have approximately two inches of free travel. Cap screws are self-locking.

137. ADJUSTMENT. To adjust either brake, turn cap screws (CS—Fig. AC115) in or out so that brake pedal has 2 inches of free travel. Cap screw at each brake assembly is self-locking. Be sure that brakes are adjusted so that both pedals are aligned when brakes are applied.

138. R&R AND OVERHAUL. To remove brake assemblies, first unbolt and remove rear fenders from brake housing covers (1—Fig. AC116). Unbolt and remove brake housing cover. Drum and disc unit (Fig. AC117) can then be removed from bull pinion shaft. To remove contracting band,

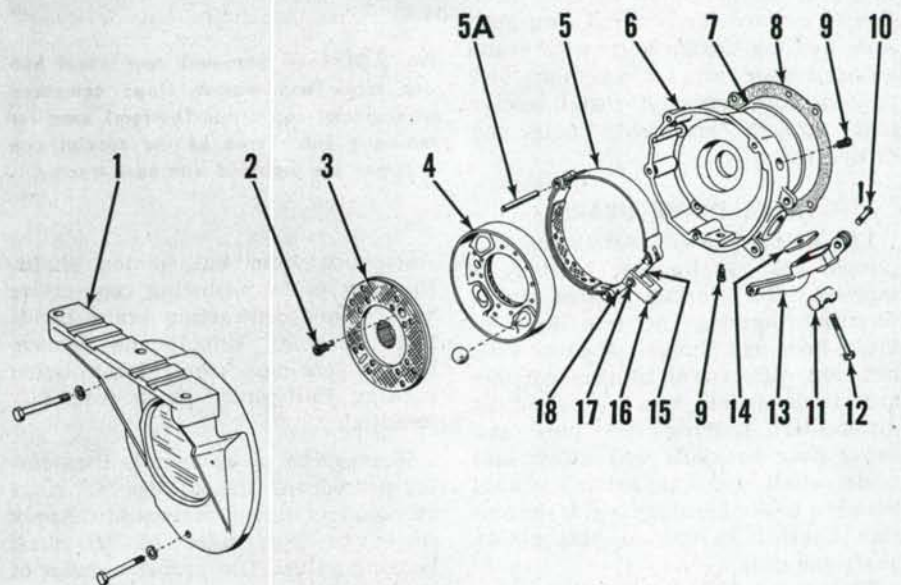

Fig. AC116 — Exploded view of D-19 brake assembly.

- | | | | |
|------------------------|--------------------|---------------------|------------------|
| 1. Brake housing cover | 5. Band assembly | 9. Springs | 14. Seal |
| 2. Spring | 5A. Band pivot pin | 10. Pin | 15. Link (outer) |
| 3. Disc assembly | 6. Brake housing | 11. Bar | 16. Yoke |
| 4. Drum assembly | 7. "O" ring | 12. Adjusting screw | 17. Pin |
| | 8. Shims | 13. Lever | 18. Link (inner) |

CLICK HERE TO **DOWNLOAD** THE COMPLETE MANUAL

- Thank you very much for reading the preview of the manual.
- You can download the complete manual from: www.heydownloads.com by clicking the link below



- Please note: If there is no response to CLICKING the link, please download this PDF first and then click on it.

CLICK HERE TO **DOWNLOAD** THE COMPLETE MANUAL