



SERVICE

ADVANCE®

**Hydro-Retriever
5000 G/P
Service Manual**

Form Number 043005 1/89
This Manual Is For Machines After Serial Number 254601

CLICK HERE TO **DOWNLOAD** THE COMPLETE MANUAL

- Thank you very much for reading the preview of the manual.
- You can download the complete manual from: www.heydownloads.com by clicking the link below



- Please note: If there is no response to CLICKING the link, please download this PDF first and then click on it.

CLICK HERE TO **DOWNLOAD** THE COMPLETE MANUAL

BRUSH DRIVE BELT REPLACEMENT (CONT'D)

- * Start the engine, lower the brush drive assembly to the floor and turn the engine off.

NOTE

Do not start the brush drive motor with the belt loose.

- * Remove the 3 "D" bolts and thread 2 of them into the holes marked "E". The bolts now work as a puller. Tighten the bolts to split the pulley.
- * Loosen the 3 "G" set screws and remove the 3 "H" bolts.
- * Work the belt between the coupler casting and the flexible coupler to remove it from the machine.
- * Follow the above instructions in reverse order to install the new belt.
- * Put the belt around the pulleys and turn the adjusting bolt (B) to raise the motor mounting plate (tightening belt tension). When properly adjusted, the belt should move about 1/4 inch (6 mm) when moderate pressure is applied between the 2 pulleys.
- * Tighten the lock bolts (B).

GEAR CASE COUPLER REMOVAL

- * Loosen the 6 "G" set screws (see Figure 1) and remove the 6 "F" bolts.

BRUSH LIFT CYLINDER REMOVAL

- * With scrub brushes on the machine, put the brushes in the down position.
- * Open the front panel and disconnect the parking brake lever arms by removing the cotter pin and sliding the pin out.
- * Remove the 4 bolts that hold the parking brake lever in place and remove the lever.
- * Remove the brake pedal pad by removing the the 2 screws under the decal, in the center of the pad.
- * Remove the screws from the left front corner panel of the operator's compartment. Work the panel away from the brake pedal and lift it out of the machine.

OUTER SIDE SKIRT ADJUSTMENT (CONT'D)

- * Turn the steering wheel all the way to the left. This should raise the right skirt and lower the left skirt.
- * Adjust the up position on the right skirt. Loosen the 4 "J" screws (see Figure 6) and adjust the skirt lifting cables so that the bottom edge of the skirt is 3/8 inch (10 mm) off of the floor.

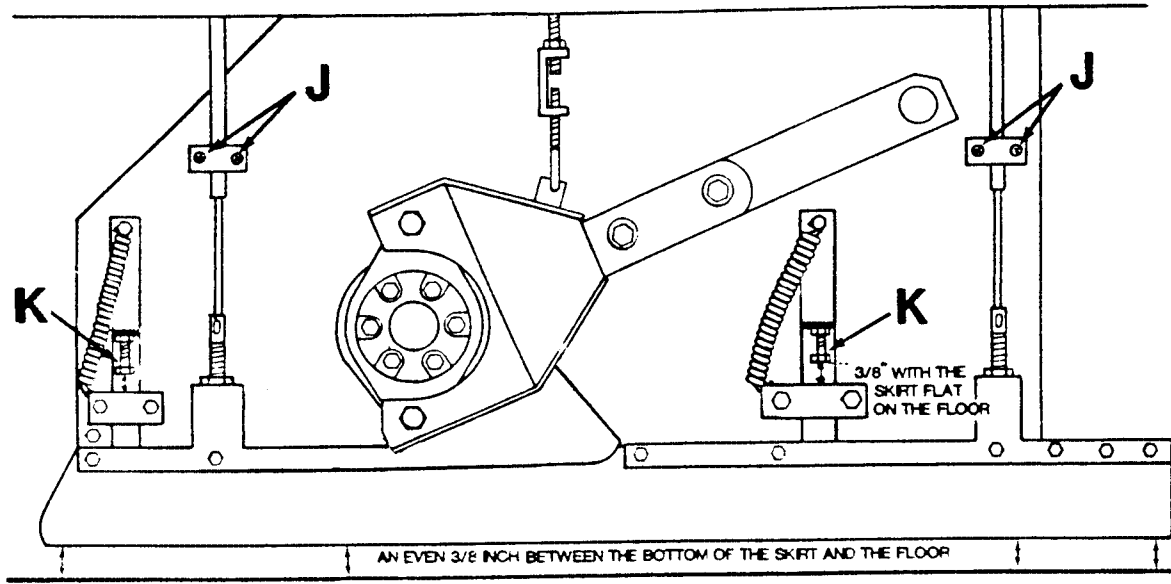

FIGURE 7

- * Adjust the down position of the left skirt. Loosen the locknuts and turn the 2 "K" bolts so that there is 3/8 inch (10 mm) between the head of the bolt and the down stop plates.

SWEEPING SYSTEM TROUBLESHOOTING

PROBLEM:

BROOM MOTOR RUNS BUT DEBRIS IS LEFT ON FLOOR

POSSIBLE CAUSES:

HOPPER FULL

BROOM NEEDS ADJUSTMENT

TOO MUCH SOLUTION BEING DISPENSED

FRONT SKIRT DAMAGED OR MISSING

SQUEEGEE LIFT SYSTEM WIRING DIAGRAM

The diagram below shows the flow of electricity through the squeegee lift system, in the simplest possible way.

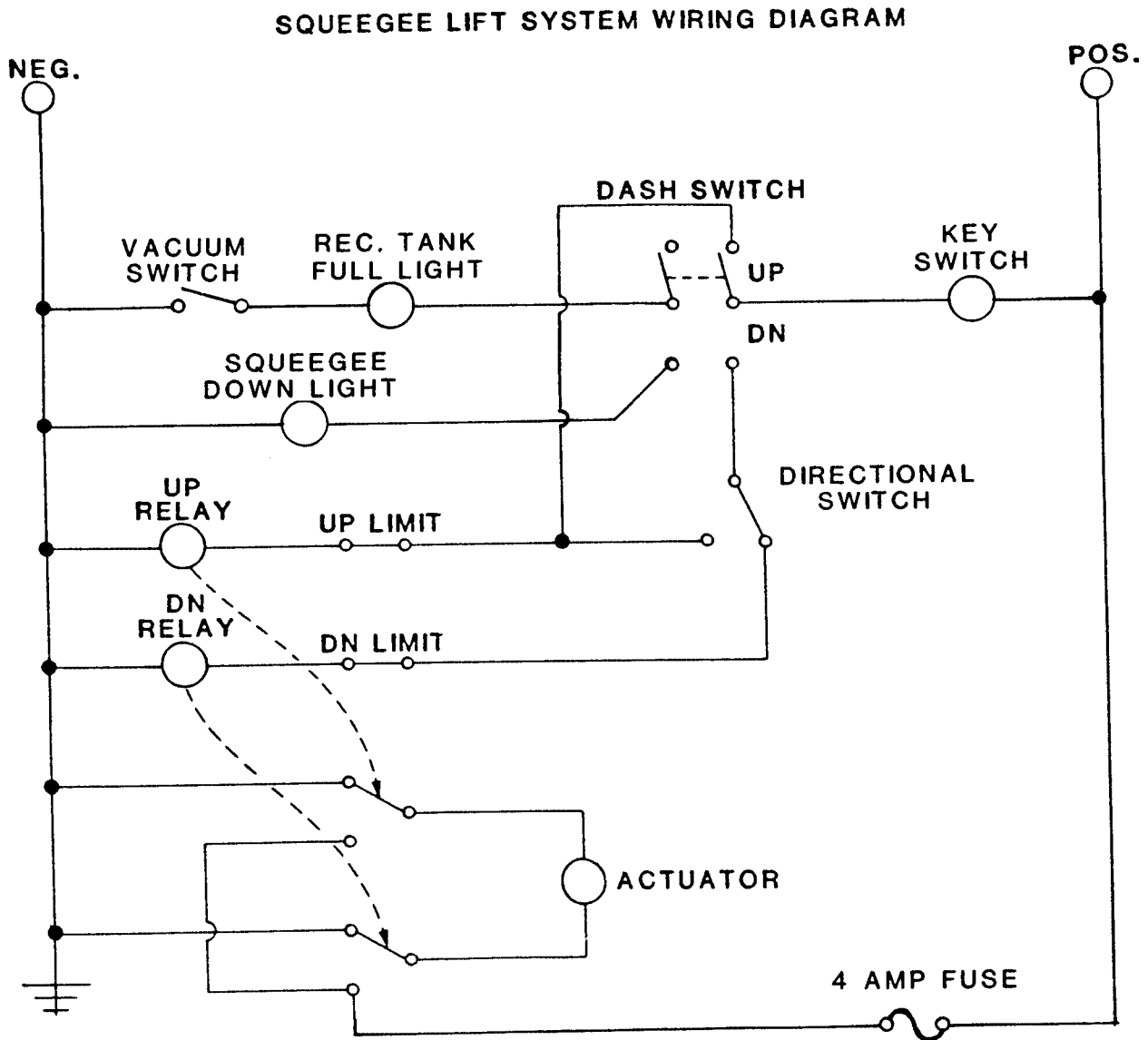

SQUEEGEE ADJUSTMENTS

Before adjusting the squeegee, remove the tool from the machine and inspect the squeegee blades. Replace them if they are cut, nicked, wavy or if the front edge of the wiping blade is worn to a large radius.

To adjust the squeegee...

- * Turn the key switch on and put the squeegee lift switch (on the dashboard) in the down position.

HYDRAULIC SYSTEM

CLICK HERE TO **DOWNLOAD** THE COMPLETE MANUAL

- Thank you very much for reading the preview of the manual.
- You can download the complete manual from: www.heydownloads.com by clicking the link below



- Please note: If there is no response to CLICKING the link, please download this PDF first and then click on it.

CLICK HERE TO **DOWNLOAD** THE COMPLETE MANUAL