

2017

SERVICE MANUAL



PROWLER®
700 XT™ / 1000 XT™

CLICK HERE TO **DOWNLOAD** THE COMPLETE MANUAL

- Thank you very much for reading the preview of the manual.
- You can download the complete manual from: www.heydownloads.com by clicking the link below



- Please note: If there is no response to CLICKING the link, please download this PDF first and then click on it.

CLICK HERE TO **DOWNLOAD** THE COMPLETE MANUAL

A new spark plug should be tightened 1/2 turn once the washer contacts the cylinder head. A used spark plug should be tightened 1/8-1/4 turn once the washer contacts the cylinder head.

Muffler/Spark Arrester

Clean the spark arrester using the following procedure.

⚠ WARNING

Wait until the muffler cools to avoid burns.

1. Remove the cap screws securing the spark arrester assembly to the muffler; then loosen and remove the spark arrester. Account for a gasket.



PR879

2. Using a suitable brush, clean the carbon deposits from the screen taking care not to damage the screen.

■NOTE: If the screen or gasket is damaged in any way, it must be replaced.

3. Install the spark arrester assembly and gasket and secure with the cap screws. Tighten the cap screws to 50 in.-lb.

Engine/Transmission Oil - Filter

■NOTE: The engine should always be warm when the oil is changed so the oil will drain easily and completely.

1. Park the vehicle on level ground.
2. On the 700, remove both seats and the center console. On the 1000, remove the driver's seat and seat base.
3. Remove the oil level stick/filler plug.

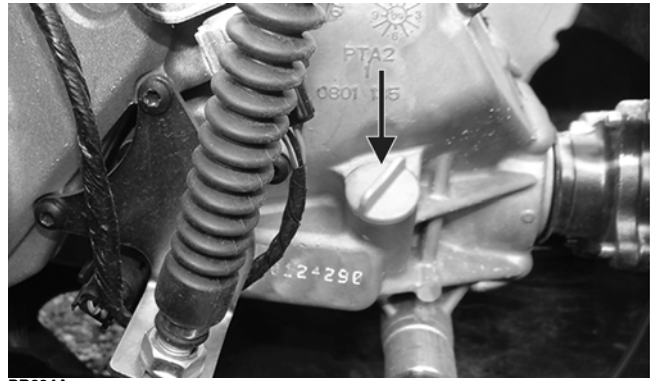

PR824A

⚠ WARNING

Use extreme caution when removing the oil drain plug. Hot oil can cause severe injury and skin burns.

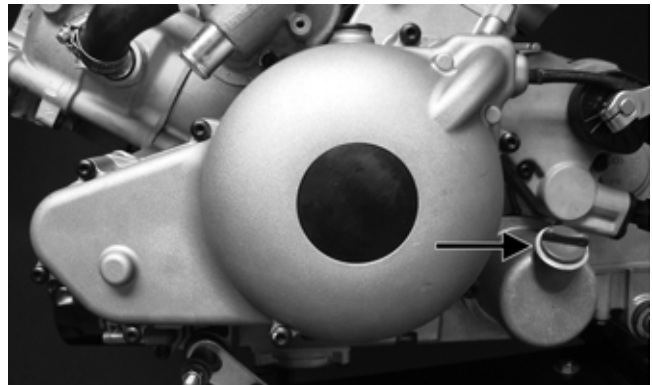

GZ415A

4. Remove the drain plug from the bottom of the engine and drain the oil into a drain pan. Thoroughly clean the drain plug. Discard the drain plug gasket.

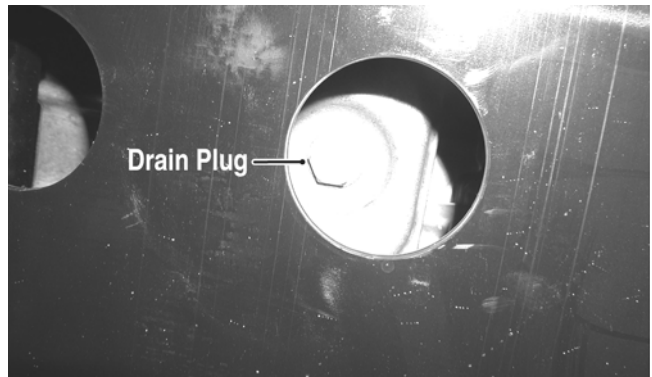

PR078A

5. Using the Oil Filter Wrench and a ratchet handle (or a socket or box-end wrench), remove the old oil filter.

■NOTE: Clean up any excess oil after removing the filter.

6. Apply new engine oil to the new oil filter O-ring and check to make sure it is positioned correctly; then install the new oil filter. Tighten securely.

Steering System

REMOVING STEERING SHAFT/EPS ASSEMBLY

■NOTE: Thoroughly troubleshoot the EPS system (if equipped) prior to replacing the EPS assembly (see Electrical System - Electronic Power Steering (EPS)) as there are several possible external causes for system failure.

1. Remove the hood, front access panel, and front fenders; then disconnect the regulator/rectifier and remove the screws securing the coolant bottle to the front storage box.
2. Remove the front storage box; then remove the steering wheel.
3. Disconnect the tilt steering mechanism from the steering shaft; then remove the shift lever knob.
4. Disconnect the wiring harness connectors from the back of the dash; then remove the dash.
5. Remove the two cap screws securing the steering shaft housing to the frame.

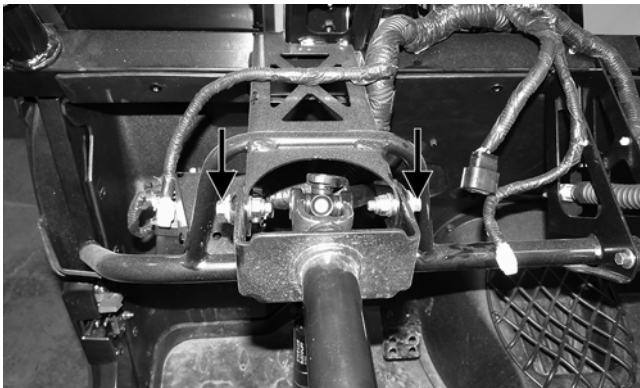

PR897A

■NOTE: Steps 6 and 7 are for non-EPS models. For EPS models, complete steps 8-11.

6. Make matching alignment marks on the pinion shaft and steering shaft joint.

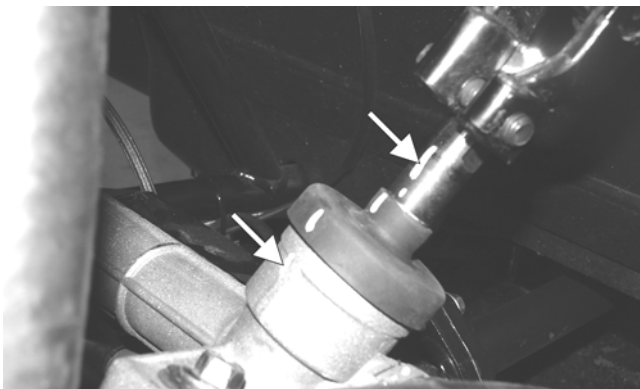

PR333A

7. Remove the cap screw and lock nut securing the lower steering shaft joint to the pinion shaft; then slide the joint free of the pinion. Discard the lock nut.

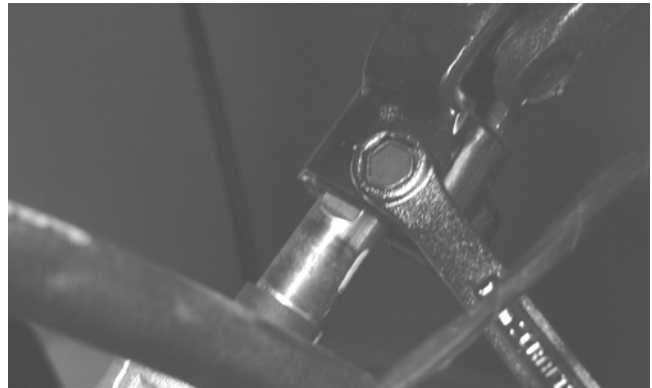

PR302

8. Make matching alignment marks; then disconnect the cap screw and lock nut securing the steering shaft to the EPS assembly. Discard the lock nut.



PR917

9. Disconnect the two EPS connectors.
10. Remove the cap screws securing the EPS assembly to the frame; then remove the cap screw securing the rack coupler to the EPS output shaft.

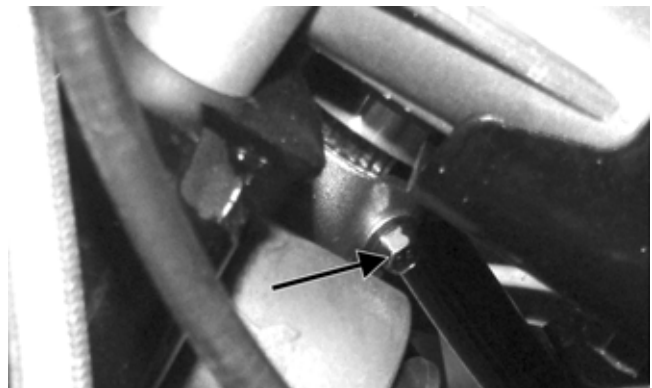

PR761A

■NOTE: The EPS assembly is not a serviceable component and must be replaced as a complete assembly.

11. Remove the EPS from the top side.

INSTALLING STEERING SHAFT/EPS ASSEMBLY

1. Install the EPS into position.
2. Align the slot in the rack coupler to the notch in the frame (front wheels centered).

3. Inspect the welds of the cargo box frame for cracking or bending.
4. Inspect the cargo box gate latches for smooth operation.

INSTALLING

1. With the help of an assistant or an adequate lift, set the cargo box into position on the frame; then position the two upper pivot housings between the cargo box and frame. Lightly grease the pivot housings.
2. Align the holes in the upper pivot housings with the holes in the cargo box; then install the lower pivot housings and secure with the four shoulder cap screws. Tighten to 20 ft-lb.
3. Raise the cargo box; then connect the lift support to the frame, install the screw and nut, and tighten the nut securely.
4. Lower the cargo box and lock into position.

Taillight Assembly

REMOVING

1. Remove two torx-head screws and lock nuts securing the taillight assembly to the rear ROPS bracket; then rotate the taillight assembly left or right to allow the connector to clear the access opening.

2. Disconnect the three-prong connector from the bulb socket and remove the taillight assembly.

INSPECTING

1. Inspect wiring harness, three-prong connector, lens, base, cap screws, and socket for damage.
2. Inspect all wires for corroding, pinching, and cracking.
3. Inspect the bulb for wattage, voltage, and proper operation.

INSTALLING

1. Connect the three-prong connector to the bulb socket; then place the taillight assembly into position on the rear ROPS bracket.
2. Install the two torx-head screws and new lock nuts and tighten securely.

Seats

REMOVING/INSTALLING

1. To remove a seat, pull the seat lock lever up. Raise the front of the seat and slide it forward.
2. To install a seat, slide the rear of the seat into the seat retainers and push down firmly on the front of seat. The seat should automatically lock into position.

Troubleshooting

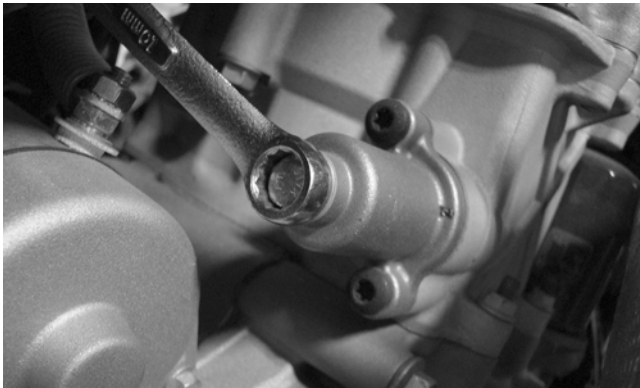

H1-055

6. Using an awl, rotate the C-ring in its groove until it is out of the cylinder head; then remove the C-ring.

NOTE: Care should be taken not to drop the C-ring down into the crankcase.

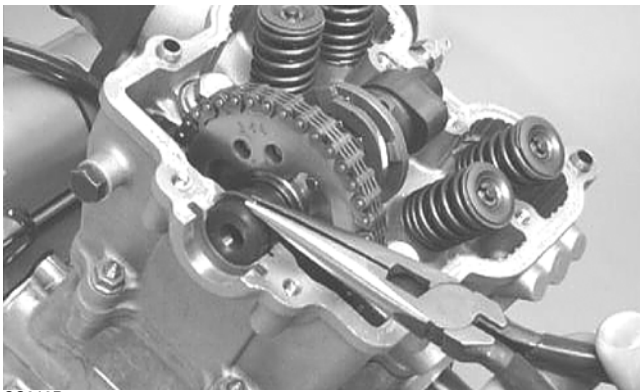

CC012D

7. Bend the washer tabs down and remove the two cap screws securing the sprocket to the camshaft; then drop the sprocket off the camshaft.

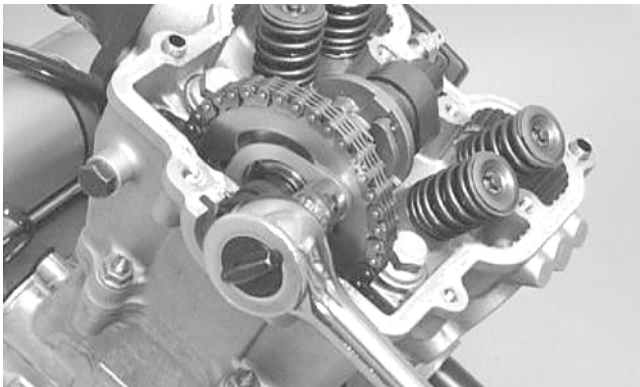

CC013D

8. While holding the chain, slide the sprocket and camshaft out of the cylinder head.

NOTE: Loop the chain over the cylinder and secure it to keep it from falling into the crankcase.

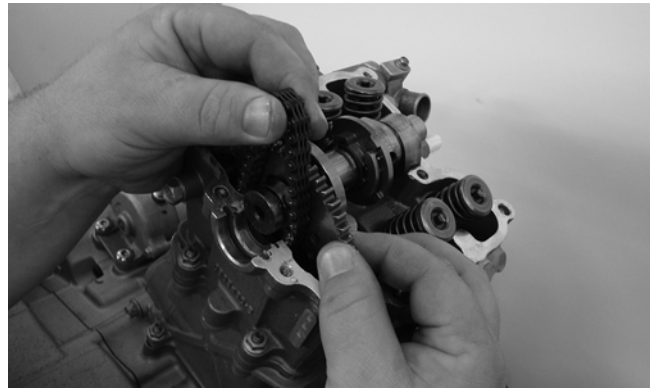

H1-036

9. Remove the cap screw securing the chain tensioner (account for a washer); then remove the tensioner.



H1-037

10. Remove the five nuts securing the cylinder head to the cylinder.

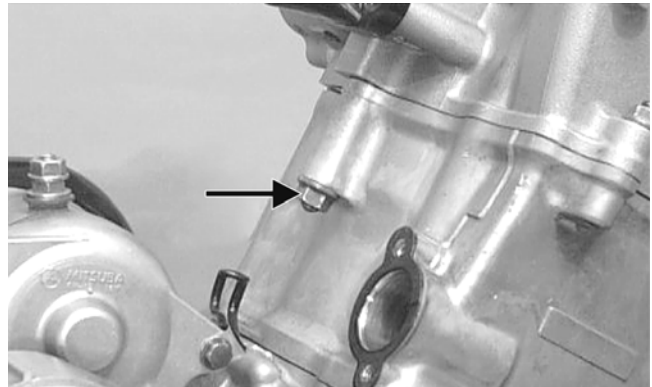

CC017D

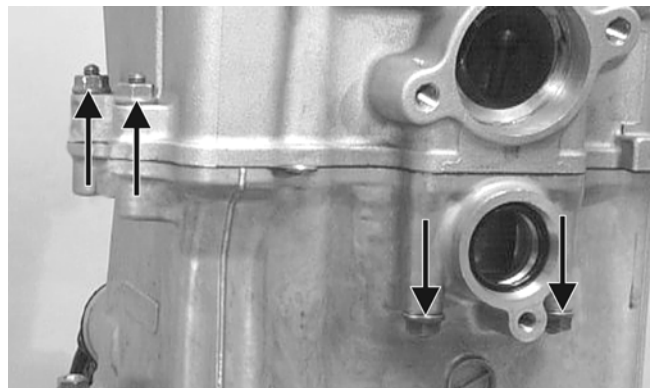

CC018D

11. Remove the four cylinder head bolts.

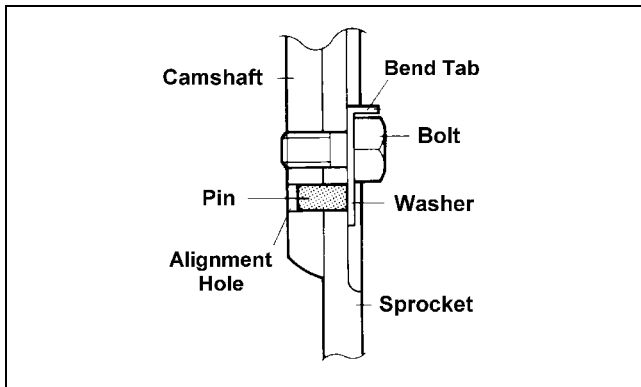

ATV1027

CAUTION

Care must be taken that the tab-washer is installed correctly to cover the alignment hole on the sprocket. If the alignment pin falls out, severe engine damage will result.

18. Install the first cap screw (threads coated with red Loctite #271) securing the sprocket and tab-washer to the camshaft. Tighten only until snug.

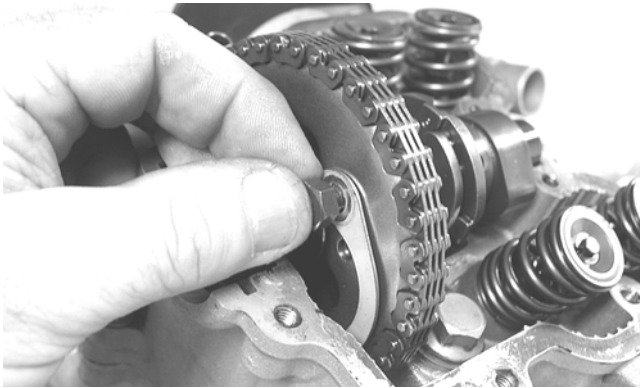

CD464

19. Rotate the crankshaft until the second cap screw securing the sprocket to the camshaft can be installed; then install the cap screw (threads coated with red Loctite #271) and tighten to 10 ft-lb. Bend the tab to secure the cap screw.

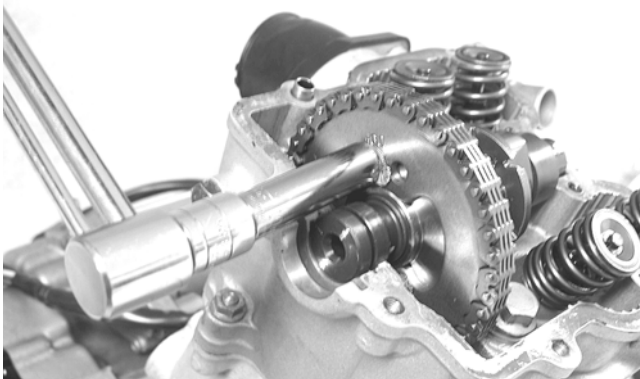

CD465

20. Rotate the crankshaft until the first cap screw (from step 18) can be accessed; then tighten to 10 ft-lb. Bend the tab to secure the cap screw.

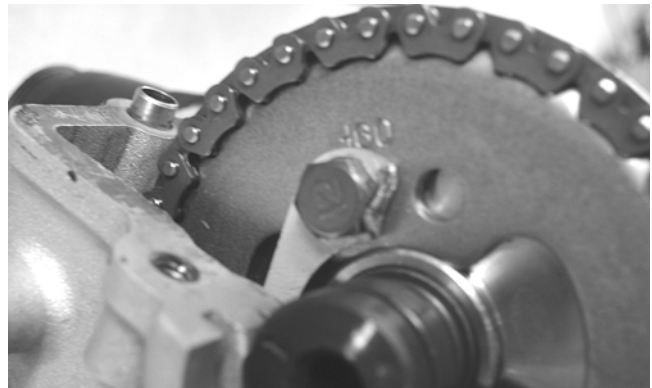

CD466

21. Place the C-ring into position in its groove in the cylinder head.

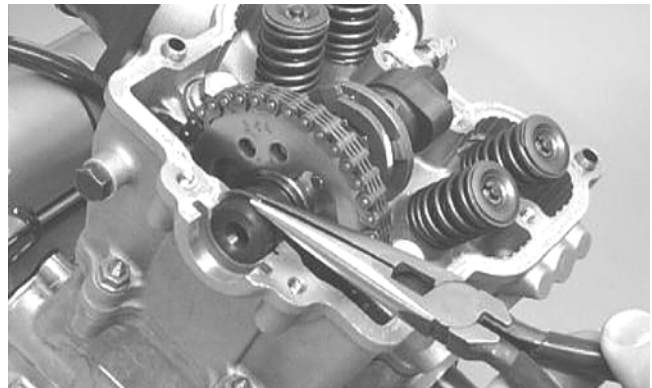

CC012D

22. Install the cylinder head plug in the cylinder head with the open end facing downward and toward the inside.

CAUTION

The open end of the plug must be positioned downward.

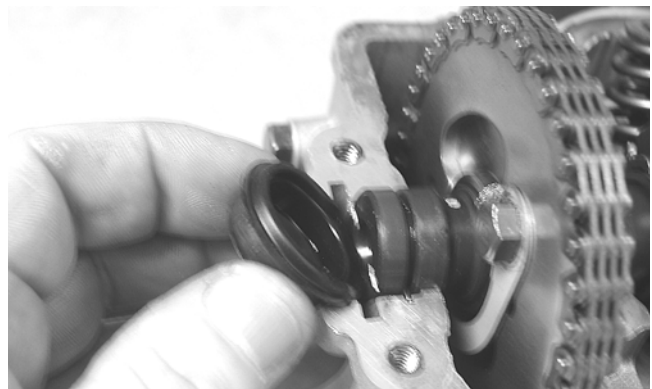

CD468

23. Remove the cap screw from the end of the chain tensioner; then using a flat-blade screwdriver, rotate the adjuster screw inside the tensioner clockwise until the screw bottoms and the adjuster shaft is held in place.

- Remove the V-belt.
- Remove the nut securing the fixed driven assembly; then remove the assembly.

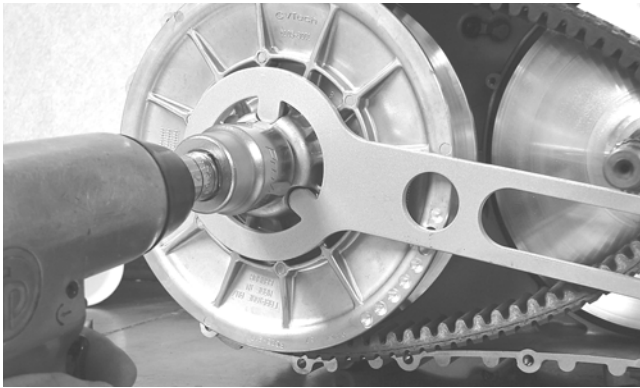

PR388

- Remove the fixed drive face.
- Remove the cap screws securing the clutch cover. Note the location of the different-lengthed cap screws (A and B) for installing purposes. Using a rubber mallet, carefully remove the cover. Account for two alignment pins.

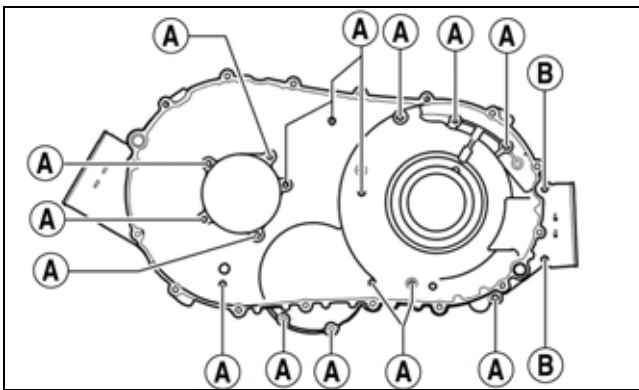

H1-058A

CAUTION

Care must be taken when removing the cover so the cover gasket is not damaged.

■NOTE: For steps 7-13, refer to illustration H1-029A below.

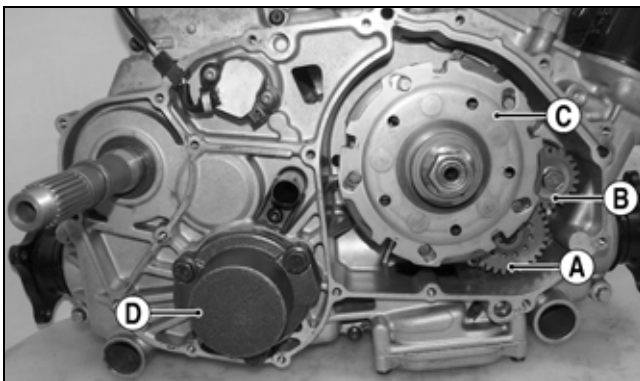

KEY

- | | |
|-------------------------|--|
| A. Oil Pump Driven Gear | D. Final Drive Carrier Bearing Housing |
| B. Oil Pump Drive Gear | |
| C. Clutch Shoe Assembly | |

H1-029A

■NOTE: To aid in installing, it is recommended that the assemblies are kept together and IN ORDER.

- Using a hydraulic press, remove the clutch housing assembly from the clutch cover. Account for the left fixed drive spacer and an O-ring inside the fixed drive spacer.



CF085



CC596

■NOTE: Account for and inspect the clutch housing seal.

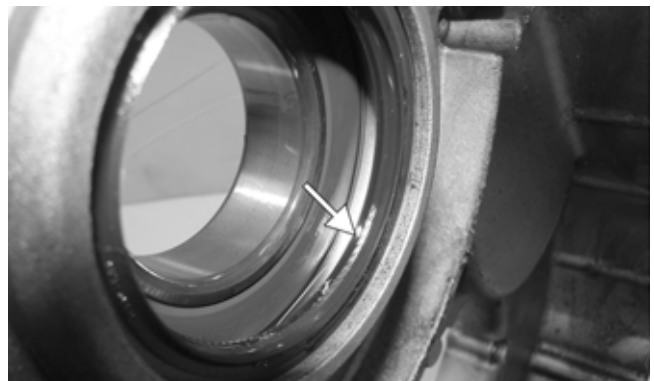

H1-034A

■NOTE: Perform steps 8 and 9 only if the associated components are in need of servicing.

- Remove the cap screws securing the two bearing retainers. Retain the retainers and the cap screws. Using a press, press the existing bearing out of the clutch cover.

Disassembling Crankcase Half

■NOTE: For steps 1-7, refer to illustration PR787A.

■NOTE: To aid in installing, it is recommended that the assemblies are kept together and IN ORDER.

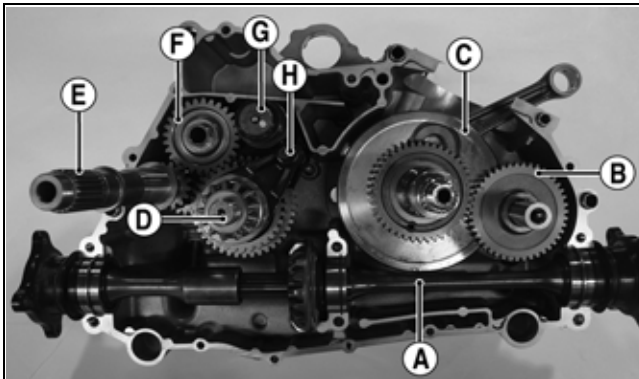

KEY

- | | |
|------------------------------------|--------------------------------|
| A. Secondary Driven Shaft Assembly | E. Driveshaft |
| B. Crank Balancer Assembly | F. Reverse Idler Gear Assembly |
| C. Crankshaft | G. Gear Shift Shaft |
| D. Countershaft Assembly | H. Shift Shaft with 2 Forks |

PR787A

1. Remove the secondary driven shaft assembly (A) noting the location of the bearing locating pins. Account for the bearing C-ring.

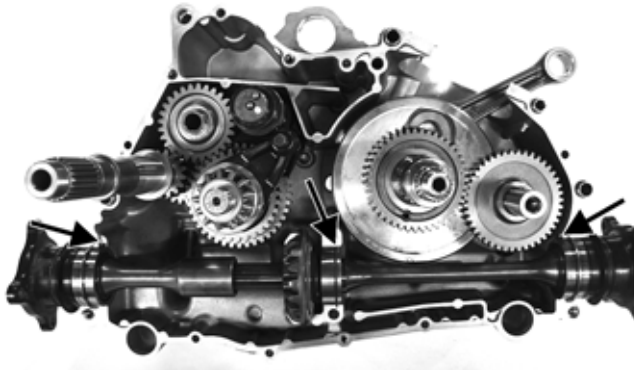

PR787B

2. Remove the reverse idler gear assembly (F). Account for all washers, shaft, bushing, and the gear.

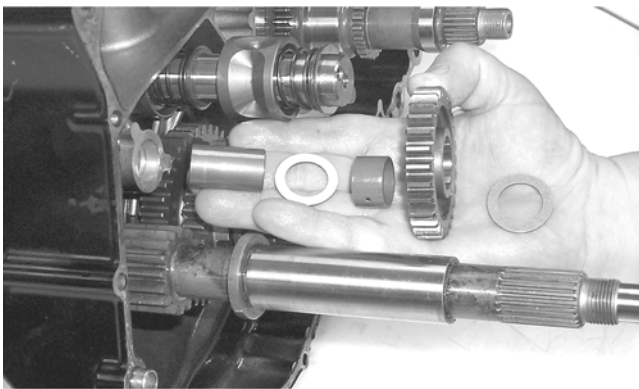

CC668

3. Remove the shift shaft (H); then remove the two forks taking note of the direction of the tabs on the forks for assembling purposes.
4. Remove the gear shift shaft (G) noting the location of the two holes on the end of the shaft. Account for a spacer and a washer.



DE677A

5. Remove the countershaft assembly (D). Account for a washer on each end of the countershaft.

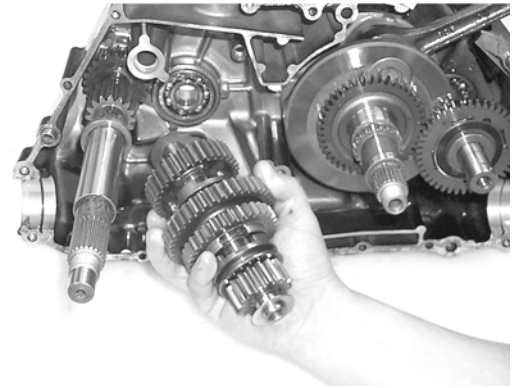

CC674

■NOTE: Do not disassemble the countershaft assembly unless necessary. If necessary, see Servicing Center Crankcase Components sub-section.

6. Using a rubber mallet, tap on the crankcase to remove the driveshaft.

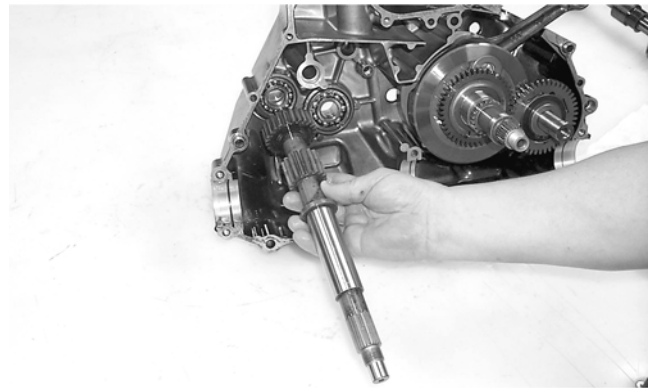

CC675

7. Note the timing marks on the crank balancer assembly (B) gear and crankshaft (C) gear for assembling purposes; then slide the crank balancer gear off the crank balancer. Account for the key in the keyway.

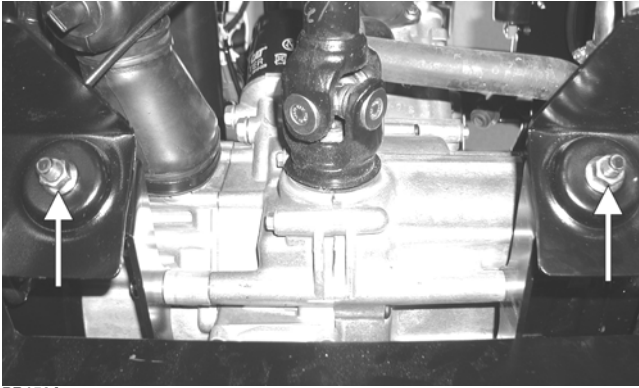

PR153A

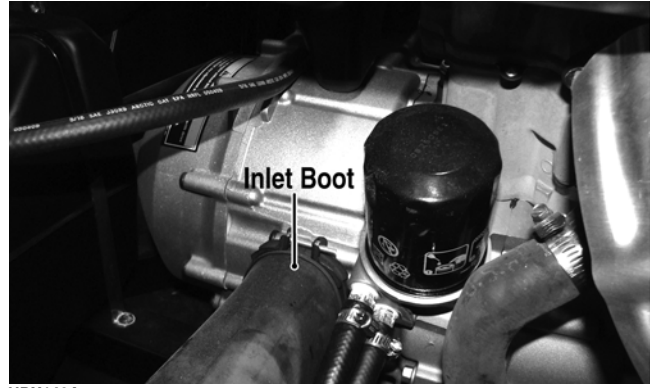

HDX140A

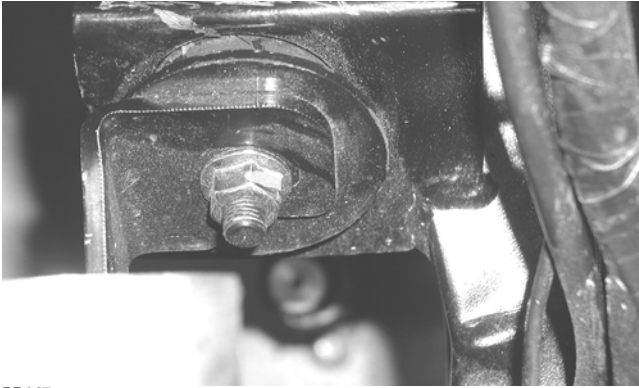

PR147

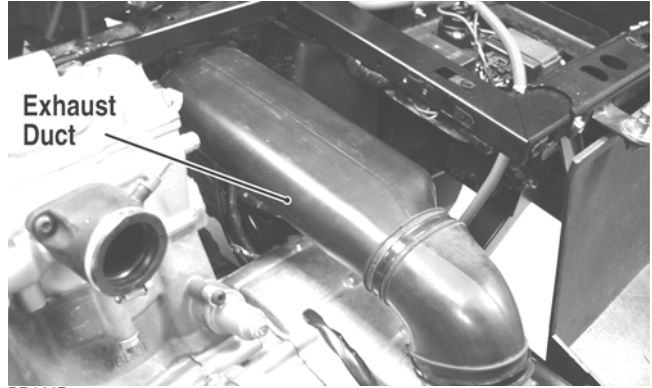

PR144B

4. Install the cap screws securing the front and rear drive couplers to the drive flanges and tighten to 20 ft-lb.

7. Connect the lower coolant hose to the water pump housing; then connect the upper coolant hose to the thermostat housing. Tighten the hose clamps securely.

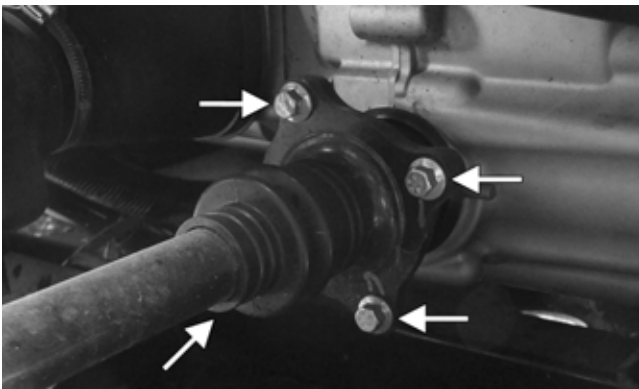

PR969A



PR838

5. Set the exhaust pipe in place; then install the muffler and align the assembly to the engine. Install two cap screws securing the exhaust pipe to the cylinder head and tighten to 20 ft-lb. Install the muffler.

8. Install the starter wire on the starter and tighten the nut securely; then connect the magneto and crankshaft position sensor connectors. Install the engine ground wire and tighten to 8 ft-lb.

6. Install the inlet boot on the V-belt housing; then install the exhaust duct connecting the outlet housing to the V-belt housing. Tighten all clamps securely.

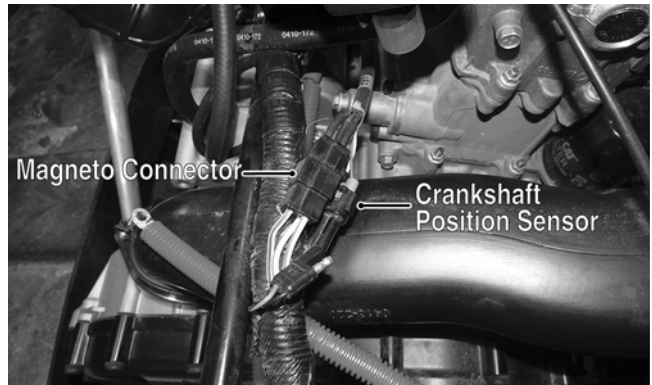

PR925A

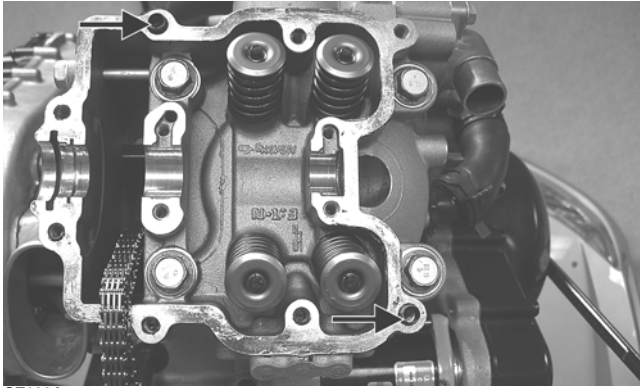

GZ132A

6. Remove the cap screw on the end of the tensioner; then using a flat-blade screwdriver, turn the tensioner clockwise to remove the tension. Remove the two cap screws securing the tensioner adjuster assembly and remove the assembly. Account for a gasket.

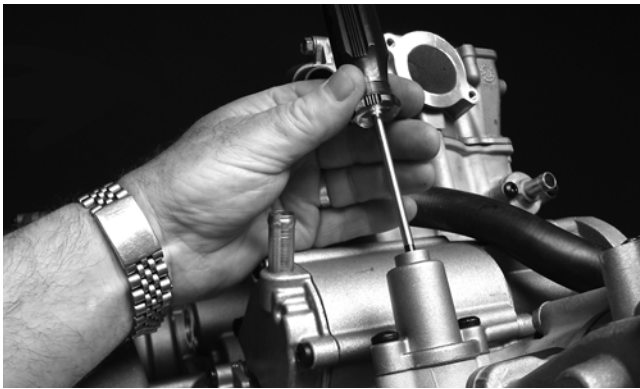

GZ405

7. Using an awl, rotate the C-ring in its groove until it is out of the cylinder head; then remove the C-ring.

■NOTE: Care should be taken not to drop the C-ring into the crankcase.

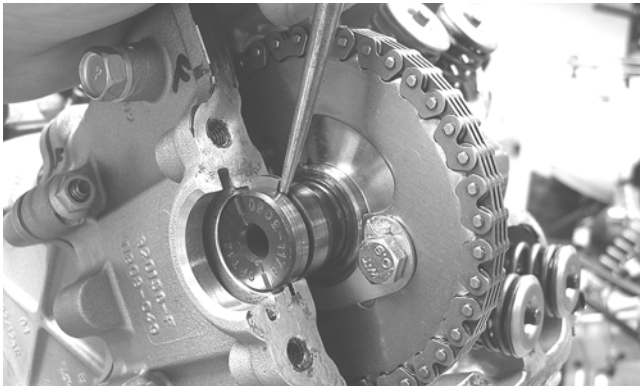

GZ155

8. Bend the washer tabs down and remove the two cap screws securing the sprocket to the camshaft; then drop the sprocket off the camshaft being careful not to drop the locating pin into the engine.

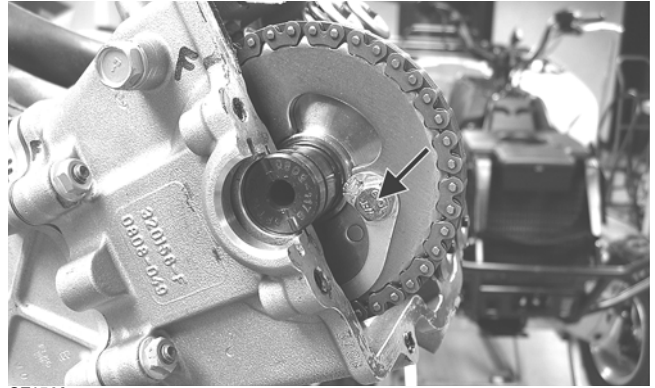

GZ154A

9. While holding the chain, slide the sprocket and camshaft out of the cylinder head.

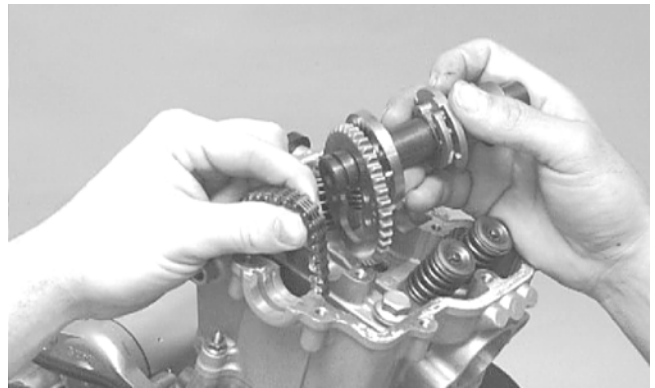

CC266D

■NOTE: Loop the chain over the cylinder head and secure it to keep it from falling into the crankcase.

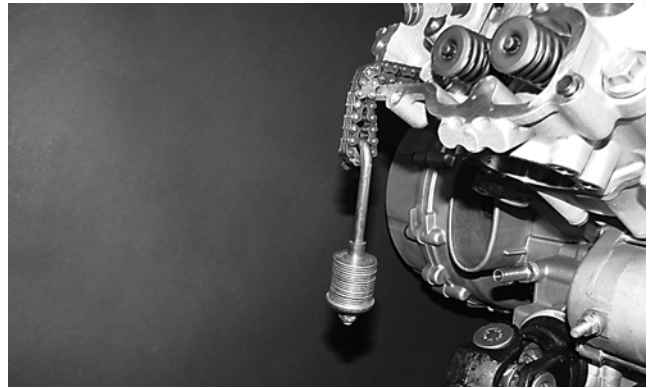

GZ408

10. Remove the five nuts securing the cylinder head to the cylinder; then remove the four cylinder head cap screws and washers.

■NOTE: Removing the starter will simplify removal of the front cylinder base nuts.

CLICK HERE TO **DOWNLOAD** THE COMPLETE MANUAL

- Thank you very much for reading the preview of the manual.
- You can download the complete manual from: www.heydownloads.com by clicking the link below



- Please note: If there is no response to CLICKING the link, please download this PDF first and then click on it.

CLICK HERE TO **DOWNLOAD** THE COMPLETE MANUAL

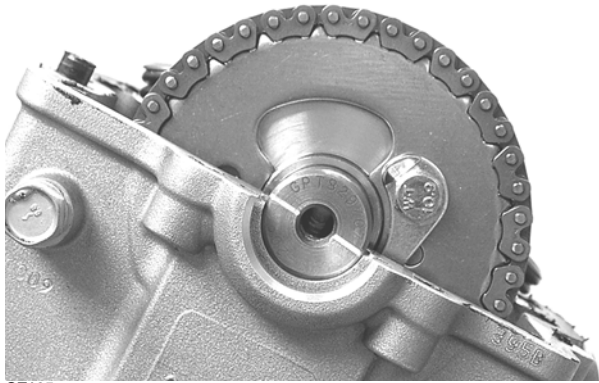

GZ195

17. Keeping tension on the opposite cam chain, rotate the crankshaft until the second cap screw securing the sprocket to the camshaft can be installed; then install the cap screw (threads coated with red Loctite #271) and tighten to 10 ft-lb. Bend the tab to secure the cap screw.

CAUTION

Failure to keep tension on any loose cam chain may cause severe engine damage.

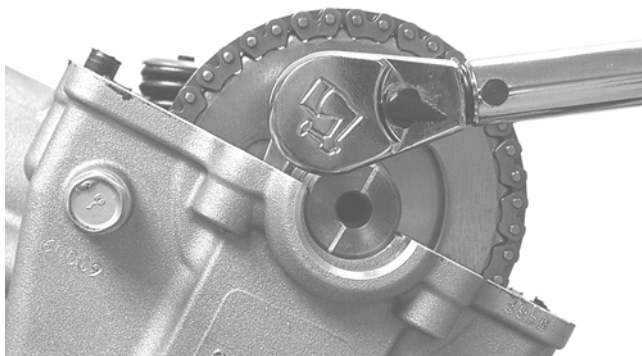

GZ193

18. Rotate the crankshaft until the first cap screw (from step 16) can be tightened; then tighten to 10 ft-lb. Bend the tab to secure the cap screw.

AT THIS POINT

Return the engine to TDC on the front cylinder making sure the cam lobes are directed downward to ensure correct starting point for step 19.

19. Keeping tension on the rear cam chain, rotate the engine forward 270° until rear piston is at TDC indicated by timing mark R.



H2-050A

20. With the alignment pin installed in the rear camshaft, loosely place the cam sprocket (with the recessed side facing the cam shaft lobes) onto the camshaft. At this point, do not “seat” the sprocket onto the shaft.

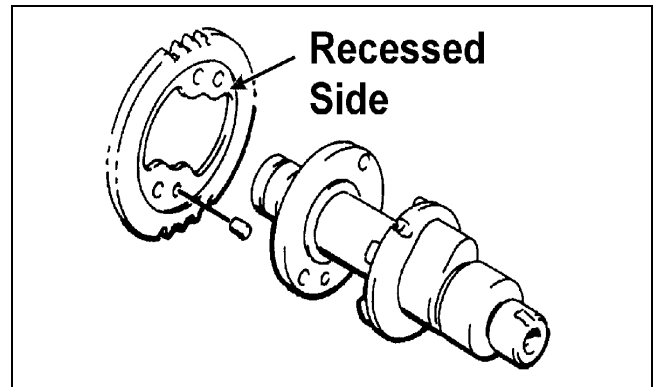

732-307B

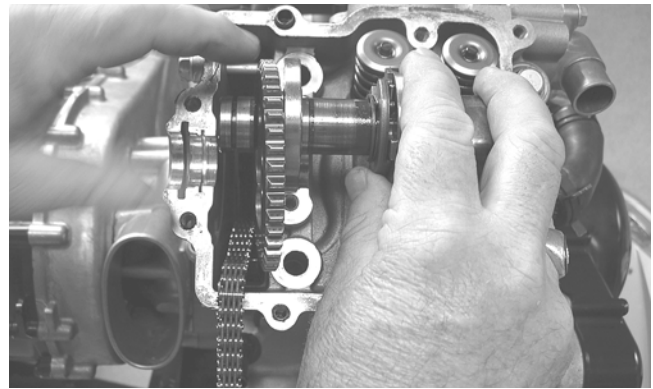

GZ130

■NOTE: At this point, oil the camshaft bearings, cam lobes, and the three seating journals on the cylinder.

21. With the cam lobes directed down (toward the piston), maneuver the camshaft/sprocket assembly through the chain and towards its seating position; then loop the chain over the sprocket.

■NOTE: Note the position of the alignment marks on the end of the camshaft. They should be parallel with the plane of the cylinder head. If rotating the camshaft is necessary for alignment, rotate the sprocket inside the chain until the alignment pin can be engaged in the sprocket with the camshaft in the nearest possible position to parallel.

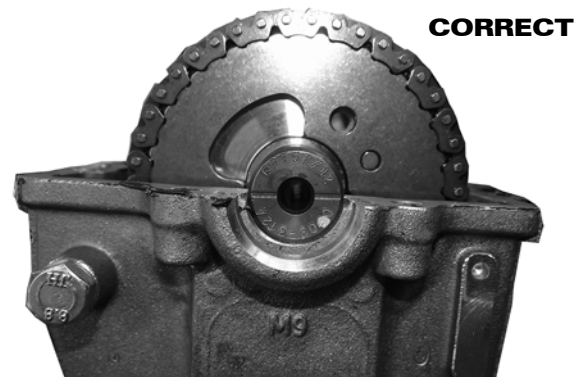

GZ519

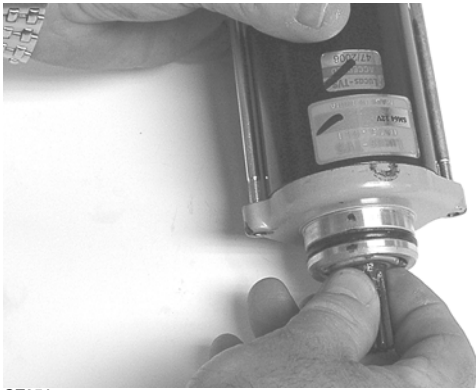

GZ251

16. Using Seal Protector Tool, install the outer magneto cover using a new gasket and secure with the cap screws. Using the pattern shown, tighten to 8.5 ft-lb.

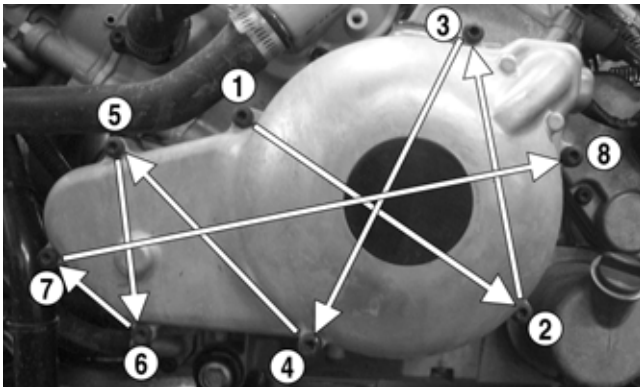

H2-051A

Right-Side Components

■NOTE: For efficiency, it is preferable to remove and disassemble only those components which need to be addressed and to service only those components. The technician should use discretion and sound judgment.

AT THIS POINT

To service any one specific component, only limited disassembly of components may be necessary. Note the AT THIS POINT information in each sub-section.

■NOTE: The engine/transmission does not have to be removed from the frame for this procedure.

Removing Right-Side Components

- A. CVT Cover
- B. Drive Clutch
- C. Driven Clutch
- D. Centrifugal Clutch
- E. Inner Clutch Cover

1. Remove the cap screws securing the CVT cover; then using a rubber mallet, gently tap on the cover tabs to loosen the cover. Account for a gasket and two alignment pins.

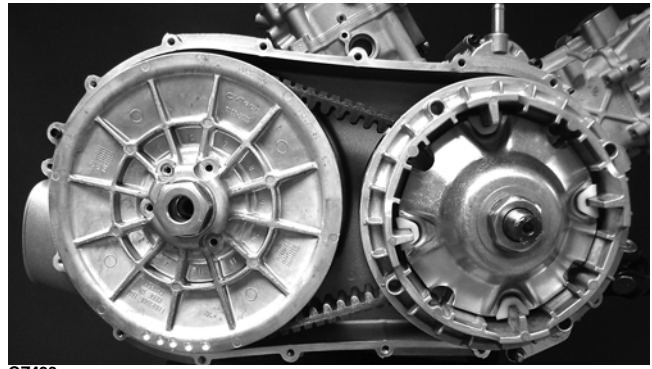

GZ428

2. Remove the nut securing the movable drive face; then remove the face. Account for a spacer and a flat washer.

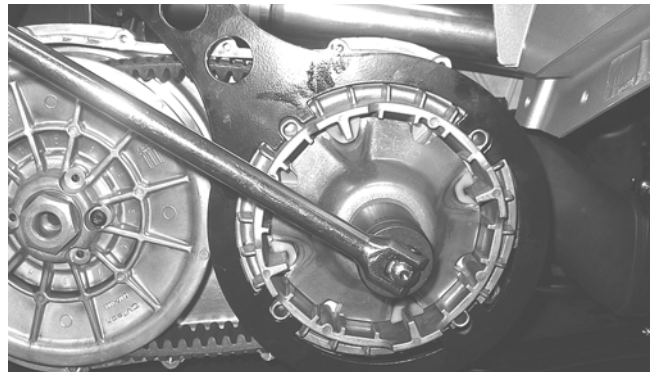

GZ074

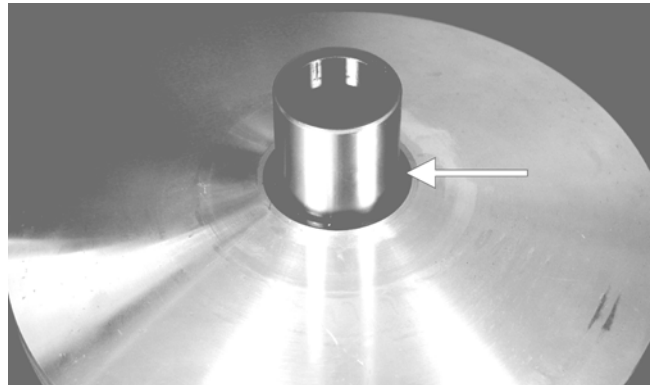

CD966A

3. Remove the V-belt.

4. Remove the nut securing the fixed driven assembly; then remove the assembly.



PR388

5. Remove the fixed drive face.

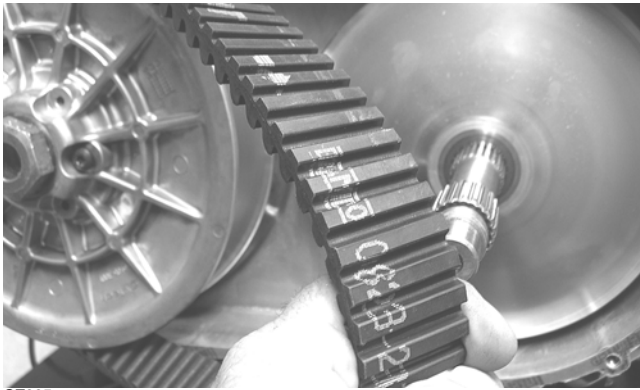

GZ085

■NOTE: The arrows on the V-belt should point forward.

CAUTION

Make sure the splines extend beyond the drive face and washer or a false torque reading and spline damage may occur.

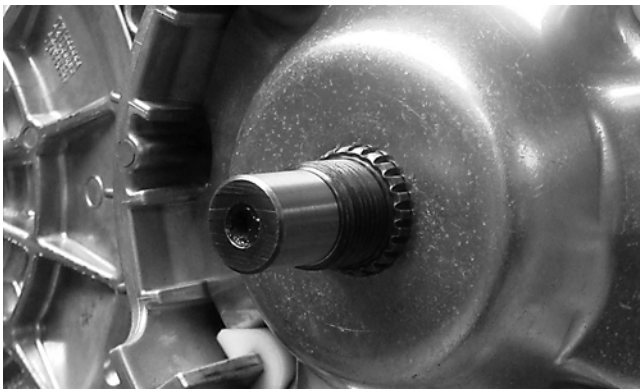

GZ485

15. Pinch the V-belt together near its center and slide the spacer and movable drive face onto the shaft. Using an appropriate spanner wrench, secure the drive face with a flat washer and a nut (threads coated with red Loctite #271). Tighten the nut to 162 ft-lb.



GZ075

■NOTE: At this point, the cap screw can be removed from between the driven clutch faces.

16. With the engine in neutral, rotate the V-belt and clutches counterclockwise until the V-belt is flush with the top of the driven clutch.

17. Place the CVT cover gasket into position; then install the cover and secure with the cap screws. Tighten the cap screws to 97 in.-lb.

Center Crankcase Components

■NOTE: This procedure cannot be done with the engine/transmission in the frame. Complete Removing procedures for Top-Side, Left-Side, and Right-Side must precede this procedure.

■NOTE: For efficiency, it is preferable to remove and disassemble only those components which need to be addressed and to service only those components. The technician should use discretion and sound judgment.

Separating Crankcase Halves

1. Remove the oil strainer cap; then remove the oil strainer.

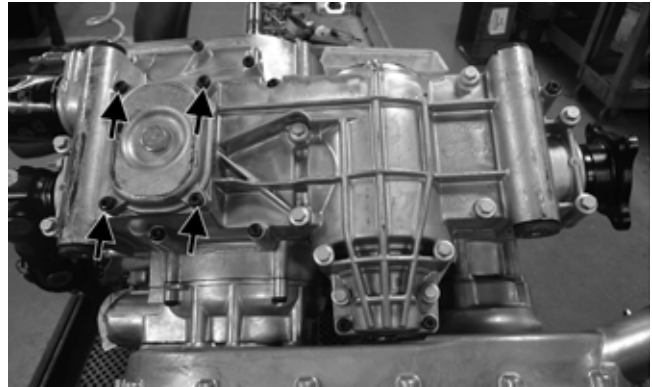

H2-012A



GZ446

2. Remove the cap screws securing the lower crankcase to the upper crankcase halves; then using a rubber hammer, free the lower crankcase and remove. Account for two alignment pins.

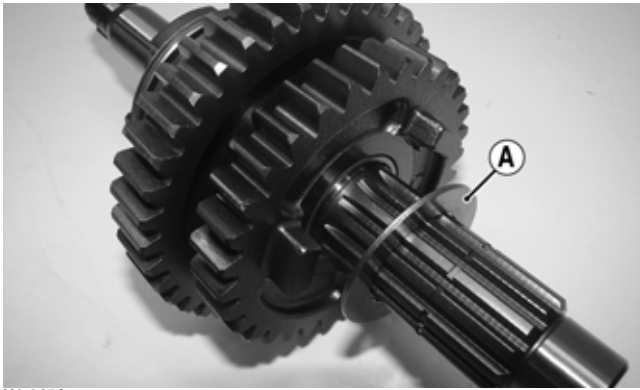

H1-045A



H1-044

4. Install the reverse driven dog (A) onto the countershaft and secure with a new snap ring (B).

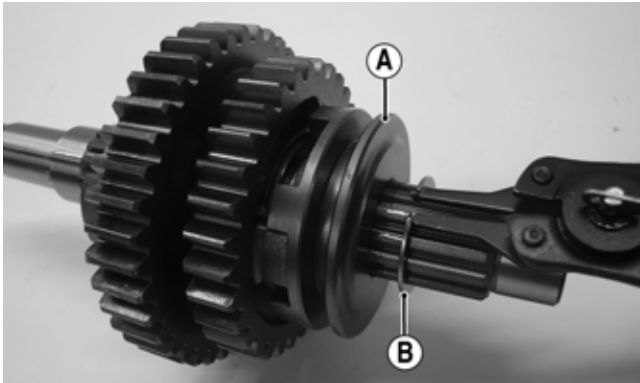

H1-043A

5. Install the drive gear.

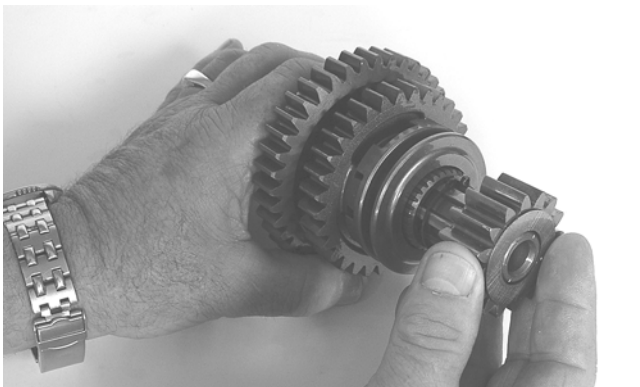

GZ296

6. From the opposite end of the countershaft, install the high/low driven gear dog (A), thrust washer (B), bearing (C), high driven gear (D), and spacer washer (E).

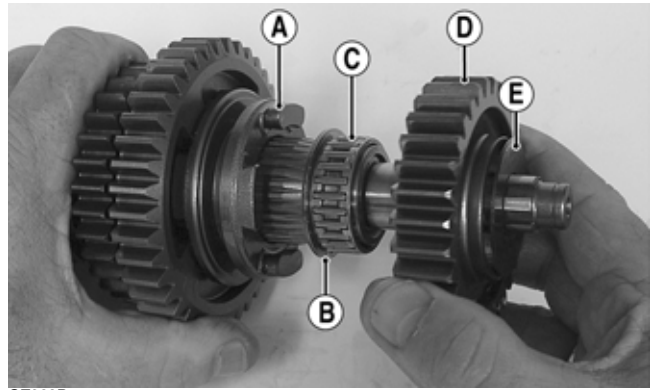

GZ283D

7. Install the drive gear washer and the shift forks. The countershaft is now ready for installation.

■NOTE: When installing the countershaft assembly, account for the washer on each end of the shaft.

Assembling Crankcase Half

1. Install the oil pump gerotor assembly and oil pump cover into the crankcase and secure with two cap screws. Coat the threads with blue Loctite #243 and tighten securely to 8.5 ft-lb.

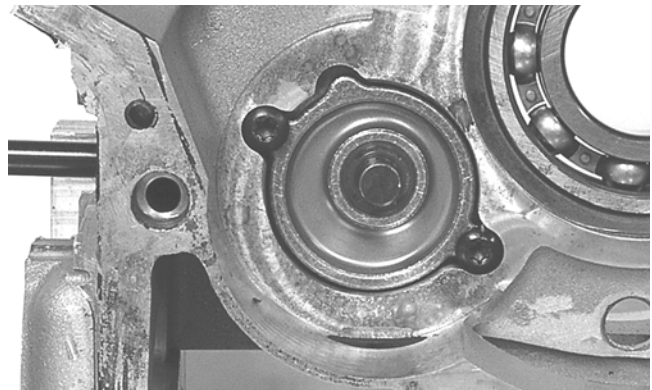

GZ305

2. Install a flat washer, drive pin, and drive gear onto the oil pump shaft; then secure with a snap ring (flat-side away from the gear).

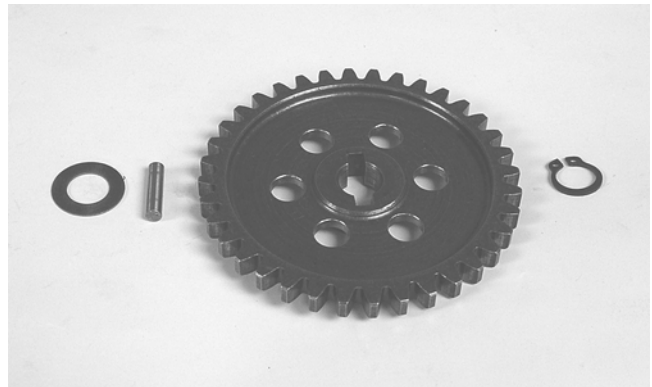

GZ347

3. Install the countershaft into the crankcase and secure with the snap ring (flat side away from the bearing).

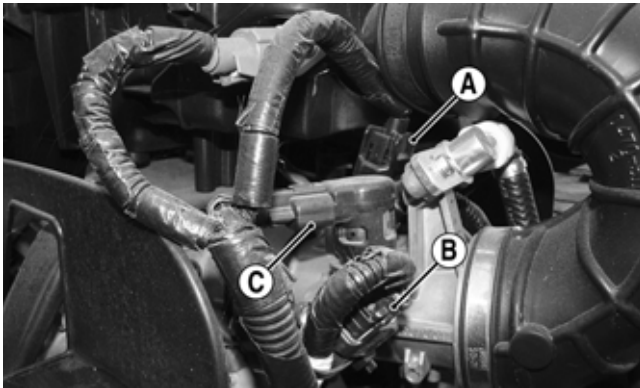

PR971B

- Loosen the clamp securing the throttle body to the intake manifold flange; then remove the throttle body.

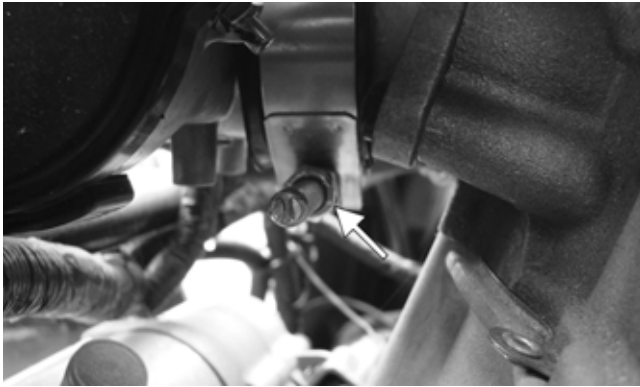

PR983A

- Use tape to cover and seal the intake opening.

CAUTION

Any objects or liquid entering the intake opening will fall into the engine causing severe damage if the engine is turned over or started.

INSTALLING

- Align the rubber intake boot to the intake manifold flange; then align the throttle body to the rubber intake boot. Tighten the boot clamp securely.

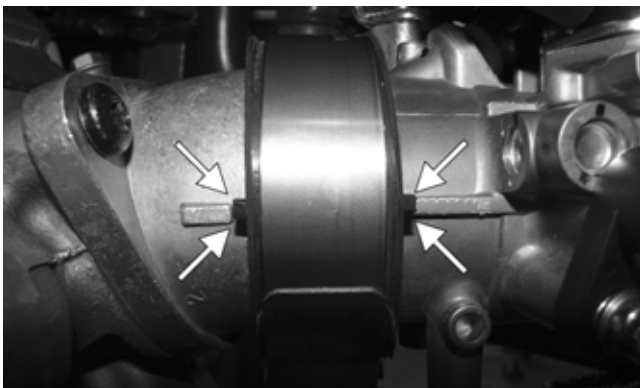

CF694A

- Connect the harness connectors to the TPS, ISC, MAP and Fuel Injector. Connect the fuel hose to the fuel rail.
- Connect the throttle cable to the throttle body and adjust throttle cable free-play.

- Connect the intake elbow to the air filter housing and throttle; then secure the two clamps.
- Install the seat bases, center console, and seats making sure the seats lock securely in place.

Throttle Body (1000)

REMOVING

- Turn the ignition switch to the OFF position; then remove the ignition switch key.

⚠ WARNING

Do not turn the ignition switch to the ON position with the hoses removed. Gasoline will be pumped by the electric fuel pump causing a safety hazard.

- Remove the left and right seats; then remove the center console and disconnect the battery.
- Remove the air inlet boot; then disconnect the throttle position sensor (TPS) connector (A), manifold absolute pressure (MAP) sensor connector (B), and idle speed control (ISC) connector (C).

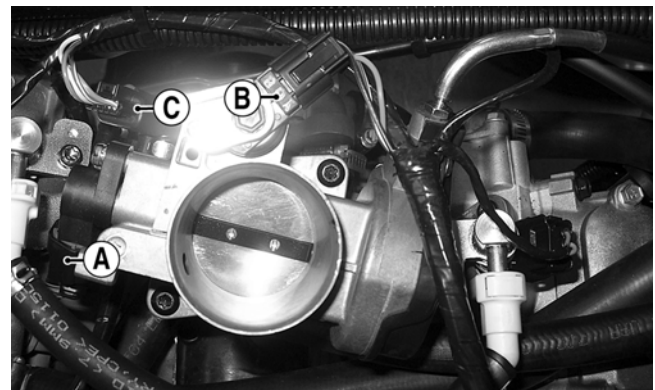

GZ094E

- Remove the cap screws securing the throttle body to the manifold; then lift the throttle body off the manifold. Account for an O-ring.



GZ386

- Remove the screw securing the throttle actuator cover to the throttle body; then remove the cover.
- Remove the throttle cable from the actuator arm.
- Loosen the outer jam nut securing the throttle cable to the throttle body. The throttle body can now be removed from the vehicle.

Electrical System

The electrical connections should be checked periodically for proper function.

TESTING ELECTRICAL COMPONENTS

All electrical tests should be made using the CATT II or the Fluke Model 77 Multimeter. The CATT II can return data for certain components which are identified at the beginning of their respective sub-section. If any other type of meter is used, readings may vary due to internal circuitry. When troubleshooting a specific component, always verify first that the fuse(s) are good, that the LED(s) are good, that the connections are clean and tight, that the battery is fully charged, and that all appropriate switches are activated.

■NOTE: For absolute accuracy, all tests should be made at room temperature of 68° F.

SPECIAL TOOLS

A number of special tools must be available to the technician when performing service procedures in this section. Refer to the current Special Tools Catalog for the appropriate tool description.

■NOTE: When indicated for use, each special tool will be identified by its specific name, as shown in the chart below, and capitalized.

Description	p/n
Ignition Test Plug	0144-306
Fluke Model 77 Multimeter	0644-559
Timing Light	0644-296
MaxiClips	0744-041
TPS Analyzer	0644-299

■NOTE: Special tools are available from the Arctic Cat Service Department.

Battery



Component data can be retrieved using the CATT II. Utilize the Sensor Data screen.

The battery is located in a compartment in front of the left-rear wheel under the driver seat.

■NOTE: To access the battery box, the driver's seat must be removed.

After being in service, batteries require regular cleaning and recharging in order to deliver peak performance and maximum service life. The following procedures are recommended for cleaning and maintaining lead-acid batteries. Always read and follow instructions provided with battery chargers and battery products.

■NOTE: Refer to all warnings and cautions provided with the battery or battery maintainer/charger.

Loss of battery charge may be caused by ambient temperature, ignition OFF current draw, corroded terminals, self discharge, frequent start/stops, and short engine run times. Frequent winch usage, snowplowing, extended low RPM operation, short trips, and high amperage accessory usage are also reasons for battery discharge.

CHARGING

■NOTE: Arctic Cat recommends the use of the CTEK Multi US 800 or the CTEK Multi US 3300 for battery maintenance charging.

1. Be sure the battery and terminals have been cleaned with a baking soda and water solution.
2. Be sure the charger and battery are in a well-ventilated area and ensure the battery charger cables will not contact any battery acid. Be sure the charger is unplugged from the 110-volt electrical outlet.
3. Connect the red terminal lead from the charger to the positive terminal of the battery; then connect the black terminal lead of the charger to the negative terminal of the battery.
4. Plug the charger into a 110-volt electrical outlet.
5. By pushing the Mode button (A) on the left side of the charger, select the Normal Charge Icon (E). The Normal Charge Indicator (C) should illuminate on the upper left portion of the charger.

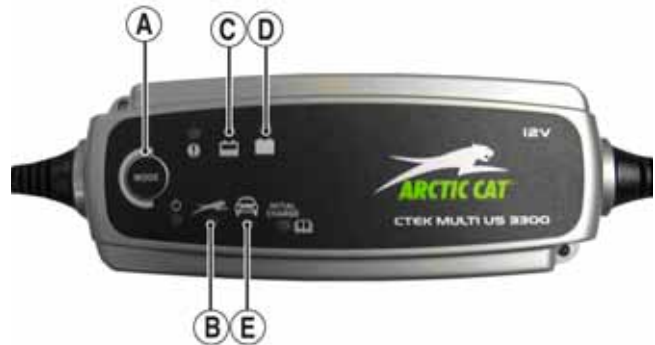

3300A

6. The battery will charge to 95% of its capacity at which time the Maintenance Charge Indicator (D) will illuminate.

■NOTE: For optimal charge and performance, leave the charger connected to the battery for a minimum 1 hour after the Maintenance Charge Indicator (D) illuminates. If the battery becomes hot to the touch, stop charging. Resume after it has cooled.

7. Once the battery has reached full charge, unplug the charger from the 110-volt electrical outlet.

■NOTE: If, after charging, the battery does not perform to operator expectations, bring the battery to an authorized Arctic Cat dealer for further troubleshooting.

TILT SENSOR

WARNING

Incorrect installation of the tilt sensor could cause sudden loss of engine power which could result in loss of vehicle control resulting in injury or death.

CAUTION

Do not drop the tilt sensor as shock can damage the internal mechanism.

The tilt sensor is located on the battery box.

Supply Voltage

1. Disconnect the three-wire connector from the sensor; then select DC Voltage on the multimeter and connect the red tester lead to the orange wire (C) and the black tester lead to the pink/black (1000) or black (700) wire (A).

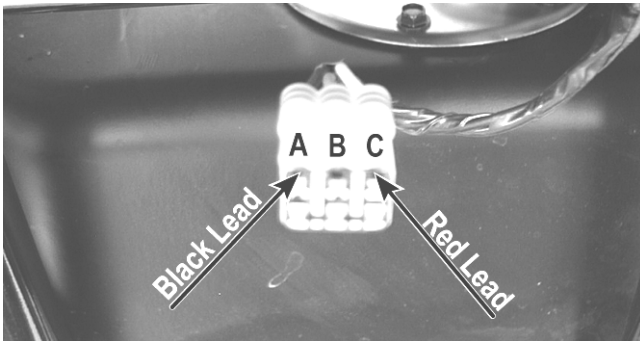

CD706A

2. Turn the ignition switch to the ON position. The multimeter should read battery voltage. If battery voltage is not indicated, check the 30-amp fuse, wiring harness, or the ignition switch.
3. Remove the red tester lead and connect to the blue/brown wire (B). The multimeter will typically read <0.2 DC volts. If the specified voltage is not indicated, check wire connections at the ECM or substitute another ECM to verify the test.

Output Voltage

■NOTE: Needle adapters will be required on the multimeter leads as the following tests are made with the sensor connected.

1. Connect the three-wire plug to the sensor; then remove the right-side mounting screw securing the sensor to the battery box.

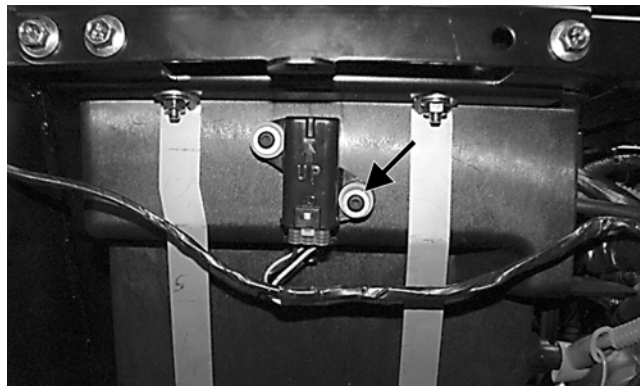

PR702A

2. Install the needle adapters to the multimeter leads; then select DC Voltage on the multimeter.
3. Connect the red tester lead to the blue/brown wire (B) and the black tester lead to the pink/black (1000) or black (700) wire (A); then turn the ignition switch ON and observe the meter. The meter should read 0.3-2.9 DC volts.

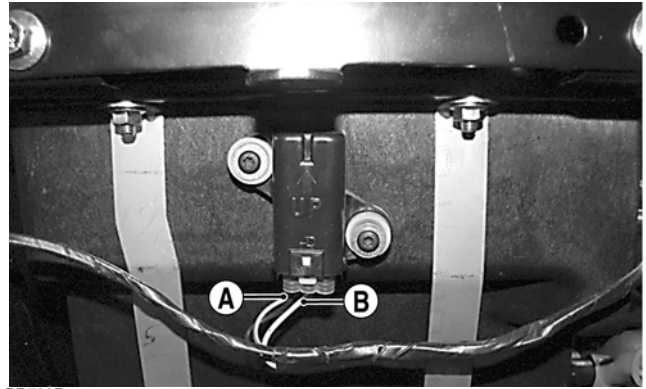

PR703B

4. Tilt the sensor 60° or more to the left and right observing the meter. The meter should read 3.0-8.0 DC volts after approximately one second in the tilted position. If the meter readings are not as specified, the tilt sensor is defective.

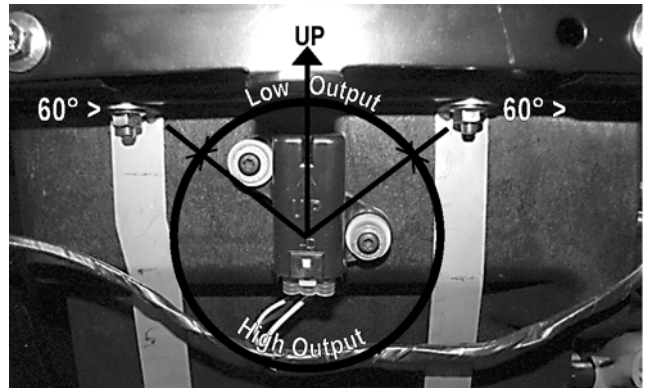

PR703A

■NOTE: When replacing the sensor after testing, make sure the arrow marking is directed up.

ENGINE COOLANT TEMPERATURE (ECT) SENSOR



Component data can be retrieved using the CATT II. Utilize the Sensor Data screen.

1. Connect the meter leads (selector in OHMS position) to the sensor terminals.
2. Suspend the sensor and a thermometer in a container of cooking oil; then heat the oil.

■NOTE: Neither the sensor nor the thermometer should be allowed to touch the bottom of the container or inaccurate readings will occur. Use wire holders to suspend the sensor and thermometer.

Problem: Spark plug electrodes overheat or burn	
Condition	Remedy
<ol style="list-style-type: none"> 1. Spark plug(s) incorrect (too hot) 2. Engine overheats 3. Spark plug(s) loose 	<ol style="list-style-type: none"> 1. Replace plug(s) 2. Service cooling system 3. Tighten plug(s)
Problem: Battery does not charge	
Condition	Remedy
<ol style="list-style-type: none"> 1. Lead wires/connections shorted - loose - open 2. Stator coils shorted - grounded - open 3. Regulator/rectifier shorted 	<ol style="list-style-type: none"> 1. Repair - replace - tighten lead wires 2. Replace stator coils 3. Replace regulator/rectifier
Problem: Battery charges, but charging rate is below the specification	
Condition	Remedy
<ol style="list-style-type: none"> 1. Lead wires shorted - open - loose (at terminals) 2. Stator coils grounded - open 3. Regulator/rectifier defective 4. Electrolyte low 5. Cell plates (battery) defective 	<ol style="list-style-type: none"> 1. Repair - tighten lead wires 2. Replace stator coils 3. Replace regulator/rectifier 4. Add distilled water 5. Replace battery
Problem: Magneto overcharges	
Condition	Remedy
<ol style="list-style-type: none"> 1. Internal battery short circuited 2. Regulator/rectifier defective 3. Regulator/rectifier poorly grounded 	<ol style="list-style-type: none"> 1. Replace battery 2. Replace regulator/rectifier 3. Clean - tighten ground connection
Problem: Charging unstable	
Condition	Remedy
<ol style="list-style-type: none"> 1. Lead wire intermittently shorting 2. Magneto internally shorted 3. Regulator/rectifier defective 	<ol style="list-style-type: none"> 1. Replace lead wire 2. Replace stator coil 3. Replace regulator/rectifier
Problem: Starter does not engage	
Condition	Remedy
<ol style="list-style-type: none"> 1. Battery charge low 2. Switch contacts defective 3. Starter motor brushes not seating 4. Starter relay defective 5. Emergency stop - ignition switch off 6. Wiring connections loose - disconnected 7. Start-in-gear/neutral relay defective 	<ol style="list-style-type: none"> 1. Recharge - replace battery 2. Replace switch 3. Replace starter 4. Replace relay 5. Turn on switches 6. Connect - tighten - repair connections 7. Replace relay
Problem: Battery "sulfation" (Acidic white powdery substance or spots on surfaces of cell plates)	
Condition	Remedy
<ol style="list-style-type: none"> 1. Charging rate too low - too high 2. Battery electrolyte insufficient 3. Specific gravity too low 4. Battery discharged 5. Electrolyte contaminated 	<ol style="list-style-type: none"> 1. Replace battery 2. Keep electrolyte to prescribed level 3. Charge battery - add distilled water 4. Charge battery 5. Replace battery
Problem: Battery discharges too rapidly	
Condition	Remedy
<ol style="list-style-type: none"> 1. Electrolyte contaminated 2. Specific gravity low 3. Charging system (charging operation) not set properly 4. Cell plates overcharged - damaged 5. Battery short-circuited 6. Electrical load too high 	<ol style="list-style-type: none"> 1. Replace battery 2. Charge battery - add distilled water 3. Check AC generator - regulator/rectifier - circuit connections 4. Replace battery - correct charging system 5. Replace battery 6. Reduce load
Problem: Battery polarity reversed	
Condition	Remedy
<ol style="list-style-type: none"> 1. Battery incorrectly connected 	<ol style="list-style-type: none"> 1. Reverse connections - replace battery

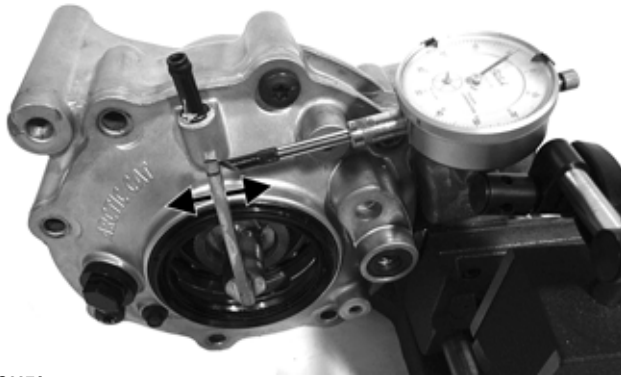

GC037A

Ring Gear End-Play

After correcting backlash, ring gear end-play can be adjusted. To adjust end-play, use the following procedure.

1. Secure the gear case in a holding fixture with the cover side up; then install a dial indicator contacting the ring gear axle flange.

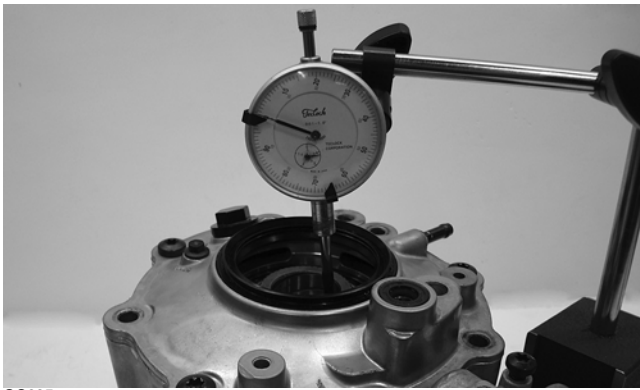

GC035

2. Zero the dial indicator; then push the ring gear toward the dial indicator and release. End-play should be 0.004-0.008 in.
3. To increase end-play, decrease the shim thickness. To decrease end-play, increase the shim thickness.

■NOTE: Once proper backlash and end play are established, the gear case can be assembled (see Assembling Differential Assembly in this sub-section).

RING GEAR/THRUST BUTTON

Removing

Remove the thrust button from the gear case cover (left-hand threads). Account for a shim.

Inspecting

1. Inspect the ring gear for excessive wear or discoloration.
2. Inspect the thrust button for excessive wear or discoloration.
3. Inspect the bearings for discoloration, roughness, or excessive wear.

Installing/Shimming

■NOTE: Ring gear end-play must be adjusted prior to selecting shim for the thrust button.

1. Install the thrust button with shim into the gear case cover and tighten securely (left-hand threads).

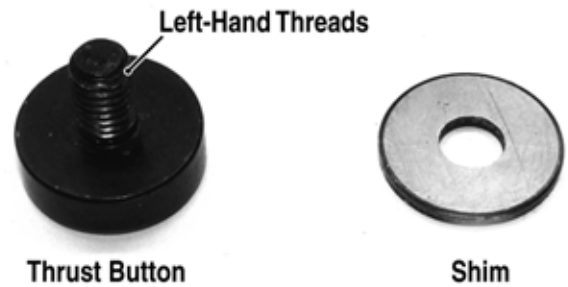

GC057A

2. Place the ring gear with selected shim into the cover and measure the ring gear to thrust button clearance with a thickness gauge. Clearance should be 0.020-0.040 in.

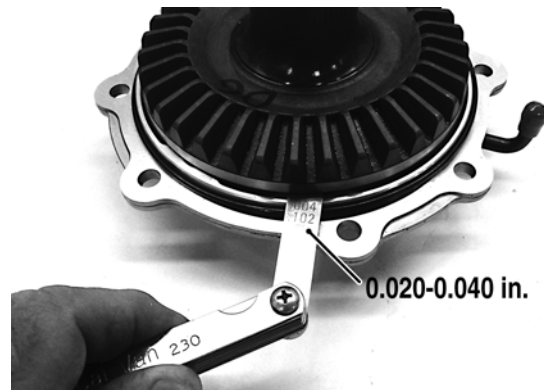

GC058A

3. If clearance is as specified, remove the ring gear and thrust button; then place a drop of red Loctite #271 on the threads and tighten to 9 ft-lb (left-hand threads).
4. If clearance is not as specified, repeat steps 1 and 2 using thicker (clearance too great) or thinner (clearance too small) until correct specification is reached.

Assembling Differential Assembly

1. With the pinion gear and new bearings installed, place the selected (backlash) shim on the gear case side of the ring gear with the chamfered side toward the ring gear; then install into gear case/differential housing.



GC031A



HDX384

4. Remove the snap ring retaining the input bearing and, using an appropriate bearing driver, press the bearing from the housing.



HDX385

Cleaning and Inspecting

1. Wash all parts in parts cleaning solvent and dry with compressed air.

WARNING

Always wear safety glasses when working with compressed air.

2. Clean all gasket material and sealant from mating surfaces.
3. Inspect bearings, shafts, and housing for excessive wear, cracks, or discoloration.
4. Inspect the clutch basket (1000) for wear in splines or cracks in the housing.

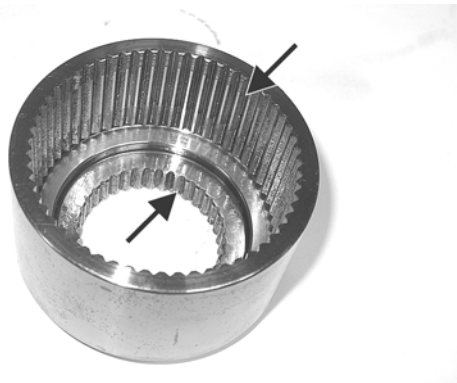

GZ178A

5. Inspect the clutch pack (1000) for signs of discoloration.

■NOTE: The clutch pack is not a serviceable component. If worn, discolored, or damaged in any way, it must be replaced.

Assembling/Installing - 1000

1. Install a new bearing into the input housing and secure with the snap ring (flat side directed away from bearing).



GZ184

2. Using a suitable seal driver, install a new oil seal into the front of the input housing until the seal is flush with the housing.

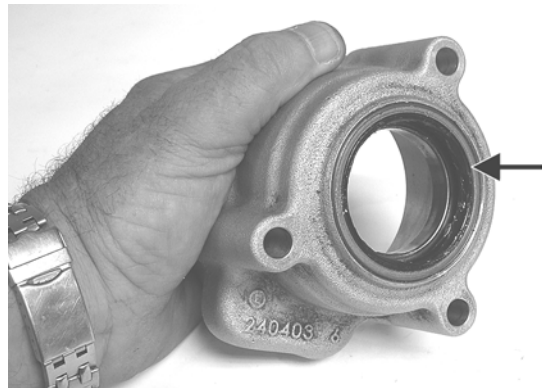

GZ182A

3. Apply grease to the lips of the oil seal; then install the input shaft into the input bearing and housing.

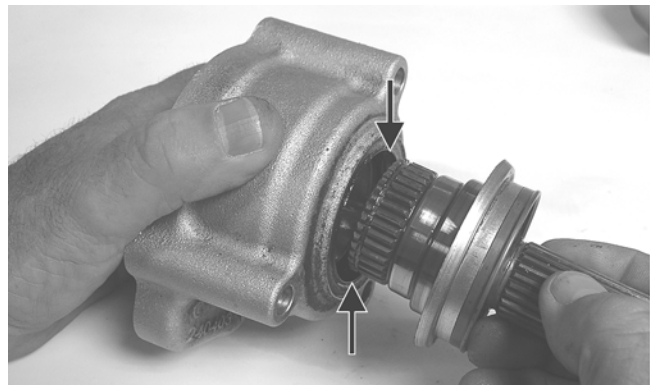

GZ179A

4. Install the clutch basket onto the input shaft and secure with the snap ring (flat side directed outward); then install the clutch pack into the basket.

CLICK HERE TO **DOWNLOAD** THE COMPLETE MANUAL

- Thank you very much for reading the preview of the manual.
- You can download the complete manual from: www.heydownloads.com by clicking the link below



- Please note: If there is no response to CLICKING the link, please download this PDF first and then click on it.

CLICK HERE TO **DOWNLOAD** THE COMPLETE MANUAL