

2017

SERVICE MANUAL



ALTERRA 700/XT

CLICK HERE TO **DOWNLOAD** THE COMPLETE MANUAL

- Thank you very much for reading the preview of the manual.
- You can download the complete manual from: www.heydownloads.com by clicking the link below



- Please note: If there is no response to CLICKING the link, please download this PDF first and then click on it.

CLICK HERE TO **DOWNLOAD** THE COMPLETE MANUAL

Front Differential/Rear Drive Lubricant

CAUTION

Any lubricant used in place of the recommended gear lube could result in premature failure of the shock limiter. Do not use any lubricant containing graphite or molybdenum additives or other friction-modified lubricants as these may cause severe damage to shock limiter components.

When changing the lubricant, use approved SAE 80W-90 hypoid gear lube.

To check lubricant, remove the fill plug; the lubricant level should be 1 in. below the threads of the plug. If low, add SAE approved 80W-90 hypoid gear lubricant as necessary.

To change the lubricant, use the following procedure.

1. Place the ATV on level ground.
2. Remove each oil filler plug.
3. Drain the oil into a drain pan by removing in turn the drain plug from each.

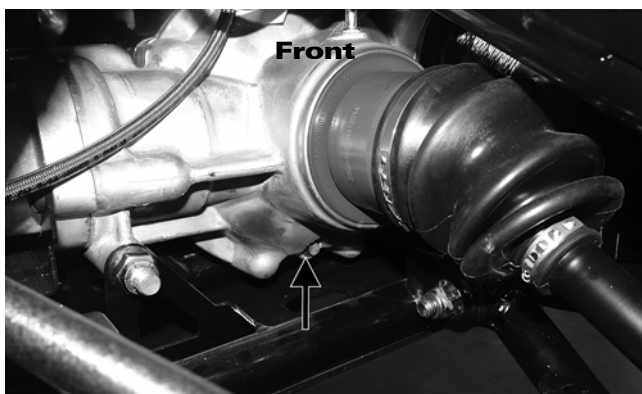

XR019A

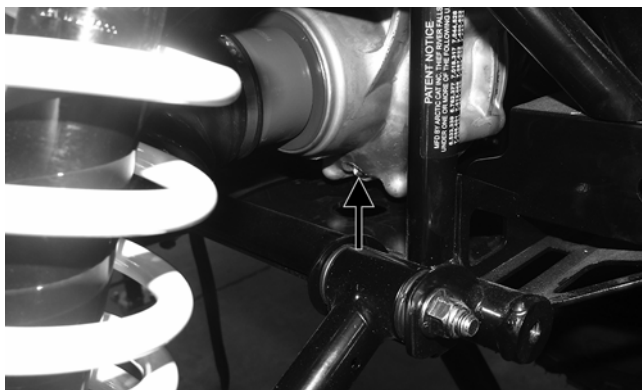

XR017A

4. After all the oil has been drained, install the drain plugs and tighten securely.

CAUTION

Inspect the oil for any signs of metal filings or water. If found, take the ATV to an authorized Arctic Cat ATV dealer for servicing.

5. Pour recommended oil into each filler hole.

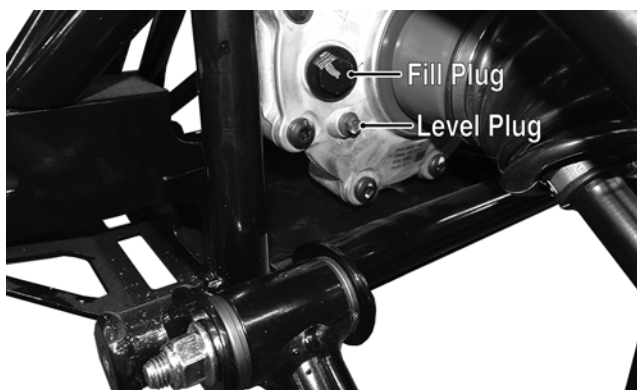

XR022A

■NOTE: Arctic Cat recommends the use of genuine Arctic Cat lubricants.

6. Install the filler plugs.

Shift Lever

CHECKING ADJUSTMENT

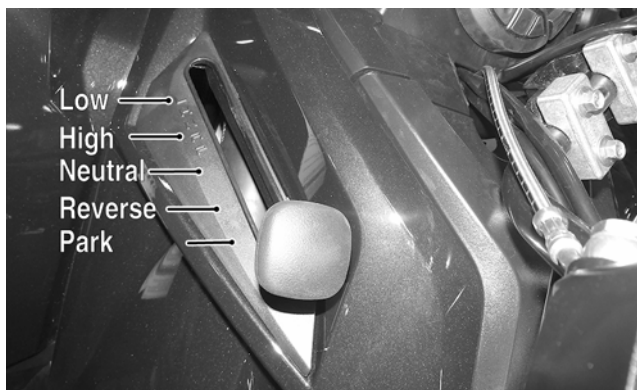

XR004A

WARNING

Never shift the ATV into reverse gear when the ATV is moving as it could cause the ATV to stop suddenly throwing the operator from the ATV.

ADJUSTING SHIFT LEVER

1. Remove the seat and left side panel.
2. With the ignition switch in the ON position, loosen jam nut (A) (left-hand threads); then loosen jam nut (C) and with the shift lever in the reverse position, adjust the coupler (B) until the transmission is in reverse and the (R) icon appears on the LCD.

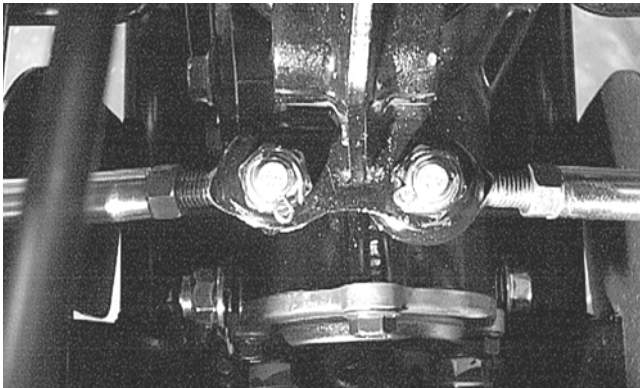

AF778D

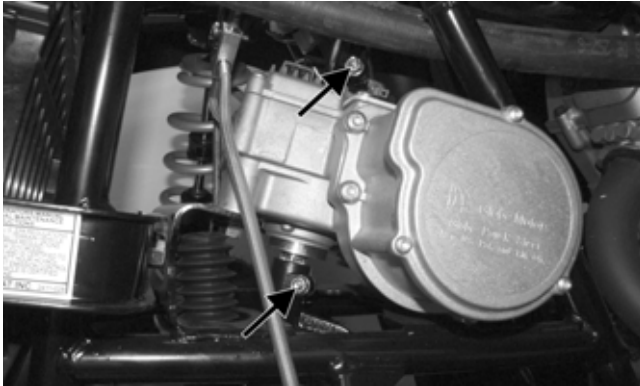

EPS005A

4. Connect the 2-pin and 8-pin connectors to the EPS assembly.
5. Install the steering post housing with plate to the frame and secure with two cap screws. Tighten to 20 ft-lb.
6. Install the handlebar and secure with the handlebar caps. Tighten the screws to 25 ft-lb.
7. Install the shock absorber and tighten to 50 ft-lb.
8. Install the handlebar cap; then install the console and gauge

Handlebar Grip

REMOVING

1. Loosen but do not remove the cap screws in the end of the handlebar; then tap lightly on the head to dislodge the handlebar plug.



XR121

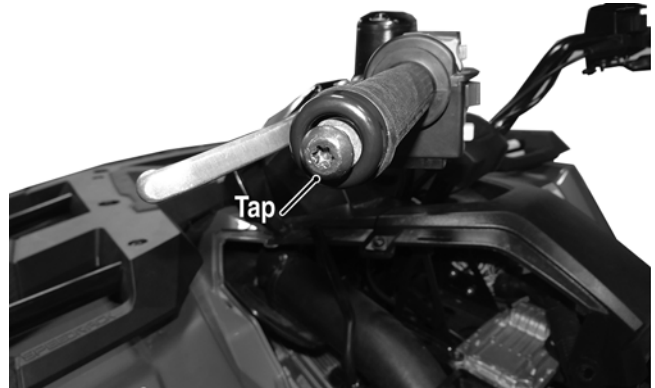

XR123A

2. Grasp the end and remove the cap screw, plug, and end cap.

INSPECTING

1. Inspect the grip for wear, cuts, or cracks.
2. Inspect the grip for deterioration.
3. If a grip is damaged, cut the grip lengthwise using a sharp knife or box cutter; then peel off the grip.

INSTALLING

■ **NOTE:** Before installing a grip, use contact removal spray or alcohol to clean the handlebar of glue residue, oil, or any other contaminant.

1. Apply a liberal amount of Handlebar Grip Adhesive to the inside of a new grip.
2. Slide the grip onto the handlebar until it is fully seated with the smooth part of the grip facing up.
3. Wipe off any excess glue; then secure the grip with the handlebar end-cap.

Throttle Control

REMOVING

1. Remove the two machine screws securing the throttle control to the handlebar.
2. Slide the grommet out of the lower half of the throttle control; then remove the cable from the actuator arm.

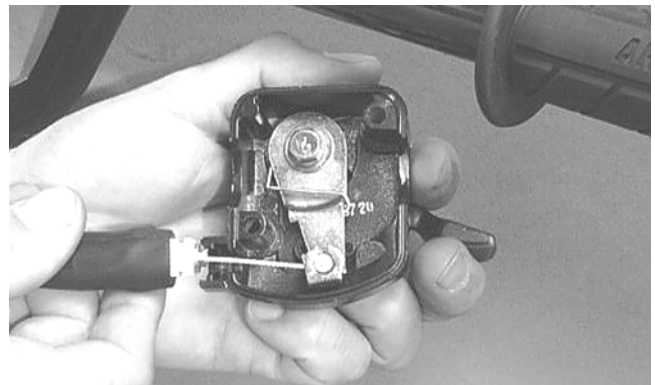

AF676D

3. Remove the cap screw, lock washer, and washer securing the actuator arm to the throttle control lever.

Problem: Engine noisy (Noise seems to come from secondary bevel gear and final driven shaft)	
Condition	Remedy
<ol style="list-style-type: none"> 1. Drive - driven bevel gears damaged - worn 2. Backlash incorrect 3. Tooth contact improper 4. Bearing damaged 5. Gears worn 6. Splines worn 	<ol style="list-style-type: none"> 1. Replace gears 2. Adjust backlash 3. Adjust contact 4. Replace bearing 5. Replace gears 6. Replace shaft(s)
Problem: Engine idles poorly	
Condition	Remedy
<ol style="list-style-type: none"> 1. Gasoline bad - contaminated 2. Valve clearance incorrect 3. Valve seating poor 4. Valve guides defective 5. Rocker arms - arm shaft worn 6. Magneto defective 7. ECM defective 8. Spark plug fouled - gap incorrect 9. Ignition coil defective 10. Fuel injector obstructed 	<ol style="list-style-type: none"> 1. Drain gas - replace with clean gas 2. Adjust clearance 3. Replace - service seats - valves 4. Replace guides 5. Replace arms - shafts 6. Replace stator coil 7. Replace ECM 8. Adjust gap - replace plug 9. Replace ignition coil 10. Replace fuel injector
Problem: Engine runs poorly at high speed	
Condition	Remedy
<ol style="list-style-type: none"> 1. Gasoline bad - contaminated 2. High RPM "cut out" against RPM limiter 3. Valve springs weak 4. Valve timing incorrect 5. Cams - rocker arms - tappets worn 6. Spark plug gap incorrect 7. Ignition coil defective 8. Fuel pump defective 9. Air cleaner element obstructed 10. Fuel hose obstructed 	<ol style="list-style-type: none"> 1. Drain gas - replace with clean gas 2. Shift into higher gear - decrease speed 3. Replace springs 4. Time valves 5. Replace cams - arms - tappets 6. Adjust gap 7. Replace ignition oil 8. Replace fuel pump 9. Clean element 10. Clean or replace hose
Problem: Exhaust smoke dirty or heavy	
Condition	Remedy
<ol style="list-style-type: none"> 1. Gasoline bad - contaminated 2. Engine oil overfilled - contaminated 3. Piston rings - cylinder worn 4. Valve guides worn 5. Cylinder wall scored 6. Valve stems worn 7. Stem seals defective 	<ol style="list-style-type: none"> 1. Drain gas - replace with clean gas 2. Drain excess oil - replace oil 3. Replace - service rings - cylinder 4. Replace guides 5. Replace - service cylinder 6. Replace valves 7. Replace seals
Problem: Engine lacks power	
Condition	Remedy
<ol style="list-style-type: none"> 1. Gasoline bad - contaminated 2. Valve and/or combustion chamber carbon build-up 3. Valve clearance incorrect 4. Valve springs weak 5. Valve timing incorrect 6. Piston ring(s) - cylinder worn 7. Valve seating poor 8. Spark plug fouled 9. Rocker arms - shafts worn 10. Spark plug gap incorrect 11. Fuel injector obstructed 12. Cam chain worn 13. Air cleaner element obstructed 14. Engine oil overfilled - contaminated 15. Intake manifold leaking air 	<ol style="list-style-type: none"> 1. Drain gas - replace with clean gas 2. Run combustion chamber cleaner or clean combustion chamber 3. Adjust clearance 4. Replace springs 5. Re-time valve gear 6. Replace - service rings - cylinder 7. Repair seats 8. Clean - replace plug 9. Replace arms - shafts 10. Adjust gap - replace plug 11. Replace injector 12. Replace cam chain 13. Clean element 14. Drain excess oil - change oil 15. Tighten - replace manifold
Problem: Engine overheats	
Condition	Remedy
<ol style="list-style-type: none"> 1. Radiator obstructed 2. Radiator hoses - cap damaged - obstructed 3. Fan malfunctioning 4. Fan relay malfunctioning 5. Thermostat stuck - closed 6. Coolant level low 7. Octane low - gasoline poor 8. Intake manifold leaking air 9. Carbon deposit (piston crown) excessive 10. Oil low 11. Oil pump defective 12. Oil circuit obstructed 	<ol style="list-style-type: none"> 1. Clean radiator 2. Clear obstruction - replace hoses 3. Replace fan relay 4. Check fan fuse - replace fan 5. Replace thermostat 6. Fill - examine system for leaks 7. Drain - replace gasoline 8. Tighten - replace manifold 9. Clean piston 10. Add oil 11. Replace pump 12. Clean circuit

Cleaning/Inspecting Cylinder Head

CAUTION

The cylinder head studs must be removed for this procedure.

1. Using a non-metallic carbon removal tool, remove any carbon buildup from the combustion chamber being careful not to nick, scrape, or damage the combustion chamber or the sealing surface.
2. Inspect the spark plug hole for any damaged threads. Repair damaged threads using a “heli-coil” insert.
3. Place the cylinder head on the Surface Plate covered with #400 grit wet-or-dry sandpaper. Using light pressure, move the cylinder head in a figure eight motion. Inspect the sealing surface for any indication of high spots. A high spot can be noted by a bright metallic finish. Correct any high spots before assembly by continuing to move the cylinder head in a figure eight motion until a uniform bright metallic finish is attained.

CAUTION

Water or parts-cleaning solvent must be used in conjunction with the wet-or-dry sandpaper or damage to the sealing surface may result.

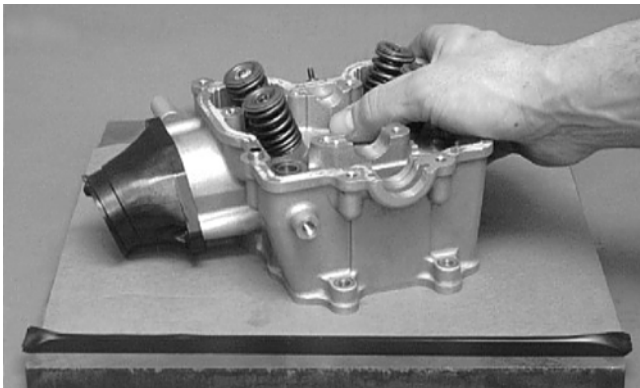

CC128D

Measuring Cylinder Head Distortion

1. Remove any carbon buildup in the combustion chamber.
2. Lay a straightedge across the cylinder head; then using a feeler gauge, check the distortion factor between the head and the straightedge.
3. Maximum distortion must not exceed specifications.

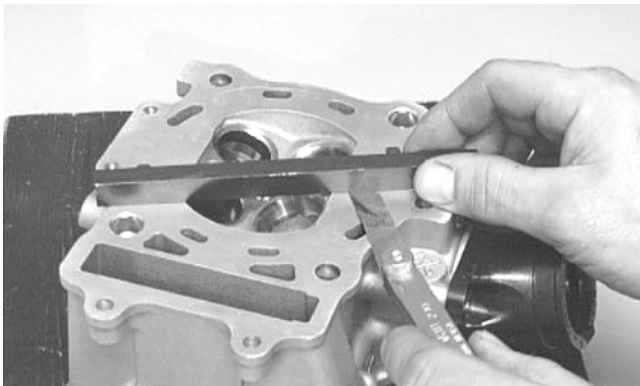

CC141D

Cleaning/Inspecting Cylinder

1. Wash the cylinder in parts-cleaning solvent.
2. Inspect the cylinder for pitting, scoring, scuffing, warpage, and corrosion. If marks are found, repair the surface using a cylinder hone (see Inspecting Cylinder in this sub-section).
3. Place the cylinder on the surface plate covered with #400 grit wet-or-dry sandpaper. Using light pressure, move the cylinder in a figure eight motion. Inspect the sealing surface for any indication of high spots. A high spot can be noted by a bright metallic finish. Correct any high spots before assembly by continuing to move the cylinder in a figure eight motion until a uniform bright metallic finish is attained.

CAUTION

Water or parts-cleaning solvent must be used in conjunction with the wet-or-dry sandpaper or damage to the sealing surface may result.

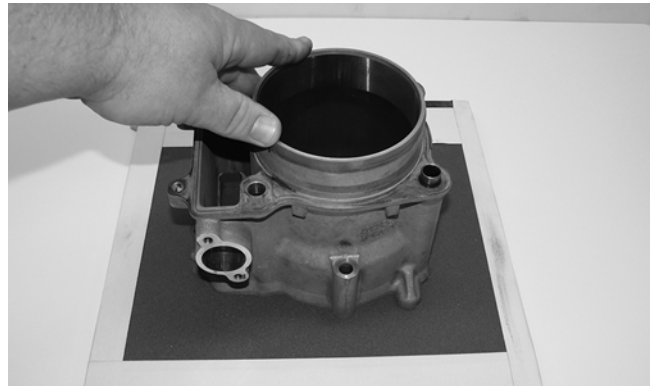

H1-039

Inspecting Cam Chain Guide

1. Inspect cam chain guide for cuts, tears, breaks, or chips.
2. If the chain guide is damaged, it must be replaced.

Inspecting Cylinder

1. Using a slide gauge and a dial indicator or a snap gauge, measure the cylinder bore diameter in three locations from top to bottom and again from top to bottom at 90° from the first measurements for a total of six measurements. The trueness (out-of-roundness) is the difference between the highest and lowest reading. Maximum trueness (out-of-roundness) must not exceed specifications.

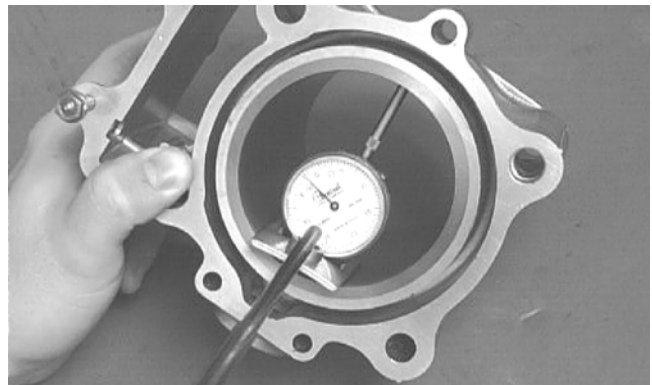

CC127D



FI583

2. Thoroughly clean the gear hub; then apply a drop of green Loctite #620 to the bearing outer race and press into the gear hub until even with the lower chamfer radius.



FI580

INSPECTING STATOR COIL/MAGNETO COVER ASSEMBLY

1. Inspect the stator coil for burned or discolored wiring, broken or missing hold-down clips, or loose cap screws.
2. Inspect the bearings in the magneto housing for discoloration, roughness when rotated, and secure fit in bearing bores.

REPLACING STATOR COIL/ CRANKSHAFT POSITION SENSOR

1. Remove the three cap screws securing the stator coil, two cap screws securing the crankshaft position sensor, and one cap screw from the harness hold-down.
2. Lift the rubber grommet out of the housing; then remove the stator coil/crankshaft position sensor. Account for and note the position of the harness hold-down under the crankshaft position sensor.

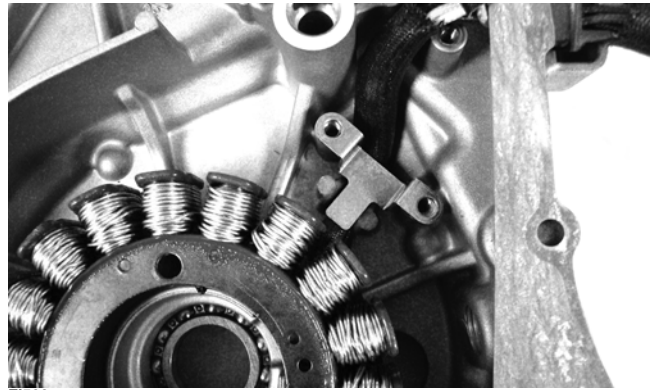

FI590

3. Install the new stator coil assembly and secure with three new "patch-lock" cap screws. Tighten to 15 ft-lb.
4. Place the stator wire harness hold-down into position; then install the crankshaft position sensor and secure with two cap screws. Tighten securely.
5. Install the upper cable hold-down and secure with a cap screw. Tighten securely.

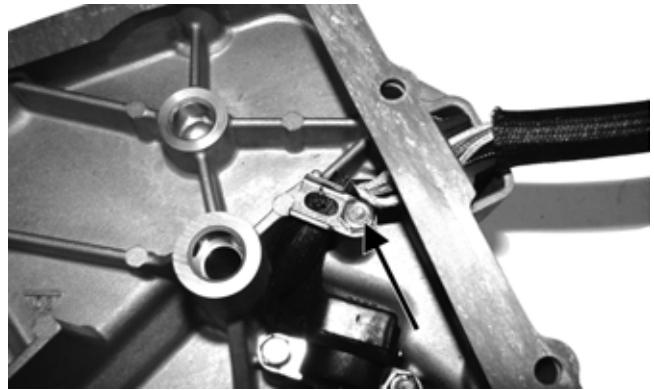

FI595A

Installing Left-Side Components

■NOTE: Plug the oil passage in the crankcase housing prior to installing the drive gear/driven gear assembly to prevent loss of an alignment pin.

1. Install the water pump driven gear alignment pin and the driven gear (with the beveled side of the gear facing outward as noted in removing); then secure with the snap ring.

CLICK HERE TO **DOWNLOAD** THE COMPLETE MANUAL

- Thank you very much for reading the preview of the manual.
- You can download the complete manual from: www.heydownloads.com by clicking the link below



- Please note: If there is no response to CLICKING the link, please download this PDF first and then click on it.

CLICK HERE TO **DOWNLOAD** THE COMPLETE MANUAL

5. Install the centering bushing into the fixed driven hub; then with the sharp side upward, place the snap ring onto the assembly and install the compression yoke and wing nut.



WC414

6. Turn the wing nut clockwise to compress the spring being very careful that the cam correctly engages the fixed driven hub; then continue to tighten until the cam ramps are just above the cam shoes.

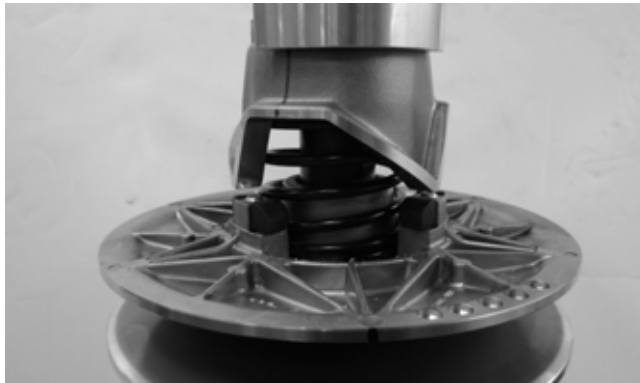

WC398

7. Rotate the cam counterclockwise by hand enough to get the cam ramps on the correct side of the cam shoes; then continue to tighten the wing nut until the keyways align.

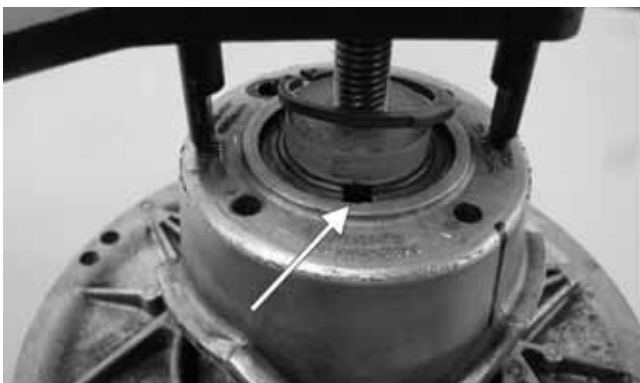

WC411A

8. Install the square key making sure it fits flush and clear of the snap ring groove; then install the snap ring making sure it is seated properly.

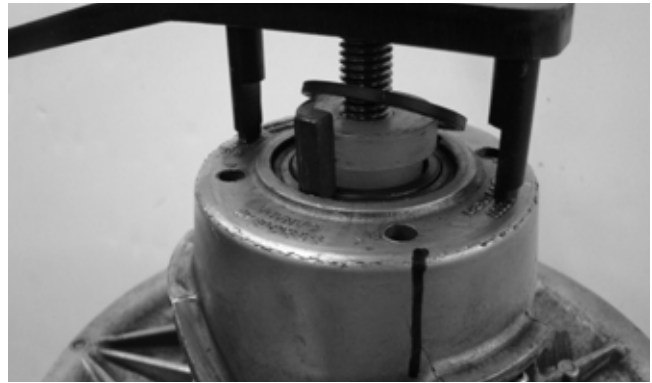

WC412

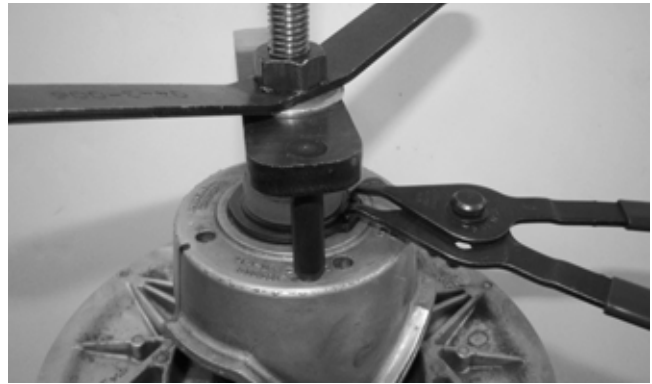

WC419

9. Turn the wing nut counterclockwise slowly allowing the cam to contact the snap ring; then loosen slightly and tap the cam with a plastic mallet to ensure the snap ring is securely seated.



WC408

10. Remove the wing nut, compression yoke, and centering bushing; then remove the driven pulley assembly from the Clutch Spring Compressor.

Installing Right-Side Components

1. Install the gear position switch. Tighten the cap screws securely.



H1-049A

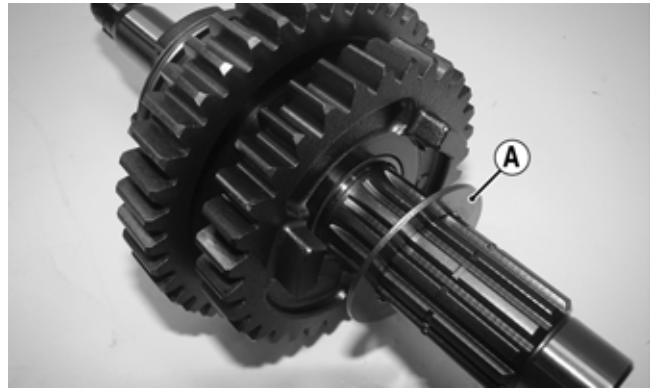

H1-045A



H1-048



H1-044

4. Install the reverse driven dog (A) onto the countershaft and secure with a new snap ring (B).



H1-047

2. Install the reverse driven gear needle bearing (C) then the reverse driven gear (B).

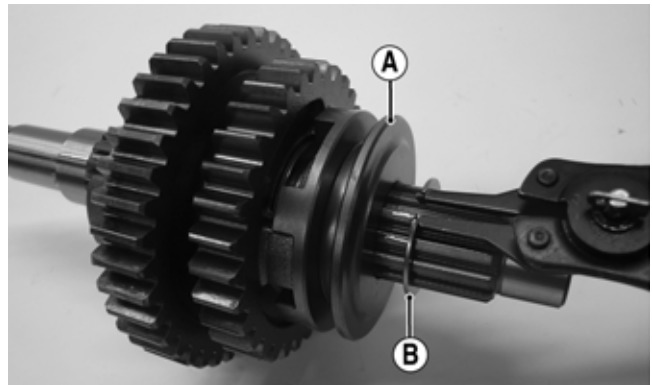

H1-043A

5. Install the drive gear.

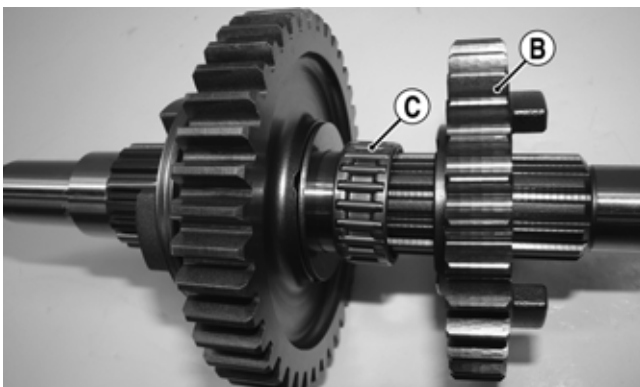

H1-046A

3. Install the outer reverse driven gear washer (A); then secure the reverse driven gear assembly with a new snap ring.

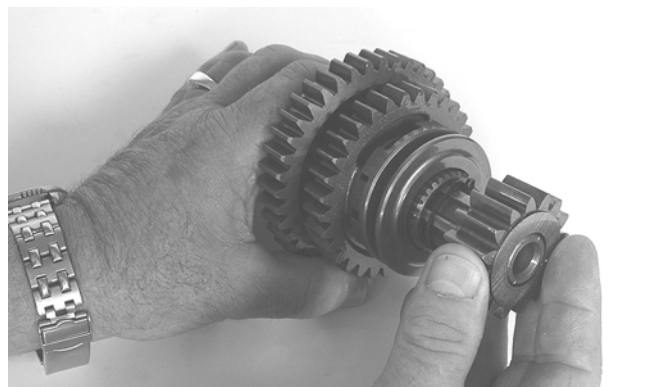

GZ296

6. From the opposite end of the countershaft, install the high/low driven gear dog (A), thrust washer (B), high driven gear (D), and spacer washer (E).

Troubleshooting

Problem: Starting impaired	
Condition	Remedy
<ol style="list-style-type: none"> 1. Battery discharged or defective 2. Gas contaminated 3. Air filter/housing contaminated 	<ol style="list-style-type: none"> 1. Test, charge, and/or replace battery 2. Drain gas tank and fill with clean gas 3. Clean or replace air filter/housing or replace
Problem: Idling or low speed impaired	
Condition	Remedy
<ol style="list-style-type: none"> 1. Gas contaminated 2. TPS out of adjustment 3. Air filter/housing contaminated 4. ISC malfunction 	<ol style="list-style-type: none"> 1. Drain gas tank and fill with clean gas 2. Adjust TPS 3. Clean or replace air filter/housing or replace 4. Inspect/replace ISC
Problem: Medium or high speed impaired	
Condition	Remedy
<ol style="list-style-type: none"> 1. Gas contaminated 2. Air filter/housing contaminated 	<ol style="list-style-type: none"> 1. Drain gas tank and fill with clean gas 2. Clean or replace air filter/housing or replace

1. Set the meter selector to the AC Voltage position and test as follows.

WIRE COLOR	VOLTAGE
Red to White	2.0 AC Volts
Black to Brown	

2. Crank the engine over using the electric starter. The meter reading must be within specification.

OXYGEN (O2) SENSOR

The sensor is located in the exhaust pipe.

1. On the right side of the ATV, unplug the connector.



XR116A

2. On the sensor side of connector, connect the black (negative) test lead to one white wire pin; then connect the red (positive) test lead to the other white wire pin.
3. With the meter in the OHMS position, the reading should be between 6.7-10.1 ohms.

■NOTE: If the meter does not read as specified, replace sensor.

TEMPERATURE/MANIFOLD ABSOLUTE PRESSURE (TMAP) SENSOR



Component data can be retrieved using the CATT II. Utilize the Sensor Data screen.

■NOTE: Preliminary checks may be performed on this component using the diagnostic mode on the LCD gauge (see EFI Diagnostic System in this section).

■NOTE: The ambient temperature of the engine and in the intake and exhaust system must be at room temperature (approximately 68° F) when performing this test or an incorrect reading will occur.

1. Disconnect the MAP/IAT connector from the sensor located on top of the throttle body.
2. Select DC Voltage on the tester and turn the ignition switch to the ON position.
3. Connect the black tester lead to the black/pink wire and the red tester lead to the orange/blue wire. The meter should read 4.5-5.5 DC volts. If the meter does not read as specified, check the ECM connector or wiring.

4. Connect the MAP/IAT to the harness; then using MaxiClips, connect the red tester lead to the brown/white wire and the black tester lead to the black/pink wire. With the engine running at idle speed, the meter should read approximately 2.5 DC volts (MAP sensor signal).

5. Connect the red tester lead to the green/red wire. With the engine at idle, the meter should read approximately 2.9 DC volts.

■NOTE: If the meter does not read as specified, replace the sensor.

ENGINE COOLANT TEMPERATURE (ECT) SENSOR



Component data can be retrieved using the CATT II. Utilize the Sensor Data screen.

■NOTE: Preliminary checks may be performed on this component using the diagnostic mode on the LCD gauge (see EFI Diagnostic System in this section).

1. Connect the meter leads (selector in OHMS position) to the sensor terminals.
2. Suspend the sensor and a thermometer in a container of cooking oil; then heat the oil.

■NOTE: Neither the sensor nor the thermometer should be allowed to touch the bottom of the container or inaccurate readings will occur. Use wire holders to suspend the sensor and thermometer.

 **WARNING**

Wear insulated gloves and safety glasses. Heated oil can cause severe burns.

TEMPERATURE	RESISTANCE
-20° C (-4° F)	18.8k Ohms
40° C (105° F)	1.14k Ohms
100° C (212° F)	155 Ohms

3. If the readings are not as indicated $\pm 10\%$, the sensor must be replaced.
4. Install the sensor and tighten securely.
5. Connect the leads.

SPEED SENSOR



Component data can be retrieved using the CATT II. Utilize the Sensor Data screen.

■NOTE: Prior to testing the speed sensor, inspect the three-wire connector on the speed sensor for contamination, broken pins, and/or corrosion.

1. Set the meter selector to the DC Voltage position.
2. With appropriate needle adapters on the meter leads, connect the red tester lead to the orange lead; then connect the black tester lead to the black lead.

Code	Fault Description	Possible Cause	Fault Recovery Method
P0117	ECT Sensor Circuit Low/SG	Sensor or interconnect harness shorted to chassis ground	Correct condition*
P0118	ECT Sensor Circuit High/Open/SP	Sensor or interconnect harness open or shorted to battery power	Correct condition*
P0119	ECT Sensor Circuit Intermittent	Sensor or interconnect harness intermittent	Correct condition*
P0121	TPS Range/Performance	Sensor producing an out-of-range voltage	Correct condition*
P0122	TPS Circuit Low/SG	Sensor or interconnect harness shorted to chassis ground	Correct condition*
P0123	TPS Circuit High	Sensor or interconnect harness open or shorted to battery power	Correct condition*
P0130	O2 Sensor Intermittent/Open	Sensor or interconnect harness intermittent or open	Correct condition*
P0131	O2 Sensor Low/SG or Air-Leak	Sensor or interconnect harness shorted to chassis ground or an air-leak exists	Correct condition*
P0132	O2 Sensor High/SP	Sensor or interconnect harness shorted to battery power	Correct condition*
P0171	O2 Feedback Below Minimum Correction	Low fuel rail pressure, dirty fuel filter, or dirty injectors	Correct condition*
P0172	O2 Feedback Exceeds Maximum Correction	Excessive fuel rail pressure, MAP or temp sensors out-of-spec	Correct condition*
P0219	Engine Over-Speed Condition	Engine speed (RPM) has exceeded the ECM over-speed set point/limit	Reduce engine speed
P0231	Fuel Pump Relay Circuit Low/SG/Open	Relay has been removed or interconnect harness shorted to chassis ground	Correct condition*
P0232	Fuel Pump Relay Circuit High	Relay or interconnect harness shorted to battery power	Correct condition*
P0233	Fuel Pump Relay Circuit	Relay circuit erratic or intermittent	Correct condition*
P0261	Rear Cylinder Fuel injector Circuit Low/SG	Injector or interconnect harness shorted to chassis ground	Correct condition**
P0262	Rear Cylinder Fuel injector Circuit High	Injector or interconnect harness shorted to battery power	Correct condition**
P0263	Rear Cylinder Fuel injector Balance/Open	Injector has been disconnected or interconnect harness open	Correct condition**
P0264	Front Cylinder Fuel injector Circuit Low/SG	Injector or interconnect harness shorted to chassis ground	Correct condition**
P0265	Front Cylinder Fuel injector Circuit High	Injector or interconnect harness shorted to battery power	Correct condition**
P0266	Front Cylinder Fuel injector Balance/Open	Injector has been disconnected or interconnect harness open	Correct condition**
P0336	Crankshaft Angle Sensor Synchronization	Sensor or interconnect harness intermittent	Correct condition**
P0337	Crankshaft Angle Sensor Circuit/SG	Sensor or interconnect harness shorted to chassis ground	Correct condition**
P0339	Crankshaft Angle Sensor Intermittent/Erratic	Sensor or interconnect harness intermittent	Correct condition**
P0340	Camshaft Angle Sensor Synchronization	Sensor or interconnect harness intermittent	Correct condition**
P0341	Camshaft Angle Sensor Circuit/SG	Sensor or interconnect harness shorted to chassis ground	Correct condition**
P0342	Camshaft Angle Sensor Intermittent/Erratic	Sensor or interconnect harness intermittent	Correct condition**
P0480	Fan-Primary/Right Relay Control Circuit	Relay erratic or intermittent	Correct condition*
P0481	Fan-Secondary/Left Relay Control Circuit High	Relay or interconnect harness shorted to battery power	Correct condition*
P0482	Fan-Secondary/Left Relay Control Circuit Low/SG/Open	Secondary fan fuse has blown, the secondary fan relay has been removed or interconnect harness shorted to chassis ground	Correct condition*
P0483	Fan-Secondary/Left Relay Control Circuit	Relay erratic or intermittent	Correct condition*
P0484	Fan-Primary/Right Relay Control Circuit High	Relay or interconnect harness shorted to battery power	Correct condition*
P0485	Fan-Primary/Right Relay Control Circuit Low/SG/Open	Primary fan fuse has blown, the primary fan relay has been removed or interconnect harness shorted to chassis ground	Correct condition*
P0500	Vehicle Speed-Sensor	Sensor circuit signal intermittent or missing	Correct condition*, start and drive the vehicle*
P0508	IAC System Circuit Low/SG	IAC interconnect harness shorted to chassis ground	Correct condition*
P0509	IAC System Circuit High/Open	IAC disconnected or the interconnect harness shorted to battery power	Correct condition*
P0520	Engine Oil Sensor/Switch	Sensor or interconnect harness erratic or intermittent	Correct condition*
P0562	System Voltage Low	Battery charge condition low or the regulator/rectifier output low	Correct condition*
P0563	System Voltage High	Battery cable connections are loose or the regulator/rectifier output high	Correct condition*
P0601	ECM CAN Communication Shutdown	Intermittent CAN connection or unstable CAN condition caused ECM to temporarily shut down CAN communication	Correct CAN communication issue*

- Using the Pinion Gear/Shaft Removal Tool and a hammer, remove the pinion gear from the gear case housing.



XR359

- Secure the pinion gear in a bearing puller; then remove the pinion bearing using a press. Account for a collar and a bearing.

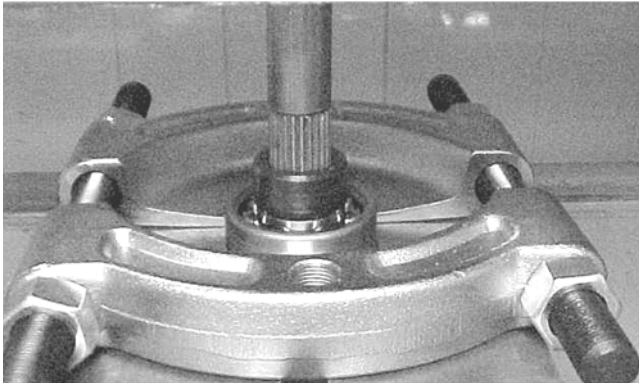

CC879

- Remove any reusable parts from the gear case housing; then discard the housing and lock collar.

Assembling Pinion Gear

- Install the bearing onto the pinion shaft. Install the pinion shaft collar.

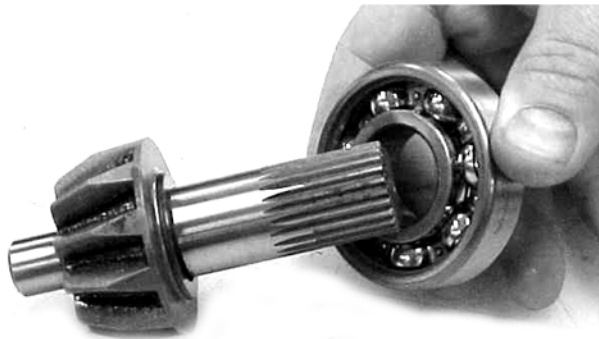

CC882

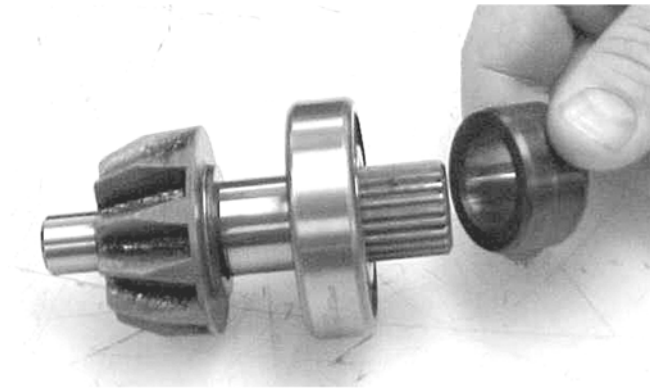

CC883

- Place the pinion assembly in a bearing puller; then install the bearing using a press.

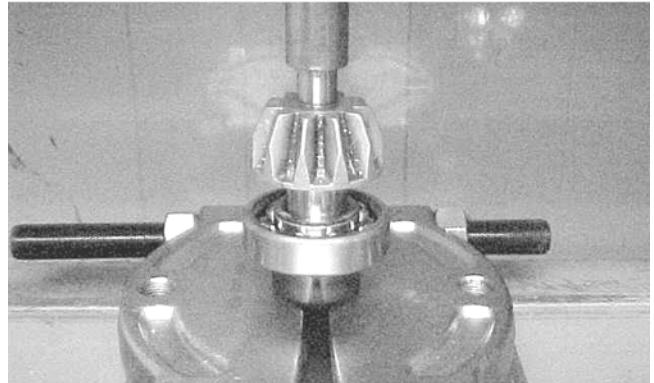

CC884

- Using a propane torch, heat the gear case housing to approximately 200° F; then install the pinion assembly.
- Install the internal snap ring with the sharp side directed away from the bearing.



WC429

INSTALLING

1. Secure the brake disc to the hub with the four cap screws (coated with blue Loctite #243). Tighten to 15 ft-lb.
2. Apply grease to the splines in the hub.
3. Install the hub assembly onto the shaft.



PR290

4. Secure the hub assembly with the hex nut. Tighten only until snug.
5. Secure the brake caliper to the knuckle with two new "patch-lock" cap screws. Tighten to 20 ft-lb.

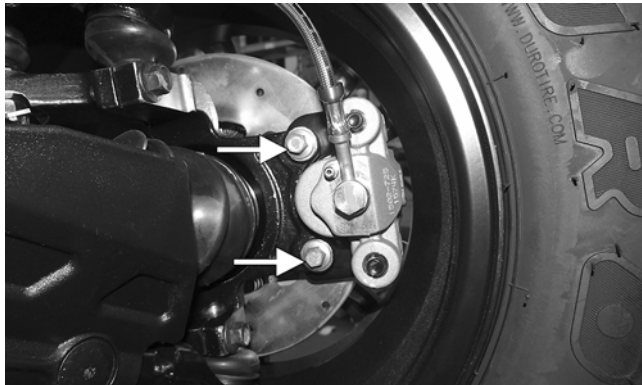

XR012A

6. Using an appropriate hub retaining wrench, tighten the hub nut (from step 4) to 200 ft-lb; then install and spread a new cotter pin making sure each side of the pin is flush to the hex nut.

■NOTE: If the cotter pin does not line up, always tighten to the next alignment.

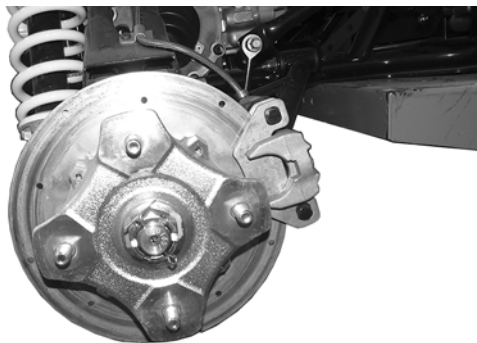

XR099

7. Install the wheel and tighten the wheel nuts in 20 ft-lb increments to a final torque of 40 ft-lb (steel wheel), 60 ft-lb (aluminum wheel w/black nuts), or 80 ft-lb (aluminum wheel w/chrome nuts).
8. Remove the ATV from the support stand.

Hand Brake Lever/Master Cylinder Assembly

■NOTE: The master cylinder is a non-serviceable component; it must be replaced as an assembly.

REMOVING

1. Slide a piece of flexible tubing over one of the wheel bleeder valves and direct the other end into a container. Remove the reservoir cover; then open the bleeder valve. Allow the brake fluid to drain completely.

■NOTE: Compressing the brake lever several times will quicken the draining process.



AF637D

2. Place an absorbent towel around the connection to absorb brake fluid. Remove the banjo-fitting from the master cylinder. Account for two crush washers and a banjo-fitting bolt.

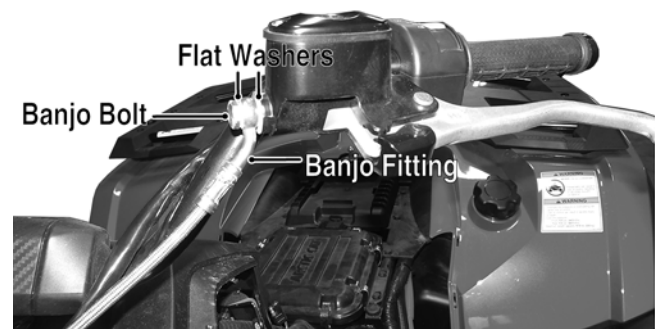

XR092A

CAUTION

Brake fluid is highly corrosive. Do not spill brake fluid on any surface of the ATV.

3. Remove the snap ring and pivot pin securing the brake lever to the master cylinder housing; then remove the brake lever and set aside.

CLICK HERE TO **DOWNLOAD** THE COMPLETE MANUAL

- Thank you very much for reading the preview of the manual.
- You can download the complete manual from: www.heydownloads.com by clicking the link below



- Please note: If there is no response to CLICKING the link, please download this PDF first and then click on it.

CLICK HERE TO **DOWNLOAD** THE COMPLETE MANUAL