A

ACC

ACC

C

SECTION ACC

ACCELERATOR CONTROL SYSTEM

CONTENTS

D

E

PRECAUTION	2	Removal and Installation	3	F
PRECAUTIONS	2	Inspection	3	
Precaution for Supplemental Restraint System (SRS) "AIR BAG" and "SEAT BELT PRE-TEN- SIONER"	2	SERVICE DATA AND SPECIFICATIONS (SDS)	5	G
REMOVAL AND INSTALLATION	3	SERVICE DATA AND SPECIFICATIONS (SDS)	5	H
ACCELERATOR PEDAL ASSEMBLY	3	Accelerator Control	5	
Exploded View	3			I

J

K

L

M

N

O

P

CLICK HERE TO **DOWNLOAD** THE COMPLETE MANUAL

- Thank you very much for reading the preview of the manual.
- You can download the complete manual from: www.heydownloads.com by clicking the link below



- Please note: If there is no response to CLICKING the link, please download this PDF first and then click on it.

CLICK HERE TO **DOWNLOAD** THE COMPLETE MANUAL

BCM

< ECU DIAGNOSIS INFORMATION >

[WITH INTELLIGENT KEY SYSTEM]

Monitor Item	Condition	Value/Status	
HI BEAM SW	High beam switch OFF	Off	A
	High beam switch HI	On	
ID OK FLAG	Ignition switch ON	Reset	B
	Ignition switch OFF	Set	
IGN REQ -IPDM	Ignition switch OFF	Off	C
	Ignition switch ON	On	
IGN RLY1 F/B	Ignition switch OFF	Off	D
	Ignition switch ON	On	
INT VOLUME	Wiper intermittent dial is in a dial position 1 - 7	1 - 7	
IS STATUS -ECM	IS status OFF	Off	E
	IS status ON	On	
I-KEY OK FLAG	I-Key OFF	Key OFF	F
	I-Key ON	Key ON	
KEY CYL LK-SW	Door key cylinder LOCK position	Off	G
	Door key cylinder other than LOCK position	On	
KEY CYL UN-SW	Door key cylinder UNLOCK position	Off	H
	Door key cylinder other than UNLOCK position	On	
KEY CYL SW-TR	Back door key cylinder UNLOCK position	Off	I
	Back door key cylinder other than UNLOCK position	On	
LIGHT OFF SW	Headlamp switch ON	Off	J
	Headlamp switch OFF	On	
NEUTRAL SW-IPDM	Selector lever N (Neutral) position	Off	K
	Selector lever any position except N (Neutral)	On	
OPTI SEN (DTCT)	Bright outside of the vehicle	Close to 5V	L
	Dark outside of the vehicle	Close to 0V	
OPTI SEN (FILT)	Bright outside of the vehicle	Close to 5V	
	Dark outside of the vehicle	Close to 0V	
OPTICAL SENSOR	Optical sensor OFF	Off	
	Optical sensor ON	On	
PASSING SW	Other than lighting switch PASS	Off	
	Lighting switch PASS	On	BCS
PRBT ENG STRT	When the engine start is prohibited	Reset	
	When the engine start is permitted	Set	
PRMT ENG STRT	When the engine start is prohibited	Reset	N
	When the engine start is permitted	Set	
PRMT RKE STRT	When the engine start is prohibited	Reset	O
	When the engine start is permitted	Set	
PUSH SW	Return ignition switch to LOCK position	Off	
	Press ignition switch	On	P
PUSH SW-IPDM	When engine switch (push switch) is not pressed	Off	
	When engine switch (push switch) is pressed	On	
REAR DEF SW	Rear window defogger switch OFF	Off	
	Rear window defogger switch ON	On	

U1010 CONTROL UNIT (CAN)

< DTC/CIRCUIT DIAGNOSIS >

[WITH INTELLIGENT KEY SYSTEM]

U1010 CONTROL UNIT (CAN)

DTC Logic

INFOID:000000012422499

DTC DETECTION LOGIC

CONSULT Display	DTC Detection Condition	Possible Cause
CAN COMM CIRCUIT [U1010]	BCM detected internal CAN communication circuit malfunction.	BCM

Diagnosis Procedure

INFOID:000000012422500

1. REPLACE BCM

When DTC U1010 is detected, replace BCM.

>> Replace BCM. Refer to [BCS-76. "Removal and Installation"](#).

BCM

< ECU DIAGNOSIS INFORMATION >

[WITHOUT INTELLIGENT KEY SYSTEM]

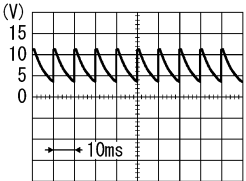
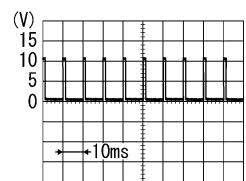
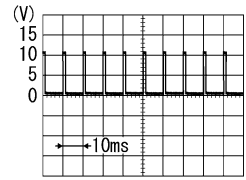
Terminal No. (Wire color)		Description		Condition		Value (Approx.)
		Signal name	Input/ Output			
(+)	(-)					
12 (W)	Ground	Auto light power supply 5V	Output	Ignition switch	OFF	0V
					ON	5V
16 (P)	Ground	Audio dongle	Input/ Output	Ignition switch	OFF	5V
17 (L)	Ground	CVT shift selector park position switch power	Output	Selector lever	P position	0V
					Except P position	Battery voltage
19 (LG)	Ground	Auto light signal	Input	Ignition switch ON	Outside of vehicle is bright	Close to 5V
					Outside of vehicle is dark	Close to 0V
23 (G)	Ground	Power window relay control	Output	Ignition switch	OFF	Battery voltage
					ON	0V
24 (LA/R)	Ground	Rear window defogger relay control	Output	Rear window defogger	Not activated	Battery voltage
					Activated	0V
25 (BR)	Ground	Accessory relay-1 control	Output	Ignition switch	OFF	Battery voltage
					ON	0V
27 (Y)	Ground	Ignition relay-1 control	Output	Ignition switch	OFF	Battery voltage
					ON	0V
28 (LA/W)	Ground	Front blower motor relay control	Output	Ignition switch	OFF	Battery voltage
					ON	0V
30 (V)	Ground	Auto light reference ground	Output	Ignition switch	ON	0V
33 (LG)	Ground	Combination switch output 5	Output	Combination switch (Wiper intermittent dial 1)	OFF	 <p style="text-align: center;">PKIB4960J 7.0 – 8.0V</p>
					INT VOLUME 2	 <p style="text-align: center;">PKIB4958J 1.2V</p>
					INT VOLUME 3	
					RR WIPER INT	
RR WIPER ON						
34 (Y)	Ground	Combination switch input 5	Input	Combination switch (Wiper intermittent dial 1)	OFF	 <p style="text-align: center;">PKIB4958J 1.0V</p>
					TAIL LAMP	
					TURN RH	
					NO LIGHT	

A
B
C
D
E
F
G
H
I
J
K
L
N
O
P

BCS

NORMAL OPERATING CONDITION

< SYMPTOM DIAGNOSIS >

[WITHOUT INTELLIGENT KEY SYSTEM]

NORMAL OPERATING CONDITION

Description

INFOID:000000012422565

SHIPPING MODE

- Shipping mode inhibits battery power consumption during transportation or storage of the vehicle. Vehicle is set to shipping mode before being shipped from the factory.
- When ignition switch is OFF, BCM operates shipping mode.
- BCM control function is limited in shipping mode. Remote keyless entry function is not operated during the shipping mode.
- For shipping mode cancel operation, refer to [BCS-125. "Work Procedure"](#).

NOTE:

Do not cancel shipping mode during storage of the vehicle. Always cancel shipping mode before delivery of the vehicle to customer.

FRONT DISC BRAKE

< REMOVAL AND INSTALLATION >

FRONT DISC BRAKE BRAKE PAD (1 PISTON TYPE)

BRAKE PAD (1 PISTON TYPE) : Exploded View

INFOID:000000012427204

USA Production

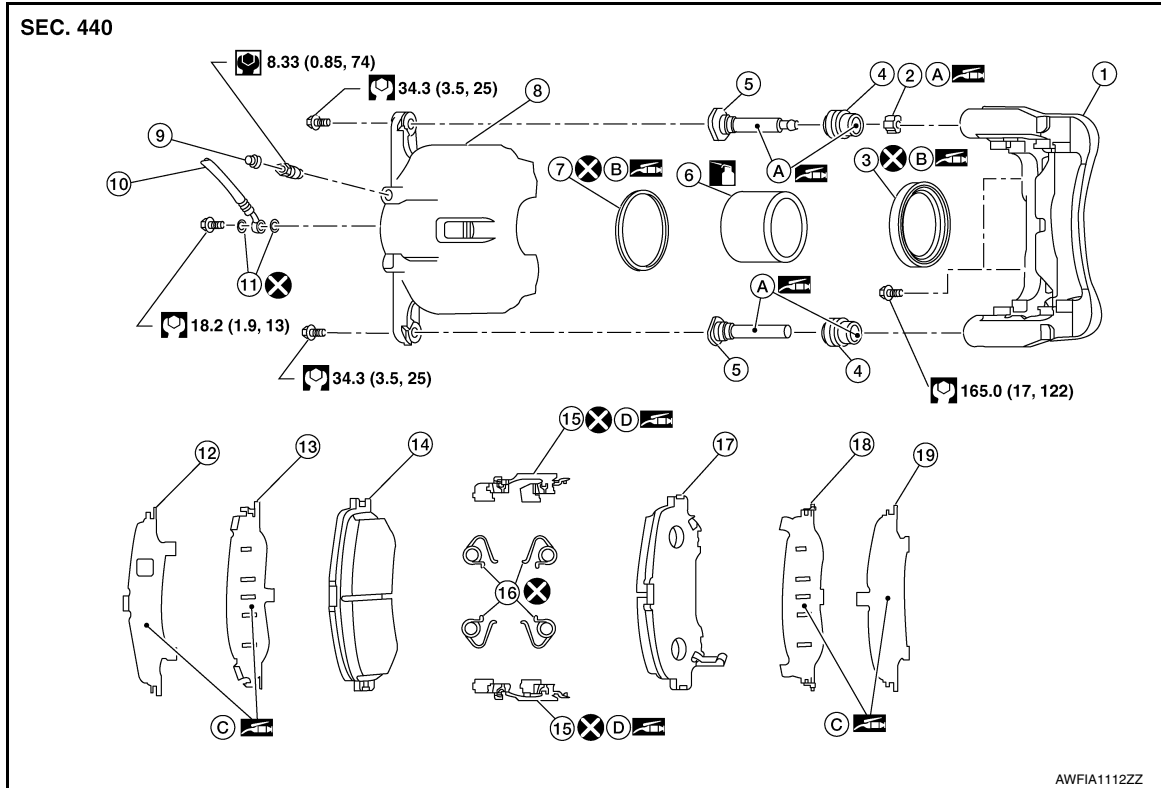

- | | | |
|----------------------|----------------------------|----------------------|
| 1. Torque member | 2. Bushing | 3. Piston boot |
| 4. Slide pin boot | 5. Slide pin | 6. Piston |
| 7. Piston seal | 8. Brake caliper body | 9. Bleeder cap |
| 10. Brake hose | 11. Copper sealing washers | 12. Inner shim cover |
| 13. Inner shim | 14. Inner pad | 15. Pad retainer |
| 16. Anti-rattle clip | 17. Outer pad | 18. Outer shim |
| 19. Outer shim cover | A. Niglube Rx-2 | B. Rubber grease |
| C. Molykote® AS-880N | D. Molykote® 7439 | |

: Apply brake fluid.

COMPONENT PARTS

< SYSTEM DESCRIPTION >

[VDC/TCS/ABS]

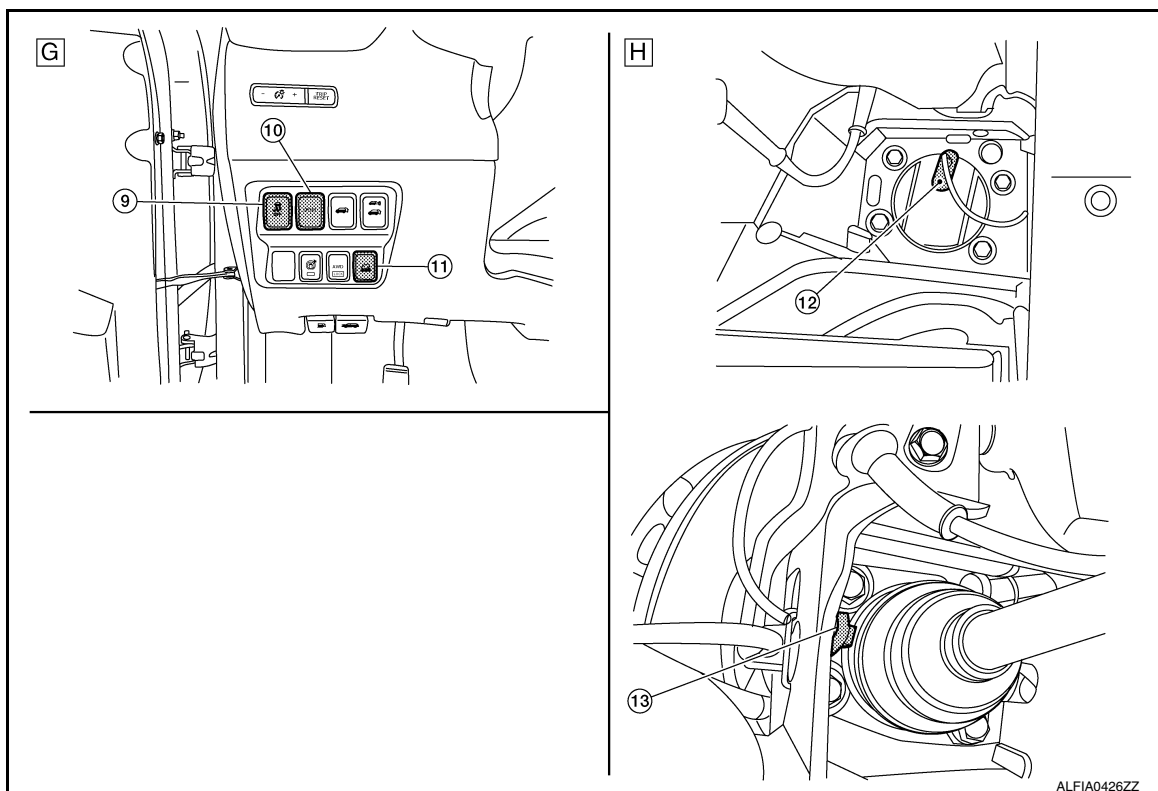

- | | | |
|---|---|----------------------------------|
| A. Steering column (view with steering wheel removed) | B. RH side of instrument panel (view with instrument panel removed) | C. LH side of engine compartment |
| D. RH side of engine compartment | E. Left front wheel area | F. Brake pedal area |
| G. Left side of instrument panel | H. Left rear wheel area | |

No.	Component parts	Function
1.	Steering angle sensor	BRC-12, "Steering Angle Sensor"
2.	Chassis control module	Mainly transmits the following signals to ABS actuator and electric unit (control unit) via CAN communication: <ul style="list-style-type: none"> • Drive mode signal • Active Trace Control signal • Brake hold status signal • Brake hold request signal Refer to DAS-131, "Component Parts Location" for detailed installation location.
3.	Brake fluid level switch	BRC-12, "Brake Fluid Level Switch"
4.	Vacuum sensor	BRC-13, "Vacuum Sensor"
5.	ABS actuator and electric unit (control unit)	BRC-11, "ABS Actuator and Electric Unit (Control Unit)"
6.	Front LH wheel sensor	BRC-11, "Wheel Sensor and Sensor Rotor"
7.	Parking brake switch	BRC-13, "Parking Brake Switch"
8.	Stop lamp switch	BRC-13, "Parking Brake Switch"
9.	VDC OFF switch	BRC-13, "VDC OFF Switch"
10.	Drive mode switch	DMS-6, "SPORT Mode Switch"
11.	Hill descent switch	BRC-13, "Hill Descent Control Switch"
12.	Rear wheel sensor LH (FWD models)	BRC-11, "Wheel Sensor and Sensor Rotor"
13.	Rear wheel sensor LH (AWD models)	BRC-11, "Wheel Sensor and Sensor Rotor"

DIAGNOSIS SYSTEM [ABS ACTUATOR AND ELECTRIC UNIT (CONTROL UNIT)]

< SYSTEM DESCRIPTION >

[VDC/TCS/ABS]

DIAGNOSIS SYSTEM [ABS ACTUATOR AND ELECTRIC UNIT (CONTROL UNIT)]

CONSULT Function

INFOID:000000012427272

APPLICATION ITEMS

CONSULT can display each diagnostic item using the diagnostic test modes as follows.

Mode	Function description
ECU identification	Parts number of ABS actuator and electric unit (control unit) can be read.
Self Diagnostic Result	"Self Diagnostic Result" and freeze frame data can be read and erased quickly.*
Data Monitor	Input/Output data in the ABS actuator and electric unit (control unit) can be read.
ACTIVE TEST	Diagnostic Test Mode in which CONSULT drives some actuators apart from the ABS actuator and electric unit (control unit) and also shifts some parameters in a specified range.
Work support	Components can be quickly and accurately adjusted.
Re/programming, Configuration	<ul style="list-style-type: none">• Read and save the vehicle specification (TYPE ID).• Write the vehicle specification (TYPE ID) when replacing ABS actuator and electric unit (control unit).

*: The following diagnosis information is erased by erasing.

- DTC
- Freeze frame data (FFD)

ECU IDENTIFICATION

ABS actuator and electric unit (control unit) part number can be read.

SELF DIAGNOSTIC RESULT

Refer to [BRC-57, "DTC Index"](#).

When "CRNT" is displayed on "Self Diagnostic Result",

- The system is presently malfunctioning.

When "PAST" is displayed on "Self Diagnostic Result",

- System malfunction in the past is detected, but the system is presently normal.

Freeze frame data (FFD)

The following vehicle status is recorded when DTC is detected and is displayed on CONSULT.

Item name	Display item
IGN counter (0 – 39)	<p>The number of times that ignition switch is turned ON after the DTC is detected is displayed.</p> <ul style="list-style-type: none">• When "0" is displayed: It indicates that the system is presently malfunctioning.• When except "0" is displayed: It indicates that system malfunction in the past is detected, but the system is presently normal. <p>NOTE: Each time when ignition switch is turned OFF to ON, numerical number increases in 1 → 2 → 3...38 → 39. When the operation number of times exceeds 39, the number do not increase and "39" is displayed until self-diagnosis is erased.</p>

ACTIVE TEST

The active test is used to determine and identify details of a malfunction, based on self-diagnosis test results and data obtained in the DATA MONITOR. In response to instructions from CONSULT, instead of those from ABS actuator and electric unit (control unit) on the vehicle, a drive signal is sent to the actuator to check its operation.

CAUTION:

- **Never perform ACTIVE TEST while driving the vehicle.**
- **Always bleed air from brake system before active test.**
- **Never perform active test when system is malfunctioning.**

NOTE:

- When active test is performed while depressing the pedal, the pedal depressing stroke may change. This is not a malfunction.
- "TEST IS STOPPED" is displayed approx. 10 seconds after operation start.

C1101, C1102, C1103, C1104 WHEEL SENSOR

[VDC/TCS/ABS]

< DTC/CIRCUIT DIAGNOSIS >

5. Stop the vehicle.
6. Turn the ignition switch OFF.
NOTE:
Wait at least 10 seconds after turning ignition switch OFF.
7. Start the engine.
NOTE:
Wait at least 10 seconds after starting the engine.
8. Perform "Self Diagnostic Result" mode of "ABS".

Is DTC "C1101", "C1102", "C1103" or "C1104" detected?

- YES >> GO TO 5.
NO >> Inspection End.

5.CHECK ABS ACTUATOR AND ELECTRIC UNIT (CONTROL UNIT) POWER SUPPLY AND GROUND CIRCUIT

Check the ABS actuator and electric unit (control unit) power supply and ground circuits. Refer to [BRC-158](#), "Diagnosis Procedure".

Is the inspection result normal?

- YES >> GO TO 6.
NO >> Repair / replace harness, connector, fuse, or fusible link.

6.CHECK TERMINAL

1. Turn the ignition switch OFF.
2. Disconnect ABS actuator and electric unit (control unit) harness connector and then check the ABS actuator and electric unit (control unit) pin terminals for damage or loose connection with harness connector.
3. Disconnect wheel sensor harness connector and check each wheel sensor pin terminal for damage or loose connection with harness connector.

Is the inspection result normal?

- YES >> GO TO 8.
NO >> Repair / replace harness, connector, or terminal, and GO TO 7.

7.PERFORM SELF-DIAGNOSIS (2)

CONSULT

1. Connect ABS actuator and electric unit (control unit) harness connector.
2. Connect wheel sensor harness connector.
3. Erase "Self Diagnostic Result" mode of "ABS".
4. Turn the ignition switch OFF → ON → OFF.
NOTE:
Wait at least 10 seconds after turning ignition switch OFF or ON.
5. Start the engine.
6. Drive the vehicle at approx. 50 km/h (31 MPH) or more for approx. 2 minutes.
NOTE:
Vehicle must be driven after repair or replacement to erase the previous DTCs.
7. Stop the vehicle.
8. Turn the ignition switch OFF.
NOTE:
Wait at least 10 seconds after turning ignition switch OFF.
9. Start the engine.
NOTE:
Wait at least 10 seconds after starting the engine.
10. Perform "Self Diagnostic Result" mode of "ABS".

Is DTC "C1101", "C1102", "C1103" or "C1104" detected?

- YES >> GO TO 8.
NO >> Inspection End.

8.CHECK WHEEL SENSOR HARNESS

1. Turn the ignition switch OFF.
2. Disconnect ABS actuator and electric unit (control unit) harness connector.
3. Disconnect wheel sensor harness connector.

C1130 ENGINE SIGNAL

[VDC/TCS/ABS]

< DTC/CIRCUIT DIAGNOSIS >

2. CHECK ABS ACTUATOR AND ELECTRIC UNIT (CONTROL UNIT) POWER SUPPLY AND GROUND CIRCUIT

Check the ABS actuator and electric unit (control unit) power supply and ground circuits. Refer to [BRC-158](#), "[Diagnosis Procedure](#)".

Is the inspection result normal?

YES >> GO TO 3.

NO >> Repair / replace harness, connector, fuse, or fusible link.

3. CHECK CONNECTOR AND TERMINAL

1. Turn the ignition switch OFF.
2. Disconnect ECM harness connector.
3. Disconnect ABS actuator and electric unit (control unit) harness connector.
4. Check the connector for disconnection or looseness.
5. Check the pin terminals for damage or loose connection with harness connector.

Is the inspection result normal?

YES >> GO TO 4.

NO >> Repair / replace harness, connector, or terminal, securely lock the connector, and GO TO 4.

4. CHECK ABS ACTUATOR AND ELECTRIC UNIT (CONTROL UNIT)

Ⓜ CONSULT

1. Connect ECM harness connector.
2. Connect ABS actuator and electric unit (control unit) harness connector.
3. Erase "Self Diagnostic Result" of "ABS"
4. Turn the ignition switch OFF.

NOTE:

Wait at least 10 seconds after turning ignition switch OFF.

5. Start the engine.

NOTE:

Wait at least 10 seconds after starting the engine.

6. Perform "Self Diagnostic Result" mode of "ABS".

Is DTC "C1130" or "U1000" detected?

YES ("C1130")>>GO TO 1.

YES ("U1000")>>Refer to [LAN-20](#), "[Trouble Diagnosis Flow Chart](#)".

NO >> Inspection End.

A
B
C
D
E
G
H
I
J
K
L
M
N
O
P

BRC

C119A VACUUM SENSOR

< DTC/CIRCUIT DIAGNOSIS >

[VDC/TCS/ABS]

2. CHECK VACUUM SENSOR POWER SUPPLY

1. Turn the ignition switch OFF.
2. Disconnect vacuum sensor harness connector.
3. Check the voltage between vacuum sensor harness connector and ground.

Vacuum sensor		—	Voltage (Approx.)
Connector	Terminal		
E167	5	Ground	0 V

4. Turn the ignition switch ON.
NOTE:
Start the engine.
5. Check the voltage between vacuum sensor harness connector and ground.

Vacuum sensor		—	Voltage (Approx.)
Connector	Terminal		
E167	3	Ground	5 V

Is the inspection result normal?

- YES >> GO TO 4.
NO >> GO TO 3.

3. CHECK VACUUM SENSOR POWER SUPPLY CIRCUIT

1. Turn the ignition switch OFF.
2. Disconnect ABS actuator and electric unit (control unit) harness connector.
3. Check the continuity between vacuum sensor harness connector and ABS actuator and electric unit (control unit) harness connector.

Vacuum sensor		ABS actuator and electric unit (control unit)		Continuity
Connector	Terminal	Connector	Terminal	
E167	3	E125	5	Yes

4. Check the continuity between vacuum sensor harness connector and ground.

Vacuum sensor		—	Continuity
Connector	Terminal		
E167	3	Ground	No

Is the inspection result normal?

- YES >> GO TO 4.
NO >> Repair / replace harness or connector.

4. CHECK VACUUM SENSOR GROUND CIRCUIT

1. Turn the ignition switch OFF.
2. Check the continuity between vacuum sensor harness connector and ground.

Vacuum sensor		—	Continuity
Connector	Terminal		
E167	2	Ground	No

Is the inspection result normal?

- YES >> GO TO 5.
NO >> Repair / replace harness or connector.

5. CHECK ABS ACTUATOR AND ELECTRIC UNIT (CONTROL UNIT) POWER SUPPLY AND GROUND CIRCUIT

ABS ACTUATOR AND ELECTRIC UNIT (CONTROL UNIT)

< REMOVAL AND INSTALLATION >

[VDC/TCS/ABS]

ABS ACTUATOR AND ELECTRIC UNIT (CONTROL UNIT)

Exploded View

INFOID:000000012427386

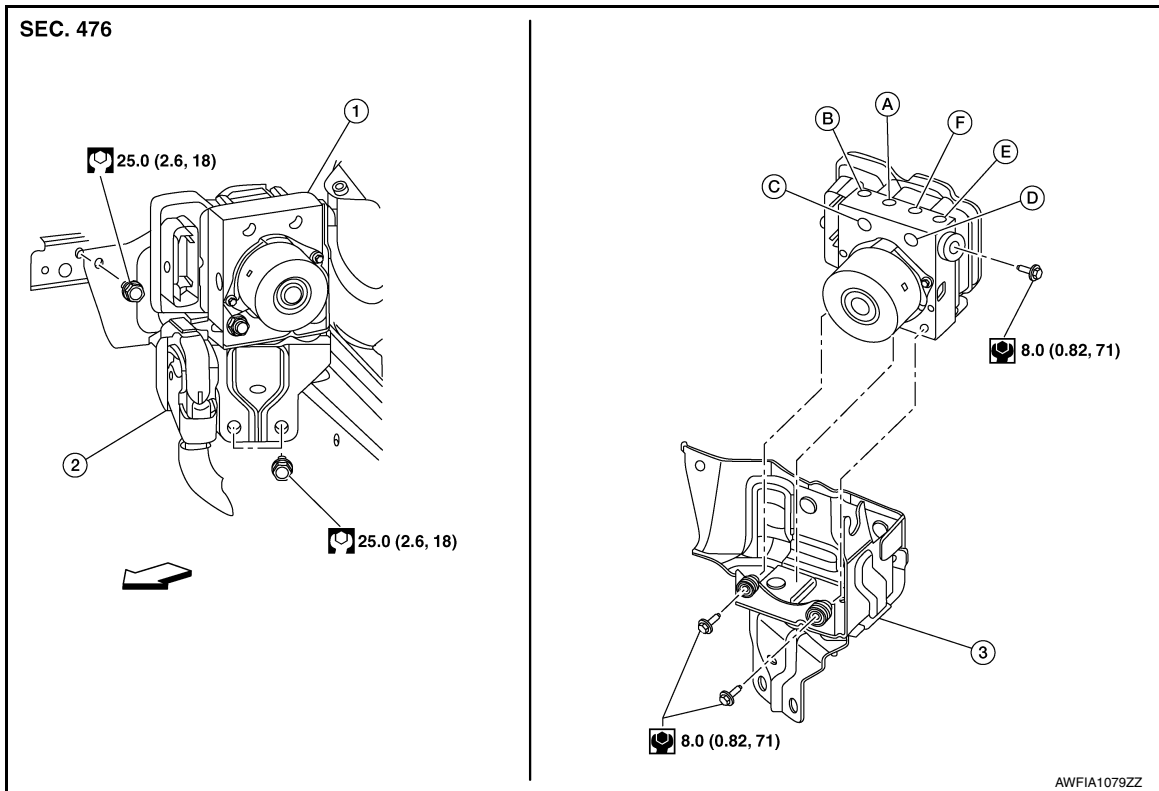

A

B

C

D

E

BRC

G

H

I

J

K

L

M

N

O

P

- | | | |
|--|-----------------------------|--|
| 1. ABS actuator and electric unit (control unit) | 2. Connector | 3. Bracket |
| A. To front LH brake caliper | B. To rear RH brake caliper | C. From master cylinder secondary side |
| D. From master cylinder primary side | E. To rear LH brake caliper | F. To front RH brake caliper |

↶ Front

Removal and Installation

INFOID:000000012427387

REMOVAL

CAUTION:

- To remove brake tube, use a flare nut wrench to prevent flare nuts and brake tube from being damaged.
- Do not remove actuator by holding harness.

NOTE:

- Before replacing ABS actuator and electric unit (control unit), perform "Before Replace ECU" of "Read / Write Configuration" to save or print current vehicle specification. Refer to [BRC-76, "Work Procedure"](#).
 - When removing components such as hoses, tubes/lines, etc., cap or plug openings to prevent fluid from spilling.
1. Disconnect negative battery terminal. Refer to [PG-82, "Exploded View"](#).
 2. Remove the cowl top cover and cowl top extension. Refer to [EXT-26, "Removal and Installation"](#).
 3. Separate brake tubes from ABS actuator and electric unit (control unit). Refer to [BR-21, "FRONT : Exploded View"](#).
 4. Remove the brake booster vacuum hose. Refer to [BR-32, "Removal and Installation"](#).
 5. Separate the brake booster vacuum tube and place aside. Refer to [BR-22, "FRONT : Removal and Installation"](#).
 6. Disconnect the harness connector from the ABS actuator and electric unit (control unit).
 7. Remove ABS actuator and electric unit (control unit) bracket bolts and bushings.

DISTANCE SENSOR ALIGNMENT

[FORWARD EMERGENCY BRAKING]

< BASIC INSPECTION >

- Distance sensor target board (1).

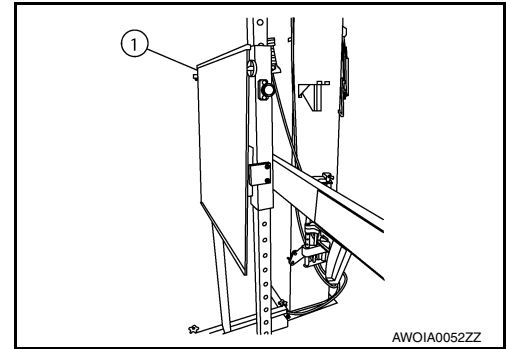

- Hunter self-centering wheel adapter (1) [shown with laser assembly (2) installed] (Hunter alignment rack head may be substituted).

NOTE:

Dealers that are not equipped with a Hunter self-centering wheel adapter will require the following kit:
Part No. 1-20-2722-1-IF (kit SCA W/Tire Clamp-Distance Sensor Aiming)

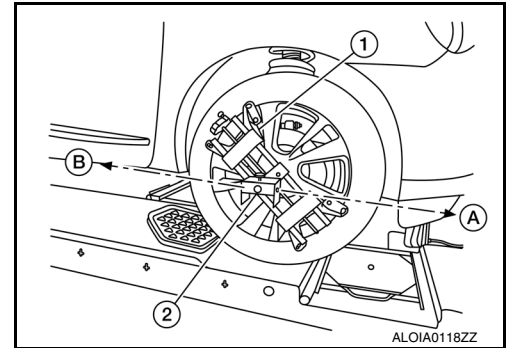

- Laser assembly (with bi-directional laser beam) as shown in the illustration.

- Tightening knob (1)
- Power ON/OFF button (2)
- Front laser beam opening (3)
- Rear laser beam opening (4)
- Attaching shaft (5)

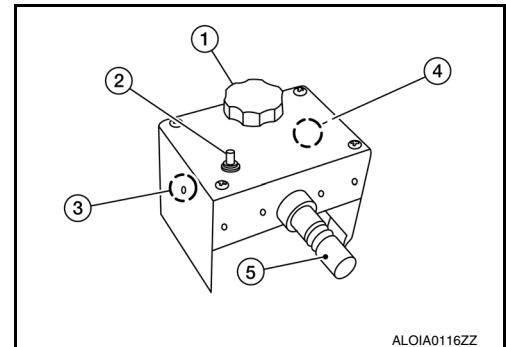

- Stationary target as shown in the illustration.

- Stationary target (1)
- Laser signal reception plate (2)

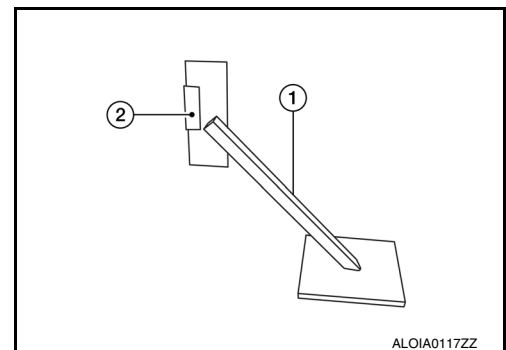

- Distance chain (not shown).

Preparation

INFOID:000000012797902

1. ADVANCE PREPARATION FOR RADAR ALIGNMENT PROCEDURE

1. Adjust all tire pressures to the specified value.
2. Empty the vehicle. (Remove any luggage from the passenger compartment, luggage room, etc.)
3. Shift the selector lever to "P" position, and release the parking brake.
4. Fully fill the fuel tank, and then check that the coolant and oils are filled up to correct level.
5. Clean off the right front side of the fascia in front of the Distance sensor.

U0428 STRG SEN CAN 2

< DTC/CIRCUIT DIAGNOSIS >

[FORWARD EMERGENCY BRAKING]

U0428 STRG SEN CAN 2

DTC Logic

INFOID:000000012788366

DTC DETECTION LOGIC

DTC	Trouble diagnosis name	DTC detecting condition
U0428	STRG SEN CAN CIR2 (Steering sensor CAN circuit2)	If distance sensor detects an error signal that is received from steering angle sensor via CAN communication

POSSIBLE CAUSE

Steering angle sensor

FAIL-SAFE

FEB system is canceled.

DTC CONFIRMATION PROCEDURE

1.CHECK DTC PRIORITY

If DTC "U0428" is displayed with DTC "U1000", first diagnose the DTC "U1000".

Is applicable DTC detected?

- YES >> Perform diagnosis of applicable. Refer to [BRC-256, "DTC Logic"](#).
- NO >> GO TO 2.

2.PERFORM DTC CONFIRMATION PROCEDURE

1. Start the engine.
2. Turn the FEB system ON.
3. Perform "All DTC Reading" with CONSULT.
4. Check if the "U0428" is detected as the current malfunction in "Self Diagnostic Result" mode of "LASER/RADAR".

Is "U0428" detected as the current malfunction?

- YES >> Refer to [BRC-255, "Diagnosis Procedure"](#).
- NO-1 >> To check malfunction symptom before repair: Refer to [GI-45, "Intermittent Incident"](#).
- NO-2 >> Confirmation after repair: Inspection End.

Diagnosis Procedure

INFOID:000000012788367

1.CHECK DTC PRIORITY

If DTC "U0428" is displayed with DTC "U1000", first diagnose the DTC "U1000".

Is applicable DTC detected?

- YES >> Perform diagnosis of applicable. Refer to [BRC-256, "DTC Logic"](#).
- NO >> GO TO 2.

2.CHECK ABS ACTUATOR AND ELECTRIC UNIT (CONTROL UNIT) SELF-DIAGNOSIS RESULTS

Check if any DTC is detected in "Self Diagnostic Result" mode of "ABS".

Is any DTC detected?

- YES >> Perform diagnosis on the detected DTC and repair or replace the malfunctioning parts. Refer to [BRC-57, "DTC Index"](#).
- NO >> Replace the distance sensor. Refer to [DAS-122, "Removal and Installation"](#).

REPLACEMENT OPERATIONS

< REMOVAL AND INSTALLATION >





REPLACEMENT OPERATIONS

Description

INFOID:000000012424337

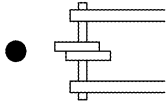
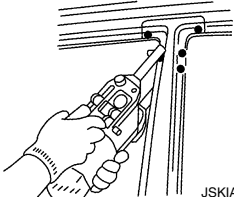
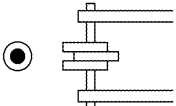
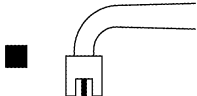
- This section is prepared for technicians who have attained a high level of skill and experience in repairing collision-damaged vehicles and also use modern service tools and equipment. Persons unfamiliar with body repair techniques should not attempt to repair collision-damaged vehicles by using this section.
- Technicians are also encouraged to read Body Repair Manual (Fundamentals) in order to ensure that the original functions and quality of the vehicle can be maintained. The Body Repair Manual (Fundamentals) contains additional information, including cautions and warning, that are not including in this manual. Technicians should refer to both manuals to ensure proper repairs.
- Please note that these information are prepared for worldwide usage, and as such, certain procedures might not apply in some regions or countries.

The symbols used in this section for welding operations are shown below.

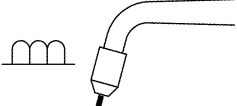
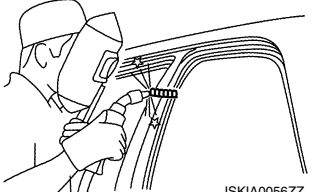
Symbol marks	Description	
 <p data-bbox="402 844 490 861">JSKIA0049ZZ</p>	2-spot welds	 <p data-bbox="1291 970 1377 987">JSKIA0053ZZ</p>
 <p data-bbox="402 1096 490 1113">JSKIA0050ZZ</p>	3-spot welds	
 <p data-bbox="402 1474 490 1491">JSKIA0051ZZ</p>	MIG plug weld	 <p data-bbox="1291 1348 1377 1365">JSKIA0054ZZ</p> <p data-bbox="1006 1381 1323 1407">For 3 panels plug weld method</p> <div style="display: flex; flex-direction: column; align-items: center;"> <div data-bbox="1144 1438 1307 1480"> <p data-bbox="1144 1449 1177 1470">■ A</p>  </div> <div data-bbox="1144 1533 1307 1575"> <p data-bbox="1144 1543 1177 1564">■ B</p>  </div> </div> <p data-bbox="1291 1600 1377 1617">JSKIA0055ZZ</p>
 <p data-bbox="402 1852 490 1869">JSKIA0052ZZ</p>	MIG seam weld / Point weld	 <p data-bbox="1291 1852 1377 1869">JSKIA0056ZZ</p>

PREPARATION

< PREPARATION >

PREPARATION

PREPARATION

Special Service Tools

INFOID:0000000012422859

The actual shape of the tools may differ from those illustrated here.

Tool number (TechMate No.) Tool name	Description
— (165-GR8-1200KIT-NI) Nissan battery and electronics tester	Testing batteries, starting and charging systems and charges batteries. For operating instructions, refer to diagnostic station instruction manual.
— (165-EXP-800 NI) Midtronic hand-held battery tester	Testing batteries and charging systems. For operating instructions, refer to diagnostic analyzer instruction manual.

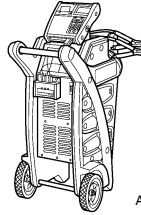

AWIIA1239ZZ

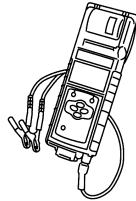

JSMIA0806ZZ

Commercial Service Tools

INFOID:0000000012422860

Tool name	Description
Power tool	Loosening bolts, nuts and screws



PIIB1407E

A
B
C
D
E
F
G
H
I
J
K
L

CHG

COOLING FAN

< REMOVAL AND INSTALLATION >

5. Remove fender protector side cover. Refer to [EXT-29, "FENDER PROTECTOR : Exploded View"](#).
 6. Remove air duct (inlet). Refer to [EM-26, "Exploded View"](#).
 7. Remove radiator core support (upper). Refer to [DLK-248, "Removal and Installation"](#) (WITH INTELLIGENT KEY SYSTEM), [DLK-367, "Removal and Installation"](#) (WITHOUT INTELLIGENT KEY SYSTEM).
 8. Remove radiator hose (upper) from radiator.
- CAUTION:**
Do not spill engine coolant on the drive belt.
9. Disconnect harness connector from cooling fan controller.
 10. Remove harness retainers from fan shroud.
 11. Remove CVT cooler hose retainers from fan shroud.
 12. Remove reservoir tank hose from fan shroud. Refer to [CO-13, "Exploded View"](#).
 13. Remove cooling fan assembly. Refer to [CO-17, "Exploded View"](#).

CAUTION:

Be careful not to damage the radiator.

INSTALLATION

Installation is in the reverse order of removal.

- Reset electronic systems as necessary. Refer to [PG-74, "ADDITIONAL SERVICE WHEN REMOVING BATTERY NEGATIVE TERMINAL : Special Repair Requirement"](#)

CAUTION:

- **To prevent damage to the parts, connect the battery to the positive terminal first.**
- **After connecting the positive and negative terminal to securely supply battery voltage, ensure that the positive and negative terminal are tightly clamped to battery and negative posts for good contact.**
- **To securely supply battery voltage, check the positive and negative terminals for poor connection caused by corrosion.**
- After installation, refill coolant and check for leaks. Refer to [CO-9, "Refilling"](#) and [CO-8, "Inspection"](#).

CAUTION:

Do not spill coolant in engine compartment. Use a shop cloth to absorb coolant.

NOTE:

Cooling fan is controlled by ECM. For details, refer to [EC-66, "On Board Diagnosis Function"](#).

Disassembly and Assembly

INFOID:000000012429228

DISASSEMBLY

1. Remove cooling fan nuts, and then remove the cooling fans (RH and LH).
2. Remove fan motor cover and fan motors (RH and LH).

ASSEMBLY

Assembly is in the reverse order of disassembly.

CAUTION:

Apply high thread locking sealant to cooling fan motor shaft.

Inspection

INFOID:000000012429229

INSPECTION AFTER DISASSEMBLY

Cooling Fan

Inspect cooling fan for cracks or unusual bends.

- If anything is found, replace cooling fan.

DIAGNOSIS SYSTEM (SIDE RADAR RH)

< SYSTEM DESCRIPTION >

[DRIVER ASSISTANCE SYSTEM]

DIAGNOSIS SYSTEM (SIDE RADAR RH)

CONSULT Function (SIDE RADAR RIGHT)

INFOID:000000012731456

DESCRIPTION

CONSULT performs the following functions by communicating with the side radar RH.

Diagnosis mode	Function
Self Diagnostic Result	Displays memorized DTC in the side radar.
Data Monitor	Displays real-time data of side radar.
Active Test	Enables operation check of electrical loads by sending driving signal to them.
ECU Identification	Displays part number of side radar.

SELF DIAGNOSTIC RESULT

Self Diagnostic Result

Displays memorized DTC in side radar RH. Refer to [DAS-37. "DTC Index"](#).

FFD (Freeze Frame Data)

The side radar records the following data when the malfunction is detected.

Freeze Frame Data item	Description
VHCL SP from ADAS	The vehicle speed (from ADAS control unit) at the moment a malfunction is detected is displayed.
TURN SIG STATUS	Turn signal status at the moment a malfunction is detected is displayed.

DATA MONITOR

NOTE:

The following table includes information (items) inapplicable to this vehicle. For information (items) applicable to this vehicle, refer to CONSULT display items.

Monitored item [Unit]	Description
BSW/CTA WARN STATUS [On/Off]	Indicates [On/Off] status of vehicle detection
BSW STATUS [On/Off]	Indicates [On/Off] status of Blind Spot Warning system
VHCL SPD SE [mph]	Indicates vehicle speed [mph]
TURN SIGNAL [LH/RH/Off]	Indicates the [LH/RH/OFF] operation of the turn signal
SHIFT POSITION [P/R/N/D]	Indicates position of transmission range switch
LUMINANCE (LEFT) [Hi/Lo]	Indicates the left side luminance level of the radar
LUMINANCE (RIGHT) [Hi/Lo]	Indicates the right side luminance level of the radar

ACTIVE TEST

CAUTION:

- **Never perform the active test while driving.**
- **Active test cannot be started while the BSW indicator is illuminated.**

Active test item	Operation	Description
BSW/BSI INDICATOR DRIVE	On	Outputs the voltage to illuminate the BSW indicator
	Off	Stops the voltage to illuminate the BSW indicator

ADDITIONAL SERVICE WHEN REPLACING DISTANCE SENSOR

< BASIC INSPECTION >

[DRIVER ASSISTANCE SYSTEM]

ADDITIONAL SERVICE WHEN REPLACING DISTANCE SENSOR

Description

INFOID:0000000012815298

Always perform the following after removing and installing or replacing the distance sensor:

1. Distance sensor initial vertical alignment
2. Distance sensor alignment

Refer to [DAS-63, "Work Procedure"](#).

CAUTION:

The system does not operate normally unless the distance sensor is aligned properly.

Work Procedure

INFOID:0000000012815299

1. DISTANCE SENSOR INITIAL VERTICAL ALIGNMENT

Perform the distance sensor initial vertical alignment. Refer to [DAS-64, "Description"](#).

>> GO TO 2.

2. DISTANCE SENSOR ALIGNMENT

Perform the distance sensor alignment. Refer to [DAS-64, "Description"](#).

>> Work End.

A
B
C
D
E
F
G
H
I
J
K
L
M
N
P

DAS

U1000 CAN COMM CIRCUIT

< DTC/CIRCUIT DIAGNOSIS >

[DRIVER ASSISTANCE SYSTEM]

NO >> Refer to [GI-45, "Intermittent Incident"](#).

SYSTEM

System Description - Chassis Control

INFOID:000000012421711

- Chassis control to integrally control the driving system was adopted.
- Chassis control module inputs the necessary information for control from CAN communication and each switch and integrally controls each system. Refer to the following table for systems controlled and input/output signals.

System	Reference page
Active Engine Brake	DAS-133. "System Description - Active Engine Brake"
Active Ride Control	DAS-134. "System Description - Active Ride Control"
Active Trace Control	DAS-134. "System Description - Active Trace Control"

SYSTEM DIAGRAM

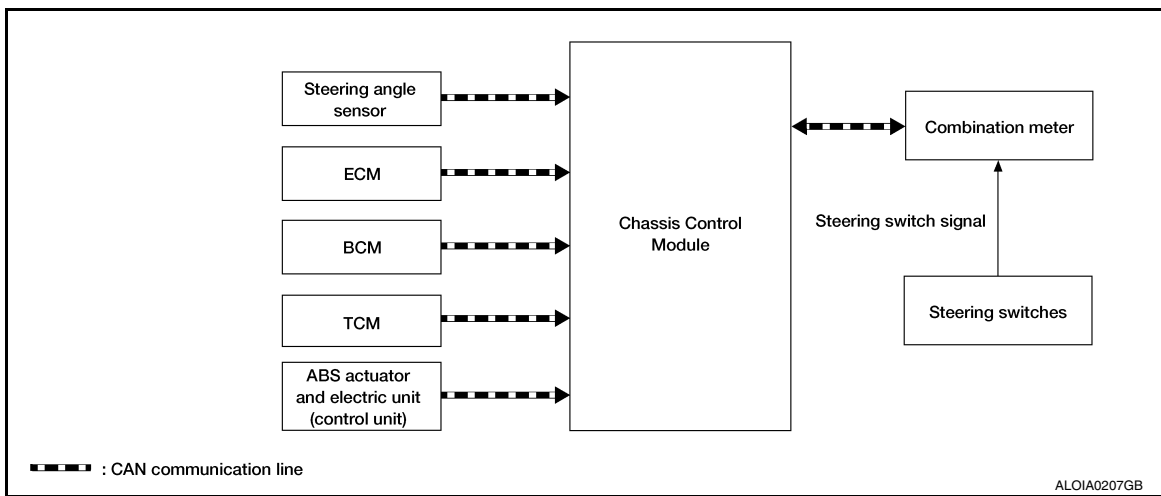

System Description - Active Engine Brake

INFOID:000000012421712

Active Engine Brake function can be switched ON/OFF through the "Chassis Control" settings on the vehicle information display.

- Assist at corners - to lessen the workload of adjusting speed with brake pedal operations at corners. Active Engine Brake function adds small amount of deceleration by controlling the CVT gear ratio depending on the steering input and various sensors. This benefits to easier traceability at corners.

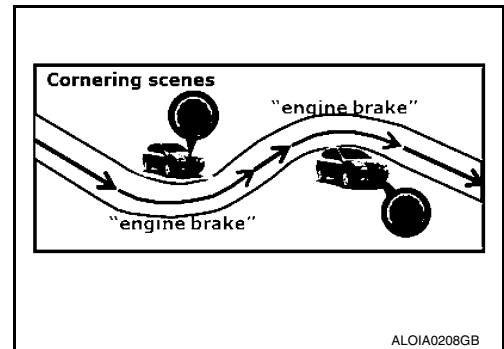

A
B
C
D
E
F
G
H
I
J
K
L
M
N
P

DAS

C1B93-00 ENGINE/HEV SYSTEM

< DTC/CIRCUIT DIAGNOSIS >

[CHASSIS CONTROL]

YES ("U1000-00")>>Refer to [DAS-208. "Diagnosis Procedure"](#).

YES (other DTC)>>Check the DTC.

NO >> Inspection End.

C1BC4-00 DECEL G SENSOR

< DTC/CIRCUIT DIAGNOSIS >

[CHASSIS CONTROL]

NO >> Inspection End.

A

B

C

D

E

F

G

H

I

J

K

L

M

N

DAS

P

PRECAUTIONS

< PRECAUTION >

- Then dip a cloth into fresh water, wring the water out of the cloth and wipe the detergent off.
- Then rub with a soft, dry cloth.
- Do not use organic solvent such as thinner, benzene, alcohol or gasoline.
- For genuine leather seats, use a genuine leather seat cleaner.

REAR WINDOW DEFOGGER SWITCH DOES NOT LIGHT, BUT REAR WINDOW DEFOGGER OPERATES

< SYMPTOM DIAGNOSIS >

REAR WINDOW DEFOGGER SWITCH DOES NOT LIGHT, BUT REAR WINDOW DEFOGGER OPERATES

Diagnosis Procedure

INFOID:000000012423360

1. CHECK REAR WINDOW DEFOGGER SWITCH

Check that the rear window defogger switch is operating normally.

Is the inspection result normal?

YES >> Refer to [GI-45, "Intermittent Incident"](#).

NO >> Refer to [DEF-23, "WITH MANUAL A/C : Diagnosis Procedure"](#) or [DEF-23, "WITH AUTO A/C : Diagnosis Procedure"](#).

A
B
C
D
E
F
G
H
I
J
K
DEF
M
N
O
P

DIAGNOSIS AND REPAIR WORK FLOW

< BASIC INSPECTION >

[TRANSFER: TY21C]

YES >> GO TO 7.

NO >> Check harness and connectors based on the information obtained by interview. Refer to [GI-45](#), "[Intermittent Incident](#)".

7. FINAL CHECK

With CONSULT

1. Check the reference value for AWD control unit.
2. Recheck the symptom and check that symptom is not reproduced on the same conditions.

Is the symptom reproduced?

YES >> GO TO 3.

NO >> Inspection End.

Diagnostic Work Sheet

INFOID:0000000012428280

Description

- In general, customers have their own criteria for a problem. Therefore, it is important to understand the symptom and status well enough by asking the customer about his/her concerns carefully. To systemize all the information for the diagnosis, prepare the interview sheet referring to the interview points.
- In some cases, multiple conditions that appear simultaneously may cause a DTC to be detected.

Interview sheet sample

Interview sheet					
Customer name	MR/MS	Registration number		Initial year registration	
		Vehicle type		VIN	
Storage date		Engine		Mileage	km (Mile)
Symptom		<input type="checkbox"/> Vehicle does not enter AWD mode.			
		<input type="checkbox"/> AWD warning (AWD Error) is displayed.			
		<input type="checkbox"/> Heavy tight-corner braking symptom occurs			
		<input type="checkbox"/> Noise <input type="checkbox"/> Vibration			
		<input type="checkbox"/> Others (_____)			
First occurrence		<input type="checkbox"/> Recently <input type="checkbox"/> Others (_____)			
Frequency of occurrence		<input type="checkbox"/> Always <input type="checkbox"/> Under a certain conditions of <input type="checkbox"/> Sometimes (time(s)/day)			
Climate conditions	<input type="checkbox"/> Irrelevant				
	Weather	<input type="checkbox"/> Fine <input type="checkbox"/> Cloud <input type="checkbox"/> Rain <input type="checkbox"/> Snow <input type="checkbox"/> Others (_____)			
	Temperature	<input type="checkbox"/> Hot <input type="checkbox"/> Warm <input type="checkbox"/> Cool <input type="checkbox"/> Cold <input type="checkbox"/> Temperature (Approx. _____ °C)			
Relative humidity		<input type="checkbox"/> High <input type="checkbox"/> Moderate <input type="checkbox"/> Low			
Road conditions		<input type="checkbox"/> Urban area <input type="checkbox"/> Suburb area <input type="checkbox"/> High way <input type="checkbox"/> Mounting road (uphill or down hill) <input type="checkbox"/> Rough road			
Operation conditions, etc.		<input type="checkbox"/> Irrelevant <input type="checkbox"/> When engine starts <input type="checkbox"/> During idling <input type="checkbox"/> During driving <input type="checkbox"/> During acceleration <input type="checkbox"/> At constant speed driving <input type="checkbox"/> During deceleration <input type="checkbox"/> During cornering (right curve or left curve)			

TRANSFER OIL

< PERIODIC MAINTENANCE >

[TRANSFER: TY21C]

CAUTION:
Do not reuse gasket.

A

B

C

DLN

E

F

G

H

I

J

K

L

M

N

O

P

REAR PROPELLER SHAFT

< REMOVAL AND INSTALLATION >

[REAR PROPELLER SHAFT: C-CVJ-C]

- Install propeller shaft (1) while aligning its matching marks (A) on propeller shaft with matching mark (B) on electric controlled coupling (2) and join them as close as possible.

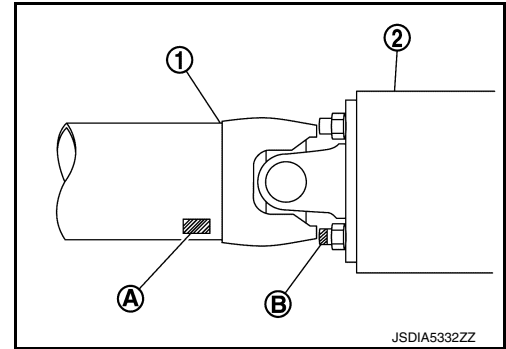

INFOID:000000012428363

Inspection

INSPECTION AFTER REMOVAL

Appearance

Check propeller shaft tube surface for dents or cracks. If malfunction is detected, replace propeller shaft assembly.

Propeller Shaft Runout

Check propeller shaft runout at measuring points with a dial indicator. If runout exceeds specifications, replace propeller shaft assembly.

Propeller shaft runout : Refer to [DLN-104, "Propeller Shaft Runout"](#).

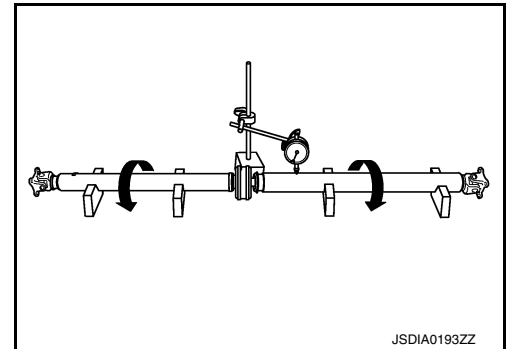

- Propeller shaft runout measuring point (Point "△").

⇐ : Front side

Dimension

A : 541.5 mm (21.32 in)

B : 488.7 mm (19.24 in)

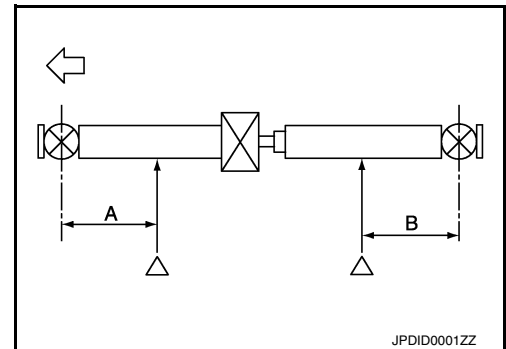

Journal Axial Play

As shown in the figure, while fixing yoke on one side, check axial play of joint. If it is outside the standard, replace propeller shaft assembly.

Journal axial play : Refer to [DLN-104, "Journal Axial Play"](#).

CAUTION:
Never disassemble joints.

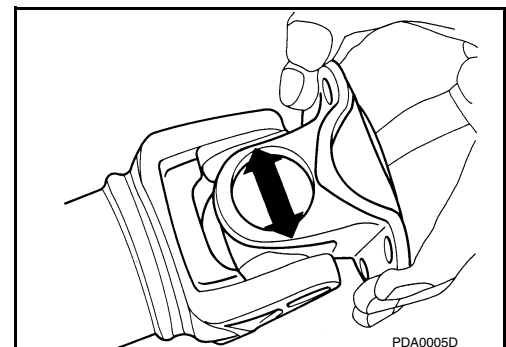

Center Bearing

Check center bearing for noise and damage. If malfunction is detected, replace propeller shaft assembly.



CAUTION:

DRIVE PINION

< UNIT DISASSEMBLY AND ASSEMBLY >

[REAR FINAL DRIVE: R145]

 Apply Genuine Silicone RTV or equivalent. Refer to [GI-22. "Recommended Chemical Products and Sealants"](#).

  Apply Genuine High Strength Thread Locking Sealant or equivalent. Refer to [GI-22. "Recommended Chemical Products and Sealants"](#).

Disassembly and Assembly

INFOID:000000012428394

DISASSEMBLY

1. Remove electric controlled coupling assembly. Refer to [DLN-122. "Disassembly and Assembly"](#).
2. Remove differential assembly. Refer to [DLN-126. "Disassembly and Assembly"](#).
3. Remove drive pinion oil seal, using oil seal remover (commercial service tool).
4. Fit drive pinion socket (A) onto drive pinion spline. Remove drive pinion lock nut, using the pinion nut wrench (B).

A : Drive pinion socket [SST: KV38109500 (—)]

B : Pinion nut wrench [SST: KV38109400 (—)]

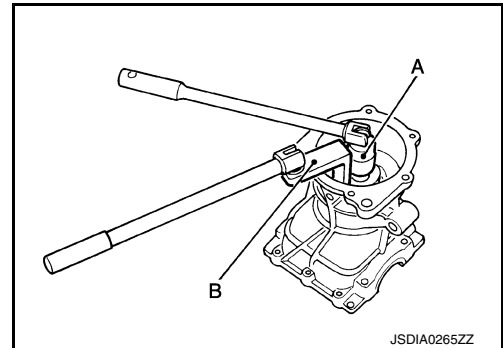

5. Press drive pinion assembly out of gear carrier.

CAUTION:

Never drop drive pinion assembly.

6. Remove pinion front bearing inner race.
7. Remove collapsible spacer.

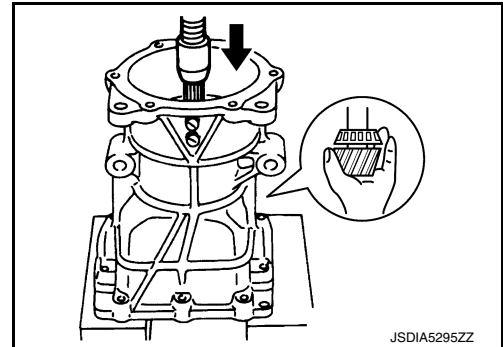

8. Remove pinion rear bearing inner race from drive pinion, using the separator (A) and the puller (B).

A : Separator (commercial service tool)

B : Puller (commercial service tool)

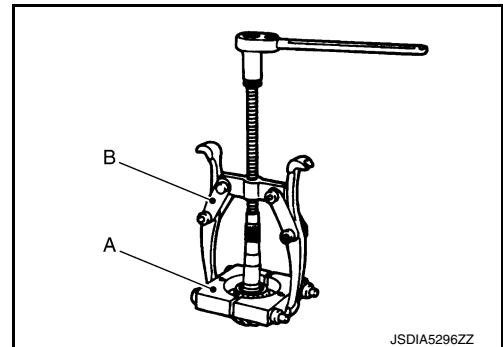

9. Using a brass rod or equivalent (A), tap pinion front bearing outer race evenly from the 2 cutouts on gear carrier and remove pinion front bearing outer race.

CAUTION:

Be careful not to damage gear carrier.

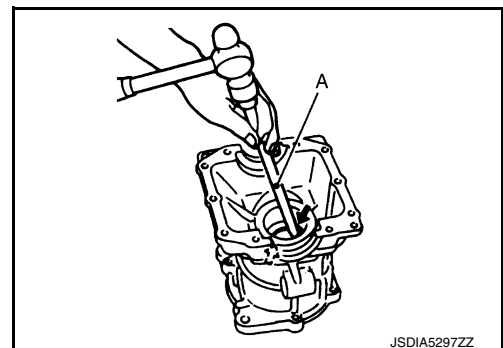

A
B
C
DLN
E
F
G
H
I
J
K
L
M
N
O
P

BASIC INSPECTION

DIAGNOSIS AND REPAIR WORK FLOW

Work Flow

INFOID:000000012421840

DETAILED FLOW

1.OBTAIN INFORMATION ABOUT SYMPTOM

Interview the customer to obtain as much information as possible about the conditions and environment under which the malfunction occurs.

>> GO TO 2.

2.CHECK SYMPTOM

- Check the symptom based on the information obtained from the customer.
- Check if any other malfunctions are present.

>> GO TO 3.

3.DTC/SYSTEM DIGANOSIS

Perform a DTC/system diagnosis and repair or replace any malfunctioning part.

>> GO TO 4.

4.FINAL CHECK

Check that the ECO mode functions normally.

Does it operation normally?

- YES >> End of trouble diagnosis
NO >> GO TO 2.

DIAGNOSIS SYSTEM (IPDM E/R)

[HALOGEN HEADLAMP]

< SYSTEM DESCRIPTION >

DIAGNOSIS SYSTEM (IPDM E/R)

CONSULT Function (IPDM E/R)

INFOID:000000012731444

APPLICATION ITEM

CONSULT performs the following functions via CAN communication with IPDM E/R.

Direct Diagnostic Mode	Description
ECU Identification	The IPDM E/R part number is displayed.
Self Diagnostic Result	The IPDM E/R self diagnostic results are displayed.
Data Monitor	The IPDM E/R input/output data is displayed in real time.
Active Test	The IPDM E/R activates outputs to test components.
CAN Diag Support Mntr	The result of transmit/receive diagnosis of CAN communication is displayed.

ECU IDENTIFICATION

The IPDM E/R part number is displayed.

SELF DIAGNOSTIC RESULT

Refer to [PCS-26, "DTC Index"](#).

DATA MONITOR

Monitor Item [Unit]	Description
REVERSE SIGNAL [Open/Close]	Indicates condition of transmission range switch R (Reverse) position.
IGN RELAY [Open/Close]	Indicates condition of ignition relay-1.
PUSH SW [Open/Close]	Indicates condition of push-button ignition switch.
INTERLOCK/PNP SW [Open/Close]	Indicates condition of transmission range switch P (Park) and N (Neutral) positions.
OIL PRESSURE SW [Open/Close]	Indicates condition of oil pressure switch.
HOOD SW [Open/Close]	Indicates condition of hood switch.
COMPRESSOR [OFF/ON]	Indicates condition of A/C compressor.
HORN RELAY [OFF/ ON]	Indicates condition of horn relay.
COOLING FAN [OFF/ON]	Indicates condition of cooling fan relay-1.
FRONT WIPER HI/LO RELAY [OFF/ON]	Indicates condition of front wiper high relay.
FRONT WIPER RELAY [OFF/ON]	Indicates condition of front wiper relay.
IGN RELAY OFF STATUS [OFF/ON]	Indicates condition of ignition relay-1 OFF status.
IGN RELAY ON STATUS [OFF/ON]	Indicates condition of ignition relay-1 ON status.
COOLING FAN RELAY 1 [OFF/ON]	Indicates condition of cooling fan relay-1.
STARTER RELAY [OFF/ON]	Indicates condition of starter relay.
COMP ECV DUTY [%]	Indicates condition of A/C compressor.
COOLING FAN RELAY 2 [%]	Indicates condition of cooling fan relay-2.
FR FOG LAMP LH [%]	Indicates condition of front fog lamp LH.
FR FOG LAMP RH [%]	Indicates condition of front fog lamp RH.
PARKING LAMP [%]	Indicates condition of parking lamp.
TAIL LAMP LH [%]	Indicates condition of tail lamp LH.
TAIL LAMP RH [%]	Indicates condition of tail lamp RH.
DAYTIME RUNNING LIGHT LH [%]	Indicates condition of daytime running light LH.
DAYTIME RUNNING LIGHT RH [%]	Indicates condition of daytime running light RH.
HEADLAMP (HI) LH [%]	Indicates condition of headlamp high beam LH.

TURN SIGNAL AND HAZARD WARNING LAMP SYSTEM

< WIRING DIAGRAM >

[HALOGEN HEADLAMP]

TURN SIGNAL AND HAZARD WARNING LAMPS CONNECTORS

Connector No.	M6
Connector Name	JOINT CONNECTOR-M01
Connector Color	GRAY

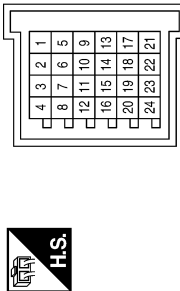

Terminal No.	Color of Wire	Signal Name
3	P	-
4	L	-
7	P	-
8	L	-

Connector No.	M18
Connector Name	BCM (BODY CONTROL MODULE)
Connector Color	GRAY

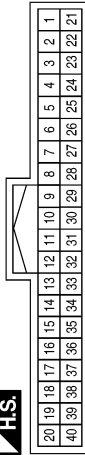

Terminal No.	Color of Wire	Signal Name
2	LA/G	O D I FR LEFT D
3	LAY	O D I FR RIGHT D
11	Y	I HAZARD SW D
33	LG	I CSW 5
34	Y	O CSW 5
36	G	I CSW 3
37	GR	I CSW 4
38	V	I CSW 1
39	W	I CSW 2

Connector No.	M19
Connector Name	BCM (BODY CONTROL MODULE)
Connector Color	BLACK

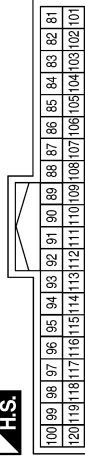

Terminal No.	Color of Wire	Signal Name
84	BR	O CSW 2
85	SB	O CSW 1
86	P	O CSW 3
87	BG	O CSW 4
95	V	I SHORTING PIN

Connector No.	M20
Connector Name	BCM (BODY CONTROL MODULE)
Connector Color	BROWN



Terminal No.	Color of Wire	Signal Name
161	W	I PWR ECU
168	BG	I PWR FLASHERS
170	B	I GND1
171	B	I GND2

Connector No.	M26
Connector Name	HAZARD SWITCH
Connector Color	WHITE



Terminal No.	Color of Wire	Signal Name
2	Y	-
3	GR	-

TURN SIGNAL LAMP CIRCUIT

< DTC/CIRCUIT DIAGNOSIS >

[HALOGEN HEADLAMP]

TURN SIGNAL LAMP CIRCUIT

Description

INFOID:000000012422999

The BCM monitors inputs from the combination switch (lighting and turn signal switch) to determine when to activate the turn signals. The BCM outputs voltage direction to the left and right turn signals during turn signal operation or both during hazard warning operation. The BCM sends a turn signal indicator request to the combination meter via the CAN communication lines.

The BCM performs the fast flasher operation (fail-safe) if any bulb or harness of the turn signal lamp circuit is open.

NOTE:

Turn signal lamp blinks at normal speed when using the hazard warning lamp.

Component Function Check

INFOID:000000012423000

1. CHECK TURN SIGNAL LAMP

CONSULT

1. Select "FLASHER" in "Active Test" of "BCM (FLASHER)".
2. While operating the test items, check that the turn signal lamp blinks.

- LH** : Turn signal lamps (LH) ON
- RH** : Turn signal lamps (RH) ON
- Off** : Turn signal lamps OFF

Is the inspection result normal?

- YES >> Turn signal lamp circuit is normal.
- NO >> Refer to [EXL-93, "Diagnosis Procedure"](#).

Diagnosis Procedure

INFOID:000000012423001

Regarding Wiring Diagram information, refer to [EXL-57, "Wiring Diagram"](#).

1. CHECK TURN SIGNAL LAMP BULB

Check the applicable lamp bulb to be sure the proper bulb standard is in use and the bulb is not open.

Is the bulb OK?

- YES >> GO TO 2.
- NO >> Replace the bulb.

2. CHECK TURN SIGNAL LAMP OUTPUT VOLTAGE

1. Turn the ignition switch OFF.
2. Disconnect the front combination lamp harness connector, door mirror harness connector or the side turn signal harness connector or the rear combination lamp harness connector in question.
3. Turn the ignition switch ON.
4. Operate the turn signal switch.
5. While the turn signal is operating, check the voltage between the front combination lamp harness connector and ground.

(+)		(-)	Voltage (Approx.)
Connector	Terminal		

REAR COMBINATION LAMP

< REMOVAL AND INSTALLATION >

[HALOGEN HEADLAMP]

REAR COMBINATION LAMP

Exploded View

INFOID:000000012423051

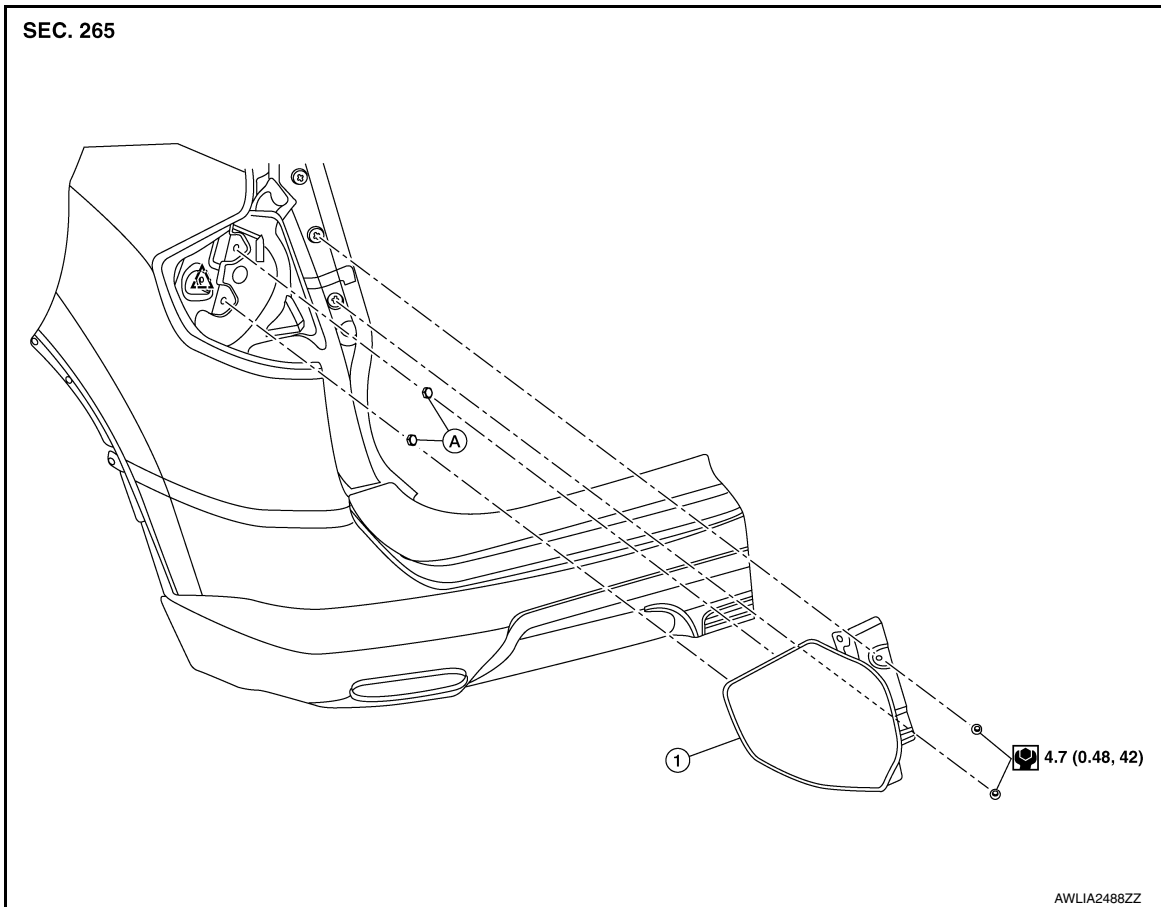

1. Rear combination lamp

A. Grommet

Clip

Removal and Installation

INFOID:000000012423052

REMOVAL

1. Remove side air spoiler. Refer to [EXT-48. "Removal and Installation"](#).
2. Remove rear combination lamp bolts.
3. Pull rear combination lamp rearward to release from clip and locators.
4. Disconnect the harness connector from the rear combination lamp and remove.

INSTALLATION

Installation is in the reverse order of removal.

Bulb Replacement

INFOID:000000012423053

WARNING:

Do not touch bulb with bare hand while it is lit or right after being turned off. Burning may result.

CAUTION:

- Do not touch the glass surface of the bulb with bare hands or allow oil or grease to get on it to prevent damage to the bulb.
- Do not leave bulb out of lamp reflector for a long time because dust, moisture smoke, etc. may affect the performance of lamp. When replacing bulb, be sure to replace it with new one.

STOP LAMP BULB

HEADLAMP

< WIRING DIAGRAM >

[LED HEADLAMP]

Connector No.	M43
Connector Name	JOINT CONNECTOR-M02
Connector Color	BLUE

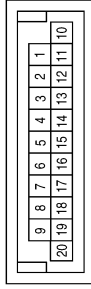

Terminal No.	Color of Wire	Signal Name
1	L	-
2	L	-
5	L	-
11	P	-
12	P	-
15	P	-

Terminal No.	Color of Wire	Signal Name
60J	P	-
61J	L	-

Connector No.	M31
Connector Name	WIRE TO WIRE
Connector Color	WHITE

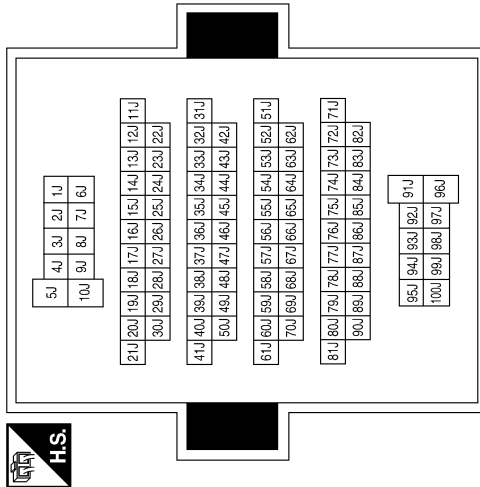

Connector No.	M69
Connector Name	WIRE TO WIRE
Connector Color	WHITE

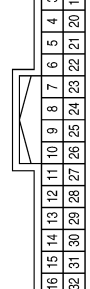

Terminal No.	Color of Wire	Signal Name
24	P	-
25	L	-

Connector No.	M68
Connector Name	FUSE BLOCK (J/B)
Connector Color	BROWN



Terminal No.	Color of Wire	Signal Name
3R	V	-
14R	W	-

Connector No.	M44
Connector Name	FUSE BLOCK (J/B)
Connector Color	WHITE



Terminal No.	Color of Wire	Signal Name
8P	LA/BR	-
13P	LA/G	-

AALIA2983GB

A
B
C
D
E
F
G
H
I
J
K
EXL
M
N
O
P

PARKING, LICENSE PLATE AND TAIL LAMPS SYSTEM

< WIRING DIAGRAM >

[LED HEADLAMP]

Connector No.	E40
Connector Name	WIRE TO WIRE
Connector Color	WHITE



Terminal No.	Color of Wire	Signal Name
2	GR	-
3	B	-

Terminal No.	99A	Color of Wire	W	Signal Name	-
--------------	-----	---------------	---	-------------	---

Connector No.	E34
Connector Name	WIRE TO WIRE
Connector Color	GRAY

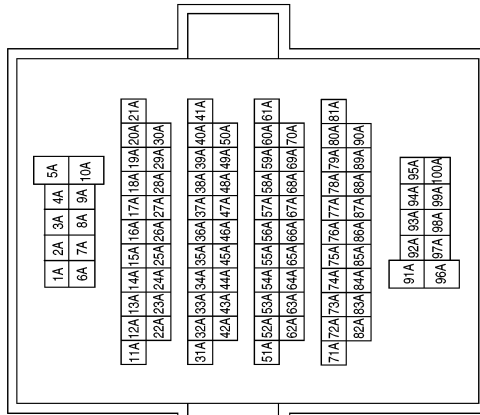

Connector No.	E119
Connector Name	IPDM E/R (INTELLIGENT POWER DISTRIBUTION MODULE ENGINE ROOM)
Connector Color	GRAY

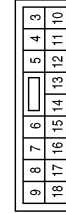

Terminal No.	Color of Wire	Signal Name
4	Y	O LIGHT POSITION REAR LH
12	B	SIGNAL GROUND
17	W	O LIGHT POSITION REAR RH

Terminal No.	5	Color of Wire	L	Signal Name	-
	6	Color of Wire	P	Signal Name	-
	9	Color of Wire	L	Signal Name	-
	10	Color of Wire	P	Signal Name	-

Connector No.	E44
Connector Name	JOINT CONNECTOR-E01
Connector Color	WHITE

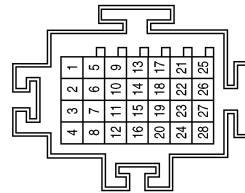

AALIA2959GB

B20CF HEADLAMP (HI) RH POWER SUPPLY CIRCUIT

< DTC/CIRCUIT DIAGNOSIS >

[LED HEADLAMP]

B20CF HEADLAMP (HI) RH POWER SUPPLY CIRCUIT

DTC Logic

INFOID:0000000012423134

DTC DETECTION LOGIC

DTC	Display Item	Malfunction detected condition	Possible causes
B20CF	HL (HI) RH PWR SPLY CIRC [CIRC SHORT TO GRND]	Short to ground	<ul style="list-style-type: none">IPDM E/RShort to ground

DTC CONFIRMATION PROCEDURE

1. CHECK SELF DIAGNOSTIC RESULT

 With CONSULT.

1. Turn ignition switch ON.

2. Perform "Self Diagnostic Result".

Is DTC B20CF detected?

YES >> Proceed to diagnosis procedure. Refer to [EXL-233, "Diagnosis Procedure"](#).

NO >> Inspection End.

Diagnosis Procedure

INFOID:0000000012423135

1. CHECK HEAD LAMP SHORT CIRCUIT TO GROUND

1. Disconnect front combination lamp connector and IPDM E/R connector.

2. Check continuity between IPDM E/R harness connector and ground.

IPDM E/R		Ground	Continuity
Connector	Terminal		
E217	54		No

Is the inspection result normal?

YES >> GO TO 2.

NO >> Repair or replace harness.

2. CHECK HEAD LAMP SHORT CIRCUIT TO GROUND

1. Reconnect IPDM E/R connector.

2. Check continuity between front combination lamp harness connector and ground.

Front combination lamp			Ground	Continuity
Connector		Terminal		
RH	E240	5		No

Is the inspection result normal?

YES >> Refer to [GI-45, "Intermittent Incident"](#).

NO >> Replace IPDM E/R. Refer to [PCS-44, "Removal and Installation"](#).

FRONT COMBINATION LAMP

< UNIT DISASSEMBLY AND ASSEMBLY >

[LED HEADLAMP]

UNIT DISASSEMBLY AND ASSEMBLY

FRONT COMBINATION LAMP

Exploded View

INFOID:000000012423193

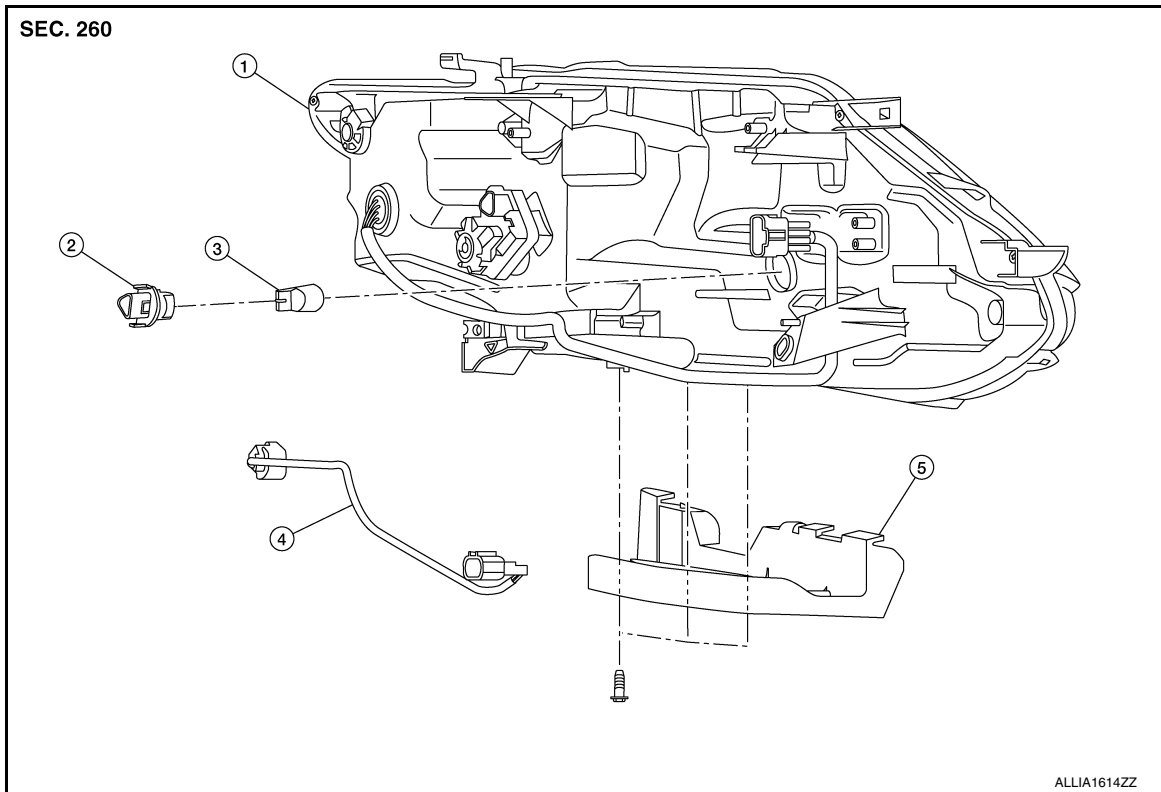

- | | | |
|-----------------------------------|--|--------------------------|
| 1. Front combination lamp | 2. Turn signal lamp bulb socket | 3. Turn signal lamp bulb |
| 4. Front combination lamp harness | 5. Front combination lamp mounting bracket | |

Disassembly and Assembly

INFOID:000000012423194

DISASSEMBLY

1. Remove front combination lamp. Refer to [EXL-253, "Removal and Installation"](#).
2. Rotate the turn signal lamp bulb socket counterclockwise and remove.
3. Remove the turn signal lamp bulb from the bulb socket.

ASSEMBLY

Assembly is in the reverse order of disassembly.

MUDGUARD

< REMOVAL AND INSTALLATION >

MUDGUARD

Exploded View

INFOID:000000012424299

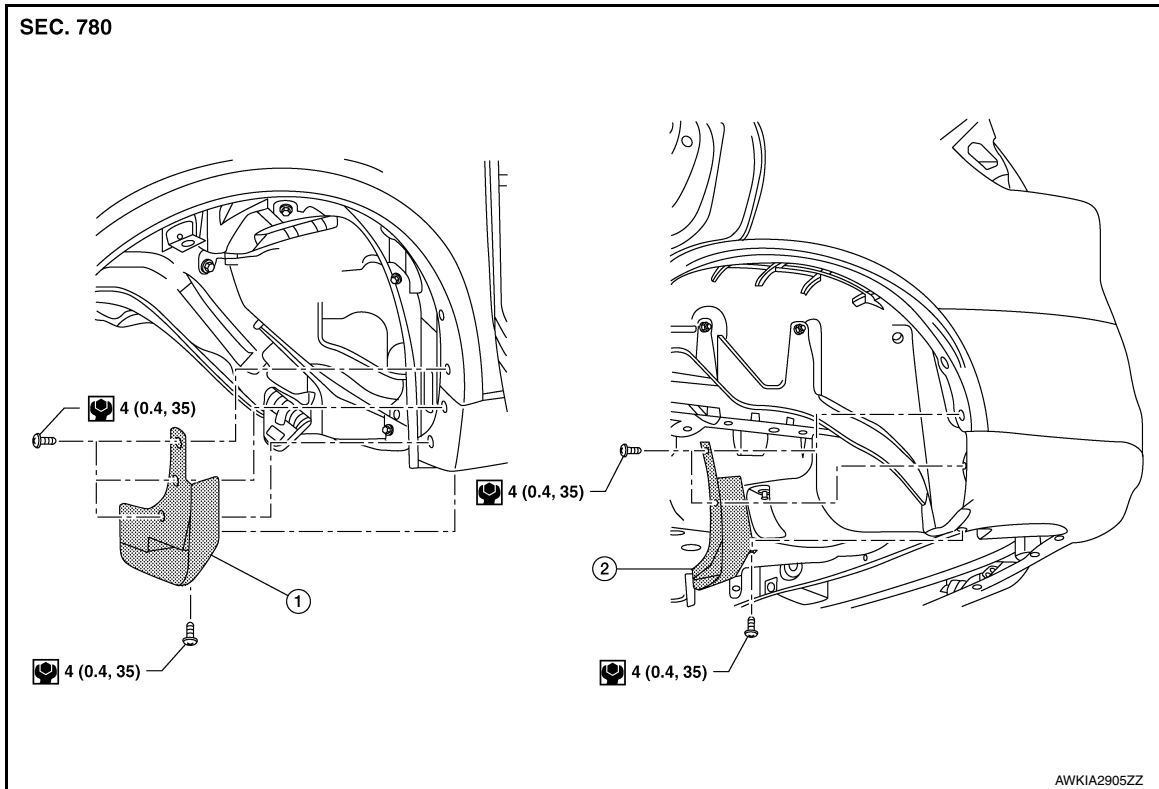

1. Front mudguard

2. Rear mudguard

Removal and Installation

INFOID:000000012424300

EXT

FRONT MUDGUARD

Removal

Remove front mudguard screws and remove front mudguard.

Installation

Installation is in the reverse order of removal.

REAR MUDGUARD

Removal

Remove rear mudguard screws and remove rear mudguard.

Installation

Installation is in the reverse order of removal.

FRONT DRIVE SHAFT BOOT

< REMOVAL AND INSTALLATION >

[FWD]

11. Install new large and small boot bands securely using Tool.

Tool number : KV40107300 (—)

CAUTION:

Do not reuse boot band.

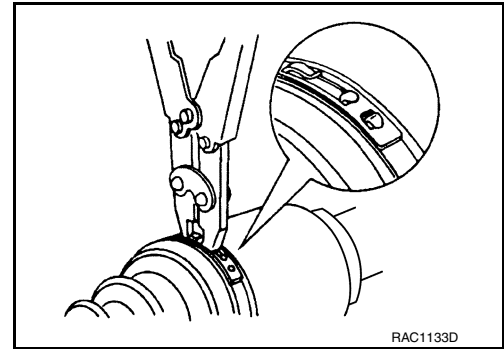

12. Secure boot band so that dimension (M) meets the specification as shown.

Dimension (M) : Refer to [FAX-39, "Drive Shaft"](#).

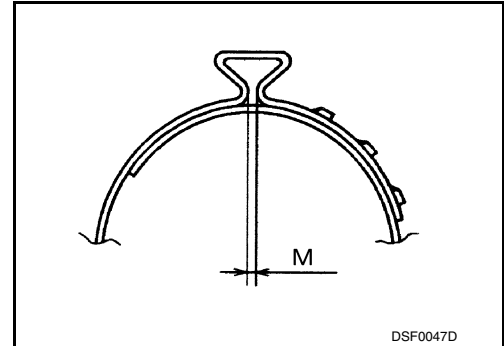

13. Attempt to rotate the boot to check whether or not the boot bands are securing the boot. If the boot is not secure, remove the boot bands, reposition the boot, and install new boot bands.

14. Clean the mating surfaces of the joint sub-assembly and the wheel hub and bearing. Apply Molykote M77 lubricant to the surface (A) of the joint sub-assembly.

CAUTION:

Apply lubricant to cover the entire flat mating surface of the joint sub-assembly.

NOTE:

Always check with the Parts Department for the latest parts information.

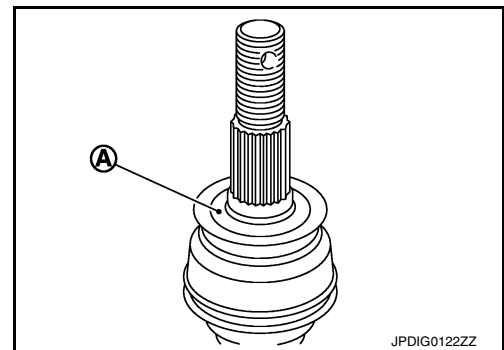

15. Clean the mating surfaces of the wheel hub lock nut and the wheel hub and bearing.

CAUTION:

Do not apply lubricating oil to these mating surfaces.

16. Insert drive shaft to wheel hub and bearing.

17. Temporarily install the wheel hub lock nut.

CAUTION:

Do not reuse the wheel hub lock nut.

18. Install the transverse link to the steering knuckle. Tighten the steering knuckle nut and bolt to the specification. Refer to [FSU-18, "Exploded View"](#).

19. Align the marks on the disc brake rotor (A) and on the wheel hub and bearing. Install the disc brake rotor.

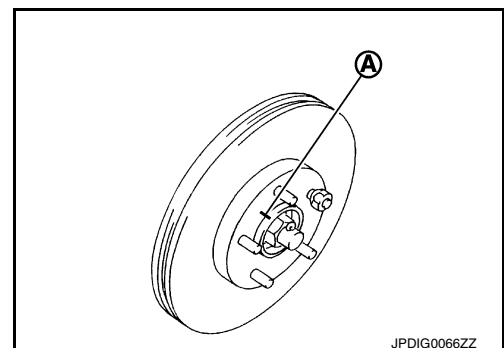

A
B
C
FAX
E
F
G
H
I
J
K
L
M
N
O
P

FRONT DRIVE SHAFT BOOT

[AWD]

< REMOVAL AND INSTALLATION >

- 10. Dust shield
- 13. Support bearing bracket

- 11. Support bearing
- ↔ Wheel side

- 12. Bearing retainer
- A. Refer to FRONT DRIVE SHAFT INSTALLATION

WHEEL SIDE

WHEEL SIDE : Removal and Installation

INFOID:000000012428433

REMOVAL

1. Remove front wheel and tire using power tool. Refer to [WT-67, "Removal and Installation"](#).
2. Remove the bolt (1) and separate the front wheel sensor from the steering knuckle. Refer to [BRC-181, "FRONT WHEEL SENSOR : Removal and Installation"](#).

CAUTION:

- Failure to separate the front wheel sensor from the steering knuckle may result in damage to the front wheel sensor.
- Pull out the front wheel sensor, being careful to turn it as little as possible. Do not pull on front wheel sensor harness

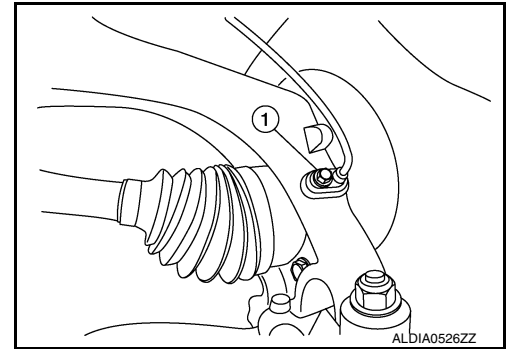

3. Remove brake caliper torque member bolts, leaving brake hose attached. Position the brake caliper aside with wire. Refer to [BR-37, "BRAKE CALIPER ASSEMBLY \(1 PISTON TYPE\) : Exploded View"](#) (1 PISTON TYPE), or [BR-41, "BRAKE CALIPER ASSEMBLY \(2 PISTON TYPE\) : Exploded View"](#) (2 PISTON TYPE).

CAUTION:

Do not depress brake pedal while brake caliper is removed.

4. Put alignment marks (A) on disc brake rotor and wheel hub and bearing. Remove disc brake rotor.

CAUTION:

Do not drop the disc brake rotor.

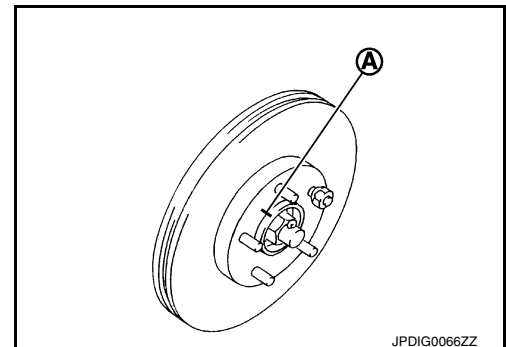

5. Remove cotter pin.
6. Remove the nut retainer.
7. Loosen the wheel hub lock nut from the drive shaft using power tool.
8. Using a piece of wood and a suitable tool, tap on the lock nut to disengage the drive shaft from the wheel hub and bearing.

CAUTION:

- Do not place the drive shaft joint at an extreme angle. Be careful not to over extend the slide joint.
- Do not allow the drive shaft to hang without support.

NOTE:

Use a suitable puller if drive shaft cannot be separated from the wheel hub and bearing.

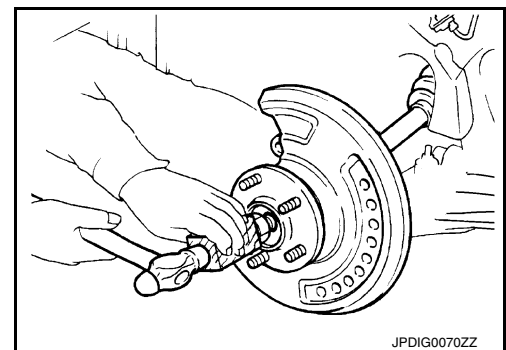

9. Remove the wheel hub lock nut.
10. Remove the engine side cover. Refer to [EXT-29, "FENDER PROTECTOR : Exploded View"](#).
11. Remove the lower nut and bolt from the steering knuckle. Separate the transverse link from the steering knuckle. Refer to [FAX-47, "Exploded View"](#).

FUEL LEVEL SENSOR UNIT, FUEL FILTER AND FUEL PUMP ASSEMBLY

< REMOVAL AND INSTALLATION >

7. Remove the lock ring from the sub fuel level sensor assembly.

Tool number : (—) J-45747 (shown)
: KV101207S0 (—)

↔ : Front

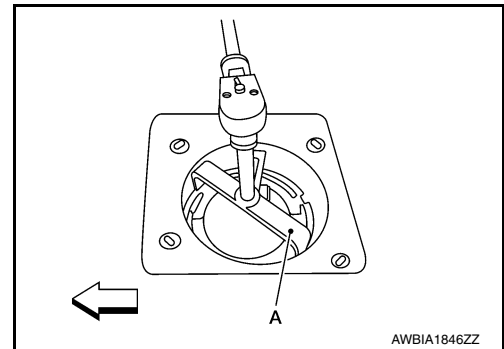

8. Disconnect the fuel tube (1) and the harness connector (A) from the sub fuel level sensor assembly (2) and remove sub fuel level sensor assembly (2).

CAUTION:

- Do not bend float arm during removal.
- Do not pollute the inside by residue fuel. Draw out avoiding inclination by supporting with a cloth.
- Do not cause impacts (banging or dropping) when handling components.

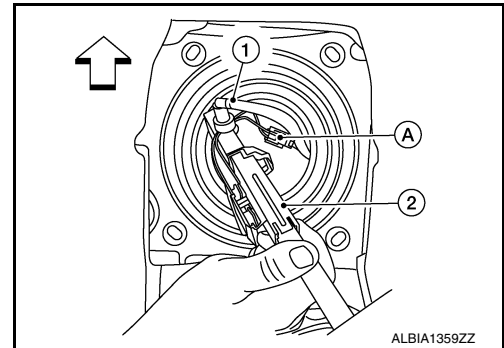

NOTE:

Tie a gasoline resistant rope or wire (A) to the tip of the transfer hose and leave it to the sub fuel level sensor side so that it can be the guide for installation.

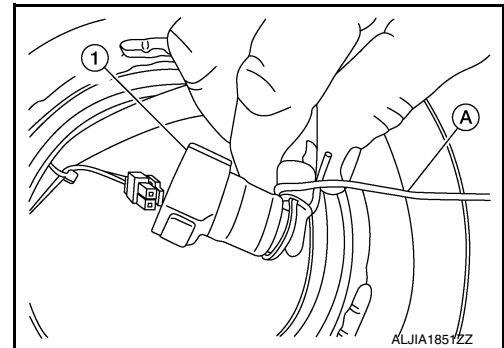

INSTALLATION

Installation is in the reverse order of removal.

- Install O-ring to fuel tank without any twist.

CAUTION:

Do not reuse O-ring.

- Using the rope left on the sub fuel level sensor side at removal, run the fuel tube inside the fuel tank to install the sub fuel level sensor assembly to the fuel tank.

CAUTION:

- Do not bend float arm during installation.

A
FL
C
D
E
F
G
H
I
J
K
L
M
N
O
P

STEERING KNUCKLE

< REMOVAL AND INSTALLATION >

- Put alignment marks (A) on the disc brake rotor and on the wheel hub and bearing. Remove the disc brake rotor.

CAUTION:

Do not drop the disc brake rotor.

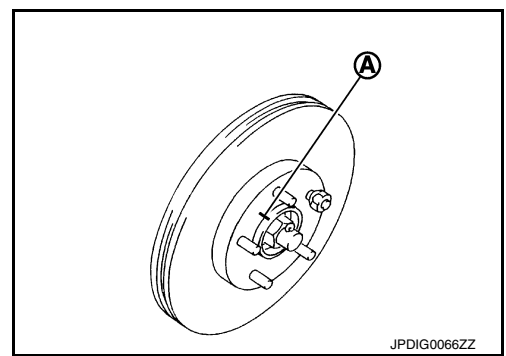

- Remove the cotter pin from the drive shaft.
- Remove the nut retainer from the wheel hub lock nut.
- Loosen the wheel hub lock nut using power tool.
- Using a piece of wood and a suitable tool, tap on the lock nut to disengage the drive shaft from the wheel hub and bearing.

CAUTION:

- Do not place the drive shaft joint at an extreme angle. Be careful not to over extend the slide joint.
- Do not allow the drive shaft to hang without support.

NOTE:

Use a suitable puller if drive shaft cannot be separated from the wheel hub and bearing.

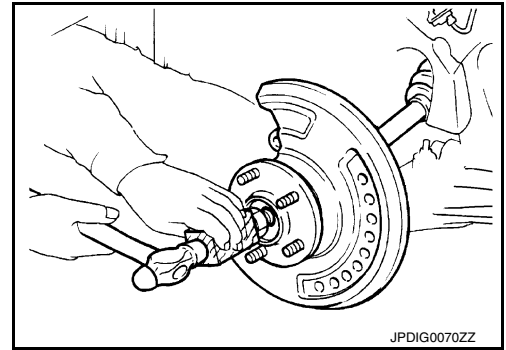

- Remove the wheel hub lock nut. Refer to [FAX-9, "Exploded View"](#) (FWD) or to [FAX-47, "Exploded View"](#) (AWD).
- Remove the nut and separate the stabilizer connecting rod from the strut bracket. Refer to [FSU-15, "Exploded View"](#).
- Remove the lower nut and bolt from the steering knuckle. Separate the transverse link from the steering knuckle. Refer to [FSU-18, "Exploded View"](#).
- Separate drive shaft from wheel hub and bearing.
- Remove the bolts and the wheel hub and bearing and splash guard from the steering knuckle.
- Remove the upper nut and bolt from the steering knuckle.
- Remove the nut and separate the outer socket from the steering knuckle. Refer to [ST-21, "Exploded View"](#).

ABBREVIATIONS

< HOW TO USE THIS MANUAL >

U	
ABBREVIATION	DESCRIPTION
USS	Uphill start support

V	
ABBREVIATION	DESCRIPTION
VCM	Vehicle control module
VDC	Vehicle dynamics control system
VIN	Vehicle identification number
VSS	Vehicle speed sensor

W	
ABBREVIATION	DESCRIPTION
WOT	Wide open throttle

1	
ABBREVIATION	DESCRIPTION
11	1st range first gear
12	1st range second gear
1GR	First gear

2	
ABBREVIATION	DESCRIPTION
21	2nd range first gear
22	2nd range second gear
2GR	Second gear
2WD	2-wheel drive

3	
ABBREVIATION	DESCRIPTION
3GR	Third gear

4	
ABBREVIATION	DESCRIPTION
4GR	Fourth gear
4WAS	Four wheel active steer
4WD	Four wheel drive

5	
ABBREVIATION	DESCRIPTION
5GR	Fifth gear

6	
ABBREVIATION	DESCRIPTION
6GR	Sixth gear

7	
ABBREVIATION	DESCRIPTION
7GR	Seventh gear

CONSULT/GST CHECKING SYSTEM

< BASIC INSPECTION >

CONSULT/GST CHECKING SYSTEM

GI

Description

INFOID:0000000012429859

NOTE:

This vehicle is diagnosed using the CONSULT-III plus.

- When CONSULT is connected with a data link connector equipped on the vehicle side, it will communicate with the control unit equipped in the vehicle and then enable various kinds of diagnostic tests.

- 1 : Hood release handle
- 2 : Data link connector

- Refer to "CONSULT-III plus Operation Manual" for more information.

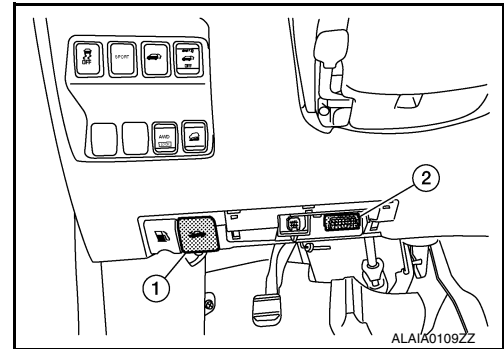

Function and System Application

INFOID:0000000012429860

Diagnosis (All Systems)	Description	ENGINE	ABS	METER/M&A	BCM	CAN GATEWAY	AIR BAG	TRANSMISSION	EPS/DAST 3	IPDM E/R	AVM	TELEMATICS ¹	ICC/ADAS ¹	SIDE RADAR LEFT ¹	SIDE RADAR RIGHT ¹	AIR PRESSURE MONITOR	ALL MODE AWD/4WD ¹	CHASSIS CONTROL	HVAC	ATUO BACK DOOR ¹	MULTI AV	OCCUPANT DETECTION	
Self Diagnostic Result	The ECU self diagnostic results are displayed.	x	x	x	x	x	x	x	x	x	x	x	x	x	x	x	x	x	x	x	x	x	-
Data Monitor	The ECU input/output data is displayed in real time.	x	x	x	x	x	x	x	x	x	x	x	x	x	x	x	x	x	x	x	x	x	-
Work support	The settings for ECU functions can be changed.	x	x	x	x	-	-	x	-	x	x	x	-	-	-	x	x	-	x	x	-	x	-
Active Test	The ECU activates outputs to test components.	x	x	-	x	-	-	x	-	x	-	x	-	x	x	x	x	x	x	-	-	-	-
ECU identification	The ECU part number is displayed.	x	x	x	x	x	x	x	x	x	x	x	x	x	x	x	x	x	x	x	x	x	-
DTC Work Support	The status of system monitoring tests and the self diagnosis status/results can be confirmed.	x	-	-	-	-	-	-	-	-	-	-	-	-	-	-	-	-	-	-	-	-	-
Warning History	Displays the history of the combination meter warning lamp indicators.	-	-	x	-	-	-	-	-	-	-	-	-	-	-	-	-	-	-	-	-	-	-
TROUBLE DIAG RECORD	Self diagnostic history and trouble diagnosis records in ECU are displayed.	-	-	-	-	-	x	-	-	-	-	-	-	-	-	-	-	-	-	-	-	-	-
CAN Diag	This mode displays network diagnostic results of CAN communication using a diagram.	x	x	x	x	x	x	x	x	x	x	x	x	x	x	x	x	x	x	x	x	x	-
CAN DIAG SUPPORT MNTR	The result of transmit/receive diagnosis of CAN communication is displayed.	x	x	x	x	x	x	x	x	x	x	x	x	x	x	x	x	x	x	x	x	-	-

B
C
D
E
F
G
H
I
J
K
L
M
N
O
P

PRECAUTIONS

< PRECAUTION >

PRECAUTION

PRECAUTIONS

Precaution for Supplemental Restraint System (SRS) "AIR BAG" and "SEAT BELT PRE-TENSIONER"

INFOID:000000012424709

The Supplemental Restraint System such as "AIR BAG" and "SEAT BELT PRE-TENSIONER", used along with a front seat belt, helps to reduce the risk or severity of injury to the driver and front passenger for certain types of collision. Information necessary to service the system safely is included in the SR and SB section of this Service Manual.

WARNING:

- To avoid rendering the SRS inoperative, which could increase the risk of personal injury or death in the event of a collision which would result in air bag inflation, all maintenance must be performed by an authorized NISSAN/INFINITI dealer.
- Improper maintenance, including incorrect removal and installation of the SRS, can lead to personal injury caused by unintentional activation of the system. For removal of Spiral Cable and Air Bag Module, see the SR section.
- Do not use electrical test equipment on any circuit related to the SRS unless instructed to in this Service Manual. SRS wiring harnesses can be identified by yellow and/or orange harnesses or harness connectors.

PRECAUTIONS WHEN USING POWER TOOLS (AIR OR ELECTRIC) AND HAMMERS

WARNING:

- When working near the Airbag Diagnosis Sensor Unit or other Airbag System sensors with the Ignition ON or engine running, DO NOT use air or electric power tools or strike near the sensor(s) with a hammer. Heavy vibration could activate the sensor(s) and deploy the air bag(s), possibly causing serious injury.
- When using air or electric power tools or hammers, always switch the Ignition OFF, disconnect the battery and wait at least three minutes before performing any service.

Precaution for Work

INFOID:000000012424710

- When removing or disassembling each component, be careful not to damage or deform it. If a component may be subject to interference, be sure to protect it with a shop cloth.
- When removing (disengaging) components with a screwdriver or similar tool, be sure to wrap the component with a shop cloth or vinyl tape to protect it.
- Protect the removed parts with a shop cloth and prevent them from being dropped.
- Replace a deformed or damaged clip.
- If a part is specified as a non-reusable part, always replace it with a new one.
- Be sure to tighten bolts and nuts securely to the specified torque.
- After installation is complete, be sure to check that each part works properly.
- Follow the steps below to clean components:
 - Water soluble dirt:
 - Dip a soft cloth into lukewarm water, wring the water out of the cloth and wipe the dirty area.
 - Then rub with a soft, dry cloth.
 - Oily dirt:
 - Dip a soft cloth into lukewarm water with mild detergent (concentration: within 2 to 3%) and wipe the dirty area.
 - Then dip a cloth into fresh water, wring the water out of the cloth and wipe the detergent off.
 - Then rub with a soft, dry cloth.
 - Do not use organic solvent such as thinner, benzene, alcohol or gasoline.
 - For genuine leather seats, use a genuine leather seat cleaner.

COOLER PIPE AND HOSE

< REMOVAL AND INSTALLATION >

Cap or wrap the joint of the pipe with suitable material such as vinyl tape to avoid the entry of air.

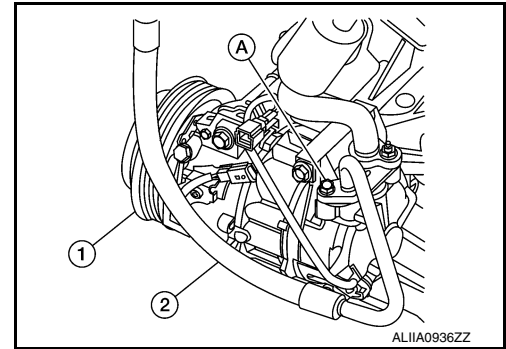

5. Remove the high pressure flexible hose.

INSTALLATION

Installation is in the reverse order of removal.

CAUTION:

- Tighten bolts to specified torque. Refer to [HA-39, "Exploded View"](#).
- Do not reuse O-rings.
- Apply A/C oil to new O-rings for installation.
- Charge refrigerant. Refer to [HA-23, "Charge Refrigerant"](#).
- After charging the refrigerant, check for leaks. Refer to [HA-21, "Leak Test"](#).

DIAGNOSIS SYSTEM (A/C AUTO AMP.)

< SYSTEM DESCRIPTION >

[AUTOMATIC AIR CONDITIONING]

	Test item						
	MODE 1	MODE 2	MODE 3	MODE 4	MODE 5	MODE 6	MODE 7
Mode door position	VENT	VENT	B/L	B/L	D/F1	D/F2	DEF
Intake door position	REC	REC	20%FRE	20%FRE	FRE	FRE	FRE
Air mix door position (driver & passenger side)	FULL COLD	FULL COLD	FULL COLD	FULL HOT	FULL HOT	FULL HOT	FULL HOT
Blower motor (Applied voltage)	35%	35%	60%	60%	90%	90%	35%
A/C compressor (Magnet clutch)	ON	ON	ON	ON	OFF	OFF	ON
ECV duty	80%	80%	40%	40%	0%	0%	90%

NOTE:

Perform the inspection of each output device after starting the engine, because the A/C compressor has been operating.

A
B
C
D
E
F
G
H
J
K
L
M
N
O
P

HAC

B24A1 A/C AUTO AMP. POWER SUPPLY

< DTC/CIRCUIT DIAGNOSIS >

[AUTOMATIC AIR CONDITIONING]

B24A1 A/C AUTO AMP. POWER SUPPLY

DTC Logic

INFOID:000000012424796

DTC DETECTION LOGIC

DTC	Items (CONSULT screen terms)	DTC detection condition	Possible cause
B24A1	A/C AUTO AMP. POWER SUPPLY	A/C auto amp. power supply is out of range	<ul style="list-style-type: none"> A/C auto amp. Harness and connector (Power supply is open or shorted)

DTC CONFIRMATION PROCEDURE

1. PERFORM DTC CONFIRMATION PROCEDURE

Ⓢ With CONSULT

- Turn ignition switch ON.
- Select "Self Diagnostic Result" mode of "HVAC".
- Check DTC.

Is DTC detected?

- YES >> Refer to [HAC-60. "Diagnosis Procedure"](#).
 NO >> Inspection End.

Diagnosis Procedure

INFOID:000000012424797

Regarding Wiring Diagram information, refer to [HAC-38. "Wiring Diagram"](#).

1. CHECK FUSE

Check 10A fuse [No. 20, located in the fuse block (J/B)].

NOTE:

Refer to [PG-66. "Terminal Arrangement"](#).

Is the inspection result normal?

- YES >> GO TO 2.
 NO >> Replace the blown fuse after repairing the affected circuit.

2. CHECK A/C AUTO AMP. POWER SUPPLY

- Turn ignition switch OFF.
- Disconnect A/C auto amp. connector.
- Check voltage between A/C auto amp. harness connector and ground.

+		-	Voltage		
A/C auto amp.			Ignition switch position		
Connector	Terminal		OFF	ACC	ON
M54	1	Ground	Approx. 0 V	Approx. 0 V	Battery voltage

Is the inspection result normal?

- YES >> GO TO 3.
 NO >> Repair harness or connector between A/C auto amp. and fuse block (J/B).

3. CHECK A/C AUTO AMP. GROUND CIRCUIT

- Turn ignition switch OFF.
- Check continuity between A/C auto amp. harness connector and ground.

MAGNET CLUTCH

< DTC/CIRCUIT DIAGNOSIS >

[AUTOMATIC AIR CONDITIONING]

MAGNET CLUTCH

Component Function Check

INFOID:000000012424831

1.CHECK MAGNET CLUTCH OPERATION

Perform "COMPRESSOR" in "Active Test" of "IPDM E/R". Refer to [HAC-26, "CONSULT Function \(IPDM E/R\)".](#)

Does it operate normally?

- YES >> Inspection End.
- NO >> Refer to [HAC-95, "Diagnosis Procedure".](#)

Diagnosis Procedure

INFOID:000000012424832

Regarding Wiring Diagram information, refer to [HAC-38, "Wiring Diagram".](#)

1.CHECK FUSE

1. Turn ignition switch OFF.
2. Check 10A fuse (No. 50, located in IPDM E/R).

NOTE:

Refer to [PG-70, "IPDM E/R Terminal Arrangement".](#)

Is the inspection result normal?

- YES >> GO TO 2.
- NO >> Replace the blown fuse after repairing the affected circuit.

2.CHECK MAGNET CLUTCH POWER SUPPLY CIRCUIT

1. Disconnect A/C compressor connector and IPDM E/R connector.
2. Check continuity between A/C compressor harness connector and IPDM E/R harness connector.

A/C compressor		IPDM E/R		Continuity
Connector	Terminal	Connector	Terminal	
F27	1	F35	65	Yes

Is the inspection result normal?

- YES >> GO TO 3.
- NO >> Repair harness or connector.

3.CHECK MAGNET CLUTCH GROUND CIRCUIT

1. Disconnect A/C compressor connector.
2. Check continuity between A/C compressor harness connector and ground.

A/C compressor			Continuity
Connector	Terminal		
F27	2	Ground	Yes

Is the inspection result normal?

- YES >> GO TO 4.
- NO >> Repair harness or connector.

4.CHECK MAGNET CLUTCH

Directly apply battery voltage to the magnet clutch. Check operation visually and by sound.

Does it operate normally?

- YES >> Replace IPDM E/R. Refer to [PCS-44, "Removal and Installation".](#)
- NO >> Replace magnet clutch. Refer to [HA-30, "Removal and Installation".](#)

A
B
C
D
E
F
G
H
J
K
L
M
N
O
P

HAC

CLICK HERE TO **DOWNLOAD** THE COMPLETE MANUAL

- Thank you very much for reading the preview of the manual.
- You can download the complete manual from: www.heydownloads.com by clicking the link below



- Please note: If there is no response to CLICKING the link, please download this PDF first and then click on it.

CLICK HERE TO **DOWNLOAD** THE COMPLETE MANUAL

DIAGNOSIS SYSTEM (HVAC)

Description

INFOID:000000012424870

Air conditioning system performs self-diagnosis, operation check, function diagnosis, and various settings using diagnosis function of each control unit.

ECU	Diagnostic item (CONSULT)	
Front air control	ⓂHVAC	Self Diagnostic Result
		Data Monitor
		Active Test
		Work support
ECM	ⓂENGINE	Self Diagnostic Result
		Data Monitor
IPDM E/R	ⓂIPDM E/R	Self Diagnostic Result
		Data Monitor

CONSULT Function (HVAC)

INFOID:000000012424871

CONSULT can display each diagnosis item using the diagnosis test modes as shown.

CONSULT application items

Diagnosis mode	Description
Self Diagnostic Result	Displays the diagnosis results judged by A/C auto amp.
Data Monitor	Displays A/C auto amp. input/output data in real time.
Work support	Changes the setting for each system function.
Active Test	The signals used to activate each device are forcibly supplied from front air control.
ECU Identification	Displays the A/C auto amp. number.

SELF DIAGNOSTIC RESULT

Refer to [HAC-142, "DTC Index"](#).

Display Item List

DTC	Items (CONSULT screen terms)	Diagnostic item is detected when...	Possible cause
U1000	CAN COMM CIRCUIT	When A/C auto amp. is not transmitting or receiving CAN communication signal for 2 or more seconds.	CAN communication system
U1010	CONTROL UNIT (CAN)	When detecting error during the initial diagnosis of CAN controller of front air control.	Front air control
B24A4	INTAKE TEMP SEN	Short or open circuit of the intake temperature sensor signal.	<ul style="list-style-type: none"> • Intake sensor • Front air control • Harness and connector (Intake sensor circuit is open, or there is a short in the circuit)
B24BB	AIRMIX ACTR	Short or open circuit of air mix door motor drive signal.	<ul style="list-style-type: none"> • Air mix door motor LH • Front air control • Harness and connector (Air mix door motor is open or shorted)

B24A4 INTAKE SENSOR

< DTC/CIRCUIT DIAGNOSIS >

[MANUAL AIR CONDITIONING]

3. Check resistance between intake sensor terminals.

Terminal		Condition	Resistance: kΩ (Approx.)
		Temperature: °C (°F)	
1	2	-15 (5)	17.73
		-10 (14)	13.46
		-5 (23)	10.33
		0 (32)	8.00
		5 (41)	6.25
		10 (50)	4.93
		15 (59)	3.92
		20 (68)	3.14
		25 (77)	2.54
		30 (86)	2.06
		35 (95)	1.69
		40 (104)	1.39
45 (113)	1.15		

Is the inspection result normal?

YES >> Inspection End.

NO >> Replace intake sensor. Refer to [HAC-191. "Removal and Installation"](#).

A
B
C
D
E
F
G
H
J
K
L
M
N
O
P

HAC

HORN CONNECTORS

Connector No.	M30
Connector Name	COMBINATION SWITCH (SPIRAL CABLE)
Connector Color	WHITE

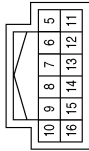

Terminal No.	5	Color of Wire	BG	Signal Name	-
--------------	---	---------------	----	-------------	---

Connector No.	M31
Connector Name	WIRE TO WIRE
Connector Color	WHITE

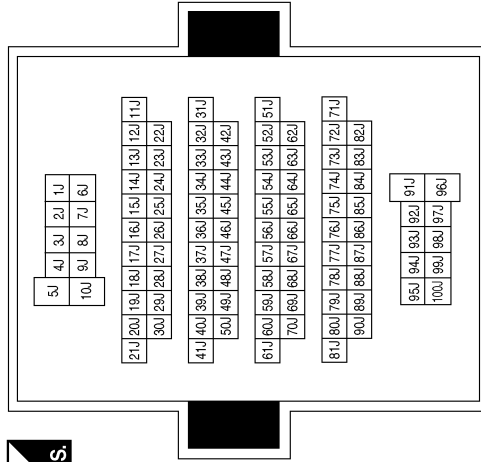

Terminal No.	35J	Color of Wire	BG	Signal Name	-
--------------	-----	---------------	----	-------------	---

Connector No.	M90
Connector Name	COMBINATION SWITCH (SPIRAL CABLE)
Connector Color	WHITE

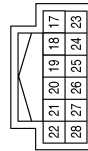

Terminal No.	28	Color of Wire	BR	Signal Name	-
--------------	----	---------------	----	-------------	---

Connector No.	E46
Connector Name	HORN
Connector Color	BLACK



Terminal No.	2	Color of Wire	B	Signal Name	-
--------------	---	---------------	---	-------------	---

Connector No.	E47
Connector Name	HORN
Connector Color	BROWN



Terminal No.	1	Color of Wire	R	Signal Name	-
--------------	---	---------------	---	-------------	---

DIAGNOSIS SYSTEM (BCM) (WITHOUT INTELLIGENT KEY SYSTEM)

< SYSTEM DESCRIPTION >

Monitor Item [Unit]	Description
DOOR SW-DR [On/Off]	Indicates condition of front door switch LH.
DOOR SW-AS [On/Off]	Indicates condition of front door switch RH.
DOOR SW-RR [On/Off]	Indicates condition of rear door switch RH.
DOOR SW-RL [On/Off]	Indicates condition of rear door switch LH.
DOOR SW-BK [On/Off]	Indicates condition of back door switch.
CDL LOCK SW [On/Off]	Indicates condition of lock signal from door lock and unlock switch.
CDL UNLOCK SW [On/Off]	Indicates condition of unlock signal from door lock and unlock switch.
KEY CYL LK-SW [On/Off]	Indicates condition of lock signal from door key cylinder switch.
KEY CYL UN-SW [On/Off]	Indicates condition of unlock signal from door key cylinder switch.
RKE-LOCK [On/Off]	Indicates condition of lock signal from Intelligent Key.
RKE-UNLOCK [On/Off]	Indicates condition of unlock signal from Intelligent Key.

ACTIVE TEST

Test Item	Description
INT LAMP	This test is able to check interior room lamp operation [On/Off].

WORK SUPPORT

Support Item	Setting	Description
SET I/L D-UNLCK INTCON	On*	Interior room lamp timer function ON.
	Off	Interior room lamp timer function OFF.

*: Initial setting

BATTERY SAVER

BATTERY SAVER : CONSULT Function (BCM - BATTERY SAVER)

INFOID:0000000012610860

DATA MONITOR

Monitor Item [Unit]	Description
DOOR SW-DR [On/Off]	Indicates condition of front door switch LH.
DOOR SW-AS [On/Off]	Indicates condition of front door switch RH.
DOOR SW-RR [On/Off]	Indicates condition of rear door switch RH.
DOOR SW-RL [On/Off]	Indicates condition of rear door switch LH.
DOOR SW-BK [On/Off]	Indicates condition of back door switch.
CDL LOCK SW [On/Off]	Indicates condition of lock signal from door lock and unlock switch.
CDL UNLOCK SW [On/Off]	Indicates condition of unlock signal from door lock and unlock switch.
KEY CYL LK-SW [On/Off]	Indicates condition of lock signal from door key cylinder switch.
KEY CYL UN-SW [On/Off]	Indicates condition of unlock signal from door key cylinder switch.
RKE-LOCK [On/Off]	Indicates condition of lock signal from Intelligent Key.
RKE-UNLOCK [On/Off]	Indicates condition of unlock signal from Intelligent Key.

ACTIVE TEST

Test item	Description
BATTERY SAVER	This test is able to check battery saver operation [On/Off].

LUGGAGE ROOM LAMP CIRCUIT

< DTC/CIRCUIT DIAGNOSIS >

LUGGAGE ROOM LAMP CIRCUIT

Description

INFOID:000000012423222

Controls the luggage room lamp (ground side) to turn the luggage room lamp ON and OFF.

Diagnosis Procedure

INFOID:000000012423223

CAUTION:

Before performing the diagnosis, check that the following is normal:

- Interior room lamp power supply
- Luggage room lamp bulb

1. CHECK LUGGAGE ROOM LAMP OUTPUT

1. Turn ignition switch OFF.
2. Remove the luggage room lamp bulb.
3. Check continuity between BCM harness connector and ground.

BCM		Ground	Condition		Continuity
Connector	Terminal		Back door	Open	Yes
B23	151			Closed	No

Is the inspection result normal?

YES >> GO TO 2.

Fixed ON>>GO TO 3.

Fixed OFF>>Replace BCM. Refer to [BCS-76. "Removal and Installation"](#) (with Intelligent Key system) or [BCS-137. "Removal and Installation"](#) (without Intelligent Key system).

2. CHECK LUGGAGE ROOM LAMP OPEN CIRCUIT

1. Disconnect BCM connector.
2. Check continuity between BCM harness connector and luggage room lamp harness connector.

BCM		Luggage room lamp		Continuity
Connector	Terminal	Connector	Terminal	
B23	151	B118	2	Yes

Is the inspection result normal?

YES >> Replace luggage room lamp.

NO >> Repair or replace harnesses.

3. CHECK LUGGAGE ROOM LAMP SHORT CIRCUIT

1. Disconnect BCM connector.
2. Check continuity between BCM harness connector and ground.

BCM		Ground	Continuity
Connector	Terminal		
B23	151		No

Is the inspection result normal?

YES >> Replace BCM. Refer to [BCS-76. "Removal and Installation"](#) (with Intelligent Key system) or [BCS-137. "Removal and Installation"](#) (without Intelligent Key system).

NO >> Repair or replace harnesses.

BODY SIDE TRIM

< REMOVAL AND INSTALLATION >

- Remove front kicking plate. Refer to [INT-23. "KICKING PLATE : Removal and Installation - Front Kicking Plate"](#).
- Partially remove the front door welt.
- Remove rear kicking plate. Refer to [INT-24. "KICKING PLATE : Removal and Installation - Rear Kicking Plate"](#).
- Partially remove the rear door welt.
- Release center pillar lower finisher clips and pawls using a suitable tool, then remove the center pillar lower finisher (1).

- △: Clip
- : Pawl

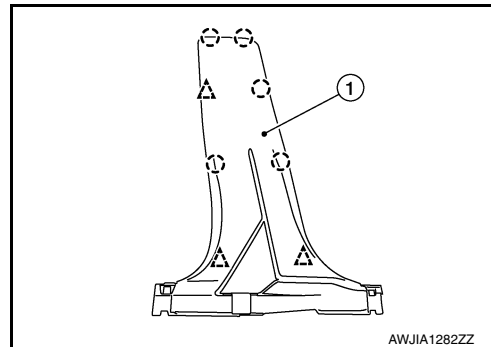

INSTALLATION

Installation is in the reverse order of removal.

CAUTION:

- Visually check the clips for deformation and damage during installation. Replace with new ones if necessary.
- When installing center pillar lower finisher, check that clips and pawls are securely placed in body panel holes.

BODY SIDE WELT

BODY SIDE WELT : Removal and Installation - Front Door Welt

INFOID:000000012424603

REMOVAL

- Remove the front kicking plate. Refer to [INT-23. "KICKING PLATE : Removal and Installation - Front Kicking Plate"](#).
- Remove the front body side welt.

INSTALLATION

Installation is in the reverse order of removal.

BODY SIDE WELT : Removal and Installation - Rear Door Welt

INFOID:000000012424604

REMOVAL

- Remove the rear kicking plate. Refer to [INT-24. "KICKING PLATE : Removal and Installation - Rear Kicking Plate"](#).
- Remove the rear body side welt.

INSTALLATION

Installation is in the reverse order of removal.

KICKING PLATE

KICKING PLATE : Removal and Installation - Front Kicking Plate

INFOID:000000012424605

REMOVAL

CENTER CONSOLE ASSEMBLY

< REMOVAL AND INSTALLATION >

CENTER CONSOLE ASSEMBLY

Exploded View

INFOID:000000012424633

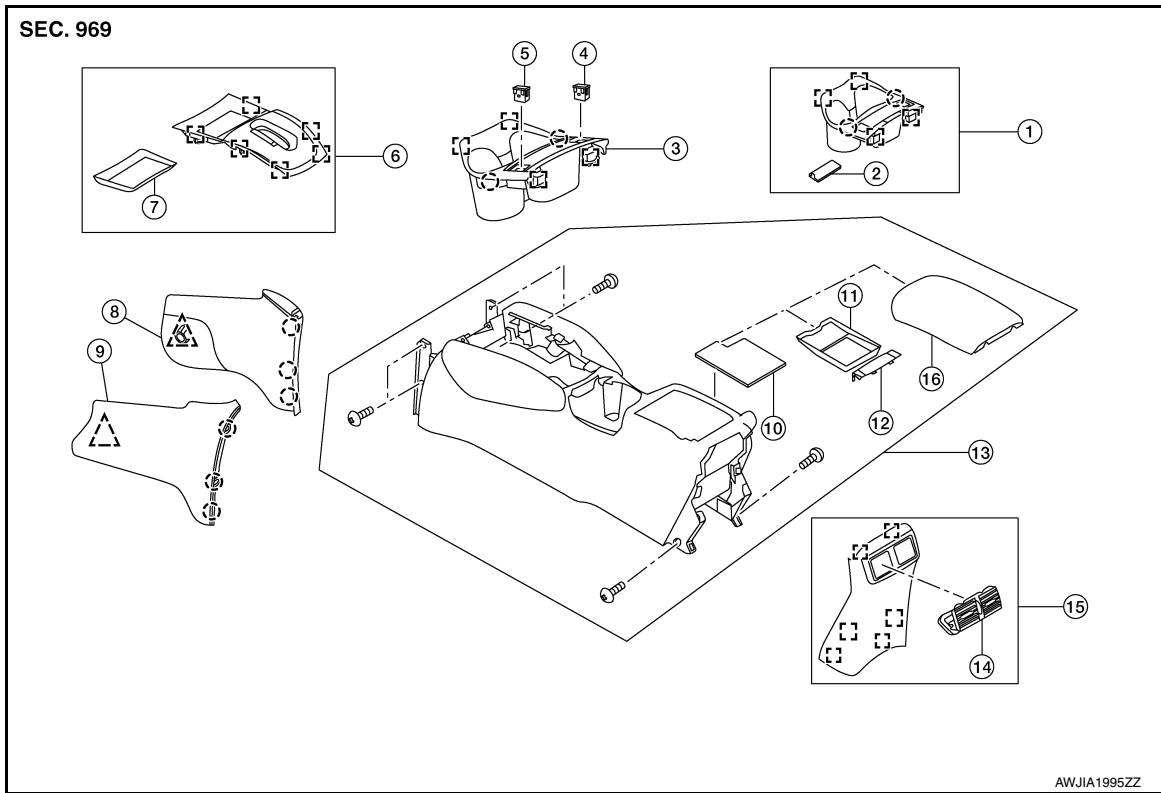

- | | | |
|---|--------------------------------------|--|
| 1. Center console cup holder (without heated seats) | 2. Coin tray insert | 3. Center console cup holder (with heated seats) |
| 4. Front heated seat switch (RH) | 5. Front heated seat switch (LH) | 6. Shift selector finisher |
| 7. Shift selector finisher mat | 8. Center console side finisher (RH) | 9. Center console side finisher (LH) |
| 10. Center console tray | 11. Center console bin mat | 12. Center console rear brace finisher |
| 13. Center console assembly | 14. Rear center ventilator grille | 15. Center console rear finisher |
| 16. Center console bin lid | Metal clip | Clip |
| Pawl | | |

Removal and Installation

INFOID:000000012424634

REMOVAL

1. Release clips and pawls using a suitable tool and remove center console side finisher (1) (LH/RH).

Pawl

Clip

NOTE:

RH side shown; LH similar.

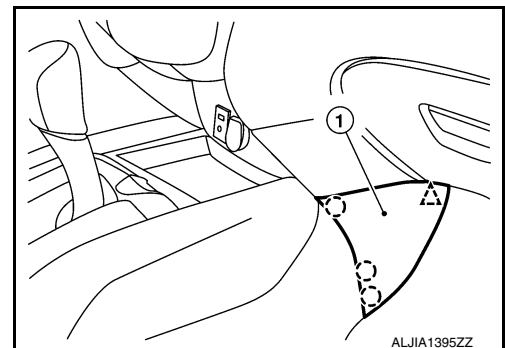

ALJIA1395ZZ

2. Remove shift selector knob. Refer to [TM-193, "Exploded View"](#).
3. Remove cluster lid C. Refer to [IP-22, "Removal and Installation"](#).

PERIODIC MAINTENANCE

< PERIODIC MAINTENANCE >

MAINTENANCE OPERATION		MAINTENANCE INTERVAL						Reference Page
Perform either at number of miles, kilometers or months, whichever comes first.	Miles x 1,000 (km x 1,000)	95 (152)	100 (160)	105 (168)	110 (176)	115 (184)	120 (192)	
		Months	114	120	126	132	138	144
Engine coolant*	NOTE (4)(5)							CO-8
Engine oil		R	R	R	R	R	R	LU-7
Engine oil filter (Use genuine NISSAN engine oil filter or equivalent)		R	R	R	R	R	R	LU-11
Spark plugs (Iridium-tipped type)	NOTE (6)	Replace every 105,000 miles (168,000 km)						EM-19
Intake & exhaust valve clearance*	NOTE (7)							

NOTE:

- (1) After 40,000 miles (64,000 km) or 48 months, inspect every 10,000 miles (16,000 km) or 12 months. Replace the drive belts if found damaged.
- (2) If operating mainly in dusty conditions, more frequent maintenance may be required.
- (3) Maintenance-free item. For service procedures, refer to FL section.
- (4) First replacement interval is 105,000 miles (168,000 km) or 84 months. After first replacement, replace every 75,000 miles (120,000 km) or 60 months.
- (5) Use only Genuine NISSAN Long Life Antifreeze / Coolant (blue) or equivalent with proper mixture ratio of 50% antifreeze and 50% demineralized or distilled water. Mixing any other type of coolant or the use of non-distilled water will reduce the life expectancy of the factory-fill coolant.
- (6) Replace spark plug when the spark plug gap exceeds 1.4 mm (0.055 in), even if within specified periodic replacement mileage.
- (7) Periodic maintenance is not required. However, if valve noise increases, inspect valve clearance.

: Maintenance items and intervals with "" are recommended by NISSAN for reliable vehicle operation. The owner need not perform such maintenance in order to maintain the emission warranty or manufacturer recall liability. Other maintenance items and intervals are required.

CHASSIS AND BODY MAINTENANCE

Abbreviations: R= Replace. I = Inspect. Correct or replace if necessary.

MAINTENANCE OPERATION		MAINTENANCE INTERVAL								
Perform either at number of miles, kilometers or months, whichever comes first.	Miles x 1,000 (km x 1,000)	5 (8)	10 (16)	15 (24)	20 (32)	25 (40)	30 (48)	35 (56)	40 (64)	45 (72)
		Months	6	12	18	24	30	36	42	48
Brake line & cables			I		I		I		I	
Brake pads, rotors★			I		I		I		I	
Brake fluid ★					R				R	
CVT fluid	NOTE (1)		I		I		I		I	
Transfer oil & differential gear oil	NOTE (2)		I		I		I		I	
Steering gear and linkage, axle and suspension parts ★					I				I	
Tire rotation	NOTE (3)									
Propeller shaft (AWD) & drive shaft boots★			I		I		I		I	
Exhaust system★					I				I	
In-cabin microfilter					R				R	
Intelligent key battery					R				R	

MAINTENANCE OPERATION		MAINTENANCE INTERVAL								
Perform either at number of miles, kilometers or months, whichever comes first.	Miles x 1,000 (km x 1,000)	50 (80)	55 (88)	60 (96)	65 (104)	70 (112)	75 (120)	80 (128)	85 (136)	90 (144)
		Months	60	66	72	78	84	90	96	102
Brake line & cables		I		I		I		I		I
Brake pads, rotors ★		I		I		I		I		I

PREPARATION

< PREPARATION >

PREPARATION

PREPARATION

Special Service Tool

INFOID:000000012422938

The actual shape of the tools may differ from those illustrated here.

Tool number (TechMate No.) Tool name	Description
— (J-39570) Chassis Ear	Locating the noise
— (J-46534) Trim Tool Set	Removing trim components
— (J-50397) NISSAN Squeak and Rattle Kit	Repairing the cause of noise

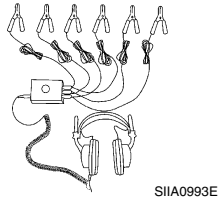

SIA0993E

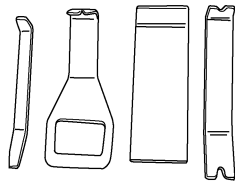

AWJIA0483ZZ



ALJIA1232ZZ

Commercial Service Tools

INFOID:000000012422939

(TechMate No.) Tool name	Description
(J-39565) Engine Ear	Locating the noise

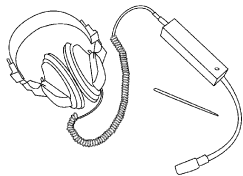

SIA0995E

A
B
C
D
E
F
G
H
I
J
K
MIR
M
N
O
P

SYSTEM

< SYSTEM DESCRIPTION >

	Function	Specifications	
Information display	Current fuel consumption	The last result calculated during normal condition is indicated.	A
	Average fuel consumption		B
	Average vehicle speed		B
	Range (Distance to empty)		B
	Driving distance		B
	Door open warning	The display turns OFF by suspending communication.	C
	Lift gate open warning		D
	Low tire pressure warning		D
	Parking brake release warning		E
	Fuel filler cap warning		E
	Oil pressure warning		E
	CVT warning	An indicated value is maintained at communications blackout.	F
	BSW warning		F
	Odo/trip meter		F
Shift position indicator	The indicator turns OFF by suspending communication.		
Warning lamp/indicator lamp	ABS warning lamp	Turns ON by suspending communication.	G
	Brake warning lamp		H
	EPS warning lamp		H
	VDC warning lamp		H
	AWD warning lamp		H
	Malfunction indicator lamp		I
	Airbag warning lamp		I
	Charge warning lamp	J	
	VDC OFF indicator lamp	Turns OFF by suspending communication.	J
	SPORT mode indicator lamp		K
	AWD LOCK indicator lamp		K
	High beam indicator lamp		L
	Turn signal indicator lamp		L
	Position lamp indicator lamp		L
	OD OFF indicator lamp		M
	BSW indicator lamp		M
	ECO mode indicator lamp		M
Front fog lamp indicator lamp	M		
Hill descent control indicator lamp	M		
Low tire pressure warning lamp	After blinking for 1 minute, the lamp remains ON.	MWI	

SPEEDOMETER

O

P

METER SYSTEM

< WIRING DIAGRAM >

Connector No.	B71
Connector Name	FRONT DOOR SW LH
Connector Color	WHITE

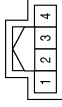

Terminal No.	Color of Wire	Signal Name
3	SB	-

Connector No.	B70
Connector Name	REAR DOOR SWITCH LH
Connector Color	WHITE

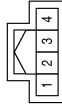

Terminal No.	Color of Wire	Signal Name
3	R	-

Connector No.	B63
Connector Name	JOINT CONNECTOR-B01
Connector Color	GRAY

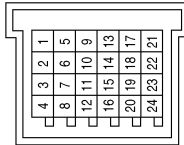

Terminal No.	Color of Wire	Signal Name
3	P	-
4	L	-
7	P	-
8	L	-
11	P	-
12	L	-
13	LAY	-
17	LAY	-
21	SB	-

Connector No.	B87
Connector Name	SEAT BELT BUCKLE SWITCH LH
Connector Color	WHITE



Terminal No.	Color of Wire	Signal Name
1	LAY	-
2	B	-

Connector No.	B78
Connector Name	AIR BAG DIAGNOSIS SENSOR UNIT
Connector Color	YELLOW

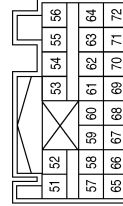

Terminal No.	Color of Wire	Signal Name
67	SB	BUCKLE SW FR LH

Connector No.	B75
Connector Name	AWD CONTROL UNIT
Connector Color	WHITE

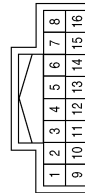

Terminal No.	Color of Wire	Signal Name
8	L	CAN-H
16	P	CAN-L

AANIA3265GB

THE METER CONTROL SWITCH IS INOPERATIVE

< SYMPTOM DIAGNOSIS >

THE METER CONTROL SWITCH IS INOPERATIVE

Description

INFOID:000000012422009

The meter control switches are inoperative when pressed.

Diagnosis Procedure

INFOID:000000012422010

1.CHECK METER CONTROL SWITCH SIGNAL

Check the meter control switch signal. Refer to [MWI-69, "Diagnosis Procedure"](#).

Is the inspection result normal?

YES >> GO TO 2.

NO >> Repair or replace harness or connector.

2.CHECK METER CONTROL SWITCH

Check the meter control switch. Refer to [MWI-70, "Component Inspection"](#).

Is the inspection result normal?

YES >> Replace combination meter. Refer to [MWI-84, "Removal and Installation"](#).

NO >> Replace meter control switch. Refer to [MWI-85, "Removal and Installation"](#).

A
B
C
D
E
F
G
H
I
J
K
L
M
O
P

MWI

DIAGNOSIS SYSTEM (IPDM E/R)

< SYSTEM DESCRIPTION >

[IPDM E/R]

Monitor Item [Unit]	Description
NMB HL (LO) LH CIRC RETRY [0 – 20]	Monitor the number of times that the smart FET in IPDM E/R permits the retry of the headlamp (LO) (left) circuit. NOTE: When the number of short circuits in the headlamp (LO) (left) circuit count is 5 and the ignition switch OFF to ON operation is detected, this item counts 1.
NMB HL (LO) LH CIRC SHORT [0 – 5]	Monitor the number of times that the smart FET in IPDM E/R detects the over current of the headlamp (LO) (left) circuit.
HL (LO) RH CIRC MALFUNCTN [0 – 1]	Monitor the number of times that the smart FET in IPDM E/R reaches the retry upper limit of the headlamp (LO) (right) circuit. NOTE: When the number of headlamp (LO) (right) circuit retries count is 20, this item counts 1.
NMB HL (LO) RH CIRC RETRY [0 – 20]	Monitor the number of times that the smart FET in IPDM E/R permits the retry of the headlamp (LO) (right) circuit. NOTE: When the number of short circuits in the headlamp (LO) (right) circuit count is 5 and the ignition switch OFF to ON operation is detected, this item counts 1.
NMB HL (LO) RH CIRC SHORT [0 – 5]	Monitor the number of times that the smart FET in IPDM E/R detects the over current of the headlamp (LO) (right) circuit.
T LAMP LH CIRC MALFUNCTN [0 – 1]	Monitor the number of times that the smart FET in IPDM E/R reaches the retry upper limit of the tail lamp (left) circuit. NOTE: When the number of tail lamp (left) circuit retries count is 20, this item counts 1.
NMB T LAMP LH CIRC RETRY [0 – 20]	Monitor the number of times that the smart FET in IPDM E/R permits the retry of the tail lamp (left) circuit. NOTE: When the number of short circuits in the tail lamp (left) circuit count is 5 and the ignition switch OFF to ON operation is detected, this item counts 1.
NMB T LAMP LH CIRC SHORT [0 – 5]	Monitor the number of times that the smart FET in IPDM E/R detects the over current of the tail lamp (left) circuit.
T LAMP RH CIRC MALFUNCTN [0 – 1]	Monitor the number of times that the smart FET in IPDM E/R reaches the retry upper limit of the tail lamp (right) circuit. NOTE: When the number of tail lamp (right) circuit retries count is 20, this item counts 1.
NMB T LAMP RH CIRC RETRY [0 – 20]	Monitor the number of times that the smart FET in IPDM E/R permits the retry of the tail lamp (right) circuit. NOTE: When the number of short circuits in the tail lamp (right) circuit count is 5 and the ignition switch OFF to ON operation is detected, this item counts 1.
NMB T LAMP RH CIRC SHORT [0 – 5]	Monitor the number of times that the smart FET in IPDM E/R detects the over current of the tail lamp (right) circuit.
BATTERY STATUS [OK/NG]	Monitor the battery status from the battery output.
BAT DISCHARGE COUNT [0-100]	Indicates condition of battery discharge.
BATTERY STATUS [NG/OK]	Indicates battery status.

A
B
C
D
E
F
G
H
I
J
K
L
PCS
N
O
P

ACTIVE TEST

Test item	Description
HORN	This test is able to check horn operation [Off/On].
FRONT WIPER	This test is able to check wiper motor operation [Off/Low/High].

SYSTEM

POWER DISTRIBUTION SYSTEM

POWER DISTRIBUTION SYSTEM : System Description

INFOID:000000012422820

SYSTEM DIAGRAM

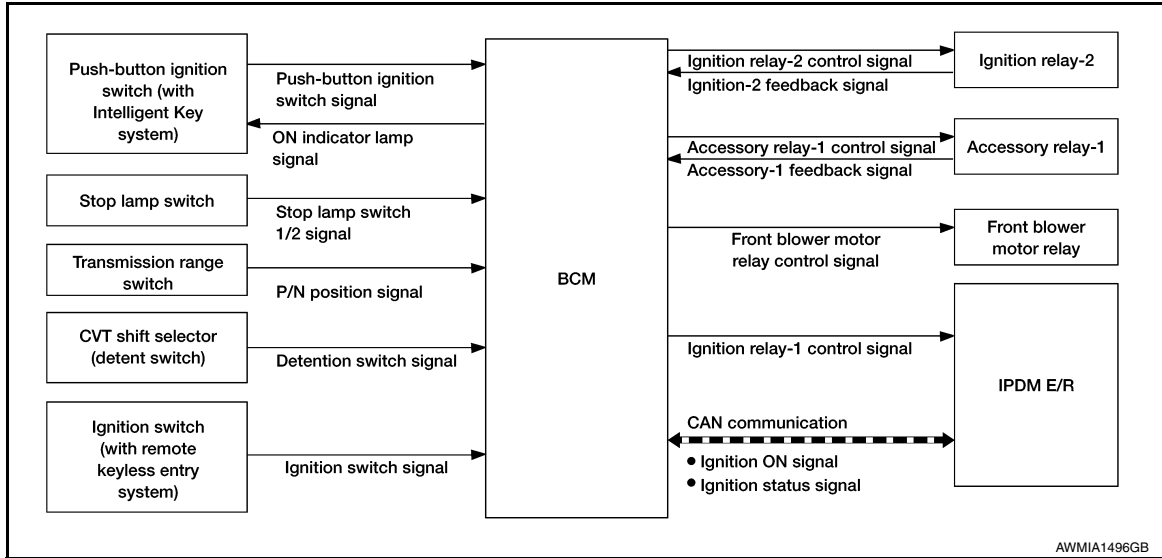

SYSTEM DESCRIPTION

With Intelligent Key System

- PDS (POWER DISTRIBUTION SYSTEM) is the system that the BCM controls with the operation of the push-button ignition switch to perform the power distribution to each power circuit. This system is used instead of the mechanical power supply changing mechanism with the operation of the conventional key cylinder.
- The push-button ignition switch can be operated when Intelligent Key is in the following conditions:
 - Intelligent Key is in the detection area of the inside key antenna.
 - Intelligent Key backside is contacted to push-button ignition switch.
- The push-button ignition switch operation is input to BCM as a signal. BCM changes the power supply position according to the status and operates the following relays to supply power to each power circuit:
 - Ignition relay-1 (IPDM E/R)
 - Ignition relay-2 [fuse block (J/B)]
 - Accessory relay-1
 - Front blower motor relay

NOTE:

- The engine switch operation changes due to the conditions of brake pedal, selector lever and vehicle speed.
- The power supply position can be confirmed with the lighting of the indicator in the push-button ignition switch.

With Remote Keyless Entry System

- PDS (POWER DISTRIBUTION SYSTEM) is the system that the BCM controls with the operation of the ignition switch to perform the power distribution to each power circuit.
- The ignition switch operation is input to the BCM as a signal. BCM changes the power supply position according to the status and operates the following relays to supply power to each power circuit:
 - Ignition relay-1 (IPDM E/R)
 - Ignition relay-2 [fuse block (J/B)]
 - Accessory relay-1
 - Front blower motor relay

IGNITION BATTERY SAVER SYSTEM

When all the following conditions are met for 10 minutes, the ignition battery saver system will cut off the power supply to prevent battery discharge.

- The ignition is in the ON position
- Turn signal lamp is not in operation

B26F2 IGNITION RELAY

[POWER DISTRIBUTION SYSTEM]

< DTC/CIRCUIT DIAGNOSIS >

5. Check continuity between BCM connector M18 and ground.

BCM		Ground	Continuity
Connector	Terminal		
M18	27	—	No

Is the inspection result normal?

- YES >> Replace ignition relay-2.
- NO >> Repair or replace harness or connectors.

4. CHECK IGNITION RELAY-2

Check ignition relay-2. Refer to Refer to [PCS-85, "Component Inspection"](#).

Is the inspection result normal?

- YES >> GO TO 5.
- NO >> Replace ignition relay-2.

5. REPLACE IPDM E/R

1. Replace IPDM E/R. Refer to [PCS-44, "Removal and Installation"](#).
2. Turn ignition switch ON.
3. Perform "Self Diagnostic Result" of "IPDM E/R" using CONSULT.

Is DTC B26F2 detected?

- YES >> Replace BCM. Refer to [PCS-91, "Removal and Installation"](#).
- NO >> Inspection End.

Component Inspection

INFOID:0000000012422848

1. CHECK IGNITION RELAY

1. Turn ignition switch OFF.
2. Remove ignition relay-2.
3. Check continuity between ignition relay terminals.

Terminal		Condition	Continuity
Ignition relay			
3	5	12 V direct current supply between terminals 1 and 2.	Yes
		No current supply	No

Is the inspection result normal?

- YES >> Inspection End.
- NO >> Replace ignition relay-2.

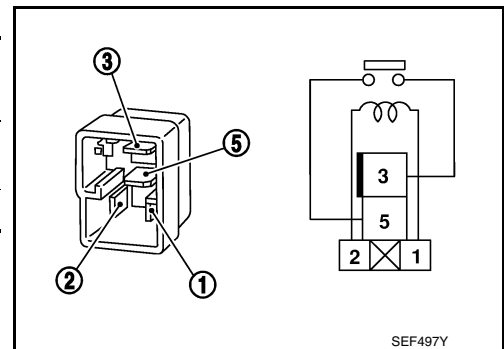

SEF497Y

PCS

INSPECTION AND ADJUSTMENT

< BASIC INSPECTION >

INSPECTION AND ADJUSTMENT

ADDITIONAL SERVICE WHEN REMOVING BATTERY NEGATIVE TERMINAL

ADDITIONAL SERVICE WHEN REMOVING BATTERY NEGATIVE TERMINAL : Description

INFOID:000000012424151

If any of the following work has been done Initial setting is necessary:

- Power supply to the main power window and door lock/unlock switch or power window motor is cut off by the removal of battery terminal or the battery fuse is blown.
- Disconnection and connection of main power window and door lock/unlock switch harness connector.
- Removal and installation of motor from regulator assembly.
- Operation of regulator assembly as an independent unit.
- Removal and installation of glass.
- Removal and installation of door glass run.

The following specified operations can not be performed under the non-initialized condition:

- Auto-up operation
- Anti-pinch function

ADDITIONAL SERVICE WHEN REMOVING BATTERY NEGATIVE TERMINAL : Special Repair Requirement

INFOID:000000012424152

INITIALIZATION PROCEDURE

1. Disconnect battery minus terminal or main power and window door lock/unlock switch connector. Reconnect it after a minute or more.
2. Turn ignition switch ON.
3. Operate power window switch to fully open the window. (This operation is unnecessary if the window is already fully open)
4. Continue pulling the power window switch UP (AUTO-UP operation). Even after glass stops at fully closed position, keep pulling the switch for 2 seconds or more.
5. Initializing procedure is completely.
6. Inspect anti-pinch function.

CHECK ANTI-PINCH FUNCTION

1. Fully open the door window.
 2. Place a piece of wood near fully closed position.
 3. Close door glass completely with AUTO-UP.
- Check that glass lowers for approximately 150 mm (5.9 in) without pinching piece of wood and stops.
 - Check that glass does not rise when operating the main power and door lock/unlock switch while lowering.

CAUTION:

- **Perform initial setting when auto-up operation or anti-pinch function does not operate normally.**
- **Check that AUTO-UP operates before inspection when system initialization is performed.**
- **Do not check with hands and other body parts because they may be pinched. Do not get pinched.**
- **It may switch to fail-safe mode if open/close operation is performed continuously without full close. Perform initial setting in that situation. Refer to [BCS-47, "Fail Safe"](#)**
- **Finish initial setting. Otherwise, next operation cannot be done.**

1. Auto-up operation
2. Anti-pinch function

ADDITIONAL SERVICE WHEN REPLACING CONTROL UNIT

ADDITIONAL SERVICE WHEN REPLACING CONTROL UNIT : Description

INFOID:000000012424153

Refer to [PWC-28, "ADDITIONAL SERVICE WHEN REMOVING BATTERY NEGATIVE TERMINAL : Description"](#).

ADDITIONAL SERVICE WHEN REPLACING CONTROL UNIT : Special Repair Re-

AUTO OPERATION DOES NOT OPERATE BUT MANUAL OPERATE NORMALLY (DRIVER SIDE)

< SYMPTOM DIAGNOSIS >

AUTO OPERATION DOES NOT OPERATE BUT MANUAL OPERATE NORMALLY (DRIVER SIDE)

Diagnosis Procedure

INFOID:000000012424209

1.PERFORM INITIALIZATION PROCEDURE

Initialization procedure is executed and operation is confirmed.

Refer to [PWC-28. "ADDITIONAL SERVICE WHEN REMOVING BATTERY NEGATIVE TERMINAL : Special Repair Requirement"](#).

Is the inspection result normal?

YES >> Inspection End.

NO >> GO TO 2.

2.CHECK ENCODER

Check encoder.

Refer to [PWC-46. "Component Function Check"](#).

Is the inspection result normal?

YES >> GO TO 3.

NO >> Repair or replace the malfunctioning parts.

3.CONFIRM THE OPERATION

Confirm the operation again.

Is the result normal?

YES >> Check intermittent incident. Refer to [GI-45. "Intermittent Incident"](#).

NO >> GO TO 1.

A
B
C
D
E
F
G
H
I
J
L
M
N
O
P

PWC

REAR DRIVE SHAFT

< UNIT DISASSEMBLY AND ASSEMBLY >

[AWD]

ASSEMBLY

Final Drive Side

1. Install new boot and new small boot band to shaft.

CAUTION:

- Cover drive shaft serration with tape (A) to prevent damage to boot during installation.
- Do not reuse boot or boot band.

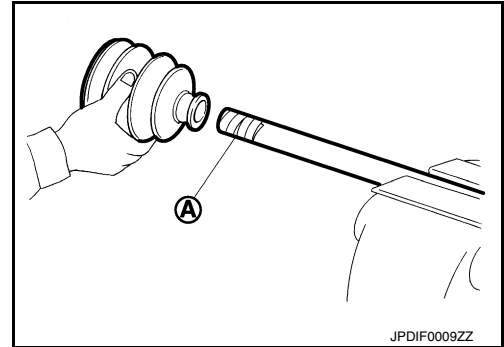

2. Remove the tape wrapped around the serration on shaft.
3. Align the matching marks (A) on the spider assembly (1) with the matching mark on the shaft (2). Install the spider assembly to the shaft with the chamfer (B) facing the shaft.

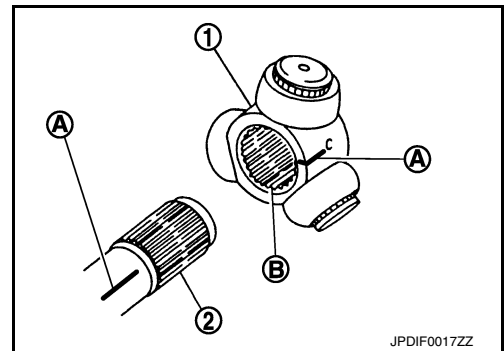

4. Install new snap ring (1) using suitable tool onto shaft.

CAUTION:

Do not reuse snap ring.

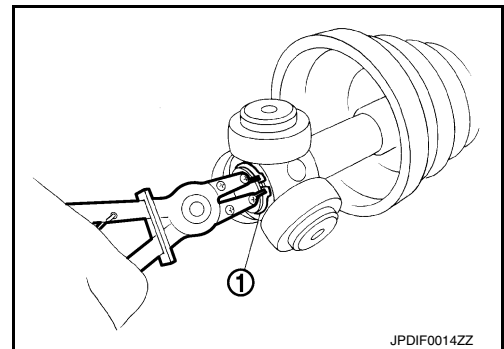

5. Apply the appropriate amount of grease (Genuine NISSAN Grease) onto the spider assembly and the sliding surface of the slide joint housing.
NOTE:
Always check with the Parts Department for the latest parts information.
6. Install the slide joint housing onto the spider assembly and apply the balance of the specified amount of grease (Genuine NISSAN Grease) into the slide joint housing.

Grease quantity : Refer to [RAX-27, "Drive Shaft"](#).

NOTE:

Always check with the Parts Department for the latest parts information.

7. Align the matching mark on the slide joint housing with the matching mark on the shaft.

POWER SUPPLY AND GROUND CIRCUIT

< DTC/CIRCUIT DIAGNOSIS >

1. CHECK POWER SUPPLY

1. Turn ignition switch OFF.
2. Disconnect sunshade motor assembly connector.
3. Turn ignition switch ON.
4. Check voltage between sunshade motor assembly harness connector and ground.

(+)		(-)	Voltage (Approx.)
Sunshade motor assembly			
Connector	Terminal	Ground	Battery voltage
R5	3		

Is the inspection result normal?

YES >> GO TO 2.

NO >> GO TO 3.

2. CHECK GROUND CIRCUIT

1. Turn ignition switch OFF.
2. Check continuity between sunshade motor assembly harness connector and ground.

Sunshade motor assembly		Ground	Continuity
Connector	Terminal		
R5	1		Yes

Is the inspection result normal?

YES >> GO TO 4.

NO >> Repair or replace the harness.

3. CHECK HARNESS CONTINUITY

1. Turn ignition switch OFF.
2. Disconnect power window relay connector.
3. Check continuity between power window relay harness connector and moonroof motor assembly harness connector.

Power window relay		Moonroof motor assembly		Continuity
Connector	Terminal	Connector	Terminal	
M58	3	R4	3	Yes

4. Check continuity between power window relay harness connector and ground.

Power window relay		Ground	Continuity
Connector	Terminal		
M58	3		No

Is the inspection result normal?

YES >> Refer to [PWC-49. "Diagnosis Procedure"](#).

NO >> Repair or replace harness.

SUNSHADE

< UNIT DISASSEMBLY AND ASSEMBLY >

8. Manually disengage the sunshade motor and moonroof motor assembly using a suitable tool then remove both sunshade cables and glass lid cables by pulling rearward.
9. Remove the cable guides (LH/RH) by pulling rearward from the moonroof unit tracks.

ASSEMBLY

CAUTION:

Do not remove the sunshade retainer pin or damage may occur.

1. Insert the sunshade and glass lid cables guides by sliding forward on the moonroof unit track.
2. Assembly moonroof unit bases (2) (LH/RH) by pushing forward on the moonroof unit tracks (1) (LH/RH).

NOTE:

RH side shown; LH similar.

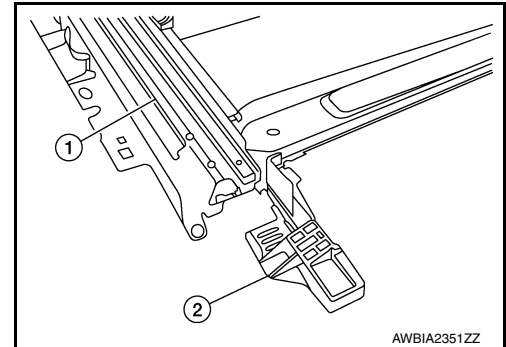

3. Insert sunshade black hem (3) and under upper unit guide (2) on the moonroof unit bases (1) (LH/RH).

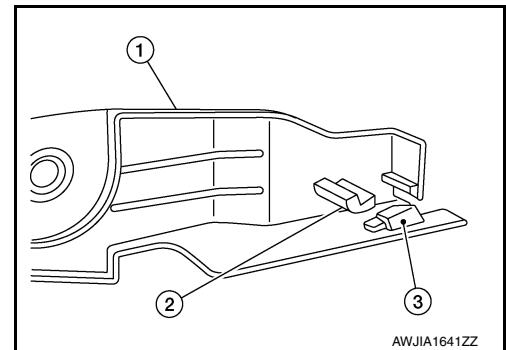

- (1) Sunshade black hem.
- (2) Sunshade fabric.

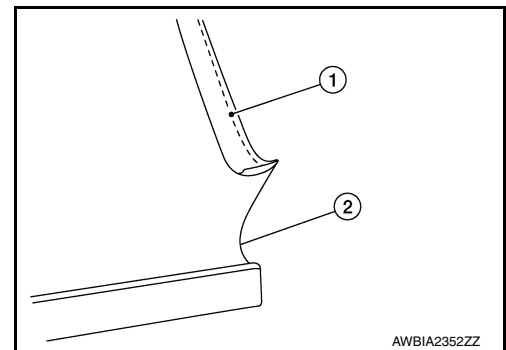

4. Assemble the sunshade by applying pressure towards the drivers and inserting both ends into the moonroof unit bases (LH/RH).

COIL SPRING

< REMOVAL AND INSTALLATION >

10. Loosen the lower link nut at the rear suspension member. Remove the lower link bolt and nut from the rear suspension arm. Separate the lower link from the rear suspension arm. Refer to [RSU-17, "Exploded View"](#).
11. Separate the brake tube from the rear suspension arm. Refer to [BR-24, "REAR : Exploded View"](#).
12. Slowly lower the suitable jack supporting the rear suspension arm. Remove the upper seat, the coil spring and the lower seat.

INSPECTION AFTER REMOVAL

Check lower link, bushing and coil spring for deformation, crack, and damage. Replace components if necessary.

INSTALLATION

1. Align the lower seat indentations (C) with rear suspension arm grooves (B). Install the lower seat protrusion (A) into the hole in the rear suspension arm.

CAUTION:

The lower rubber seat protrusion must be securely inserted into the hole of rear suspension arm.

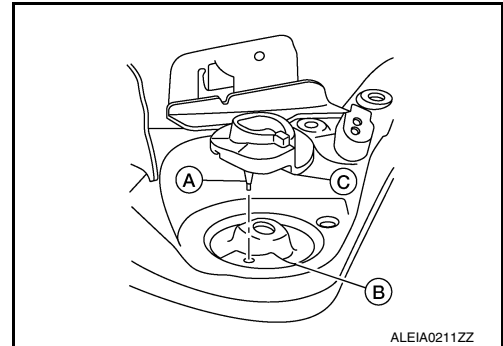

2. Identify the upper side of the coil spring.

NOTE:

- The top of the coil spring has a flat shape.
- The paint identification mark (A) is 1.75 turns from the bottom of the coil spring.

⇐ : Upper side

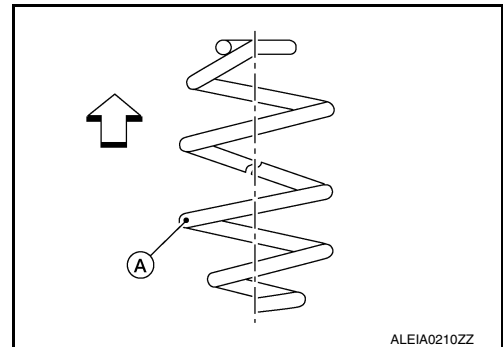

3. Align the coil spring (1) to the lower seat (2). Install coil spring to lower seat.

Maximum distance (A) : 5mm (0.20 in)

CAUTION:

Assemble coil spring so that spring lower end is located in the spring end holding section of lower rubber seat.

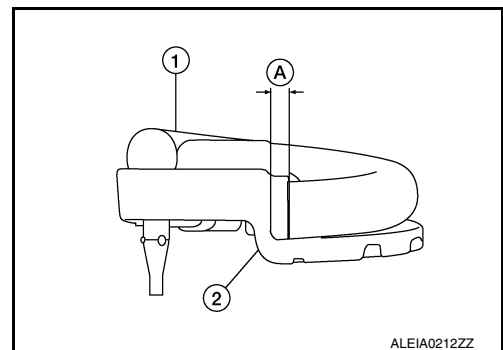

Download Complete manual for FREE @ <https://www.heydownloads.com>

LATCH (LOWER ANCHORS AND TETHER FOR CHILDREN) SYSTEM

< REMOVAL AND INSTALLATION >

LATCH (LOWER ANCHORS AND TETHER FOR CHILDREN) SYSTEM

Removal and Installation

INFOID:000000012424942

The LATCH (Lower Anchors and Tether for CHildren) system is not serviceable.

- A
- B
- C
- D
- E
- F
- G
- SB**
- I
- J
- K
- L
- M
- N
- O
- P

FRONT SEAT

< REMOVAL AND INSTALLATION >

- | | | |
|----------------------------|--|------------------------------|
| 22. Seat belt buckle | 23. Seat cushion rear finisher (LH) | 24. Seat cushion frame |
| 25. Seatback assembly | 26. Seatback bracket [LH (USA production)] | 27. Headrest holder (locked) |
| 28. Headrest holder (free) | | |

MANUAL SEAT

SEC. 870

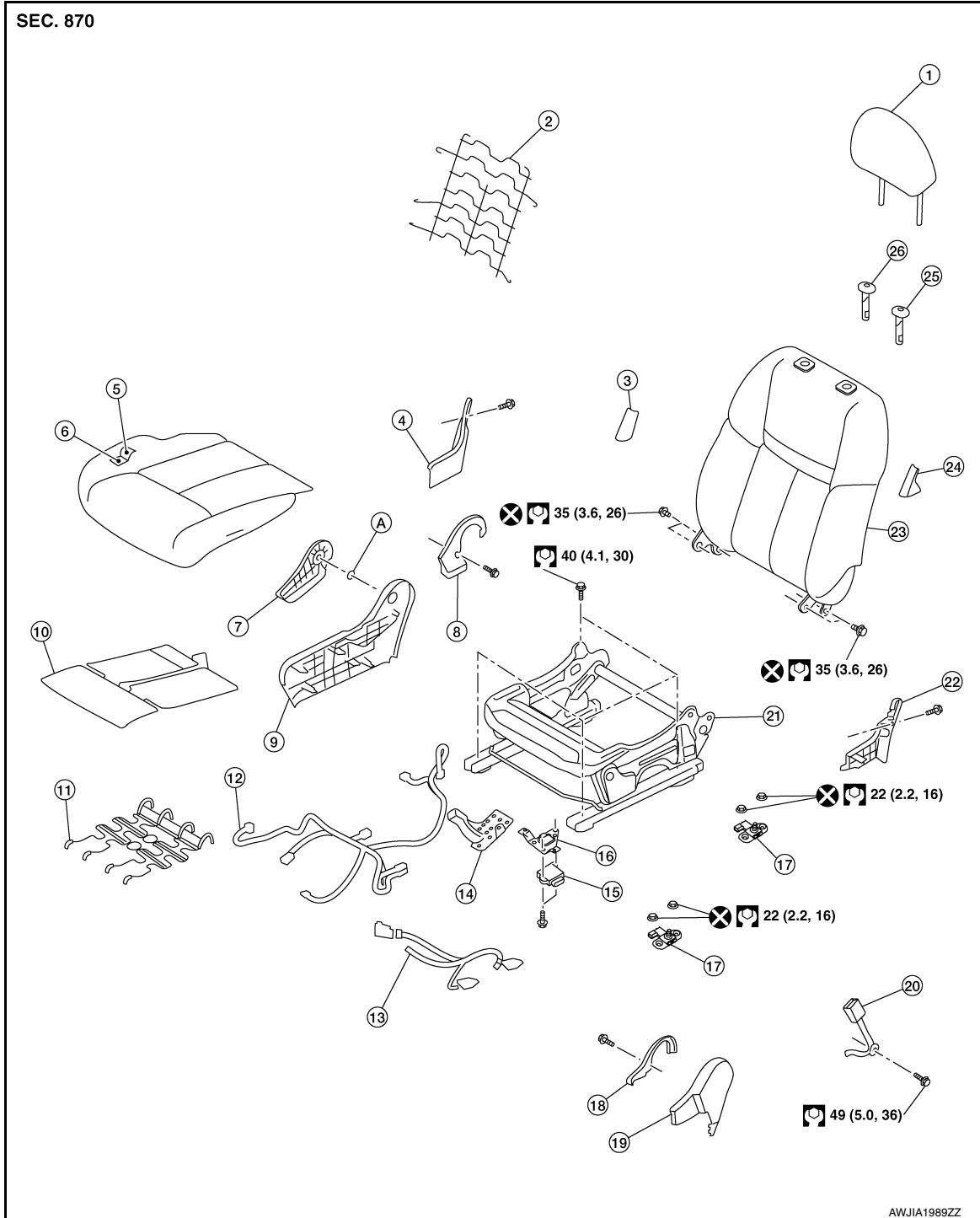

AWJJA1989ZZ

- | | | |
|------------------------------------|-------------------------------------|-------------------------------------|
| 1. Headrest | 2. Seatback support | 3. Seatback bracket (RH) |
| 4. Seat cushion rear finisher (RH) | 5. Seat cushion trim | 6. Seat cushion pad |
| 7. Recline lever | 8. Seat cushion inner finisher (RH) | 9. Seat cushion outer finisher (RH) |

SECOND ROW SEAT

< UNIT DISASSEMBLY AND ASSEMBLY >

4. Remove screw (A), then using a suitable tool release clips and pawls and remove seat cushion outside finisher (LH).

△: Clip
○: Pawl

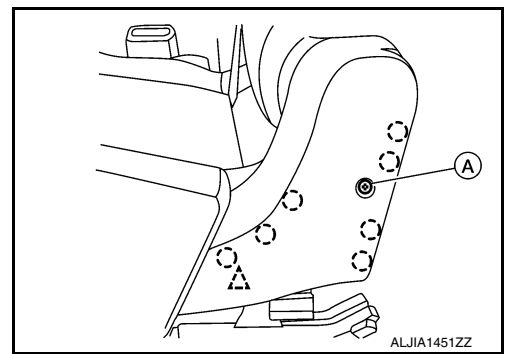

5. Using a suitable tool, release clips and pawls, then remove seat cushion outer finisher (RH)

△: Clip
○: Pawl

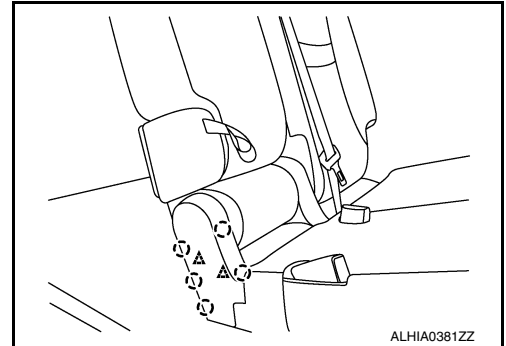

6. Remove bolts (A) and seatback frame.

NOTE:

Seatback pad and trim removed for clarity.

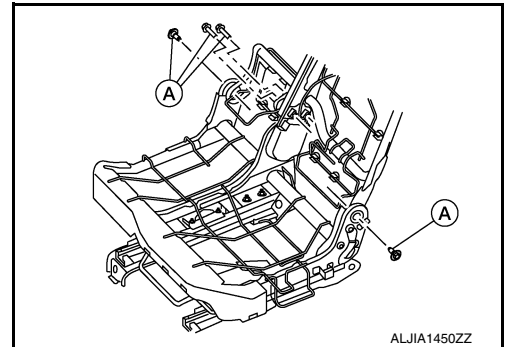

7. Release J-hooks (A) and fasteners (B), then route seatbelt buckles through seat cushion and remove seat cushion pad and seat cushion trim.

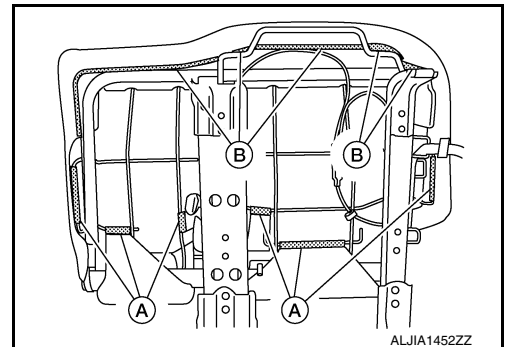

A
B
C
D
E
F
G
H
I
SE
K
L
M
N
O
P

DIAGNOSIS SYSTEM (BCM)

[WITH INTELLIGENT KEY SYSTEM]

< SYSTEM DESCRIPTION >

DIAGNOSIS SYSTEM (BCM)

COMMON ITEM

COMMON ITEM : CONSULT Function (BCM - COMMON ITEM)

INFOID:0000000012567349

APPLICATION ITEM

CONSULT performs the following functions via CAN communication with BCM.

Direct Diagnostic Mode	Description
Ecu Identification	The BCM part number is displayed.
Self Diagnostic Result	The BCM self diagnostic results are displayed.
Data Monitor	The BCM input/output data is displayed in real time.
Active Test	The BCM activates outputs to test components.
Work support	The settings for BCM functions can be changed.
Configuration	<ul style="list-style-type: none"> The vehicle specification can be read and saved. The vehicle specification can be written when replacing BCM.
CAN Diag Support Mntr	The result of transmit/receive diagnosis of CAN communication is displayed.

SYSTEM APPLICATION

BCM can perform the following functions.

System	Sub System	Direct Diagnostic Mode						
		Ecu Identification	Self Diagnostic Result	Data Monitor	Active Test	Work support	Configuration	CAN Diag Support Mntr
Door lock	DOOR LOCK		x	x	x	x		
Rear window defogger	REAR DEFOGGER			x	x	x		
Warning chime	BUZZER			x	x			
Interior room lamp timer	INT LAMP			x	x	x		
Exterior lamp	HEADLAMP			x	x	x		
Wiper and washer	WIPER			x	x	x		
Turn signal and hazard warning lamps	FLASHER			x	x			
Intelligent Key system	INTELLIGENT KEY		x	x	x	x		
Combination switch	COMB SW			x				
BCM	BCM	x	x			x	x	x
Immobilizer	IMMU		x	x	x			
Interior room lamp battery saver	BATTERY SAVER			x	x			
Back door open	TRUNK			x				
Vehicle security system	THEFT ALM			x	x	x		
RAP system	RETAINED PWR			x				
Signal buffer system	SIGNAL BUFFER			x				
Air conditioner	AIR CONDITIONER				x			

INTELLIGENT KEY

A
B
C
D
E
F
G
H
I
J
L
M
N
O
P

SEC

B2557 VEHICLE SPEED

< DTC/CIRCUIT DIAGNOSIS >

[WITH INTELLIGENT KEY SYSTEM]

B2557 VEHICLE SPEED

DTC Logic

INFOID:0000000012423983

DTC DETECTION LOGIC

NOTE:

- If DTC B2557 is displayed with DTC U1000, first perform the trouble diagnosis for DTC U1000. Refer to [BCS-65, "DTC Logic"](#).
- If DTC B2557 is displayed with DTC U1010, first perform the trouble diagnosis for DTC U1010. Refer to [BCS-66, "DTC Logic"](#).

DTC No.	Trouble diagnosis name	DTC detecting condition	Possible causes
B2557	VEHICLE SPEED	BCM detects one of the following conditions for 10 seconds continuously. <ul style="list-style-type: none">• Vehicle speed signal from combination meter is 10 km/h (6.2 MPH) or more, and vehicle speed signal from ABS actuator and electric unit (control unit) is 4 km/h (2.5 MPH) or less.• Vehicle speed signal from combination meter is 4 km/h (2.5 MPH) or less, and vehicle speed signal from ABS actuator and electric unit (control unit) is 10 km/h (6.2 MPH) or more.	<ul style="list-style-type: none">• Harness or connectors (The CAN communication line is open or shorted.)• Combination meter• ABS actuator and electric unit (control unit)

DTC CONFIRMATION PROCEDURE

1. PERFORM DTC CONFIRMATION PROCEDURE

1. Start engine and wait 10 seconds or more.
2. Drive the vehicle at a vehicle speed of 10 km/h (6.2 MPH) or more for 10 seconds or more.
3. Check DTC in "Self Diagnostic Result" of "BCM" using CONSULT.

Is DTC detected?

- YES >> GO TO [SEC-89, "Diagnosis Procedure"](#).
NO >> Inspection End.

Diagnosis Procedure

INFOID:0000000012423984

1. CHECK DTC OF "ABS ACTUATOR AND ELECTRIC UNIT (CONTROL UNIT)"

Check DTC in "Self Diagnostic Result" of "ABS" using CONSULT.

Is DTC detected?

- YES >> Perform the trouble diagnosis related to the detected DTC. Refer to [BRC-57, "DTC Index"](#).
NO >> GO TO 2.

2. CHECK DTC OF "COMBINATION METER"

Check DTC in "Self Diagnostic Result" of "METER/M&A" using CONSULT.

Is DTC detected?

- YES >> Perform the trouble diagnosis related to the detected DTC. Refer to [MWI-31, "DTC Index"](#).
NO >> GO TO 3.

3. CHECK INTERMITTENT INCIDENT

Refer to [GI-45, "Intermittent Incident"](#).

>> Inspection End.

COMPONENT PARTS

< SYSTEM DESCRIPTION >

[WITHOUT INTELLIGENT KEY SYSTEM]

SYSTEM DESCRIPTION

COMPONENT PARTS

Component Parts Location

INFOID:000000012424035

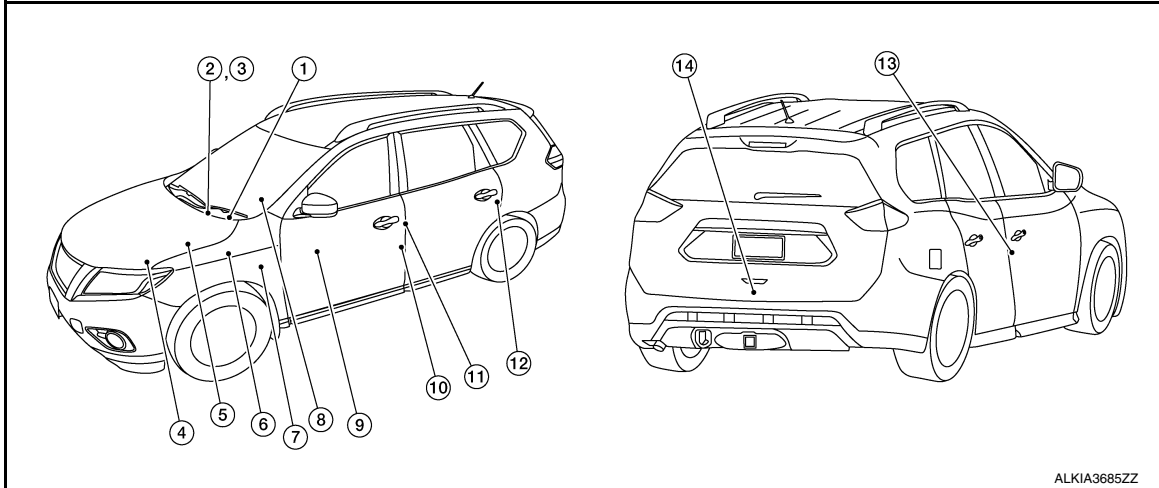

No.	Component	Function
1.	Combination meter	Combination meter transmits the vehicle speed signal to BCM via CAN communication. BCM also receives the vehicle speed signal from ABS actuator and electric unit (control unit) via CAN communication. BCM compares both signals to detect the vehicle speed. Security indicator lamp is located on combination meter. Security indicator lamp blinks when ignition switch is in any position other than ON to warn that NISSAN VEHICLE IMMOBILIZER SYSTEM-NATS [NVIS (NATS)] is on board. Refer to MWI-6, "METER SYSTEM : Component Parts Location" .
2.	Ignition switch	Ignition switch transmits ON/OFF signal to BCM. BCM changes the ignition switch position with the operation of ignition switch.
3.	NATS antenna amp.	Refer to SEC-125, "NATS Antenna Amp."
4.	Transmission range switch	Refer to TM-14, "CVT CONTROL SYSTEM : Transmission Range Switch" .
5.	IPDM E/R	Refer to PCS-6, "Component Parts Location" .
6.	Stop lamp switch	Refer to BRC-12, "Stop Lamp Switch" .
7.	BCM	BCM controls NISSAN VEHICLE IMMOBILIZER SYSTEM-NATS [NVIS (NATS)] and VEHICLE SECURITY SYSTEM. Then, when the ignition switch is turned ON, BCM performs ID verification between BCM and ECM. If the ID verification result is OK, ECM can start engine. Refer to BCS-80, "BODY CONTROL SYSTEM : Component Parts Location" for detailed installation location.
8.	CVT shift selector	Refer to TM-20, "SHIFT LOCK SYSTEM : Component Parts Location" .
9.	Main power window and door lock/unlock switch	Door lock and unlock switch is integrated into the main power window and door lock/unlock switch. Door lock and unlock switch transmits door lock/unlock operation signal to BCM. Refer to PWC-7, "Main Power Window And Door Lock/Unlock Switch" .
10.	Front door lock assembly LH	Door key cylinder switch is integrated into front door lock assembly (driver side). Door key cylinder switch detects door LOCK/UNLOCK operation using mechanical key, and then transmits the operation signal to BCM. Refer to DLK-296, "Front Door Lock Assembly (Driver Side)" .

VEHICLE SECURITY SYSTEM

[WITHOUT INTELLIGENT KEY SYSTEM]

< WIRING DIAGRAM >

Connector No.	B71
Connector Name	FRONT DOOR SWITCH LH
Connector Color	WHITE

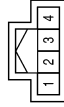

Terminal No.	Color of Wire	Signal Name
3	SB	-

Connector No.	B70
Connector Name	REAR DOOR SWITCH LH
Connector Color	WHITE

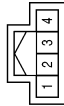

Terminal No.	Color of Wire	Signal Name
3	R	-

Connector No.	B63
Connector Name	JOINT CONNECTOR-B01
Connector Color	GRAY

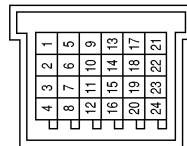

Terminal No.	Color of Wire	Signal Name
3	P	-
4	L	-
7	P	-
8	L	-

Connector No.	B142
Connector Name	REAR DOOR SWITCH RH
Connector Color	WHITE



Terminal No.	Color of Wire	Signal Name
3	W	-

Connector No.	B141
Connector Name	FRONT DOOR SWITCH RH
Connector Color	WHITE

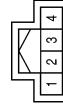

Terminal No.	Color of Wire	Signal Name
3	GR	-

Connector No.	B140
Connector Name	WIRE TO WIRE
Connector Color	WHITE

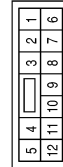

Terminal No.	Color of Wire	Signal Name
6	GR	-
10	W	-

AAKIA2450GB

A
B
C
D
E
F
G
H
I
J
L
M
N
O
P

SEC

B27D2 START CUT RELAY ON

< DTC/CIRCUIT DIAGNOSIS >

[WITHOUT INTELLIGENT KEY SYSTEM]

Component Inspection

INFOID:000000012424093

1. CHECK STARTER CUT RELAY

1. Turn ignition switch OFF.
2. Disconnect starter cut relay.
3. Check continuity between starter cut relay terminals.

Starter cut relay		Condition	Continuity
Terminal			
3	5	12 V direct current supply between terminals 1 and 2	Yes
		No current supply	No

Is the inspection result normal?

- YES >> Inspection End.
NO >> Replace starter cut relay.

AIR BAG DIAGNOSIS SENSOR UNIT

< REMOVAL AND INSTALLATION >

- Replace the air bag diagnosis sensor unit if it has been dropped or sustained an impact.
- Do not strike the air bag diagnosis sensor unit.

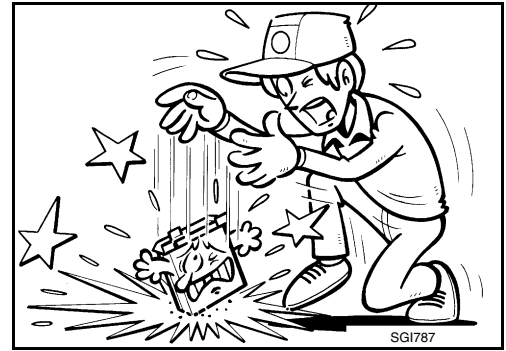

INSTALLATION

CAUTION:

Be sure to perform "After Replace ECU" of "Read / Write Configuration" or "Manual Configuration" when replacing air bag diagnosis sensor unit. Refer to [SRC-41, "CONFIGURATION : Description"](#). Installation is in the reverse order of removal.

CAUTION:

- Do not reuse the air bag diagnosis sensor unit bolt and nuts.
- The air bag diagnosis sensor unit must always be installed with the label arrow mark "←" pointing toward the front of the vehicle for proper operation.
- Do not damage the air bag diagnosis sensor unit harness connectors during installation.
- After installation is complete, check that no system malfunction is detected causing the air bag warning lamp to illuminate.
- If a malfunction is indicated by the air bag warning lamp after repair or replacement of the malfunctioning parts, perform the SRS final check. Refer to [SRC-16, "Trouble Diagnosis with CONSULT"](#).
- After replacing the air bag diagnosis sensor unit, confirm using CONSULT that the ECU discriminated number (identification number) or part number of the new replacement air bag diagnosis sensor unit matches the ECU discriminated number (identification number) or part number of the replaced (old) air bag diagnosis sensor unit.

NOTE:

If the ECU discriminated number or part number of the new replacement air bag diagnosis sensor unit differs from the ECU discriminated number or part number of the replaced air bag diagnosis sensor unit, reconfirm the parts information and verify that the correct air bag diagnosis sensor unit was installed.

DIAGNOSIS SENSOR UNIT

< ECU DIAGNOSIS INFORMATION >

Flashes (Primary)	Flash Length (seconds)	Flashes (Secondary)	Malfunctioning Component or Circuit	Reference
2	3	1	Crash zone sensor	SRC-74. "Diagnosis Procedure"
		2	Front side air bag satellite sensor LH	SRC-65. "Diagnosis Procedure"
		3	Front side air bag satellite sensor RH	SRC-77. "Diagnosis Procedure"
		4	Rear side satellite sensor LH	SRC-68. "Diagnosis Procedure"
		5	Rear side satellite sensor RH	SRC-80. "Diagnosis Procedure"
		6	Front door satellite sensor LH	SRC-71. "Diagnosis Procedure"
		7	Front door satellite sensor RH	SRC-83. "Diagnosis Procedure"
		8	Seat belt buckle switch LH	SRC-93. "Diagnosis Procedure"
		9	Seat belt buckle switch RH	SRC-95. "Diagnosis Procedure"

B0028 SIDE AIRBAG MODULE RH

< DTC/CIRCUIT DIAGNOSIS >

Diagnosis Procedure

INFOID:000000012589579

1. HARNESS CONNECTOR

Visually inspect all applicable harness connectors for the following:

- Visible damage to connector or terminal
- Loose terminal
- Poor connection

NOTE:

All harness connectors should be inspected from the air bag diagnosis sensor unit to the end component (including any in-line connectors).

Is the inspection result normal?

YES >> GO TO 2.

NO >> Perform one of the following repairs:

- Visible damage: Replace the harness.
- Loose terminal: Secure the terminal.
- Poor connection: Secure the connection.

2. CONFIRM DTC

1. Reconnect all harness connectors.
2. Turn ignition switch ON.
3. Check for DTC using CONSULT.

Is DTC still current?

YES >> GO TO 3.

NO >> Refer to [GI-45, "Intermittent Incident"](#).

3. WIRING HARNESS

Check the wiring harness for visible damage.

NOTE:

The entire wiring harness should be inspected from the air bag diagnosis sensor unit to the end component (including any in-line connectors).

Is the inspection result normal?

YES >> GO TO 4.

NO >> Replace the harness.

4. CONFIRM DTC

1. Reconnect all harness connectors.
2. Turn ignition switch ON.
3. Check for DTC using CONSULT.

Is DTC still current?

YES >> GO TO 5.

NO >> Refer to [GI-45, "Intermittent Incident"](#).

5. AIR BAG DIAGNOSIS SENSOR UNIT

1. Replace the air bag diagnosis sensor unit. Refer to [SR-26, "Removal and Installation"](#).
2. Turn ignition switch ON.
3. Check for DTC using CONSULT.

Is DTC still current?

YES >> GO TO 6.

NO >> Clear DTC. Inspection End.

6. SIDE AIR BAG MODULE RH

1. Replace the side air bag module RH. Refer to [SR-21, "Removal and Installation"](#).
2. Turn ignition switch ON.
3. Check for DTC using CONSULT.

Is DTC still current?

YES >> GO TO 7.

NO >> Clear DTC. Inspection End.

A

B

C

D

E

F

G

SRC

I

J

K

L

M

N

O

P

B1428 SEAT BELT BUCKLE SWITCH LH

< DTC/CIRCUIT DIAGNOSIS >

- Poor connection

NOTE:

All harness connectors should be inspected from the air bag diagnosis unit to the end component (including any in-line connectors).

Is the inspection result normal?

YES >> GO TO 2.

- NO >> Perform one of the following repairs:
- Visible damage: Replace the harness.
 - Loose terminal: Secure the terminal.
 - Poor connection: Secure the connection.

2. CONFIRM DTC

1. Reconnect all harness connectors.
2. Turn ignition switch ON.
3. Check for DTC using CONSULT.

Is DTC still current?

YES >> GO TO 3

NO >> Refer to [GI-45, "Intermittent Incident"](#).

3. WIRING HARNESS

Check the wiring harness for visible damage.

NOTE:

The entire wiring harness should be inspected from the air bag diagnosis sensor unit to the end component (including any in-line connectors).

Is the inspection result normal?

YES >> GO TO 4.

NO >> Replace the harness.

4. CONFIRM DTC

1. Reconnect all harness connectors.
2. Turn ignition switch ON.
3. Check for DTC using CONSULT.

Is DTC still current?

YES >> GO TO 5.

NO >> Refer to [GI-45, "Intermittent Incident"](#).

5. SEAT BELT BUCKLE SWITCH LH

1. Replace the seat belt buckle switch LH. Refer to [SR-29, "Removal and Installation"](#).
2. Turn ignition switch ON.
3. Check for DTC using CONSULT.

Is DTC still current?

YES >> GO TO 6.

NO >> Clear DTC. Inspection End.

6. AIR BAG DIAGNOSIS SENSOR UNIT

1. Replace the air bag diagnosis sensor unit. Refer to [SR-26, "Removal and Installation"](#).
2. Turn ignition switch ON.
3. Check for DTC using CONSULT.

Is DTC still current?

YES >> GO TO 7.

NO >> Clear DTC. Inspection End.

7. RELATED HARNESS

Replace the related harness.

>> **END**

STEERING COLUMN

< REMOVAL AND INSTALLATION >

STEERING COLUMN

Exploded View

INFOID:000000012426139

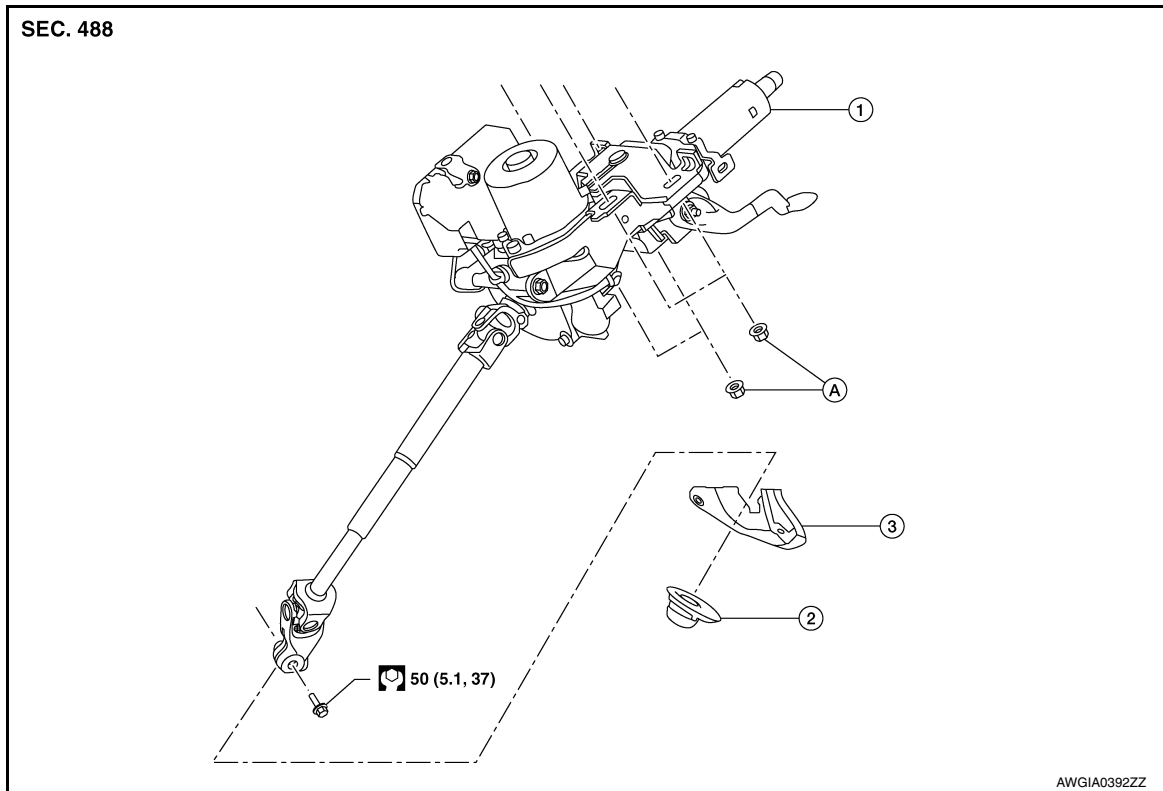

1. Steering column
 2. Lower cover seal
 3. Column hole cover
- A. Refer to INSTALLATION

Removal and Installation

INFOID:000000012426140

CAUTION:

- Any time the ignition switch has been disconnected, removed or installed, the keys must be re-registered in the BCM.
- Do not cause impact to the steering column during removal and installation.

REMOVAL

1. Set front wheels and tires in the straight-ahead position.
2. Place the tilt to the highest level.
3. Remove instrument lower panel LH. Refer to [IP-23, "Removal and Installation"](#).
4. Remove the knee protector. Refer to [IP-14, "Exploded View"](#).
5. Remove steering wheel. Refer to [ST-11, "Removal and Installation"](#).
6. Remove steering column covers. Refer to [IP-18, "Removal and Installation"](#).
7. Disconnect the harness connector from the combination switch.
8. Disconnect the harness connector from the spiral cable.
9. Disconnect the harness connector from the steering angle sensor.
10. Disconnect the harness connector from the ignition switch.
11. Disconnect the harness connector from the key switch.
12. Disconnect the harness connector from the NATS antenna amp.
13. For models without intelligent key system, perform the following steps to separate key interlock cable from steering lock unit:

C1601 BATTERY POWER SUPPLY

< DTC/CIRCUIT DIAGNOSIS >

DTC/CIRCUIT DIAGNOSIS

C1601 BATTERY POWER SUPPLY

DTC Logic

INFOID:0000000012426167

DTC DETECTION LOGIC

DTC	Display item	Malfunction detected condition	Possible cause
C1601	BATTERY VOLT	When a power supply voltage to the EPS control unit is maintained at 18.2 V or more or at less than 9 V continuously for five second or more.	<ul style="list-style-type: none">• Harness or connector• EPS control unit• Fuse• Power supply system• Battery

DTC CONFIRMATION PROCEDURE

1. PRECONDITIONING

If "DTC CONFIRMATION PROCEDURE" has been previously conducted, always turn ignition switch OFF and wait at least 10 seconds before conducting the next test.

>> GO TO 2.

2. DTC REPRODUCTION PROCEDURE

With CONSULT

1. Turn the ignition switch OFF to ON.
2. Perform "Self Diagnostic Result" of "EPS".

Is DTC "C1601" detected?

- YES >> Proceed to diagnosis procedure. Refer to [STC-20, "Diagnosis Procedure"](#).
NO >> Inspection End.

Diagnosis Procedure

INFOID:0000000012426168

Regarding Wiring Diagram information, refer to [STC-14, "Wiring Diagram"](#).

1. CHECK EPS CONTROL UNIT GROUND CIRCUIT

1. Turn ignition switch OFF.
2. Disconnect EPS control unit harness connector.
3. Check continuity between EPS control unit harness connector terminal and ground.

EPS control unit		—	Continuity
Connector	Terminal		
M48	10	Ground	Yes

4. Connect EPS control unit harness connector.

Is the inspection result normal?

- YES >> GO TO 2.
NO >> Repair open circuit or short to ground or short to power in harness or connectors.

2. CHECK EPS CONTROL UNIT POWER SUPPLY CIRCUIT (1)

1. Check voltage between EPS control unit harness connector terminals and ground.

B TERMINAL CIRCUIT

< DTC/CIRCUIT DIAGNOSIS >

- YES >> "B" terminal circuit is OK. Further inspection is necessary. Refer to [STR-11, "Work Flow \(With GR8-1200 NI\)"](#) or [STR-15, "Work Flow \(Without GR8-1200 NI\)"](#).
- NO >> Check the starter motor case to engine mounting for high resistance.

SYSTEM

< SYSTEM DESCRIPTION >

[CVT: RE0F10D]

SYSTEM CVT CONTROL SYSTEM CVT CONTROL SYSTEM : System Description

INFOID:000000012428058

SYSTEM DIAGRAM

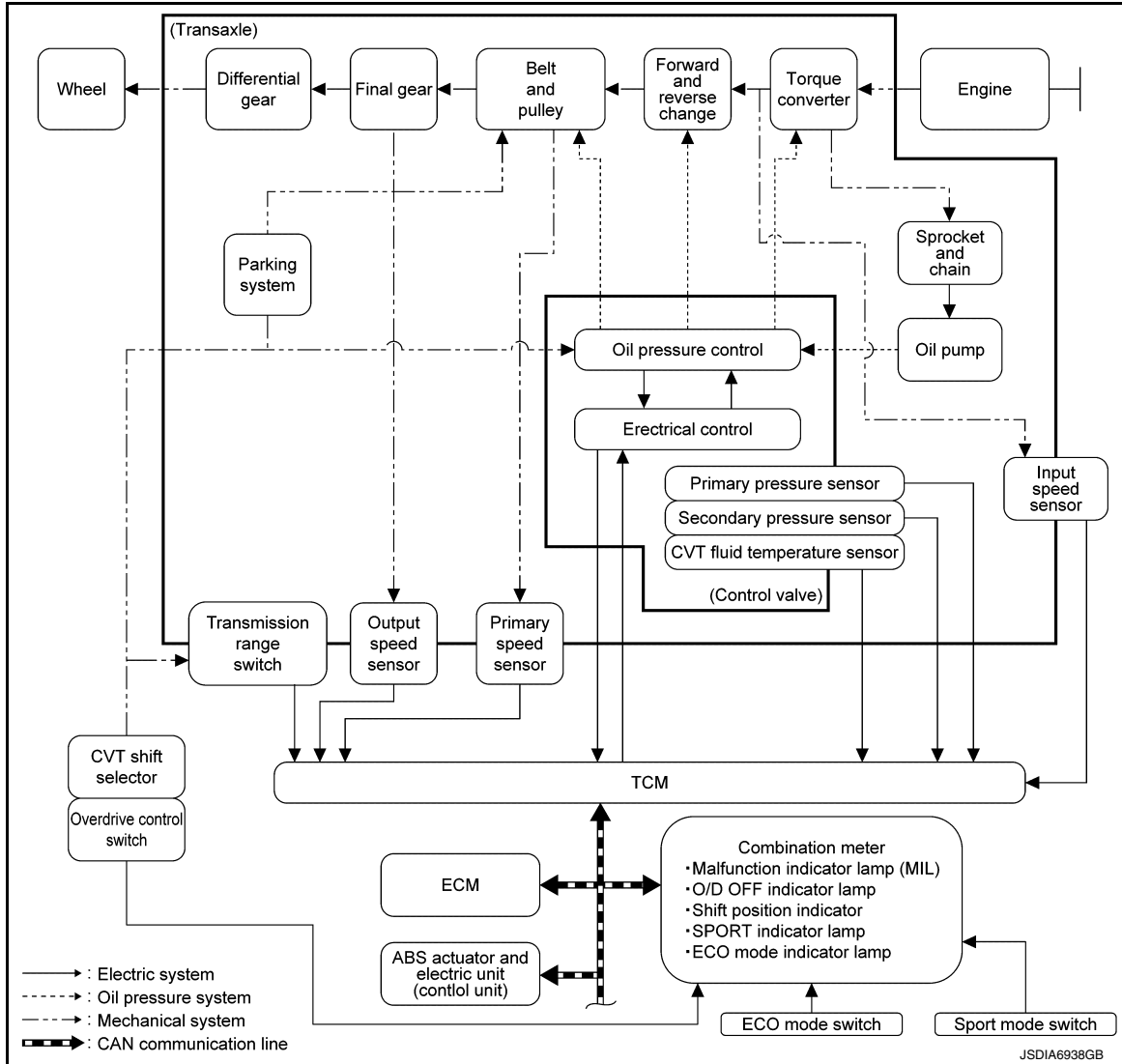

MAIN CONTROL CONTENTS OF TCM

Controls	Reference
Line pressure control	TM-36, "LINE PRESSURE CONTROL : System Description"
Shift control	TM-37, "SHIFT CONTROL : System Description"
Select control	TM-39, "SELECT CONTROL : System Description"
Lock-up control	TM-40, "LOCK-UP CONTROL : System Description"
Sport mode control	TM-41, "SPORT MODE CONTROL : System Description"
ECO mode control	TM-43, "ECO MODE SYSTEM : System Description"
Fail-safe	TM-58, "Fail-safe"
Self-diagnosis function	TM-47, "CONSULT Function"
Communication function with CONSULT	TM-47, "CONSULT Function"

LIST OF CONTROL ITEMS AND INPUT/OUTPUT

U1000 CAN COMM CIRCUIT

Description

INFOID:000000012428109

CAN (Controller Area Network) is a serial communication line for real-time application. It is an on-vehicle multiplex communication line with high data communication speed and excellent malfunction detection ability. Many electronic control units are equipped onto a vehicle, and each control unit shares information and links with other control units during operation (not independently). In CAN communication, control units are connected with 2 communication lines (CAN-H line, CAN-L line) allowing a high rate of information transmission with less wiring. Each control unit transmits/receives data but selectively reads required data only.

DTC Description

INFOID:000000012428110

CAN (Controller Area Network) is a serial communication line for real-time application. It is an on-vehicle multiplex communication line with high data communication speed and excellent malfunction detection ability. Many electronic control units are equipped onto a vehicle, and each control unit shares information and links with other control units during operation (not independently). In CAN communication, control units are connected with 2 communication lines (CAN-H line, CAN-L line) allowing a high rate of information transmission with less wiring. Each control unit transmits/receives data but selectively reads required data only.

DTC DETECTION LOGIC

DTC	CONSULT screen terms (Trouble diagnosis content)	DTC detection condition
U1000	CAN COMM CIRCUIT (CAN Communication Line)	When the ignition switch is ON, TCM cannot send the CAN communication signal continuously for 2 seconds or more.

POSSIBLE CAUSE

Harness or connector (CAN communication line is open or shorted)

FAIL-SAFE

Not changed from normal driving

DTC CONFIRMATION PROCEDURE

1. PREPARATION BEFORE WORK

If another "DTC CONFIRMATION PROCEDURE" occurs just before, turn ignition switch OFF and wait for at least 10 seconds, then perform the next test.

>> GO TO 2.

2. CHECK DTC DETECTION

With CONSULT

1. Start the engine and wait for at least 5 seconds.
2. Check the DTC.

Is "U1000" detected?

YES >> Go to [TM-101, "Diagnosis Procedure"](#).

NO-1 >> To check malfunction symptom before repair: Refer to [GI-45, "Intermittent Incident"](#).

NO-2 >> Confirmation after repair: INSPECTION END

Diagnosis Procedure

INFOID:000000012428111

For the diagnosis procedure, refer to [LAN-20, "Trouble Diagnosis Flow Chart"](#).

P0746 PRESSURE CONTROL SOLENOID A

< DTC/CIRCUIT DIAGNOSIS >

[CVT: RE0F10D]

P0746 PRESSURE CONTROL SOLENOID A

DTC Description

INFOID:000000012428143

DTC DETECTION LOGIC

DTC	CONSULT screen terms (Trouble diagnosis content)	DTC detection condition
P0746	PC SOLENOID A (Pressure Control Solenoid A Performance/ Stuck Off)	The detecting condition A or detection condition B is detected twice or more (1 second or more later after detection of the first) in the same DC under the following diagnosis conditions: <ul style="list-style-type: none">• Diagnosis conditions<ul style="list-style-type: none">- Engine speed: More than 600 rpm- Primary pulley speed: More than 450 rpm- Idle is not being detected.- Acceleration/deceleration speed: -0.49 m/s^2 (-0.05 G) or more- The primary pulley speed experienced 300 rpm or more and the secondary pulley speed experienced 250 rpm or more at least once.- Secondary pulley speed: More than 150 rpm- TCM power supply voltage: More than 11 V• Detection condition A<ul style="list-style-type: none">- Status with the shifting ratio of the primary pulley speed/secondary pulley ratio exceeding 2.981 is 0.2 sec. or more continuously.• Detection condition B<ul style="list-style-type: none">- Status with the shifting ratio of the primary pulley speed/secondary pulley ratio exceeding 3.781 is 0.1 sec. or more continuously.

NOTE:

DC stands for "DRIVING CYCLE" and indicates a series of driving cycle of "Ignition switch OFF → ON → driving → OFF".

POSSIBLE CAUSE

- Line pressure solenoid valve
- Control valve assembly

FAIL-SAFE

- Selector shock is large
- Start is slow
- Acceleration is slow
- Lock-up is not performed

DTC CONFIRMATION PROCEDURE

CAUTION:

Be careful of the driving speed.

1. PREPARATION BEFORE WORK

If another "DTC CONFIRMATION PROCEDURE" occurs just before, turn ignition switch OFF and wait for at least 10 seconds, then perform the next test.

>> GO TO 2.

2. CHECK DTC DETECTION

1. Start the engine.
2. Drive the vehicle.
3. Maintain the following conditions for 10 seconds or more.

Selector lever : "D" position
Accelerator pedal position : 0.5/8 or more
Vehicle speed : 40 km/h (25 MPH) or more

4. Stop the vehicle.
5. Check the first trip DTC.

P2814 SELECT SOLENOID

< DTC/CIRCUIT DIAGNOSIS >

[CVT: RE0F10D]

P2814 SELECT SOLENOID

DTC Description

INFOID:000000012428179

DTC DETECTION LOGIC

DTC	CONSULT screen terms (Trouble diagnosis content)	DTC detection condition
P2814	SELECT SOLENOID (Select solenoid)	When all of the following conditions are satisfied and this state is maintained for 0.48 seconds: <ul style="list-style-type: none"> • TCM power supply voltage: 11 V or more • TCM judges that solenoid valve circuit is shorted to ground.

POSSIBLE CAUSE

- Harness or connector (Select solenoid valve circuit shorted to ground)
- Select solenoid valve

FAIL-SAFE

Selector shock is large

DTC CONFIRMATION PROCEDURE

CAUTION:

Be careful of the driving speed.

1. PREPARATION BEFORE WORK

If another "DTC CONFIRMATION PROCEDURE" occurs just before, turn ignition switch OFF and wait for at least 10 seconds, then perform the next test.

>> GO TO 2.

2. CHECK DTC DETECTION

1. Start the engine.
2. Maintain the following conditions. (Keep 5 seconds or more after the selector lever shifted.)

Selector lever : N → D, N → R, P → R

3. Check the first trip DTC.

Is "P2814" detected?

YES >> Go to [TM-171, "Diagnosis Procedure"](#).

NO-1 >> To check malfunction symptom before repair: Refer to [GI-45, "Intermittent Incident"](#).

NO-2 >> Confirmation after repair: INSPECTION END

Diagnosis Procedure

INFOID:000000012428180

1. CHECK CIRCUIT BETWEEN TCM AND CVT UNIT

1. Turn ignition switch OFF.
2. Disconnect TCM connector and CVT unit connector.
3. Check continuity between TCM harness connector terminal and ground.

TCM		—	Continuity
Connector	Terminal		
F75	37	Ground	Not existed

Is the inspection result normal?

YES >> GO TO 2.

NO >> Repair or replace damaged parts.

2. CHECK CIRCUIT BETWEEN CVT UNIT AND GROUND

Check continuity between CVT unit harness connector terminal and ground.

OIL PAN

< REMOVAL AND INSTALLATION >

[CVT: RE0F10D]

3. Tighten the oil pan bolts in the order shown to the specified torque.

← : Front

4. Tighten the oil pan bolts again clockwise from (1) shown to the specified torque.

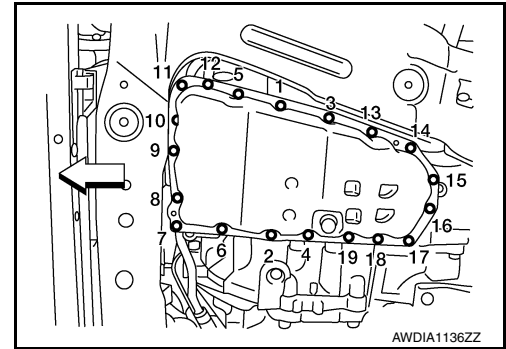

INFOID:000000012428215

Inspection

INSPECTION AFTER REMOVAL

Check oil pan for foreign material.

- If a large amount of worn material is found, clutch plate may be worn.
 - If iron powder is found, bearings, gears, or clutch plates may be worn.
 - If aluminum powder is found, bushing may be worn, or chips or burrs of aluminum casting parts may enter.
- Check points where wear is found in all cases.

INSPECTION AFTER INSTALLATION

Check the CVT fluid level and leakage. Refer to [TM-189, "Inspection"](#).

DUCTS AND GRILLES

< REMOVAL AND INSTALLATION >

1. Remove front pillar finishers (LH/RH). Refer to [INT-20, "FRONT PILLAR FINISHER : Removal and Installation"](#).
2. Release defroster grille clips using a suitable tool.
3. Remove defroster grille.

INSTALLATION

Installation is in the reverse order of removal.

CENTER VENTILATOR GRILLE

CENTER VENTILATOR GRILLE : Removal and Installation

INFOID:0000000012424703

REMOVAL

1. Release the pawls using a suitable tool and remove center ventilator grille from instrument panel.

⊖: Pawl

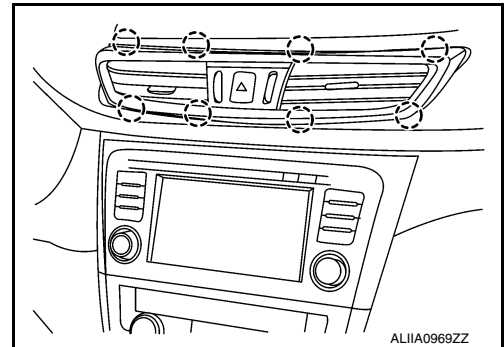

2. Disconnect the harness connector (A) from hazard switch (1).

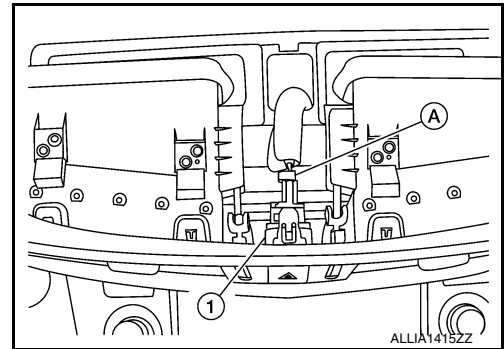

INSTALLATION

Installation is in the reverse order of removal.

SIDE VENTILATOR GRILLE

SIDE VENTILATOR GRILLE : Removal and Installation

INFOID:0000000012424704

REMOVAL

Side ventilator grille (LH)

A
B
C
D
E
F
G
H
VTL
J
K
L
M
N
O
P

WARNING CHIME SYSTEM

< WIRING DIAGRAM >

WIRING DIAGRAM

WARNING CHIME SYSTEM

Wiring Diagram

INFOID:000000012422038

: WITH INTELLIGENT KEY SYSTEM
 : WITHOUT INTELLIGENT KEY SYSTEM

WARNING CHIME SYSTEM

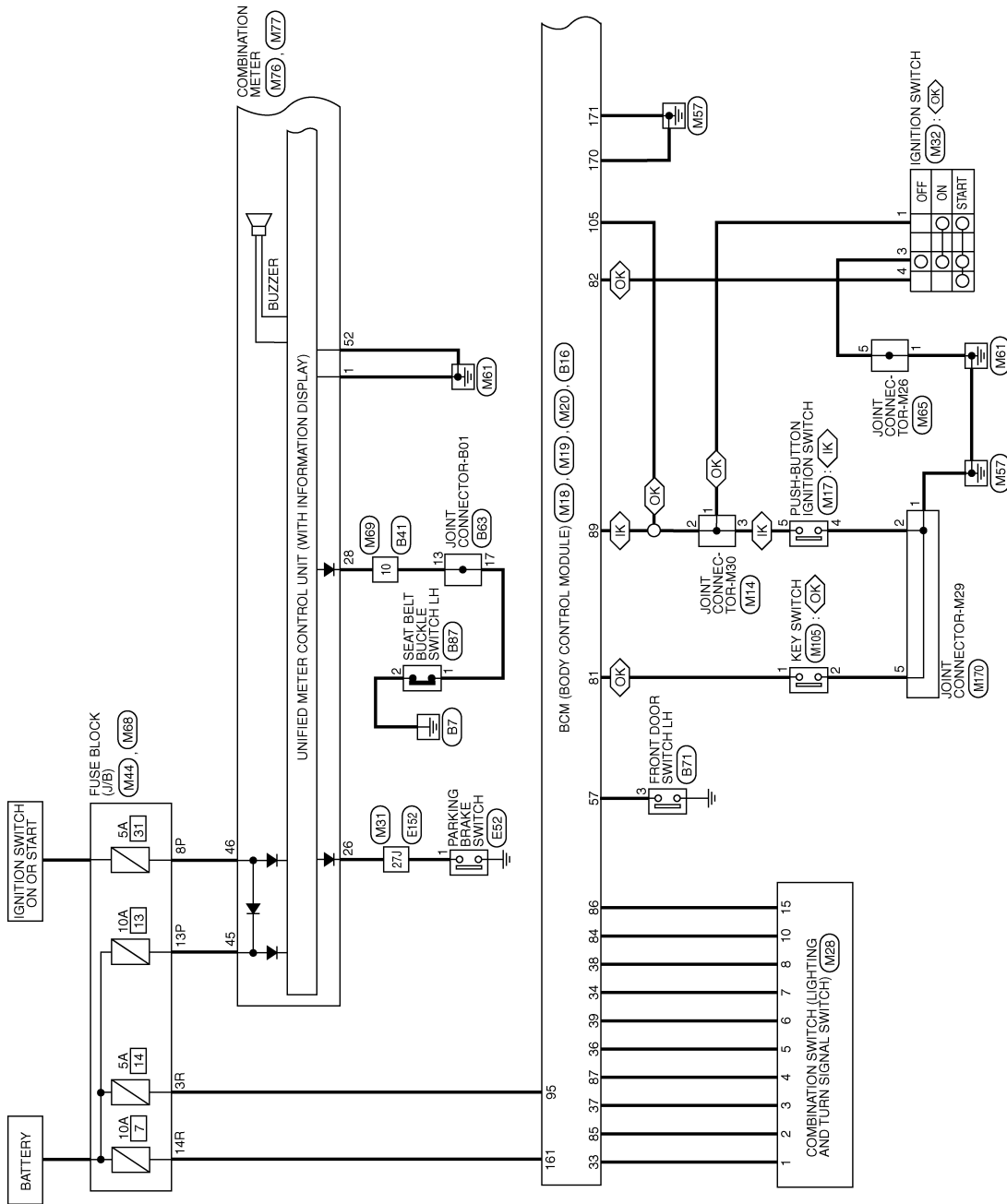

AANWA1442GB

DIAGNOSIS SYSTEM (COMBINATION METER)

< SYSTEM DESCRIPTION >

DIAGNOSIS SYSTEM (COMBINATION METER)

Description

INFOID:000000012572218

COMBINATION METER SELF-DIAGNOSIS MODE

The following meter functions can be checked during Combination Meter Self-Diagnosis Mode:

- Pointer sweep of speedometer, tachometer and gauges.
- Illumination of all LCD segments and color patterns for meter displays.
- Illumination of all lamps/LEDs that are controlled by the combination meter (regardless of switch status).

STARTING COMBINATION METER SELF-DIAGNOSIS MODE

NOTE:

- Check combination meter power supply and ground circuits if self-diagnosis mode does not start. Refer to [WCS-39, "COMBINATION METER : Diagnosis Procedure"](#). Replace combination meter if power supply and ground circuits are found to be normal and self-diagnosis mode does not start. Refer to [MWI-84, "Removal and Installation"](#).
- Combination meter self-diagnosis mode will function with the ignition switch in ON. Combination meter self-diagnosis mode will exit upon turning the ignition switch to OFF.

How to Initiate Self-Diagnosis Mode

1. Turn ignition switch OFF.
2. While pressing the trip reset switch (1), turn ignition switch ON.
3. Keep the trip reset switch for 1 seconds or more.
4. Press the trip reset switch at least 3 times. (Within 7 seconds after the ignition switch is turned ON.)
5. "Work instruction code" is indicated in the top portion of information display and self-diagnosis is started.
6. The mode switches in the order shown below each time the trip reset switch is pressed.

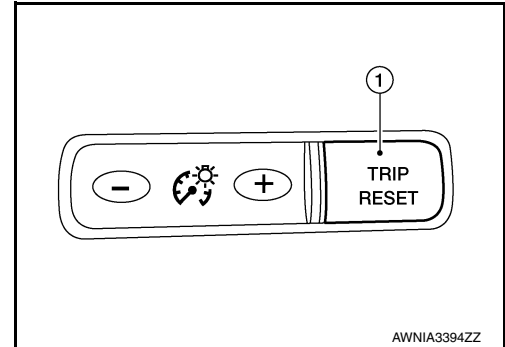

NOTE:

If the trip reset switch is not operated for 20 seconds or more, the self-diagnosis mode is automatically cancelled.

Test order	Test item	Description
1	Work instruction code	This item is displayed, but not used.
2	Part number	
3	Software code	
4	EEPROM code	
5	Hardware code	
6	P.C.B code	
7	Circuit check	<p>The pointer of the following items moves from 0 to MAX twice.</p> <ul style="list-style-type: none"> • Speedometer • Tachometer • Engine coolant temperature gauge • Fuel gauge <p>NOTE: If any one of the pointers does not sweep, replace combination meter.</p>
8	Color check ^{*1}	Performs the color check of the information display.

KEY SWITCH SIGNAL CIRCUIT (WITHOUT INTELLIGENT KEY)

< DTC/CIRCUIT DIAGNOSIS >

KEY SWITCH SIGNAL CIRCUIT (WITHOUT INTELLIGENT KEY)

Description

INFOID:000000012422053

Transmits a key switch signal to the BCM.

Component Function Check

INFOID:000000012422054

1. CHECK BCM INPUT SIGNAL

Select "Data Monitor" of "BCM" using CONSULT and check the "KEY SW" monitor value.

Monitor Item	Condition	Status
KEY SW	When key is removed from key cylinder	OFF
	When key is inserted into key cylinder	ON

Is the inspection result normal?

YES >> Inspection End.

NO >> Refer to [WCS-47, "Diagnosis Procedure"](#).

Diagnosis Procedure

INFOID:000000012422055

Regarding Wiring Diagram information, refer to [WCS-30, "Wiring Diagram"](#).

1. CHECK BCM INPUT SIGNAL

Check voltage between BCM harness connector M19 terminal 81 and ground.

BCM		Ground	Condition	Voltage (Approx.)
Connector	Terminal			
M19	81	—	Key is inserted	Battery voltage
			Key is removed	0V

Is the inspection result normal?

YES >> Inspection End.

NO >> GO TO 2.

2. CHECK KEY SWITCH CIRCUIT

1. Disconnect BCM connector M19 and key switch connector M105.
2. Check continuity between BCM harness connector M19 terminal 81 and key switch harness connector M105 terminal 1.

BCM		Key switch		Continuity
Connector	Terminal	Connector	Terminal	
M19	81	M105	1	Yes

WCS

3. Check continuity between BCM harness connector M19 terminal 81 and ground.

BCM		Ground	Continuity
Connector	Terminal		
M19	81	—	No

Is the inspection result normal?

YES >> GO TO 3.

NO >> Repair or replace harness or connector.

Download Complete manual for FREE @ <https://www.heydownloads.com>

CONFIGURATION (TIRE PRESSURE MONITORING SYSTEM)

< BASIC INSPECTION >

CONFIGURATION (TIRE PRESSURE MONITORING SYSTEM)

Work Procedure

INFOID:000000012427690

CAUTION:

- After configuration, perform the following:
 - Turn the ignition switch from OFF to ON and check that the low tire pressure warning lamp turns OFF after staying illuminated for approximately two seconds.
 - Perform tire pressure sensor ID registration. Refer to [WT-26, "Work Procedure"](#).
- If TPMS configuration is not completed, TPMS transmitter ID registration will not complete.

1. CHECKING ECU IDENTIFICATION NUMBER

CONSULT

1. Select "ECU Identification" of "BCM".
2. Write down ECU part number.

>> GO TO 2.

2. RE/PROGRAMMING, CONFIGURATION

CONSULT

1. Select "Re/programming, Configuration" from home screen.
2. Check box confirming the precautions have been read.
3. Select "Next".

Is "Manual Selection (Vehicle Name)" displayed?

- YES >> GO TO 3.
NO >> GO TO 4.

3. VEHICLE SELECTION

CONSULT

1. Select Vehicle Make, Vehicle Name, and correct model year.
2. Press "Select".

>> GO TO 4.

4. VEHICLE CONFIRMATION

CONSULT

1. Verify VIN or Chassis Number matches the vehicles VIN.
2. Select "Confirm".

>> GO TO 5.

5. INPUT VIN

1. Verify VIN number in dialog box matches vehicles VIN.
2. Select "Confirm".

>> GO TO 6.

6. SYSTEM SELECTION

CONSULT

Select "AIR PRESSURE MONITOR".

>> GO TO 7.

7. OPERATION SELECTION

1. Select "Manual Configuration"
2. Select the DATA PART NO. that matches the BCM part number written down in step 1.
3. Select "Next".

WHEEL AND TIRE

< PERIODIC MAINTENANCE >

WHEEL AND TIRE

Adjustment

INFOID:000000012427737

BALANCING WHEELS (ADHESIVE WEIGHT TYPE)

Preparation Before Adjustment

Remove inner and outer balance weights from the wheel. Using releasing agent, remove double-faced adhesive tape from the wheel and tire.

CAUTION:

- Be careful not to scratch the wheel and tire during removal.
- After removing double-faced adhesive tape, wipe clean all traces of releasing agent from the wheel and tire.

Wheel Balance Adjustment

CAUTION:

- DO NOT use center hole cone-type clamping machines to hold the wheel during tire removal/installation or balancing or damage to the wheel paint, cladding or chrome may result. Use only rim-type or universal lug-type clamping machines to hold the wheel during servicing.
- If a balancer machine has an adhesive weight mode setting, select the adhesive weight mode setting and skip Step 2 below. If a balancer machine only has the clip-on (rim flange) weight mode setting, follow Step 2 to calculate the correct size adhesive weight.

1. Set wheel and tire on balancer machine using the center hole as a guide. Start the balancer machine.
2. For balancer machines that only have a clip-on (rim flange) weight mode setting, follow this step to calculate the correct size adhesive weight to use. When inner and outer imbalance values are shown on the balancer machine indicator, multiply outer imbalance value by 5/3 (1.67) to determine balance weight that should be used. Select the outer balance weight with a value closest to the calculated value above and install in to the designated outer position of or at the designated angle in relation to the wheel and tire.

- a. Indicated imbalance value $\times 5/3$ (1.67) = balance weight to be installed

Calculation example:

$23 \text{ g (0.81 oz)} \times 5/3 (1.67) = 38.33 \text{ g (1.35 oz)} \Rightarrow 40 \text{ g (1.41 oz)}$
balance weight (closer to calculated balance weight value)

NOTE:

Note that balance weight value must be closer to the calculated balance weight value.

Example:

$37.4 \Rightarrow 35 \text{ g (1.23 oz)}$

$37.5 \Rightarrow 40 \text{ g (1.41 oz)}$

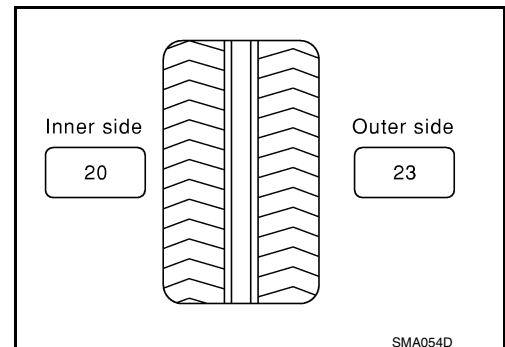

DIAGNOSIS SYSTEM (IPDM E/R)

< SYSTEM DESCRIPTION >

Monitor Item [Unit]	Description	
HEADLAMP (HI) RH [%]	Indicates condition of headlamp high beam RH.	A
HEADLAMP (LO) LH [%]	Indicates condition of headlamp low beam LH.	
HEADLAMP (LO) RH [%]	Indicates condition of headlamp low beam RH.	B
A/C RELAY STUCK [NG/OK]	Indicates condition of A/C relay.	
A/C RELAY [Off/On]	Indicates condition of A/C relay.	
COMP ECV STATUS [NG/OK]	Indicates condition of A/C compressor.	C
VEHICLE SECURITY HORN [Off/On]	Indicates condition of horn relay.	
BATTERY CURRENT SENSOR [NG/OK]	Indicates condition of battery current sensor.	D
FRONT FOG LAMP [Off/On]	Indicates condition of front fog lamps.	
COMP ECV CURRENT [A]	Indicates condition of A/C compressor current.	
BATTERY VOLTAGE [V]	Indicates condition of battery voltage.	E
COOLING FAN DUTY [%]	Indicates condition of cooling fans.	
HOOD SW (CAN) [OPEN/CLOSE]	Indicates condition of hood switch.	F
FRONT WIPER [STOP/LOW/HIGH]	Indicates condition of front wiper motor.	
FR WIPER STOP POSITION [STOP P/ACTIVE P]	Indicates condition of front wiper motor stop.	
HEADLAMP (HI) [Off/On]	Indicates condition of headlamp high beams.	G
HEADLAMP (LO) [Off/On]	Indicates condition of headlamp low beams.	
IGNITION RELAY STATUS [Off/On]	Indicates condition of ignition relay-1.	
IGN RELAY MONITOR [Off/On]	Indicates condition of ignition relay-1 feedback.	H
IGNITION POWER SUPPLY [Off/On]	Indicates condition of ignition relay-1.	
INTERLOCK/PNP SW (CAN) [Off/On]	Indicates condition of transmission range switch P (Park) and N (Neutral) positions.	I
PUSH-BUTTON IGN SW (CAN) [Off/On]	Indicates condition of push-button ignition switch.	
TAIL LAMP [Off/On]	Indicates condition of tail lamps.	J
REVERSE SIGNAL (CAN) [Off/On]	Indicates condition of transmission range switch R (Reverse) position.	
ST&ST CONT RELAY STATUS [Off/ST R On]	Indicates condition of starter cut and starter relays.	K
STARTER MOTOR STATUS [Off/On]	Indicates condition of starter motor.	
STARTER RELAY (CAN) [LOW/HIGH]	Indicates condition of starter relay.	WW
IPDM NOT SLEEP [NO RDY/RDY]	Indicates condition of IPDM E/R sleep status.	
AFTER COOLING TIME [No request/Request]	Indicates condition of cooling fan request.	
AFTER COOLING SPEED [%]	Indicates condition of cooling fans.	M
COOLING FAN TYPE [NISSAN/RENAULT]	Indicates cooling fan type.	
COMPRESSOR REQ1 [Off/On]	Indicates condition of A/C compressor request.	
VHCL SECURITY HORN REQ [Off/On]	Indicates condition of horn relay request.	N
DTRL REQ [Off/On]	Indicates condition of daytime running light request.	
SLEEP/WAKE UP [WAKEUP/SLEEP]	Indicates condition of IPDM E/R sleep/wake.	O
CRANKING ENABLE-TCM [NG/OK]	Indicates condition of crank enable from TCM.	
CRANKING ENABLE-ECM [NG/OK]	Indicates condition of crank enable from ECM.	
CAN DIAGNOSIS [NG/OK]	Indicates condition of CAN diagnosis.	P
FRONT FOG LAMP REQ [Off/On]	Indicates condition of front fog lamp request.	
HIGH BEAM REQ [Off/On]	Indicates condition of headlamp high beam request.	
HORN CHIRP [Off/On]	Indicates condition of horn relay request.	
COOLING FAN REQ [%]	Indicates condition of cooling fan request.	
ENGINE STATUS [STOP/RUN/IDLING]	Indicates condition of engine status.	

CLICK HERE TO **DOWNLOAD** THE COMPLETE MANUAL

- Thank you very much for reading the preview of the manual.
- You can download the complete manual from: www.heydownloads.com by clicking the link below



- Please note: If there is no response to CLICKING the link, please download this PDF first and then click on it.

CLICK HERE TO **DOWNLOAD** THE COMPLETE MANUAL