

Edition: August 2015
Revision: August 2015
Pub No. SM16EA0D40U0

NISSAN FRONTIER

MODEL D40 SERIES

All rights reserved. No part of this Service Manual may be reproduced or stored in a retrieval system, or transmitted in any form, or by any means, electronic, mechanical, photo-copying, recording or otherwise, without the prior written permission of Nissan North America, Inc.

QUICK REFERENCE INDEX

A GENERAL INFORMATION	GI General Information
B ENGINE	EM Engine Mechanical
	LU Engine Lubrication System
	CO Engine Cooling System
	EC Engine Control System
	FL Fuel System
	EX Exhaust System
	STR Starting System
	ACC Accelerator Control System
	HBC Hybrid Control System
	HBB Hybrid Battery System
C HYBRID	CL Clutch
	TM Transaxle & Transmission
	DLN Driveline
	FAX Front Axle
	RAX Rear Axle
D TRANSMISSION & DRIVE-LINE	FSU Front Suspension
	RSU Rear Suspension
	SCS Suspension Control System
	WT Road Wheels & Tires
	BR Brake System
E SUSPENSION	PB Parking Brake System
	BRC Brake Control System
	ST Steering System
F BRAKES	STC Steering Control System
	SB Seat Belt
G STEERING	SBC Seat Belt Control System
	SR SRS Airbag
H RESTRAINTS	SRC SRS Airbag Control System
	VTL Ventilation System
	HA Heater & Air Conditioning System
I VENTILATION, HEATER & AIR CONDITIONER	HAC Heater & Air Conditioning Control System
	INT Interior
J BODY INTERIOR	IP Instrument Panel
	SE Seat
	DLK Door & Lock
K BODY EXTERIOR, DOORS, ROOF & VEHICLE SECURITY	SEC Security Control System
	GW Glass & Window System
	PWC Power Window Control System
	RF Roof
	EXT Exterior
	BRM Body Repair Manual
	MIR Mirrors
L DRIVER CONTROLS	EXL Exterior Lighting System
	INL Interior Lighting System
	WW Wiper & Washer
	DEF Defogger
	HRN Horn
	PWO Power Outlet
M ELECTRICAL & POWER CONTROL	BCS Body Control System
	LAN LAN System
	PCS Power Control System
	CHG Charging System
	PG Power Supply, Ground & Circuit Elements
	MWI Meter, Warning Lamp & Indicator
N DRIVER INFORMATION & MULTIMEDIA	WCS Warning Chime System
	SN Sonar System
	AV Audio, Visual & Navigation System
O CRUISE CONTROL	CCS Cruise Control System
P MAINTENANCE	MA Maintenance
Q INDEX	IDX Alphabetical Index

A

B

C

D

E

F

G

H

I

J

K

L

M

N

O

P

Q

CLICK HERE TO **DOWNLOAD** THE COMPLETE MANUAL

- Thank you very much for reading the preview of the manual.
- You can download the complete manual from: www.heydownloads.com by clicking the link below



- Please note: If there is no response to CLICKING the link, please download this PDF first and then click on it.

CLICK HERE TO **DOWNLOAD** THE COMPLETE MANUAL

BASE AUDIO SYSTEM

< WIRING DIAGRAM >

[BASE AUDIO (EXCEPT MEXICO)]

Connector No.	D101
Connector Name	WIRE TO WIRE
Connector Color	WHITE

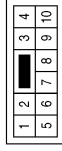

Terminal No.	Color of Wire	Signal Name
3	L/B	-
9	W/B	-

Connector No.	D12
Connector Name	FRONT DOOR SPEAKER LH
Connector Color	WHITE



Terminal No.	Color of Wire	Signal Name
1	L/W	-
2	L/R	-

Connector No.	D2
Connector Name	WIRE TO WIRE
Connector Color	BROWN

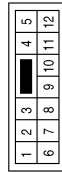

Terminal No.	Color of Wire	Signal Name
2	L/R	-
3	L/W	-

Connector No.	D153
Connector Name	WIRE TO WIRE
Connector Color	WHITE

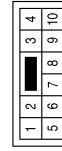

Terminal No.	Color of Wire	Signal Name
3	R	-
9	LG	-

Connector No.	D152
Connector Name	WIRE TO WIRE
Connector Color	WHITE



Terminal No.	Color of Wire	Signal Name
3	R	-
9	LG	-

Connector No.	D112
Connector Name	FRONT DOOR SPEAKER RH
Connector Color	WHITE



Terminal No.	Color of Wire	Signal Name
1	W/B	-
2	L/B	-

ABNIA6681GB

A
B
C
D
E
F
G
H
I
J
K
L
M
N
O
P

AV

DIAGNOSIS SYSTEM (AUDIO UNIT)

< SYSTEM DESCRIPTION >

[DISPLAY AUDIO SYSTEM]

DIAGNOSIS SYSTEM (AUDIO UNIT)

Description

INFOID:000000012563192

The audio unit on board diagnosis performs the functions listed in the table below:

Mode	Description	
Self Diagnosis	Audio unit diagnosis.	
Confirmation/ Adjustment	Display Diagnosis	The following check functions are available: color tone check by color spectrum bar display and gray scale check by gradation bar display.
	Vehicle Signals	Diagnosis of signals can be performed for vehicle speed, lights, reverse, EQ pin, ignition, destination and camera type.
	Speaker Test	The connection of a speaker can be confirmed by test tone.
	Error History	The system malfunction and the frequency when occurring in the past are displayed. When the malfunctioning item is selected, the time and place that the selected malfunction last occurred are displayed.
	Camera System	Displayed but not used.
	AV COMM Diagnosis	Displayed but not used.
	Delete Unit Connection Log	Erase the connection history of unit and error history.
	Version Information	Displays the audio system version information.
	Initialize Setting	Initializes the audio unit memory.

On Board Diagnosis Function

INFOID:000000012563193

METHOD OF STARTING

1. Turn the ignition ON.
2. Turn the audio unit OFF.
3. While pressing the preset 1 button, turn the volume control dial clockwise and counterclockwise quickly approximately 15 times or more. Shifting from current screen to previous screen is performed by pressing BACK button.

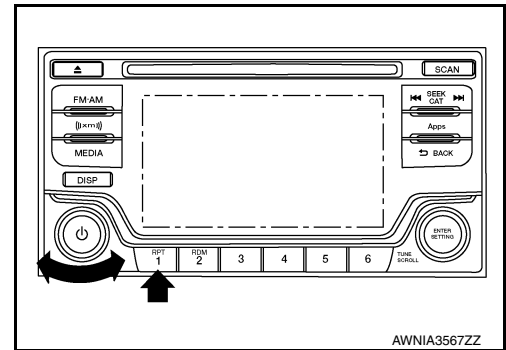

4. The trouble diagnosis initial screen is displayed, and Self Diagnosis or Confirmation/Adjustment can be selected.

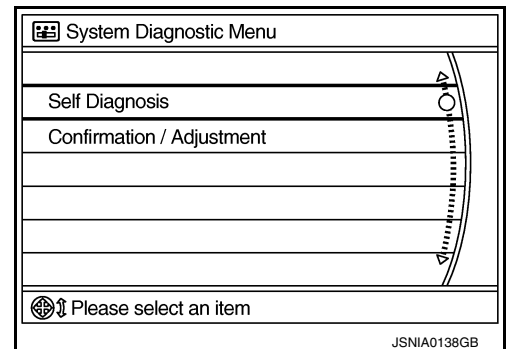

SELF DIAGNOSIS MODE

Audio Unit Self Diagnosis

1. Select Self Diagnosis.
2. Self diagnosis screen is displayed. The bar graph visible in center of screen indicates progress of self diagnosis.

AUDIO ANTENNA

< REMOVAL AND INSTALLATION >

[DISPLAY AUDIO SYSTEM]

AUDIO ANTENNA

Location of Antenna

INFOID:000000012563222

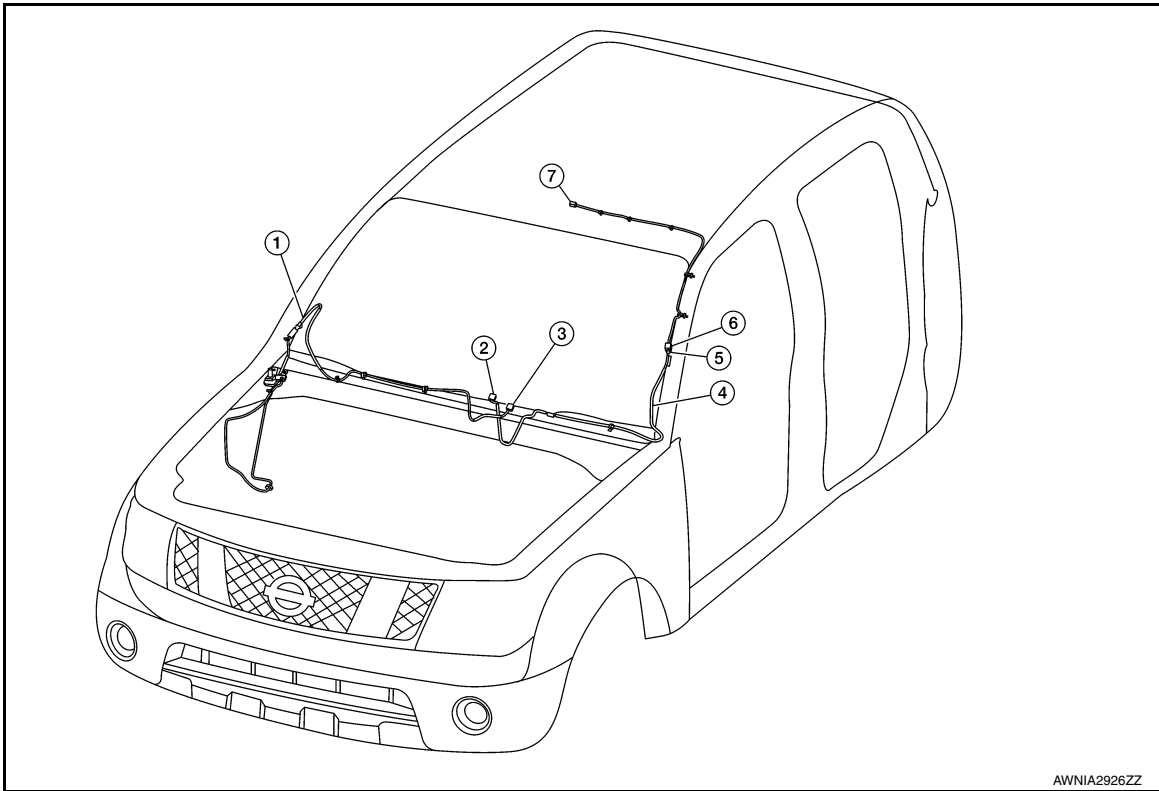

- | | | |
|-----------------------------|--------|---------|
| 1. Coaxial antenna feeder | 2. M41 | 3. M33 |
| 4. Satellite antenna feeder | 5. M67 | 6. M500 |
| 7. M501 | | |

Removal and Installation

INFOID:000000012563223

REMOVAL

1. Remove instrument lower panel RH and glove box. Refer to [IP-24, "Removal and Installation"](#).
2. Disconnect audio antenna cable from antenna feeder.

A
B
C
D
E
F
G
H
I
J
K
L
M
O
P

AV

U12AB ANTENNA

< DTC/CIRCUIT DIAGNOSIS >

[NAVIGATION WITH AMPLIFIER]

U12AB ANTENNA

DTC Logic

INFOID:0000000012563263

DTC DETECTION LOGIC

CONSULT Display	DTC Detection Condition	Possible Cause
FM Antenna error [U12AB]	Open or short to ground is detected in rod antenna connection.	<ul style="list-style-type: none">• Rod antenna disconnection.• Open or short to ground in antenna feeder.

Diagnosis Procedure

INFOID:0000000012563264

Regarding Wiring Diagram information, refer to [AV-173, "Wiring Diagram"](#).

1. ROD ANTENNA INSPECTION

Visually inspect the rod antenna and antenna feeder. Refer to [AV-266, "Location of Antenna"](#).

Is inspection result normal?

- YES >> Replace AV control unit. Refer to [AV-257, "Removal and Installation"](#).
- NO >> Repair or replace malfunctioning components.

REAR DOOR SPEAKER

< REMOVAL AND INSTALLATION >

[NAVIGATION WITH AMPLIFIER]

REAR DOOR SPEAKER

Removal and Installation

INFOID:000000012563300

REMOVAL

1. Remove the rear door finisher. Refer to [INT-15. "Removal and Installation"](#).
2. Remove the rear door speaker screws (A).
3. Disconnect the harness connector (B) from the rear door speaker (1) and remove.

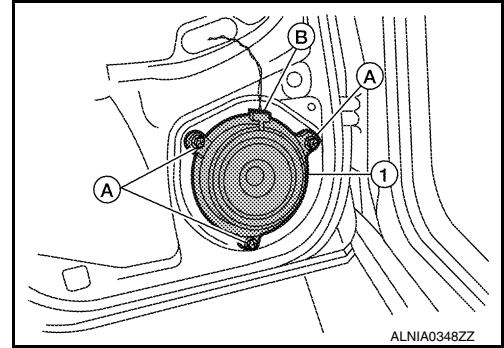

INSTALLATION

Installation is in the reverse order of removal.

A
B
C
D
E
F
G
H
I
J
K
L
M
AV
O
P

U12AD AV CONTROL UNIT

< DTC/CIRCUIT DIAGNOSIS >

[NAVIGATION WITHOUT AMPLIFIER]

U12AD AV CONTROL UNIT

DTC Logic

INFOID:000000012563347

DTC DETECTION LOGIC

CONSULT Display	DTC Detection Condition	Possible Cause
ECU Temperature too High [U12AD]	AV control unit temperature has exceeded maximum temperature.	Replace AV control unit if malfunction occurs constantly. Refer to AV-353, "Removal and Installation" .

SHIPPING MODE CANCEL OPERATION

< BASIC INSPECTION >

SHIPPING MODE CANCEL OPERATION

Work Procedure

INFOID:000000012563395

1. SHIPPING MODE CANCEL OPERATION

1. Turn ignition switch OFF.
2. Press in (turn on) the extended storage switch. Refer to [PG-84. "How To Check"](#).
3. Turn ignition switch ON.
4. Turn ignition switch OFF and wait at least 2 seconds.

>> GO TO 2.

2. SHIPPING MODE CANCEL CHECK

1. Turn ignition switch ON.
2. Check that extended storage warning message is not displayed in combination meter or display.

>> WORK END

PREPARATION

< PREPARATION >

PREPARATION

PREPARATION

Special Service Tool

INFOID:0000000012565304

The actual shape of the tools may differ from those illustrated here.

Tool number (TechMate No.) Tool name	Description
— (J-46532) Brake height tool	Measuring brake pedal height
38-PFM92 (—) ProCut™ PFM Series Lathe	Refinishing rotors

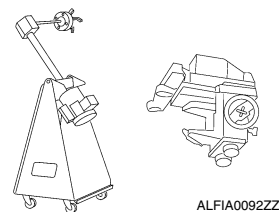
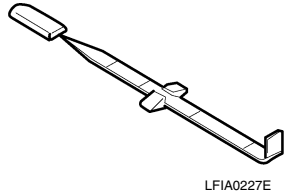

Commercial Service Tool

INFOID:0000000012565305

Tool name	Description
1. Flare nut crowfoot 2. Torque wrench	Tightening brake tube flare nuts a: 10 mm (0.39 in) / 12 mm (0.47 in)
Power tool	Loosening nuts, screws and bolts

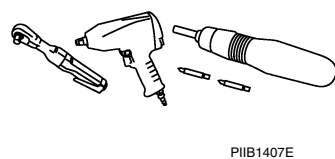
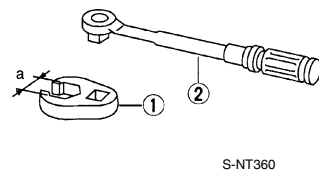

A
B
C
D
E
BR
G
H
I
J
K
L
M
N
O
P

ADJUSTMENT OF STEERING ANGLE SENSOR NEUTRAL POSITION : Description	153	C1101, C1102, C1103, C1104 WHEEL SENSOR	182
ADJUSTMENT OF STEERING ANGLE SENSOR NEUTRAL POSITION : Special Repair Requirement	153	DTC Description	182
CALIBRATION OF DECEL G SENSOR	154	Diagnosis Procedure	183
CALIBRATION OF DECEL G SENSOR : Description	154	C1105, C1106, C1107, C1108 WHEEL SENSOR	187
CALIBRATION OF DECEL G SENSOR : Special Repair Requirement	154	DTC Description	187
SYSTEM DESCRIPTION	156	Diagnosis Procedure	188
APPLICATION NOTICE	156	C1109 POWER AND GROUND SYSTEM	194
Application Notice	156	DTC Description	194
Hill descent control	157	Diagnosis Procedure	194
System Diagram	157	C1110 CONTROL FAILURE	196
Hydraulic Circuit Diagram	157	DTC Description	196
System Description	158	Diagnosis Procedure	196
Component Parts Location	159	C1111 ABS MOTOR, MOTOR RELAY SYSTEM	198
Component Description	160	Description	198
Hill start assist	161	DTC Description	198
System Diagram	161	Diagnosis Procedure	199
System Description	161	C1113, C1145, C1146 YAW RATE/SIDE/DECEL G SENSOR	201
Component Parts Location	162	Description	201
Component Description	163	DTC Description	201
VDC	164	Diagnosis Procedure	202
System Diagram	164	C1115 WHEEL SENSOR	205
System Description	164	Description	205
Component Parts Location	165	DTC Description	205
Component Description	166	Diagnosis Procedure	206
TCS	167	C1116 STOP LAMP SWITCH	212
System Diagram	167	Description	212
System Description	167	DTC Description	212
Component Parts Location	168	Diagnosis Procedure	213
Component Description	169	Component Inspection	215
ABS	170	C1120, C1122, C1124, C1126 ABS IN VALVE SYSTEM	217
System Diagram	170	Description	217
System Description	170	DTC Description	217
Component Parts Location	171	Diagnosis Procedure	218
Component Description	172	C1121, C1123, C1125, C1127 ABS OUT VALVE SYSTEM	219
EBD	173	DTC Description	219
System Diagram	173	Diagnosis Procedure	219
System Description	173	C1130, C1131, C1132, C1133, C1136 ENGINE SIGNAL	221
Component Parts Location	174	DTC Description	221
Component Description	175	Diagnosis Procedure	222
DIAGNOSIS SYSTEM [ABS ACTUATOR AND ELECTRIC UNIT (CONTROL UNIT)]	176	C1140 ACTUATOR RELAY SYSTEM	223
CONSULT Function (ABS)	176	Description	223
DTC/CIRCUIT DIAGNOSIS	181	DTC Description	223
APPLICATION NOTICE	181	Diagnosis Procedure	223
Application Notice	181		

C1115 WHEEL SENSOR

< DTC/CIRCUIT DIAGNOSIS >

[TYPE 1]

Install wheel sensor with no backlash and float, and tighten the mounting bolt to the specified torque.

- Front: Refer to [BRC-142, "Removal and Installation"](#).
- Rear: Refer to [BRC-142, "Removal and Installation"](#).

>> GO TO 6.

6. CHECK WHEEL SENSOR

Check the wheel sensor for damage.

Is the inspection result normal?

YES >> GO TO 7.

NO >> GO TO 8.

7. CHECK WHEEL SENSOR OUTPUT SIGNAL

1. Disconnect ABS actuator and electric unit (control unit) harness connector.
2. Connect ABS active wheel sensor tester (SST: J-45741-A) to wheel sensor using appropriate adapter.
3. Turn the ABS active wheel sensor tester power switch ON.

NOTE:

The green POWER indicator should illuminate. If the POWER indicator does not illuminate, replace the battery in the ABS active wheel sensor tester before proceeding.

4. Spin the wheel of the vehicle by hand and observe the red SENSOR indicator on the ABS active wheel sensor tester. The red SENSOR indicator should flash ON and OFF to indicate an output signal.

NOTE:

If the red SENSOR indicator illuminates but does not flash, reverse the polarity of the tester leads and retest.

Does the ABS active wheel sensor tester detect a signal?

YES >> GO TO 11.

NO >> GO TO 8.

8. REPLACE WHEEL SENSOR (1)

Ⓜ With CONSULT

1. Replace the wheel sensor.
 - Front: Refer to [BRC-142, "Removal and Installation"](#).
 - Rear: Refer to [BRC-142, "Removal and Installation"](#).
2. Connect ABS actuator and electric unit (control unit) harness connector.
3. Erase "Self Diagnostic Result" of "ABS"
4. Turn the ignition switch OFF → ON → OFF.

NOTE:

Wait at least 10 seconds after turning ignition switch OFF or ON.

5. Start the engine.
6. Select "DATA MONITOR" of "ABS", check "FR LH SENSOR", "FR RH SENSOR", "RR LH SENSOR" and "RR RH SENSOR".

NOTE:

Set the "DATA MONITOR" recording speed to "10 msec".

7. Read the values (wheel speed) of both the normal wheel sensors and malfunctioning wheel sensor.

NOTE:

Vehicle must be driven after repair or replacement to erase the previous DTCs.

Note the difference at 50 km/h (31 MPH) between the wheel speed detected by the malfunctioning wheel sensor and the maximum/minimum wheel speed detected by the normal wheel sensors. Is the difference within 5%, respectively?

YES >> GO TO 9.

NO >> GO TO 19.

9. PERFORM SELF-DIAGNOSIS (2)

Ⓜ With CONSULT

1. Stop the vehicle.
2. Turn the ignition switch OFF.

NOTE:

Wait at least 10 seconds after turning ignition switch OFF.

ABS ACTUATOR AND ELECTRIC UNIT (CONTROL UNIT)

< ECU DIAGNOSIS INFORMATION >

[TYPE 1]

ABS ACTUATOR AND ELECTRIC UNIT (CONTROL UNIT)

Reference Value

INFOID:000000012565472

VALUES ON THE DIAGNOSIS TOOL

CAUTION:

The display shows the control unit calculation data, so a normal value might be displayed even in the event the output circuit (harness) is open or short-circuited.

CONSULT MONITOR ITEM

Monitor item	Display content	Data monitor	
		Condition	Reference value in normal operation
FR LH SENSOR	Wheel speed	0 [km/h (MPH)]	Vehicle stopped
		Nearly matches the speed meter display (± 10% or less)	Vehicle running (Note 1)
FR RH SENSOR	Wheel speed	0 [km/h (MPH)]	Vehicle stopped
		Nearly matches the speed meter display (± 10% or less)	Vehicle running (Note 1)
RR LH SENSOR	Wheel speed	0 [km/h (MPH)]	Vehicle stopped
		Nearly matches the speed meter display (± 10% or less)	Vehicle running (Note 1)
RR RH SENSOR	Wheel speed	0 [km/h (MPH)]	Vehicle stopped
		Nearly matches the speed meter display (± 10% or less)	Vehicle running (Note 1)
DECEL G-SEN	Longitudinal acceleration detected by Decel G-Sensor	Vehicle stopped	Approx. 0 G
		Vehicle running	-1.7 to 1.7 G
FR RH IN SOL	Operation status of each solenoid valve	Actuator (solenoid valve) is active ("ACTIVE TEST" with CONSULT) or actuator relay is inactive (in fail-safe mode)	On
		When the actuator (solenoid valve) is not active and actuator relay is active (ignition switch ON)	Off
FR RH OUT SOL	Operation status of each solenoid valve	Actuator (solenoid valve) is active ("ACTIVE TEST" with CONSULT) or actuator relay is inactive (in fail-safe mode)	On
		When the actuator (solenoid valve) is not active and actuator relay is active (ignition switch ON)	Off
FR LH IN SOL	Operation status of each solenoid valve	Actuator (solenoid valve) is active ("ACTIVE TEST" with CONSULT) or actuator relay is inactive (in fail-safe mode)	On
		When the actuator (solenoid valve) is not active and actuator relay is active (ignition switch ON)	Off
FR LH OUT SOL	Operation status of each solenoid valve	Actuator (solenoid valve) is active ("ACTIVE TEST" with CONSULT) or actuator relay is inactive (in fail-safe mode)	On
		When the actuator (solenoid valve) is not active and actuator relay is active (ignition switch ON)	Off

TCS

< SYSTEM DESCRIPTION >

[TYPE 2]

- | | | |
|--|---|-------------------------|
| 10. Rear wheel sensor LH C11
Rear wheel sensor RH C10 | 11. Steering angle sensor (behind spiral cable) M47
(Steering wheel removed for clarity) | 12. VDC OFF switch M154 |
| 13. Stop lamp switch E39 | 14. Stop lamp relay E12 | |

A
B
C
D
E
BRC
G
H
I
J
K
L
M
N
O
P

INFOID:000000012565522

Component Description

Component parts		Reference
ABS actuator and electric unit (control unit)	Pump	BRC-198, "Description"
	Motor	
	Actuator relay	BRC-223, "Description"
	Solenoid valve	BRC-217, "Description"
	VDC switch-over valve	(Cut valve CV1, CV2)
(Suction valve SV1, SV2)		BRC-245, "Description"
Wheel sensor		BRC-205, "Description"
Yaw rate/side/decel G sensor		BRC-201, "Description"
Stop lamp switch		BRC-212, "Description"
Steering angle sensor		BRC-228, "Description"
Brake fluid level switch		BRC-234, "Description"
Hill descent control switch		BRC-254, "Description"
VDC OFF switch		BRC-256, "Description"
ABS warning lamp		BRC-258, "Description"
Brake warning lamp		BRC-259, "Description"
Hill descent control indicator lamp		BRC-260, "Description"
VDC OFF indicator lamp		BRC-261, "Description"
SLIP indicator lamp		BRC-263, "Description"

C1140 ACTUATOR RELAY SYSTEM

[TYPE 2]

< DTC/CIRCUIT DIAGNOSIS >

YES >> GO TO 3.

NO >> Repair / replace harness or connector, securely lock the connector, and GO TO 2.

2.PERFORM SELF-DIAGNOSIS

 With CONSULT

1. Turn the ignition switch OFF.

NOTE:

Wait at least 10 seconds after turning ignition switch OFF.

2. Start the engine.

NOTE:

Wait at least 10 seconds after starting the engine.

3. Perform "Self Diagnostic Result" of "ABS".

Is DTC "C1140" detected?

YES >> GO TO 3.

NO >> Inspection Ed.

3.CHECK ABS ACTUATOR AND ELECTRIC UNIT (CONTROL UNIT) POWER SUPPLY AND GROUND CIRCUIT

Check the ABS actuator and electric unit (control unit) power supply and ground circuits. Refer to [BRC-251, "Diagnosis Procedure"](#).

Is the inspection result normal?

YES >> GO TO 4.

NO >> Repair / replace harness, connector, fuse, or fusible link.

4.CHECK TERMINAL

Check the ABS actuator and electric unit (control unit) pin terminals for damage or loose connection with harness connector.

Is the inspection result normal?

YES >> Replace the ABS actuator and electric unit (control unit). Refer to [BRC-294, "Removal and Installation"](#).

NO >> Repair / replace harness, connector, or terminal.

APPLICATION NOTICE

< SYMPTOM DIAGNOSIS >

[TYPE 2]

SYMPTOM DIAGNOSIS

APPLICATION NOTICE

Application Notice

INFOID:0000000012565629

Service information	Remarks
TYPE 1	VDC/TCS/ABS
TYPE 2	HILL DESCENT CONTROL/HILL START ASSIST/VDC/TCS/ABS

A
B
C
D
E
F
G
H
I
J
K
L
M
N
O
P

BRC

BODY ALIGNMENT

< REMOVAL AND INSTALLATION >

Measurement Points (Crew Cab Long Bed)

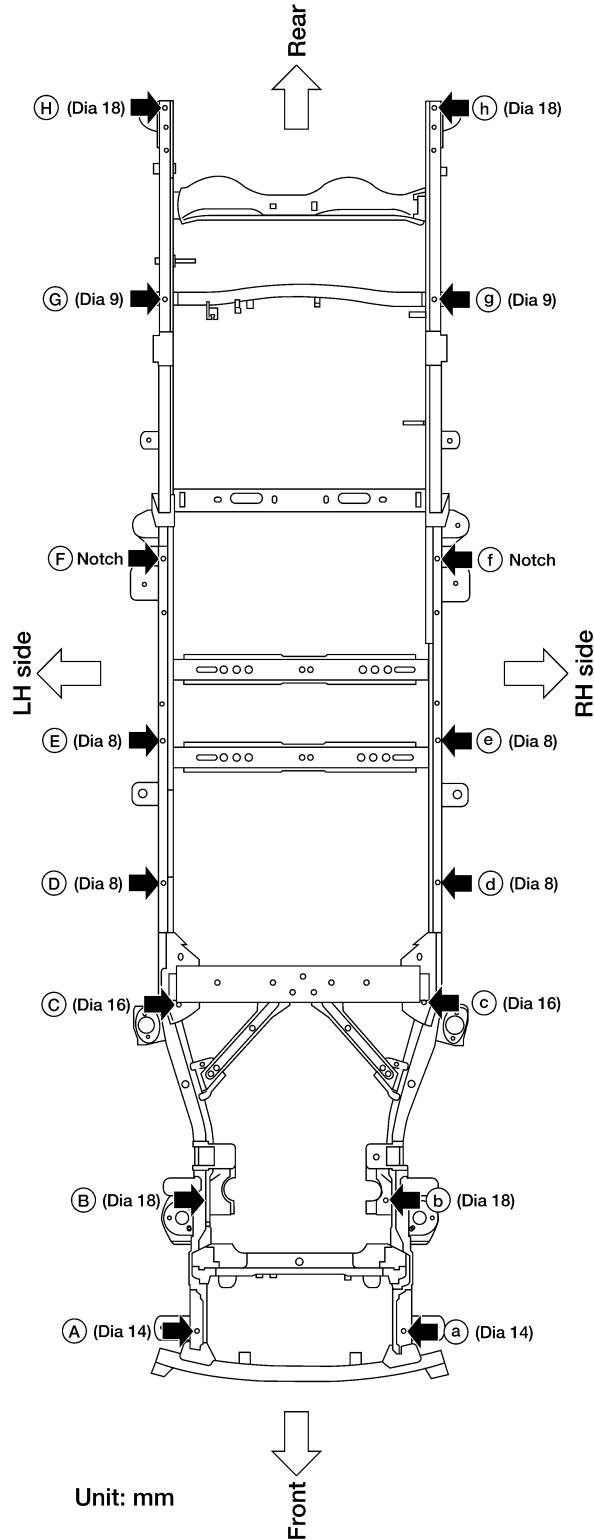

Coordinates:

- (A), (a)
X: ± 425.5
Y: -528
Z: 278
- (B), (b)
X: ± 354
Y: 34
Z: 307
- (C), (c)
X: ± 460
Y: 807
Z: 100
- (D), (d)
X: ± 574
Y: 1449
Z: 108
- (E), (e)
X: ± 570
Y: 2064
Z: 97
- (F), (f)
X: ± 551
Y: 2666
Z: 182
- (G), (g)
X: ± 562
Y: 3719
Z: 400
- (H), (h)
X: ± 553
Y: 4527
Z: 337

A
B
C
D
E
F
G
H
I
J
BRM
L
M
N
O
P

DIAGNOSIS AND REPAIR WORKFLOW

< BASIC INSPECTION >

- YES >> GO TO 10.
NO >> Repair as needed.

9.INSPECTION WITH CHARGE WARNING LAMP (ENGINE AT 3,000 RPM)

Increase and maintain the engine speed at 3,000 rpm.

Does the charge warning lamp remain off?

- YES >> GO TO 11.
NO >> GO TO 10.

10.INSPECTION OF GENERATOR PULLEY

Check generator pulley. Refer to [CHG-28, "Removal and Installation - QR25DE Models"](#) or [CHG-29, "Removal and Installation - VQ40DE Models"](#).

Is generator pulley normal?

- YES >> Replace generator. Refer to [CHG-28, "Removal and Installation - QR25DE Models"](#) or [CHG-29, "Removal and Installation - VQ40DE Models"](#).
NO >> Repair as needed.

11."B" TERMINAL CIRCUIT INSPECTION

Check "B" terminal circuit. Refer to [CHG-13, "Diagnosis Procedure"](#).

Is "B" terminal circuit normal?

- YES >> Replace generator. Refer to [CHG-28, "Removal and Installation - QR25DE Models"](#) or [CHG-29, "Removal and Installation - VQ40DE Models"](#).
NO >> Repair as needed.

12."B" TERMINAL CIRCUIT INSPECTION

Check "B" terminal circuit. Refer to [CHG-13, "Diagnosis Procedure"](#).

Is "B" terminal circuit normal?

- YES >> GO TO 13.
NO >> Repair as needed.

13.INSPECTION OF GENERATOR PULLEY

Check generator pulley. Refer to [CHG-28, "Removal and Installation - QR25DE Models"](#) or [CHG-29, "Removal and Installation - VQ40DE Models"](#).

Is generator pulley normal?

- YES >> Replace generator. Refer to [CHG-28, "Removal and Installation - QR25DE Models"](#) or [CHG-29, "Removal and Installation - VQ40DE Models"](#).
NO >> Repair as needed.

14."S" TERMINAL CIRCUIT INSPECTION

Check "S" terminal circuit. Refer to [CHG-17, "Diagnosis Procedure"](#).

Is the "S" terminal circuit normal?

- YES >> Replace generator. Refer to [CHG-28, "Removal and Installation - QR25DE Models"](#) or [CHG-29, "Removal and Installation - VQ40DE Models"](#).
NO >> Repair as needed.

Work Flow (Without EXP-800 NI or GR8-1200 NI)

INFOID:000000012563536

OVERALL SEQUENCE

Before performing a generator test, make sure that the battery is fully charged. A 30-volt voltmeter and suitable test probes are necessary for the test.

- Before starting, inspect the fusible link.

A
B
C
D
E
F
G
H
I
J
K
L
N
O
P

CHG

PRECAUTIONS

[QR25DE]

< PRECAUTION >

1. Remove the old liquid gasket adhering to the gasket application surface and the mating surface using suitable tool.
 - Remove the liquid gasket completely from the groove of the liquid gasket application surface, bolts, and bolt holes.
2. Thoroughly clean the mating surfaces and remove adhering moisture, grease and foreign material.

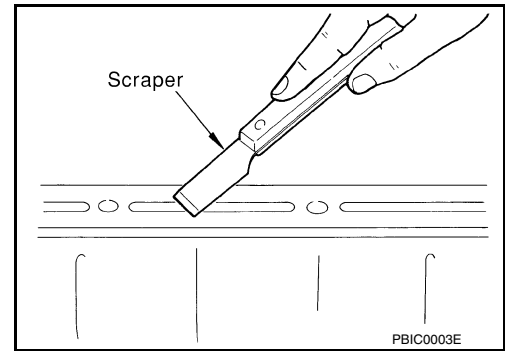

3. Attach the liquid gasket tube to the suitable tool.
Use Genuine RTV Silicone Sealant or equivalent. Refer to [GI-21, "Recommended Chemical Products and Sealants"](#).
4. Apply the liquid gasket without breaks to the specified location with the specified dimensions.

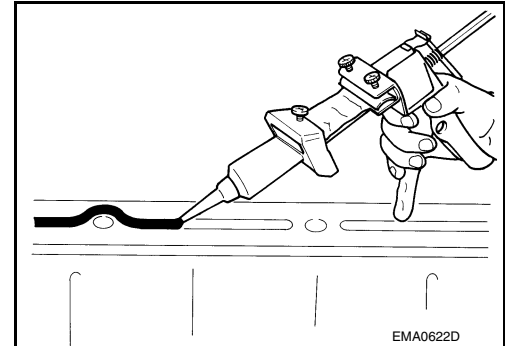

- If there is a groove for the liquid gasket application, apply the liquid gasket to the groove.
- Normally apply the liquid gasket on the inside edge of the bolt holes. Also apply to the outside edge of the bolt holes when specified in the procedure.
- Within five minutes of liquid gasket application, install the mating component.
- If the liquid gasket protrudes, wipe it off immediately.
- Do not retighten after the installation.
- Wait 30 minutes or more after installation before refilling the engine with oil or coolant.

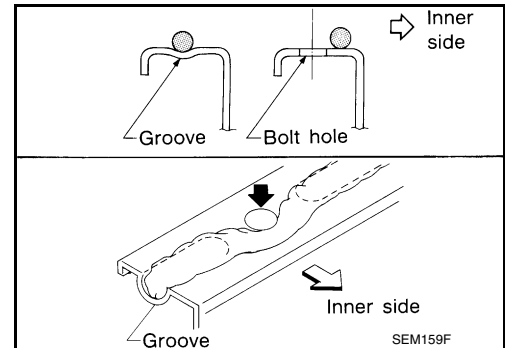

CAUTION:

If there are more specific instructions in the procedures contained in this manual concerning liquid gasket application, observe them.

WATER OUTLET AND WATER PIPING

< REMOVAL AND INSTALLATION >

[VQ40DE]

Installation is in the reverse order of removal.

CAUTION:

- Do not reuse O-ring.
- Do not reuse gasket.
- Securely insert each hose, and install clamp at a position where it does not interfere with the pipe bulge.
- Before inserting water pipe into water outlet, apply mild soap to O-ring.

INSPECTION AFTER INSTALLATION

- Check for engine coolant leaks. Refer to [CO-39. "System Inspection"](#).
- Start and warm up engine. Visually check for engine coolant leaks. Repair as necessary.

A

CO

C

D

E

F

G

H

I

J

K

L

M

N

O

P

DOOR LOCK FUNCTION

< SYSTEM DESCRIPTION >

DOOR LOCK FUNCTION DOOR LOCK AND UNLOCK SWITCH

DOOR LOCK AND UNLOCK SWITCH : System Diagram

INFOID:000000012563890

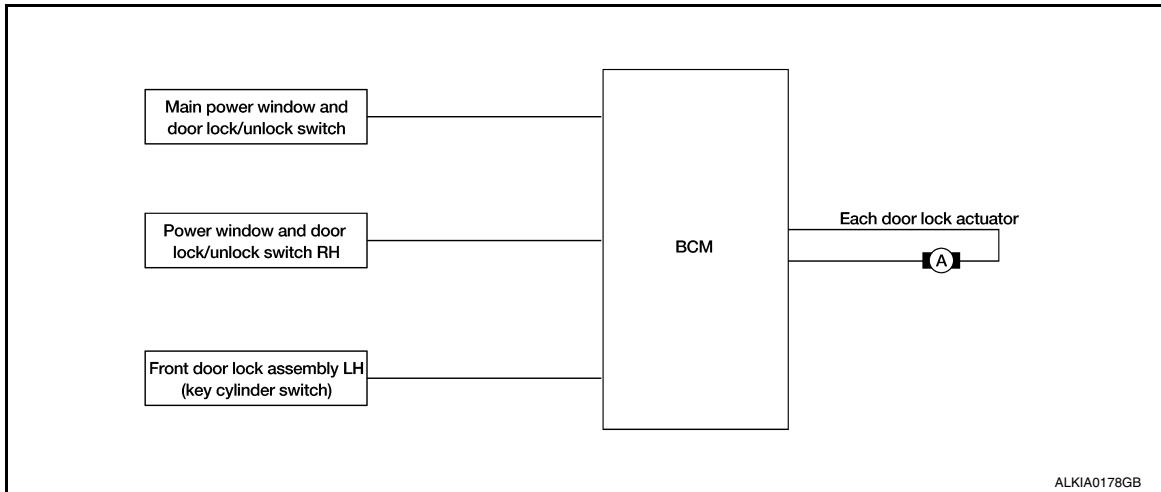

ALKIA0178GB

DOOR LOCK AND UNLOCK SWITCH : System Description

INFOID:000000012563891

Switch	Input/output signal to BCM	BCM function	Actuator
Main power window and door lock/unlock switch	Door lock/unlock signal	Door lock/unlock control	Door lock actuator
Power window and door lock/unlock switch RH			
Front door key cylinder switch			

DOOR LOCK FUNCTION

Functions Available by Operating the Door Lock and Unlock Switches on Driver Door and Passenger Door

- Interlocked with the locking operation of door lock and unlock switch, door lock actuators of all door lock actuators are locked.
- Interlocked with the unlocking operation of door lock and unlock switch, door lock actuators of all door lock actuators are unlocked.

Functions Available by Operating the Key Cylinder Switch on Driver Door

- Interlocked with the locking operation of door key cylinder, door lock actuators of all door lock actuators are locked.

Selective Unlock Operation

- When driver door key cylinder is unlocked, door lock actuator driver side is unlocked.
- When driver door key cylinder is unlocked for the second time within 5 seconds after the first operation, door lock actuators on all doors are unlocked.

Select unlock operation mode can be changed using AUTOMATIC DOOR UNLOCK SELECT mode in "WORK SUPPORT". Refer to [BCS-20, "DOOR LOCK : CONSULT Function \(BCM - DOOR LOCK\)"](#).

Key Reminder System

Refer to [DLK-42, "Diagnosis Procedure"](#).

SQUEAK AND RATTLE TROUBLE DIAGNOSES

< SYMPTOM DIAGNOSIS >

3. Loose screws at console attachment points.

SEATS

When isolating seat noise it's important to note the position the seat is in and the load placed on the seat when the noise is present. These conditions should be duplicated when verifying and isolating the cause of the noise.

Cause of seat noise include:

1. Headrest rods and holder
2. A squeak between the seat pad cushion and frame
3. The rear seatback lock and bracket

These noises can be isolated by moving or pressing on the suspected components while duplicating the conditions under which the noise occurs. Most of these incidents can be repaired by repositioning the component or applying urethane tape to the contact area.

UNDERHOOD

Some interior noise may be caused by components under the hood or on the engine wall. The noise is then transmitted into the passenger compartment.

Causes of transmitted underhood noise include:

1. Any component installed to the engine wall
2. Components that pass through the engine wall
3. Engine wall mounts and connectors
4. Loose radiator installation pins
5. Hood bumpers out of adjustment
6. Hood striker out of adjustment

These noises can be difficult to isolate since they cannot be reached from the interior of the vehicle. The best method is to secure, move or insulate one component at a time and test drive the vehicle. Also, engine rpm or load can be changed to isolate the noise. Repairs can usually be made by moving, adjusting, securing, or insulating the component causing the noise.

P1813 4WD SHIFT SWITCH

< DTC/CIRCUIT DIAGNOSIS >

[TRANSFER: TX15B]

P1813 4WD SHIFT SWITCH

Description

INFOID:000000012566129

The 4WD shift switch allows the driver to select 2WD or 4WD and 4H or 4LO. DTC P1813 will set if more than two switch inputs are simultaneously detected by the transfer control unit due to a short circuit in the 4WD shift switch.

DTC Logic

INFOID:000000012566130

DTC DETECTION LOGIC

DTC	CONSULT	Diagnostic item is detected when...	Reference
[P1813]	4WD MODE SW	More than two switch inputs are simultaneously detected due to short circuit of 4WD shift switch.	DLN-31

DTC CONFIRMATION PROCEDURE

1. DTC CONFIRMATION PROCEDURE

1. Turn ignition switch ON.
2. Perform self-diagnosis.

Is DTC P1813 displayed?

- YES >> Perform diagnosis procedure. Refer to [DLN-31, "Diagnosis Procedure"](#).
 NO >> Inspection End.

Diagnosis Procedure

INFOID:000000012566131

Regarding Wiring Diagram information, refer to [DLN-63, "Wiring Diagram"](#).

1. CHECK 4WD SHIFT SWITCH SIGNAL

With CONSULT

1. Turn ignition switch "ON".
2. Select "DATA MONITOR" mode for "ALL MODE AWD/4WD" with CONSULT.
3. Read out ON/OFF switching action of the "2WD SWITCH", "4H SWITCH", "4L SWITCH" with operating 4WD shift switch.

Without CONSULT

1. Turn ignition switch "ON".
2. Check voltage between transfer control unit harness connector terminals and ground.

Connector	Terminal	Condition	Voltage (Approx.)
M152	14 - Ground	4WD shift switch: 2WD	Battery voltage
		4WD shift switch: 4H and 4LO	0V
	15 - Ground	4WD shift switch: 4H	Battery voltage
		4WD shift switch: 2WD and 4LO	0V
	16 - Ground	4WD shift switch: 4LO	Battery voltage
		4WD shift switch: 2WD and 4H	0V

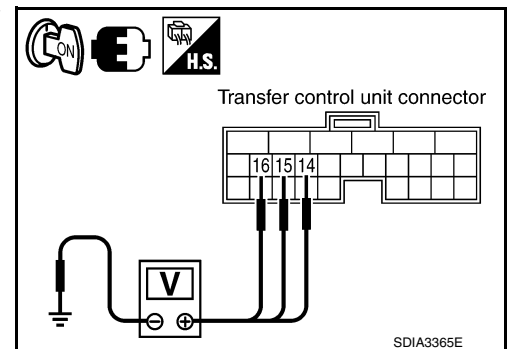

Are the inspection results normal?

- YES >> GO TO 5.

PRECAUTIONS

< PRECAUTION >

[TRANSFER: TX15B]

- When connecting or disconnecting pin connectors into or from transfer control unit, take care not to damage pin terminals (bend or break).
When connecting pin connectors make sure that there are not any bends or breaks on transfer control unit pin terminals.

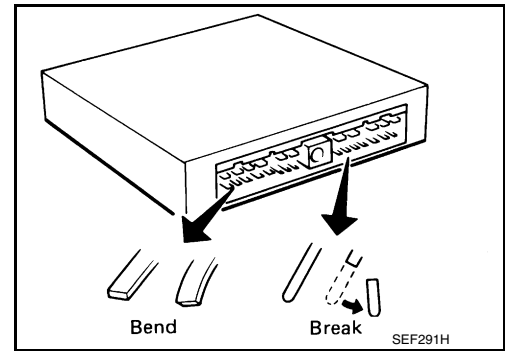

- Before replacing transfer control unit, perform transfer control unit input/output signal inspection and make sure transfer control unit functions properly. Refer to [DLN-56, "Reference Value"](#).

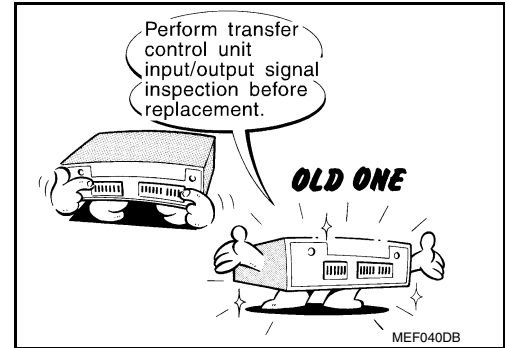

Service Notice

INFOID:000000012566185

- After overhaul refill the transfer with new transfer fluid.
- Check the fluid level or replace the fluid only with the vehicle parked on level ground.
- During removal or installation, keep inside of transfer clear of dust or dirt.
- Disassembly should be done in a clean work area.
- Before proceeding with disassembly, thoroughly clean the transfer. It is important to prevent the internal parts from becoming contaminated by dirt or other foreign matter.
- Check for the correct installation status prior to removal or disassembly. If matchmarks are required, be certain they do not interfere with the function of the parts when applied.
- All parts should be carefully cleaned with a general purpose, non-flammable solvent before inspection or reassembly.
- Check appearance of the disassembled parts for damage, deformation, and unusual wear. Replace them with a new ones if necessary.
- Gaskets, seals and O-rings should replaced any time the transfer is disassembled.
- In principle, tighten bolts or nuts gradually in several steps working diagonally from inside to outside. If tightening sequence is specified, use it.
- Observe the specified torque when assembling.
- Clean and flush the parts sufficiently and blow-dry them.
- Be careful not to damage sliding surfaces and mating surfaces.
- Use lint-free cloth or towels for wiping parts clean. Common shop rags can leave fibers that could interfere with the operation of the transfer.

NOISE, VIBRATION, AND HARSHNESS (NVH) TROUBLESHOOTING

< SYSTEM DESCRIPTION >

[PROPELLER SHAFT: 2S1330]

SYSTEM DESCRIPTION

NOISE, VIBRATION, AND HARSHNESS (NVH) TROUBLESHOOTING

NVH Troubleshooting Chart

INFOID:0000000012566213

Use the chart below to help you find the cause of the symptom. If necessary, repair or replace these parts.

Symptom	Possible cause and suspected parts											Reference page			
	Noise	Shake	Vibration	Uneven rotation torque	Rotation imbalance	Excessive run out	Differential	Axle	Suspension	Tires	Road wheel		Drive shaft	Brakes	Steering
	x		x	x	x	x	x	x	x	x	x	x	x	x	DLN-142 DLN-142 DLN-147 DLN-184, "NVH Troubleshooting Chart" DLN-218, "NVH Troubleshooting Chart" DLN-250, "NVH Troubleshooting Chart" DLN-274, "NVH Troubleshooting Chart" FAX-4, "NVH Troubleshooting Chart" RAX-5, "NVH Troubleshooting Chart" RAX-17, "NVH Troubleshooting Chart" FSU-5, "NVH Troubleshooting Chart" RSU-4, "NVH Troubleshooting Chart" WT-44, "NVH Troubleshooting Chart" WT-44, "NVH Troubleshooting Chart" DLN-132, "NVH Troubleshooting Chart" DLN-141, "NVH Troubleshooting Chart" DLN-141, "NVH Troubleshooting Chart" BR-6, "NVH Troubleshooting Chart" ST-5, "NVH Troubleshooting Chart"

x: Applicable

A
B
C
DLN
E
F
G
H
I
J
K
L
M
N
O
P

FRONT FINAL DRIVE

< UNIT DISASSEMBLY AND ASSEMBLY >

[FRONT FINAL DRIVE: R180A]

- If the tooth contact is near the flank (flank contact), or near the toe (toe contact), use a thinner drive pinion height adjusting washer to move the drive pinion farther from the drive gear. Refer to [DLN-212, "Inspection and Adjustment"](#).

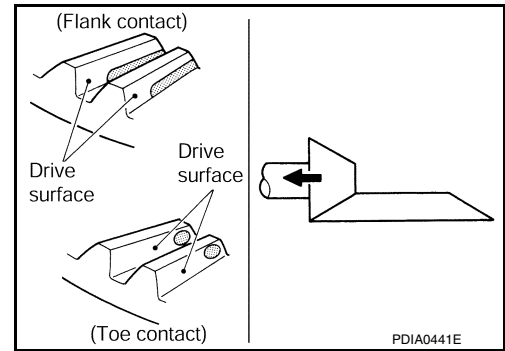

Backlash

1. Fit a dial indicator to the drive gear face to measure the backlash.

Backlash: Refer to [DLN-212, "Inspection and Adjustment"](#)

- If the backlash is outside of the specification, change the thickness of the side bearing adjusting washers.

If the backlash is greater than specification:

Make side bearing adjusting washer thicker on drive gear back side, and side bearing adjusting washer thinner on drive gear tooth side by the same amount. Refer to [DLN-212, "Inspection and Adjustment"](#).

If the backlash is less than specification:

Make side bearing adjusting washer thinner on drive gear back side, and side bearing adjusting washer thicker on drive gear tooth side by the same amount. Refer to [DLN-212, "Inspection and Adjustment"](#).

CAUTION:

Do not change the total thickness of side bearing adjusting washers as it will change the side bearing preload torque.

Companion Flange Runout

1. Rotate companion flange and check for runout on the companion flange face (inner side of the bolt holes) and companion flange inner side (socket diameter) using suitable tool.

Runout limit: Refer to [DLN-212, "Inspection and Adjustment"](#)

2. If the runout is outside the runout limit, follow the procedure below to adjust.
 - a. Rotate the companion flange on the drive pinion by 90°, 180° and 270° while checking for the position where the runout is minimum.
 - b. If the runout is still outside of the runout limit after the companion flange has been rotated on the drive pinion, possible cause could be an assembly malfunction of drive pinion and drive pinion bearing or a malfunctioning drive pinion bearing.
 - c. If the runout is still outside of the runout limit after repair of the assembly of drive pinion and drive pinion bearing or drive pinion bearing, replace the companion flange.

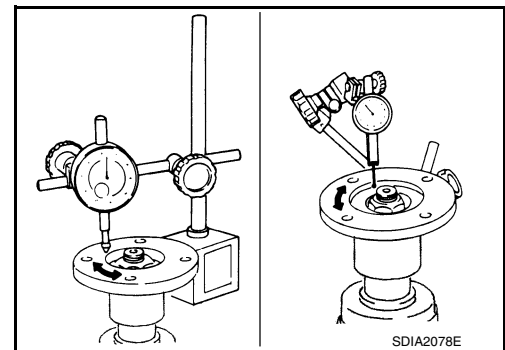

DISASSEMBLY

Differential side shaft

1. Drain the differential gear oil if necessary.

PERIODIC MAINTENANCE

DIFFERENTIAL GEAR OIL

Changing Differential Gear Oil

INFOID:000000012566281

DRAINING

1. Stop engine.
2. Remove the drain plug from the rear final drive assembly to drain the differential gear oil.
3. Install the drain plug with sealant applied on the threads to the rear final drive assembly. Tighten to the specified torque. Refer to [DLN-256, "Disassembly and Assembly"](#).
 - Use High Performance Thread Sealant or equivalent. Refer to [GI-21, "Recommended Chemical Products and Sealants"](#).

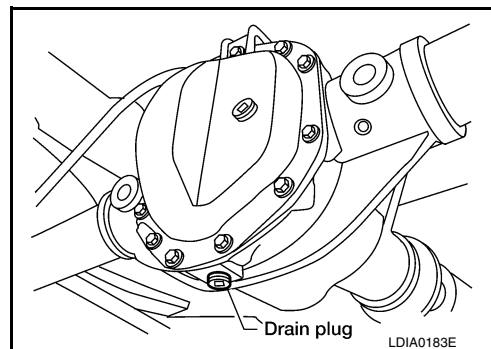

FILLING

1. Remove the filler plug from the rear final drive assembly.
2. Fill the rear final drive assembly with new differential gear oil until the level reaches the specified level near the filler plug hole.

Differential gear oil grade and capacity : Refer to [MA-18, "FOR USA AND CANADA : Fluids and Lubricants" \(United States and Canada\)](#) or [MA-21, "FOR MEXICO : Fluids and Lubricants" \(Mexico\)](#).

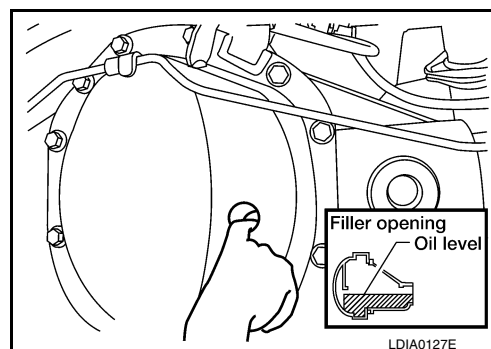

3. Install the filler plug with sealant applied on the threads to the rear final drive assembly. Tighten to the specified torque. Refer to [DLN-256, "Disassembly and Assembly"](#).
 - Use High Performance Thread Sealant or equivalent. Refer to [GI-21, "Recommended Chemical Products and Sealants"](#).

Checking Differential Gear Oil

INFOID:000000012566282

DIFFERENTIAL GEAR OIL LEAKAGE AND LEVEL

1. Make sure that differential gear oil is not leaking from the rear final drive assembly or around it.
2. Check the differential gear oil level from the filler plug hole as shown.

CAUTION:

Do not start engine while checking differential gear oil level.

3. Install the filler plug with sealant applied on the threads to the rear final drive assembly. Tighten to the specified torque. Refer to [DLN-256, "Disassembly and Assembly"](#).
 - Use High Performance Thread Sealant or equivalent. Refer to [GI-21, "Recommended Chemical Products and Sealants"](#).

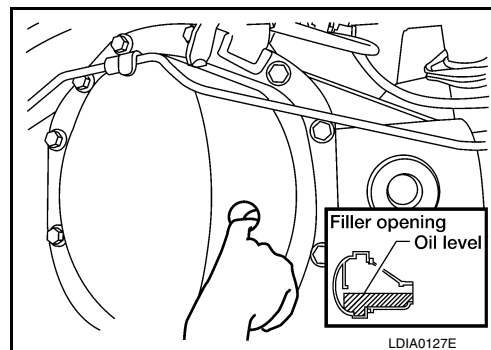

A
B
C
DLN
E
F
G
H
I
J
K
L
M
N
O
P

PRECAUTIONS

< PRECAUTION >

[REAR FINAL DRIVE: M226 (ELD)]

PRECAUTION

PRECAUTIONS

Precaution for Supplemental Restraint System (SRS) "AIR BAG" and "SEAT BELT PRE-TENSIONER"

INFOID:000000012566343

The Supplemental Restraint System such as "AIR BAG" and "SEAT BELT PRE-TENSIONER", used along with a front seat belt, helps to reduce the risk or severity of injury to the driver and front passenger for certain types of collision. This system includes seat belt switch inputs and dual stage front air bag modules. The SRS system uses the seat belt switches to determine the front air bag deployment, and may only deploy one front air bag, depending on the severity of a collision and whether the front occupants are belted or unbelted. Information necessary to service the system safely is included in the SR and SB section of this Service Manual.

WARNING:

- To avoid rendering the SRS inoperative, which could increase the risk of personal injury or death in the event of a collision which would result in air bag inflation, all maintenance must be performed by an authorized NISSAN/INFINITI dealer.
- Improper maintenance, including incorrect removal and installation of the SRS, can lead to personal injury caused by unintentional activation of the system. For removal of Spiral Cable and Air Bag Module, see the SR section.
- Do not use electrical test equipment on any circuit related to the SRS unless instructed to in this Service Manual. SRS wiring harnesses can be identified by yellow and/or orange harnesses or harness connectors.

PRECAUTIONS WHEN USING POWER TOOLS (AIR OR ELECTRIC) AND HAMMERS

WARNING:

- When working near the Airbag Diagnosis Sensor Unit or other Airbag System sensors with the Ignition ON or engine running, DO NOT use air or electric power tools or strike near the sensor(s) with a hammer. Heavy vibration could activate the sensor(s) and deploy the air bag(s), possibly causing serious injury.
- When using air or electric power tools or hammers, always switch the Ignition OFF, disconnect the battery and wait at least three minutes before performing any service.

Precaution

INFOID:000000012566344

- Before connecting or disconnecting differential lock control unit harness connector, turn ignition switch "OFF" and disconnect the battery cable from the negative terminal. Because battery voltage is applied to differential lock control unit even if ignition switch is turned "OFF".

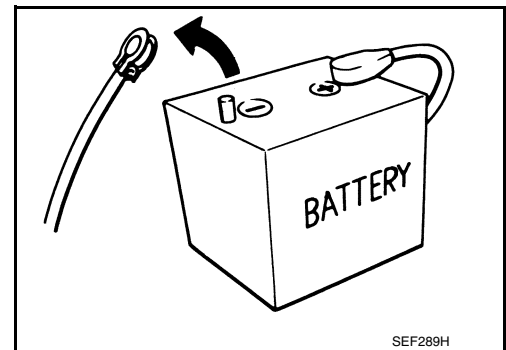

- When connecting or disconnecting pin connectors into or from differential lock control unit, take care not to damage pin terminals (bend or break). When connecting pin connectors make sure that there are not any bends or breaks on differential lock control unit pin terminal.

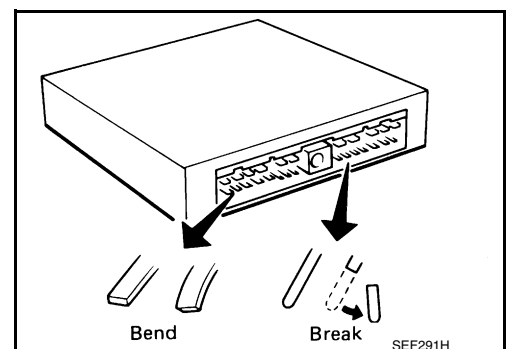

ENGINE CONTROL SYSTEM

< SYSTEM DESCRIPTION >

[QR25DE]

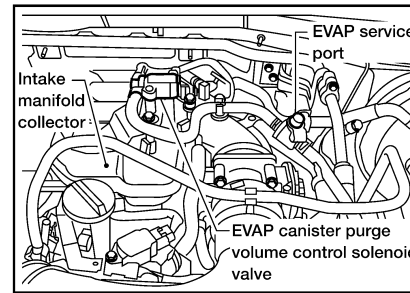
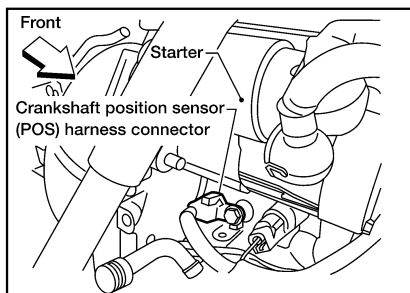
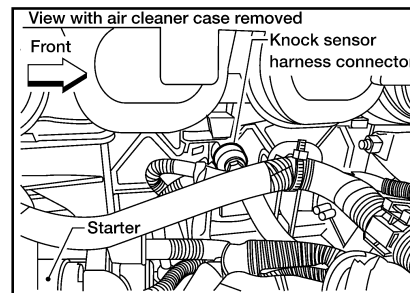
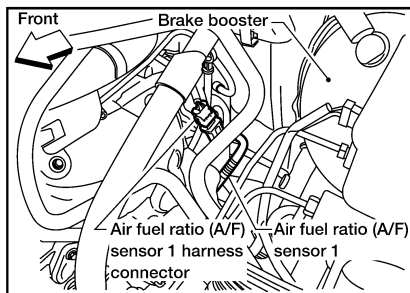
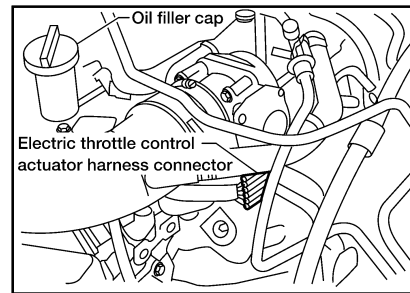
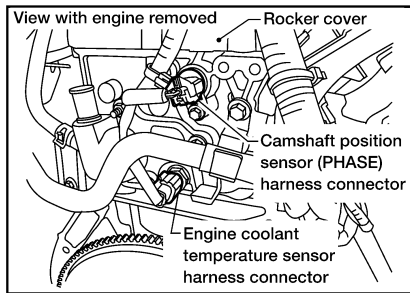
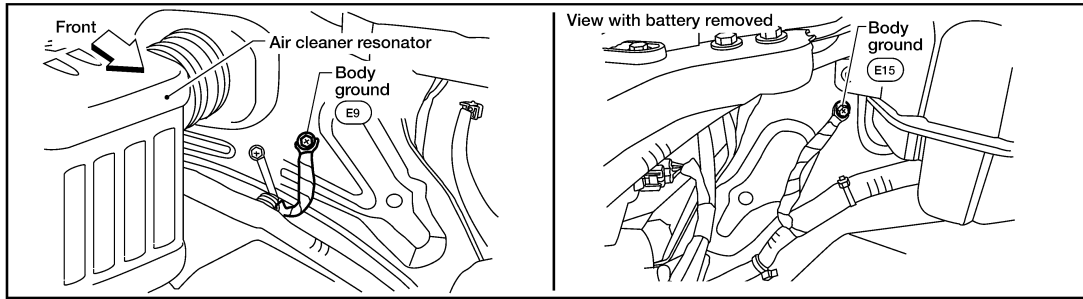

BBIA0611E

ECM

< ECU DIAGNOSIS INFORMATION >

[QR25DE]

DTC*1		Items (CONSULT screen terms)	SRT code	Trip	MIL	Permanent DTC group*4	Reference	
CONSULT GST*2	ECM*3							
P0183	0183	FTT SEN/CIRCUIT	—	2	×	B	EC-246	A
P0222	0222	TP SEN 1/CIRC	—	1	×	B	EC-249	EC
P0223	0223	TP SEN 1/CIRC	—	1	×	B	EC-249	
P0300	0300	MULTI CYL MISFIRE	—	1 or 2	×	B	EC-253	C
P0301	0301	CYL 1 MISFIRE	—	1 or 2	×	B	EC-253	
P0302	0302	CYL 2 MISFIRE	—	1 or 2	×	B	EC-253	D
P0303	0303	CYL 3 MISFIRE	—	1 or 2	×	B	EC-253	
P0304	0304	CYL 4 MISFIRE	—	1 or 2	×	B	EC-253	
P0327	0327	KNOCK SEN/CIRC-B1	—	2	—	—	EC-259	E
P0328	0328	KNOCK SEN/CIRC-B1	—	2	—	—	EC-259	
P0335	0335	CKP SEN/CIRCUIT	—	2	×	B	EC-262	F
P0340	0340	CMP SEN/CIRC-B1	—	2	×	B	EC-266	
P0420	0420	TW CATALYST SYS-B1	×	2	×	A	EC-270	G
P0441	0441	EVAP PURG FLOW/MON	×	2	×	A	EC-274	
P0442	0442	EVAP SMALL LEAK	×	2	×	A	EC-279	H
P0443	0443	PURG VOLUME CONT/V	—	2	×	A	EC-286	
P0444	0444	PURG VOLUME CONT/V	—	2	×	B	EC-291	I
P0445	0445	PURG VOLUME CONT/V	—	2	×	B	EC-291	
P0447	0447	VENT CONTROL VALVE	—	2	×	B	EC-294	J
P0448	0448	VENT CONTROL VALVE	—	2	×	B	EC-298	
P0451	0451	EVAP SYS PRES SEN	—	2	×	A	EC-302	K
P0452	0452	EVAP SYS PRES SEN	—	2	×	B	EC-306	
P0453	0453	EVAP SYS PRES SEN	—	2	×	B	EC-310	L
P0455	0455	EVAP GROSS LEAK	—	2	×	A	EC-315	
P0456	0456	EVAP VERY SML LEAK	×*7	2	×	A	EC-322	M
P0460	0460	FUEL LEV SEN SLOSH	—	2	×	A	EC-330	
P0461	0461	FUEL LEVEL SENSOR	—	2	×	B	EC-332	N
P0462	0462	FUEL LEVL SEN/CIRC	—	2	×	B	EC-334	
P0463	0463	FUEL LEVL SEN/CIRC	—	2	×	B	EC-334	O
P0500	0500	VEH SPEED SEN/CIRC*8	—	2	×	B	EC-337	
P0506	0506	ISC SYSTEM	—	2	×	B	EC-340	P
P0507	0507	ISC SYSTEM	—	2	×	B	EC-342	
P050A	050A	COLD START CONTROL	—	2	×	A	EC-344	
P050E	050E	COLD START CONTROL	—	2	×	A	EC-344	
P0550	0550	PW ST P SEN/CIRC	—	2	—	—	EC-346	
P0603	0603	ECM BACK UP/CIRCUIT	—	2	×	B	EC-349	
P0605	0605	ECM	—	1 or 2	× or —	B	EC-351	
P0607	0607	ECM	—	1 (A/T) 2 (M/T)	× (A/T) — (M/T)	B (A/T) — (M/T)	EC-353	
P0643	0643	SENSOR POWER/CIRC	—	1	×	B	EC-354	
P0700	0700	TRANSMISSION CONT	—	1	×	B	TM-170	
P0705	0705	T/M RANGE SENSOR A	—	2	×	B	TM-171	

HOW TO ERASE PERMANENT DTC

[QR25DE]

< BASIC INSPECTION >

4. Turn ignition switch ON.
5. Select "PERMANENT DTC STATUS" mode with CONSULT.

Ⓢ With GST

1. Turn ignition switch OFF and wait at least 10 seconds.
2. Turn ignition switch ON.
3. Turn ignition switch OFF and wait at least 10 seconds.
4. Turn ignition switch ON.
5. Select Service \$0A with GST.

Is any permanent DTC detected?

- YES >> GO TO 1.
NO >> END

P0127 IAT SENSOR

< DTC/CIRCUIT DIAGNOSIS >

[QR25DE]

P0127 IAT SENSOR

Component Description

INFOID:000000012567688

The intake air temperature sensor is built into mass air flow sensor (1). The sensor detects intake air temperature and transmits a signal to the ECM.

The temperature sensing unit uses a thermistor which is sensitive to the change in temperature. Electrical resistance of the thermistor decreases in response to the temperature rise.

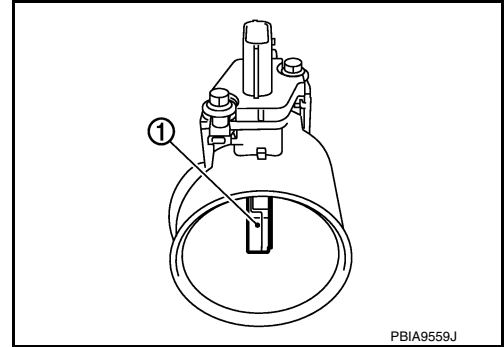

<Reference data>

Intake air temperature [°C (°F)]	Voltage* (V)	Resistance (kΩ)
25 (77)	3.3	1.800 - 2.200
80 (176)	1.2	0.283 - 0.359

*: This data is reference value and is measured between ECM terminal 50 (Intake air temperature sensor) and 56 (sensor ground).

CAUTION:

Never use ECM ground terminals when measuring input/output voltage. Doing so may result in damage to the ECM's transistor. Use a ground other than ECM terminals, such as the ground.

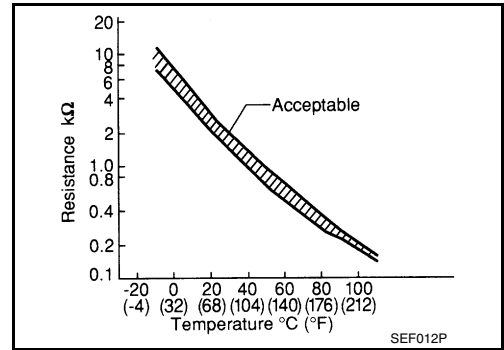

On Board Diagnosis Logic

INFOID:000000012567689

DTC No.	Trouble diagnosis name	DTC detecting condition	Possible cause
P0127 0127	Intake air temperature too high	Rationally incorrect voltage from the sensor is sent to ECM, compared with the voltage signal from engine coolant temperature sensor.	<ul style="list-style-type: none"> Harness or connectors (The sensor circuit is open or shorted) Intake air temperature sensor

DTC Confirmation Procedure

INFOID:000000012567690

CAUTION:

Always drive vehicle at a safe speed.

NOTE:

If DTC Confirmation Procedure has been previously conducted, always turn ignition switch OFF and wait at least 10 seconds before conducting the next test.

TESTING CONDITION:

This test may be conducted with the drive wheels lifted in the shop or by driving the vehicle. If a road test is expected to be easier, it is unnecessary to lift the vehicle.

Ⓟ WITH CONSULT

1. Wait until engine coolant temperature is less than 96°C (205°F)
 - a. Turn ignition switch ON.
 - b. Select "DATA MONITOR" mode with CONSULT.
 - c. Check the engine coolant temperature.
 - d. If the engine coolant temperature is not less than 96°C (205°F), turn ignition switch OFF and cool down engine.
 - Perform the following steps before engine coolant temperature is above 96°C (205°F).

P0222, P0223 TP SENSOR

[QR25DE]

< DTC/CIRCUIT DIAGNOSIS >

- Loosen and retighten two ground screws on the body. Refer to [EC-152. "Ground Inspection"](#).

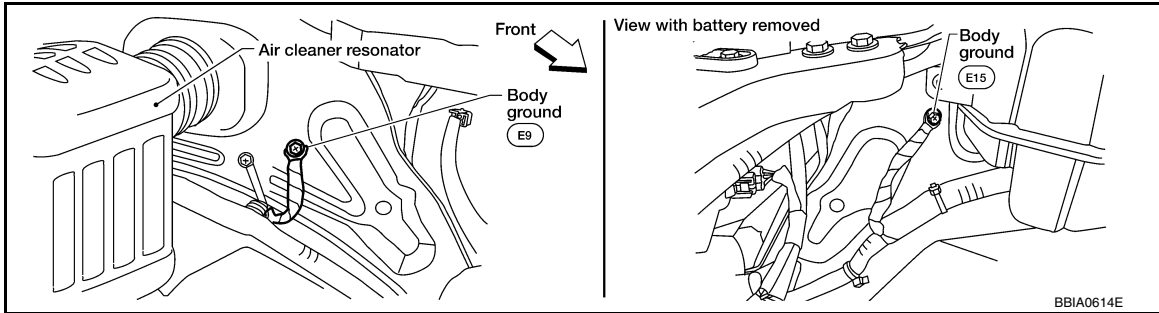

OK or NG

- OK >> GO TO 2.
 NG >> Repair or replace ground connections.

2. CHECK THROTTLE POSITION SENSOR 1 POWER SUPPLY CIRCUIT-I

- Disconnect electric throttle control actuator harness connector.
- Turn ignition switch ON.

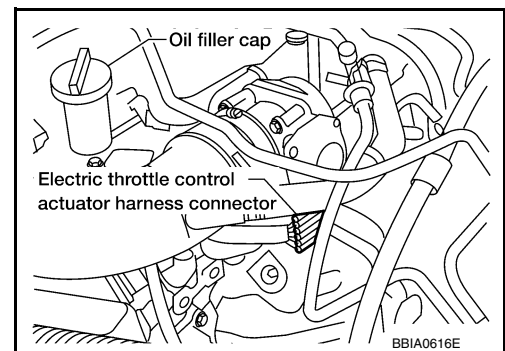

- Check voltage between electric throttle control actuator terminal 2 and ground with CONSULT or tester.

Voltage: Approximately 5V

OK or NG

- OK >> GO TO 7.
 NG >> GO TO 3.

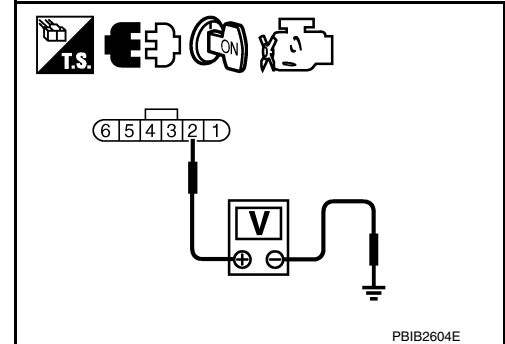

3. CHECK THROTTLE POSITION SENSOR 1 POWER SUPPLY CIRCUIT-II

- Turn ignition switch OFF.
- Disconnect ECM harness connector.
- Check harness continuity between electric throttle control actuator terminal 2 and ECM terminal 47. Refer to Wiring Diagram.

Continuity should exist.

OK or NG

- OK >> GO TO 4.
 NG >> Repair open circuit.

4. CHECK THROTTLE POSITION SENSOR 1 POWER SUPPLY CIRCUIT-III

Check harness for short to power and short to ground, between the following terminals.

ECM terminal	Sensor terminal
47	Electric throttle control actuator terminal 2
87	APP sensor terminal 1

P0451 EVAP CONTROL SYSTEM PRESSURE SENSOR

< DTC/CIRCUIT DIAGNOSIS >

[QR25DE]

4. If NG, replace EVAP control system pressure sensor.

A

EC

C

D

E

F

G

H

I

J

K

L

M

N

O

P

P0850 PNP SWITCH

[QR25DE]

< DTC/CIRCUIT DIAGNOSIS >

1. Disconnect ECM harness connector.
2. Check harness continuity between ECM terminal 101 and PNP switch terminal 1.
Refer to Wiring Diagram.

Continuity should exist.

3. Also check harness for short to ground and short to power.

OK or NG

- OK >> GO TO 5.
NG >> GO TO 4.

4. DETECT MALFUNCTIONING PART

Check the following.

- Harness connectors F14, E5
- Harness for open or short between PNP switch and ECM

>> Repair open circuit, short to ground or short to power in harness or connectors.

5. CHECK PNP SWITCH

Refer to [EC-96. "Wiring Diagram"](#).

OK or NG

- OK >> GO TO 6.
NG >> Replace PNP switch. Refer to [TM-83. "Disassembly"](#).

6. CHECK INTERMITTENT INCIDENT

Refer to [GI-43. "Intermittent Incident"](#).

>> **INSPECTION END**

P2119 ELECTRIC THROTTLE CONTROL ACTUATOR

< DTC/CIRCUIT DIAGNOSIS >

[QR25DE]

④ With CONSULT

1. Turn ignition switch ON and wait at least 1 second.
2. Set shift lever to D position (A/T) or 1st position (M/T) and wait at least 3 seconds.
3. Set shift lever to N, P position (A/T) or Neutral (M/T) position.
4. Start engine and let it idle for 3 seconds.
5. Check DTC.
6. If DTC is detected, go to [EC-415, "Diagnosis Procedure"](#).

④ With GST

Follow the procedure "With CONSULT" above.

Diagnosis Procedure

INFOID:000000012567964

1. CHECK ELECTRIC THROTTLE CONTROL ACTUATOR VISUALLY

1. Remove the intake air duct.
2. Check if a foreign matter is caught between the throttle valve and the housing.

OK or NG

- OK >> GO TO 2.
NG >> Remove the foreign matter and clean the electric throttle control actuator inside, and then perform throttle valve closed position learning. Refer to [EC-125, "Throttle Valve Closed Position Learning"](#).

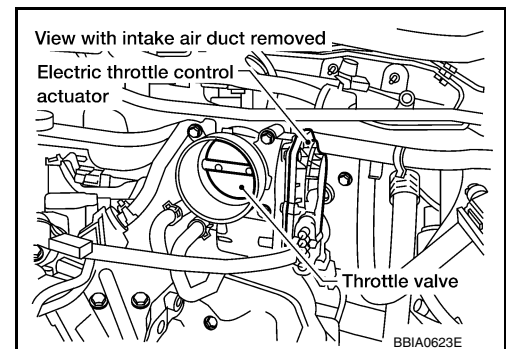

2. REPLACE ELECTRIC THROTTLE CONTROL ACTUATOR

1. Replace the electric throttle control actuator. Refer to [EM-27, "Exploded View"](#).
2. Perform [EC-125, "Throttle Valve Closed Position Learning"](#).
3. Perform [EC-126, "Idle Air Volume Learning"](#).

>> INSPECTION END

REFRIGERANT PRESSURE SENSOR

[QR25DE]

< DTC/CIRCUIT DIAGNOSIS >

OK >> GO TO 9.
NG >> GO TO 8.

8. DETECT MALFUNCTIONING PART

Check the following.

- Harness connectors E5, F14
- Harness for open or short between ECM and refrigerant pressure sensor

>> Repair open circuit, short to ground or short to power in harness or connectors.

9. CHECK INTERMITTENT INCIDENT

Refer to [GI-43, "Intermittent Incident"](#).

OK or NG

OK >> Replace refrigerant pressure sensor. Refer to [HA-36, "Removal and Installation"](#).
NG >> Repair or replace.

DIAGNOSIS SYSTEM (ECM)

[VQ40DE FOR USA AND CANADA]

< SYSTEM DESCRIPTION >

PERMANENT DTC SET TIMING

The setting timing of permanent DTC is stored in ECM with the lighting of MIL when a DTC is confirmed.

DIAGNOSIS DESCRIPTION : Malfunction Indicator Lamp (MIL)

INFOID:000000012568058

When emission-related ECU detects a malfunction in the emission control systems components and/or the powertrain control components (which affect vehicle emissions), it turns on/blinks MIL to inform the driver that a malfunction has been detected.

1. The MIL illuminates when ignition switch is turned ON (engine is not running).

NOTE:

Check the MIL circuit if MIL does not illuminate. Refer to [GI-39, "Work Flow"](#).

2. When the engine is started, the MIL should go off.

NOTE:

If MIL continues to illuminate/blink, perform self-diagnoses and inspect/repair accordingly because an emission-related ECU has detected a malfunction in the emission control systems components and/or the powertrain control components (which affect vehicle emissions).

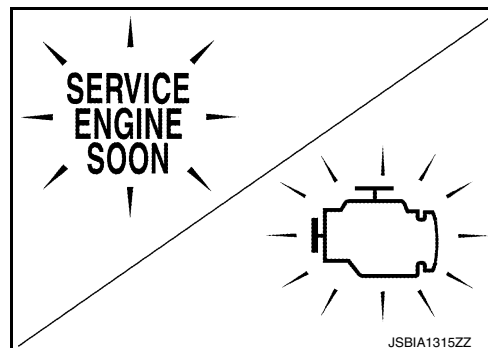

On Board Diagnosis Function

INFOID:000000012568059

ON BOARD DIAGNOSIS ITEM

The on board diagnostic system has the following functions.

Diagnostic test mode	Function
Bulb check	MIL can be checked.
SRT status	ECM can read if SRT codes are set.
Malfunction warning	If ECM detects a malfunction, it illuminates or blinks MIL to inform the driver that a malfunction has been detected.
Self-diagnostic results	DTCs or 1st trip DTCs stored in ECM can be read.
Accelerator pedal released position learning	ECM can learn the accelerator pedal released position. Refer to EC-603, "Accelerator Pedal Released Position Learning" .
Throttle valve closed position learning	ECM can learn the throttle valve closed position. Refer to EC-604, "Throttle Valve Closed Position Learning" .
Idle air volume learning	ECM can learn the idle air volume. Refer to EC-604, "Idle Air Volume Learning" .

BULB CHECK MODE

Description

This function allows damage inspection in the MIL bulb (blown, open circuit, etc.).

Operation Procedure

1. Turn ignition switch ON.
2. The MIL on the instrument panel should stay ON.
If it remains OFF, check MIL circuit. Refer to [GI-39, "Work Flow"](#).

SRT STATUS MODE

Description

This function allows to read if ECM has completed the self-diagnoses of major emission control systems and components. For SRT, refer to [EC-523, "DIAGNOSIS DESCRIPTION : System Readiness Test \(SRT\) Code"](#).

Operation Procedure

1. Turn ignition switch ON and wait 20 seconds.
2. SRT status is indicated as shown blow.
 - ECM continues to illuminate MIL if all SRT codes are set.

ENGINE CONTROL SYSTEM

[VQ40DE FOR USA AND CANADA]

< WIRING DIAGRAM >

Connector No.	E160
Connector Name	FUSE BLOCK (J/B)
Connector Color	WHITE

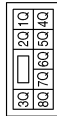

Terminal No.	Color of Wire	Signal Name
1Q	W/G	-
8Q	R/B	-

Connector No.	E161
Connector Name	BATTERY CURRENT SENSOR
Connector Color	BLACK



Terminal No.	Color of Wire	Signal Name
1	P	-
2	B	-(WITH VQ40DE)
3	R	-(WITH VQ40DE EXCEPT FOR MEXICO)

Connector No.	E201
Connector Name	WIRE TO WIRE
Connector Color	GRAY

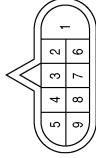

Terminal No.	Color of Wire	Signal Name
3	BR	-
9	V	-

Connector No.	E212
Connector Name	ENGINE OIL TEMPERATURE SENSOR
Connector Color	GRAY



Terminal No.	Color of Wire	Signal Name
1	V	-
2	BR	-

Connector No.	F2
Connector Name	AIR FUEL RATIO (A/F) SENSOR 1 (BANK 2) (WITH VQ40DE EXCEPT FOR MEXICO)
Connector Color	GRAY



Terminal No.	Color of Wire	Signal Name
1	BR	-
2	B/R	-
3	G	-
4	W/R	-

Connector No.	F11
Connector Name	CRANKSHAFT POSITION SENSOR (POS)
Connector Color	BLACK



Terminal No.	Color of Wire	Signal Name
1	R	-
2	G	-
3	BR	-(WITH VQ40DE)

ABBIA2507GB

P0011, P0021 IVT CONTROL

< DTC/CIRCUIT DIAGNOSIS >

[VQ40DE FOR USA AND CANADA]

ENG SPEED	1,400 - 3,175 rpm (A constant rotation is maintained.)
COOLAN TEMP/S	More than 60°C (140°F)
Selector lever	1st or 2nd position
Driving location uphill	Driving vehicle uphill (Increased engine load will help maintain the driving conditions required for this test.)

8. Check 1st trip DTC.
9. If the 1st trip DTC is detected, go to [EC-635, "Diagnosis Procedure"](#).

Ⓢ WITH GST

Follow the procedure "WITH CONSULT" above.

Diagnosis Procedure

INFOID:000000012568101

1. CHECK OIL PRESSURE WARNING LAMP

1. Start engine.
2. Check oil pressure warning lamp and confirm it is not illuminated.

OK or NG

- OK >> GO TO 2.
- NG >> Go to [LU-23, "Changing Engine Oil"](#).

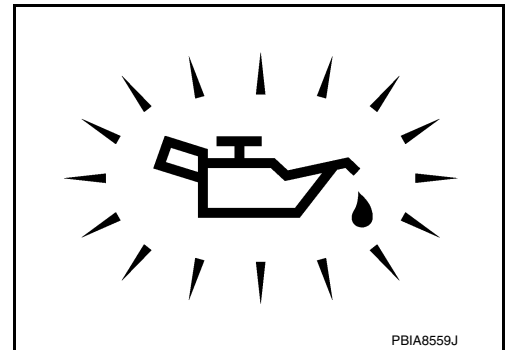

2. CHECK INTAKE VALVE TIMING CONTROL SOLENOID VALVE

Refer to [EC-636, "Component Inspection"](#).

OK or NG

- OK >> GO TO 3.
- NG >> Replace malfunctioning intake valve timing control solenoid valve. Refer to [EM-195, "Exploded View"](#).

3. CHECK CRANKSHAFT POSITION SENSOR (POS)

Refer to [EC-757, "Component Inspection"](#).

OK or NG

- OK >> GO TO 4.
- NG >> Replace crankshaft position sensor (POS). Refer to [TM-305, "Component"](#).

4. CHECK CAMSHAFT POSITION SENSOR (PHASE)

Refer to [EC-760, "Component Inspection"](#).

OK or NG

- OK >> GO TO 5.
- NG >> Replace malfunctioning camshaft position sensor (PHASE). Refer to [EM-195, "Exploded View"](#).

5. CHECK CAMSHAFT (INTAKE)

Check the following.

< DTC/CIRCUIT DIAGNOSIS >

7. Let engine idle for 1 minute.
8. Check that "COOLAN TEMP/S" indicates more than 70°C (158°F).
If not, warm up engine and go to next step when "COOLAN TEMP/S" indication reaches 70°C (158°F).
9. Open engine hood.
10. Select "HO2S2 (B1) P1147" (for DTC P0137) or "HO2S2 (B2) P1167" (for DTC P0157) of "HO2S2" in "DTC WORK SUPPORT" mode with CONSULT.
11. Follow the instruction of CONSULT.

NOTE:

It will take at most 10 minutes until "COMPLETED" is displayed.

12. Check that "OK" is displayed after touching "SELF-DIAG RESULTS".
If "NG" is displayed, refer to [EC-690, "Diagnosis Procedure"](#).
If "CAN NOT BE DIAGNOSED" is displayed, perform the following.
 - a. Turn ignition switch OFF and leave the vehicle in a cool place (soak the vehicle).
 - b. Return to step 1.

Overall Function Check

INFOID:000000012568185

Use this procedure to check the overall function of the heated oxygen sensor 2 circuit. During this check, a 1st trip DTC might not be confirmed.

 WITH GST

1. Start engine and warm it up to the normal operating temperature.
2. Turn ignition switch OFF and wait at least 10 seconds.
3. Turn ignition switch ON.
4. Turn ignition switch OFF and wait at least 10 seconds.
5. Start engine and keep the engine speed between 3,500 and 4,000 rpm for at least 1 minute under no load.
6. Let engine idle for 1 minute.
7. Set voltmeter probes between ECM terminal 57 [HO2S2 (B1) signal] or 58 [HO2S2 (B2) signal] and ground.
8. Check the voltage when revving up to 4,000 rpm under no load at least 10 times.
(Depress and release accelerator pedal as soon as possible.)
The voltage should be above 0.71V and below 0.18V at least once during this procedure.
If the voltage can be confirmed in step 6, step 7 is not necessary.
9. Keep vehicle at idling for 10 minutes, then check the voltage. Or check the voltage when coasting from 80 km/h (50 MPH) in D position with "OD" OFF (A/T), 5th gear position (M/T).
The voltage should be above 0.71V and below 0.18V at least once during this procedure.
10. If NG, go to [EC-690, "Diagnosis Procedure"](#).

Diagnosis Procedure

INFOID:000000012568186

1. CHECK GROUND CONNECTIONS

1. Turn ignition switch OFF.
2. Loosen and retighten three ground screws on the body. Refer to [EC-631, "Ground Inspection"](#).

OK or NG

- OK >> GO TO 2.
NG >> Repair or replace ground connections. Refer to [EX-5, "Exploded View"](#).

2. CLEAR THE SELF-LEARNING DATA

 With CONSULT

1. Start engine and warm it up to normal operating temperature.
2. Select "SELF-LEARNING CONT" in "WORK SUPPORT" mode with CONSULT.
3. Clear the self-learning control coefficient by touching "CLEAR".
4. Run engine for at least 10 minutes at idle speed.
Is the 1st trip DTC P0171 or P0174 detected?
Is it difficult to start engine?

P0300, P0301, P0302, P0303, P0304, P0305, P0306 MISFIRE

< DTC/CIRCUIT DIAGNOSIS >

[VQ40DE FOR USA AND CANADA]

3. Turn ignition switch OFF and wait at least 10 seconds.
4. Turn ignition switch ON.
5. Turn ignition switch OFF and wait at least 10 seconds.
6. Restart engine and let it idle for about 15 minutes.
7. Check 1st trip DTC.
8. If 1st trip DTC is detected, go to [EC-745, "Diagnosis Procedure"](#).

NOTE:

If 1st trip DTC is not detected during above procedure, performing the following procedure is advised.

- a. Turn ignition switch OFF and wait at least 10 seconds.
- b. Turn ignition switch ON.
- c. Turn ignition switch OFF and wait at least 10 seconds.
- d. Start engine and drive the vehicle under similar conditions to (1st trip) Freeze Frame Data for a certain time. Refer to the table below.

Hold the accelerator pedal as steady as possible.

Similar conditions to (1st trip) Freeze Frame Data mean that the following conditions should be satisfied at the same time.

Engine speed	Engine speed in the freeze frame data \pm 400 rpm
Basic fuel schedule	Basic fuel schedule in freeze frame data \times (1 \pm 0.1)
Engine coolant temperature (T) condition	When the freeze frame data shows lower than 70 °C (158 °F), T should be lower than 70 °C (158 °F).
	When the freeze frame data shows higher than or equal to 70 °C (158 °F), T should be higher than or equal to 70 °C (158 °F).

Driving time varies according to the engine speed in the freeze frame data.

Engine speed	Time
Around 1,000 rpm	Approximately 10 minutes
Around 2,000 rpm	Approximately 5 minutes
More than 3,000 rpm	Approximately 3.5 minutes

WITH GST

Follow the procedure "WITH CONSULT" above.

Diagnosis Procedure

INFOID:0000000012568233

1. CHECK GROUND CONNECTION

Check the following.

- Connection condition of the ground F10 and F16
- Connection condition of the ground harness between the engine assembly and vehicle body (if equipped)

Is the inspection result normal?

YES >> GO TO 2.

NO >> Repair or replace the error-detected parts.

2. CHECK FOR INTAKE AIR LEAK AND PCV HOSE

1. Start the engine and run it at idle speed.
2. Listen for the sound of the intake air leak.
3. Check PCV hose connection.

Is the inspection result normal?

YES >> GO TO 3.

NO >> Discover air leak location and repair.

3. CHECK FOR EXHAUST SYSTEM CLOGGING

P0452 EVAP CONTROL SYSTEM PRESSURE SENSOR

[VQ40DE FOR USA AND CANADA]

< DTC/CIRCUIT DIAGNOSIS >

9. If 1st trip DTC is detected, go to [EC-800, "Diagnosis Procedure"](#).

 WITH GST

1. Start engine and warm it up to normal operating temperature.
2. Check that voltage between ECM terminal 111 (Fuel tank temperature sensor signal) and ground is less than 4.2V.
3. Turn ignition switch OFF and wait at least 10 seconds.
4. Turn ignition switch ON.
5. Turn ignition switch OFF and wait at least 10 seconds.
6. Start engine and wait at least 20 seconds.
7. Select Service \$07 with GST.
If 1st trip DTC is detected, go to [EC-800, "Diagnosis Procedure"](#).

Diagnosis Procedure

INFOID:000000012568291

1. CHECK GROUND CONNECTIONS

1. Turn ignition switch OFF.
2. Loosen and retighten three ground screws on the body. Refer to [EC-631, "Ground Inspection"](#).

OK or NG

- OK >> GO TO 2.
NG >> Repair or replace ground connections.

2. CHECK CONNECTOR

1. Disconnect EVAP control system pressure sensor (2) harness connector.
 - EVAP canister vent control valve (1)
 - Drain filter (3)
 - EVAP canister (4)
 -  Vehicle front
2. Check sensor harness connector for water.

Water should not exist.

OK or NG

- OK >> GO TO 3.
NG >> Repair or replace harness connector.

3. CHECK EVAP CONTROL SYSTEM PRESSURE SENSOR POWER SUPPLY CIRCUIT

1. Turn ignition switch ON.
2. Check voltage between EVAP control system pressure sensor terminal 3 and ground with CONSULT or tester.

Voltage: Approximately 5V

OK or NG

- OK >> GO TO 5.
NG >> GO TO 4.

4. DETECT MALFUNCTIONING PART

Check the following.

- Harness connectors C1, E41
- Harness for open or short between EVAP control system pressure sensor and ECM

>> Repair open circuit or short to ground or short to power in harness or connectors.

5. CHECK EVAP CONTROL SYSTEM PRESSURE SENSOR GROUND CIRCUIT FOR OPEN AND SHORT

1. Turn ignition switch OFF.
2. Disconnect ECM harness connector.

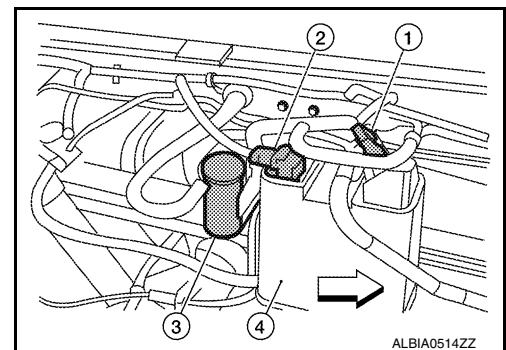

P1212 TCS COMMUNICATION LINE

< DTC/CIRCUIT DIAGNOSIS >

[VQ40DE FOR USA AND CANADA]

P1212 TCS COMMUNICATION LINE

Description

INFOID:000000012568364

NOTE:

- If DTC P1212 is displayed with DTC UXXXX, first perform the trouble diagnosis for DTC UXXXX.
- If DTC P1212 is displayed with DTC P0607, first perform the trouble diagnosis for DTC P0607. Refer to [EC-844, "DTC Logic"](#).

This CAN communication line is used to control the smooth engine operation during the TCS operation. Pulse signals are exchanged between ECM and "ABS actuator and electric unit (control unit)".

Be sure to erase the malfunction information such as DTC not only for "ABS actuator and electric unit (control unit)" but also for ECM after TCS related repair.

On Board Diagnosis Logic

INFOID:000000012568365

Freeze frame data is not stored in the ECM for this self-diagnosis. The MIL will not illuminate for this self-diagnosis.

DTC No.	Trouble diagnosis name	DTC detecting condition	Possible cause
P1212 1212	TCS communication line	ECM cannot receive the information from "ABS actuator and electric unit (control unit)".	<ul style="list-style-type: none">• Harness or connectors (The CAN communication line is open or shorted.)• ABS actuator and electric unit (control unit)• Dead (Weak) battery

DTC Confirmation Procedure

INFOID:000000012568366

TESTING CONDITION:

Before performing the following procedure, confirm that battery voltage is more than 10.5V at idle.

1. Start engine and let it idle for at least 10 seconds.
2. Check 1st trip DTC.
3. If 1st trip DTC is detected, go to [EC-855, "Diagnosis Procedure"](#).

Diagnosis Procedure

INFOID:000000012568367

Go to [BRC-8, "Work Flow"](#) (TYPE 1) or [BRC-150, "Work Flow"](#) (TYPE 2).

P2101 ELECTRIC THROTTLE CONTROL FUNCTION

< DTC/CIRCUIT DIAGNOSIS >

[VQ40DE FOR USA AND CANADA]

P2101 ELECTRIC THROTTLE CONTROL FUNCTION

Description

INFOID:000000012568440

NOTE:

If DTC P2101 is displayed with DTC P2100 or P2119, first perform the trouble diagnosis for DTC P2100 or P2119. Refer to [EC-907](#) or [EC-916](#).

Electric throttle control actuator consists of throttle control motor, throttle position sensor, etc.

The throttle control motor is operated by the ECM and it opens and closes the throttle valve.

The current opening angle of the throttle valve is detected by the throttle position sensor. The throttle position sensor provides feedback to the ECM, when opens/closes the throttle valve in response to driving conditions via the throttle control motor.

On Board Diagnosis Logic

INFOID:000000012568441

This self-diagnosis has the one trip detection logic.

DTC No.	Trouble diagnosis name	DTC detecting condition	Possible cause
P2101 2101	Electric throttle control performance	Electric throttle control function does not operate properly.	<ul style="list-style-type: none">• Harness or connectors (Throttle control motor circuit is open or shorted)• Electric throttle control actuator

FAIL-SAFE MODE

When the malfunction is detected, ECM enters fail-safe mode and the MIL illuminates.

Engine operating condition in fail-safe mode

ECM stops the electric throttle control actuator control, throttle valve is maintained at a fixed opening (approx. 5 degrees) by the return spring.

DTC Confirmation Procedure

INFOID:000000012568442

NOTE:

If DTC Confirmation Procedure has been previously conducted, always perform the following before conducting the next step.

1. Turn ignition switch OFF and wait at least 10 seconds.
2. Turn ignition switch ON.
3. Turn ignition switch OFF and wait at least 10 seconds.

TESTING CONDITION:

Before performing the following procedure, confirm that battery voltage is more than 11V when the engine is running.

1. Turn ignition switch ON and wait at least 2 seconds.
2. Start engine and let it idle for 5 seconds.
3. Check DTC.
4. If DTC is detected, go to [EC-910, "Diagnosis Procedure"](#).

Diagnosis Procedure

INFOID:000000012568443

1. CHECK GROUND CONNECTIONS

1. Turn ignition switch OFF
2. Loosen and retighten three ground screws on the body. Refer to [EC-631, "Ground Inspection"](#).

OK or NG

- OK >> GO TO 2.
- NG >> Repair or replace ground connections.

2. CHECK THROTTLE CONTROL MOTOR RELAY INPUT SIGNAL CIRCUIT-I

Check voltage between ECM terminal 1 and ground under the following conditions with CONSULT or tester.

ON BOARD REFUELING VAPOR RECOVERY (ORVR)

[VQ40DE FOR USA AND CANADA]

< DTC/CIRCUIT DIAGNOSIS >

NG >> Repair or replace one-way fuel valve with fuel tank. Refer to [FL-6, "Removal and Installation"](#).

11. CHECK ONE-WAY FUEL VALVE-II

1. Make sure that fuel is drained from the tank.
2. Remove fuel filler tube and hose.
3. Check one-way fuel valve for operation as follows.
When a stick is inserted, the valve should open, when removing stick it should close.

Do not drop any material into the tank.

OK or NG

OK >> **INSPECTION END**

NG >> Replace fuel filler tube or replace one-way fuel valve with fuel tank. Refer to [FL-6, "Removal and Installation"](#).

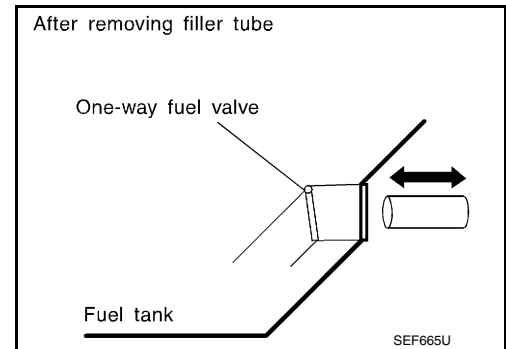

INFOID:000000012568497

Component Inspection

REFUELING EVAP VAPOR CUT VALVE

Ⓜ With CONSULT

1. Remove fuel tank. Refer to [FL-6, "Removal and Installation"](#).
2. Drain fuel from the tank as follows:
 - a. Remove fuel feed hose located on the fuel gauge retainer.
 - b. Connect a spare fuel hose, one side to fuel gauge retainer where the hose was removed and the other side to a fuel container.
 - c. Drain fuel using "FUEL PUMP RELAY" in "ACTIVE TEST" mode with CONSULT.
3. Check refueling EVAP vapor cut valve for being stuck to close as follows.
Blow air into the refueling EVAP vapor cut valve (from the end of EVAP/ORVR line hose), and check that the air flows freely into the tank.
4. Check refueling EVAP vapor cut valve for being stuck to open as follows.
 - a. Connect vacuum pump to hose end.
 - b. Remove fuel gauge retainer with fuel gauge unit.
Always replace O-ring with new one.
 - c. Turn fuel tank upside down.
 - d. Apply vacuum pressure to hose end [-13.3 kPa (-100 mmHg, -3.94 inHg)] with fuel gauge retainer remaining open and check that the pressure is applicable.

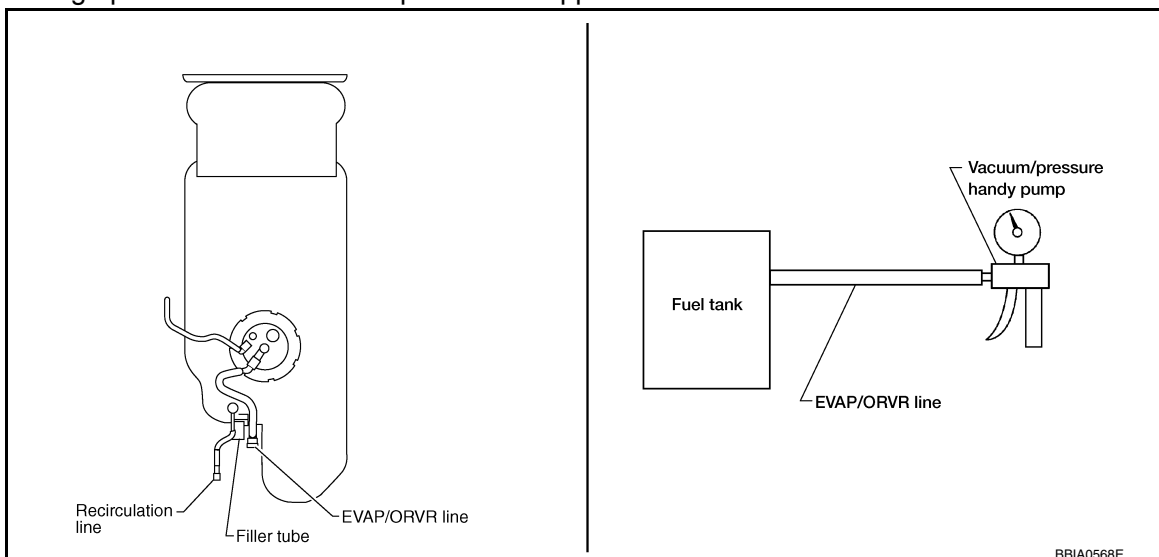

ⓧ Without CONSULT

DIAGNOSIS SYSTEM (ECM)

< SYSTEM DESCRIPTION >

[VQ40DE FOR MEXICO]

DIAGNOSIS SYSTEM (ECM)

DIAGNOSIS DESCRIPTION

DIAGNOSIS DESCRIPTION : 1st Trip Detection Logic and Two Trip Detection Logic

INFOID:000000012568544

When a malfunction is detected for the first time, 1st trip DTC and 1st trip Freeze Frame data are stored in the ECM memory. The MIL will not illuminate at this stage. <1st trip>

If the same malfunction is detected again during the next drive, the DTC and Freeze Frame data are stored in the ECM memory, and the MIL illuminates. The MIL illuminates at the same time when the DTC is stored. <2nd trip> The "trip" in the "Two Trip Detection Logic" means a driving mode in which self-diagnosis is performed during vehicle operation. Specific on board diagnostic items will cause the ECM to illuminate or blink the MIL, and store DTC and Freeze Frame data, even in the 1st trip, as shown below.

×: Applicable —: Not applicable

Items	MIL				DTC		1st trip DTC	
	1st trip		2nd trip		1st trip displaying	2nd trip displaying	1st trip displaying	2nd trip displaying
	Blinking	Illuminated	Blinking	Illuminated				
Misfire (Possible three way catalyst damage) — DTC: P0300 – P0306 is being detected	×	—	—	—	—	—	×	—
Misfire (Possible three way catalyst damage) — DTC: P0300 – P0306 is being detected	—	—	×	—	—	×	—	—
One trip detection diagnoses (Refer to EC-1053, "DTC Index" .)	—	×	—	—	×	—	—	—
Except above	—	—	—	×	—	×	×	—

DIAGNOSIS DESCRIPTION : DTC and Freeze Frame Data

INFOID:000000012568545

DTC AND 1ST TRIP DTC

The 1st trip DTC (whose number is the same as the DTC number) is displayed for the latest self-diagnostic result obtained. If the ECM memory was cleared previously, and the 1st trip DTC did not recur, the 1st trip DTC will not be displayed.

If a malfunction is detected during the 1st trip, the 1st trip DTC is saved in the ECM memory. The MIL will not light up (two trip detection logic). If the same malfunction is not detected in the 2nd trip (meeting the required driving pattern), the 1st trip DTC is cleared from the ECM memory. If the same malfunction is detected in the 2nd trip, both the 1st trip DTC and DTC are saved in the ECM memory and the MIL lights up. In other words, the DTC is stored in the ECM memory and the MIL lights up when the same malfunction occurs in two consecutive trips. If a 1st trip DTC is stored and a non-diagnostic operation is performed between the 1st and 2nd trips, only the 1st trip DTC will continue to be stored. For malfunctions that blink or light up the MIL during the 1st trip, the DTC and 1st trip DTC are stored in the ECM memory.

For malfunctions in which 1st trip DTCs are displayed, refer to [EC-1053, "DTC Index"](#). These items are required by legal regulations to continuously monitor the system/component. In addition, the items monitored non-continuously are also displayed on CONSULT.

1st trip DTC is specified in Service \$07 of SAE J1979/ISO 15031-5. 1st trip DTC detection occurs without illuminating the MIL and therefore does not warn the driver of a malfunction.

When a 1st trip DTC is detected, check, print out or write down and erase (1st trip) DTC and Freeze Frame data as specified in Work Flow procedure Step 2, refer to [EC-1085, "Trouble Diagnosis Introduction"](#). Then perform DTC Confirmation Procedure or Component Function Check to try to duplicate the malfunction. If the malfunction is duplicated, the item requires repair.

FREEZE FRAME DATA AND 1ST TRIP FREEZE FRAME DATA

The ECM records the driving conditions such as fuel system status, calculated load value, engine coolant temperature, short term fuel trim, long term fuel trim, engine speed, vehicle speed, absolute throttle position, base fuel schedule and intake air temperature at the moment a malfunction is detected.

Data which are stored in the ECM memory, along with the 1st trip DTC, are called 1st trip freeze frame data. The data, stored together with the DTC data, are called freeze frame data and displayed on CONSULT or GST. The 1st trip freeze frame data can only be displayed on the CONSULT screen.

ENGINE CONTROL SYSTEM

< WIRING DIAGRAM >

[VQ40DE FOR MEXICO]

Connector No.	E120
Connector Name	IPDM E/R (INTELLIGENT POWER DISTRIBUTION MODULE ENGINE ROOM)
Connector Color	WHITE



Terminal No.	Color of Wire	Signal Name
20	BR	MOTOR FAN 1
24	P	MOTOR FAN 2

Connector No.	E121
Connector Name	IPDM E/R (INTELLIGENT POWER DISTRIBUTION MODULE ENGINE ROOM)
Connector Color	BROWN

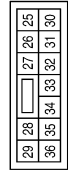

Terminal No.	Color of Wire	Signal Name
30	R/B	ECM BAT

Connector No.	E122
Connector Name	IPDM E/R (INTELLIGENT POWER DISTRIBUTION MODULE ENGINE ROOM)
Connector Color	WHITE

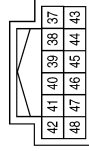

Terminal No.	Color of Wire	Signal Name
38	B	GND (SIGNAL)
39	L	CAN-H
40	P	CAN-L
46	V	FUEL PUMP RLY CONT
47	W	ETC RLY CONT (FOR MEXICO)

Connector No.	E124
Connector Name	IPDM E/R (INTELLIGENT POWER DISTRIBUTION MODULE ENGINE ROOM)
Connector Color	BLACK



Terminal No.	Color of Wire	Signal Name
59	B	GND (POWER)

Connector No.	E152
Connector Name	WIRE TO WIRE
Connector Color	WHITE

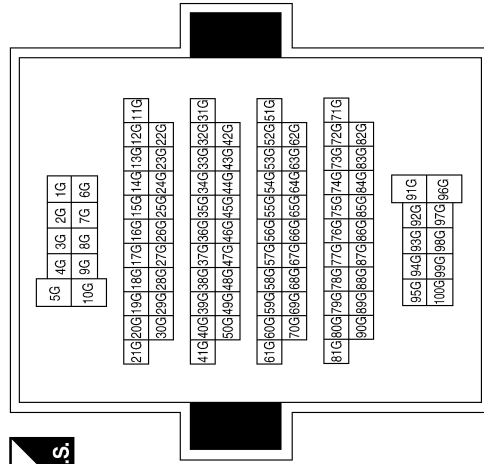

Terminal No.	Color of Wire	Signal Name
31G	P	-
32G	L	-
36G	G	-
61G	W/R	-
62G	B	- (FOR MEXICO)
63G	SB	-
68G	W	- (FOR MEXICO)

A
EC
C
D
E
F
G
H
I
J
K
L
M
N
O
P

P0075, P0081 IVT CONTROL SOLENOID VALVE

< DTC/CIRCUIT DIAGNOSIS >

[VQ40DE FOR MEXICO]

P0075, P0081 IVT CONTROL SOLENOID VALVE

Component Description

INFOID:000000012568599

Intake valve timing control solenoid valve is activated by ON/OFF pulse duty (ratio) signals from the ECM.
 The intake valve timing control solenoid valve changes the oil amount and direction of flow through intake valve timing control unit or stops oil flow.
 The longer pulse width advances valve angle.
 The shorter pulse width retards valve angle.
 When ON and OFF pulse widths become equal, the solenoid valve stops oil pressure flow to fix the intake valve angle at the control position.

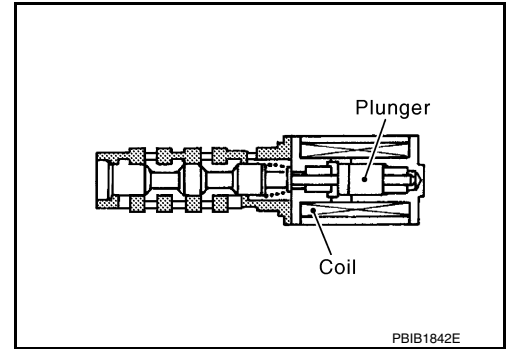

On Board Diagnosis Logic

INFOID:000000012568600

DTC No.	Trouble diagnosis name	DTC detecting condition	Possible cause
P0075 0075 (Bank 1)	Intake valve timing control solenoid valve circuit	An improper voltage is sent to the ECM through intake valve timing control solenoid valve.	<ul style="list-style-type: none"> • Harness or connectors (Intake valve timing control solenoid valve circuit is open or shorted.) • Intake valve timing control solenoid valve
P0081 0081 (Bank 2)			

DTC Confirmation Procedure

INFOID:000000012568601

1. If DTC Confirmation Procedure has been previously conducted, always perform the following before conducting the next step.
 - a. Turn ignition switch OFF and wait at least 10 seconds.
 - b. Turn ignition switch ON.
 - c. Turn ignition switch OFF and wait at least 10 seconds.
2. Start engine and let it idle for 5 seconds.
3. Check 1st trip DTC.
4. If 1st trip DTC is detected, go to [EC-1130, "Diagnosis Procedure"](#).

Diagnosis Procedure

INFOID:000000012568602

1. CHECK INTAKE VALVE TIMING CONTROL SOLENOID VALVE POWER SUPPLY CIRCUIT

1. Turn ignition switch OFF.
2. Disconnect intake valve timing control solenoid valve harness connector.

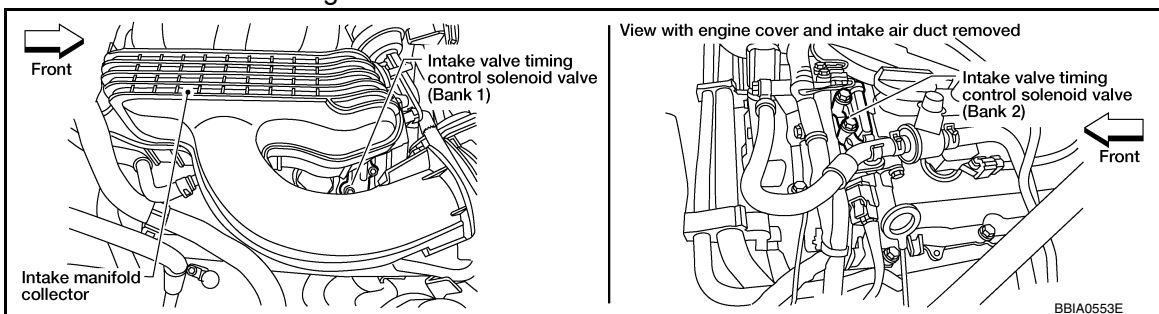

3. Turn ignition switch ON.

3. PERFORM DTC CONFIRMATION PROCEDURE

With CONSULT

1. Turn ignition switch ON and select "DATA MONITOR" mode with CONSULT.
 2. Start the engine and warm it up to the normal operating temperature.
 3. Turn ignition switch OFF and wait at least 10 seconds.
 4. Turn ignition switch ON.
 5. Turn ignition switch OFF and wait at least 10 seconds.
 6. Start the engine and keep the engine speed between 3,500 and 4,000 rpm for at least 1 minute under no load.
 7. Let engine idle for 1 minute.
 8. Make sure that "COOLAN TEMP/S" indicates more than 70°C (158°F).
 9. Drive the vehicle in a proper gear or position at 60 km/h (38 MPH) and maintain the speed.
- CAUTION:**
Always drive vehicle at a safe speed.
10. Release the accelerator pedal fully at least 5 seconds.
- CAUTION:**
- **Make it the condition that engine brake operates.**
 - **Always drive vehicle safely.**
 - **Never apply brake when releasing the accelerator pedal.**
11. Repeat step 9 and 10 at least 8 times.
 12. Check the following item of "DATA MONITOR".

DTC	Data monitor item	Status
P0139	HO2 S2 DIAG1 (B1)	CMPLT
	HO2 S2 DIAG2 (B1)	
P0159	HO2 S2 DIAG1 (B2)	
	HO2 S2 DIAG2 (B2)	

Is "CMPLT" displayed on CONSULT screen?

YES >> GO TO 6.

NO-1: "CMPLT" are not displayed on DIAG 1>>Perform DTC confirmation procedure again.

NO-2: "CMPLT" are not displayed on DIAG 2>>GO TO 4.

4. PERFORM DTC WORK SUPPORT

1. Open engine hood.
 2. Select "HO2S2 (B1) P0139" or "HO2S2 (B2) P0159" of "HO2S2" in "DTC WORK SUPPORT" mode with CONSULT.
 3. Start the engine and follow the instruction of CONSULT display.
- NOTE:**
 It will take at most 10 minutes until "COMPLETED" is displayed.

Is "COMPLETED" displayed on CONSULT screen?

YES >> GO TO 6.

NO >> GO TO 5.

5. PERFORM DTC CONFIRMATION PROCEDURE AGAIN

1. Turn ignition switch OFF and leave the vehicle in a cool place (soak the vehicle).
2. Perform DTC confirmation procedure again.

>> GO TO 3.

6. PERFORM SELF-DIAGNOSIS

With CONSULT

Perform ECM self-diagnosis.

Is DTC "P0139" or "P0159" detected?

YES >> Proceed to [EC-1186, "Diagnosis Procedure"](#).

NO >> INSPECTION END

CLICK HERE TO **DOWNLOAD** THE COMPLETE MANUAL

- Thank you very much for reading the preview of the manual.
- You can download the complete manual from: www.heydownloads.com by clicking the link below



- Please note: If there is no response to CLICKING the link, please download this PDF first and then click on it.

CLICK HERE TO **DOWNLOAD** THE COMPLETE MANUAL

P0442 EVAP CONTROL SYSTEM

< DTC/CIRCUIT DIAGNOSIS >

[VQ40DE FOR MEXICO]

Condition VENT CONTROL/V	Air passage continuity between (A) and (B)
ON	No
OFF	Yes

Operation takes less than 1 second.

If NG, replace EVAP canister vent control valve.

If OK, go to next step.

7. Clean the air passage (portion **A** to **B**) of EVAP canister vent control valve using an air blower.
8. Perform step 6 again.
9. If NG, replace EVAP canister vent control valve.

⊗ Without CONSULT

1. Remove EVAP canister vent control valve from EVAP canister.
2. Check portion **B** of EVAP canister vent control valve for being rusted.

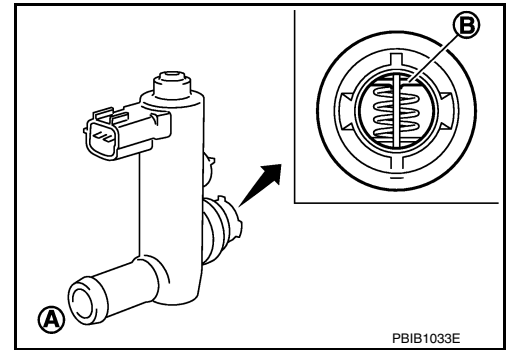

3. Check air passage continuity and operation delay time under the following conditions.

Check new O-ring is installed properly.

Condition	Air passage continuity between (A) and (B)
12V direct current supply between terminals 1 and 2	No
OFF	Yes

Operation takes less than 1 second.

If NG, go to next step.

4. Clean the air passage (portion **A** to **B**) of EVAP canister vent control valve using an air blower.
5. Perform step 3 again.
6. If NG, replace EVAP canister vent control valve.

DRAIN FILTER

1. Check visually for insect nests in the drain filter air inlet.
2. Check visually for cracks or flaws in the appearance.
3. Check visually for cracks or flaws in the hose.

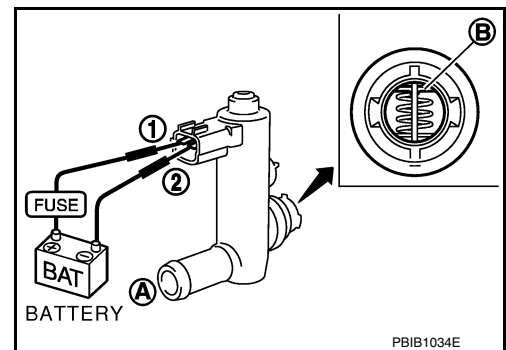

P1550 BATTERY CURRENT SENSOR

< DTC/CIRCUIT DIAGNOSIS >

[VQ40DE FOR MEXICO]

P1550 BATTERY CURRENT SENSOR

Component Description

INFOID:000000012568782

The power generation voltage variable control enables fuel consumption to be decreased by reducing the engine load which is caused by the power generation of the generator. The battery current sensor is installed to the battery cable at the negative terminal. The sensor measures the charging/discharging current of the battery. Based on the sensor signal, ECM judges whether or not the power generation voltage variable control is performed. When performing the power generation voltage variable control, ECM calculates the target power generation voltage based on the sensor signal. And ECM sends the calculated value as the power generation command value to IPDM E/R. For the details of the power generation voltage variable control, refer to [CHG-9, "System Description"](#).

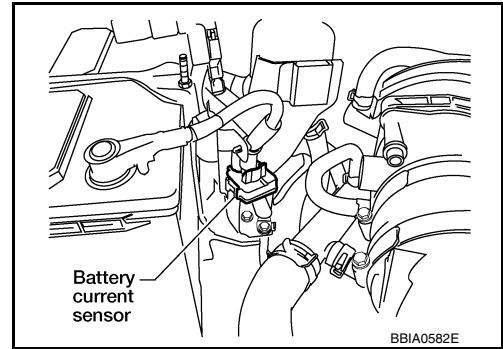

CAUTION:

Never connect the electrical component or the ground wire directly to the battery terminal. The connection causes the malfunction of the power generation voltage variable control, and then battery discharge may occur.

On Board Diagnosis Logic

INFOID:000000012568783

The MIL will not illuminate for this diagnosis.

NOTE:

If DTC P1550 is displayed with DTC P0643, first perform the trouble diagnosis for DTC P0643. Refer to [EC-1280](#).

DTC No.	Trouble diagnosis name	DTC detecting condition	Possible cause
P1550 1550	Battery current sensor circuit range/performance	The output voltage of the battery current sensor remains within the specified range while engine is running.	<ul style="list-style-type: none">• Harness or connectors (The sensor circuit is open or shorted.)• Battery current sensor

DTC Confirmation Procedure

INFOID:000000012568784

NOTE:

If DTC Confirmation Procedure has been previously conducted, always perform the following before conducting the next step.

1. Turn ignition switch OFF and wait at least 10 seconds.
2. Turn ignition switch ON.
3. Turn ignition switch OFF and wait at least 10 seconds.

TESTING CONDITION:

Before performing the following procedure, confirm that battery voltage is more than 8V at idle.

1. Start engine and wait at least 10 seconds.
2. Check 1st trip DTC.
3. If 1st trip DTC is detected, go to [EC-1295, "Diagnosis Procedure"](#).

Diagnosis Procedure

INFOID:000000012568785

1. CHECK GROUND CONNECTIONS

1. Turn ignition switch OFF.
2. Loosen and retighten three ground screws on the body.

P2127, P2128 APP SENSOR

< DTC/CIRCUIT DIAGNOSIS >

[VQ40DE FOR MEXICO]

- Loosen and retighten three ground screws on the body, Refer to [EC-1117, "Ground Inspection"](#).

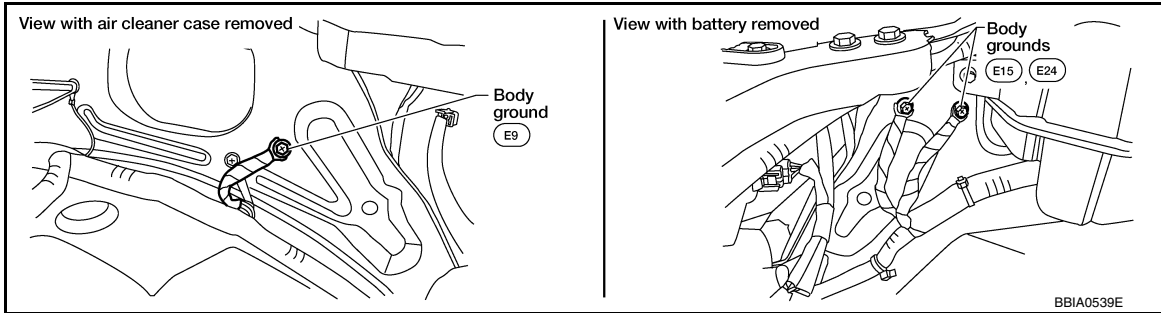

OK or NG

- OK >> GO TO 2.
- NG >> Repair or replace ground connections.

2. CHECK APP SENSOR 2 POWER SUPPLY CIRCUIT-I

- Disconnect accelerator pedal position (APP) sensor harness connector.

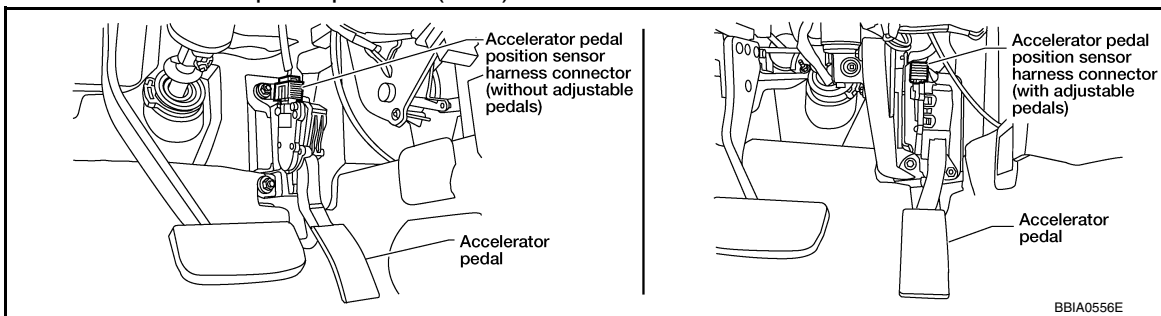

- Turn ignition switch ON.
- Check voltage between APP sensor terminal 1 and ground with CONSULT or tester.

Voltage: Approximately 5V

OK or NG

- OK >> GO TO 7.
- NG >> GO TO 3.

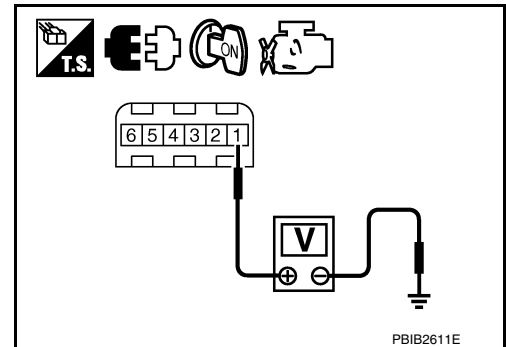

3. CHECK APP SENSOR 2 POWER SUPPLY CIRCUIT-II

- Turn ignition switch OFF.
- Disconnect ECM harness connector.
- Check harness continuity between APP sensor terminal 1 and ECM terminal 91. Refer to wiring diagram.

Continuity should exist.

OK or NG

- OK >> GO TO 4.
- NG >> Repair open circuit.

4. CHECK THROTTLE POSITION SENSOR 2 POWER SUPPLY CIRCUIT-III

Check harness for short to power and short to ground, between the following terminals.

ECM terminal	Sensor terminal
91	APP sensor terminal 1
47	Electric throttle control actuator terminal 2

SERVICE DATA AND SPECIFICATIONS (SDS)

< SERVICE DATA AND SPECIFICATIONS (SDS)

[VQ40DE FOR MEXICO]

SERVICE DATA AND SPECIFICATIONS (SDS)

SERVICE DATA AND SPECIFICATIONS (SDS)

Fuel Pressure

INFOID:0000000012568903

Fuel pressure at idling kPa (kg/cm ² , psi)	Approximately 350 (3.57, 51)
--	------------------------------

Idle Speed and Ignition Timing

INFOID:0000000012568904

Target idle speed	No load* [in P or N position]	625 ± 50 rpm
Air conditioner: ON	In P or N position	625 rpm or more
Ignition timing	In P or N position	15 ± 5° BTDC

*: Under the following conditions:

- Air conditioner switch: OFF
- Electric load: OFF (Lights, heater fan & rear window defogger)
- Steering wheel: Kept in straight-ahead position

Calculated Load Value

INFOID:0000000012568905

Condition	Calculated load value% (Using CONSULT or GST)
At idle	5 - 35
At 2,500 rpm	5 - 35

Mass Air Flow Sensor

INFOID:0000000012568906

Supply voltage	Battery voltage (11 - 14V)
Output voltage at idle	0.9 - 1.2*V
Mass air flow (Using CONSULT or GST)	2.0 - 6.0 g/s at idle* 7.0 - 20.0 g/s at 2,500 rpm*

*: Engine is warmed up to normal operating temperature and running under no load.

Intake Air Temperature Sensor

INFOID:0000000012568907

Temperature °C (°F)	Resistance kΩ
25 (77)	1.800 - 2.200

Engine Coolant Temperature Sensor

INFOID:0000000012568908

Temperature °C (°F)	Resistance kΩ
20 (68)	2.1 - 2.9
50 (122)	0.68 - 1.00
90 (194)	0.236 - 0.260

Air Fuel Ratio (A/F) Sensor 1 Heater

INFOID:0000000012568909

Resistance [at 25°C (77°F)]	1.80 - 2.44Ω
-----------------------------	--------------

TIMING CHAIN

[QR25DE]

< REMOVAL AND INSTALLATION >

- When inserting crankshaft pulley with a plastic hammer, tap on its center portion (not circumference).

CAUTION:

Do not damage front oil seal lip section.

21. Tighten crankshaft pulley bolt.
 - Secure crankshaft pulley using suitable tool, and tighten crankshaft pulley bolt.
- a. Apply new engine oil to thread and seat surfaces of crankshaft pulley bolt.
- b. Tighten crankshaft pulley bolt.

Crankshaft pulley bolt : 42.1 N·m (4.3 kg·m, 31 ft·lb)

- c. Put a paint mark on crankshaft pulley, mating with any one of six easy to recognize angle marks on bolt flange.
- d. Turn another 60° degrees clockwise (angle tightening).
 - Check the tightening angle with movement of one angle mark.

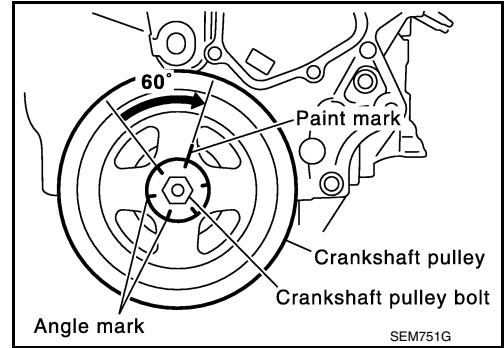

22. Installation of the remaining components is in the reverse order of removal.

INSPECTION AFTER INSTALLATION

- Before starting engine, check oil/fluid levels including engine coolant and engine oil. If less than required quantity, fill to the specified level. Refer to [MA-18. "FOR USA AND CANADA : Fluids and Lubricants"](#) (United States and Canada).
- Use procedure below to check for fuel leakage.
- Turn ignition switch ON (with engine stopped). With fuel pressure applied to fuel piping, check for fuel leakage at connection points.
- Start engine. With engine speed increased, check again for fuel leakage at connection points.
- Run engine to check for unusual noise and vibration.

NOTE:

If hydraulic pressure inside timing chain tensioner drops after removal and installation, slack in the guide may generate a pounding noise during and just after engine start. However, this is normal. Noise will stop after hydraulic pressure rises.

- Warm up engine thoroughly to make sure there is no leakage of fuel, exhaust gas, or any oils/fluids including engine oil and engine coolant.
- Bleed air from passages in lines and hoses, such as in cooling system.
- After cooling down engine, again check oil/fluid levels including engine oil and engine coolant. Refill to specified level, if necessary.
- Summary of the inspection items:

Item		Before starting engine	Engine running	After engine stopped
Engine coolant		Level	Leakage	Level
Engine oil		Level	Leakage	Level
Transmission/transaxle fluid	A/T and CVT Models	Leakage	Level/Leakage	Leakage
	M/T Models	Level/Leakage	Leakage	Level/Leakage
Other oils and fluids*		Level	Leakage	Level
Fuel		Leakage	Leakage	Leakage
Exhaust gas		—	Leakage	—

*Power steering fluid, brake fluid, etc.

SERVICE DATA AND SPECIFICATIONS (SDS)

< SERVICE DATA AND SPECIFICATIONS (SDS)

[QR25DE]

SERVICE DATA AND SPECIFICATIONS (SDS)

SERVICE DATA AND SPECIFICATIONS (SDS)

Standard and Limit

INFOID:0000000012567419

A

EM

GENERAL SPECIFICATIONS

Cylinder arrangement		In-line 4
Displacement	cm ³ (cu in)	2,488 (151.82)
Bore and stroke	mm (in)	89.0 x 100.0 (3.504 x 3.937)
Valve arrangement		DOHC
Firing order		1-3-4-2
Number of piston rings	Compression	2
	Oil	1
Compression ratio		9.5
Compression pressure kPa (kg/cm ² , psi) / 250 rpm	Standard	1,304 (13.3, 189)
	Minimum	1,108 (11.3, 161)
	Differential limit between cylinders	100 (1.0, 14)

C

D

E

F

G

DRIVE BELT

Tension of drive belt	Auto adjustment by auto-tensioner
-----------------------	-----------------------------------

H

EXHAUST MANIFOLD AND THREE WAY CATALYST ASSEMBLY

Unit: mm (in)

Item	Limit
Surface distortion	0.3 (0.012)

I

J

SPARK PLUG

Make	NGK
Standard type*	PLZKAR6A-11
Gap (nominal)	1.1 mm (0.043 in)

K

L

*: Always check with the Parts Department for the latest parts information.

CYLINDER HEAD

Unit: mm (in)

Items	Limit
Head surface distortion	0.1 (0.004)
Items	Standard

M

N

O

P

FUEL INJECTOR AND FUEL TUBE

< REMOVAL AND INSTALLATION >

[VQ40DE]

FUEL INJECTOR AND FUEL TUBE

Exploded View

INFOID:000000012567459

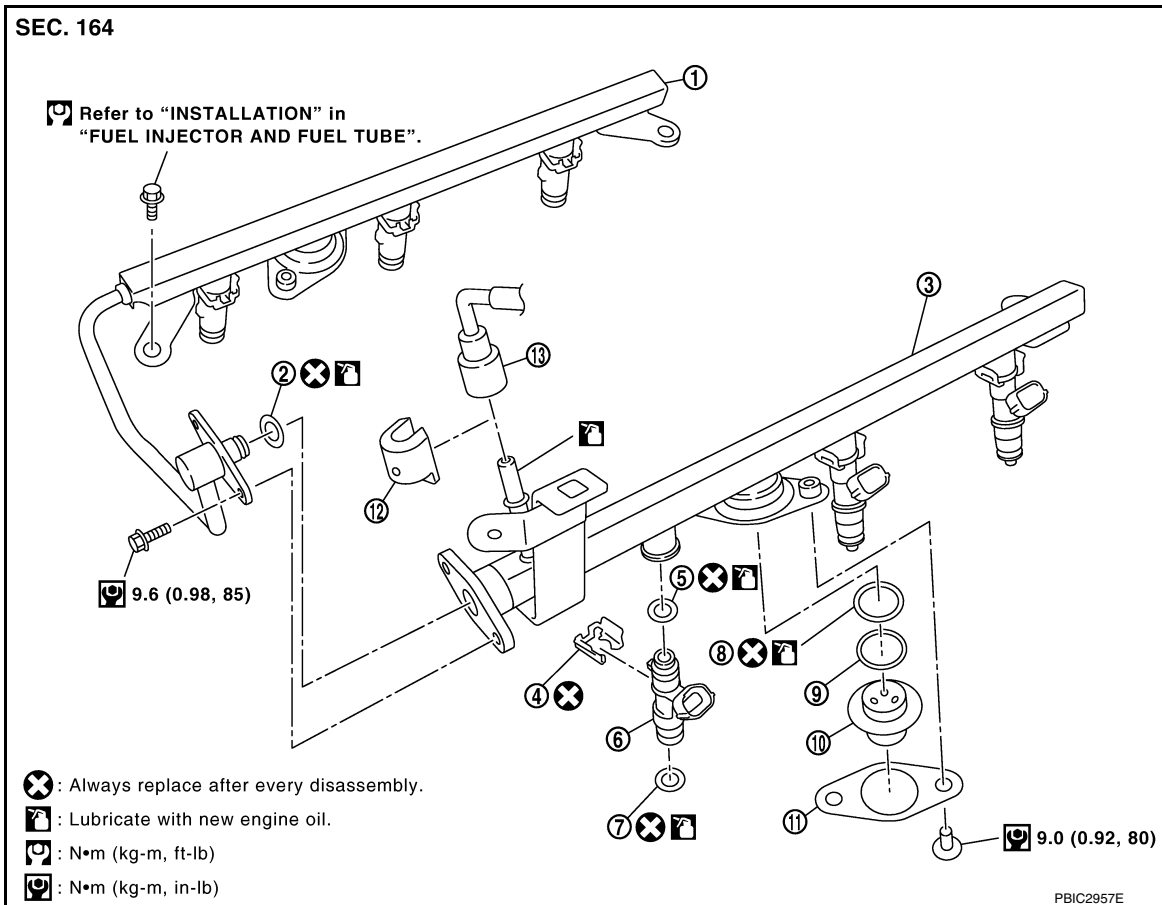

- | | | |
|--------------------|---------------------|-------------------------|
| 1. Fuel tube (RH) | 2. O-ring | 3. Fuel tube (LH) |
| 4. Clip | 5. O-ring (blue) | 6. Fuel injector |
| 7. O-ring (brown) | 8. O-ring | 9. Spacer |
| 10. Fuel damper | 11. Fuel damper cap | 12. Quick connector cap |
| 13. Fuel feed hose | | |

Removal and Installation

INFOID:000000012567460

WARNING:

- Put a "CAUTION FLAMMABLE" sign in the workshop.
- Be sure to work in a well ventilated area and furnish workshop with a CO₂ fire extinguisher.
- Do not smoke while servicing fuel system. Keep open flames and sparks away from the work area.
- To avoid the danger of being scalded, do not drain engine coolant when engine is hot.

CAUTION:

Do not remove or disassemble parts unless instructed.

NOTE:

When removing components such as hoses, tubes/lines, etc., cap or plug openings to prevent fluid from spilling.

REMOVAL

1. Release the fuel pressure. Refer to [EC-981, "Fuel Pressure Check"](#).
2. Disconnect the battery negative terminal. Refer to [PG-89, "Removal and Installation"](#).
3. Remove the intake manifold collector. Refer to [EM-143, "Removal and Installation"](#).

CAUTION:

ENGINE ASSEMBLY

< UNIT REMOVAL AND INSTALLATION >

[VQ40DE]

- When lifting vehicle, ensure that the front and rear of the vehicle are well balanced.

CAUTION:

- Always be careful to work safely, avoid forceful or uninstructed operations.
- Do not start working until exhaust system and engine coolant are cooled sufficiently.
- If items or work required are not covered by the engine section, follow the procedures in the applicable sections.
- Always use the support point specified for lifting.
- Use either 2-point lift type or separate type lift. If board-on type is used for unavoidable reasons, support the rear axle jacking point with transmission jack or similar tool before starting work, in preparation for the backward shift of center of gravity.
- For supporting points for lifting and jacking point at rear axle. Refer to [GI-34, "Garage Jack and Safety Stand"](#).

NOTE:

When removing components such as hoses, tubes/lines, etc., cap or plug openings to prevent fluid from spilling.

REMOVAL

Preparation

1. Remove engine under cover (if equipped). Refer to [EXT-15, "Removal and Installation"](#).
2. Drain engine oil. Refer to [LU-23, "Changing Engine Oil"](#).
3. Remove engine oil filter.
4. Drain engine coolant. Refer to [CO-40, "Changing Engine Coolant"](#).
5. Release fuel pressure. Refer to [EC-981, "Fuel Pressure Check"](#).
6. Remove the engine hood. Refer to [DLK-129, "Removal and Installation of Hood Assembly"](#).
7. Disconnect the battery negative terminal. Refer to [PG-89, "Removal and Installation"](#).
8. Remove engine room cover using power tool. Refer to [EM-141, "Removal and Installation"](#).
9. Remove the air duct and resonator assembly and air cleaner case assembly. Refer to [EM-142, "Removal and Installation"](#).
10. Disconnect brake booster vacuum hose between vehicle and engine and set it aside.
11. Remove front grille. Refer to [EXT-23, "Removal and Installation"](#).
12. Remove the radiator assembly and hoses. Refer to [CO-44, "Removal and Installation"](#).
13. Remove the drive belts. Refer to [EM-130, "Removal and Installation"](#).
14. Remove the engine cooling fan and shroud. Refer to [CO-47, "Removal and Installation \(Crankshaft driven type\)"](#).
15. Disconnect the engine room harness from the engine side and set it aside.
16. Disconnect the engine harness grounds.
17. Reposition the reservoir tank for power steering from engine compartment and move it aside.
18. Disconnect power steering oil pump from engine. Move it from its location and secure with a rope. Refer to [ST-20, "Removal and Installation"](#).
19. Remove the A/C compressor bolts and reposition the A/C compressor. Refer to [HA-25, "Removal and Installation for Compressor"](#).
20. Disconnect EVAP line.
21. Disconnect the fuel hose at the engine side connection. Refer to [EM-164, "Removal and Installation"](#).
22. Disconnect the heater hoses at cowl.
23. Remove the A/T oil level indicator and indicator tube.
24. Remove front final drive assembly (4WD models). Refer to [DLN-191, "Removal and Installation"](#).
25. Remove three way catalyst. Refer to [EM-148, "Removal and Installation \(Three Way Catalyst\)"](#).

PREPARATION

< PREPARATION >

PREPARATION

PREPARATION

Special Service Tool

INFOID:0000000012563608

The actual shape of the tools may differ from those illustrated here.

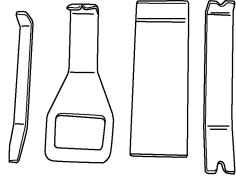

Tool number (TechMate No.) Tool name	Description
— (J-46534) Trim Tool Set	Removing trim components



AWJIA0483ZZ

BCM (BODY CONTROL MODULE)

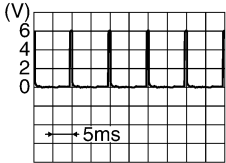
< ECU DIAGNOSIS INFORMATION >

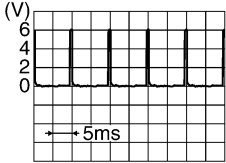
Terminal	Wire color	Item	Signal input/output	Measuring condition		Reference value or waveform (Approx.)
				Ignition switch	Operation or condition	
1	BR	Ignition keyhole illumination	Output	OFF	Door is locked (SW OFF)	Battery voltage
					Door is unlocked (SW ON)	0V
2	P	Combination switch input 5	Input	ON	Lighting, turn, wiper OFF Wiper dial position 4	 <p style="text-align: right; font-size: small;">SKIA5291E</p>
3	SB	Combination switch input 4	Input	ON	Lighting, turn, wiper OFF Wiper dial position 4	 <p style="text-align: right; font-size: small;">SKIA5292E</p>
4	V	Combination switch input 3	Input	ON	Lighting, turn, wiper OFF Wiper dial position 4	 <p style="text-align: right; font-size: small;">SKIA5291E</p>
5	L	Combination switch input 2	Input	ON	Lighting, turn, wiper OFF Wiper dial position 4	 <p style="text-align: right; font-size: small;">SKIA5292E</p>
6	R	Combination switch input 1				
7	GR	Front door lock assembly LH (key cylinder switch) unlock	Input	OFF	ON (open, 2nd turn)	Momentary 1.5V
8	SB	Front door lock assembly LH (key cylinder switch) lock	Input		On (open)	Momentary 1.5V
				OFF (closed)	0V	
9	LG	Brake sw	Input	OFF	OFF (brake pedal is not depressed)	0V
					ON (brake pedal is depressed)	Battery voltage
11	G/B	Ignition switch (ACC or ON)	Input	ACC or ON	Ignition switch ACC or ON	Battery voltage
12	LG	Front door switch RH (All)	Input	OFF	ON (open)	0V
		Rear door switch upper RH (King Cab)			OFF (closed)	Battery voltage
		Rear door switch lower RH (King Cab)				

A
B
C
D
E
F
G
H
I
J
K
L
M
N
O
P

EXL

BACK-UP LAMP

< WIRING DIAGRAM >

BACK-UP LAMP CONNECTORS

Connector No.	E5
Connector Name	WIRE TO WIRE
Connector Color	WHITE

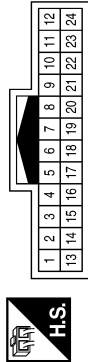

Terminal No.	Color of Wire	Signal Name
9	LG	-
10	W/G	-
11	SB	-

Connector No.	E41
Connector Name	WIRE TO WIRE
Connector Color	BLACK

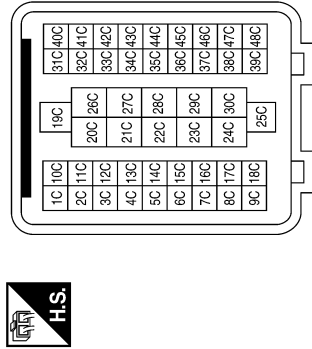

Terminal No.	Color of Wire	Signal Name
33C	SB	-
35C	B	-

Connector No.	E45
Connector Name	BACK-UP LAMP RELAY (WITH A/T)
Connector Color	BROWN



Terminal No.	Color of Wire	Signal Name
1	LG	-
2	W/G	-
3	SB	-
5	W/G	-
6	Y	-
7	W/G	-

Connector No.	E119
Connector Name	IPDM E/R (INTELLIGENT POWER DISTRIBUTION MODULE ENGINE ROOM)
Connector Color	WHITE

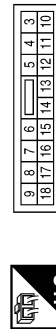

Terminal No.	Color of Wire	Signal Name
16	W/G	REVERSE LAMP

Connector No.	E121
Connector Name	IPDM E/R (INTELLIGENT POWER DISTRIBUTION MODULE ENGINE ROOM)
Connector Color	BROWN

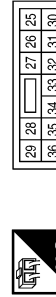

Terminal No.	Color of Wire	Signal Name
27	W/G	T TOW REV LAMP

Connector No.	F9
Connector Name	A/T ASSEMBLY
Connector Color	GREEN



Terminal No.	Color of Wire	Signal Name
7	LG	-

REAR BUMPER

< REMOVAL AND INSTALLATION >

REAR BUMPER

Removal and Installation

INFOID:000000012564200

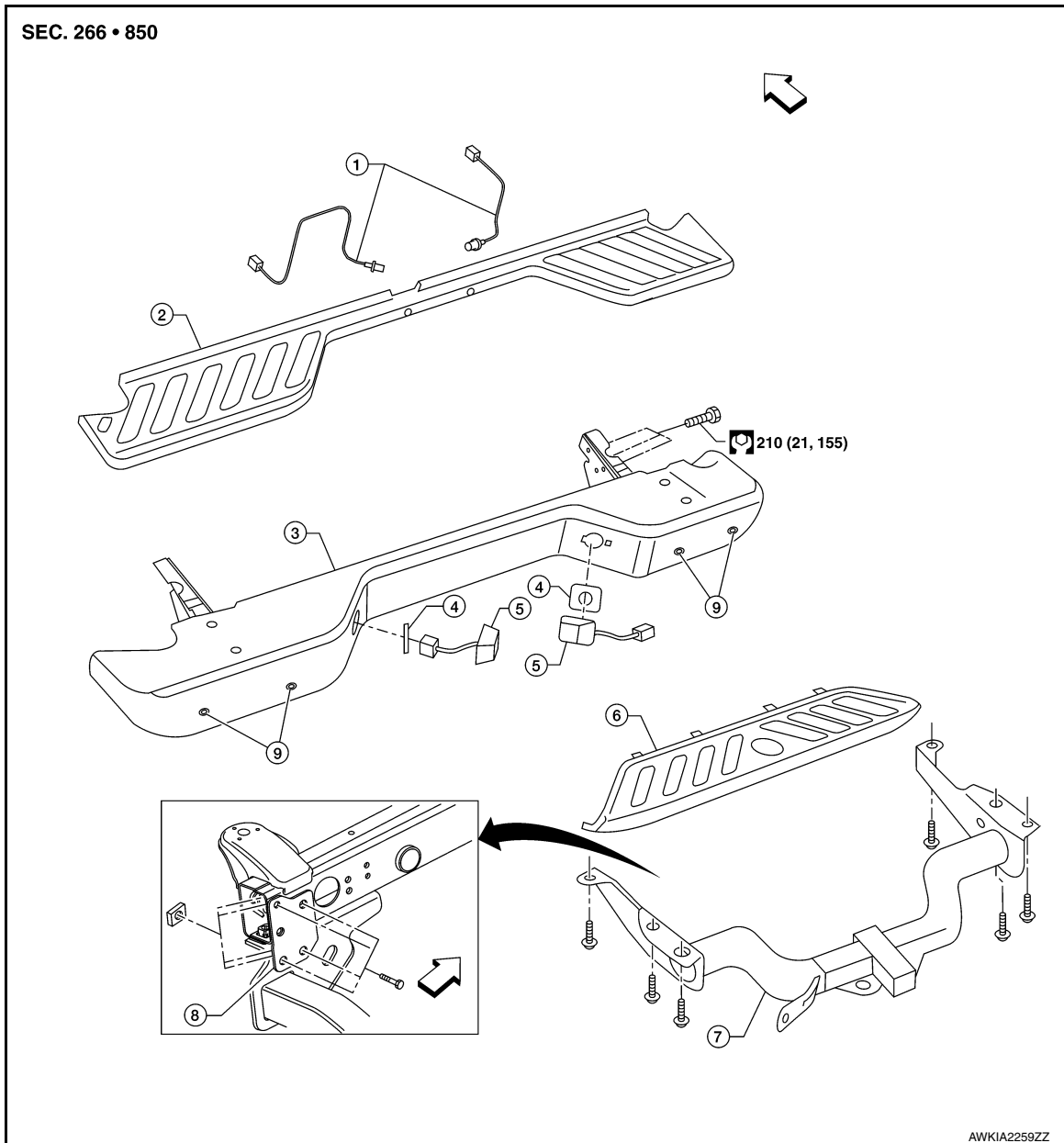

- | | | |
|---------------------------------|--|-------------------------------|
| 1. License lamp harness (RH/LH) | 2. Upper step pad | 3. Rear bumper |
| 4. License lamp gasket | 5. License lamp (RH/LH) | 6. Lower step pad |
| 7. Tow hitch (if equipped) | 8. Tow hitch reinforcement (if equipped) | 9. Sonar sensor (if equipped) |

⇐ Front

REMOVAL

NOTE:



It is not necessary to remove the tow hitch (if equipped) to service the rear bumper.

1. Remove upper and lower step pads.
2. Disconnect the harness connector from the sonar sensor (if equipped).
3. Disconnect license lamp harness (RH/LH).
4. Release clips from license lamp (RH/LH), then remove lamps from rear bumper.

A
B
C
D
E
F
G
H
I
J
EXT
L
M
N
O
P

PREPARATION

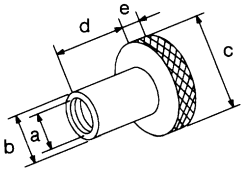
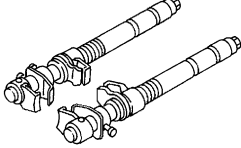
< PREPARATION >

Tool name	Description
<p>Attachment wheel alignment</p>  <p style="text-align: right;">NT148</p>	<p>Measuring wheel alignment</p> <p>a: Screw M24 x 1.5 pitch b: 35 mm (1.38 in) dia. c: 65 mm (2.56 in) dia. d: 56 mm (2.20 in) e: 12 mm (0.47 in)</p>
<p>Spring compressor</p>  <p style="text-align: right;">NT717</p>	<p>Removing and installing coil spring</p>
<p>Power tool</p>  <p style="text-align: right;">PIIB1407E</p>	<p>Loosening nuts, screws and bolts</p>

PRECAUTIONS

< PRECAUTION >

- To reinstall the rubber hose securely, make sure that hose insertion length and orientation is correct. (If tube is equipped with hose stopper, insert rubber hose into tube until it butts up against hose stopper.)

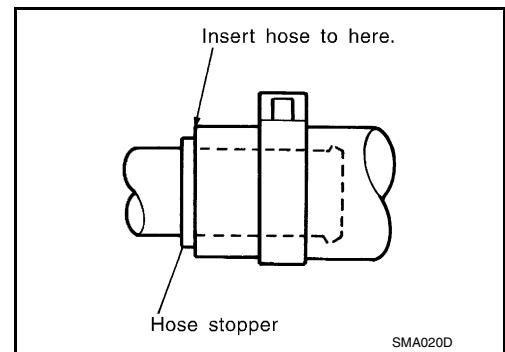

HOSE CLAMPING

- If old rubber hose is re-used, install hose clamp in its original position (at the indentation where the old clamp was). If there is a trace of tube bulging left on the old rubber hose, align rubber hose at that position.
- Discard old clamps; replace with new ones.

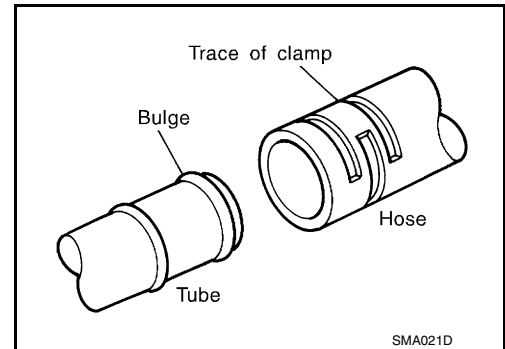

- After installing plate clamps, apply force to them in the direction of the arrow, tightening rubber hose equally all around.

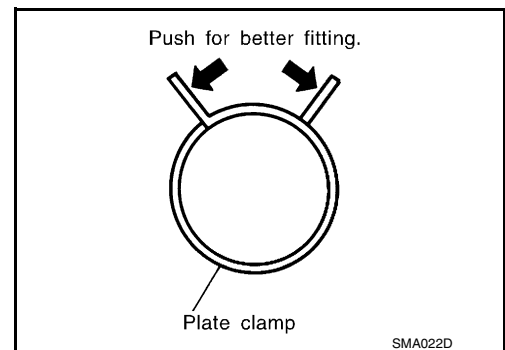

Engine Oils

INFOID:0000000012568999

Prolonged and repeated contact with used engine oil may cause skin cancer. Try to avoid direct skin contact with used oil.

If skin contact is made, wash thoroughly with soap or hand cleaner as soon as possible.

HEALTH PROTECTION PRECAUTIONS

- Avoid prolonged and repeated contact with oils, particularly used engine oils.
- Wear protective clothing, including impervious gloves where practicable.
- Do not put oily rags in pockets.
- Avoid contaminating clothes, particularly underpants, with oil.
- Heavily soiled clothing and oil-impregnated footwear should not be worn. Overalls must be cleaned regularly.
- First aid treatment should be obtained immediately for open cuts and wounds.
- Use barrier creams, applying them before each work period, to help the removal of oil from the skin.
- Wash with soap and water to ensure all oil is removed (skin cleansers and nail brushes will help). Preparations containing lanolin replace the natural skin oils which have been removed.
- Do not use gasoline, kerosene, diesel fuel, gas oil, thinners or solvents for cleaning skin.
- If skin disorders develop, obtain medical advice without delay.
- Where practical, degrease components prior to handling.
- Where there is a risk of eye contact, eye protection should be worn, for example, chemical goggles or face shields; in addition an eye wash facility should be provided.

PREPARATION

< PREPARATION >

PREPARATION

PREPARATION

Special Service Tool

INFOID:000000012564952

The actual shape of the tools may differ from those illustrated here.

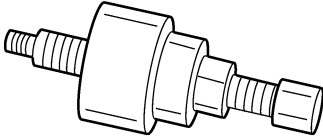
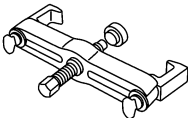
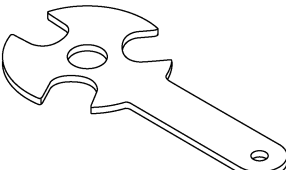
Tool number (TechMate No.) Tool name	Description
<p>— (J-41425-NIS) AL Tubing Repair Kit</p>	<p>Repairing leaks in A/C tubes</p> <div style="text-align: center;">  <p style="font-size: small;">ALIIA0390ZZ</p> </div>
<p>— (J-38873-A) Drive plate installer</p>	<p>Installing pulley</p> <div style="text-align: center;">  <p style="font-size: small;">WJIA0367E</p> </div>
<p>KV99233130 (J-29884) Pulley puller</p>	<p>Removing pulley</p> <div style="text-align: center;">  <p style="font-size: small;">LHA172</p> </div>
<p>— (J-44614) A/C Comp Clutch Wrench</p>	<p>Clutch disc holding tool</p> <div style="text-align: center;">  <p style="font-size: small;">ALIIA0971ZZ</p> </div>

HFC-134a (R-134a) Service Tool and Equipment

INFOID:000000012564953

Do not mix HFC-134a (R-134a) refrigerant and/or the specified oil with CFC-12 (R-12) refrigerant and/or the oil.

Separate and non-interchangeable service equipment must be used for handling each type of refrigerant/oil. Refrigerant container fittings, service hose fittings and service equipment fittings (equipment which handles refrigerant and/or oil) are different between CFC-12 (R-12) and HFC-134a (R-134a). This is to avoid mixed use of the refrigerants/oil.

Adapters that convert one size fitting to another must not be used refrigerant/oil contamination will occur and compressor malfunction will result.

AIR MIX DOOR MOTOR

[AUTOMATIC AIR CONDITIONER]

< DTC/CIRCUIT DIAGNOSIS >

2. Using CONSULT, check "DVR MIX FDBCK" in "DATA MONITOR" mode in "HVAC". Refer to [HAC-17, "CONSULT Function \(HVAC\)"](#).
3. Observe "DVR MIX FDBACK" voltage while rotating temperature control dial (driver) between 32°C (90°F) and 18°C (60°F).

Monitor Item	Condition	Results
DVR MIX FDBCK	Rotate temperature control dial (driver) between 32°C (90°F) and 18°C (60°F)	Voltage varies with dial rotation between 0.2 and 4.8 volts.

Is the inspection result normal?

- YES >> • Air mix door motor (driver) is OK.
 • Inspect air mix door (driver) for mechanical failure and repair if necessary. If air mix door (driver) is OK, refer to [HAC-73, "Component Function Check"](#) for insufficient cooling or [HAC-81, "Component Function Check"](#) for insufficient heating.

NO >> GO TO 2.

2. CHECK AIR MIX DOOR MOTOR (DRIVER) CIRCUITS FOR OPEN AND SHORT TO GROUND

1. Turn ignition switch OFF.
2. Disconnect the front air control harness connector M52 and the air mix door motor (driver) harness connector M148.
3. Check continuity between front air control harness connector M52 terminals 17, 18 and the air mix door motor (driver) harness connector M148 terminals 6, 5.

Connector	Terminal	Connector	Terminal	Continuity
M52	17	M148	6	Yes
	18		5	

4. Check continuity between front air control harness connector M52 terminals 17, 18 and ground.

Connector	Terminal	—	Continuity
M52	17	Ground	No
	18		

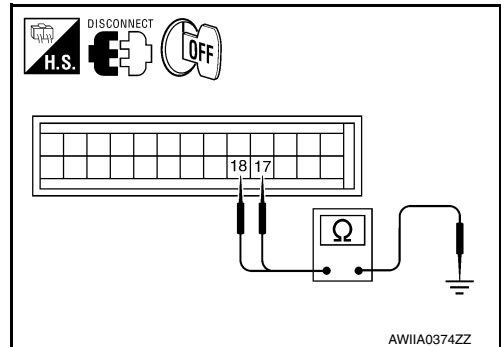

Is the inspection result normal?

- YES >> GO TO 3.
 NO >> Repair or replace harness as necessary.

3. CHECK FRONT AIR CONTROL FOR AIR MIX DOOR MOTOR (DRIVER) POWER AND GROUND

1. Reconnect front air control harness connector.
2. Turn ignition switch ON.
3. Rotate temperature control dial (driver) to 32°C (90°F).
4. Check voltage between front air control harness connector M52 terminal 17 and terminal 18 while rotating temperature control dial (driver) to 18°C (60°F) and back to 32°C (90°F).

Connector	Terminals		Condition	Voltage (Approx.)
	(+)	(-)		
M52	17	18	While rotating temperature control dial (driver) from 32°C (90°F) to 18°C (60°F)	Battery voltage
	18	17	While rotating temperature control dial (driver) from 18°C (60°F) to 32°C (90°F)	Battery voltage

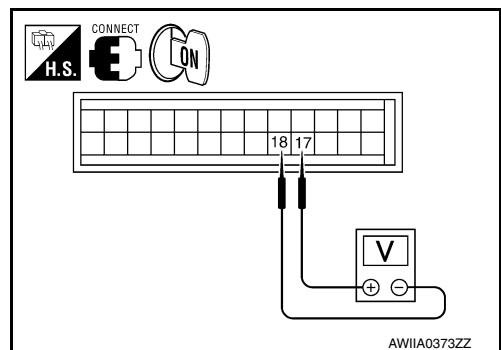

Is the inspection result normal?

- YES >> GO TO 4.
 NO >> Replace front air control. Refer to [VTL-7, "Removal and Installation"](#).

INSUFFICIENT HEATING

[AUTOMATIC AIR CONDITIONER]

< SYMPTOM DIAGNOSIS >

Check engine coolant temperature sensor. Refer to [EC-671, "Component Inspection"](#).

Is the inspection result normal?

YES >> System OK.

NO >> Repair or replace as necessary. Retest.

9.CHECK HEATER HOSES

Check heater hoses for proper installation.

Is the inspection result normal?

YES >> System OK.

NO >> 1. Back flush heater core.

2. Drain the water from the system.

3. Refill system with new engine coolant. Refer to [CO-40, "Changing Engine Coolant"](#).

4. GO TO 10 to retest.

10.CHECK HEATER HOSE TEMPERATURES

1. Start engine and warm it up to normal operating temperature.

2. Touch both the inlet and outlet heater hoses. The inlet hose should be hot and the outlet hose should be warm.

Is the inspection result normal?

YES >> System OK.

NO >> Replace heater core. Refer to [VTL-19, "Removal and Installation"](#).

AIR CONDITIONER CONTROL

< WIRING DIAGRAM >

[MANUAL A/C (TYPE 1)]

Connector No.	E5
Connector Name	WIRE TO WIRE
Connector Color	WHITE

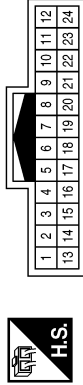

Terminal No.	Color of Wire	Signal Name
2	L	-
3	P	-
15	BR	-
16	B	-(FOR MEXICO)
16	LG	-(EXCEPT FOR MEXICO)
17	P	-

Connector No.	E2
Connector Name	WIRE TO WIRE
Connector Color	WHITE

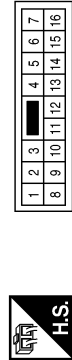

Terminal No.	Color of Wire	Signal Name
2	L	-
3	P	-
8	Y	-

Connector No.	M167
Connector Name	JOINT CONNECTOR-M02
Connector Color	BLUE

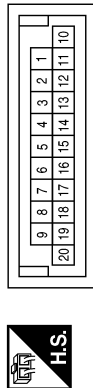

Terminal No.	Color of Wire	Signal Name
1	P	-
2	P	-
7	P	-
10	L	-
11	L	-
16	L	-

Connector No.	E26
Connector Name	WIRE TO WIRE
Connector Color	WHITE

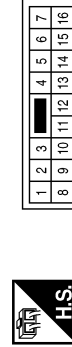

Terminal No.	Color of Wire	Signal Name
10	P	-
11	L	-

Connector No.	E16
Connector Name	ECM (WITH QR25DE)
Connector Color	BLACK

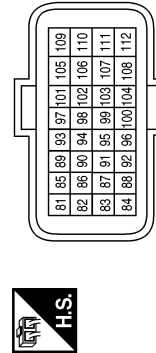

Terminal No.	Color of Wire	Signal Name
97	P	CAN-L
98	L	CAN-H

Connector No.	E8
Connector Name	ECM (WITH VQ40DE FOR MEXICO)
Connector Color	BLACK

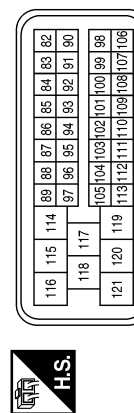

Terminal No.	Color of Wire	Signal Name
86	P	CAN-L
94	L	CAN-H

ABIIA1248GB

A
B
C
D
E
F
G
H
HAC
J
K
L
M
N
O
P

INTAKE SENSOR

System Description

INFOID:000000012565118

COMPONENT DESCRIPTION

Intake Sensor

The intake sensor is located on top of the heater and cooling unit assembly next to the A/C evaporator cover. It converts temperature of air after it passes through the evaporator into a resistance value which is then input to the front air control.

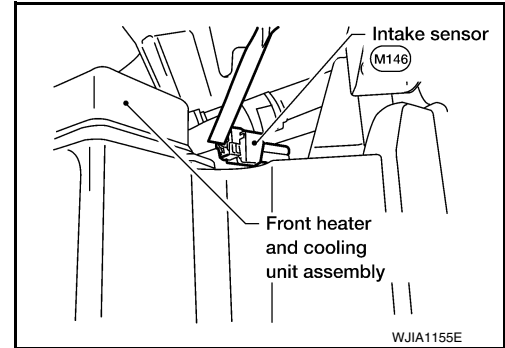

Intake Sensor Diagnosis Procedure

INFOID:000000012565119

Regarding Wiring Diagram information, refer to [HAC-200. "Wiring Diagram - With Type 2"](#).

DIAGNOSTIC PROCEDURE FOR INTAKE SENSOR

SYMPTOM: Intake sensor circuit is open or shorted.

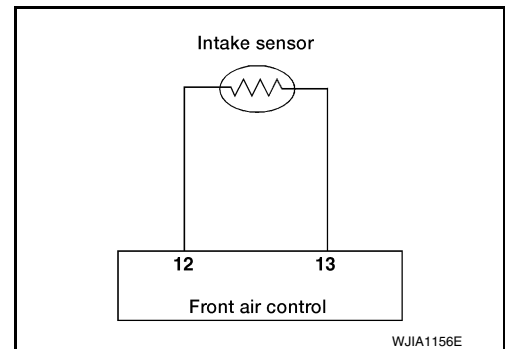

1. CHECK VOLTAGE BETWEEN INTAKE SENSOR AND GROUND

1. Disconnect intake sensor connector.
2. Turn ignition switch ON.
3. Check voltage between intake sensor harness connector M146 terminal 2 and ground.

2 - Ground : **Approx. 5V**

Is the inspection result normal?

- YES >> GO TO 2.
NO >> GO TO 4.

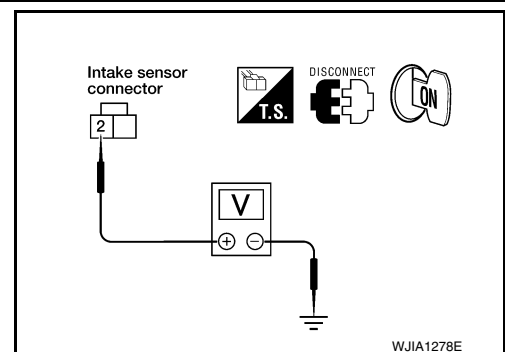

2. CHECK CIRCUIT CONTINUITY BETWEEN INTAKE SENSOR AND FRONT AIR CONTROL

SECTION **INL**

INTERIOR LIGHTING SYSTEM

A
B
C
D
E
F
G
H
I
J
K
L
M
N
O
P

CONTENTS

WITH POWER DOOR LOCKS	
BASIC INSPECTION	3
DIAGNOSIS AND REPAIR WORKFLOW	3
Work Flow	3
SYSTEM DESCRIPTION	6
INTERIOR ROOM LAMP CONTROL SYSTEM	
.....	6
System Diagram	6
System Description	6
Component Parts Location	7
Component Description	8
ILLUMINATION CONTROL SYSTEM	9
System Diagram	9
System Description	9
Component Parts Location	10
Component Description	10
DIAGNOSIS SYSTEM (BCM)	11
COMMON ITEM	11
COMMON ITEM : CONSULT Function (BCM - COMMON ITEM)	11
INT LAMP	11
INT LAMP : CONSULT Function (BCM - INT LAMP)	12
BATTERY SAVER	12
BATTERY SAVER : CONSULT Function (BCM - BATTERY SAVER)	12
DTC/CIRCUIT DIAGNOSIS	14
POWER SUPPLY AND GROUND CIRCUIT	14
BCM	14
BCM : Diagnosis Procedure	14
BATTERY SAVER OUTPUT/POWER SUPPLY CIRCUIT	16
Description	16
Component Function Check	16
Diagnosis Procedure	16
INTERIOR ROOM LAMP CONTROL CIRCUIT	
.....	18
Description	18
Component Function Check	18
Diagnosis Procedure	18
CARGO LAMP CONTROL CIRCUIT	20
Description	20
Diagnosis Procedure	20
Component Inspection	22
IGNITION KEYHOLE ILLUMINATION CONTROL CIRCUIT	24
Description	24
Component Function Check	24
Diagnosis Procedure	24
ECU DIAGNOSIS INFORMATION	26
BCM (BODY CONTROL MODULE)	26
Reference Value	26
Terminal Layout	29
Physical Values	29
Fail Safe	34
DTC Inspection Priority Chart	34
DTC Index	35
WIRING DIAGRAM	37
INTERIOR ROOM LAMP	37
Wiring Diagram - With Power Door Lock System	37
ILLUMINATION	50
Wiring Diagram	50
SYMPTOM DIAGNOSIS	60

INL

ILLUMINATION

< WIRING DIAGRAM >

[WITH POWER DOOR LOCKS]

Connector No.	M97
Connector Name	AV CONTROL UNIT (WITH NAVI WITH AMPLIFIER)
Connector Color	WHITE

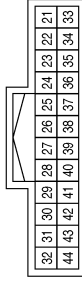

Terminal No.	Color of Wire	Signal Name
23	P	MR OUTPUT
44	GR	ILL CONT

Connector No.	M96
Connector Name	AV CONTROL UNIT (WITH NAVI WITH AMPLIFIER)
Connector Color	WHITE

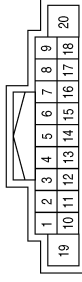

Terminal No.	Color of Wire	Signal Name
9	R	LIGHT SW

Connector No.	M94
Connector Name	SONAR SYSTEM OFF SWITCH
Connector Color	GRAY

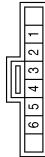

Terminal No.	Color of Wire	Signal Name
3	R	-
4	BR	-

Connector No.	M108
Connector Name	AV CONTROL UNIT (WITH NAVI WITHOUT AMPLIFIER)
Connector Color	WHITE

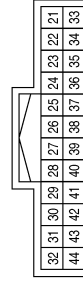

Terminal No.	Color of Wire	Signal Name
23	P	MR OUTPUT
44	GR	ILL CONT

Connector No.	M107
Connector Name	AV CONTROL UNIT (WITH NAVI WITHOUT AMPLIFIER)
Connector Color	WHITE

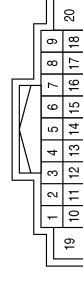

Terminal No.	Color of Wire	Signal Name
9	R	LIGHT SW

Connector No.	M102
Connector Name	COMBINATION SWITCH (SPIRAL CABLE)
Connector Color	GRAY



Terminal No.	Color of Wire	Signal Name
20	W	-
21	R	-

ABLIA6828GB

ILLUMINATION

< WIRING DIAGRAM >

[WITHOUT POWER DOOR LOCKS]

Connector No.	M154
Connector Name	VDC OFF SWITCH
Connector Color	GRAY

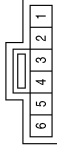

Terminal No.	Color of Wire	Signal Name
3	R	-
4	BR	-

Connector No.	M149
Connector Name	DIFFERENTIAL LOCK MODE SWITCH
Connector Color	WHITE



Terminal No.	Color of Wire	Signal Name
4	R	-
5	BR	-

Connector No.	M141
Connector Name	4WD SHIFT SWITCH
Connector Color	GRAY



Terminal No.	Color of Wire	Signal Name
7	R	-
8	BR	-

Connector No.	M159
Connector Name	DOOR MIRROR REMOTE CONTROL SWITCH
Connector Color	WHITE

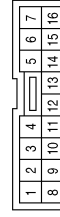

Terminal No.	Color of Wire	Signal Name
15	BR	-
16	R	-

Connector No.	M156
Connector Name	A/T SHIFT SELECTOR
Connector Color	WHITE



Terminal No.	Color of Wire	Signal Name
3	R	-
5	BR	-

Connector No.	M155
Connector Name	HILL DESCENT CONTROL SWITCH
Connector Color	WHITE



Terminal No.	Color of Wire	Signal Name
5	R	-
6	BR	-

ABLIA6829GB

A
B
C
D
E
F
G
H
I
J
K
INL
M
N
O
P

CLUSTER LID C

< REMOVAL AND INSTALLATION >

CLUSTER LID C

Removal and Installation

INFOID:000000012564885

TYPE 1

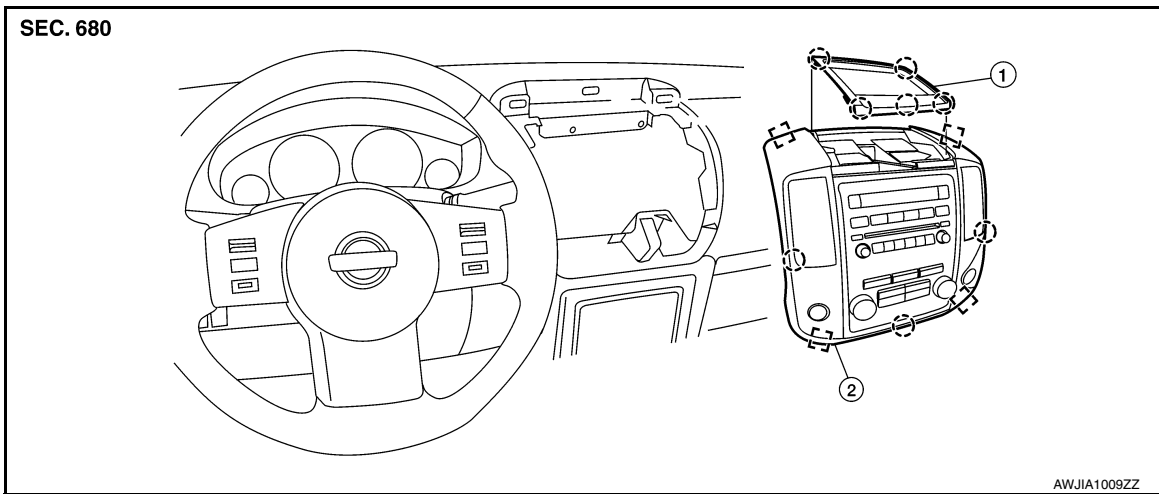

1. Storage tray

2. Cluster lid C

 Pawl

 Metal clip

Removal

1. Release the storage tray pawls using a suitable tool and remove.
2. Remove the cluster lid C screws (A).

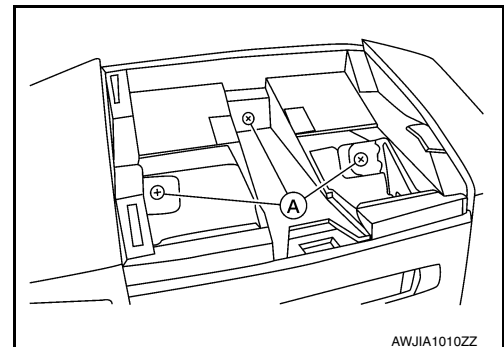

3. Release the cluster lid C metal clips and pawls using a suitable tool and remove.
4. Disconnect harness connectors from cluster lid C and remove.
5. Remove the audio unit from cluster lid C, if necessary. Refer to [AV-51, "Removal and Installation"](#).
6. Remove the front air control from cluster lid C, if necessary. Refer to [VTL-7, "Removal and Installation"](#).
7. Remove the hazard switch from cluster lid C, if necessary. Refer to [EXL-147, "Removal and Installation"](#).
8. Remove the passenger air bag indicator lamp from cluster lid C, if necessary. Refer to [SR-15, "Removal and Installation"](#).

Installation

Installation is in the reverse order of removal.

DIAGNOSIS AND REPAIR WORKFLOW

< BASIC INSPECTION >

[CAN]

Diagnosis Sheet (CAN Type 5)

INFOID:000000012563475

< Checklist >

Item	Item	Check box
1	ECM [▲]	<input type="checkbox"/>
2	TCM	<input type="checkbox"/>
3	HVAC [▲]	<input type="checkbox"/>
4	A-BAG [▲]	<input type="checkbox"/>
5	BCM [▲]	<input type="checkbox"/>
6	M&A [▲]	<input type="checkbox"/>
7	ABS	<input type="checkbox"/>
8	IPDM-E [▲]	<input type="checkbox"/>

Possible root cause

Inspection result

▲ : Diag on CAN unit

JSMIA1333GB

PERIODIC MAINTENANCE

ENGINE OIL

Inspection

INFOID:0000000012567497

LU

OIL LEVEL

- Before starting the engine make sure the vehicle is parked on a flat and level surface, then check the oil level. If the engine is already running, turn it off and allow 10 minutes before checking.
- Pull out oil level gauge and wipe clean.
- Insert oil level gauge.
- Check that the oil level is within the low (L) and high (H) range as indicated on the dipstick.
- If the engine oil level is out of range, add oil as necessary. Refer to [MA-18, "FOR USA AND CANADA : Fluids and Lubricants"](#).

CAUTION:

Do not overfill the engine with oil.

NOTE:

It is normal to add some oil between oil maintenance intervals or during the break-in period, depending on the severity of the operating conditions.

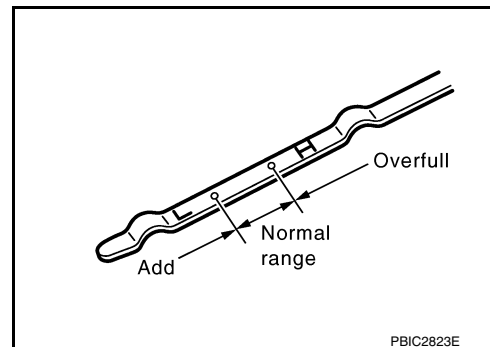

PBIC2623E

OIL APPEARANCE

- Check the engine oil for a white milky appearance or excessive contamination.
- If the engine oil is milky, it is highly probable that it is contaminated with engine coolant. Repair or replace damaged parts.

OIL LEAKAGE

Check for engine oil leakage around the following area.

- Oil pan
- Oil pan drain plug
- Oil pressure switch
- Oil filter
- Oil cooler
- Intake valve timing control cover and intake valve timing control solenoid valve
- Front cover
- Mating surface between cylinder block and lower cylinder block
- Mating surface between cylinder block and cylinder head
- Mating surface between cylinder head and rocker cover
- Crankshaft oil seals (front and rear)

OIL PRESSURE CHECK

WARNING:

- **Be careful not to burn yourself, as the engine and engine oil may be hot.**
- **Put the A/T shift selector in the Park (P) position (A/T models) or Neutral position (M/T models), and apply parking brake securely.**

1. Check engine oil level. Refer to [LU-9, "Inspection"](#).
2. Disconnect the harness connector from oil pressure switch.
3. Remove oil pressure switch using a suitable tool. Refer to [EM-81, "Exploded View"](#).

CAUTION:

Do not drop or shock oil pressure switch.

ENGINE MAINTENANCE (QR25DE ENGINE)

< PERIODIC MAINTENANCE >

3. Screw on the oil filter manually until it touches the installation surface, then tighten it by 2/3 turn as shown. Or tighten to specification.

Oil filter : 17.7 N·m (1.8 kg·m, 13 ft·lb)

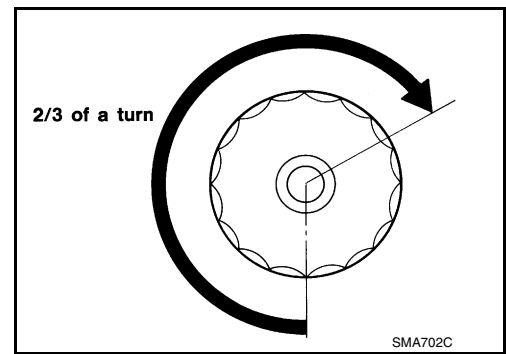

4. Refill the engine with new engine oil. Refer to [LU-10, "Changing Engine Oil"](#).
5. Inspect the engine for oil leaks. Refer to [LU-9, "Inspection"](#).

INSPECTION AFTER INSTALLATION

1. Check the engine oil level. Refer to [LU-9, "Inspection"](#).
2. Start the engine and check for engine oil leaks.
3. Stop the engine and wait for 10 minutes.
4. Check the engine oil level and add engine oil as required.

SPARK PLUG

SPARK PLUG : Exploded View

INFOID:000000012562896

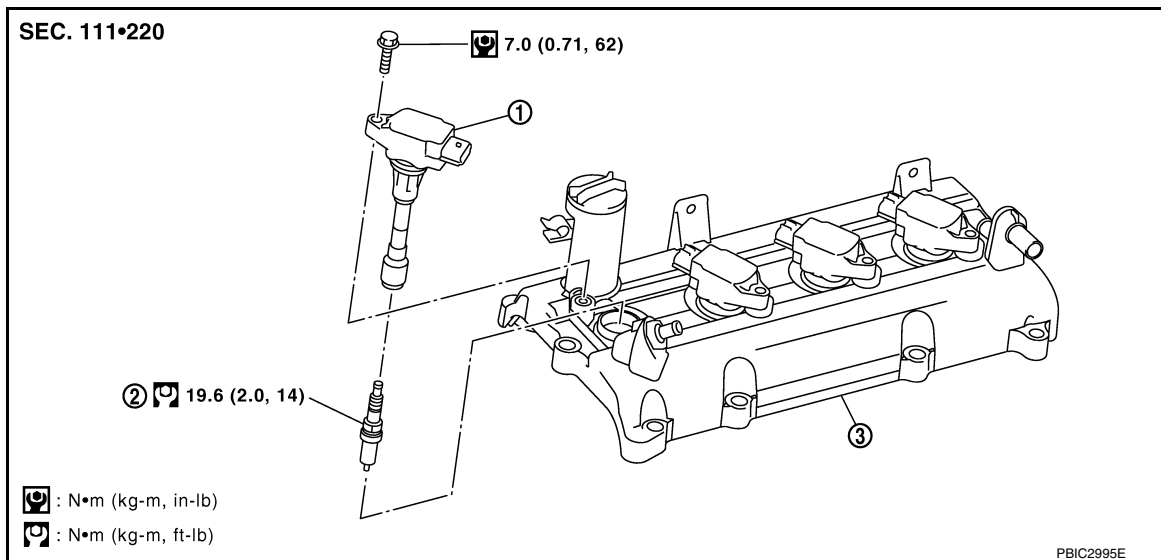

1. Ignition coil
2. Spark plug
3. Rocker cover

SPARK PLUG : Removal and Installation

INFOID:000000012562897

WARNING:

Be sure the engine and ignition switch are off and that the parking brake is engaged securely.

CAUTION:

Be sure to use the correct socket to remove the spark plugs. An incorrect socket can damage the spark plugs.

REMOVAL

1. Remove the ignition coil. Refer to [EM-37, "Removal and Installation"](#).

INSIDE MIRROR

< UNIT REMOVAL AND INSTALLATION >

UNIT REMOVAL AND INSTALLATION

INSIDE MIRROR

Inside Mirror Assembly

INFOID:000000012563601

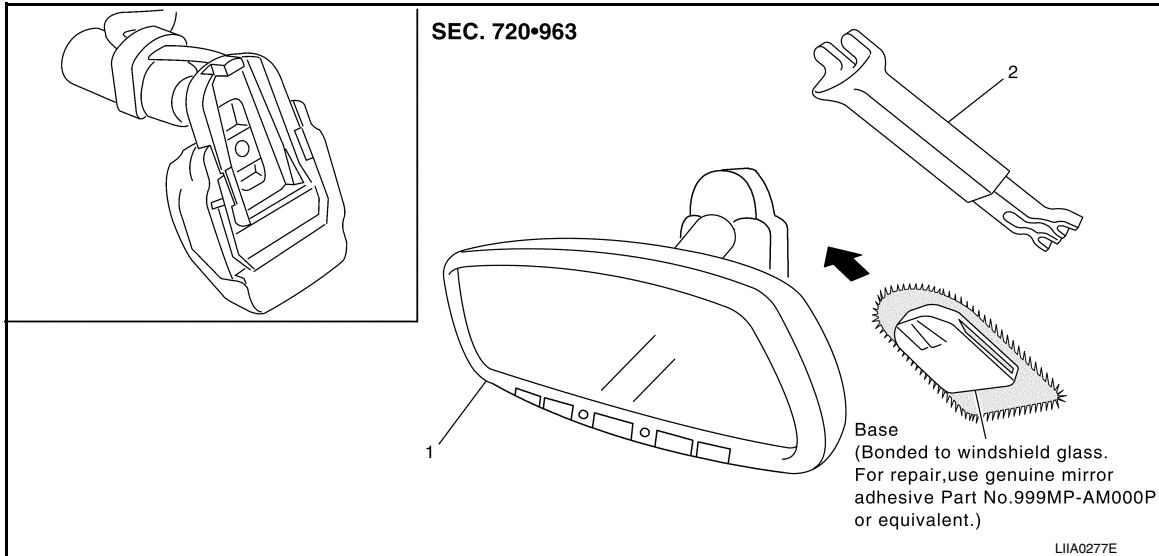

1. Inside mirror

2. Inside mirror finisher (If equipped)

REMOVAL

1. Remove the mirror finisher (if equipped).
2. Remove the screw and slide the mirror upward to remove.
3. Disconnect the connector (if equipped).
4. Remove the inside mirror.

INSTALLATION

Installation is in the reverse order of removal.

A

B

C

D

E

F

G

H

I

J

K

MIR

M

N

O

P

BCM (BODY CONTROL MODULE)

< ECU DIAGNOSIS INFORMATION >

CONSULT display	Fail-safe	Low tire pressure warning lamp ON	Reference page
C1716: [PRESSDATA ERR] FL	—	X	WT-19
C1717: [PRESSDATA ERR] FR	—	X	WT-19
C1718: [PRESSDATA ERR] RR	—	X	WT-19
C1719: [PRESSDATA ERR] RL	—	X	WT-19
C1720: [CODE ERR] FL	—	X	WT-17
C1721: [CODE ERR] FR	—	X	WT-17
C1722: [CODE ERR] RR	—	X	WT-17
C1723: [CODE ERR] RL	—	X	WT-17
C1724: [BATT VOLT LOW] FL	—	X	WT-17
C1725: [BATT VOLT LOW] FR	—	X	WT-17
C1726: [BATT VOLT LOW] RR	—	X	WT-17
C1727: [BATT VOLT LOW] RL	—	X	WT-17
C1729: VHCL SPEED SIG ERR	—	X	WT-21
C1735: IGNITION SIGNAL	—	X	WT-22

SIGNAL BUFFER SYSTEM

< SYSTEM DESCRIPTION >

[IPDM E/R]

SIGNAL BUFFER SYSTEM

System Diagram

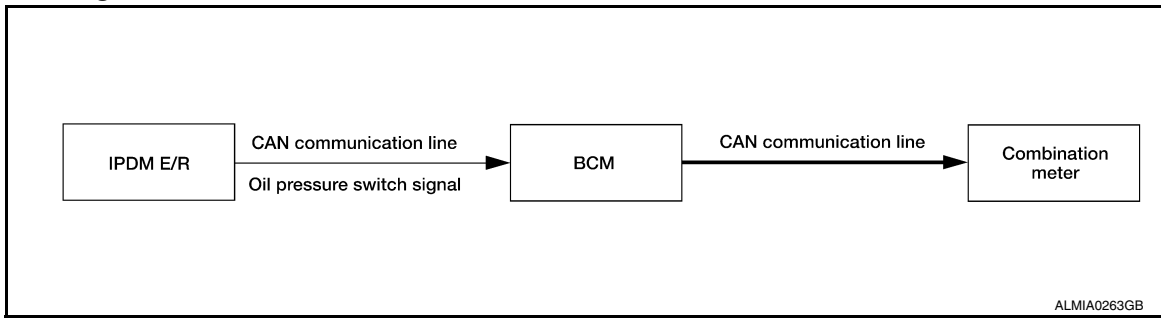

System Description

INFOID:000000012797944

OUTLINE

BCM has the signal transmission function that outputs/transmits each input/received signal to each unit.

Signal transmission function list

Signal name	Input	Output	Description
Oil pressure switch signal	IPDM E/R (CAN)	Combination meter (CAN)	Transmits the received oil pressure switch signal via CAN communication.

GROUND

< WIRING DIAGRAM >

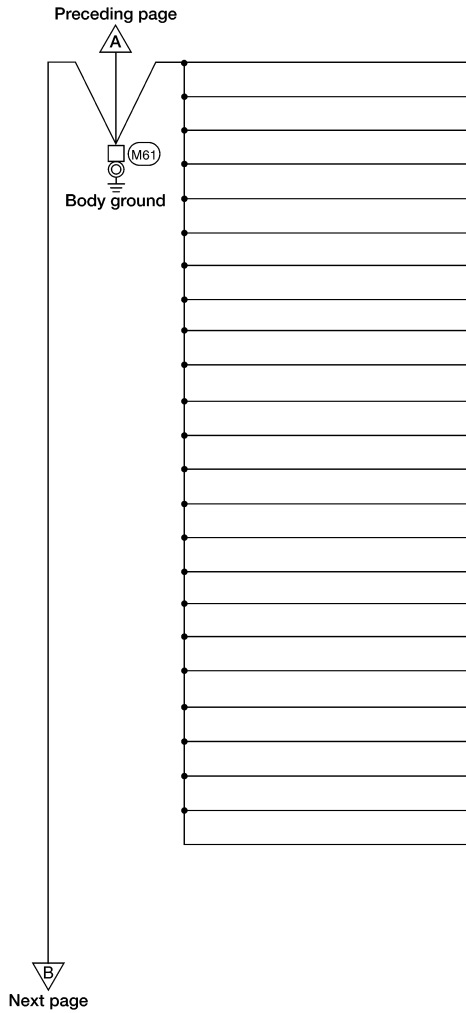
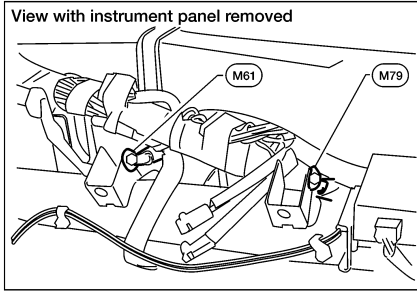

CONNECTOR NUMBER	CONNECT TO
(M13)	Front passenger air bag OFF indicator
(M24)	Combination meter (Terminal No. 13)
(M34)	In-vehicle sensor
(M35)	Air bag diagnosis sensor unit (Terminal No. 2)
(M47)	Steering angle sensor
(M49)	Front air control (Terminal No. 20) (manual with type 2)
(M51)	Front blower switch
(M55)	Hazard switch
(M56)	Front air control (Terminal No. 35) (with auto A/C)
(M59)	Front air control (Terminal No. 35) (manual with type 1)
(M71)	Cargo lamp switch
(M121)	Variable blower control (front)
(M152)	Transfer control unit (Terminal No. 6)
(M152)	Transfer control unit (Terminal No. 18)
(M153)	Transfer control unit (Terminal No. 32)
(M154)	VDC OFF switch
(M155)	Hill descent control switch
(M156)	A/T shift selector (Terminal No. 2)
(M156)	A/T shift selector (Terminal No. 8)
(M156)	A/T shift selector (Terminal No. 10)
(M159)	Door mirror remote control switch
(M160)	Front heated seat switch RH
(M161)	Front heated seat switch LH
(M163)	Clutch interlock cancel switch

A
B
C
D
E
F
G
H
I
J
K
L

PG

N
O
P

ABMIA5552GB

FUSIBLE LINK INSPECTION

< BASIC INSPECTION >

FUSIBLE LINK INSPECTION

Fusible Link

INFOID:000000012563584

A melted fusible link can be detected either by visual inspection or by feeling with finger tip. If its condition is questionable, use circuit tester or test lamp.

1 : Fusible link

←: Vehicle front

CAUTION:

- If fusible link should melt, it is possible that critical circuit (power supply or large current carrying circuit) is shorted. In such a case, carefully check and eliminate cause of malfunction.
- Never wrap outside of fusible link with vinyl tape. Important: Never let fusible link touch any other wiring harness, vinyl or rubber parts.

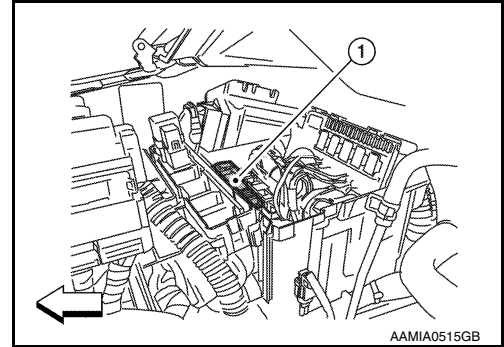

AAMIA0515GB

POWER WINDOW SYSTEM

< WIRING DIAGRAM >

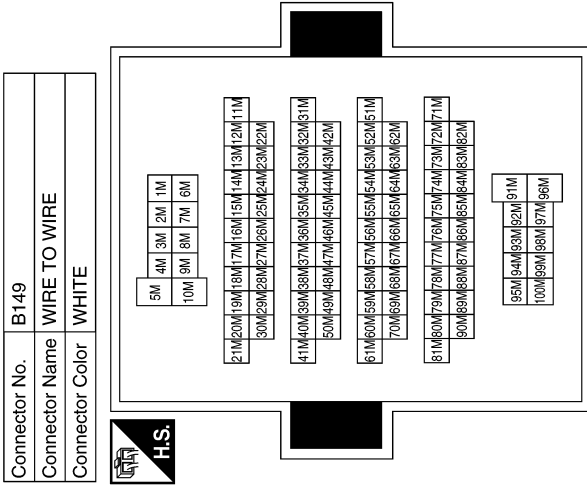

Terminal No.	Color of Wire	Signal Name
49M	LG	-

Connector No. D9
Connector Name FRONT POWER WINDOW MOTOR LH
Connector Color BROWN



Terminal No.	Color of Wire	Signal Name
1	G/W	-
2	G/R	-

Connector No. B107
Connector Name WIRE TO WIRE
Connector Color WHITE

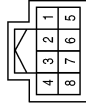

Terminal No.	Color of Wire	Signal Name
7	B	-
8	LG	-

Connector No. D7
Connector Name MAIN POWER WINDOW AND DOOR LOCK/UNLOCK SWITCH
Connector Color WHITE

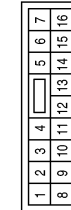

Terminal No.	Color of Wire	Signal Name
2	G/Y	-
3	L/W	-
5	W/R	-
6	G/R	-
7	G/W	-
14	B	-

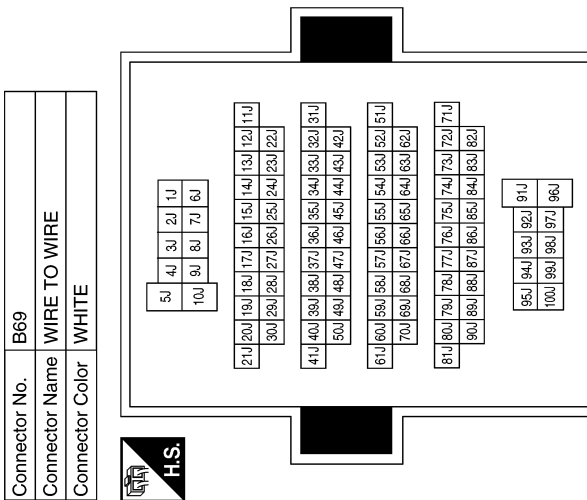

Terminal No.	Color of Wire	Signal Name
41J	GR	-

Connector No. D2
Connector Name WIRE TO WIRE
Connector Color BROWN



Terminal No.	Color of Wire	Signal Name
1	G/Y	-
6	L/W	-
9	B	-
10	W/R	-

ABKIA5195GB

AXLE OIL SEAL

< SERVICE INFORMATION >

[M226]

AXLE OIL SEAL

Removal and Installation

INFOID:000000012566391

The axle oil seal must be replaced every time the axle shaft is removed and installed. Refer to [RAX-19](#), "[Removal and Installation](#)".

CAUTION:

Do not reuse the axle oil seal.

SUNROOF SYSTEM

< REMOVAL AND INSTALLATION >

2. Install the glass lid screws. (First tighten left front bolt, then tighten right rear bolt on glass lid to prevent lid from moving while tightening other bolts.)
3. Adjust the glass lid if necessary. Refer to [RF-51. "Adjustment"](#).

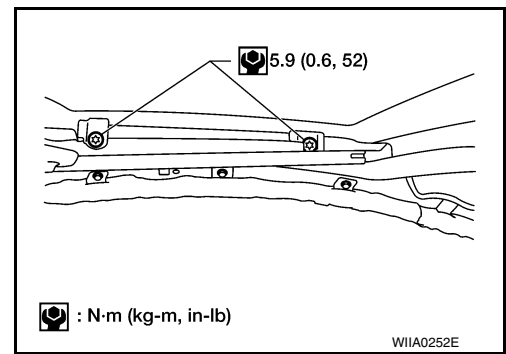

SUNROOF LID SEAL

Removal

1. Remove glass lid assembly. Refer to GLASS LID ASSEMBLY REMOVAL AND INSTALLATION procedure in this section.
2. Inspect rubber edge of glass lid.
NOTE:
If rubber edge is deformed or damaged, entire glass lid must be replaced.
3. Remove sunroof lid seal from the rubber edge of glass lid by pulling it outward.

Installation

1. Inspect and clean the ditch groove of the rubber edge removing any dirt or debris.
2. Stretch sunroof lid seal around glass lid and push the tongue edge into the ditch groove.
NOTE:
If needed, very light taps with a rubber hammer can be used to press the seal into place.
3. Install glass lid into sunroof unit. Refer to GLASS LID REMOVAL AND INSTALLATION procedure in this section.

WIND DEFLECTOR

Removal

1. Open the sunroof.
2. Remove screws from the left, center, and right side wind deflector holders.
3. Remove the wind deflector from the sunroof unit.

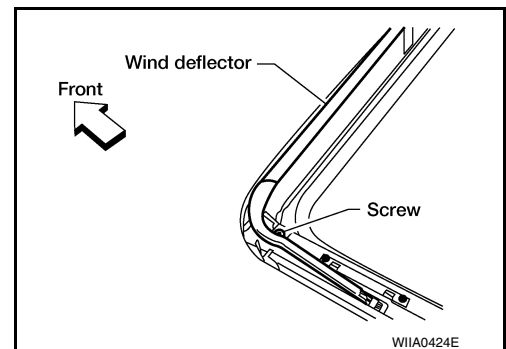

Installation

Installation is in the reverse order of removal.











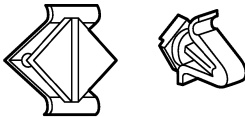

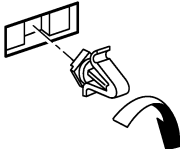
SUNSHADE ASSEMBLY

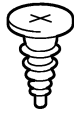
Removal

1. Remove the sunroof unit. Refer to SUNROOF UNIT REMOVAL AND INSTALLATION procedure in this section.

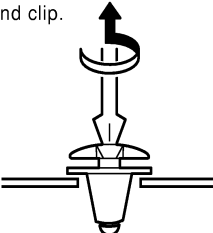
CLIP LIST

< PREPARATION >

Symbol No.	Shapes	Removal & Installation	
CG101 		Removal:  Rotate 45° to remove	Installation: 
CS102 			
CS113 		Removal: Disconnect upper connection of clip with a flat-bladed screwdriver, then remove clip while inserting a flat-bladed screwdriver between body panel and clip. 	
C111 			

SIIA0317E

A
B
C
D
E
F
G
H
I
SE
K
L
M
N
O
P

KEY CYLINDER SWITCH

< DTC/CIRCUIT DIAGNOSIS >

M18	7	Ground	Neutral/Lock	1.5
			Unlock	0
	8		Neutral/Unlock	1.5
			Lock	0

Is the inspection result normal?

- YES >> Front door lock assembly LH (key cylinder switch) signal is OK.
 NO >> GO TO 2.

2. CHECK FRONT DOOR LOCK ASSEMBLY LH (KEY CYLINDER SWITCH)

- Turn ignition switch OFF.
- Disconnect front door lock assembly LH (key cylinder switch).
- Check continuity between front door lock assembly LH (key cylinder switch) connector D14 terminals 3, 4 and 5.

Terminals	Condition	Continuity
4 - 5	Key is turned to LOCK.	Yes
	Key is in N position or turned to UNLOCK	No
3 - 4	Key is turned to UNLOCK.	Yes
	Key is in N position or turned to LOCK	No

Is the inspection result normal?

- YES >> GO TO 3.
 NO >> Replace front door lock assembly LH (key cylinder switch). Refer to [DLK-137. "Removal and Installation"](#).

3. CHECK FRONT DOOR LOCK ASSEMBLY LH HARNESS

- Disconnect BCM.
- Check continuity between BCM connector M18 terminals 7, 8 and front door lock assembly LH connector D14 terminals 3, 5.

- 7 - 3** : Continuity should exist.
8 - 5 : Continuity should exist.

- Check continuity between BCM connector M18 terminals 7, 8 and ground.

- 7 - Ground** : Continuity should not exist.
8 - Ground : Continuity should not exist.

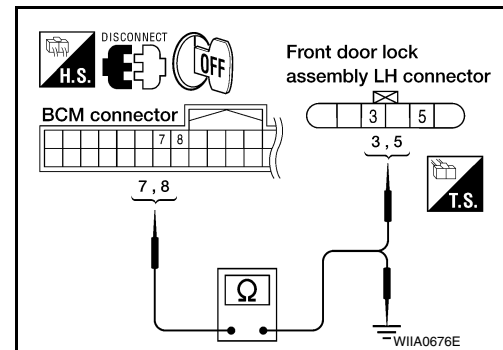

Is the inspection result normal?

- YES >> GO TO 4.
 NO >> Repair or replace harness.

4. CHECK FRONT DOOR LOCK ASSEMBLY LH GROUND

Check continuity between front door lock assembly LH connector D14 terminal 4 and ground.

- 4 - Ground** : Continuity should exist.

Is the inspection result normal?

- YES >> GO TO 5.
 NO >> Repair or replace harness.

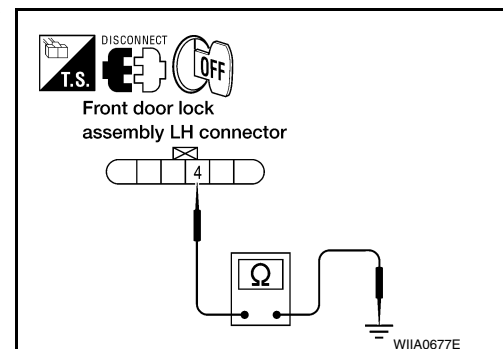

INSPECTION AND ADJUSTMENT

< BASIC INSPECTION >

INSPECTION AND ADJUSTMENT

Preliminary Check

INFOID:000000012563101

DESCRIPTION

The purpose of the sonar sensor preliminary check is to confirm that there are no outside factors affecting the sonar system.

CONDITIONS

- Ignition switch ON
- No obstructions within 3.0 m (10 ft.) of sonar sensors

SONAR SENSOR STATUS CHECK

- Check that the sonar sensors are properly aligned (no deformation in sensor mounting areas).
- Check that snow, mud or other foreign objects are not adhering to the sonar sensors.
- Check that there is no deformation, scratches or other damage to the sonar sensors.
- Check that water has not accumulated in the sonar sensors.

CAUTION:

Use water, cotton swab, or other soft material for cleaning the sensors.

1. Inspect for the following:
 - Physical damage to wiring
 - Physical damage to harness connectors
 - Loose or disconnected harness connectors
 - Physical damage to system components
2. Check that there are no obstacles within each sonar sensor's detection range.

Sonar sensors	Detection range
Rear	Approx. 1.8 m (5.9 ft.) maximum

3. Check that there are no nearby ultrasound sources such as the sounds of vehicle horns, motorcycle engines or truck air brakes.
4. Check that the vehicle is on a level surface.

SRS AIR BAG SYSTEM

< SYSTEM DESCRIPTION >

SYSTEM DESCRIPTION

SRS AIR BAG SYSTEM

SRS Configuration

INFOID:0000000012565189

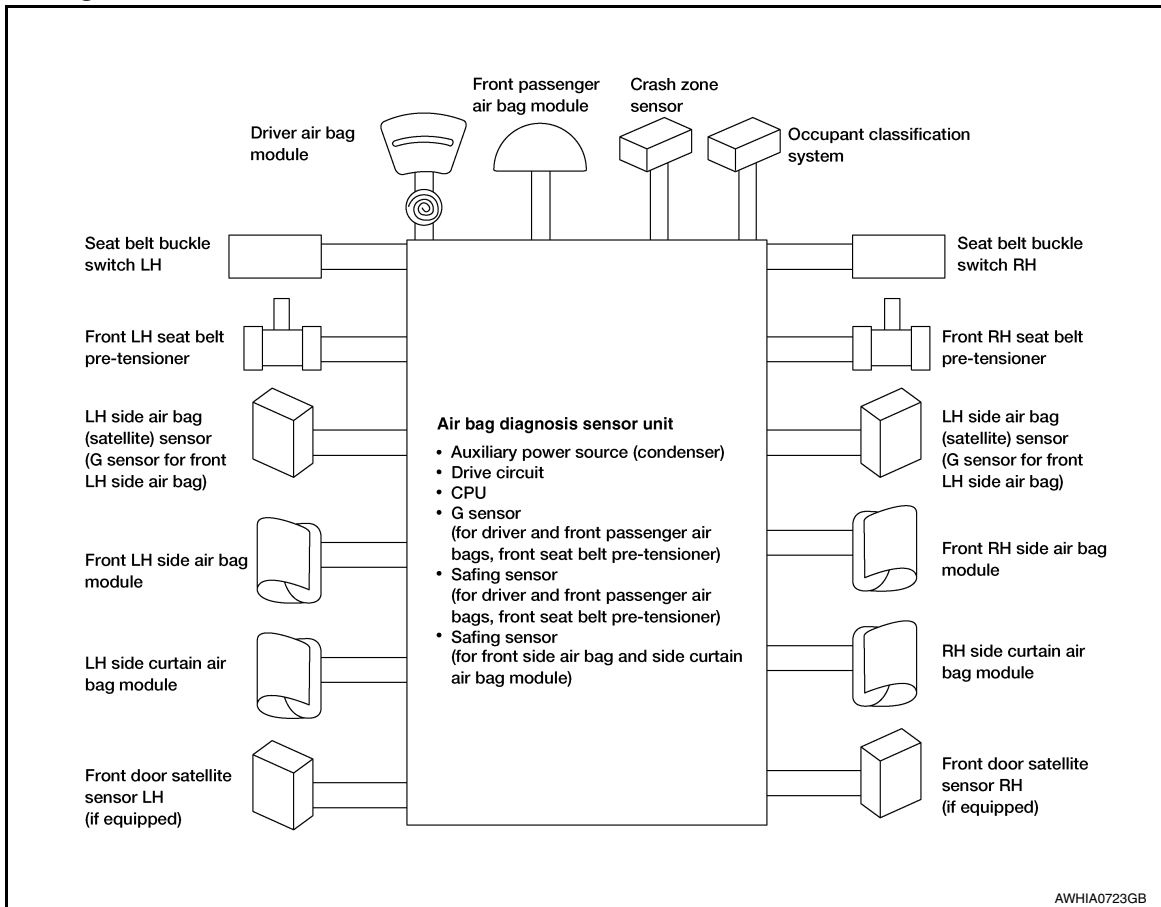

The air bag deploys if the air bag diagnosis sensor unit is activated while the ignition switch is in the ON or START position.

The collision modes for which supplemental restraint systems are activated are different among the SRS systems. For example, the driver air bag module, front passenger air bag module and front seat belt pre-tensioners are activated in a frontal collision but not in a side collision.

SRS configurations for some collision modes are as follows:

SRS configuration	Frontal collision	Left side collision	Right side collision	Rollover
Driver air bag module	X	—	—	—
Front passenger air bag module	X	—	—	—
Front LH seat belt pre-tensioner	X	—	—	X
Front RH seat belt pre-tensioner	X	—	—	X
Front LH side air bag module	—	X	—	—
Front RH side air bag module	—	—	X	—
LH side curtain air bag module	—	X	—	X
RH side curtain air bag module	—	—	X	X

B00D5 PASSENGER AIR BAG OFF INDICATOR

< DTC/CIRCUIT DIAGNOSIS >

1. CHECK SELF DIAGNOSTIC RESULT

1. Turn ignition switch ON.
2. Check the air bag warning lamp status. Refer to [SRC-15, "Self-Diagnosis Function \(Without CONSULT\)"](#).

NOTE:

SRS will not enter diagnosis mode if no malfunction is detected in user mode.

Is the DTC detected?

- YES >> Refer to [SRC-61, "Diagnosis Procedure"](#).
NO >> Inspection End.

Diagnosis Procedure

INFOID:000000012565241

1. HARNESS CONNECTOR

Visually inspect all applicable harness connectors for the following:

- Visible damage to connector or terminal
- Loose terminal
- Poor connection

NOTE:

All harness connectors should be inspected from the air bag diagnosis sensor unit to the end component (including any in-line connectors).

Is the inspection result normal?

- YES >> GO TO 2.
NO >> Perform one of the following repairs:
 - Visible damage: Replace the harness.
 - Loose terminal: Secure the terminal.
 - Poor connection: Secure the connection.

2. CONFIRM DTC

1. Reconnect all harness connectors.
2. Turn ignition switch ON.
3. Check for DTC using CONSULT.

Is DTC still current?

- YES >> GO TO 3.
NO >> Refer to [GI-43, "Intermittent Incident"](#).

3. WIRING HARNESS

Check the wiring harness for visible damage.

NOTE:

The entire wiring harness should be inspected from the air bag diagnosis sensor unit to the end component (including any in-line connectors).

Is the inspection result normal?

- YES >> GO TO 4.
NO >> Replace the harness.

4. CONFIRM DTC

1. Reconnect all harness connectors.
2. Turn ignition switch ON.
3. Check for DTC using CONSULT.

Is DTC still current?

- YES >> GO TO 5.
NO >> Refer to [GI-43, "Intermittent Incident"](#).

5. FRONT PASSENGER AIR BAG OFF INDICATOR

1. Replace the front passenger air bag off indicator.
2. Turn ignition switch ON.
3. Check for DTC using CONSULT.

Is DTC still current?

- YES >> GO TO 6.

A
B
C
D
E
F
G
I
J
K
L
M
N
O
P

SRC

SRS AIR BAG CONTROL SYSTEM

< WIRING DIAGRAM >

Connector No.	B110
Connector Name	SEAT BELT BUCKLE SWITCH RH
Connector Color	WHITE

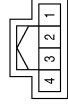

Terminal No.	Color of Wire	Signal Name
1	L	-
2	B	-

Connector No.	B107
Connector Name	WIRE TO WIRE
Connector Color	WHITE

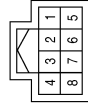

Terminal No.	Color of Wire	Signal Name
1	L	-
2	LG	-
3	Y/G	-
4	Y	-
5	G	-

Connector No.	B82
Connector Name	RH SIDE CURTAIN AIR BAG MODULE
Connector Color	YELLOW



Terminal No.	Color of Wire	Signal Name
1	Y	-
2	Y/B	-

Connector No.	B114
Connector Name	RH SIDE AIR BAG (SATELLITE) SENSOR
Connector Color	YELLOW



Terminal No.	Color of Wire	Signal Name
1	W	-
2	B	-

Terminal No.	Color of Wire	Signal Name
26	Y/B	ODS INPUT
29	L	RH BUCKLE SW INPUT
31	Y/B	S-RH1 (+)
32	Y	S-RH1 (-)
35	Y	C-RH1 (+)
36	Y/B	C-RH1 (-)
47	W	SATELLITE RH (+)
48	B	SATELLITE RH (-)
55	SHIELD	GND

Connector No.	B113
Connector Name	AIR BAG DIAGNOSIS SENSOR UNIT
Connector Color	YELLOW

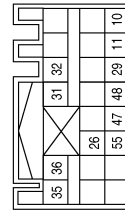

Terminal No.	Color of Wire	Signal Name
10	Y	P-RH1 (+)
11	Y/G	P-RH1 (-)

ABHIA0994GB

STARTING SYSTEM

< SYSTEM DESCRIPTION >

M/T WITHOUT CLUTCH INTERLOCK CANCEL SYSTEM : System Diagram

INFOID:000000012568948

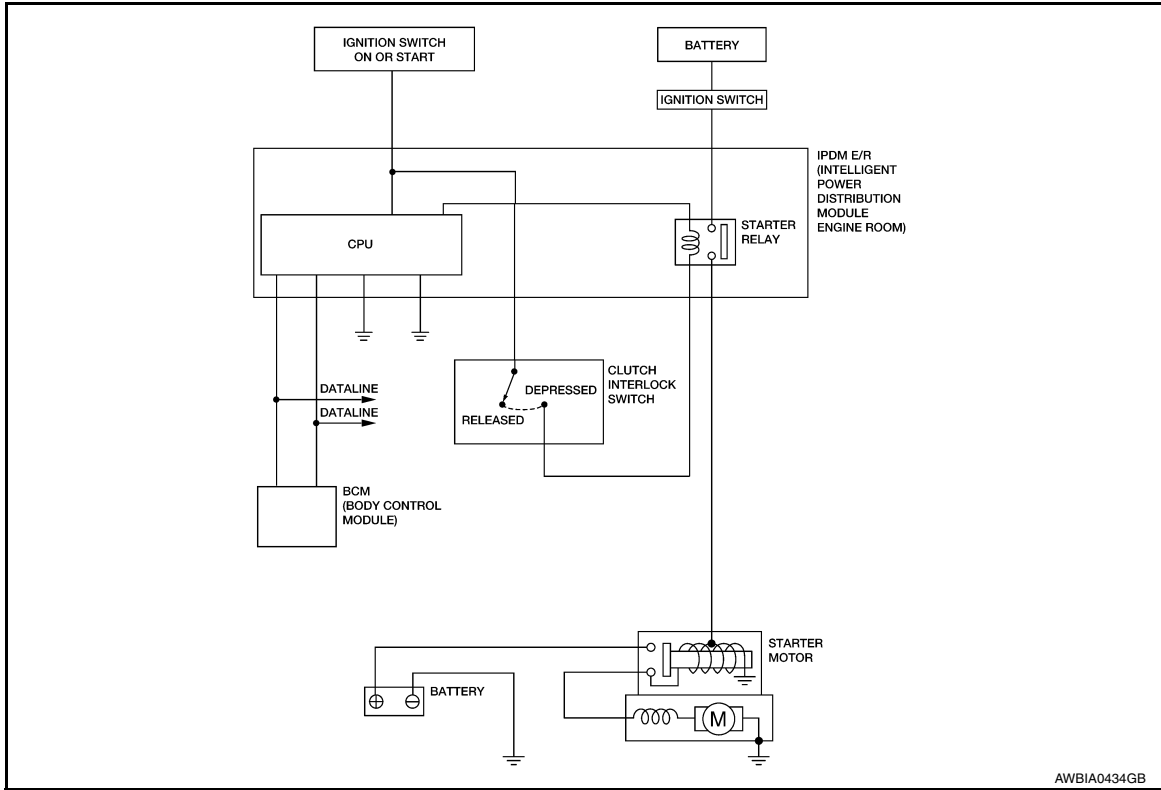

AWBIA0434GB

M/T WITHOUT CLUTCH INTERLOCK CANCEL SYSTEM : System Description

INFOID:000000012568949

The starter motor plunger closes and provides a closed circuit between the battery and the starter motor. The starter motor is grounded to the cylinder block. With power and ground supplied, the starter motor operates.

M/T WITHOUT CLUTCH INTERLOCK CANCEL SYSTEM : Component Parts Location

INFOID:000000012568950

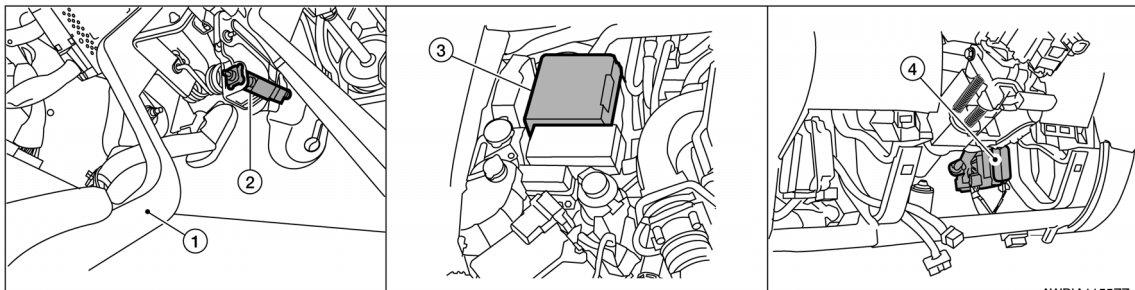

AWBIA1155ZZ

1. Clutch pedal
2. Clutch interlock switch E169
3. IPDM E/R E119, E120, E122, E124
4. BCM M18 (view with lower instrument panel LH removed)

CASE COMPONENTS

< UNIT DISASSEMBLY AND ASSEMBLY >

[FS5R30A]

8. Install front cover and gasket.

CAUTION:

Do not reuse bolts indicated as (A) shown.

Bolt symbol	Bolt length "ℓ" mm (in)	Tightening torque N·m (kg-m, ft-lb)
(A)	35 (1.38)	16-20 (1.6-2.1, 12-15)
(B)	30 (1.18)	
(C)	50 (1.97)	

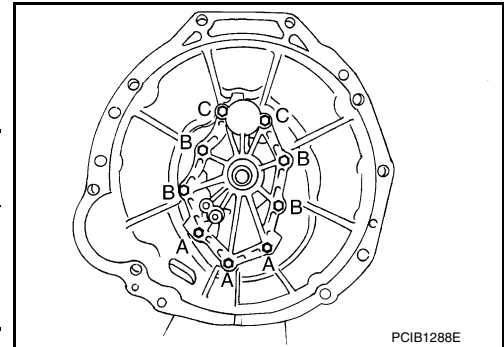

9. Apply sealant to mating surface of adapter plate.

- Use Genuine Silicone RTV or the equivalent. Refer to [GI-21, "Recommended Chemical Products and Sealants"](#).

10. Install rear extension together with striking arm.

Rear extension bolts Refer to [TM-23, "Overhaul"](#)

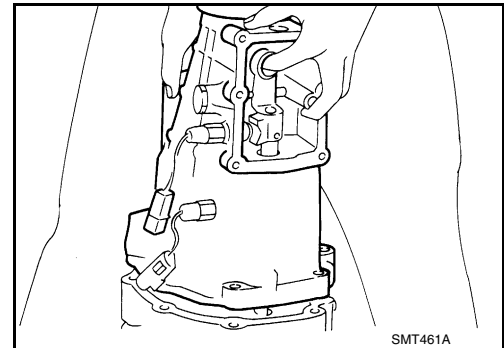

11. Install new retaining pin into striking arm using Tool.

Tool number : ST23540000 (J-25689-A)

CAUTION:

Do not reuse retaining pin.

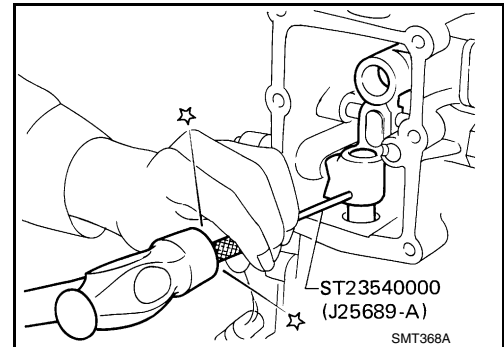

12. Install check ball and return spring.

13. Apply sealant to mating surface of rear extension, and then install control housing.

- Use Genuine Silicone RTV or the equivalent. Refer to [GI-21, "Recommended Chemical Products and Sealants"](#).

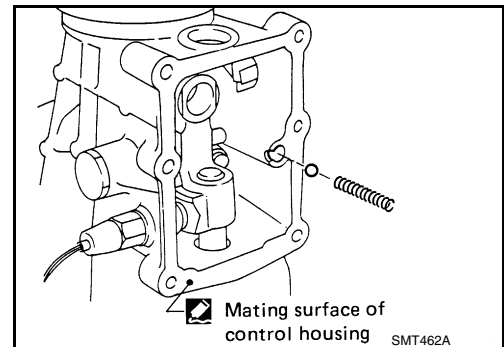

CASE COMPONENTS

< UNIT DISASSEMBLY AND ASSEMBLY >

[6MT: FS6R31A]

7. Install snap ring to main drive gear bearing using suitable tool.

CAUTION:
Do not reuse snap ring.

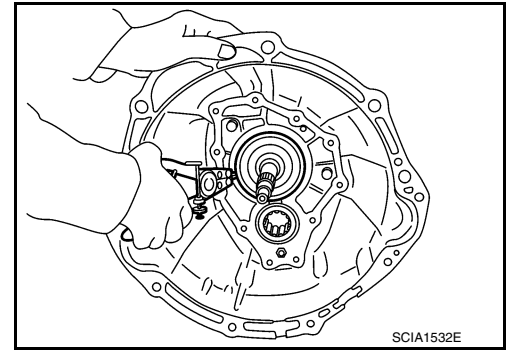

8. Tighten baffle plate nut to the specified torque. Refer to [TM-77](#), "[Overhaul](#)".

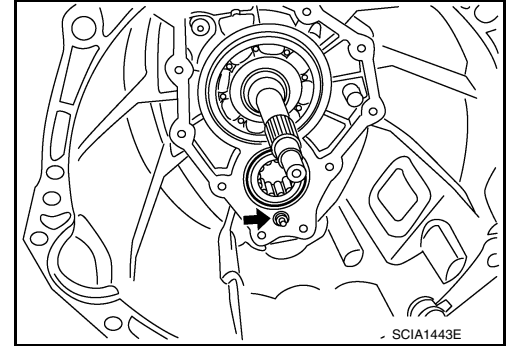

9. Tighten baffle plate bolt to the specified torque. Refer to [TM-77](#), "[Overhaul](#)".

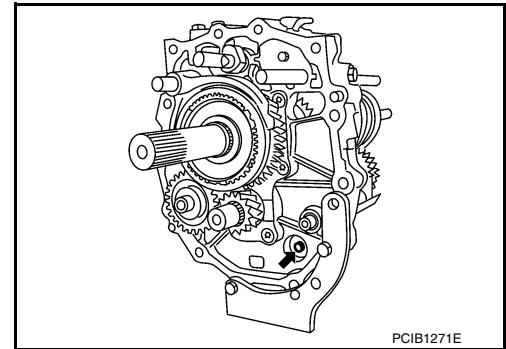

10. Install front cover oil seal to front cover using Tool.

Tool number : KV38102100 (J-25803-01)

Dimension (A) : 8.55 - 9.55 mm (0.336 - 0.376 in)

CAUTION:

- Do not reuse front cover oil seal.
- Apply multi-purpose grease onto oil seal lip.
- When installing, do not incline front cover oil seal.

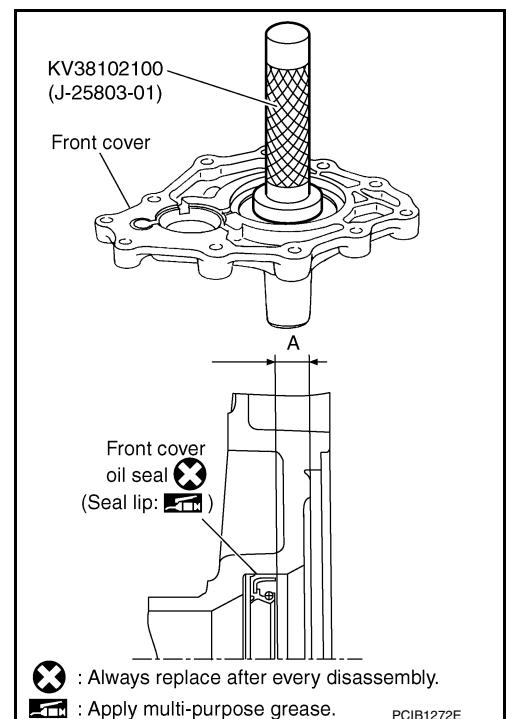

A/T CONTROL SYSTEM

< SYSTEM DESCRIPTION >

[5AT: RE5R05A]

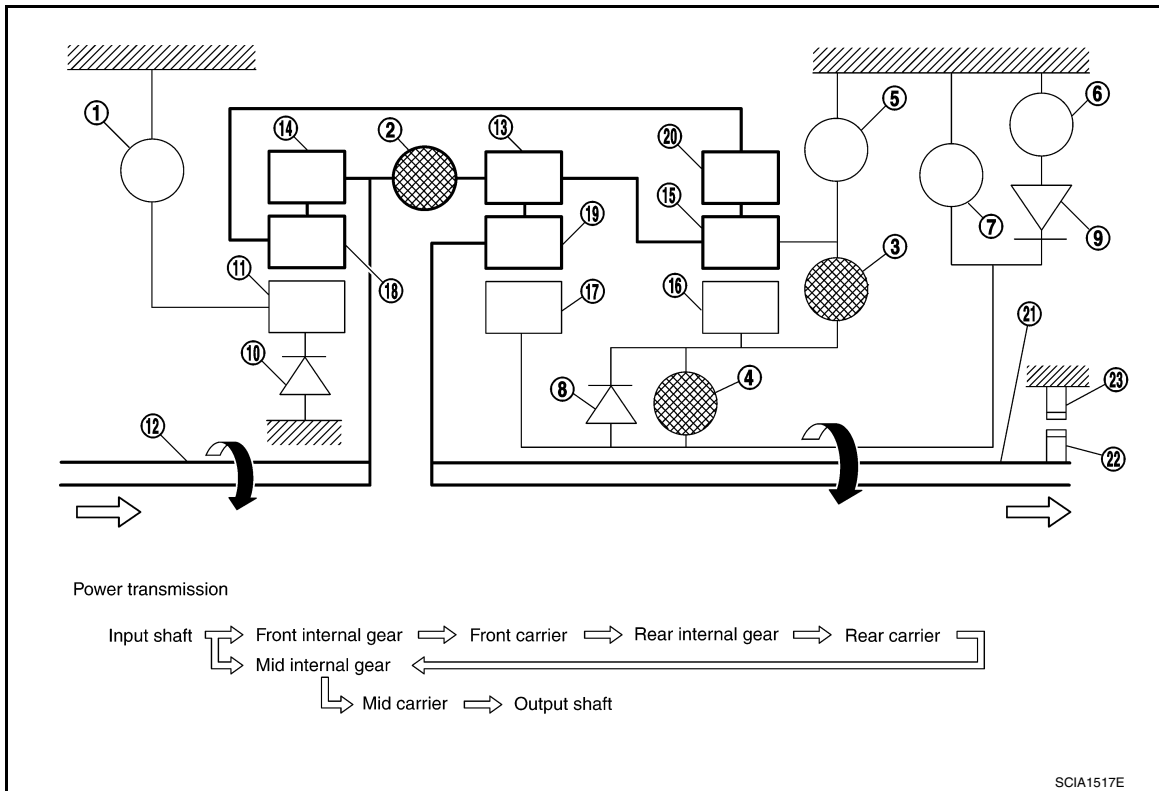

- | | | |
|--------------------------------|-------------------------|---------------------------|
| 1. Front brake | 2. Input clutch | 3. Direct clutch |
| 4. High and low reverse clutch | 5. Reverse brake | 6. Forward brake |
| 7. Low coast brake | 8. 1st one-way clutch | 9. Forward one-way clutch |
| 10. 3rd one-way clutch | 11. Front sun gear | 12. Input shaft |
| 13. Mid internal gear | 14. Front internal gear | 15. Rear carrier |
| 16. Rear sun gear | 17. Mid sun gear | 18. Front carrier |
| 19. Mid carrier | 20. Rear internal gear | 21. Output shaft |
| 22. Parking gear | 23. Parking pawl | |

"D5" Position

- The front brake fastens the front sun gear.
- The input clutch is coupled and the front internal gear and mid internal gear are connected.
- The high and low reverse clutch is coupled and the mid sun gear and rear sun gear are connected.

P1710 TRANSMISSION FLUID TEMPERATURE SENSOR

< DTC/CIRCUIT DIAGNOSIS >

[5AT: RE5R05A]

P1710 TRANSMISSION FLUID TEMPERATURE SENSOR

Description

INFOID:0000000012565965

The A/T fluid temperature sensor detects the A/T fluid temperature and sends a signal to the TCM.

CONSULT Reference Value in Data Monitor Mode

INFOID:0000000012565966

Item name	Condition °C (°F)	Display value (Approx.)
ATF TEMP SE 1	0 (32) - 20 (68) - 80 (176)	3.3 - 2.7 - 0.9 V

On Board Diagnosis Logic

INFOID:0000000012565967

- This is an OBD-II self-diagnostic item.
- Diagnostic trouble code “P1710 (A/T), P0710 (ENGINE)” with CONSULT or 10th judgment flicker without CONSULT is detected when:
 - TCM receives an excessively low or high voltage from the sensor.
 - A/T fluid temperature does not rise to the specified temperature after driving for a certain period of time.
 - There is a certain temperature difference between A/T fluid and engine coolant. (Except for Mexico)

Possible Cause

INFOID:0000000012565968

- Harness or connectors
(The sensor circuit is open or shorted.)
- A/T fluid temperature sensor

DTC Confirmation Procedure

INFOID:0000000012565969

CAUTION:

Always drive vehicle at a safe speed.

NOTE:

If “DTC Confirmation Procedure” has been previously performed, always turn ignition switch “OFF” and wait at least 10 seconds before performing the next test.

After the repair, perform the following procedure to confirm the malfunction is eliminated.

④ WITH CONSULT

Confirmation procedure 1

1. Turn ignition switch “ON”. (Do not start engine.)
2. Select “DATA MONITOR” mode for “TRANSMISSION” with CONSULT.
3. Start engine and maintain the following conditions for 10 seconds or more.
VHCL/S SE-A/T: 10 km/h (6 MPH) or more
ACCELE POSI: More than 1.0/8
SLCT LVR POSI: “D” position
4. If DTC is detected, go to [TM-199. "Diagnosis Procedure"](#).
5. If DTC is not detected, go to “Confirmation procedure 2”.

Confirmation procedure 2

1. Turn ignition switch “OFF” and cool the engine.
2. Turn ignition switch “ON”. (Do not start engine.)
3. Select “ATF TEMP 1” in “DATA MONITOR” mode for “TRANSMISSION” with CONSULT.
4. Record A/T fluid temperature.
5. If A/T fluid temperature is less than 20°C (68°F), go to “Confirmation procedure 3”.
6. If A/T fluid temperature is 20°C (68°F) or more, go to “Confirmation procedure 4”. (Except for Mexico)

Confirmation procedure 3

1. Select “DATA MONITOR” mode for “TRANSMISSION” with CONSULT.
2. Start the engine and wait for at least 3 minutes.
3. Drive the vehicle for the total minutes specified in the Driving time column below with the following conditions satisfied.
VHCL/S SE-A/T: 10 km/h (6 MPH) or more
ACCELE POSI: More than 0.5/8

SYSTEM SYMPTOM

< SYMPTOM DIAGNOSIS >

[5AT: RE5R05A]

No.	Items	Symptom	Condition	Diagnostic Item	Reference page
30	Slips/Will Not engage	No shock at all or the clutch slips when vehicle changes speed D4 → D5.	ON vehicle	1. Fluid level and state	TM-270
				2. Output speed sensor and vehicle speed signal	TM-175, TM-201
				3. Front brake solenoid valve	TM-209
				4. Direct clutch solenoid valve	TM-211
				5. CAN communication line	TM-167
				6. Line pressure test	TM-277
				7. Control valve with TCM	TM-289
			OFF vehicle	8. Torque converter	TM-314
				9. Oil pump assembly	TM-344
				10. Front brake (brake band)	TM-314
				11. Input clutch	TM-349
				12. Gear system	TM-314
				13. High and low reverse clutch	TM-359
31	Slips/Will Not engage	When you press the accelerator pedal and shift speed D5→ D4, the engine idles or the transmission slips.	ON vehicle	1. Fluid level and state	TM-270
				2. Output speed sensor and vehicle speed signal	TM-175, TM-201
				3. Front brake solenoid valve	TM-209
				4. Direct clutch solenoid valve	TM-211
				5. CAN communication line	TM-167
				6. Line pressure test	TM-277
				7. Control valve with TCM	TM-289
			OFF vehicle	8. Torque converter	TM-314
				9. Oil pump assembly	TM-344
				10. Input clutch	TM-349
				11. Gear system	TM-314
				12. High and low reverse clutch	TM-359
				13. Direct clutch	TM-361

A
B
C
TM
E
F
G
H
I
J
K
L
M
N
O
P

TRANSMISSION ASSEMBLY

< UNIT REMOVAL AND INSTALLATION >

[5AT: RE5R05A]

CAUTION:

Do not reuse copper sealing washers.

12. Remove the dust cover from the converter housing.
13. Turn the crankshaft to access and remove the four bolts for the drive plate and torque converter.

CAUTION:

When turning the crankshaft, turn it clockwise as viewed from the front of the engine.

14. Support the A/T assembly using a transmission jack.

CAUTION:

When setting the transmission jack, be careful not to allow it to collide against the drain plug.

15. Remove the nuts securing the insulator to the crossmember.
16. Remove the crossmember using power tool.

WARNING:

Support the transmission using suitable jack.

17. Tilt the transmission slightly to gain clearance between the body and the transmission, then disconnect the air breather hose.
18. Disconnect the A/T assembly harness connector.
19. Remove the harness from the retainers.
20. Remove the A/T fluid indicator pipe.
21. Remove the A/T assembly to engine bolts using power tool.
22. Remove A/T assembly from the vehicle using Tool.

Tool number : — (J-47002)

CAUTION:

- Secure the torque converter to prevent it from dropping.
- Secure the A/T assembly to a transmission jack.

NOTE:

The actual special service Tool may differ from Tool shown.

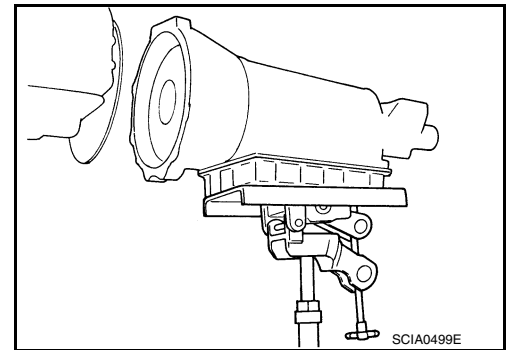
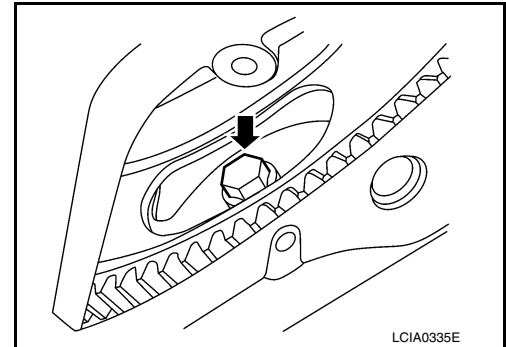

INSPECTION

Installation and Inspection of Torque Converter

- After inserting a torque converter to a transmission, be sure to check dimension (A) to ensure it is within the reference value limit.

Dimension (A) : 25.0 mm (0.98 in) or more

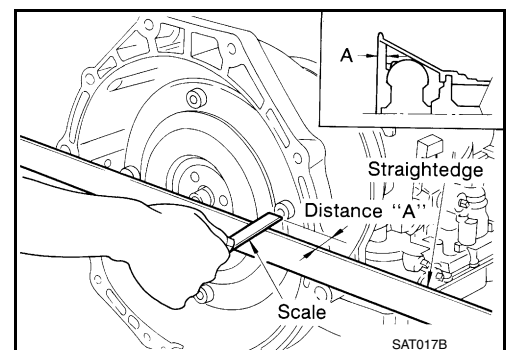

INSTALLATION

Installation of the remaining components is in the reverse order of the removal, while paying attention to the following.

DIRECT CLUTCH

< UNIT DISASSEMBLY AND ASSEMBLY >

[5AT: RE5R05A]

2. Install snap ring in direct clutch drum using suitable tool.

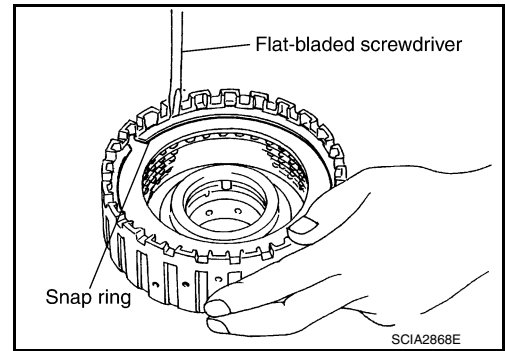

A
B
C

TM

E
F
G
H
I
J
K
L
M
N
O
P

Diagnosis Procedure	22	SYMPTOM DIAGNOSIS	44
Component Inspection	23		
ECU DIAGNOSIS INFORMATION	24	THE LIGHT REMINDER WARNING DOES	
		NOT SOUND	44
COMBINATION METER	24	Description	44
Reference Value	24	Diagnosis Procedure	44
Fail Safe	25	THE SEAT BELT WARNING CONTINUES	
DTC Index	26	SOUNDING, OR DOES NOT SOUND	45
BCM (BODY CONTROL MODULE)	27	Description	45
Reference Value	27	Diagnosis Procedure	45
Terminal Layout	30	THE KEY WARNING DOES NOT SOUND	46
Physical Values	30	Description	46
Fail Safe	35	Diagnosis Procedure	46
DTC Inspection Priority Chart	35	PRECAUTION	47
DTC Index	36		
WIRING DIAGRAM	38	PRECAUTIONS	47
		Precaution for Supplemental Restraint System	
WARNING CHIME SYSTEM	38	(SRS) "AIR BAG" and "SEAT BELT PRE-TEN-	
Wiring Diagram	38	SIONER"	47

TPMS

< SYSTEM DESCRIPTION >

A sensor-transmitter integrated with a valve is installed in each wheel, and transmits a detected air pressure signal in the form of a radio wave. The radio signal is received by the remote keyless entry receiver.

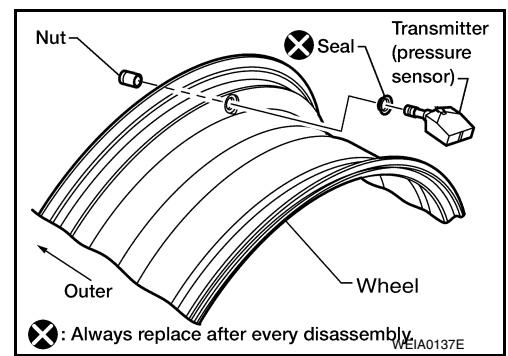

REMOTE KEYLESS ENTRY RECEIVER

The remote keyless entry receiver is shown with the instrument panel RH removed. The remote keyless entry receiver receives the air pressure signal transmitted by the transmitter in each wheel.

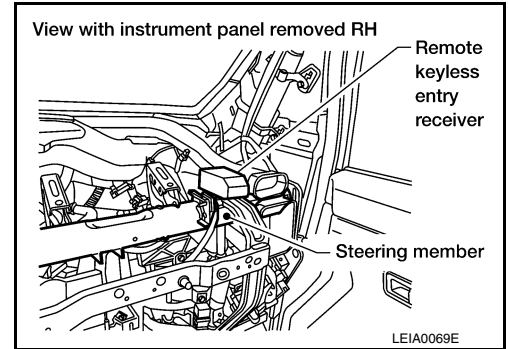

COMBINATION METER

The combination meter receives tire pressure status from the BCM using CAN communication. When a low tire pressure condition is sensed by the BCM, the combination meter low tire pressure warning lamp is activated. A CHECK TIRE PRES warning message will also be displayed in the vehicle information display. Refer to the Owner's Manual for additional information.

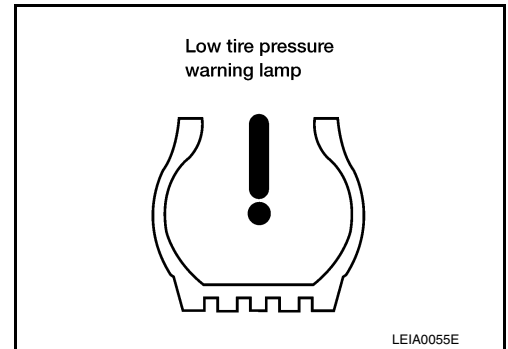

TIRE PRESSURE WARNING CHECK CONNECTOR

The tire pressure warning check connector can be grounded in order to initiate self-diagnosis without a CONSULT. Refer to [WT-13. "Self-Diagnosis \(Without CONSULT\)"](#). The tire pressure warning check connector (1) is located behind the lower portion of the instrument panel LH.

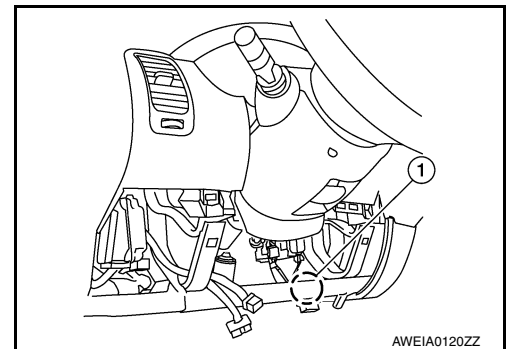

CLICK HERE TO **DOWNLOAD** THE COMPLETE MANUAL

- Thank you very much for reading the preview of the manual.
- You can download the complete manual from: www.heydownloads.com by clicking the link below



- Please note: If there is no response to CLICKING the link, please download this PDF first and then click on it.

CLICK HERE TO **DOWNLOAD** THE COMPLETE MANUAL