

# 2016 SERVICE MANUAL



**WILDCAT<sup>®</sup> X/4X**



[www.arcticcat.com](http://www.arcticcat.com)

CLICK HERE TO **DOWNLOAD** THE COMPLETE MANUAL

- Thank you very much for reading the preview of the manual.
- You can download the complete manual from: [www.heydownloads.com](http://www.heydownloads.com) by clicking the link below



- Please note: If there is no response to CLICKING the link, please download this PDF first and then click on it.

CLICK HERE TO **DOWNLOAD** THE COMPLETE MANUAL

A new spark plug should be tightened 1/2 turn once the washer contacts the cylinder head. A used spark plug should be tightened 1/8-1/4 turn once the washer contacts the cylinder head.

---

---

## Muffler/Spark Arrester

---

Clean the spark arrester using the following procedure.

**⚠ WARNING**

Wait until the muffler cools to avoid burns.

1. Remove the machine screw securing the spark arrester to the muffler.



WC900

2. Remove the spark arrester screen; then using a suitable brush, clean the carbon deposits from the screen taking care not to damage the screen.

■NOTE: If the screen is damaged in any way, it must be replaced.

3. Install the spark arrester assembly and secure with the machine screw. Tighten the cap screw to 6 ft-lb.

---

---

## Engine/Transmission Oil - Filter

---

### OIL - FILTER

Change the engine oil and oil filter at the scheduled intervals. The engine should always be warm when the oil is changed so the oil will drain easily and completely.

1. Park the vehicle on level ground.
2. Remove the oil level stick/filler plug.

**⚠ WARNING**

Use caution when removing oil level stick. Exhaust components may be extremely hot.

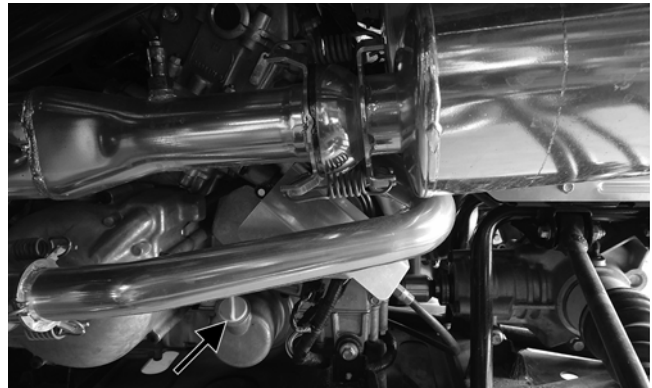

WC895A

3. Remove the drain plug from the bottom of the engine and drain the oil into a drain pan. Account for and discard the gasket.

**⚠ WARNING**

Use extreme caution when removing the oil drain plug. Hot oil can cause severe injury and skin burns.

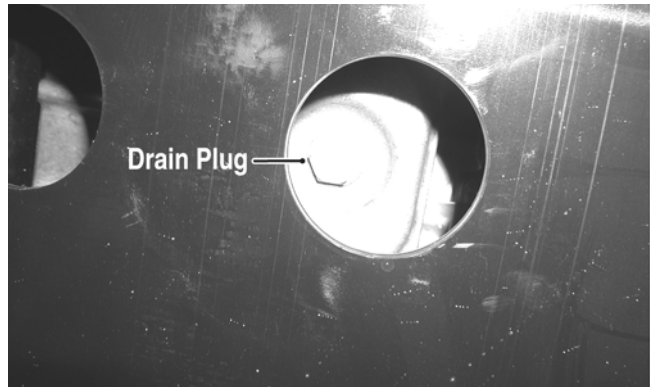

PR078A

4. Using the Oil Filter Wrench and a ratchet handle (or a socket or box-end wrench), remove the old oil filter. Account for and discard the O-ring.

■NOTE: Clean up any excess oil after removing the filter.

5. Apply oil to a new filter O-ring and check to make sure it is positioned correctly; then install the new oil filter. Tighten securely.
6. Install the engine drain plug with new gasket and tighten to 20 ft-lb. Pour the specified amount of the recommended oil in the filler hole. Install the oil level stick/filler plug.
7. Start the engine (while the vehicle is outside on level ground) and allow it to idle for a few minutes.
8. Turn the engine off and wait approximately one minute.
9. Unscrew the oil level stick and wipe it with a clean cloth.
10. Install the oil level stick and thread into the engine case.

■NOTE: The oil level stick should be threaded into the case for checking the oil level.

- Remove the steering flex-shaft support bracket; then slide the EPS unit upwards and to the rear until clear of the steering rack input coupler.

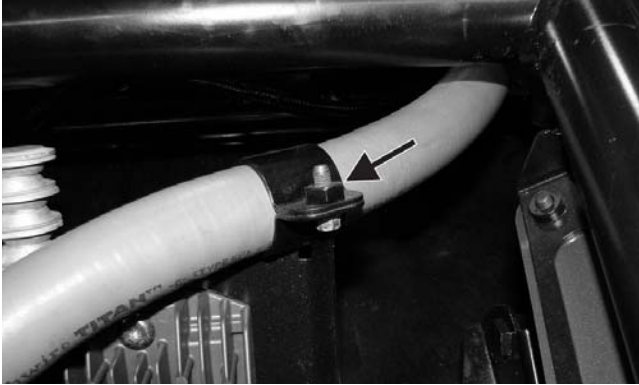

WC247A

- Remove the steering flex-shaft coupler from the EPS unit; then maneuver the assembly past the brake hoses and out of the vehicle.

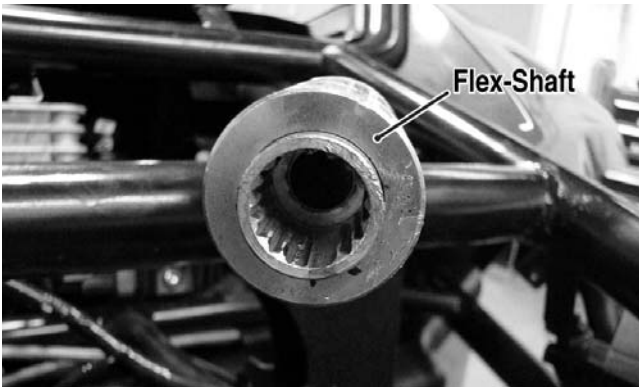

WC253A

- Remove the four cap screws securing the EPS mounting bracket to the EPS unit.

■NOTE: No repairs are authorized on the EPS assembly and it must be replaced as a complete assembly.

### INSTALLING EPS

- Install the EPS mounting bracket onto the EPS unit and secure with the four cap screws. Tighten to 35 ft-lb.
- Mark the ends of the EPS input and output shafts to correspond with the flat-splined segment; then align the flat-splined segment of the output shaft with the slot in the rack input coupler and install the EPS into the vehicle.



WC254A



WC249A

- Rock the EPS assembly to seat the splines and mounting bracket.

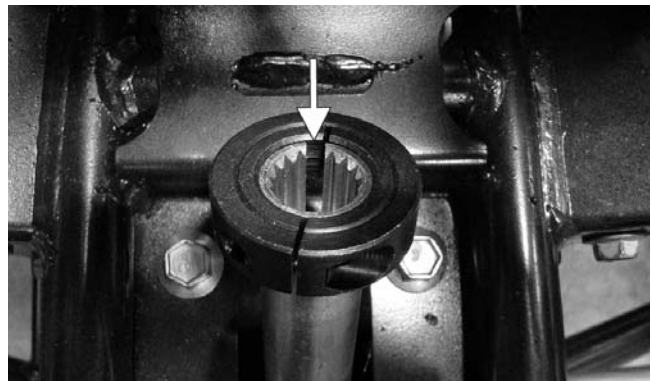

WC250A

- Secure the mounting bracket to the frame and tighten to 20 ft-lb.
- Install the steering flex-shaft coupler onto the EPS input shaft aligning the flat-splined segment of the shaft to the slot in the coupler.

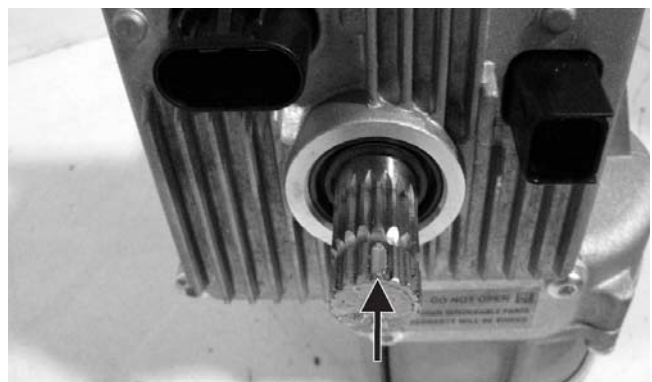

WC251A

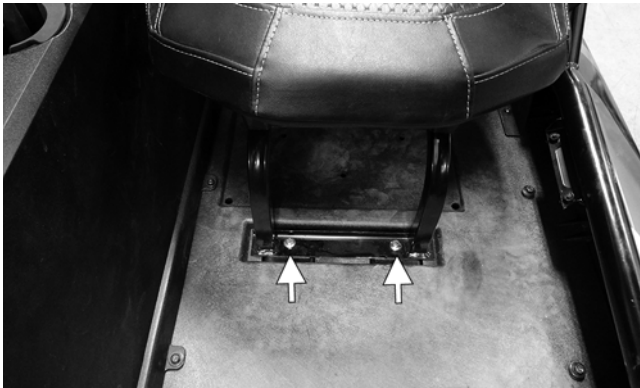

WC722A

4. To install a rear seat, place into position with the seat support; then secure with the cap screws and tighten to 15 ft-lb.

## Doors

### CHECKING/ADJUSTING (X/4X)

The doors and latches are adjustable for proper latching/unlatching.

1. To raise or lower door-to-latch contact or to move the door forward or backward, loosen the screws on the hinge plate. After adjustment, tighten securely.

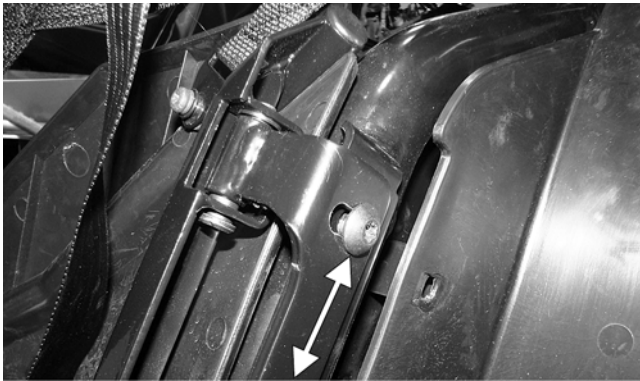

WC134A



WC109A

2. To move latch forward or aft, loosen the screws on the latch plate. After adjustment, tighten securely.



WC133A

### CHECKING/ADJUSTING (X Limited)

1. Loosen the screws on the hinge plate to raise or lower the door-to-latch contact or to move the door forward or backward. After adjustment, tighten securely.



WC801A

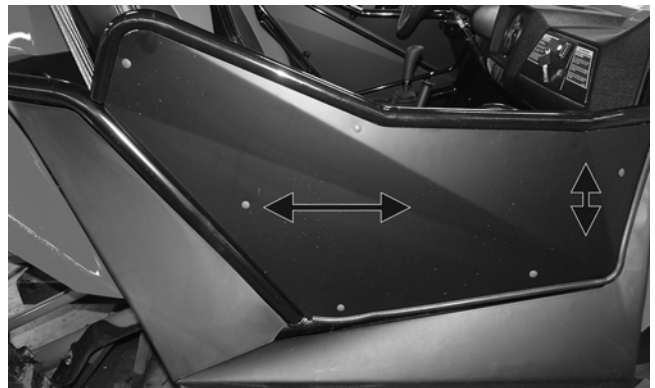

WC798A

2. Loosen the screws on the latch plate to move the latch forward or backward. After adjustment, tighten securely.

## Roof (X Limited)

### REMOVING/INSTALLING

1. Remove the cap screws and lock nuts securing the P-clamps to the roof. Account for the washers and discard the lock nuts.

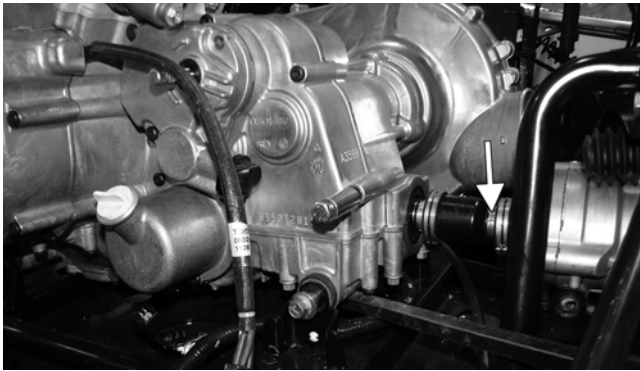

WC172B

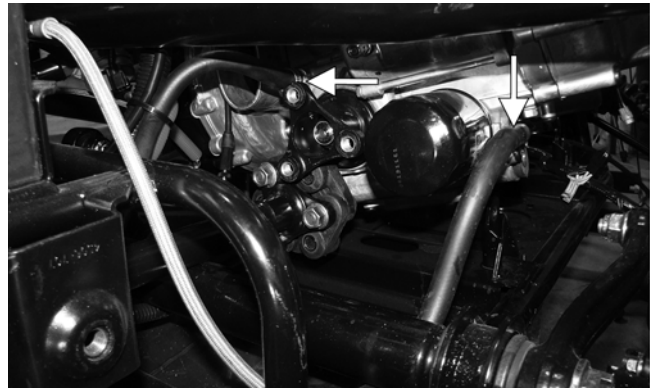

WC174A

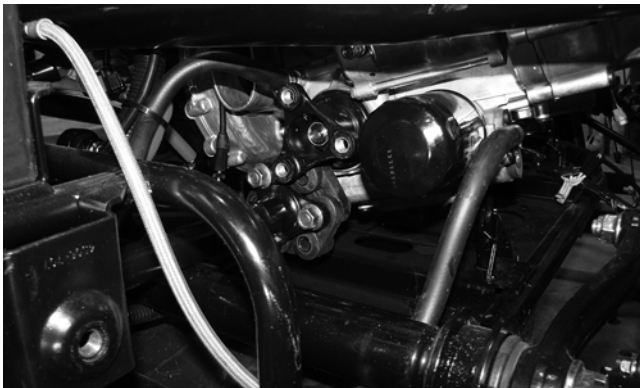

WC174

27. Move the engine forward sufficiently to disengage the spline shaft on the rear drive coupler and lift the engine just free of the mounts; then clamp off the oil cooler hoses and disconnect from the engine. Account for the spring.

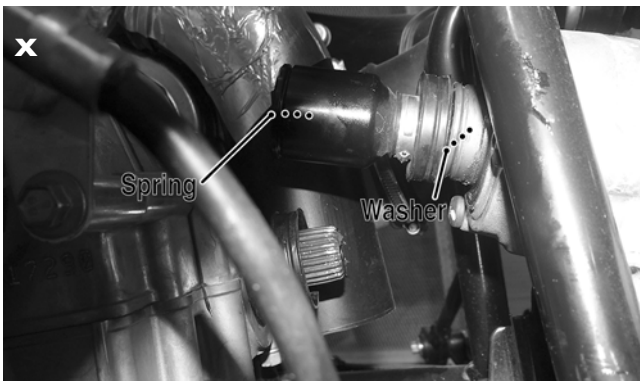

WC767A

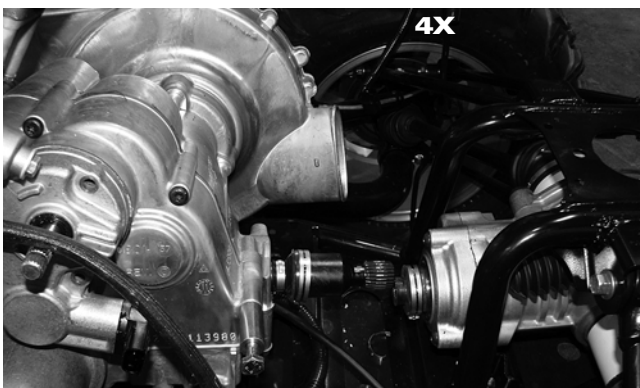

WC173

## Top-Side Components

■NOTE: For efficiency, it is preferable to remove and disassemble only those components which need to be addressed and to service only those components. The technician should use discretion and sound judgment.

### AT THIS POINT

To service any one specific component, only limited disassembly of components may be necessary. Note the AT THIS POINT information in each sub-section.

■NOTE: The engine/transmission does not need to be removed for this procedure.

## Removing Top-Side Components

### A. Valve Cover/Rocker Arms B. Cylinder Head/Camshaft

1. Remove the timing inspection plug, spark plugs, and magneto housing cover; then install the 10 mm cap screw (left-hand threads) in the crankshaft and rotate the desired cylinder to top-dead-center of the compression stroke.



GZ027

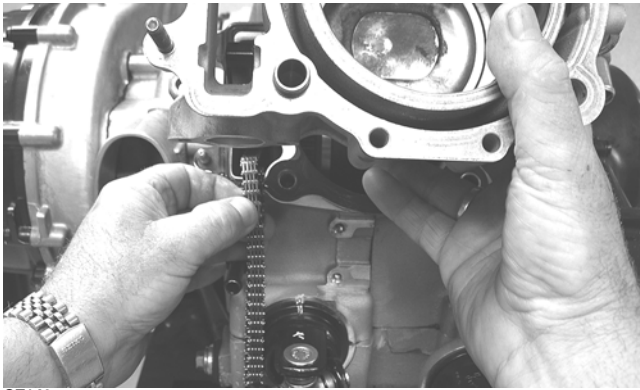

GZ142

4. Loosely install the two nuts securing the cylinder to the crankcase.

■NOTE: The two cylinder-to-crankcase nuts will be tightened in step 10.

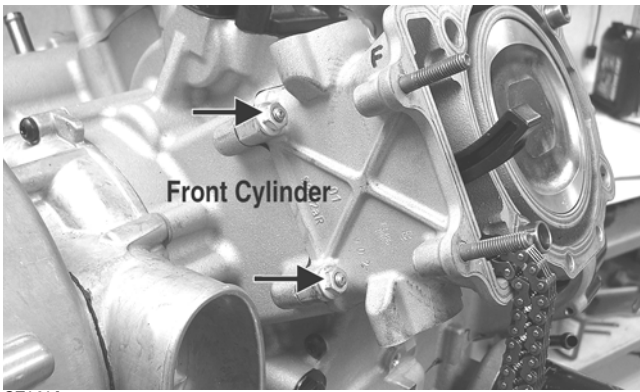

GZ141A

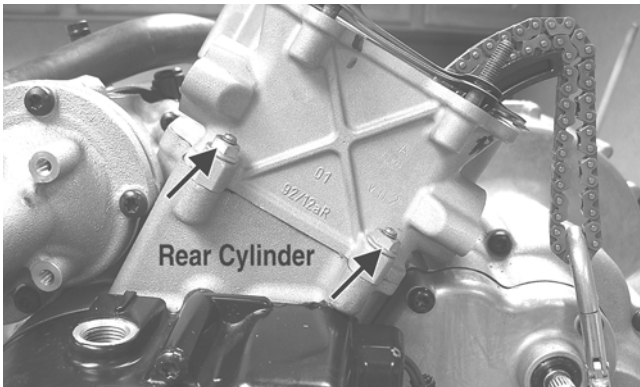

GZ160A

5. Install the coolant hose onto the crankcase union and tighten the clamp.

### C. Cylinder Head

### D. Valve Cover

■NOTE: Steps 1-5 in the preceding sub-section must precede this procedure.

6. Place the chain guide into the cylinder.

### CAUTION

Care should be taken that the bottom of the chain guide is secured in the crankcase boss.



GZ161A

7. Place a new head gasket into position on the cylinder. Place the alignment pins into position; then place the head assembly into position on the cylinder while guiding the cam chain through the cylinder head.

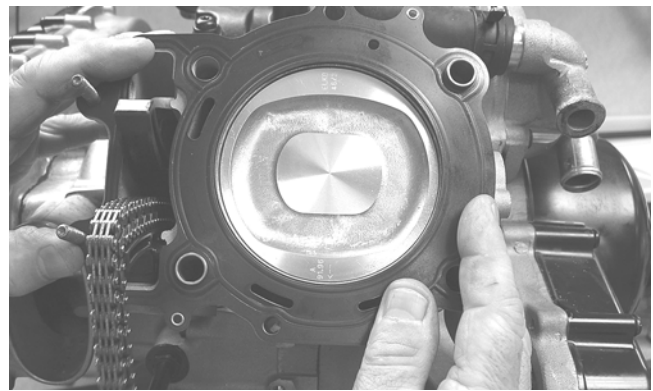

GZ151

8. Install the cylinder head cap screws. Tighten only until snug.

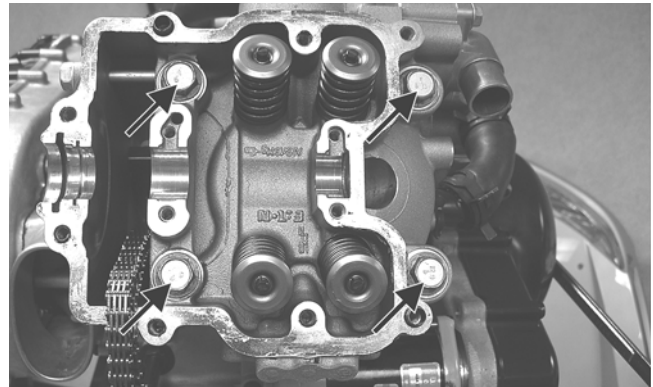

GZ132B

9. Loosely install the five cylinder head nuts.

10. In a crisscross pattern, tighten the four cylinder head cap screws (from step 8) initially to 20 ft-lb; then increase to 30 ft-lb, and finally to 37 ft-lb. Tighten the 8 mm nut (from step 9) to 21 ft-lb; then using a crisscross pattern, tighten the 6 mm nuts (from step 9) to 8.5 ft-lb. Tighten the two cylinder-to-crankcase nuts (from step 4) to 21 ft-lb.

■NOTE: If both cylinders have been removed, repeat steps 1-10 for the remaining cylinder.

3. Install the new stator coil assembly and secure with three cap screws using a drop of red Loctite #271 on each. If installing the existing magneto cover, tighten the cap screws to 13 ft-lb. If installing a new magneto cover, tighten the cap screws to 15 ft-lb.
4. Place the stator wire harness hold-down into position; then install the crankshaft position sensor and secure with two cap screws. Tighten securely.
5. Install the upper cable hold-down and secure with two cap screws. Tighten securely.

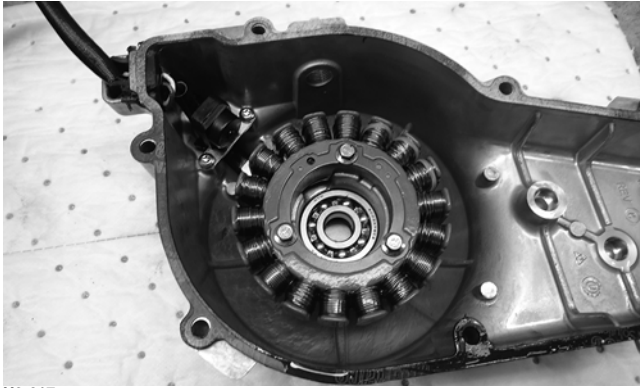

H2-017

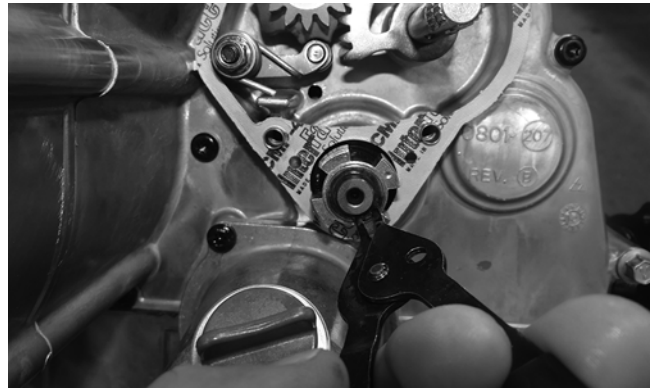

H2-023

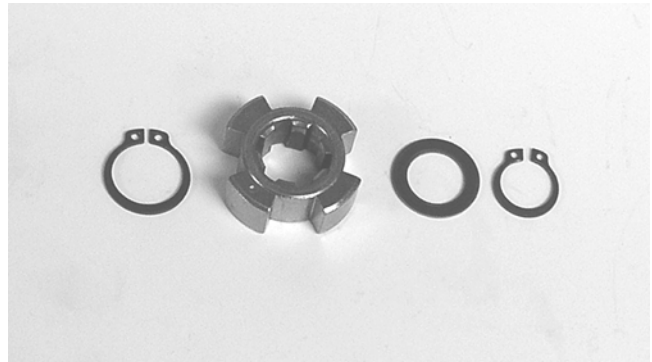

GZ254

## Installing Left-Side Components

1. Thoroughly clean all gasket material and sealant from mating surfaces.
2. Install a new O-ring on the oil filler cover and coat it with clean engine oil; then install the oil filler cover into the crankcase and secure with the cap screws. Tighten to 8 ft-lb.



GZ250

3. Clean the countershaft and trigger splines thoroughly and install the inner snap ring onto the shaft; then apply green Loctite #620 to the trigger and countershaft splines and install the trigger. Secure with a flat washer and outer snap ring.

4. If removed, install the shim (E) and cam stopper (F); then with the cam stopper support (B) in place, install the spring (C), washer (D), and nut (A). Tighten to 8 ft-lb.

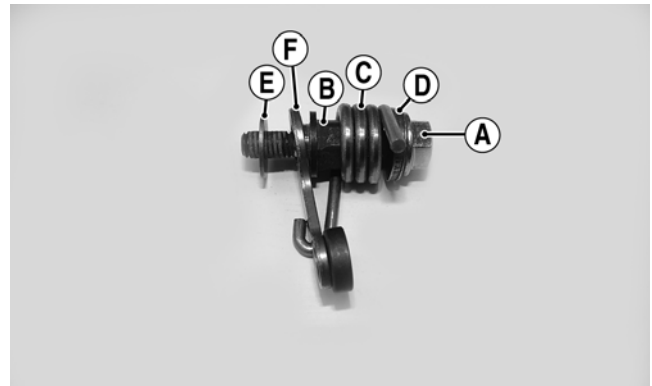

FW-017B

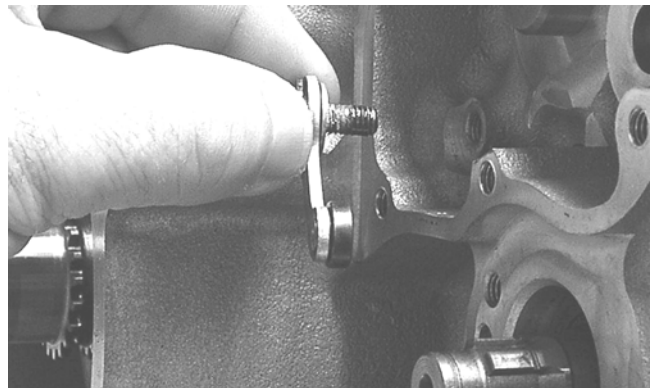

GZ256

5. Install the shift cam stopper spring onto the shift cam stopper and secure with a flat washer and flange nut. Tighten to 8 ft-lb.

CLICK HERE TO **DOWNLOAD** THE COMPLETE MANUAL

- Thank you very much for reading the preview of the manual.
- You can download the complete manual from: [www.heydownloads.com](http://www.heydownloads.com) by clicking the link below



- Please note: If there is no response to CLICKING the link, please download this PDF first and then click on it.

CLICK HERE TO **DOWNLOAD** THE COMPLETE MANUAL

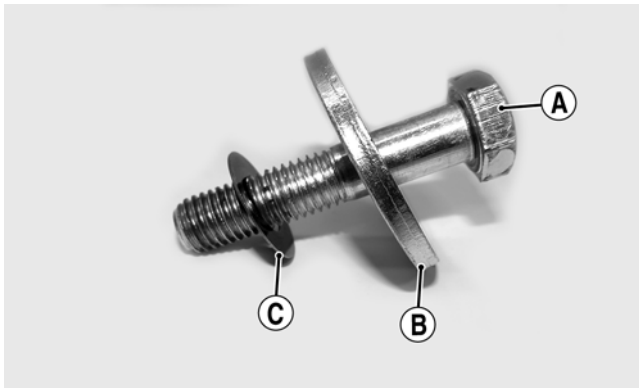

WC741A

8. Place the transmission in neutral and rotate the driven clutch and drive belt by hand in a clockwise direction for three complete revolutions.

■NOTE: Do not rotate in a counter clockwise direction as this will produce an inaccurate reading.

9. Verify 0.8 mm (0.030") clearance between stationary sheave on drive clutch and drive belt by using a feeler gauge with flat against the sheave. Check for slight resistance with gauge between sheave and belt.



WC739

10. If offset adjustment is necessary, place the transmission in park. Remove the driven clutch cap screw (A), washer (B), and any shims (C). If belt clearance is too small, add additional shims to gain the desired clearance. If belt clearance is too large, remove shims to gain the desired clearance.

11. Install the cap screw (A), washer (B), and shim(s) (C). Tighten the screw to 60 ft-lb.

12. Repeat steps 8-11 until proper clearance is achieved.

13. Place the CVT cover gasket into position; then with the two alignment pins in position, install the cover and secure with the cap screws. Tighten the cap screws to 8 ft-lb.

## Center Crankcase Components

■NOTE: This procedure cannot be done with the engine/transmission in the frame. Complete Removing procedures for Top-Side, Left-Side, and Right-Side must precede this procedure.

■NOTE: For efficiency, it is preferable to remove and disassemble only those components which need to be addressed and to service only those components. The technician should use discretion and sound judgment.

## Separating Crankcase Halves

1. Remove the oil strainer cap; then remove the oil strainer.

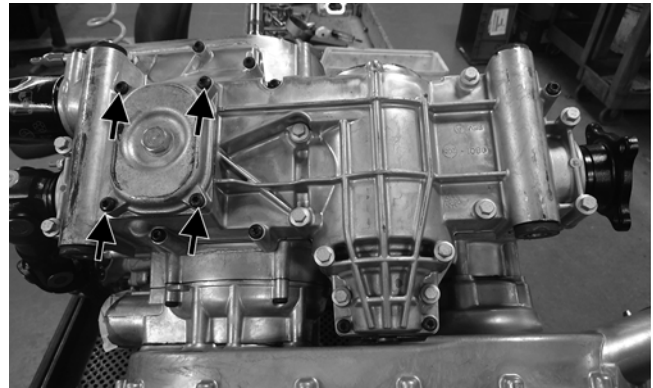

H2-012A

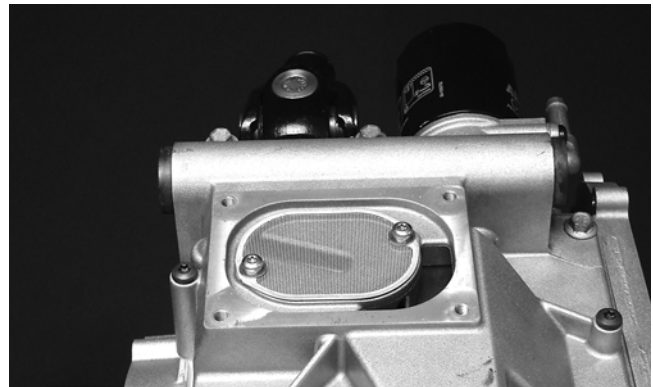

GZ446

2. Remove the cap screws securing the lower crankcase to the upper crankcase halves; then using a rubber hammer, free the lower crankcase and remove. Account for two alignment pins.

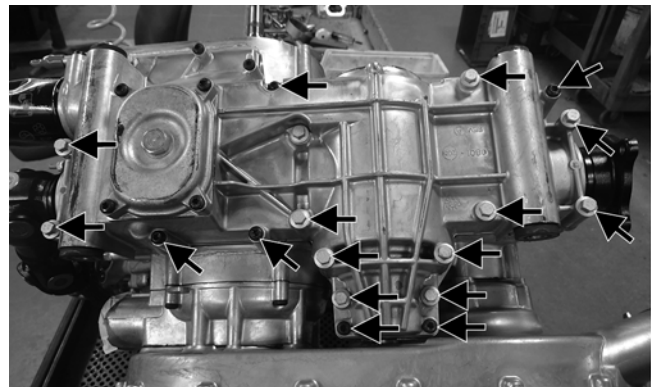

H2-012B

3. Remove the secondary drive assembly; then remove the secondary driven shaft assembly and set aside. Account for one locating ring.

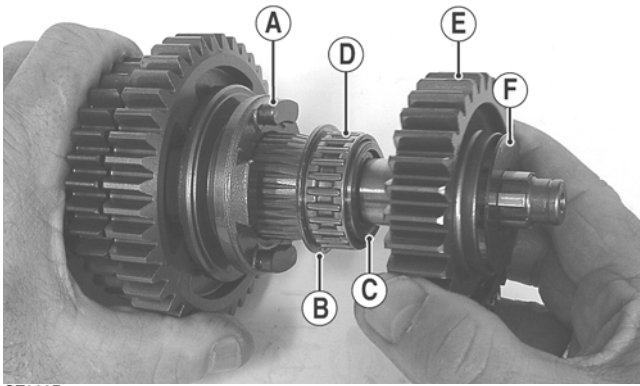

GZ283B

7. Install the drive gear washer and the shift forks. The countershaft is now ready for installation.

## Assembling Crankcase Half

1. Install the oil pump gerotor assembly and oil pump cover in the crankcase and secure with two cap screws. Coat the threads with red Loctite #271 and tighten securely to 8 ft-lb.

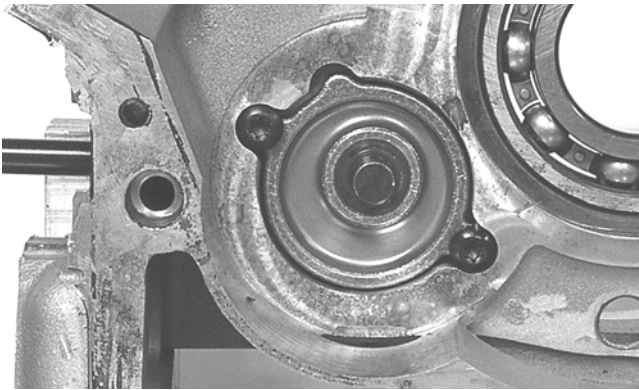

GZ305

2. Install a flat washer, drive pin, and drive gear onto the oil pump shaft; then secure with a snap ring (flat-side away from the gear).

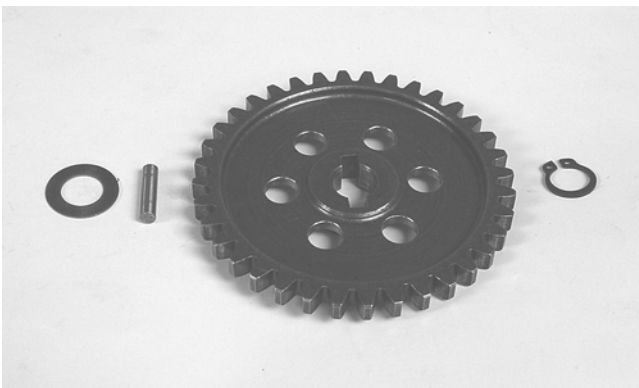

GZ347

3. Install the countershaft into the crankcase and secure with the snap ring (flat side away from the bearing).

■NOTE: To aid in installing, install the open end of the snap ring over the flat surface of the water pump countershaft.

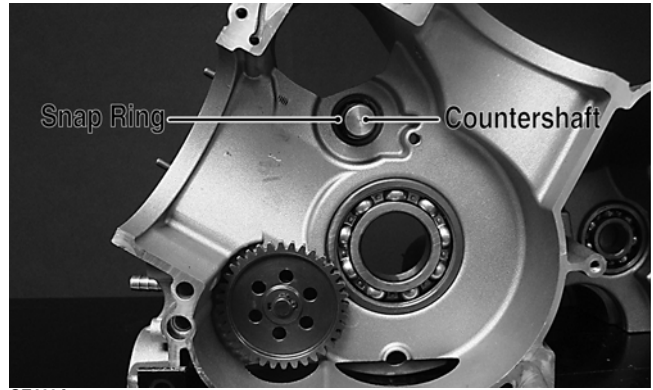

GZ463A

4. Install the countershaft gear onto the countershaft and secure with a snap ring (flat-side away from the gear).

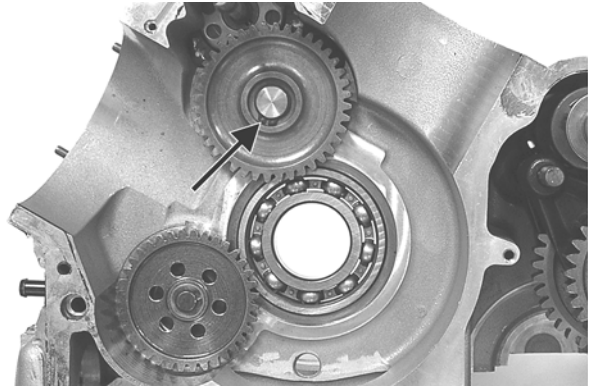

GZ299A

5. Using rubber bands to support the connecting rods, carefully install the crankshaft assembly into the crankcase.

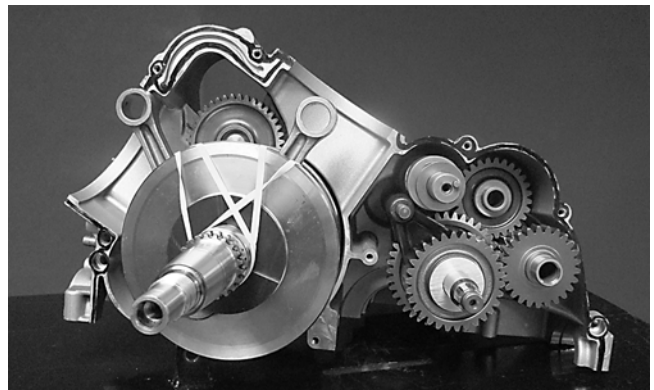

GZ474

■NOTE: It will be necessary to rotate the crankshaft back and forth to engage the teeth of the oil pump and countershaft gears.

6. Install the driveshaft; then with a flat washer on each end of the reverse idler assembly, install into the crankcase.

3. Inspect the driveshaft and driven sprocket for damage.
4. Inspect the crankcase for scoring, cracks, or damage.

### ASSEMBLING/INSTALLING

1. Place the rotors into the crankcase making sure the dowel pin is in the groove of the rotor.
2. Place the cover onto the crankcase.
3. Secure the pump with the two cap screws coated with blue Loctite #243. Tighten to 8 ft-lb.

## Oil Cooler

### REMOVING

1. Remove the hood.
2. Loosen the clamps securing the oil hoses to the oil cooler; then place an absorbent towel under the connection and remove the hoses.
3. Remove the cap screws from the oil cooler mountings and remove the oil cooler.

### CLEANING AND INSPECTING

1. Prior to washing, inspect the oil cooler for signs of leaks such as oily dirt build-up.
2. Wash the cooling fins using a garden hose and hot, soapy water and a soft brush.
3. Inspect all mounting brackets and the oil inlet and outlet for cracks or bends.

### INSTALLING

1. Place the oil cooler into position and secure with the existing hardware. Tighten securely.
2. Connect the oil hoses and secure with the hose clamps. Tighten securely.
3. Install the hood.

## Liquid Cooling System

When filling the cooling system, use premixed Arctic Cat Antifreeze. While the cooling system is being filled, air pockets may develop; therefore, open the bleed screw on the upper coolant pipe or the water pump housing to allow air to bleed from the cooling system. When clear coolant (no bubbles) is present, tighten the bleed screw securely; then fill the cooling system to the bottom of the stand pipe in the radiator neck. Run the engine for five minutes after the initial fill, shut the engine off, and then “top-off” the cooling system to the bottom of the stand pipe in the radiator neck.

### CAUTION

After operating the vehicle for the initial 5-10 minutes, stop the engine, allow the engine to cool down, and check the coolant level. Add coolant as necessary.

## Radiator

### REMOVING

1. Remove the seats.
2. Remove the rear body panel (see Steering/Body/Controls) and cap the gas tank fill hose; then remove the cargo box (see Steering/Body/Controls).
3. Disconnect the cooling fan electrical connectors and pry the harness anchors from the radiator frame and coil bracket.

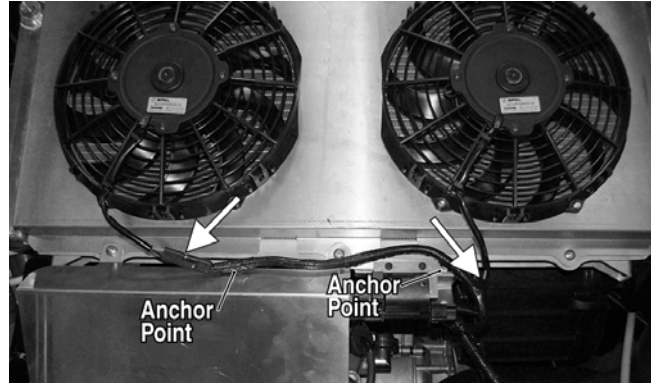

WC180B

4. Remove the screws securing the heat shield to the radiator frame and disconnect the coil primary connector; then remove the spark plug wire from the spark plug.

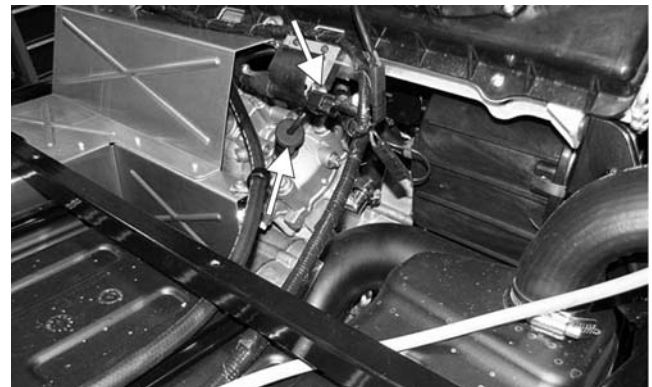

WC357A

5. Clamp the coolant hoses off; then loosen the coolant hose clamps.



WC192

## VOLTAGE (Taillight)

■NOTE: Perform this test at the socket end of the taillight-brakelight harness (pigtail). The ignition switch must be in the ON position and either high beam or low beam selected on the light switch.

1. Set the meter selector to the DC Voltage position.
2. Connect the black tester lead to the black wire; then connect the red tester lead to the white wire.
3. With the ignition key ON and the switch in the HI or LOW position, the meter must show battery voltage.

■NOTE: If battery voltage is not shown and the headlights are illuminated, inspect the three-wire connector in the left-rear canopy tube at the juncture of the canopy tube and lower frame. If battery voltage is shown on the meter, replace the LED.

## VOLTAGE (Brakelight)

■NOTE: Perform this test at the socket end of the taillight/brakelight harness (pigtail). The ignition switch must be in the ON position.

1. Set the meter selector to the DC Voltage position.
2. Connect the red tester lead to the red/blue wire; then connect the black tester lead to the black wire.
3. With the brake applied, the meter must show battery voltage.

■NOTE: If the meter shows no voltage, inspect the 10 amp ignition (IGN) fuse, brakelight switch, wiring harness, or connectors.

---

---

## Power Distribution Module (PDM)

---

### FUSES/RELAYS

■NOTE: To access fuses and relays, compress the locking tabs on either side of the PDM cover and lift off.

The fuses are located in a power distribution module under the passenger's seat. If there is any type of electrical system failure, always check the fuses first.

The 4-pin relays are identical plug-in type located on the power distribution module. Relay function can be checked by switching relay positions. The 4-pin relays are interchangeable.

■NOTE: The module and wiring harness are not a serviceable component and must be replaced as an assembly.

1. Remove a fuse from the power distribution module.
2. Set the meter selector to the DC Voltage position.
3. Connect the black tester lead to ground.
4. Using the red tester lead, contact each end of the fuse holder connector terminals individually.

5. The meter must show battery voltage from one side of the connector terminal ends.

■NOTE: Battery voltage will be indicated from only one side of the fuse holder connector terminal; the other side will show no voltage.

■NOTE: When testing the HI fuse holder, the headlight OFF/HI/LO switch must be in the HI position; when testing the LIGHTS fuse holder, the headlight dimmer switch can be in either the HI or LO position.

■NOTE: If the meter shows no battery voltage, troubleshoot the battery, switches, power distribution module, or the main wiring harness.



2411-883

This vehicle uses automotive-style (see-through) fuses. The fuses can be visually inspected; replace fuse if link is open.

### CAUTION

Always replace a blown fuse with a fuse of the same type and rating.

■NOTE: Make sure the fuses are returned to their proper position according to amperage. Refer to the amperage listed under each fuse on the power distribution module.

---

---

## EFI Sensor/Components

---

### FUEL INJECTOR



Component data can be tested using the CATT II. Utilize the Test screen.

### Voltage

Remove the connector from the fuel injector. Place the red meter lead to the orange wire and black meter lead to ground. With the ignition switch in the on position the meter must read battery voltage.

### Resistance

With the connector still removed from the injector, place the red meter lead to either terminal; then connect the black tester lead to the other terminal. Reading is typically 12 ohms.

■NOTE: If voltage is not present, troubleshoot the battery, connector pins, wiring harness, fuses, or relay. If resistance is not present or largely out of specification, replace the injector.



EFI028

Display: % of TPS (0% closed, 95-100% WOT).

DTC: P0121, P0122, P0123

Usage: Verify TPS signal and adjust throttle cable.

### MAP (bArO) Diagnostic Mode



EFI027

Display: MAP in millibars (1013 millibars = 29.92 in. Hg).

DTC: P0107, P0108

Usage: Verify barometric pressure signal correct.

■**Note:** Local barometric pressure is given in in./Hg (Inches of Mercury). 34 millibars are equal to 1 inch of mercury. Example: (Gauge reading in the BARO mode = 974 millibars, thus  $974/34 = 28.64$  in./Hg). Second example: (Local barometer reading is 29.87 in./Hg, therefore  $29.87 \times 34 = 1015$  millibars). The gauge should be reading very close to 1015.

### IAT (AIr) Diagnostic Mode

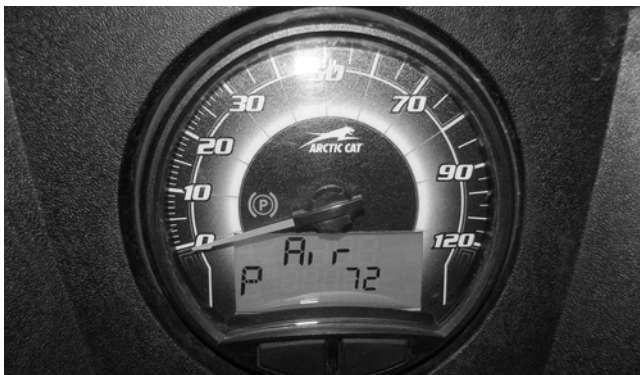

EFI026

Display: Inlet air temperature in Fahrenheit or Celsius.

DTC: P0112, P0113, P0114

Usage: Verify correct output of IAT sensor.

■**NOTE:** After engine has been running, IAT readings will be higher than outside air temperature due to engine and engine compartment heat as well as intake manifold heating.

### Battery (bAtt) Diagnostic Mode



EFI025

Display: System DC voltage.

DTC: P0562, P0563, P2531, P2532

Usage: Verify system voltage under following conditions.

1. Battery voltage with engine and accessories off (>12.2 VDC for fully charged).
2. Battery voltage with engine running (charging = 13.8 VDC or greater).
3. Battery voltage with electrical accessories operating, engine idling (13.5 VDC or greater).
4. Battery voltage starter cranking (10.5-11.5 VDC).

### DIAGNOSTIC TROUBLE CODES (DTC)

If an EFI or related chassis component fails or an out-of-tolerance signal is detected by the ECM, a diagnostic trouble code (DTC) will be generated in the ECM and displayed on the LCD. The DTC will continue to flash until the malfunction is corrected and the code cleared.

#### Code List

■**NOTE:** Each of the following numerical codes will have a one-letter prefix of C, P, or U. A “C” prefix denotes a chassis malfunction, a “P” prefix denotes a power train malfunction, and a “U” prefix denotes a loss of communication with the gauge.

■**NOTE:** Normal malfunction codes are cleared from the LCD when the component is replaced or the malfunction is corrected; however, intermittent codes must be cleared as noted in the code chart.

Code	Fault Description	Possible Cause	Fault Recovery
C0063	Tilt Sensor Circuit High	Sensor or interconnect harness shorted to battery power	Correct condition*

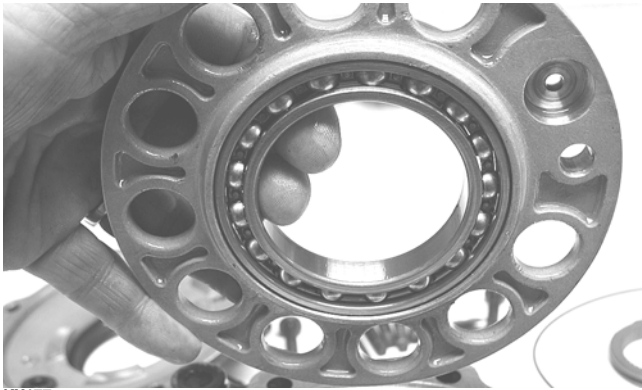

KX177

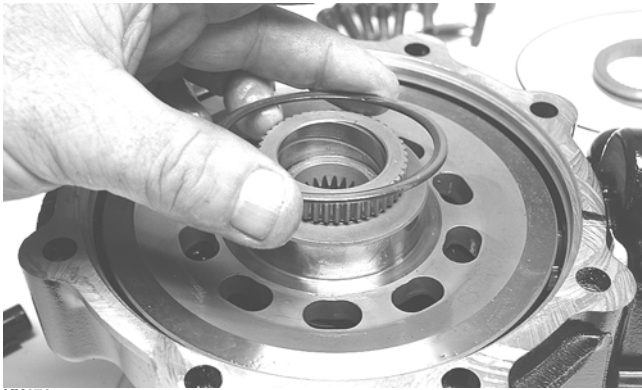

KX178

6. Place the differential with the open side down; then lift the housing off the spider assembly. Account for shim(s) and mark as right-side.



KX179

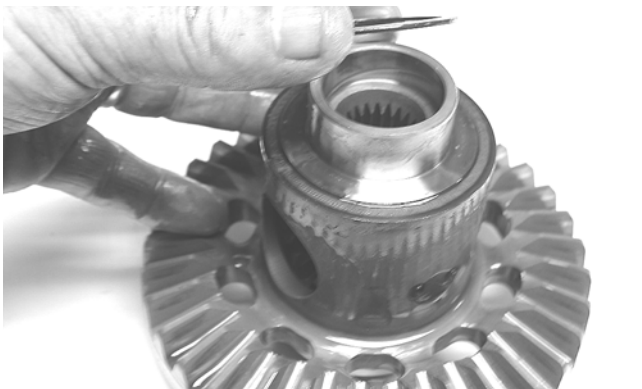

KX181

### Disassembling Pinion Gear

1. Remove the internal snap ring securing the pinion bearing in the housing.

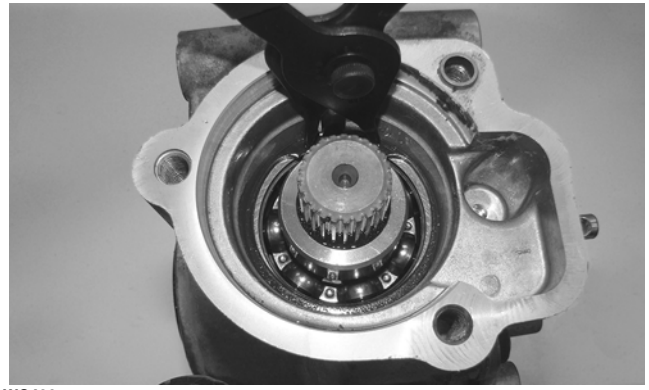

WC430

2. Using the Pinion Gear/Shaft Removal Tool and a hammer, remove the pinion gear from the gear case housing.

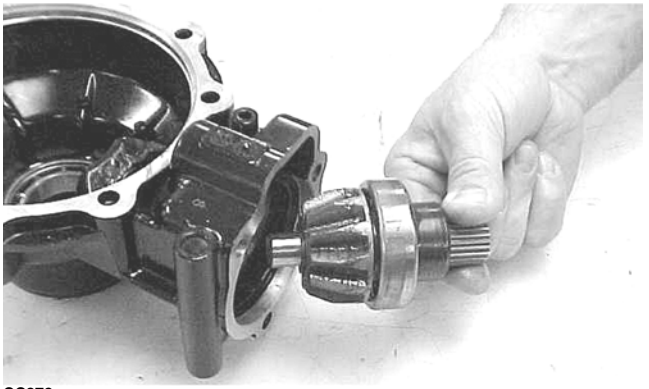

CC878

3. Secure the pinion gear in a bearing puller; then remove the pinion bearing using a press. Account for a collar and a bearing.

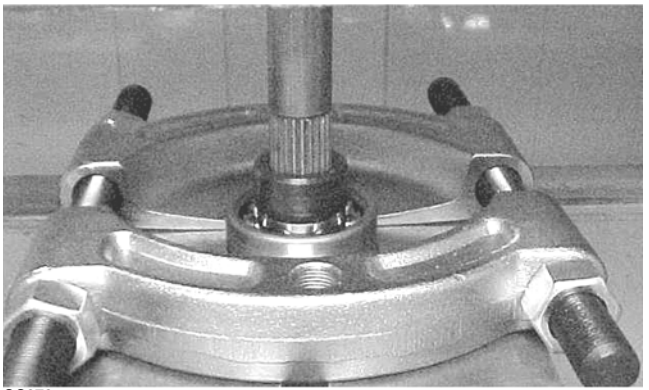

CC879

4. Remove any reusable parts from the gear case housing; then discard the housing and lock collar.

### Assembling Pinion Gear

1. Install the bearing onto the pinion shaft. Install the pinion shaft collar.

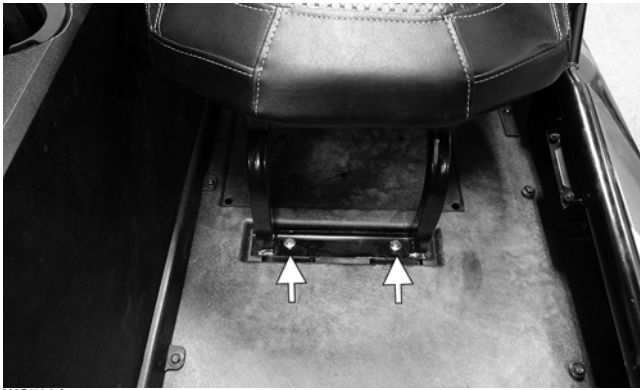

WC722A

9. Install the front seats.

---

## Drive Axles

---

### REMOVING REAR DRIVE AXLE

1. Secure the vehicle on a support stand to elevate the wheel; then remove the wheel and account for the hub plate.

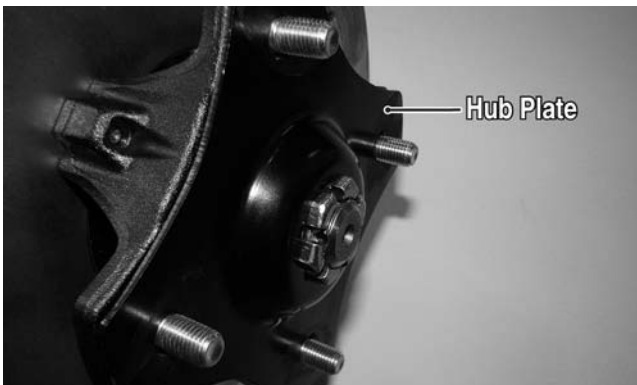

WC240B

2. Remove the Belleville washer and hub nut securing the hub.



WC304

3. Remove the brake caliper.

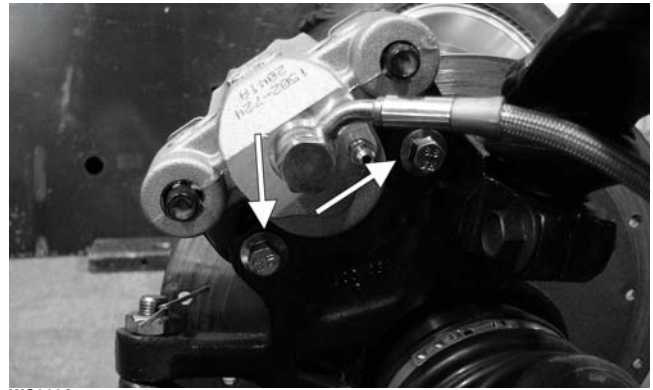

WC268A

4. Remove the hub assembly.

5. Leaving the lower trailing arm connected to the knuckle, remove the upper trailing arm and lateral links from the knuckle; then move the top of the knuckle outward and rotate forward to disengage the axle from the axle bearing.

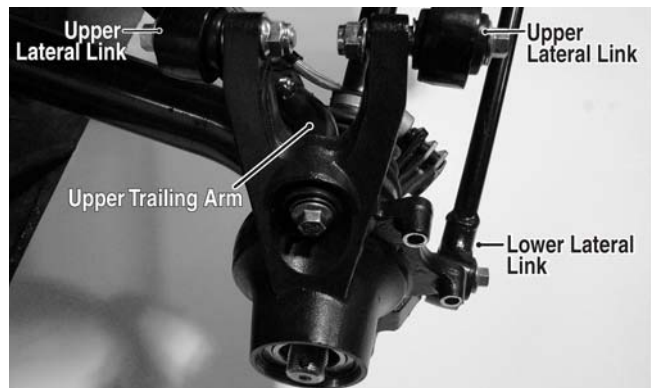

WC282B



WC286A

6. Remove the rear axles from the rear drive gear case by pushing the axle shaft toward the gear case and pulling the CV/spline shaft out. Account for one O-ring on each axle shaft.

## Hydraulic Brake Caliper

### **WARNING**

Arctic Cat recommends only authorized Arctic Cat Wildcat dealers perform hydraulic brake service. Failure to properly repair brake systems can result in loss of control causing severe injury or death.

### **REMOVING/DISASSEMBLING (Front)**

1. Secure the vehicle on a support stand to elevate the wheel; then remove the wheels of the brake to be serviced.

### **WARNING**

Never let brake fluid contact the eyes. Damage to the eyes will occur. Always wear appropriate protective safety goggles and latex gloves when handling brake fluid.

### **CAUTION**

Brake fluid is highly corrosive. Do not spill brake fluid on any surface of the vehicle and do not reuse brake fluid.

■NOTE: Whenever brake components are removed, disassembled, or repaired where brake fluid is exposed to air, drain all fluid and replace with new DOT 4 brake fluid from an unopened container. Brake fluid readily absorbs moisture from the air significantly lowering the boiling point. This increases the chance of vapor lock reducing braking power and increasing stopping distance.

2. Drain the brake fluid from the caliper, hose, and master cylinder through the bleed screw by pumping the brake pedal.
3. If the caliper is being removed, remove the E-clips on the inboard side of the caliper anchor bolts; then remove the anchor bolts from the knuckle.

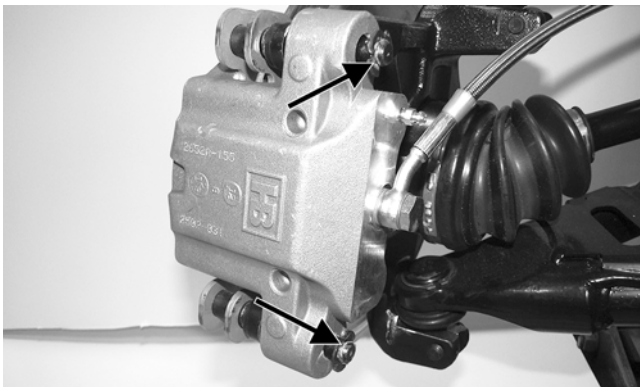

WC611A

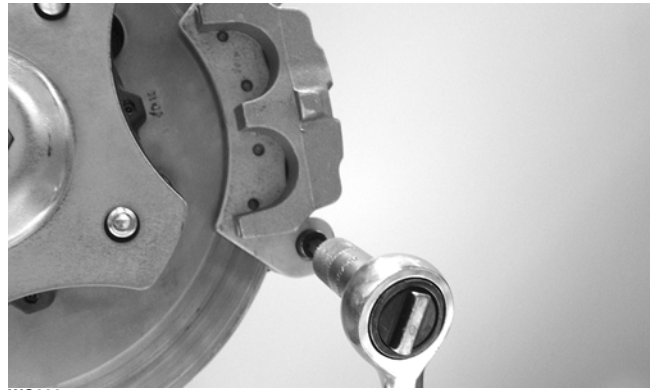

WC606

■NOTE: If brake pads are to be returned to service, do not allow brake fluid to contaminate them.

4. Remove the brake pads from the caliper.



WC694

5. Cover the piston end of the housing with cardboard or a shop towel; then keeping fingers clear of piston travel, apply compressed air to the fluid port to blow the piston free of the housing. Account for four seal rings in the housing.



WC941

### **WARNING**

Make sure to hold the caliper firmly in place or the piston could be ejected from the housing causing injury.

6. Using an appropriate seal removal tool, carefully remove the seals from the brake caliper housing; then remove four O-rings from the brake caliper housing noting the location of the different sized O-rings. Discard all seals, O-rings, and crush washers.

CLICK HERE TO **DOWNLOAD** THE COMPLETE MANUAL

- Thank you very much for reading the preview of the manual.
- You can download the complete manual from: [www.heydownloads.com](http://www.heydownloads.com) by clicking the link below



- Please note: If there is no response to CLICKING the link, please download this PDF first and then click on it.

CLICK HERE TO **DOWNLOAD** THE COMPLETE MANUAL