

2016

SERVICE MANUAL



150



CLICK HERE TO **DOWNLOAD** THE COMPLETE MANUAL

- Thank you very much for reading the preview of the manual.
- You can download the complete manual from: www.heydownloads.com by clicking the link below



- Please note: If there is no response to CLICKING the link, please download this PDF first and then click on it.

CLICK HERE TO **DOWNLOAD** THE COMPLETE MANUAL

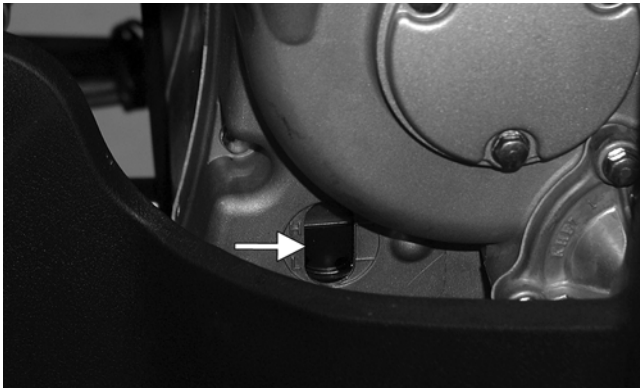

KM127A

9. Inspect the area around the screen/filter cap for leaks.

Transmission Lubricant

Change the lubricant according to the Periodic Maintenance Chart. When changing the lubricant, use approved SAE 80W-90 hypoid gear lube.

To change the lubricant, use the following procedure.

1. Place the ATV on level ground.
2. Loosen the fill plug; then remove the transmission drain plug and drain the transmission lubricant.

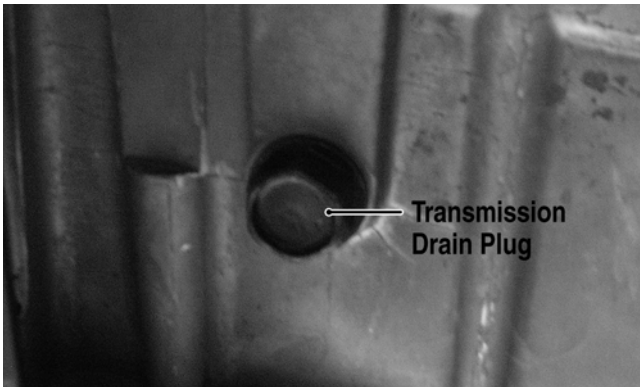

KM851A

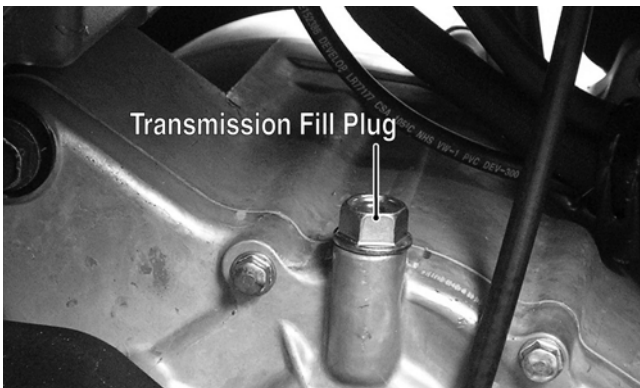

KM845A

3. Install the drain plug and tighten to 21 ft-lb; then remove the transmission level plug and the fill plug.

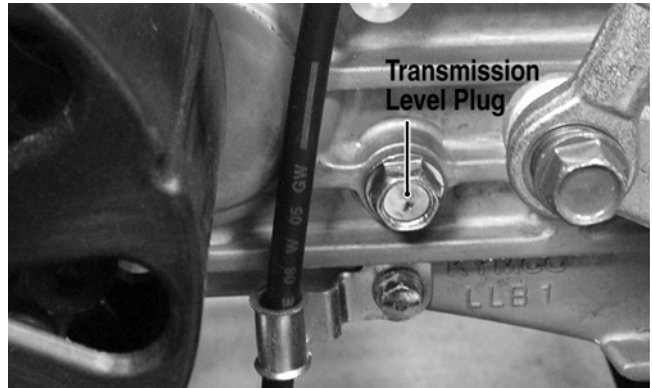

TR028A

4. Pour in the appropriate amount of recommended lubricant into the fill hole while observing the level hole. When correctly filled, transmission lubricant should just be visible on the bottom threads of the level hole.
5. Install the level plug and fill plug and tighten securely; then check for leakage around the drain plug.

Drive Chain

Drive chain condition and adjustment should be inspected each day before the ATV is operated. Always follow the following guidelines for inspecting and servicing the drive chain.

WARNING

Failure to inspect and maintain the drive chain can be hazardous. Operating the ATV with the drive chain in poor condition or improperly adjusted can cause an accident resulting in possible injury.

INSPECTING

Inspect the drive chain for any of the following conditions.

- A. Loose pins.
- B. Loose or cracked rollers.
- C. Dry or rusted links.
- D. Kinked or binding links.
- E. Excessive wear.

The presence of any of the conditions requires drive chain replacement.

■ **NOTE:** If the drive chain is worn or damaged, the sprockets may also be worn or damaged. Inspect the sprockets for worn, broken, or damaged teeth. Always inspect the sprockets when a new drive chain is being installed.

CLEANING AND LUBRICATING

The drive chain should be cleaned and lubricated frequently to prolong chain and sprocket life. Use the following procedure to clean and lubricate the chain.

- Adjust toe-in to 15 mm (0.60 in.); then measure distances (C) and (D). Distances (C) and (D) should be equal.
- After all the adjustments are to specifications, tighten the tie-rod lock nuts to 22 ft-lb.

■NOTE: Prior to locking the jam nuts, make sure the ball joints are at the center of their normal range of motion and at the correct angle.

■NOTE: The front wheels do not have to be removed to adjust the tie rod. Also, care should be taken not to disturb the handlebar position.

Front Brake Lever

WARNING

After removing and installing of components that are brake-related, ALWAYS check and adjust brakes as necessary before operating the ATV.

REMOVING

- Remove the right handlebar grip.
- Remove the cover from the throttle control housing exposing the throttle cable; then remove the cable.

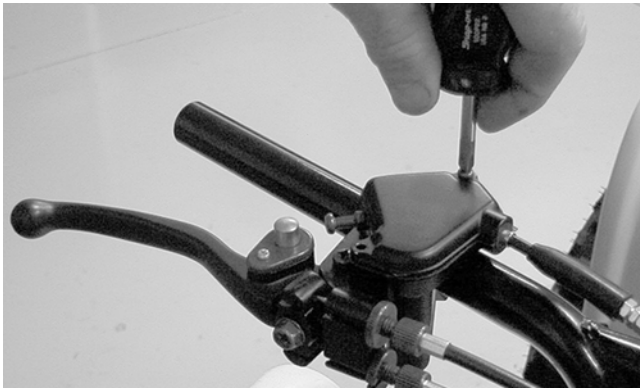

MD2440

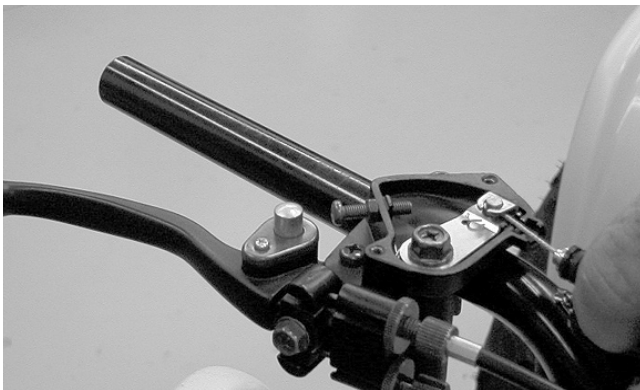

MD2439

- Remove the front brake cables from their adjusters by screwing the adjusters inward to loosen the cables; then pulling them free.

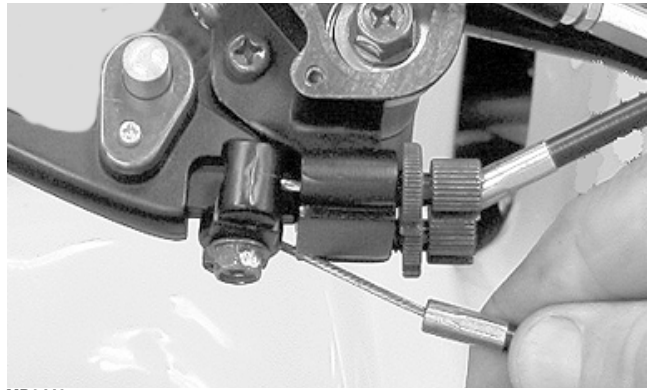

MD2449

- Loosen the screw securing the front brake lever assembly and slide the assembly off the handlebar.



MD2450

INSTALLING

- Slide the right brake lever assembly onto the handlebar; do not tighten the screw completely at this time.



MD2452

- Install the throttle cable into the throttle control housing; then install the cover and secure with the screws.



MD2454

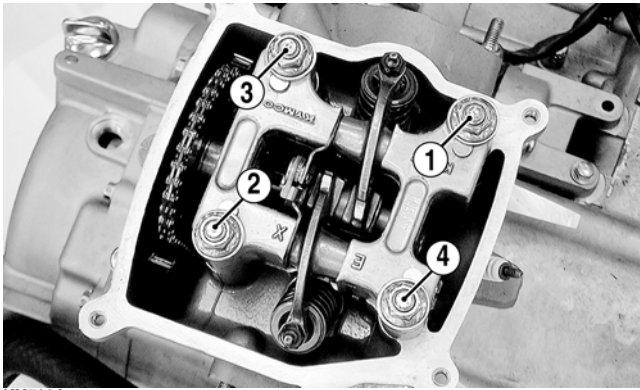

KM706A

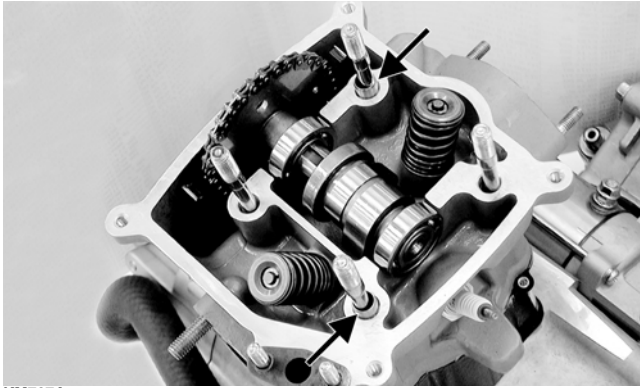

KM707A

4. Remove the camshaft gear from the cam chain; then secure the timing chain so it will not fall into the engine. Remove the camshaft.
5. Remove the two cap screws securing the cylinder head to the cylinder; then remove the cylinder head. Account for two alignment pins and a cylinder head gasket.

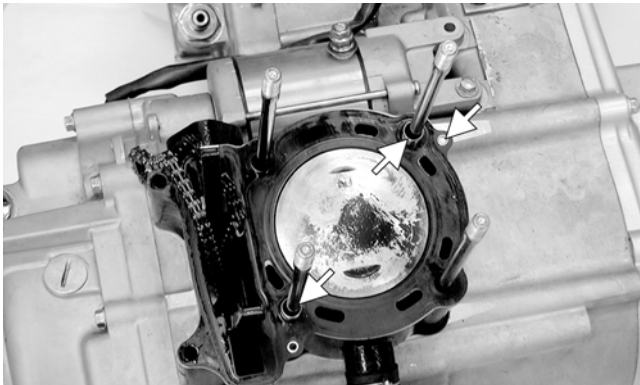

KM718A

6. Remove the cam chain guide; then remove the cylinder. Support the piston with rubber bands or other suitable supports. Account for two dowel pins and the cylinder gasket.

AT THIS POINT

To service valves and cylinder head, see Servicing Top-Side Components sub-section.

AT THIS POINT

To inspect cam chain guide, see Servicing Top-Side Components sub-section.

C. Cylinder

D. Piston

■NOTE: Steps 1-6 in the preceding sub-section must precede this procedure.

AT THIS POINT

To service cylinder, see Servicing Top-Side Components sub-section.

CAUTION

When removing the cylinder, be sure to support the piston to prevent damage to the crankcase and piston.

7. Using a needle nose pliers, remove one piston pin circlip. Take care not to drop it into the crankcase.



KM451

8. Using Piston Pin Puller, remove the piston pin. Account for the opposite-side circlip. Remove the piston.

■NOTE: It is advisable to remove the opposite-side circlip prior to using the puller.

■NOTE: Support the connecting rod with rubber bands to avoid damaging the rod or install a connecting rod holder.

CAUTION

Do not allow the connecting rod to go down inside the crankcase. If the rod is down inside the crankcase and the crankshaft is rotated, severe damage will result.

■NOTE: If the existing rings will not be replaced with new rings, note the location of each ring for proper installation. When replacing with new rings, replace as a complete set only. If the piston rings must be removed, remove them in this sequence.

- A. Starting with the top ring, slide one end of the ring out of the ring-groove.
- B. Remove each ring by working it toward the dome of the piston while rotating it out of the groove.

AT THIS POINT

To service piston, see Servicing Top-Side Components sub-section.

AT THIS POINT

To service center crankcase components only, proceed to Removing Left-Side Components.

6. Measure the fixed driven face hub outside diameter using a calipers. The minimum service limit is 33.94 mm.



KM378

7. Measure the thickness of the centrifugal clutch shoe lining. The minimum service limit for the lining is 2.0 mm.

■NOTE: If any shoe lining is below the service limit, the complete set must be replaced.

Assembling

1. Place the fixed face of the driven pulley on the pulley compressor base.

■NOTE: Make sure the spacer is on the base or damage to the fixed face will occur when the spring is compressed.

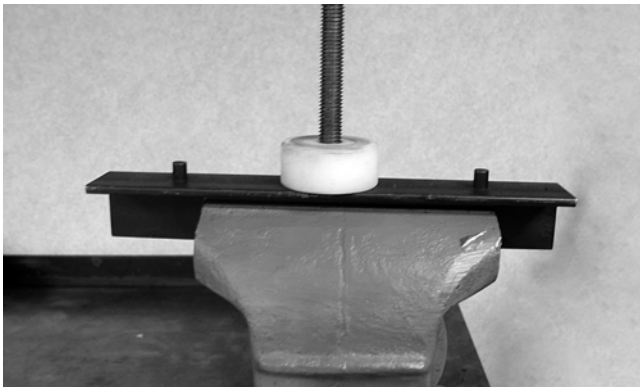

KX571

2. Apply multi-purpose grease to the O-rings and grease seals on the movable face; then install on the fixed face making sure the alignment marks are properly aligned.

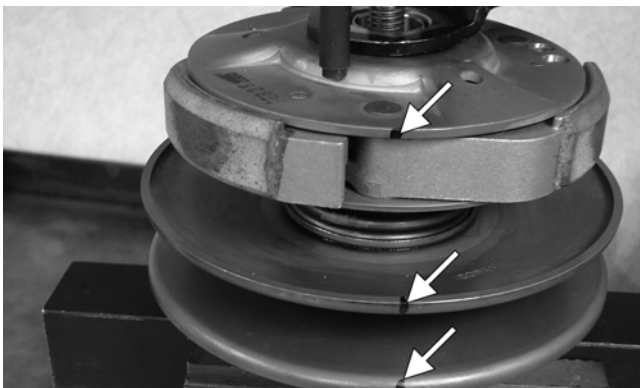

KM374A

3. Install the pins and spacers into the fixed face hub; then pack the cam slots in the movable face with multi-purpose grease.



KM384

4. Install the spring seat over the hub and movable face hub.



KM385

5. Place the spring holder on the spring; then install the spring on the pulley assembly.



KM386

6. Place the centrifugal clutch assembly, drive plate nut, and clutch compressor adapter in position; then using the clutch compressor wing nut, compress the clutch spring and install the nut (lightly coated with red Loctite #271).

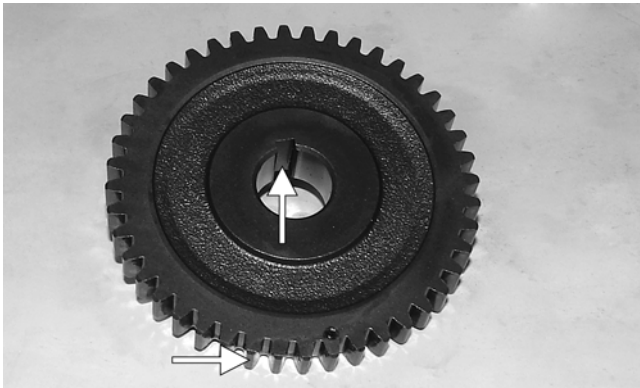

TR145A

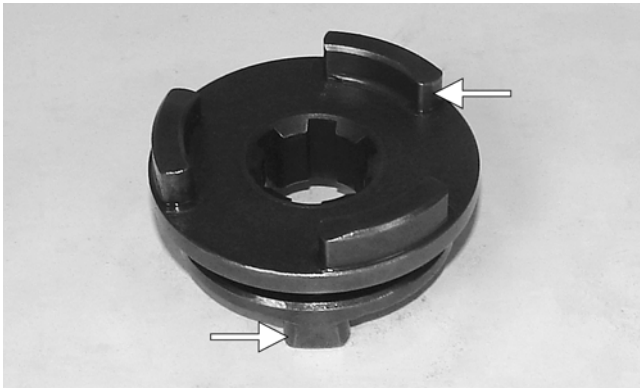

TR142A

2. Inspect the transmission shafts, bushings, and bearings for excessive wear or discoloration.
3. Check splines for excessive wear or twisting.

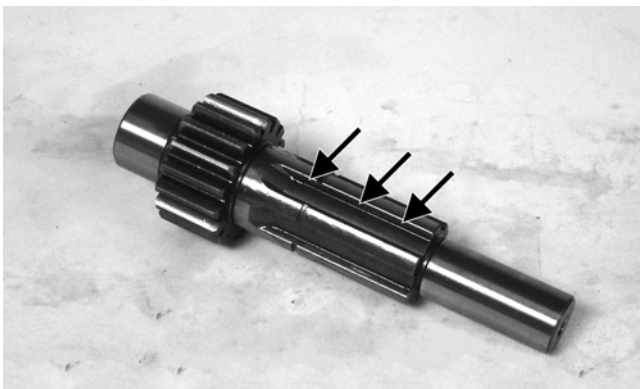

TR162A

4. Check shift fork for excessive wear or discoloration.



TR153

5. Check shift fork shaft for distortion. Maximum distortion (runout) must not exceed specifications.

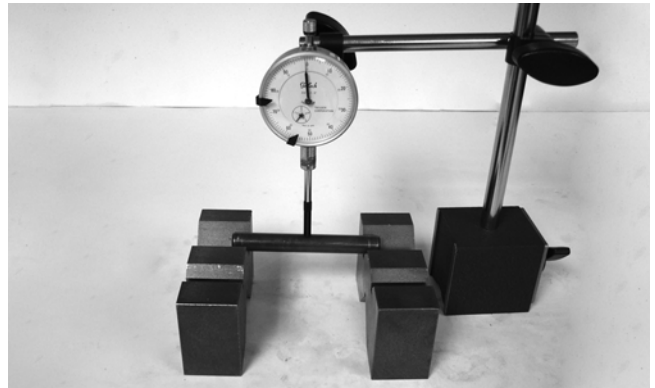

TR155

6. Inspect crankshaft bearings for smoothness of turning and any signs of discoloration.



TR160

7. Using V-blocks and a dial gauge, check crankshaft runout. Maximum runout must not exceed specifications.

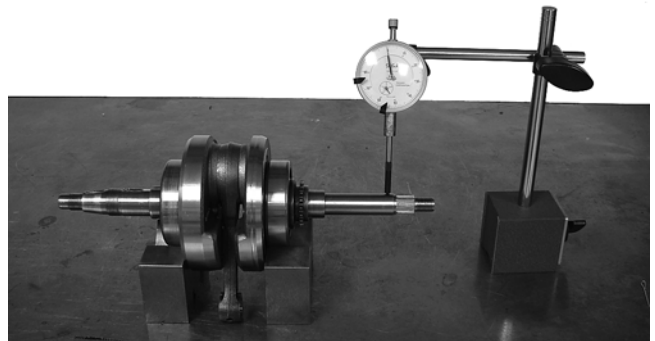

TR121

8. Check connecting rod small-end deflection. Maximum deflection must not exceed specifications.

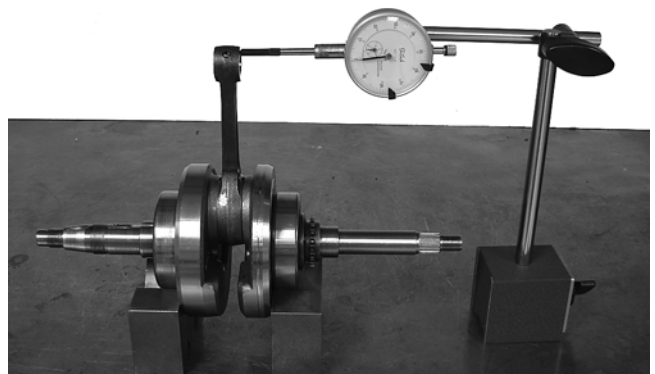

TR122



TR030

1. With the transmission in neutral, start the engine and warm it up to normal operating temperature.
2. Turn the idle adjustment screw clockwise one turn past the recommended RPM setting; then turn it counterclockwise to the correct setting of 1600-1800 RPM.

⚠ WARNING

Adjust the idle to the correct RPM. Make sure the engine is at normal operating temperature before adjusting the idle RPM.

Gas Tank

⚠ WARNING

Whenever any maintenance or inspection is made on the fuel system during which there may be fuel leakage, there should be no welding, smoking, open flames, etc., in the area.

REMOVING

1. Turn the gas tank valve to the OFF position.
2. Remove the seat.
3. Disconnect the hose from the carburetor to the gas tank at the carburetor; then remove the gas tank cover.
4. Remove the cap screws securing the gas tank to the frame.

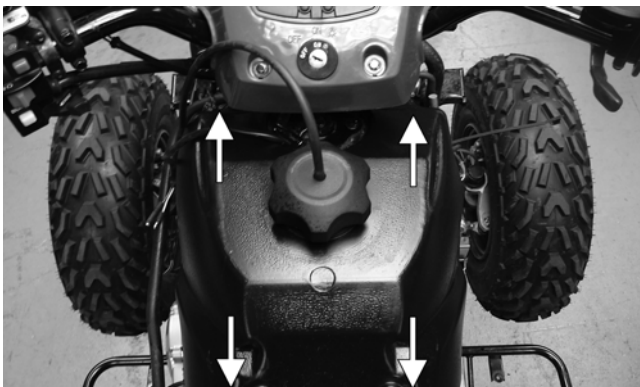

KM327A

5. Remove the vent hose; then remove the gas tank.

CLEANING AND INSPECTING

1. Clean all gas tank components with parts-cleaning solvent.
2. Inspect all hoses for cracks or leaks.
3. Inspect gas tank valve, tank cap, and tank for leaks, holes, and damaged threads.
4. Inspect the gas gauge for proper operation.

INSTALLING

1. Place the gas tank into position on the frame; then install the cap screws. Tighten securely.
2. Connect the gas hose from the carburetor.
3. Install the vent hose; then fill the gas tank with gasoline.
4. Turn the gas tank valve to the ON position and inspect for leakage.
5. Install the seat.

Gas Tank Valve

The ATV has a valve attached to the gas tank. There are three positions: ON, RES, and OFF.

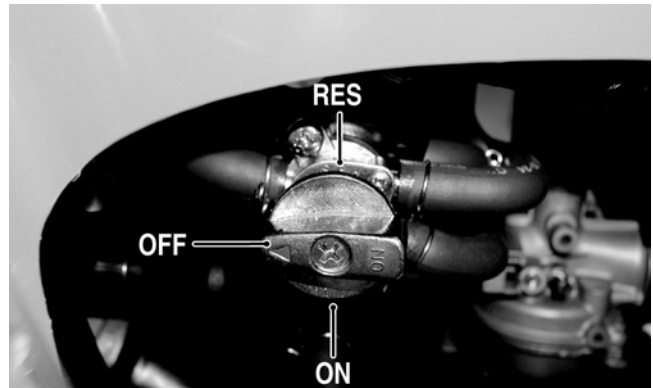

KM043A

In the OFF position, the valve will not allow gasoline to flow to the carburetor. In the ON position (the normal operating position), gasoline will flow from the tank to the carburetor. In this position 4.54 L (1.2 U.S. gal.) will remain in the tank as a reserve quantity. Moving the valve to the RES position will allow the operator to use the remaining gasoline in the tank. When turning the valve to any of the three positions, make sure the indicator is pointed directly at the position desired.

REMOVING/INSPECTING

⚠ WARNING

Drain the gas tank prior to this procedure.

1. Remove the gas hose from the valve by releasing the clamp.
2. Remove the two machine screws securing the valve; then remove the valve. Account for the gasket.
3. Inspect the gasket and valve/tank mating surfaces for damage or deterioration.
4. Inspect for and remove any obstructions in the valve.

1. Set the meter selector to the DC Voltage position.
2. Connect the red tester lead to the green wire; then connect the black tester lead to the white wire.
3. With the dimmer switch in the LO position (LO beam), the meter must show battery voltage.
4. Connect the red tester lead to the blue wire. With the dimmer switch in the HI position (HI beam), the meter must show battery voltage.

■NOTE: If battery voltage is not shown in any test, inspect the fuses, battery, main wiring harness, connectors, or the left handlebar switch.

VOLTAGE (Taillight)

The 3-prong connector is located under the rear fender assembly.

■NOTE: Perform this test on the main harness side of the connector. Also, the ignition switch should be in the LIGHTS position.

1. Set the meter selector to the DC Voltage position.

2. Connect the red tester lead to the brown wire; then connect the black tester lead to the green wire.
3. With the ignition key in the LIGHTS position, the meter must show battery voltage.

■NOTE: If the meter shows no voltage, inspect fuses, wiring harness, connectors, and switches.

VOLTAGE (Brakelight)

■NOTE: Perform this test on the main harness side of the connector. Also, the ignition switch should be in the ON position and the brake (either foot pedal or hand lever) must be applied.

1. Set the meter selector to the DC Voltage position.
2. Connect the red tester lead to the green/yellow wire; then connect the black tester lead to the green wire.
3. With either brake applied, the meter must show battery voltage.

■NOTE: If the meter shows no voltage, inspect fuses, wiring harness, connectors, and switches.

CLICK HERE TO **DOWNLOAD** THE COMPLETE MANUAL

- Thank you very much for reading the preview of the manual.
- You can download the complete manual from: www.heydownloads.com by clicking the link below



- Please note: If there is no response to CLICKING the link, please download this PDF first and then click on it.

CLICK HERE TO **DOWNLOAD** THE COMPLETE MANUAL