

CLICK HERE TO **DOWNLOAD** THE COMPLETE MANUAL

- Thank you very much for reading the preview of the manual.
- You can download the complete manual from: www.heydownloads.com by clicking the link below



- Please note: If there is no response to CLICKING the link, please download this PDF first and then click on it.

CLICK HERE TO **DOWNLOAD** THE COMPLETE MANUAL

BASE AUDIO

< WIRING DIAGRAM >

[BASE AUDIO]

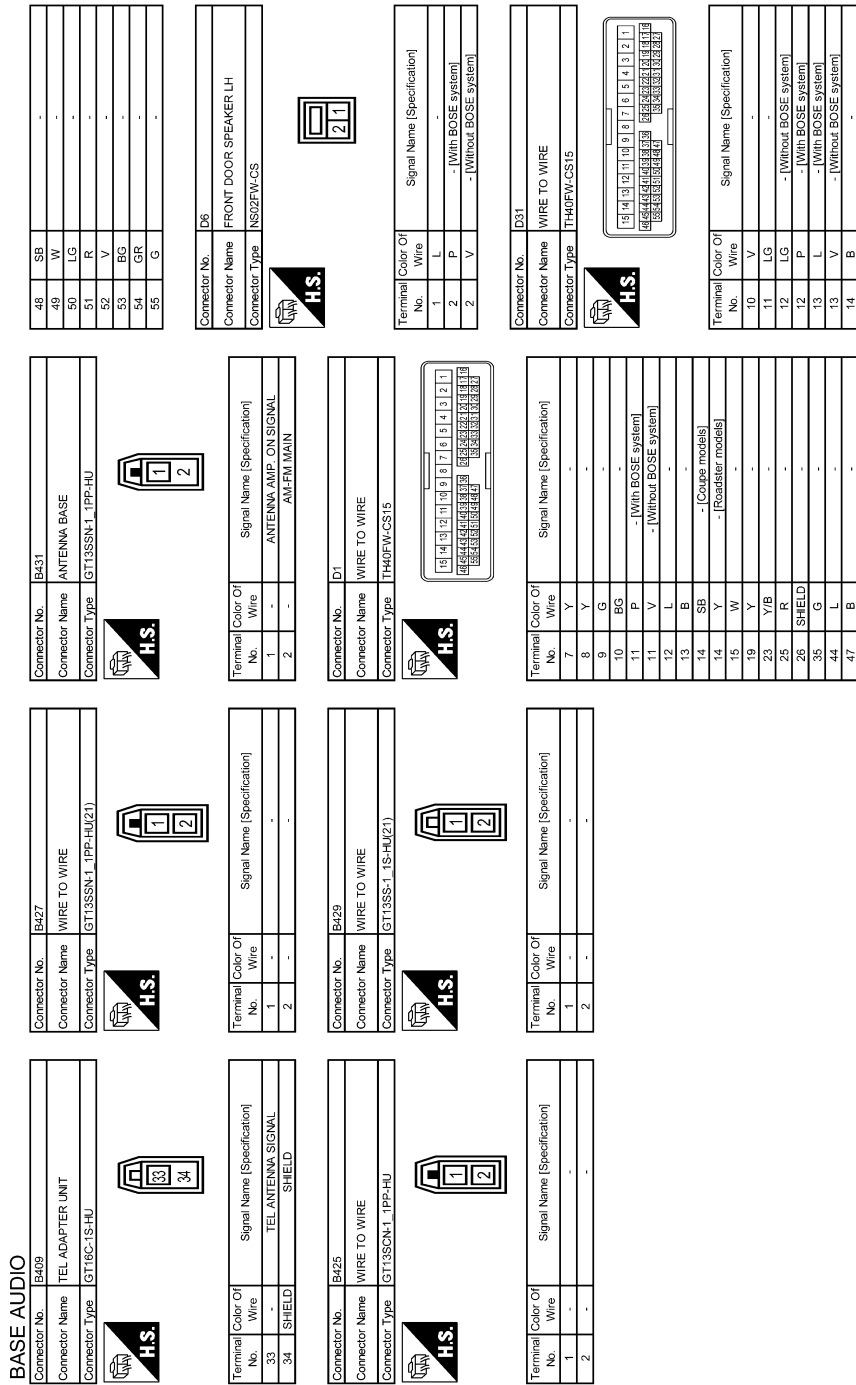

JRNWD6439GB

DIAGNOSIS SYSTEM (AV CONTROL UNIT)

< SYSTEM DESCRIPTION >

[BOSE AUDIO WITH NAVIGATION]

Error item	Description	Possible malfunction factor/Action to take
FRONT DISP CONN [U1243]	When either one of the following items are detected: <ul style="list-style-type: none"> • front display unit power supply and ground circuits malfunction is detected. • communication circuits between AV control unit and front display unit. 	<ul style="list-style-type: none"> • Front display unit power supply and ground circuits. • Communication circuits between AV control unit and AV front display unit.
GPS ANTENNA CONN [U1244]	GPS antenna connection malfunction is detected.	Check the connection of the GPS antenna connector.
XM ANTENNA CONN [U1258]	Satellite radio antenna connection malfunction is detected.	<ul style="list-style-type: none"> • Satellite radio antenna feeder. • Satellite radio antenna.
USB OVERCURRENT [U1263]	Detection of over current in USB connector.	Check USB harness between the AV control unit and USB connector.
ANTENNA AMP TERMINAL [U1264]	Radio antenna amp. ON signal circuit malfunction is detected.	Radio antenna amp. ON signal circuit between AV control unit and radio antenna amp.
AMP ON TERMINAL [U1265]	BOSE amp. ON signal circuit malfunction is detected.	BOSE amp. ON signal circuit between AV control unit and BOSE amp.
<ul style="list-style-type: none"> • AV COMM CIRCUIT [U1300] • SWITCH CONN [U1240] 	When either one of the following items are detected: <ul style="list-style-type: none"> • multifunction switch power supply and ground circuits are malfunctioning. • AV communication circuits between AV control unit and multifunction switch are malfunctioning. 	<ul style="list-style-type: none"> • Multifunction switch power supply and ground circuits. • AV communication circuits between AV control unit and multifunction switch.

DATA MONITOR

NOTE:

The following table includes information (items) inapplicable to this vehicle. For information (items) applicable to this vehicle, refer to CONSULT display items.

ALL SIGNALS

- Displays the status of the following vehicle signals inputted into the AV control unit.
- For each signal, actual signal can be compared with the condition recognized on the system.

Display Item	Display	Vehicle status	Remarks
VHCL SPD SIG	On	Vehicle speed >0 km/h (0 MPH)	Changes in indication may be delayed. This is normal.
	Off	Vehicle speed =0 km/h (0 MPH)	
PKB SIG	On	Parking brake is applied.	
	Off	Parking brake is released.	
ILLUM SIG	On	Block the light beam from the auto light optical sensor when the light SW is ON.	—
	Off	Expose the auto light optical sensor to light when the light SW is OFF or ON.	
IGN SIG	On	Ignition switch ON	
	Off	Ignition switch in ACC position	
REV SIG	On	Selector lever in R position	Changes in indication may be delayed. This is normal.
	Off	Selector lever in any position other than R	
SIDE VIEW SW	Off	This item is displayed, but cannot be monitored.	—
ROOM LAMP	Off	This item is displayed, but not used.	—

SELECTION FROM MENU

U1225 AV CONTROL UNIT

< DTC/CIRCUIT DIAGNOSIS >

[BOSE AUDIO WITH NAVIGATION]

U1225 AV CONTROL UNIT

DTC Logic

INFOID:000000010837142

DTC DETECTION LOGIC

DTC	Display contents of CONSULT	DTC detection condition	Possible malfunction factor
U1225	USB CONTROLLER [U1225]	USB connection malfunction is detected.	Check that the connection to the USB connector is normal.

ANTENNA BASE

< REMOVAL AND INSTALLATION >

[BOSE AUDIO WITH NAVIGATION]

ANTENNA BASE

Exploded View

INFOID:0000000010837211

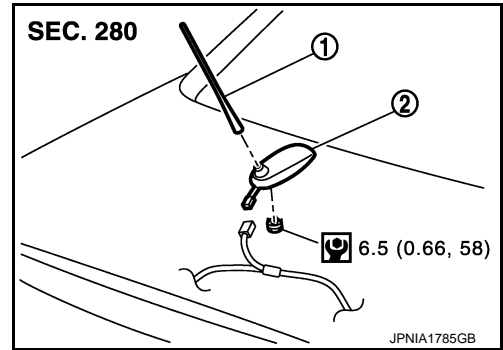

1. Antenna rod
2. Antenna base

Refer to [GI-4, "Components"](#) for symbols in the figure.

Removal and Installation

INFOID:0000000010837212

REMOVAL

1. Remove trunk lid finisher inner. Refer to [INT-79, "Exploded View"](#).
2. Remove antenna base mounting nut, disconnect the antenna base connector.
3. Remove antenna base.

INSTALLATION

Installation is the reverse order of removal.

CAUTION:

Be careful about tightening torque. Antenna sensitivity becomes poor, and when it is excessive, trunk lid panel may be deformed, when antenna base mounting nut tightening torque is loose.

DIAGNOSIS SYSTEM (BCM)

< SYSTEM DESCRIPTION >

Monitor item [Unit]	Description
KEY SW-SLOT [On/Off]	Key switch status input from key slot
UNLK SEN-DR [On/Off]	Driver door unlock status input from unlock sensor
DOOR SW-DR [On/Off]	The switch status input driver side front door switch
DOOR SW-AS [On/Off]	The switch status input from passenger side door switch
DOOR SW-RR [On/Off]	NOTE: The item is indicated, but not monitored.
DOOR SW-RL [On/Off]	
DOOR SW-BK [On/Off]	The switch status input from trunk room lamp switch
CDL LOCK SW [On/Off]	Lock switch status received from the door lock and unlock switch
CDL UNLOCK SW [On/Off]	Unlock switch status received from the door lock and unlock switch
KEY CYL LK-SW [On/Off]	Lock switch status received from key cylinder switch
KEY CYL UN-SW [On/Off]	Unlock switch status received from key cylinder switch
TRNK/HAT MNTR [On/Off]	NOTE: The item is indicated, but not monitored.
RKE-LOCK [On/Off]	Lock signal status received from remote keyless entry receiver
RKE-UNLOCK [On/Off]	Unlock signal status received from remote keyless entry receiver

ACTIVE TEST

Test item	Operation	Description
BATTERY SAVER	Off	Cuts the interior room lamp power supply to turn interior room lamp OFF.
	On	Outputs the interior room lamp power supply to turn interior room lamp ON.*

*: Each lamp switch is in ON position.

TRUNK

TRUNK : CONSULT Function (BCM - TRUNK) (For Coupe)

INFOID:000000011318891

DATA MONITOR

NOTE:

The following table includes information (items) inapplicable to this vehicle. For information (items) applicable to this vehicle, refer to CONSULT display items.

Monitor Item	Contents
PUSH SW	Indicates [On/Off] condition of push-button ignition switch
UNLK SEN -DR	Indicates [On/Off] condition of driver door UNLOCK status
VEH SPEED 1	Indicates [km/h] condition of vehicle speed signal from combination meter
KEY CYL SW-TR	NOTE: This item is displayed, but cannot be monitored
TR CANCEL SW*1	Indicates [On/Off] condition of trunk lid cancel switch

COMBINATION SWITCH SYSTEM SYMPTOMS

< SYMPTOM DIAGNOSIS >

SYMPTOM DIAGNOSIS

COMBINATION SWITCH SYSTEM SYMPTOMS

Symptom Table

INFOID:000000010837724

1. Perform "Data Monitor" of CONSULT to check for any malfunctioning item.
2. Check the malfunction combinations.

Malfunction item: ×

Malfunction combination	Data monitor item													
	FR WIPER HI	FR WIPER LOW	FR WASHER SW	FR WIPER INT	INT VOLUME	TURN SIGNAL R	TURN SIGNAL L	TAIL LAMP SW	HI BEAM SW	HEAD LAMP SW 1	HEAD LAMP SW 2	PASSING SW	AUTO LIGHT SW	RR FOG SW
A		×	×			×	×							
B	×			×						×		×		
C					×				×		×			
D					×			×					×	
E					×									×
F	×				×									
G			×		×									
H		×		×									×	×
I							×				×	×		
J						×		×	×	×				
K	All Items													
L	If only one item is detected or the item is not applicable to the combinations A to K													

3. Identify the malfunctioning part from the agreed combination and repair or replace the part.

Malfunction combination	Malfunctioning part	Repair or replace
A	Combination switch INPUT 1 circuit	Inspect the combination switch input circuit applicable to the malfunctioning part. Refer to BCS-54, "Diagnosis Procedure" .
B	Combination switch INPUT 2 circuit	
C	Combination switch INPUT 3 circuit	
D	Combination switch INPUT 4 circuit	
E	Combination switch INPUT 5 circuit	
F	Combination switch OUTPUT 1 circuit	Inspect the combination switch output circuit applicable to the malfunctioning part. Refer to BCS-56, "Diagnosis Procedure" .
G	Combination switch OUTPUT 2 circuit	
H	Combination switch OUTPUT 3 circuit	
I	Combination switch OUTPUT 4 circuit	
J	Combination switch OUTPUT 5 circuit	
K	BCM	Replace BCM. Refer to BCS-106, "Exploded View" .
L	Combination switch	Replace the combination switch.

FRONT DISC BRAKE

< REMOVAL AND INSTALLATION >

Check the surface of the piston for rust, wear, cracks or damage. Replace the piston if any abnormal condition is detected.

CAUTION:

A piston sliding surface is plated. Never polish with sandpaper.

INSPECTION AFTER INSTALLATION

1. Check a drag of front disc brake. If any drag is found, follow the procedure described below.

2. Remove brake pads. Refer to [BR-43, "BRAKE PAD \(4 PISTON TYPE\) : Exploded View"](#).

3. Press the pistons.

CAUTION:

- **Never damage the piston boot.**

- **When replacing a pad with new one, check a brake fluid level in the reservoir tank because brake fluid returns to master cylinder reservoir tank when pressing piston in.**

NOTE:

Use a disc brake piston tool to easily press piston.

4. Install brake pads. Refer to [BR-43, "BRAKE PAD \(4 PISTON TYPE\) : Exploded View"](#).

5. Depress the brake pedal several times.

6. Check a drag of front disc brake again. If any drag is found, disassemble the caliper. Refer to [BR-51, "BRAKE CALIPER ASSEMBLY \(4 PISTON TYPE\) : Disassembly and Assembly"](#).

7. Burnish contact surface between disc rotor and brake pads after refinishing or replacing disc rotor, or if a soft pedal occurs at very low mileage. Refer to [BR-16, "DISC ROTOR : Inspection and Adjustment"](#).

A
B
C
D
E
BR
G
H
I
J
K
L
M
N
O
P

C1115 WHEEL SENSOR

[VDC/TCS/ABS]

< DTC/CIRCUIT DIAGNOSIS >

Is the inspection result normal?

YES >> GO TO 11.

NO >> Repair or replace error-detected parts, securely lock the harness connector, and GO TO 9.

9. CHECK DATA MONITOR (2)

1. Erase self-diagnosis result for "ABS" with CONSULT.
2. Turn the ignition switch OFF, and wait 10 seconds or more.
3. Start the engine.
4. Select "ABS" and "DATA MONITOR", check the "FR LH SENSOR", "FR RH SENSOR", "RR LH SENSOR" and "RR RH SENSOR" with CONSULT.

NOTE:

Set the "DATA MONITOR" recording speed to "10 msec".

5. Read a value (wheel speed) of both normal wheel sensors and error-detecting wheel sensor.

Regarding the difference at 30 km/h (19 MPH) between the wheel speed detected by the error detecting wheel sensor and the maximum/minimum wheel speed detected by the normal wheel sensors, is the difference within 5%, respectively?

YES >> GO TO 10.

NO >> GO TO 11.

10. PERFORM SELF-DIAGNOSIS (3)

1. Drive the vehicle at approx. 30 km/h (19 MPH) or more for approx. 1 minute.
2. Stop the vehicle.
3. Perform self-diagnosis for "ABS" with CONSULT.

Is DTC "C1115" detected?

YES >> GO TO 11.

NO >> INSPECTION END

11. CHECK TERMINAL

1. Turn the ignition switch OFF.
2. Disconnect ABS actuator and electric unit (control unit) harness connector and then check the ABS actuator and electric unit (control unit) pin terminals for damage or loose connection with harness connector.
3. Disconnect wheel sensor harness connector and check the each wheel sensor pin terminals for damage or loose connection with harness connector.

Is the inspection result normal?

YES >> GO TO 14.

NO >> Repair or replace error-detected parts and GO TO 12.

12. CHECK DATA MONITOR (3)

1. Connect ABS actuator and electric unit (control unit) harness connector.
2. Connect wheel sensor harness connector.
3. Erase self-diagnosis result for "ABS" with CONSULT.
4. Turn the ignition switch OFF, and wait 10 seconds or more.
5. Start the engine.
6. Select "ABS" and "DATA MONITOR", check the "FR LH SENSOR", "FR RH SENSOR", "RR LH SENSOR" and "RR RH SENSOR" with CONSULT.

NOTE:

Set the "DATA MONITOR" recording speed to "10 msec".

7. Read a value (wheel speed) of both normal wheel sensors and error-detecting wheel sensor.

Regarding the difference at 30 km/h (19 MPH) between the wheel speed detected by the error detecting wheel sensor and the maximum/minimum wheel speed detected by the normal wheel sensors, is the difference within 5%, respectively?

YES >> GO TO 13.

NO >> GO TO 14.

13. PERFORM SELF-DIAGNOSIS (4)

1. Drive the vehicle at approx. 30 km/h (19 MPH) or more for approx. 1 minute.
2. Stop the vehicle.
3. Perform self-diagnosis for "ABS" with CONSULT.

Is DTC "C1115" detected?

PEDAL VIBRATION OR ABS OPERATION SOUND OCCURS

< SYMPTOM DIAGNOSIS >

[VDC/TCS/ABS]

PEDAL VIBRATION OR ABS OPERATION SOUND OCCURS

Diagnosis Procedure

INFOID:000000010840197

CAUTION:

Under the following conditions, ABS is activated and vibration is felt when brake pedal is lightly depressed (just place a foot on it). However, this is normal.

- When shifting gears
- When driving on slippery road
- During cornering at high speed
- When passing over bumps or grooves [at approximately 50 mm (1.97 in) or more]
- When pulling away just after starting engine [at approximately 10 km/h (6 MPH) or higher]

1. SYMPTOM CHECK 1

Check that there are pedal vibrations when the engine is started.

Do vibrations occur?

YES >> GO TO 2.

NO >> Inspect the brake pedal.

2. SYMPTOM CHECK 2

Check that there are ABS operation noises when the engine is started.

Do the operation noises occur?

YES >> GO TO 3.

NO >> Perform self-diagnosis for "ABS" with CONSULT.

3. SYMPTOM CHECK 3

Check symptoms when electrical component (headlamps, etc.) switches are operated.

Do symptoms occur?

YES >> Check if there is a radio, antenna, antenna lead wire, or wiring close to the control unit. If there is, move it farther away.

NO >> Normal

A
B
C
D
E
F
G
H
I
J
K
L
M
N
O
P

BRC

REPLACEMENT OPERATIONS

< REMOVAL AND INSTALLATION >

[TYPE 1]

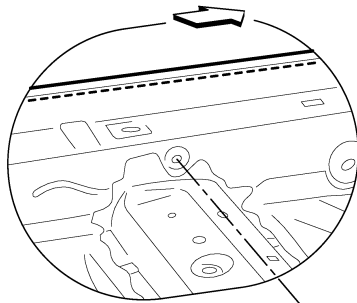
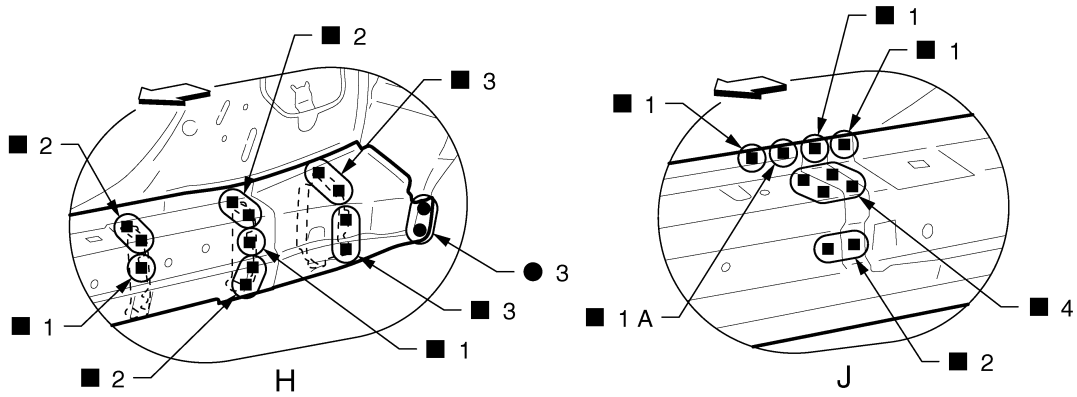

11 (1.1, 8)

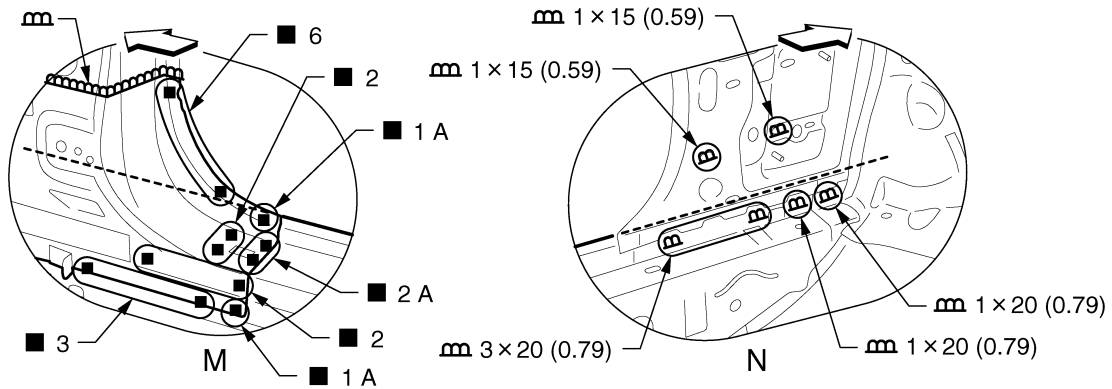

JSKIA0922GB

Unit: mm (in)

↔: Vehicle front

Refer to [GI-4, "Components"](#) for symbols in the figure.

View H: Before installing outer sill reinforcement

CHARGING SYSTEM

< DTC/CIRCUIT DIAGNOSIS >

CHARGING SYSTEM

Wiring Diagram - CHARGING SYSTEM -

INFOID:000000010840677

CHARGING SYSTEM

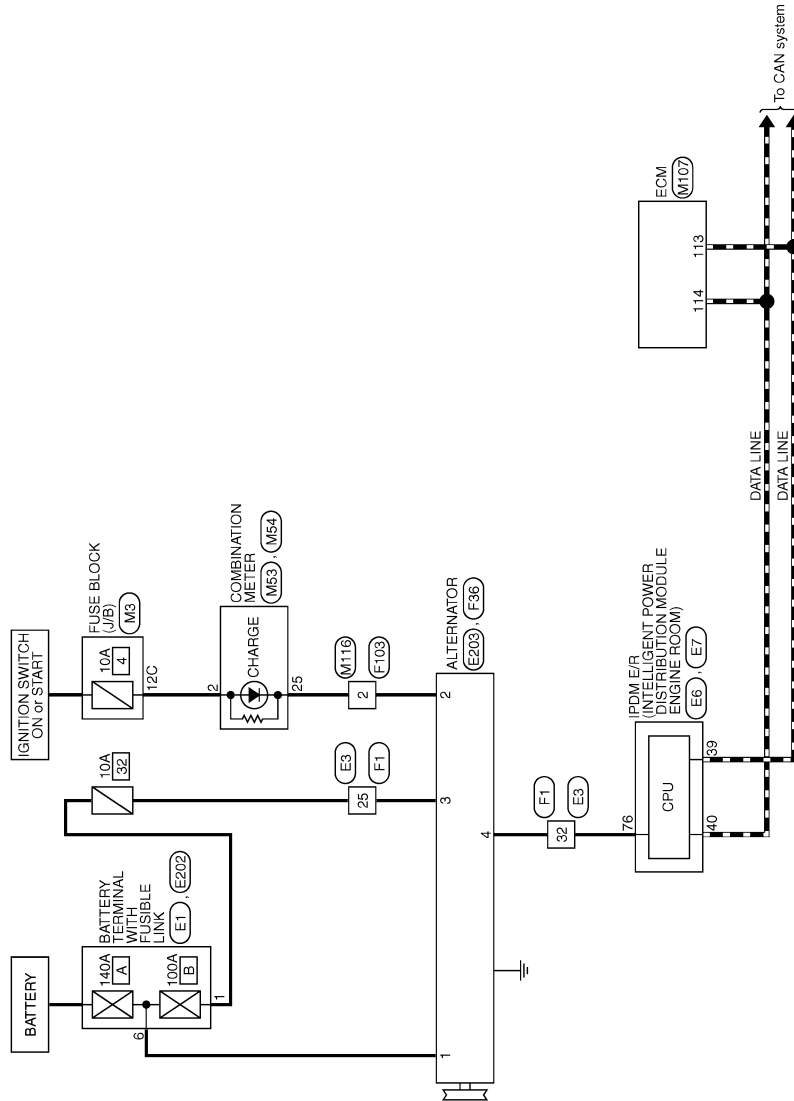

2009/07/10

JCMWM4775GB

A
B
C
D
E
F
G
H
I
J
K
L
N
O
P

CHG

RADIATOR

< PERIODIC MAINTENANCE >

- Use compressed air lower than 490 kPa (5 kg/cm², 71 psi) and keep distance more than 30 cm (11.8 in).
5. Blow air again into all the radiator core surfaces once per minute until no water sprays out.

BCM (BODY CONTROL MODULE)

< ECU DIAGNOSIS INFORMATION >

[COUPE]

Monitor Item	Condition	Value/Status	
CONFIRM ID ALL	The key ID that the key slot receives is not recognized by any key ID registered to BCM.	Yet	A
	The key ID that the key slot receives is recognized by any key ID registered to BCM.	Done	B
CONFIRM ID4	The key ID that the key slot receives is not recognized by the fourth key ID registered to BCM.	Yet	C
	The key ID that the key slot receives is recognized by the fourth key ID registered to BCM.	Done	D
CONFIRM ID3	The key ID that the key slot receives is not recognized by the third key ID registered to BCM.	Yet	E
	The key ID that the key slot receives is recognized by the third key ID registered to BCM.	Done	F
CONFIRM ID2	The key ID that the key slot receives is not recognized by the second key ID registered to BCM.	Yet	G
	The key ID that the key slot receives is recognized by the second key ID registered to BCM.	Done	H
CONFIRM ID1	The key ID that the key slot receives is not recognized by the first key ID registered to BCM.	Yet	I
	The key ID that the key slot receives is recognized by the first key ID registered to BCM.	Done	J
TP 4	The ID of fourth Intelligent Key is not registered to BCM	Yet	K
	The ID of fourth Intelligent Key is registered to BCM	Done	L
TP 3	The ID of third Intelligent Key is not registered to BCM	Yet	M
	The ID of third Intelligent Key is registered to BCM	Done	N
TP 2	The ID of second Intelligent Key is not registered to BCM	Yet	O
	The ID of second Intelligent Key is registered to BCM	Done	P
TP 1	The ID of first Intelligent Key is not registered to BCM	Yet	Q
	The ID of first Intelligent Key is registered to BCM	Done	R
AIR PRESS FL	Ignition switch ON (Only when the signal from the transmitter is received)	Air pressure of front LH tire	S
AIR PRESS FR	Ignition switch ON (Only when the signal from the transmitter is received)	Air pressure of front RH tire	T
AIR PRESS RR	Ignition switch ON (Only when the signal from the transmitter is received)	Air pressure of rear RH tire	U
AIR PRESS RL	Ignition switch ON (Only when the signal from the transmitter is received)	Air pressure of rear LH tire	V
ID REGST FL1	ID of front LH tire transmitter is registered	Done	W
	ID of front LH tire transmitter is not registered	Yet	X
ID REGST FR1	ID of front RH tire transmitter is registered	Done	Y
	ID of front RH tire transmitter is not registered	Yet	Z
ID REGST RR1	ID of rear RH tire transmitter is registered	Done	AA
	ID of rear RH tire transmitter is not registered	Yet	AB
ID REGST RL1	ID of rear LH tire transmitter is registered	Done	AC
	ID of rear LH tire transmitter is not registered	Yet	AD
WARNING LAMP	Tire pressure indicator OFF	Off	AE
	Tire pressure indicator ON	On	AF
BUZZER	Tire pressure warning alarm is not sounding	Off	AG
	Tire pressure warning alarm is sounding	On	AH

DIAGNOSIS SYSTEM (BCM)

< SYSTEM DESCRIPTION >

[ROADSTER]

DIAGNOSIS SYSTEM (BCM)

COMMON ITEM

COMMON ITEM : CONSULT Function (BCM - COMMON ITEM)

INFOID:000000011345918

APPLICATION ITEM

CONSULT performs the following functions via CAN communication with BCM.

Diagnosis mode	Function Description
Work Support	Changes the setting for each system function.
Self Diagnostic Result	Displays the diagnosis results judged by BCM.
CAN Diag Support Monitor	Monitors the reception status of CAN communication viewed from BCM.
Data Monitor	The BCM input/output signals are displayed.
Active Test	The signals used to activate each device are forcibly supplied from BCM.
Ecu Identification	The BCM part number is displayed.
Configuration	<ul style="list-style-type: none"> Read and save the vehicle specification. Write the vehicle specification when replacing BCM.

SYSTEM APPLICATION

BCM can perform the following functions for each system.

NOTE:

It can perform the diagnosis modes except the following for all sub system selection items.

×: Applicable item

System	Sub system selection item	Diagnosis mode		
		Work Support	Data Monitor	Active Test
Door lock	DOOR LOCK	×	×	×
Rear window defogger	REAR DEFOGGER		×	×
Warning chime	BUZZER		×	×
Interior room lamp timer	INT LAMP	×	×	×
Exterior lamp	HEAD LAMP	×	×	×
Wiper and washer	WIPER	×	×	×
Turn signal and hazard warning lamps	FLASHER	×	×	×
—	AIR CONDITONER*			
<ul style="list-style-type: none"> Intelligent Key system Engine start system 	INTELLIGENT KEY	×	×	×
Combination switch	COMB SW		×	
Body control system	BCM	×		
NVIS - NATS	IMMU		×	×
Interior room lamp battery saver	BATTERY SAVER	×	×	×
Back door/Trunk lid open	TRUNK		×	×
Vehicle security system	THEFT ALM	×	×	×
RAP system	RETAINED PWR		×	
Signal buffer system	SIGNAL BUFFER		×	×
TPMS	TPMS (AIR PRESSURE MONITOR)	×	×	×

NOTE:

*: This item is displayed, but is not used.

FREEZE FRAME DATA (FFD)

The BCM records the following vehicle condition at the time a particular DTC is detected, and displays on CONSULT.

BCM (BODY CONTROL MODULE)

< ECU DIAGNOSIS INFORMATION >

[ROADSTER]

- : With A/T
- : With M/T
- : With rear fog lamp
- : With side turn signal lamp

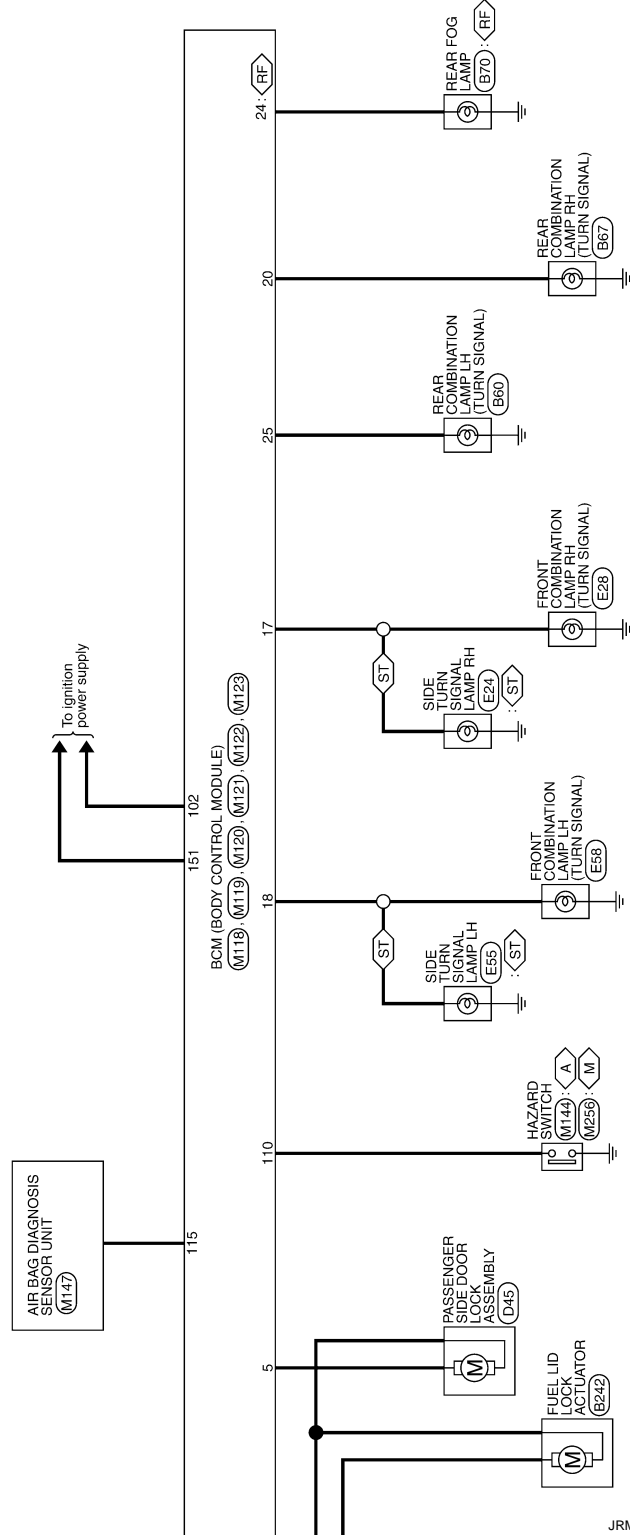

JRMWF7316GB

A
B
C
D
E
F
G
H
I
J
K
DEF
M
N
O
P

COMPONENT PARTS

< SYSTEM DESCRIPTION >

[COUPE]

BACK DOOR OPENER SYSTEM : Component Parts Location

INFOID:0000000110840789

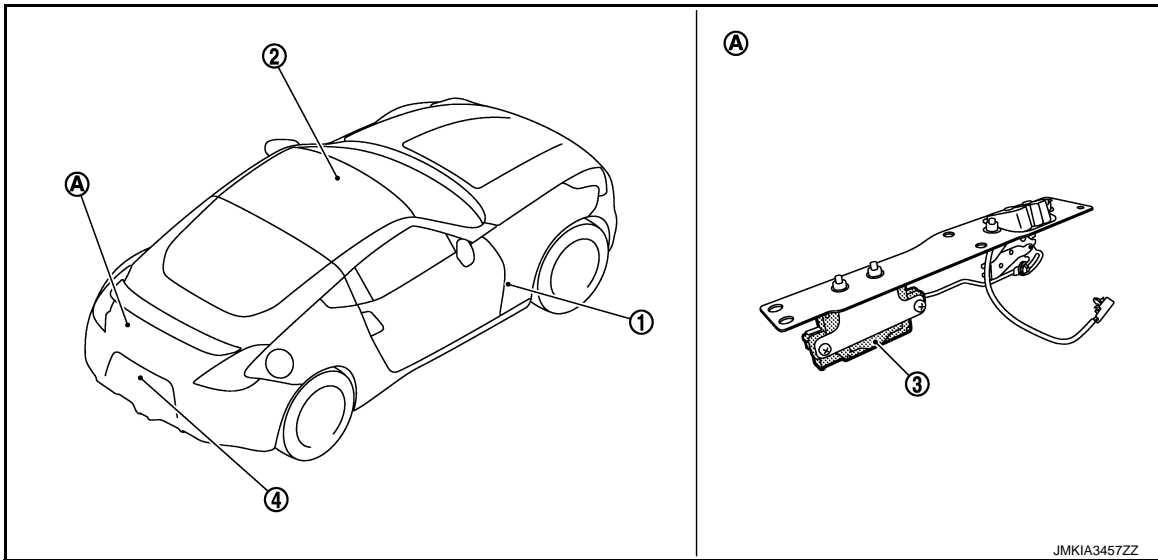

- 1. BCM
- 2. Combination meter
- 3. Back door opener actuator
- 4. Back door opener switch assembly (back door opener switch)
- A. View with luggage rear plate removed

BACK DOOR OPENER SYSTEM : Component Description

INFOID:0000000110840790

Item	Function
BCM	Controls the back door opener function
Back door opener actuator	Refer to DLK-20, "Back Door Opener Actuator"
Back door opener switch	Refer to DLK-21, "Back Door Opener Switch"
Combination meter	Refer to DLK-21, "Combination Meter"

INTEGRATED HOMELINK TRANSMITTER

INTEGRATED HOMELINK TRANSMITTER : Component Description

INFOID:0000000110840791

Item	Function
Integrated homelink transmitter	A maximum of 3 radio signals can be stored and transmitted to operate the garage door, etc.

Door Lock Actuator

INFOID:0000000110840792

Inputs lock/unlock signal from BCM and locks/unlocks each door

Fuel Lid Lock Actuator

INFOID:0000000110840793

Inputs lock/unlock signal from BCM and lock/unlocks fuel filler lid

Back Door Opener Actuator

INFOID:0000000110840794

Opens the back door with the back door open signal from BCM.

Intelligent Key

INFOID:0000000110840795

The following functions are available when having and carrying electronic ID.

BACK DOOR OPENER SYSTEM

< WIRING DIAGRAM >

[COUPE]

BACK DOOR OPENER SYSTEM

Connector No.	M120
Connector Name	BCM (BODY CONTROL MODULE)
Connector Type	NS12FW-CS

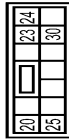

Terminal No.	Color	Wire	Signal Name [Specification]
20	V	L	TURN SIGNAL RH (REAR)
23	L	L	BACK DOOR OPEN OUTPUT (Coupe models)
23	Y	Y	TRUNK LID OPEN OUTPUT (Sedan models)
24	O	O	REAR Fog OUTPUT
26	LG	LG	TURN SIGNAL LH (REAR)
30	R	R	LUGGAGE/TRUNK ROOM LAMP OUTPUT

Connector No.	M121
Connector Name	BCM (BODY CONTROL MODULE)
Connector Type	TH40FGY-NH



Terminal No.	Color	Wire	Signal Name [Specification]
34	G	G	LUGGAGE/TRUNK ROOM ANT-
35	R	R	LUGGAGE/TRUNK ROOM ANT+
38	B	B	REAR BUMPER ANT-
39	W	W	REAR BUMPER ANT+
47	V	V	IGN RELAY (IFDM F/R) CONT
52	SB	SB	STARTER RELAY CONT
60	BR	BR	PUSH SW
61	W	W	BACK DOOR/TRUNK LID DOOR REQUEST SW
64	G	G	L-KEY WARN BUZZER (ENG ROOM)
66	R	R	BACK DOOR/TRUNK ROOM LAMP SW
67	GR	GR	BACK DOOR/TRUNK LID OPENER SW

Connector No.	M122
Connector Name	BCM (BODY CONTROL MODULE)
Connector Type	TH40FB-NH

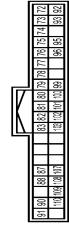

Terminal No.	Color	Wire	Signal Name [Specification]
72	L	L	ROOM ANT 2-
73	P	P	ROOM ANT 2+
74	SB	SB	PASSENGER DOOR ANT-
75	BR	BR	PASSENGER DOOR ANT+
76	V	V	DRIVER DOOR ANT-
77	LG	LG	DRIVER DOOR ANT+
78	L	L	ROOM ANT 1-
79	R	R	ROOM ANT 1+
80	GR	GR	NATS ANT AMP
81	W	W	NATS ANT AMP
82	R	R	IGN RELAY (F/B) CONT
83	GR	GR	KYLS ENT RECEIVER (FRONT) COMM
87	BR	BR	COMBI SW INPUT 5
88	V	V	COMBI SW INPUT 3
90	P	P	CANL
91	L	L	CANH
92	LG	LG	KEY SLOT ILL
93	V	V	ON IND
95	O	O	ACC RELAY CONT
96	Y	Y	AT SHIFT SELECTOR POWER SUPPLY
99	R	R	SHIFT P/CLUTCH PEDAL POS SW
100	GR	GR	PASSENGER DOOR REQUEST SW
101	Y	Y	DRIVER DOOR REQUEST SW
102	O	O	BLOWER FAN MOTOR RELAY CONT
103	LG	LG	KYLS ENT RECEIVER (FRONT) PWR SUPPLY
107	LG	LG	COMBI SW INPUT 4
108	R	R	COMBI SW INPUT 1
109	Y	Y	COMBI SW INPUT 2
110	P	P	HAZARD SW

JRKWD6432GB

VEHICLE SPEED SENSING AUTO LOCK OPERATION DOES NOT OPERATE

< SYMPTOM DIAGNOSIS >

[COUPE]

VEHICLE SPEED SENSING AUTO LOCK OPERATION DOES NOT OPERATE

Diagnosis Procedure

INFOID:000000010840911

1. CHECK POWER DOOR LOCK OPERATION

Check power door lock operation.

Does door lock/unlock with door lock and unlock switch?

YES >> GO TO 2.

NO >> Refer to [DLK-128, "ALL DOOR : Diagnosis Procedure"](#).

2. CHECK "AUTOMATIC LOCK/UNLOCK SELECT" SETTING IN "WORK SUPPORT"

1. Select "DOOR LOCK" of "BCM" using CONSULT.

2. Select "AUTOMATIC LOCK/UNLOCK SELECT" in "WORK SUPPORT" mode.

3. Check "AUTOMATIC LOCK/UNLOCK SELECT" in "WORK SUPPORT".

Refer to [DLK-41, "DOOR LOCK : CONSULT Function \(BCM - DOOR LOCK\) \(For Coupe\)"](#).

Is the inspection result normal?

YES >> GO TO 3.

NO >> Set "AUTOMATIC LOCK/UNLOCK SELECT" in "WORK SUPPORT".

3. CHECK "AUTOMATIC DOOR LOCK SELECT" SETTING IN "WORK SUPPORT"

1. Select "DOOR LOCK" of "BCM" using CONSULT.

2. Select "AUTOMATIC DOOR LOCK SELECT" in "WORK SUPPORT" mode.

3. Check "AUTOMATIC DOOR LOCK SELECT" in "WORK SUPPORT".

Refer to [DLK-41, "DOOR LOCK : CONSULT Function \(BCM - DOOR LOCK\) \(For Coupe\)"](#).

Is the inspection result normal?

YES >> GO TO 4.

NO >> Set "AUTOMATIC DOOR LOCK SELECT" in "WORK SUPPORT".

4. CHECK VEHICLE SPEED SIGNAL

Check combination meter.

Refer to [MWI-77, "DTC Index"](#).

Is the inspection result normal?

YES >> GO TO 5.

NO >> Repair or replace the malfunctioning parts.

5. REPLACE BCM

• Replace BCM. Refer to [BCS-106, "Removal and Installation"](#).

• Confirm the operation after replacement.

Is the result normal?

YES >> INSPECTION END

NO >> Check intermittent incident. Refer to [GI-44, "Intermittent Incident"](#).

BACK DOOR LOCK

[COUPE]

< REMOVAL AND INSTALLATION >

5. Disconnect connector of back door opener actuator.
6. Using a flat-bladed screwdriver (A) disconnect inside handle cable (1) from back door lock (2).

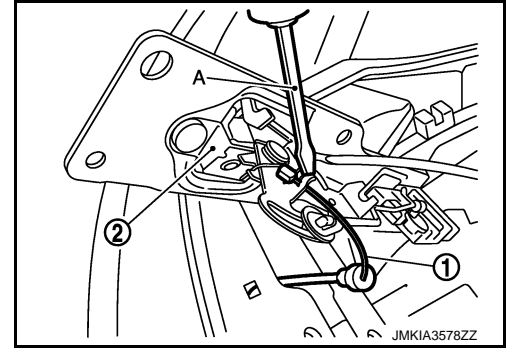

7. Remove back door lock and actuator bracket assembly.
8. Disconnect back door lock and back door opener actuator from back door lock and actuator bracket.
9. Remove following parts. Refer to [JNT-32, "Removal and Installation"](#).
 - Luggage floor carpet assembly
 - Spare tire cover
 - Luggage side finisher upper LH
 - Luggage floor spacer center rear (without BOSE audio)
 - Luggage spacer
 - Luggage side box assembly LH
 - Luggage rear plate
 - Woofer (with BOSE audio)
10. Remove clips and remove inside handle assembly.

INSTALLATION

Install in the reverse order of removal.

CAUTION:

After installation, check back door open/close, lock/unlock operation.

BACK DOOR STRIKER

POWER DOOR LOCK SYSTEM

< WIRING DIAGRAM >

[ROADSTER]

POWER DOOR LOCK SYSTEM

Connector No.	M117
Connector Name	WIRE TO WIPE
Connector Type	TH80MW-CS16-TM4

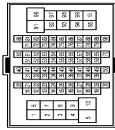

Terminal No.	Color Of Wire	Signal Name [Specification]
2	GR	- [Coupe models]
2	LG	- [Roadster models]
3	B	- [Coupe models]
3	O	- [Roadster models]
4	W	- [Coupe models]
7	G	- [Coupe models]
7	Y	- [Roadster models]
8	LG	-
9	Y	-
11	R	-
20	G	-
21	R	-
30	B	-
40	O	-
41	Y	-
42	G	-
43	L	-
44	SB	-
51	R	-
52	G	-
53	SHIELD	-
54	LG	-
55	V	-
56	SHIELD	-
57	G	- [Coupe models]
57	P	- [Roadster models]
58	L	- [Roadster models]
59	B	- [Coupe models]
60	W	-
61	GR	-
62	B	-
63	Y	-
64	L	-
65	G	-
66	O	-

POWER DOOR LOCK SYSTEM

Connector No.	M118
Connector Name	BCM (BODY CONTROL MODULE)
Connector Type	M03FB-LC



Terminal No.	Color Of Wire	Signal Name [Specification]
67	V	-
68	P	-
69	L	-
70	L	-
71	B	-
72	B	-
73	B	-
74	B	-
75	B	-
76	B	-
77	B	- [Coupe models]
92	G	- [Roadster models]
93	LG	- [Coupe models]
93	R	- [Roadster models]
94	G	- [Roadster models]
94	V	- [Coupe models]
94	SHIELD	- [Roadster models]
95	LG	- [Coupe models]
95	SB	- [Roadster models]
97	G	- [Coupe models]
97	V	- [Roadster models]
98	V/B	- [Coupe models]
99	G	- [Roadster models]
100	BR	- [Coupe models]
100	Y	- [Roadster models]

POWER DOOR LOCK SYSTEM

Connector No.	M119
Connector Name	BCM (BODY CONTROL MODULE)
Connector Type	NS16FY-CS

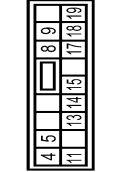

Terminal No.	Color Of Wire	Signal Name [Specification]
4	R	INTERIOR ROOM LAMP POWER SUPPLY
5	G	PASSENGER DOOR UNLOCK OUTPUT
8	V	ALL DOOR FUEL LID LOCK OUTPUT
9	G	DRIVER DOOR FUEL LID UNLOCK OUTPUT
11	BR	BAT (FUSE)
13	B	GROUND
14	R	PUSH-BUTTON IGNITION SW ILL GND
15	Y	ACC IND
17	W	TURN SIGNAL RH (FRONT. SIDE)
18	O	TURN SIGNAL LH (FRONT. SIDE)
19	P	ROOM LAMP TIMER CONTROL

POWER DOOR LOCK SYSTEM

Connector No.	M122
Connector Name	BCM (BODY CONTROL MODULE)
Connector Type	TH40FB-NH

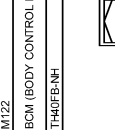

Terminal No.	Color Of Wire	Signal Name [Specification]
72	L	ROOM ANT 2-
73	b	ROOM ANT 2+
74	SB	PASSENGER DOOR ANT-
75	BR	PASSENGER DOOR ANT+
76	V	DRIVER DOOR ANT-
77	LG	DRIVER DOOR ANT+
78	L	ROOM ANT 1-
79	R	ROOM ANT 1+
80	GR	NATS ANT AMP
81	W	NATS ANT AMP
82	R	IGN RELAY (FBI) CONT
83	GR	KYLS ENT RECEIVER (FRONT) COMM
87	BR	COMBI SW INPUT 5
88	V	COMBI SW INPUT 3
90	P	CAN-L
91	L	CAN-H
92	LG	KEY SLOT ILL
93	V	ON IND
95	O	ACC RELAY CONT
96	Y	AT SHIFT SELECTOR POWER SUPPLY
99	R	SHIFT P/CLUTCH PEDAL POS SW
100	GR	PASSENGER DOOR REQUEST SW
101	Y	DRIVER DOOR REQUEST SW
102	O	BLOWER FAN MOTOR RELAY CONT
103	LG	KYLS ENT RECEIVER (FRONT) PWR SUPPLY
107	LG	COMBI SW INPUT 1
108	R	COMBI SW INPUT 4
109	Y	COMBI SW INPUT 2
110	P	HAZARD SW

JRKWD6415GB

DOOR REQUEST SWITCH

< DTC/CIRCUIT DIAGNOSIS >

[ROADSTER]

DOOR REQUEST SWITCH

Component Function Check

INFOID:000000010841085

1. CHECK FUNCTION

1. Select "INTELLIGENT KEY" of "BCM" using CONSULT.
2. Select "REQ SW -DR", "REQ SW -AS", "REQ SW -BD/TR" in "DATA MONITOR" mode.
3. Check that the function operates normally according to the following conditions.

Monitor item	Condition		Status
REQ SW -DR	Driver side door request switch	Pressed	On
		Released	Off
REQ SW -AS	Passenger side door request switch	Pressed	On
		Released	Off
REQ SW -BD/TR	Trunk lid door request switch	Pressed	On
		Released	Off

Is the inspection result normal?

- YES >> Door request switch is OK.
 NO >> Refer to [DLK-310, "Diagnosis Procedure"](#).

Diagnosis Procedure

INFOID:000000010841086

1. CHECK DOOR REQUEST SWITCH INPUT SIGNAL

1. Turn ignition switch OFF.
2. Disconnect malfunctioning door request switch/trunk lid opener switch assembly connector.
3. Check signal between malfunctioning door request switch/trunk lid opener switch assembly harness connector and ground using oscilloscope.

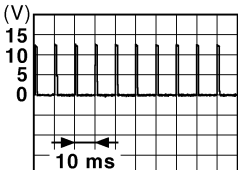
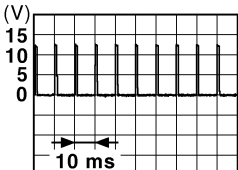
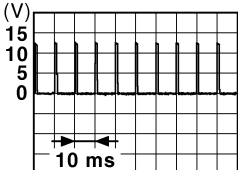
(+)			(-)	Signal (Reference value)
Door request switch/Trunk lid opener switch assembly				
Connector	Terminal			
Driver side	D13	1	Ground	 <small>JPMIA0016GB</small>
Passenger side	D43	2		 <small>JPMIA0016GB</small>
Trunk lid	B156	2		 <small>JPMIA0016GB</small>

HOOD

< REMOVAL AND INSTALLATION >

[ROADSTER]

- Check hood hinge rotating part for poor lubrication. If necessary, apply body grease.
- After installation, check hood open/close, lock/unlock operation.
- After installation, adjust the following parts.
- Hood: Refer to [DLK-368, "HOOD ASSEMBLY : Adjustment"](#).
- Washer nozzle (LH/RH) and washer tube: Refer to [WW-47, "Removal and Installation"](#).
- After installation, apply touch-up paint (the body color) onto the heads of hood hinge mounting bolts and nuts.

HOOD ASSEMBLY : Adjustment

INFOID:000000010841158

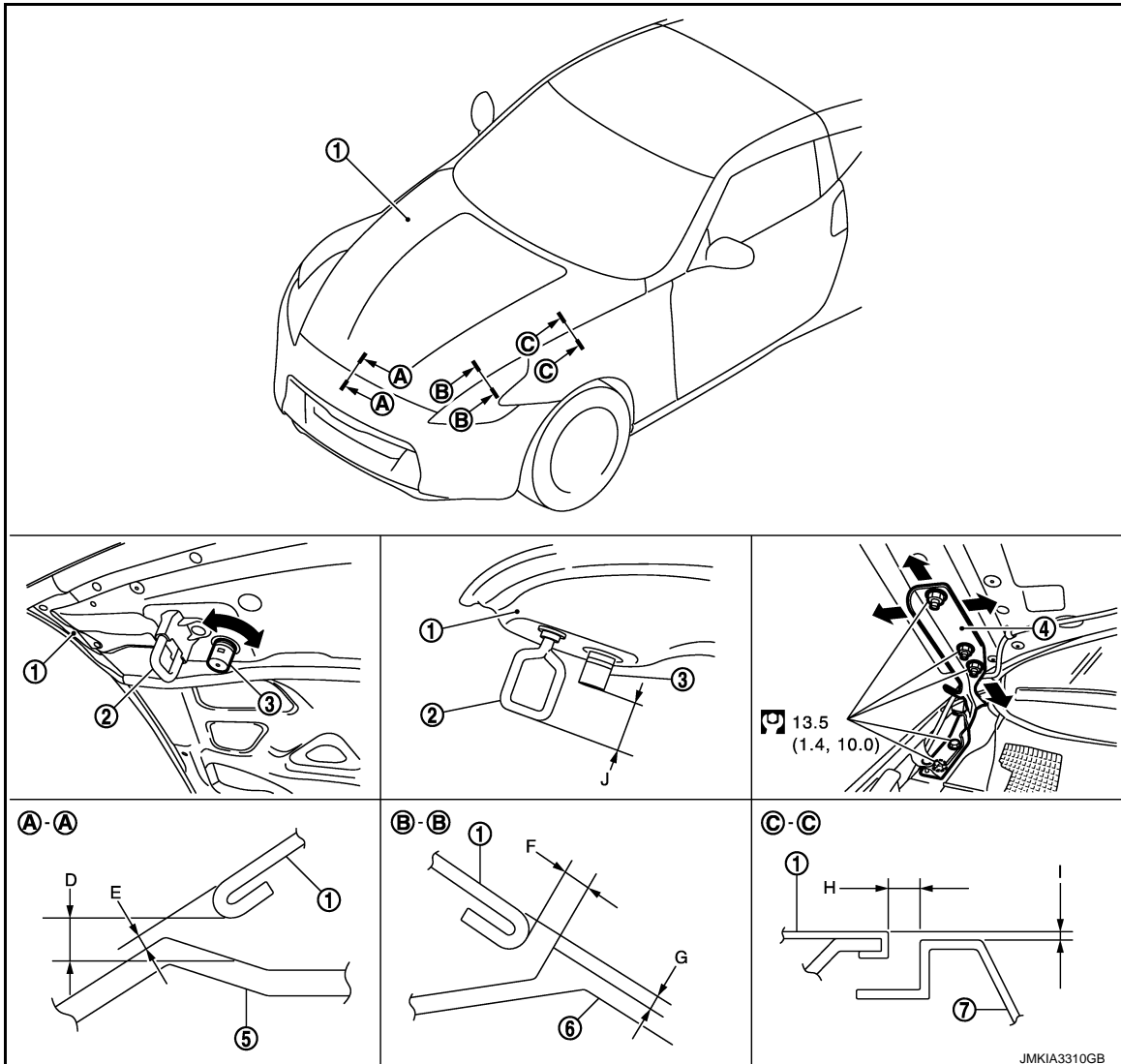

- | | | |
|------------------|------------------------|---------------------------|
| 1. Hood assembly | 2. Hood striker | 3. Hood bumper rubber |
| 4. Hood hinge | 5. Front bumper fascia | 6. Front combination lamp |
| 7. Front fender | | |

: N·m (kg·m, ft·lb)

Check the clearance and the surface height between hood and each part by seeing and touching. Fitting standard dimension in the table below should be satisfied.

If the clearance and the surface height are out of specification, adjust them according to the procedures shown below.

PERIODIC MAINTENANCE

REAR DIFFERENTIAL GEAR OIL

Inspection

INFOID:0000000010838764

OIL LEAKAGE

Make sure that oil is not leaking from final drive assembly or around it.

OIL LEVEL

- Remove filler plug (1) and check oil level from filler plug mounting hole as shown in the figure.

CAUTION:

Never start engine while checking oil level.

- Set a gasket on filler plug and install it on final drive assembly. Refer to [DLN-28, "Exploded View"](#).

CAUTION:

Never reuse gasket.

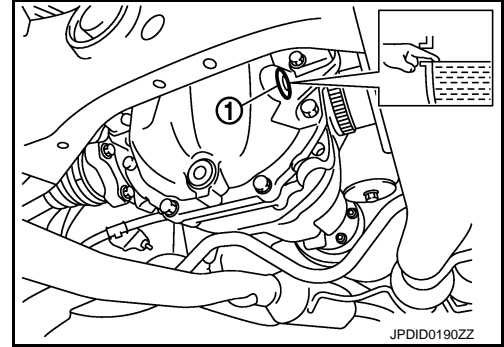

Draining

INFOID:0000000010838765

- Stop the engine.
- Remove drain plug (1) and drain gear oil.
- Set a gasket on drain plug and install it to final drive assembly and tighten to the specified torque. Refer to [DLN-28, "Exploded View"](#).

CAUTION:

Never reuse gasket.

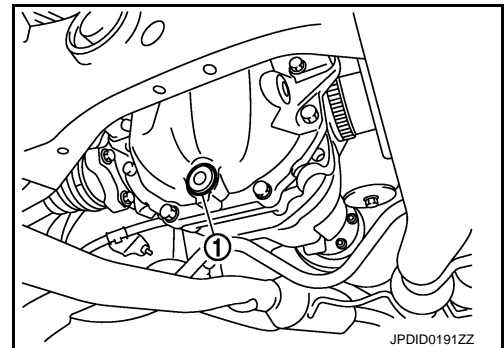

Refilling

INFOID:0000000010838766

- Remove filler plug (1). Fill with new gear oil until oil level reaches the specified level near filler plug mounting hole.

Oil grade, viscosity, and capacity

: Refer to [MA-16, "FOR NORTH AMERICA : Fluids and Lubricants"](#) (for NORTH AMERICA), [MA-17, "FOR MEXICO : Fluids and Lubricants"](#) (for MEXICO).

- After refilling oil, check oil level. Set a gasket to filler plug, then install it to final drive assembly. Refer to [DLN-28, "Exploded View"](#).

CAUTION:

Never reuse gasket.

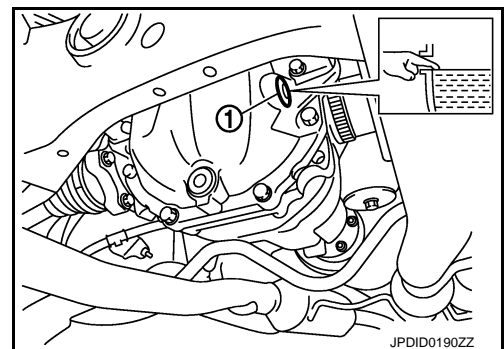

DIFFERENTIAL ASSEMBLY

< UNIT DISASSEMBLY AND ASSEMBLY >

[REAR FINAL DRIVE: R200V]

2. Fit a dial indicator to the drive gear back face.
3. Rotate the drive gear to measure runout.

Drive gear runout : Refer to [DLN-88, "Drive Gear Runout"](#).

- If the runout is outside of the repair limit, check drive gear assembly condition; foreign material may be caught between drive gear and differential case, or differential case or drive gear may be deformed, etc.

CAUTION:

Replace drive gear and drive pinion gear as a set.

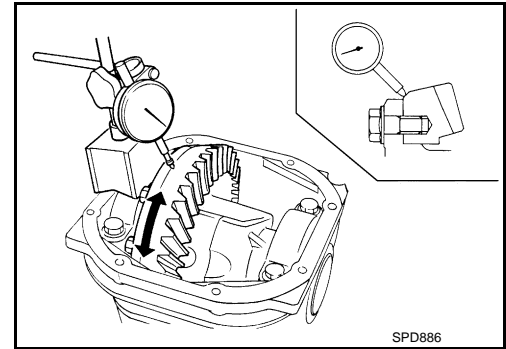

TOOTH CONTACT

- Before inspection and adjustment, drain gear oil.
1. Remove rear cover. Refer to [DLN-68, "Disassembly"](#).

2. Apply red lead to drive gear.

CAUTION:

Apply red lead to both the faces of 3 to 4 gears at 4 locations evenly spaced on drive gear.

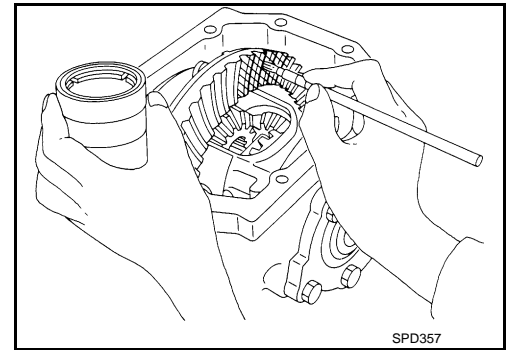

3. Rotate drive gear back and forth several times, check drive pinion gear to drive gear tooth contact.

CAUTION:

Check tooth contact on drive side and reverse side.

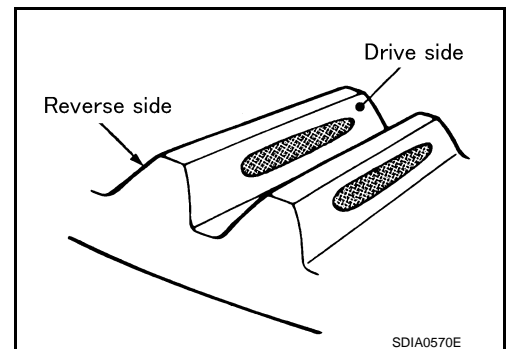

ENGINE CONTROL SYSTEM

< SYSTEM DESCRIPTION >

[VQ37VHR]

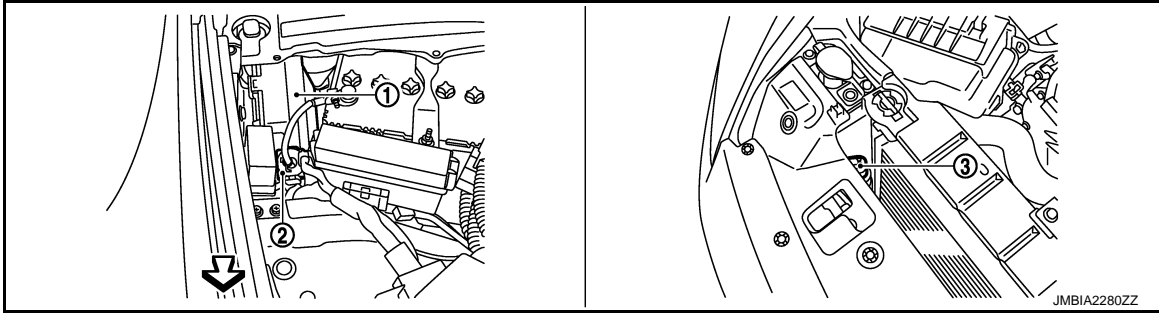

↙ : Vehicle front

- 1. IPDM E/R
- 2. Battery current sensor
- 3. Refrigerant pressure sensor

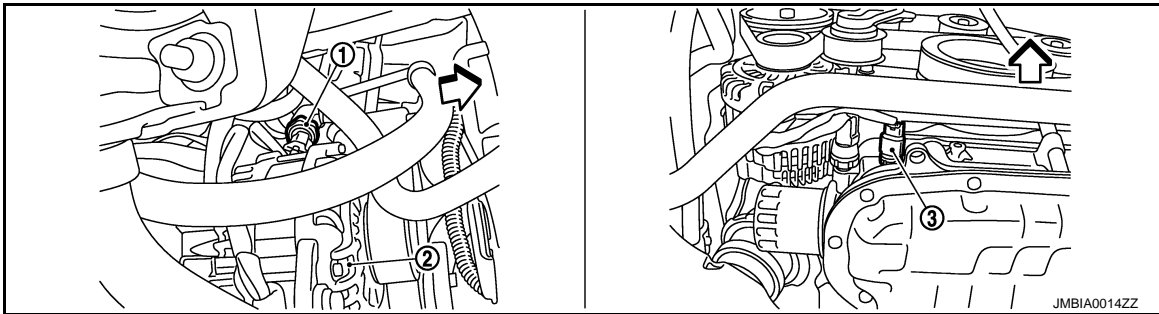

↙ : Vehicle front

- 1. Power steering pressure sensor
- 2. Alternator
- 3. Engine oil temperature sensor

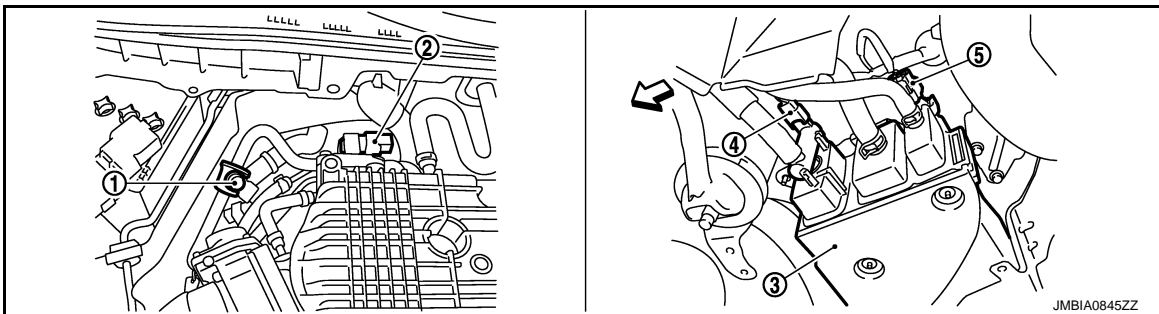

↙ : Vehicle front

- 1. EVAP service port
- 2. EVAP canister purge volume control
- 3. EVAP canister solenoid valve
- 4. EVAP canister vent control valve
- 5. EVAP control system pressure sensor

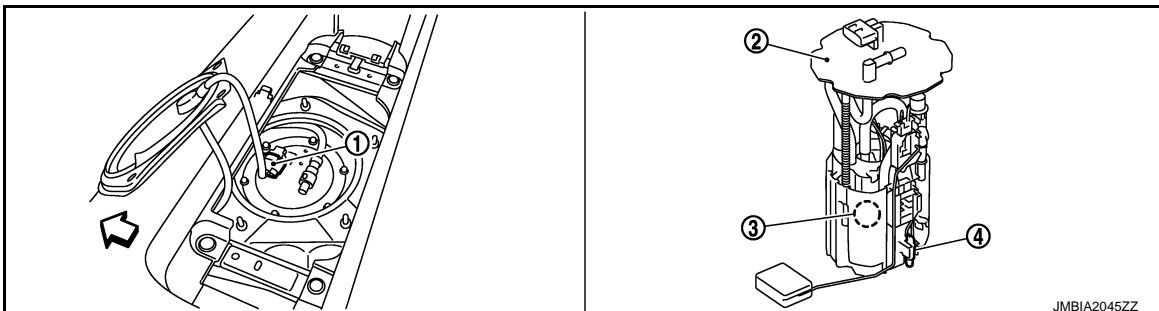

A
EC
C
D
E
F
G
H
I
J
K
L
M
N
O
P

EVAPORATIVE EMISSION SYSTEM

[VQ37VHR]

< SYSTEM DESCRIPTION >

↖: Vehicle front

1. Heated oxygen sensor 2 (bank 2)
2. Heated oxygen sensor 2 (bank 2) harness connector
3. Heated oxygen sensor 2 (bank 1)
4. Heated oxygen sensor 2 (bank 1) harness connector

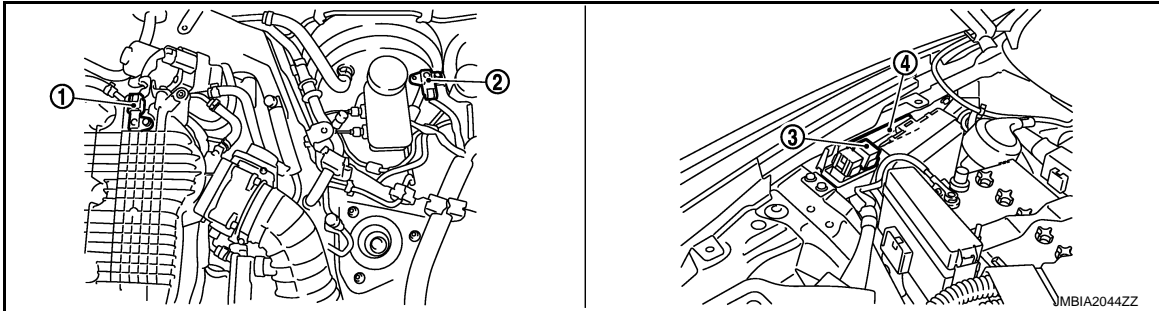

1. Manifold absolute pressure (MAP) sensor
2. Brake booster pressure sensor
3. VVEL actuator motor relay
4. VVEL control module



↖: Vehicle front

1. VVEL control shaft position sensor (bank 1)
2. VVEL actuator motor (bank 1)
3. VVEL actuator motor (bank 2)
4. VVEL control shaft position sensor (bank 2)

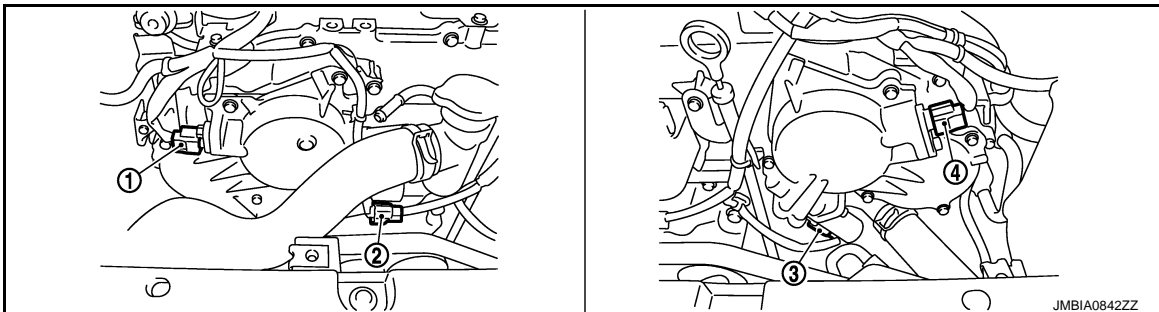

1. Camshaft position sensor (PHASE) (bank 1)
2. Intake valve timing control solenoid valve (bank 1) harness connector
3. Intake valve timing control solenoid valve (bank 2) harness connector
4. Camshaft position sensor (PHASE) (bank 2)

A
EC
C
D
E
F
G
H
I
J
K
L
M
N
O
P

DIAGNOSIS SYSTEM (ECM)

[VQ37VHR]

< SYSTEM DESCRIPTION >

Monitored item	Unit	Description	Remarks
ALT DUTY SIG	ON/OFF	<ul style="list-style-type: none"> The control condition of the power generation voltage variable control (determined by ECM according to the input signals) is indicated. ON: Power generation voltage variable control is active. OFF: Power generation voltage variable control is inactive. 	
GEAR POSITION	1/2/3/4/5/6/N/R/##	<ul style="list-style-type: none"> Indicates the shift position determined by the ECM according to the input signals. 	"##" is displayed when shift position cannot be judged.
M/T SYN REV STAT	INACT/ACTIVE	<ul style="list-style-type: none"> Displays SynchroRev Match mode (S-MODE) is condition. INACT: S-MODE is not operated ACTIVE: S-MODE is operated 	
M/T SYNCHRO SW	ON/OFF	<ul style="list-style-type: none"> Indicates [ON/OFF] condition from S-MODE switch signal. 	
CPP SW	ON/OFF	<ul style="list-style-type: none"> Indicates [ON/OFF] condition from clutch pedal position switch signal. 	
CLUTCH INTLCK SW	ON/OFF	<ul style="list-style-type: none"> Indicates [ON/OFF] condition from clutch interlock switch signal. 	
M/T N POS LEARN	YET/DONE	<ul style="list-style-type: none"> Displays the M/T Neutral Position Learning condition. YET: M/T neutral position learning is not complete yet. DONE: M/T neutral position learning is successfully complete. 	
THRTL STK CNT B1*	—	—	
HO2 S2 DIAG1 (B1)	INCMP/CMPLT	<ul style="list-style-type: none"> Indicates DTC P0139 self-diagnosis (delayed response) condition. INCMP: Self-diagnosis is incomplete. CMPLT: Self-diagnosis is complete. 	
HO2 S2 DIAG1 (B2)	INCMP/CMPLT	<ul style="list-style-type: none"> Indicates DTC P0159 self-diagnosis (delayed response) condition. INCMP: Self-diagnosis is incomplete. CMPLT: Self-diagnosis is complete. 	
HO2 S2 DIAG2 (B1)	INCMP/CMPLT	<ul style="list-style-type: none"> Indicates DTC P0139 self-diagnosis (slow response) condition. INCMP: Self-diagnosis is incomplete. CMPLT: Self-diagnosis is complete. 	
HO2 S2 DIAG2 (B2)	INCMP/CMPLT	<ul style="list-style-type: none"> Indicates DTC P0159 self-diagnosis (slow response) condition. INCMP: Self-diagnosis is incomplete. CMPLT: Self-diagnosis is complete. 	
A/F SEN1 DIAG1 (B1)	INCMP/CMPLT	<ul style="list-style-type: none"> Indicates DTC P015A or P015B self-diagnosis condition. INCMP: Self-diagnosis is incomplete. CMPLT: Self-diagnosis is complete. 	
A/F SEN1 DIAG1 (B2)	INCMP/CMPLT	<ul style="list-style-type: none"> Indicates DTC P015C or P015D self-diagnosis condition. INCMP: Self-diagnosis is incomplete. CMPLT: Self-diagnosis is complete. 	
A/F SEN1 DIAG2 (B1)	INCMP/CMPLT	<ul style="list-style-type: none"> Indicates DTC P014C or P014D self-diagnosis condition. INCMP: Self-diagnosis is incomplete. CMPLT: Self-diagnosis is complete. 	
A/F SEN1 DIAG2 (B2)	INCMP/CMPLT	<ul style="list-style-type: none"> Indicates DTC P014E or P014F self-diagnosis condition. INCMP: Self-diagnosis is incomplete. CMPLT: Self-diagnosis is complete. 	

A

EC

C

D

E

F

G

H

I

J

K

L

M

N

O

P

P0116 ECT SENSOR

[VQ37VHR]

< DTC/CIRCUIT DIAGNOSIS >

If DTC Confirmation Procedure has been previously conducted, always perform the following procedure before conducting the next test.

1. Turn ignition switch OFF and wait at least 10 seconds.
2. Turn ignition switch ON.
3. Turn ignition switch OFF and wait at least 10 seconds.

TEST CONDITION:

- Before performing the following procedure, do not add fuel.
- Before performing the following procedure, check that fuel level is between 1/4 and 4/4.
- Before performing the following procedure, confirm that battery voltage is 11 V or more at idle.

>> GO TO 4.

4. PERFORM DTC CONFIRMATION PROCEDURE

1. Start engine and let it idle for 60 minutes.
2. Move the vehicle to a cool place.

NOTE:

Cool the vehicle in an environment of ambient air temperature between -10°C (14°F) and 35°C (95°F).

3. Turn ignition switch OFF and soak the vehicle for 12 hours.

CAUTION:

Never turn ignition switch ON during soaking.

NOTE:

The vehicle must be cooled with the hood open.

4. Start engine and let it idle for 5 minutes or more.

CAUTION:

Never turn ignition switch OFF during idling.

5. Check 1st trip DTC.

Is 1st trip DTC detected?

YES >> Proceed to [EC-219, "Diagnosis Procedure"](#).

NO >> INSPECTION END

Component Function Check

INFOID:000000010839523

1. CHECK ENGINE COOLANT TEMPERATURE (ECT) SENSOR

1. Turn ignition switch OFF.
2. Disconnect ECT sensor harness connector.
3. Remove ECT sensor. Refer to [CO-29, "Exploded View"](#)
4. Check resistance between ECT sensor terminals by heating with hot water as shown in the figure.

Terminals	Condition	Resistance (kΩ)	
1 and 2	Temperature [°C (°F)]	20 (68)	2.10 - 2.90
		50 (122)	0.68 - 1.00
		90 (194)	0.236 - 0.260

Is the inspection result normal?

YES >> GO TO 2.

NO >> Proceed to [EC-219, "Diagnosis Procedure"](#).

2. CHECK INTERMITTENT INCIDENT

Check intermittent incident. Refer to [GI-44, "Intermittent Incident"](#).

Is the inspection result normal?

YES >> INSPECTION END

NO >> Proceed to [EC-219, "Diagnosis Procedure"](#).

Diagnosis Procedure

INFOID:000000010839524

1. CHECK ENGINE COOLANT TEMPERATURE (ECT) SENSOR

Check ECT sensor. Refer to [EC-220, "Component Inspection"](#).

A

EC

C

D

E

F

G

H

I

J

K

L

M

N

O

P

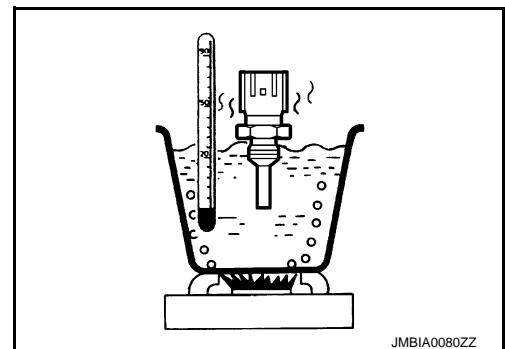

P0172, P0175 FUEL INJECTION SYSTEM FUNCTION

< DTC/CIRCUIT DIAGNOSIS >

[VQ37VHR]

5. PERFORM DTC CONFIRMATION PROCEDURE-III

1. Turn ignition switch OFF and wait at least 5 seconds.
2. Turn ignition switch ON.
3. Start engine.
4. Maintain the following conditions for at least 10 consecutive minutes.
Hold the accelerator pedal as steady as possible.

VHCL SPEED SE	50 - 120 km/h (31 - 75 MPH)
---------------	-----------------------------

CAUTION:

Always drive vehicle at a safe speed.

5. Check 1st trip DTC.

Is 1st trip DTC detected?

- YES >> Go to [EC-277, "Diagnosis Procedure"](#).
NO >> INSPECTION END

Diagnosis Procedure

INFOID:0000000010839575

1. CHECK EXHAUST GAS LEAK

1. Start engine and run it at idle.
2. Listen for an exhaust gas leak before three way catalyst 1.

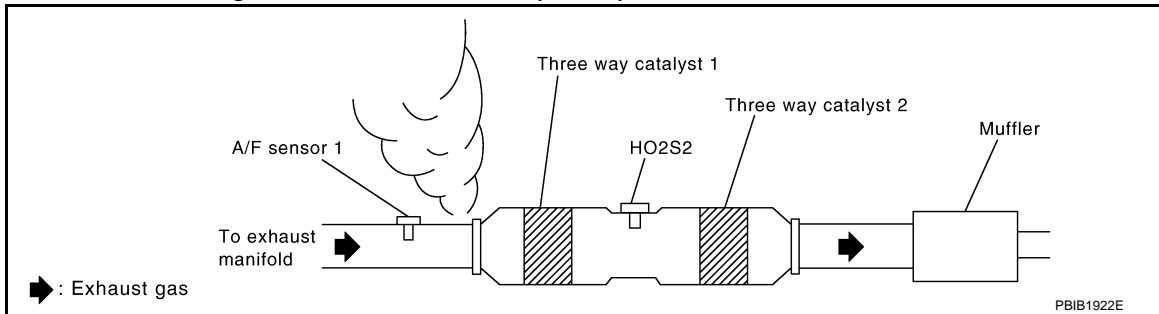

Is exhaust gas leak detected?

- YES >> Repair or replace.
NO >> GO TO 2.

2. CHECK FOR INTAKE AIR LEAK

Listen for an intake air leak after the mass air flow sensor.

Is intake air leak detected?

- YES >> Repair or replace.
NO >> GO TO 3.

3. CHECK A/F SENSOR 1 INPUT SIGNAL CIRCUIT

1. Turn ignition switch OFF.
2. Disconnect corresponding A/F sensor 1 harness connector.
3. Disconnect ECM harness connector.
4. Check the continuity between A/F sensor 1 harness connector and ECM harness connector.

DTC	A/F sensor 1			ECM		Continuity
	Bank	Connector	Terminal	Connector	Terminal	
P0172	1	F61	1	F102	57	Existed
			2		61	
P0175	2	F62	1		65	
			2		66	

5. Check the continuity between A/F sensor 1 harness connector and ground, or ECM harness connector and ground.

P0447 EVAP CANISTER VENT CONTROL VALVE

[VQ37VHR]

< DTC/CIRCUIT DIAGNOSIS >

- YES >> GO TO 3.
- NO >> Replace EVAP canister vent control valve.

3. CHECK EVAP CANISTER VENT CONTROL VALVE-III

With CONSULT

1. Clean the air passage [portion (A) to (B)] of EVAP canister vent control valve using an air blower.
2. Perform "VENT CONTROL/V" in "ACTIVE TEST" mode.
3. Check air passage continuity and operation delay time.
Make sure that new O-ring is installed properly.

Condition VENT CONT/V	Air passage continuity between (A) and (B)
ON	Not existed
OFF	Existed

Operation takes less than 1 second.

Without CONSULT

1. Clean the air passage [portion (A) to (B)] of EVAP canister vent control valve using an air blower.
2. Check air passage continuity and operation delay time under the following conditions.
Make sure that new O-ring is installed properly.

Condition	Air passage continuity between (A) and (B)
12 V direct current supply between terminals 1 and 2	Not existed
OFF	Existed

Operation takes less than 1 second.

Is the inspection result normal?

- YES >> INSPECTION END
- NO >> Replace EVAP canister vent control valve.

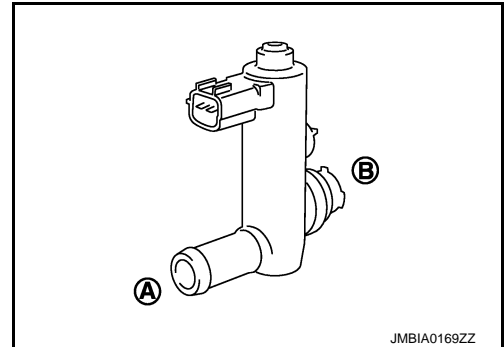

A
EC
C
D
E
F
G
H
I
J
K
L
M
N
O
P

P0643 SENSOR POWER SUPPLY

< DTC/CIRCUIT DIAGNOSIS >

[VQ37VHR]

P0643 SENSOR POWER SUPPLY

DTC Logic

INFOID:000000010839695

DTC DETECTION LOGIC

DTC No.	Trouble diagnosis name	DTC detecting condition	Possible cause
P0643	Sensor power supply circuit short	ECM detects that the voltage of power source for sensor is excessively low or high.	<ul style="list-style-type: none">• Harness or connectors (APP sensor 1 circuit is shorted.) (TP sensor circuit is shorted.) [CMP sensor (PHASE) (bank 1) circuit is shorted.] [Manifold absolute pressure (MAP) sensor circuit is shorted.] (PSP sensor circuit is shorted.) [CMP sensor (PHASE) (bank 2) circuit is shorted.]• Accelerator pedal position sensor• Throttle position sensor• Camshaft position sensor (PHASE) (bank 1)• Manifold absolute pressure (MAP) sensor• Power steering pressure sensor• Camshaft position sensor (PHASE) (bank 2)

DTC CONFIRMATION PROCEDURE

1. PRECONDITIONING

If DTC Confirmation Procedure has been previously conducted, always perform the following procedure before conducting the next test.

1. Turn ignition switch OFF and wait at least 10 seconds.
2. Turn ignition switch ON.
3. Turn ignition switch OFF and wait at least 10 seconds.

TESTING CONDITION:

Before performing the following procedure, confirm that battery voltage is more than 10 V at idle.

>> GO TO 2.

2. PERFORM DTC CONFIRMATION PROCEDURE

1. Start engine and let it idle for 1 second.
2. Check DTC.

Is DTC detected?

- YES >> Go to [EC-393, "Diagnosis Procedure"](#).
NO >> INSPECTION END

Diagnosis Procedure

INFOID:000000010839696

1. CHECK GROUND CONNECTION

1. Turn ignition switch OFF.
2. Check ground connection M95. Refer to Ground Inspection in [GI-47, "Circuit Inspection"](#).

Is the inspection result normal?

- YES >> GO TO 2.
NO >> Repair or replace ground connection.

2. CHECK ACCELERATOR PEDAL POSITION SENSOR 1 POWER SUPPLY CIRCUIT

1. Disconnect accelerator pedal position (APP) sensor harness connector.
2. Turn ignition switch ON.
3. Check the voltage between APP sensor harness connector and ground.

>> INSPECTION END

7. CHECK INTERMITTENT INCIDENT

Refer to [GI-44. "Intermittent Incident"](#).

>> INSPECTION END

Component Inspection

INFOID:0000000010839764

1. CHECK THROTTLE POSITION SENSOR

1. Turn ignition switch OFF.
2. Reconnect all harness connectors disconnected.
3. Perform [EC-20. "THROTTLE VALVE CLOSED POSITION LEARNING : Special Repair Requirement"](#).
4. Turn ignition switch ON.
5. Set selector lever to D (A/T) or 1st (M/T) position.
6. Check the voltage between ECM harness connector terminals as per the following.

Connector	ECM		Condition	Voltage (V)
	+	-		
	Terminal	Terminal		
F101	30 [TP sensor 1 (bank 1)]	40	Fully released	More than 0.36
			Fully depressed	Less than 4.75
	31 [TP sensor 1 (bank 2)]	48	Fully released	More than 0.36
			Fully depressed	Less than 4.75
	34 [TP sensor 2 (bank 1)]	40	Fully released	Less than 4.75
			Fully depressed	More than 0.36
	35 [TP sensor 2 (bank 2)]	48	Fully released	Less than 4.75
			Fully depressed	More than 0.36

Is the inspection result normal?

- YES >> INSPECTION END
 NO >> GO TO 2.

2. REPLACE ELECTRIC THROTTLE CONTROL ACTUATOR

Replace malfunctioning electric throttle control actuator. Refer to [EM-34. "Exploded View"](#).

>> INSPECTION END

FUEL INJECTOR

< DTC/CIRCUIT DIAGNOSIS >

[VQ37VHR]

Fuel injector			Ground	Voltage
Cylinder	Connector	Terminal		
1	F121	1	Ground	Battery voltage
2	F122	1		
3	F123	1		
4	F124	1		
5	F125	1		
6	F126	1		

Is the inspection result normal?

- YES >> GO TO 3.
- NO >> GO TO 2.

2.DETECT MALFUNCTIONING PART

Check the following.

- Harness connectors E3, F1
- Harness connectors F10, F120
- IPDM E/R harness connector E7
- 10 A fuse (No. 44)
- Harness for open or short between fuel injector and fuse

>> Repair open circuit, short to ground or short to power in harness or connectors.

3.CHECK FUEL INJECTOR OUTPUT SIGNAL CIRCUIT FOR OPEN AND SHORT

1. Turn ignition switch OFF.
2. Disconnect ECM harness connector.
3. Check the continuity between fuel injector harness connector and ECM harness connector.

Fuel injector			ECM		Continuity
Cylinder	Connector	Terminal	Connector	Terminal	
1	F121	2	F102	89	Existed
2	F122	2		85	
3	F123	2		81	
4	F124	2		90	
5	F125	2		86	
6	F126	2		82	

4. Also check harness for short to ground and short to power.

Is the inspection result normal?

- YES >> GO TO 5.
- NO >> GO TO 4

4.DETECT MALFUNCTIONING PART

Check the following.

- Harness connectors F106, F107
- Harness connectors F10, F120
- Harness for open or short between fuel injector and ECM

>> Repair open circuit, short to ground or short to power in harness or connectors.

5.CHECK FUEL INJECTOR

Refer to [EC-510. "Component Inspection"](#).

Is the inspection result normal?

ENGINE CONTROL SYSTEM

Connector No.	F61
Connector Name	ARR FUEL RATIO (A/F) SENSOR 1 (BANK 1)
Connector Type	RH04FDGY-P



Terminal No.	Color Of Wire	Signal Name [Specification]
1	L	-
2	R	-
3	O	-
4	Y	-

Connector No.	F62
Connector Name	ARR FUEL RATIO (A/F) SENSOR 1 (BANK 2)
Connector Type	RH04FDGY-P



Terminal No.	Color Of Wire	Signal Name [Specification]
1	LG	-
2	V	-
3	W	-
4	Y	-

Connector No.	F101
Connector Name	ECM
Connector Type	RH40FERRZ8-LH-Z

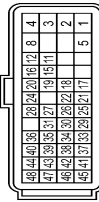

Terminal No.	Color Of Wire	Signal Name [Specification]
1	O	A/F SENSOR 1 HEATER (BANK 1)
2	G	THROTTLE CONTROL MOTOR (OPEN) (BANK 1)
3	R	THROTTLE CONTROL MOTOR (CLOSE) (BANK 1)
4	BR	THROTTLE CONTROL MOTOR (CLOSE) (BANK 2)
8	B	ECM GROUND
11	GR	IGNITION SIGNAL NO. 4
12	L	IGNITION SIGNAL NO. 3
15	V	IGNITION SIGNAL NO. 5
16	G	IGNITION SIGNAL NO. 2
17	P	HEATED OXYGEN SENSOR 2 HEATER (BANK 1)
18	W	INTAKE VALVE TIMING CONTROL (SOLENOID VALVE (BANK 1))
19	SB	IGNITION SIGNAL NO. 6
20	Y	IGNITION SIGNAL NO. 1
21	GR	TEMP-CAMSHAFT POSITION SENSOR (PHASE) (BANK 1)
22	R	FUEL PUMP RELAY
24	P	ECM RELAY (SELF SHUT-OFF)
25	O	THROTTLE CONTROL MOTOR RELAY
26	W	GEAR LEVER POSITION SENSOR X-AXIS
27	G	GEAR LEVER POSITION SENSOR Y-AXIS
28	BR	VALVE ADJUSTER RELAY (START SIGNAL LEVEL CONTROL) (BANK 1)
29	G	INTAKE VALVE TIMING CONTROL (SOLENOID VALVE (BANK 2))
30	Y	THROTTLE POSITION SENSOR 1 (BANK 1)
31	R	THROTTLE POSITION SENSOR 1 (BANK 2)
33	SB	HEATED OXYGEN SENSOR 2 HEATER (BANK 2)
34	B	THROTTLE POSITION SENSOR 2 (BANK 1)
35	W	THROTTLE POSITION SENSOR 2 (BANK 2)
36	O	SENSOR GROUND
37	W	CRANKSHAFT POSITION SENSOR (POS)
38	O	MANIFOLD ABSOLUTE PRESSURE (MAP) SENSOR
39	P	MASS AIR FLOW SENSOR (BANK 1)
40	R	BRAKE BOOSTER PRESSURE SENSOR
41	SB	SENSOR GROUND
42	GR	CLUTCH PEDAL POSITION SENSOR
43	G	CLUTCH INTERLOCK SWITCH
44	L	SENSOR POWER SUPPLY

45	LG	SENSOR POWER SUPPLY
46	R	SENSOR POWER SUPPLY
47	Y	SENSOR GROUND
48	B	SENSOR GROUND

Connector No.	F102
Connector Name	ECM
Connector Type	RH40FERRZ8-LH-Z

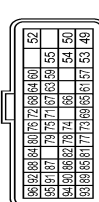

Terminal No.	Color Of Wire	Signal Name [Specification]
49	GR	THROTTLE CONTROL MOTOR (CLOSE) (BANK 2)
50	V	THROTTLE CONTROL MOTOR (OPEN) (BANK 2)
52	R	THROTTLE CONTROL MOTOR (POWER SUPPLY) (BANK 2)
53	W	IGNITION SWITCH
54	Y	ENGINE COMMUNICATION LINE
55	LG	ENGINE COMMUNICATION LINE
57	L	A/F SENSOR 1 (BANK 1)
58	O	CAMSHAFT POSITION SENSOR (PHASE) (BANK 1)
60	G	SENSOR POWER SUPPLY
61	R	A/F SENSOR 1 (BANK 1)
63	L	CAMSHAFT POSITION SENSOR (PHASE) (BANK 2)
64	SB	SENSOR POWER SUPPLY
65	LG	A/F SENSOR 1 (BANK 2)
66	V	A/F SENSOR 1 (BANK 2)
67	P	INTAKE AIR TEMPERATURE SENSOR (BANK 1)
68	LG	SENSOR GROUND
69	W	KNOCK SENSOR (BANK 2)
71	Y	ENGINE COOLANT TEMPERATURE SENSOR
72	SHIELD	SENSOR GROUND
73	W	KNOCK SENSOR (BANK 1)
74	L	SENSOR POWER SUPPLY
75	W	INPUT SPEED SENSOR
76	W	HEATED OXYGEN SENSOR 2 (BANK 1)
77	SB	MASS AIR FLOW SENSOR (BANK 1)
78	G	ENGINE OIL TEMPERATURE SENSOR
79	BR	MASS AIR FLOW SENSOR (BANK 2)
80	O	HEATED OXYGEN SENSOR 2 (BANK 2)
81	R	FUEL INJECTOR NO. 3
82	V	FUEL INJECTOR NO. 6
84	B	SENSOR GROUND

85	BR	FUEL INJECTOR NO. 2
86	W	FUEL INJECTOR NO. 5
87	Y	POWER STEERING PRESSURE SENSOR
88	R	SENSOR GROUND
89	GR	FUEL INJECTOR NO. 1
90	O	FUEL INJECTOR NO. 4
91	SB	BATTERY CURRENT SENSOR
92	G	SENSOR GROUND
93	P	POWER SUPPLY FOR ECM (BACK-UP)
94	Y	SENSOR GROUND
95	G	SENSOR GROUND
96	P	SENSOR GROUND

Connector No.	F103
Connector Name	WIRE TO WIRE
Connector Type	TK38FHY-NS10



Terminal No.	Color Of Wire	Signal Name [Specification]
2	G	-
3	W	-
4	R	-
5	B	-
8	L	-
9	Y	-
10	GR	-
19	O	-
20	Y	-
28	B	-
29	LG	-
30	R	-
31	O	-
39	W	-
42	G	-
43	P	-
44	L	-
45	Y	-
46	V	-

A
EC
C
D
E
F
G
H
I
J
K
L
M
N
O
P

PRECAUTIONS

[VQ37VHR]

< PRECAUTION >

FOR MEXICO : Precautions for Removing Battery Terminal

INFOID:000000011229743

- When removing the 12V battery terminal, turn OFF the ignition switch and wait at least 30 seconds.

NOTE:

ECU may be active for several tens of seconds after the ignition switch is turned OFF. If the battery terminal is removed before ECU stops, then a DTC detection error or ECU data corruption may occur.

- For vehicles with the 2-batteries, be sure to connect the main battery and the sub battery before turning ON the ignition switch.

NOTE:

If the ignition switch is turned ON with any one of the terminals of main battery and sub battery disconnected, then DTC may be detected.

- After installing the 12V battery, always check "Self Diagnosis Result" of all ECUs and erase DTC.

NOTE:

The removal of 12V battery may cause a DTC detection error.

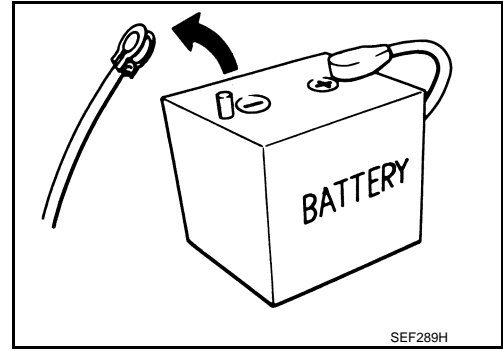

FOR MEXICO : On Board Diagnostic (OBD) System of Engine and A/T

INFOID:000000010839880

The ECM has an on board diagnostic system. It will illuminate the malfunction indicator lamp (MIL) to warn the driver of a malfunction causing emission deterioration.

CAUTION:

- Always turn the ignition switch OFF and disconnect the negative battery cable before any repair or inspection work. The open/short circuit of related switches, sensors, solenoid valves, etc. will cause the MIL to illuminate.
- Always connect and lock the connectors securely after work. A loose (unlocked) connector will cause the MIL to illuminate due to the open circuit. (Be sure the connector is free from water, grease, dirt, bent terminals, etc.)
- Certain systems and components, especially those related to OBD, may use a new style slide-locking type harness connector. For description and how to disconnect, refer to [PG-94, "Description"](#).
- Always route and secure the harnesses properly after work. The interference of the harness with a bracket, etc. may cause the MIL to illuminate due to the short circuit.
- Always connect rubber tubes properly after work. A misconnected or disconnected rubber tube may cause the MIL to illuminate due to the malfunction of the EVAP system or fuel injection system, etc.
- Always erase the unnecessary malfunction information (repairs completed) from the ECM and TCM (Transmission control module) before returning the vehicle to the customer.

FOR MEXICO : General Precautions

INFOID:000000010839881

- Always use a 12 volt battery as power source.
- Never attempt to disconnect battery cables while engine is running.
- Before connecting or disconnecting the ECM harness connector, turn ignition switch OFF and disconnect negative battery cable. Failure to do so may damage the ECM because battery voltage is applied to ECM even if ignition switch is turned OFF.
- Before removing parts, turn ignition switch OFF and then disconnect negative battery cable.

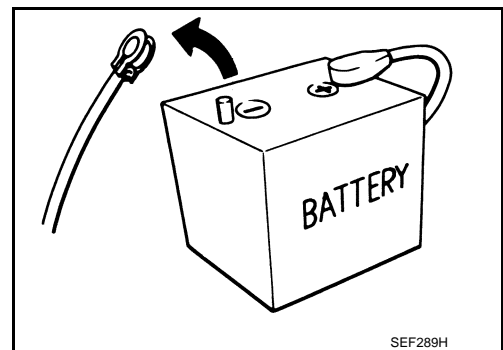

FUEL INJECTOR AND FUEL TUBE

< REMOVAL AND INSTALLATION >

[REGULAR GRADE]

Inspection

INFOID:000000010838691

A

INSPECTION AFTER INSTALLATION

Check for Fuel Leakage

1. Turn ignition switch "ON" (with the engine stopped). With fuel pressure applied to fuel piping, check that there is no fuel leakage at connection points.

NOTE:

Use mirrors for checking at points out of clear sight.

2. Start the engine. With engine speed increased, check that again that there is no fuel leakage at connection points.

CAUTION:

Never touch the engine immediately after it is stopped because the engine is extremely hot.

EM

C

D

E

F

G

H

I

J

K

L

M

N

O

P

CAMSHAFT

< UNIT DISASSEMBLY AND ASSEMBLY >

[REGULAR GRADE]

- **Prevent splashing by using a shop cloth to prevent engine oil from being splashed to engine and vehicle. Especially, be careful no to apply engine oil to rubber parts of drive belt, engine mounting insulator, etc. Wipe engine oil off immediately if it is splashed.**
5. Perform the following inspection if engine oil does not come out from intake valve timing control solenoid valve oil hole of the cylinder head.
 - Remove oil filter, and then clean it. Refer to [EM-56, "Exploded View"](#).
 - Clean oil groove between oil strainer and intake valve timing control solenoid valve. Refer to [LU-2, "Engine Lubrication System"](#).
 6. Remove components between intake valve timing control solenoid valve and camshaft sprocket (INT), and then check each oil groove for clogging.
 - Clean oil groove if necessary. Refer to [LU-2, "Engine Lubrication System"](#).
 7. After inspection, install removed parts in the reverse order.

Inspection for Leakage

The following are procedures for checking fluid leakage, lubricant leakage.

- Before starting engine, check oil/fluid levels including engine coolant and engine oil. If any are less than the required quantity, fill them to the specified level. Refer to [MA-16, "FOR NORTH AMERICA : Fluids and Lubricants"](#) (FOR NORTH AMERICA) or [MA-17, "FOR MEXICO : Fluids and Lubricants"](#) (EXCEPT FOR NORTH AMERICA).
- Follow the procedure below to check for fuel leakage.
 - Turn ignition switch to the "ON" position (with engine stopped). With fuel pressure applied to fuel piping, check for fuel leakage at connection points.
 - Start engine. With engine speed increased, check again for fuel leakage at connection points.
- Run engine to check for unusual noise and vibration.

NOTE:

If hydraulic pressure inside chain tensioner drops after removal/installation, slack in guide may generate a pounding noise during and just after the engine start. However, this does not indicate a malfunction. The noise will stop after hydraulic pressure rises.

- Warm up engine thoroughly to check that there is no leakage of fuel, or any oil/fluids including engine oil and engine coolant.
- Bleed air from lines and hoses of applicable lines, such as in cooling system.
- After cooling down engine, again check oil/fluid levels including engine oil and engine coolant. Refill them to the specified level, if necessary.

Summary of the inspection items:

Items		Before starting engine	Engine running	After engine stopped
Engine coolant		Level	Leakage	Level
Engine oil		Level	Leakage	Level
Transmission / transaxle fluid	AT & CVT Models	Leakage	Level / Leakage	Leakage
	MT Models	Level / Leakage	Leakage	Level / Leakage
Other oils and fluids*		Level	Leakage	Level
Fuel		Leakage	Leakage	Leakage

* Power steering fluid, brake fluid, etc.

SECTION **EXL**

EXTERIOR LIGHTING SYSTEM

A
B
C
D
E
F
G
H
I
J
K
L
M
N
O
P

CONTENTS

XENON TYPE		
PRECAUTION	4	
PRECAUTIONS	4	
FOR USA AND CANADA	4	
FOR USA AND CANADA : Precautions for Supplemental Restraint System (SRS) "AIR BAG" and "SEAT BELT PRE-TENSIONER"	4	
FOR USA AND CANADA : Precautions For Xenon Headlamp Service	4	
FOR USA AND CANADA : Precaution for Battery Service	5	
FOR USA AND CANADA : Precautions for Removing Battery Terminal	5	
FOR MEXICO	5	
FOR MEXICO : Precaution for Supplemental Restraint System (SRS) "AIR BAG" and "SEAT BELT PRE-TENSIONER"	5	
FOR MEXICO : Precautions For Xenon Headlamp Service	5	
FOR MEXICO : Precaution for Battery Service	6	
FOR MEXICO : Precautions for Removing Battery Terminal	6	
SYSTEM DESCRIPTION	7	
COMPONENT PARTS	7	
HEADLAMP SYSTEM	7	
HEADLAMP SYSTEM : Component Parts Location	7	
HEADLAMP SYSTEM : Component Description.....	7	
AUTO LIGHT SYSTEM	7	
AUTO LIGHT SYSTEM : Component Parts Location	8	
AUTO LIGHT SYSTEM : Component Description.....	8	
DAYTIME RUNNING LIGHT SYSTEM	8	
DAYTIME RUNNING LIGHT SYSTEM : Component Parts Location	8	
DAYTIME RUNNING LIGHT SYSTEM : Component Description	10	
TURN SIGNAL AND HAZARD WARNING LAMP SYSTEM	10	
TURN SIGNAL AND HAZARD WARNING LAMP SYSTEM : Component Parts Location	10	
TURN SIGNAL AND HAZARD WARNING LAMP SYSTEM : Component Description	10	
PARKING, LICENSE PLATE AND TAIL LAMPS	11	
PARKING, LICENSE PLATE AND TAIL LAMPS : Component Parts Location	11	
PARKING, LICENSE PLATE AND TAIL LAMPS : Component Description	11	
REAR FOG LAMP SYSTEM	11	
REAR FOG LAMP SYSTEM : Component Parts Location	12	
REAR FOG LAMP SYSTEM : Component Description	12	
EXTERIOR LAMP BATTERY SAVER SYSTEM	12	
EXTERIOR LAMP BATTERY SAVER SYSTEM : Component Parts Location	13	
EXTERIOR LAMP BATTERY SAVER SYSTEM : Component Description	13	
SYSTEM	14	
HEADLAMP SYSTEM	14	
HEADLAMP SYSTEM : System Diagram	14	
HEADLAMP SYSTEM : System Description	14	
AUTO LIGHT SYSTEM	15	
AUTO LIGHT SYSTEM : System Diagram	15	
AUTO LIGHT SYSTEM : System Description	15	
DAYTIME RUNNING LIGHT SYSTEM	16	
DAYTIME RUNNING LIGHT SYSTEM : System Diagram	16	

EXL

PARKING, LICENSE PLATE AND TAIL LAMPS SYSTEM

< WIRING DIAGRAM >

[XENON TYPE]

PARKING, LICENSE PLATE AND TAIL LAMPS

12	P	OUTPUT 1
13	BR	INPUT 5
14	G	OUTPUT 2

Connector No.	M63
Connector Name	COMBINATION METER
Connector Type	TH24FW-NH

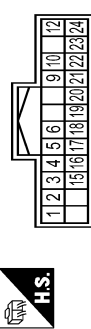

Terminal No.	Color Of Wire	Signal Name [Specification]
1	V	BATTERY POWER SUPPLY
2	O	IGNITION SIGNAL
3	L	VEHICLE SPEED SIGNAL (2-PULSE)
4	V	VEHICLE SPEED SIGNAL (6-PULSE) [For Mexico]
4	Y	VEHICLE SPEED SIGNAL (6-PULSE) [Except for Mexico]
5	B	ILLUMINATION CONTROL SIGNAL
6	R	ROOF STATUS SIGNAL
9	BR	COMMUNICATION SIGNAL (METER-TRIPLE METER)
10	L	COMMUNICATION SIGNAL (TRIPLE METER-METER)
12	G	S-MODE SWITCH SIGNAL
15	L	ACC POWER SUPPLY
16	R	AIR BAG SIGNAL
17	B	GROUND
18	V	AMBIENT SENSOR SIGNAL
19	G	AC AUTO AMP CONNECTION RECOGNITION SIGNAL
20	GR	AMBIENT SENSOR GROUND
21	L	CAN-L
22	P	CAN-L
23	B	GROUND
24	Y	FUEL LEVEL SENSOR GROUND

Connector No.	M118
Connector Name	BCM (BODY CONTROL MODULE)
Connector Type	M03FB-LC



Terminal No.	Color Of Wire	Signal Name [Specification]
1	W	BAT. (FL)
2	W	POWER WINDOW POWER SUPPLY (BAT)
3	Y	POWER WINDOW POWER SUPPLY (IGN)

Connector No.	M119
Connector Name	BCM (BODY CONTROL MODULE)
Connector Type	NS18FW-GS



Terminal No.	Color Of Wire	Signal Name [Specification]
4	R	INTERIOR ROOM LAMP POWER SUPPLY
5	G	PASSENGER DOOR UNLOCK OUTPUT
8	V	ALL DOOR. FUEL LID LOCK OUTPUT
9	G	DRIVER DOOR. FUEL LID UNLOCK OUTPUT
11	BR	BAT (FUSE)
13	B	GROUND
14	R	PUSH-BUTTON (IGNITION SW ILL GND)
15	Y	ACC. IND
17	W	TURN SIGNAL RH (FRONT SIDE)
18	O	TURN SIGNAL LH (FRONT SIDE)
18	P	ROOM LAMP TIMER CONTROL

Connector No.	M122
Connector Name	BCM (BODY CONTROL MODULE)
Connector Type	TH40FB-NH

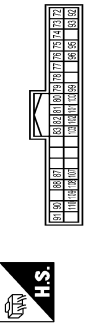

Terminal No.	Color Of Wire	Signal Name [Specification]
72	L	ROOM ANT 2-
72	P	ROOM ANT 2+
74	SB	PASSENGER DOOR ANT-
74	BR	PASSENGER DOOR ANT+
76	V	DRIVER DOOR ANT-
77	LG	DRIVER DOOR ANT+
78	L	ROOM ANT 1-
79	R	ROOM ANT 1+
80	GR	NATS ANT AMP
81	W	NATS ANT AMP
82	R	IGN RELAY (FBI) CONT
83	GR	KYLS ENT RECEIVER (FRONT) COMM
87	BR	COMBI SW INPUT 5
88	V	COMBI SW INPUT 3
90	P	CAN-L
91	L	CAN-H
92	LG	KEY SLOT ILL
93	V	ON IND
95	O	ACC RELAY CONT
96	Y	AT SHIFT SELECTOR POWER SUPPLY
99	R	SHIFT P/CLUTCH PEDAL POS SW
100	GR	PASSENGER DOOR REQUEST SW
101	Y	DRIVER DOOR REQUEST SW
102	O	BLOWER FAN MOTOR RELAY CONT
103	LG	KYLS ENT RECEIVER (FRONT) PWS SUPPLY
107	LG	COMBI SW INPUT 4
108	R	COMBI SW INPUT 1
109	Y	COMBI SW INPUT 2
110	P	HAZARD SW

Connector No.	M123
Connector Name	BCM (BODY CONTROL MODULE)
Connector Type	TH40FG-NH

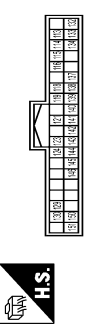

Terminal No.	Color Of Wire	Signal Name [Specification]
113	O	OPTICAL SENSOR
114	R	CLUTCH INTERLOCK SW
115	O	
116	SB	STOP LAMP SW 1
116	P	STOP LAMP SW 2
119	SB	DR DOOR UNLOCK SENSOR
121	R	IGN/FB
123	W	KEY SLOT SW
124	LG	PASSENGER DOOR SW
129	O	TRUNK LID OPENER CANCEL SW
130	L	REAR DEFOGGER SW
132	V	RWS SW & SOFT TOP C/L COMM (Passenger models)
132	Y	POWER WINDOW SW COMM (Coupe models)
133	G	PUSH-BUTTON (IGNITION SW ILL POWER)
134	GR	LOCK IND
137	P	RECEIVER & SENSOR GND
138	V	RECEIVER & SENSOR POWER SUPPLY
139	L	TIRE PRESS RECEIVE COMM
140	G	PIN POSITION
141	Y	SECURITY INDICATOR
142	O	COMBI SW OUTPUT 5
143	P	COMBI SW OUTPUT 1
144	G	COMBI SW OUTPUT 2
145	L	COMBI SW OUTPUT 3
146	SB	COMBI SW OUTPUT 4
150	GR	DRIVER DOOR SW
151	G	REAR WINDOW DEFOGGER RELAY CONT

A
B
C
D
E
F
G
H
I
J
K
M
N
O
P

EXL

REAR COMBINATION LAMP

< REMOVAL AND INSTALLATION >

[XENON TYPE]

REAR COMBINATION LAMP

Exploded View

INFOID:000000010840609

REMOVAL

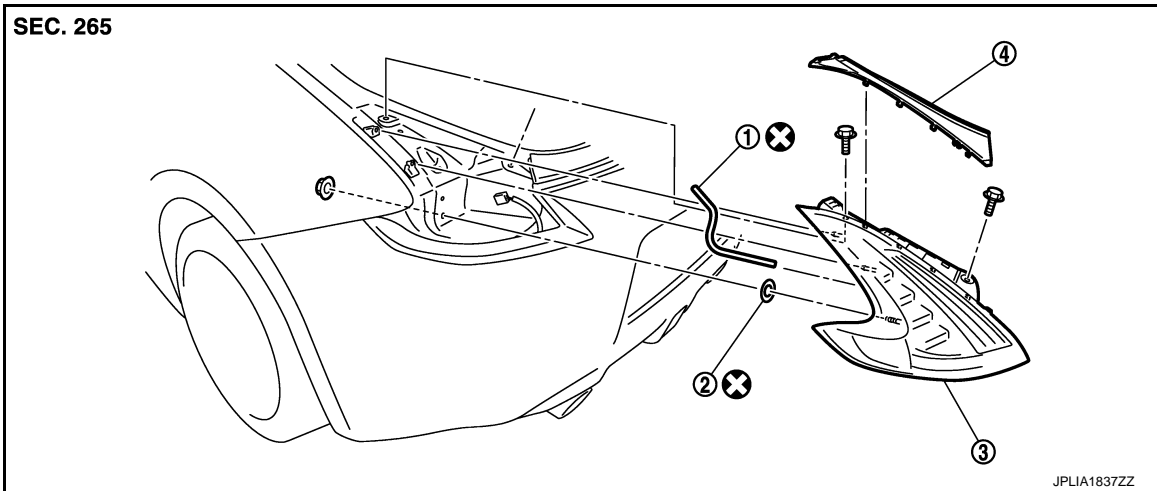

- 1. EPT sealer
- 2. Seal packing
- 3. Rear combination lamp assembly
- 4. Rear combination lamp finisher

⊗ : Always replace after every disassembly.

DISASSEMBLY

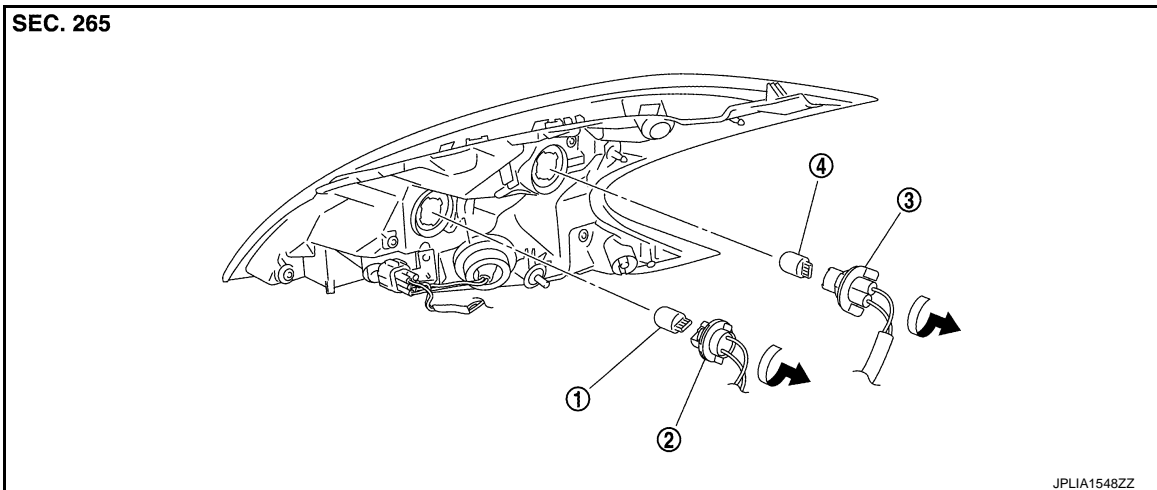

- 1. Rear turn signal lamp bulb
- 2. Rear turn signal lamp bulb socket
- 3. Back-up lamp bulb socket
- 4. Back-up lamp

Removal and Installation

INFOID:000000010840610

CAUTION:
Disconnect the battery negative terminal or remove the fuse.

REMOVAL

1. Remove the rear combination lamp finisher.
2. Remove the luggage side finisher upper / trunk side finisher.
Coupe models: Refer to [INT-31, "Exploded View"](#).
Roadster models: Refer to [INT-75, "Exploded View"](#).
3. Remove the rear combination lamp mounting nut and bolts.

A
B
C
D
E
F
G
H
I
J
K
EXL
M
N
O
P

FRONT PILLAR FINISHER

< REMOVAL AND INSTALLATION >

Installation

Note the following items, and then install in the reverse order of removal.

CAUTION:

- Visually check the clips for deformation and damage during installation. Replace with new ones if necessary.
- When installing front pillar finisher, check that clips are securely fitted in body panel holes, and press them it.

REMOVAL AND INSTALLATION OF FRONT SIDE GLASS RUN ASSEMBLY

Removal

1. Remove front pillar garnish (LH/RH). Refer to [INT-51, "FRONT PILLAR GARNISH : Removal and Installation"](#).
2. Remove fixing clips, and then remove front roof cover.
3. Remove front roof finisher. Refer to [INT-71, "Removal and Installation"](#).
4. Remove front side glass run assembly mounting nuts (A) (LH/RH).

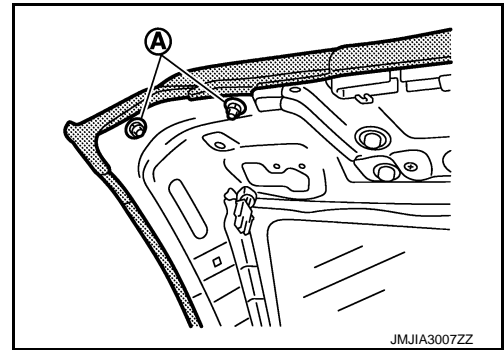

5. Remove front side glass run assembly retainer mounting screws, and then remove body side weather-strip retainer.
6. Remove front pillar finisher fixing clips with remover tool.

 : Clip

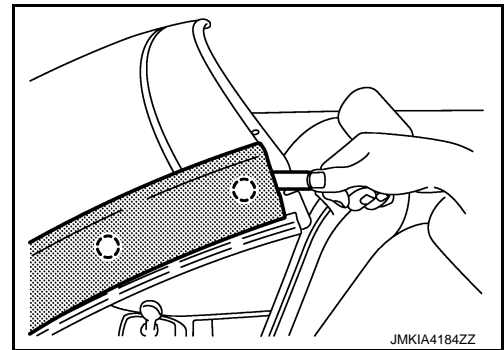

7. Disengage front pillar finisher fixing clip (A).

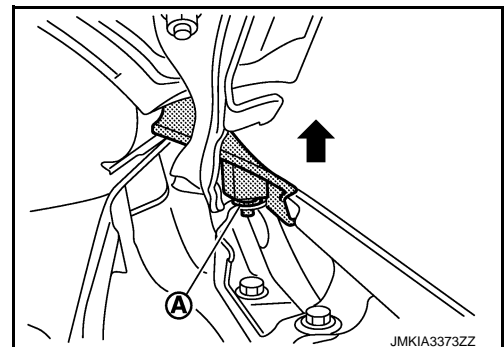

A
B
C
D
E
F
G
H
I
J
EXT
L
M
N
O
P

SERVICE DATA AND SPECIFICATIONS (SDS)

< SERVICE DATA AND SPECIFICATIONS (SDS)

[Nismo 370Z]

SERVICE DATA AND SPECIFICATIONS (SDS)

SERVICE DATA AND SPECIFICATIONS (SDS)

Wheel Alignment

INFOID:000000011144794

Item		Standard	
Camber Degree minute (Decimal degree)	Minimum	-1° 30' (-1.50°)	
	Nominal	-0° 45' (-0.75°)	
	Maximum	0° 00' (0.00°)	
	Left and right difference	0° 33' (0.55°) or less	
Caster Degree minute (Decimal degree)	Minimum	4° 30' (4.50°)	
	Nominal	5° 15' (5.25°)	
	Maximum	6° 00' (6.00°)	
	Left and right difference	0° 39' (0.65°) or less	
Kingpin inclination Degree minute (Decimal degree)	Minimum	7° 00' (7.00°)	
	Nominal	7° 45' (7.75°)	
	Maximum	8° 30' (8.50°)	
Toe-in	Total toe-in Distance	Minimum	In 1 mm (0.04 in)
		Nominal	In 2 mm (0.08 in)
		Maximum	In 3 mm (0.11 in)
	Toe angle (left wheel or right wheel) Degree minute (Decimal Degree)	Minimum	In 0° 03' (0.05°)
		Nominal	In 0° 05' (0.08°)
		Maximum	In 0° 07' (0.11°)

Measure value under unladen* conditions.

*: Fuel, engine coolant and lubricant are full. Spare tire, jack, hand tools and mats are in designated positions.

Ball Joint

INFOID:000000011144795

Item		Standard
Swing torque	Transverse link	0.5 – 3.6 N·m (0.06 – 0.36 kg·m, 5 – 31 in-lb)
	Upper link	0 – 2.0 N·m (0 – 0.20 kg·m, 0 – 17 in-lb)
Measurement on spring balance	Transverse link	7.8 – 56.3 N (0.8 – 5.7 kg, 1.8 – 12.6 lb)
	Upper link	0 – 61.5 N (0 – 6.2 kg, 0 – 13.8 lb)
Rotating torque	Transverse link	0.5 – 3.9 N·m (0.06 – 0.39 kg·m, 5 – 34 in-lb)
Axial end play		0 mm (0 in)

Wheelarch Height

INFOID:000000011144796

Item	Standard
Front (Hf)	704 mm (27.72 in)

CONSULT/GST CHECKING SYSTEM

< BASIC INSPECTION >

[REGULAR GRADE]

GI

B

C

D

E

F

G

H

I

J

K

L

M

N

O

P

CONSULT CHECKING SYSTEM

Connector No.	M122
Connector Name	BCM (BODY CONTROL MODULE)
Connector Type	TH40FE-NH

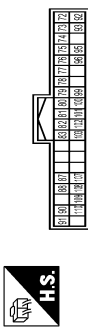

Terminal No.	Color Of Wire	Signal Name [Specification]
72	L	ROOM ANT 2-
73	P	ROOM ANT 2+
74	SB	PASSENGER DOOR ANT-
75	BR	PASSENGER DOOR ANT+
76	V	DRIVER DOOR ANT-
77	LG	DRIVER DOOR ANT+
78	L	ROOM ANT 1-
79	R	ROOM ANT 1+
80	GR	NATS ANT AMP
81	W	NATS ANT AMP
82	R	IGN RELAY (FIB) CONT
83	GR	KYLS ENT RECEIVER (FRONT) COMM
87	BR	COMBI SW INPUT 5
88	V	COMBI SW INPUT 3
90	P	CAN-L
91	L	CAN-H
92	LG	KEY SLOT ILL
93	V	ON IND
95	O	ACC RELAY CONT
99	R	AT SHIFT SELECTOR POWER SUPPLY
100	GR	SHIFT P/CLUTCH PEDAL POS SW
101	Y	PASSENGER DOOR REQUEST SW
102	O	DRIVER DOOR REQUEST SW
103	LG	BLOWER FAN MOTOR RELAY CONT
107	LG	KYLS ENT RECEIVER (FRONT) PWR SUPPLY
108	R	COMBI SW INPUT 1
109	Y	COMBI SW INPUT 4
110	P	COMBI SW INPUT 2
		HAZARD SW

Connector No.	M147
Connector Name	AIR BAG DIAGNOSIS SENSOR UNIT
Connector Type	NE28FY-EX

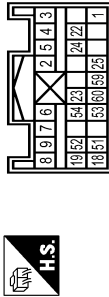

Terminal No.	Color Of Wire	Signal Name [Specification]
1	LG	IGN
2	B	GND
3	Y	DR 1 (+)
4	Y	DR 1 (-) DR 2 (-)
5	Y	DR 2 (+)
6	Y	AS 1 (+)
7	Y	AS 1 (-)
8	Y	AS 2 (+)
9	Y	AS 2 (-)
18	R	ECZS (+)
19	L	ECZS (-)
22	SHIELD	GND
23	R	AIRBAG W/L
24	P	SEAT BELT
25	R	CUTOFF TELLTALE
51	W	SATELLITE RH2 (+)
52	B	SATELLITE RH2 (-)
53	Y	SATELLITE LH2 (+)
54	BR	SATELLITE LH2 (-)
59	L	CAN-H
60	P	CAN-L

REFRIGERANT

< PERIODIC MAINTENANCE >

2. Operate recovery/recycling/recharging equipment, and evacuate air from A/C system for 25 minutes or more.
CAUTION:
Evacuate air for 15 minutes or more if the parts are replaced.
3. Check the airtightness of A/C system for 25 minutes or more. If pressure raises more than the specified level, charge A/C system with approximately 200 g refrigerant and check that there is no refrigerant leakage. Refer to [HA-24, "Leak Test"](#).
CAUTION:
Check the airtightness for 15 minutes or more if the parts are replaced.
4. If parts other than compressor are replaced, fill compressor lubricant according to parts that are replaced.
5. Charge the specified amount of refrigerant to A/C system.
6. Check that A/C system operates normally.
7. Disconnect recovery/recycling/recharging equipment. (Collect the refrigerant from the high-pressure hose and low-pressure hose of recovery/recycling/recharging equipment.)
8. Install A/C service valve cap.
9. Refrigerant charge is complete.

A
B
C
D
E
F
G
H
HA
J
K
L
M
N
O
P

B257B, B257C AMBIENT SENSOR

< DTC/CIRCUIT DIAGNOSIS >

[WITHOUT 7 INCH DISPLAY]

Ambient sensor		—	Continuity
Connector	Terminal		
E76	1	Ground	Not existed

Is the inspection result normal?

- YES >> Replace the A/C auto amp.
- NO >> Repair the harnesses or connectors.

Component Inspection

INFOID:000000010842252

1. CHECK AMBIENT SENSOR

1. Turn the ignition switch OFF.
2. Remove the ambient sensor. Refer to [HAC-87. "Exploded View"](#).
3. Check the resistance between the ambient sensor terminals. Refer to the applicable table for the normal value.

Terminal		Condition	Resistance: kΩ
		Temperature: °C (°F)	
1	2	-15 (5)	12.73
		-10 (14)	9.92
		-5 (23)	7.80
		0 (32)	6.19
		5 (41)	4.95
		10 (50)	3.99
		15 (59)	3.24
		20 (68)	2.65
		25 (77)	2.19
		30 (86)	1.81
		35 (95)	1.51
		40 (104)	1.27
45 (113)	1.07		

Is the inspection result normal?

- YES >> INSPECTION END
- NO >> Replace the ambient sensor.

SUNLOAD SENSOR

< REMOVAL AND INSTALLATION >

[WITHOUT 7 INCH DISPLAY]

SUNLOAD SENSOR

Exploded View

INFOID:000000010842319

1. Sunload sensor

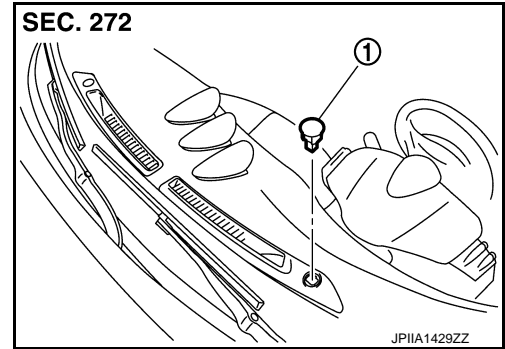

Removal and Installation

INFOID:000000010842320

REMOVAL

Disconnect sunload sensor connector, and then remove sunload sensor.

INSTALLATION

Install in the reverse order of removal.

A
B
C
D
E
F
G
H
J
K
L
M
N
O
P

HAC

MAGNET CLUTCH

< DTC/CIRCUIT DIAGNOSIS >

[WITH 7 INCH DISPLAY]

IPDM E/R		—	Continuity
Connector	Terminal		
E7	48	Ground	Not existed

Is the inspection result normal?

- YES >> GO TO 5.
- NO >> Repair the harnesses and connectors.

5. CHECK FUSE

Check 10A fuse (No. 49, located in the IPDM E/R).

NOTE:

Refer to [PG-101, "Fuse, Connector and Terminal Arrangement"](#).

Is the inspection result normal?

- YES >> Replace IPDM E/R.
- NO >> Replace the fuse after repairing the applicable circuit.

6. CHECK SELF-DIAGNOSIS RESULT CHECK

④ With CONSULT

1. Perform the "SELF-DIAGNOSIS".
2. Check if any DTC is detected in the self-diagnostic results.

NOTE:

If DTC is displayed along with DTC "U1000" or "U1010", first diagnose the DTC "U1000" or "U1010". Refer to [HAC-118, "DTC Logic"](#) or [HAC-119, "DTC Logic"](#).

Is any DTC displayed?

- YES >> Perform the diagnosis that is applicable to the sensor and actuator. Refer to [HAC-161, "DTC Index"](#).
- NO >> GO TO 7.

7. CHECK A/C AUTO AMP. OUTPUT SIGNAL

④ With CONSULT

1. Perform the "DATA MONITOR" of HVAC. Refer to [HAC-150, "Reference Value"](#).
2. Check A/C ON signal and blower fan ON switch signal.

Monitor item	Condition	Status
COMP REQ SIG	A/C switch: OFF	Off
	A/C switch: ON	On
FAN REQ SW	Fan control dial: OFF	Off
	Fan control dial: ON	On

Is the inspection result normal?

- YES >> GO TO 8.
- NO >> Replace A/C auto amp.

8. CHECK REFRIGERANT PRESSURE SENSOR

Check the refrigerant pressure sensor. Refer to [EC-527, "Diagnosis Procedure"](#).

Is the inspection result normal?

- YES >> INSPECTION END
- NO >> Repair or replace the malfunctioning parts.

COMPONENT PARTS

< SYSTEM DESCRIPTION >

[COUPE]

SYSTEM DESCRIPTION

COMPONENT PARTS

INTERIOR ROOM LAMP CONTROL SYSTEM

INTERIOR ROOM LAMP CONTROL SYSTEM : Component Parts Location

INFOID:0000000010837494

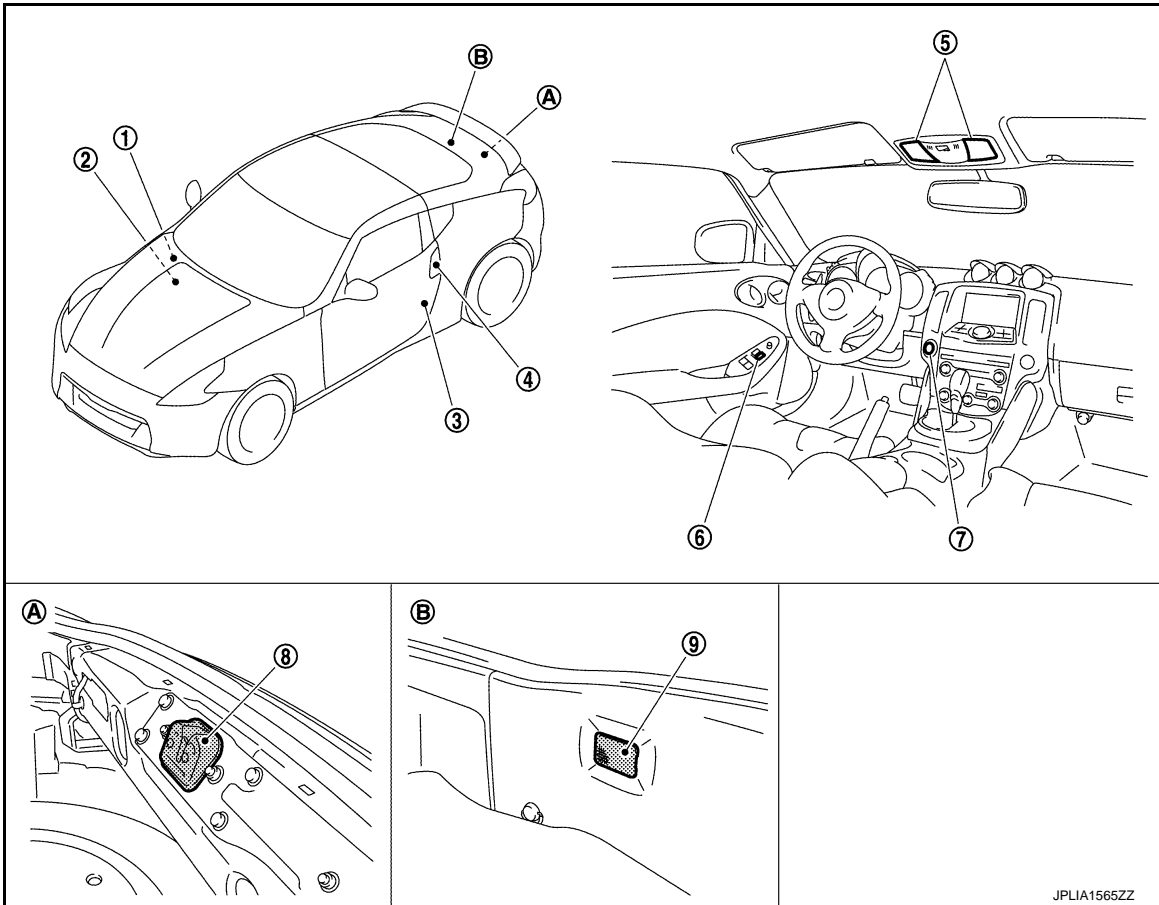

- | | | |
|--|---|--------------------------------|
| 1. Remote keyless entry receiver
Refer to DLK-21, "Remote Keyless Entry Receiver" . | 2. BCM
Refer to BCS-10, "Component Parts Location" . | 3. Door switch |
| 4. • Key cylinder switch
• Request switch | 5. Map lamp | 6. Door lock and unlock switch |
| 7. Push-button ignition switch
(Push-button ignition switch illumination) | 8. Back door switch | 9. Luggage room lamp |
| A. Back door lock assembly | B. Luggage room | |

INTERIOR ROOM LAMP CONTROL SYSTEM : Component Description

INFOID:0000000010837495

Part	Description
BCM	<ul style="list-style-type: none"> Activates the interior room lamp timer depending on the vehicle condition to turn the interior room lamp ON/OFF. Turns the luggage room lamp ON /OFF according to the luggage room lamp switch status.
Remote keyless entry receiver	Transmits the lock/unlock signal to BCM.

CLICK HERE TO **DOWNLOAD** THE COMPLETE MANUAL

- Thank you very much for reading the preview of the manual.
- You can download the complete manual from: www.heydownloads.com by clicking the link below



- Please note: If there is no response to CLICKING the link, please download this PDF first and then click on it.

CLICK HERE TO **DOWNLOAD** THE COMPLETE MANUAL

SYSTEM

[ROADSTER]

< SYSTEM DESCRIPTION >

- BCM judges the vehicle condition with the following items. It activates the interior room timer.
 - Ignition switch status
 - Door switch signal (ALL)
 - Door lock/unlock signal (Remote keyless entry receiver, each door request switch, key cylinder switch, door lock and unlock switch)

NOTE:

Each function of interior room lamp timer can be set by CONSULT. Refer to [INL-70. "INT LAMP : CONSULT Function \(BCM - INT LAMP\) \(Roadster Models\)"](#).

Interior Room Lamp ON Operation

- BCM always turns the interior room lamp ON when any door opens.
- BCM activates the interior room timer in any of the following conditions to turn the interior room lamp ON for a period of time.
 - Any door opens before all doors close.
 - Ignition switch is turned ON → OFF.
 - Any door unlock signal is detected when all doors close with ignition switch OFF.

NOTE:

Restart the timer if new condition is input during the timer operating time.

Interior Room Lamp OFF Operation

BCM stops the timer in any of the following conditions to turns the interior room lamp OFF.

- The timer operating time is expired.
- Ignition switch position is other than OFF with all doors close.
- Any door lock operation is detected with all doors close.

TRUNK ROOM LAMP CONTROL

BCM controls the trunk room lamp (ground-side) to turn ON with the trunk room lamp switch ON.

PUSH-BUTTON IGNITION SWITCH ILLUMINATION CONTROL

Push-button Ignition Switch Illumination Basic Operation

- BCM provides the power supply and the ground to turn the push-button ignition switch illumination ON.
- BCM cuts the ground supply while the each illumination (tail lamp) ON. BCM switches to the ground control with the meter illumination control function.

Push-button Ignition Switch Illumination ON Operation

BCM turns the push-button ignition switch illumination ON in the following conditions.

- Ignition switch ON
- Each illumination (tail lamp) ON
- Any of the following conditions with ignition switch OFF
 - Engine start permission is entered.
 - Intelligent Key inserted into the key slot.
 - Driver door is LOCK → UNLOCK.
 - Driver door is open.

Push-button Ignition Switch Illumination OFF Operation

BCM turns the push-button ignition switch illumination OFF in any of the following conditions.

- The push-button ignition switch illumination ON conditions do not satisfy.
- All of the following conditions with ignition switch OFF
 - Each illumination (tail lamp) OFF
 - The push-button ignition switch illumination ON conditions do not change (15 seconds after the ignition switch OFF) or the driver door is UNLOCK → LOCK.

INTERIOR ROOM LAMP BATTERY SAVER SYSTEM

HEADLINING	28	DOOR FINISHER	47
Exploded View	28	Exploded View	47
Removal and Installation	28	Removal and Installation	48
LUGGAGE FLOOR TRIM	31	BODY SIDE TRIM	51
Exploded View	31	Exploded View	51
Removal and Installation	32	FRONT PILLAR GARNISH	51
BACK DOOR TRIM	33	FRONT PILLAR GARNISH : Removal and Instal-	
Exploded View	33	lation	51
Removal and Installation	33	KICKING PLATE INNER	52
COUPE (Nismo 370Z)		KICKING PLATE INNER : Removal and Installa-	
SPEC CHANGE INFORMATION	35	tion	52
REAR TRIM	35	KICKING PLATE OUTER	53
Serialized Authenticity Plate	35	KICKING PLATE OUTER : Removal and Installa-	
ROADSTER		tion	53
PRECAUTION	36	DASH SIDE FINISHER	53
PRECAUTIONS	36	DASH SIDE FINISHER : Removal and Installation	
FOR USA AND CANADA	36	... 53	
FOR USA AND CANADA : Precautions for Sup-		BODY SIDE WELT	53
plemental Restraint System (SRS) "AIR BAG" and		BODY SIDE WELT : Removal and Installation	53
"SEAT BELT PRE-TENSIONER"	36	REAR SIDE FINISHER	54
FOR USA AND CANADA : Precaution for Battery		REAR SIDE FINISHER : Removal and Installation	
Service	36	... 54	
FOR USA AND CANADA : Precaution for Proce-		REAR TRIM	55
dure without Cowl Top Cover	36	Exploded View	55
FOR USA AND CANADA : Precaution for Work ...	37	REAR BOARD PARCEL SHELF SIDE FINISHER ...	56
FOR MEXICO	37	REAR BOARD PARCEL SHELF SIDE FINISHER	
FOR MEXICO : Precaution for Supplemental Re-		: Removal and Installation	56
straint System (SRS) "AIR BAG" and "SEAT BELT		GUARD FRAME PROTECTOR ASSEMBLY	56
PRE-TENSIONER"	37	GUARD FRAME PROTECTOR ASSEMBLY : Re-	
FOR MEXICO : Precaution for Battery Service	37	moval and Installation	56
FOR MEXICO : Precaution for Procedure without		GUARD FRAME PLATE ASSEMBLY	57
Cowl Top Cover	37	GUARD FRAME PLATE ASSEMBLY : Removal	
FOR MEXICO : Precaution for Work	37	and Installation	57
Precautions for Removing Battery Terminal	38	STORAGE LID DEFLECTOR	58
PREPARATION	39	STORAGE LID DEFLECTOR : Removal and In-	
PREPARATION	39	stallation	58
Special Service Tools	39	REAR PARCEL SHELF FINISHER COVER	59
Commercial Service Tools	39	REAR PARCEL SHELF FINISHER COVER : Re-	
CLIP LIST	40	moval and Installation	59
Clip List	40	REAR PARCEL SHELF COVER	60
SYMPTOM DIAGNOSIS	41	REAR PARCEL SHELF COVER : Removal and	
SQUEAK AND RATTLE TROUBLE DIAG-		Installation	60
NOSES	41	REAR PARCEL SHELF FINISHER HOLDER	60
Work Flow	41	REAR PARCEL SHELF FINISHER HOLDER :	
Inspection Procedure	43	Removal and Installation	60
Diagnostic Worksheet	45	SEATBACK CENTER FINISHER	61
REMOVAL AND INSTALLATION	47	SEATBACK CENTER FINISHER : Removal and	
		Installation	61

REAR TRIM

[ROADSTER]

< REMOVAL AND INSTALLATION >

6. Remove storage lid deflector (1) mounting nuts (A) and bolts (B), and then remove storage lid deflector.

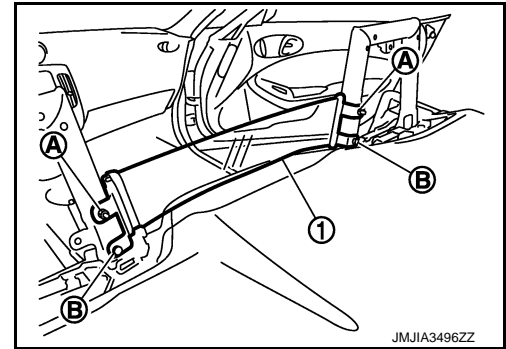

7. Disengage rear parcel shelf finisher cover fixing pawls with a remover tool (A) and then remove rear parcel shelf finisher cover.

NOTE:

- Remove according to the steps indicated in the figure to avoid damaging the fixing pawls.
- Apply protective tape (B) around rear parcel shelf finisher cover to protect the painted surface from damage.

 : Pawl

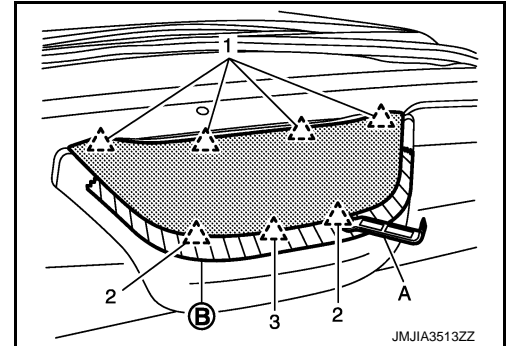

INSTALLATION

Note the following item, and install in the reverse order of removal.

CAUTION:

Check that all pawls are securely fitted in panel holes on body when installing, and then press them in.

REAR PARCEL SHELF COVER

REAR PARCEL SHELF COVER : Removal and Installation

INFOID:0000000110838052

REMOVAL

1. Remove rear parcel shelf cover LH with remover tool as shown in the figure.

 : Clip

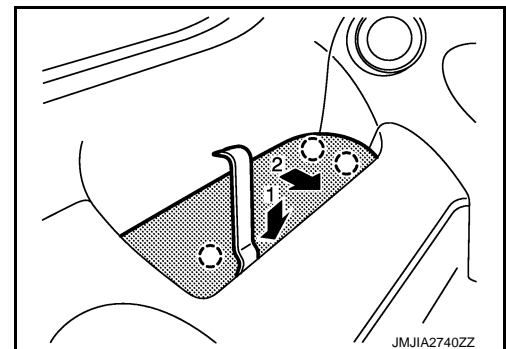

2. Remove rear parcel shelf finisher holder. Refer to [INT-60. "REAR PARCEL SHELF FINISHER HOLDER : Removal and Installation"](#).
3. Remove rear parcel shelf cover RH with a remover tool.

INSTALLATION

Note the following items, and install in the reverse order of removal.

CAUTION:

Check that clips are securely fitted in panel holes on body when installing, and then press them in.

REAR PARCEL SHELF FINISHER HOLDER

REAR PARCEL SHELF FINISHER HOLDER : Removal and Installation

INFOID:0000000110838053

REMOVAL

TROUBLE DIAGNOSIS

Condition of Error Detection

INFOID:000000010838826

DTC (e.g. U1000 and U1001) of CAN communication is indicated on SELF-DIAG RESULTS on CONSULT if a CAN communication signal is not transmitted or received between units for 2 seconds or more.

CAN COMMUNICATION SYSTEM ERROR

- CAN communication line open (CAN-H, CAN-L, or both).
- CAN communication line short (ground, between CAN communication lines, other harnesses).
- Error of CAN communication control circuit of the unit connected to CAN communication line.

WHEN DTC OF CAN COMMUNICATION IS INDICATED EVEN THOUGH CAN COMMUNICATION SYSTEM IS NORMAL

- Removal/installation of parts: Error may be detected when removing and installing CAN communication unit and related parts while turning the ignition switch ON. (A DTC except for CAN communication may be detected.)
- Fuse blown out (removed): CAN communication of the unit may cease.
- Voltage drop: Error may be detected if voltage drops due to discharged battery when turning the ignition switch ON (Depending on the control unit which carries out CAN communication).
- Error may be detected if the power supply circuit of the control unit, which carries out CAN communication, malfunctions (Depending on the control unit which carries out CAN communication).
- Error may be detected if reprogramming is not completed normally.

CAUTION:

CAN communication system is normal if DTC of CAN communication is indicated on SELF-DIAG RESULTS of CONSULT under the above conditions. Erase the memory of the self-diagnosis of each unit.

Symptom When Error Occurs in CAN Communication System

INFOID:000000010838827

In CAN communication system, multiple units mutually transmit and receive signals. Each unit cannot transmit and receive signals if any error occurs on CAN communication line. Under this condition, multiple control units related to the root cause malfunction or go into fail-safe mode.

ERROR EXAMPLE

NOTE:

- Each vehicle differs in symptom of each unit under fail-safe mode and CAN communication line wiring.
- Refer to [LAN-20, "Abbreviation List"](#) for the unit abbreviation.

Example: TCM branch line open circuit

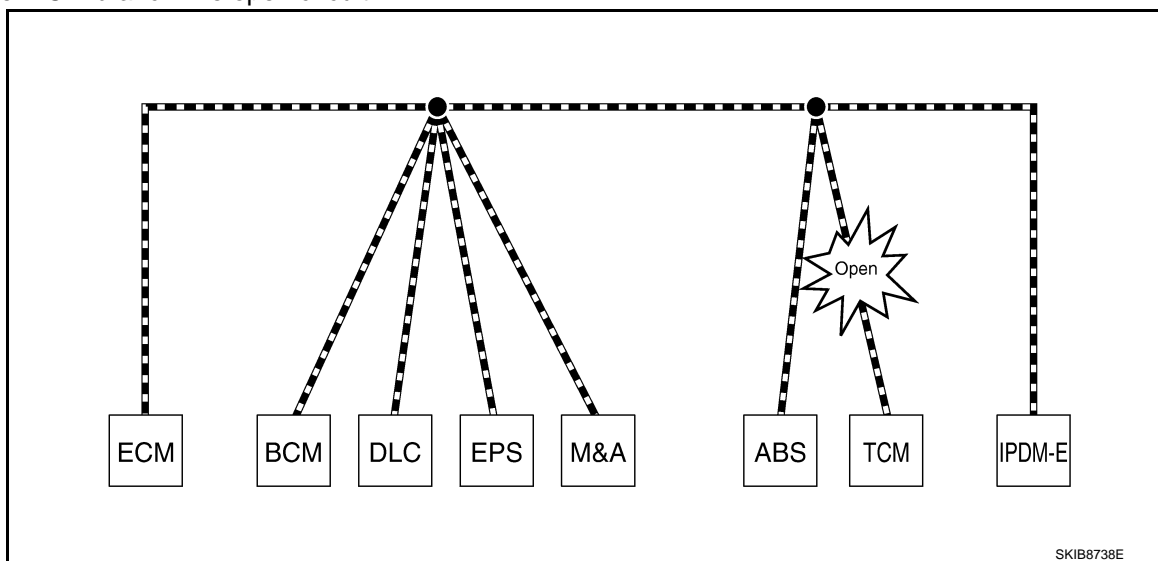

Unit name	Symptom
ECM	Engine torque limiting is affected, and shift harshness increases.
BCM	Reverse warning chime does not sound.

A
B
C
D
E
F
G
H
I
J
K
L
N
O
P

LAN

ECM BRANCH LINE CIRCUIT

< DTC/CIRCUIT DIAGNOSIS >

[CAN SYSTEM (TYPE 2)]

ECM BRANCH LINE CIRCUIT

Diagnosis Procedure

INFOID:000000011372682

1. CHECK CONNECTOR

1. Turn the ignition switch OFF.
2. Disconnect the battery cable from the negative terminal.
3. Check the terminals and connectors of the ECM for damage, bend and loose connection (unit side and connector side).

Is the inspection result normal?

- YES >> GO TO 2.
NO >> Repair the terminal and connector.

2. CHECK HARNESS FOR OPEN CIRCUIT

1. Disconnect the connector of ECM.
2. Check the resistance between the ECM harness connector terminals.

ECM harness connector			Resistance (Ω)
Connector No.	Terminal No.		
M107	114	113	Approx. 108 – 132

Is the measurement value within the specification?

- YES >> GO TO 3.
NO >> Repair the ECM branch line.

3. CHECK POWER SUPPLY AND GROUND CIRCUIT

Check the power supply and the ground circuit of the ECM. Refer to [EC-173, "Diagnosis Procedure"](#).

Is the inspection result normal?

YES (Present error)>>Replace the ECM. Refer to [EC-17, "ADDITIONAL SERVICE WHEN REPLACING CONTROL UNIT \(ECM\) : Special Repair Requirement"](#).

YES (Past error)>>Error was detected in the ECM branch line.

NO >> Repair the power supply and the ground circuit.

A
B
C
D
E
F
G
H
I
J
K
L

LAN

N
O
P

BCM BRANCH LINE CIRCUIT

< DTC/CIRCUIT DIAGNOSIS >

[CAN SYSTEM (TYPE 22)]

BCM BRANCH LINE CIRCUIT

Diagnosis Procedure

INFOID:000000011372742

1. CHECK CONNECTOR

1. Turn the ignition switch OFF.
2. Disconnect the battery cable from the negative terminal.
3. Check the terminals and connectors of the BCM for damage, bend and loose connection (unit side and connector side).

Is the inspection result normal?

- YES >> GO TO 2.
NO >> Repair the terminal and connector.

2. CHECK HARNESS FOR OPEN CIRCUIT

1. Disconnect the connector of BCM.
2. Check the resistance between the BCM harness connector terminals.

BCM harness connector			Resistance (Ω)
Connector No.	Terminal No.		
M122	91	90	Approx. 54 – 66

Is the measurement value within the specification?

- YES >> GO TO 3.
NO >> Repair the BCM branch line.

3. CHECK POWER SUPPLY AND GROUND CIRCUIT

Check the power supply and the ground circuit of the BCM. Refer to [BCS-53, "Diagnosis Procedure"](#).

Is the inspection result normal?

- YES (Present error)>>Replace the BCM. Refer to [BCS-106, "Exploded View"](#).
YES (Past error)>>Error was detected in the BCM branch line.
NO >> Repair the power supply and the ground circuit.

A
B
C
D
E
F
G
H
I
J
K
L

LAN

N
O
P

GENERAL MAINTENANCE

< PERIODIC MAINTENANCE >

[REGULAR GRADE]

Item		Reference page
Seats	Check seat position controls such as seat adjusters, seatback recliner, etc. to make sure they operate smoothly and that all latches lock securely in every position. Check that the head restraints move up and down smoothly and that the locks (if equipped) hold securely in all latched positions. Check that the latches lock securely for folding-down rear seatbacks.	—
Seat belts	Check that all parts of the seat belt system (e.g. buckles, anchors, adjusters and retractors) operate properly and smoothly and are installed securely. Check the belt webbing for cuts, fraying, wear or damage.	MA-44
Accelerator pedal	Check the pedal for smooth operation and make sure the pedal does not catch or require uneven effort. Keep the floor mats away from the pedal.	—
Brakes	Check that the brake does not pull the vehicle to one side when applied.	—
Brake pedal and booster	Check the pedal for smooth operation and make sure it has the proper distance under it when depressed fully. Check the brake booster function. Be sure to keep the floor mats away from the pedal.	BR-9 BR-15
Clutch pedal	Make sure the pedal operates smoothly and check that it has the proper free play.	CL-8
Parking brake	Check that the lever or the pedal has the proper travel and make sure that the vehicle is held securely on a fairly steep hill when only the parking brake is applied.	PB-4
Automatic transmission "Park" mechanism	Check that the lock release button on the selector lever operates properly and smoothly. On a fairly steep hill check that the vehicle is held securely with the selector lever in the P (Park) position without applying any brakes.	—

UNDER THE HOOD AND VEHICLE

The maintenance items listed here should be checked periodically (e.g. each time you check the engine oil or refuel).

Item		Reference page
Windshield washer fluid	Check that there is adequate fluid in the tank.	—
Engine coolant level	Check the coolant level when the engine is cold.	MA-20
Radiator and hoses	Check the front of the radiator and clean off any dirt, insects, leaves, etc., that may have accumulated. Make sure the hoses have no cracks, deformation, deterioration or loose connections.	MA-25
Brake and clutch fluid levels	Make sure that the brake and clutch fluid level(s) are(is) between the "MAX" and "MIN" line(s) on the reservoir(s).	MA-40 MA-33
Battery	Check the fluid level in each cell. It should be between the "MAX" and "MIN" lines. Vehicles operated in high temperatures or under severe conditions require frequent checks of the battery fluid level.	PG-3
Engine drive belts	Make sure that no belt is frayed, worn, cracked or oily.	MA-20
Engine oil level	Check the level on the oil level gauge after parking the vehicle on a level spot and turning off the engine.	LU-7
Power steering fluid level and lines	Check the level on the dipstick with the engine off. Check the lines for improper attachment, leaks, cracks, etc.	MA-42
Exhaust system	Make sure there are no loose supports, cracks or holes. If the sound of the exhaust seems unusual or there is a smell of exhaust fumes, immediately locate the trouble and correct it.	MA-30
Underbody	The underbody is frequently exposed to corrosive substances such as those used on icy roads or to control dust. It is very important to remove these substances, otherwise rust will form on the floor pan, frame, fuel lines and around the exhaust system. At the end of winter, the underbody should be thoroughly flushed with plain water, being careful to clean those areas where mud and dirt can easily accumulate.	—
Fluid leaks	Check under the vehicle for fuel, oil, water or other fluid leaks after the vehicle has been parked for a while. Water dripping from the air conditioner after use is normal. If you should notice any leaks or gasoline fumes are evident, check for the cause and correct it immediately.	—

FOR MEXICO

AUTO ANTI-DAZZLING INSIDE MIRROR SYSTEM

< DTC/CIRCUIT DIAGNOSIS >

INSIDE MIRROR

Connector No.	M1
Connector Name	FUSE BLOCK (J/B)
Connector Type	NS06FW-M2

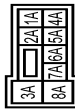

Terminal No.	Color Of Wire	Signal Name [Specification]
1A	V	-
2A	G	-
3A	L	-
4A	P	-
5A	L	-
6A	Y	-
7A	BR	-
8A	L	-

Connector No.	M2
Connector Name	FUSE BLOCK (J/B)
Connector Type	NS10FW-CS

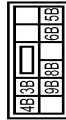

Terminal No.	Color Of Wire	Signal Name [Specification]
3B	P	-
4B	G	-
5B	O	-
6B	Y	-
8B	R	-
9B	SB	-

Connector No.	M18
Connector Name	WIRE TO WIRE
Connector Type	TH12MW-NH



Terminal No.	Color Of Wire	Signal Name [Specification]
1	B	-
2	W	-
3	R	-
4	R	-
5	P	-
6	P	-
7	SHIELD	-
8	R	-
9	G	-
10	B	-
11	G	-
12	Y	-

Connector No.	M106
Connector Name	WIRE TO WIRE
Connector Type	TH16MW-NH



Terminal No.	Color Of Wire	Signal Name [Specification]
4	W	-
5	R	-
6	B	-
7	P	-
8	R	-
9	B	-
10	B	-
11	B	-
12	G	-

Terminal No.	13	Y	-
Terminal No.	14	SHIELD	-
Terminal No.	15	R	-
Terminal No.	16	G	-

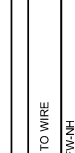

Connector No.	R1
Connector Name	WIRE TO WIRE
Connector Type	TH16FW-NH



Terminal No.	Color Of Wire	Signal Name [Specification]
4	W	-
5	R	-
6	B	-
7	P	-
8	R	-
11	B	-
12	Y	-
13	G	-
14	SHIELD	-
15	R	-
16	G	-

Connector No.	R6
Connector Name	AUTO ANTI-DAZZLING INSIDE MIRROR
Connector Type	TH10FB-NH

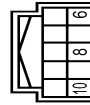

Terminal No.	6	B/R	-
Terminal No.	8	B/W	-
Terminal No.	10	B/Y	-



Connector No.	R11
Connector Name	WIRE TO WIRE
Connector Type	TH12FW-NH

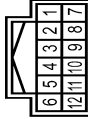

Terminal No.	Color Of Wire	Signal Name [Specification]
1	SB	-
2	B	-
3	R	-
4	B	-
5	V	-
6	R	-
7	SHIELD	-
8	R	-
9	G	-
10	B	-
11	G	-
12	Y	-

TRANSMISSION ASSEMBLY

NOTE:

1st baulk ring has three spaces that four gear tooth is missing and 2nd baulk ring has three spaces that two gear teeth are missing.

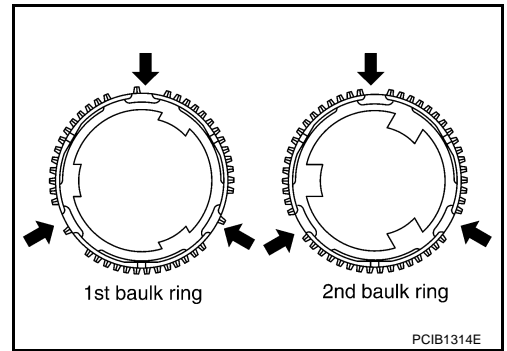

A
B
MT
D

8. Using a support ring and a press to press fit the 1st gear bushing.

Tool number : ST27861000 (—)

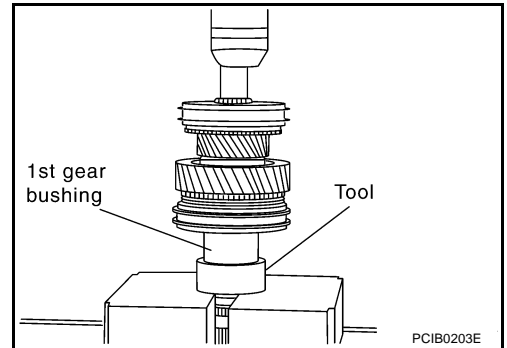

E
F
G

9. Install 1st outer baulk ring, 1st synchronizer cone, 1st inner baulk ring, 1st needle bearing and 1st main gear on the main shaft and then using the inserter and a press to press fit the 3rd main gear.

Tool number : ST30022000 (—)

CAUTION:

- Do not reuse 3rd main gear.
- Replace 1st outer baulk ring, 1st synchronizer cone and 1st inner baulk ring as a set.

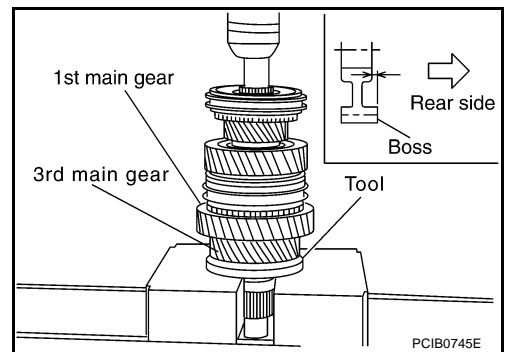

H
I
J
K

10. Install 3rd-4th main spacer on the main shaft and then using the inserter and a press to press fit the 4th main gear.

Tool number : ST30022000 (—)

CAUTION:

- Do not reuse 4th main gear.
- When installing, set boss to rear side.

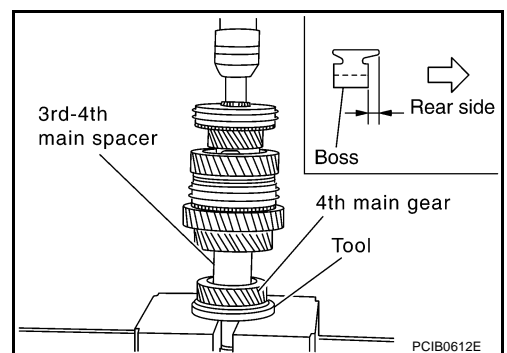

L
M

11. Using the inserter and a press to press fit the main shaft bearing onto the main shaft.

Tool number : ST30911000 (—)

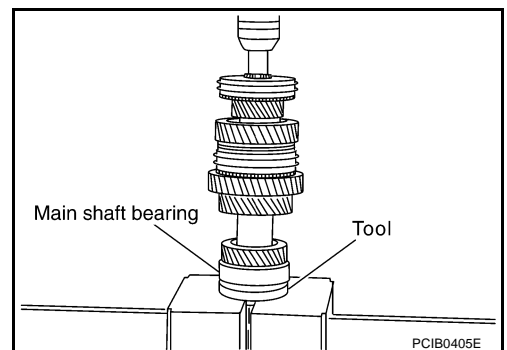

B2201 COMMUNICATION ERROR 1

< DTC/CIRCUIT DIAGNOSIS >

[REGULAR GRADE]

Terminals		Voltage (Approx.)
(+)	(-)	
Combination meter		5 V
Connector	Terminal	
M53	10	

Is the inspection result normal?

YES >> GO TO 4.

NO >> Replace combination meter.

4. CHECK TRIPLE METER OUTPUT VOLTAGE

1. Turn ignition switch OFF.
2. Disconnect combination meter connector.
3. Connect triple meter connector.
4. Turn ignition switch ON.
5. Check voltage between triple meter harness connector and ground.

Terminals		Voltage (Approx.)
(+)	(-)	
Triple meter		5 V
Connector	Terminal	
M242	4	

Is the inspection result normal?

YES >> INSPECTION END

NO >> Replace triple meter.

A
B
C
D
E
F
G
H
I
J
K
L
M
O
P

MWI

NORMAL OPERATING CONDITION

< SYMPTOM DIAGNOSIS >

[REGULAR GRADE]

NORMAL OPERATING CONDITION INFORMATION DISPLAY

INFORMATION DISPLAY : Description

INFOID:0000000010838386

AMBIENT AIR TEMPERATURE

The displayed ambient air temperature on the information display may differ from the actual temperature because it is a corrected value calculated from the ambient sensor signal by the combination meter. Refer to [MWI-27, "INFORMATION DISPLAY : System Description"](#) for details on the correction process.

POSSIBLE DRIVING DISTANCE

The calculated possible driving distance may differ from the actual distance to empty if the refueling amount is approximately 15 ℓ (4 US gal, 3-1/4 Imp gal) or less. This is because the refuel control (moves the fuel gauge needle quicker than normal judging that the driver is refueling the vehicle) is not performing.

A
B
C
D
E
F
G
H
I
J
K
L
M
O
P

MWI

IPDM E/R (INTELLIGENT POWER DISTRIBUTION MODULE ENGINE ROOM)

[IPDM E/R]

< REMOVAL AND INSTALLATION >

4. Remove the IPDM E/R cover A (1) while pressing the pawls (A) at the lower end of the IPDM E/R cover A.
5. Disconnect the harness connector and remove the IPDM E/R (2).
6. Remove the IPDM E/R cover B.

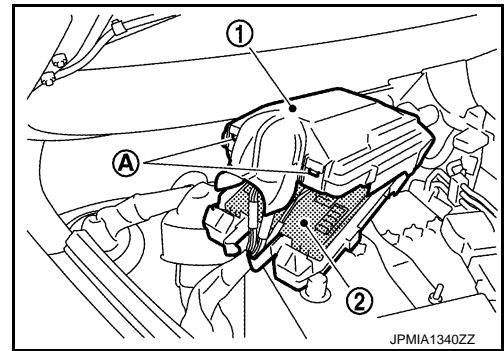



INSTALLATION

Install in the reverse order of removal.

BCM (BODY CONTROL MODULE)

< ECU DIAGNOSIS INFORMATION >

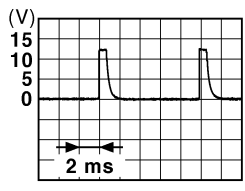
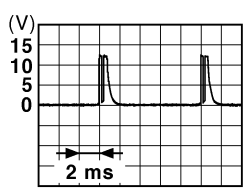
[POWER DISTRIBUTION SYSTEM]

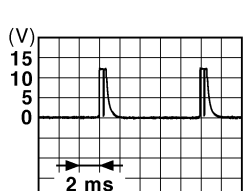
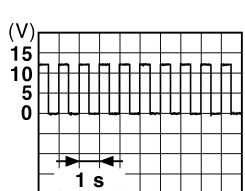
Terminal No. (Wire color)		Description		Condition	Value (Approx.)
		Signal name	Input/ Output		
+	-				
88 (V)	Ground	Combination switch INPUT 3	Input	Combination switch	All switches OFF (Wiper intermittent dial 4) <div style="text-align: right;">  <p style="font-size: small; margin: 0;">1.4 V</p> </div>
					Lighting switch HI (Wiper intermittent dial 4) <div style="text-align: right;">  <p style="font-size: small; margin: 0;">1.3 V</p> </div>
					Lighting switch 2ND (Wiper intermittent dial 4) <div style="text-align: right;">  <p style="font-size: small; margin: 0;">1.3 V</p> </div>
					Any of the conditions below with all switches OFF <ul style="list-style-type: none"> • Wiper intermittent dial 1 • Wiper intermittent dial 2 • Wiper intermittent dial 3 <div style="text-align: right;">  <p style="font-size: small; margin: 0;">1.3 V</p> </div>
90 (P)	Ground	CAN-L	Input/ Output	—	—
91 (L)	Ground	CAN-H	Input/ Output	—	—
92 (LG)	Ground	Key slot illumination	Output	Key slot illumina- tion	OFF <div style="text-align: right;">  <p style="font-size: small; margin: 0;">6.5 V</p> </div>
					ON <div style="text-align: right;"> <p style="margin: 0;">12 V</p> </div>
93 (V)	Ground	ON indicator lamp	Output	Ignition switch	OFF (LOCK indicator is not illuminated) <div style="text-align: right;"> <p style="margin: 0;">Battery voltage</p> </div>
					ON <div style="text-align: right;"> <p style="margin: 0;">0 V</p> </div>

POWER SUPPLY ROUTING CIRCUIT

< DTC/CIRCUIT DIAGNOSIS >

[POWER SUPPLY&GROUND CIRCUIT]

BATTERY POWER SUPPLY

Connector No.	M178
Connector Name	CIRCUIT BREAKER
Connector Type	M02FW-LC



Terminal No.	Color Of Wire	Signal Name [Specification]
1	P	-
2	L	-

Connector No.	M84
Connector Name	AV CONTROL UNIT
Connector Type	TH18FW-CS2

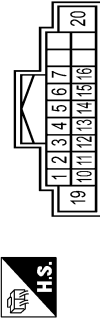

Terminal No.	Color Of Wire	Signal Name [Specification]
1	V	BOSE AMP_ON SIGNAL
2	LG	SOUND SIGNAL FRONT LH (+)
3	V	SOUND SIGNAL FRONT LH (-)
4	L	SOUND SIGNAL REAR LH (+)
5	R	SOUND SIGNAL REAR LH (-)
6	P	STRG SW A
7	L	ACC
10	SHIELD	SHIELD
11	L	SOUND SIGNAL FRONT RH (+)
12	P	SOUND SIGNAL FRONT RH (-)
13	R	SOUND SIGNAL REAR RH (+)
14	G	SOUND SIGNAL REAR RH (-) (Rearster model)
14	Y	SOUND SIGNAL REAR RH (-) (Coupe model)
15	B	STRG SW GND
16	L	STRG SW B
18	Y	BATTERY
20	B	GROUND

Connector No.	M88
Connector Name	AV CONTROL UNIT
Connector Type	TH32FW-NH

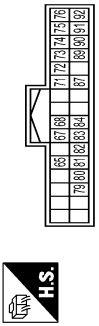

Terminal No.	Color Of Wire	Signal Name [Specification]
65	O	PARKING BRAKE SIGNAL
67	L	COMPOSITE IMAGE GND
68	G	COMPOSITE IMAGE SIGNAL
71	SHIELD	MICROPHONE GND
72	R	MICROPHONE VCC
73	G	COMM (CONTR/DSF)
74	P	CANL
75	LG	AV COMM (L)
76	LG	AV COMM (L)
79	R	IGNITION SIGNAL
80	G	ILL+
81	O	REVERSE SIGNAL
82	Y	VEHICLE SPEED SIGNAL (B-PULSE)
83	B	SHIELD
84	Y	-
87	G	MICROPHONE SIGNAL
89	R	COMM (DISP-CONT)
90	L	CANH
91	Y	AV COMM (H)
92	Y	AV COMM (H)

Connector No.	M107
Connector Name	ECM
Connector Type	RH24FY-RZP-R-LH-Z

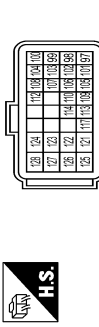

Terminal No.	Color Of Wire	Signal Name [Specification]
97	R	ACCELERATOR PEDAL POSITION SENSOR1
98	P	ACCELERATOR PEDAL POSITION SENSOR2
99	L	SENSOR POWER SUPPLY
100	W	SENSOR GROUND
101	SB	ASCD STEERING SWITCH
102	GR	EVAP CONTROL SYSTEM PRESSURE SENSOR
103	G	SENSOR POWER SUPPLY
104	GR	SENSOR GROUND
105	L	REFRIGERANT PRESSURE SENSOR
106	W	FUEL TANK TEMPERATURE SENSOR
107	BR	SENSOR POWER SUPPLY
108	Y	SENSOR GROUND
109	G	PNP SIGNAL
110	R	ENGINE SPEED OUTPUT SIGNAL
112	SB	SENSOR GROUND
113	P	CAN COMMUNICATION LINE
114	L	CAN COMMUNICATION LINE
117	Y	DATA LINK CONNECTOR
121	LG	EVAP CANISTER VENT CONTROL VALVE
122	P	STOP LAMP SWITCH
123	B	ECM GROUND
124	B	ECM GROUND
125	R	POWER SUPPLY FOR ECM
126	BR	ASCD BRAKE SWITCH
127	B	ECM GROUND
128	B	ECM GROUND

Connector No.	M118
Connector Name	BCM (BODY CONTROL MODULE)
Connector Type	M03FB-LC



Terminal No.	Color Of Wire	Signal Name [Specification]
1	W	BAT (FL)
2	W	POWER WINDOW POWER SUPPLY (BAT)
3	Y	POWER WINDOW POWER SUPPLY (IGN)

Connector No.	M119
Connector Name	BCM (BODY CONTROL MODULE)
Connector Type	NS18FW-CS

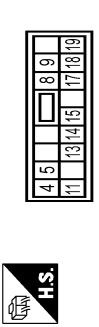

Terminal No.	Color Of Wire	Signal Name [Specification]
4	R	INTERIOR ROOM LAMP POWER SUPPLY
5	G	PASSENGER DOOR UNLOCK OUTPUT
8	V	ALL DOOR_FUEL LID UNLOCK OUTPUT
9	G	DRIVER DOOR_FUEL LID UNLOCK OUTPUT
11	BR	BAT (FUSE)
13	B	GROUND
14	R	PUSH BUTTON (IGNITION SW ILL GND)
15	Y	ACC_IND
17	W	TURN SIGNAL RH (FRONT SIDE)
18	O	TURN SIGNAL LH (FRONT SIDE)
19	P	ROOM LAMP TIMER CONTROL

HARNES LAYOUT

< DTC/CIRCUIT DIAGNOSIS >

[POWER SUPPLY&GROUND CIRCUIT]

Regular Grade

BODY No. 2 HARNES (ROADSTER MODELS) (REGULAR GRADE)

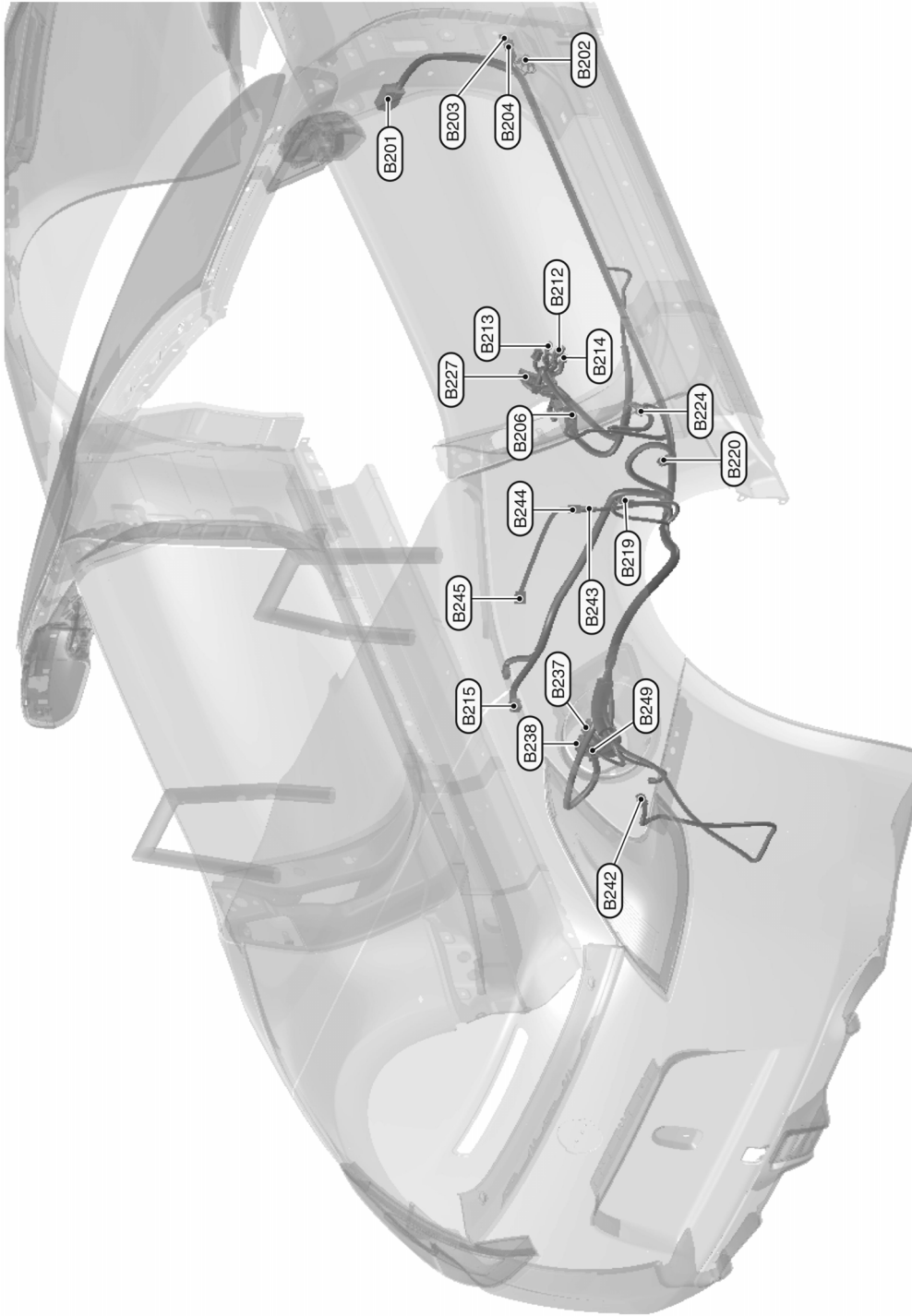

2014/05/12

JRMIC4672GB

Door Harness

DOOR HARNES (DRIVER SIDE DOOR)

INFOID:000000011375726

POWER WINDOW SERIAL LINK

< DTC/CIRCUIT DIAGNOSIS >

[COUPE]

BCM		Power window sub-switch		Continuity
Connector	Terminal	Connector	Terminal	
M123	132	D38	16	Existed

4. Check continuity between BCM connector and ground.

BCM		Ground	Continuity
Connector	Terminal		
M123	132		Not existed

Is the inspection result normal?

- YES >> Replace BCM. Refer to [BCS-106. "Removal and Installation"](#).
- NO >> Repair or replace harness.

POWER WINDOW SUB-SWITCH

< ECU DIAGNOSIS INFORMATION >

[COUPE]

POWER WINDOW SYSTEM

Connector No.	B1
Connector Name	WIRE TO WIRE
Connector Type	TH80FW-CS16-TM4

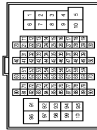

Terminal No.	Color Of Wire	Signal Name [Specification]
1	G	-
2	BG	-
3	Y	-
4	W	-
6	V	-
7	LG	-
8	GR	-
9	SB	-
11	Y	-
12	W	-
13	BR	-
14	LG	-
15	B	-
16	V	-
17	R	-
18	B	-
20	SB	-
21	G	-
22	GR	-
23	V	-
24	BG	-
25	L	-
26	P	-
27	W	-
28	SHIELD	-
31	W	-
32	B	-
33	P	-
33	W	- [Coupe models]
34	R	-
35	B	-
35	W	- [Roaster models]
36	B	- [Coupe models]
40	Y	-
41	L	-

42	GR	-
43	BR	-
44	R	-
45	BG	-
46	SB	- [Roaster models]
46	SHIELD	- [Coupe models]
47	V	-
48	SHIELD	-
51	W	-
52	R	-
57	SHIELD	-
58	B	-
60	V	-
61	SB	-
62	SHIELD	-
63	BR	-
64	Y	-
66	SHIELD	-
66	P	-
68	SHIELD	-
69	R	-
70	G	-
71	V	-
72	P	-
73	BR	-
74	GR	-
75	BG	-
80	Y	-
81	R	-
82	B	-
83	GR	-
84	G	- [Roaster models]
84	L	- [Coupe models]
85	LG	-
86	V	-
87	BR	-
88	GR	-
93	Y	-
94	G	- [Roaster models]
94	L	- [Coupe models]
95	GR	- [Coupe models]
95	LG	- [Roaster models]
96	L	-
97	Y	-
98	W	- [Coupe models]
98	Y/B	- [Roaster models]
99	LG	-
100	B	-

Connector No.	B16
Connector Name	DRIVER SIDE DOOR SWITCH
Connector Type	A03FW

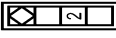

Terminal No.	Color Of Wire	Signal Name [Specification]
2	GR	-

Connector No.	B63
Connector Name	DRIVER SIDE DOOR SWITCH
Connector Type	A03FW

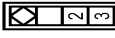

Terminal No.	Color Of Wire	Signal Name [Specification]
2	GR	-
3	B	-

Connector No.	B81
Connector Name	WIRE TO WIRE
Connector Type	TH40FW-NH



Terminal No.	Color Of Wire	Signal Name [Specification]
4	W	-
5	BR	-
6	B	-
8	Y	-
9	BG	-
14	GR	-
15	SB	-
16	V	-
17	G	-
24	LG	-
25	V	-
31	L	-
32	P	-
34	BG	-
35	R	-

Connector No.	B201
Connector Name	WIRE TO WIRE
Connector Type	TH80FW-CS16-TM4

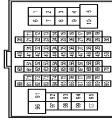

Terminal No.	Color Of Wire	Signal Name [Specification]
2	BR	- [Coupe models]
2	R	- [Roaster models]
3	B	- [Roaster models]
3	Y	- [Coupe models]

BCM (BODY CONTROL MODULE)

< ECU DIAGNOSIS INFORMATION >

[ROADSTER]

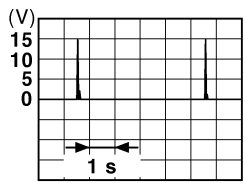
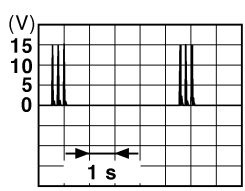
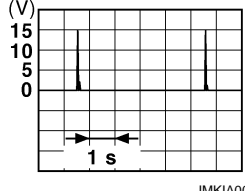
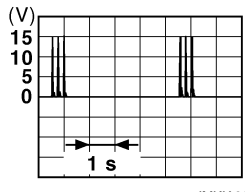
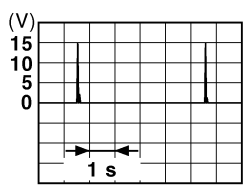
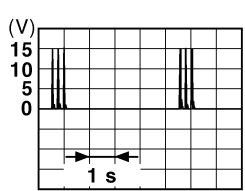
Terminal No. (Wire color)		Description		Condition	Value (Approx.)
+	-	Signal name	Input/ Output		
34 (G)	Ground	Luggage room/Trunk room antenna (-)	Output	Ignition switch OFF	When Intelligent Key is in the passenger compartment  <p style="text-align: right; font-size: small;">JMKIA0062GB</p>
				Ignition switch OFF	When Intelligent Key is not in the passenger compartment  <p style="text-align: right; font-size: small;">JMKIA0063GB</p>
35 (R)	Ground	Luggage room/Trunk room antenna (+)	Output	Ignition switch OFF	When Intelligent Key is in the passenger compartment  <p style="text-align: right; font-size: small;">JMKIA0062GB</p>
				Ignition switch OFF	When Intelligent Key is not in the passenger compartment  <p style="text-align: right; font-size: small;">JMKIA0063GB</p>
38 (B)	Ground	Rear bumper antenna (-)	Output	When the back door/trunk lid door request switch is operated with ignition switch OFF	When Intelligent Key is in the antenna detection area  <p style="text-align: right; font-size: small;">JMKIA0062GB</p>
				When the back door/trunk lid door request switch is operated with ignition switch OFF	When Intelligent Key is not in the antenna detection area  <p style="text-align: right; font-size: small;">JMKIA0063GB</p>

POWER WINDOW SUB-SWITCH

< ECU DIAGNOSIS INFORMATION >

[ROADSTER]

POWER WINDOW SUB-SWITCH

Reference Value

INFOID:000000010837859

TERMINAL LAYOUT

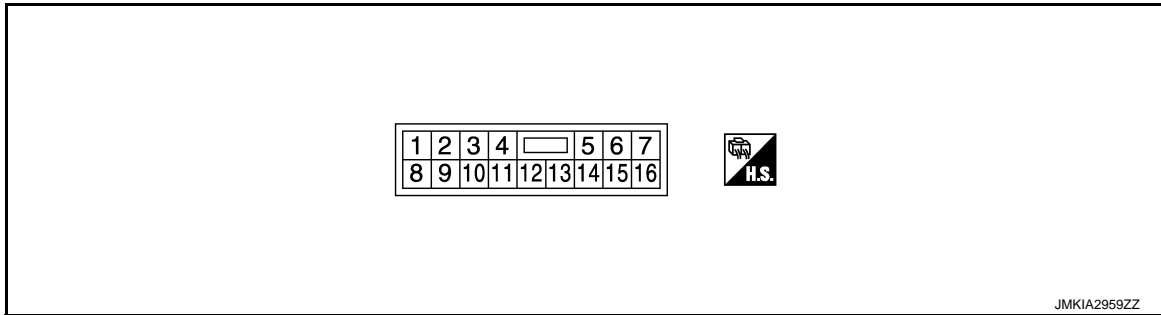

PHYSICAL VALUES

Terminal No. (Wire color)		Description		Condition	Voltage [V] (Approx.)
+	-	Signal name	Input/ Output		
3 (G)	Ground	Encoder ground	—	—	0
4 (BG)	Ground	Encoder power supply	Output	When ignition switch ON or automatic window operates adjusting	12
8 (L)	Ground	Power window motor UP signal	Output	When power window motor is operated UP	12
9 (BR)	Ground	Power window motor DOWN signal	Output	When power window motor is operated DOWN	12
10 (W)	Ground	Battery power supply	Input	—	12
11 (B)	Ground	Ground	—	—	0
12 (R)	Ground	Encoder pulse signal 1	Input	When power window motor operates	<p>JMKIA0070GB</p>
14 (Y)	Ground	Passenger side door switch	Input	OFF (Door close)	<p>JPMIA0011GB</p>
				ON (Door open)	0

COMPONENT PARTS

< SYSTEM DESCRIPTION >

- | | | |
|--|---|---|
| 13. 5th bow latch close sensor | 14. Roof drive cylinder RH (with roof status sensor RH) | 15. Storage lid drive cylinder RH (with storage lid status sensor RH) |
| 16. • Door outside handle LH (request switch)
• Door outside handle RH (request switch) | 17. 5th bow drive cylinder RH (with 5th bow status sensor RH) | 18. Roof striker sensor LH |
| 19. Roof striker sensor RH | 20. BCM
Refer to BCS-10, "Component Parts Location" | 21. Roof latch cylinder |
| 22. Roof latch lock sensor | 23. Combination meter
Refer to MWI-10, "METER SYSTEM : Component Parts Location" | 24. Roof open/close switch |
| 25. Power window main switch
Refer to PWC-120, "Component Parts Location" | 26. 5th bow drive cylinder LH (with 5th bow status sensor LH) | 27. Storage lid drive cylinder LH (with storage lid status sensor LH) |
| 28. Roof drive cylinder LH (with roof status sensor LH) | | |
| A. Behind storage room trim LH | B. Behind storage room trim LH | C. Backside of storage lid |
| D. Behind storage room trim RH | E. 2nd bow RH side | F. Behind roof front finisher |
| G. Behind front roof garnish | H. 2nd bow LH side | I. Behind storage room trim LH |

Component Description

INFOID:000000010840300

	Component	Reference page
Control unit	Soft top control unit	RF-14
	AV control unit	AV-10 (Base audio) AV-81 (Bose audio with navigation)
	BCM	BCS-9
	Combination meter	MWI-10
Input	5th bow latch close sensor	RF-12
	5th bow latch open sensor	RF-12
	5th bow status sensor (LH/RH)	RF-13
	5th bow striker sensor	RF-13
	Hydraulic pump temperature sensor	RF-13
	Roof latch lock sensor	RF-13
	Roof open/close switch	RF-13
	Roof striker sensor (LH/RH)	RF-13
	Storage lid status sensor (LH/RH)	RF-14
	Trunk room lamp switch	DLK-213
Output	Hydraulic pump relay (1/2)	RF-13
	Hydraulic pump motor	RF-13
	Switching valve (1/2/3/4/5)	RF-14
	Trunk opener actuator	DLK-213

5th Bow Latch Close Sensor

INFOID:000000010840301

5th bow close sensor is installed to storage lid inside and detects 5th bow latch state by movement of linkage. ON signal (5th bow latch close signal) is transmitted to soft top control unit when linkage lock position is detected by hydraulic control.

5th Bow Latch Open Sensor

INFOID:000000010840302

5th bow latch open sensor is installed to storage lid inside and detects 5th bow latch state by movement of linkage.

WATER LEAKAGE TROUBLE DIAGNOSIS

< BASIC INSPECTION >

- Soft top assembly position may be incorrect when glass upper position is low even if door glass adjustment is performed. Perform soft top assembly adjustment, if necessary. Refer to [RF-170, "SOFT TOP ASSEMBLY : Adjustment"](#)

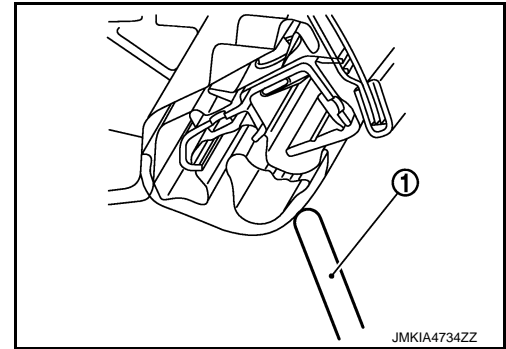

WATER LEAKAGE FROM F

Water may be entering through inside door glass rear.

Cause: There may be poor contact between rear weather-strip of soft top and door glass.

Repair Procedure 14

- Adjust door glass (1) position frontward/backward or upward/downward against soft top.

(A): 1.2 - 5.2 mm (0.05 - 0.20 in)

(B): 6.4 - 10.4 mm (0.25 - 0.41 in)

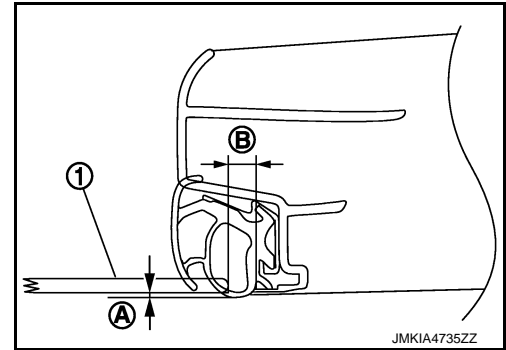

- Adjust door glass tilt contact by rotating adjusting bolt on regulator lower edge. Refer to [GW-23, "Inspection and Adjustment"](#)

CAUTION:

Soft top assembly position may be incorrect in the case of glass upper position is low even if door glass adjustment is performed. Perform soft top assembly adjustment if necessary. Refer to [RF-170, "SOFT TOP ASSEMBLY : Adjustment"](#)

Water Leakage Test

INFOID:000000010840335

Visually check for water leakage after repairing.

1. 2 workers are required. One worker checks inside the vehicle, and the other one washes with water.
2. Use 13 mm (0.51 in) diameter hose. Adjust water pressure by following method. Hold the hose horizontally, and release water at 1000 mm (39.37 in) height from ground. Adjust the distance, between the ground point just below the hose and the water dropping point, to reach 700 mm (27.56 in). (See the figure.)
3. Keeping the distance between the hose and the testing area by 100 mm (3.94 in), apply water along the area 3 times. During applying water, move the hose by 100 mm (3.94 in)/sec speed.
4. Visually check for water leakage.

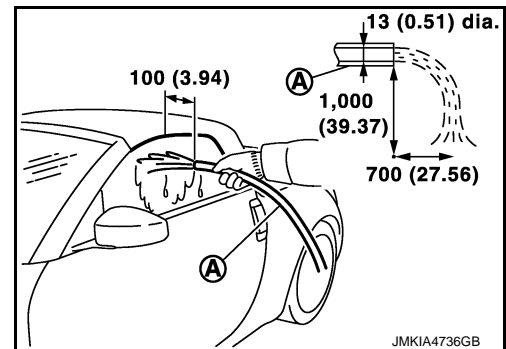

B1773 5TH BOW STATUS SENSOR (RH)

< DTC/CIRCUIT DIAGNOSIS >

B1773 5TH BOW STATUS SENSOR (RH)

DTC Logic

INFOID:000000010840412

DTC DETECTION LOGIC

NOTE:

If two or more DTCs are detected, refer to [RF-39, "DTC Inspection Priority Chart"](#), and determine trouble diagnosis order.

DTC No.	Trouble diagnosis name		DTC detecting condition	Possible cause
B1773	5BOW STATUS SEN RH	[GND-SHORT]	5th bow status sensor RH circuit is open, short to ground or short to power.	<ul style="list-style-type: none">• Harness or connectors (The sensor circuit is open or shorted.)• Soft top control unit• 5th bow status sensor RH
		[PWR-SHORT/ OPEN]		
		[OPEN]		

DTC CONFIRMATION PROCEDURE

1. PERFORM DTC CONFIRMATION PROCEDURE

1. Start engine.
2. Operate soft top to fully open and fully close.
3. Select "Self Diagnostic Result" mode of "CONVERTIBLE ROOF" using CONSULT.
4. Check DTC.

Is DTC detected?

- YES >> Go to [RF-128, "Diagnosis Procedure"](#).
NO >> INSPECTION END

Diagnosis Procedure

INFOID:000000010840413

1. CHECK 5TH BOW STATUS SENSOR RH CIRCUIT

1. Turn ignition switch OFF.
2. Disconnect 5th bow status sensor RH and soft top control unit harness connector.
3. Check the continuity between 5th bow status sensor RH harness connector and soft top control unit harness connector.

5th bow status sensor RH		Soft top control unit		Continuity
Connector	Terminal	Connector	Terminal	
B313	2	B306	68	Existed

4. Also check harness for short to ground and short to power.

Is the inspection result normal?

- YES >> GO TO 2.
NO >> Repair open circuit, short to ground or short to power in harness or connectors.

2. REPLACE HYDRAULIC UNIT

Replace hydraulic unit. Refer to [RF-238, "Removal and Installation"](#).

Is the inspection result normal?

- YES >> INSPECTION END
NO >> GO TO 3.

3. REPLACE SOFT TOP CONTROL UNIT

Replace soft top control unit. Refer to [RF-247, "Removal and Installation"](#).

Is the inspection result normal?

- YES >> INSPECTION END
NO >> GO TO 4.

4. CHECK INTERMITTENT INCIDENT

SOFT TOP

< REMOVAL AND INSTALLATION >

- | | | |
|----------------------------------|-----------------|-----------------------------------|
| 13. 3rd bow | 14. 2nd bow | 15. Soft top cover inner retainer |
| 16. Soft top mounting bracket RH | 17. Bungee cord | 18. Flipper door cable |

○ : Clip

Refer to [GI-4, "Components"](#) for symbols in the figure.

SOFT TOP COVER INNER : Removal and Installation

INFOID:000000010840463

REMOVAL

1. Operate soft top as shown in the figure.

CAUTION:

Storage lid assembly may close due to low oil pressure. Always support storage lid assembly in the fully open position using a supporting block.

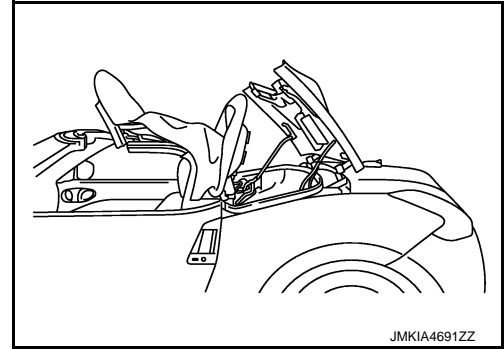

2. Remove front rail weather-strip. (LH and RH) Refer to [RF-200, "ROOF SEALING : Exploded View"](#).
3. Remove front rail weather-strip retainer. (LH and RH) Refer to [RF-200, "ROOF SEALING : Exploded View"](#).
4. Remove soft top cover outer front retainer mounting screws (A).

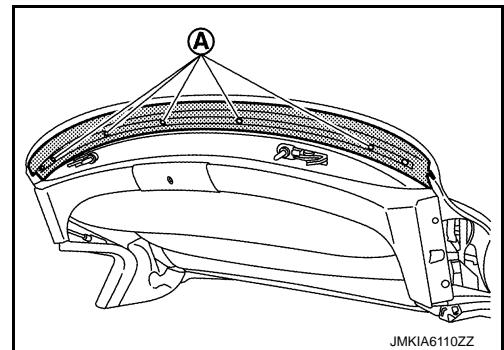

5. Lift up soft top cover outer front retainer (1), and then pull up soft top cover outer (2) portion (A) to outside (both LH and RH).

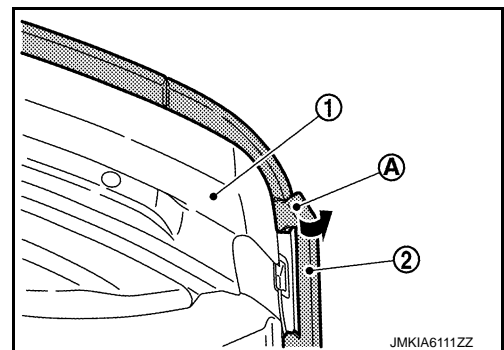

HYDRAULIC SYSTEM

< REMOVAL AND INSTALLATION >

30. Remove E-clips (A) of 5th bow drive cylinder (1). Remove cylinder mounting pins (2) (LH and RH).

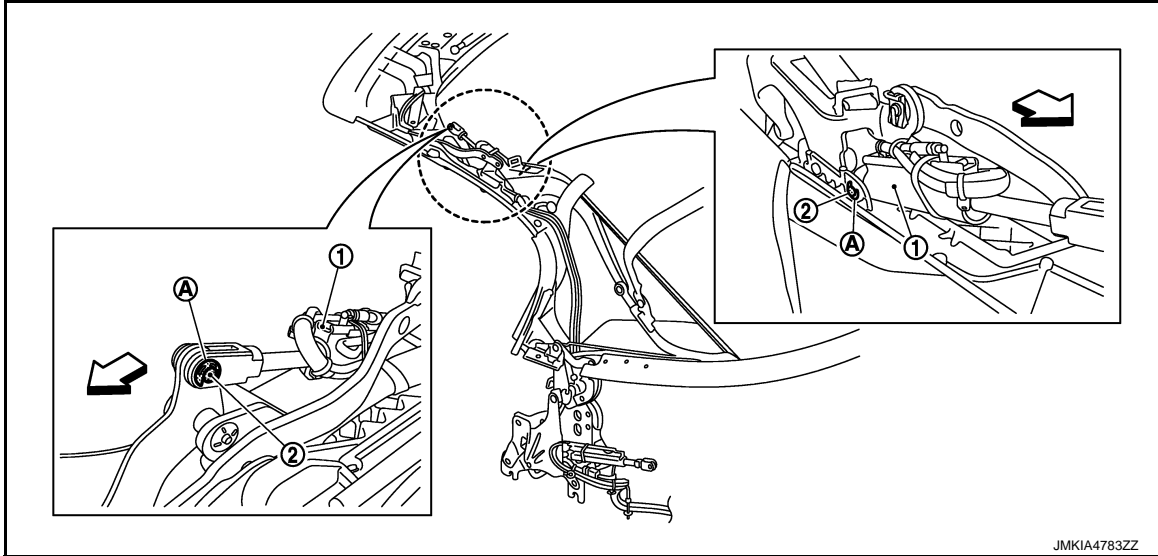

↔ : Vehicle front

31. Remove E-clip (A) and pin (1).

32. Lift up linkage (2). Pull out roof latch cylinder and oil pressure hose.

↔ : Vehicle front

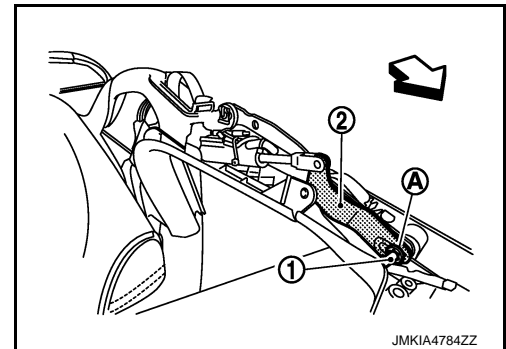

33. Place soft top assembly as shown in the figure. Maintain clearance (a).

NOTE:

Do not allow soft top assembly to apply its own weight to installation portion of the vehicle body.

CAUTION:

Be careful not to turn over soft top assembly.

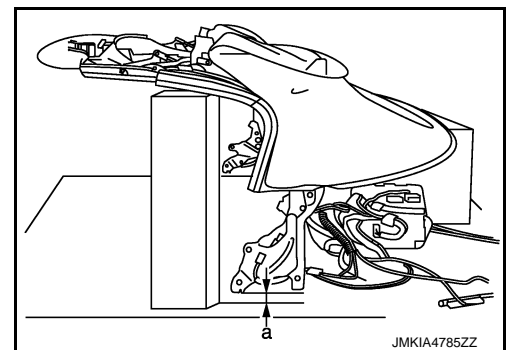

34. Remove E-clip (A). Remove mounting pin (2) of roof drive cylinder (1) (LH and RH).

↔ : Vehicle front

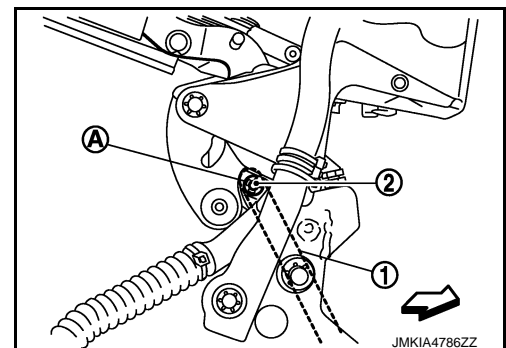

SEAT BELT WARNING LAMP DOES NOT TURN ON

< SYMPTOM DIAGNOSIS >

SEAT BELT WARNING LAMP DOES NOT TURN ON

Diagnosis Procedure

INFOID:000000010837446

1. CHECK SELF DIAGNOSIS RESULT

Perform "COMBINATION METER" self diagnostic result. Refer to [MWI-34, "CONSULT Function \(METER/M&A\)"](#)

Is DTC detected?

- YES >> Repair or replace the malfunctioning parts.
- NO >> GO TO 2.

2. CHECK POWER SUPPLY

Check that fuses are not blown.

Check ignition power supply of combination meter. Refer to [MWI-45, "COMBINATION METER : Diagnosis Procedure"](#)

Is the inspection result normal?

- YES >> GO TO 3.
- NO >> Repair or replace the malfunctioning parts.

3. CHECK SEAT BELT BUCKLE SWITCH CIRCUIT (DRIVER SIDE)

Check seat belt buckle switch circuit (driver side). Refer to [SBC-5, "DRIVER SIDE : Component Function Check"](#)

Is the inspection result normal?

- YES >> GO TO 4.
- NO >> Repair or replace the malfunctioning parts.

4. CHECK SEAT BELT BUCKLE SWITCH CIRCUIT (PASSENGER SIDE)

Check seat belt buckle switch circuit (passenger side). Refer to [SBC-7, "PASSENGER SIDE : Component Function Check"](#)

NOTE:

Except for Mexico

Is the inspection result normal?

- YES >> GO TO 5.
- NO >> Repair or replace the malfunctioning parts.

5. CHECK SEAT BELT WARNING LAMP CIRCUIT

Check seat belt warning lamp circuit. Refer to [SBC-9, "Diagnosis Procedure"](#)

Is the inspection result normal?

- YES >> GO TO 6.
- NO >> Repair or replace the malfunctioning parts.

6. CONFIRM THE OPERATION

Confirm the operation again.

Is the inspection result normal?

- YES >> Check intermittent incident. Refer to [GI-44, "Intermittent Incident"](#).
- NO >> GO TO 1.

CLIMATE CONTROLLED SEAT CONTROL UNIT

< ECU DIAGNOSIS INFORMATION >

CLIMATE CONTROLLED SEAT

Connector No.	B1
Connector Name	WIRE TO WIPE
Connector Type	TH80FW-CS16-TM4

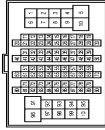

Terminal No.	Color Of Wire	Signal Name [Specification]
1	G	-
2	BG	-
3	Y	-
4	W	-
5	V	-
7	LG	-
8	GR	-
9	SB	-
11	Y	-
12	W	-
13	BR	-
14	LG	-
15	B	-
16	V	-
17	R	-
18	B	-
20	SB	-
21	G	-
22	GR	-
23	V	-
24	BG	-
25	L	-
26	P	-
27	W	-
28	SHIELD	-
31	W	-
32	B	-
33	P	- [Coupe models]
34	W	- [Roastler models]
36	R	-
38	W	- [Roastler models]
38	B	- [Coupe models]
40	Y	-
41	L	-

42	GR	-
43	BR	-
44	R	-
45	BG	-
46	SB	- [Roastler models]
46	SHIELD	- [Coupe models]
47	V	-
48	SHIELD	-
51	W	-
52	R	-
57	SHIELD	-
58	B	-
60	V	-
61	SB	-
62	SHIELD	-
63	BR	-
64	Y	-
68	SHIELD	-
68	P	-
67	L	-
68	SHIELD	-
69	R	-
70	G	-
71	V	-
72	P	-
73	BR	-
74	GR	-
75	BG	-
80	Y	-
81	R	-
82	B	-
83	GR	-
84	G	- [Coupe models]
84	L	- [Roastler models]
85	LG	-
86	V	-
87	BR	-
88	GR	-
93	Y	-
94	G	- [Roastler models]
94	L	- [Coupe models]
95	GR	- [Coupe models]
95	LG	- [Roastler models]
96	L	-
97	Y	-
98	W	- [Coupe models]
98	Y/B	- [Roastler models]
100	B	-

Connector No.	B57
Connector Name	WIRE TO WIPE
Connector Type	NS16FW-CS



Terminal No.	Color Of Wire	Signal Name [Specification]
76	L	-
76	B	-
78	LG	-
79	B	-
80	B	-
91	P	-
92	V	-
93	G	-
94	BG	-
95	GR	-
100	BR	-

Connector No.	B201
Connector Name	WIRE TO WIPE
Connector Type	TH80FW-CS16-TM4

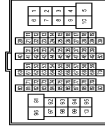

Terminal No.	Color Of Wire	Signal Name [Specification]
2	BR	- [Coupe models]
2	R	- [Roastler models]
3	Y	- [Coupe models]
3	B	- [Roastler models]
4	G	-
7	R	- [Coupe models]
7	V	- [Roastler models]
8	LG	-

9	Y	-
11	R	-
20	G	-
21	R	-
30	B	-
40	W	-
41	V	-
42	G	-
43	L	-
44	SB	-
51	P	-
52	L	-
53	SHIELD	-
54	BR	-
55	Y	-
56	SHIELD	-
57	G	- [Coupe models]
57	P	- [Roastler models]
58	L	- [Roastler models]
58	R	- [Coupe models]
59	B	-
60	W	-
61	GR	-
62	B	-
63	Y	-
64	V	-
65	SB	-
66	BG	-
67	V	-
68	P	-
69	L	-
70	G	-
71	B	- [Roastler models]
71	V	- [Coupe models]
72	L	- [Roastler models]
72	P	- [Coupe models]
73	L	- [Coupe models]
73	P	- [Roastler models]
74	P	-
75	B	-
76	B	- [Coupe models]
76	W	- [Roastler models]
77	W	-
82	LG	- [Roastler models]
82	SB	- [Coupe models]
83	V	- [Coupe models]
83	W	- [Roastler models]
84	G	-
84	Y	- [Coupe models]
94	G	- [Roastler models]
94	W	- [Coupe models]
94	Y	- [Roastler models]
94	SHIELD	- [Coupe models]

A
B
C
D
E
F
G
H
I
SE
K
L
M
N
O
P

INTELLIGENT KEY SYSTEM/ENGINE START FUNCTION

< SYSTEM DESCRIPTION >

- Operating door lock using Intelligent Key
Press push-button ignition switch and ignition switch changes to the ACC position from the OFF position.

M/T models

If any of the above conditions are met, the battery saver system is released.

POWER SUPPLY POSITION CHANGE TABLE BY PUSH-BUTTON IGNITION SWITCH OPERATION

The power supply position changing operation can be performed with the following operations.

NOTE:

- When an Intelligent Key is within the detection area of inside key antenna and when it is inserted to the key slot, it is equivalent to the operations below.
- When starting the engine, the BCM monitors under the engine start conditions,

A/T models

- Brake pedal operating condition
- Selector lever position
- Vehicle speed

M/T models

- Clutch pedal operating condition
- Vehicle speed

Vehicle speed: less than 4 km/h (2.5 MPH)

Power supply position	Engine start/stop condition			Push-button ignition switch operation frequency
	A/T models		M/T models	
	Selector lever	Brake pedal operation condition	Clutch pedal operation condition	
LOCK → ACC	—	Not depressed	Not depressed	1
LOCK → ACC → ON	—	Not depressed	Not depressed	2
LOCK → ACC → ON → OFF	—	Not depressed	Not depressed	3
LOCK → START ACC → START ON → START	P or N position	Depressed	Depressed	1
Engine is running → OFF	—	—	—	1

Vehicle speed: 4 km/h (2.5 MPH) or more

Power supply position	Engine start/stop condition			Push-button ignition switch operation frequency
	A/T models		M/T models	
	Selector lever	Brake pedal operation condition	Clutch pedal operation condition	
Engine is running → ACC	—	—	—	Emergency stop operation
Engine stall return operation while driving	N position	Not depressed	Depressed	1

Emergency stop operation

- Press and hold the push-button ignition switch for 2 seconds or more.
- Press the push-button ignition switch 3 times or more within 1.5 seconds.

B2608 STARTER RELAY

< DTC/CIRCUIT DIAGNOSIS >

B2608 STARTER RELAY

Description

INFOID:0000000010841359

Located in IPDM E/R, the starter relay runs the starter motor. The starter relay is turned ON by the BCM when the ignition switch is in the START position. IPDM E/R transmits the starter relay ON signal to BCM via CAN communication.

DTC Logic

INFOID:0000000010841360

DTC DETECTION LOGIC

NOTE:

- If DTC B2608 is displayed with DTC U1000, first perform the trouble diagnosis for DTC U1000. Refer to [SEC-31, "BCM : DTC Logic"](#).
- If DTC B2608 is displayed with DTC U1010, first perform the trouble diagnosis for DTC U1010. Refer to [SEC-33, "BCM : DTC Logic"](#).
- If DTC B2608 is displayed with DTC B210D for IPDM E/R, first perform the trouble diagnosis for DTC B210D. Refer to [SEC-83, "DTC Logic"](#).

DTC No.	Trouble diagnosis name	DTC detecting condition	Possible cause
B2608	STARTER RELAY	BCM receives starter relay ON signal (CAN) from IPDM E/R even if BCM turns the starter relay OFF.	<ul style="list-style-type: none"> • Harness or connectors (Starter relay circuit is open or shorted.) • IPDM E/R

DTC CONFIRMATION PROCEDURE

1. PERFORM DTC CONFIRMATION PROCEDURE

1. Turn ignition switch ON under the following conditions.

A/T models

- Selector lever is in the P or N position
- Do not depress brake pedal

M/T models

- Do not depress clutch pedal
2. Check "Self-diagnostic result" using CONSULT.

Is DTC detected?

- YES >> Go to [SEC-69, "Diagnosis Procedure"](#).
- NO >> INSPECTION END

Diagnosis Procedure

INFOID:0000000010841361

1. CHECK BCM POWER SUPPLY CIRCUIT

1. Turn ignition switch ON.
2. Check voltage between BCM harness connector and ground.

(+)		(-)	Condition	Voltage (V) (Approx.)	
BCM					
Connector	Terminal				
M121	52	Ground	Selector lever (A/T models)	N or P position	12
				Other than above	0
			Clutch pedal (M/T models)	Depressed	Battery voltage
				Not depressed	0

Is the measurement value within the specification?

- YES >> GO TO 3.
- NO >> GO TO 2.

A
B
C
D
E
F
G
H
I
J
L
M
N
O
P

SEC

VEHICLE SECURITY SYSTEM

< DTC/CIRCUIT DIAGNOSIS >

VEHICLE SECURITY SYSTEM

10	O	TRUNK LID OPEN SIGNAL
11	O	ROOF STATUS SIGNAL (INDICATOR)
12	SB	ROOF STATUS SIGNAL (AUDIO)
14	L	ROOF OPEN / CLOSE SWITCH (CLOSE)
15	LG	ROOF OPEN / CLOSE SWITCH (OPEN)
16	V	TRUNK ROOM LAMP SWITCH
17	BG	CAN-H
18	P	CAN-L
19	LG	LOCAL COMMUNICATION (POWER WINDOW)
20	V	LOCAL COMMUNICATION (BCM)
21	BR	SENSOR POWER SUPPLY (ROOF SET TRANSDUCER PWR)
29	DG	GROUND
35	P	ROOF OPEN / CLOSE SWITCH (GND)

Connector No.	D1
Connector Name	WIRE TO WIRE
Connector Type	TH46FW-CS15

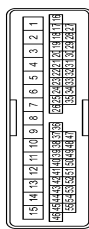

Terminal No.	Color Of Wire	Signal Name (Specification)
7	Y	-
8	Y	-
9	G	-
10	BG	-
11	P	- [With BOSE system] - [Without BOSE system]
12	L	-
13	B	-
14	SB	- [Coupe models] - [Roaster models]
15	W	-
16	Y	-
23	Y/B	-
25	R	-
26	SHIELD	-
35	G	-
44	B	-
47	B	-
48	SB	-
49	W	-
50	LG	-

51	R	-
52	V	-
53	BG	-
54	GR	-
55	G	-

Connector No.	D8
Connector Name	POWER WINDOW MAIN SWITCH
Connector Type	NS16FW-CS

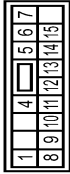

Terminal No.	Color Of Wire	Signal Name (Specification)
1	W	-
4	Y	-
5	BG	-
6	GR	-
7	V	-
8	L	-
9	LG	-
10	Y	-
11	BR	-
12	SB	- [Coupe models] - [Roaster models]
13	R	-
14	G	-
15	B	-

Connector No.	D15
Connector Name	DRIVER SIDE DOOR LOCK ASSEMBLY
Connector Type	ED36FY-RS



Terminal No.	Color Of Wire	Signal Name (Specification)
1	BG	-
2	G	-
3	SB	-
4	Y	-
5	V	-
6	GR	-

Connector No.	E5
Connector Name	IPSM ER-INTELLIGENT POWER DISTRIBUTION MODULE (ENGINE ROOM)
Connector Type	TH20FW-CS12-M4-TV



Terminal No.	Color Of Wire	Signal Name (Specification)
4	V	-
5	L	-
7	R	- [Coupe models] - [Roaster models]
12	BW	-
13	Y	-
16	LG	-
18	W	-
25	G	-
27	L	-
28	L	-
30	GR	-
36	G	-

Connector No.	E6
Connector Name	IPSM ER-INTELLIGENT POWER DISTRIBUTION MODULE (ENGINE ROOM)
Connector Type	TH18FW-NH



Terminal No.	Color Of Wire	Signal Name (Specification)
39	P	-
40	L	-
41	BW	-
42	-	-
43	SB	-
44	W	-
45	G	-
46	V	-

Connector No.	E9
Connector Name	IPSM ER-INTELLIGENT POWER DISTRIBUTION MODULE (ENGINE ROOM)
Connector Type	TH18FW-NH

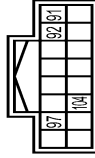

Terminal No.	Color Of Wire	Signal Name (Specification)
91	P	-
92	BG	-
97	V	-
104	LG	-

A
B
C
D
E
F
G
H
I
J
L
M
N
O
P

SEC

JRKWD6455GB

IPDM E/R (INTELLIGENT POWER DISTRIBUTION MODULE ENGINE ROOM)

< ECU DIAGNOSIS INFORMATION >

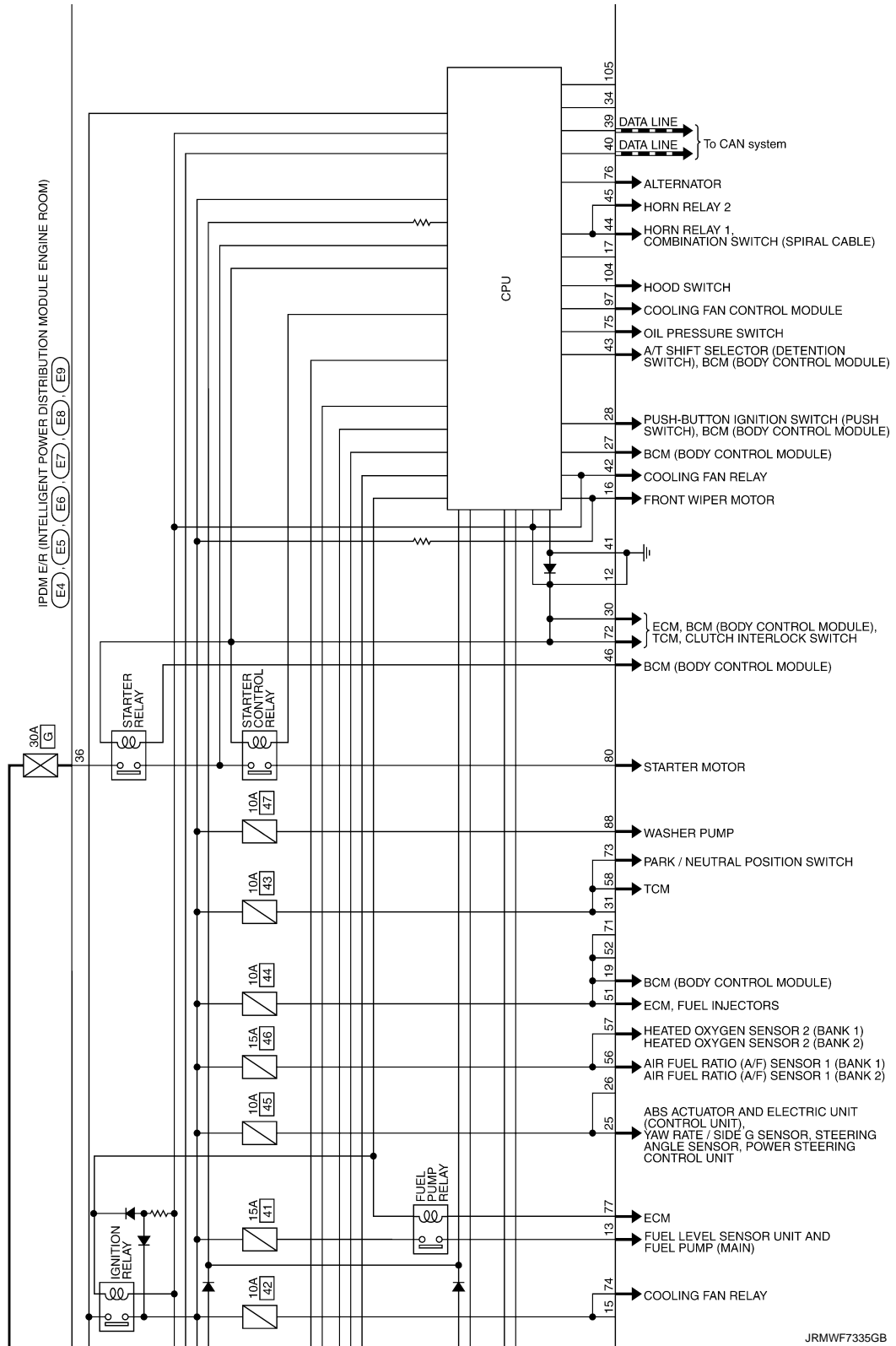

A
B
C
D
E
F
G
H
I
J
K
L
M
N
O
P

SEC

B1088 SEAT BELT PRE-TENSIONER LH	343	DTC Logic	365
Description	343	Diagnosis Procedure	365
DTC Logic	343		
Diagnosis Procedure	343		
B1089 SEAT BELT PRE-TENSIONER LH	345	B1130 SIDE AIR BAG MODULE RH	367
Description	345	Description	367
DTC Logic	345	DTC Logic	367
Diagnosis Procedure	345	Diagnosis Procedure	367
B1090, B1091, B1092, B1093, B1094, B1095		B1131 SIDE AIR BAG MODULE RH	369
DIAGNOSIS SENSOR UNIT	347	Description	369
Description	347	DTC Logic	369
DTC Logic	347	Diagnosis Procedure	369
Diagnosis Procedure	347		
B1106, B1107, B1108, B1109, B1110, B1111		B1132 SIDE AIR BAG MODULE RH	371
DIAGNOSIS SENSOR UNIT	349	Description	371
Description	349	DTC Logic	371
DTC Logic	349	Diagnosis Procedure	371
Diagnosis Procedure	349		
B1113, B1114 SATELLITE SENSOR RH	351	B1134 SIDE AIR BAG MODULE LH	373
Description	351	Description	373
DTC Logic	351	DTC Logic	373
Diagnosis Procedure	351	Diagnosis Procedure	373
B1115 SATELLITE SENSOR RH	353	B1135 SIDE AIR BAG MODULE LH	375
Description	353	Description	375
DTC Logic	353	DTC Logic	375
Diagnosis Procedure	353	Diagnosis Procedure	375
B1116 SATELLITE SENSOR RH	355	B1136 SIDE AIR BAG MODULE LH	377
Description	355	Description	377
DTC Logic	355	DTC Logic	377
Diagnosis Procedure	355	Diagnosis Procedure	377
B1118, B1119 SATELLITE SENSOR LH	357	B1137 SIDE AIR BAG MODULE LH	379
Description	357	Description	379
DTC Logic	357	DTC Logic	379
Diagnosis Procedure	357	Diagnosis Procedure	379
B1120 SATELLITE SENSOR LH	359	B1138, B1139, B1140, B1141, B1142, B1143	
Description	359	DIAGNOSIS SENSOR UNIT	381
DTC Logic	359	Description	381
Diagnosis Procedure	359	DTC Logic	381
B1121 SATELLITE SENSOR LH	361	Diagnosis Procedure	381
Description	361	B1144 DIAGNOSIS SENSOR UNIT	383
DTC Logic	361	Description	383
Diagnosis Procedure	361	DTC Logic	383
B1122, B1123, B1124, B1125, B1126, B1127		Diagnosis Procedure	383
DIAGNOSIS SENSOR UNIT	363	B1154, B1155, B1156, B1157, B1158, B1159	
Description	363	DIAGNOSIS SENSOR UNIT	384
DTC Logic	363	Description	384
Diagnosis Procedure	363	DTC Logic	384
B1129 SIDE AIR BAG MODULE RH	365	Diagnosis Procedure	384
Description	365	B1170, B1171, B1172, B1173, B1174, B1175	
		DIAGNOSIS SENSOR UNIT	386
		Description	386
		DTC Logic	386
		Diagnosis Procedure	386

B1411, B1412, B1413, B1414, B1415 AIR BAG DIAGNOSIS SENSOR UNIT

< DTC/CIRCUIT DIAGNOSIS >

[COUPE (EXCEPT FOR MEXICO)]

B1411, B1412, B1413, B1414, B1415 AIR BAG DIAGNOSIS SENSOR UNIT

DTC Logic

INFOID:000000011319584

DTC DETECTION LOGIC

DTC	CONSULT screen items (Trouble diagnosis content)		DTC detecting condition	Possible cause
B1411-00	CONTROL UNIT (airbag control unit internal trouble, SUB IC)	[UNIT MALFUNC]	Air bag diagnosis sensor unit is malfunctioning	Malfunction in air bag diagnosis sen- sor unit
B1412-00	CONTROL UNIT (airbag control unit internal trouble, communication IC1)	[UNIT MALFUNC]		
B1413-00	CONTROL UNIT (airbag control unit internal trouble, communication IC2)	[UNIT MALFUNC]		
B1414-00	CONTROL UNIT [airbag control unit internal trouble, Main micro controller (CPU)]	[UNIT MALFUNC]		
B1415-00	CONTROL UNIT [airbag control unit internal trouble, Sub microcontroller (CPU)]	[UNIT MALFUNC]		

DTC CONFIRMATION PROCEDURE

1. CHECK SELF-DIAG RESULT

Ⓟ With CONSULT

1. Turn ignition switch ON.
2. Perform "Self Diagnostic Result" mode of "AIR BAG" using CONSULT.

Ⓟ Without CONSULT

1. Turn ignition switch ON.
2. Check the air bag warning lamp status. Refer to [SRC-20, "Diagnosis with Air Bag Warning Lamp"](#).

NOTE:

SRS does not enter the diagnosis mode if no malfunction is detected in the user mode.

Is malfunctioning part detected?

- YES >> Refer to [SRC-66, "Diagnosis Procedure"](#).
NO >> INSPECTION END

Diagnosis Procedure

INFOID:000000011319585

WARNING:

- Before servicing, turn ignition switch OFF, disconnect battery negative terminal, and wait at least 3 minutes or more. (To discharge backup capacitor.)
- Never use unspecified tester or other measuring device.

1. CHECK HARNESS CONNECTOR

Check the harness connector.

Is the inspection result normal?

- YES >> GO TO 2.
NO >> Replace harness connectors.

2. CHECK WIRING HARNESS

Check the wiring harness externals.

Is the inspection result normal?

- YES >> GO TO 3.

B1037, B1038, B1039, B1040, B1041 CRASH ZONE SENSOR

< DTC/CIRCUIT DIAGNOSIS >

[COUPE (FOR MEXICO)]

B1037, B1038, B1039, B1040, B1041 CRASH ZONE SENSOR

Description

INFOID:000000010841686

Crash zone sensor is a G sensor that outputs voltage signal during deceleration at the time of a vehicle frontal collision that is more than the specified limit is detected.

DTC Logic

INFOID:000000010841687

DTC DETECTION LOGIC

DTC	CONSULT screen terms	DTC detecting condition	Possible cause
B1037 B1039 B1041	CRASH ZONE SENS1	Crash zone sensor is malfunctioning	<ul style="list-style-type: none">• Disconnection of wiring harness• Malfunction in crash zone sensor• Malfunction in air bag diagnosis sensor unit
B1038	CRASH ZONE SEN [OPEN/UPR-VB-SHORT]		
B1040	CRASH ZONE SEN [SHORT/UPR-GND-SHORT]		

DTC CONFIRMATION PROCEDURE

1. CHECK SELF-DIAG RESULT

With CONSULT

1. Turn ignition switch ON.
2. Perform "AIR BAG" Self Diagnostic Result.

Without CONSULT

1. Turn ignition switch ON.
2. Check the air bag warning lamp status. Refer to [SRC-107, "Diagnosis with Air Bag Warning Lamp"](#).

NOTE:

SRS does not enter the diagnosis mode if no malfunction is detected in the user mode.

Is malfunctioning part detected?

- YES >> Refer to [SRC-124, "Diagnosis Procedure"](#).
NO >> INSPECTION END

Diagnosis Procedure

INFOID:000000010841688

WARNING:

- Before servicing, turn ignition switch OFF, disconnect battery negative terminal, and wait 3 minutes or more. (To discharge backup capacitor.)
- Never use unspecified tester or other measuring device.

1. CHECK HARNESS CONNECTOR

Check the harness connector.

Is the inspection result normal?

- YES >> GO TO 2.
NO >> Replace harness connectors.

2. CHECK WIRING HARNESS

Check the wiring harness externals.

Is the inspection result normal?

- YES >> GO TO 3.
NO >> Replace wiring harness.

3. REPLACE CRASH ZONE SENSOR

1. Replace crash zone sensor. Refer to [SR-23, "Removal and Installation"](#).
2. Perform DTC confirmation procedure. Refer to [SRC-124, "DTC Logic"](#).

Is DTC detected?

B1130 SIDE AIR BAG MODULE RH

< DTC/CIRCUIT DIAGNOSIS >

[COUPE (FOR MEXICO)]

B1130 SIDE AIR BAG MODULE RH

Description

INFOID:000000010841773

In case of side collision where acceleration is more than the specified level, the ignition materials are ignited by electric ignition system. The system burns the gas generating materials resulting in a chemical reaction. This generates hot gases that flow into the air bag through a filter and expand the bag.

DTC Logic

INFOID:000000010841774

DTC DETECTION LOGIC

DTC	Display contents of CONSULT	DTC detecting condition	Possible cause
B1130	SIDE MODULE RH [VB-SHORT]	Side air bag module RH circuit is shorted to power supply circuit	<ul style="list-style-type: none">• Disconnection of wiring harness and short• Malfunction in side air bag module RH• Malfunction in air bag diagnosis sensor unit

DTC CONFIRMATION PROCEDURE

1. CHECK SELF-DIAG RESULT

With CONSULT

1. Turn ignition switch ON.
2. Perform "AIR BAG" Self Diagnostic Result.

Without CONSULT

1. Turn ignition switch ON.
2. Check the air bag warning lamp status. Refer to [SRC-107, "Diagnosis with Air Bag Warning Lamp"](#).

NOTE:

SRS does not enter the diagnosis mode if no malfunction is detected in the user mode.

Is malfunctioning part detected?

- YES >> Refer to [SRC-182, "Diagnosis Procedure"](#).
NO >> INSPECTION END

Diagnosis Procedure

INFOID:000000010841775

WARNING:

- Before servicing, turn ignition switch OFF, disconnect battery negative terminal, and wait at least 3 minutes or more. (To discharge backup capacitor.)
- Never use unspecified tester or other measuring device.

1. CHECK HARNESS CONNECTOR

Check the harness connector.

Is the inspection result normal?

- YES >> GO TO 2.
NO >> Replace harness connector.

2. CHECK WIRING HARNESS

Check the wiring harness externals.

Is the inspection result normal?

- YES >> GO TO 3.
NO >> Replace wiring harness.

3. REPLACE AIR BAG DIAGNOSIS SENSOR UNIT

1. Replace air bag diagnosis sensor unit. Refer to [SR-27, "COUPE : Exploded View"](#).
2. Perform DTC confirmation procedure. Refer to [SRC-182, "DTC Logic"](#).

Is DTC detected?

- YES >> GO TO 4.
NO >> INSPECTION END

B1339 SATELLITE SENSOR RH

< DTC/CIRCUIT DIAGNOSIS >

[COUPE (FOR MEXICO)]

B1339 SATELLITE SENSOR RH

Description

INFOID:000000010841868

Front door satellite sensor outputs voltage signal of pressure inside the front door.

DTC Logic

INFOID:000000010841869

DTC DETECTION LOGIC

DTC	Display contents of CONSULT	DTC detecting condition	Possible cause
B1339	FR-RH DOOR SATEL SENS [MIS-INSTALLATION]	Front door satellite sensor RH is out of the specified specification	Diagnosis sensor unit or front door satellite sensor RH is different from the part specified

DTC CONFIRMATION PROCEDURE

1. CHECK SELF-DIAG RESULT

With CONSULT

1. Turn ignition switch ON.
2. Perform "Self Diagnostic Result" mode of "AIR BAG" using CONSULT.

Without CONSULT

1. Turn ignition switch ON.
2. Check the air bag warning lamp status. Refer to [SRC-107, "Diagnosis with Air Bag Warning Lamp"](#).

NOTE:

SRS does not enter the diagnosis mode if no malfunction is detected in the user mode.

Is malfunctioning part detected?

- YES >> Refer to [SRC-240, "Diagnosis Procedure"](#).
NO >> INSPECTION END

Diagnosis Procedure

INFOID:000000010841870

WARNING:

- Before servicing, turn ignition switch OFF, disconnect battery negative terminal, and wait at least 3 minutes or more. (To discharge backup capacitor.)
- Never use unspecified tester or other measuring device.

1. REPLACE FRONT DOOR SATELLITE SENSOR

1. Replace front door satellite sensor RH. Refer to [SR-25, "Removal and Installation"](#).
2. Perform DTC confirmation procedure. Refer to [SRC-240, "DTC Logic"](#).

Is DTC detected?

- YES >> GO TO 2.
NO >> INSPECTION END

2. REPLACE AIR BAG DIAGNOSIS SENSOR UNIT

1. Replace air bag diagnosis sensor unit. Refer to [SR-27, "COUPE : Removal and Installation"](#).
2. Perform DTC confirmation procedure. Refer to [SRC-240, "DTC Logic"](#).

Is DTC detected?

- YES >> GO TO 1.
NO >> INSPECTION END

B1026, B1027, B1028, B1029, B1030, B1031 DIAGNOSIS SENSOR UNIT

< DTC/CIRCUIT DIAGNOSIS >

[ROADSTER]

Is DTC detected?

YES >> GO TO 1.

NO >> INSPECTION END

B1116 SATELLITE SENSOR RH

[ROADSTER]

< DTC/CIRCUIT DIAGNOSIS >

1. Replace satellite sensor RH. Refer to [SR-25, "Exploded View"](#).
2. Perform DTC confirmation procedure. Refer to [SRC-355, "DTC Logic"](#).

Is DTC detected?

- YES >> GO TO 1.
NO >> INSPECTION END

B1263 DOOR-MOUNTED CURTAIN AIR BAG MODULE LH

< DTC/CIRCUIT DIAGNOSIS >

[ROADSTER]

4. REPLACE DOOR-MOUNTED CURTAIN AIR BAG MODULE

1. Replace door-mounted curtain air bag module LH. Refer to [SR-21, "Exploded View"](#)
2. Perform DTC confirmation procedure. Refer to [SRC-413, "DTC Logic"](#).

Is DTC detected?

YES >> GO TO 1.

NO >> INSPECTION END

STEERING GEAR AND LINKAGE

< REMOVAL AND INSTALLATION >

[REGULAR GRADE]

- | | | |
|---------------------------------|--------------------|---------------------------|
| 10. Boot clamp (stainless wire) | 11. Spacer | 12. Inner socket |
| 13. Boot | 14. Boot clamp | 15. Outer socket lock nut |
| 16. Outer socket | 17. Cylinder tubes | |

: Apply power steering fluid.

: Apply Genuine High Performance Thread Sealant or equivalent. Refer to [GI-22, "Recommended Chemical Products and Sealants"](#).

: Apply Genuine Medium Strength Thread Locking Sealant or equivalent. Refer to [GI-22, "Recommended Chemical Products and Sealants"](#).

: Apply multi-purpose grease.

Refer to [GI-4, "Components"](#) for symbols not described on the above.

Removal and Installation

INFOID:000000010837369

REMOVAL

1. Set the vehicle to the straight-ahead position.
2. Remove tires with a power tool.
3. Remove front suspension member stay. Refer to [FSU-21, "Exploded View"](#).
4. Remove cotter pin (1), and then loosen the nut.

5. Remove steering outer socket (2) from steering knuckle (3) so as not to damage ball joint boot (4) using suitable ball joint remover (commercial service tool).

CAUTION:

Temporarily tighten the nut to prevent damage to threads and to prevent the ball joint remover from sudden drop.

6. Remove high pressure piping and low pressure piping of hydraulic piping, and then drain power steering fluid.
7. Remove power steering solenoid valve harness connector.
8. Remove rack stay. Refer to [ST-20, "Exploded View"](#).
9. Remove lower joint fixing bolt (steering gear side).

10. Separate the lower joint from the steering gear assembly by sliding the slide shaft (A: sliding range).

CAUTION:

- **Spiral cable may be cut if steering wheel turns while separating steering column assembly and steering gear assembly. Be sure to secure steering wheel using string to avoid turning.**
- **When removing lower joint, never insert a tool, such as a screwdriver, into the yoke groove to pull out the lower joint. In case of the violation of the above, replace lower joint with a new one.**

11. Remove the mounting bolts and nuts of steering gear assembly.
12. Remove steering gear assembly.

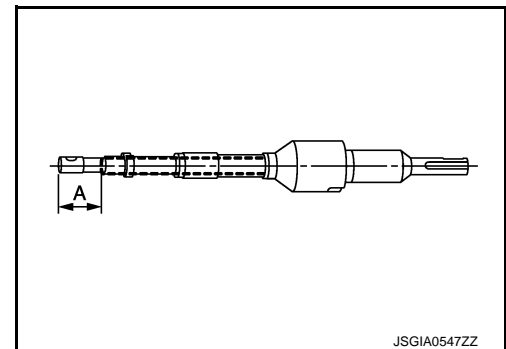
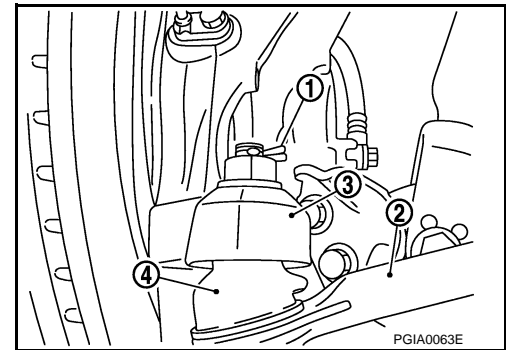

INSTALLATION

Note the following, and install in the reverse order of removal.

CAUTION:

Spiral cable may be cut if steering wheel turns while separating steering column assembly and steering gear assembly. Always fix the steering wheel using string to avoid turning.

PRECAUTIONS

< PRECAUTION >

PRECAUTION

PRECAUTIONS EXCEPT FOR MEXICO

EXCEPT FOR MEXICO : Precautions for Supplemental Restraint System (SRS) "AIR BAG" and "SEAT BELT PRE-TENSIONER"

INFOID:000000010837906

The Supplemental Restraint System such as "AIR BAG" and "SEAT BELT PRE-TENSIONER", used along with a front seat belt, helps to reduce the risk or severity of injury to the driver and front passenger for certain types of collision. This system includes seat belt switch inputs and dual stage front air bag modules. The SRS system uses the seat belt switches to determine the front air bag deployment, and may only deploy one front air bag, depending on the severity of a collision and whether the front occupants are belted or unbelted. Information necessary to service the system safely is included in the "SRS AIR BAG" and "SEAT BELT" of this Service Manual.

WARNING:

Always observe the following items for preventing accidental activation.

- To avoid rendering the SRS inoperative, which could increase the risk of personal injury or death in the event of a collision that would result in air bag inflation, all maintenance must be performed by an authorized NISSAN/INFINITI dealer.
- Improper maintenance, including incorrect removal and installation of the SRS, can lead to personal injury caused by unintentional activation of the system. For removal of Spiral Cable and Air Bag Module, see "SRS AIR BAG".
- Never use electrical test equipment on any circuit related to the SRS unless instructed to in this Service Manual. SRS wiring harnesses can be identified by yellow and/or orange harnesses or harness connectors.

PRECAUTIONS WHEN USING POWER TOOLS (AIR OR ELECTRIC) AND HAMMERS

WARNING:

Always observe the following items for preventing accidental activation.

- When working near the Air Bag Diagnosis Sensor Unit or other Air Bag System sensors with the ignition ON or engine running, never use air or electric power tools or strike near the sensor(s) with a hammer. Heavy vibration could activate the sensor(s) and deploy the air bag(s), possibly causing serious injury.
- When using air or electric power tools or hammers, always switch the ignition OFF, disconnect the battery, and wait at least 3 minutes before performing any service.

EXCEPT FOR MEXICO : Precaution for Battery Service

INFOID:000000010837907

Before disconnecting the battery, lower both the driver and passenger windows. This will prevent any interference between the window edge and the vehicle when the door is opened/closed. During normal operation, the window slightly raises and lowers automatically to prevent any window to vehicle interference. The automatic window function will not work with the battery disconnected.

EXCEPT FOR MEXICO : Precaution for Procedure without Cowl Top Cover

INFOID:000000011326997

When performing the procedure after removing cowl top cover, cover the lower end of windshield with urethane, etc to prevent damage to windshield.

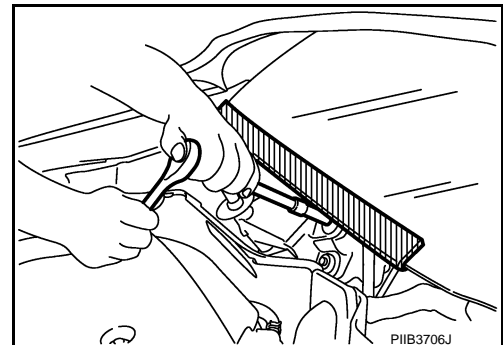

TRANSMISSION ASSEMBLY

< UNIT DISASSEMBLY AND ASSEMBLY >

[6MT: FS6R31A]

UNIT DISASSEMBLY AND ASSEMBLY

TRANSMISSION ASSEMBLY

WITHOUT S-MODE

WITHOUT S-MODE : Exploded View

INFOID:000000010839047

CASE AND EXTENSION

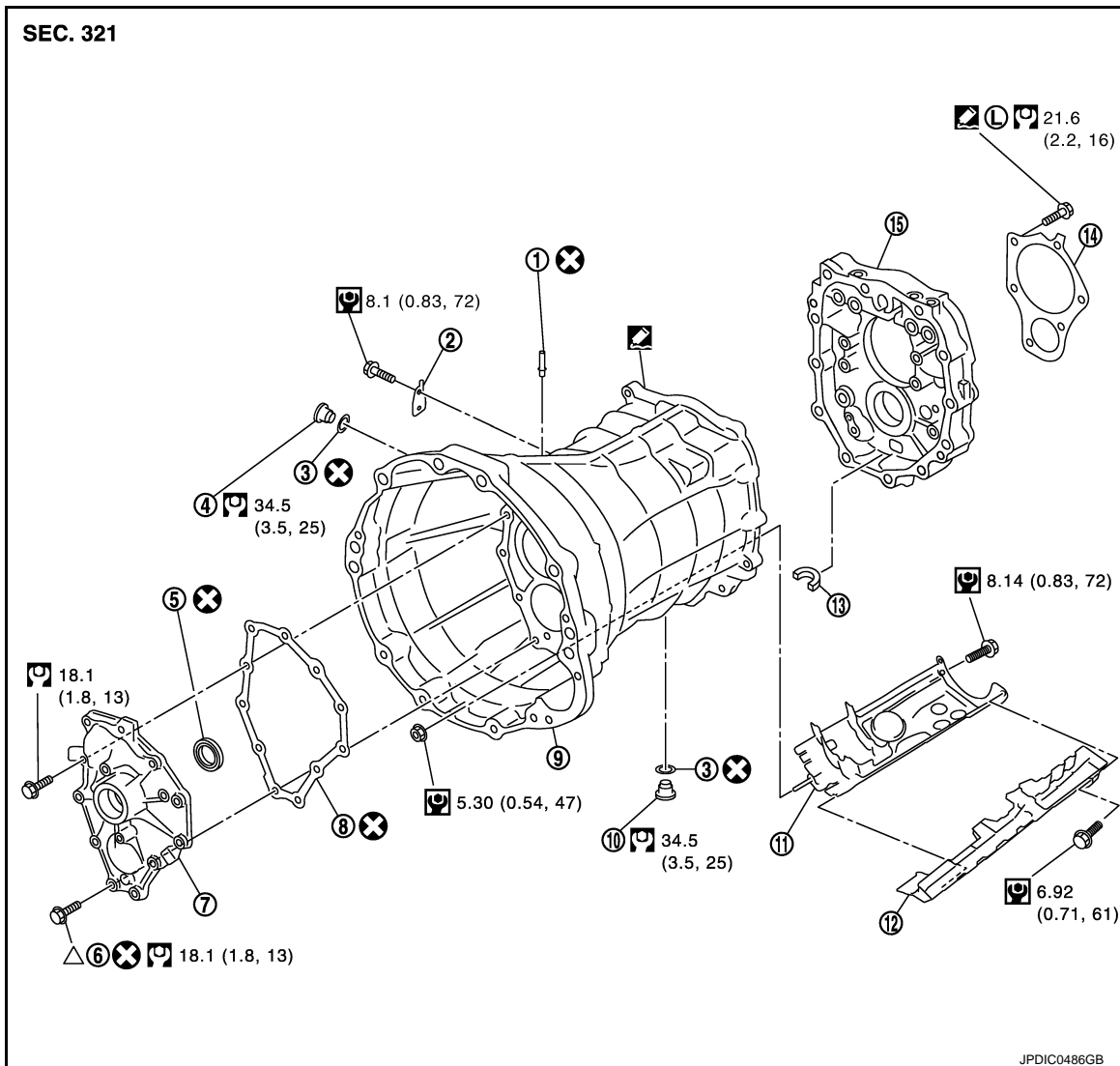

- | | | |
|------------------|-----------------------|----------------------|
| 1. Breather tube | 2. Bracket | 3. Gasket |
| 4. Filler plug | 5. Front oil seal | 6. Sealing bolt |
| 7. Front cover | 8. Front cover gasket | 9. Transmission case |
| 10. Drain plug | 11. Baffle plate | 12. Oil gutter |
| 13. Magnet | 14. Bearing retainer | 15. Adapter plate |

: Apply Genuine Silicone RTV or an equivalent. Refer to [GI-22, "Recommended Chemical Products and Sealants"](#).

: Apply Genuine Medium Strength Thread Locking Sealant or an equivalent. Refer to [GI-22, "Recommended Chemical Products and Sealants"](#).

: Refer to "CASE AND EXTENSION" in [TM-63, "WITHOUT S-MODE : Assembly"](#) for the locations.

Refer to [GI-4, "Components"](#) for symbols not described on the above.

TRANSMISSION ASSEMBLY

< UNIT DISASSEMBLY AND ASSEMBLY >

[6MT: FS6R31A]

3. Install baffle plate with the following procedure.
 - a. Tighten mounting nut (←) to the specified torque.

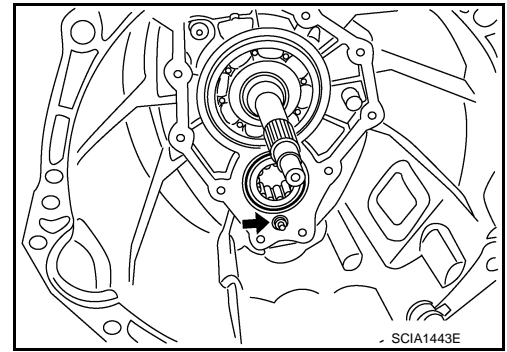

A

B

C

TM

- b. Install mounting bolt (←) to adapter plate and then tighten mounting bolt to the specified torque.

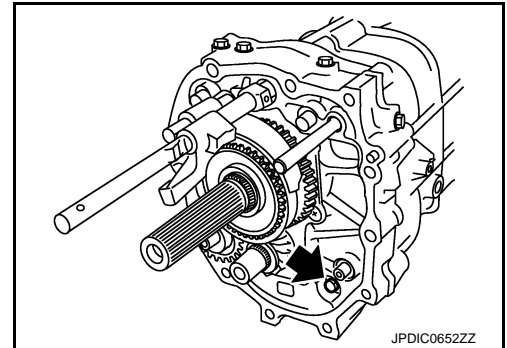

E

F

G

H

4. Install front cover with the following procedure.
 - a. Install front oil seal (1) to front cover, using the drift (A) [SST: KV38102100 (J-25803-01)].

Dimension "H" : 8.55 – 9.55 mm (0.3366 – 0.3760 in)

CAUTION:

Never incline front oil seal.

- b. Install front cover gasket and front cover to transmission case.

CAUTION:

- Never reuse front cover gasket.
- Never damage front oil seal.
- Remove any moisture, oil, or foreign material adhering to both mating surfaces.

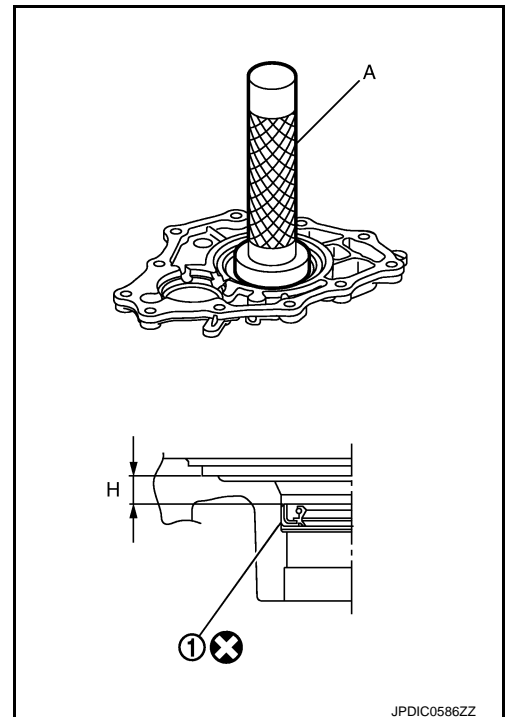

I

J

K

L

M

N

O

P

SHIFT PATTERN CONTROL

< SYSTEM DESCRIPTION >

[7AT: RE7R01A]

SHIFT PATTERN : Component Parts Location

INFOID:0000000110839097

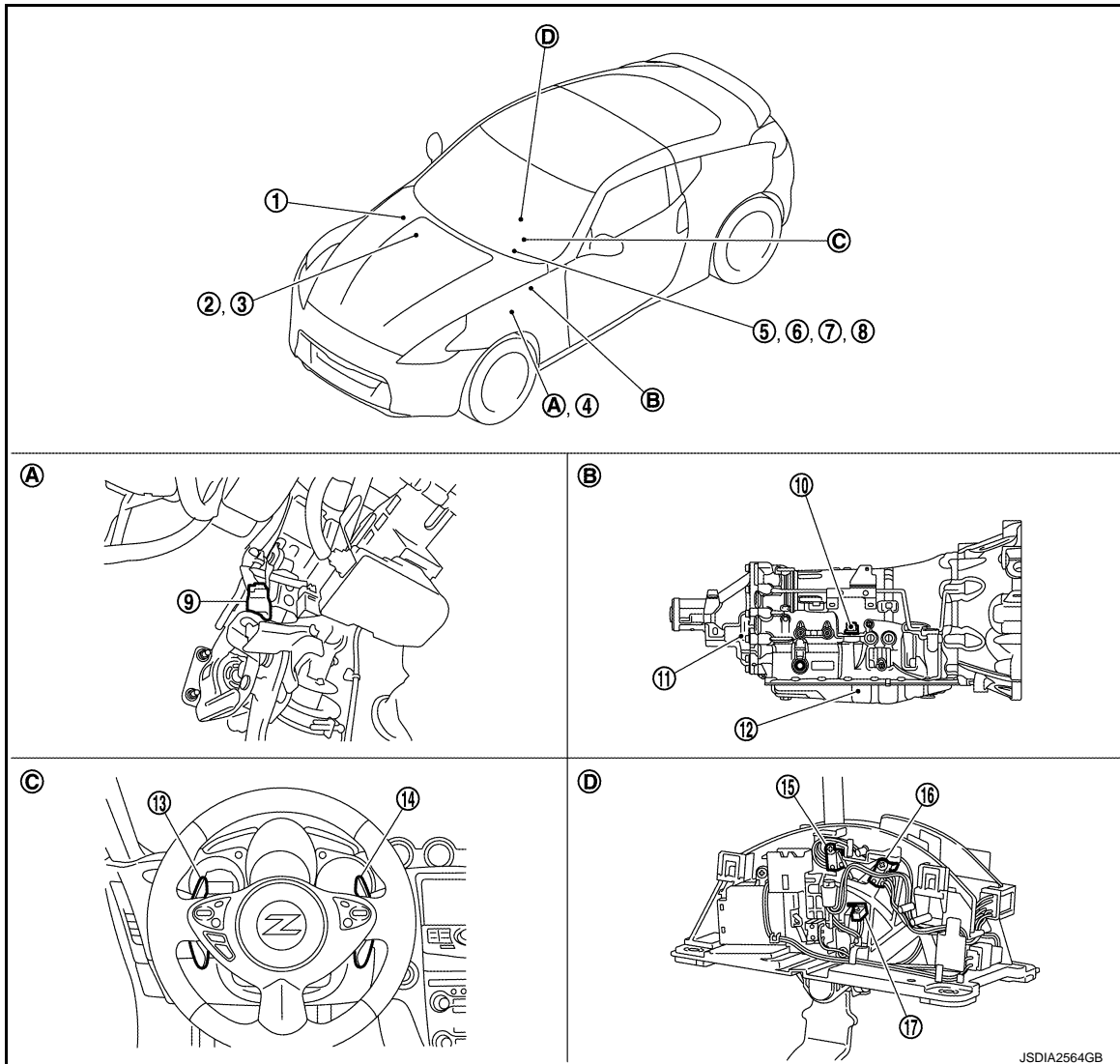

- | | | |
|--|--|---|
| 1. IPDM E/R
Refer to PCS-5, "Component Parts Location" . | 2. ECM
Refer to EC-40, "Component Parts Location" . | 3. BCM
Refer to BCS-10, "Component Parts Location" . |
| 4. Accelerator pedal position sensor
Refer to EC-40, "Component Parts Location" . | 5. Combination meter | 6. A/T CHECK indicator lamp
(On the combination meter) |
| 7. Shift position indicator
(On the combination meter) | 8. Manual mode indicator
(On the combination meter) | 9. Stop lamp switch |
| 10. Joint connector | 11. Output speed sensor | 12. Control valve & TCM* |
| 13. Paddle shifter (shift-down) | 14. Paddle shifter (shift-up) | 15. Manual mode position select switch
(shift-up) |
| 16. Manual mode position select switch
(shift-down) | 17. Manual mode select switch | |
| A. Brake pedal | B. A/T assembly | C. Steering wheel |
| D. A/T shift selector assembly | | |

*: Control valve & TCM is included in A/T assembly.

NOTE:

The following components are included in control valve & TCM.

- TCM
- Input speed sensor 1, 2

A
B
C
TM
E
F
G
H
I
J
K
L
M
N
O
P

P0720 OUTPUT SPEED SENSOR

< DTC/CIRCUIT DIAGNOSIS >

[7AT: RE7R01A]

P0720 OUTPUT SPEED SENSOR

Description

INFOID:000000010839138

The output speed sensor detects the revolution of the parking gear and emits a pulse signal. The pulse signal is transmitted to the TCM which converts it into vehicle speed.

DTC Logic

INFOID:000000010839139

DTC DETECTION LOGIC

DTC	Trouble diagnosis name	DTC is detected if...	Possible cause
P0720	Output Speed Sensor Circuit	<ul style="list-style-type: none"> The vehicle speed detected by the output speed sensor is 5 km/h (3 MPH) or less when the vehicle speed transmitted from the combination meter to TCM is 20 km/h (13 MPH) or more. (Only when starts after the ignition switch is turned ON.) The vehicle speed transmitted from the combination meter to TCM does not decrease despite the 36 km/h (23 MPH) or more of deceleration in vehicle speed detected by the output speed sensor. when the vehicle speed detected by the output speed sensor is 36 km/h (23 MPH) or more and the vehicle speed transmitted from the combination meter to TCM is 24 km/h (15 MPH) or more. 	<ul style="list-style-type: none"> Harness or connectors (Sensor circuit is open.) Output speed sensor

DTC CONFIRMATION PROCEDURE

CAUTION:

- Always drive vehicle at a safe speed.
- Be careful not to rev engine into the red zone on the tachometer.

1. PRECONDITIONING

If "DTC CONFIRMATION PROCEDURE" is previously conducted, always turn ignition switch OFF and wait at least 10 seconds before performing the next test.

>> GO TO 2.

2. CHECK DTC DETECTION

With CONSULT

- Start the engine.
- Select "ESTM VSP SIG" in "Data Monitor" in "TRANSMISSION".
- Drive vehicle and maintain the following conditions for 60 seconds or more.

ESTM VSP SIG : 40 km/h (25 MPH) or more

- Perform "Self Diagnostic Results" in "TRANSMISSION".

With GST

Follow the procedure "With CONSULT".

Is "P0720" detected?

- YES >> Go to [TM-224. "Diagnosis Procedure"](#).
 NO >> INSPECTION END

TCM

< ECU DIAGNOSIS INFORMATION >

[7AT: RE7R01A]

Item name	Condition	Value (Approx.) / Status	
I/C SOLENOID	—	—	A
D/C SOLENOID	—	—	
2346/B SOL	—	—	B
L/P SOL MON	—	—	
TCC SOL MON	—	—	
L/B SOL MON	—	—	C
FR/B SOL MON	—	—	
HLR/C SOL MON	—	—	TM
I/C SOL MON	—	—	
D/C SOL MON	—	—	
2346/B SOL MON	—	—	E
GEAR RATIO	Driving with 1GR	4.924	
	Driving with 2GR	3.194	F
	Driving with 3GR	2.043	
	Driving with 4GR	1.412	
	Driving with 5GR	1.000	G
	Driving with 6GR	0.862	
	Driving with 7GR	0.772	
ENGINE TORQUE	During driving	Changes the value according to the acceleration or deceleration.	H
ENG TORQUE D	During driving	Changes the value according to the acceleration or deceleration.	I
INPUT TRQ S	During driving	Changes the value according to the acceleration or deceleration.	J
INPUT TRQ L/P	During driving	Changes the value according to the acceleration or deceleration.	J
TRGT PRES L/P	Selector lever in "P" and "N" positions	490 kPa	
	Other than the above	490 – 1370 kPa	K
TRGT PRES TCC	Slip lock-up is active	0 – 600 kPa	
	Lock-up is active	600 kPa	L
	Other than the above	0 kPa	
TRGT PRES L/B	Low brake is engaged	1370 kPa	
	Low brake is disengaged	0 kPa	M
TRGT PRES FR/B	Front brake is engaged	1370 kPa	
	Front brake is disengaged	0 kPa	N
TRG PRE HLR/C	High and low reverse clutch is engaged	1370 kPa	
	High and low reverse clutch is disengaged	0 kPa	O
TRGT PRES I/C	Input clutch is engaged	1370 kPa	
	Input clutch is disengaged	0 kPa	
TRGT PRES D/C	Direct clutch is engaged	1370 kPa	
	Direct clutch is disengaged	0 kPa	P
TRG PRE 2346/B	2346 brake is engaged	1370 kPa	
	2346 brake is disengaged	0 kPa	
SHIFT PATTERN	During normal driving (without shift changes)	FF	
VEHICLE SPEED	During driving	Approximately equals the speedometer reading.	

REAR OIL SEAL

< REMOVAL AND INSTALLATION >

[7AT: RE7R01A]

ADJUSTMENT AFTER INSTALLATION

Adjust A/T fluid level. Refer to [TM-317](#). "Adjustment".

- A
- B
- C
- TM**
- E
- F
- G
- H
- I
- J
- K
- L
- M
- N
- O
- P

TRANSMISSION ASSEMBLY

< UNIT DISASSEMBLY AND ASSEMBLY >

[7AT: RE7R01A]

82. Measure dimension "A" to make sure that torque converter is in proper position.

- B : Scale
- C : Straightedge

Dimension "A" : Refer to [TM-426, "Torque Converter"](#).

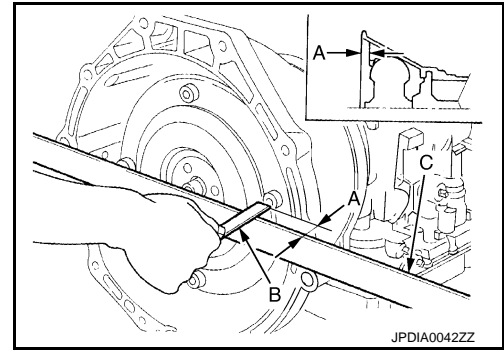

Inspection

INFOID:000000010839289

INSPECTION AFTER REMOVAL

Oil Pan

Check foreign materials in oil pan to help determine causes of malfunction. If the ATF is very dark, smells burned, or contains foreign particles, the frictional material (clutches, band) may need replacement. A tacky film that will not wipe clean indicates varnish build up. Varnish can cause valves, servo, and clutches to stick and can inhibit pump pressure.

- **If frictional material is detected, perform A/T fluid cooler cleaning. Refer to [TM-318, "Cleaning"](#).**

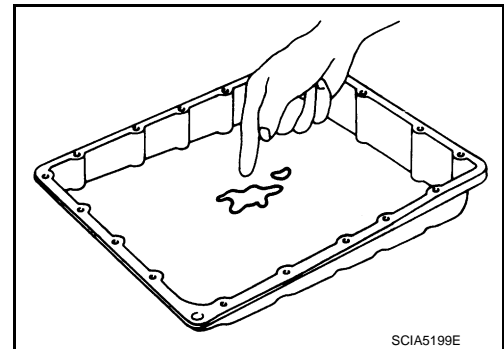

Torque Converter

Check torque converter one-way clutch using a check tool as shown at figure.

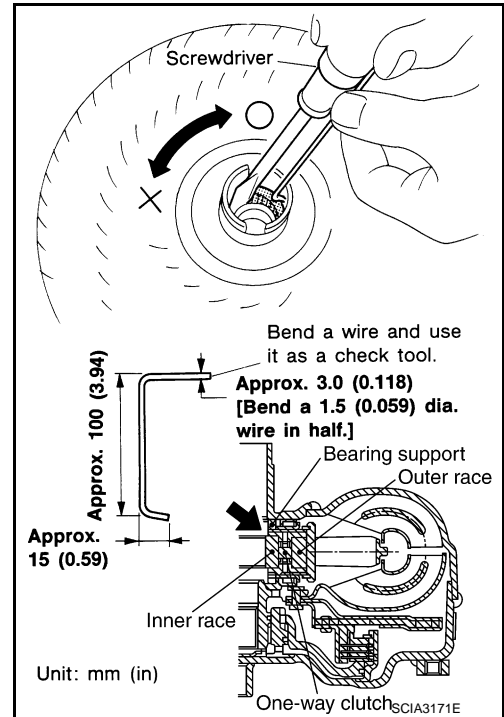

1. Insert a check tool into the groove of bearing support built into one-way clutch outer race.
2. When fixing bearing support with a check tool, rotate one-way clutch spline using a screwdriver.
3. Make sure that inner race rotates clockwise only. If not, replace torque converter assembly.



1st One-way Clutch

DIAGNOSIS SYSTEM (METER)

< SYSTEM DESCRIPTION >

Display item [Unit]	MAIN SIGNALS	Description
SYNC MODE [On/Off]		This item is displayed, but cannot be monitored.
PKB SW [On/Off]		Status of parking brake switch.
BUCKLE SW [On/Off]		Status of seat belt buckle switch (driver side).
BRAKE OIL SW [On/Off]		Status of brake fluid level switch.
A/C AMP CONN [On/Off]		Status of A/C auto amp. connection recognition signal.
ENTER SW [On/Off]		Status of  (ENTER) switch.
SELECT SW [On/Off]		Status of  (SELECT) switch.
MT SYNC REV SW [On/Off]		Status of S-MODE switch.
DISTANCE [km]		Value of possible driving distance calculated by combination meter.
OUTSIDE TEMP [°C or °F]		Ambient air temperature value converted from ambient sensor signal received from ambient sensor. NOTE: This may not match with the temperature value indicated on the information display. (Because the information display value is a corrected value from the ambient sensor input value.)
FUEL LOW SIG [On/Off]		Status of fuel level low warning signal to output to AV control unit via CAN communication.
BUZZER [On/Off]	X	Buzzer status (in the combination meter) is detected from the buzzer output signal received from each unit via CAN communication and the warning output condition of the combination meter.

NOTE:

Some items are not available according to vehicle specification.

WARNING HISTORY

- Stores histories when warning/indicator lamp is turned on.
- “Warning History” indicates the “TIME” when the warning/ indicator lamp is turned on.
- The “TIME” above is:
 - 0: The condition that the warning/indicator lamp has been turned on 1 or more times after starting the engine and waiting for 30 seconds.
 - 1 - 39: The number of times the engine was restarted after the 0 condition.
 - NO Warning History: Stores NO (0) turning on history of warning/indicator lamp.

NOTE:



- Warning History is not stored for approximately 30 seconds after the engine starts.
- Brake warning lamp does not store any history when the parking brake is applied or the brake fluid level gets low.

Display Item

Display item	Description
ABS W/L	Lighting history of ABS warning lamp.
VDC/TCS IND	Lighting history of VDC OFF indicator lamp.
SLIP IND	Lighting history of VDC warning lamp.
BRAKE W/L	Lighting history of brake warning lamp.
DOOR W/L	Lighting history of door warning.
OIL W/L	Lighting history of oil pressure warning lamp.

BCM (BODY CONTROL MODULE)

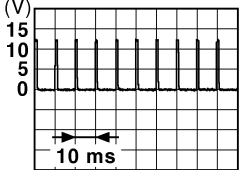
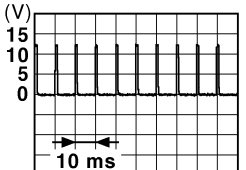
< ECU DIAGNOSIS INFORMATION >

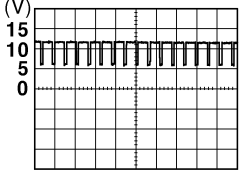
Terminal No. (Wire color)		Description		Condition		Value (Approx.)
+	-	Signal name	Input/ Output			
129*2 (O)	Ground	Trunk lid opener cancel switch	Input	Trunk lid opener cancel switch	CANCEL	 <p style="text-align: right; font-size: small;">JPMA0012GB</p> <p style="text-align: center;">1.1 V</p>
					ON	0 V
130*7 (L)	Ground	Rear window defogger switch	Input	Ignition switch ON	Rear window defogger switch OFF	 <p style="text-align: right; font-size: small;">JPMA0012GB</p> <p style="text-align: center;">1.1 V</p>
					Rear window defogger switch ON	0 V
132 (Y)*1 (V)*2	Ground	Power window switch and soft top control unit communication	Input/ Output	Ignition switch ON		 <p style="text-align: right; font-size: small;">JPMA0013GB</p> <p style="text-align: center;">10.2 V</p>
					Ignition switch OFF or ACC	12 V
133 (G)	Ground	Push-button ignition switch illumination	Output	Push-button ignition switch illumination	ON (Tail lamps ON)	<p style="text-align: center;">NOTE: The pulse width of this wave is varied by the illumination brightening/dimming level.</p>  <p style="text-align: right; font-size: small;">JPMA0159GB</p>
					OFF	0 V
134 (GR)	Ground	LOCK indicator lamp	Output	LOCK indicator lamp	OFF	Battery voltage
					ON	0 V
137 (P)	Ground	Receiver and sensor ground	Input	Ignition switch ON		0 V
138 (V)	Ground	Receiver and sensor power supply	Output	Ignition switch	OFF	0 V
					ACC or ON	5.0 V

A
B
C
D
E
F
G
H
I
J
K
L
M
O
P

WCS

C1716, C1717, C1718, C1719 TIRE PRESSURE SENSOR

< DTC/CIRCUIT DIAGNOSIS >

[REGULAR GRADE]

Special Repair Requirement

INFOID:000000010838237

1.CHECK TIRE PRESSURE

Check all tires for tire pressures. Refer to [WT-54, "Tire Air Pressure"](#).

Does all tire pressure data meet the specification?

YES >> GO TO 2.

NO >> Inspect or repair the tires or wheels and adjust the tire pressure to the specification.

2.PERFORM ID REGISTRATION

Perform ID registration. Refer to [WT-22, "Work Procedure"](#).

>> END

CLICK HERE TO **DOWNLOAD** THE COMPLETE MANUAL

- Thank you very much for reading the preview of the manual.
- You can download the complete manual from: www.heydownloads.com by clicking the link below



- Please note: If there is no response to CLICKING the link, please download this PDF first and then click on it.

CLICK HERE TO **DOWNLOAD** THE COMPLETE MANUAL