

SERVICE MANUAL

2015



ZR 120



www.arcticcat.com

CLICK HERE TO **DOWNLOAD** THE COMPLETE MANUAL

- Thank you very much for reading the preview of the manual.
- You can download the complete manual from: www.heydownloads.com by clicking the link below



- Please note: If there is no response to CLICKING the link, please download this PDF first and then click on it.

CLICK HERE TO **DOWNLOAD** THE COMPLETE MANUAL

- At this point, scribe a line at the front of the engine and measure the distance between the crankshaft and the driveshaft. Record the measurement for installing purposes.

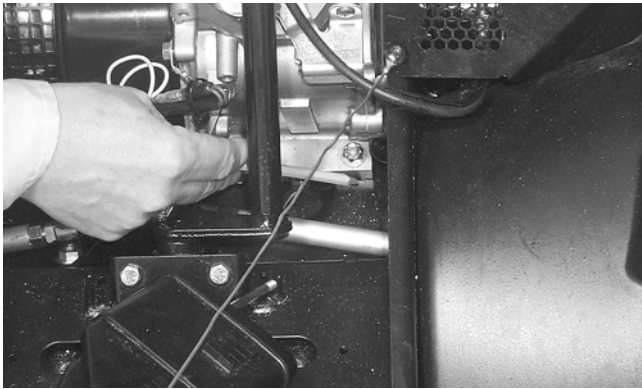

A048

- Lay the snowmobile on its side.

■NOTE: A piece of cardboard should be used to protect the finish.

- Using a flat-blade screwdriver, remove the four belly pan plugs covering the engine mounting cap screws; then remove the cap screws and lock nuts.

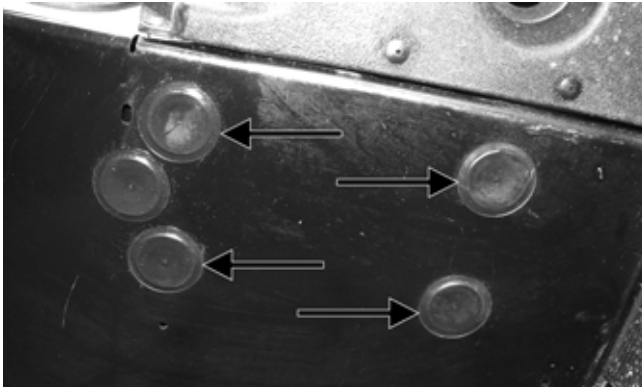

IO061A

■NOTE: The front center plug is to access the oil drain plug.

- Place the snowmobile in the upright position; then on the left-hand side of the engine, remove the three cap screws securing the engine and brake bracket to the front end.

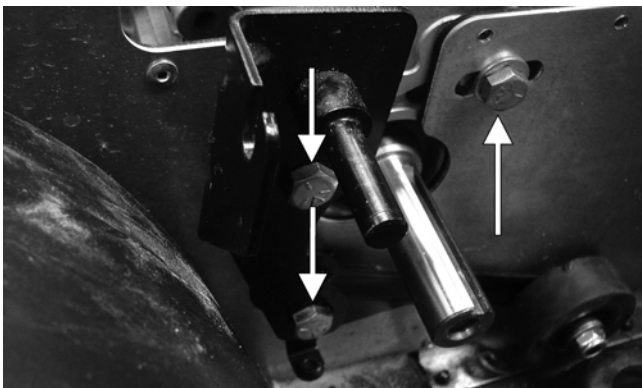

IO062A

- Remove the engine from the engine compartment.

Disassembling

- Remove the oil drain plug and drain the oil; then install the oil plug and tighten securely.



IO063

- Remove the cover from the air cleaner case; then disconnect the breather hose and remove the filter and retaining plate.

■NOTE: The retaining plate is directional.

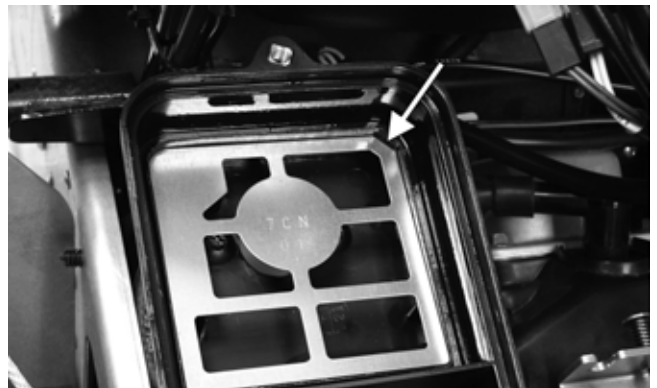

IO056A

- Remove the two cap screws securing the air cleaner case to the intake tube; then remove the cap screw and lock nut securing the case to the throttle cable bracket, remove the air cleaner case and account for the intake tube gasket.

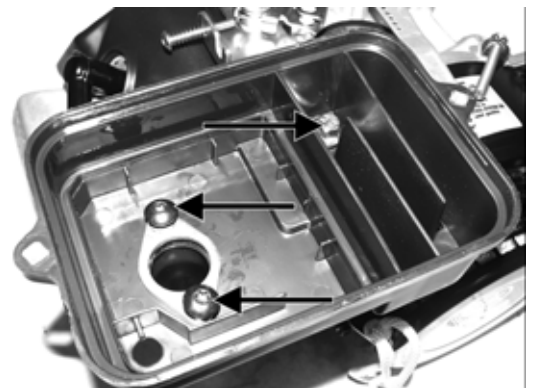

IO064A

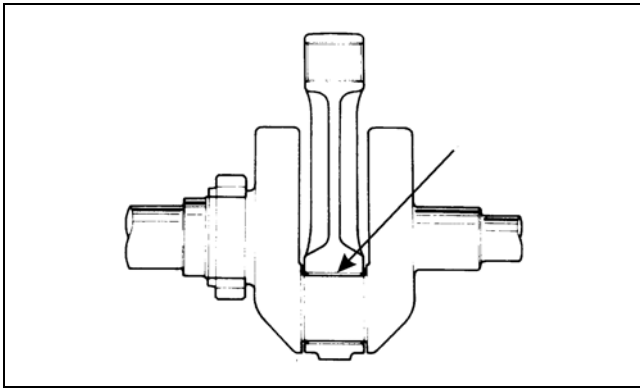

GEN-0039

CARBURETOR INSULATOR PLATE

1. Inspect for cracks, scoring, pitting, imperfections, or warping.
2. Inspect the sealing surfaces for trueness by placing each on the surface plate covered with #400 grit wet-or-dry sandpaper. Using light pressure, move both sides in a figure eight motion. Inspect the sealing surfaces for any indication of high spots or warping. Correct high spots by continuing to move each side in a figure eight motion. Warped components must be replaced.

CRANKSHAFT BEARINGS

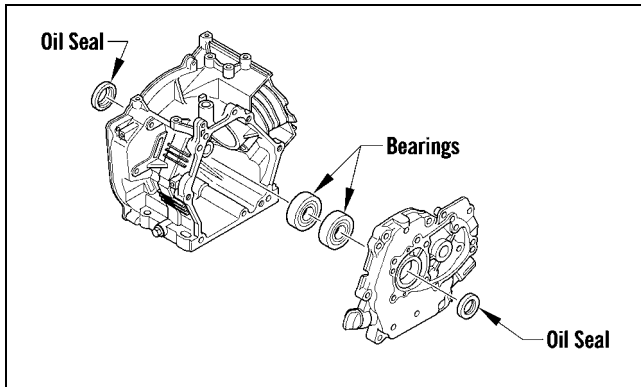

0744-992

Removing

1. Using a flat-blade screwdriver, carefully work the oil seal from side-to-side out of the crankcase and cover.
2. Using a suitable press and with the crankcase or crankcase cover secured into position, carefully heat the case; then press the bearings out of the case.

CAUTION

Never reuse the crankshaft bearings. If the bearings have been pressed out of the crankcase or crankcase cover, they must be discarded.

■NOTE: Thoroughly clean the bearing areas of the crankcase and crankcase cover and inspect for any nicks or imperfections of the bearing bosses of the case.

Installing

1. Secure the crankcase and press the new bearing into the boss of the crankcase and crankcase cover.

CAUTION

When installing the new bearings, always press against the outside race of the bearing.

2. With the bearings installed and using a suitable seal driver, install the oil seals with the spring side of the seal facing the bearing; then coat the wear surfaces of the seals with a film of grease.

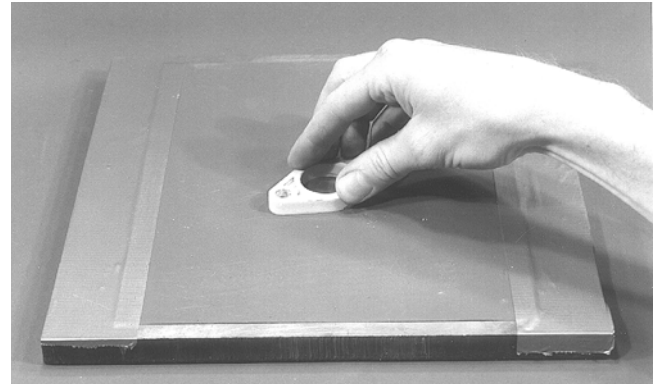

A932

CAUTION

Water or parts-cleaning solvent must be used in conjunction with the wet-or-dry sandpaper or damage to the sealing surfaces may result.

Assembling

■NOTE: The use of new gaskets and seals is recommended when assembling the engine.

■NOTE: Prior to assembling the engine, use parts cleaning solvent and compressed air and thoroughly clean the threaded holes of the crankcase and cylinder and head to properly tighten.

WARNING

Always wear safety glasses when drying components with compressed air.

■NOTE: When the use of a lubrication is indicated, use clean engine oil.

1. Lubricate the piston pin, connecting rod, and piston pin bore with engine oil; then install the piston to the connecting rod and secure the piston pin with the circlips directed either up or down.

- Remove the float pin (D) securing the float (E) to the carburetor body; then remove the float and needle jet assembly (F).
- Remove the main jet (G) and the nozzle (H) from the carburetor tower.

CLEANING

CAUTION

DO NOT place any non-metallic components in parts-cleaning solvent or carburetor cleaner because damage or deterioration will result.

- Place all metallic components in a wire basket and submerge in carburetor cleaner.
- Soak for approximately 30 minutes; then rinse with fresh parts-cleaning solvent.
- Wash all non-metallic components with soap and water. Rinse thoroughly.
- Dry all components with compressed air only making sure all holes, orifices, and channels are unobstructed.
- Blow compressed air through all hoses to remove any obstructions.

⚠ WARNING

Always wear safety glasses when drying components with compressed air.

CAUTION

DO NOT use wire or small drill bits to clean carburetor orifices, holes, or channels. Distorted or damaged orifices, holes, or channels can result in poor carburetor operation.

INSPECTING

- Inspect the mixing body and jet orifices for cracks, nicks, stripped threads, and any other imperfections in the casting.
- Inspect the float for perforations or damage.
- Inspect the gaskets for distortion, tears, or noticeable damage.
- When applicable, inspect the idle fuel adjuster screw, needle jet assembly, and pilot jet for wear, damage, or distortion.
- Inspect the nozzle and main jet for obstructions or damage.
- Inspect the carburetor insulator for damage, cracks, and tightness.

CAUTION

An air leak between the carburetor and engine will cause a lean condition and poor engine performance.

- Place the carburetor insulator on a surface plate covered with #400 grit wet-or-dry sandpaper. Move the insulator over the surface plate using a figure eight motion. The motion should produce an even wear pattern over the entire sealing area.

CAUTION

Water or parts-cleaning solvent must be used in conjunction with the wet-or-dry sandpaper or damage to the sealing surfaces may result.

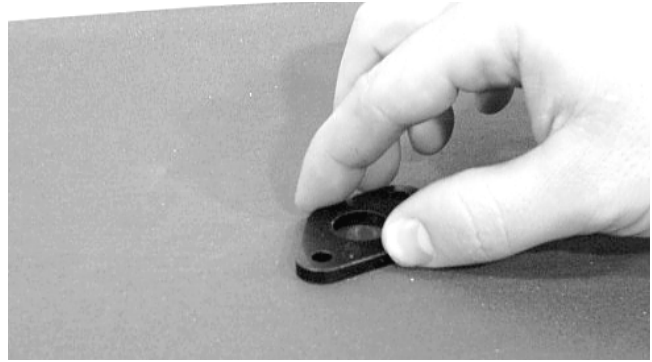

A739

- Inspect the condition of the throttle return spring.

CHECKING FLOAT HEIGHT

- Remove the cap screw securing the float chamber; then remove the float chamber from the carburetor and account for the rubber gasket.
- With the carburetor in an upside-down position, lift the float so the tip of the float lightly contacts the float arm; then measure the float height from the body of the carburetor and under-side of the float. Measurement should be 0.63".

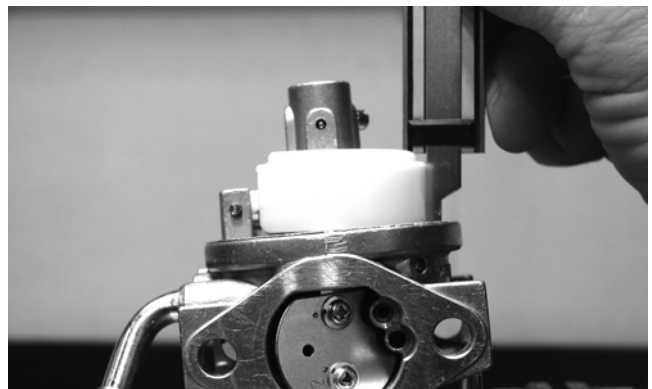

IO108

CAUTION

Do not bend the float in an attempt to adjust the height. Correct float height is obtained by replacing the needle jet assembly and/or the float.

3. Place the upper idler wheel assembly into position in the tunnel; then secure with cap screws. Tighten securely.
4. Install the skid frame (see Rear Suspension section).
5. Place the snowmobile in the upright position.
6. Place the key on the driveshaft; then slide the chain sprocket w/chain onto the driveshaft. Secure with a cap screw (coated with red Loctite #271) and washer. Tighten to 20 ft-lb.
7. Inspect the chain for proper engagement with the clutch sprocket and the chain sprocket.
8. Inspect that the chain tensioner assembly is in place and functioning properly.
9. Install the rear sprocket cover and secure with the self-tapping screws. Tighten securely.

■NOTE: At this point, proceed to TRACK TENSION sub-section.

TRACK TENSION

■NOTE: Track tension and track alignment are interrelated; therefore, always check both, even if only one adjustment seems necessary.

Track tension is directly related to the overall performance of the snowmobile. If the track is too loose, it may slap against the tunnel causing wear, or it may ratchet on the track drive sprockets. Arctic Cat recommends that the track tension be checked once a month and adjusted accordingly.

⚠ WARNING

Track tension must be properly maintained. Personal injury could result if a track is allowed to become excessively loose.

Checking

⚠ WARNING

DO NOT attempt to check or adjust track tension with engine running. Turn ignition key to the OFF position. Personal injury could result from contact with a rotating track.

1. Remove excess ice and snow buildup from the track, track drive sprockets, and the inside of the skid frame.
2. Place the rear of the snowmobile up on a safety stand high enough so the track is free of the floor.
3. Without exerting any pressure on the track, measure the distance between the bottom of the wear strip and the inside surface of the track. The measurement must be within specifications. If the measurement is not within 1/4-3/8 in., an adjustment is necessary.

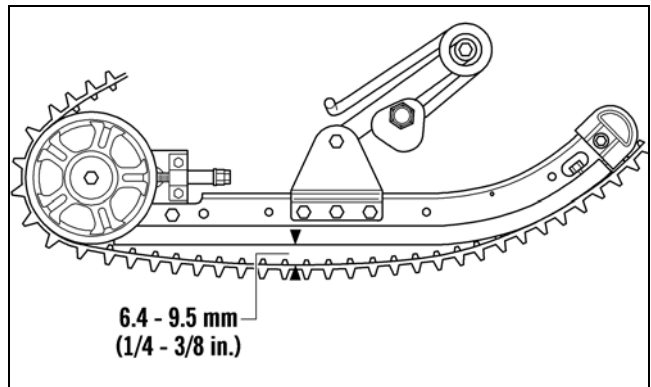

0744-945

Adjusting

1. Loosen the idler wheel cap screws.
2. Loosen the rear idler wheel adjusting bolt jam nuts.

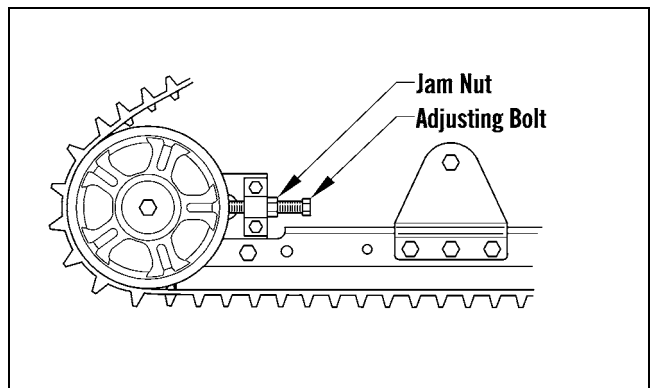

0744-947

■NOTE: To ensure proper track tension adjustment, perform all adjustments on both sides of the snowmobile.

3. If the deflection (distance between the bottom of the wear strip and the inside of the track) exceeds specifications, tighten the adjusting bolts to take up excessive slack in the track.
4. If the distance between the bottom of the wear strip and the inside surface of the track is less than specified, loosen the adjusting bolts to increase the slack in the track.
5. Check track alignment (see TRACK ALIGNMENT sub-section).
6. When proper track tension is obtained, tighten the adjusting bolt jam nuts against the axle housings.
7. Tighten the idler wheel cap screws securely.

■NOTE: Since track tension and track alignment are interrelated, always check both even if only one adjustment seems necessary.

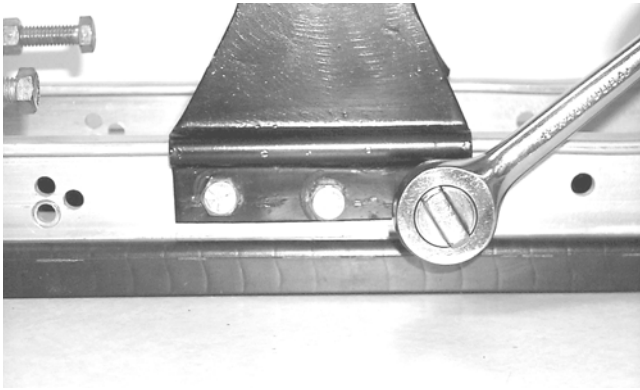

AO162

- Secure the rear arm to the support bracket with the cap screw. Tighten securely.

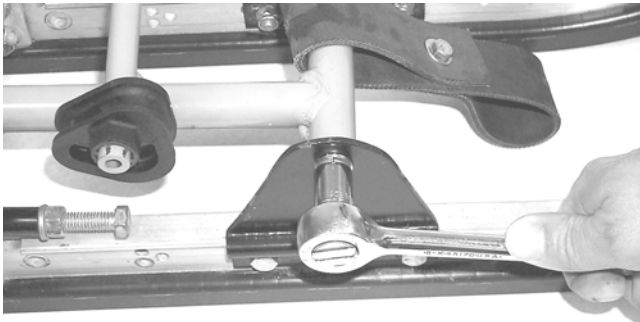

AO159

- Secure the cross-brace axle to the slide rail with the cap screw (threads coated with blue Loctite #243). Tighten to 20 ft-lb.



AO160

- Place the shock pad into position and secure with a solid rivet and push nut.

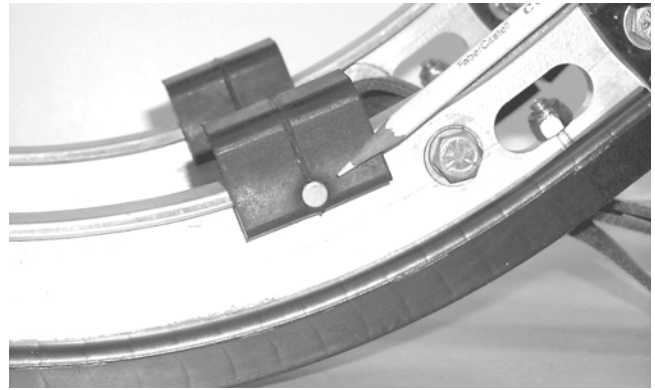

AO161

- Place the end cap onto the rail and secure with the cap screw, washers, and lock nut. Tighten to 78 in.-lb.

Installing Skid Frame

- Place a piece of cardboard on the floor to protect against scratching and tip the snowmobile onto one side.
- Pull the track away from the tunnel and spread open; then place the skid frame into the track.
- Position the front of the skid frame into the tunnel and align the front axle with the appropriate mounting holes in the tunnel. Secure the axle to the tunnel with the cap screws (coated with blue Loctite #243). Thread the cap screws in only half way. **DO NOT TIGHTEN AT THIS TIME.**

■ **NOTE:** To aid in centering the rear arm with the holes in the tunnel, position the skid frame and track at a 45° angle to the bottom of the tunnel.

- Align the rear idler axle with the appropriate mounting holes in the tunnel. Secure the axle to the tunnel with the cap screws (coated with blue Loctite #243). Thread the cap screws in only half way. **DO NOT TIGHTEN AT THIS TIME.**
- Align the rear arm with the holes in the arm support bracket. Secure the arm to the bracket with the cap screws (threads coated with blue Loctite #243). Tighten to 20 ft-lb.
- Place the snowmobile in the upright position.
- Securely tighten all mounting hardware (from steps 3 and 4) to 20 ft-lb.
- Check track tension; adjust as necessary (see Track and Driveshaft section).

CLICK HERE TO **DOWNLOAD** THE COMPLETE MANUAL

- Thank you very much for reading the preview of the manual.
- You can download the complete manual from: www.heydownloads.com by clicking the link below



- Please note: If there is no response to CLICKING the link, please download this PDF first and then click on it.

CLICK HERE TO **DOWNLOAD** THE COMPLETE MANUAL