

**60C**

**70C**

**90C**

# **SERVICE MANUAL**



**LIT-18616-02-66**

**6H2-28197-1F-11**

CLICK HERE TO **DOWNLOAD** THE COMPLETE MANUAL

- Thank you very much for reading the preview of the manual.
- You can download the complete manual from: [www.heydownloads.com](http://www.heydownloads.com) by clicking the link below



- Please note: If there is no response to CLICKING the link, please download this PDF first and then click on it.

CLICK HERE TO **DOWNLOAD** THE COMPLETE MANUAL

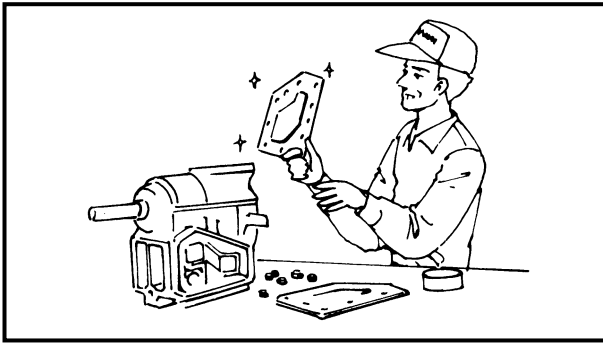

**3. Non-reusable items**

When reassembling, always use new gaskets, packing, O-rings, oil seals, split-pins and circlips, etc.

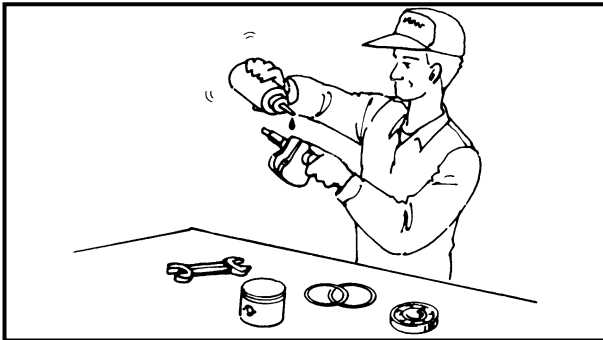

**DISASSEMBLY AND ASSEMBLY**

1. Clean parts with compressed-air when disassembling them.
2. Oil the contact surfaces of moving parts before assembly.

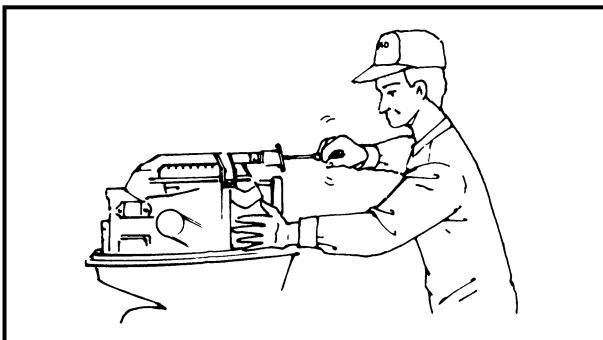

3. After assembly, check that moving parts operate normally.

4. Install bearings with the manufacturer's markings on the side exposed to view and liberally oil the bearings.
5. When installing oil seals, apply a light coating of water-resistant grease to the outside circumference.



Item	Unit	Model	
		60TR	70TR
Propeller: No. of blades × diameter × pitch  P: High performance propeller	in	K type (aluminum) 3 × 13-1/4 × 17 3 × 13 × 23 3 × 12-5/8 × 21 3 × 13 × 19 3 × 13-1/2 × 15 3 × 13-5/8 × 13	K type (stainless) 3 × 13 × 17 3 × 13 × 19 3 × 13 × 21 3 × 13 × 23 3 × 13 × 25 3 × 13-1/2 × 14 3 × 13-1/2 × 16
	in	P type (stainless) 3 × 14 × 20 3 × 14 × 24 3 × 14 × 28	

Item	Unit	Model	
		90TR	
Propeller: No. of blades × diameter × pitch  P: High performance propeller	in	K type (aluminum) 3 × 12-5/8 × 21 3 × 13 × 19 3 × 13 × 23 3 × 13-1/4 × 17 3 × 13-1/2 × 15 3 × 13-1/2 × 17 3 × 13-5/8 × 13 3 × 14 × 11	K type (stainless) 3 × 13 × 17 3 × 13 × 19 3 × 13 × 21 3 × 13 × 23 3 × 13 × 25 3 × 13-1/2 × 14 3 × 13-1/2 × 16
	in	P type (stainless) 3 × 14 × 20 3 × 14 × 22 3 × 14 × 24 3 × 14 × 26 3 × 14 × 28	



Parts to be tightened	Part name	Thread size	Q'ty		Tightening torque			Remarks
			60TR, 70TR	90TR	Nm	m • kg	ft • lb	
<b>POWER TRIM AND TILT:</b>								
Tilt cylinder end screw	Screw	—	1	1	90	9.0	65	
Trim cylinder end screw	Screw	—	2	2	160	16.0	115	
Fluid-level plug	Bolt	—	1	1	7	0.7	5.1	
Lock nut	Nut	—	6	6	15	1.5	11	
Valve spring mounting	Screw	—	2	2	4	0.4	2.9	
Valve lock screw	Screw	—	1	1	4	0.4	2.9	
Gear pump mounting	Bolt	M6	3	3	4	0.4	2.9	
Manual valve	Screw	—	1	1	3	0.3	2.2	
Main valve	Screw	—	2	2	11	1.1	8.0	

Nut (A)	Bolt (B)	General torque specifications		
		Nm	m•kg	ft•lb
8 mm	M5	5.0	0.5	3.6
10 mm	M6	8.0	0.8	5.8
12 mm	M8	18	1.8	13
14 mm	M10	36	3.6	25
17 mm	M12	43	4.3	31

**GENERAL TORQUE SPECIFICATIONS**

This chart specifies the torque for tightening standard fasteners with standard fasteners with standard clean dry ISO threads at room temperature. Torque specifications for special components or assemblies are given in applicable sections of this manual. To avoid causing warpage, tighten multifastener assemblies in crisscross fashion and in progressive stages a until the specified torque is reached.

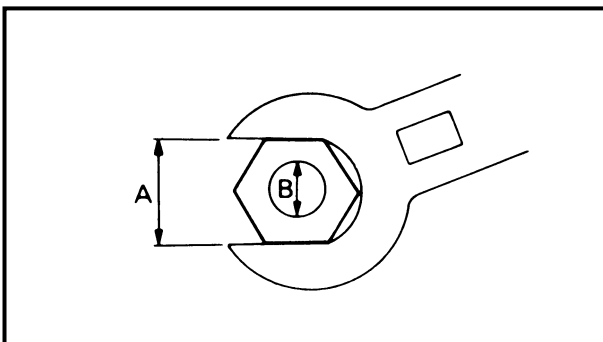

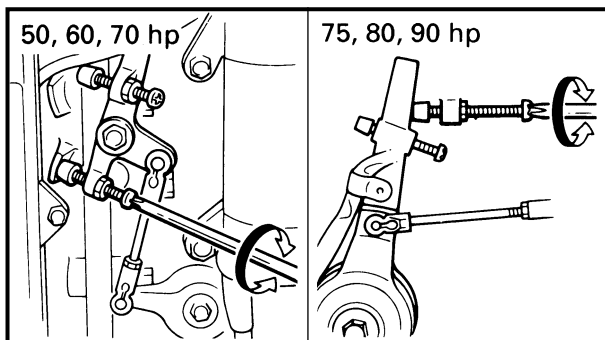
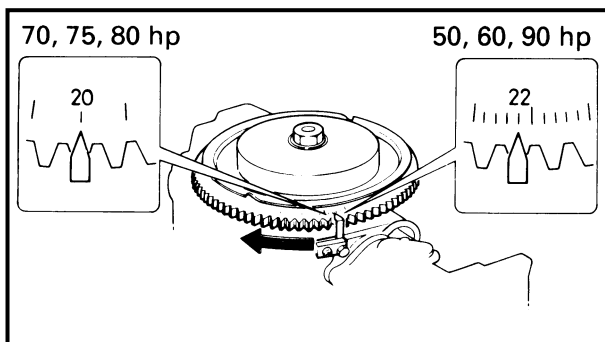

3. While keeping the stopper in contact with the full-advance adjusting screw, measure the full-retard ignition timing with the timing light.

If the timing is out of specification, adjust it by turning the full-advance adjusting screw.

**NOTE:** \_\_\_\_\_

When measuring the full-advance ignition timing, keep the specified engine speed.

	<b>Full-advance side engine speed:</b>
	<b>50, 60, 75, 80, 90 hp:</b> 5,000 ± 500 r/min
	<b>70 hp:</b> 5,500 ± 500 r/min

	<b>Full-advance side ignition timing:</b>
	<b>50, 60, 90 hp:</b> 22 ± 1° BTDC
	<b>70, 75, 80 hp:</b> 20 ± 1° BTDC

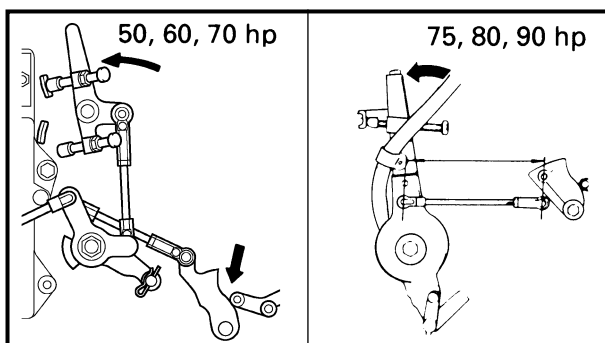
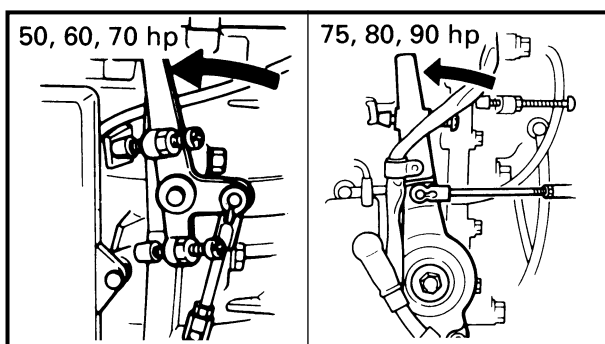

**PICK-UP TIMING ADJUSTMENT**

**NOTE:** \_\_\_\_\_

Engine idle speed should be adjusted properly before adjusting the pick-up timing.

1. Turn the magneto control lever to the full-retard position.
2. Bring the throttle cam to lightly contact the throttle lever roller. (The throttle valve should not open.) Adjust the accelerator link length and connect magneto control lever to the accelerator cam.

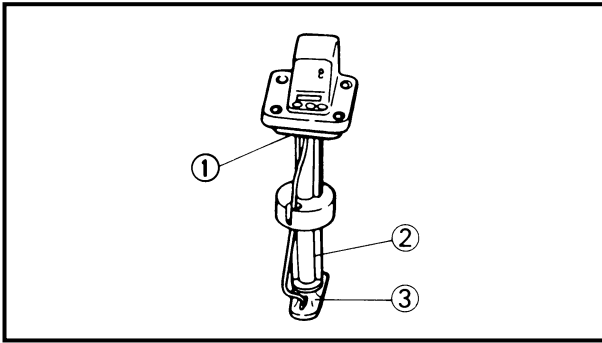

E21020-0

**FUEL METER COMPLETE**

1. Using a soft brush and solvent, clean the strainer on the end of the suction pipe and blow-dry it with compressed air.
2. Visually inspect the strainer for damage and replace the fuel meter complete if required.
3. Inspect the fuel meter components for cracks and replace the fuel meter complete if required.
4. Re-install the fuel meter complete with the rubber gasket to the fuel tank, ensuring that there are no leaks between the fuel meter and the fuel tank.

- ① Fuel meter assembly
- ② Suction pipe
- ③ Fuel strainer

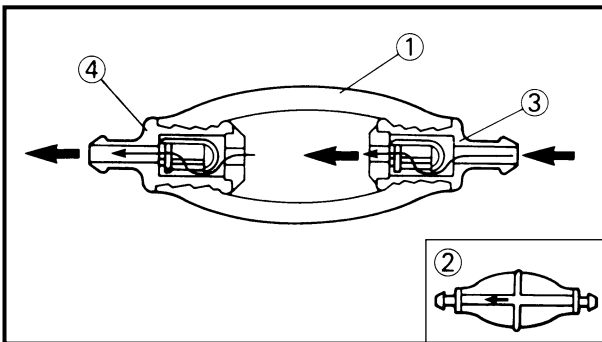

E21030-0

**PRIMING PUMP**

1. Visually inspect for cracks or breaks in the priming-pump and fuel-hoses and replace them if required.
2. Check the operation of the check-valve by blowing into the pump.

- ① Priming valve
- ② Arrow mark
- ③ Check valve (inlet)
- ④ Check valve (outlet)

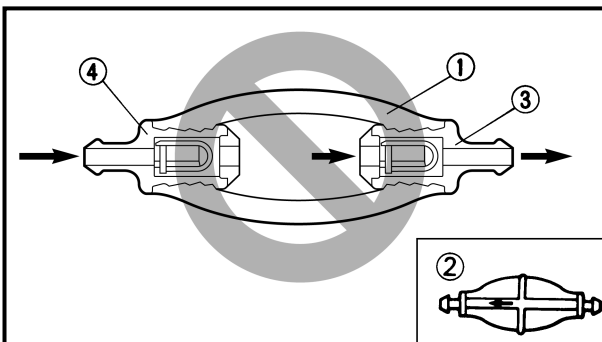

E21040-0

**FUEL FILTER**

1. After removing the nut and filter-cap, disassemble the fuel filter.
2. Visually inspect the filter body for cracks or damage to the thread and replace if required.

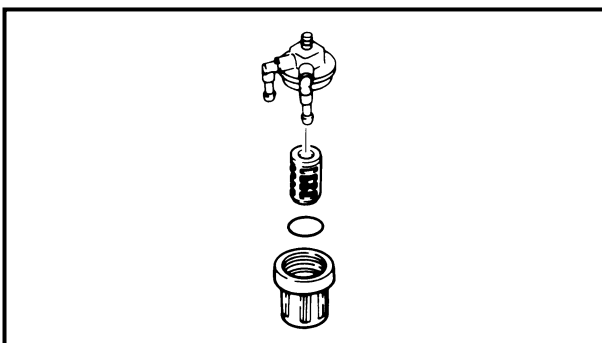

**OIL-INJECTION SYSTEM (Oil injection model)  
EXPLODED DIAGRAM**

- ① Oil level sensor
- ② Oil strainer
- ③ Strainer cover gasket
- ④ Oil injection pump assembly
- ⑤ Check valve
- ⑥ Oil tank
- ⑦ Special washer
- ⑧ Oil tank cap assembly
- ⑨ Hook
- ⑩ Filler tube

50, 60, 70 hp

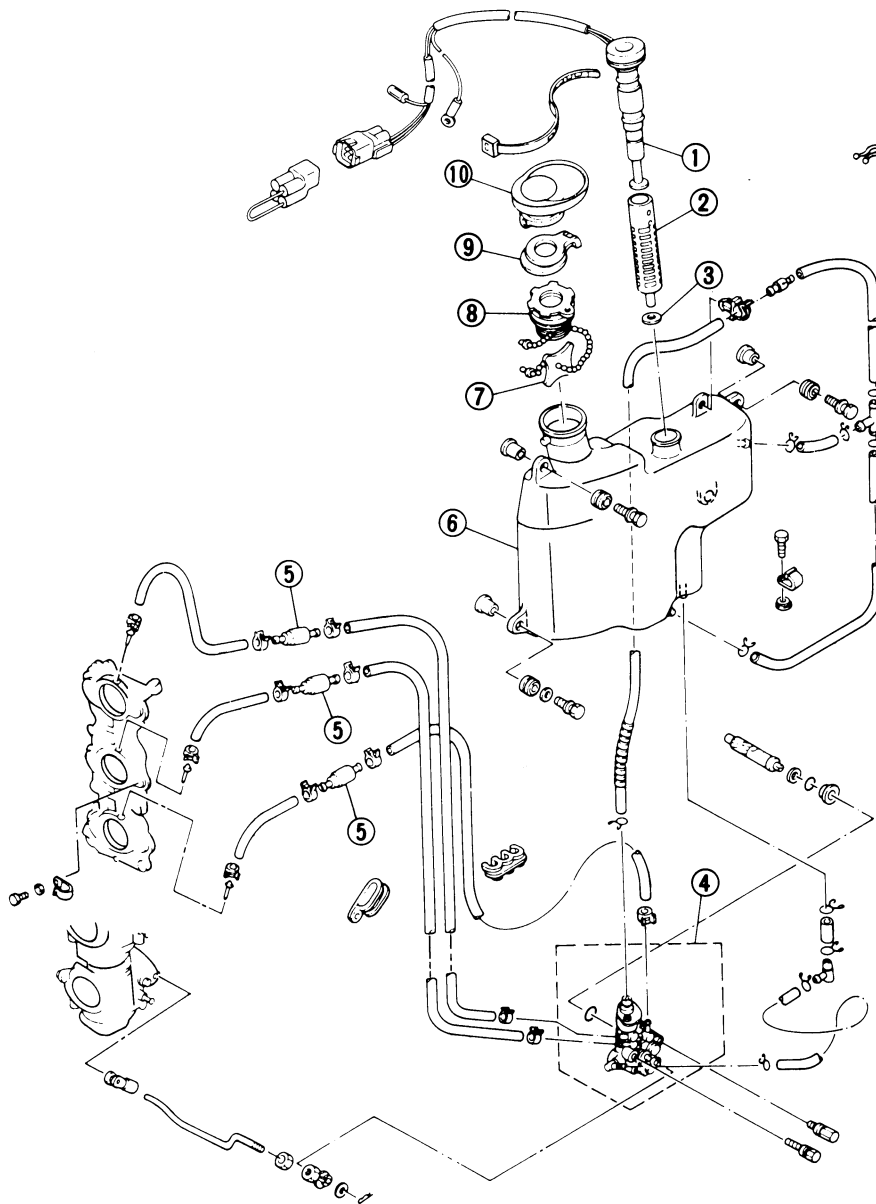



G50003-0

**DISASSEMBLY**

Referring to the exploded diagram, remove the following parts.

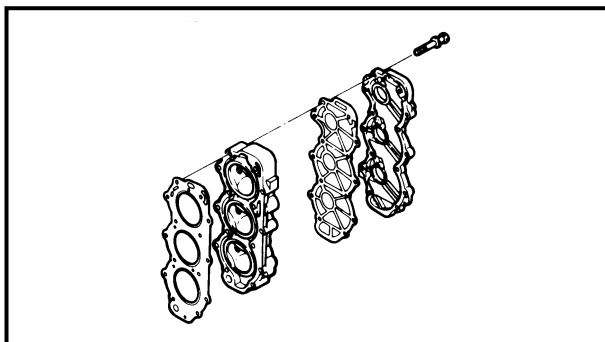

1. Cylinder head

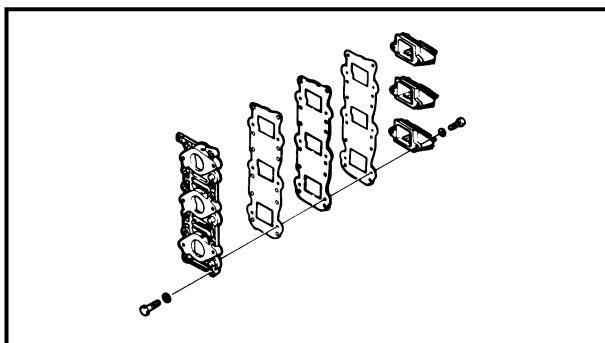

2. Intake manifold

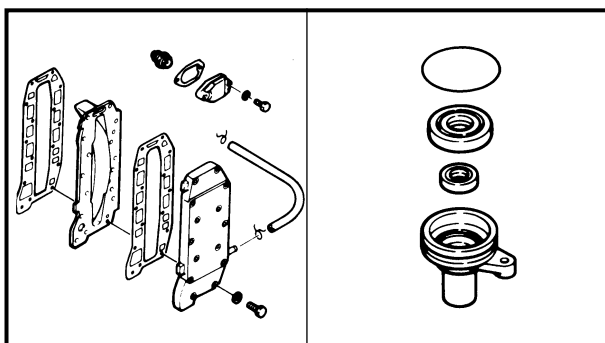

3. Exhaust cover and thermostat cover.

4. Oil seal housing

Using the oil seal remover, remove the oil seal one by one from the housing.

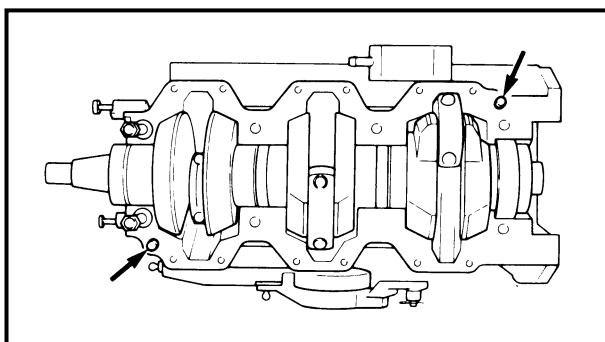

5. Crankcase

Remove the two dowel pins.

6. Crankshaft and connecting rod.  
(50, 60, 70 hp)

7. Connecting rod caps, needle bearings and crankshaft. (75, 80, 90 hp)

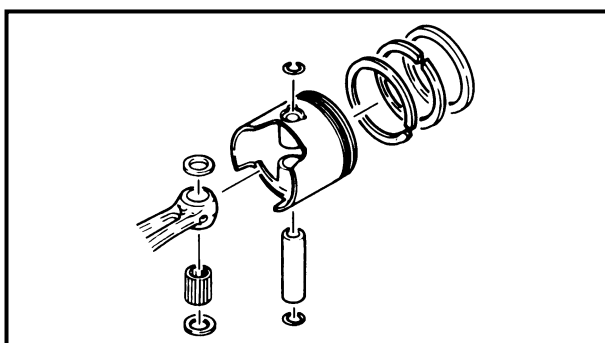

8. Piston and piston pin

9. Piston rings

Note the following points:

1. When disassembling the piston and piston pin, place a tray under the connecting rod to catch the needle bearings.

2. Only carry out exchange of the crankshaft bearing if the bearing is malfunctioning.



G73000-0\*

**SMALL END BEARINGS AND PISTON ASSEMBLY**

1. Count the small-end bearing needles.

**Number of needles per small end: 28-pcs.**

**CAUTION:** \_\_\_\_\_

**Do not use a mixture of new and used bearing needles in the same small end.**

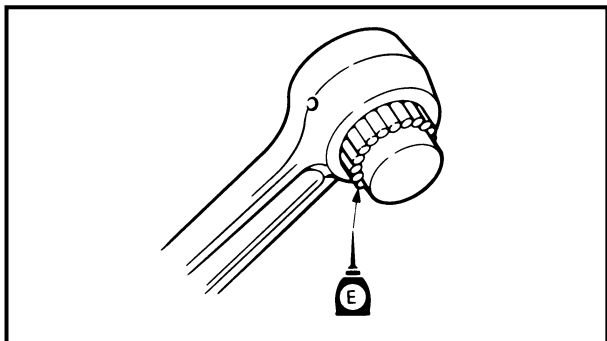

2. Using the special service tool, install the bearings in the connecting-rod small end and place washers on both sides.



**Small end bearing installer:**  
 50, 60, 70 hp:  
 YB-6287/90890-06527  
 75, 80, 90 hp:  
 YB-6107/90890-06527

**CAUTION:** \_\_\_\_\_

**The washer should be placed with their convex sides facing the piston.**

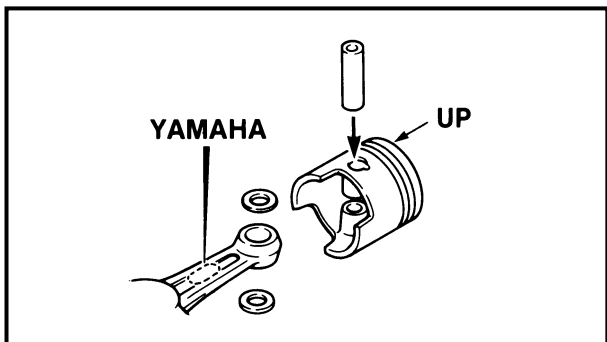
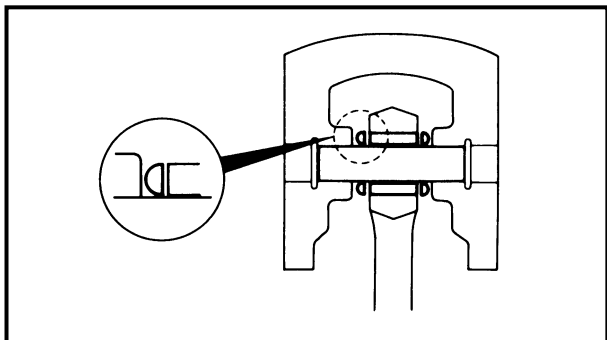

3. Insert the piston-pin into the piston.
4. Align the "UP" mark on the piston crown towards the crankshaft's tapered end. Install the piston in the connecting-rod small end, insert the piston-pin, then install new piston-pin clips.
5. Lubricate each bearing with 2-stroke outboard-motor oil.

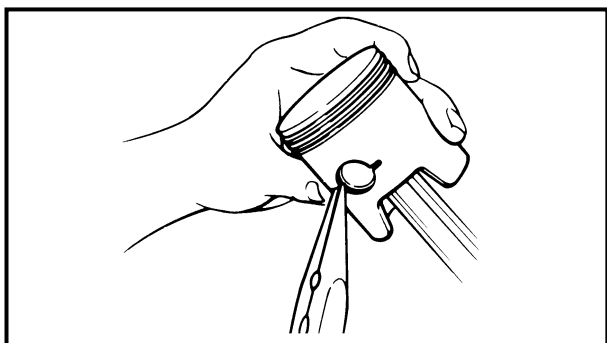

CLICK HERE TO **DOWNLOAD** THE COMPLETE MANUAL

- Thank you very much for reading the preview of the manual.
- You can download the complete manual from: [www.heydownloads.com](http://www.heydownloads.com) by clicking the link below



- Please note: If there is no response to CLICKING the link, please download this PDF first and then click on it.

CLICK HERE TO **DOWNLOAD** THE COMPLETE MANUAL

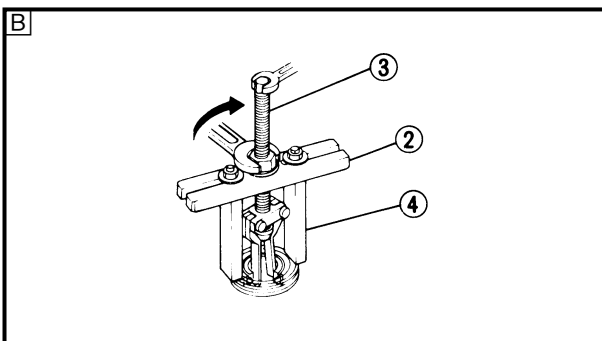
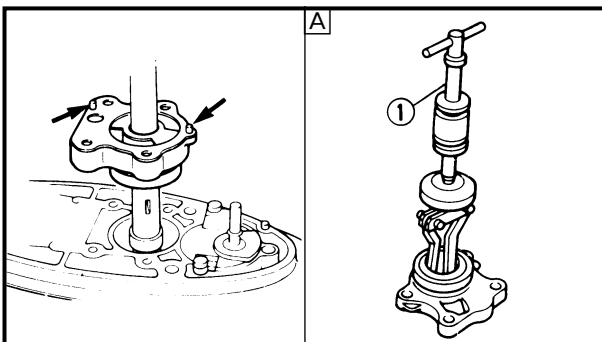
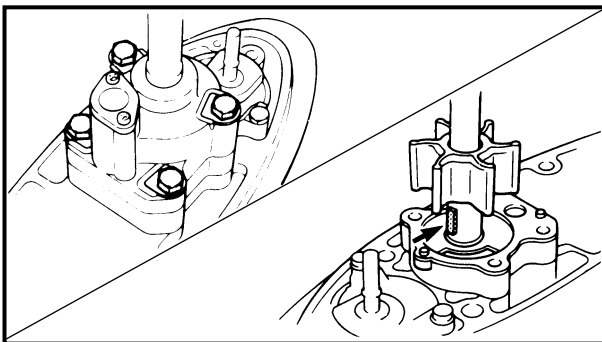
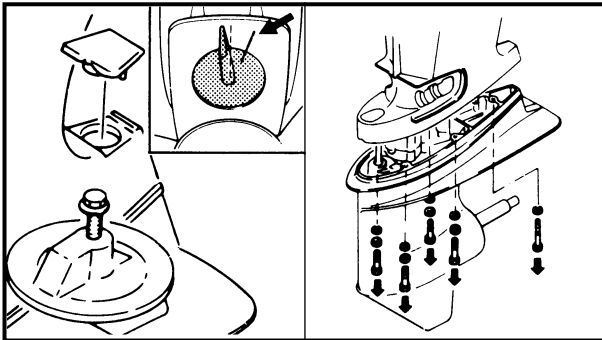
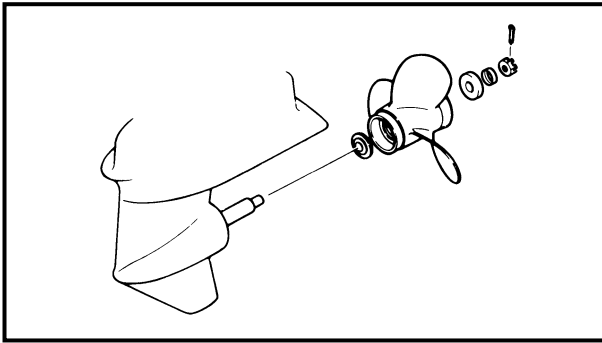
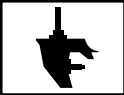

120001-0\*

**PREPARATION FOR REMOVAL**

1. Remove the nut, bushing, spacer, propeller and spacer from the propeller shaft.
2. Drain the gear oil by removing the plugs from the oil-filling hole and the oil-level hole. Be sure to remove the oil filling plug first.
3. Set the shift lever into neutral position.
4. Tilt up the lower unit and lock it with the tilt lock lever.
5. Remove the trim tab. Before removing it, put a mark indicating its position on the anticavitation plate.
6. Remove the bolts.

140007-0

**DISASSEMBLY**

1. Referring to the exploded diagram, remove the following parts.
  - 1) Water pump housing and insert cartridge
  - 2) Impeller and woodruff key
- 3) Oil-seal housing  
(Water pump housing)  
Remove the oil seals, if necessary

	<b>Slide hammer set:</b>
	<b>YB-6096 ①</b>
	<b>Stopper guide plate:</b>
	<b>90890-06501 ②</b>
	<b>Bearing puller:</b>
	<b>90890-06535 ③</b>
	<b>Stopper guide stand:</b>
	<b>90890-06538 ④</b>

**A** For USA and Canada

**B** Except for USA and Canada

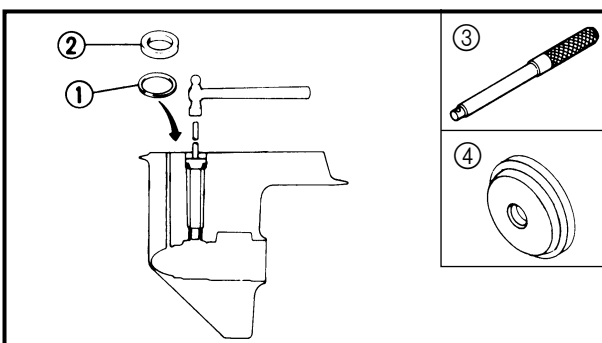
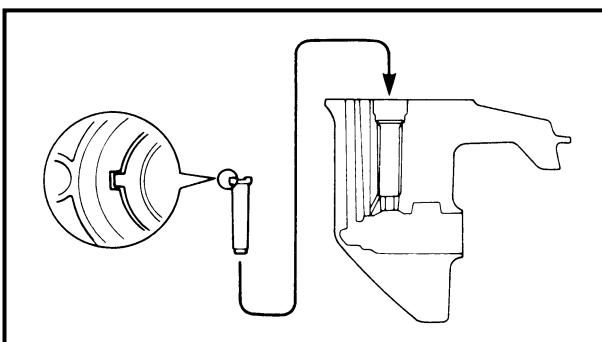
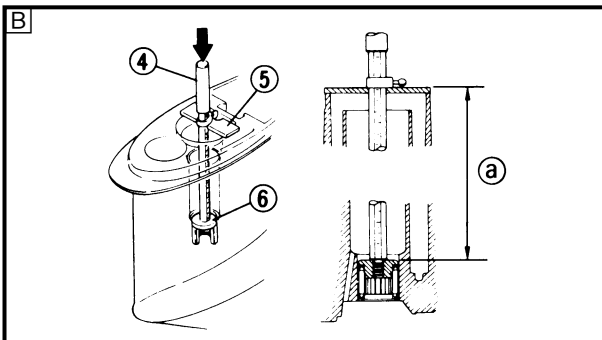
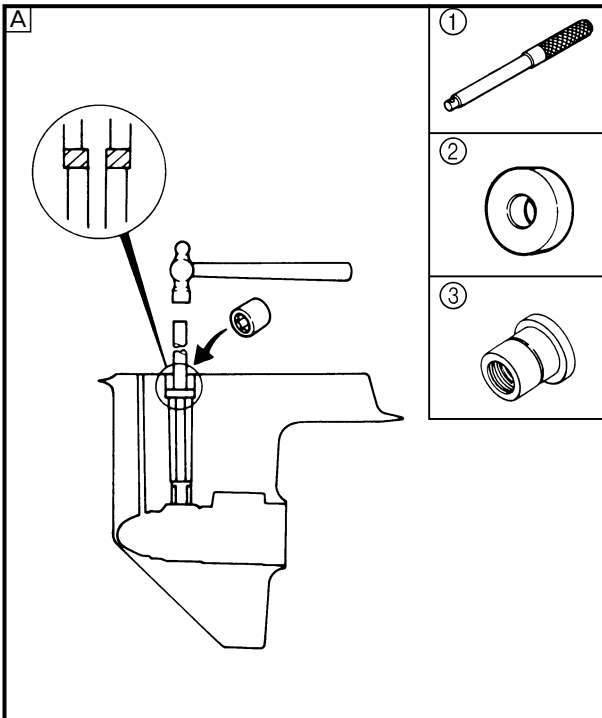

**GEAR CASE**

1. Install a new needle-bearing in position.

**NOTE:**

The needle bearing should be installed with the mark facing the flange side of attachment.

	<b>Driver rod:</b>	
	YB-6071.....	①
	<b>Needle bearing depth stop:</b>	
	YB-34473.....	②
	<b>Needle bearing attachment:</b>	
	YB-6155.....	③
	<b>Driver rod:</b>	
	90890-06602.....	④
	<b>Bearing depth plate:</b>	
	90890-06603.....	⑤
	<b>Needle bearing attachment:</b>	
	50 hp: 90890-06614 .....	⑥
60 ~ 90 hp: 90890-06611 .....	⑥	

	<b>Depth (a):</b>	
	50 hp	: 198.3 ~ 198.8 mm (7.81 ~ 7.83 in)
	60 ~ 90 hp	: 187.6 ~ 188.6 mm (7.39 ~ 7.43 in)

- A** For USA and Canada
- B** Except for USA and Canada

2. Align the drive-shaft sleeve locating-rib with the recess in the gear case and place the drive-shaft sleeve into the gear case.

3. Place the pinion-gear shim-pack ① in position and install the taper-roller bearing outer race ② on the shim-pack.

	<b>Drive rod:</b>	
	YB-6071/90890-06606 .....	③
	<b>Bearing outer race attachment:</b>	
	50 hp: 90890-06627 .....	④
60 ~ 90 hp:		
YB-6156/90890-06626 .....	④	

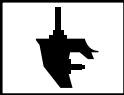

**NOTE:**

- Use a minimum number of shims to obtain the thickness equal or nearly equal to the calculation.
- Install the shims with the thicker one on the outer side.

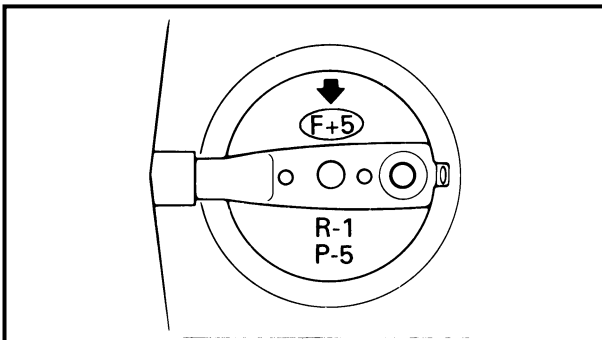
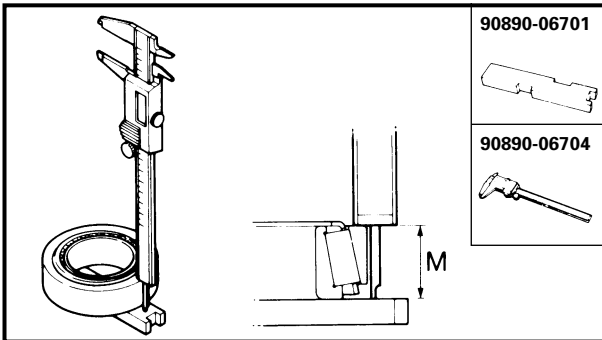
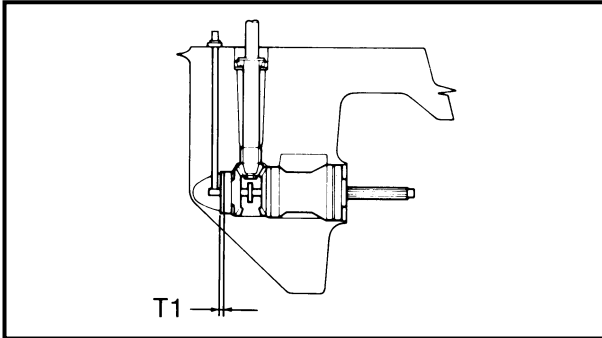

**Forward gear shim**

1. Find forward gear shim thickness (**T1**) by selecting shims until the specified measurement (**M**) with the special tool is obtained.

2. Using a digital caliper at the specified measurement (**M**) established above, measure the bearing height.

**Shim thickness (T1)=**  
 50 hp:  
 $22.70 \text{ mm} + F/100 \text{ mm} - M$   
 60 ~ 90 hp:  
 $24.50 \text{ mm} + F/100 \text{ mm} - M$

**Shimming plate:**  
 90890-06701  
**Digital caliper:**  
 90890-06704

3. **F** is the deviation of the lower case dimension from standard. It is stamped on the trim tab mounting surface of the lower case in 0.01 mm units. If the **F** mark is missing or unreadable, assume an **F** mark of "0" and check the backlash when the unit is assembled.

Example:

If **M** is "23.90 mm" **F** is "+5", then

$$T1 = 24.50 + 5/100 - 23.90 = 0.65$$

**Available shim thickness:**  
 0.10, 0.12, 0.15, 0.18, 0.30, 0.40  
 and 0.50 mm

**BRACKET UNIT  
EXPLODED DIAGRAM**

**MANUAL HANDLE**

**P60TH/60FEHTO\*1, P75TH/75CEHTO, 90AEHD\*2**

- |                      |                 |                                 |
|----------------------|-----------------|---------------------------------|
| ① Steering handle    | ⑥ Link assembly | ⑪ Main switch lead              |
| ② Bracket            | ⑦ Shift cable   | ⑫ Extension wire lead           |
| ③ Main switch        | ⑧ Cover         | ⑬ PTT switch (PTT model)        |
| ④ Engine stop switch | ⑨ Grip          | ⑭ Steering friction (PTT model) |
| ⑤ Throttle cable     | ⑩ Battery cable |                                 |

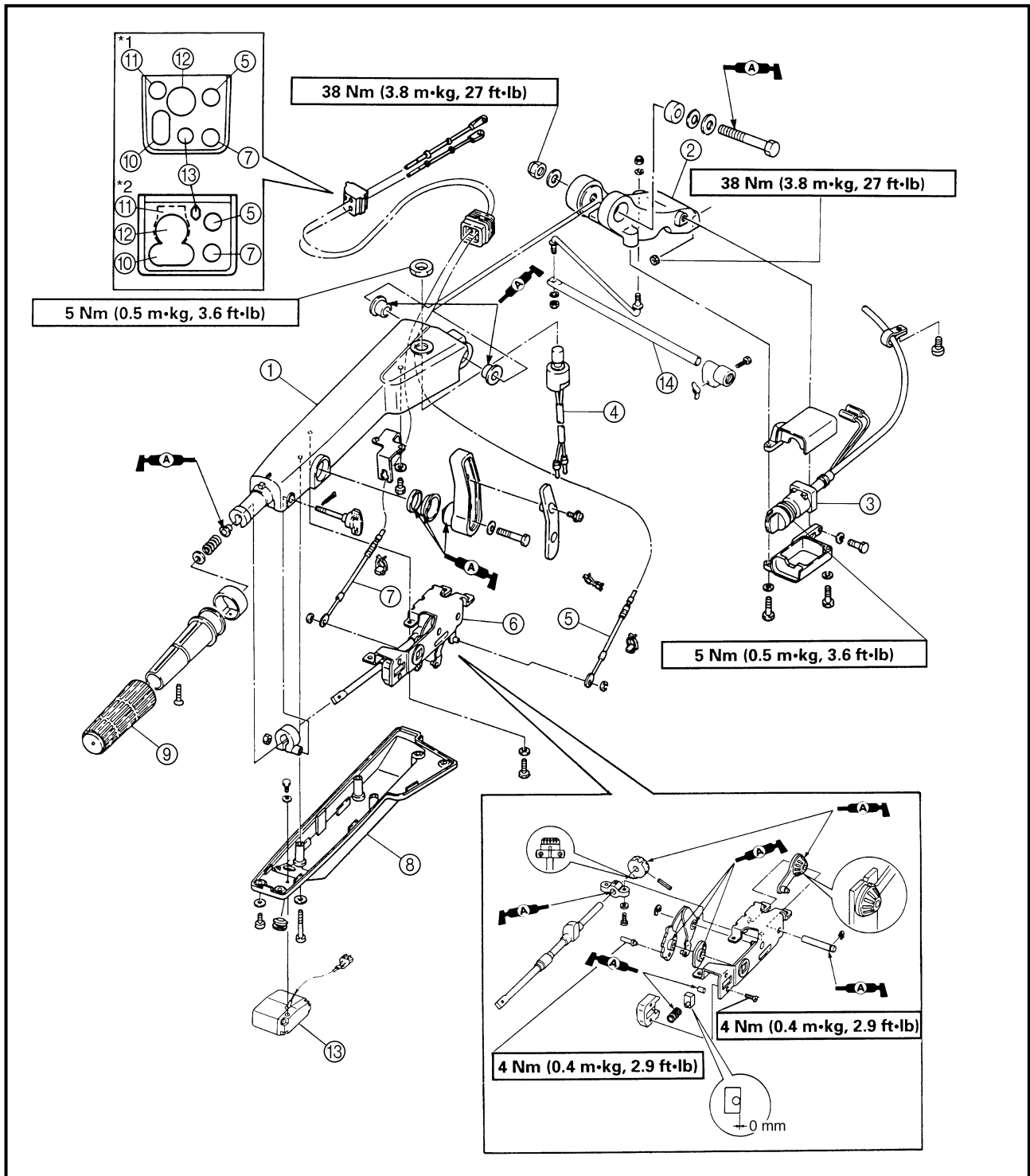

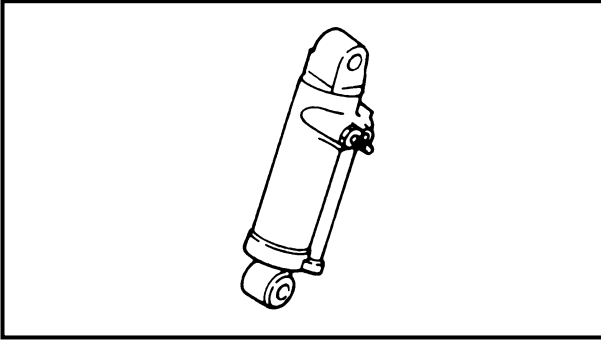

## HYDRAULIC TILT UNIT

### **⚠ WARNING**

This cylinder is highly pressurized. Therefore, never overhaul or damage it.

### INSPECTION

1. Inspect the tilt cylinder assembly for scratches or corrosion.  
If any scratches are found, replace the tilt cylinder assembly.

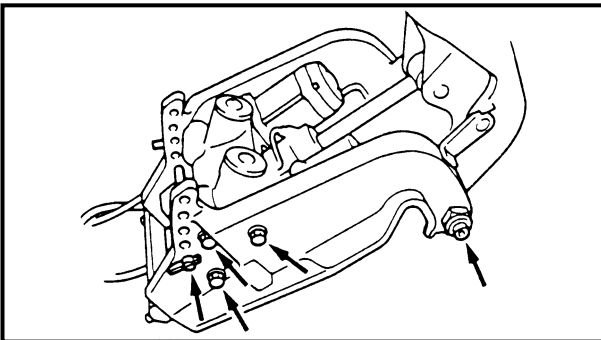

## POWER TRIM AND TILT UNIT REMOVAL

1. Disconnect the leads from the relay in the bottom cowling.
2. Remove the tilt-rod, bolts and nut, and the clamp-bracket.
3. Remove the circlip and the complete power trim and tilt unit.

- ① Trim down valve (0.2 kg/cm<sup>2</sup>)
- ② Trim down valve (1 kg/cm<sup>2</sup>)
- ③ Reservoir
- ④ Up-relief valve (100 kg/cm<sup>2</sup>)
- ⑤ Manual valve
- ⑥ Tilt cylinder
- ⑦ Absorber valve (180 kg/cm<sup>2</sup>)
- ⑧ Trim cylinder
- ⑨ Main valve (0.5 kg/cm<sup>2</sup>)
- ⑩ Down-relief valve (30 kg/cm<sup>2</sup>)
- ⑪ Gear pump
- ⑫ Power trim and tilt motor

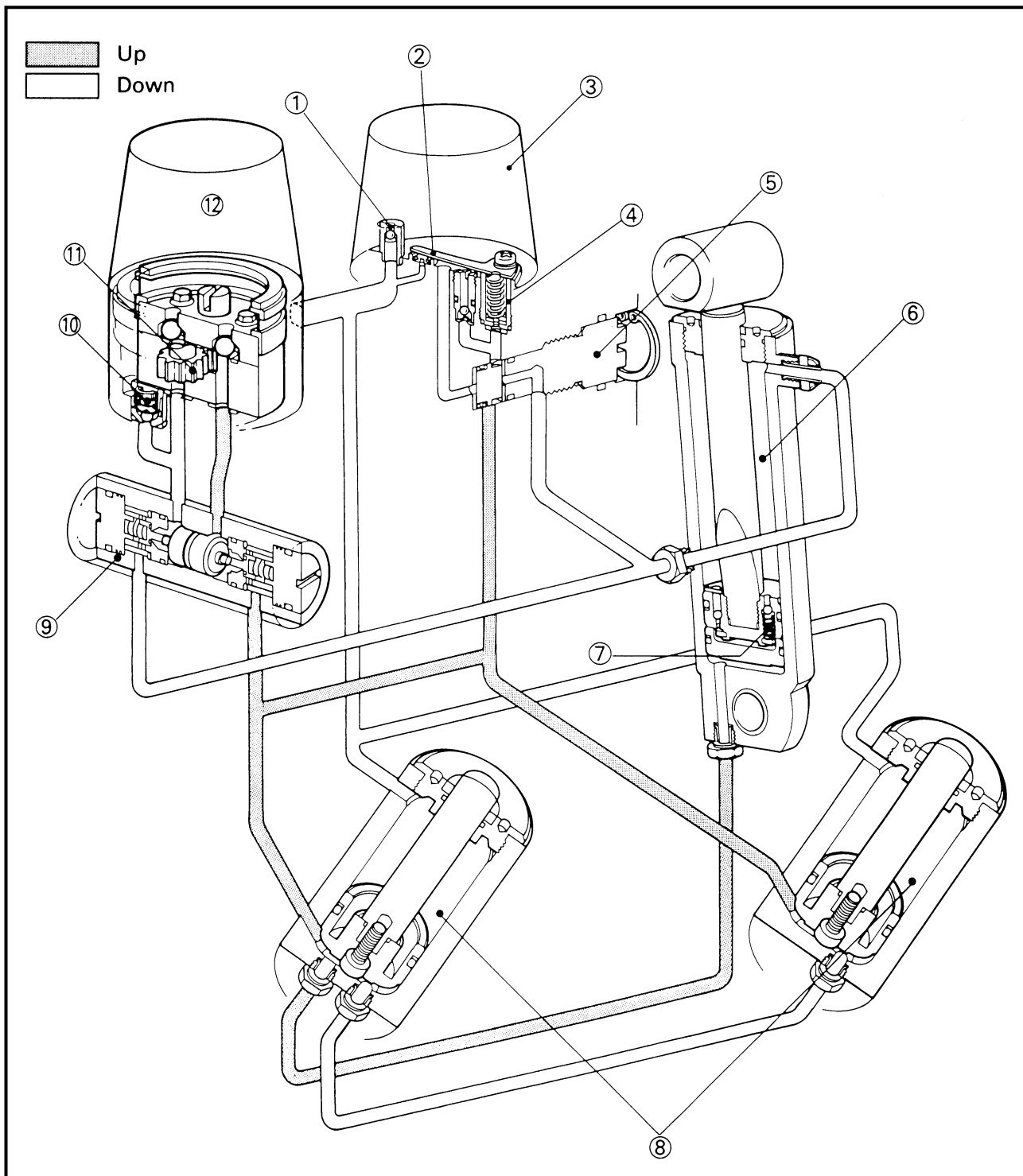

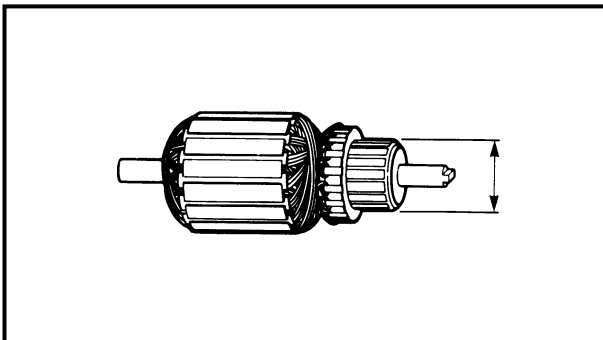
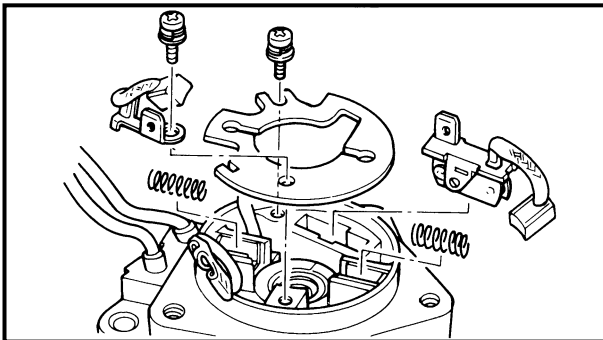
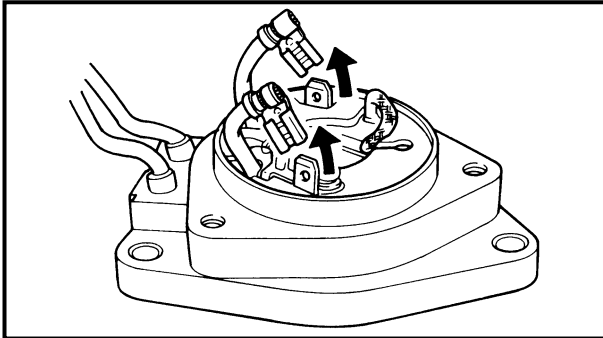
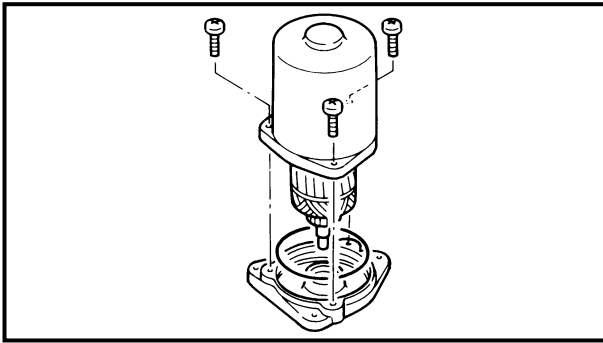

## POWER TRIM AND TILT MOTOR DISASSEMBLY

1. Loosen the screws and remove the stator, O-ring and the armature.
2. Disconnect the connector.
3. Loosen the screw and remove the brush, cover plate, circuit breaker and the spring.

K62001-0\*

## INSPECTION ARMATURE COIL

1. Visually inspect the commutator surface and if it shows signs of roughness, polish it with 600-grit wet-or-dry sandpaper.
2. Measure the outside diameter of the commutator by use of a vernier caliper. If the diameter is less than the specified minimum outside diameter, replace the whole armature.



**Armature minimum outside diameter:**

**Standard: 22 mm (0.87 in)**

**Minimum: 21 mm (0.83 in)**

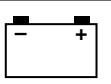

**75, 80, 90 hp**

- ① Crank position sensor coupler
- ② Fuel enrichment valve \*1
- ③ Clamp
- ④ Clamp
- ⑤ Wire harness coupler
- ⑥ Trim sensor coupler \*2
- ⑦ Oil level sensor coupler \*3
- ⑧ Clamp
- ⑨ Ground lead from power trim and tilt relay \*2
- ⑩ Ground lead from wire harness
- ⑪ Ground lead from rectifier/regulator
- ⑫ Charge coil coupler
- ⑬ Power trim and tilt relay coupler \*2
- ⑭ Pulsar coil coupler

- ⑮ Ground lead from starter relay
- ⑯ Ground lead from CDI unit
- ⑰ Lighting coil coupler
- A To electrothermal valve \*4
- B To trim sensor \*2
- C To power trim and tilt motor \*2
- D To oil level sensor \*3
- E To wire harness
- F To starter motor
- G To trailer switch \*2
- H To neutral switch \*5

- B : Black
- Br : Brown
- G : Green
- L : Blue
- Lg : Light green
- O : Orange
- P : Pink
- R : Red
- Sb : Sky blue
- W : White
- Y : Yellow

- \*1: For C75TR
- \*2: For PTT model
- \*3: For oil injection model
- \*4: Except for C75TR
- \*5: For P75TH/75CEHTO, 90AEHD, 90TR/90AETO, B90TR/90AETO

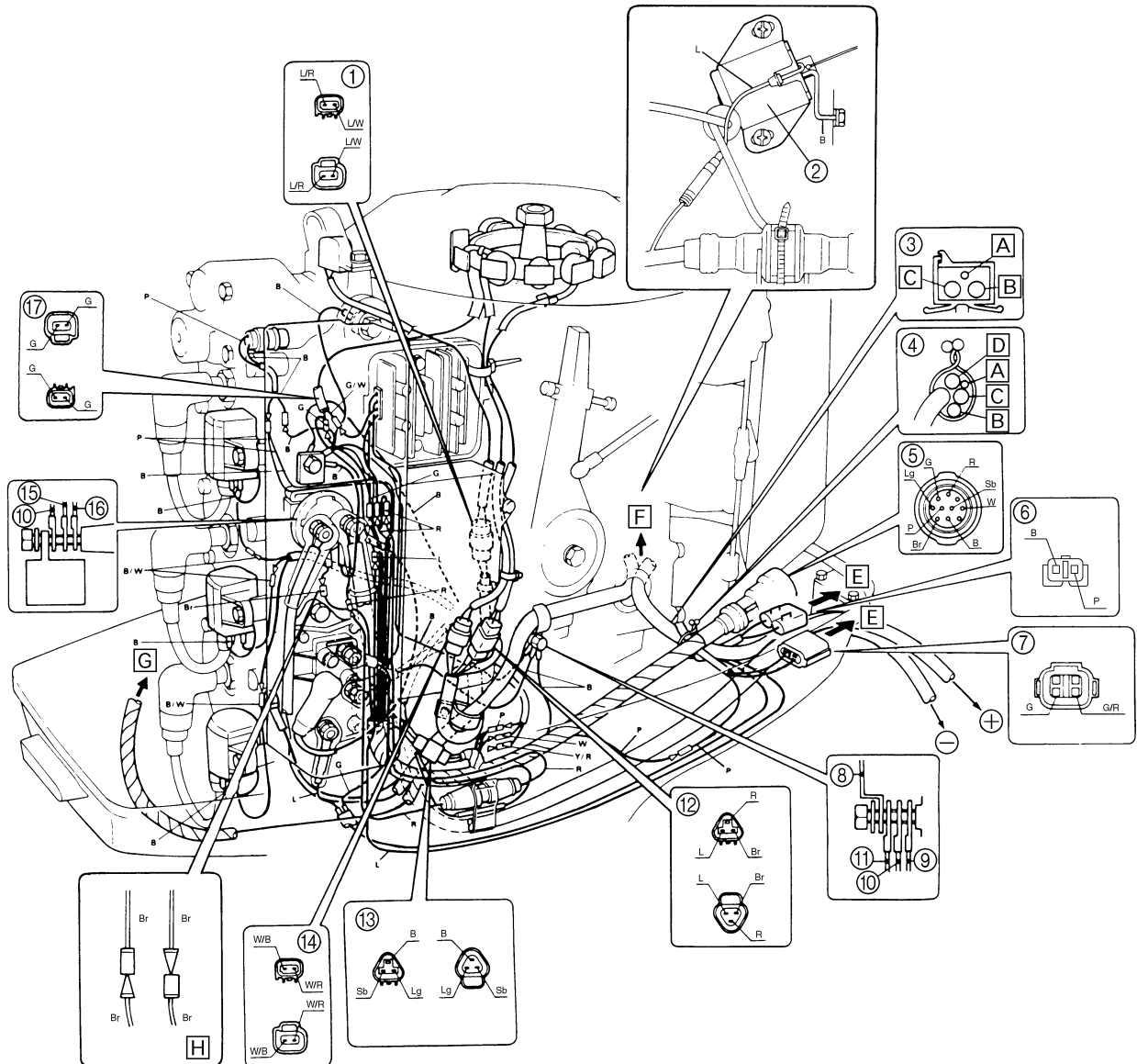

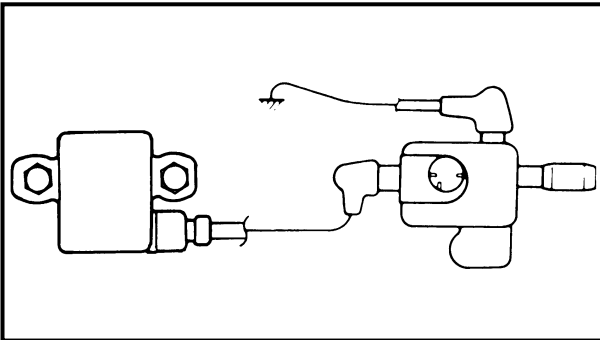
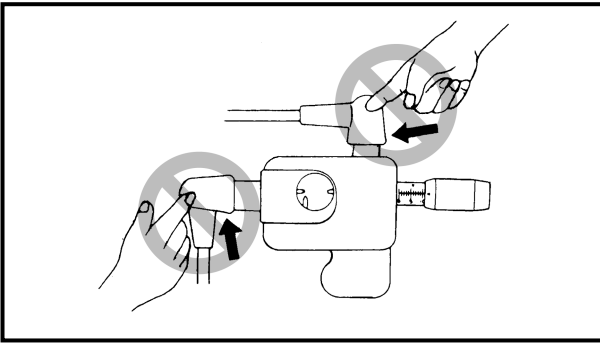
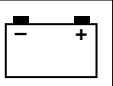

## IGNITION SPARK GAP

### ⚠ WARNING

- While checking the spark be careful not to touch any connection of lead wires of the "Ignition spark gap tester".
- When doing the spark test, take special care not to allow leakage from the plug cap which has been removed.

This check is likely to produce sparks, so be sure that no flammable gas or fluid is present.

#### 1. Ignition spark gap:

- 1) Connect the spark plug cap to the spark gap tester.



**Spark gap tester:**  
YM-34487/90890-06754

- 2) Remove the spark plugs from the engine.
- 3) Crank the engine and check the sparks from the ignition system through the discharge window.
- 4) If the spark is weak, measure the CDI SYSTEM PEAK VOLTAGE.

## CDI SYSTEM PEAK VOLTAGE

### ⚠ WARNING

While taking CDI unit check be careful not to touch any connection of lead wires of the "Digital tester".

#### NOTE:

- If there is no spark or the spark is weak, continue with the CDI test.
- If a good spark is obtained, the problem is not with the CDI system, but possibly the spark plug or other component is defective.

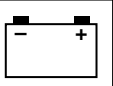

50, 60, 70 hp

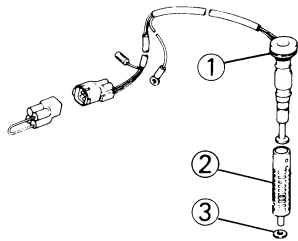

75, 80, 90 hp

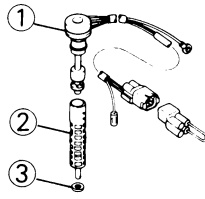

M58004-0

**OIL-LEVEL SENSOR**

1. Remove the circlip and disassemble the oil-level sensor.

- ① Oil-level sensor
- ② Strainer cover
- ③ Gasket

2. Referring to the illustrations and tables, check the continuity and resistance.

**50, 60, 70 hp**

**Marking: 6H3-16**

**Unit: Ω**

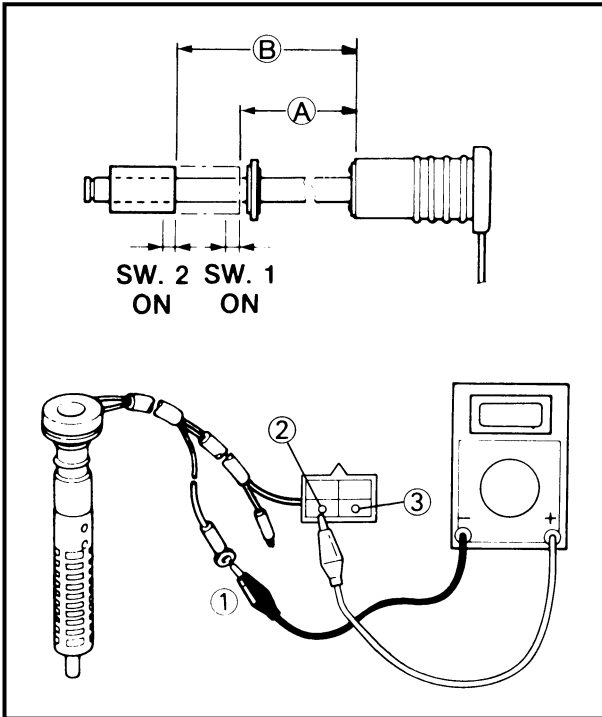

Oil level sensor resistance					
Float SW.1 ON Ⓐ 79.5 ~ 82.5 mm (3.13 ~ 3.25 in)			Float SW. 2 ON Ⓑ 114.5 ~ 117.3 mm (4.51 ~ 4.62 in)		
Tester +	① Black	② Green	Tester +	① Black	③ Green/Red
Tester -	① Black	0	Tester -	① Black	*∞
	② Green	0		③ Green/Red	640

Oil level sensor resistance			
Float SW. 1, SW. 2, both OFF			
Tester +	② Green	② Green	③ Green/Red
Tester -	① Black	∞	*∞
	② Green	∞	∞
	③ Green/Red	*∞	∞

\* "∞" indicates that the pointer deflects once and returns to "∞".

∞ : Discontinuity

CLICK HERE TO **DOWNLOAD** THE COMPLETE MANUAL

- Thank you very much for reading the preview of the manual.
- You can download the complete manual from: [www.heydownloads.com](http://www.heydownloads.com) by clicking the link below



- Please note: If there is no response to CLICKING the link, please download this PDF first and then click on it.

CLICK HERE TO **DOWNLOAD** THE COMPLETE MANUAL