

Edition: August 2006
 Revision: August 2006
 Publication No. SM7E-1V35U0

QUICK REFERENCE INDEX

 **INFINITI**[®]
G35 Coupe
 MODEL V35 SERIES



INFINITI[®]

© 2006 NISSAN MOTOR CO.,LTD.

A GENERAL INFORMATION	GI General Information	
B ENGINE	EM Engine Mechanical	
	LU Engine Lubrication System	
	CO Engine Cooling System	
	EC Engine Control System	
	FL Fuel System	
	EX Exhaust System	
	ACC Accelerator Control System	
	CL Clutch	
C TRANSMISSION/ TRANSAXLE	MT Manual Transmission	
	AT Automatic Transmission	
	PR Propeller Shaft	
D DRIVELINE/AXLE	RFD Rear Final Drive	
	FAX Front Axle	
	RAX Rear Axle	
	FSU Front Suspension	
E SUSPENSION	RSU Rear Suspension	
	WT Road Wheels & Tires	
	BR Brake System	
F BRAKES	PB Parking Brake System	
	BRC Brake Control System	
	PS Power Steering System	
G STEERING	STC Steering Control System	
	SB Seat Belts	
H RESTRAINTS	SRS Supplemental Restraint System (SRS)	
	BL Body, Lock & Security System	
I BODY	GW Glasses, Window System & Mirrors	
	RF Roof	
	EI Exterior & Interior	
	IP Instrument Panel	
	SE Seat	
	ATC Automatic Air Conditioner	
	J AIR CONDITIONER	
K ELECTRICAL	SC Starting & Charging System	
	LT Lighting System	
	DI Driver Information System	
	WW Wiper, Washer & Horn	
	BCS Body Control System	
	LAN LAN System	
	AV Audio Visual, Navigation & Telephone System	
	ACS Auto Cruise Control System	
	PG Power Supply, Ground & Circuit Elements	
	L MAINTENANCE	MA Maintenance
	M INDEX	IDX Alphabetical Index

A
B
C
D
E
F
G
H
I
J
K
L
M

All rights reserved. No part of this Service Manual may be reproduced or stored in a retrieval system, or transmitted in any form, or by any means, electronic, mechanical, recording or otherwise, without the prior written permission of Nissan Motor Company Ltd., Tokyo, Japan.

CLICK HERE TO **DOWNLOAD** THE COMPLETE MANUAL

- Thank you very much for reading the preview of the manual.
- You can download the complete manual from: www.heydownloads.com by clicking the link below



- Please note: If there is no response to CLICKING the link, please download this PDF first and then click on it.

CLICK HERE TO **DOWNLOAD** THE COMPLETE MANUAL

A/T CONTROL SYSTEM

“M1” Position

- The front brake fastens the front sun gear.
- The forward brake and the forward one-way clutch regulate reverse rotation of the mid sun gear.
- High and low reverse clutch connects the rear sun gear and the mid sun gear.
- The low coast brake fastens the mid sun gear.
- During deceleration, the low coast brake regulates forward rotation of the mid sun gear and the engine brake functions.

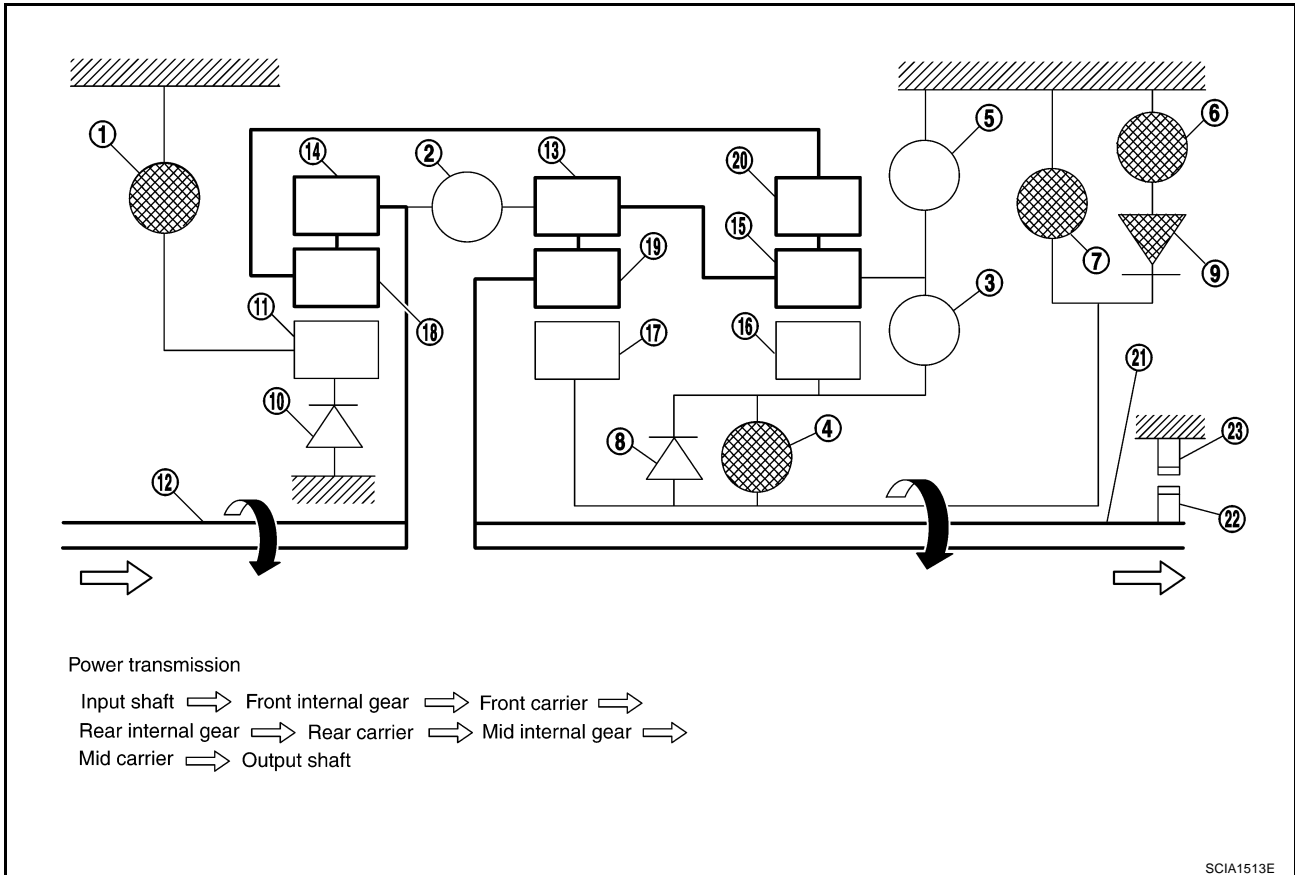

- | | | |
|--------------------------------|-------------------------|---------------------------|
| 1. Front brake | 2. Input clutch | 3. Direct clutch |
| 4. High and low reverse clutch | 5. Reverse brake | 6. Forward brake |
| 7. Low coast brake | 8. 1st one-way clutch | 9. Forward one-way clutch |
| 10. 3rd one-way clutch | 11. Front sun gear | 12. Input shaft |
| 13. Mid internal gear | 14. Front internal gear | 15. Rear carrier |
| 16. Rear sun gear | 17. Mid sun gear | 18. Front carrier |
| 19. Mid carrier | 20. Rear internal gear | 21. Output shaft |
| 22. Parking gear | 23. Parking pawl | |

TROUBLE DIAGNOSIS

ROAD TEST

Description

- The road test inspects overall performance of the A/T and analyzes possible malfunction causes.
- The road test is carried out in the following three stages.
 1. Check before engine is started. Refer to [AT-54](#) .
 2. Check at idle. Refer to [AT-54](#) .
 3. Cruise test
 - Inspect all the items from Part 1 to Part 3. Refer to [AT-56](#) , [AT-58](#) , [AT-59](#) .
- Before beginning the road test, check the test procedure and inspection items.
- Test all inspection items until the symptom is uncovered. Diagnose NG items when all road tests are complete.

Check Before Engine is Started

NCS000BX

1. CHECK A/T CHECK INDICATOR LAMP

1. Park vehicle on level surface.
2. Move selector lever to “P” position.
3. Turn ignition switch OFF and wait at least 10 seconds.
4. Turn ignition switch ON. (Do not start engine.)

Does A/T CHECK indicator lamp light up for about 2 seconds?

YES >> 1. Turn ignition switch OFF.

2. Perform self-diagnostics and record all NG items on the [AT-45, "DIAGNOSTIC WORKSHEET"](#) . Refer to [AT-86, "SELF-DIAGNOSTIC RESULT MODE"](#) , [AT-95, "Diagnostic Procedure Without CONSULT-II"](#) .
3. Go to [AT-54, "Check at Idle"](#) .

NO >> Stop the road test and go to [AT-181, "A/T CHECK Indicator Lamp Does Not Come On"](#) .

Check at Idle

NCS000BY

1. CHECK STARTING THE ENGINE

1. Park vehicle on level surface.
2. Move selector lever to “P” or “N” position.
3. Turn ignition switch OFF.
4. Turn ignition switch to “START” position.

Does the engine start?

YES >> GO TO 2.

NO >> Stop the road test and go to [AT-181, "Engine Cannot Be Started in “P” or “N” Position"](#) .

2. CHECK STARTING THE ENGINE

1. Turn ignition switch ON. (Do not start engine.)
2. Move selector lever to “D”, “M” or “R” position.
3. Turn ignition switch to “START” position.

Does the engine start in either position?

YES >> Stop the road test and go to [AT-181, "Engine Cannot Be Started in “P” or “N” Position"](#) .

NO >> GO TO 3.

TROUBLE DIAGNOSIS

CONSULT-II SETTING PROCEDURE

Refer to [GI-37, "CONSULT-II Start Procedure"](#) .

SELF-DIAGNOSTIC RESULT MODE

After performing self-diagnosis, place check marks for results on the [AT-45, "DIAGNOSTIC WORKSHEET"](#) . Reference pages are provided following the items.

Operation Procedure

1. Touch "SELF-DIAG RESULTS" on "SELECT DIAG MODE" screen.
Display shows malfunction experienced since the last erasing operation.

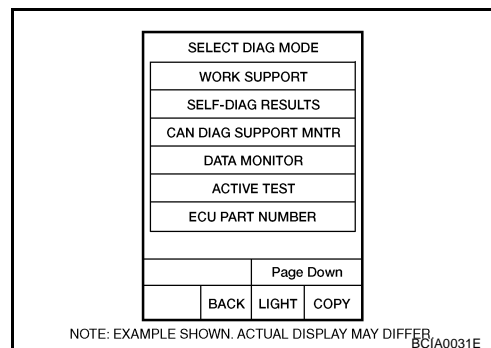

Display Items List

X: Applicable, —: Not applicable

Items (CONSULT-II screen terms)	Malfunction is detected when...	TCM self-diagnosis	OBD-II (DTC)	Reference page
		"A/T" with CONSULT-II	MIL *1 , "ENGINE" with CONSULT-II or GST	
CAN COMM CIR-CUIT	<ul style="list-style-type: none"> ● When TCM is not transmitting or receiving CAN communication signal for 2 seconds or more. 	U1000	U1000	AT-98
STARTER RELAY/CIRC	<ul style="list-style-type: none"> ● If this signal is ON other than in "P" or "N" position, this is judged to be a malfunction. (And if it is OFF in "P" or "N" position, this too is judged to be a malfunction.) 	P0615	—	AT-101
TCM	<ul style="list-style-type: none"> ● TCM is malfunctioning 	P0700	P0700	AT-105
PNP SW/CIRC	<ul style="list-style-type: none"> ● PNP switch 1-4 signals input with impossible pattern ● PNP switch 3 monitor terminal cut line ● P position is detected from "N" position without any other position being detected in between. 	P0705	P0705	AT-106
TURBINE REV S/CIRC	<ul style="list-style-type: none"> ● TCM does not receive the proper voltage signal from the sensor. ● TCM detects an irregularity only at position of 4th gear for turbine revolution sensor 2. 	P0717	P0717	AT-110
VEH SPD SEN/CIR AT	<ul style="list-style-type: none"> ● Signal from vehicle speed sensor A/T (Revolution sensor) not input due to cut line or the like ● Unexpected signal input during running ● After ignition switch is turned ON, unexpected signal input from vehicle speed sensor MTR before the vehicle starts moving 	P0720	P0720	AT-112
ENGINE SPEED SIG	<ul style="list-style-type: none"> ● TCM does not receive the CAN communication signal from the ECM. 	P0725	P0725	AT-117
TCC SOLENOID/CIRC	<ul style="list-style-type: none"> ● Normal voltage not applied to solenoid due to cut line, short, or the like 	P0740	P0740	AT-119
A/T TCC S/V FNCTN	<ul style="list-style-type: none"> ● A/T cannot perform lock-up even if electrical circuit is good. ● TCM detects as irregular by comparing difference value with slip rotation. 	P0744	P0744*2	AT-121

DTC P0725 ENGINE SPEED SIGNAL

NCS000D9

Diagnostic Procedure

1. CHECK CAN COMMUNICATION LINE

Perform self-diagnosis. Refer to [AT-86, "SELF-DIAGNOSTIC RESULT MODE"](#) , [AT-95, "Diagnostic Procedure Without CONSULT-II"](#) .

Is a malfunction in the CAN communication indicated in the results?

- YES >> Check CAN communication line. Refer to [AT-98, "DTC U1000 CAN COMMUNICATION LINE"](#) .
- NO >> GO TO 2.

2. CHECK DTC WITH TCM

With CONSULT-II

1. Start engine.
2. Select "ECU INPUT SIGNALS" in "DATA MONITOR" mode for "A/T" with CONSULT-II.
3. While monitoring engine speed, check for engine speed change corresponding to wide-open throttle position signal.

Item name	Condition	Display value
ENGINE SPEED	Engine running	Closely matches the tachometer reading.

DATA MONITOR			
MONITOR	NO. DTC		
W/O THL POS	OFF		
BRAKE SW	OFF		
ENGINE SPEED	0 rpm		
TURBINE REV	0 rpm		
OUTPUT REV	0 rpm		
▼			
RECORD			
MODE	BACK	LIGHT	COPY

PCIA0041E

OK or NG

- OK >> GO TO 3.
- NG >> Check the ignition signal circuit. Refer to [EC-665, "IGNITION SIGNAL"](#) .

3. CHECK DTC

Perform [AT-117, "DTC Confirmation Procedure"](#) .

OK or NG

- OK >> **INSPECTION END**
- NG >> GO TO 4.

4. CHECK TCM POWER SUPPLY AND GROUND CIRCUIT

Check TCM power supply and ground circuit. Refer to [AT-172, "MAIN POWER SUPPLY AND GROUND CIRCUIT"](#) .

OK or NG

- OK >> GO TO 5.
- NG >> Repair or replace damaged parts.

5. DETECT MALFUNCTIONING ITEM

Check A/T assembly harness connector pin terminals for damage or loose connection with harness connector.

OK or NG

- OK >> Replace control valve with TCM. Refer to [AT-225, "Control Valve with TCM and A/T Fluid Temperature Sensor 2"](#) .
- NG >> Repair or replace damaged parts.

DTC P1764 DIRECT CLUTCH SOLENOID VALVE FUNCTION

DTC P1764 DIRECT CLUTCH SOLENOID VALVE FUNCTION

PF3:31940

Description

NCS000FY

- Direct clutch solenoid valve is controlled by the TCM in response to signals sent from the PNP switch, vehicle speed sensor and accelerator pedal position sensor (throttle position sensor). Gears will then be shifted to the optimum position.
- This is not only caused by electrical malfunction (circuits open or shorted) but also by mechanical malfunction such as control valve sticking, improper solenoid valve operation.

CONSULT-II Reference Value

NCS000FZ

Item name	Condition	Display value (Approx.)
D/C SOLENOID	Direct clutch disengaged. Refer to AT-19 .	0.6 - 0.8 A
	Direct clutch engaged. Refer to AT-19 .	0 - 0.05 A
ATF PRES SW 5	Direct clutch engaged. Refer to AT-19 .	ON
	Direct clutch disengaged. Refer to AT-19 .	OFF

On Board Diagnosis Logic

NCS000G0

- This is an OBD-II self-diagnostic item.
- Diagnostic trouble code “P1764 D/C SOLENOID FNCTN” with CONSULT-II or 2nd judgment flicker without CONSULT-II is detected under the following conditions.
 - When TCM detects that actual gear ratio is irregular, and relation between gear position and condition of ATF pressure switch 5 is irregular during depressing accelerator pedal. (Other than during shift change)
 - When TCM detects that relation between gear position and condition of ATF pressure switch 5 is irregular during releasing accelerator pedal. (Other than during shift change)

Possible Cause

NCS000G1

- Harness or connectors.
(Solenoid and switch circuits are open or shorted.)
- Direct clutch solenoid valve.
- ATF pressure switch 5.

DTC Confirmation Procedure

NCS000G2

CAUTION:

Always drive vehicle at a safe speed.

NOTE:

If “DTC Confirmation Procedure” has been previously performed, always turn ignition switch OFF and wait at least 10 seconds before performing the next test.

After the repair, perform the following procedure to confirm the malfunction is eliminated.

WITH CONSULT-II

1. Start engine.
2. Accelerate vehicle to maintain the following conditions.
ACCELE POSI: 1.5/8 - 2.0/8
SLCT LVR POSI: “D” position
GEAR: “1” ⇒ “2” (D/C ON/OFF)
Driving location: Driving the vehicle uphill (increased engine load) will help maintain the driving conditions required for this test.
3. Perform step “2” again.
4. Turn ignition switch OFF, then perform step “1” to “3” again.
5. Check “SELF-DIAG RESULTS” mode for “A/T” with CONSULT-II. If DTC (P1764) is detected, refer to [AT-151, "Diagnostic Procedure"](#) .
If DTC (P1762) is detected, go to [AT-149, "Diagnostic Procedure"](#) .
If DTC (P1845) is detected, go to [AT-169, "Diagnostic Procedure"](#) .

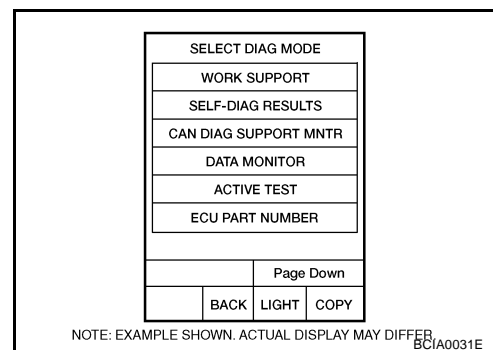

TROUBLE DIAGNOSIS FOR SYMPTOMS

2. CHECK A/T POSITION

Check A/T position. Refer to [AT-216, "Checking of A/T Position"](#) .

OK or NG

OK >> GO TO 3.

NG >> Adjust A/T position. Refer to [AT-215, "Adjustment of A/T Position"](#) .

3. CHECK STARTING SYSTEM

Check starting system. Refer to [SC-10, "STARTING SYSTEM"](#) .

OK or NG

OK >> **INSPECTION END**

NG >> Repair or replace damaged parts.

In "P" Position, Vehicle Moves When Pushed SYMPTOM:

NCS00010

Even though the selector lever is set in the "P" position, the parking mechanism is not actuated, allowing the vehicle to be moved when it is pushed.

DIAGNOSTIC PROCEDURE

1. CHECK A/T POSITION

Check A/T position. Refer to [AT-216, "Checking of A/T Position"](#) .

OK or NG

OK >> GO TO 2.

NG >> Adjust A/T position. Refer to [AT-215, "Adjustment of A/T Position"](#) .

2. CHECK PARKING COMPONENTS

Check parking components. Refer to [AT-236, "Parking Components"](#) .

OK or NG

OK >> **INSPECTION END**

NG >> Repair or replace damaged parts.

SHIFT CONTROL SYSTEM

REMOVAL

1. Disconnect lower lever of control device and control rod.
2. Remove knob cover below selector lever downward.
3. Pull lock pin out of selector lever knob.
4. Remove selector lever knob.
5. Remove console finisher. Refer to [IP-11, "Removal and Installation"](#).
6. Remove center console. Refer to [IP-11, "Removal and Installation"](#).
7. Remove key interlock cable from control device. Refer to [AT-223, "Removal and Installation"](#).
8. Disconnect A/T device harness connector.
9. Remove control device assembly.

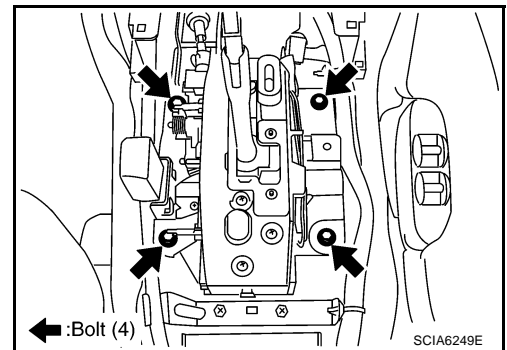
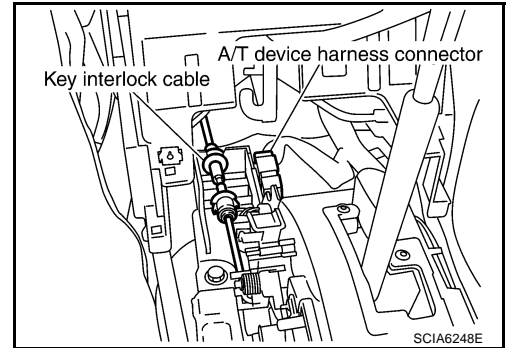
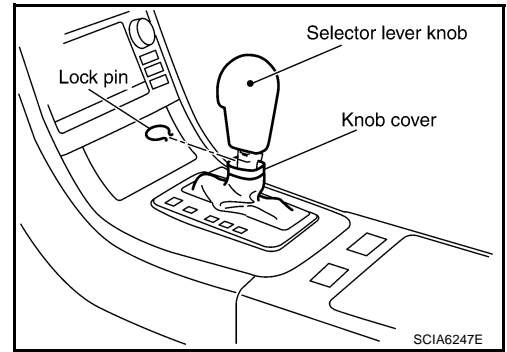

INSTALLATION

Note the following, and install in the reverse order of removal.

- After installation is completed, adjust and check A/T position. Refer to [AT-215, "Adjustment of A/T Position"](#) and [AT-216, "Checking of A/T Position"](#).

ON-VEHICLE SERVICE

12. Tap rear extension assembly with a soft hammer.

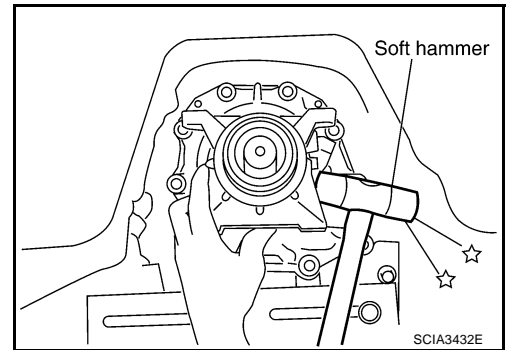

13. Remove rear extension assembly from transmission case. (With needle bearing.)

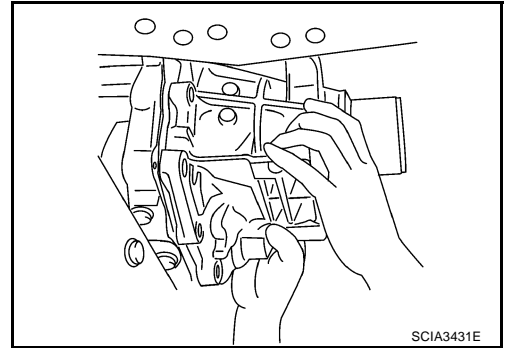

14. Disconnect revolution sensor connector.

CAUTION:
Be careful not to damage connector.

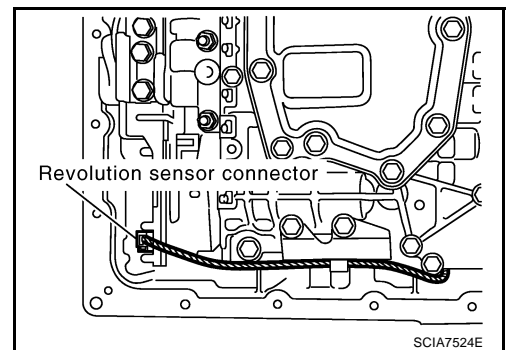

15. Straighten terminal clip to free revolution sensor harness.

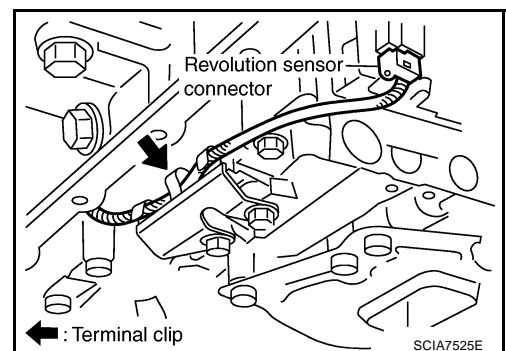

16. Remove revolution sensor from transmission case.

CAUTION:

- Do not subject it to impact by dropping or hitting it.
- Do not disassemble.
- Do not allow metal filings, etc. to get on the sensor's front edge magnetic area.
- Do not place in an area affected by magnetism.

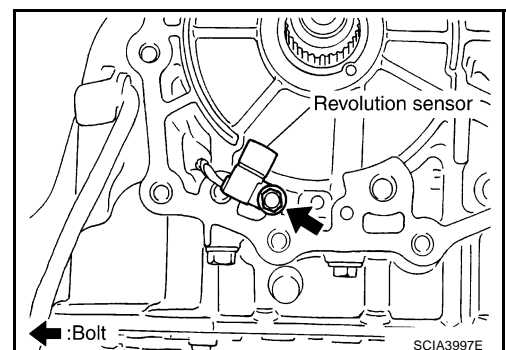

DISASSEMBLY

76. Remove parking actuator support from rear extension.

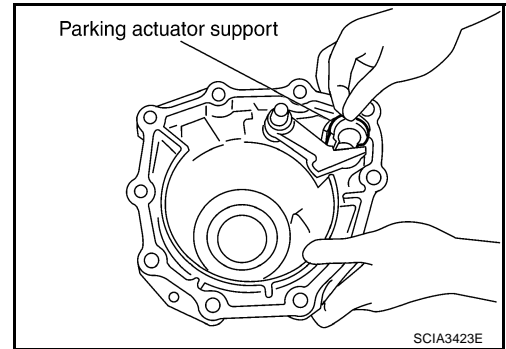

77. Remove parking pawl (with return spring) and pawl shaft from rear extension.

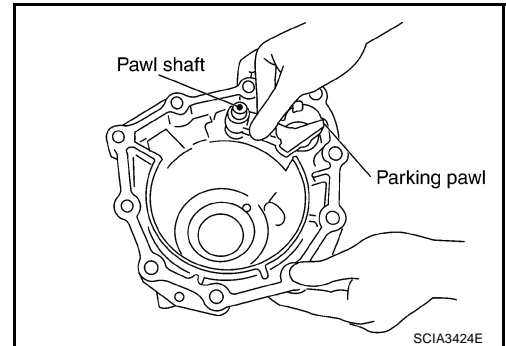

78. Remove return spring (1) from parking pawl (2).

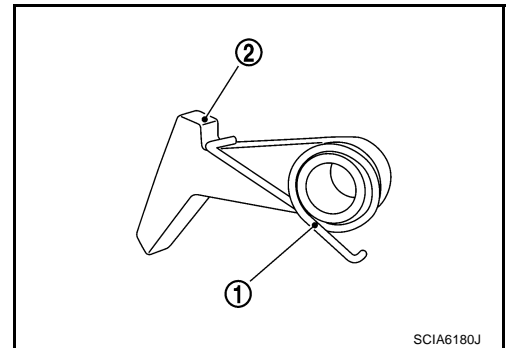

79. Remove rear oil seal from rear extension.

CAUTION:
Be careful not to scratch rear extension.

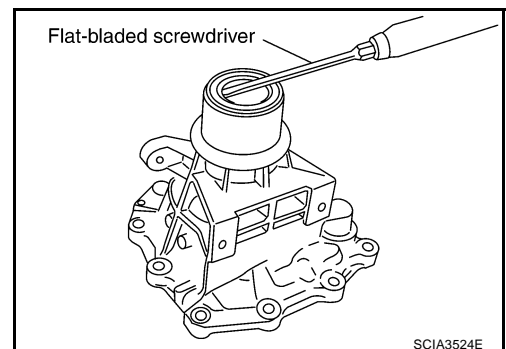

ASSEMBLY

55. Adjust brake band.

- a. Loosen lock nut.
- b. Tighten band servo anchor end pin to the specified torque.

 : 5.0 N·m (0.51 kg·m, 44 in·lb)

- c. Back of band servo anchor end pin three turns.
- d. Holding band servo anchor end pin, and then tighten lock nut to the specified torque. Refer to [AT-255, "Components"](#) .

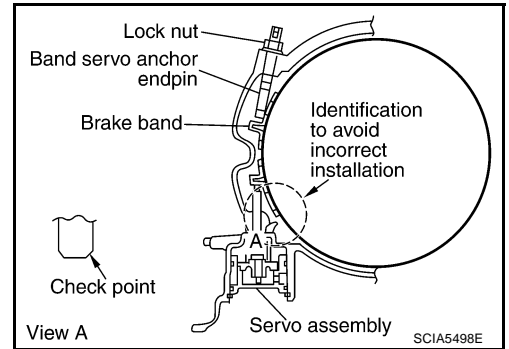

NCS000JC

Adjustment TOTAL END PLAY

- Measure clearance between front sun gear and bearing race for oil pump cover.
- Select proper thickness of bearing race so that end play is within specifications.

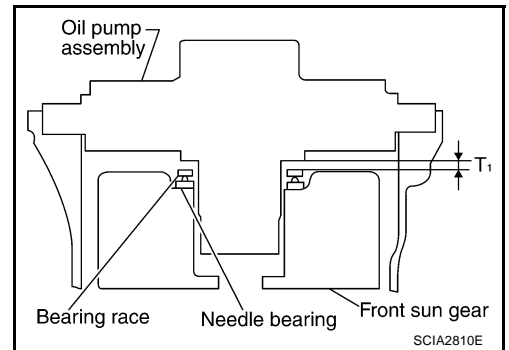

1. Measure dimensions "K" and "L" and then calculate dimension "J".

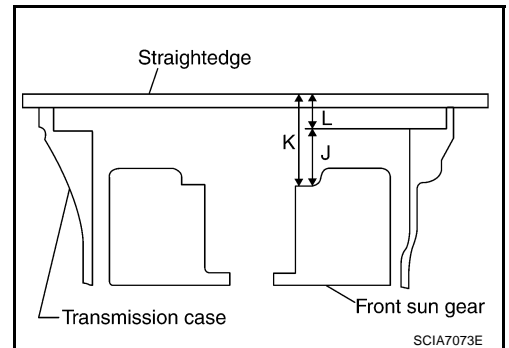

- a. Measure dimension "K".

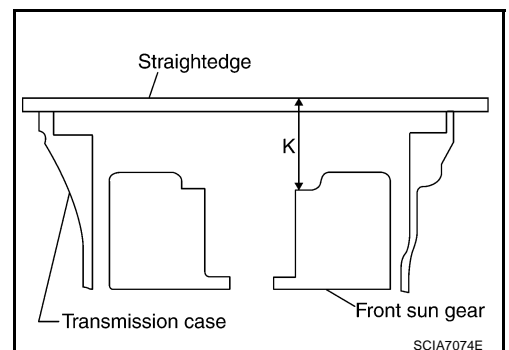

REFRIGERATION SYSTEM

Operation

1. Control Valve

- By changing high-pressure valve lift amount, built-in electronic control valve executes the following:
 - Controls high-pressure valve discharge amount.
 - Changes crankcase pressure in compressor.
 - Changes angle of wobble (swash) plate.
- Amount of high-pressure valve lift is determined by factors below.
 - Low-pressure applied to diaphragm
 - Spring load of set spring
 - Balance of magnetic force generated by magnet coil
- Electronic control valve (ECV) magnet coil receives electric signal (duty control) from display and A/C auto amp. Then, magnetic force generated by electric current is changed to control high-pressure valve lift amount.

2. Maximum Cooling

High-pressure valve is closed by magnetic force generated by electric signal sent from display and A/C auto amp. At this time, cylinder moves full stroke due to pressure balance between inside crankcase (P_c) and suction line (P_s).

Under this condition, the wobble (swash) plate is set to the maximum stroke position.

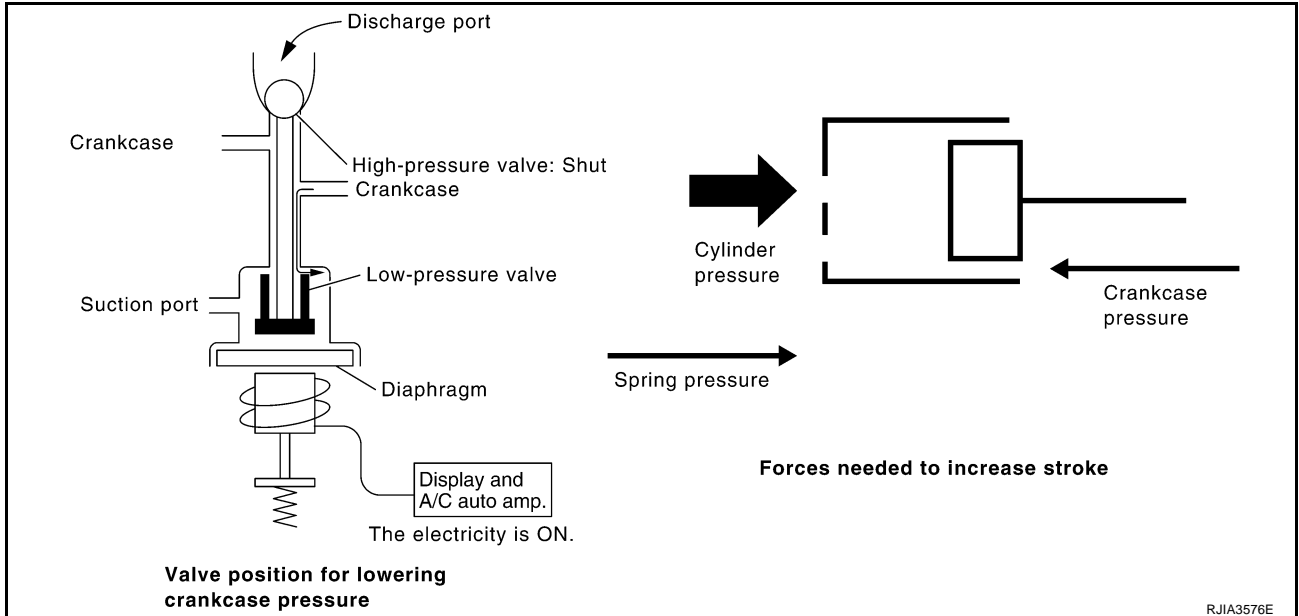

3. Capacity Control

When no electric signal is sent from display and A/C auto amp. (current: OFF), high-pressure valve is opened by spring force.





Since suction pressure is low, it makes the suction port close and the discharge port open. Thus, crankcase pressure becomes high as high-pressure enters the crankcase.

- The force acts around the journal pin near the wobble (swash) plate, and is generated by the pressure difference before and behind the piston.
- The drive lug and journal pin are located where the piston generates the highest pressure. Piston pressure is between suction pressure P_s and discharge pressure P_d , which is close to suction pressure P_s . If crankcase pressure P_c rises due to capacity control, the force around the journal pin makes the wobble (swash) plate angle decrease and also the piston stroke decrease. In other words, crankcase pressure

TROUBLE DIAGNOSIS

8. CHECK ACTUATORS

Refer to the following chart and check discharge air flow, air temperature, blower motor duty ratio and compressor operation.

Discharge air flow			
Mode door position	Air outlet/distribution		
	Vent	Foot	Defroster
	100%	–	–
	58%	42%	–
	19% (25%)	61% (75%)	20% (–)
	16%	54%	30%
	–	–	100%

() : Manually control SJIA0565E

Code No.	41	42	43	44	45	46
Mode door position	VENT	B/L 1	B/L 2	FOOT*1	D/F	DEF
Intake door position	REC	REC	20%FRE	FRE	FRE	FRE
Air mix door position	FULL COLD	FULL COLD	FULL HOT	FULL HOT	FULL HOT	FULL HOT
Blower motor duty ratio	37%	91%	65%	65%	65%	91%
Compressor	ON	ON	OFF	OFF	ON	ON
Electronic control valve (ECV) duty ratio	100%	100%	0%	0%	50%	100%

Checks must be made visually, by listening the sound, or by touching air outlets with hand, etc. for improper operation.

*1: FOOT position during automatic control. Refer to [ATC-59, "AUXILIARY MECHANISM: FOOT POSITION SETTING TRIMMER"](#) .

OK or NG

OK >> GO TO 9.

- NG >> ● Air outlet does not change.
Go to Mode Door Motor Circuit. Refer to [ATC-68, "Mode Door Motor Circuit"](#) .
- Intake door does not change.
Go to Intake Door Motor Circuit. Refer to [ATC-74, "Intake Door Motor Circuit"](#) .
 - Discharge air temperature does not change.
Go to Air Mix Door Motor Circuit. Refer to [ATC-71, "Air Mix Door Motor Circuit"](#) .
 - Blower motor operation is malfunctioning.
Go to Blower Motor Circuit. Refer to [ATC-77, "Blower Motor Circuit"](#) .
 - Magnet clutch does not engage.
Go to Magnet Clutch Circuit. Refer to [ATC-82, "Magnet Clutch Circuit"](#) .

9. STEP-5: TEMPERATURE OF EACH SENSOR IS CHECKED

1. Turn temperature control dial clockwise.
2. Code No. 51 appears on the display.

>> GO TO 10.

TROUBLE DIAGNOSIS

8. CHECK REFRIGERANT PRESSURE SENSOR

Ⓟ WITH CONSULT-II

1. Start the engine.
2. Check the voltage of refrigerant pressure sensor. Refer to [EC-135, "CONSULT-II Reference Value in Data Monitor"](#).

ⓧ WITHOUT CONSULT-II

1. Start the engine.
2. Check voltage between ECM harness connector F108 terminal 70 and ground.

Terminals		(-)	Condition	Voltage
(+) ECM connector				
ECM connector	Terminal No.			
F108	70	Ground	A/C switch: ON (Blower motor operates.)	Approx. 1.0 - 4.0 V

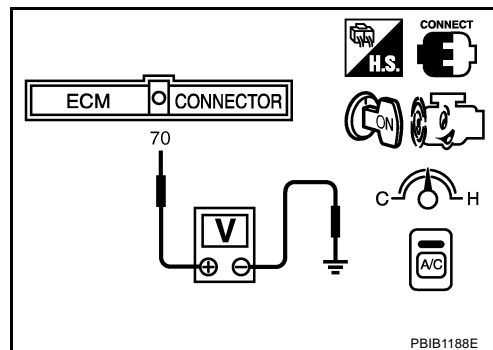

OK or NG

- OK >> ● Ⓟ WITH CONSULT-II: GO TO 9.
 ● ⓧ WITHOUT CONSULT-II: GO TO 10.
 NG >> Refer to [EC-678, "REFRIGERANT PRESSURE SENSOR"](#).

9. CHECK BCM INPUT (FAN ON) SIGNAL

Check FAN ON/OFF signal. Refer to [ATC-38, "CONSULT-II Function \(BCM\)"](#).

FAN SW ON : FAN ON SIG ON
FAN SW OFF : FAN ON SIG OFF

OK or NG

- OK >> GO TO 12.
 NG >> GO TO 10.

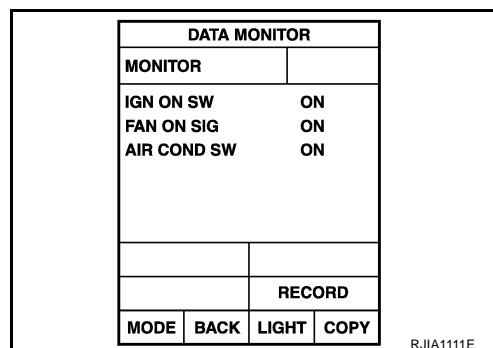

10. CHECK CIRCUIT CONTINUITY BETWEEN BCM AND DISPLAY AND A/C AUTO AMP.

1. Turn ignition switch OFF.
2. Disconnect BCM connector and display and A/C auto amp. connector.
3. Check continuity between BCM harness connector M1 terminal 28 and display and A/C auto amp. harness connector M31 terminal 9.

28 - 9 : Continuity should exist.

OK or NG

- OK >> GO TO 11.
 NG >> Repair harness or connector.

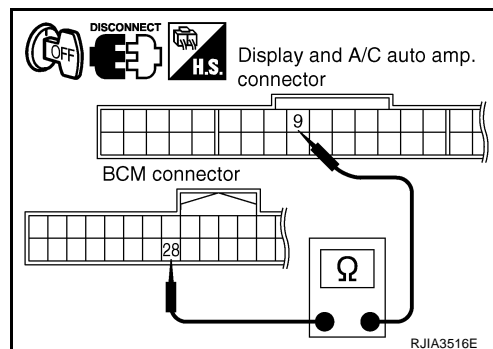

INTAKE SENSOR

INTAKE SENSOR

PFP:27723

Removal and Installation

NJS00040

REMOVAL

1. Remove low-pressure pipe 2 and high-pressure pipe 2. Refer to [ATC-144, "Removal and Installation of Low-pressure Pipe 2 and High-pressure Pipe 2"](#).

CAUTION:

Cap or wrap the joint of evaporator, low-pressure pipe 1 and high-pressure pipe 2 with suitable material such as vinyl tape to avoid the entry of air.

2. Slide evaporator to passenger side, and then remove intake sensor.

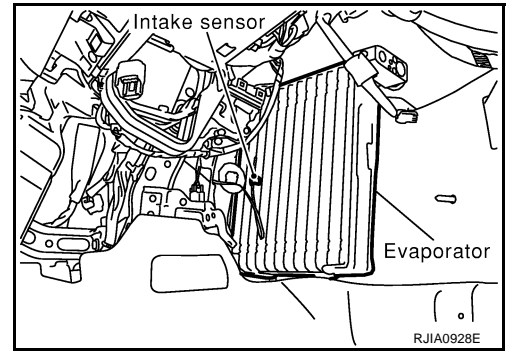

INSTALLATION

Installation is basically the reverse order of removal.

CAUTION:

- Replace O-rings of low-pressure pipe 1, 2 and high-pressure pipe 1, 2 with new ones, and then apply compressor oil to it when installing it.
- Mark the mounting position of intake sensor bracket prior to removal so that the reinstalled sensor can be located in the same position.
- Female-side piping connection is thin and easy to deform. Slowly insert the male-side piping straight in axial direction.
- Insert piping securely until a click is heard.
- After piping connection is completed, pull male-side piping by hand to make sure that connection does not come loose.
- When recharging refrigerant, check for leaks.

REFRIGERANT LINES

Removal and Installation of Expansion Valve

NJS0004P

REMOVAL

1. Remove evaporator. Refer to [ATC-149, "Removal and Installation of Evaporator"](#) .
2. Remove mounting bolts, and then remove expansion valve.

CAUTION:

Cap or wrap the joint of evaporator with suitable material such as vinyl tape to avoid the entry of air.

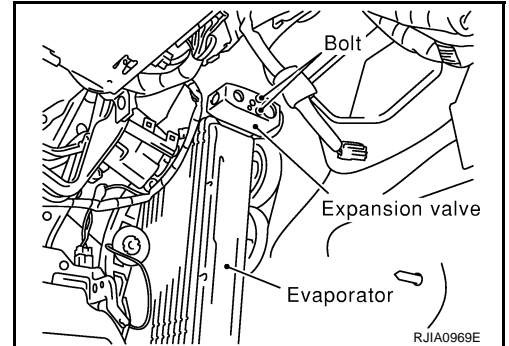

INSTALLATION

Installation is basically the reverse order of removal.

CAUTION:

- Replace O-rings of evaporator with new ones, and then apply compressor oil to it when installing it.
- O-rings are different from low-pressure pipe 1 (high-pressure pipe 1) and low-pressure pipe 2 (high-pressure pipe 2).
- When recharging refrigerant, check for leaks.

AUDIO

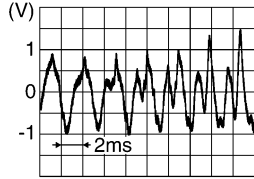
Terminal (Wire color)		Item	Signal input/out- put	Condition		Reference value
+	-			Ignition switch	Operation	
30 (W)	29 (OR)	Audio signal front LH	Input	ON	Receive audio sig- nal	 <small>SKIB3609E</small>
31 (SB)	Ground	Amp. ON signal	Input	ON	—	Approx. 12 V

Steering Wheel Audio Control Switch Resistance Inspection

NKS002F7

Terminal	Signal name	Condition	Resistance (Ω)	
16	17	Power	Depress power switch*1 .	Approx. 0
		Seek down (previous)	Depress (station) down switch.	Approx. 165
		Volume (down)	Depress volume down switch.	Approx. 652
20	17	Mode	Depress mode switch*2 .	Approx. 0
		Seek up (next)	Depress (station) up switch.	Approx. 165
		Volume (up)	Depress volume up switch.	Approx. 652

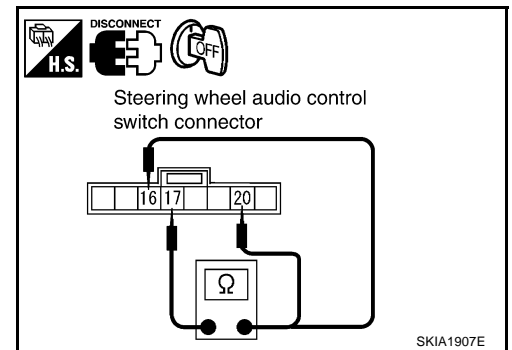

*1 With telephone system: MODE switch

*2 With telephone system: PTT switch

NAVIGATION SYSTEM

NKS002FY

Self-Diagnosis Function DESCRIPTION

- Diagnosis function consists of the self-diagnosis mode performed automatically and the CONFIRMATION/ADJUSTMENT mode operated manually.
- Self-diagnosis mode checks for connections between the units constituting this system, analyzes each individual unit at the same time, and displays the results on the LCD screen.
- CONFIRMATION/ADJUSTMENT mode is used to perform trouble diagnoses that require operation and judgment by an operator (malfunction that cannot be automatically judged by the system), to check/change the set value, and to display the History of Errors of the navigation system.

DIAGNOSIS ITEM

Mode		Description	
Self Diagnosis		<ul style="list-style-type: none"> ● NAVI control unit diagnosis and connection diagnosis between NAVI control unit and each unit ● The DVD-ROM drive diagnosis of NAVI control unit and the connection diagnosis between NAVI control unit and GPS antenna can be performed (DVD-ROM drive will not be diagnosed when no map DVD-ROM is in it.) 	
Confirmation/ Adjustment	Display Diagnosis	The tint can be confirmed by the color spectrum bar display. The shading of color can be confirmed by the gradation bar display.	
	Vehicle Signals	Diagnosis of signals can be performed for vehicle speed, lights, ignition switch, and reverse.	
	Navigation	Steering Angle Adjustment	When there is a difference between the actual turning angle and the vehicle mark turning angle, it can be adjusted.
		Speed Calibration	When there is a difference between the current-location mark and the actual location, it can be adjusted.
	Error History	The system malfunction and the frequency when occurred in the past are displayed. When the malfunctioning item is selected, the time and place that the selected malfunction last occurred are displayed.	
Delete Unit Connection Log		Erase the connection history of unit and error history	

NAVIGATION SYSTEM

Removal and Installation of NAVI Control Unit

NKS002G0

REMOVAL

1. Remove center box assembly. Refer to [IP-10, "INSTRUMENT PANEL ASSEMBLY"](#) .
2. Remove screws (4), and remove NAVI control unit.

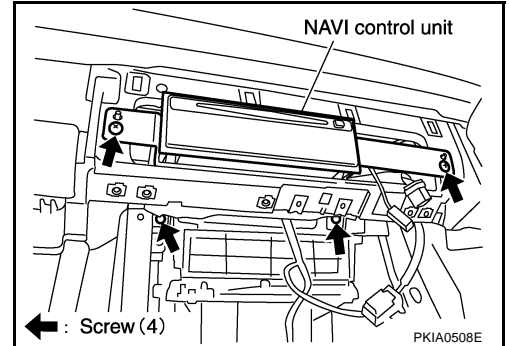

3. Remove screws (4), and remove bracket.

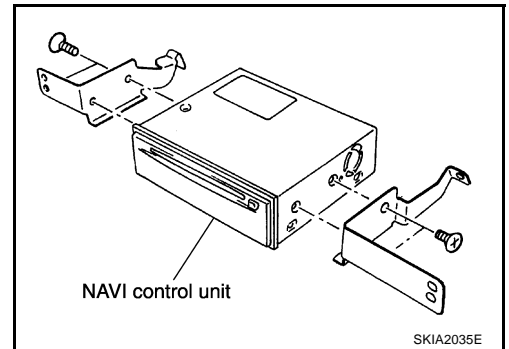

INSTALLATION

Installation is the reverse order of removal.

Removal and Installation of GPS Antenna

NKS002GP

REMOVAL

1. Remove instrument panel and antenna feeder installation screws on backside. Refer to [IP-10, "INSTRUMENT PANEL ASSEMBLY"](#) .

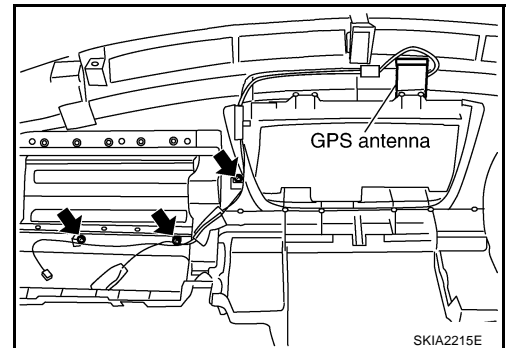

2. Remove screw and remove GPS antenna.

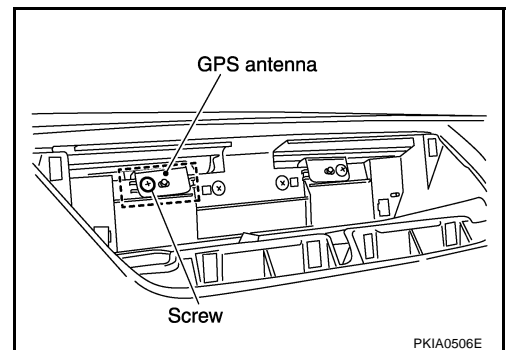

INSTALLATION

Installation is the reverse order of removal.

BCM (BODY CONTROL MODULE)

System	Input	Output
Rear window defogger	<ul style="list-style-type: none">● Rear window defogger switch● Ignition switch	IPDM E/R
<ul style="list-style-type: none">● A/C switch signal● Blower fan switch signal	Display and A/C auto amp.	ECM
Low tire pressure warning system	Remote keyless entry receiver	Combination meter

CAN Communication Unit

NKS000N0

Refer to [LAN-47, "CAN System Specification Chart"](#) .

POWER DOOR LOCK SYSTEM

BL-D/LOCK-02

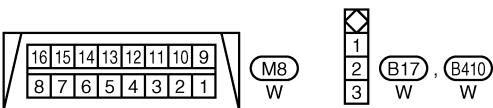
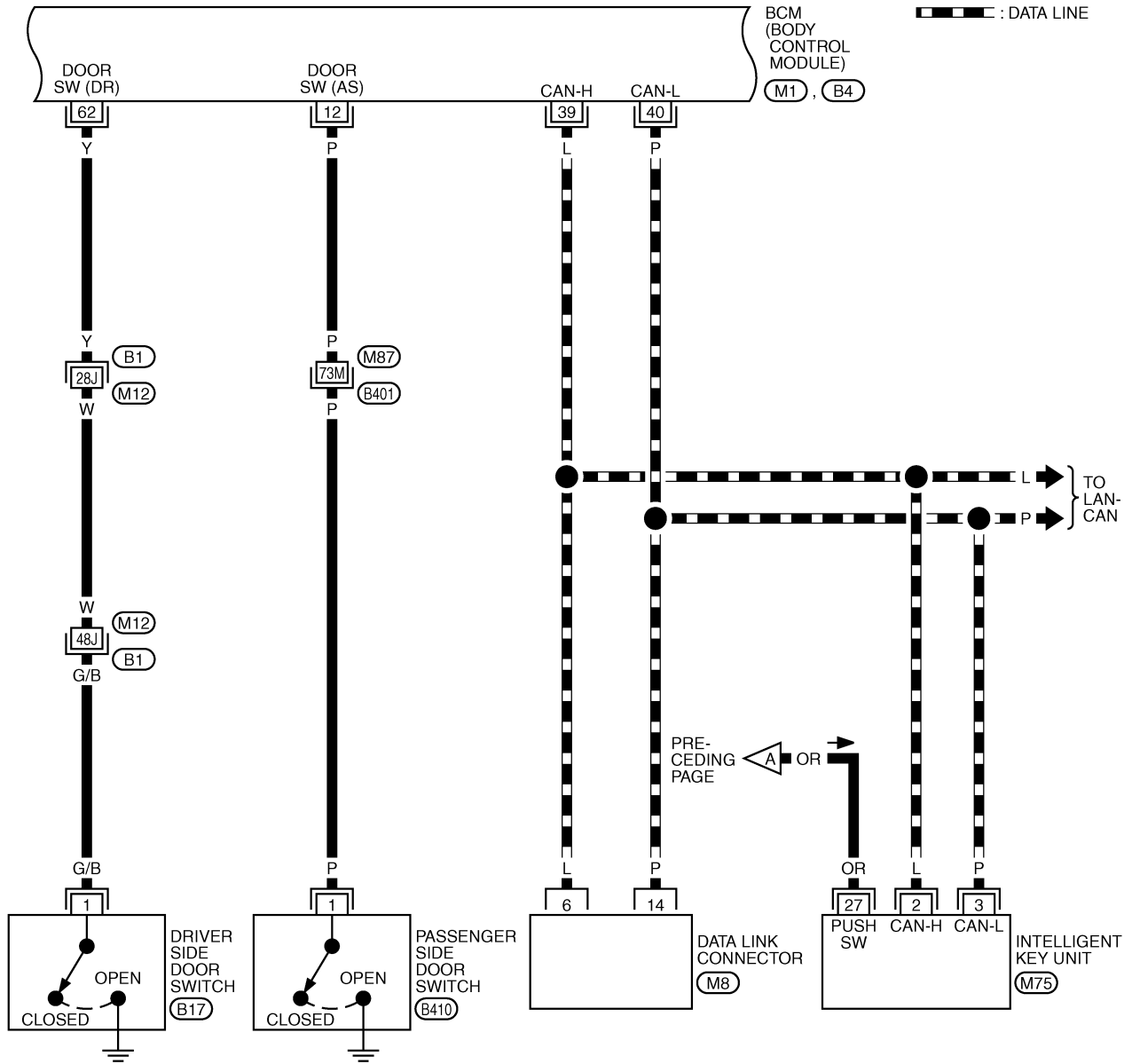

REFER TO THE FOLLOWING.
 (B1), (B401) -SUPER MULTIPLE JUNCTION (SMJ)
 (M1), (M75), (B4) -ELECTRICAL UNITS

TIWM1460E

REMOTE KEYLESS ENTRY SYSTEM

BL-KEYLES-04

▬ : DATA LINE

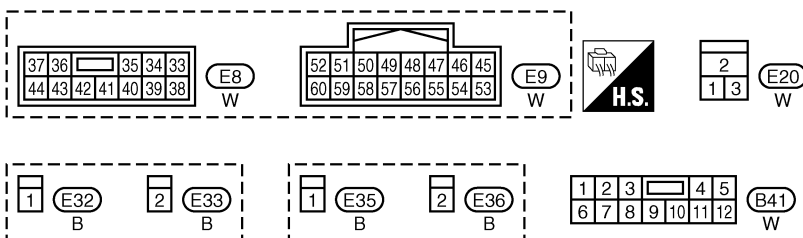
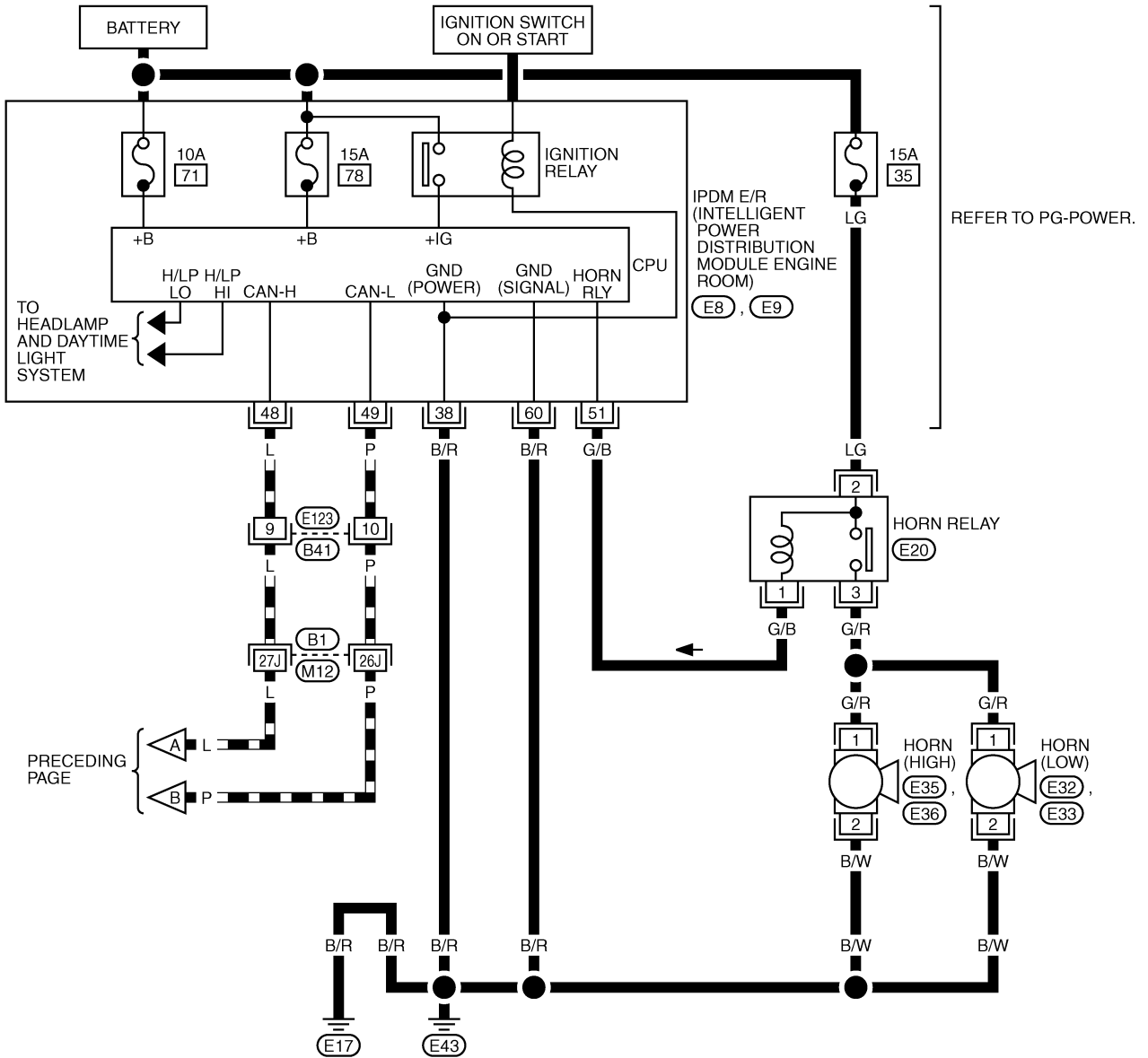

REFER TO THE FOLLOWING.

(B1) -SUPER MULTIPLE JUNCTION (SMJ)

TIWM1468E

INTELLIGENT KEY SYSTEM

ENGINE START FUNCTION

When the registered Intelligent Key is carried, the engine can be started without inserting the key.

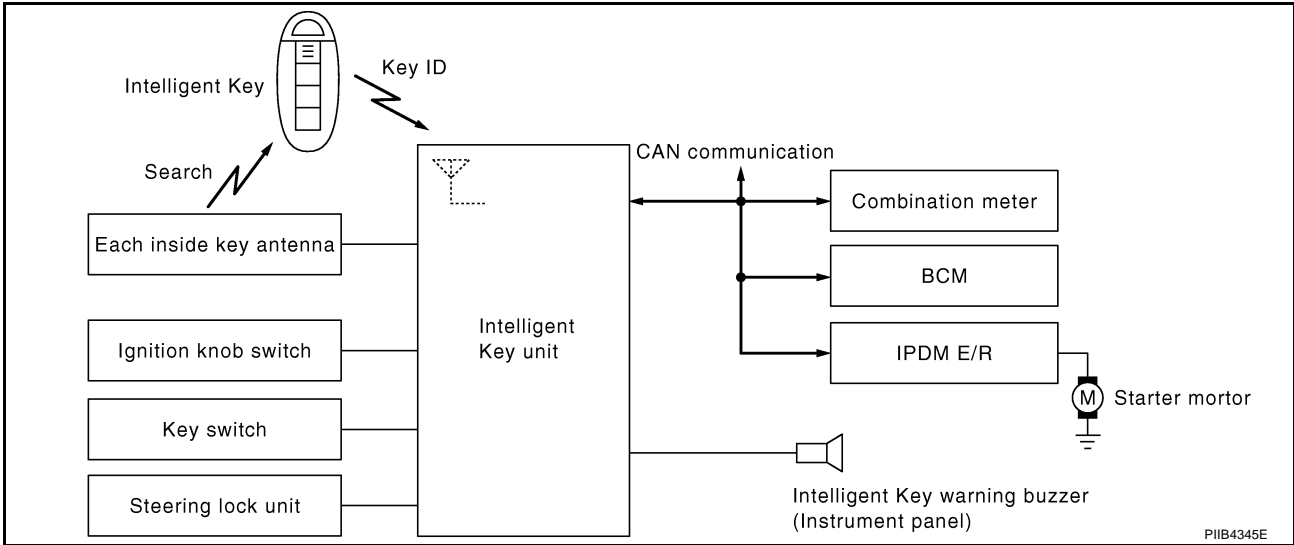

When ignition knob switch is ON (press ignition switch), Intelligent Key unit searches Intelligent Key in the vehicle using inside key antenna.

When Intelligent Key is inside the vehicle, it performs the following operation.

- Illuminate green “KEY” warning lamp in combination meter.
- Released steering lock and ignition switch can be turned from OFF to ACC, ON or START position.

NOTE:

If Intelligent Key is not registered, “KEY” warning lamp in combination meter illuminates red.

- Intelligent Key sends engine start signal via CAN communication line.

When ignition switch turns to START position, BCM sends starter request signal to IPDM E/R. Then, engine starts.

Even if Intelligent Key battery runs down, Intelligent key unit can start engine with mechanical key built Intelligent Key. For details, refer to [BL-214, "IVIS \(INFINITI VEHICLE IMMOBILIZER SYSTEM-NATS\)"](#).

All of the originally supplied Intelligent Key IDs (except for key) have been registered in Intelligent Key system. If requested by the vehicle owner, a maximum of four Intelligent Key IDs can be registered into the Intelligent Key system components.

List of Operation Related Parts

Parts marked with × are the parts related to operation.

Engine start functions	Intelligent Key	Key switch	Ignition knob switch	Inside key antenna	Intelligent Key unit	CAN communication system	BCM	Combination meter	IPDM E/R	NATS antenna amp.	Steering lock unit
Engine start function by the Intelligent Key	×	×	×	×	×	×	×	×	×		×
Engine start function by the mechanical key		×			×	×	×		×	×	×

INTELLIGENT KEY SYSTEM

TRUNK OPEN FUNCTION MALFUNCTION

NOTE:

- Before performing the diagnosis in the following table, check “Trouble Diagnosis Procedure”. Refer to [BL-112, "Trouble Diagnosis Procedure"](#) .
- Make sure that vehicle is under the condition shown in “Conditions of vehicle” before starting diagnosis, and check each symptom.
- If the following “symptoms” are detected, check systems shown in the “Diagnosis/service procedure” column in this order.

Conditions of Vehicle (Operating Conditions)

- “LOCK/UNLOCK BY I-KEY” is ON when setting on CONSULT-II.
- Trunk cancel switch is in ON position.

Symptom	Diagnosis procedure	Reference page
Trunk open function does not operate by trunk opener request switch.	1. Check trunk opener request switch.	BL-138
	2. Check outside key antenna (rear bumper).	BL-143
	3. Replace Intelligent Key unit.	BL-157

HAZARD AND HORN REMINDER FUNCTION MALFUNCTION

NOTE:

- Before performing the diagnosis in the following table, check “Trouble Diagnosis Procedure”. Refer to [BL-112, "Trouble Diagnosis Procedure"](#) .
- Make sure that vehicle is under the condition shown in “Conditions of vehicle” before starting diagnosis, and check each symptom.
- If the following “symptoms” are detected, check systems shown in the “Diagnosis/service procedure” column in this order.

Conditions of Vehicle (Operating Conditions)

- Ignition switch is not depressed.
- All doors are closed.

Symptom	Diagnosis/service procedure	Reference page
Hazard reminder does not operate properly by request switch. (Horn reminder operate properly.)	1. Check “HAZARD ANSWER BACK” setting in “WORK SUPPORT”.	BL-115
	2. Check hazard function with hazard switch.	LT-77
	3. Replace Intelligent Key unit	BL-157
Horn reminder does not operate properly by request switch. (Hazard reminder operate properly.)	1. Check “ANSWER BACK WITH I-KEY LOCK” or “ANSWER BACK WITH I-KEY UNLOCK” setting in “WORK SUPPORT”.	BL-115
	2. Check Intelligent Key warning buzzer (engine room).	BL-142
	3. Check horn function.	BL-156
	4. Check IPDM E/R operation.	BL-156
	5. Replace Intelligent Key unit	BL-157
Hazard reminder does not operate properly by Intelligent Key remote control button. (Horn reminder operate properly.)	1. Check “HAZARD ANSWER BACK” setting in “WORK SUPPORT”.	BL-115
	2. Check hazard function.	BL-156
	3. Replace Intelligent Key	BL-157
Horn reminder does not operate properly by Intelligent Key remote control button (door lock/unlock button). (Hazard reminder operate properly.)	1. Check “HORN WITH KEYLESS LOCK” setting in “WORK SUPPORT”.	BL-115
	2. Check Intelligent Key warning buzzer (engine room).	BL-142
	3. Check horn function.	BL-156
	4. Check IPDM E/R operation.	BL-156
	5. Replace Intelligent Key unit	BL-157

INTELLIGENT KEY SYSTEM

2. CHECK COMBINATION METER CIRCUIT

1. Turn ignition switch OFF.
2. Disconnect Intelligent Key unit connector and combination meter connector.
3. Check continuity Intelligent Key unit harness connector M75 terminal 9 and combination meter harness connector M20 terminal 50.

9 (R/G) - 50 (R/G) : Continuity should exist.

4. Check continuity Intelligent Key unit harness connector M75 terminal 9 and ground.

9 (R/G) - Ground : Continuity should not exist.

OK or NG

OK >> GO TO 3.

NG >> Repair or replace harness between Intelligent Key unit and combination meter.

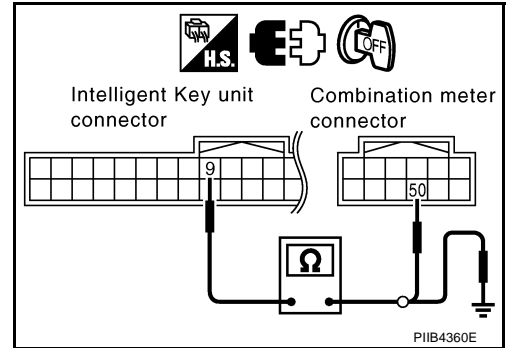

3. CHECK INTELLIGENT KEY UNIT INPUT SIGNAL

1. Connect combination meter connector.
2. Check voltage between Intelligent Key unit harness connector M75 terminal 9 and ground.

9 (R/G) - Ground : Batter voltage

OK or NG

OK >> Check condition of harness and connector.

NG >> Check combination meter. Refer to [DI-4, "COMBINATION METERS"](#).

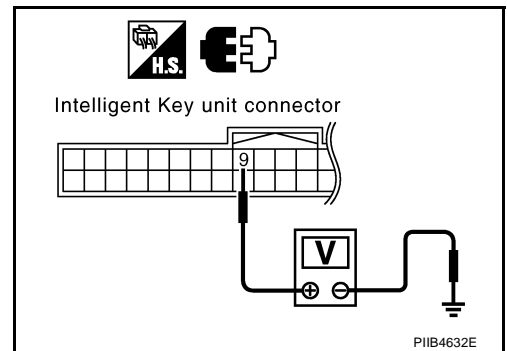

TRUNK LID OPENER

6. CHECK TRUNK LID OPENER SWITCH

1. Turn ignition switch OFF.
2. Disconnect trunk lid opener switch connector.
3. Check continuity between trunk lid opener switch connector M84 terminals 1 and 2.

Terminals		Trunk lid opener switch condition	Continuity
1	2	ON (Pushed)	Yes
		OFF (Released)	No

OK or NG

- OK >> GO TO 7.
 NG >> Replace trunk lid opener switch.

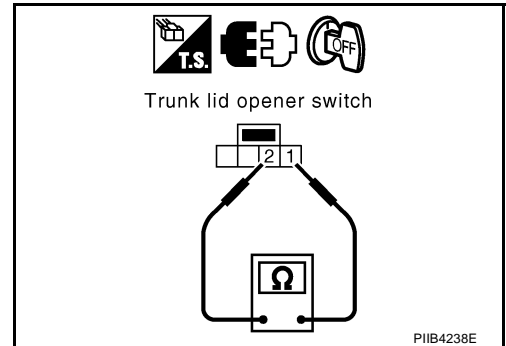

7. CHECK TRUNK LID OPENER CANCEL SWITCH

1. Disconnect trunk lid opener cancel switch connector.
2. Check continuity between trunk lid opener cancel switch connector M56 terminals 1 and 2.

Terminals		Trunk lid opener cancel switch condition	Continuity
1	2	ON	Yes
		OFF	No

OK or NG

- OK >> GO TO 8.
 NG >> Replace trunk lid opener cancel switch.

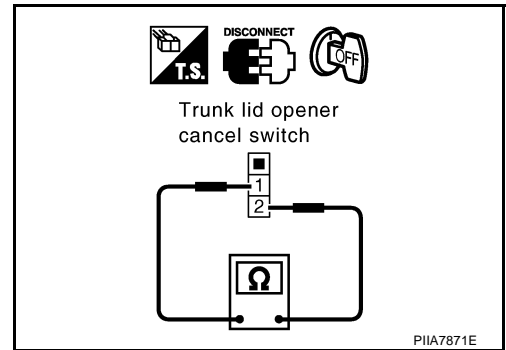

8. CHECK TRUNK LID OPENER SWITCH CIRCUIT

1. Disconnect BCM connector.
2. Turn on trunk lid opener switch.
3. Check continuity between BCM connector M1 terminal 30 and trunk lid opener switch connector M84 terminal 1.

BCM (A)		Trunk lid opener switch (B)		Continuity
Connector	Terminal	Connector	Terminal	
M1	30	M84	1	Yes

4. Check continuity between BCM connector M1 terminal 30 and ground.

BCM (A)		Ground	Continuity
Connector	Terminal		
M1	30		No

OK or NG

- OK >> GO TO 9.
 NG >> Repair harness or connector.

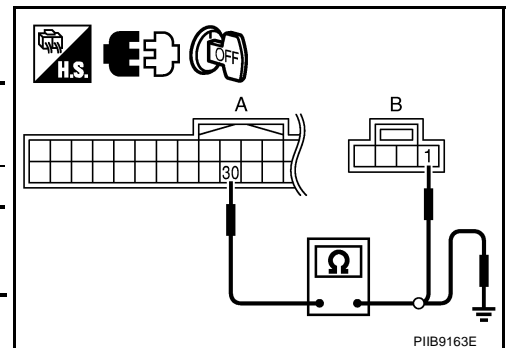

IVIS (INFINITI VEHICLE IMMOBILIZER SYSTEM-NATS)

Wiring Diagram — NATS —/With Intelligent Key System

NIS001KO

BL-NATS-01

— — — — — : DATA LINE

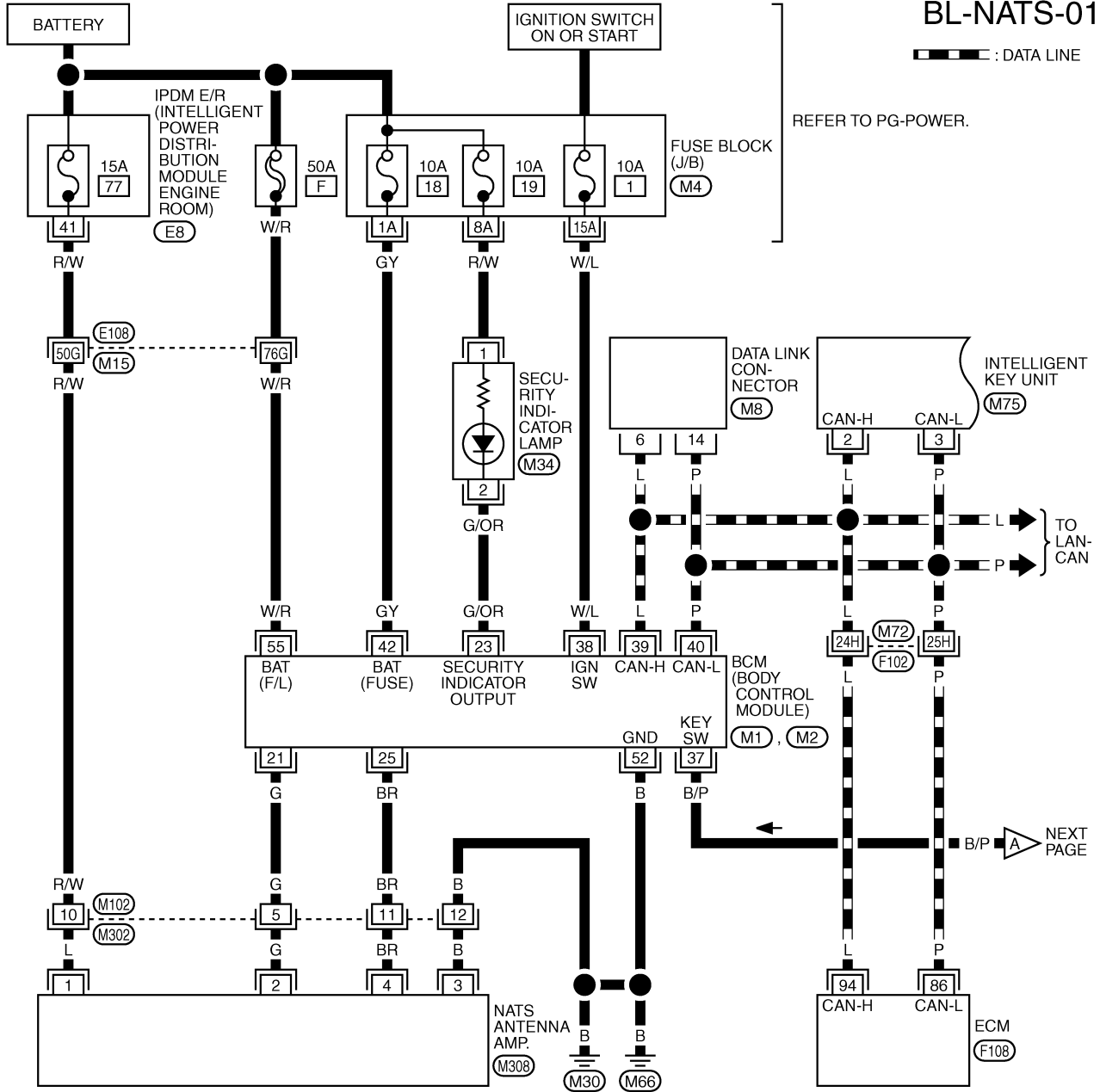

REFER TO PG-POWER.

TO LAN-CAN

NEXT PAGE

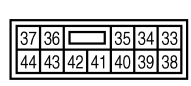
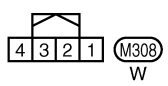
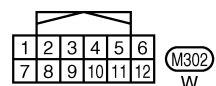
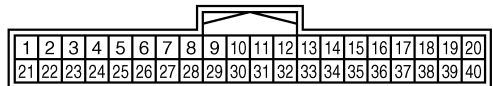
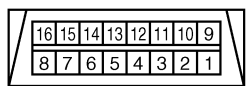

REFER TO THE FOLLOWING.
 (E108), (F102) -SUPER MULTIPLE JUNCTION (SMJ)
 (M4) -FUSE BLOCK-JUNCTION BOX (J/B)
 (M1), (M2), (F108) -ELECTRICAL UNITS

TIWM1487E

BODY REPAIR

NIS000DP

Body Sealing DESCRIPTION

The following figure shows the areas which are sealed at the factory. Sealant which has been applied to these areas should be smooth and free from cuts or gaps. Care should be taken not to apply an excess amount of sealant and not to allow other unaffected parts to come into contact with the sealant.

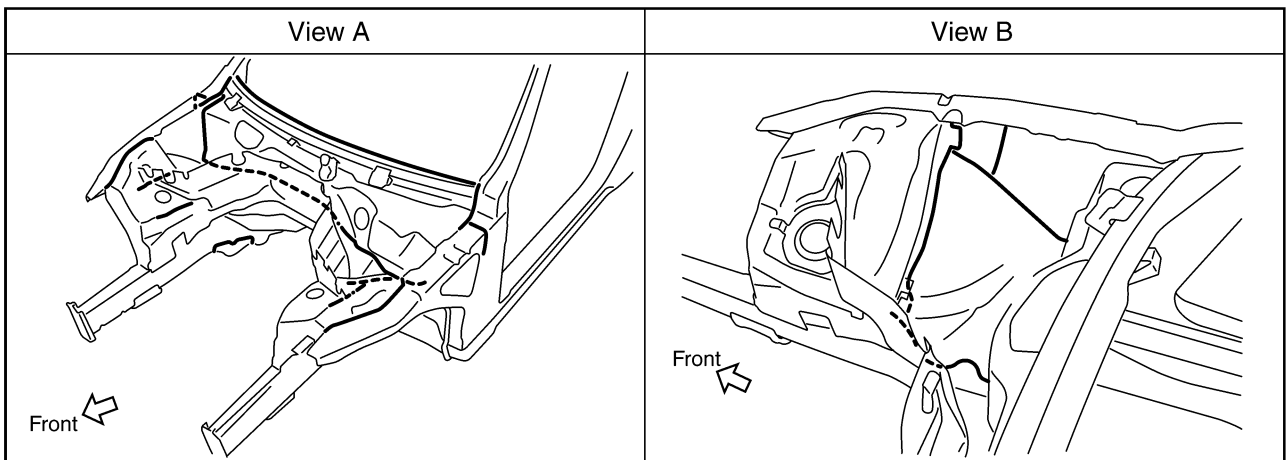
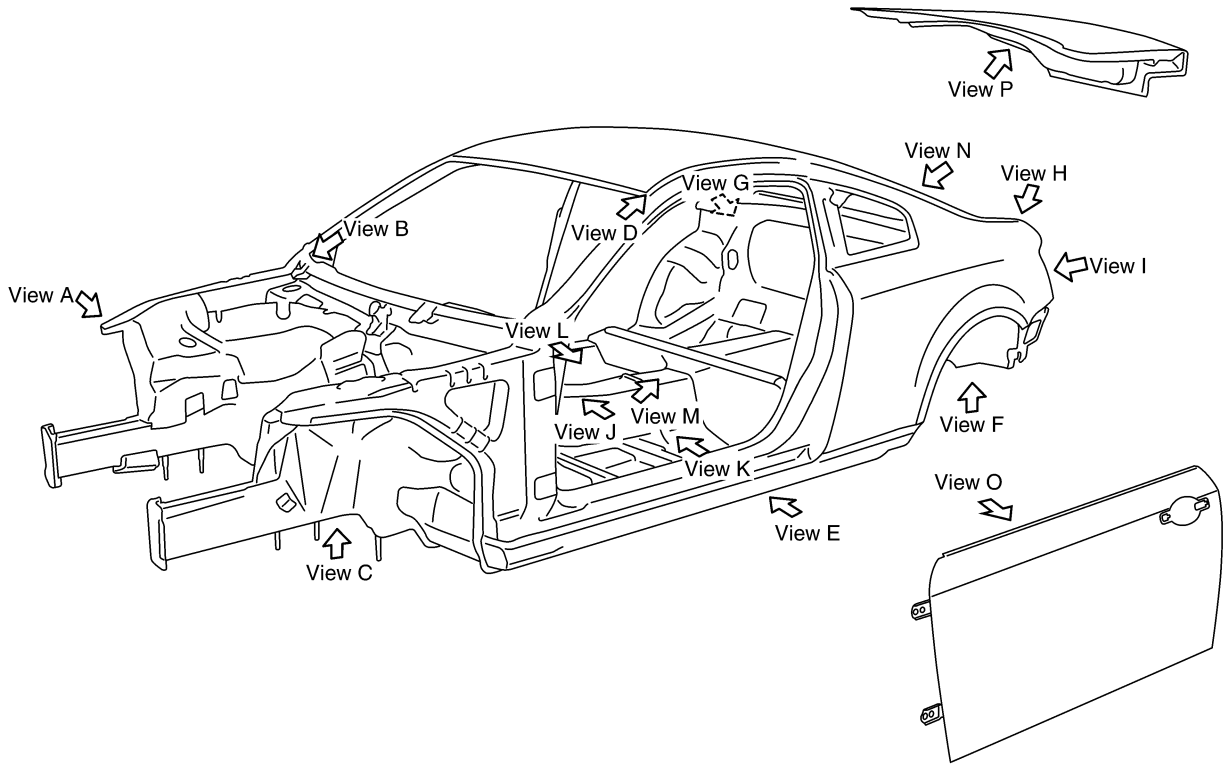

SIIA2134E

FRONT DISC BRAKE

- It is not necessary to remove torque member mounting bolts on torque member and brake hose except for disassembly or replacement of caliper assembly. In this case, hang cylinder body with a wire so as not to stretch brake hose.
- Do not damage piston boot.
- If any shim is subject to serious corrosion, replace it with a new one.
- Always replace shim and shim covers as a set when replacing brake pads.
- Keep rotor clean, from brake fluid.
- Burnish the brake pads and disc rotor mutually contacting surfaces after refinishing or replacing rotors, after replacing pads, or if a soft pedal occurs at very low mileage. Refer to [BR-26, "Brake Burnishing Procedure"](#).

Removal and Installation of Brake Pad

REMOVAL

1. Remove tires from vehicle with a power tool.
2. Remove lower sliding pin bolt.

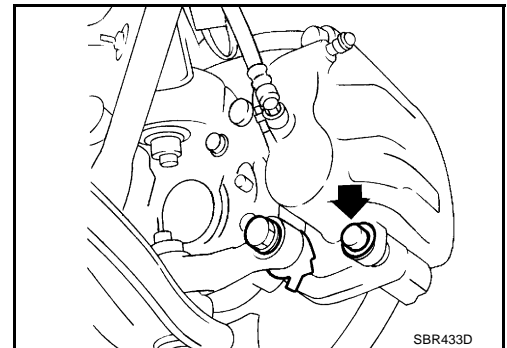

3. Hang cylinder body with a wire, and remove pads, shims, shim covers and pad retainers from torque member.

CAUTION:

- When removing pad retainer from torque member, lift pad retainer in the direction shown by arrow (shown in the figure) so as not to deform it.
- Do not damage piston boot.
- Keep rotor clean, from brake fluid.

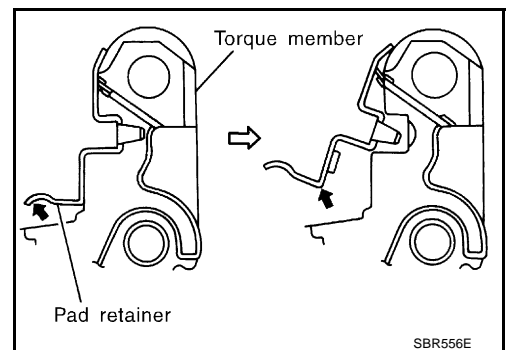

INSTALLATION

1. Apply PBC (Poly Butyl Cuprysil) grease or silicone-based grease between pad retainer and pad.
2. Install pad retainers and pad assemblies to torque member.

CAUTION:

Inner pad and outer pad have pad-return mechanism on upper side of pad retainer. When installing pad to torque member, be sure to install pad return lever to pad wear sensor securely.

3. Push the piston in so that the pad is firmly installed, and install cylinder body to torque member.

CAUTION:

When replacing pads with new ones, press in piston until pads can be installed. In this case, carefully monitor brake fluid level in reservoir tank because brake fluid will return to master cylinder reservoir tank.

NOTE:

Use a disc brake piston tool (commercial service tool) to easily press piston.

4. Install lower sliding pin bolt, and tighten it to the specified torque. Refer to [BR-21, "Components"](#).
5. Secure disc rotor with wheel nuts. Depress brake pedal a few times until it gets a responsive touch.

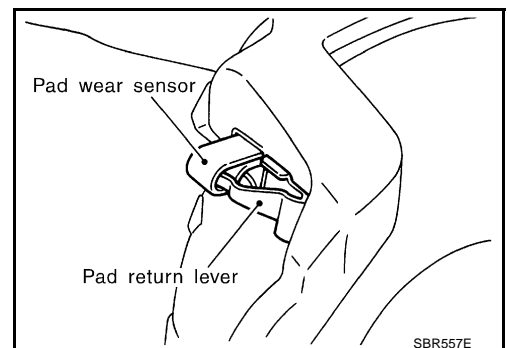

TROUBLE DIAGNOSIS

[VDC/TCS/ABS]

BRC-VDC-06

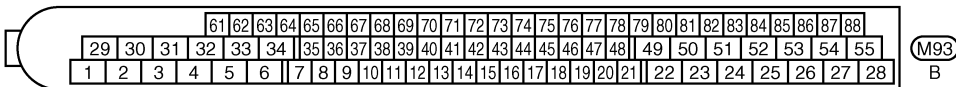
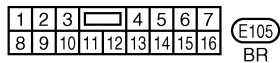
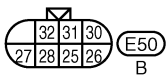
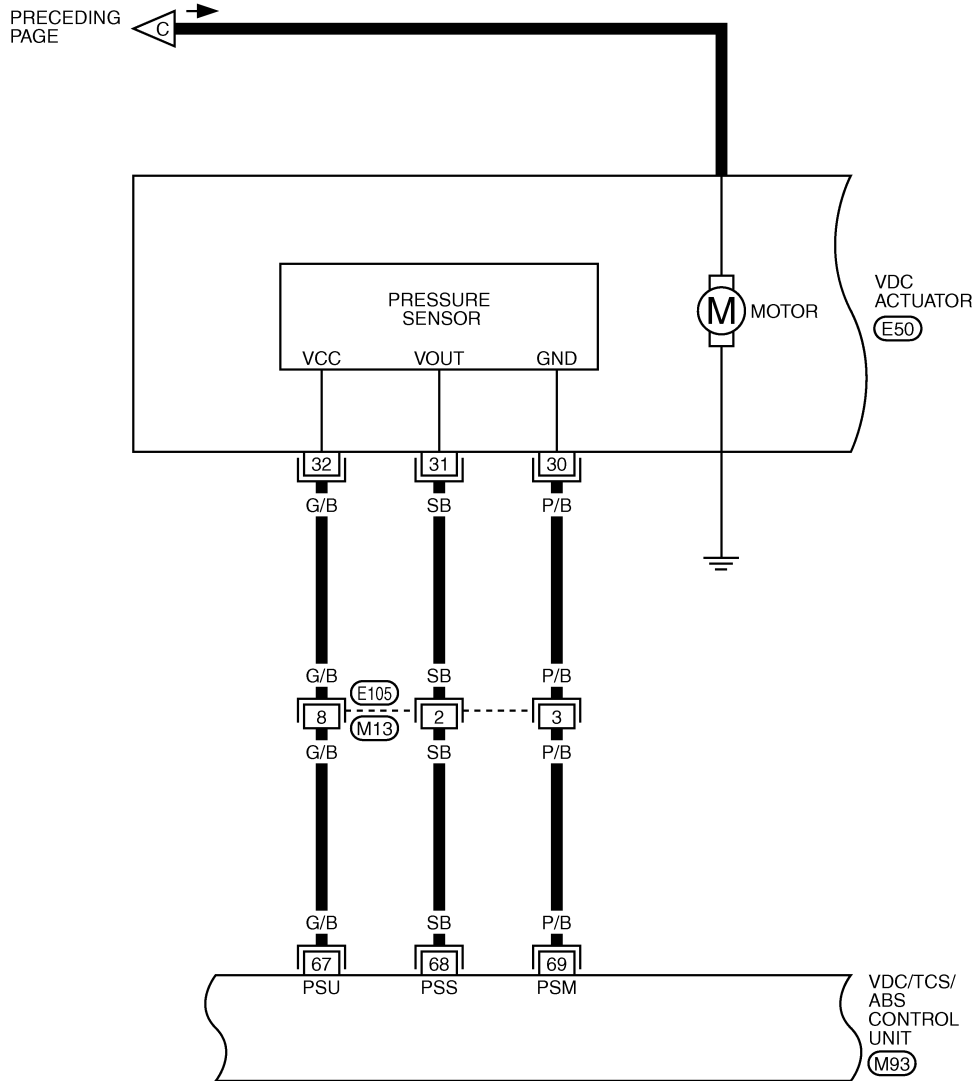

TFWM0141E

2. CHECK RAS CONTROL UNIT CIRCUIT

1. Perform RAS control unit self-diagnosis. Repair or replace items indicated, then perform RAS control unit self-diagnosis again. Refer to [STC-23, "Self-Diagnosis"](#) .
2. Perform VDC/TCS/ABS control unit self diagnosis.

OK or NG

OK >> INSPECTION END

NG >> ● Repair or replace malfunctioning components.

- Perform the self-diagnosis, and make sure that the result shows "NO DTC IS DETECTED".

**CAN Communication Circuit
INSPECTION PROCEDURE**

NFS0007F

1. CHECK CONNECTOR

1. Turn ignition switch OFF and disconnect VDC/TCS/ABS control unit connector and steering angle sensor connector. Check terminal for deformation, disconnection, looseness, and so on. If any malfunction is found, repair or replace terminal.
2. Securely reconnect connectors and perform self-diagnosis.

Self-diagnostic results
CAN COMM CIRCUIT
ST ANG SEN COM CIR

Is above displayed in the self-diagnosis item?

YES >> Print out self-diagnostic results and go to [LAN-47, "CAN System Specification Chart"](#) .

NO >> Connector terminal connection is loose, damaged, open or shorted.

**Component Inspection
VDC OFF SWITCH**

NFS0007G

- Turn ignition switch OFF and disconnect VDC OFF switch connector. Check continuity between terminal 1 and terminal 2.

1 - 2:

Pressing switch will establish continuity, releasing it will break continuity.

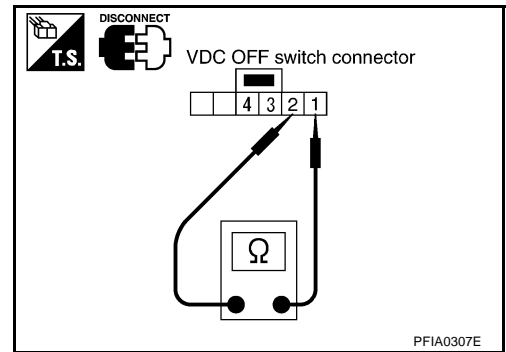

ABS MOTOR RELAY AND ACTUATOR RELAY

- Turn ignition switch OFF and disconnect the VDC relay box connector E47, E48, E222.
- Apply a voltage of 12V between the ABS motor relay terminal 8 and the actuator relay terminal 7 and then check the continuity between the following terminals.

ABS motor relay	Between terminal 4 to 10	Continuity should exist.
Actuator relay	Between terminal 9 to 16	Continuity should exist.

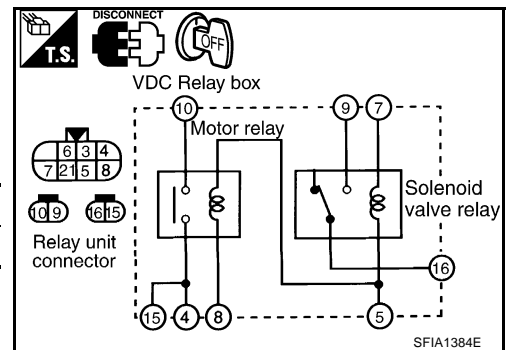

PRECAUTIONS

PRECAUTIONS

PFP:00001

Precautions for Battery Service

NBS000LD

Before disconnecting the battery, lower both the driver and passenger windows. This will prevent any interference between the window edge and the vehicle when the door is opened/closed. During normal operation, the window slightly raises and lowers automatically to prevent any window to vehicle interference. The automatic window function will not work with the battery disconnected.

Precautions for Supplemental Restraint System (SRS) “AIR BAG” and “SEAT BELT PRE-TENSIONER”

NBS000LE

The Supplemental Restraint System such as “AIR BAG” and “SEAT BELT PRE-TENSIONER”, used along with a front seat belt, helps to reduce the risk or severity of injury to the driver and front passenger for certain types of collision. This system includes seat belt switch inputs and dual stage front air bag modules. The SRS system uses the seat belt switches to determine the front air bag deployment, and may only deploy one front air bag, depending on the severity of a collision and whether the front occupants are belted or unbelted. Information necessary to service the system safely is included in the SRS and SB section of this Service Manual.

WARNING:

- To avoid rendering the SRS inoperative, which could increase the risk of personal injury or death in the event of a collision which would result in air bag inflation, all maintenance must be performed by an authorized NISSAN/INFINITI dealer.
- Improper maintenance, including incorrect removal and installation of the SRS, can lead to personal injury caused by unintentional activation of the system. For removal of Spiral Cable and Air Bag Module, see the SRS section.
- Do not use electrical test equipment on any circuit related to the SRS unless instructed to in this Service Manual. SRS wiring harnesses can be identified by yellow and/or orange harnesses or harness connectors.

Precautions for Liquid Gasket REMOVAL OF LIQUID GASKET SEALING

NBS000LF

- After removing mounting bolts and nuts, separate the mating surface using seal cutter (SST) and remove old liquid gasket sealing.

CAUTION:

Be careful not to damage the mating surfaces.

- In areas where seal cutter (SST) is difficult to use, use plastic hammer to lightly tap (1) seal cutter where liquid gasket is applied. Use plastic hammer to slide seal cutter (2) by tapping on the side.

CAUTION:

If for some unavoidable reason tool such as flat-bladed screwdriver is used, be careful not to damage the mating surfaces.

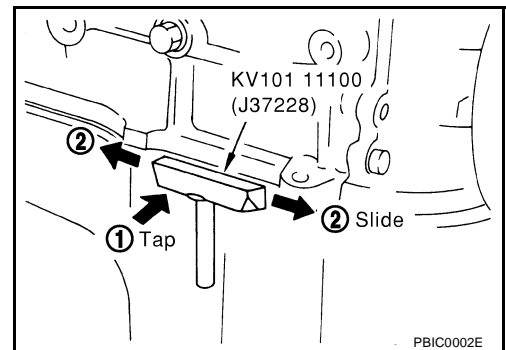

LIQUID GASKET APPLICATION PROCEDURE

1. Using scraper, remove old liquid gasket adhering to the liquid gasket application surface and the mating surface.
 - Remove liquid gasket completely from the groove of the liquid gasket application surface, mounting bolts, and bolt holes.
2. Wipe the liquid gasket application surface and the mating surface with white gasoline (lighting and heating use) to remove adhering moisture, grease and foreign materials.

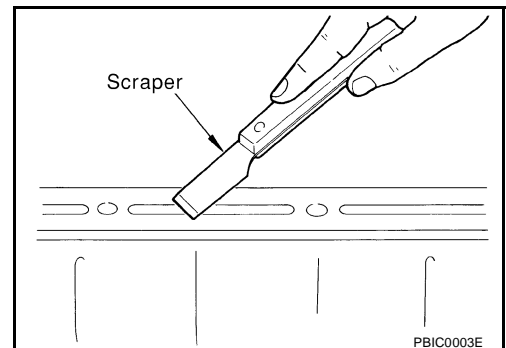

SELF-DIAG RESULTS	47	COMPASS	58
Trouble Diagnosis	47	System Description	58
HOW TO PERFORM TROUBLE DIAGNOSIS ...	47	DIRECTION DISPLAY	58
Symptom Chart	48	Wiring Diagram — COMPASS —	59
Power Supply and Ground Circuit Inspection	49	Fail-Safe System	60
Combination Meter Buzzer Circuit Inspection	50	DESCRIPTION	60
Driver Side Door Switch Signal Inspection	50	Power Supply and Ground Circuit Inspection	60
Key Switch Signal Inspection (Without Intelligent		Compass Does not Display	60
Key)	51	Compass Display “— —”	61
Key Switch and Ignition Knob Switch Signal Inspec-		Forward Direction Indication Slips Off The Mark or	
tion (With Intelligent Key, When Mechanical Key Is		Incorrect	62
Used)	53	Compass Reading Remains Unchanged	62
Lighting Switch Signal Inspection	54	Calibration Procedure for Compass	63
Seat Belt Buckle Switch (Driver Side) Signal Inspec-		CORRECTION FUNCTIONS OF COMPASS	64
tion	54	INITIAL CORRECTION PROCEDURE FOR	
Component Inspection	56	COMPASS	64
DRIVER SIDE DOOR SWITCH	56	Removal and Installation of Compass	64
KEY SWITCH	56	REMOVAL	64
KEY SWITCH AND IGNITION KNOB SWITCH..	56	INSTALLATION	64
SEAT BELT BUCKLE SWITCH (DRIVER SIDE)..	56	CLOCK	65
CAN COMMUNICATION	57	Removal and Installation of Clock	65
System Description	57	REMOVAL	65
CAN Communication Unit	57	INSTALLATION	65

A/T INDICATOR

A/T INDICATOR

PFP:24814

System Description

NKS000R1

A/T position is displayed in the segment display in the combination meter.

MANUAL MODE

- Combination meter reads manual mode signal and shift-up/down signal from A/T device (manual mode switch), and transmits the signals to TCM with CAN communication.
- TCM processes manual mode signal and shift-up/down signal, and transmits A/T position indicator signal and manual mode indicator signal to combination meter with CAN communication.
- Combination meter indicates A/T gear position and manual mode indicator when receiving A/T position indicator signal and manual mode indication signal.

NOT MANUAL MODE

- Combination meter reads not manual mode signal from A/T device (manual mode switch), and transmits the signals to TCM with CAN communication.
- TCM transmits A/T position indicator signal to combination meter with CAN communication.
- Combination meter indicates A/T shift position when receiving A/T position indicator signal.

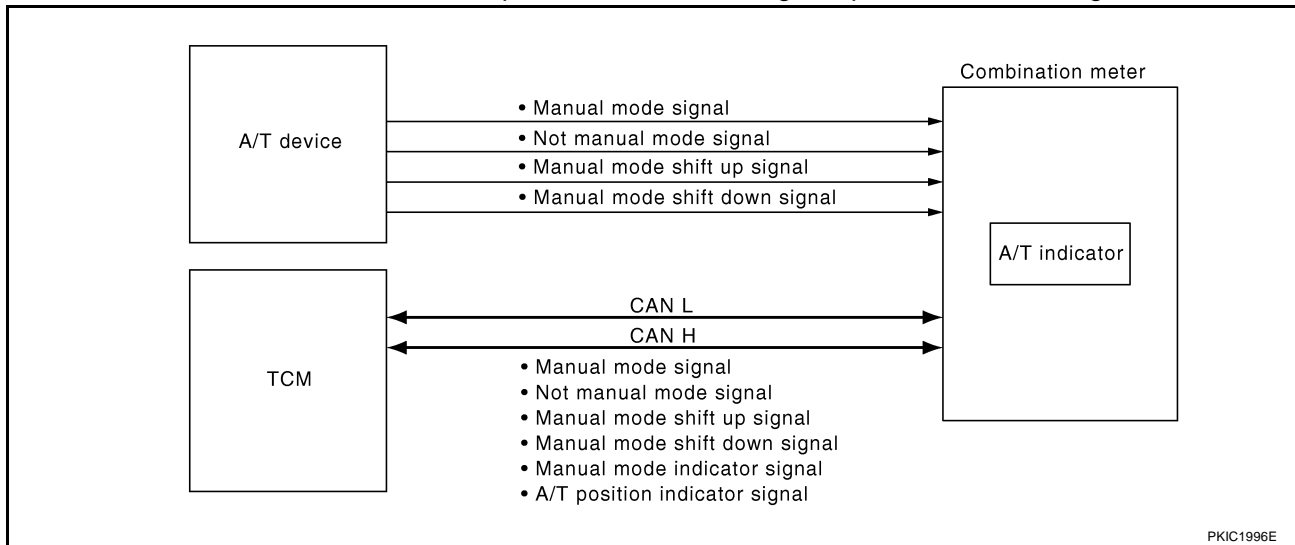

CLOCK

EVAPORATIVE EMISSION SYSTEM

EVAPORATIVE EMISSION SYSTEM

PFP:14950

Description SYSTEM DESCRIPTION

NBS000MM

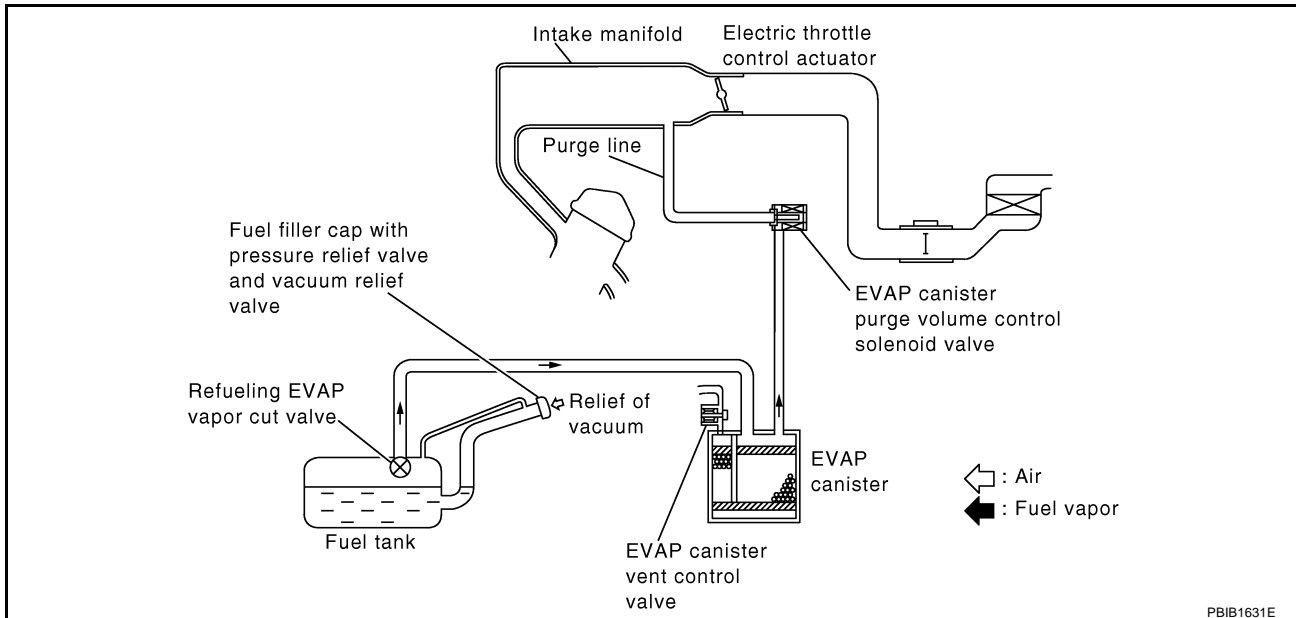

The evaporative emission system is used to reduce hydrocarbons emitted into the atmosphere from the fuel system. This reduction of hydrocarbons is accomplished by activated charcoals in the EVAP canister. The fuel vapor in the sealed fuel tank is led into the EVAP canister which contains activated carbon and the vapor is stored there when the engine is not operating or when refueling to the fuel tank. The vapor in the EVAP canister is purged by the air through the purge line to the intake manifold when the engine is operating. EVAP canister purge volume control solenoid valve is controlled by ECM. When the engine operates, the flow rate of vapor controlled by EVAP canister purge volume control solenoid valve is proportionally regulated as the air flow increases. EVAP canister purge volume control solenoid valve also shuts off the vapor purge line during decelerating and idling.

ON BOARD DIAGNOSTIC (OBD) SYSTEM

NOTE:

Do not release the accelerator pedal for 10 seconds if MIL may start blinking on the halfway of this 10 seconds. This blinking is displaying SRT status and is continued for another 10 seconds. For the details, refer to [EC-56, "How to Display SRT Status"](#) .

4. Fully release the accelerator pedal.
ECM has entered to Diagnostic Test Mode II (Self-diagnostic results).

NOTE:

Wait until the same DTC (or 1st trip DTC) appears to confirm all DTCs certainly.

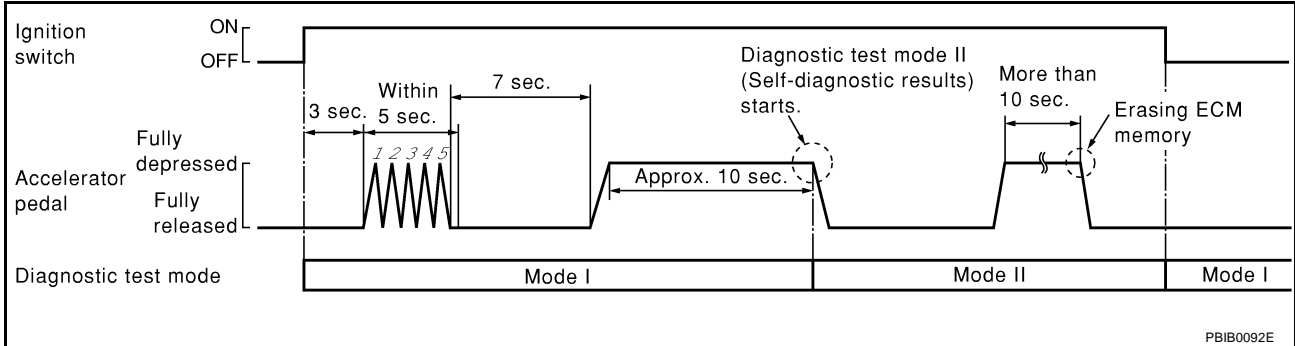

How to Erase Diagnostic Test Mode II (Self-diagnostic Results)

1. Set ECM in Diagnostic Test Mode II (Self-diagnostic results).
Refer to [EC-63, "How to Set Diagnostic Test Mode II \(Self-diagnostic Results\)"](#) .
2. Fully depress the accelerator pedal and keep it for more than 10 seconds.
The emission-related diagnostic information has been erased from the backup memory in the ECM.
3. Fully release the accelerator pedal, and confirm the DTC 0000 is displayed.

TROUBLE DIAGNOSIS

Engine Control Component Parts Location (A/T models)

NBS000NE

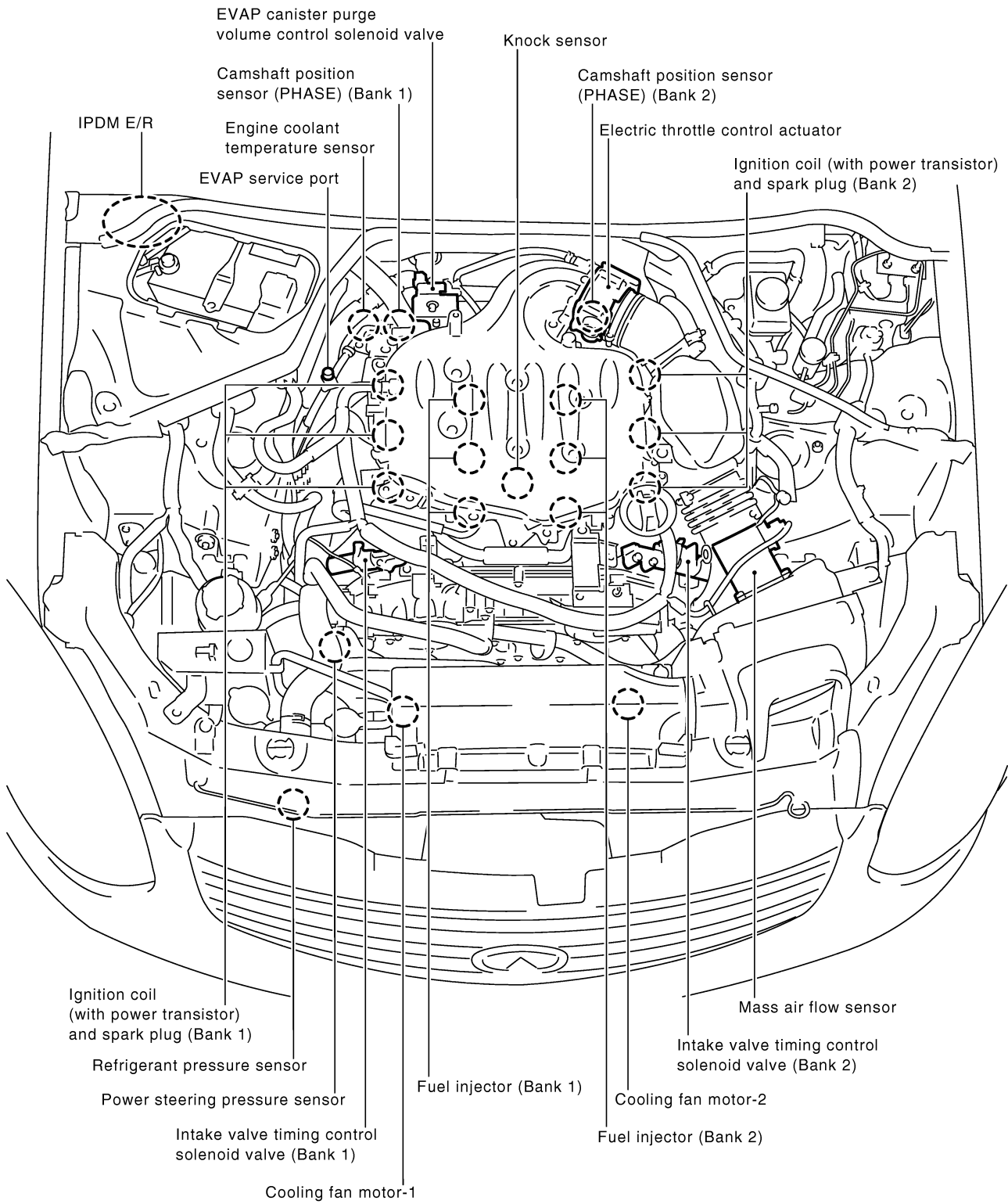

PBIB3101E

TROUBLE DIAGNOSIS

Monitored item [Unit]	ECM INPUT SIG- NALS	MAIN SIG- NALS	Description	Remarks
I/P PULLY SPD [rpm]			<ul style="list-style-type: none"> Indicates the engine speed computed from the turbine revolution sensor signal. 	
VEHICLE SPEED [km/h] or [mph]			<ul style="list-style-type: none"> Indicates the vehicle speed computed from the revolution sensor signal. 	
IDL A/V LEARN [YET/CMPLT]			<ul style="list-style-type: none"> Display the condition of Idle Air Volume Learning YET: Idle Air Volume Learning has not been performed yet. CMPLT: Idle Air Volume Learning has already been performed successfully. 	
TRVL AFTER MIL [km] or [mile]			<ul style="list-style-type: none"> Distance traveled while MIL is activated. 	
ENG OIL TEMP* [°C] or [°F]			<ul style="list-style-type: none"> The engine oil temperature (determined by the signal voltage of the engine oil temperature sensor) is displayed. 	<ul style="list-style-type: none"> This sensor is not for controlling the engine system, nor for the on board diagnosis.
A/F S1 HTR(B1) [%]			<ul style="list-style-type: none"> Indicates A/F sensor 1 heater control value computed by ECM according to the input signals. 	
A/F S1 HTR(B2) [%]			<ul style="list-style-type: none"> The current flow to the heater becomes larger as the value increases. 	
AC PRESS SEN [V]			<ul style="list-style-type: none"> The signal voltage from the refrigerant pressure sensor is displayed. 	
VHCL SPEED SE [km/h] or [mph]			<ul style="list-style-type: none"> The vehicle speed computed from the vehicle speed signal sent from TCM is displayed. 	
SET VHCL SPD [km/h] or [mph]			<ul style="list-style-type: none"> The preset vehicle speed is displayed. 	
MAIN SW [ON/OFF]			<ul style="list-style-type: none"> Indicates [ON/OFF] condition from MAIN switch signal. 	
CANCEL SW [ON/OFF]			<ul style="list-style-type: none"> Indicates [ON/OFF] condition from CANCEL switch signal. 	
RESUME/ACC SW [ON/OFF]			<ul style="list-style-type: none"> Indicates [ON/OFF] condition from RESUME/ACCELERATE switch signal. 	
SET SW [ON/OFF]			<ul style="list-style-type: none"> Indicates [ON/OFF] condition from SET/COAST switch signal. 	
BRAKE SW1 [ON/OFF]			<ul style="list-style-type: none"> Indicates [ON/OFF] condition from ASCD brake switch signal and ASCD clutch switch signal (M/T) 	
BRAKE SW2 [ON/OFF]			<ul style="list-style-type: none"> Indicates [ON/OFF] condition of stop lamp switch signal. 	
VHCL SPD CUT [NON/CUT]			<ul style="list-style-type: none"> Indicates the vehicle cruise condition. NON: Vehicle speed is maintained at the ASCD set speed. CUT: Vehicle speed increased to excessively high compared with the ASCD set speed, and ASCD operation is cut off. 	
LO SPEED CUT [NON/CUT]			<ul style="list-style-type: none"> Indicates the vehicle cruise condition. NON: Vehicle speed is maintained at the ASCD set speed. CUT: Vehicle speed decreased to excessively low compared with the ASCD set speed, and ASCD operation is cut off. 	

POWER SUPPLY AND GROUND CIRCUIT

For detailed ground distribution information, refer to [PG-28, "Ground Distribution"](#).

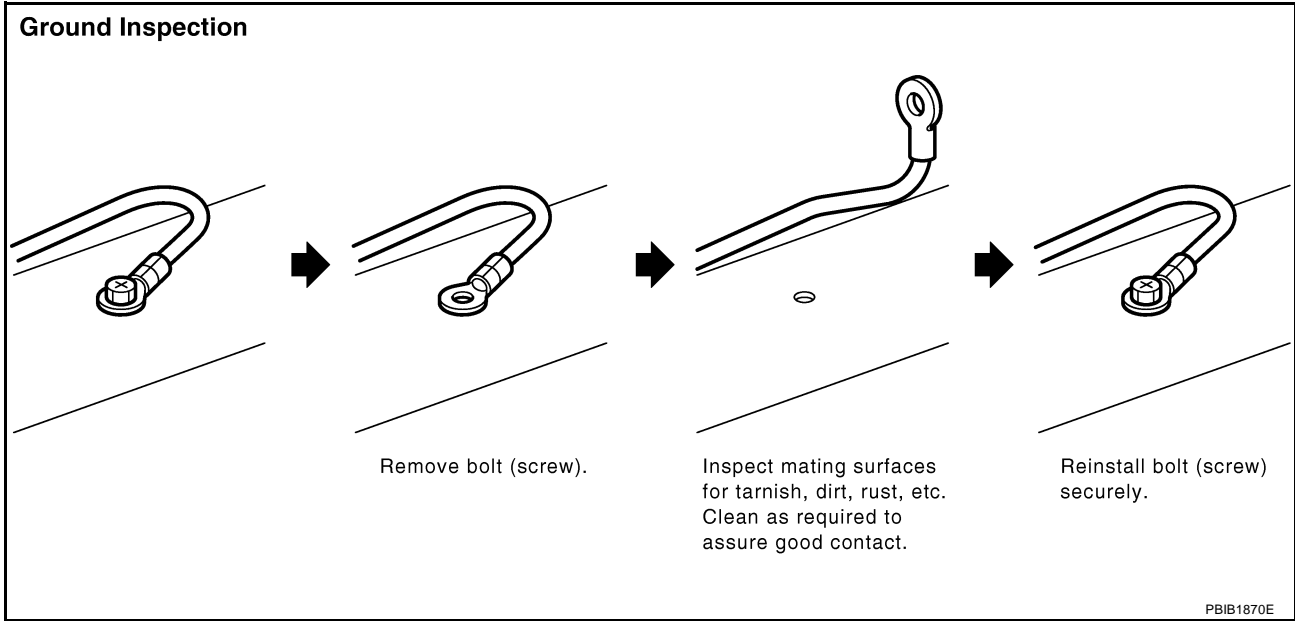

DTC P0075, P0081 IVT CONTROL SOLENOID VALVE

NBS000VS

Wiring Diagram BANK 1

EC-IVCB1-01

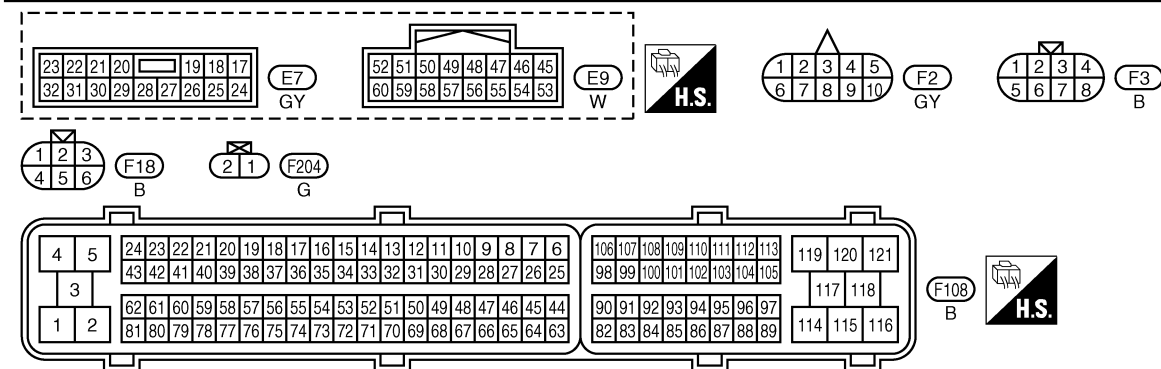
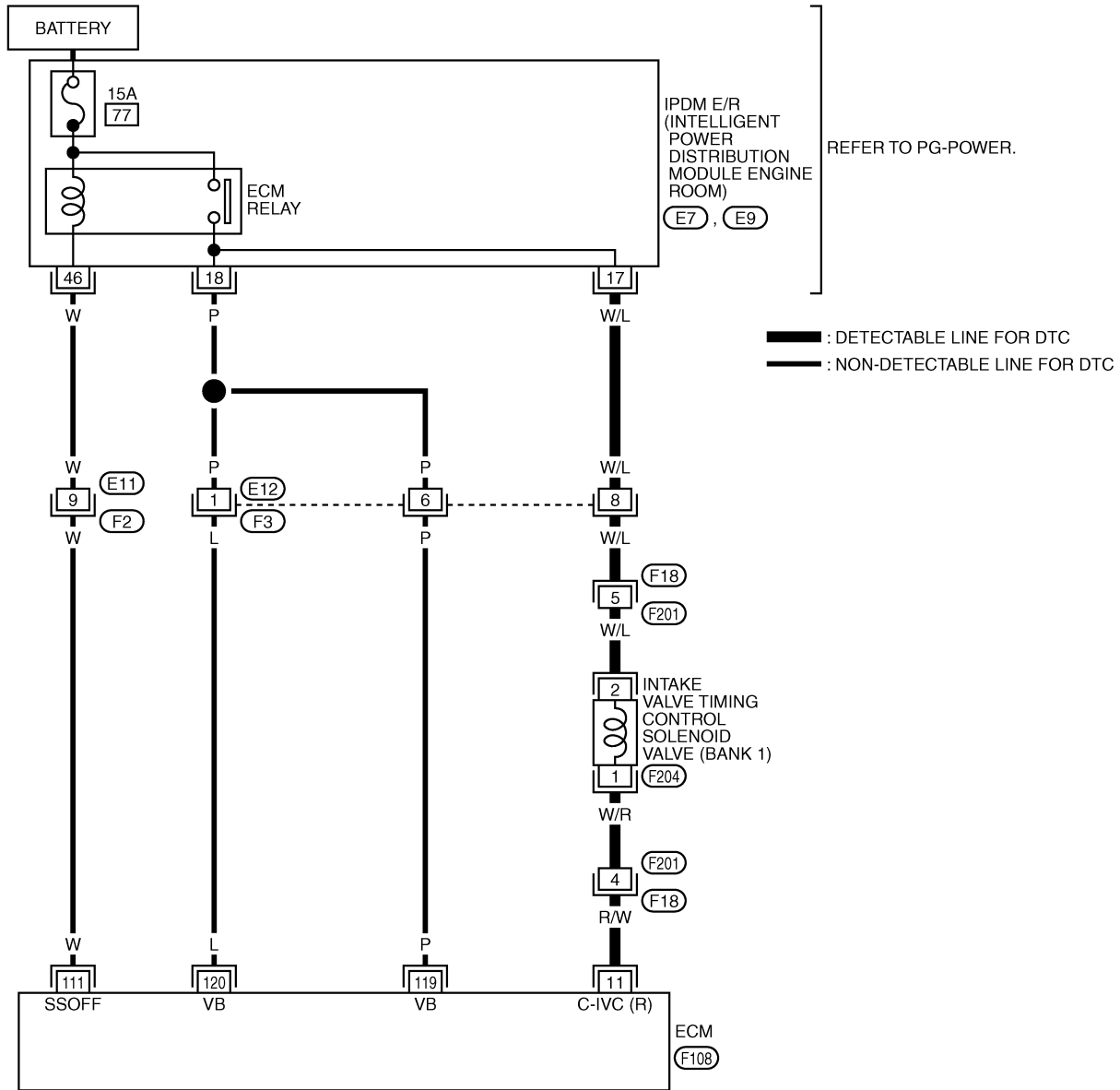

TBWM0348E

DTC P0112, P0113 IAT SENSOR

Wiring Diagram

NBS000PG

EC-IATS-01

: DETECTABLE LINE FOR DTC
 : NON-DETECTABLE LINE FOR DTC

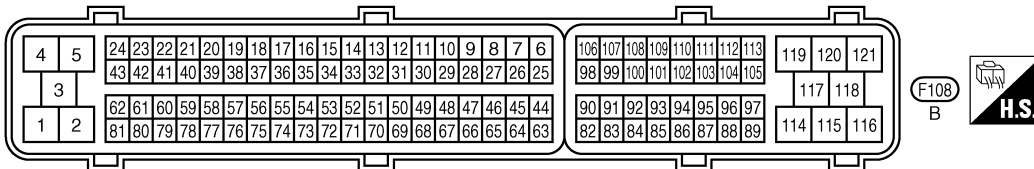
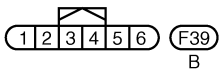
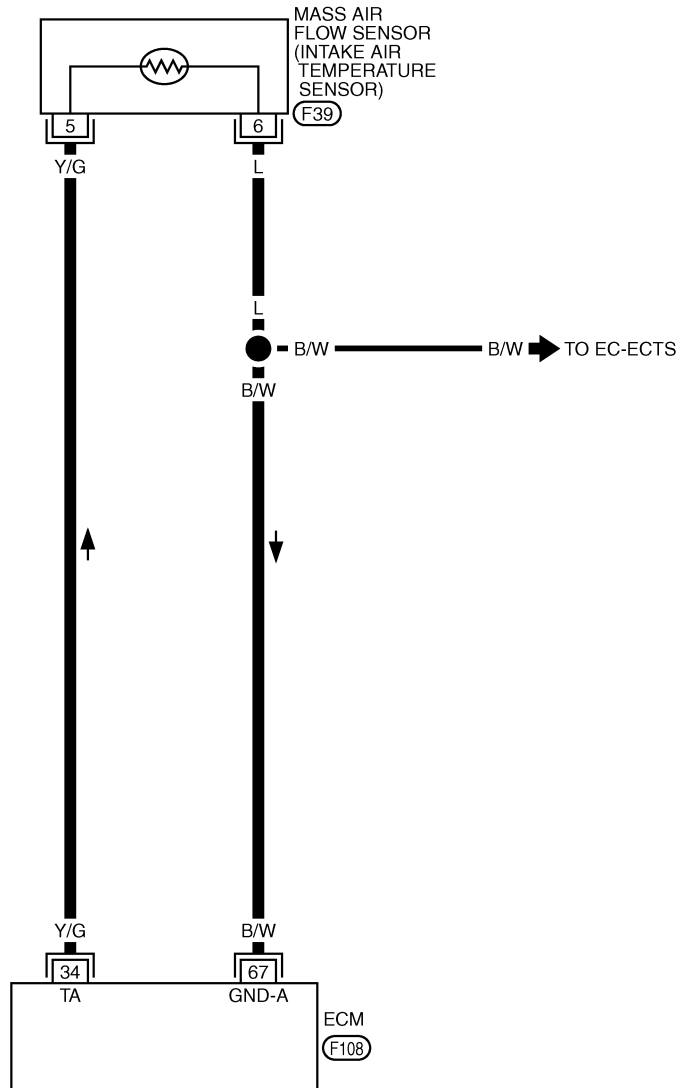

TBWT0263E

DTC P0130, P0150 A/F SENSOR 1

Removal and Installation AIR FUEL RATIO (A/F) SENSOR 1

NBS000YW

Refer to [EM-25, "EXHAUST MANIFOLD AND THREE WAY CATALYST"](#) .

DTC Confirmation Procedure

NOTE:

If DTC confirmation Procedure has been previously conducted, always turn ignition switch OFF and wait at least 10 seconds before conducting the next test.

WITH CONSULT-II

TESTING CONDITION:

For better results, perform “DTC WORK SUPPORT” at a temperature of 0 to 30 °C (32 to 86 °F).

1. Turn ignition switch ON and select “DATA MONITOR” mode with CONSULT-II.
2. Start engine and warm it up to the normal operating temperature.
3. Turn ignition switch OFF and wait at least 10 seconds.
4. Start engine and keep the engine speed between 3,500 and 4,000 rpm for at least 1 minute under no load.
5. Let engine idle for 1 minute.
6. Make sure that “COOLAN TEMP/S” indicates more than 70°C (158°F).
If not, warm up engine and go to next step when “COOLAN TEMP/S” indication reaches to 70°C (158°F).
7. Open engine hood.
8. Select “HO2S2 (B1) P1147” (for DTC P0137) or “HO2S2 (B2) P1167” (for DTC P0157) of “HO2S2” in “DTC WORK SUPPORT” mode with CONSULT-II.
9. Start engine and following the instruction of CONSULT-II.

DATA MONITOR	
MONITOR	NO DTC
ENG SPEED	XXX rpm
COOLAN TEMP/S	XXX °C

SEF174Y

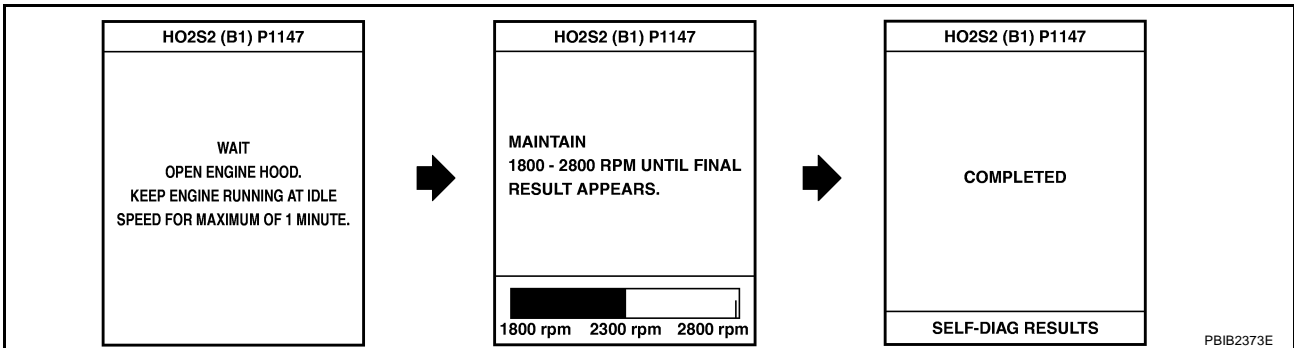

NOTE:

It will take at most 10 minutes “COMPLETED” is displayed.

10. Make sure that “OK” is displayed after touching “SELF-DIAG RESULTS”.
If “NG” is displayed, refer to [EC-293, "Diagnostic Procedure"](#).
If “CAN NOT BE DIAGNOSED” is displayed, perform the following.
 - a. Turn ignition switch OFF and leave the vehicle in a cool place (soak the vehicle).
 - b. Return to step 1.

Overall Function Check

Use this procedure to check the overall function of the heated oxygen sensor 2 circuit. During this check, a 1st trip DTC might not be confirmed.

WITH GST

1. Start engine and warm it up to the normal operating temperature.
2. Turn ignition switch OFF and wait at least 10 seconds.
3. Start engine and keep the engine speed between 3,500 and 4,000 rpm for at least 1 minute under no load.
4. Let engine idle for 1 minute.
5. Set voltmeter probes between ECM terminal 74 [HO2S2 (B1) signal] or 55 [HO2S2 (B2) signal] and ground.

DTC P0139, P0159 HO2S2

- Before installing new oxygen sensor, clean exhaust system threads using Oxygen Sensor Thread Cleaner tool J-43897-18 or J-43897-12 and approved anti-seize lubricant.

⊗ Without CONSULT-II

1. Start engine and warm it up to the normal operating temperature.
2. Turn ignition switch OFF and wait at least 10 seconds.
3. Start engine and keep the engine speed between 3,500 and 4,000 rpm for at least 1 minute under no load.
4. Let engine idle for 1 minute.
5. Set voltmeter probes between ECM terminal 74 [HO2S2 (B1) signal] or 55 [HO2S2 (B2) signal] and ground.
6. Check the voltage when revving up to 4,000 rpm under no load at least 10 times.
(Depress and release accelerator pedal as soon as possible.)
The voltage should be above 0.78V at least once during this procedure.
If the voltage is above 0.78V at step 6, step 7 is not necessary.
7. Keep vehicle at idling for 10 minutes, then check voltage. Or check the voltage when coasting from 80 km/h (50 MPH) in D position (A/T), 4th gear position (M/T).
The voltage should be below 0.18V at least once during this procedure.
8. If NG, replace heated oxygen sensor 2.

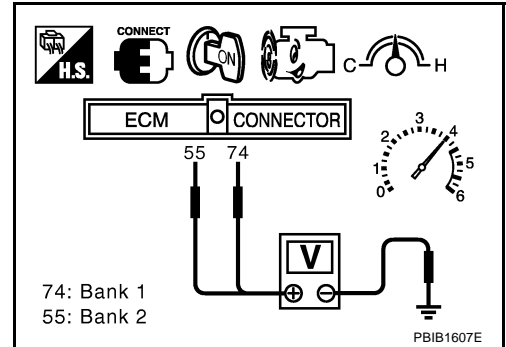

CAUTION:

- Discard any heated oxygen sensor which has been dropped from a height of more than 0.5 m (19.7 in) onto a hard surface such as a concrete floor; use a new one.
- Before installing new oxygen sensor, clean exhaust system threads using Oxygen Sensor Thread Cleaner tool J-43897-18 or J-43897-12 and approved anti-seize lubricant.

Removal and Installation HEATED OXYGEN SENSOR 2

NBS000QW

Refer to [EM-25, "EXHAUST MANIFOLD AND THREE WAY CATALYST"](#) .

DTC P0182, P0183 FTT SENSOR

4. CHECK FUEL TANK TEMPERATURE SENSOR GROUND CIRCUIT FOR OPEN AND SHORT

1. Turn ignition switch OFF.
2. Check harness continuity between "fuel level sensor unit and fuel pump" terminal 5 and ground. Refer to Wiring Diagram.

Continuity should exist.

3. Also check harness for short to power.

OK or NG

- OK >> GO TO 6.
NG >> GO TO 5.

5. DETECT MALFUNCTIONING PART

Check the following.

- Harness connectors B1, M12
- Harness for open or short between "fuel level sensor unit and fuel pump" and ground.

>> Repair open circuit or short to power in harness or connector.

6. CHECK FUEL TANK TEMPERATURE SENSOR

Refer to [EC-348, "Component Inspection"](#).

OK or NG

- OK >> GO TO 7.
NG >> Replace fuel level sensor unit.

7. CHECK INTERMITTENT INCIDENT

Refer to [EC-151, "TROUBLE DIAGNOSIS FOR INTERMITTENT INCIDENT"](#).

>> INSPECTION END

Component Inspection FUEL TANK TEMPERATURE SENSOR

NBS000RH

1. Remove fuel level sensor unit.
2. Check resistance between "fuel level sensor unit and fuel pump" terminals 4 and 5 by heating with hot water as shown in the figure.

Temperature °C (°F)	Resistance kΩ
20 (68)	2.3 - 2.7
50 (122)	0.79 - 0.90

3. If NG, replace fuel level sensor unit.

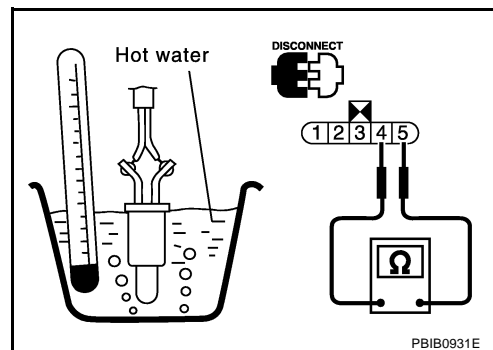

NBS000RI

Removal and Installation FUEL TANK TEMPERATURE SENSOR

Refer to [FL-5, "FUEL LEVEL SENSOR UNIT, FUEL FILTER AND FUEL PUMP ASSEMBLY"](#).

DTC P0340, P0345 CMP SENSOR (PHASE)

NBS000SD

Wiring Diagram BANK 1

EC-PHSB1-01

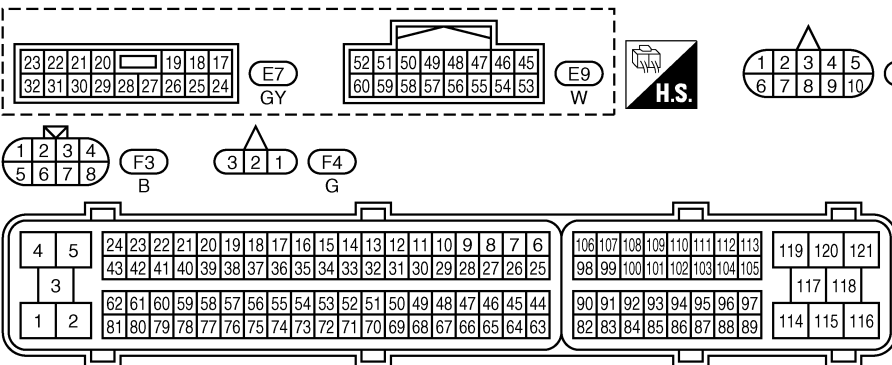
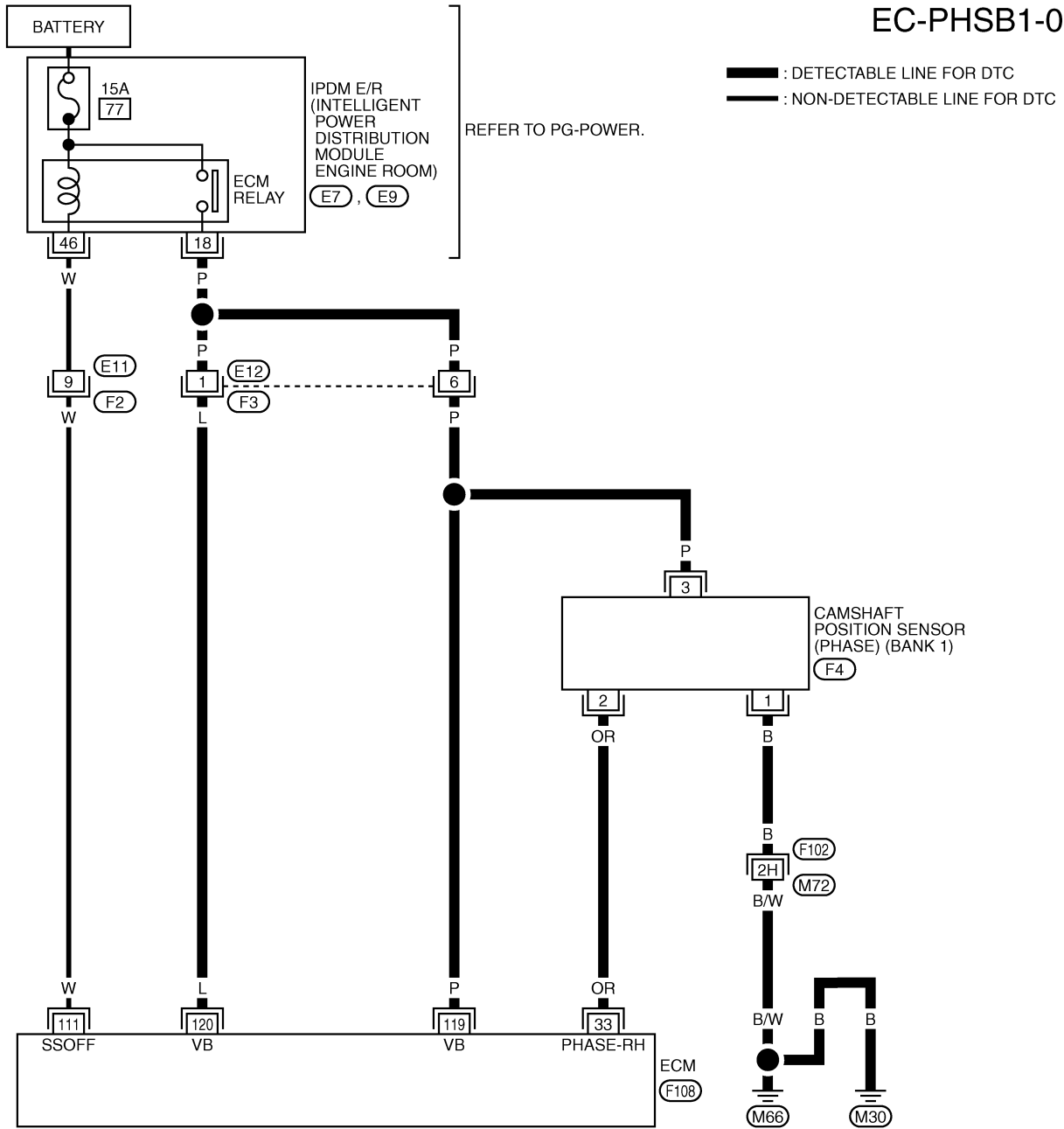

REFER TO THE FOLLOWING.

(F102) -SUPER MULTIPLE JUNCTION (SMJ)

TBWM0343E

DTC P0443 EVAP CANISTER PURGE VOLUME CONTROL SOLENOID VALVE

4. CHECK EVAP CONTROL SYSTEM PRESSURE SENSOR CONNECTOR

Check connectors for water.

Water should not exist.

OK or NG

- OK >> GO TO 5.
- NG >> Replace EVAP control system pressure sensor.

5. CHECK EVAP CONTROL SYSTEM PRESSURE SENSOR

Refer to [EC-448, "Component Inspection"](#) .

OK or NG

- OK (With CONSULT-II)>>GO TO 6.
- OK (Without CONSULT-II)>>GO TO 7.
- NG >> Replace EVAP control system pressure sensor.

6. CHECK EVAP CANISTER PURGE VOLUME CONTROL SOLENOID VALVE

 **With CONSULT-II**

1. Turn ignition switch OFF.
2. Reconnect harness connectors disconnected.
3. Start engine.
4. Perform "PURG VOL CONT/V" in "ACTIVE TEST" mode with CONSULT-II. Check that engine speed varies according to the valve opening.

OK or NG

- OK >> GO TO 8.
- NG >> GO TO 7.

ACTIVE TEST	
PURG VOL CONT/V	XXX %
MONITOR	
ENG SPEED	XXX rpm
A/F ALPHA-B1	XX %
A/F ALPHA-B2	XX %

PBIB1678E

7. CHECK EVAP CANISTER PURGE VOLUME CONTROL SOLENOID VALVE

Refer to [EC-417, "Component Inspection"](#) .

OK or NG

- OK >> GO TO 8.
- NG >> Replace EVAP canister purge volume control solenoid valve.

8. CHECK RUBBER TUBE FOR CLOGGING

1. Disconnect rubber tube connected to EVAP canister vent control valve.
2. Check the rubber tube for clogging.

OK or NG

- OK >> GO TO 9.
- NG >> Clean the rubber tube using an air blower.

9. CHECK EVAP CANISTER VENT CONTROL VALVE

Refer to [EC-431, "Component Inspection"](#) .

OK or NG

- OK >> GO TO 10.
- NG >> Replace EVAP canister vent control valve.

DTC P0452 EVAP CONTROL SYSTEM PRESSURE SENSOR

7. CHECK EVAP CONTROL SYSTEM PRESSURE SENSOR INPUT SIGNAL CIRCUIT FOR OPEN AND SHORT

1. Check harness continuity between ECM terminal 32 and EVAP control system pressure sensor terminal 2.
Refer to Wiring Diagram.

Continuity should exist.

2. Also check harness for short to ground and short to power.

OK or NG

- OK >> GO TO 9.
NG >> GO TO 8.

8. DETECT MALFUNCTIONING PART

Check the following.

- Harness connectors B1, M12
- Harness connectors M72, F102
- Harness for open or short between EVAP control system pressure sensor and ECM

>> Repair open circuit or short to ground or short to power in harness or connectors.

9. CHECK EVAP CONTROL SYSTEM PRESSURE SENSOR

Refer to [EC-448, "Component Inspection"](#) .

OK or NG

- OK >> GO TO 10.
NG >> Replace EVAP control system pressure sensor.

10. CHECK INTERMITTENT INCIDENT

Refer to [EC-151, "TROUBLE DIAGNOSIS FOR INTERMITTENT INCIDENT"](#) .

>> **INSPECTION END**

Component Inspection EVAP CONTROL SYSTEM PRESSURE SENSOR

NBS0007K

1. Remove EVAP control system pressure sensor with its harness connector connected from EVAP canister.
Always replace O-ring with a new one.
2. Install a vacuum pump to EVAP control system pressure sensor.
3. Turn ignition switch ON and check output voltage between ECM terminal 32 and ground under the following conditions.

Applied vacuum kPa (mmHg, inHg)	Voltage V
Not applied	1.8 - 4.8
-26.7 (-200, -7.87)	2.1 to 2.5V lower than above value

CAUTION:

- Always calibrate the vacuum pump gauge when using it.
 - Do not apply below -93.3 kPa (-700 mmHg, -27.56 inHg) or pressure over 101.3 kPa (760 mmHg, 29.92 inHg).
4. If NG, replace EVAP control system pressure sensor.

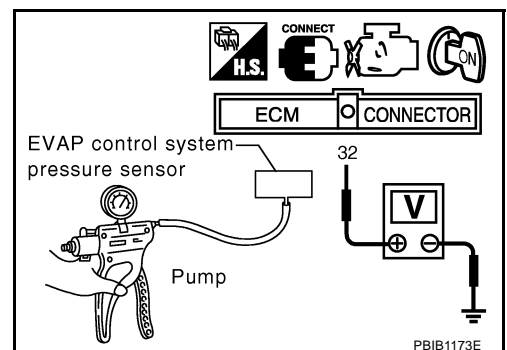

CLICK HERE TO **DOWNLOAD** THE COMPLETE MANUAL

- Thank you very much for reading the preview of the manual.
- You can download the complete manual from: www.heydownloads.com by clicking the link below



- Please note: If there is no response to CLICKING the link, please download this PDF first and then click on it.

CLICK HERE TO **DOWNLOAD** THE COMPLETE MANUAL

DTC P0500 VSS

DTC P0500 VSS

PFP:32702

Description

NBS000UE

NOTE:

- If DTC P0500 is displayed with DTC U1000 or U1001, first perform the trouble diagnosis for DTC U1000, U1001. Refer to [EC-161, "DTC U1000, U1001 CAN COMMUNICATION LINE"](#).
- If DTC P0500 is displayed with DTC U1010, first perform the trouble diagnosis for DTC U0500. Refer to [EC-164, "DTC U1010 CAN COMMUNICATION"](#).

The vehicle speed signal is sent to the combination meter from the VDC/TCS/ABS control unit by CAN communication line. The combination meter then sends the signal to the ECM by CAN communication line.

On Board Diagnosis Logic

NBS000UF

DTC No.	Trouble diagnosis name	DTC detecting condition	Possible cause
P0500 0500	Vehicle speed sensor	The almost 0 km/h (0 MPH) signal from vehicle speed sensor is sent to ECM even when vehicle is being driven.	<ul style="list-style-type: none">● Harness or connectors (The CAN communication line is open or shorted)● Harness or connectors (The vehicle speed signal circuit is open or shorted)● Wheel sensor● Combination meter● VDC/TCS/ABS control unit

FAIL-SAFE MODE

When the malfunction is detected, the ECM enters fail-safe mode.

Detected items	Engine operating condition in fail-safe mode
Vehicle speed sensor	When the fail-safe system for vehicle speed sensor is activated, the cooling fan operates (High) while engine is running.

DTC Confirmation Procedure

NBS000UG

CAUTION:

Always drive vehicle at a safe speed.

NOTE:

If DTC Confirmation Procedure has been previously conducted, always turn ignition switch OFF and wait at least 10 seconds before conducting the next test.

TESTING CONDITION:

Steps 1 and 2 may be conducted with the drive wheels lifted in the shop or by driving the vehicle. If a road test is expected to be easier, it is unnecessary to lift the vehicle.

Ⓜ WITH CONSULT-II

1. Start engine (VDC switch OFF).
2. Read "VHCL SPEED SE" in "DATA MONITOR" mode with CONSULT-II. The vehicle speed on CONSULT-II should exceed 10 km/h (6 MPH) when rotating wheels with suitable gear position.
If NG, go to [EC-482, "Diagnostic Procedure"](#).
If OK, go to following step.
3. Select "DATA MONITOR" mode with CONSULT-II.
4. Warm engine up to normal operating temperature.

DTC P1078 P1084 EVT CONTROL POSITION SENSOR

DTC P1078 P1084 EVT CONTROL POSITION SENSOR

PFP:23731

Component Description

NBS000VG

Exhaust valve timing control position sensor detects the concave groove of the exhaust camshaft rear end.

This sensor signal is used for sensing a position of the exhaust camshaft.

This sensor uses a Hall IC.

Based on the position of the exhaust camshaft, ECM controls exhaust valve timing control magnet retarder to optimize the shut/open timing of exhaust valve for the driving condition.

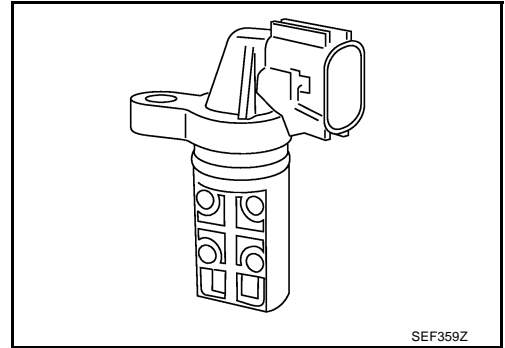

CONSULT-II Reference Value in Data Monitor Mode

NBS000VH

Specification data are reference values.

MONITOR ITEM	CONDITION		SPECIFICATION
EXH/V TIM B1 EXH/V TIM B2	<ul style="list-style-type: none"> ● Engine: After warming up ● Shift lever: Neutral 	Idle	-5° - 5°C
	<ul style="list-style-type: none"> ● Air conditioner switch: OFF ● No load 	Engine speed: 2,000 rpm	Approx. 0° - 30°C

On Board Diagnosis Logic

NBS000VI

DTC No.	Trouble diagnosis name	DTC detecting condition	Possible cause
P1078 1078 (Bank 1)	Exhaust valve timing control position sensor circuit	An excessively high or low voltage from the sensor is sent to ECM.	<ul style="list-style-type: none"> ● Harness or connectors (Exhaust valve timing control position sensor circuit is open or shorted) ● Exhaust valve timing control position sensor ● Crankshaft position sensor (POS) ● Camshaft position sensor (PHASE) ● Accumulation of debris to the signal pick-up portion of the camshaft
P1084 1084 (Bank 2)			

DTC Confirmation Procedure

NBS000VJ

NOTE:

If DTC Confirmation Procedure has been previously conducted, always turn ignition switch OFF and wait at least 10 seconds before conducting the next test.

WITH CONSULT-II

1. Turn ignition switch ON.
2. Select "DATA MONITOR" mode with CONSULT-II.
3. Start engine and let it idle for 10 seconds.
4. If 1st trip DTC is detected, go to [EC-516, "Diagnostic Procedure"](#)

DATA MONITOR	
MONITOR	NO DTC
ENG SPEED	XXX rpm

SEF058Y

WITH GST

Follow the procedure WITH CONSULT-II above.

DTC P1564 ASCD STEERING SWITCH

Specification data are reference values and are measured between each terminal and ground.

CAUTION:

Do not use ECM ground terminals when measuring input/output voltage. Doing so may result in damage to the ECM's transistor. Use a ground other than ECM terminals, such as the ground.

TER-MINAL NO.	WIRE COLOR	ITEM	CONDITION	DATA (DC Voltage)
67	B/W	Sensor ground	[Engine is running] <ul style="list-style-type: none"> ● Warm-up condition ● Idle speed 	Approximately 0V
99	G/Y	ASCD steering switch	[Ignition switch: ON] <ul style="list-style-type: none"> ● ASCD steering switch: OFF 	Approximately 4V
			[Ignition switch: ON] <ul style="list-style-type: none"> ● MAIN switch: Pressed 	Approximately 0V
			[Ignition switch: ON] <ul style="list-style-type: none"> ● CANCEL switch: Pressed 	Approximately 1V
			[Ignition switch: ON] <ul style="list-style-type: none"> ● RESUME/ACCELERATE switch: Pressed 	Approximately 3V
			[Ignition switch: ON] <ul style="list-style-type: none"> ● SET/COAST switch: Pressed 	Approximately 2V

DTC P2100, P2103 THROTTLE CONTROL MOTOR RELAY

Specification data are reference values and are measured between each terminal and ground.
Pulse signal is measured by CONSULT-II.

CAUTION:

Do not use ECM ground terminals when measuring input/output voltage. Doing so may result in damage to the ECM's transistor. Use a ground other than ECM terminals, such as the ground.

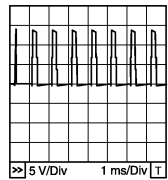
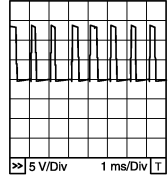
TER-MINAL NO.	WIRE COLOR	ITEM	CONDITION	DATA (DC Voltage)
3	W/R	Throttle control motor relay power supply	[Ignition switch: ON]	BATTERY VOLTAGE (11 - 14V)
4	BR	Throttle control motor (Close)	[Ignition switch: ON] <ul style="list-style-type: none"> ● Engine stopped ● Shift lever: D (A/T) or 1st (M/T) ● Accelerator pedal: Fully released 	0 - 14V★  <small>PBIB1104E</small>
5	G	Throttle control motor (Open)	[Ignition switch: ON] <ul style="list-style-type: none"> ● Engine stopped ● Shift lever: D (A/T) or 1st (M/T) ● Accelerator pedal: Fully depressed 	0 - 14V★  <small>PBIB1105E</small>
104	G/W	Throttle control motor relay	[Ignition switch: OFF]	BATTERY VOLTAGE (11 - 14V)
			[Ignition switch: ON]	0 - 1.0V

★: Average voltage for pulse signal (Actual pulse signal can be confirmed by oscilloscope.)

Diagnostic Procedure

NBS000WC

1. CHECK THROTTLE CONTROL MOTOR RELAY POWER SUPPLY CIRCUIT-I

1. Turn ignition switch OFF.
2. Check voltage between ECM terminal 104 and ground with CONSULT-II or tester.

Voltage: Battery voltage

OK or NG

- OK >> GO TO 5.
NG >> GO TO 2.

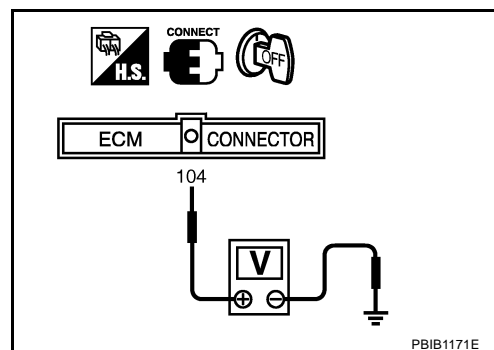

DTC P2135 TP SENSOR

Wiring Diagram

NBS00116

EC-TPS3-01

— : DETECTABLE LINE FOR DTC
— : NON-DETECTABLE LINE FOR DTC

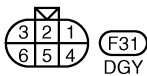
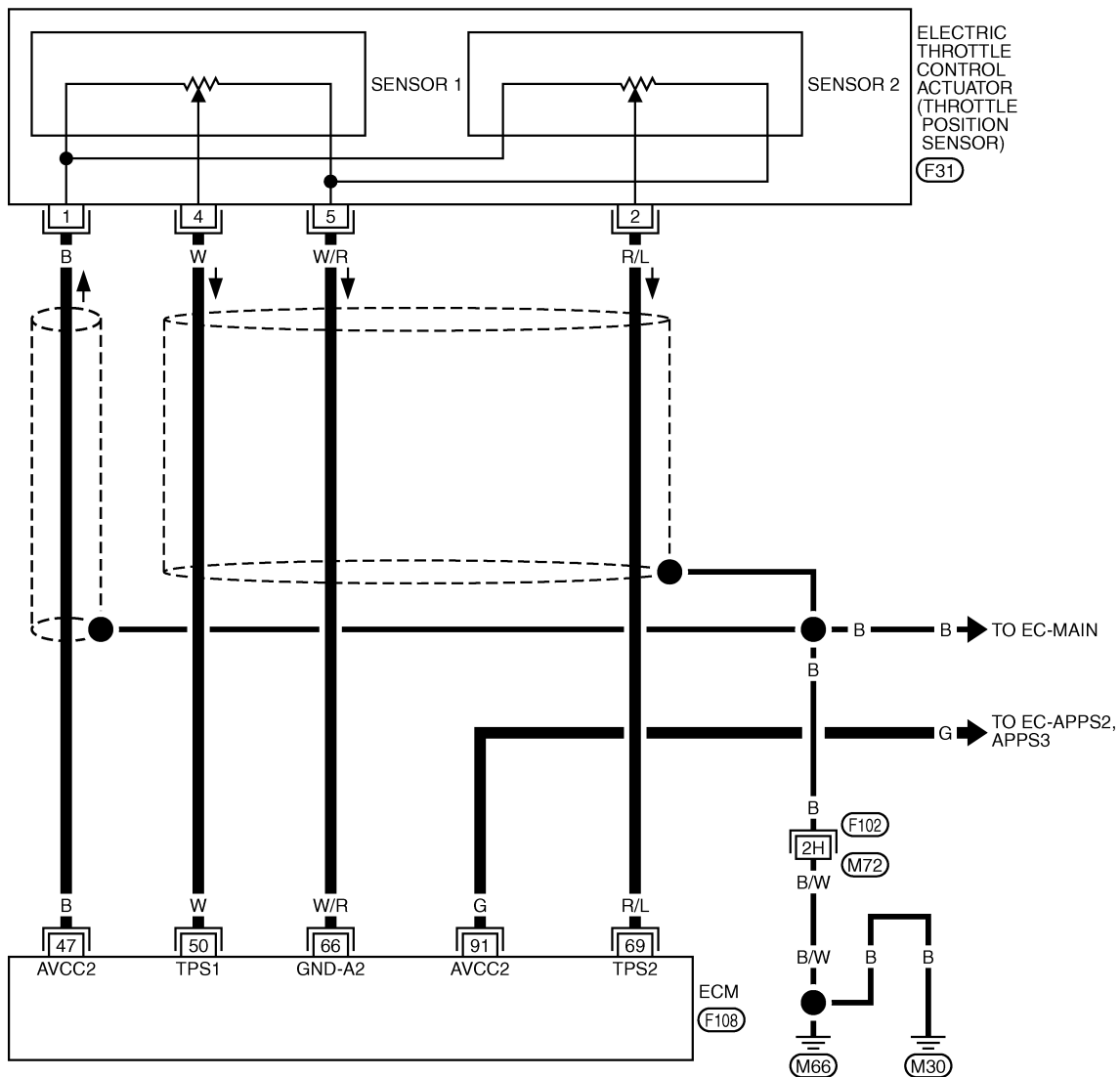

REFER TO THE FOLLOWING.
 (F102) -SUPER MULTIPLE JUNCTION (SMJ)

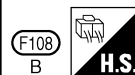
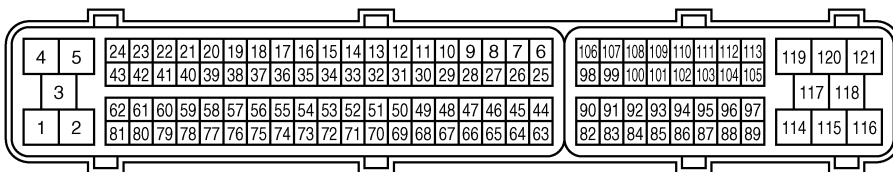

TBWM0829E

ASCD BRAKE SWITCH

11. DETECT MALFUNCTIONING PART

Check the following.

- Harness connectors E108, M15
- Harness connectors M72, F102
- Harness for open or short between ECM and stop lamp switch

>> Repair open circuit or short to ground or short to power in harness or connectors.

12. CHECK STOP LAMP SWITCH

Refer to [EC-646, "Component Inspection"](#)

OK or NG

OK >> GO TO 13.

NG >> Replace stop lamp switch.

13. CHECK INTERMITTENT INCIDENT

Refer to [EC-151, "TROUBLE DIAGNOSIS FOR INTERMITTENT INCIDENT"](#) .

>> **INSPECTION END**

IGNITION SIGNAL

3. CHECK OVERALL FUNCTION

⊗ Without CONSULT-II

1. Let engine idle.
2. Read the voltage signal between ECM terminals 60, 61, 62, 79, 80, 81 and ground with an oscilloscope.
3. Verify that the oscilloscope screen shows the signal wave as shown below.

NOTE:

The pulse cycle changes depending on rpm at idle.

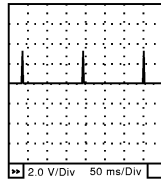

SEC986C

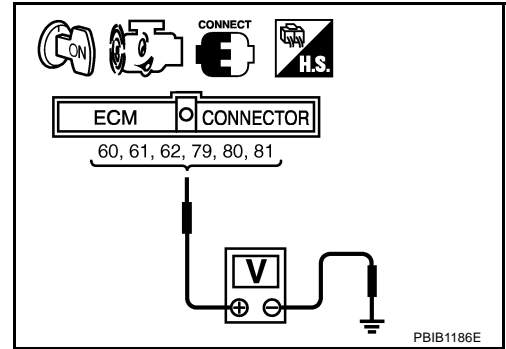

OK or NG

- OK >> **INSPECTION END**
NG >> GO TO 10.

4. CHECK IGNITION COIL POWER SUPPLY CIRCUIT-I

1. Turn ignition switch OFF, wait at least 10 seconds and then turn ON.
2. Check voltage between ECM terminals 119, 120 and ground with CONSULT-II or tester.

Voltage: Battery voltage

OK or NG

- OK >> GO TO 5.
NG >> Go to [EC-152. "POWER SUPPLY AND GROUND CIRCUIT"](#).

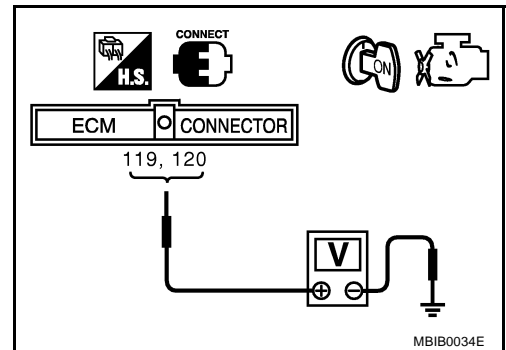

FRONT GRILLE

FRONT GRILLE

PFP:62310

Removal and Installation

NIS000GO

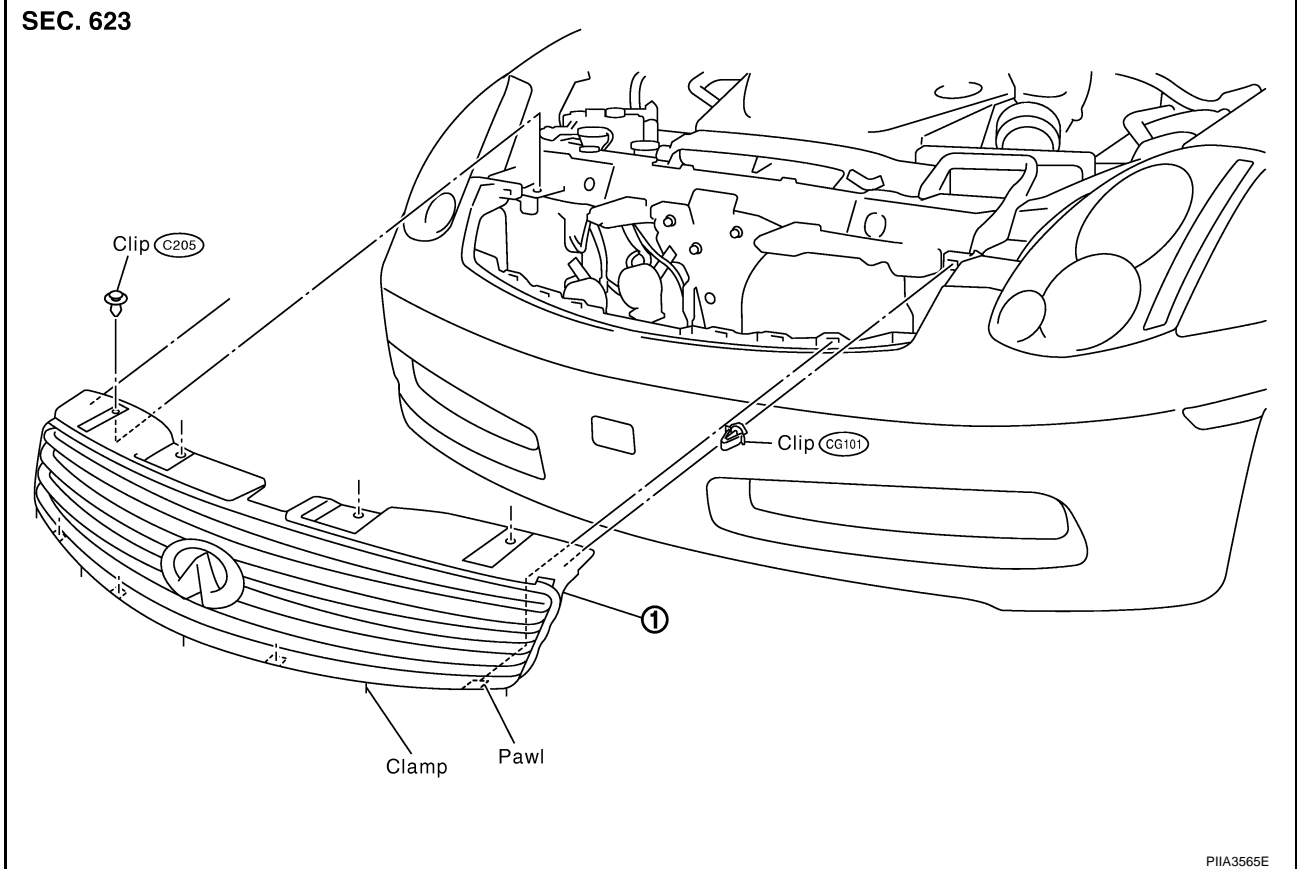

1. Front grille



REMOVAL

1. Apply protection tape around outer circumference of front grille (bumper fascia side).
2. Remove clips on upper side of grille.
3. Pull down tips of four turn fasteners from rear side of grille.
4. Disconnect turn fasteners then pull out grille.

INSTALLATION

Install in the reverse order of removal.

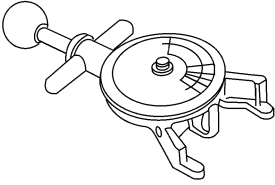
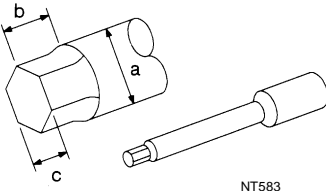
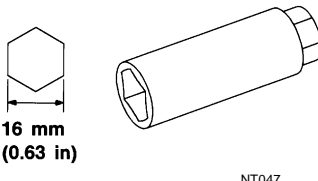
PREPARATION

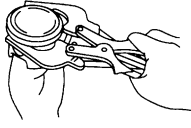
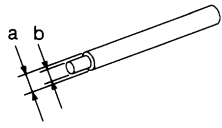
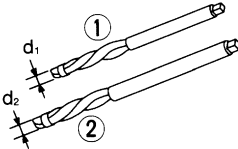
(Kent-Moore No.) Tool name	Description
(BT3373-F) Belt tension gauge <div style="text-align: center;">  <p>AMA126</p> </div>	Checking drive belt tension
(J24239-01) Cylinder head bolt wrench <div style="text-align: center;">  <p>NT583</p> </div>	Loosening and tightening cylinder head bolt, and used with angle wrench [SST: KV10112100 (BT8653-A)] a: 13 (0.51) dia. b: 12 (0.47) c: 10 (0.39) Unit: mm (in)
(—) Spark plug wrench <div style="text-align: center;">  <p>NT047</p> </div>	Removing and installing spark plug
(—) Valve seat cutter set <div style="text-align: center;">  <p>NT048</p> </div>	Finishing valve seat dimensions
(—) Piston ring expander <div style="text-align: center;">  <p>NT030</p> </div>	Removing and installing piston ring
(—) Valve guide drift <div style="text-align: center;">  <p>NT015</p> </div>	Removing and installing valve guide Intake & Exhaust: a = 9.5 mm (0.374 in) dia. b = 5.5 mm (0.217 in) dia.
(—) Valve guide reamer <div style="text-align: center;">  <p>NT016</p> </div>	Reaming valve guide with (1) or hole for oversize valve guide with (2) Intake & Exhaust: d1 = 6.0 mm (0.236 in) dia. d2 = 10.2 mm (0.402 in) dia.

FUEL INJECTOR AND FUEL TUBE

- Tighten mounting bolts in two steps in numerical order as shown in the figure.

- 🔧 **1st step**
: 9.3 - 10.8 N·m (0.95 - 1.1 kg·m, 6.9 - 7.9 ft·lb)
- 🔧 **2nd step**
: 20.6 - 26.5 N·m (2.1 - 2.7 kg·m, 16 - 19 ft·lb)

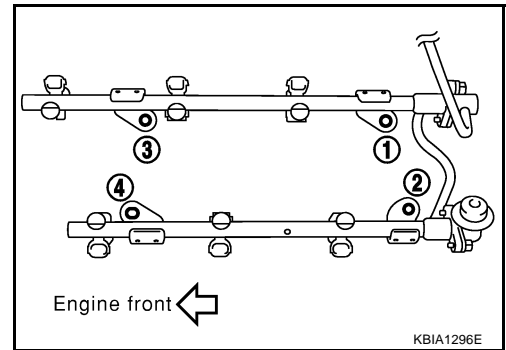

6. Connect fuel injector harness connector.
7. Install intake manifold collectors (upper and lower). Refer to [EM-18, "INTAKE MANIFOLD COLLECTOR"](#).
8. Install fuel sub-tube on rear end of intake manifold collector (lower).
9. Connect fuel feed hose (with damper).
 - Handling procedure of O-ring is the same as that of fuel damper and fuel sub-tube.
 - Insert fuel damper straight into fuel sub-tube.
 - Tighten mounting bolts evenly in turn.
 - After tightening mounting bolts, make sure that there is no gap between flange and fuel sub-tube.
10. Connect quick connector between fuel feed hose (with damper) and centralized under-floor piping connection as follows:

- a. Check the connection for damage and foreign materials.
- b. Align the connector with tube, then insert the connector straight into the tube until a click is heard.
- c. After connecting quick connector, use the following method to make sure it is full connected.
 - Visually confirm that the two retainer tabs are connected to the connector.
 - Pull the tube and the connector to make sure they are securely connected.

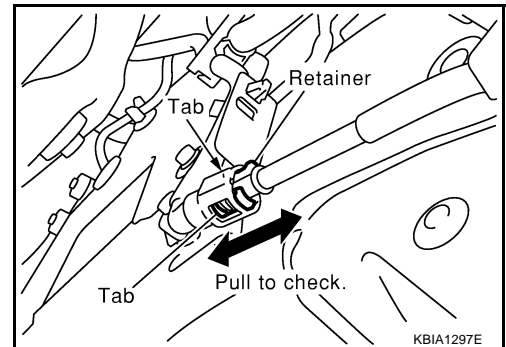

- d. Install quick connector cap to quick connector connection.
 - Install quick connector cap with arrow on surface facing in direction of quick connector (fuel feed hose side).

CAUTION:
If cap cannot be installed smoothly, quick connector may have not been installed correctly. Check connection again.

- e. Secure fuel feed hose (with damper) to clamp.

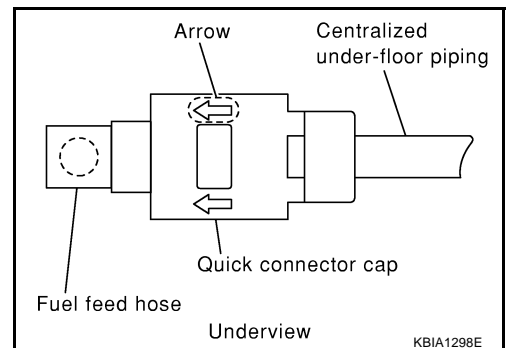

11. Install in the reverse order of removal after this step.

INSPECTION AFTER INSTALLATION

Check on Fuel Leakage

1. Turn ignition switch "ON" (with engine stopped). With fuel pressure applied to fuel piping, check for fuel leakage at connection points.
2. Start engine. With engine speed increased, check again for fuel leakage at connection points.

NOTE:
Use mirrors for checking at points out of clear sight.

TIMING CHAIN

- d. Tighten camshaft sprocket mounting bolts.
- Secure camshaft using wrench at the hexagonal portion to tighten mounting bolts.

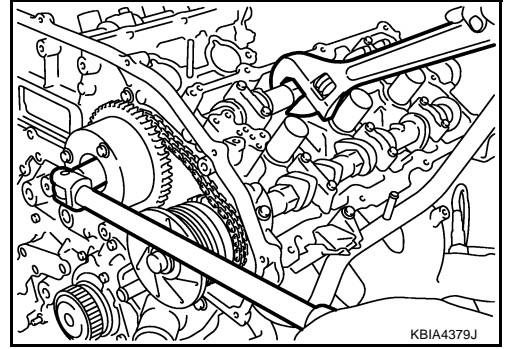

- e. Pull stopper pins out from timing chain tensioners (secondary).

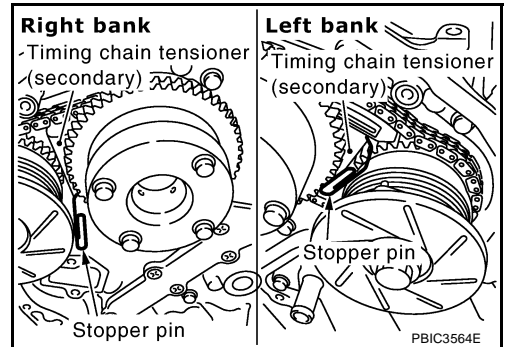

6. Install tension guide.
7. Install timing chain (primary) as follows:
- a. Install crankshaft sprocket.
- Make sure the mating marks on crankshaft sprocket face the front of engine.

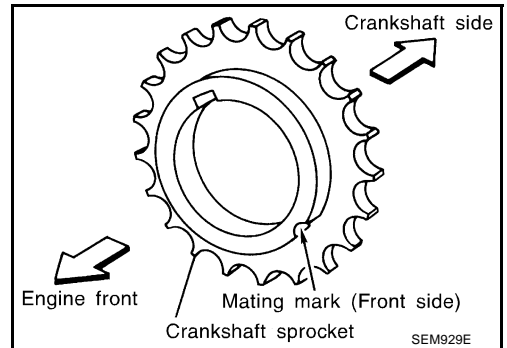

- b. Install timing chain (primary).

CAMSHAFT

- Install camshaft with dowel pin attached to its front end face on the exhaust side.

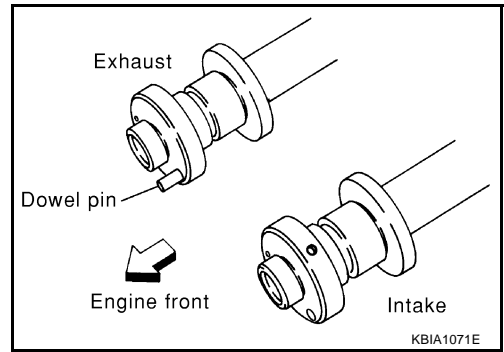

- Follow your identification marks made during removal, or follow the identification marks that are present on new camshafts for proper placement and direction.

Bank	INT/EXH	Dowel pin	Paint marks		Identification mark
			M1	M2	
RH	INT	No	Pink	No	RE
	EXH	Yes	No	Orange	RE
LH	INT	No	Pink	No	LH
	EXH	Yes	No	Orange	LH

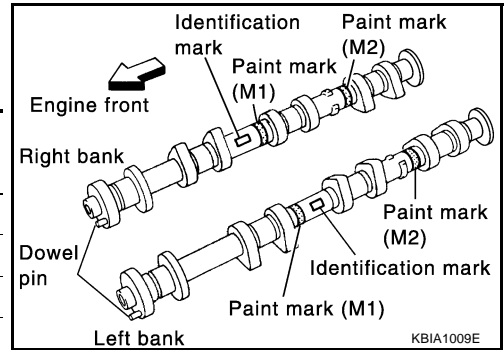

- Install camshaft so that dowel pin hole and dowel pin on front end face are positioned as shown in the figure. (No. 1 cylinder TDC on its compression stroke)

NOTE:

- Large and small pin holes are located on front end face of camshaft (INT), at intervals of 180 degrees. Face small dia. side pin hole upward (in cylinder head upper face direction).
- Though camshaft does not stop at the portion as shown in the figure, for the placement of cam nose, it is generally accepted camshaft is placed for the same direction of the figure.

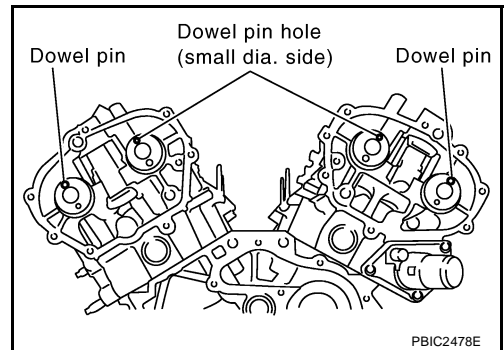

4. Install camshafts. (M/T models)

- The distinguishing between intake and exhaust depends on the difference of the shape (the number of the notch) of the signal plate area on rear end of camshaft.

Intake : 6 notches

Exhaust : 3 notches

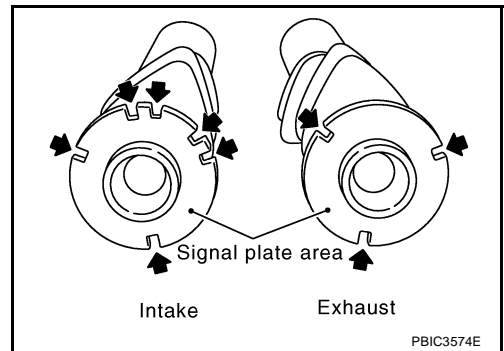

CYLINDER BLOCK

- | | | |
|--------------------------------------|--------------------------------------|--------------------------------|
| 1. Reinforcement plate | 2. Drive plate (A/T models) | 3. Cover |
| 4. Gasket | 5. Knock sensor | 6. Cylinder block |
| 7. Rear oil seal retainer | 8. Oil jet | 9. Thrust bearing |
| 10. Pilot converter (A/T models) | 11. Pilot bushing (M/T models) | 12. Main bearing |
| 13. Crankshaft | 14. Crankshaft key | 15. Main bearing cap |
| 16. Main bearing cap bolt | 17. Main bearing beam | 18. Baffle plate |
| 19. Connecting rod bolt (A/T models) | 20. Connecting rod bolt (M/T models) | 21. Connecting rod bearing cap |
| 22. Connecting rod bearing | 23. Connecting rod | 24. Snap ring |
| 25. Piston pin | 26. Piston | 27. Oil ring |
| 28. Second ring | 29. Top ring | 30. Flywheel (M/T models) |

For Canada SEC. 110

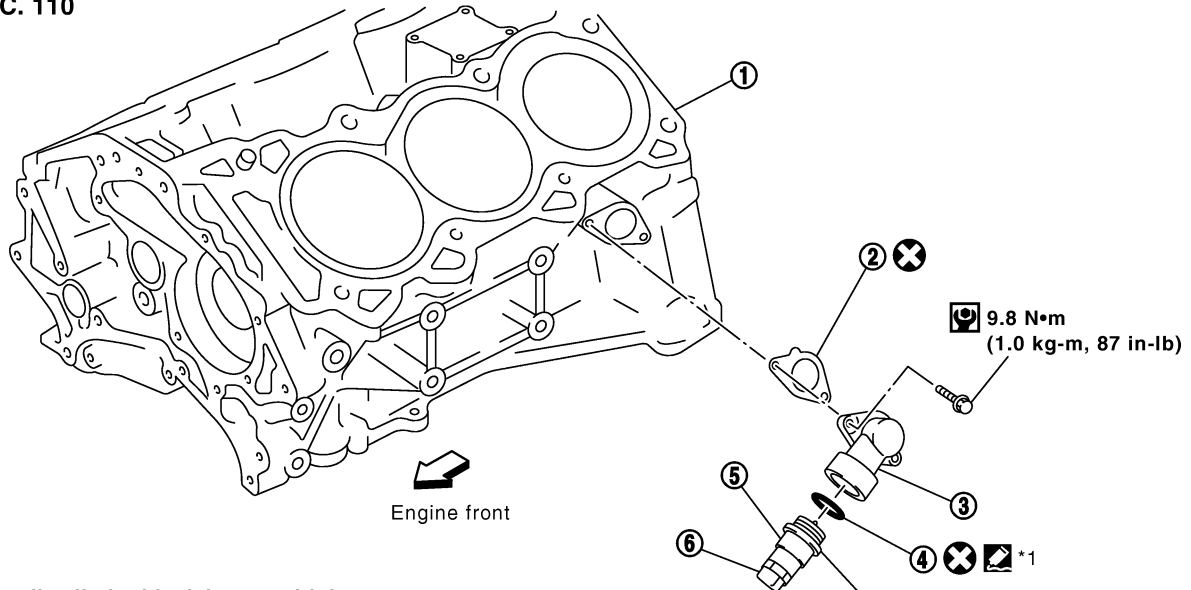

- Install cylinder block heater with heater part downward as shown in the figure.
- Remove liquid gasket completely after removing cylinder block heater.

: Apply Anaerobic Liquid Gasket or equivalent.
Refer to GI section.

*1 Sealing point: Front and reverse side.

: Always replace after every disassembly.

PBIC2614E

- | | | |
|-------------------|--------------------------|----------------------------|
| 1. Cylinder block | 2. Gasket | 3. Water connector |
| 4. Gasket | 5. Cylinder block heater | 6. Connector protector cap |

Disassembly and Assembly DISASSEMBLY

NBS002V6

1. Remove engine assembly from vehicle, and separate suspension member and transmission from engine. Refer to [EM-131, "ENGINE ASSEMBLY"](#).
2. Remove engine mounting brackets. Refer to [EM-131, "ENGINE ASSEMBLY"](#).
3. Remove exhaust manifold (right bank). Refer to [EM-25, "EXHAUST MANIFOLD AND THREE WAY CATALYST"](#).

SERVICE DATA AND SPECIFICATIONS (SDS)

Available Valve Lifter

Unit: mm (in)

Identification (stamped) mark		Thickness
Intake	Exhaust	
788U	788R	7.88 (0.3102)
790U	790R	7.90 (0.3110)
792U	792R	7.92 (0.3118)
794U	794R	7.94 (0.3126)
796U	796R	7.96 (0.3134)
798U	798R	7.98 (0.3142)
800U	800R	8.00 (0.3150)
802U	802R	8.02 (0.3157)
804U	804R	8.04 (0.3165)
806U	806R	8.06 (0.3173)
808U	808R	8.08 (0.3181)
810U	810R	8.10 (0.3189)
812U	812R	8.12 (0.3197)
814U	814R	8.14 (0.3205)
816U	816R	8.16 (0.3213)
818U	818R	8.18 (0.3220)
820U	820R	8.20 (0.3228)
822U	822R	8.22 (0.3236)
824U	824R	8.24 (0.3244)
826U	826R	8.26 (0.3252)
828U	828R	8.28 (0.3260)
830U	830R	8.30 (0.3268)
832U	832R	8.32 (0.3276)
834U	834R	8.34 (0.3283)
836U	836R	8.36 (0.3291)
838U	838R	8.38 (0.3299)
840U	840R	8.40 (0.3307)

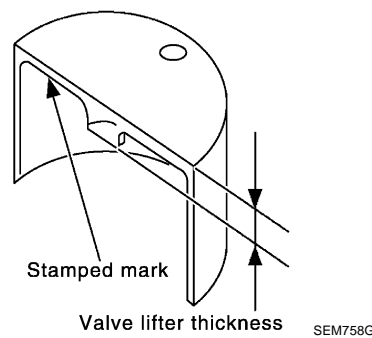

FUEL LEVEL SENSOR UNIT, FUEL FILTER AND FUEL PUMP ASSEMBLY

3. After fixing tabs are disengaged, slide fuel level sensor unit out in direction shown by the arrow.

CAUTION:

Do not disassemble fuel filter and fuel pump assembly.

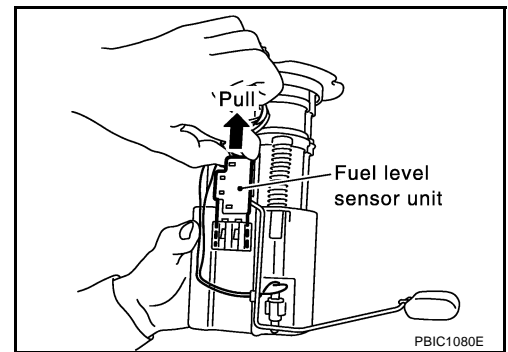

ASSEMBLY

1. Check for damage of fuel level sensor unit installation position on the side of fuel filter and fuel pump assembly.
2. Slide fuel level sensor unit until it aligns to installation groove, then insert it until stop.
 - After inserting, apply force in reverse direction (removal direction) to ensure it cannot be pulled out.
3. Connect harness connector.
 - Securely insert harness connector until it stops.

PRECAUTIONS

- After installing plate clamps, apply force to them in the direction of the arrow, tightening rubber hose equally all around.

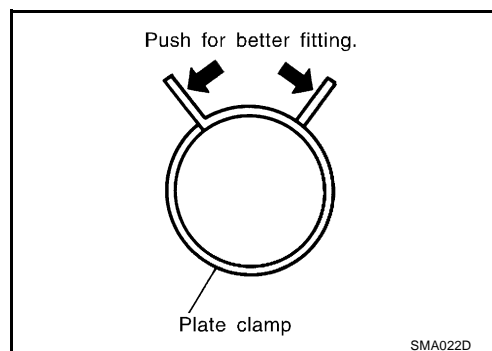

Precautions for Engine Oils

NAS0001H

Prolonged and repeated contact with used engine oil may cause skin cancer. Try to avoid direct skin contact with used oil.

If skin contact is made, wash thoroughly with soap or hand cleaner as soon as possible.

HEALTH PROTECTION PRECAUTIONS

- Avoid prolonged and repeated contact with oils, particularly used engine oils.
- Wear protective clothing, including impervious gloves where practicable.
- Do not put oily rags in pockets.
- Avoid contaminating clothes, particularly underpants, with oil.
- Heavily soiled clothing and oil-impregnated footwear should not be worn. Overalls must be cleaned regularly.
- First aid treatment should be obtained immediately for open cuts and wounds.
- Use barrier creams, applying them before each work period, to help the removal of oil from the skin.
- Wash with soap and water to ensure all oil is removed (skin cleansers and nail brushes will help). Preparations containing lanolin replace the natural skin oils which have been removed.
- Do not use gasoline, kerosene, diesel fuel, gas oil, thinners or solvents for cleaning skin.
- If skin disorders develop, obtain medical advice without delay.
- Where practical, degrease components prior to handling.
- Where there is a risk of eye contact, eye protection should be worn, for example, chemical goggles or face shields; in addition an eye wash facility should be provided.

Precautions for Air Conditioning

NAS0001I

Use an approved refrigerant recovery unit any time the air conditioning system must be discharged. Refer to ATC/MTC section "HFC-134a (R-134a) Service Procedure", "REFRIGERANT LINES" for specific instructions.

LIFTING POINT

LIFTING POINT

PFP:00000

Commercial Service Tools

NAS00020

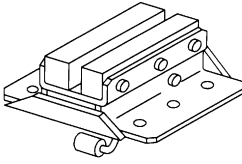
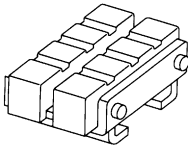
Tool name	Description
Board on attachment	 <p>S-NT001</p>
Safety stand attachment	 <p>S-NT002</p>

CAUTION:

- Every time the vehicle is lifted up, maintain the complete vehicle curb condition.
- Since the vehicle's center of gravity changes when removing main parts on the front side (engine, transmission, suspension etc.), support a jack up point on the rear side garage jack with a mission jack or equivalent.
- Since the vehicle's center of gravity changes when removing main parts on the rear side (rear axle, suspension, etc.), support a jack up point on the front side garage jack with a mission jack or equivalent.
- Be careful not to smash or do not do anything that would affect piping parts.

Garage Jack and Safety Stand

NAS00021

WARNING:

- Park the vehicle on a level surface when using the jack. Make sure to avoid damaging pipes, tubes, etc. under the vehicle.
- Never get under the vehicle while it is supported only by the jack. Always use safety stands when you have to get under the vehicle.

POWER WINDOW SYSTEM

NIS000E8

System Description

Power is supplied at all time

- through 50A fusible link (letter **F** , located in the fuse and fusible link box)
- to BCM terminal 55
- through 10A fuse [No. 18, located in the fuse block (J/B)]
- to BCM terminal 42
- through BCM terminal 54
- to power window main switch terminal 1
- to power window sub-switch terminal 10.

With ignition switch in ON or START position, power is supplied

- through 10A fuse [No. 1, located in the fuse block (J/B)]
- to BCM terminal 38
- through BCM terminal 53
- to power window main switch terminal 10

Ground supplied

- to BCM terminal 52
- through body grounds M30 and M66.
- to power window main switch terminal 15
- through body grounds M30 and M66.
- to power window sub-switch terminal 11
- through body grounds M30 and M66.

MANUAL OPERATION

Driver Side Door

WINDOW UP

When the driver side window switch in the power window main switch is pressed in the up position, Power is supplied

- through power window main switch terminal 8.
- to driver side power window motor terminal 2

Ground is supplied

- to driver side power window motor terminal 1
- through power window main switch terminal 11.

Then, the motor raises the window until the switch is released.

WINDOW DOWN

When the driver side window switch in the power window main switch is pressed in the down position Power is supplied

- through power window main switch terminal 11.
- to driver side power window motor terminal 1

Ground is supplied

- to driver side power window motor terminal 2
- through power window main switch terminal 8.

Then, the motor lowers the window until the switch is released.

POWER WINDOW SYSTEM

NIS000EU

Check Door Key Cylinder Switch

1. CHECK DOOR KEY CYLINDER SWITCH INPUT SIGNAL

With CONSULT-II

Check door key cylinder switch ("KEY CYL LK-SW", "KEY CYL UN-SW") in "DATA MONITOR" mode for "POWER DOOR LOCK SYSTEM" with CONSULT-II. Refer to [BL-36](#)

Monitor item	Condition	
KEY CYL LK-SW	Neutral / Unlock	: OFF
	Lock	: ON
KEY CYL UN-SW	Neutral / Lock	: OFF
	Unlock	: ON

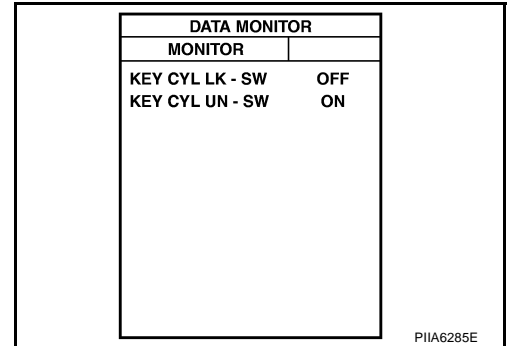

Without CONSULT-II

Check voltage between power window main switch (door lock and unlock switch) connector and ground.

Connector	Terminals (Wire color)		Key position	Voltage (V) (Approx.)
	(+)	(-)		
D7	6 (Y)	Ground	Neutral/Unlock	5
			Lock	0
	7 (SB)		Neutral/Lock	5
			Unlock	0

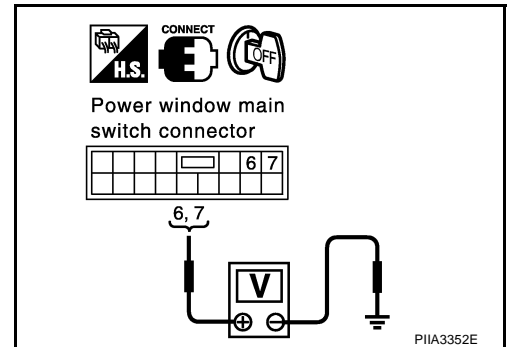

OK or NG

- OK >> Door key cylinder switch is OK.
- NG >> GO TO 2.

2. CHECK DOOR KEY CYLINDER SWITCH CIRCUIT

- Turn ignition switch OFF.
- Disconnect power window main switch (door lock and unlock switch) and door key cylinder switch connector.
- Check continuity between power window main switch (door lock and unlock switch) connector D7 terminal 6, 7 and door key cylinder switch connector D15 terminals 1, 6.

- 6 (Y) – 1 (Y) : Continuity should exist.**
- 7 (SB) – 6 (SB) : Continuity should exist.**

OK or NG

- OK >> GO TO 3.
- NG >> Repair or replace harness.

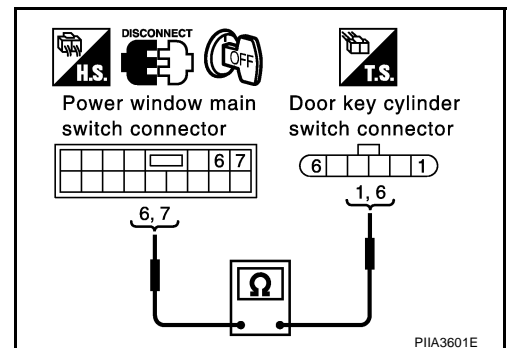

DOOR MIRROR

NIS000FM

Disassembly and Assembly

DISASSEMBLY

1. Place the mirror body with mirror glass facing upward.
2. Put a strip of protective tape on mirror body.
3. As shown in the figure insert a small slotted screwdriver into the recess between mirror base (mirror holder) and mirror holder bracket and push up pawls to remove mirror holder lower half side.

NOTE:

When pushing up pawls, do not attempt to use 1 recess only, be sure to push up with both recesses. Insert screwdriver into recesses, and push up while rotating (twist) to make work easier.

4. Remove terminals of mirror heater attachment.
5. Lightly lift up lower side of mirror surface, and detach pawls of upper side as if pulling it out. Remove mirror surface from mirror body.

NOTE:

Be certain not to allow grease on sealing agent in center of mirror body assembly (actuator) or back side of mirror surface (mirror holder).

ASSEMBLY

1. Place mirror holder bracket and mirror body assembly (actuator) in a horizontal position.
2. Connect terminals of heater installed mirror.
3. Fit the upper pawls on the mirror face onto the mirror holder bracket first, then press the lower side of mirror face until a click sound is heard to engage the lower pawls.

NOTE:

After installation, visually check that lower pawls are securely engaged from the bottom of mirror face.

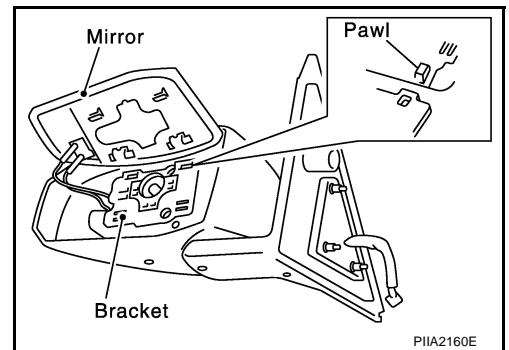
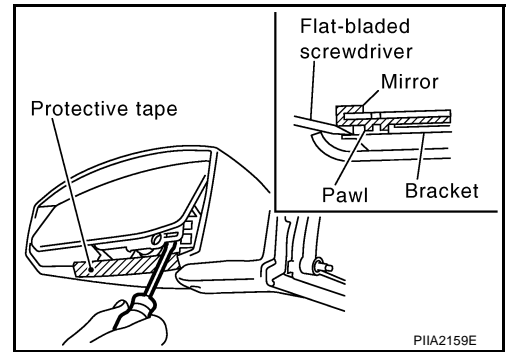

PRECAUTIONS

PF0:00001

Precautions When Using CONSULT-II

NKS00410

Use CONSULT-II CONVERTER when connecting CONSULT-II to data link connector.

CAUTION:

CAN communication does not function properly if CONSULT-II is used without connecting CONSULT-II CONVERTER.

Precautions for Trouble Diagnosis

NKS00410

CAUTION:

- Never apply 7.0 V or more to the measurement terminal.
- Use a tester with open terminal voltage of 7.0 V or less.
- Turn the ignition switch OFF and disconnect the battery cable from the negative terminal when checking the harness.

Precautions for Harness Repair

NKS0041P

- Solder the repaired area and wrap tape around the soldered area.

NOTE:

A fray of twisted lines must be within 110 mm (4.33 in).

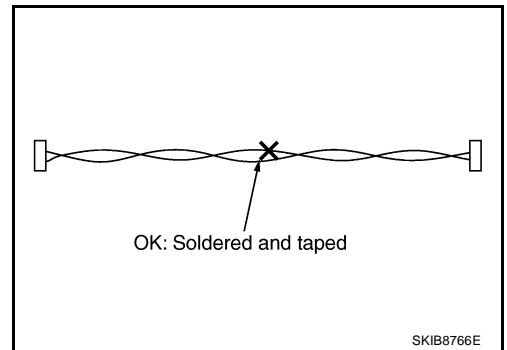

- Bypass connection is never allowed at the repaired area.

NOTE:

Bypass connection may cause CAN communication error. The spliced wire becomes separated and the characteristics of twisted line are lost.

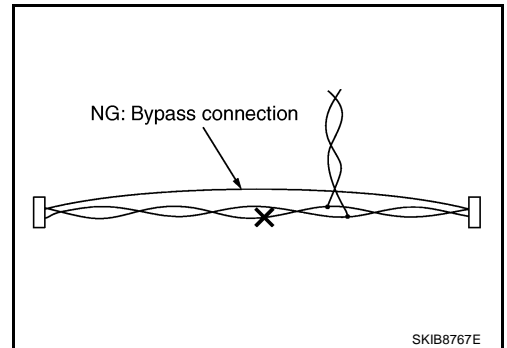

- Replace the applicable harness as an assembly if error is detected on the shield lines of CAN communication line.

A
B
C
D
E
F
G
H
I
J
LAN
L
M

TROUBLE DIAGNOSES WORK FLOW

[CAN FUNDAMENTAL]

3. CAN DIAG SUPPORT MNTR (without PAST): Check the CAN DIAG SUPPORT MNTR (without PAST) of units indicating "U1000" or "U1001" on SELF-DIAG RESULTS. Draw a line on the diagnosis sheet to indicate the possible error circuit.

NOTE:

- While an error occurred in the past according to SELF-DIAG RESULTS, it is unclear which signal is not received. Assume that errors were detected from all reception items.
 - Draw a single line among the unit and all reception items. (Work flow differs from CAN DIAG SUPPORT MNTR (with PAST).)
- a. Reception item of "EPS": Assume that the unit could not receive the signals from ECM, ABS, and M&A. Draw a line among EPS, ECM, ABS, and M&A (line 3-a in the figure).
- b. Reception item of "ABS": Assume that the unit could not receive the signal from ECM. Draw a line between ABS and ECM (line 3-b in the figure).

(Example)

SYSTEM	EPS	PRSENT
DATE		
P/#		
TRANSMIT DIAG		OK
ECM		OK
VDC/TCS/ABS		OK
METER/M&A		OK

SYSTEM	ABS	PRSENT
DATE		
P/#		
INITIAL DIAG		OK
TRANSMIT DIAG		OK
ECM		OK

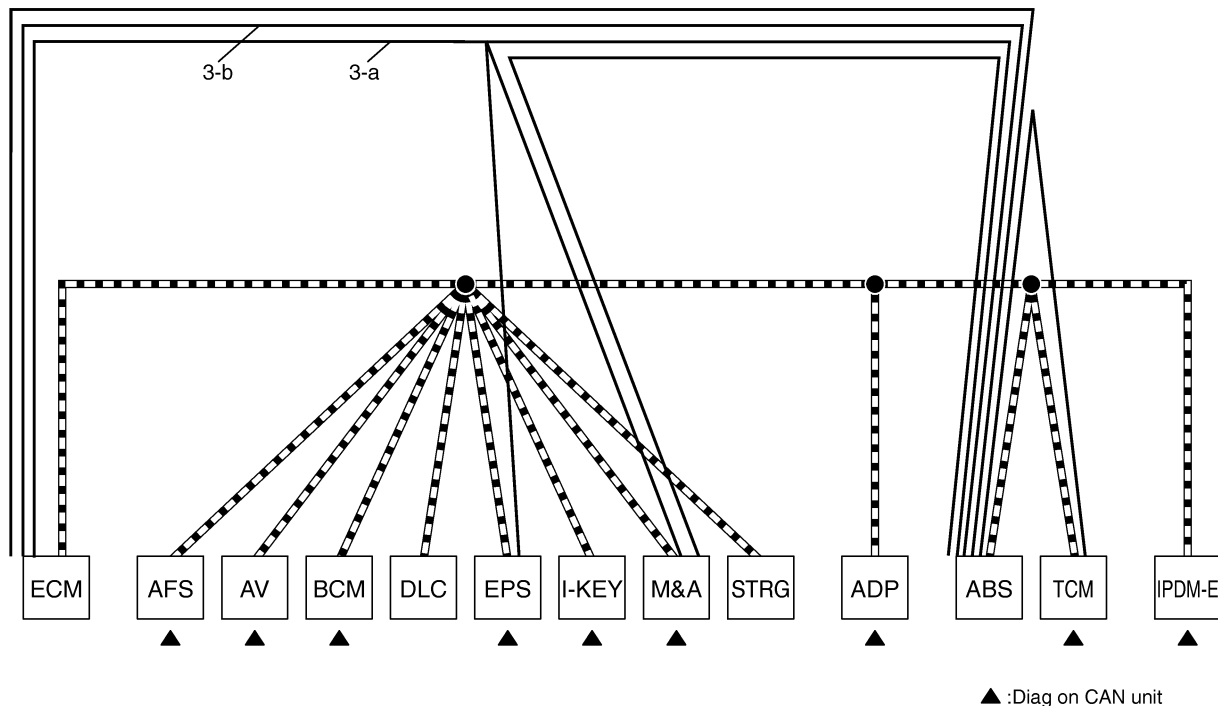

SKIB8733E

A
B
C
D
E
F
G
H
I
J
LAN
L
M

TROUBLE DIAGNOSIS

[CAN]

Malfunction Area Chart

NKS00419

MAIN LINE

Malfunction Area	Reference
Main line between TCM and Intelligent Key unit	LAN-68. "Main Line Between TCM and Intelligent Key Unit"
Main line between VDC/TCS/ABS control unit and data link connector	LAN-69. "Main Line Between VDC/TCS/ABS Control Unit and Data Link Connector"
Main line between data link connector and driver seat control unit	LAN-69. "Main Line Between Data Link Connector and Driver Seat Control Unit"

BRANCH LINE

Malfunction Area	Reference
ECM branch line circuit	LAN-70. "ECM Branch Line Circuit"
TCM branch line circuit	LAN-71. "TCM Branch Line Circuit"
VDC/TCS/ABS control unit branch line circuit	LAN-71. "VDC/TCS/ABS Control Unit Branch Line Circuit"
Intelligent Key unit branch line circuit	LAN-72. "Intelligent Key Unit Branch Line Circuit"
BCM branch line circuit	LAN-73. "BCM Branch Line Circuit"
Data link connector branch line circuit	LAN-73. "Data Link Connector Branch Line Circuit"
Combination meter branch line circuit	LAN-74. "Combination Meter Branch Line Circuit"
Steering angle sensor branch line circuit	LAN-75. "Steering Angle Sensor Branch Line Circuit"
Driver seat control unit branch line circuit	LAN-75. "Driver Seat Control Unit Branch Line Circuit"
RAS control unit branch line circuit	LAN-76. "RAS Control Unit Branch Line Circuit"
IPDM E/R branch line circuit	LAN-77. "IPDM E/R Branch Line Circuit"

SHORT CIRCUIT

Malfunction Area	Reference
CAN communication circuit	LAN-77. "CAN Communication Circuit"

A
B
C
D
E
F
G
H
I
J

LAN

L
M

HEADLAMP - XENON TYPE -

DATA MONITOR

Operation Procedure

1. Touch "DATA MONITOR" on "SELECT DIAG MODE" screen.
2. Touch "ALL SIGNALS", "MAIN SIGNALS" or "SELECTION FROM MENU" on "SELECT MONITOR ITEM" screen.

ALL SIGNALS	Monitors all items.
MAIN SIGNALS	Monitor the predetermined item.
SELECTION FROM MENU	Selects items and monitors them.

3. When "SELECTION FROM MENU" is selected, touch individual items to be monitored. In "ALL SIGNALS", all items are monitored. In "MAIN SIGNALS", predetermined items are monitored.
4. Touch "START".
5. Touch "RECORD" while monitoring to record the status of the item being monitored. To stop recording, touch "STOP".

All Signals, Main Signals, Selection From Menu

Item name	CONSULT-II screen display	Display or unit	Monitor item selection			Description
			ALL SIGNALS	MAIN SIGNALS	SELECTION FROM MENU	
Position lights request	TAIL&CLR REQ	ON/OFF	×	×	×	Signal status input from BCM
Headlamp low beam request	HL LO REQ	ON/OFF	×	×	×	Signal status input from BCM
Headlamp high beam request	HL HI REQ	ON/OFF	×	×	×	Signal status input from BCM
Front fog lights request	FR FOG REQ	ON/OFF	×	×	×	Signal status input from BCM

NOTE:

Perform monitoring of IPDM E/R data with ignition switch ON. When ignition switch is at ACC, display may not be correct.

ACTIVE TEST

Operation Procedure

1. Touch "ACTIVE TEST" on "SELECT DIAG MODE" screen.
2. Touch item to be tested, and check operation.
3. Touch "START".
4. Touch "STOP" while testing to stop the operation.

Test item	CONSULT-II screen display	Description
Headlamp relay (HI, LO) output	LAMPS	Allows headlamp relay (HI, LO) to operate by switching operation (OFF, HI ON, LO ON) at your option.
Front fog lamp relay output		Allows front fog lamp relay to operate by switching operation ON-OFF at your option.
Tail lamp relay output	TAIL LAMP	Allows tail lamp relay to operate by switching operation ON-OFF at your option.

AUTO LIGHT SYSTEM

AUTO LIGHT SYSTEM

PPF:28491

Component Parts and Harness Connector Location

NKS000GY

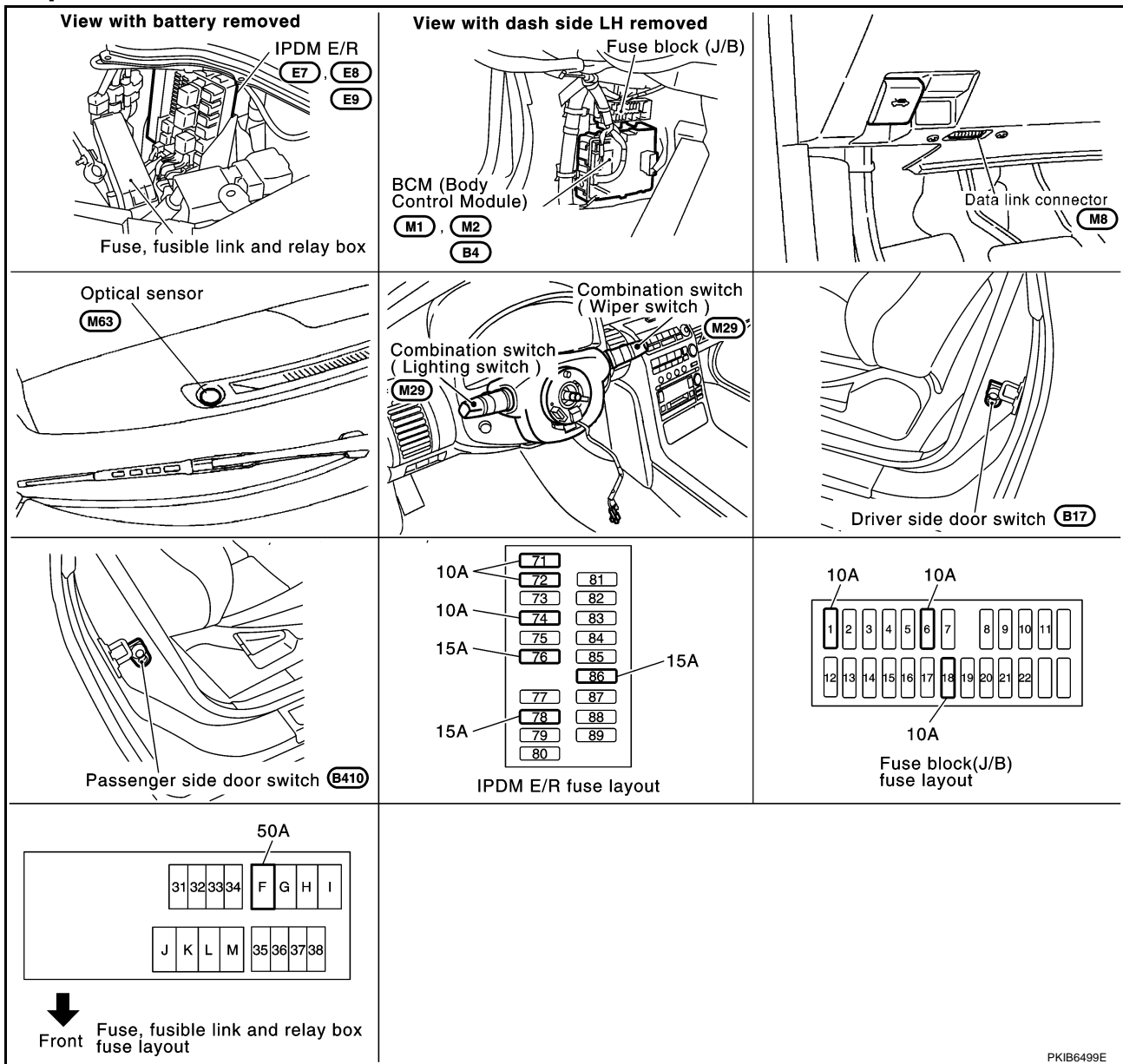

A
B
C
D
E
F
G
H
I
J
LT
L
M

System Description

NKS000GZ

Automatically turns ON/OFF the parking lamps and the headlamps in accordance with ambient light. Timing for when lamps turn ON/OFF can be selected using four modes.

OUTLINE

The auto light control system has an optical sensor inside it that detects outside brightness. When the lighting switch is in AUTO position, it automatically turns ON/OFF the parking lamps and the headlamps in accordance with ambient light. Sensitivity can be adjusted in four steps. For the details of the setting, Refer to [LT-59, "SETTING CHANGE FUNCTIONS"](#).

Optical sensor, power is supplied

- from BCM (body control module) terminal 17
- to optical sensor terminal 1.

Optical sensor, ground is supplied

- to optical sensor terminal 3
- through BCM terminal 18.

When ignition switch is turn to ON position, and

TURN SIGNAL AND HAZARD WARNING LAMPS

LT-TURN-03

— : DATA LINE

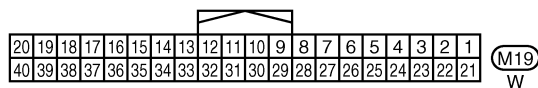
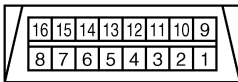
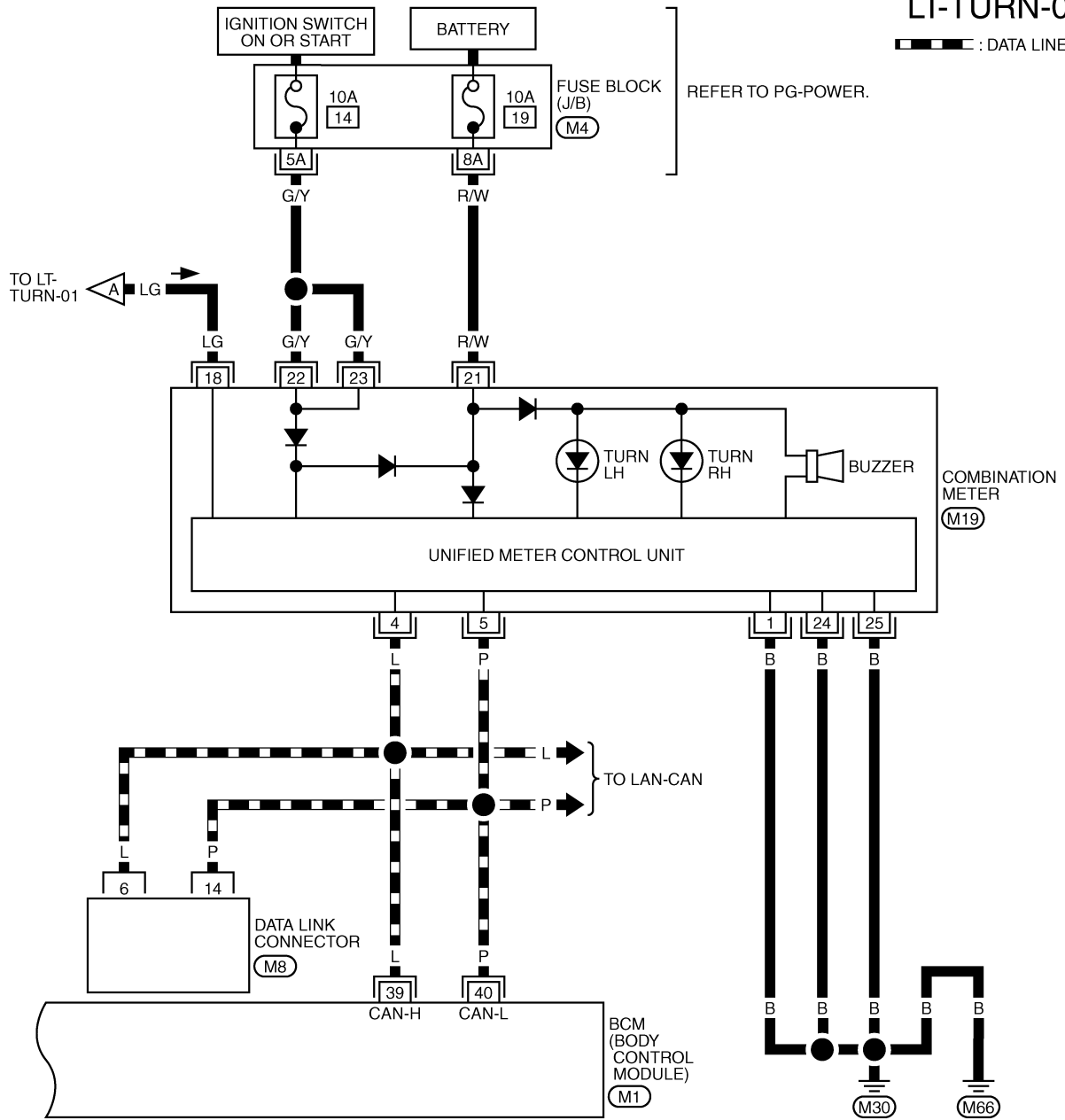

REFER TO THE FOLLOWING.

(M4) - FUSE BLOCK-JUNCTION BOX (J/B)

(M1) - ELECTRICAL UNITS

TKWM2205E

PARKING, LICENSE PLATE AND TAIL LAMPS

LT-TAIL/L-04

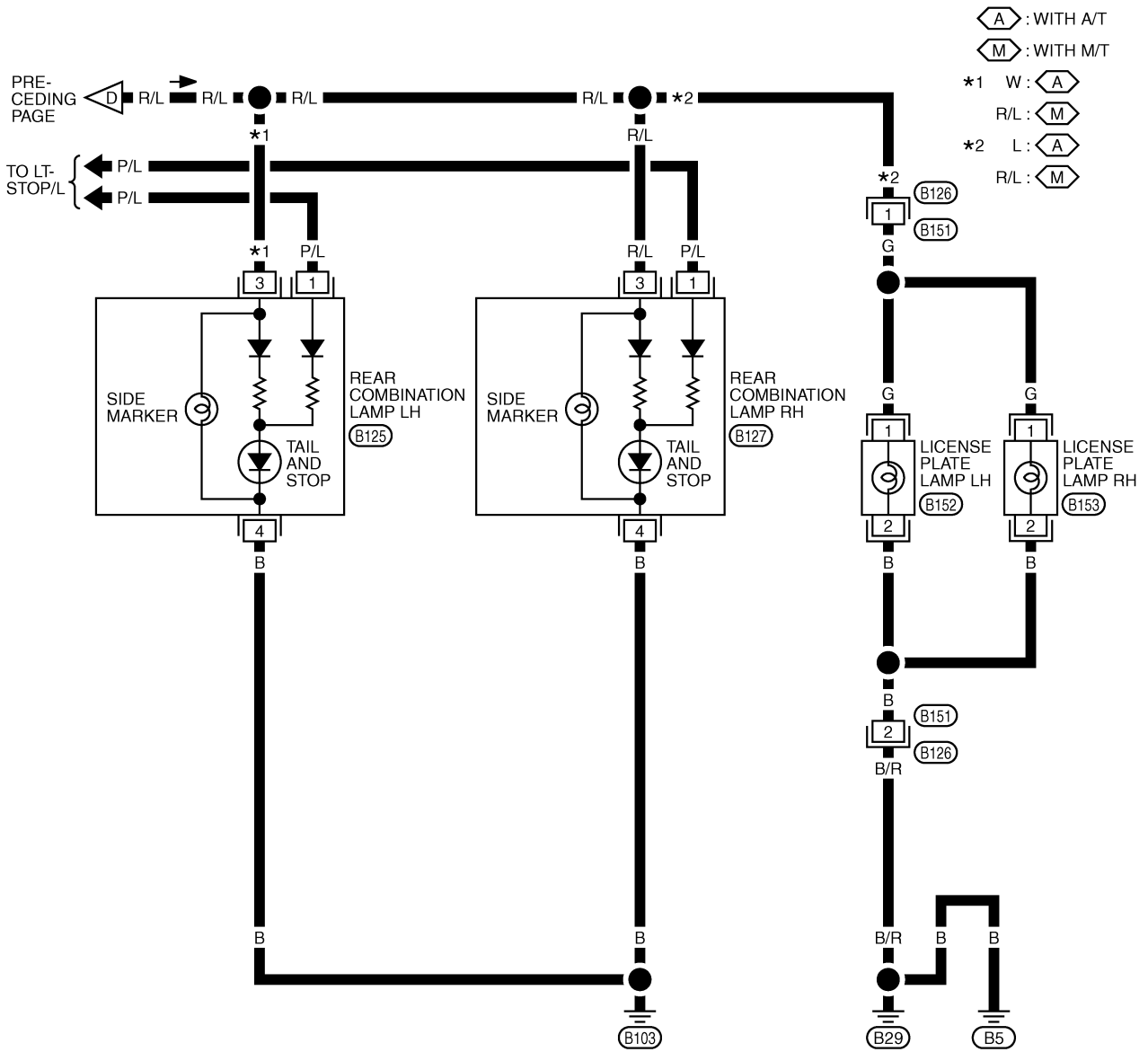

A
B
C
D
E
F
G
H
I
J
LT
L
M

INTERIOR ROOM LAMP

2. ACTIVE TEST

1. Select "BCM" on CONSULT-II. Select "INT LAMP".
2. Select "IGN ILLUM" active test to make sure lamp operates.

Ignition key hole illumination should operate.

OK or NG

- OK >> Replace BCM. Refer to [BCS-16, "Removal and Installation of BCM"](#).
- NG >> GO TO 3.

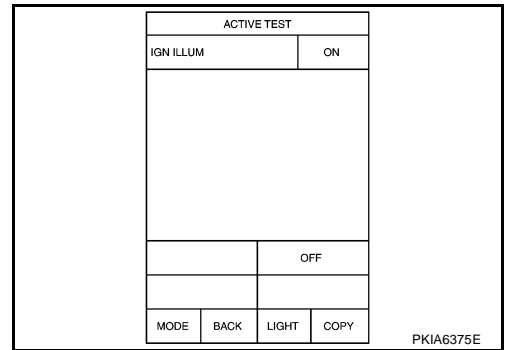

3. CHECK IGNITION KEY HOLE ILLUMINATION INPUT

1. Turn ignition switch OFF.
2. Open the driver side door.
3. Check voltage between ignition key hole illumination harness connector M309 terminal 1 and ground.

1 – Ground : Battery voltage

OK or NG

- OK >> GO TO 4.
- NG >> GO TO 6.

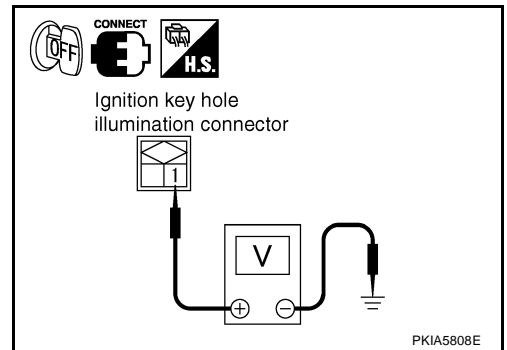

4. CHECK IGNITION KEY HOLE ILLUMINATION BULB

1. Disconnect ignition key hole illumination connector.
2. Check continuity between ignition key hole illumination terminals 1 and 2.

1 – 2 : Continuity should exist.

OK or NG

- OK >> GO TO 5.
- NG >> Replace ignition key hole illumination. Refer to [LT-150, "IGNITION KEY HOLE ILLUMINATION"](#).

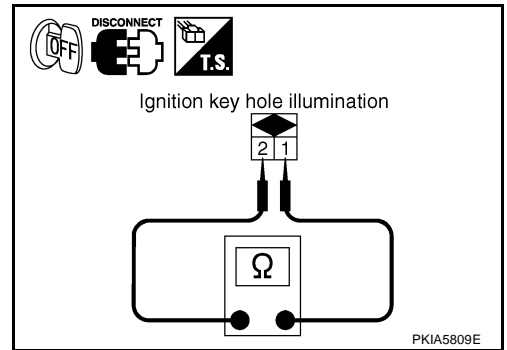

5. CHECK IGNITION KEY HOLE ILLUMINATION CIRCUIT

1. Disconnect BCM connector and key hole illumination connector.
2. Check continuity between BCM harness connector M1 terminal 1 and key hole illumination harness connector M309 terminal 2.

1 – 2 : Continuity should exist.

OK or NG

- OK >> Replace BCM if ignition key hole illumination does not work after setting the connector again. Refer to [BCS-16, "Removal and Installation of BCM"](#).
- NG >> Repair harness or connector.

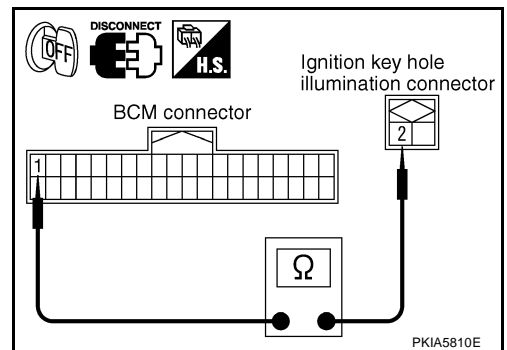

OIL PUMP

PFP:15010

OIL PUMP

Components

NBS002VI

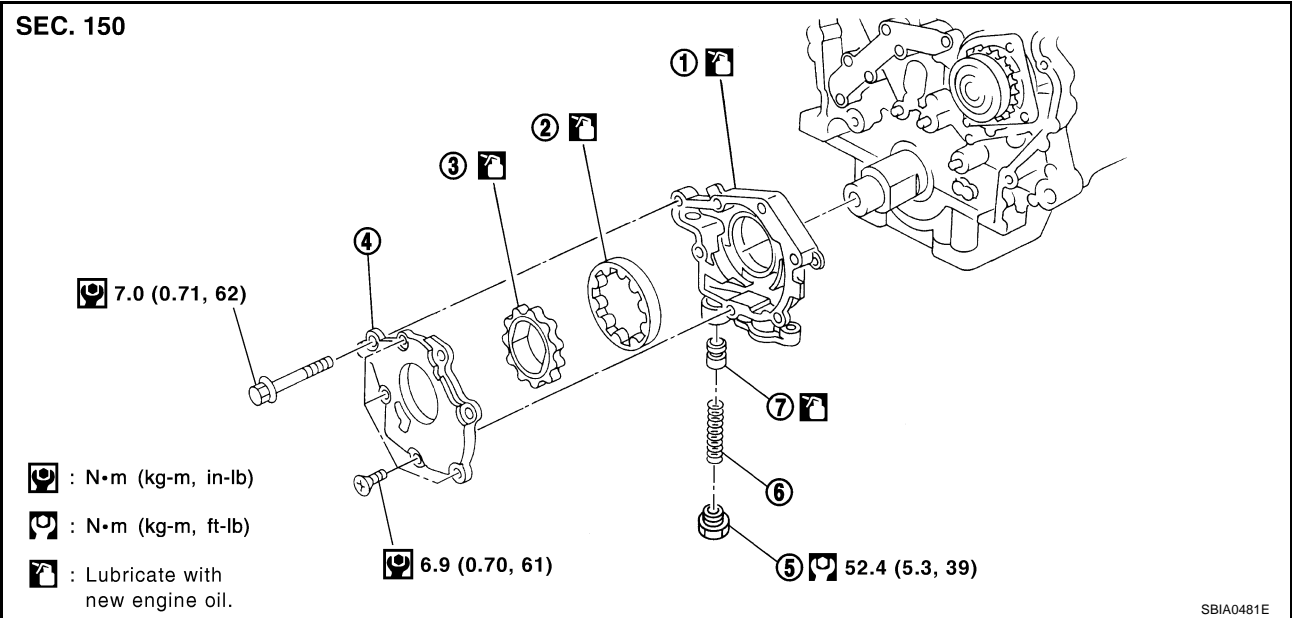

1. Oil pump body
2. Oil pump outer rotor
3. Oil pump inner rotor
4. Oil pump cover
5. Regulator valve plug
6. Regulator valve spring
7. Regulator valve

Removal and Installation

REMOVAL

NBS002VJ

1. Remove oil pans (lower and upper) and oil strainer. Refer to [EM-29, "OIL PAN AND OIL STRAINER"](#).
2. Remove front timing chain case and timing chain (primary). Refer to [EM-59, "TIMING CHAIN"](#).
3. Remove oil pump assembly.

INSTALLATION

CAUTION:

Before installation, apply new engine oil to the parts as instructed in the figure.

Note the following, and install in the reverse order of removal.

- When installing, align crankshaft flat faces with inner rotor flat faces.

INSPECTION AFTER INSTALLATION

1. After warming up engine, check for engine oil leakage.
2. Check the engine oil level and adjust engine oil. Refer to [LU-7, "ENGINE OIL"](#).

Disassembly and Assembly

NBS002VK

DISASSEMBLY

1. Remove oil pump cover.
2. Remove inner rotor and outer rotor from oil pump body.
3. After removing regulator plug, remove regulator spring and regulator valve.

SERVICE DATA AND SPECIFICATIONS (SDS)

SERVICE DATA AND SPECIFICATIONS (SDS)

PFP:00030

Standard and Limit BELT DEFLECTION AND TENSION

NLS00027

	Deflection adjustment		Unit: mm (in)	Tension adjustment*		Unit: N (kg, lb)
	Used belt		New belt	Used belt		New belt
	Limit	After adjustment		Limit	After adjustment	
Alternator and power steering oil pump belt	7 (0.28)	4 - 5 (0.16 - 0.20)	3.5 - 4.5 (0.138 - 0.177)	294 (30, 66)	730 - 818 (74.5 - 83.5, 164 - 184)	838 - 926 (85.5 - 94.5, 188 - 208)
A/C compressor belt	12 (0.47)	9 - 10 (0.35 - 0.39)	8 - 9 (0.31 - 0.35)	196 (20, 44)	348 - 436 (35.5 - 44.5, 78 - 98)	470 - 559 (48 - 57, 106 - 126)
Applied pushing force	98 (10, 22)			—		

SEC.117

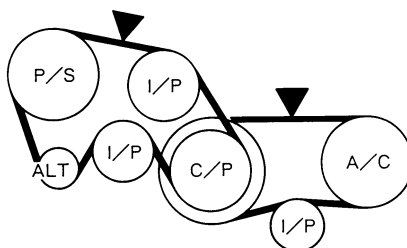

KBIA1731J

*: If belt tension gauge cannot be installed at check points shown, check drive belt tension at different location on the belt.

ENGINE COOLANT CAPACITY

Unit: ℓ (US qt, Imp qt)

Engine coolant capacity (With reservoir tank at MAX level)	8.7 (9-1/4, 7-5/8)
Reservoir tank engine coolant capacity (At MAX level)	0.8 (7/8, 3/4)

ENGINE OIL CAPACITY (APPROXIMATE)

Unit: ℓ (US qt, Imp qt)

Drain and refill	With oil filter change	4.7 (5, 4-1/8)
	Without oil filter change	4.4 (4-5/8, 3-7/8)
Dry engine (Overhaul)		5.4 (5-3/4, 4-3/4)

SPARK PLUG (PLATINUM-TIPPED TYPE)

Type	Standard	PLFR5A-11
	Hot	PLFR4A-11
	Cold	PLFR6A-11
Spark plug gap (Nominal)		1.1 mm (0.043 in)

WHEEL BALANCE

Maximum allowable unbalance	Dynamic (At rim flange)	Less than 5 g (0.17 oz) (one side)
	Static (At rim flange)	Less than 10 g (0.35 oz)

TRANSMISSION ASSEMBLY

10. Drive out retaining pin using a pin punch [6 mm (0.24 in) dia.], and remove 3rd-4th fork rod (reversal side) and 3rd-4th shift fork.

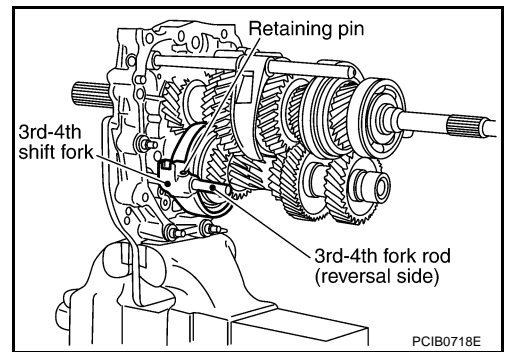

11. Remove check balls and interlock pin from adapter plate.

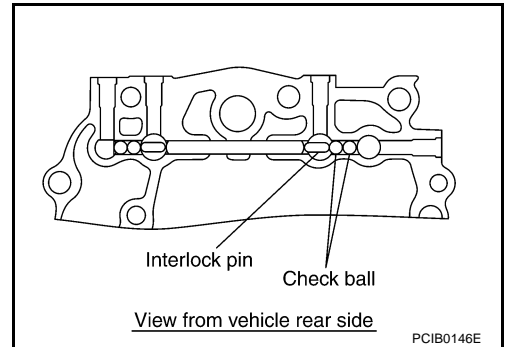

12. Drive out retaining pin using a pin punch [6 mm (0.24 in) dia.], and remove 1st-2nd fork rod and 1st-2nd shift fork.

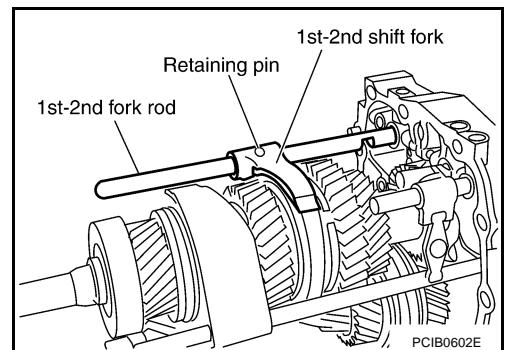

13. Remove interlock plunger and interlock pin from adapter plate.

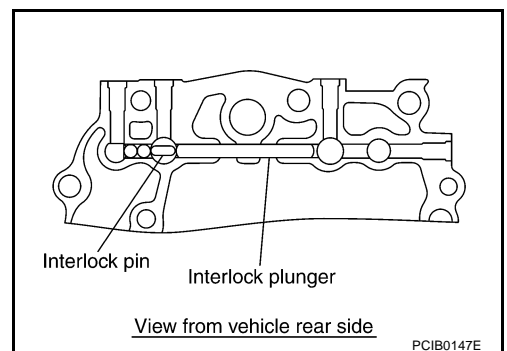

14. Drive out retaining pin using a pin punch [6 mm (0.24 in) dia.], and remove reverse fork rod and reverse shift fork.

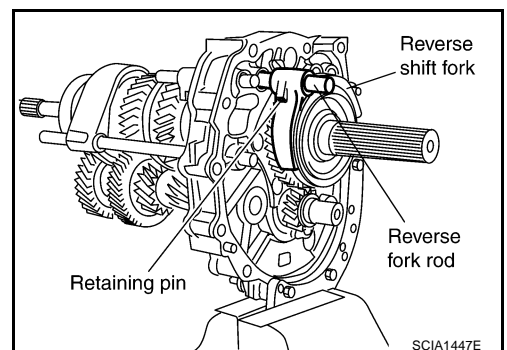

A
B
MT
D
E
F
G
H
I
J
K
L
M

A
B
C
D
E

SECTION **PB**

PARKING BRAKE SYSTEM

CONTENTS

<p>PRECAUTIONS 2</p> <p style="padding-left: 20px;">Precautions for Supplemental Restraint System (SRS) "AIR BAG" and "SEAT BELT PRE-TENSIONER" 2</p> <p>PREPARATION 3</p> <p style="padding-left: 20px;">Commercial Service Tools 3</p> <p>PARKING BRAKE SYSTEM 4</p> <p style="padding-left: 20px;">Inspection and Adjustment (Pedal Type) 4</p> <p style="padding-left: 40px;">INSPECTION 4</p> <p style="padding-left: 40px;">ADJUSTMENT 4</p> <p style="padding-left: 20px;">Inspection and Adjustment (Lever Type) 4</p> <p style="padding-left: 40px;">INSPECTION 4</p> <p style="padding-left: 40px;">ADJUSTMENT 5</p> <p>PARKING BRAKE CONTROL 6</p> <p style="padding-left: 20px;">Components 6</p>	<p style="padding-left: 20px;">Removal and Installation 7</p> <p style="padding-left: 40px;">REMOVAL 7</p> <p style="padding-left: 40px;">INSTALLATION 7</p> <p style="padding-left: 20px;">Inspection 7</p> <p>PARKING BRAKE SHOE 8</p> <p style="padding-left: 20px;">Components 8</p> <p style="padding-left: 20px;">Removal and Installation 8</p> <p style="padding-left: 40px;">REMOVAL 8</p> <p style="padding-left: 40px;">INSPECTION AFTER REMOVAL 9</p> <p style="padding-left: 40px;">INSTALLATION 10</p> <p style="padding-left: 40px;">BREAKING IN DRUM AND LINING 10</p> <p>SERVICE DATA AND SPECIFICATIONS (SDS) 11</p> <p style="padding-left: 20px;">Parking Drum Brake 11</p> <p style="padding-left: 20px;">Parking Brake Control 11</p>	<p>PB</p> <p>G</p> <p>H</p> <p>I</p> <p>J</p> <p>K</p> <p>L</p> <p>M</p>
---	---	--

Auto Active Test DESCRIPTION

- In auto active test mode, operation inspection can be performed when IPDM E/R sends a drive signal to the following systems:
 - Rear window defogger
 - Front wiper
 - Parking, license plate, side marker and tail lamps
 - Front fog lamps
 - Headlamps (HI, LO)
 - A/C compressor (magnetic clutch)
 - Cooling fan

OPERATION PROCEDURE

1. Close hood and front door (passenger side) and then lift wiper arms away from windshield (to prevent glass damage by wiper operation).

NOTE:

When auto active test is performed with hood opened, sprinkle water on windshield beforehand.

2. Turn ignition switch OFF.
3. Turn ignition switch ON, and within 20 seconds, press drivers door switch 10 times (close other door). Then turn ignition switch OFF.
4. Turn ignition switch ON within 10 seconds after ignition switch OFF.
5. When auto active test mode is actuated, horn chirps once. Oil pressure warning lamp starts blinking.
6. After a series of operations is repeated three times, auto active test is completed.

NOTE:

When auto active test mode has to be cancelled halfway, turn ignition switch OFF.

CAUTION:

Be sure to inspect [BL-39. "Check Door Switch"](#) when the auto active test cannot be performed.

INSPECTION IN AUTO ACTIVE TEST MODE

When auto active test mode is actuated, the following eight steps are repeated three times.

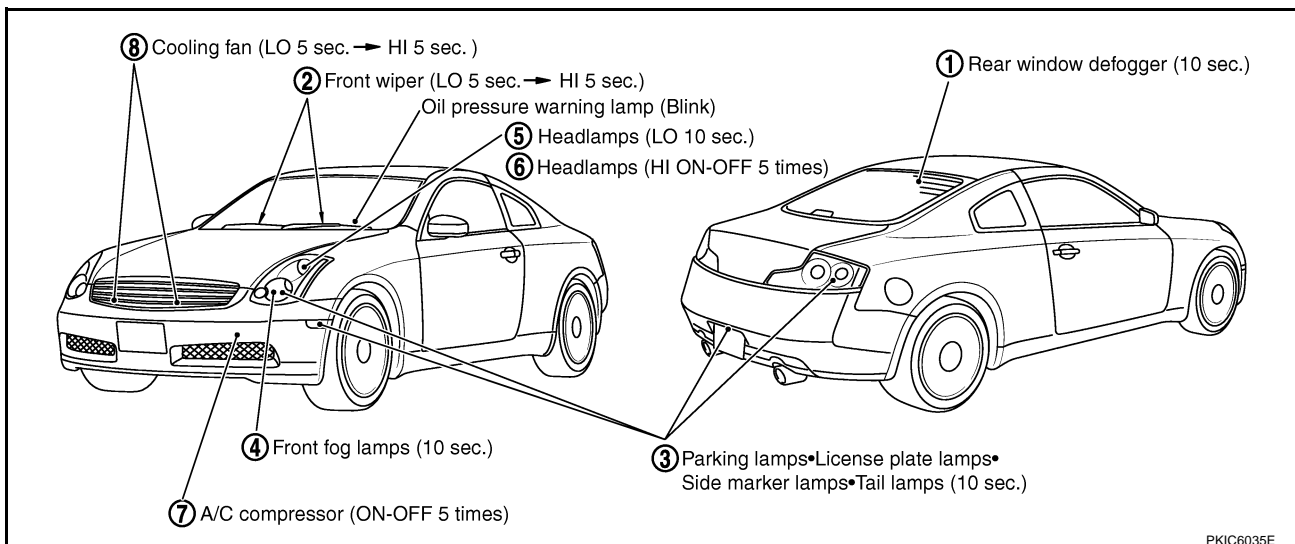

HARNESS

Trunk Room

- (B103) — : Body ground
- (B113) SB/4 : Rear wheel sensor
- (B116) BR/2 : High-mounted stop lamp (On the rear parcel shelf)
- (B117) W/2 : Trunk room lamp
- (B120) W/2 : Woofer LH (With BOSE system)
- (B121) W/2 : Woofer RH (With BOSE system)
- (B122) B/24 : BOSE speaker amp. (With BOSE system)
- (B123) GY/8 : BOSE speaker amp. (With BOSE system)
- (B124) W/16 : Option connector for satellite radio tuner
- (B125) W/6 : Rear combination lamp LH
- (B126) GY/2 : To (B151)
- (B127) W/6 : Rear combination lamp RH
- (B128) GY/3 : EVAP control system pressure sensor
- (B129) B/2 : EVAP canister vent control valve
- (B131) GY/2 : Outside key antenna
- (B133) (Rear bumper) (With Intelligent Key)
- (B134) SB/6 : Rear wheel steering angle sensor (With RAS)
- (B135) B/2 : RAS motor (With RAS)
- (B136) B/1 : RAS motor (With RAS)
- (B136) W/40 : RAS control unit (With RAS)

- (B137) W/2 : Noise suppressor (With RAS)
- (B138) W/3 : Noise suppressor (With RAS)
- (B139) L/4 : RAS motor relay (With RAS)
- (B140) W/32 : TEL adapter unit (With telephone system)

License plate sub-harness

- (B151) GY/2 : To (B126)
- (B152) BR/2 : License plate lamp LH
- (B153) BR/2 : License plate lamp RH

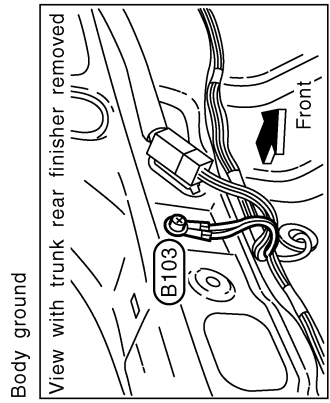
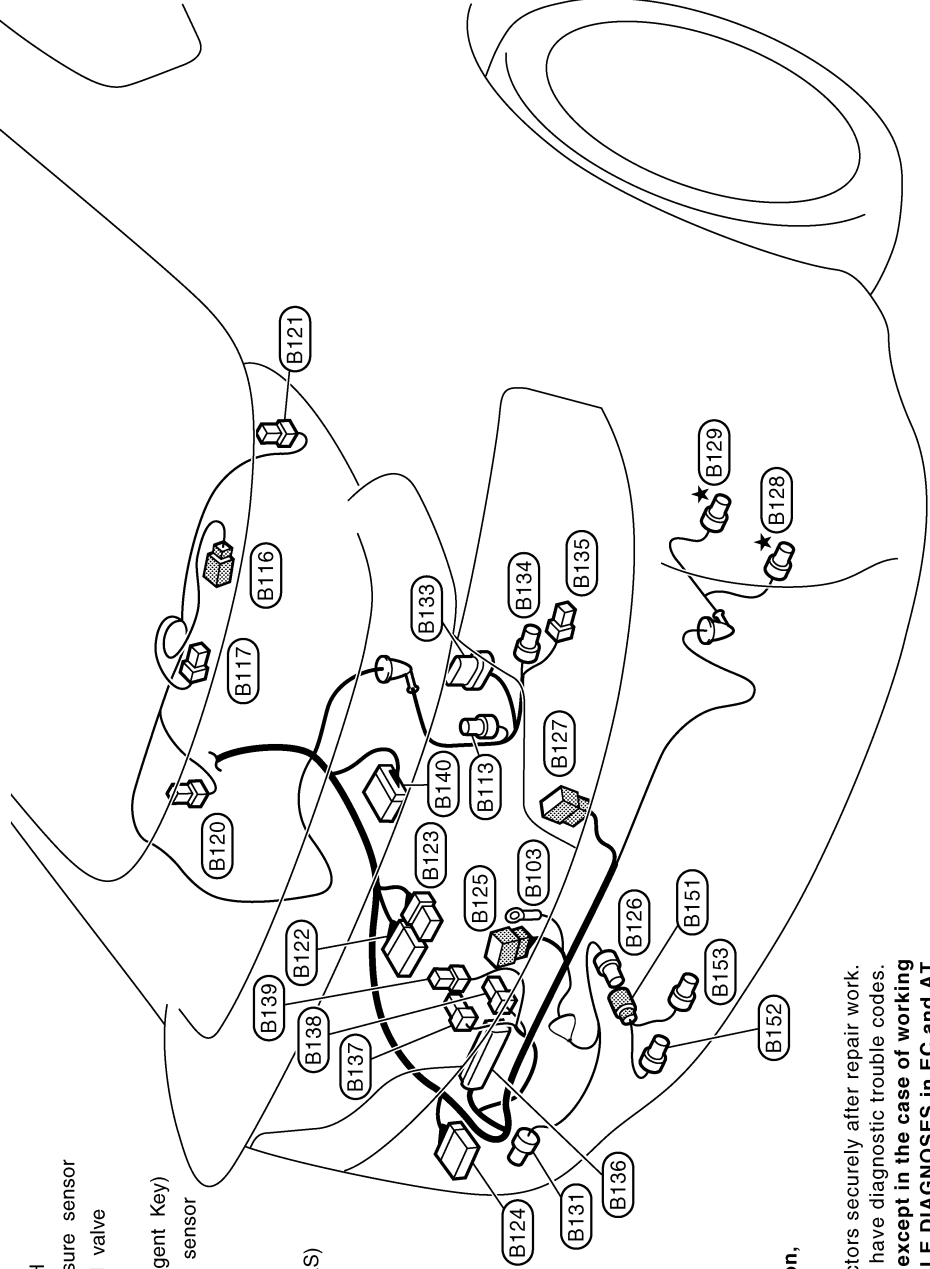

For detail ground distribution information, refer to "GROUND DISTRIBUTION".

★ : Be sure to connect and lock the connectors securely after repair work. Failure to do so may cause the ECM to have diagnostic trouble codes. Do not disconnect these connectors except in the case of working according to WORK FLOW of TROUBLE DIAGNOSES in EC and AT sections.

A
B
C
D
E
F
G
H
I
J
L
M
PG

A
B
C
D
E
F
PS
H
I
J
K
L
M

SECTION PS

POWER STEERING SYSTEM

CONTENTS

PRECAUTIONS	3	SHAFT, HOLE COVER, CLAMP, HOLE COVER SEAL, COLLAR AND UPPER JOINT	14
Precautions for Supplemental Restraint System (SRS) "AIR BAG" and "SEAT BELT PRE-TENSIONER"	3	REMOVAL OF STEERING COLUMN ASSEMBLY	14
Precautions for Battery Service	3	INSPECTION AFTER REMOVAL OF STEERING COLUMN ASSEMBLY	15
Service Notice or Precautions for Steering System....	3	INSTALLATION OF STEERING COLUMN ASSEMBLY	15
PREPARATION	4	INSPECTION AFTER INSTALLATION OF STEERING COLUMN ASSEMBLY	15
Special Service Tools	4	Disassembly and Assembly	15
Commercial Service Tools	5	COMPONENTS	15
NOISE, VIBRATION AND HARSHNESS (NVH)		DISASSEMBLY	16
TROUBLESHOOTING	6	INSPECTION AFTER DISASSEMBLY	16
NVH Troubleshooting Chart	6	ASSEMBLY	16
POWER STEERING FLUID	7	INSPECTION AFTER ASSEMBLY	16
Checking Fluid Level	7	COMPONENTS (ELECTRICITY TYPE)	17
Checking Fluid Leakage	7	DISASSEMBLY	18
Air Bleeding Hydraulic System	7	INSPECTION AFTER DISASSEMBLY	18
STEERING WHEEL	9	ASSEMBLY	18
On-Vehicle Inspection and Service	9	INSPECTION AFTER ASSEMBLY	18
CHECKING CONDITION OF INSTALLATION	9	POWER STEERING GEAR AND LINKAGE	19
CHECKING STEERING WHEEL PLAY	9	Removal and Installation	19
CHECKING NEUTRAL POSITION ON STEERING WHEEL	9	COMPONENTS (WITHOUT EPS)	19
CHECKING STEERING WHEEL TURNING FORCE	9	COMPONENTS (WITH EPS)	19
CHECKING FRONT WHEEL TURNING ANGLE..	10	REMOVAL	19
Removal and Installation	11	INSTALLATION	21
REMOVAL	11	POWER STEERING GEAR	22
INSTALLATION	11	Disassembly and Assembly	22
Disassembly and Assembly	11	COMPONENTS	22
COMPONENTS	11	DISASSEMBLY	23
DISASSEMBLY	12	INSPECTION AFTER DISASSEMBLY	24
ASSEMBLY	12	ASSEMBLY	26
STEERING COLUMN	13	POWER STEERING OIL PUMP	31
Removal and Installation	13	On-Vehicle Inspection and Service	31
COMPONENTS	13	CHECKING RELIEF OIL PRESSURE	31
REMOVAL OF LOWER JOINT, LOWER SHAFT, HOLE COVER, CLAMP, HOLE COVER SEAL, COLLAR AND UPPER JOINT	14	Removal and Installation	31
INSTALLATION OF LOWER JOINT, LOWER		REMOVAL	31

POWER STEERING OIL PUMP

INSPECTION BEFORE DISASSEMBLY

Disassemble power steering oil pump only if the following items are found.

- Oil leakage from oil pump
- Deformed or damaged pulley
- Poor performance

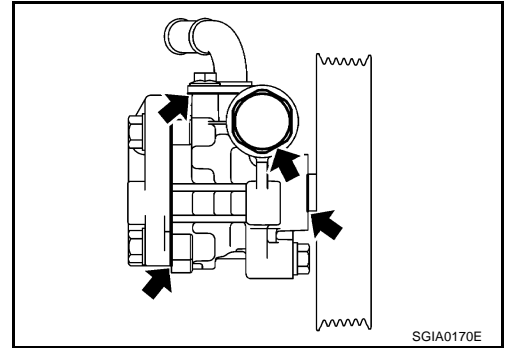

DISASSEMBLY

NOTE:

Fix oil pump in vise as the occasion demands.

CAUTION:

When retaining drive shaft in a vise, always use copper or aluminum plates between vise and shaft.

1. Unscrew two front bracket bolts and remove bracket from body assembly.
2. Unscrew four cover assembly bolts and remove cover assembly from body assembly.
3. Remove O-ring A from body assembly.
4. Remove rotor snap ring with snap ring pliers, and remove shaft kit from body assembly.

CAUTION:

When removing rotor snap ring, be careful not to damage pulley shaft of shaft kit.

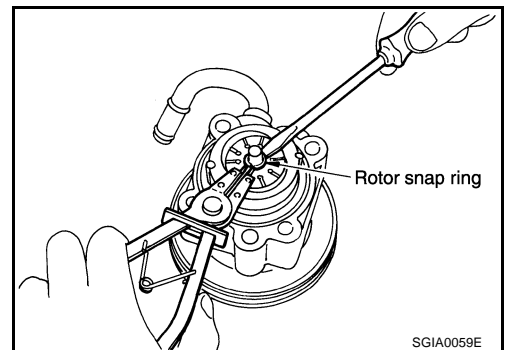

5. Using a screw driver, remove oil seal for body assembly.
6. Remove cam ring, rotor, vane, side plate, O-ring B and O-ring C from body assembly.
7. Remove plug, then remove O-ring D, flow control valve spring, relief valve assembly and flow control valve assembly from body assembly.

CAUTION:

Be careful not to drop and deform relief valve assembly and flow control valve assembly.

8. Remove fixing bolt of suction connector assembly, then remove suction connector assembly and O-ring E from body assembly.

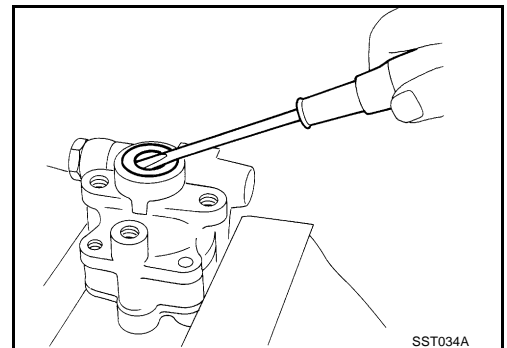

INSPECTION AFTER DISASSEMBLY

Body Assembly and Cover Assembly Inspection

- Check body assembly and cover assembly for damage. If any damage is found, replace with new part for cover assembly, and replace with new power steering pump assembly for body assembly.

Cartridge Assembly Inspection

- Check cam ring, side plate, rotor and vanes for damage. If any damage is found, replace cartridge assembly with new one.

Relief Valve Assembly Inspection

- Check relief valve assembly for damage. If any damage is found, replace it with new one.

SUNROOF

INITIALIZATION PROCEDURE

If the sunroof does not close or open automatically, use the following procedure to return sunroof operation to normal.

1. Close the sunroof if it is not in the closed position. It may be necessary to repeatedly push the switch to close the sunroof.
2. Press and hold the TILT UP switch. Do not release the switch, keep pressure on it. After 10 seconds of depressing, the sunroof will tilt up, then stop. Release the button.
3. Press and hold the TILT UP switch again. Do not release the switch, keep pressure on it. While depressing the switch, the sunroof will "Tilt down" "Slide open" "Slide close". Release the button after the sunroof "Tilt down" and stops.
4. Initializing procedure is complete. Confirm proper operation of the sunroof.

INTERRUPTION DETECTION FUNCTION

The CPU of sunroof motor monitors the sunroof motor operation and the sunroof position (fully-closed or other) by the signals from sunroof motor.

When sunroof motor detects an interruption during the following sliding close operation, sunroof switch controls the motor for open and the sunroof will operate until full open position.

- automatic close operation when ignition switch is in the ON position
- automatic close operation during retained power operation

CAN Communication System Description

NIS000FX

CAN (Controller Area Network) is a serial communication line for real time application. It is an on-vehicle multiplex communication line with high data communication speed and excellent error detection ability. Many electronic control units are equipped onto a vehicle, and each control unit shares information and links with other control units during operation (not independent). In CAN communication, control units are connected with 2 communication lines (CAN H line, CAN L line) allowing a high rate of information transmission with less wiring. Each control unit transmits/receives data but selectively reads required data only.

CAN Communication Unit

NIS000FY

Refer to [LAN-47, "CAN System Specification Chart"](#)

FRONT OIL SEAL

4. Apply anti-corrosion oil to the thread and seat of new drive pinion lock nut, and temporarily tighten drive pinion lock nut to drive pinion.

CAUTION:

Do not reuse drive pinion lock nut.

5. Tighten to drive pinion lock nut, while adjust total preload torque.

Tool number A: ST3127S000 (J-25765-A)

Drive pinion lock nut tightening torque:

147 – 323 N-m (15 – 32 kg-m, 109 – 238 ft-lb)

Total preload torque:

Total preload torque should equal the measurement taken during removal plus an additional 0.1 – 0.4 N-m (0.01 – 0.04 kg-m, 1 – 3 in-lb).

CAUTION:

- Adjust to the lower limit of the drive pinion lock nut tightening torque first.
- If the preload torque exceeds the specified value, replace collapsible spacer and tighten it again to adjust. Do not loosen drive pinion lock nut to adjust the preload torque.

6. Make a stamping for identification of front oil seal replacement frequency. Refer to [RFD-10, "IDENTIFICATION STAMP OF REPLACEMENT FREQUENCY OF FRONT OIL SEAL"](#).

CAUTION:

Be sure to make a stamping after replacing front oil seal.

7. Install propeller shaft. Refer to [PR-4, "Removal and Installation"](#).
8. Install side flange with the following procedure.

NOTE:

Install the RH side flange, then install the LH side flange. If LH side flange is installed first, the RH side flange comes out sometimes from the shock of installing the RH side flange. [For R200V (with LSD)]

- a. Attach the protector to side oil seal.

Tool number : KV38107900 (J-39352)

- b. After the side flange is inserted and the serrated part of side gear has engaged the serrated part of flange, remove the protector.

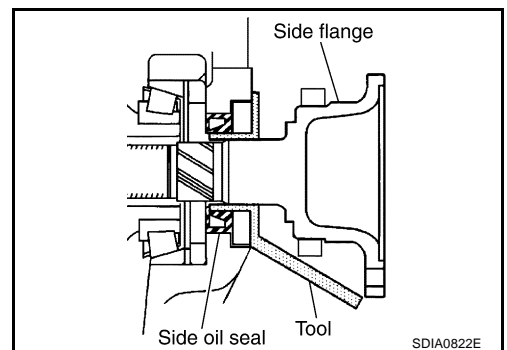
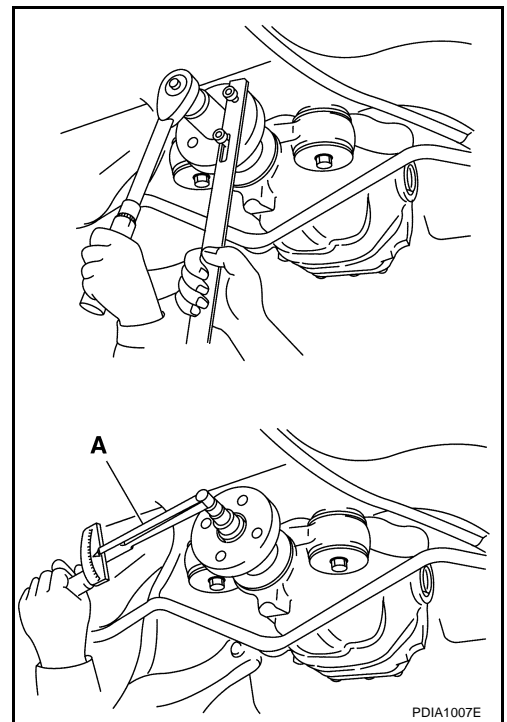

A

B

C

RFD

E

F

G

H

I

J

K

L

M

REAR FINAL DRIVE ASSEMBLY

8. Lift differential case assembly out with a suitable tool.

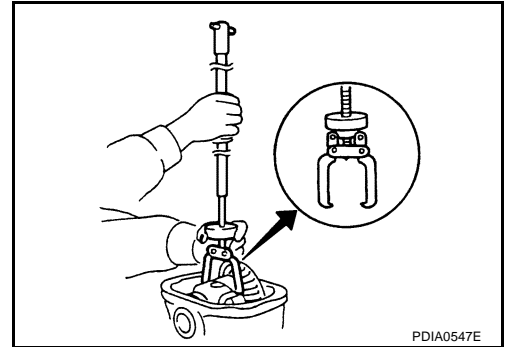

- Keep side bearing outer races together with inner race. Do not mix them up. Also, keep side bearing adjusting washers together with bearings.

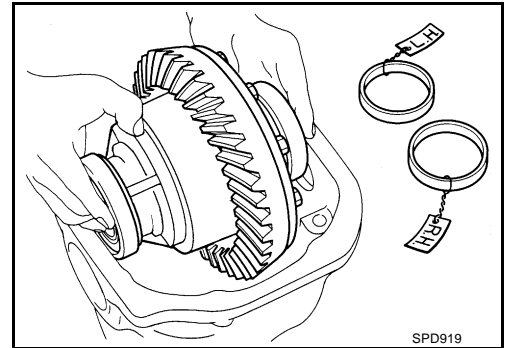

9. Remove side bearing inner race.
To prevent damage to bearing, engage puller jaws in groove.

Tool number **A: ST33051001 (J-22888-20)**
 B: ST33061000 (J-8107-2)

CAUTION:

- To prevent damage to the side bearing and drive gear, place copper plates between these parts and vise.
- It is not necessary to remove side bearing inner race except it is replaced.

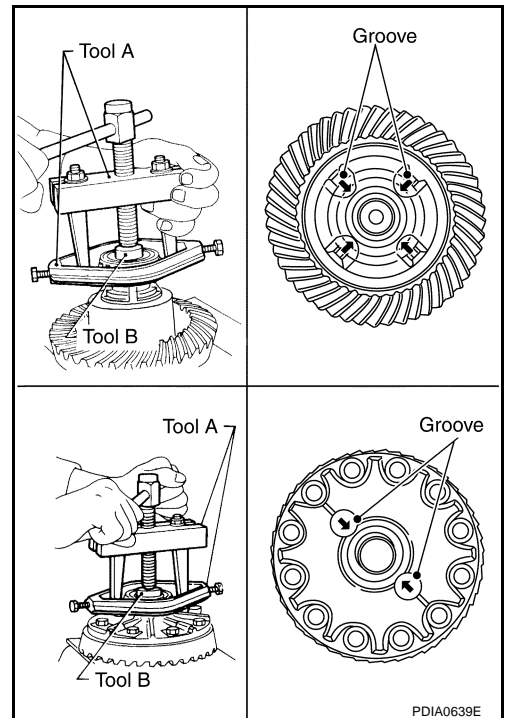

10. For proper reinstallation, paint matching mark on one differential case assembly.

- CAUTION:**
For matching mark, use paint. Do not damage differential case and drive gear.

11. Remove drive gear mounting bolts.
12. Tap drive gear off differential case assembly with a soft hammer.

- CAUTION:**
Tap evenly all around to keep drive gear from bending.

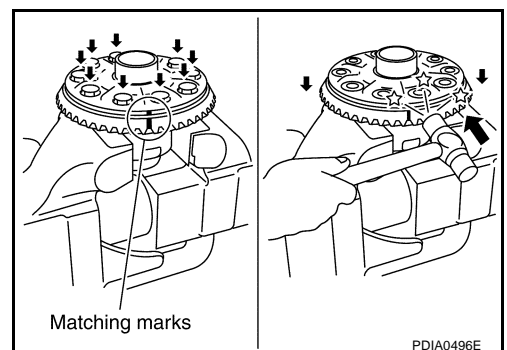

A
B
C
RFD
E
F
G
H
I
J
K
L
M

REAR SUSPENSION MEMBER

REAR SUSPENSION MEMBER

PFP:55501

Removal and Installation

NES0002W

REMOVAL

1. Remove tires from vehicle with power tool.
2. Remove brake caliper with power tool. Hang it in a place where it will not interfere with work. Refer to [BR-27, "REAR DISC BRAKE"](#).

NOTE:

Avoid depressing brake pedal while brake caliper is removed.

3. Remove exhaust front tube. Refer to [EX-3, "EXHAUST SYSTEM"](#).
4. Remove stabilizer bar. Refer to [RSU-16, "STABILIZER BAR"](#).
5. Remove drive shaft. Refer to [RAX-10, "REAR DRIVE SHAFT"](#).
6. Remove final drive. Refer to [RFD-17, "REAR FINAL DRIVE ASSEMBLY"](#).
7. Separate the attachment between parking brake cable and vehicle and rear suspension member. Refer to [PB-6, "PARKING BRAKE CONTROL"](#).
8. Remove rear lower link and coil spring. Refer to [RSU-15, "REAR LOWER LINK & COIL SPRING"](#).
9. Remove mounting bolt in lower side of shock absorber. Refer to [RSU-9, "SHOCK ABSORBER"](#).
10. Set jack under rear suspension member.
11. Remove mounting bolts and nuts tunnel stay and member stay from vehicle.
12. Remove mounting bolts and nuts of rear pin stay and then remove rear pin stay from vehicle.
13. Slowly lowering jack, then remove rear suspension member, suspension arm, radius rod, front lower link and axle from vehicle as a unit.
14. Remove mounting bolts and nuts, then remove suspension arm, front lower link, radius rod from rear suspension member.

INSPECTION AFTER REMOVAL

Check rear suspension member for deformation, cracks, and other damage and replace if necessary.

INSTALLATION

- Refer to [RSU-7, "Components"](#), for tightening torque. Install in the reverse order of removal.

NOTE:

Refer to component parts location and do not reuse non-reusable parts.

- Perform final tightening of installation position of links (rubber bushing) under unladen condition with tires on level ground. Check wheel alignment. Refer to [RSU-18, "SERVICE DATA AND SPECIFICATIONS \(SDS\)"](#).

STARTING SYSTEM

Removal and Installation

NKS000F0

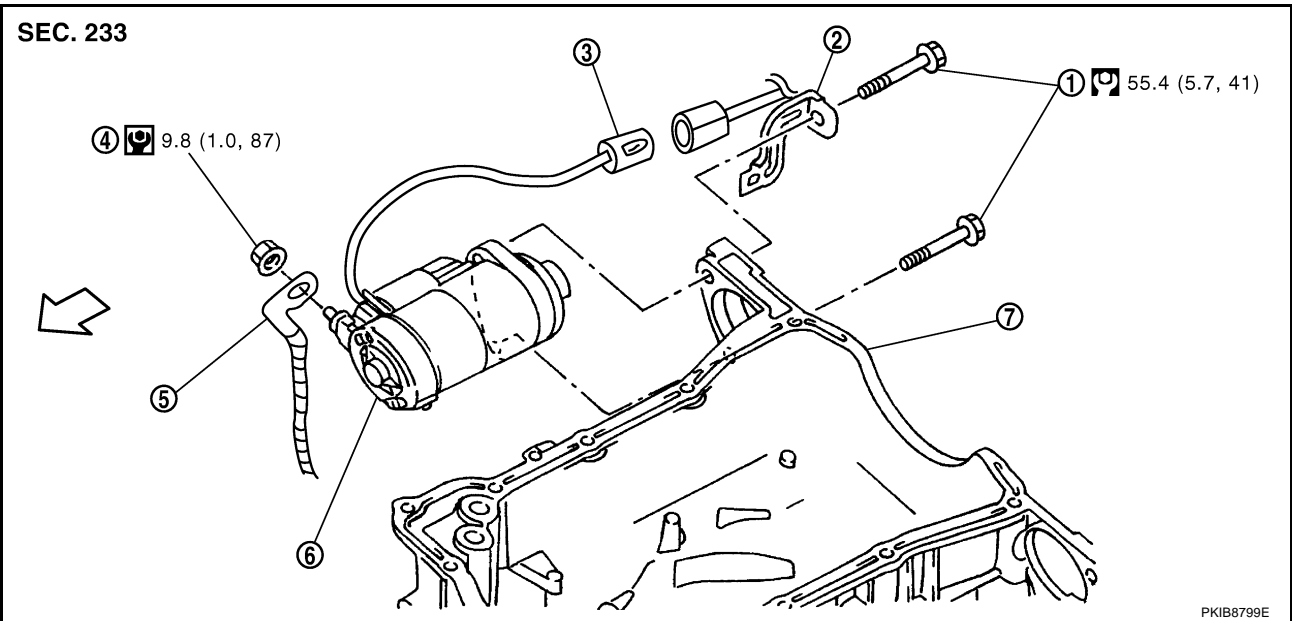

1. Starter motor mounting bolt
2. Harness clip bracket
3. S connector
4. B terminal nut
5. B terminal harness
6. Starter motor
7. Oil pan

: N·m (kg-m, ft-lb)

: N·m (kg-m, in-lb)

: Engine front

REMOVAL

1. Open the driver and front passenger window, and then disconnect the battery cable from the negative terminal.

CAUTION:

Before disconnecting the battery, lower both the driver and passenger windows. This will prevent any interference between the window edge and the vehicle when the door is opened/closed. During normal operation, the window slightly raises and lowers automatically to prevent any window to vehicle interference. The automatic window function will not work with the battery disconnected.

2. Remove engine rear undercover, using power tools.
3. Disconnect "S" connector.
4. Remove "B" terminal nut.
5. Remove starter motor mounting bolts and harness connector clip bracket, using power tools.
6. Remove starter motor downward.

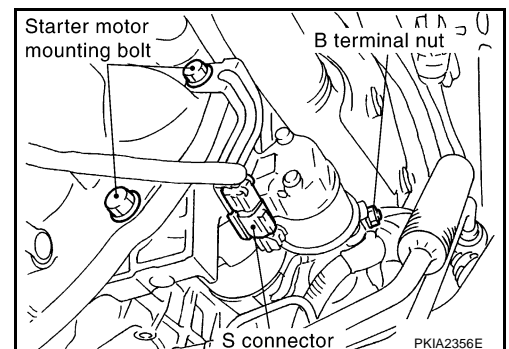

INSTALLATION

Installation is the reverse order of removal.

CAUTION:

Be sure to tighten "B" terminal nut carefully.

AUTOMATIC DRIVE POSITIONER

NIS001HA

Component Parts and Harness Connector Location

A
B
C
D
E
F
G
H
SE
J
K
L
M

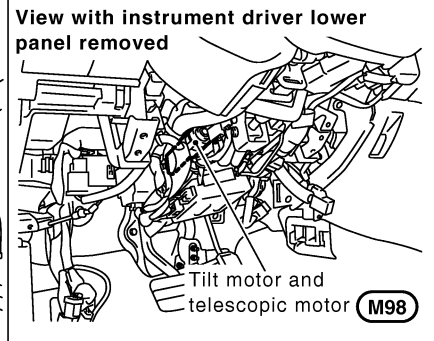
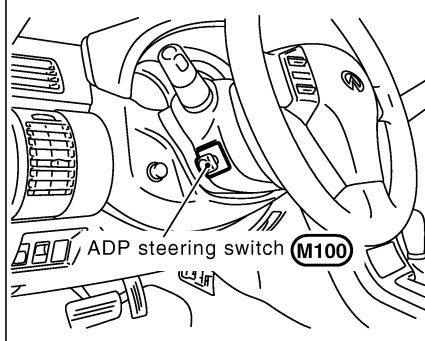
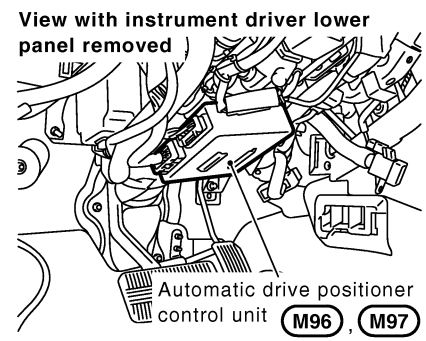
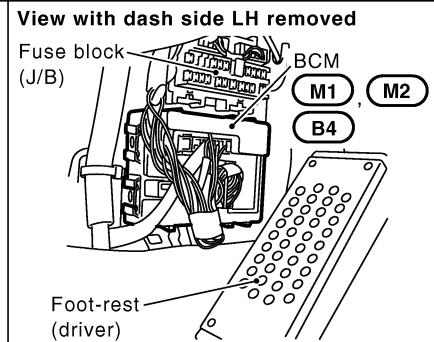
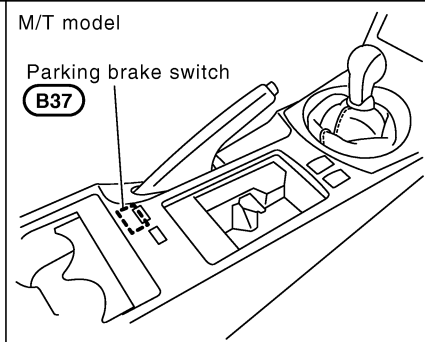
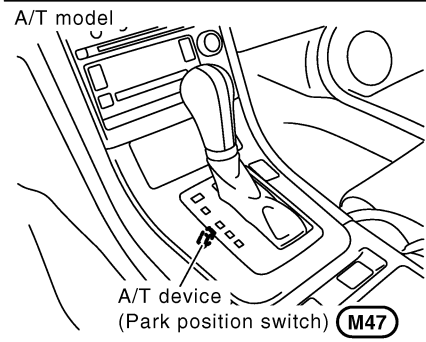
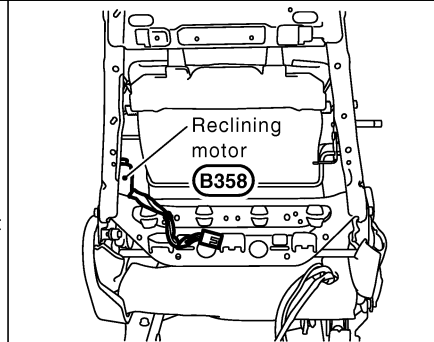
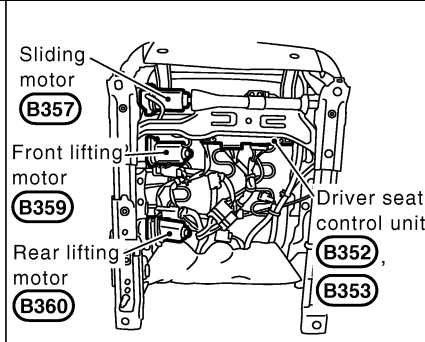
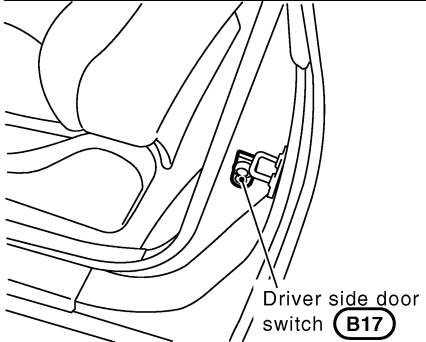
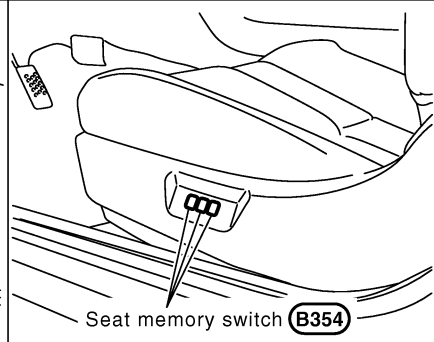
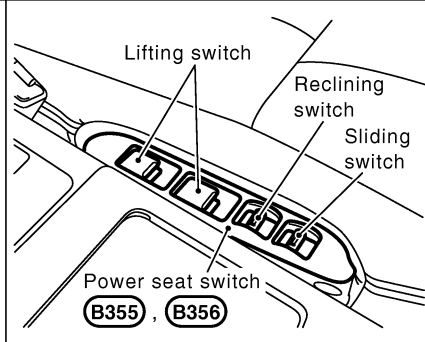
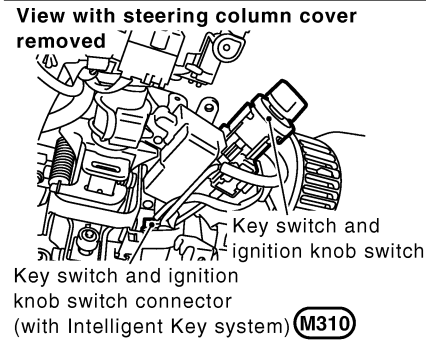
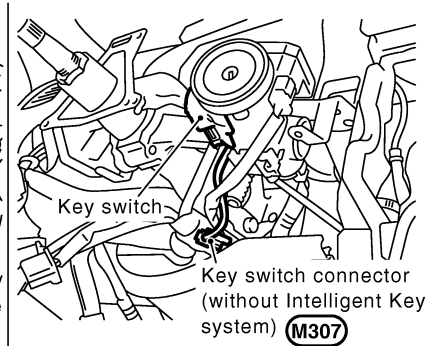
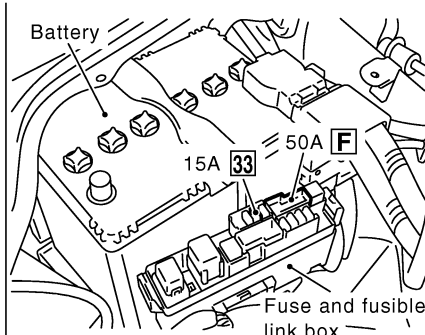
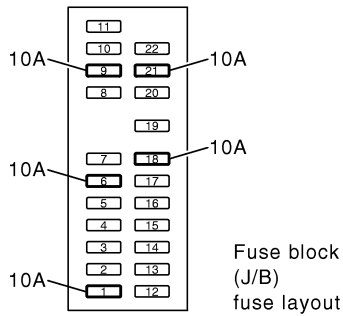

PIIB7391E

AUTOMATIC DRIVE POSITIONER

2. CHECK FUNCTION

With CONSULT-II

Check operation with "TILT MOTOR" in ACTIVE TEST.

Test item	Description
TILT MOTOR	The tilt motor is activated by receiving the drive signal.

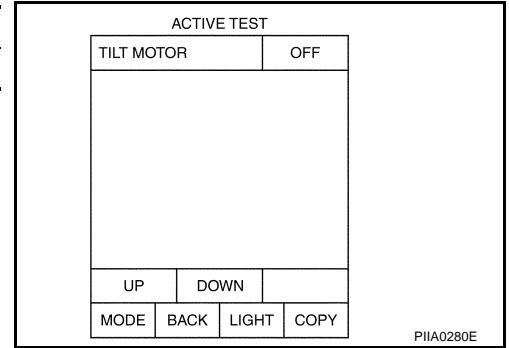

Without CONSULT-II

GO TO 3.

OK or NG

OK >> Steering tilt motor circuit is OK.

NG >> GO TO 3.

3. CHECK TILT MOTOR CIRCUIT HARNESS CONTINUITY

- Turn ignition switch OFF.
- Disconnect automatic drive positioner control unit connector and tilt and telescopic motor connector.
- Check continuity between automatic drive positioner control unit connector M97 terminals 35, 42 and tilt and telescopic motor connector M98 terminals 1, 2.

35 (G/Y) – 1 (G/Y) : Continuity should exist.

42 (G/W) – 2 (G/W) : Continuity should exist.

- Check continuity between automatic drive positioner control unit connector M97 terminals 35, 42 and ground.

35 (G/Y) – Ground : Continuity should not exist.

42 (G/W) – Ground : Continuity should not exist.

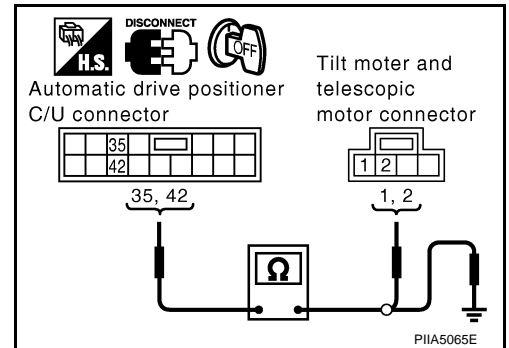

OK or NG

OK >> GO TO 4.

NG >> Repair or replace harness between automatic drive positioner control unit and tilt and telescopic motor.

AUTOMATIC DRIVE POSITIONER

2. CHECK HARNESS CONTINUITY

1. Disconnect driver seat control unit and seatback switch connector.
2. Check continuity between driver seat control unit connector B353 terminal 41 and seatback switch connector B348 terminal 1.

41 (L) - 1 (L) : Continuity should exist.

OK or NG

- OK >> GO TO 3.
 NG >> Repair or replace harness between driver seat control unit and seatback switch.

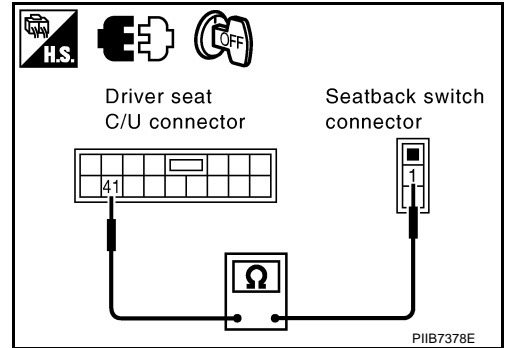

3. CHECK SEATBACK SWITCH CIRCUIT

Check continuity between seatback switch connector B348 terminal 2 and ground.

2 (B) - Ground : Continuity should exist.

OK or NG

- OK >> GO TO 4.
 NG >> Repair or replace harness.

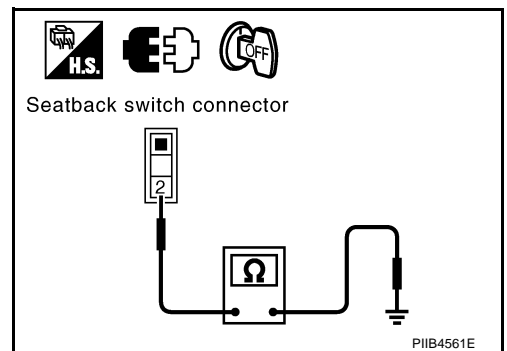

4. CHECK SEATBACK SWITCH

Check continuity between seatback switch connector B348 terminals 1 and 2.

Connector	Terminal		Condition	Continuity
B348	1	2	When seatback switch forward	Yes
			Other than above	No

OK or NG

- OK >> Check the condition of the harness and the connector.
 NG >> Replace seatback switch.

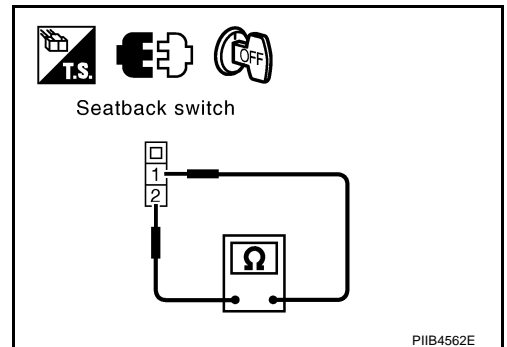

Check Power Walk-in Switch Signal

1. CHECK POWER WALK-IN SWITCH SIGNAL

Check voltage between driver seat control unit connector B353 terminal 34 and ground.

Connector	Terminal		Condition	Voltage (V) (Approx.)
	(+)	(-)		
B353	34 (G)	Ground	When power walk-in switch ON	0
			Other than above	5

OK or NG

- OK >> Power walk-in switch signal is OK.
 NG >> GO TO 2.

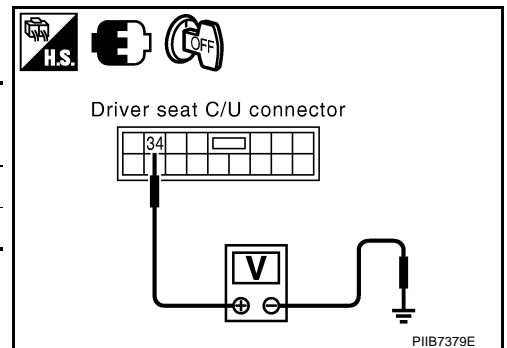

POWER SEAT

3. CHECK LIFTING MOTOR (FRONT) CIRCUIT HARNESS

1. Check continuity between power seat switch connector B326 terminal 9, 10 and lifting motor (front) connector B327 terminal 1, 2.

10 (L/R) - 1 (L/R) : Continuity should exist.
9 (OR) - 2 (OR) : Continuity should exist.

2. Check continuity between power seat switch connector B326 terminal 9, 10 and ground.

10 (L/R) - Ground : Continuity should not exist.
9 (OR) - Ground : Continuity should not exist.

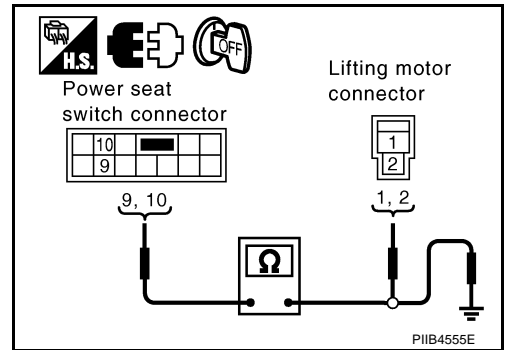

OK or NG

OK >> GO TO 4.

NG >> Repair or replace harness between power seat switch and lifting motor (front).

4. CHECK POWER SEAT SWITCH 2

Check continuity between power seat switch as follows.

Terminal		Condition	Continuity
10	1	UP SW: ON	Yes
		Other than above	No
9	1	DOWN SW: ON	Yes
		Other than above	No

OK or NG

OK >> Check the condition of the harness and connector.

NG >> Replace power seat switch.

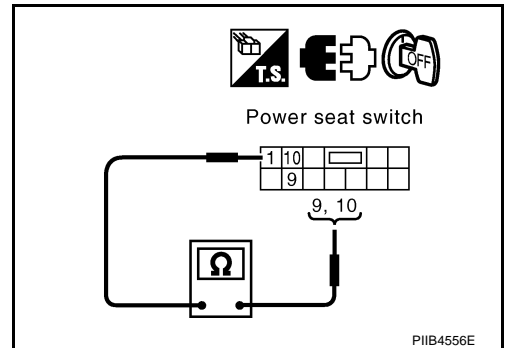

Check Passenger Side Door Switch

1. CHECK PASSENGER SIDE DOOR SWITCH SIGNAL

Check voltage between seat control unit connector B502 (passenger side) terminal 16 and ground.

Terminals		Condition	Voltage (V) (Approx.)
(+)	(-)		
16 (R/W)	Ground	Passenger side door: OPEN	0
		Passenger side door: CLOSE	Battery voltage

OK or NG

OK >> Door switch is OK.

NG >> GO TO 2.

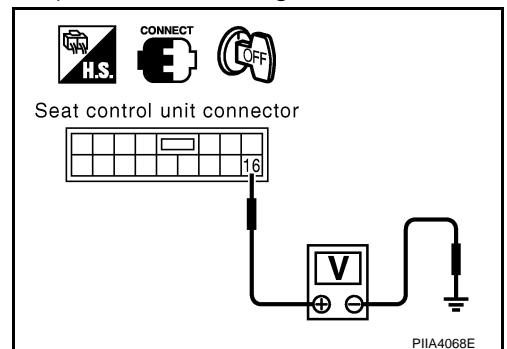

SUPPLEMENTAL RESTRAINT SYSTEM (SRS)

SUPPLEMENTAL RESTRAINT SYSTEM (SRS)

PPF:28556

SRS Configuration

NHS00011

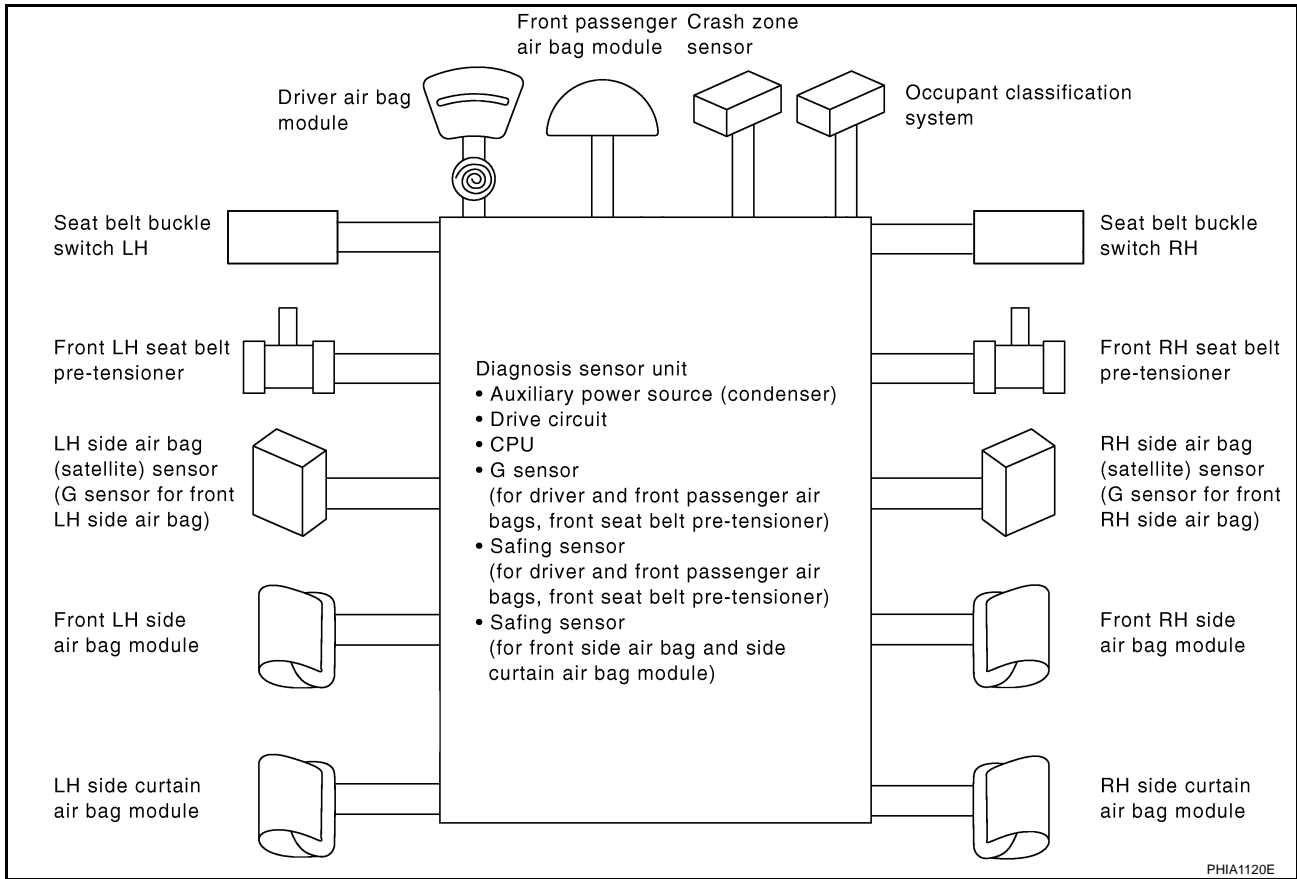

A

B

C

D

E

F

G

SRS

I

J

K

L

M

The air bag deploys if the diagnosis sensor unit activates while the ignition switch is in the ON or START position.

The collision modes for which supplemental restraint systems are activated are different among the SRS systems. For example, the driver air bag module and front passenger air bag module are activated in a frontal collision but not in a side collision.

SRS configurations which are activated for some collision modes are as follows:

SRS configuration	Frontal collision	Left side collision	Right side collision
Driver air bag module	×	—	—
Front passenger air bag module	×	—	—
Front LH seat belt pre-tensioner	×	—	—
Front RH seat belt pre-tensioner	×	—	—
Front LH side air bag module	—	×	—
Front RH side air bag module	—	—	×
LH side curtain air bag module	—	×	—
RH side curtain air bag module	—	—	×

TROUBLE DIAGNOSIS

<RH side air bag (Satellite) sensor>	
Flash pattern	Repair order
<p>a through f are repeated. f: Three flashes indicate malfunctioning RH side air bag (Satellite) sensor circuit.</p>	<ol style="list-style-type: none"> 1. Visually check the wiring harness connection. 2. Replace the harness if it has visible damage. 3. Replace the RH side air bag (Satellite) sensor. 4. Replace the diagnosis sensor unit. 5. Replace the related harness.

SHIA0032E

<LH side air bag (Satellite) sensor>	
Flash pattern	Repair order
<p>a through f are repeated. f: Four flashes indicate malfunctioning LH side air bag (Satellite) sensor.</p>	<ol style="list-style-type: none"> 1. Visually check the wiring harness connection. 2. Replace the harness if it has visible damage. 3. Replace the LH side air bag (Satellite) sensor. 4. Replace the diagnosis sensor unit. 5. Replace the related harness.

SHIA0033E

<Front RH side air bag module>	
Flash pattern	Repair order
<p>a through f are repeated. f: One flash indicates malfunctioning front RH side air bag module circuit.</p>	<ol style="list-style-type: none"> 1. Visually check the wiring harness connection. 2. Replace the harness if it has visible damage. 3. Replace the related harness.

PHIA1237E

<Front LH side air bag module>	
Flash pattern	Repair order
<p>a through f are repeated. f: Two flashes indicate malfunctioning front LH side air bag module circuit.</p>	<ol style="list-style-type: none"> 1. Visually check the wiring harness connection. 2. Replace the harness if it has visible damage. 3. Replace the related harness.

PHIA1238E

A
B
C
D
E
F
G
SRS
I
J
K
L
M

Fail-Safe Function

NGS00099

In the event there is a malfunction with the electrical system, the RAS control is stopped and the fail-safe mode is activated. At that time, it indicates the malfunction by turning the RAS warning lamp ON and stops the rear wheel control.

- A
- B
- C
- D
- E
- F
- STC**
- H
- I
- J
- K
- L
- M

Check RAS Static/Dynamic Characteristics**1. CHECK (1): RAS ACTUATOR STROKE**

Perform CONSULT-II "ACTIVE TEST", and then check the actuator stroke when turning the steering wheel clockwise or counterclockwise by 180° or more.

Neutral position (A)

Actuator stroke (B) : 2.8 - 3.0 mm (0.110 - 0.118 in)

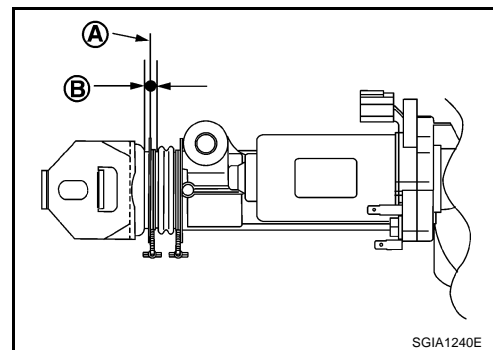
**OK or NG**

- OK >> GO TO 2.
NG >> GO TO 3.

2. CHECK (2): RAS ACTUATOR STROKE

Perform CONSULT-II "ACTIVE TEST". When turning the steering wheel in neutral position (A), the rear wheel turns clockwise/counterclockwise periodically. At that time, check actuator stroke (B).

Actuator stroke (B) : 2.3 - 2.5 mm (0.091 - 0.098 in)

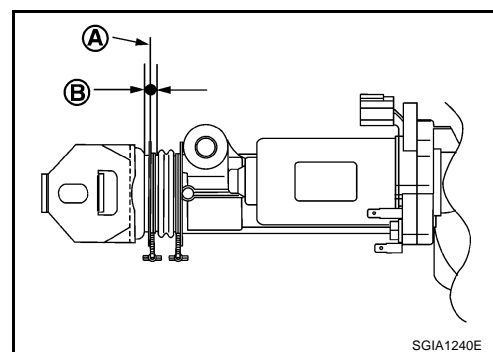
**OK or NG**

- OK >> RAS static/dynamic characteristics inspection is completed.
NG >> GO TO 3.

3. CHECK RAS MOTOR

Check RAS motor itself separated from other parts. Refer to [STC-44, "RAS MOTOR"](#) .

OK or NG

- OK >> GO TO 4.
NG >> RAS motor malfunction. Check the stroke again after replacing.

4. CHECK REAR WHEEL STEERING ANGLE SENSOR

Check rear wheel steering angle sensor separated from other parts. Refer to [STC-44, "REAR WHEEL STEERING ANGLE SENSOR"](#) .

OK or NG

- OK >> GO TO 5.
NG >> Rear wheel steering angle sensor malfunction. Check the stroke again after replacing.

5. CHECK RAS CONTROL UNIT

Replace RAS control unit. Check the symptom of malfunction again.

Is the malfunction corrected?

- YES >> RAS control unit malfunction
NO >> GO TO 6.

6. REPLACE RAS ACTUATOR ASSEMBLY

Replace RAS actuator assembly. Check the symptom of malfunction again.

Is the malfunction corrected?

- YES >> RAS actuator malfunction
NO >> Check rear suspension components. Refer to [RSU-7, "Components"](#) .

TROUBLE DIAGNOSIS

Control Unit Input/Output Signal Standard

NES00038

Standards using a circuit tester and oscilloscope

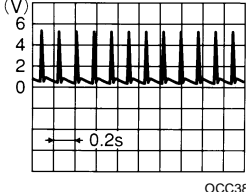
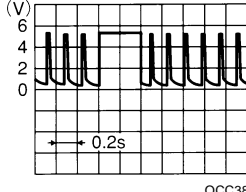
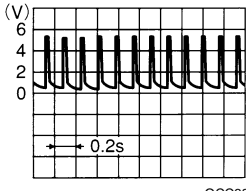
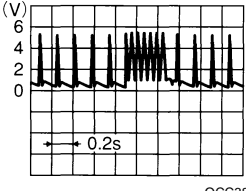
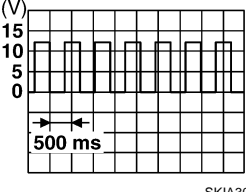
Terminal (Wire color)	Item	Condition	Voltage (V) Approx. value
15 (W)	Tire pressure warning check connector	Always	5 V
18 (B)	Remote keyless entry receiver (Ground)	—	0 V
19 (Y)	Remote keyless entry receiver (Power supply)	Stand-by	
		Press any of the keyfob switches	
20 (L)	Remote keyless entry receiver (Signal)	Stand-by	
		Press any of the keyfob switches	
38 (W/L)	Ignition switch	Ignition switch ON or START	Battery voltage (12 V)
39 (L)	Data line (CAN H)	—	—
40 (P)	Data line (CAN L)	—	—
42 (GY)	Battery power supply (Fuse)	Always	Battery voltage (12 V)
45 (G/W)	Turn signal (left)	<ul style="list-style-type: none"> ● Ignition switch ON ● Combination switch is turn signal (left) ON 	

A
B
C
D
WT
F
G
H
I
J
K
L
M

CLICK HERE TO **DOWNLOAD** THE COMPLETE MANUAL

- Thank you very much for reading the preview of the manual.
- You can download the complete manual from: www.heydownloads.com by clicking the link below



- Please note: If there is no response to CLICKING the link, please download this PDF first and then click on it.

CLICK HERE TO **DOWNLOAD** THE COMPLETE MANUAL