

Fuller Mid-Range Transmissions TRSM0190

October 2007

FS-8206A



BACKED BY
Roadranger
SUPPORT

CLICK HERE TO **DOWNLOAD** THE COMPLETE MANUAL

- Thank you very much for reading the preview of the manual.
- You can download the complete manual from: www.heydownloads.com by clicking the link below



- Please note: If there is no response to CLICKING the link, please download this PDF first and then click on it.

CLICK HERE TO **DOWNLOAD** THE COMPLETE MANUAL

TORQUE RECOMMENDATIONS

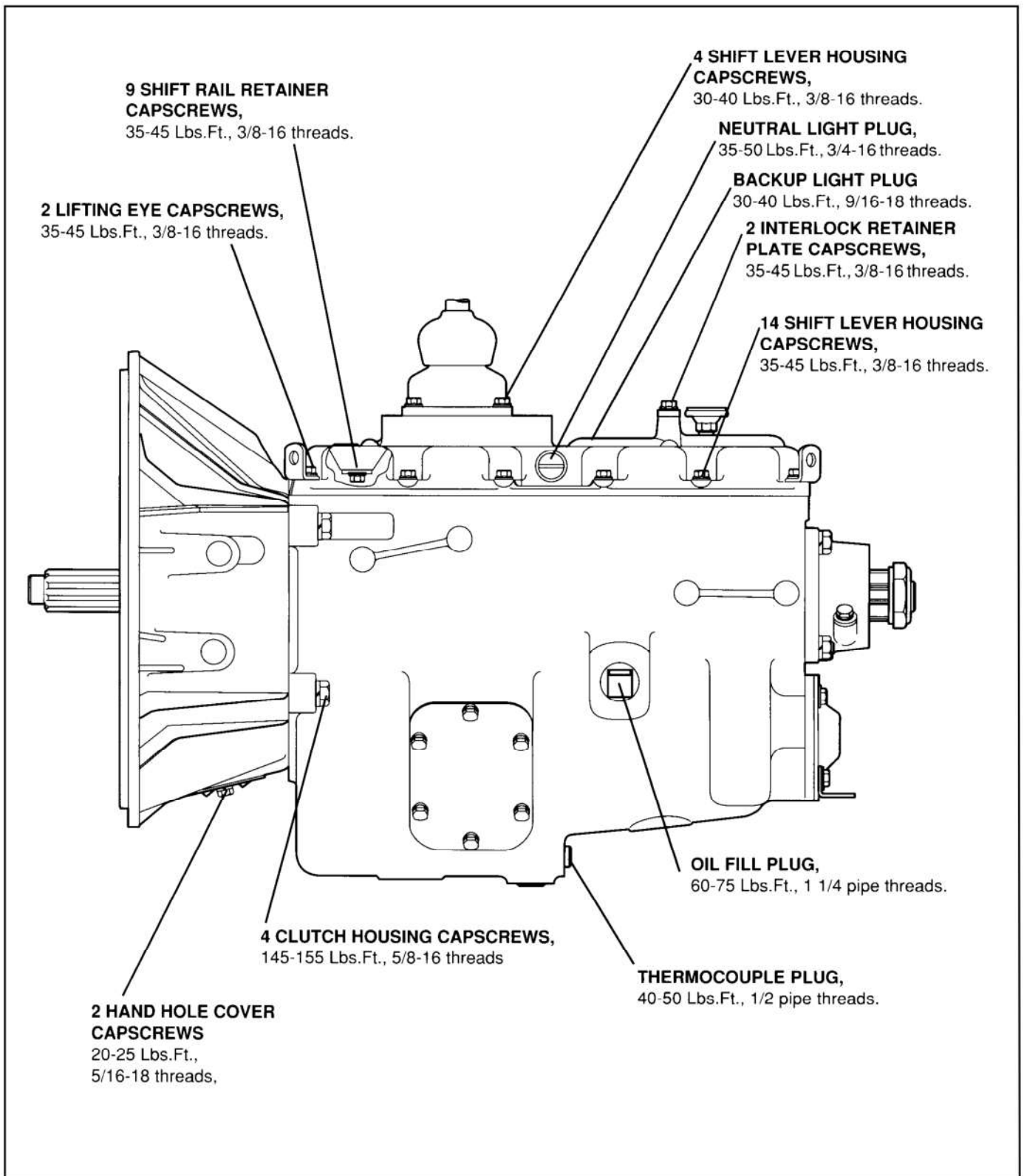

DISASSEMBLY AND REASSEMBLY SHIFTING CONTROLS

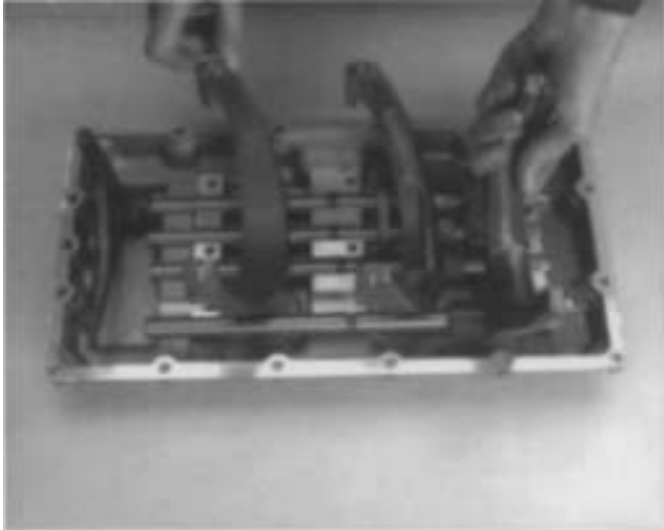

6. Remove the fifth-sixth yoke assembly from the shift bar housing and remove the interlock pin.

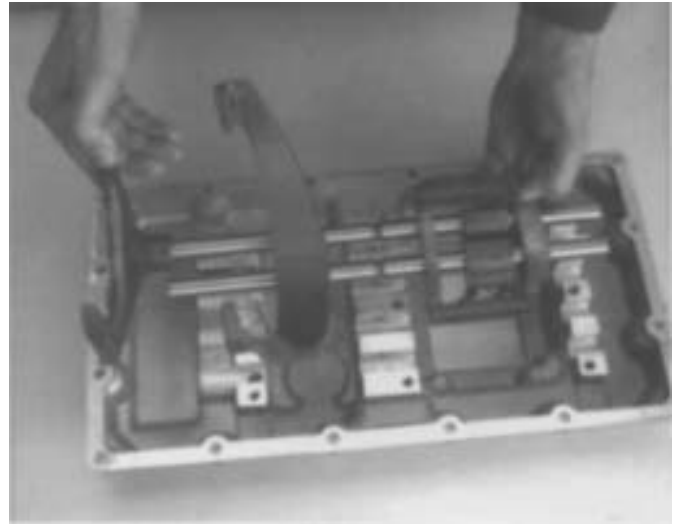

8. Remove the reverse, first-second yoke assembly from housing.

NOTE: Only first-second shift bar contains an interlock pin to be removed.

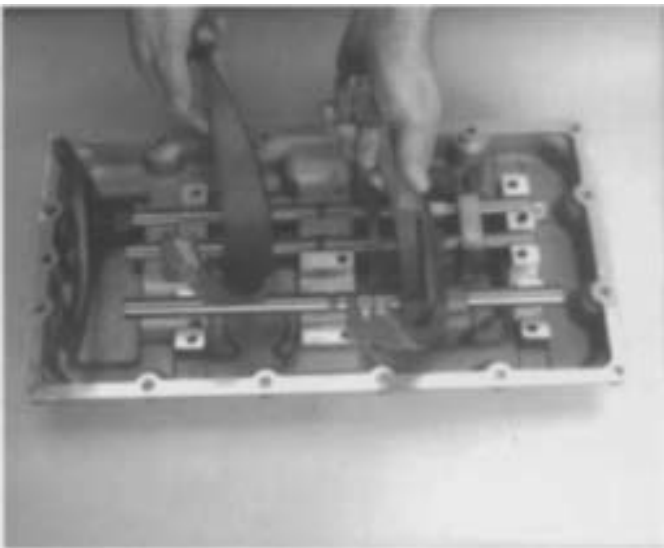

7. Remove the third-fourth yoke assembly and interlock pin.

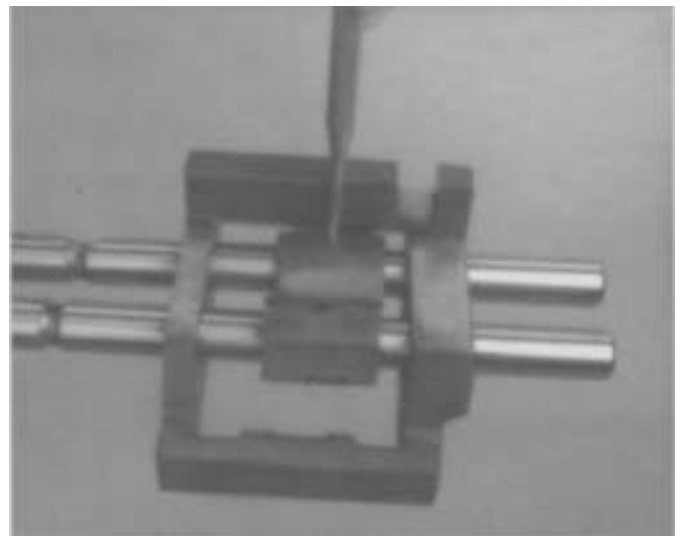

9. If replacement of fifth-sixth, first-second or reverse shift blocks is required, drive the roll pin from first-second and reverse shift blocks. This will allow all three shift blocks to be removed from the first-second and reverse shift bars.

DISASSEMBLY - TRANSMISSION



3. Wrap a sling around the third-fourth synchronizer assembly. Use a hoist to remove the mainshaft assembly from the case. Remove the reverse gear sliding clutch from the mainshaft (inset).

NOTE: When removing mainshaft, countershaft must be secured forward to allow removal of mainshaft assembly. This procedure must also be followed during reassembly.



4. Install the mainshaft assembly in a vise equipped with soft jaws or wood, front of shaft facing up. Remove the fifth-sixth speed synchronizer assembly and synchronizer cups from the mainshaft.

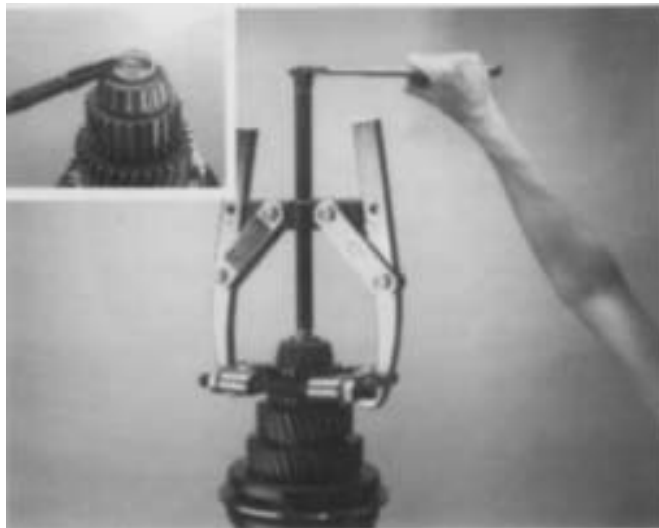

5. Remove retaining snap ring from front of shaft (inset) using a puller and clamp mounted behind fifth-sixth speed shift hub, remove the shift hub and bearing.



6. Remove the sixth speed or overdrive gear and bearings (inset) from the mainshaft.

REASSEMBLY - TRANSMISSION

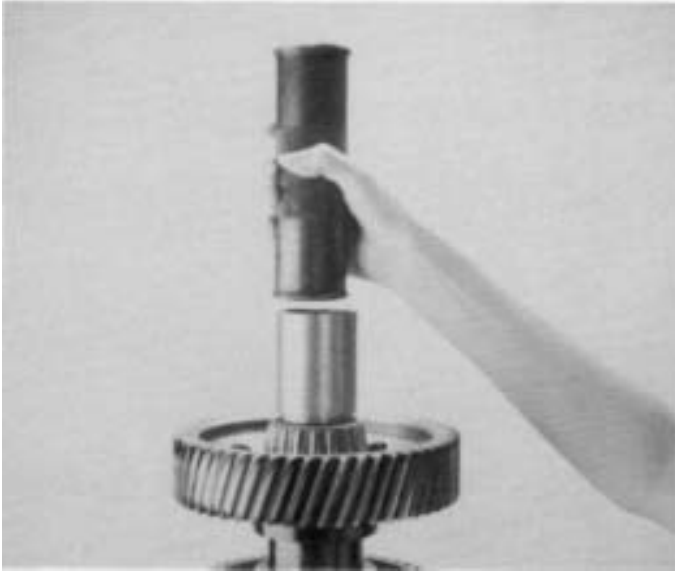

6. Using the proper size bearing driver, install the countershaft front bearing on the countershaft front.

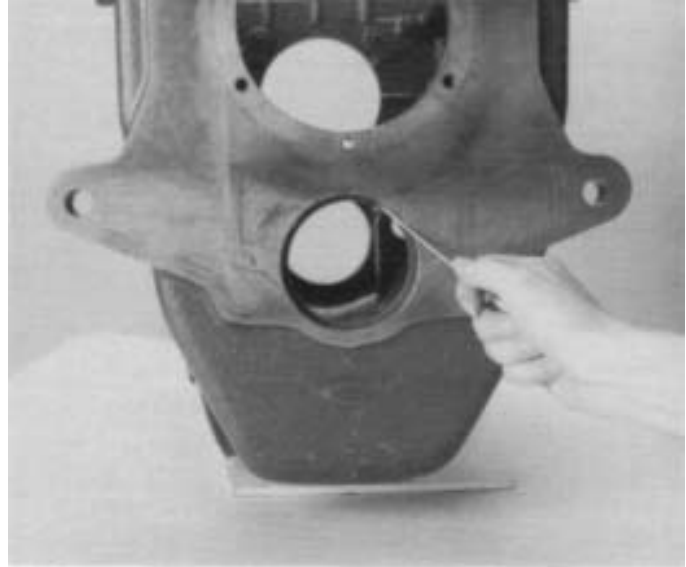

8. If previously removed, install the countershaft front bearing race snap ring in the case.



7. Using the proper size bearing driver, install the countershaft rear bearing on the countershaft rear. Make sure the bearing is seated against the countershaft.

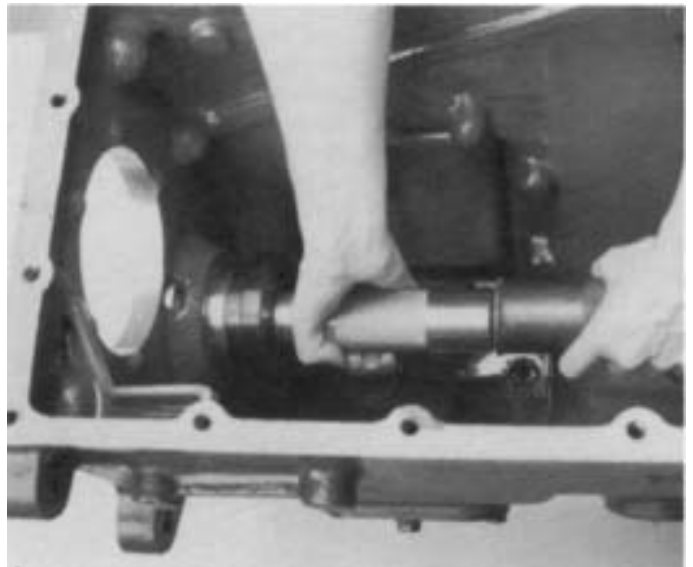

9. With the proper size bearing driver, install the countershaft front bearing race in the countershaft front bearing bore and against the retaining snap ring.

REASSEMBLY - TRANSMISSION



24. Install new input shaft bearing race in the front bearing cover (left). Install front bearing cover oil seal. Seat oil seal in cover bore with proper flanged driver (right).

NOTE: Care must be taken when installing the seal. Improper installation will damage seal.



25. Install the front bearing cover, gasket and align the six capscrews to the front of the transmission case.

NOTE: Check the alignment of the front bearing cover, make sure oil passage in cover aligns with oil passage in front of transmission case. Bearing cover may be marked (top).

C. Installation of Rear Bearing Cover and Mainshaft Shimming Procedure



1. To service the O-ring on the spin shim remove and replace the O-ring. Apply Fuller #71206 silicone lubricant when reinstalling the O-ring.

NOTE: Install speedometer driver gear or rotor on output shaft at this time.

NOTE: Turn the spin shim out counterclockwise prior to installation of the rear bearing cover assembly to ease installation.



2. Clean the rear case surface and rear bearing cover surface before installing the rear bearing cover assembly, no shims are installed at this time.

NOTE: Turn the spin shim in clockwise to properly align the rear bearing cover assembly to the case bore.

CLICK HERE TO **DOWNLOAD** THE COMPLETE MANUAL

- Thank you very much for reading the preview of the manual.
- You can download the complete manual from: www.heydownloads.com by clicking the link below



- Please note: If there is no response to CLICKING the link, please download this PDF first and then click on it.

CLICK HERE TO **DOWNLOAD** THE COMPLETE MANUAL