





<--- CLICK BOOKMARKS TO OPEN MENU

Shop
Manual

2006

4-TEC™ Series

CLICK HERE TO **DOWNLOAD** THE COMPLETE MANUAL

- Thank you very much for reading the preview of the manual.
- You can download the complete manual from: www.heydownloads.com by clicking the link below



- Please note: If there is no response to **CLICKING** the link, please download this PDF first and then click on it.

CLICK HERE TO **DOWNLOAD** THE COMPLETE MANUAL

Section 01 MAINTENANCE
Subsection 01 (MAINTENANCE CHART)

MAINTENANCE CHART

The schedule should be adjusted according to operating conditions and use.

NOTE: The chart gives an equivalence between number of hours and months/year. Perform the maintenance operation to whatever time comes first.

IMPORTANT: Watercraft rental operations or intensive use of watercraft, will require greater frequency of inspection and maintenance.

4-TEC MODELS						
A: ADJUST C: CLEAN I: INSPECT L: LUBRICATE R: REPLACE	FIRST 10 HOURS					
	EVERY 25 HOURS OR 3 MONTHS					
	EVERY 50 HOURS OR 6 MONTHS					
	EVERY 100 HOURS OR 1 YEAR					
	EVERY 200 HOURS OR 2 YEAR					
PART/TASK	REFER TO					
GENERAL						
Corrosion protection			L		STORAGE PROCEDURE	
ENGINE						
Engine oil and filter (including cover's O-rings)	R			R ⁽¹⁾	LUBRICATION SYSTEM	
Rubber mounts	I			I	ENGINE REMOVAL AND INSTALLATION	
Exhaust system fasteners ⁽²⁾	I			I	EXHAUST SYSTEM	
Exhaust system flushing				⁽³⁾ (7)		
Supercharger slipping moment (if so equipped)				I	SUPERCHARGER	
COOLING SYSTEM						
Hose and fasteners	I				COOLING SYSTEM	
Coolant	I			R		
FUEL SYSTEM						
Throttle cable	I			I ⁽⁵⁾	ENGINE MANAGEMENT	
Fuel injection system sensors	I			I		
Throttle position sensor (TPS) ⁽²⁾	I			I		
Throttle body (IMPORTANT: see ⁽⁴⁾)	I			L	ENGINE MANAGEMENT and STORAGE PROCEDURES	
Fuel lines, connections, pressure relief valve and fuel system leak test ⁽²⁾	I			I	FUEL TANK AND FUEL PUMP	
Fuel tank straps	I			I		
AIR INTAKE SYSTEM						
Air intake silencer fit/tightness	I			I	AIR INTAKE SYSTEM	
ELECTRICAL SYSTEM						
Spark plug ⁽²⁾	I			I	R	IGNITION SYSTEM
Electrical connections and fastening (ignition system, starting system, fuel injectors etc.)	I			I		ELECTRICAL SYSTEM
MPEM and ECM connectors (visual inspection without disconnecting)				I ⁽⁶⁾		ENGINE MANAGEMENT
EMS fault code reading ⁽²⁾	I			I		DIGITALLY ENCODED SECURITY SYSTEM
Digitally Encoded Security System (DESS) and safety lanyard/post	I			I		
Monitoring beeper	I			I		GAUGE, SENSORS AND FUSES
Battery and fasteners	I			I		CHARGING SYSTEM

Section 01 MAINTENANCE

Subsection 04 (SPECIAL PROCEDURES)

- Fill up the reservoir with fresh oil.
- Proceed with the boil out procedure below.

Boil Out Procedure

NOTE: This procedure is intended to evaporate the water contained in the oil. The procedure with the watercraft in water is the preferred one, but it can also be done using the flush kit.

Procedure in a Test Tank or Tied to a Trailer with Watercraft in Water

- Connect the vehicle to B.U.D.S. to monitor the coolant temperature. It must exceed 100°C (212°F) in order for the water boil out. Once the boil point is reached, it won't take long to evaporate the water.
- Run the engine for 5 minutes at 3500 RPM.

⚠ WARNING

Make sure to safely secure the watercraft.

- With the engine still running at 3500 RPM, install a hose pincher to the coolant line going to the oil cooler.

⚠ WARNING

Certain components in the engine compartment may be very hot. Direct contact may result in skin burn. Do not touch any electrical parts or jet pump area when engine is running.

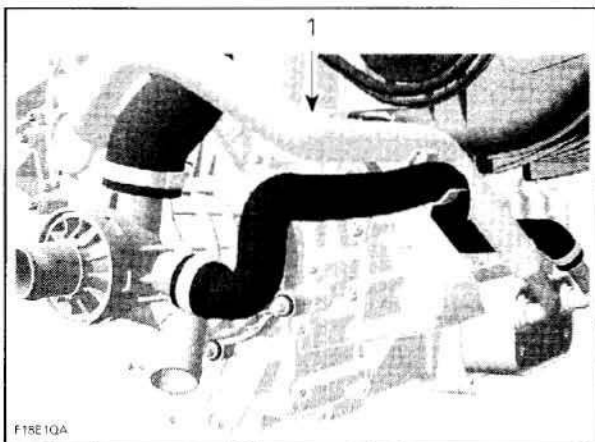

1. Oil cooler coolant inlet hose

- Continue to run the engine at 3500 RPM for 15 more minutes (20 minutes total run time).
- Shut the engine off.
- Remove the hose pincher on the coolant line going to the oil cooler.

CAUTION: Hose pincher must be removed prior to operating the watercraft. Failure to do this will result in damage to the engine.

- Change the oil and filter again.
- Procedure is now completed.

Procedure Connected to a Flush Kit

- On drive shaft, remove the C-clip then move forward the ring seal carrier. Refer to *DRIVE SYSTEM* section.

CAUTION: Make sure that the ring seal carrier is not in contact with the PTO seal assembly, neither with the carbon ring.

- Connect the vehicle to B.U.D.S. to monitor the coolant temperature. It must exceed 100°C (212°F) in order for the water boil out. Once the boil point is reached, it won't take long to evaporate the water.
- Connect a flush kit to the coolant line.

CAUTION: Never run engine without supplying water to the exhaust cooling system when watercraft is out of water.

- Run the engine for 5 minutes at 3000 RPM.
- With the engine still running at 3000 RPM, install a hose pincher to the coolant line going to the oil cooler.

⚠ WARNING

Certain components in the engine compartment may be very hot. Direct contact may result in skin burn. Do not touch any electrical parts or jet pump area when engine is running.

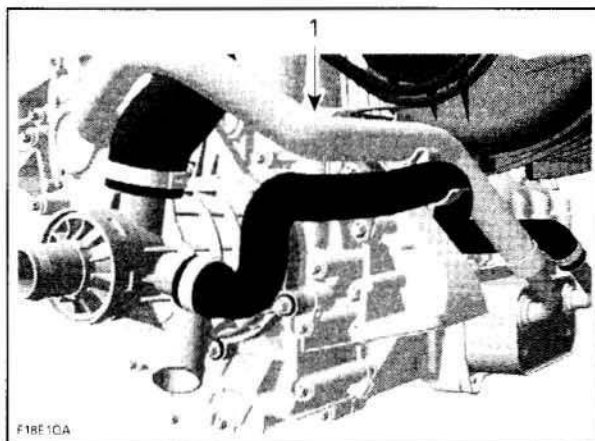

1. Oil cooler coolant inlet hose

- Continue to run the engine at 3000 RPM for 15 more minutes (20 minutes total run time).
- Shut off the engine.

Section 02 TROUBLESHOOTING
Subsection 01 (TROUBLESHOOTING CHART)

Symptom: **LOW OR NO ENGINE OIL PRESSURE** (cont'd)

- 3. Oil leaking out of leak indicator hole (PTO housing)**
- Replace oil seal on pump shaft.
- 4. Oil pressure sensor defective**
- Check/replace.
- 5. Oil pump malfunctioning**
- Clean rotor and check wear limits.
- 6. Oil regulator valve sticks open, or spring load too small**
- Clean/replace.
- 7. Heavy wear on plain bearings**
- Replace.

Symptom: **ENGINE OIL CONTAMINATION (milky)**

- 1. Oil seal and rotary seal on coolant pump shaft leaking**
- Replace both seals. Refer to PTO HOUSING AND MAGNETO. Change oil.
- 2. Cylinder head gasket leaking**
- Replace gasket. Refer to CYLINDER HEAD. Change oil.
- 3. Loose screws on cylinder head, PTO housing or oil separator**
- Retorque. Change oil.
- 4. Oil contamination due to metal or plastic particles**
- Replace possibly damaged parts. Change oil.
- 5. Water ingestion (intake manifold, TOPS valve, dipstick)**
- Refer to MAINTENANCE.
- 6. Leak indicator hole plugged**
- Check/clean leak indicator hole.

Symptom: **UNUSUAL ENGINE NOISE AND/OR VIBRATION**

- 1. Worn chain tensioner**
- Replace.
- 2. Worn chain guide**
- Replace.
- 3. Stretched chain and/or worn out sprockets**
- Replace chain and sprockets.
- 4. Sprocket screws got loose**
- Retorque.
- 5. Hydraulic element inside rocker arm(s) is worn out (valve adjustment) or lifter damaged**
- Replace faulty rocker arm(s) and/or lifters.
- 6. Rocker arm screws not tightened**
- Retorque.
- 7. Heavy wear on crankshaft and/or balancer shaft bearings**
- Replace.
- 8. Crankshaft and balancer shaft not aligned**
- Check marks and readjust shafts.

Section 03 ENGINE
Subsection 01 (ENGINE REMOVAL AND INSTALLATION)



TYPICAL
1. Shim

Remove engine support screws and apply Loctite 243 (blue) (P/N 293 800 060) on screw threads. Torque engine support screws to 25 N•m (18 lbf•ft) when procedure is completed.

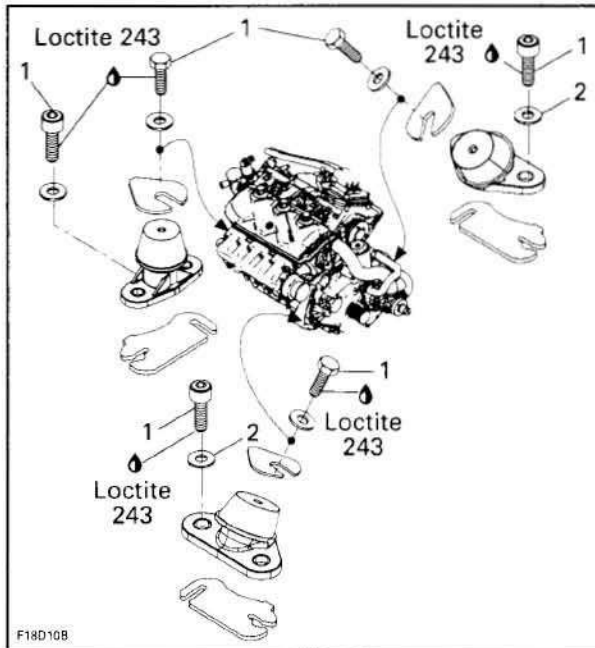

1. Torque to 25 N•m (18 lbf•ft)
2. Position washer to have the "T" mark on top

Remove alignment tools.

Section 03 ENGINE
Subsection 04 (INTAKE MANIFOLD AND INTERCOOLER)

Supercharged Engine

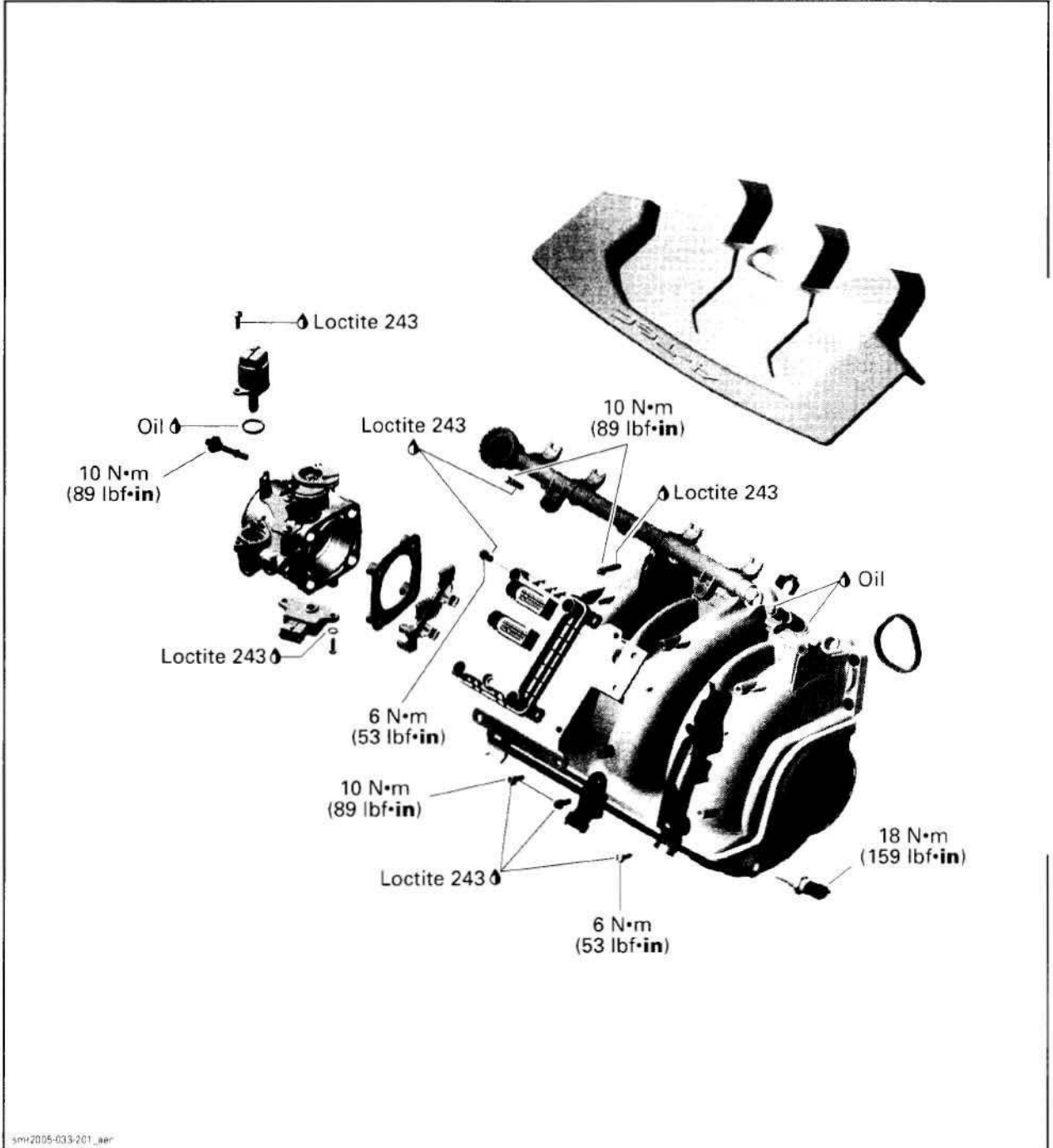

SUPERCHARGER

SERVICE TOOLS

Description	Part Number	Page
4-pin socket	529 035 948	59, 61
camshaft locking tool.....	529 035 839	55
gear holder	529 036 025	64
retaining key	529 036 027	57-58, 63
support plate.....	529 035 947	60-61
support/pusher	529 035 950	60-61
Torx adapter	529 035 938	56, 65

SERVICE PRODUCTS

Description	Part Number	Page
Kluber Isoflex grease	293 550 021	63
Loctite 243.....	293 800 060	61-63, 65
Loctite 5910.....	293 800 081	63
Super Lube grease	293 550 030	64

Section 03 ENGINE

Subsection 05 (SUPERCHARGER)

Apply heat outside of the housing with a heat gun to expand its diameter prior to inserting the shaft. Ensure there is no O-ring on the housing half prior to heating.

Apply engine oil on supercharger shaft. Press shaft with thrust washer and distance sleeve together in supercharger housing half.

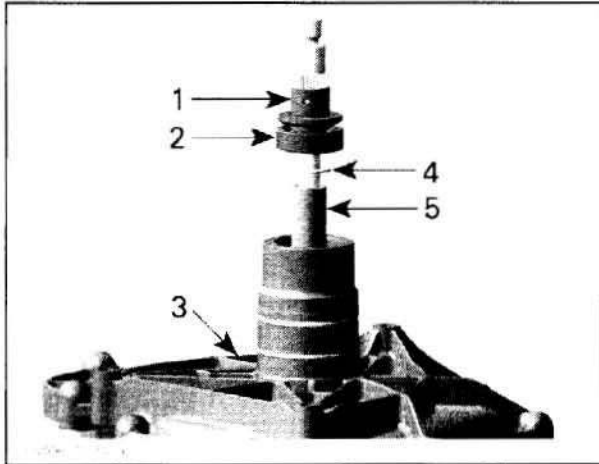

- 1 Compressor shaft
- 2 Ball bearing
- 3 Supercharger housing half
- 4 Thrust washer
- 5 Distance sleeve

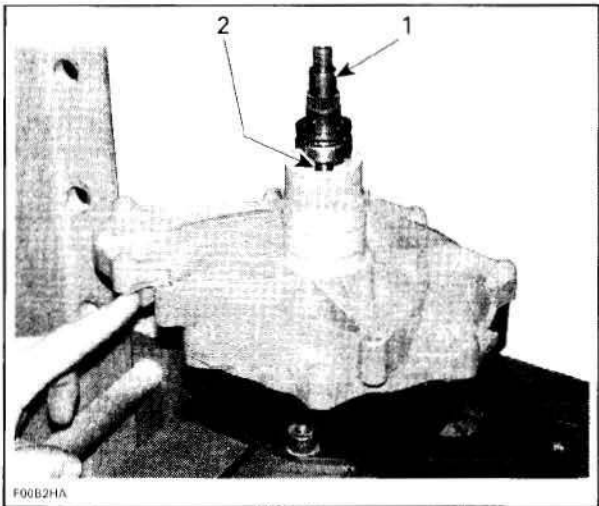

- 1 Supercharger shaft
- 2 Distance sleeve

Apply engine oil on seal and push into retaining disc by hand.

NOTE: Always use a new oil seal when assembling the supercharger.

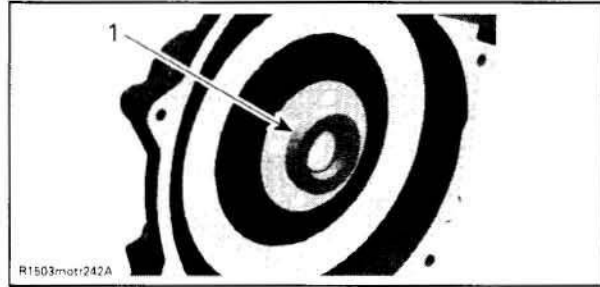

- 1 Oil seal

Install step collar, O-ring, supercharger impeller and washer on supercharger shaft. Apply Loctite 243 (P/N 293 800 060) on cap nut and temporary finger tight cap nut.

NOTE: The cap nut on the supercharger shaft has a left-handed thread. The Loctite has to be applied in a small dose into the nut.

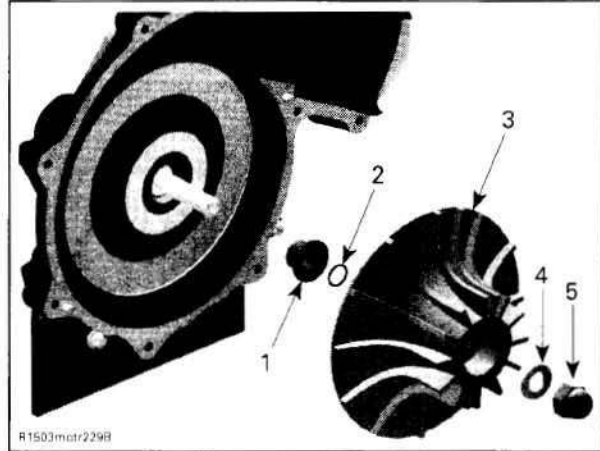

- 1 Step collar
- 2 O-ring
- 3 Supercharger impeller
- 4 Washer
- 5 Cap nut

Complete installation of supercharger shaft, engine side as follows:

CAUTION: It is of the utmost importance that all parts be absolutely clean. The compressor shaft spins at up to 45 000 RPM and any debris could cause a failure.

Install the first ceramic washer.

NOTE: The ceramic washers differ in their inner diameter. Install first the ceramic washer with the bigger inner diameter. The ceramic washer with the smaller inner diameter will be installed on the lock washer side.

CAUTION: Manipulate ceramic washers with care, those parts are fragile.

Section 03 ENGINE
Subsection 06 (EXHAUST SYSTEM)

Run the engine about 20 seconds at a fast idle between 4000 - 5000 RPM.

CAUTION: Never run engine longer than 2 minutes. Drive line seal has no cooling when watercraft is out of water.

Ensure water flows out of jet pump while flushing. Close the water tap, then stop the engine.

CAUTION: Always close the water tap before stopping the engine.

Disconnect the garden hose.

CAUTION: Remove flushing connector adapter after operation (if used).

Procedure Using Flushing Connector in Engine Compartment

GTX Limited Models

This flushing connector allows to flush the exhaust system directly by the engine compartment. The access is easier than the connector on the jet pump support but requires the use of a small hose pincher.

Remove seat to gain access.

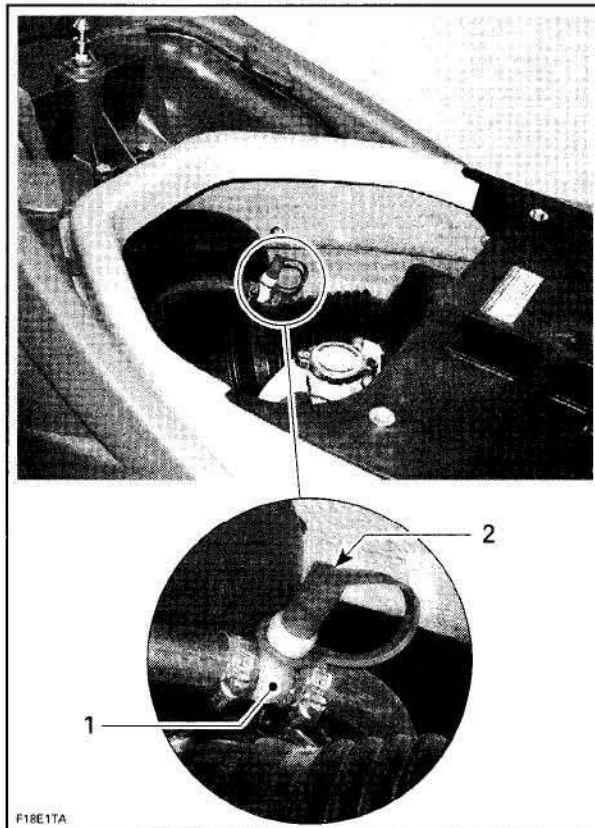

1. Flushing connector
2. Dust cap

Remove dust cap from flushing connector and attach coupler hose (supplied with vehicle). Make sure coupler hose is properly locked to flushing connector.

Install a small hose pincher (P/N 295 000 076) (supplied inside vehicle tool kit) on water outlet hose. This prevent water from directly existing exhaust cooling system.

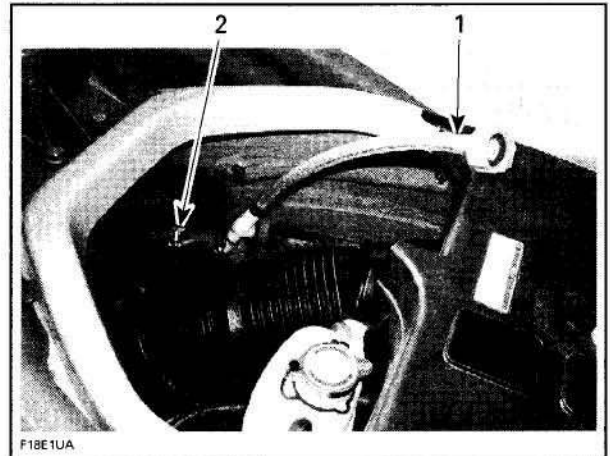
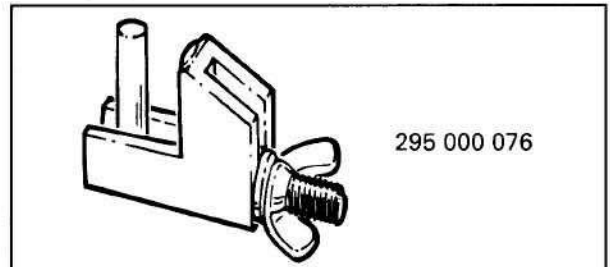

1. Coupler hose
2. Small hose pincher

Attach other end of coupler hose to a garden hose. Do not open water tap yet.

To flush the exhaust cooling system, start the engine then immediately open the water tap.

CAUTION: Always start the engine before opening the water tap. Open water tap immediately after engine is started to prevent overheating.

CAUTION: Never run engine without supplying water to the exhaust system when watercraft is out of water.

Run the engine about 20 seconds at a fast idle between 4000 - 5000 RPM.

CAUTION: Never run engine longer than 2 minutes. Drive line seal has no cooling when watercraft is out of water.

Ensure water flows out of jet pump while flushing. Close the water tap, then stop the engine.

Section 03 ENGINE

Subsection 07 (PTO HOUSING AND MAGNETO)

PTO Housing Removal

Place rags under PTO housing to prevent spillage. Up to 250 mL (8 oz) of oil could flow out when removing PTO housing. If spillage occurs, clean immediately with the pulley flange cleaner (P/N 413 711 809) to prevent oil stains.

Disconnect CPS and magneto from wiring harness.

⚠ WARNING

Always disconnect battery or starter cables exactly in the specified order, **BLACK** negative cable first. Disconnect electrical connections prior to disconnecting fuel lines.

Slightly lift rear part of engine and safely block in this position. Remove rear LH side engine support no. 1.

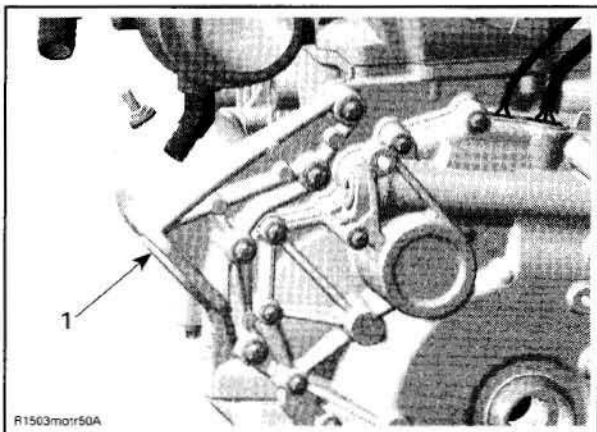

TYPICAL
1. Engine support

Remove:

- thru-hull fitting boot

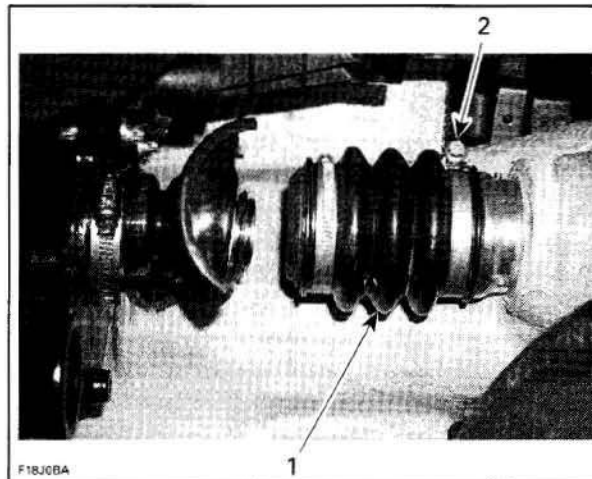

1. Thru-hull fitting boot
2. Remove this collar

- water pump housing no. 2 (refer to *COOLING SYSTEM*)
- unplug CPS connector
- screws no. 3 and no. 4

NOTE: Carefully separate the PTO housing from the engine using two flat screwdrivers prying equally at the same time. Proceed slowly so that starter gear disc springs no. 6 and washer no. 7 do not fall down.

- PTO housing no. 5

CAUTION: Ensure to use prying lugs to separate PTO housing to prevent damaging contact surface.

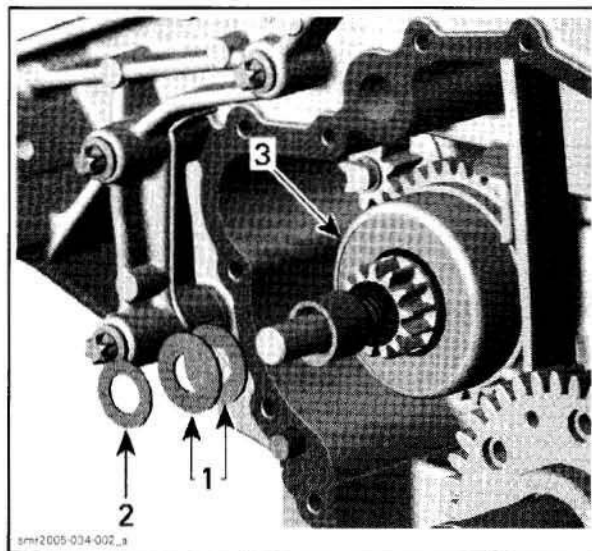

1. Disc springs
2. Washer
3. Starter drive gear

- gasket no. 9.

Section 03 ENGINE
Subsection 08 (LUBRICATION SYSTEM)

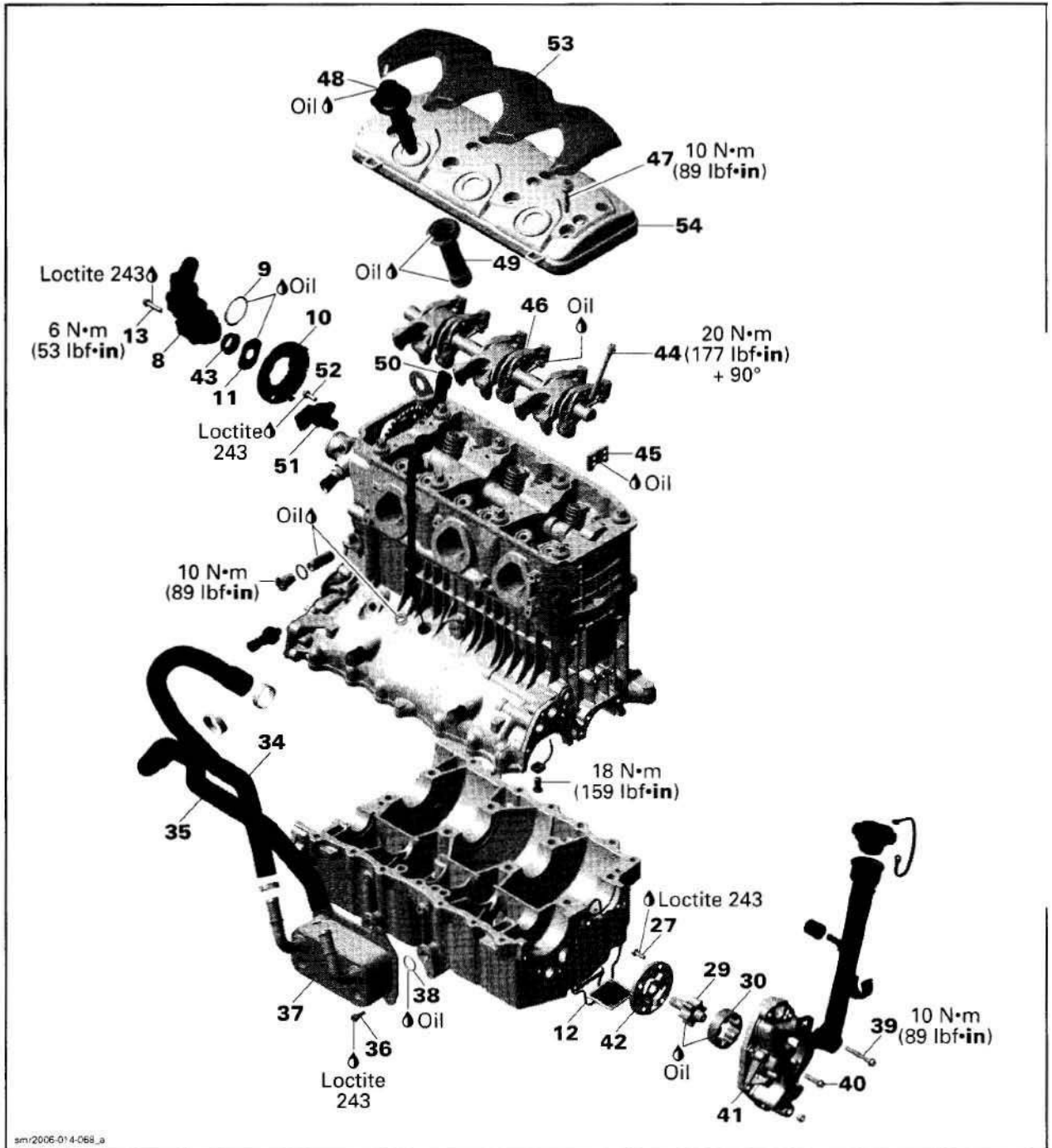

Section 03 ENGINE
Subsection 08 (LUBRICATION SYSTEM)

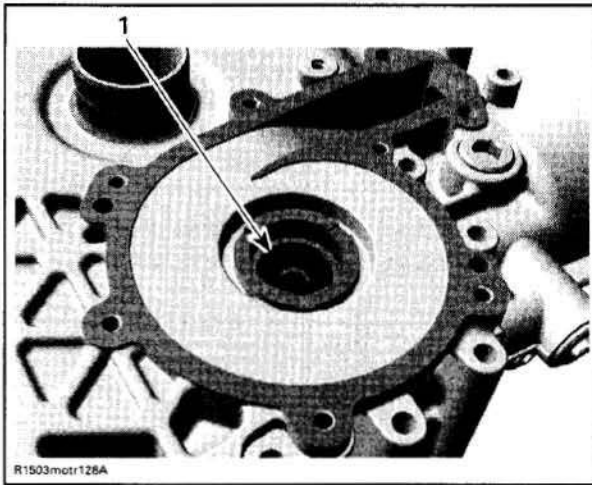

1. Oil seal

Install the new rotary seal by using the rotary seal pusher (P/N 529 035 823).

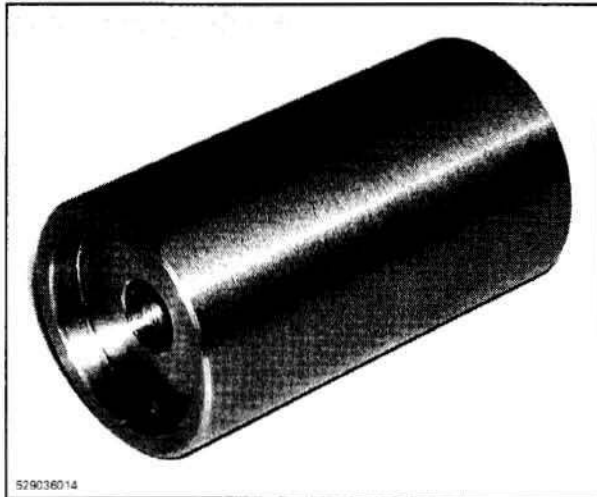

CAUTION: Never use a hammer for the rotary seal or water/oil pump shaft installation. Only use a press to avoid damaging the ceramic component.

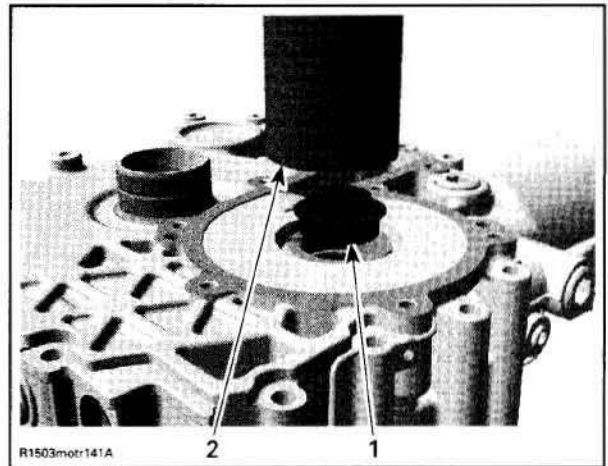

TYPICAL
 1. Rotary seal
 2. Rotary seal pusher

Install the water/oil pump shaft using the rotary seal pusher (P/N 529 035 823) on the opposite side to support the rotary seal. Use the oil seal guide (P/N 529 035 822) with a press.

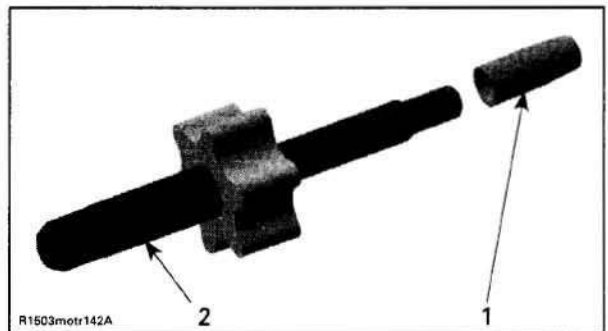

1. Oil seal guide
 2. Water/oil pump shaft

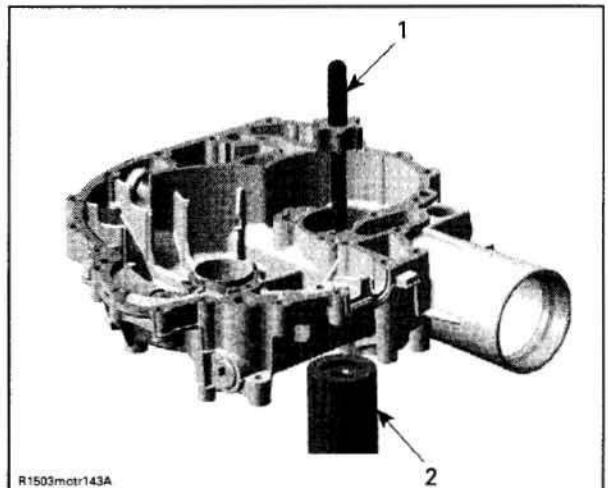

1. Water/oil pump shaft with oil seal guide
 2. Rotary seal pusher

GENERAL

CIRCUIT

A closed loop cooling system is utilized on the 1503 4-TEC engines, which offers an efficient engine cooling while keeping dirt and salt water out of the cooling system. This system keeps the temperature constant and prevents internal engine corrosion.

A separate coolant expansion tank ensures that enough engine coolant is in the circuit during any operating condition.

The coolant flow comes from the water pump impeller into the cylinder block. It goes around the cylinders and straight up to the cylinder head. A smaller quantity of engine coolant enters the cylinder block on the exhaust side for a better cooling. In the cylinder head the water channels flow around the exhaust and then the intake valves and leave the engine through a large hose. From there the coolant goes back to the water pump housing and depending on the engine temperature, it flows through the thermostat directly back to the water pump impeller, or it takes its way through the ride plate which operates as a heat exchanger.

Engine coolant is also directed towards the oil cooler (coolant type).

Coolant temperature sensor and bleed nipple are located on the cylinder head.

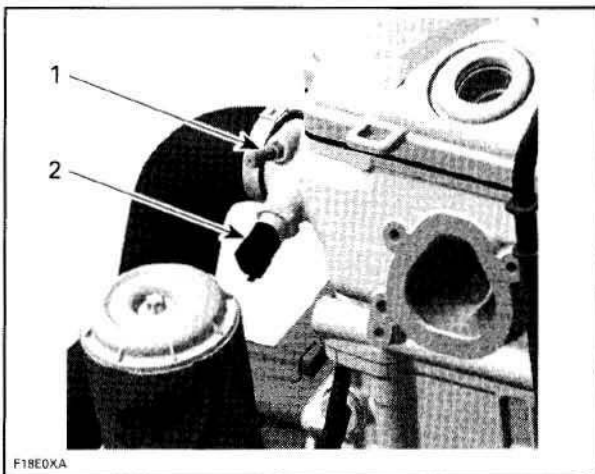

1. Bleed nipple
 2. Coolant temperature sensor (CTS)

CAUTION: Never modify cooling system arrangement, otherwise serious engine damage could occur.

TECHNICAL SPECIFICATIONS

TYPE	Closed loop cooling system.
COOLANT FLOW	Flow from water pump.
TEMPERATURE CONTROL	Thermostat.
SYSTEM BLEEDING	Self-bleed type through expansion tank (hose at uppermost point of circuit).
MONITORING BEEPER	Turns on at 100°C (212°F) on naturally aspirated engines. Turns on at 110°C (230°F) on supercharged engines.
COOLANT LIFE CYCLE	100 hours or 1 year. Should be replaced before storage.

INSPECTION

PRESSURE CAP

Using a pressure cap tester, check pressure cap efficiency. If the efficiency is feeble, install a new 90 kPa (13 PSI) cap (do not exceed this pressure).

HOSES AND CLAMPS

Check general condition of hoses and clamp tightness.

COOLING SYSTEM LEAK TEST

⚠ WARNING

To avoid potential burns, do not remove the expansion tank cap or loosen the ride plate drain plug if the engine is hot.

Install the test cap (P/N 529 035 991).

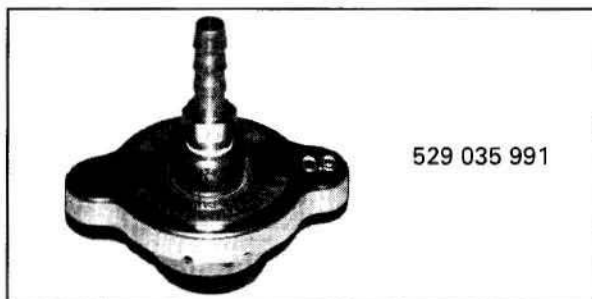

NOTE: It is not necessary to install a hose pincher on overflow hose.

Section 03 ENGINE
Subsection 10 (CYLINDER HEAD)

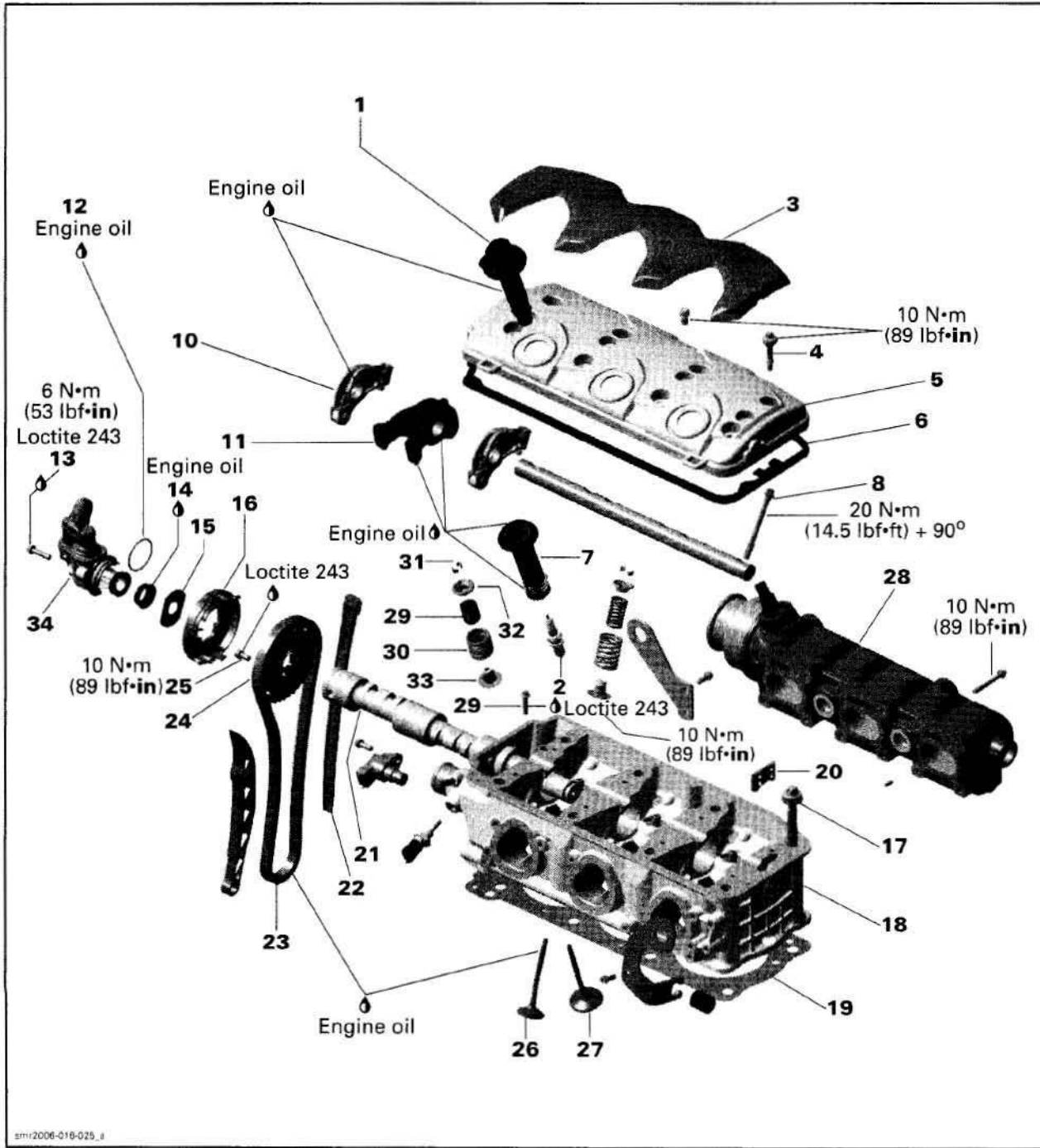

Section 03 ENGINE
Subsection 10 (CYLINDER HEAD)

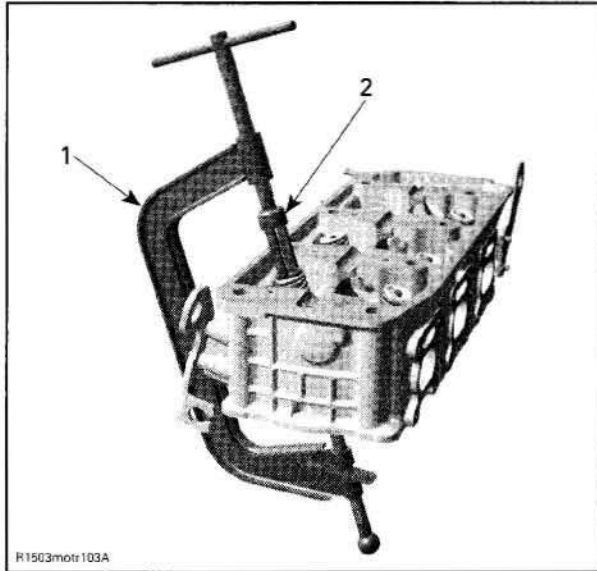

R1503motr103A

1. Valve spring compressor clamp
2. Valve spring compressor cup

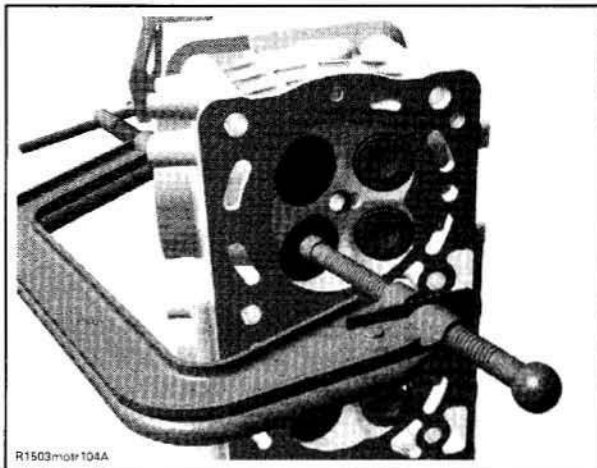

R1503motr104A

LOCATE VALVE SPRING COMPRESSOR CLAMP IN CENTER OF THE VALVE

Remove valve cotters no. 31.
 Withdraw valve spring compressor, valve spring retainer no. 32 and valve springs.

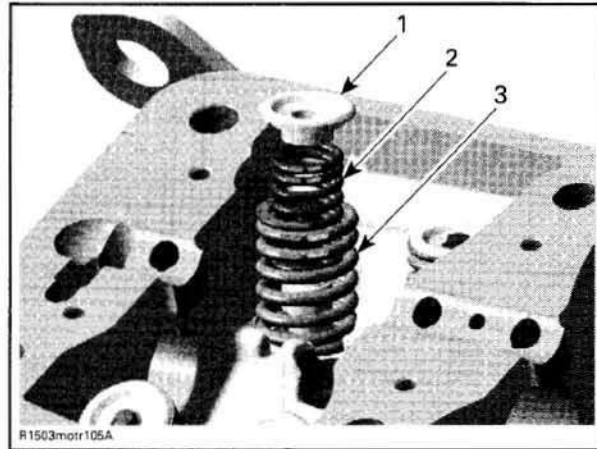

R1503motr105A

1. Valve spring retainer
2. Inner valve spring
3. Outer valve spring

Inspection

Check valve springs for rust, corrosion or other visible damages. If so, replace faulty valve springs.
 Check valve springs for free length and straightness.

Replace valve springs if not within specifications.

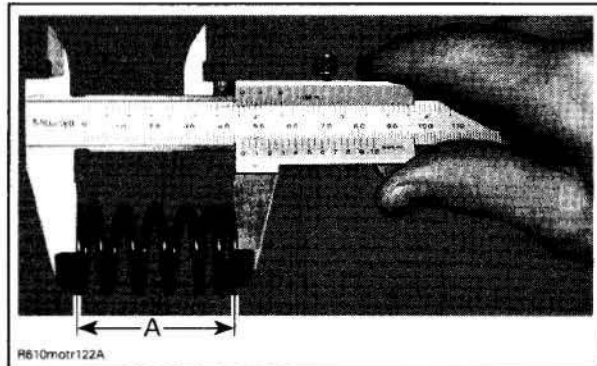

R610motr122A

A. Valve spring length

OUTER VALVE SPRING FREE LENGTH	
NEW NOMINAL	45.45 mm (1.789 in)
SERVICE LIMIT	43 mm (1.693 in)
INNER VALVE SPRING FREE LENGTH	
NEW NOMINAL	41.02 mm (1.615 in)
SERVICE LIMIT	38.8 mm (1.499 in)

Installation

For installation, reverse the removal procedure. Pay attention to the following details.

Colored area of the valve spring must be placed on top.

PISTON/CONNECTING ROD

Removal

Disassemble cylinder block as per procedure in this section. Refer to *CYLINDER BLOCK*.

NOTE: It is recommended to measure connecting rod big end axial play prior to remove connecting rod. Refer to *INSPECTION* below.

Remove connecting rod cap screws.

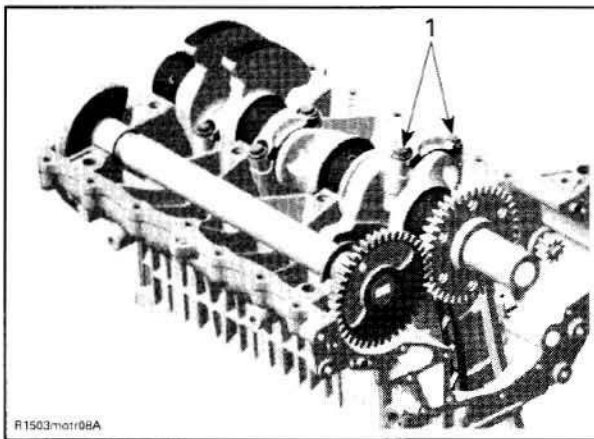

1. Connecting rod screws

NOTE: Before removing the connecting rod caps, mark them to remember the right position when reassembling.

Pull piston with connecting rod out of the cylinders.

Remove one piston circlip no. 8 and discard it.

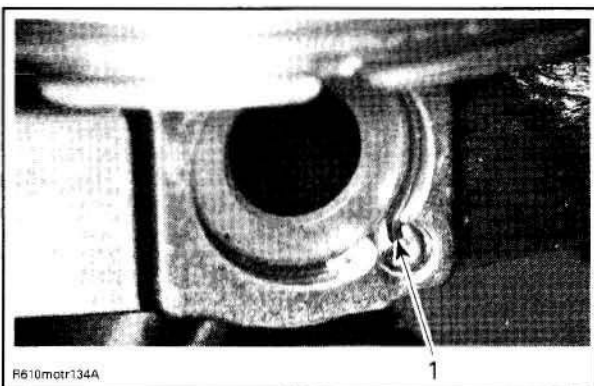

1. Piston circlip

NOTE: The removal of both piston circlips is not necessary to remove piston pin.

Push piston pin no. 9 out of piston.

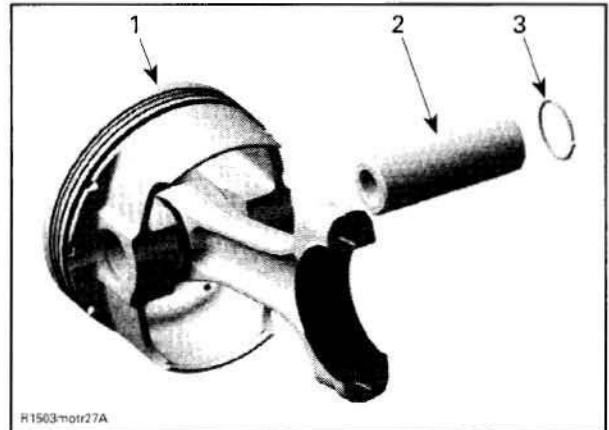

1. Piston
2. Piston pin
3. Circlip

Detach piston no. 10 from connecting rod.

Inspection

Connecting Rod Big End Axial Play

Using a feeler gauge, measure distance between butting face of connecting rod and crankshaft counterweight. If the distance exceeds specified tolerance, replace the worn part.

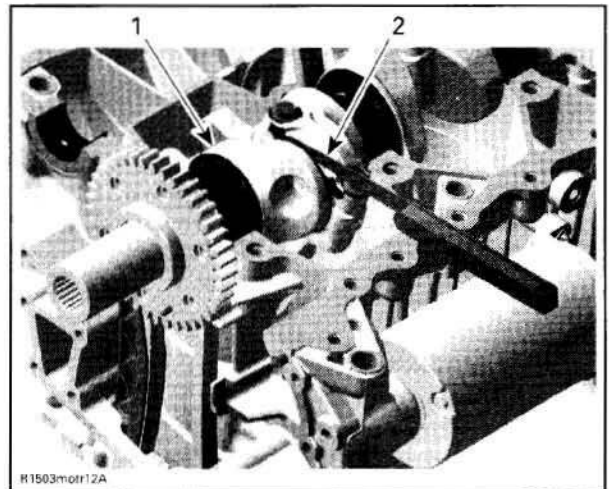

1. Crankshaft
2. Feeler gauge

CONNECTING ROD BIG END AXIAL PLAY mm (in)	
NEW MINIMUM	0.150 (.06)
NEW MAXIMUM	0.302 (.01)
SERVICE LIMIT	0.5 (.02)

Connecting Rod/Piston Pin Clearance

Measure piston pin. Compare to inside diameter of connecting rod no. 5.

Section 03 ENGINE

Subsection 11 (CYLINDER BLOCK)

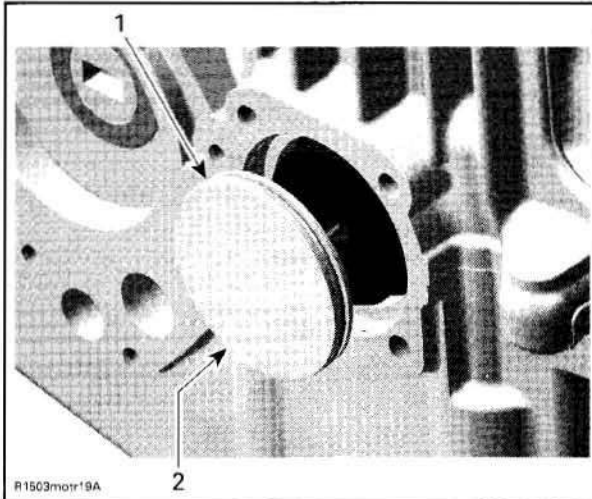

1. O-ring
2. Crankshaft cover

CAUTION: Install crankshaft locking tool (P/N 529 035 821) right away to position crankshaft at TDC before installing the camshaft and rockers (refer to *CYLINDER HEAD*).

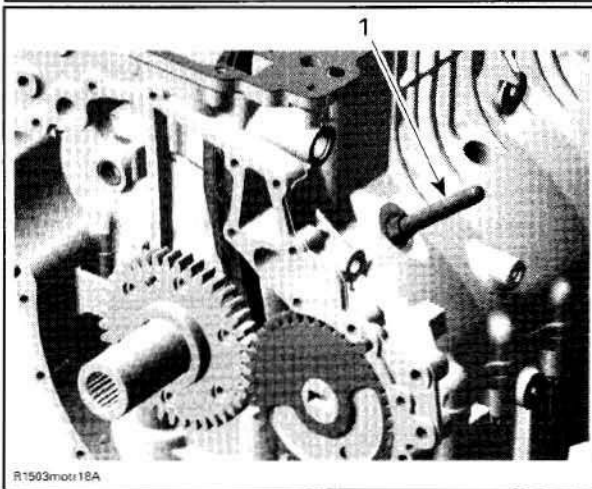
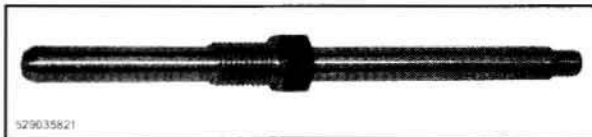

1. Crankshaft locking tool

BALANCER SHAFT

Removal

Remove:

- engine oil (refer to *LUBRICATION SYSTEM*)
- engine from vehicle (refer to *ENGINE REMOVAL AND INSTALLATION*)

- cylinder head (refer to *CYLINDER HEAD* section)
- PTO housing (refer to *PTO HOUSING AND MAGNETO* section)
- starter gear (refer to *PTO HOUSING AND MAGNETO* section)
- starter drive
- oil suction pump (refer to *LUBRICATION SYSTEM* section)
- engine mounting brackets
- oil reservoir plug screws no. 1 with O-ring no. 2

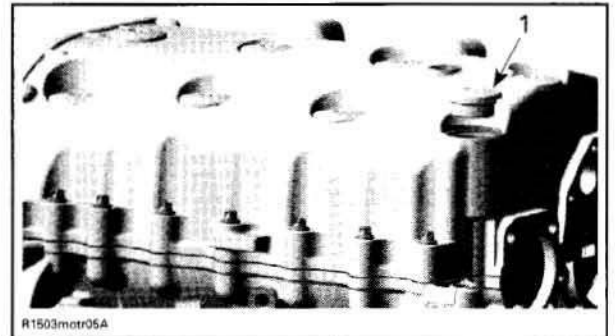

ENGINE UPSIDE DOWN
1. Oil reservoir plug screw with O-ring

- cylinder block screws no. 3

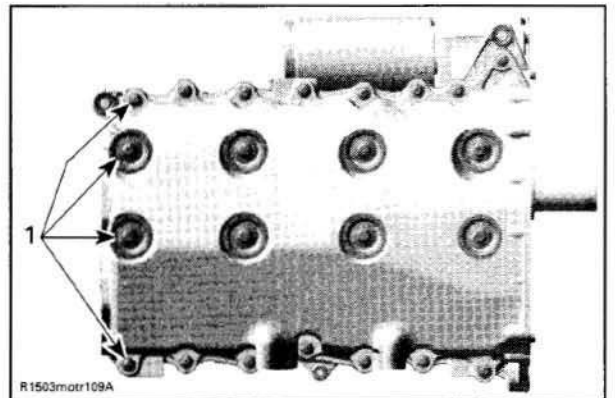

1. Screws

- cylinder block lower half
- thrust washers no. 6

Section 04 ENGINE MANAGEMENT (1503 4-TEC)

Subsection 01 (OVERVIEW)

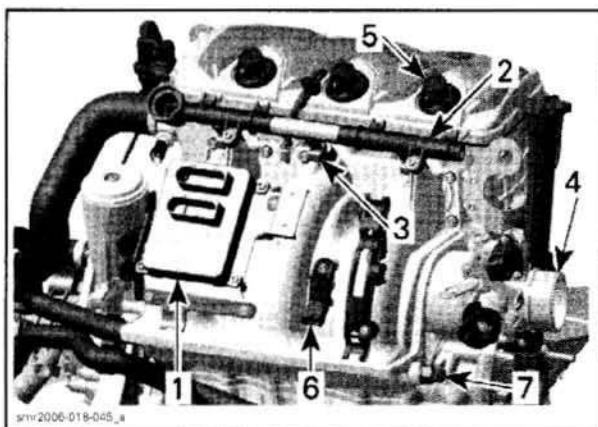

INTAKE MANIFOLD (4-TEC NATURALLY ASPIRATED)

1. Engine Control Module (ECM)
2. Fuel rail
3. Injector
4. Throttle body
5. Ignition coil
6. Manifold air pressure sensor (MAPS)
7. Manifold air temperature sensor (MATS)

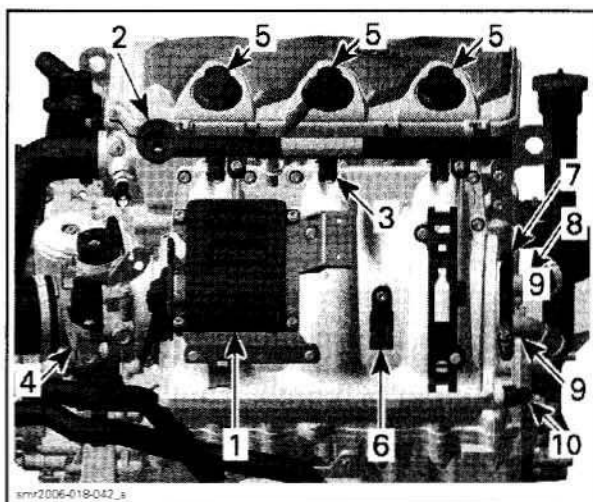

INTAKE MANIFOLD (4-TEC SUPERCHARGED INTERCOOLED)

1. Engine Control Module (ECM)
2. Fuel rail
3. Injector
4. Throttle body
5. Ignition coil
6. Manifold air pressure sensor (MAPS)
7. Intercooler
8. Intercooler outlet
9. Intercooler inlet
10. Manifold air temperature sensor (MATS)

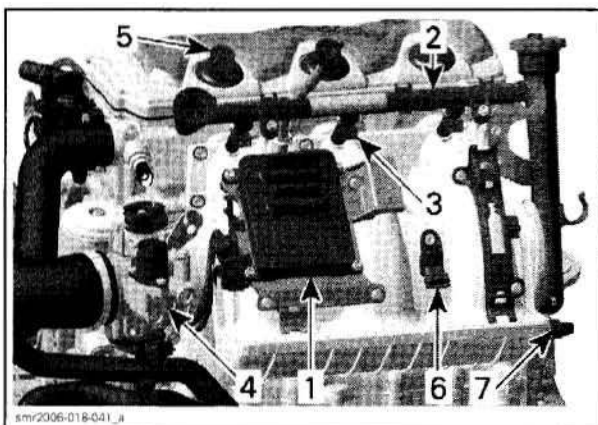

INTAKE MANIFOLD (4-TEC SUPERCHARGED)

1. Engine Control Module (ECM)
2. Fuel rail
3. Injector
4. Throttle body
5. Ignition coil
6. Manifold air pressure sensor (MAPS)
7. Manifold air temperature sensor (MATS)

Flame Arrester

The flame arrester is a tube inside the intake manifold. It prevents flames leaving through the intake system if the engine backfires.

Intercooler

The intercooler is a tube which comprises smaller tubes. Water taken from the outside of the watercraft is pumped through the smaller tubes and cools down the intake air. Therefore the air density is higher and you get more air into the engine.

FUEL SYSTEM

When the intake valve reaches the correct position, the ECM (Engine Control Module) opens the fuel injector and fuel is discharged into the intake port at the intake manifold by the high fuel pressure inside the fuel rail. The air/fuel mixture enters then the combustion chamber through the open intake valve. This mixture is then ignited by the spark plug.

Fuel Rail

The fuel rail is a small tube on which the three injectors are mounted. It ensures all the time, that enough fuel at the right pressure can be delivered to the fuel injectors. The fuel rail is fed by the fuel pump.

Supplemental Information for Some Specific Faults

Communication link fault code 1681: Sometimes the information center does not synchronize fast enough for the MPEM. That brings this fault code. Simply clear the fault and try again.

ECM fault codes P0601, P0602, P0604 and P605: These codes may occur in the following situations:

- Electrical noise is picked up by the ECM. Ensure that all connections are in good condition, also grounds (battery, ECM, engine and ignition system), they are clean and well tightened and that all electronic components are genuine – particularly in the ignition system. Installing resistive caps, non-resistive spark plugs or improper knock sensor wiring/routing may lead to generate this fault code.
- Electrical noise might also lead engine to occasional cutout without generating a fault code when engine is restarted. When looking at the fault code, pay attention to the "count" value in the software B.U.D.S. A value between 1 and 9 confirms an electrical noise problem. A value of 10 and above will generate a fault code.
- When installing a new ECM. It is not properly programmed from the factory. The ECM must be returned to be properly "activated".
- If everything is in good condition, try a new ECM.

Fault code P1513: Wrong ECM or information center. Installed part is not appropriate for the vehicle. Engine will crank but will not start. Refer to parts catalogs for proper part according to vehicle.

CLICK HERE TO **DOWNLOAD** THE COMPLETE MANUAL

- Thank you very much for reading the preview of the manual.
- You can download the complete manual from: www.heydownloads.com by clicking the link below



- Please note: If there is no response to **CLICKING** the link, please download this PDF first and then click on it.

CLICK HERE TO **DOWNLOAD** THE COMPLETE MANUAL

Section 04 ENGINE MANAGEMENT (1503 4-TEC)

Subsection 03 (ADJUSTMENT AND REPAIR PROCEDURES)

NOTE: For more details on ECM connectors servicing, refer to *ELECTRICAL CONNECTORS AND WIRING DIAGRAM* section.

Engine Wiring Harness

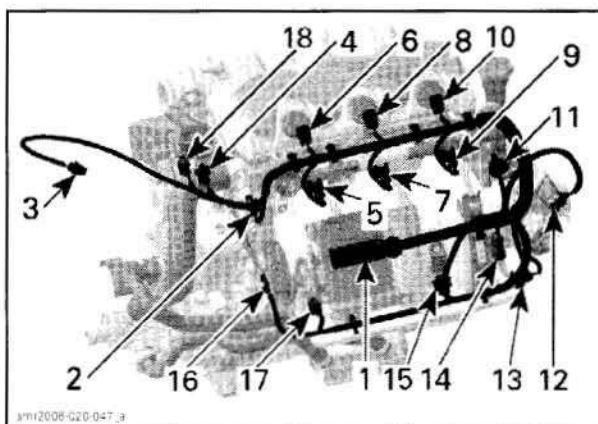

4-TEC NATURALLY ASPIRATED ENGINES

1. ECM connector
2. CTS connector
3. EGTS connector
4. CAPS connector
5. Fuel injector connector (cylinder 1)
6. Ignition coil connector (cylinder 1)
7. Fuel injector connector (cylinder 2)
8. Ignition coil connector (cylinder 2)
9. Fuel injector connector (cylinder 3)
10. Ignition coil connector (cylinder 3)
11. TPS connector
12. Idle bypass valve connector
13. MATS connector
14. Engine connector
15. MAPS connector
16. OPS connector
17. KS connector
18. CPS connector

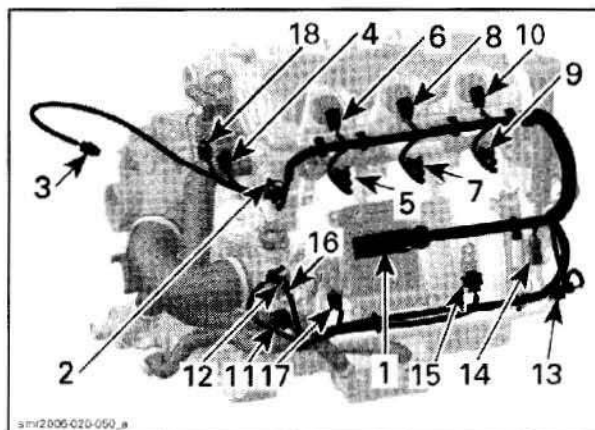

ALL 4-TEC SUPERCHARGED ENGINES

1. ECM connector
2. CTS connector
3. EGTS connector
4. CAPS connector
5. Fuel injector connector (cylinder 1)
6. Ignition coil connector (cylinder 1)
7. Fuel injector connector (cylinder 2)
8. Ignition coil connector (cylinder 2)
9. Fuel injector connector (cylinder 3)
10. Ignition coil connector (cylinder 3)
11. TPS connector
12. Idle bypass valve connector
13. MATS connector
14. Engine connector
15. MAPS connector
16. OPS connector
17. KS connector
18. CPS connector

Resistance Test

Check continuity of the circuits according to the wiring diagram in the *ELECTRICAL CONNECTORS AND WIRING DIAGRAM* section of this manual.

If wiring harness is good, check the respective sensor/actuator as described in this section.

Otherwise, repair the connectors, replace the wiring harness or the ECM/MPEM as diagnosed.

Removal

Remove fuel rail cover.

Disconnect the wiring harness from all sensors/actuators.

Disconnect the ECM connector from the ECM.

Cut all tie raps which are holding the wiring harness in position.

Section 04 ENGINE MANAGEMENT (1503 4-TEC)

Subsection 03 (ADJUSTMENT AND REPAIR PROCEDURES)

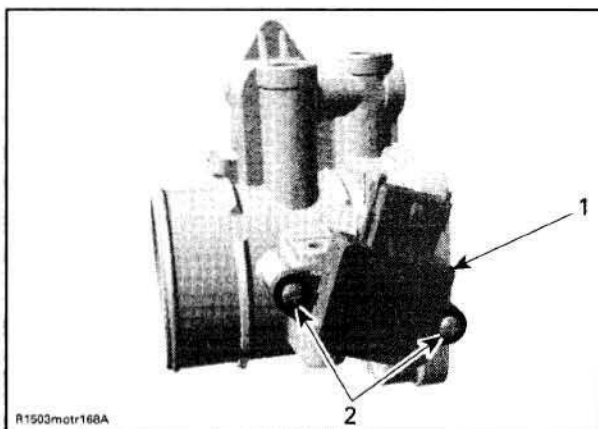

THROTTLE BODY

1. Throttle position sensor (TPS)
2. Screws

Apply Loctite 243 on screw threads, install the new TPS.

Reinstall remaining removed parts.

Proceed with the **Closed Throttle and Idle Actuator** reset as described in *BASIC ADJUSTMENTS*.

IDLE BYPASS VALVE

An idle bypass valve with good resistance measurement can still be faulty. It is also possible that a mechanical failure occurs which is not detectable without measuring the air flow. Replacing the idle bypass valve may be necessary as a test.

Resistance Test

Disconnect idle bypass valve from the wiring harness.

Using a multimeter, check the resistance in both windings.

Check the resistance between terminals A and D and also between terminals C and B of the idle bypass valve.

The resistance in each winding should be approximately 50 Ω at 23°C (73°F).

If the resistance of one or both windings is not good, replace the idle bypass valve.

If resistance test of valve windings is good, check continuity of circuits A-35, A-36, A-37, A-38.

Visual Inspection

Remove idle bypass valve from throttle body.

Check the piston and bypass channel for dirt/deposits which can cause a sticking piston.

CAUTION: Do not try to operate the piston of the idle bypass valve when it is dismantled. Also do not move the piston by hand. The screw drive is very sensitive and will be destroyed.

Clean the parts and install the idle bypass valve on the throttle body.

Proceed with the **Closed Throttle and Idle Actuator** reset as described in *BASIC ADJUSTMENTS*.

CRANKSHAFT POSITION SENSOR (CPS)

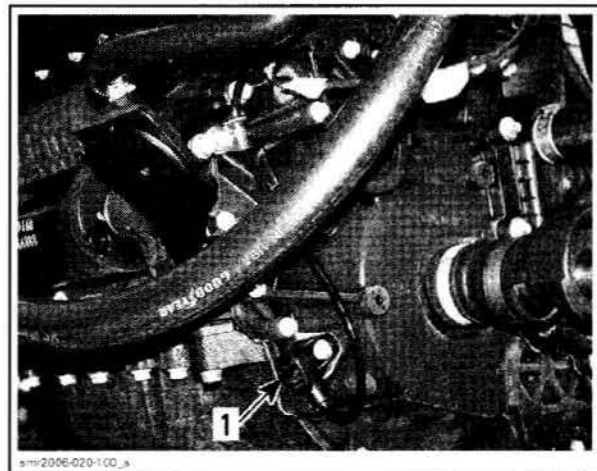

1. Crankshaft Position Sensor (CPS)

Ensure that information center works. Needles will sweep, LED and LCD segments will turn on when the safety lanyard is installed. Check for RPM display at the information center while cranking in engine drowned mode. Press and HOLD throttle lever then press start/stop button. 800 - 1000 RPM should display. Otherwise perform the following tests.

NOTE: Take into account that a CPS fault can be triggered by a bent or missing trigger wheel tooth. First check fault codes then CPS as per following procedure; if it tests good, verify trigger wheel teeth condition. Refer to *PTO HOUSING AND MAGNETO* in the *ENGINE* section.

Disconnect CPS wiring harness connector. Probe terminals coming from CPS while cranking engine. Voltage should be within 1 - 2 Vac. Otherwise, inspect wiring and replace CPS if wiring is good.

Resistance Test

Disconnect the CPS connector from the wiring harness and check the resistance of the sensor itself.

Section 05 FUEL SYSTEM

Subsection 01 (FUEL TANK AND FUEL PUMP)

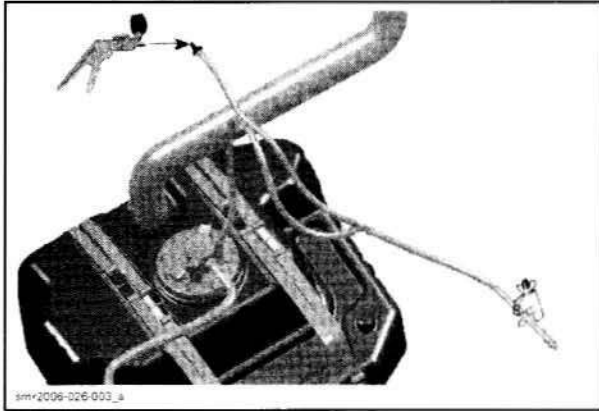

PRESSURE	TIME WITHOUT PRESSURE DROP
34 kPa (5 PSI)	10 minutes

If pressure drops, locate fuel leak(s) and repair/replace leaking component(s).

To ease locating leak(s), spray soapy water on components; bubbles will indicate leak location(s).

⚠ WARNING

If any leak is found, do not start the engine and wipe off any fuel leakage. Do not use electric powered tools on watercraft unless system has passed pressure test.

Check Valve and Pressure Relief Valve

Air can enter fuel tank at all times through INLET side.

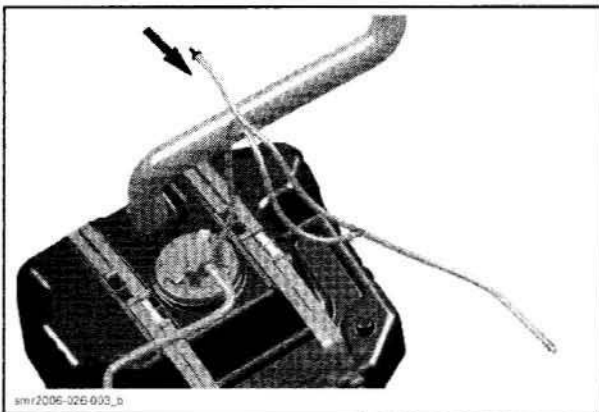

The check valve no. 18 prevents fuel to flow out. Air cannot go out (unless pressure increases).

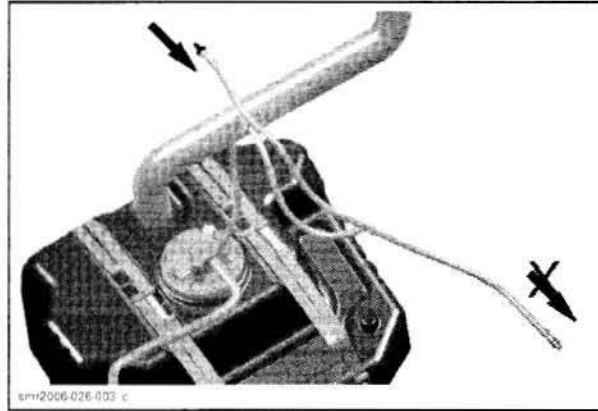

⚠ WARNING

If pressure relief valve is stuck, the pressure in fuel system will build up and it may cause fuel leakage in engine compartment.

Always reinstall valve with the black side as shown.

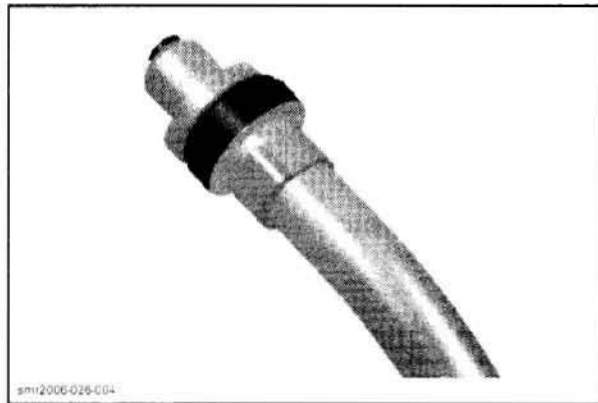

If pressure in fuel tank build up and exceed 3.5 kPa (.5 PSI), pressure relief valve no. 17 open and let excess pressure evacuate through OUTLET side.

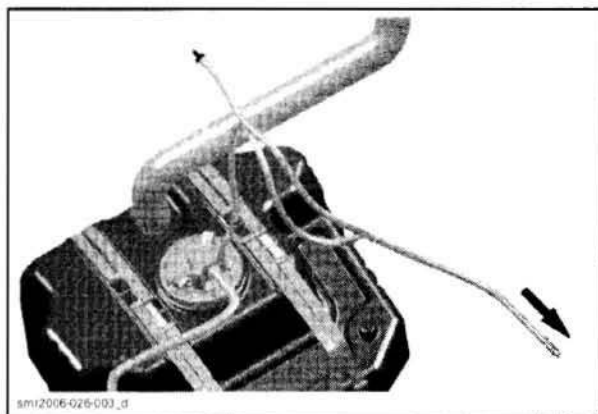

Always reinstall valve according to arrow on valve as shown.

GENERAL

NOTE: It is a good practice to check for fault codes using B.U.D.S. software as a first troubleshooting step. Refer to *EMS DIAGNOSTIC AND COMMUNICATION TOOLS*.

NOTE: The EMS controls the ignition system. For more information, refer to *ENGINE MANAGEMENT*.

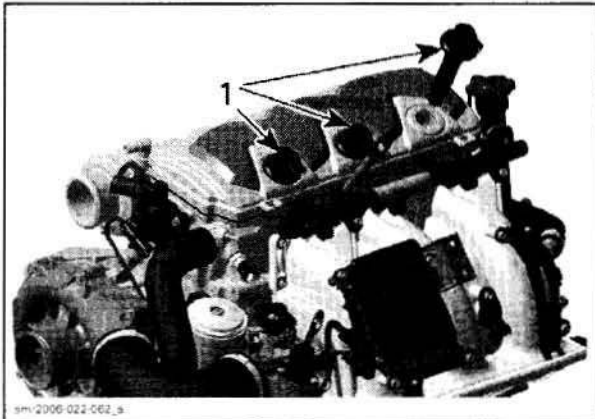

1. Ignition coil

NOTE: The MPem energizes the primary side of each ignition coil individually while the ECM completes the circuit by switching it to the ground at the right moment. The ECM can detect open and short circuit in the primary winding but it does not check the secondary winding.

⚠ WARNING

Never check for engine ignition spark from an open coil and/or spark plug in the engine compartment as spark may cause potential fuel vapor to ignite.

CAUTION: Do not remove the ignition coil before disconnecting the connector, or the wires will be damaged. Do not pry up ignition coil with a screwdriver to avoid damage.

PROCEDURES

IGNITION COIL

Quick Test with B.U.D.S.

Using the B.U.D.S. software, energize the ignition coil.

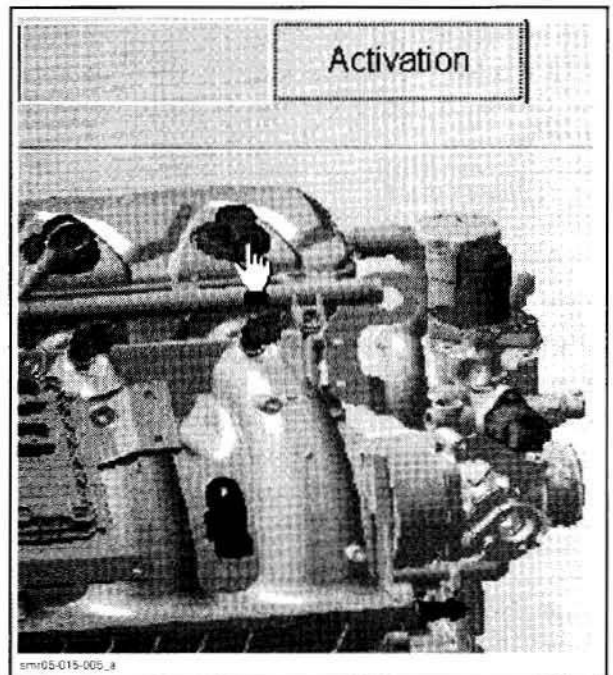

You should hear the spark occurring. In doubt, use an inductive spark tester or a sealed tester - available from tool suppliers to prevent spark occurring in the bilge. If there is no spark, perform the following checks.

NOTE: Keep in mind that even if there is a spark during this static test, voltage requirement is higher to produce a spark in the combustion chamber when engine is running. Ignition coil could be not working in real operation. Replacing ignition coil may be necessary as a test.

Voltage Test

Disconnect the connector from the ignition coil and check the voltage supplied by the MPem.

Install safety lanyard on the DESS post. Read voltage.

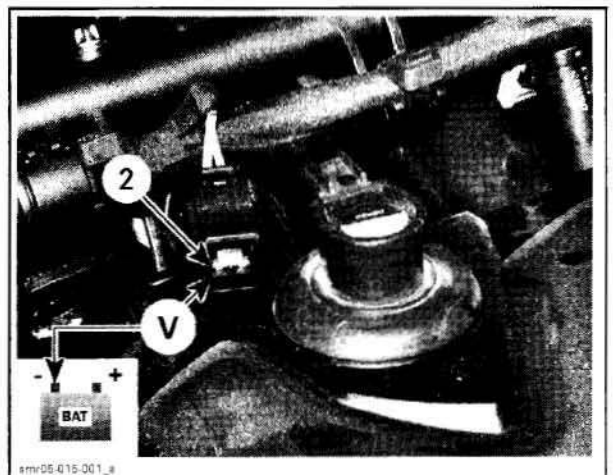

Section 06 ELECTRICAL SYSTEM
Subsection 02 (CHARGING SYSTEM)

Check valve must hold air with 34 kPa (5 PSI) without leaking when orange side is on pump side.

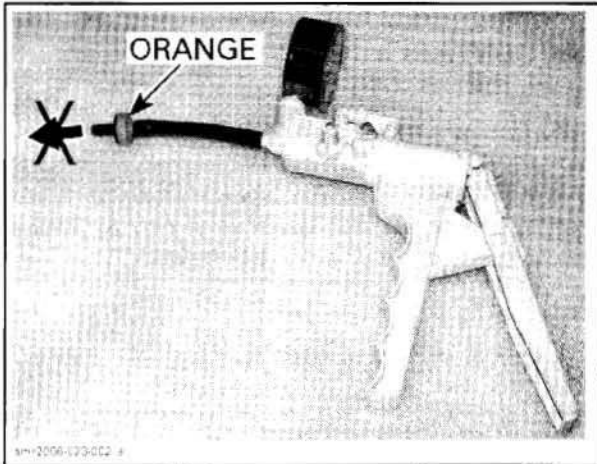

MUST HOLD AIR IN THIS POSITION

At installation, ensure to position check valve with the orange side as shown.

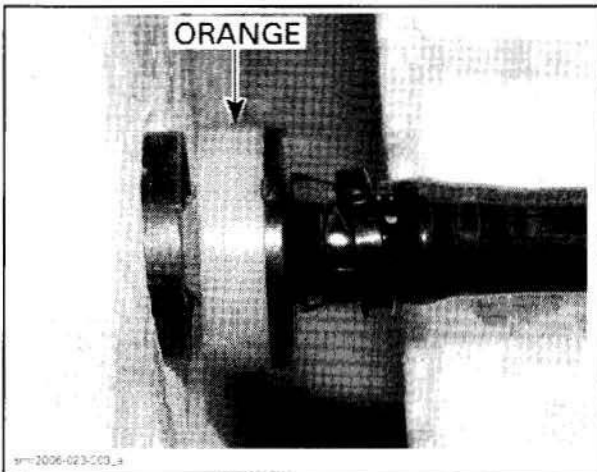

Battery Testing

There are 2 types of battery tests: electrolyte reading and load test. An electrolyte reading is made on a battery without discharging current. It is the simplest and commonly used. A load test gives more accuracy of the battery condition.

Electrolyte Reading

Check charge condition using either a hydrometer or multimeter.

Set multimeter to Vdc and measure voltage at battery posts.

BATTERY CONDITION	VOLTAGE
Fully charged	12.6 Vdc

A hydrometer measures the charge of a battery in terms of specific gravity of the electrolyte.

BATTERY CONDITION	SPECIFIC GRAVITY
Fully charged	1.265 - 1.280

Most hydrometers give a true reading at 21°C (70°F).

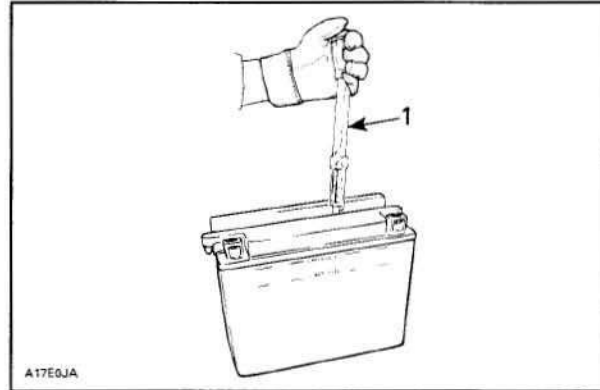

1. Specific gravity 1.265

In order to obtain correct readings, adjust the initial reading by adding .004 points to the hydrometer readings for each 5.5°C (10°F) above 21°C (70°F) and by subtracting .004 point for every 5.5°C (10°F) below 21°C (70°F).

This chart will be useful to find the correct reading.

ELECTROLYTE TEMPERATURE		OPERATION TO PERFORM	
°C	°F		
38	100	.012	Add to the reading
32	90	.008	
27	80	.004	
21	70	CORRECT READING	
16	60	.004	Subtract from the reading
10	50	.008	
4	40	.012	
- 1	30	.016	

EXAMPLE NO. 1

TEMPERATURE ABOVE 21°C (70°F):
 Hydrometer reading: 1.250
 Electrolyte temperature: - 1°C (30°F)
 Subtract .016 Sp. Gr.
 Corrected Sp. Gr. is 1.234

EXAMPLE NO. 2

TEMPERATURE ABOVE 21°C (70°F):
 Hydrometer reading: 1.235
 Electrolyte temperature: 38°C (100°F)
 Add .012 Sp. Gr.
 Corrected Sp. Gr. is 1.247

Section 06 ELECTRICAL SYSTEM
Subsection 03 (STARTING SYSTEM)

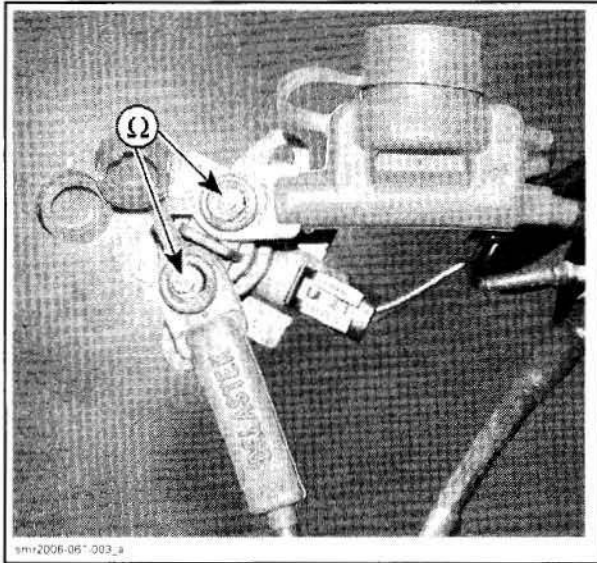

SOLENOID POST		VOLTAGE (DC)
Post coming from battery	Post going to starter	0.2 V max.

If voltage is out of specification, replace solenoid.

⚠ WARNING
 Remove rubber band from throttle lever to release it.

PARTS REPLACEMENT

STARTER

Removal

Disconnect BLACK cable ground connection from battery.

⚠ WARNING
 Always disconnect ground cable first and re-connect last.

Disconnect RED cable connection from battery.

NOTE: To facilitate starter removal on RXP models, remove engine cover. Refer to BODY section.

Remove retaining screws from starter.

Pull starter out. Lift starter enough to reach starter cable then disconnect from starter.

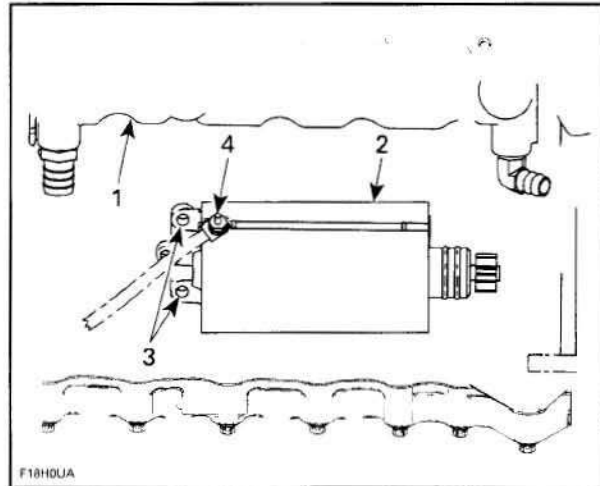

- 1. Exhaust manifold
- 2. Starter
- 3. Retaining screws
- 4. Nut

Installation

Installation is essentially the reverse of removal procedure. However, pay particular attention to the following.

Make sure that starter and engine mating surfaces are free of debris. Serious trouble may arise if starter is not properly aligned.

Apply grease Isoflex grease Topas NB52 (P/N 293 550 021) on O-rings of starter.

Install starter.

NOTE: If starter does not mesh properly, try to pull it out and slightly rotate the starter gear; then re-install starter. One could also temporarily remove both O-rings, properly mesh gears then remove starter to reinstall O-rings, being careful not to rotate gear to keep its position, to finally reinstall starter.

Apply Loctite 243 (P/N 290 897 651) on retaining screws and torque to 10 N•m (89 lbf•in).

Connect the RED positive cable to the starter and torque nut to 7 N•m (62 lbf•in). Apply dielectric grease (P/N 293 550 004) on terminal and nut.

Ensure to slide protector over nut to hide metallic parts.

Section 06 ELECTRICAL SYSTEM

Subsection 05 (GAUGE, SENSORS AND FUSES)

Water Depth

Display the water depth under the hull within 0 to 50 meters (0 to 170 feet).

NOTE: Under certain conditions, the gauge may stop displaying. The gauge ability to display the depth depends on the usage conditions.

WARNING

Never use the depth gauge as a warning device to ride in shallow water. Use it as a navigation guide only. Not to be used for navigation purposes.

NOTE: Water temperature and depth gauge will be displayed alternately.

All Models

Hourmeter (HR)

Displays the time in hours of the watercraft usage.

Message Display

Displays a message whenever one of the following circumstances occurs. The abbreviations between parenthesis here are the code displayed:

- engine or exhaust system overheating (EX-HAUST or ENGINE)
- low oil pressure (OIL)
- low battery voltage (12 V LOW)
- high battery voltage (12 V HI)
- low fuel level (FUEL-LO)
- maintenance reminder (MAINT)

NOTE: When the watercraft is due for a maintenance inspection, the message MAINT will blink. After servicing, clear it using B.U.D.S.

- check engine (CHK ENG)

NOTE: If a fault occurs, this system generates numbered fault codes (P-XXXX) that are displayed through the information center. Use B.U.D.S. to help troubleshooting.

- sensor failure (vehicle electronic equipment) (SENSOR)
- invalid safety lanyard (KEY)
- safety lanyard, learning key active (L KEY) (includes the Rental key as well).

A beeper will sound and indicator light will blink depending on the fault occurring to catch the driver attention when necessary. Use B.U.D.S. for troubleshooting when such a message is displayed.

5) Indicator Lights

NOTE: Refer to *INFORMATION DISPLAY* above for additional information regarding messages.

Low oil pressure (OIL)



Check engine (CHK ENG)



Engine or exhaust system overheating (H-TEMP)



Low fuel level (FUEL-LOW)



Low/high battery voltage (12 V LOW/HI)



Maintenance reminder (MAINT)



6) Water Depth Display

On so Equipped Models

Displays the water depth under the hull within 0 to 50 meters (0 to 170 feet).

NOTE: Under certain conditions, the gauge may stop displaying. The gauge ability to display the depth depends on the usage conditions.

WARNING

Never use the depth gauge as a warning device to ride in shallow water. Use it as a navigation guide only. Not to be used for navigation purposes.

Section 07 PROPULSION

Subsection 01 (JET PUMP)

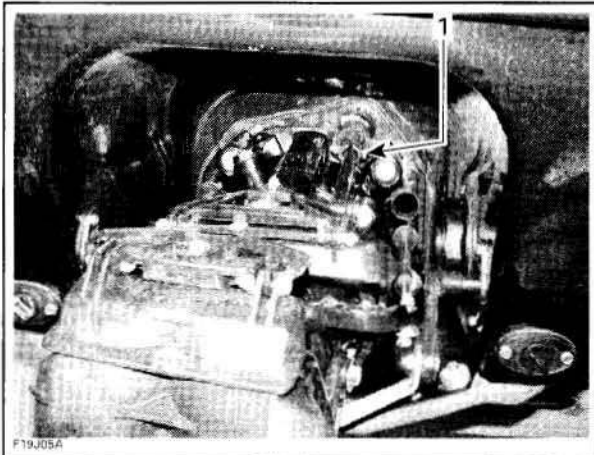

1. Link rod

All Models

Disconnect steering and reverse cables.

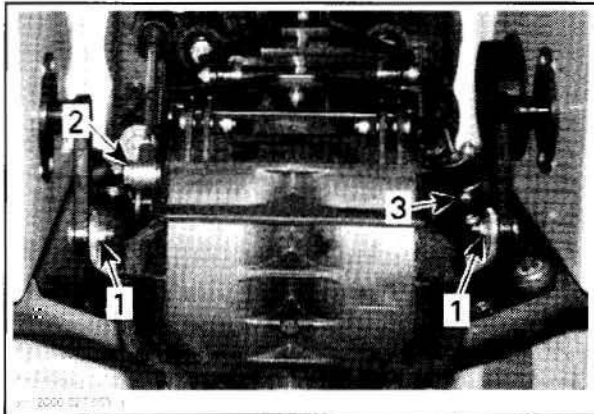

1. O.P.A.S. "U" lever screws
2. Reverse cable
3. Steering cable

Remove O.P.A.S. "U" lever screws.

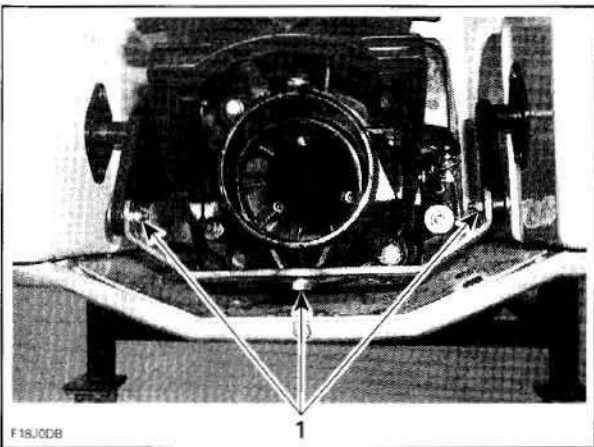

TYPICAL
1. "U" lever screws

Remove bolts securing venturi to jet pump housing.

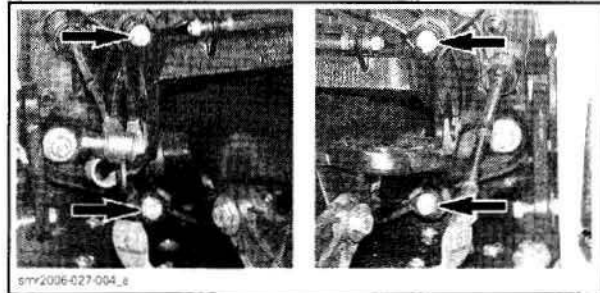

Installation

The installation is the reverse of the removal procedure. Pay attention to the following.

If needed, install new O-rings around bailer passages.

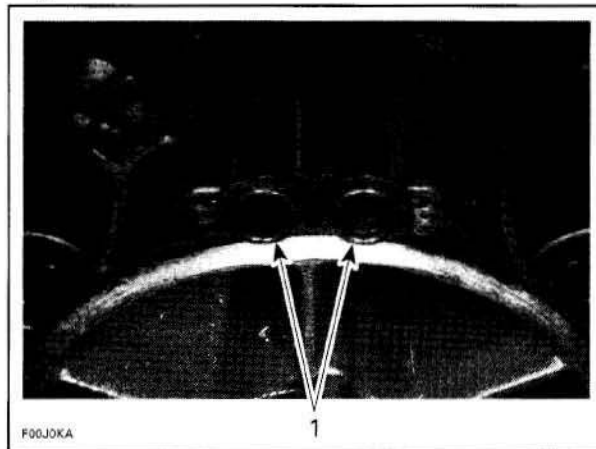

1. O-rings

Position venturi with bailer passages on top.

Apply Loctite 243 (blue) (P/N 293 800 060) on threads of venturi bolts.

Install venturi bolts and flat washers then torque to 21 N•m (16 lbf•ft).

JET PUMP HOUSING

NOTE: The jet pump housing can be removed as an assembly with the reverse gate, nozzle and venturi. This is the preferred procedure when either the drive shaft or engine removal is required.

Removal

Remove venturi, see procedure above.

NOTE: To remove jet pump as an assembly, follow venturi removal procedure but do not unscrew venturi from jet pump housing.

Section 07 PROPULSION
Subsection 01 (JET PUMP)

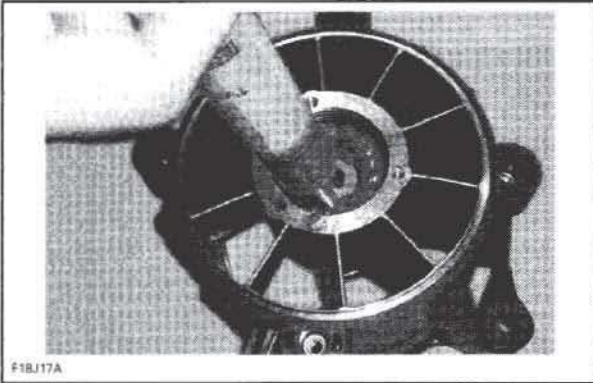

TYPICAL

NOTE: The remaining grease in the tube will be used for the impeller cover.

Section 07 PROPULSION

Subsection 02 (DRIVE SYSTEM)

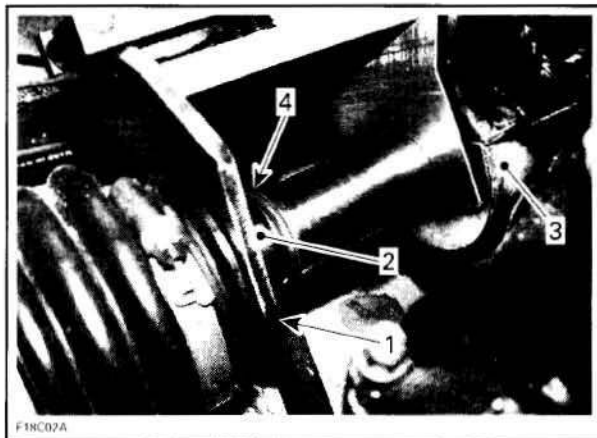

TYPICAL

1. Largest opening
2. Floating ring
3. PTO seal support tool
4. Install circlip

Remove drive shaft/floating ring tool, drive shaft holder then PTO seal support.

NOTE: Pushing boot rearwards will ease removal of PTO seal support tool.

Now ensure everything is properly positioned:

- telltale groove is not visible
- inner sleeve is flush with outer circumference of PTO seal assembly
- circlip is not exposed.

If telltale groove is visible, push PTO seal assembly rearwards to fully extend it.

If inner sleeve is not flush, gently tap it until it is flush.

Reposition rubber protector.

Reconnect EGTS sensor.

Install jet pump. Refer to *JET PUMP*.

Check engine oil level. Refill as necessary.

Run watercraft then ensure there is no oil leak in PTO seal area.

BOOT

Inspection

Inspect the condition of boot. If there is any damage or evidence of wear, replace it.

Removal

Remove drive shaft. Refer to *DRIVE SHAFT* in this section.

Loosen gear clamp holding boot, then carefully pull boot and carbon ring from hull insert.

Installation

The installation is the reverse of the removal procedure.

CARBON RING

Removal

Remove drive shaft. Refer to *DRIVE SHAFT* in this section.

Loosen gear clamp then pull carbon ring from boot.

Installation

The installation is the reverse of the removal procedure.

Section 07 PROPULSION

Subsection 04 (VARIABLE TRIM SYSTEM)

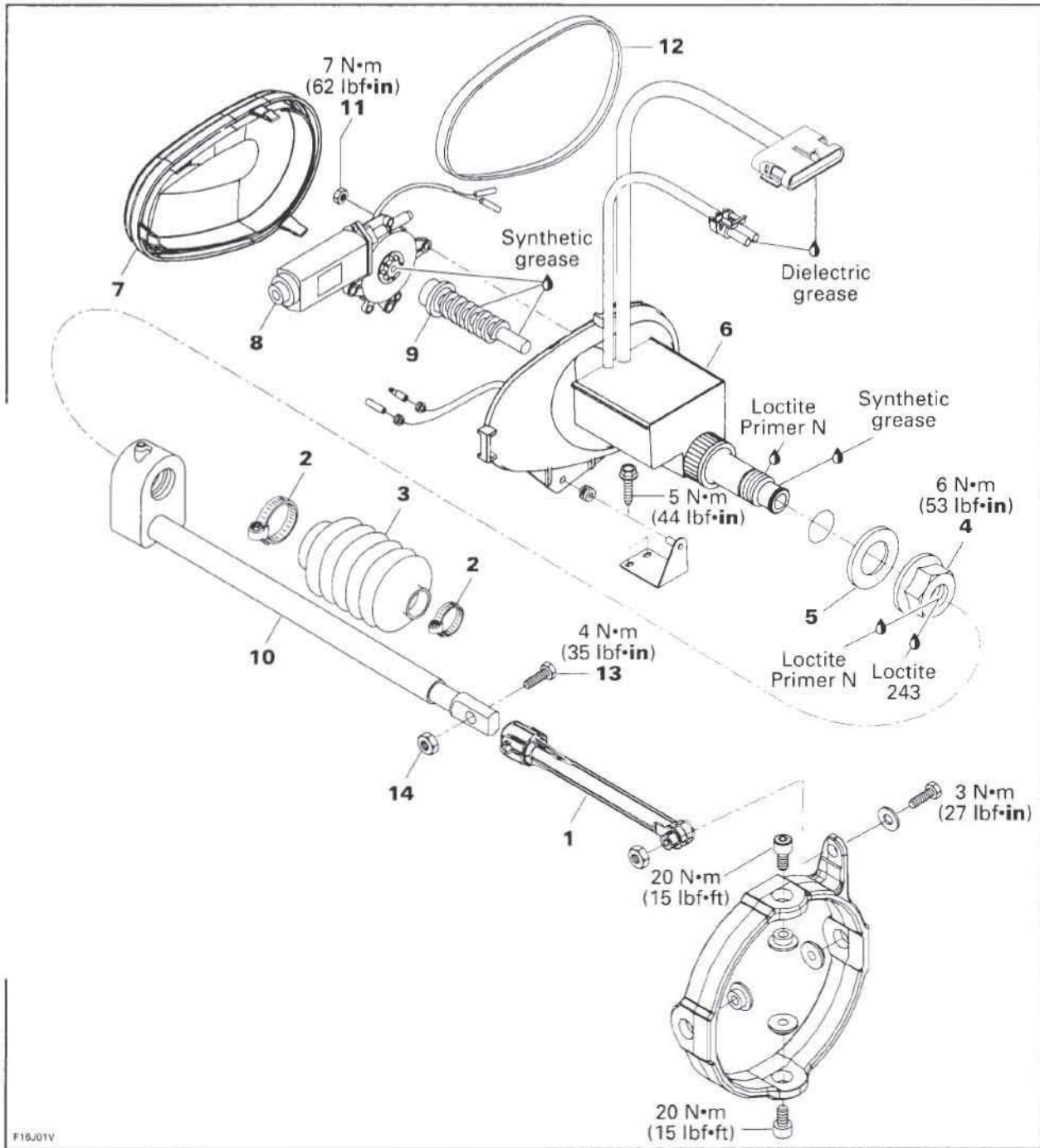

F16J01V

Section 08 STEERING SYSTEM
Subsection 01 (STEERING SYSTEM)

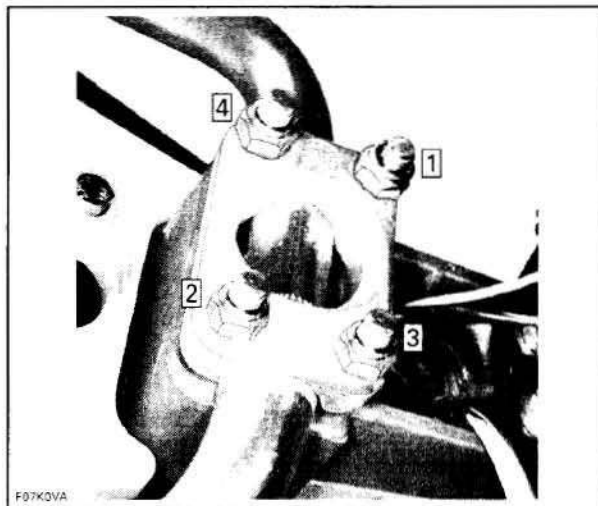

STEERING CABLE SUPPORT

Removal

RXP Models

Open front storage cover and remove basket.
 Remove front vent tube.

GTI Series

Remove glove box and console. Refer to *BODY AND HULL*.

GTX Series and RXT Models

Open front storage cover and remove rear access panel.

All Models

Unscrew bolts securing retaining block then remove it from steering cable support.

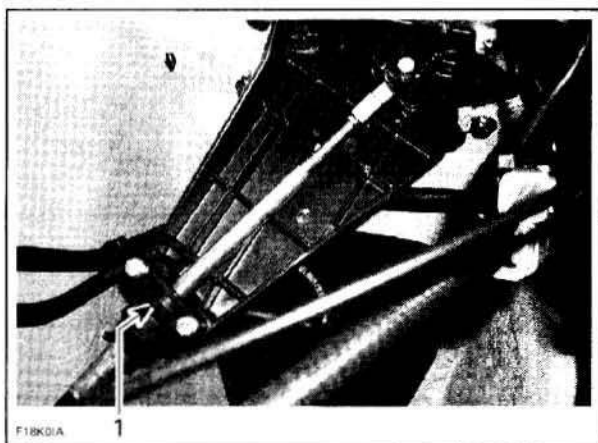

1. Retaining block

Loosen bolts each side of steering support.

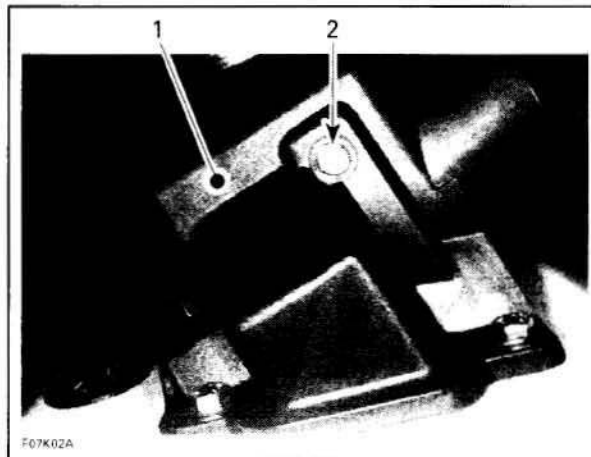

RIGHT SIDE
 1. Steering support
 2. Bolt

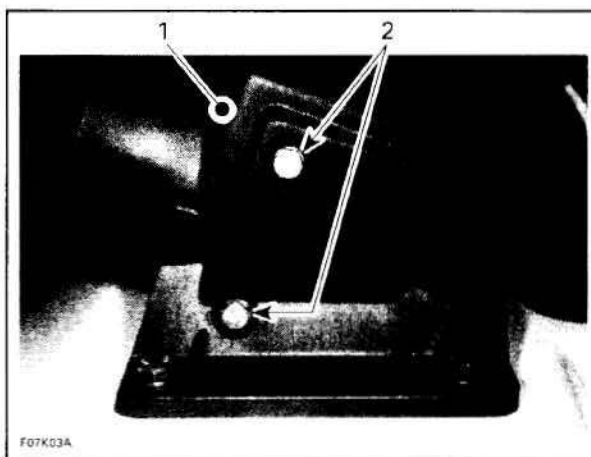

LEFT SIDE
 1. Steering support
 2. Bolts

Detach fuel lines from steering cable support.

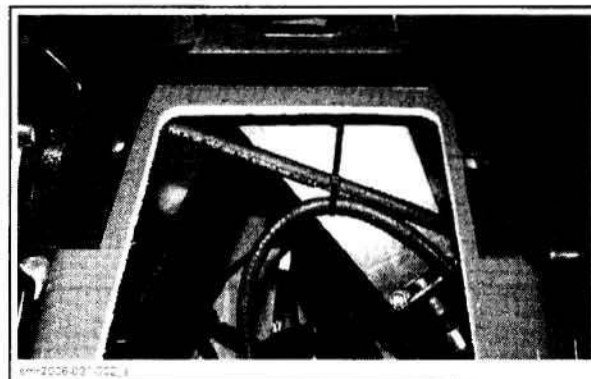

GTI SE MODEL SHOWN

Remove steering cable support.

Section 08 STEERING SYSTEM

Subsection 02 (OFF-POWER ASSISTED STEERING (O.P.A.S.))

- Install the valve.
- Torque Phillips screws no. 33 to 2.2 N•m (19 lbf•in).
- Install water hoses no. 10 on valve.
- Tighten gear clamps no. 30 manually to 1.7 N•m (15 lbf•in).

WATER HOSE

GTX and RXT Series

Removal

Removal procedure for RH and LH water hose no. 10 is same.

Remove side vane no. 1 and cylinder support no. 6 as mentioned above.

Remove gear clamps no. 30 to remove water hose no. 10 from valve no. 31.

Pull out the water hose from exterior.

Installation

Installation is the reverse process of removal, make sure of the following when doing installation:

- Water hose must be installed from the outside to the inside of hull by turning it, oriented towards valve.
- Tighten gear clamps no. 30 manually to 1.7 N•m (15 lbf•in).

SIDE VANE

Removal

Removal procedure for RH and LH side vane no. 1 is same.

Remove socket screw no. 2.



1. Socket screw

Remove the tie-rod screw no. 3.

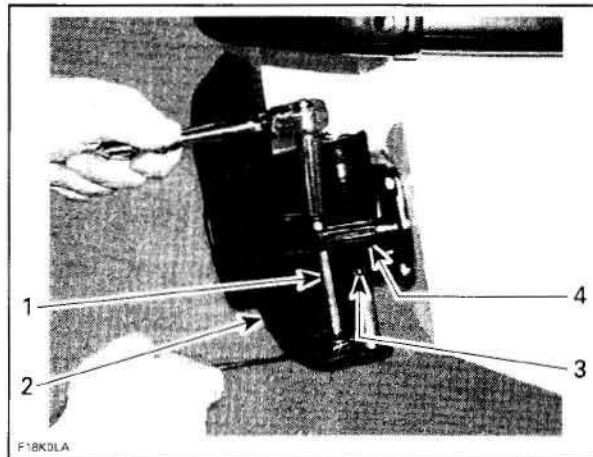

1. Tie rod screw
2. Side vane
3. Cylinder support
4. Tie rod fitting

Lift pivot shaft no. 4 while holding top of side vane. Pull side vane out.

Adjustment

During tie-rod fitting adjustment, tie-rod screw no. 3 must be loose and socket screw no. 2 removed.

Put the steering in straight ahead position.

Measure the portion of tie rod fitting no. 5 exceeding from cylinder support no. 6.

The exceeding distance of tie rod fitting from the cylinder support should be 45 ± 1 mm ($1.65 \pm .04$ in).

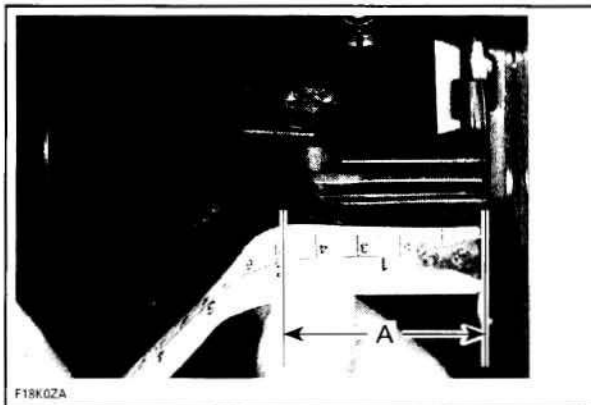

A. 45 ± 1 mm ($1.65 \pm .04$ in)

To adjust the tie-rod fitting no. 5, remove tie-rod screw no. 3 and turn tie-rod fitting. Place tie-rod screw in its place and measure again. Repeat the procedure until the distance is reached.

When the adjustment is done, torque the tie-rod screw to 4.5 N•m (40 lbf•in).

Section 09 HULL/BODY
Subsection 01 (ADJUSTMENT AND REPAIR)

GTI Models (hull)

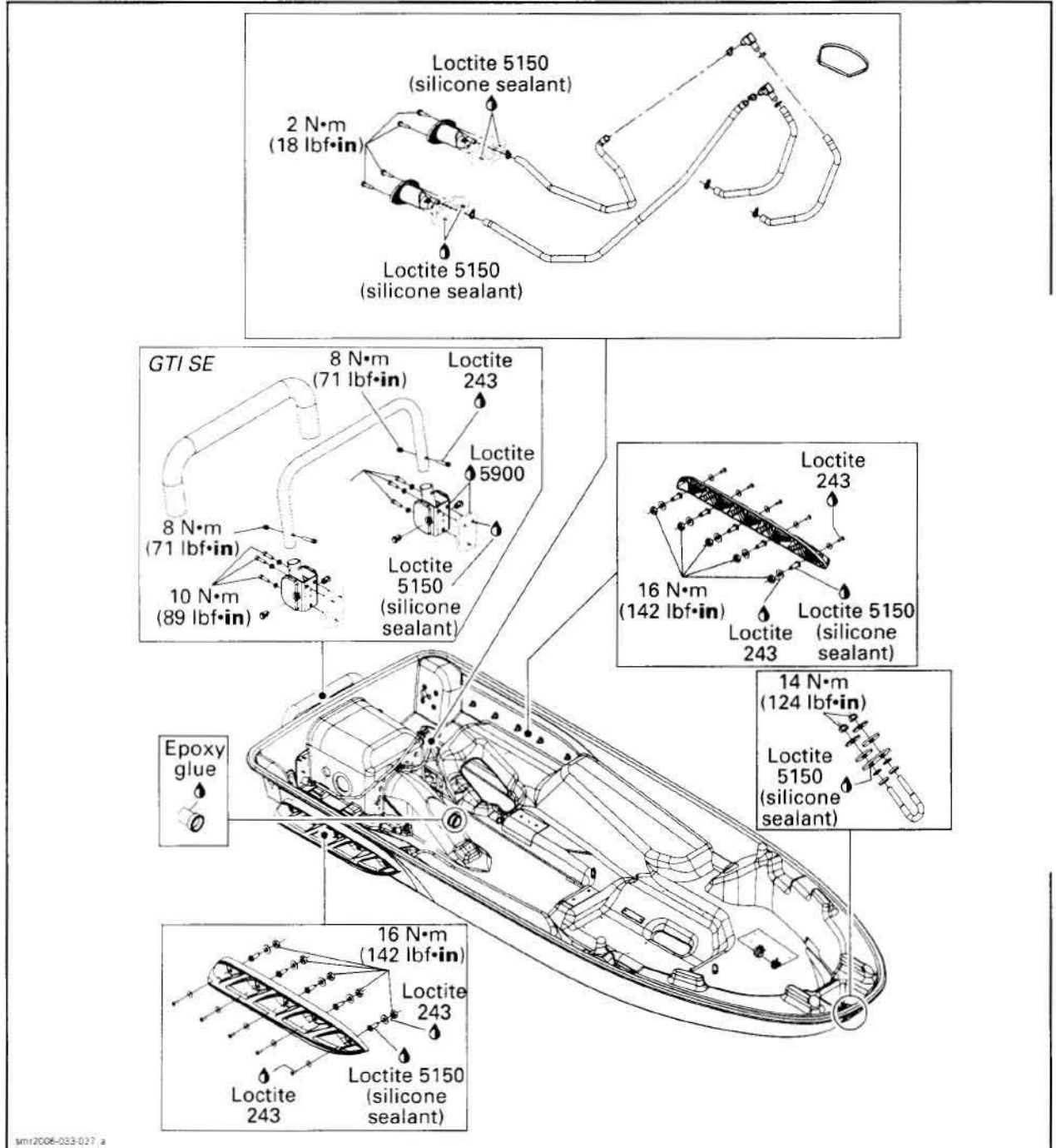

Section 09 HULL/BODY

Subsection 01 (ADJUSTMENT AND REPAIR)

RXP Models (hull)

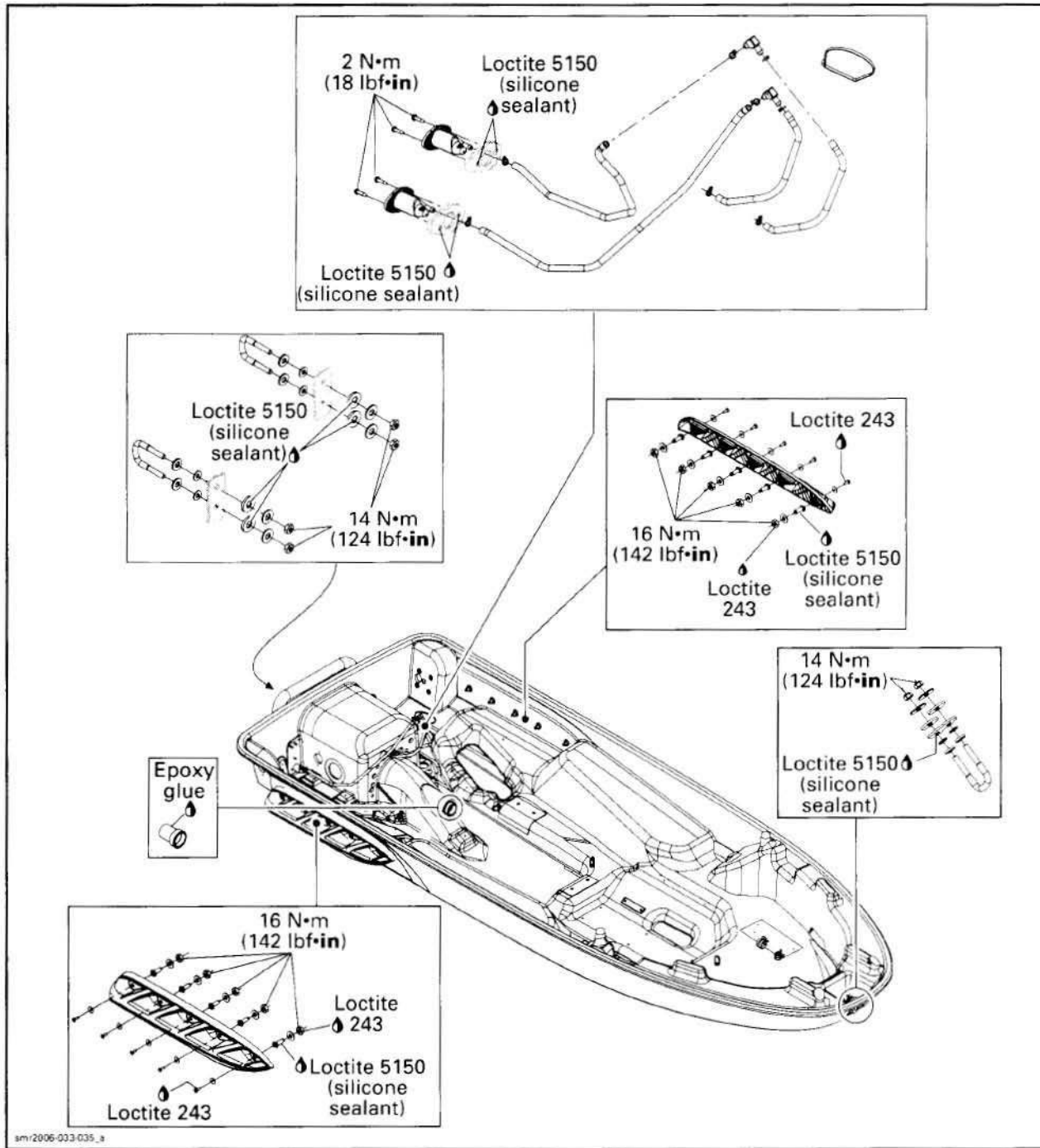

Remove storage compartment cover.

Installation

The installation is the reverse of the removal procedure.

GTI Series

When installing screws retaining storage compartment cover, use **NEW screw with Scotch Grip**. NEVER use liquid threadlocker with this cover.

STORAGE COMPARTMENT COVER HINGE

Removal

GTI Series

Remove storage compartment cover, see above.

Unscrew the 5 bolts securing the hinge to the body.

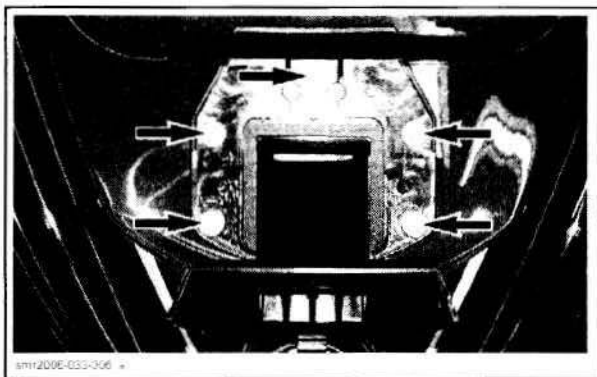

Pull hinge to remove it from body.
Cut a push nut retaining hinge shaft.

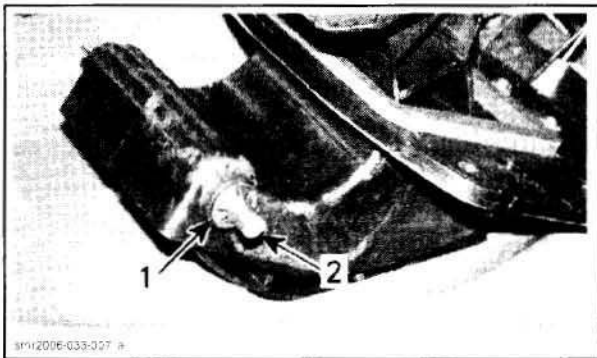

- 1. Push nut
- 2. Hinge shaft

Remove hinge shaft and separate both parts of hinge.

Installation

For installation, reverse the removal procedure.

STORAGE COMPARTMENT COVER SHOCK

Removal

All Models except GTI Series

Unlock shock rod from circlip and remove washer.

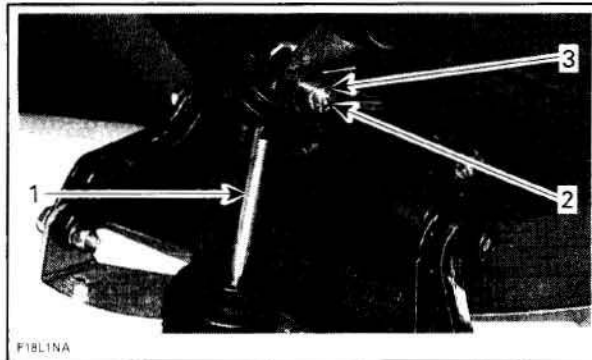

- 1. Shock rod
- 2. Circlip
- 3. Washer

Install a 2 x 4 piece of wood between storage cover and body. This piece of wood will support the storage cover while changing the cover shock.

Release the shock from top linkage bracket and bottom support bracket by inserting a flat screwdriver in the shock top and bottom locking devices.

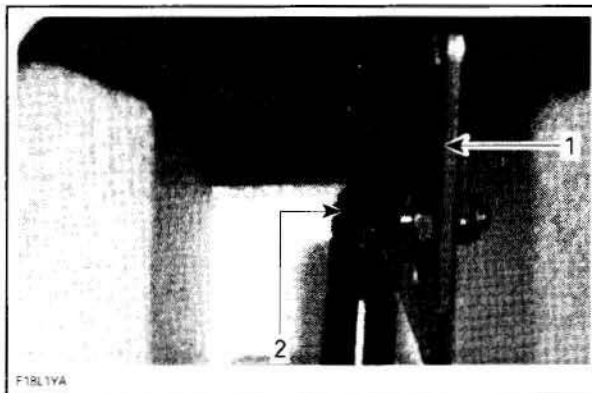

- 1. Top linkage bracket
- 2. Shock top locking device

Section 09 HULL/BODY
Subsection 01 (ADJUSTMENT AND REPAIR)

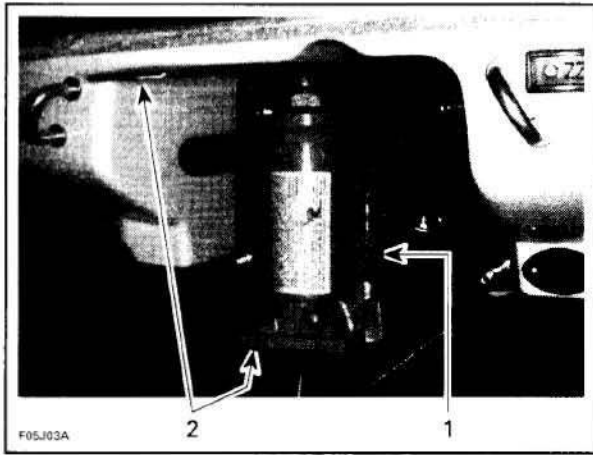

TYPICAL
1. Hydraulic bottle jack
2. Steel plates

Cleaning

Scrape off all excess of sealant from riding plate and hull.

Clean hull surface with acetone based solvent to eliminate grease, dust and any residue of sealant. Clean fitting threads.

Installation

All Models

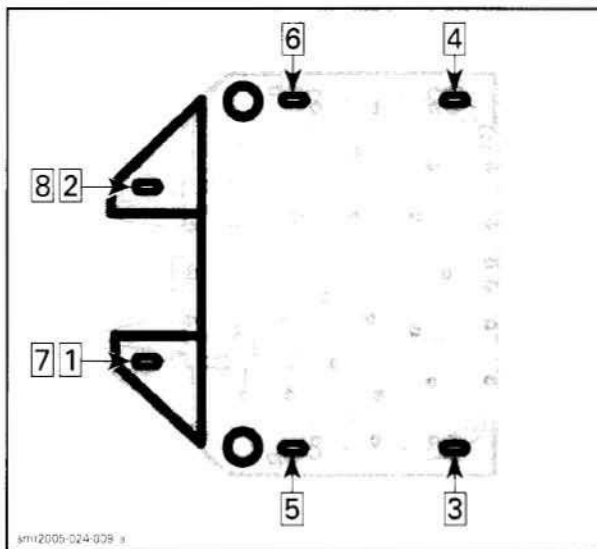

Properly reinstall hose fittings to ride plate. Apply Loctite 5900 (P/N 293 800 066) as indicated by the shaded areas in the previous illustrations. Follow also the torquing sequence as shown in the same illustration. Torque screws to 26 N•m (19 lbf•ft).

Reinstall hoses to ride plate and refill cooling system. Refer to *COOLING SYSTEM*.

JET PUMP SUPPORT

Removal

- Remove jet pump.
- Remove inlet grate and riding plate.
- Remove ball joint, boot, nut, half rings and O-rings from steering cable.

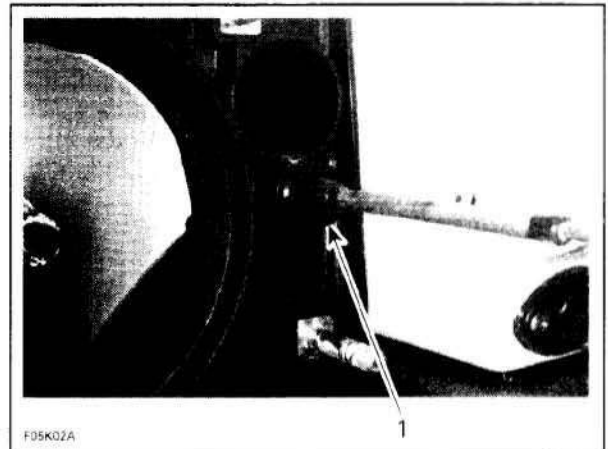

TYPICAL
1. Unscrew nut

Remove ball joint, boot, nut, half rings and O-rings from reverse cable.

Remove boot and nut from VTS sliding shaft (RXP models).

Disconnect water supply hose, water return hose and bailer hoses.

Remove nuts, lock washers and flat washers retaining jet pump support.

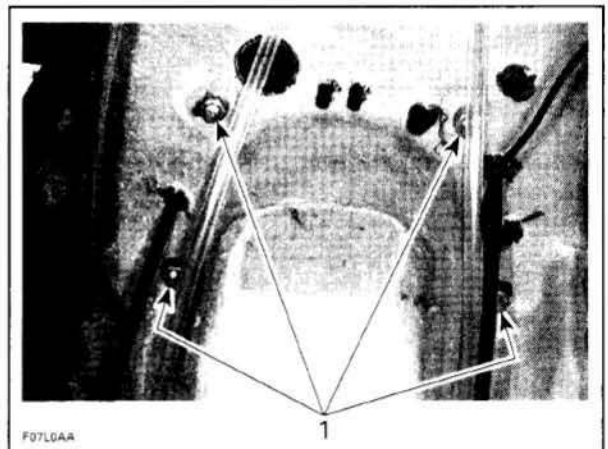

TYPICAL
1. Remove nuts

Using a heat gun, heat jet pump support until it is possible to pull it.

Section 10 TECHNICAL SPECIFICATIONS

Subsection 01 (GTI AND GTI SE)

MODEL		GTI	GTI SE
ENGINE (con'd)			
Cylinder head screw		Service limit	148.5 mm (5.846 in)
Cylinder head maximum warpage		Service limit	0.15 mm (.006 in)
Piston ring type and quantity		1 st	Upper compression ring, rectangular
		2 nd	Lower compression ring, tapered face
		3 rd	Oil scraper ring
Ring end gap	Rectangular	New	0.3 to 0.5 mm (.012 to .020 in)
	Taper-face		0.3 to 0.5 mm (.012 to .020 in)
	Oil scraper ring		0.3 to 0.5 mm (.012 to .020 in)
	All	Wear limit	1.0 mm (.039 in)
Ring/piston groove clearance	Rectangular	New	0.02 to 0.07 mm (.0008 to .0028 in)
	Taper-face		0.015 to 0.06 mm (.0006 to .0024 in)
	Oil scraper ring		0.02 to 0.055 mm (.0008 to .0021 in)
	All	Wear limit	0.15 mm (.006 in)
Piston/cylinder wall clearance		New	0.024 - 0.056 mm (.001 - .0022 in)
		Wear limit	0.1 mm (.0039 in)
Cylinder taper		Wear limit	0.1 mm (.0039 in)
Cylinder out of round (maximum)			0.015 mm (.0006 in)
Camshaft bearing journal	Front	New	24.93 to 24.96 mm (.9815 to .9827 in)
		Wear limit	24.93 mm (.9815 in)
	PTO and center	New	39.89 to 39.9 mm (1.5705 to 1.5709 in)
		Wear limit	39.88 mm (1.5701 in)
Camshaft bore	Front	New	25.00 to 25.01 mm (.9842 to .9846 in)
		Wear limit	25.02 mm (.9850 in)
	PTO and center	New	40.00 to 40.01 mm (1.5748 to 1.5752 in)
		Wear limit	40.02 mm (1.5756 in)
Cam lobe	Intake	New	31.48 to 31.68 mm (1.2394 to 1.2472 in)
		Wear limit	31.43 mm (1.2374 in)
	Exhaust	New	31.55 to 31.75 mm (1.2421 to 1.2499 in)
		Wear limit	31.65 mm (1.2461 in)
Crankshaft deflection		Maximum	0.050 mm (.002 in)
Crankshaft axial clearance		New	0.08 to 0.22 mm (.0031 to .0087 in)
		Wear limit	0.35 mm (.014 in)
Crankshaft journal diameter		New	49.991 to 50.000 mm (1.9681 to 1.9685 in)
		Wear limit	49.950 mm (1.9665 in)
Crankshaft radial clearance		Wear limit	0.007 mm (.0028 in)
Connecting rod big end diameter		Service limit	45.080 mm (1.7740 in)
Connecting rod big end clearance		Service limit	0.09 mm (.0039 in)
Connecting rod big end axial play		New	0.135 to 0.287 mm (.0053 to .0113 in)
		Wear limit	0.500 mm (.0197 in)
Connecting rod small end diameter		New	23.010 to 23.020 mm (.9059 to .9063 in)
		Wear limit	23.070 mm (.9080 in)

Section 10 TECHNICAL SPECIFICATIONS

Subsection 03 (GTX SUPERCHARGED AND GTX LIMITED)

MODEL		GTX SUPERCHARGED	GTX LIMITED
ENGINE (con'd)			
Cylinder head screw		Service limit	148.5 mm (5.846 in)
Cylinder head maximum warpage		Service limit	0.15 mm (.006 in)
Piston ring type and quantity		1 st	Upper compression ring, rectangular
		2 nd	Lower compression ring, tapered face
		3 rd	Oil scraper ring
Ring end gap	Rectangular	New	0.3 to 0.5 mm (.012 to .020 in)
	Taper-face		0.3 to 0.5 mm (.012 to .020 in)
	Oil scraper ring		0.3 to 0.5 mm (.012 to .020 in)
	All	Wear limit	1 mm (.039 in)
Ring/piston groove clearance	Rectangular	New	0.02 to 0.07 mm (.0008 to .0028 in)
	Taper-face		0.02 to 0.06 mm (.0008 to .0024 in)
	Oil scraper ring		0.02 to 0.055 mm (.0008 to .0021 in)
	All	Wear limit	0.15 mm (.006 in)
Piston/cylinder wall clearance		New	0.04 mm (.0016 in) 0.06 mm (.0023 in)
		Wear limit	0.1 mm (.0039 in)
Cylinder taper		Wear limit	0.1 mm (.0039 in)
Cylinder out of round		Service limit	0.015 mm (.0006 in)
Camshaft bearing journal	Front	New	24.93 to 24.96 mm (.9815 to .9827 in)
		Wear limit	24.93 mm (.9815 in)
	PTO and center	New	39.89 to 39.9 mm (1.5705 to 1.5709 in)
		Wear limit	39.88 mm (1.5701 in)
Camshaft bore	Front	New	25.00 to 25.01 mm (.9842 to .9846 in)
		Wear limit	25.02 mm (.9850 in)
	PTO and center	New	40.00 to 40.01 mm (1.5748 to 1.5752 in)
		Wear limit	40.02 mm (1.5756 in)
Cam lobe	Intake	New	31.65 to 31.85 mm (1.2460 to 1.2539 in) 31.54 to 31.74 mm (1.2417 to 1.2496 in)
		Wear limit	31.60 mm (1.2440 in) 31.49 mm (1.2397 in)
	Exhaust	New	31.43 to 31.63 mm (1.2373 to 1.2452 in)
		Wear limit	31.38 mm (1.2354 in)
Crankshaft deflection		Maximum	0.050 mm (.002 in)
Crankshaft axial clearance		New	0.08 to 0.22 mm (.0031 to .0087 in)
		Wear limit	0.35 mm (.014 in)
Crankshaft journal diameter		New	49.991 to 50.000 mm (1.9681 to 1.9685 in)
		Wear limit	49.950 mm (1.9665 in)
Crankshaft radial clearance		Wear limit	0.007 mm (.0028 in)
Connecting rod big end diameter		Service limit	45.080 mm (1.7740 in)
Connecting rod big end clearance		Service limit	0.09 mm (.0039 in)
Connecting rod big end axial play		New	0.135 to 0.287 mm (.0053 to .0113 in)
		Wear limit	0.500 mm (.0197 in)
Connecting rod small end diameter		New	23.010 to 23.020 mm (.9059 to .9063 in)
		Wear limit	23.070 mm (.9080 in)

Section 11 ELECTRICAL CONNECTORS AND WIRING DIAGRAM

Subsection 01 (ELECTRICAL CONNECTORS)

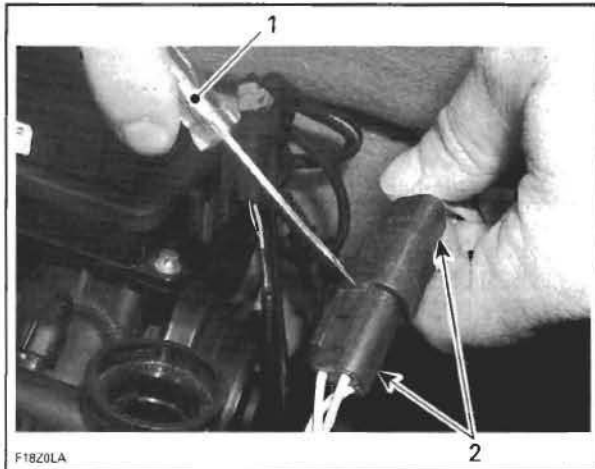

F1820LA

1. Flat screwdriver
2. Deutsch connectors

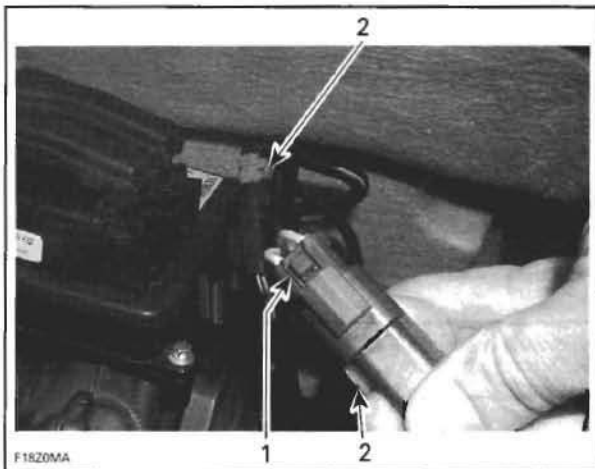

F1820MA

1. Release button
2. Deutsch connectors

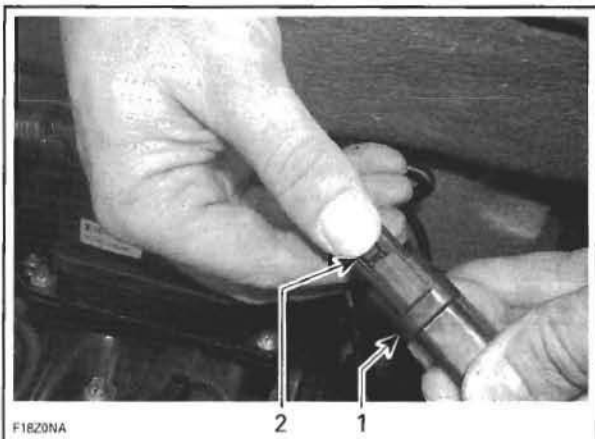

F1820NA

1. Deutsch connectors
2. Press release button

Connector Disassembly

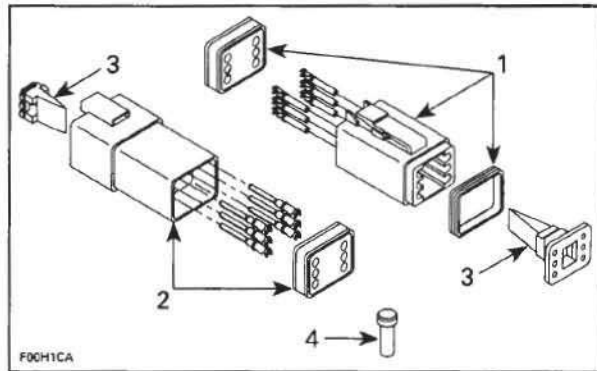

1. Male connector
2. Female connector
3. Secondary lock
4. Sealing cap

CAUTION: Do not apply dielectric grease on terminal inside connector.

To remove terminals from connector, proceed as follows:

- Using a long nose pliers, pull out the lock.

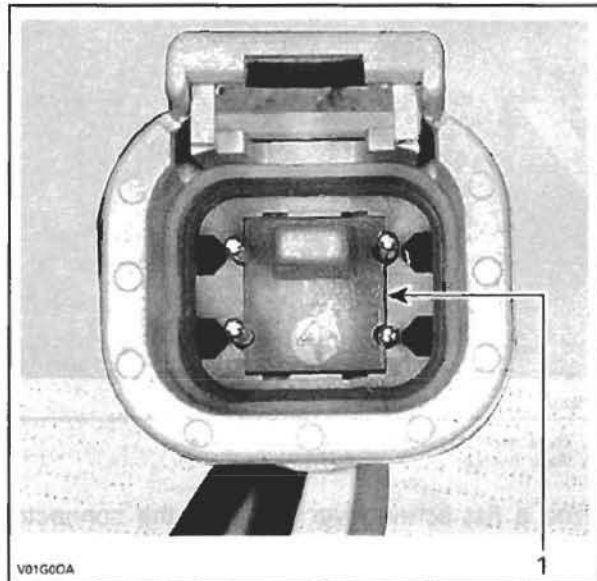

V01G0DA

- FEMALE CONNECTOR**
1. Female lock

CLICK HERE TO **DOWNLOAD** THE COMPLETE MANUAL

- Thank you very much for reading the preview of the manual.
- You can download the complete manual from: www.heydownloads.com by clicking the link below



- Please note: If there is no response to **CLICKING** the link, please download this PDF first and then click on it.

CLICK HERE TO **DOWNLOAD** THE COMPLETE MANUAL