

Edition: July 2005  
 Revision: October 2006  
 Publication No. SM6E-1A60U1

# NISSAN TITAN

MODEL A60 SERIES

## QUICK REFERENCE INDEX

<b>A GENERAL INFORMATION</b>	<b>GI General Information</b>
<b>B ENGINE</b>	<b>EM Engine Mechanical</b>
	<b>LU Engine Lubrication System</b>
	<b>CO Engine Cooling System</b>
	<b>EC Engine Control System</b>
	<b>FL Fuel System</b>
	<b>EX Exhaust System</b>
	<b>ACC Accelerator Control System</b>
<b>C TRANSMISSION/ TRANSAXLE</b>	<b>AT Automatic Transmission</b>
<b>D DRIVELINE/AXLE</b>	<b>TF Transfer</b>
	<b>PR Propeller Shaft</b>
	<b>FFD Front Final Drive</b>
	<b>RFD Rear Final Drive</b>
	<b>FAX Front Axle</b>
	<b>RAX Rear Axle</b>
<b>E SUSPENSION</b>	<b>FSU Front Suspension</b>
	<b>RSU Rear Suspension</b>
	<b>WT Road Wheels &amp; Tires</b>
<b>F BRAKES</b>	<b>BR Brake System</b>
	<b>PB Parking Brake System</b>
	<b>BRC Brake Control System</b>
<b>G STEERING</b>	<b>PS Power Steering System</b>
<b>H RESTRAINTS</b>	<b>SB Seat Belts</b>
	<b>SRS Supplemental Restraint System (SRS)</b>
<b>I BODY</b>	<b>BL Body, Lock &amp; Security System</b>
	<b>GW Glasses, Window System &amp; Mirrors</b>
	<b>RF Roof</b>
	<b>EI Exterior &amp; Interior</b>
	<b>IP Instrument Panel</b>
	<b>SE Seat</b>
	<b>AP Adjustable Pedal</b>
<b>J AIR CONDITIONER</b>	<b>ATC Automatic Air Conditioner</b>
	<b>MTC Manual Air Conditioner</b>
<b>K ELECTRICAL</b>	<b>SC Starting &amp; Charging System</b>
	<b>LT Lighting System</b>
	<b>DI Driver Information System</b>
	<b>WW Wiper, Washer &amp; Horn</b>
	<b>BCS Body Control System</b>
	<b>LAN LAN System</b>
	<b>AV Audio Visual, Navigation &amp; Telephone System</b>
	<b>ACS Auto Cruise Control System</b>
	<b>PG Power Supply, Ground &amp; Circuit Elements</b>
	<b>MA Maintenance</b>
<b>L MAINTENANCE</b>	<b>MA Maintenance</b>
<b>M INDEX</b>	<b>IDX Alphabetical Index</b>

**A**  
**B**  
**C**  
**D**  
**E**  
**F**  
**G**  
**H**  
**I**  
**J**  
**K**  
**L**  
**M**

© 2006 NISSAN NORTH AMERICA, INC.

All rights reserved. No part of this Service Manual may be reproduced or stored in a retrieval system, or transmitted in any form, or by any means, electronic, mechanical, photo-copying, recording or otherwise, without the prior written permission of Nissan North America, Inc.

CLICK HERE TO **DOWNLOAD** THE COMPLETE MANUAL

- Thank you very much for reading the preview of the manual.
- You can download the complete manual from: [www.heydownloads.com](http://www.heydownloads.com) by clicking the link below



- Please note: If there is no response to CLICKING the link, please download this PDF first and then click on it.

CLICK HERE TO **DOWNLOAD** THE COMPLETE MANUAL

# PRECAUTIONS

ECS00AVS

## Precautions

### NOTE:

If any malfunctions occur in the RE5R05A model transmission, replace the entire transmission assembly.

- Before connecting or disconnecting the TCM harness connector, turn ignition switch "OFF" and disconnect negative battery cable. Because battery voltage is applied to TCM even if ignition switch is turned "OFF".

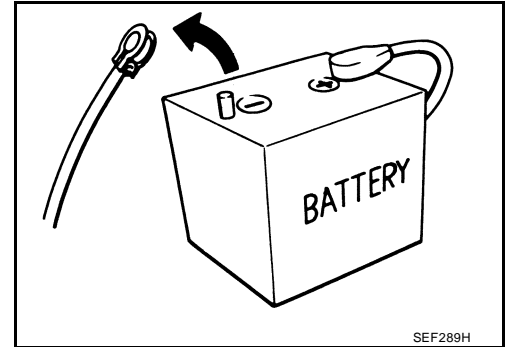

- After performing each TROUBLE DIAGNOSIS, perform "DTC (Diagnostic Trouble Code) CONFIRMATION PROCEDURE".  
If the repair is completed the DTC should not be displayed in the "DTC CONFIRMATION PROCEDURE".

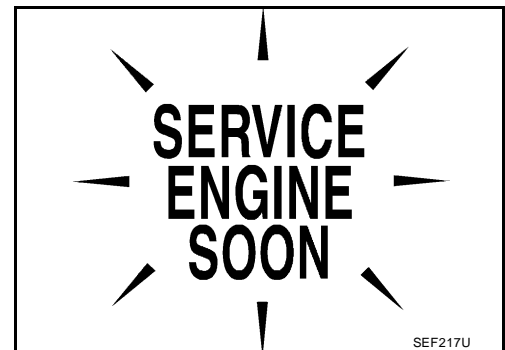

- Always use the specified brand of ATF. Refer to [MA-11, "RECOMMENDED FLUIDS AND LUBRICANTS"](#).
- Use paper rags not cloth rags during work.
- After replacing the ATF, dispose of the waste oil using the methods prescribed by law, ordinance, etc.
- Before proceeding with disassembly, thoroughly clean the outside of the transmission. It is important to prevent the internal parts from becoming contaminated by dirt or other foreign matter.
- Disassembly should be done in a clean work area.
- Use lint-free cloth or towels for wiping parts clean. Common shop rags can leave fibers that could interfere with the operation of the transmission.
- Place disassembled parts in order for easier and proper assembly.
- All parts should be carefully cleaned with a general purpose, non-flammable solvent before inspection or reassembly.
- Gaskets, seals and O-rings should be replaced any time the transmission is disassembled.
- It is very important to perform functional tests whenever they are indicated.
- The valve body contains precision parts and requires extreme care when parts are removed and serviced. Place disassembled valve body parts in order for easier and proper assembly. Care will also prevent springs and small parts from becoming scattered or lost.
- Properly installed valves, sleeves, plugs, etc. will slide along bores in valve body under their own weight.
- Before assembly, apply a coat of recommended ATF to all parts. Apply petroleum jelly to protect O-rings and seals, or hold bearings and washers in place during assembly. Do not use grease.
- Extreme care should be taken to avoid damage to O-rings, seals and gaskets when assembling.
- Clean or replace ATF cooler if excessive foreign material is found in oil pan or clogging strainer. Refer to [AT-14, "A/T Fluid Cooler Cleaning"](#).
- After overhaul, refill the transmission with new ATF.
- When the A/T drain plug is removed, only some of the fluid is drained. Old A/T fluid will remain in torque converter and ATF cooling system.  
Always follow the procedures under "Changing A/T Fluid" in the AT section when changing A/T fluid. Refer to [AT-12, "Changing A/T Fluid"](#), [AT-12, "Checking A/T Fluid"](#).

# TROUBLE DIAGNOSIS

## TROUBLE DIAGNOSIS

PFP:00004

### DTC Inspection Priority Chart

ECS00AWG

If some DTCs are displayed at the same time, perform inspections one by one based on the following priority chart.

#### NOTE:

If DTC U1000 is displayed with other DTCs, first perform the trouble diagnosis for DTC U1000. Refer to [AT-99](#).

Priority	Detected items (DTC)
1	U1000 CAN communication line
2	Except above

### Fail-Safe

ECS00AWH

The TCM has an electrical fail-safe mode. This mode makes it possible to operate even if there is an error in a main electronic control input/output signal circuit.

In fail-safe mode the transmission is fixed in 2nd, 4th, or 5th (depending on the breakdown position), so the customer should feel "slipping" or "poor acceleration".

Even when the electronic circuits are normal, under special conditions (for example, when slamming on the brake with the wheels spinning drastically and stopping the tire rotation), the transmission can go into fail-safe mode. If this happens, switch "OFF" the ignition switch for 10 seconds, then switch it "ON" again to return to the normal shift pattern. Therefore, the customer's vehicle has returned to normal, so handle according to the "diagnostics flow" (Refer to [AT-48, "WORK FLOW"](#)).

### FAIL-SAFE FUNCTION

If any malfunction occurs in a sensor or solenoid, this function controls the A/T to make driving possible.

#### Vehicle Speed Sensor

- Signals are input from two systems - from vehicle speed sensor A/T (revolution sensor) installed on the transmission and from combination meter so normal driving is possible even if there is a malfunction in one of the systems. And if vehicle speed sensor A/T (revolution sensor) has unusual cases, 5th gear and manual mode are prohibited.

#### Accelerator Pedal Position Sensor

- If there is a malfunction in one of the systems, the accelerator opening angle is controlled by ECM according to a pre-determined accelerator angle to make driving possible. And if there are malfunctions in tow systems, the engine speed is fixed by ECM to a pre-determined engine speed to make driving possible.

#### Throttle Position Sensor

- If there is a malfunction in one of the systems, the accelerator opening angle is controlled by ECM according to a pre-determined accelerator angle to make driving possible. And if there are malfunctions in tow systems, the accelerator opening angle is controlled by the idle signal sent from the ECM which is based on input indicating either idle condition or off-idle condition (pre-determined accelerator opening) in order to make driving possible.

#### PNP Switch

- In the unlikely event that a malfunction signal enters the TCM, the position indicator is switched "OFF", the starter relay is switched "OFF" (starter starting is disabled), the back-up lamp relay switched "OFF" (back-up lamp is OFF) and the position is fixed to the "D" range to make driving possible.

#### Starter Relay

- The starter relay is switched "OFF". (Starter starting is disabled.)

# TROUBLE DIAGNOSIS

No.	Items	Symptom	Condition	Diagnostic Item	Reference page
48		Shift point is low in D position.	ON vehicle	1. Vehicle speed sensor A/T and vehicle speed sensor MTR	<a href="#">AT-113</a> , <a href="#">AT-134</a>
				2. Accelerator pedal position sensor	<a href="#">AT-126</a>
				3. CAN communication line	<a href="#">AT-99</a>
				4. Control valve with TCM	<a href="#">AT-251</a>
49		Judder occurs during lock-up.	ON vehicle	1. Fluid level and state	<a href="#">AT-54</a>
				2. Engine speed signal	<a href="#">AT-118</a>
				3. Turbine revolution sensor	<a href="#">AT-111</a>
				4. Vehicle speed sensor A/T and vehicle speed sensor MTR	<a href="#">AT-113</a> , <a href="#">AT-134</a>
			OFF vehicle	5. Accelerator pedal position sensor	<a href="#">AT-126</a>
				6. CAN communication line	<a href="#">AT-99</a>
				7. Torque converter clutch solenoid valve	<a href="#">AT-120</a>
				8. Control valve with TCM	<a href="#">AT-251</a>
50	Others	Strange noise in "R" position.	ON vehicle	1. Fluid level and state	<a href="#">AT-54</a>
				2. Engine speed signal	<a href="#">AT-118</a>
				3. CAN communication line	<a href="#">AT-99</a>
				4. Control valve with TCM	<a href="#">AT-251</a>
			OFF vehicle	5. Torque converter	<a href="#">AT-285</a>
				6. Oil pump assembly	<a href="#">AT-303</a>
				7. Gear system	<a href="#">AT-271</a>
				8. High and low reverse clutch	<a href="#">AT-317</a>
				9. Reverse brake	<a href="#">AT-285</a>
51		Strange noise in "N" position.	ON vehicle	1. Fluid level and state	<a href="#">AT-54</a>
				2. Engine speed signal	<a href="#">AT-118</a>
				3. CAN communication line	<a href="#">AT-99</a>
				4. Control valve with TCM	<a href="#">AT-251</a>
			OFF vehicle	5. Torque converter	<a href="#">AT-285</a>
				6. Oil pump assembly	<a href="#">AT-303</a>
				7. Gear system	<a href="#">AT-271</a>
52		Strange noise in "D" position.	ON vehicle	1. Fluid level and state	<a href="#">AT-54</a>
				2. Engine speed signal	<a href="#">AT-118</a>
				3. CAN communication line	<a href="#">AT-99</a>
				4. Control valve with TCM	<a href="#">AT-251</a>
			OFF vehicle	5. Torque converter	<a href="#">AT-285</a>
				6. Oil pump assembly	<a href="#">AT-303</a>
				7. Gear system	<a href="#">AT-271</a>
				8. Forward brake (Parts behind drum support is impossible to perform inspection by disassembly. Refer to <a href="#">AT-17</a> , <a href="#">AT-18</a> .)	<a href="#">AT-285</a>

# DTC P0725 ENGINE SPEED SIGNAL

## 2. CHECK DTC WITH TCM

### With CONSULT-II

1. Start engine.
2. Select "ECU INPUT SIGNALS" in "DATA MONITOR" mode for "A/T" with CONSULT-II.
3. While monitoring engine speed, check for engine speed change corresponding to wide-open throttle position signal.

Item name	Condition	Display value (rpm)
ENGINE SPEED	Engine running	Closely matches the tachometer reading.

DATA MONITOR			
MONITOR	NO DTC		
W/O THL POS	OFF		
BRAKE SW	OFF		
ENGINE SPEED	0 rpm		
TURBINE REV	0 rpm		
OUTPUT REV	0 rpm		
▼			
RECORD			
MODE	BACK	LIGHT	COPY

PCIA0041E

### OK or NG

- OK >> GO TO 3.
- NG >> Check the ignition signal circuit.
  - Refer to [EC-611, "IGNITION SIGNAL"](#) .

## 3. CHECK DTC

Perform "DTC Confirmation Procedure".

- Refer to [AT-118, "DTC Confirmation Procedure"](#) .

### OK or NG

- OK >> **INSPECTION END**
- NG >> GO TO 4.

## 4. CHECK TCM POWER SUPPLY AND GROUND CIRCUIT

Check TCM power supply and ground circuit. Refer to [AT-173, "MAIN POWER SUPPLY AND GROUND CIRCUIT"](#) .

### OK or NG

- OK >> GO TO 5.
- NG >> Repair or replace damaged parts.

## 5. DETECT MALFUNCTIONING ITEM

Check the following items:

- The A/T assembly harness connector pin terminals for damage or loose connection with harness connector.

### OK or NG

- OK >> Replace the control valve with TCM. Refer to [AT-251, "Control Valve With TCM and A/T Fluid Temperature Sensor 2"](#) .
- NG >> Repair or replace damaged parts.

# DTC P1769 HIGH AND LOW REVERSE CLUTCH SOLENOID VALVE FUNCTION

## WITH GST

Follow the procedure "With CONSULT-II".

## Diagnostic Procedure

ECS00B10

### 1. CHECK INPUT SIGNALS

#### With CONSULT-II

1. Start the engine.
2. Select "SELECTION FROM MENU" in "DATA MONITOR" mode for "A/T" with CONSULT-II.
3. Drive vehicle in the "D" position (2nd ⇒ 3rd gear), and confirm the ON/OFF actuation of the "ATF PRES SW 6" and electrical current value of "HLR/C SOL".

DATA MONITOR			
MONITOR		NO DTC	
HLR/C SOL		XXX A	
ATF PRES SW 6		OFF	
		RECORD	
MODE	BACK	LIGHT	COPY

SCIA4798E

Item name	Condition	Display value (Approx.)
HLR/C SOL	High and low reverse clutch disengaged. Refer to <a href="#">AT-20</a> , <a href="#">AT-22</a> .	0.6 - 0.8 A
	High and low reverse clutch engaged. Refer to <a href="#">AT-20</a> , <a href="#">AT-22</a> .	0 - 0.05 A
ATF PRES SW 6	High and low reverse clutch engaged. Refer to <a href="#">AT-20</a> , <a href="#">AT-22</a> .	ON
	High and low reverse clutch disengaged. Refer to <a href="#">AT-20</a> , <a href="#">AT-22</a> .	OFF

#### OK or NG

- OK >> GO TO 4.  
NG >> GO TO 2.

### 2. CHECK TCM POWER SUPPLY AND GROUND CIRCUIT

Check TCM power supply and ground circuit. Refer to [AT-173, "MAIN POWER SUPPLY AND GROUND CIRCUIT"](#) .

#### OK or NG

- OK >> GO TO 3.  
NG >> Repair or replace damaged parts.

### 3. DETECT MALFUNCTIONING ITEM

Check the following items:

- The A/T assembly harness connector pin terminals for damage or loose connection with harness connector.

#### OK or NG

- OK >> Replace the control valve with TCM. Refer to [AT-251, "Control Valve With TCM and A/T Fluid Temperature Sensor 2"](#) .  
NG >> Repair or replace damaged parts.

### 4. CHECK DTC

Perform "DTC Confirmation Procedure".

- Refer to [AT-155, "DTC Confirmation Procedure"](#) .

#### OK or NG

- OK >> **INSPECTION END**  
NG >> GO TO 2.

# TROUBLE DIAGNOSIS FOR SYMPTOMS

## 9. CHECK A/T FLUID CONDITION

1. Remove oil pan. Refer to [AT-251, "Control Valve With TCM and A/T Fluid Temperature Sensor 2"](#) .
2. Check A/T fluid condition. Refer to [AT-54, "Fluid Condition Check"](#) .

OK or NG

- OK >> GO TO 10.
- NG >> GO TO 13.

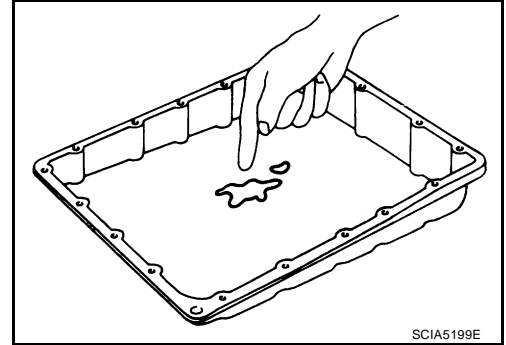

## 10. DETECT MALFUNCTIONING ITEM

- Check the malfunction items. If any items are damaged, repair or replace damaged parts. Refer to [AT-65, "Symptom Chart"](#) (Symptom No.43).

OK or NG

- OK >> GO TO 11.
- NG >> Repair or replace damaged parts.

## 11. CHECK SYMPTOM

Check again. Refer to [AT-58, "Check at Idle"](#) .

OK or NG

- OK >> **INSPECTION END**
- NG >> GO TO 12.

## 12. PERFORM TCM INSPECTION

1. Perform TCM input/output signals inspection. Refer to [AT-86, "TCM Input/Output Signal Reference Values"](#) .
2. If NG, recheck A/T assembly harness connector terminals for damage or loose connection with harness connector.

OK or NG

- OK >> **INSPECTION END**
- NG >> Repair or replace damaged parts.

## 13. DETECT MALFUNCTIONING ITEM

- Check the malfunction items. If any items are damaged, repair or replace damaged parts. Refer to [AT-65, "Symptom Chart"](#) (Symptom No.43).

OK or NG

- OK >> GO TO 11.
- NG >> Repair or replace damaged parts.

# TROUBLE DIAGNOSIS FOR SYMPTOMS

ECS00CCR

## A/T Does Not Shift: 2nd gear → 1st gear (Column Shift Models)

### SYMPTOM:

When shifted from 2M to 1M position in manual mode, does not downshift from 2nd to 1st gear.

### DIAGNOSTIC PROCEDURE

#### 1. CHECK SELF-DIAGNOSTIC RESULTS

Perform self-diagnosis. Refer to [AT-89, "SELF-DIAGNOSTIC RESULT MODE"](#) .

Do the self-diagnostic results indicate PNP switch, ATF pressure switch 5?

- YES >> Check the malfunctioning system. Refer to [AT-107, "DTC P0705 PARK/NEUTRAL POSITION SWITCH"](#) , [AT-169, "DTC P1845 ATF PRESSURE SWITCH 5"](#) .
- NO >> GO TO 2.

#### 2. CHECK A/T FLUID LEVEL

Check A/T fluid level. Refer to [AT-12, "Checking A/T Fluid"](#) .

OK or NG

- OK >> GO TO 3.
- NG >> Refill ATF.

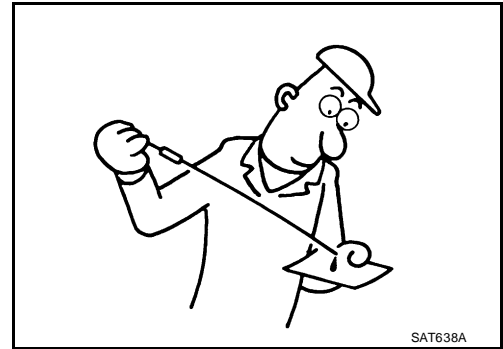

#### 3. CHECK CONTROL LINKAGE

Check the control linkage.

- Refer to [AT-237, "Checking of A/T Position"](#) .

OK or NG

- OK >> GO TO 4.
- NG >> Adjust control linkage. Refer to [AT-237, "Adjustment of A/T Position"](#) .

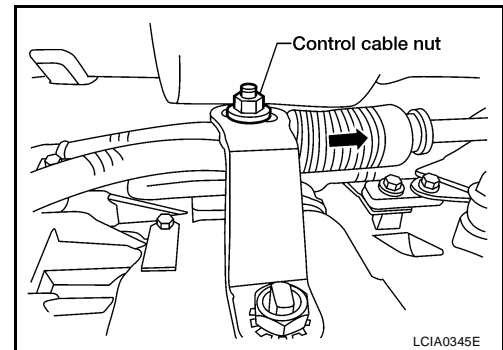

#### 4. MANUAL MODE SWITCH

Check the manual mode switch. Refer to [AT-161, "DTC P1815 MANUAL MODE SWITCH"](#) .

OK or NG

- OK >> GO TO 5.
- NG >> Repair or replace damaged parts.

# TRANSMISSION ASSEMBLY

ECS00EQQ

## Removal and Installation (4WD) COMPONENTS

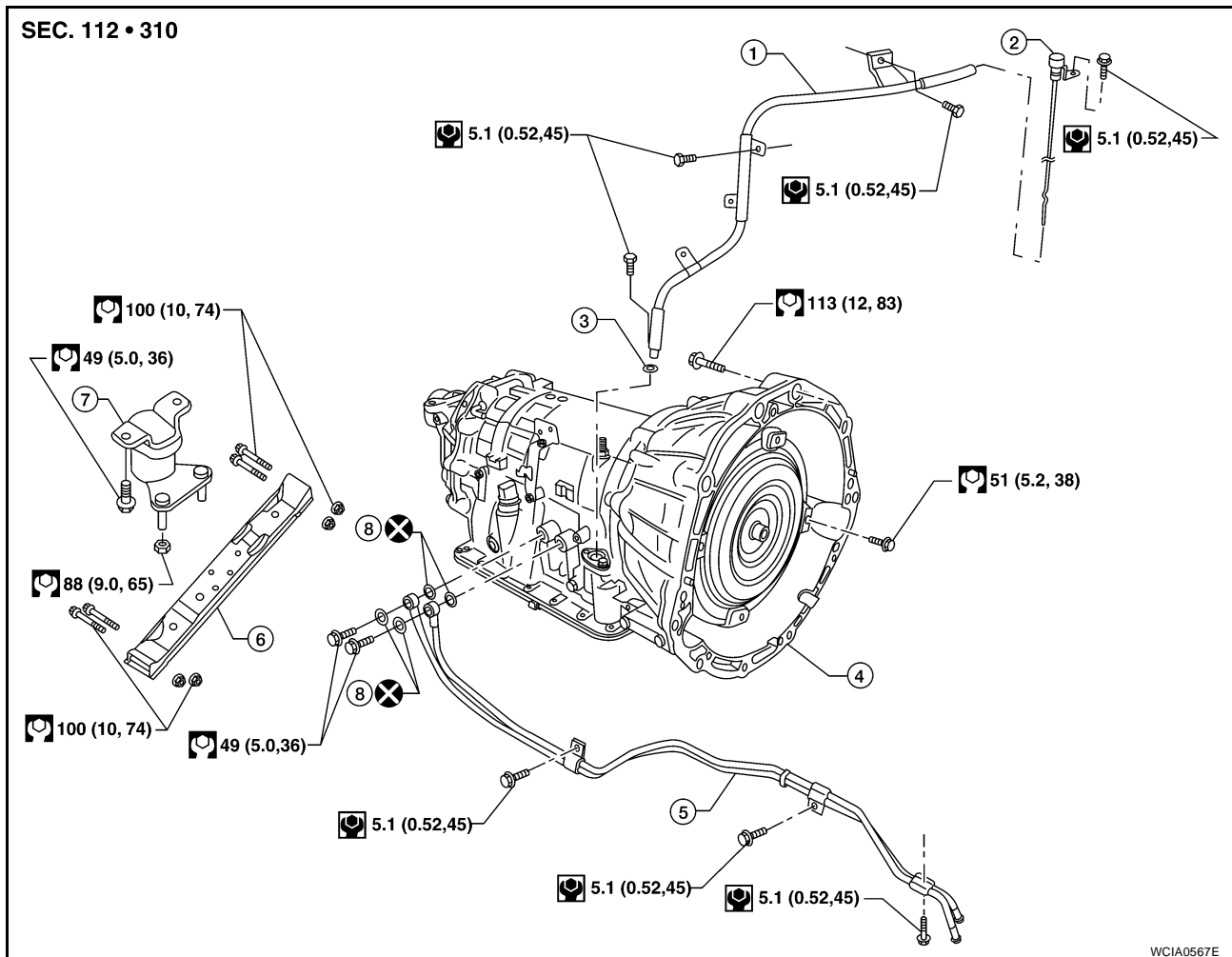

- |                             |                        |                  |
|-----------------------------|------------------------|------------------|
| 1. A/T fluid indicator pipe | 2. A/T fluid indicator | 3. O-ring        |
| 4. Transmission assembly    | 5. Fluid cooler tube   | 6. Copper washer |
| 7. A/T cross member         | 8. Insulator           |                  |

### REMOVAL

#### CAUTION:

When removing the A/T assembly from engine, first remove the crankshaft position sensor (POS) from the A/T assembly.

Be careful not to damage sensor edge.

1. Disconnect the negative battery terminal.
2. Remove engine cover using power tool.
3. Remove A/T fluid indicator.
4. Remove undercovers using power tool.
5. Remove exhaust front tube and center muffler using power tool. Refer to [EX-4, "REMOVAL"](#).
6. Remove propeller shafts. Refer to [PR-5, "REMOVAL"](#) and [PR-9, "REMOVAL"](#).
7. Remove A/T control cable. Refer to [AT-236, "REMOVAL"](#).

## REPAIR FOR COMPONENT PARTS

3. Remove O-ring from oil pump housing.

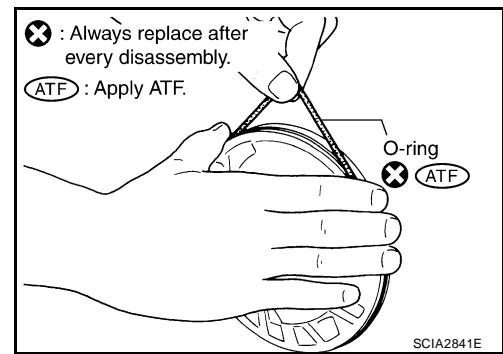

4. Remove O-ring from oil pump cover.

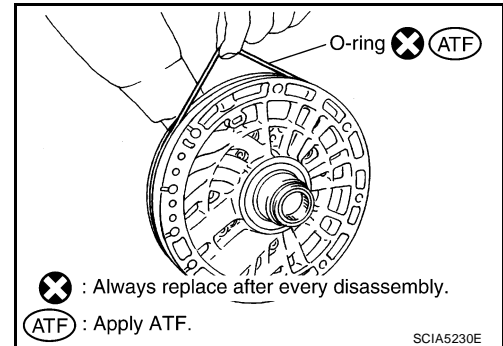

### ASSEMBLY

1. Install new O-ring to oil pump cover.

**CAUTION:**

- Do not reuse O-ring.
- Apply ATF to O-ring.

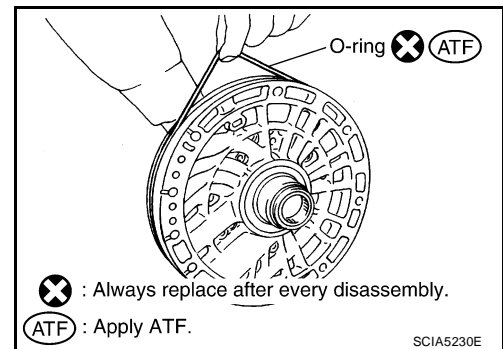

2. Install new O-ring to oil pump housing.

**CAUTION:**

- Do not reuse O-ring.
- Apply ATF to O-ring.

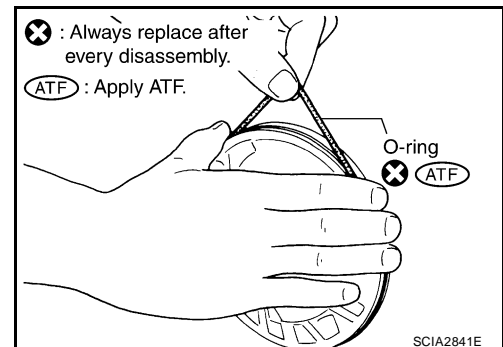

# ASSEMBLY

11. Securely fasten terminal cord assembly and A/T fluid temperature sensor 2 harness with terminal clips.

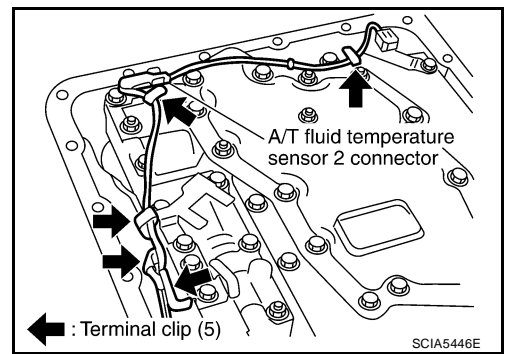

12. Connect revolution sensor connector.

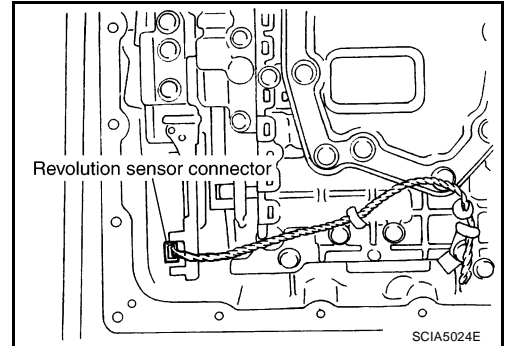

13. Securely fasten revolution sensor harness with terminal clips.

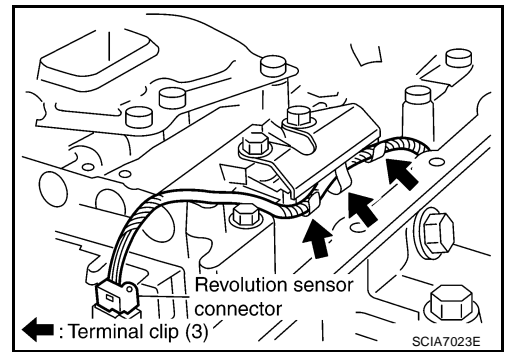

14. Pull down A/T assembly harness connector.

**CAUTION:**  
Be careful not to damage connector.

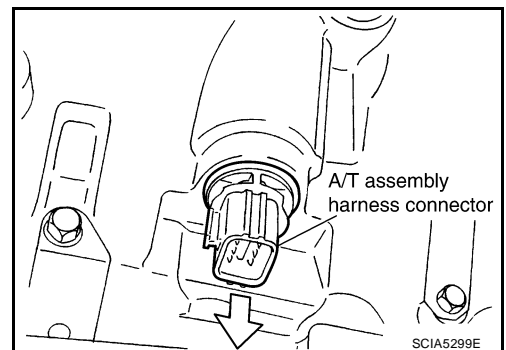

15. Install snap ring to A/T assembly harness connector.

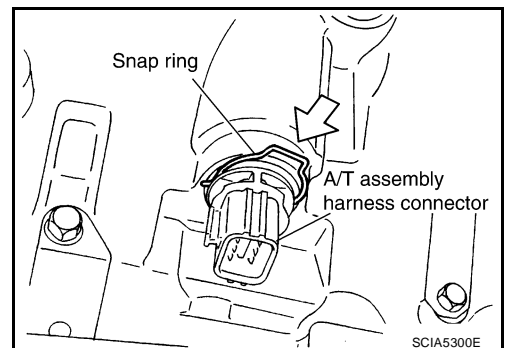

A  
B  
AT  
D  
E  
F  
G  
H  
I  
J  
K  
L  
M

# TROUBLE DIAGNOSIS

## Display Item List

Monitor item	Value	Contents
BATT VIA CAN	"V"	Displays battery voltage signal.
IGN VIA CAN	"ON/OFF"	Displays ignition switch signal.
DVR SUNLD SEN	"w/m2"	Displays optical sensor (driver) signal.
PAS SUNLD SEN	"w/m2"	Displays optical sensor (passenger) signal.
AMB TEMP SEN	"°C/°F"	Displays ambient sensor signal.
EVAP TEMP SEN	"°C/°F"	Displays intake sensor signal.
INCAR TMP SEN	"°C/°F"	Displays in-vehicle sensor signal.
RR TEMPSET FR	"V"	Displays air mix door (front) set point signal.
MODE FDBCK	"V"	Displays mode door motor feedback signal.
DVR MIX FDBCK	"V"	Displays air mix door motor (driver) feedback signal.
PAS MIX FDBCK	"V"	Displays air mix door motor (passenger) feedback signal.
DEF FDBCK	"V"	Displays defroster door motor feedback signal.
RECIRC	"ON/OFF"	Displays recirculation switch signal.
DEFROST	"ON/OFF"	Displays defroster switch signal.
AUTO	"ON/OFF"	Displays AUTO switch signal.
A/C	"ON/OFF"	Displays A/C switch signal.
MODE	"ON/OFF"	Displays MODE switch signal.
L TEMP UP	"ON/OFF"	Displays driver side temperature control dial (temp increase) signal.
L TEMP DOWN	"ON/OFF"	Displays driver side temperature control dial (temp decrease) signal.
RR DEFOG	"ON/OFF"	Displays rear defroster request signal.
FANUP	"ON/OFF"	Displays front blower motor (blower speed increase) signal.
FANDOWN	"ON/OFF"	Displays front blower motor (blower speed decrease) signal.
MODE SELECT	" [ PNL ]" " [ MIX ]" " [ FLR ]" " [ DEFR ]" " [ MAX ]" " [ DENT ]"	Displays mode door motor position.

\*: DENT is displayed when MODE switch is between selections.

# TROUBLE DIAGNOSIS

## SYSTEM DESCRIPTION

### Component Parts

Mode door control system components are:

- Front air control
- Mode door motor
- PBR (built into mode door motor)
- In-vehicle sensor
- Ambient sensor
- Optical sensor
- Intake sensor

### System Operation

The mode door position (vent, B/L, foot, D/F, and defrost) is set by the front air control by means of the mode door motor. When a mode door position is selected on the front air control, voltage is applied to one circuit of the mode door motor while ground is applied to the other circuit, causing the mode door motor to rotate. The direction of rotation is determined by which circuit has voltage applied to it, and which one has ground applied to it. The front air control monitors the mode door position by measuring the voltage signal on the PBR circuit. In AUTO mode the mode door position is set by the front air control which determines the proper position based on inputs from the in-vehicle sensor, ambient sensor, optical sensor, intake sensor, and the temperature selected by the driver or passenger.

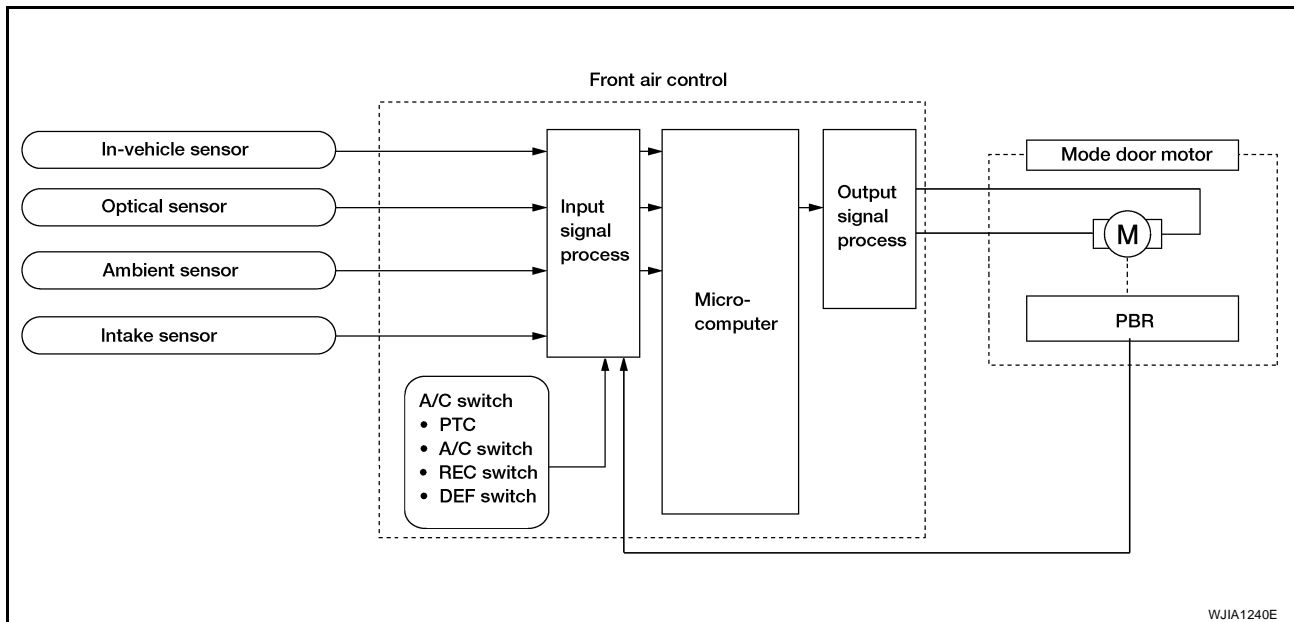

### Mode Door Control Specification

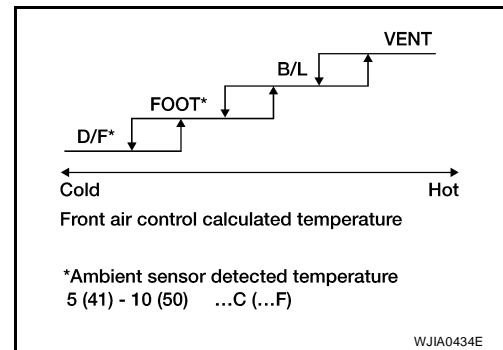

# TROUBLE DIAGNOSIS

## 20. CHECK PBR REFERENCE VOLTAGE CIRCUIT FOR SHORT TO GROUND

1. Turn ignition switch OFF.
2. Disconnect the front air control harness connector.
3. Check continuity between front air control harness connector M49 terminal 23 and ground.

**Continuity should not exist.**

OK or NG

- OK >> Replace front air control. Refer to [ATC-159, "REMOVAL"](#).
- NG >> Repair or replace harness as necessary.

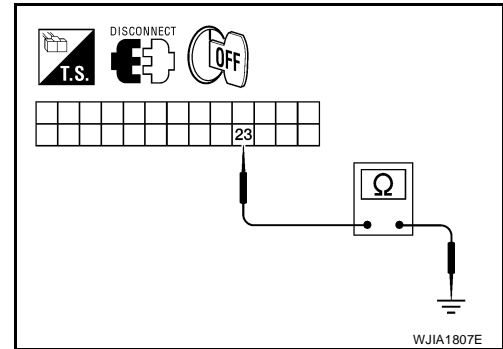

## 21. CHECK PBR REFERENCE VOLTAGE AND GROUND CIRCUITS

1. Turn ignition switch OFF.
2. Disconnect the front air control harness connector.
3. Check continuity between front air control harness connector M49 terminal 23 and terminal 26.

**Continuity should exist.**

OK or NG

- OK >> GO TO 23.
- NG >> GO TO 22.

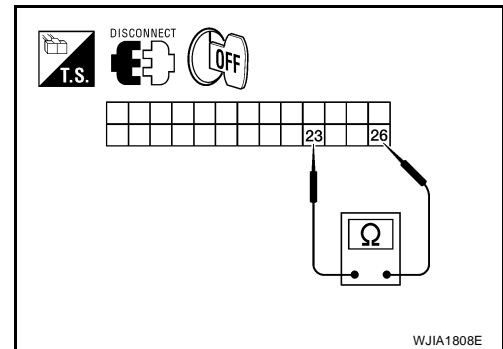

## 22. CHECK PBR REFERENCE VOLTAGE CIRCUIT FOR OPEN

1. Disconnect the defroster door motor harness connector.
2. Check continuity between defroster door motor harness connector M144 (B) terminal 3, 2 and front air control harness connector M49 (A) terminal 23, 26.

**23 - 3 : Continuity should exist.**

**26 - 2 : Continuity should exist.**

OK or NG

- OK >> Replace defroster door motor. Refer to [ATC-171, "DEFROSTER DOOR MOTOR"](#).
- NG >> Repair or replace harness as necessary.

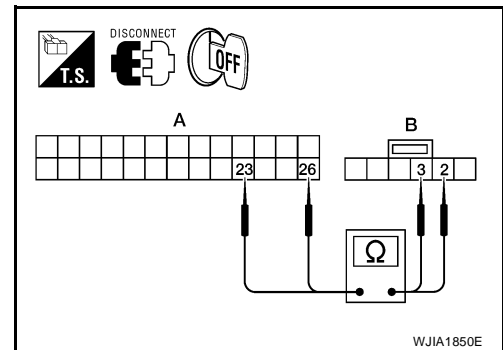

## 23. CHECK PBR FEEDBACK VOLTAGE

1. Reconnect the front air control harness connector.
2. Turn ignition switch ON.
3. Check voltage between front air control harness connector M49 terminal 7 and ground while cycling defroster switch on and off.

**Voltage : Approx. 1V - 4.5V**

OK or NG

- OK >> GO TO 25.
- NG >> GO TO 24.

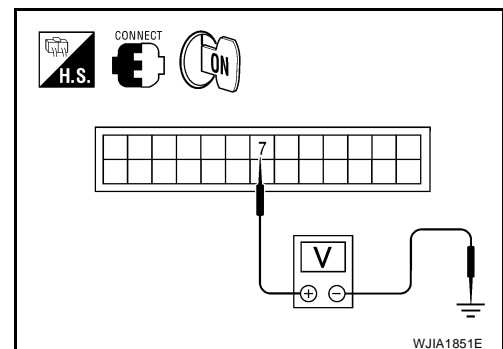

# TROUBLE DIAGNOSIS

EJS004V1

## Ambient Sensor Circuit COMPONENT DESCRIPTION

### Ambient Sensor

The ambient sensor is attached on the radiator core support (left side). It detects ambient temperature and converts it into a value which is then input into the front air control.

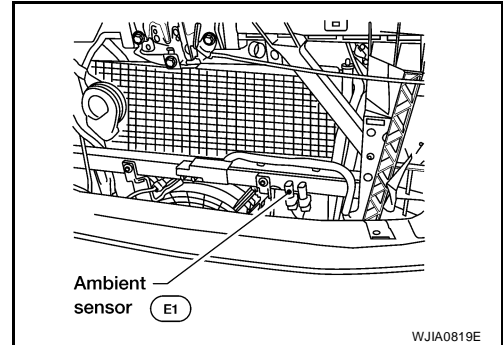

### AMBIENT TEMPERATURE INPUT PROCESS

The front air control includes a processing circuit for the ambient sensor input. However, when the temperature detected by the ambient sensor increases quickly, the processing circuit retards the front air control function. It only allows the front air control to recognize an ambient temperature increase of 0.33°C (0.6°F) per 100 seconds.

This prevents constant adjustments due to momentary conditions, such as stopping after high speed driving. Although the actual ambient temperature has not changed, the temperature detected by the ambient sensor will increase. This is because the heat from the engine compartment can radiate to the front grille area, location of the ambient sensor.

### DIAGNOSTIC PROCEDURE FOR AMBIENT SENSOR

SYMPTOM: Ambient sensor circuit is open or shorted. Using the CONSULT-II, DTC B257B or B257C is displayed. Without a CONSULT-II, code 40 or 41 is indicated on front air control as a result of conducting the front air control self-diagnosis.

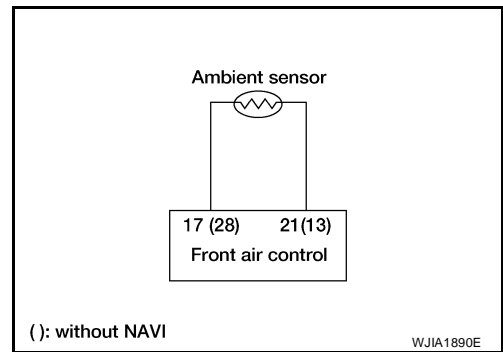

## 1. CHECK VEHICLE EQUIPMENT

Is vehicle equipped with navi?

YES or NO

- YES >> GO TO 2.
- NO >> GO TO 6.

## 2. CHECK VOLTAGE BETWEEN AMBIENT SENSOR AND GROUND

1. Disconnect ambient sensor connector.
2. Turn ignition switch ON.
3. Check voltage between ambient sensor harness connector E1 terminal 1 and ground.

**1 - Ground : Approx. 5V**

OK or NG

- OK >> GO TO 3.
- NG >> GO TO 5.

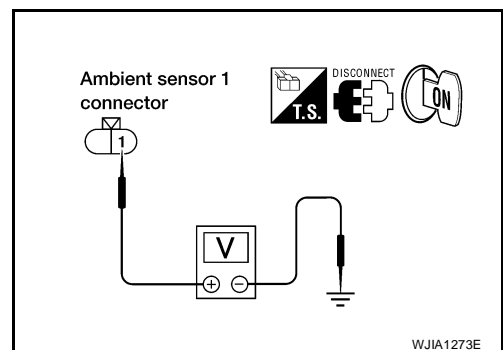

A  
B  
C  
D  
E  
F  
G  
H  
I  
ATC  
K  
L  
M

# REFRIGERANT LINES

PF9:92600

EJS004VQ

## REFRIGERANT LINES

### HFC-134a (R-134a) Service Procedure SETTING OF SERVICE TOOLS AND EQUIPMENT Discharging Refrigerant

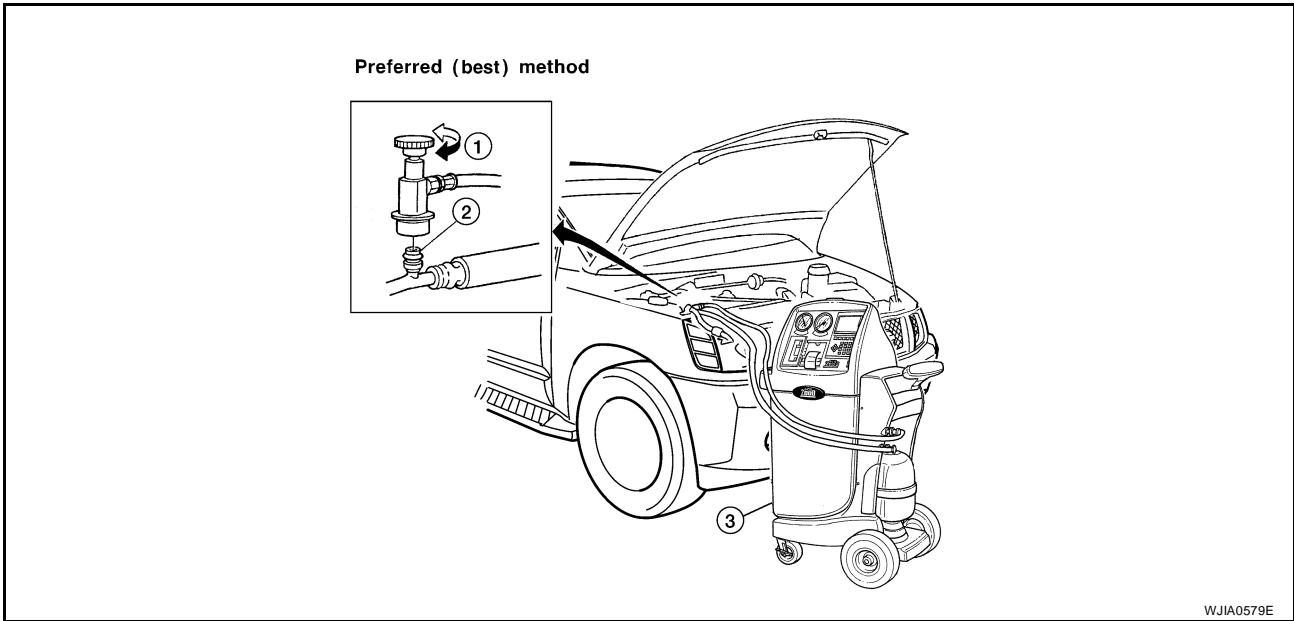

WJIA0579E

1. Shut-off valve
2. A/C service valve
3. Recovery/recycling equipment

#### **WARNING:**

Avoid breathing A/C refrigerant and oil vapor or mist. Exposure may irritate eyes, nose and throat. Remove HFC-134a (R-134a) refrigerant from the A/C system using certified service equipment meeting requirements of SAE J2210 HFC-134a (R-134a) recycling equipment or SAE J2201 HFC-134a (R-134a) recovery equipment. If an accidental system discharge occurs, ventilate the work area before resuming service. Additional health and safety information may be obtained from the refrigerant and oil manufacturers.

### Evacuating System and Charging Refrigerant

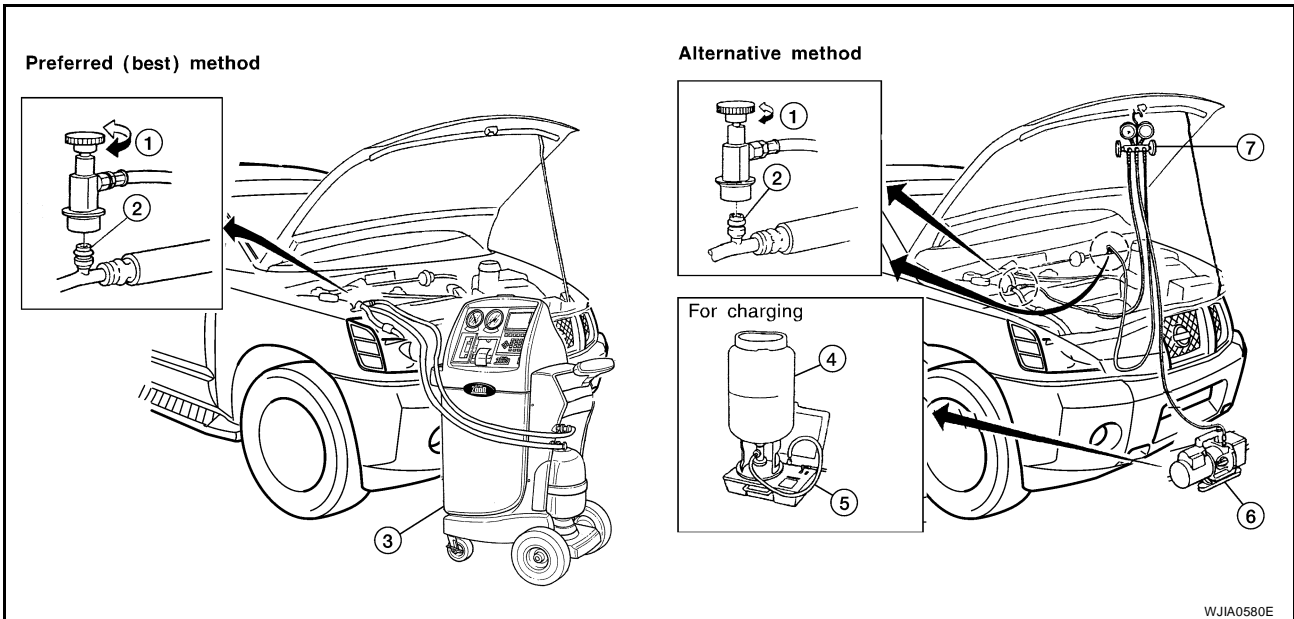

WJIA0580E

1. Shut-off valve
2. A/C service valve
3. Recovery/recycling equipment
4. Refrigerant container (HFC-134a)
5. Weight scale (J-39650)
6. Evacuating vacuum pump (J-39699)
7. Manifold gauge set (J-39183)



# AUDIO

## 4. CHECK STEERING SWITCH RESISTANCE

Check resistance between steering switch terminals.

Terminal	Signal name	Condition	Resistance (Ω) (Approx.)	
16	17	Seek (down)	Depress (station) down switch.	165
		Power	Depress power switch.	0
		Volume (down)	Depress volume down switch.	652
20	17	Seek (up)	Depress (station) up switch.	165
		Mode	Depress mode switch.	0
		Volume (up)	Depress volume up switch.	652

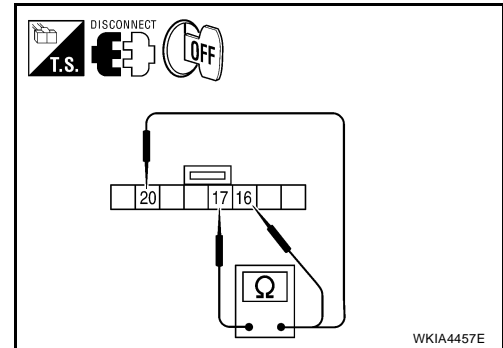

OK or NG

OK >> Inspection End.

NG >> Replace steering switch. Refer to [AV-78, "STEERING WHEEL AUDIO CONTROL SWITCHES"](#).

### AV Switch Check

EKS00A0D

#### 1. AV SWITCH SELF-DIAGNOSIS FUNCTION CHECK

Perform AV switch self-diagnosis function. Refer to [AV-47, "AV Switch Self-Diagnosis Function"](#).

Does AV switch operate normally?

YES >> Inspection End.

NO >> GO TO 2.

#### 2. CHECK AV SWITCH POWER SUPPLY AND GROUND CIRCUIT

Check AV switch power supply and ground circuit. Refer to [AV-135, "Power Supply and Ground Circuit Check for AV Switch"](#).

OK or NG

YES >> Replace AV switch. Refer to [AV-74, "AV SWITCH"](#).

NO >> Repair malfunctioning part.

### Audio Communication Line Check (With Navigation System)

EKS00A0E

#### 1. CHECK AUDIO COMMUNICATION LINE

Start audio communication line check. Refer to [AV-140, "Audio Communication Line Check \(Between Display Control Unit and Audio Unit\)"](#).

OK or NG

OK >> Inspection End.

NG >> Replace malfunctioning part.

# NAVIGATION SYSTEM

AV-NAVI-02

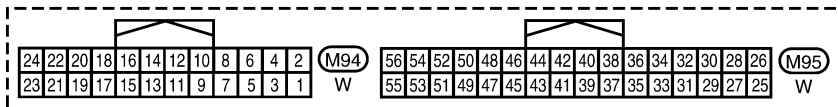
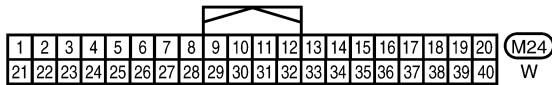
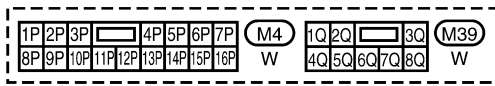
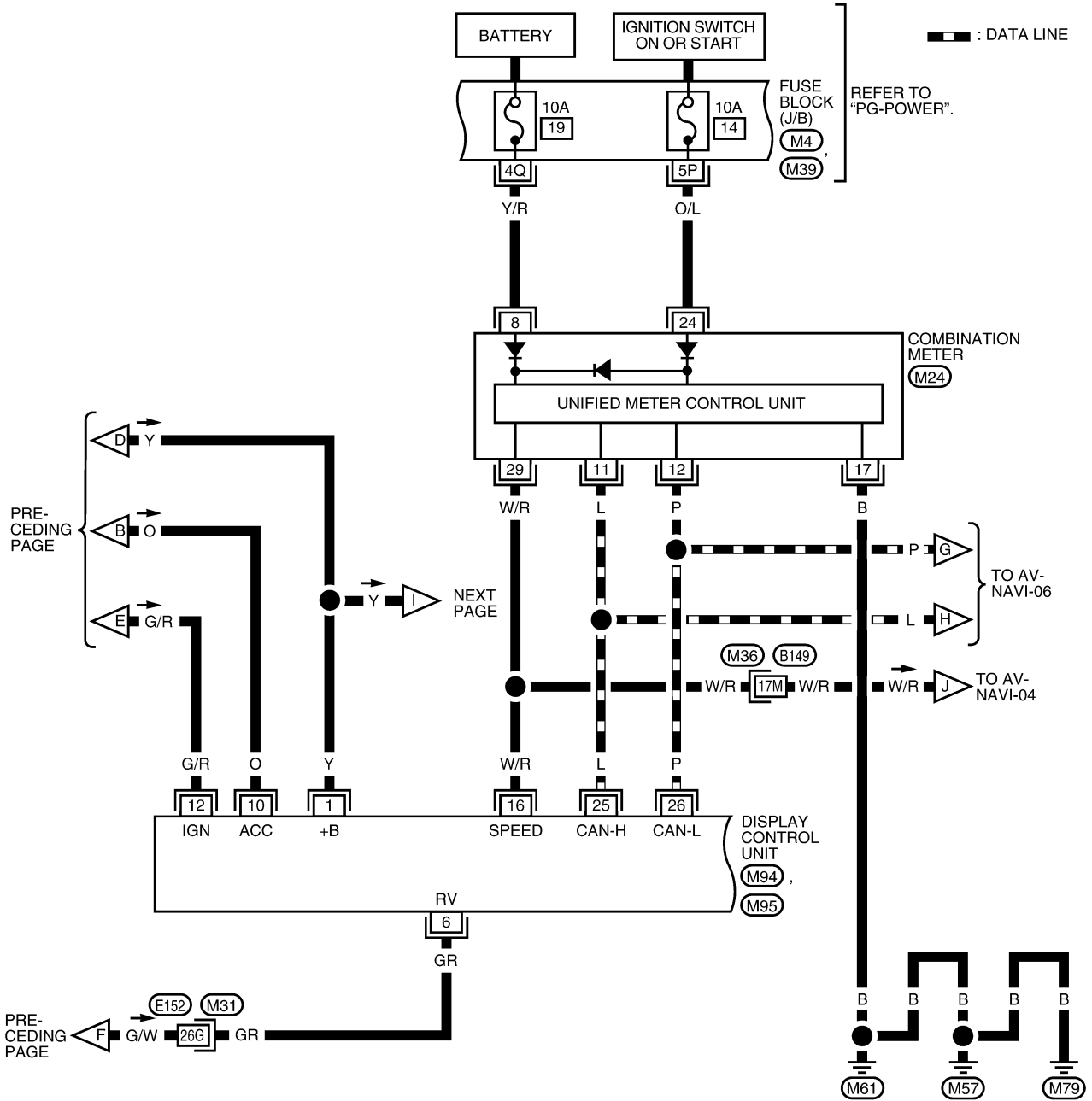

REFER TO THE FOLLOWING.  
 (M31), (M36) - SUPER  
 MULTIPLE JUNCTION (SMJ)

WKWA3742E

# NAVIGATION SYSTEM

EKS00GJ4

## Power Supply and Ground Circuit Check for Display Control Unit

### 1. CHECK FUSE

Make sure the following fuses of the display control unit are not blown.

Terminals		Power source	Fuse No.
Connector	Terminal		
M94	1	Battery power	31
	10	ACC power	4

OK or NG

OK >> GO TO 2.

NG >> If fuse is blown, be sure to eliminate cause of malfunction before installing new fuse. Refer to [PG-4, "POWER SUPPLY ROUTING CIRCUIT"](#) .

### 2. CHECK POWER SUPPLY CIRCUIT

1. Disconnect display control unit connector M94.
2. Check voltage between connector terminals and ground as follows.

Terminals		Ignition switch position		
(+)	(-)			
Connector	Terminal	OFF	ACC	ON
M94	1	Battery voltage	Battery voltage	Battery voltage
	10	0V	Battery voltage	Battery voltage

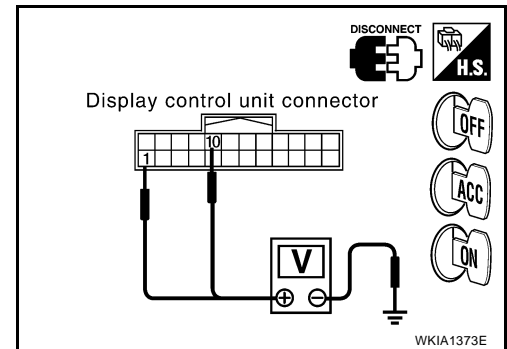

OK or NG

OK >> GO TO 3.

NG >> Check harness for open between display control unit and fuse.

### 3. CHECK GROUND CIRCUIT

Check continuity between the following display control unit connector terminals and ground.

Terminals		Ignition switch	Continuity	
Connector	Terminal			
M94	3	Ground	OFF	Yes

OK or NG

OK >> Inspection End.

NG >> Repair or replace harness.

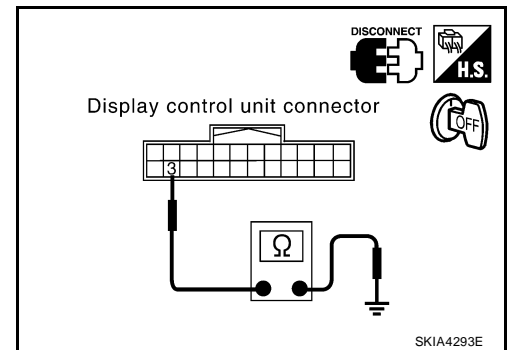

# NAVIGATION SYSTEM

---

## CURRENT-LOCATION MARK IS IN A RIVER OR SEA

The navigation system moves the current-location mark with no distinction between land and rivers or sea. If the location mark is somehow out of place, it may appear that the vehicle is driving in a river or the sea.

## WHEN DRIVING ON SAME ROAD, SOMETIMES CURRENT-LOCATION MARK IS IN RIGHT PLACE AND SOMETIMES IT IS WRONG PLACE

The conditions of the GPS antenna (GPS data) and gyroscope (angular speed sensor) change gradually. Depending on the road traveled and the operation of the steering wheel, the location detection results will be different. Therefore, even on a road on which the location has never been wrong, conditions may cause the vehicle mark to deviate.

## LOCATION CORRECTION BY MAP-MATCHING IS SLOW

- The map-matching function needs to refer to the data of the surrounding area. It is necessary to drive some distance for the function to work.
- Because map-matching operates on this principle, when there are many roads running in similar directions in the surrounding area, no matching determination may be made. The location may not be corrected until some special feature is found.

## ALTHOUGH GPS RECEIVING DISPLAY IS GREEN, VEHICLE MARK DOES NOT RETURN TO CORRECT LOCATION

- The GPS accuracy has an error of approximately 10 m (30 ft). In some cases the current-location mark may not be on the correct street, even when GPS location-correction is done.
- The navigation system compares the results of GPS location detection with the results from map-matching location detection. The one which is determined to have higher accuracy is used.
- GPS location correction may not be performed when the vehicle is stopped.

## NAME OF CURRENT PLACE IS NOT DISPLAYED

The current place name may not be displayed if there are no place names displayed on the map screen.

## CONTENTS OF DISPLAY DIFFER FOR BIRDVIEW™ AND THE (FLAT) MAP SCREEN

Difference of the BIRDVIEW™ screen from the flat map screen are as follows.

- The current place name displays names which are primarily in the direction of vehicle travel.
- The amount of time before the vehicle travel or turn angle is updated on the screen is longer than for the (flat) map display.
- The conditions for display of place names, roads, and other data are different for nearby areas and for more distant areas.
- Some thinning of the character data is done to prevent the display becoming too complex. In some cases and in some locations, the display contents may differ.
- The same place name, street name, etc. may be displayed multiple times.

A  
B  
C  
D  
E  
F  
G  
H  
I  
J  
AV  
L  
M

# HOOD

## Removal and Installation of Hood Lock Control

EIS0048S

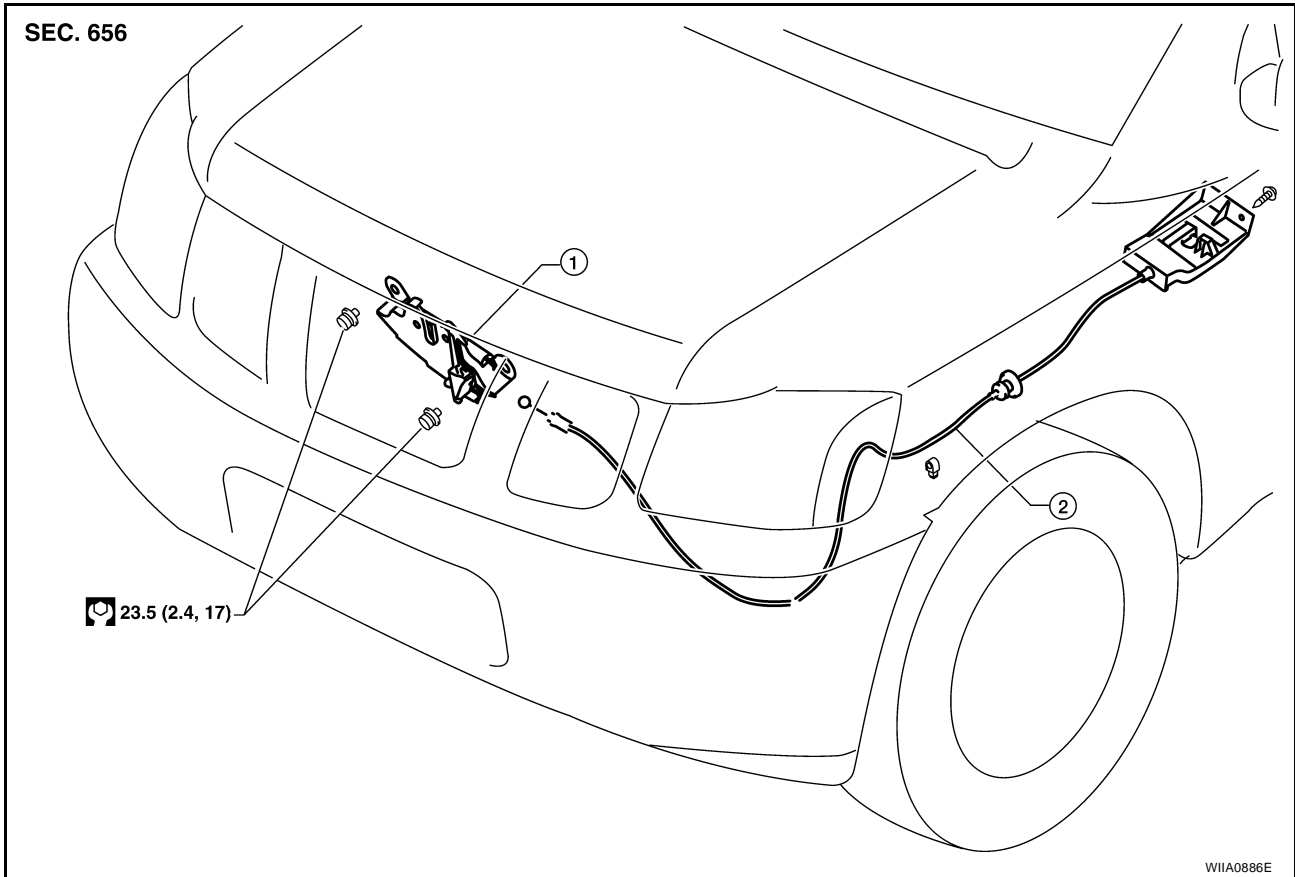

1. Hood lock assembly

2. Hood lock cable

### REMOVAL

1. Remove the front grill. Refer to [EI-20, "FRONT GRILLE"](#).
2. Remove the front fender protector (LH). Refer to [EI-24, "FENDER PROTECTOR"](#).
3. Disconnect the hood lock cable from the hood lock, and unclip it from the radiator core support upper and hoodedge.
4. Remove the bolt and the hood opener.
5. Remove the grommet from the dash lower, and pull the hood lock cable toward the passenger room.

### CAUTION:

**While pulling, be careful not to damage the outside of the hood lock cable.**

# POWER DOOR LOCK SYSTEM

EIS0049D

## Door Lock Actuator Check (Rear RH/LH)

### 1. CHECK DOOR LOCK ACTUATOR SIGNAL

Check voltage between BCM connector M20 terminals 65, 66 and ground.

Con- nec- tor	Terminals		Condition	Voltage (V) (Approx.)
	(+)	(-)		
M20	65	Ground	Door lock/unlock switch is turned to LOCK	0 → Battery voltage
	66		Door lock/unlock switch is turned to UNLOCK	0 → Battery voltage

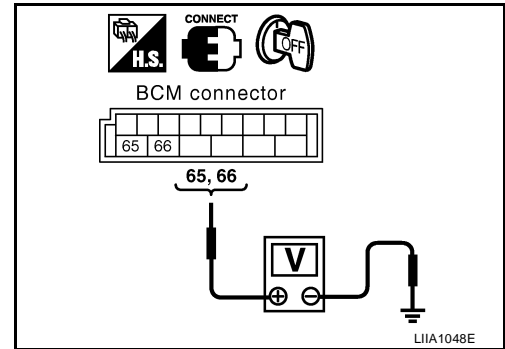

OK or NG

- OK >> GO TO 2.
- NG >> Replace BCM. Refer to [BCS-20, "BCM"](#).

### 2. CHECK DOOR LOCK ACTUATOR HARNESS

1. Disconnect BCM and inoperative door lock actuator.
2. Check continuity between BCM connector M20 terminals 65, 66 and rear door lock actuator connector terminals 2, 3.

Terminals		Continuity
65	3	Yes
66	2	Yes

3. Check continuity between BCM connector M20 terminals 65, 66 and ground.

Terminals		Continuity
65	Ground	No
66		No

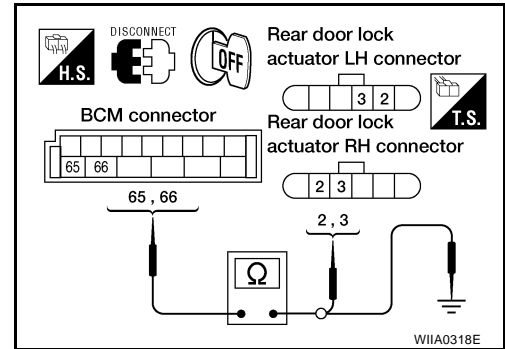

OK or NG

- OK >> Replace door lock actuator. Refer to [BL-134, "Removal and Installation"](#).
- NG >> Repair or replace harness.

# REMOTE KEYLESS ENTRY SYSTEM

## 2. CHECK IPDM E/R INPUT VOLTAGE

1. Turn ignition switch OFF.
2. Disconnect IPDM E/R and horn relay.
3. Check continuity between IPDM E/R connector E122 terminal 45 and horn relay connector H-1 terminal 1.

**45 - 1 : Continuity should exist**

4. Check continuity between IPDM E/R connector E122 terminal 45 and ground.

**45 - Ground : Continuity should not exist**

OK or NG

OK >> Further inspection is necessary. Refer to [BL-76, "SYMP-TOM CHART"](#).

NG >> Repair or replace harness

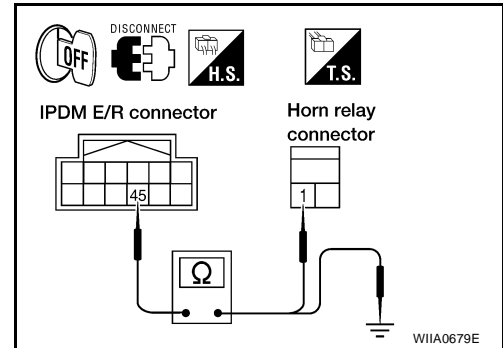

EIS004A4

## Check Hazard Function

### 1. CHECK HAZARD WARNING LAMP

Does hazard indicator flash with hazard switch?

Yes or No

Yes >> Hazard warning lamp circuit is OK.

No >> Check hazard indicator. Refer to [LT-76, "TURN SIGNAL AND HAZARD WARNING LAMPS"](#).

## Check Horn Function

EIS004A5

First, perform the "SELF-DIAG RESULTS" in "BCM" with CONSULT-II, then perform the trouble diagnosis of malfunction system indicated in "SELF-DIAG RESULTS" of "BCM".

### 1. CHECK HORN FUNCTION

Does horn sound with horn switch?

Yes or No

Yes >> Horn circuit is OK.

No >> Check horn circuit. Refer to [WW-36, "HORN"](#).

## Check Headlamp Function

EIS004A6

First, perform the "SELF-DIAG RESULTS" in "BCM" with CONSULT-II, then perform the trouble diagnosis of malfunction system indicated in "SELF-DIAG RESULTS" of "BCM".

### 1. CHECK HEADLAMP OPERATION

Does headlamp come on when turning lighting switch ON?

Yes or No

Yes >> Headlamp operation circuit is OK.

No >> Check headlamp circuit. Refer to [LT-5, "HEADLAMP \(FOR USA\)"](#).

## Check Front Room/Map Lamp Illumination Function

EIS004A7

### 1. CHECK MAP LAMP ILLUMINATION FUNCTION

When front room/map lamp switch is in DOOR position, open the front door LH or RH.

**Front room/map lamp should illuminate.**

OK or NG

OK >> Front room/map lamp illumination circuit is OK.

NG >> Check front room/map lamp illumination circuit. Refer to [LT-156, "ILLUMINATION"](#).

# DOOR

## DOOR Fitting Adjustment

PFP:80100

EIS004AV

### KING CAB

SEC. 800 • 820

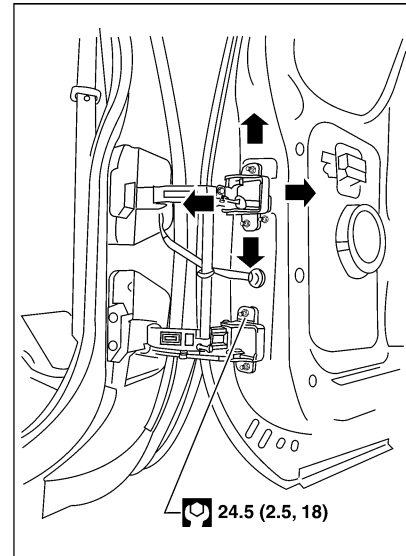
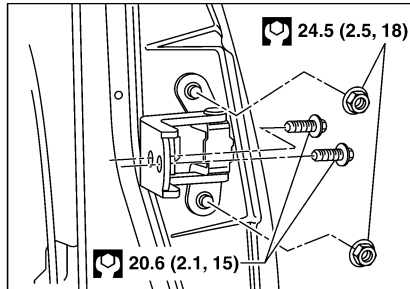
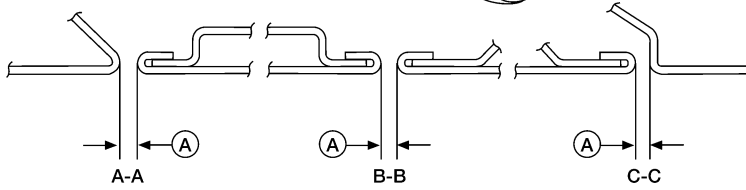
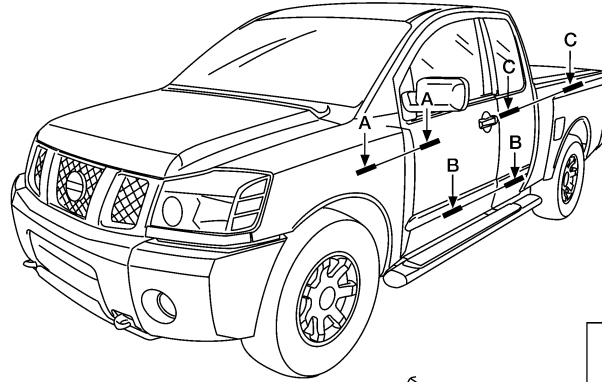

W1IA0905E

A.  $4.5 \pm 1.0$  mm ( $0.177 \pm 0.039$  in)

A  
B  
C  
D  
E  
F  
G  
H  
BL  
J  
K  
L  
M

# CAB AND REAR BODY

EIS004BN

## Body Mounting, Crew Cab

When removing, be sure to replace bolts and nuts (sealant applied bolts or self-lock nuts are used for all mounting).

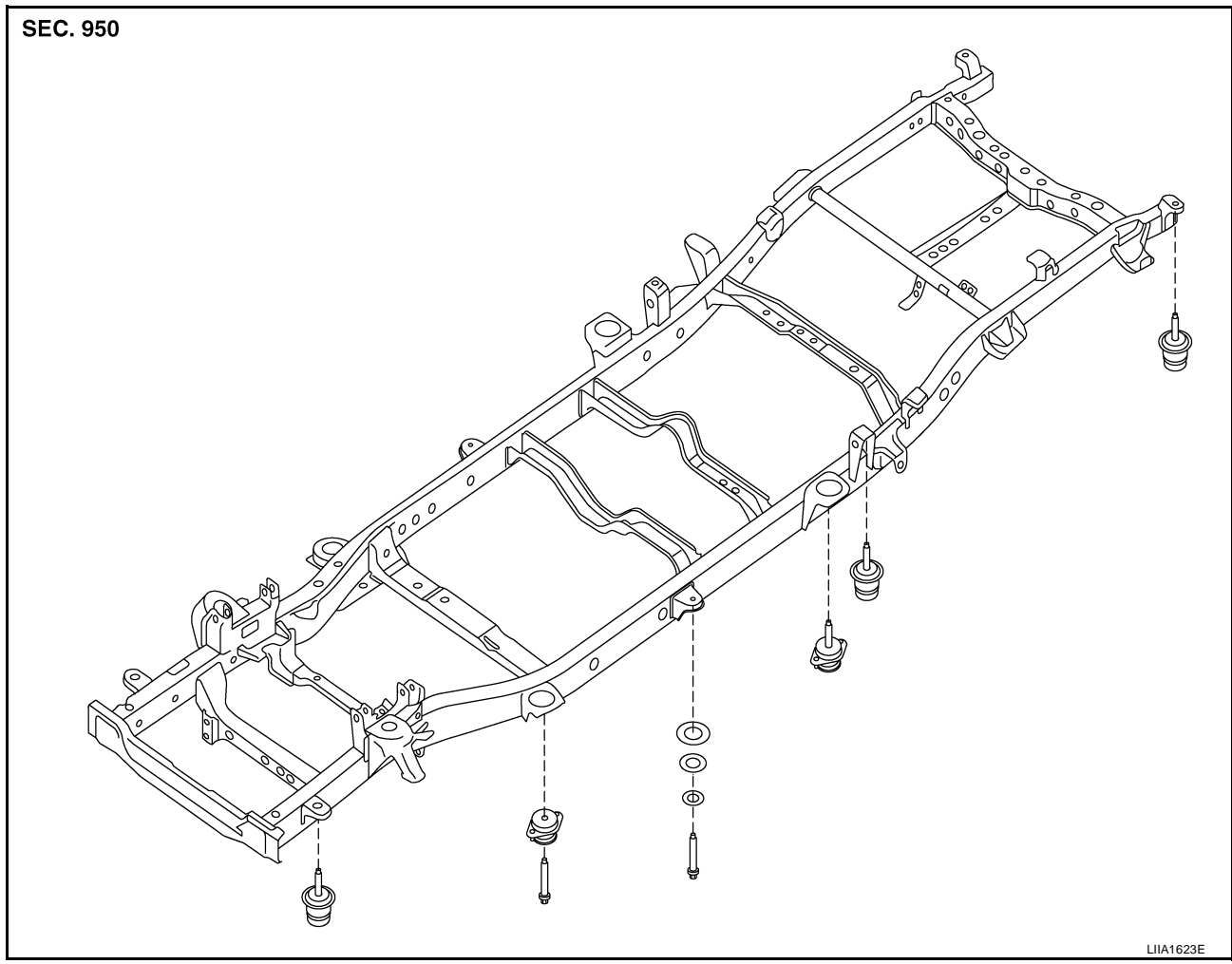

**Frame to Cab and bed bolts : 87.5 N-m (8.9 kg-m, 65 ft-lb)**

# BODY REPAIR

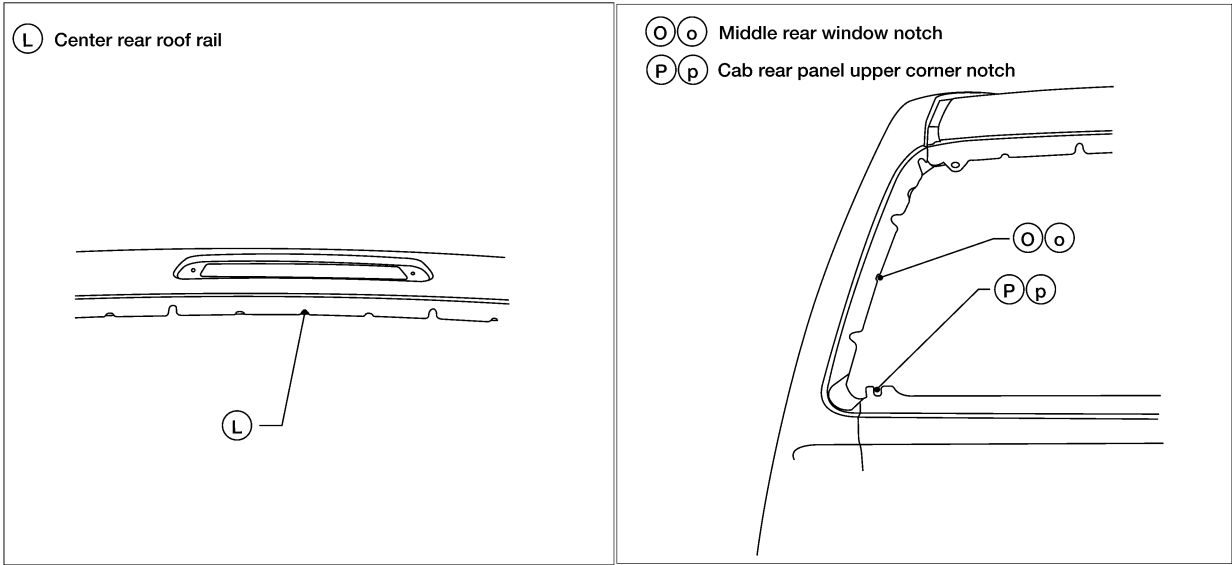

A  
B  
C  
D  
E  
F  
G  
H  
BL  
J  
K  
L  
M

LIA1322E

# BODY REPAIR

## Service Joint

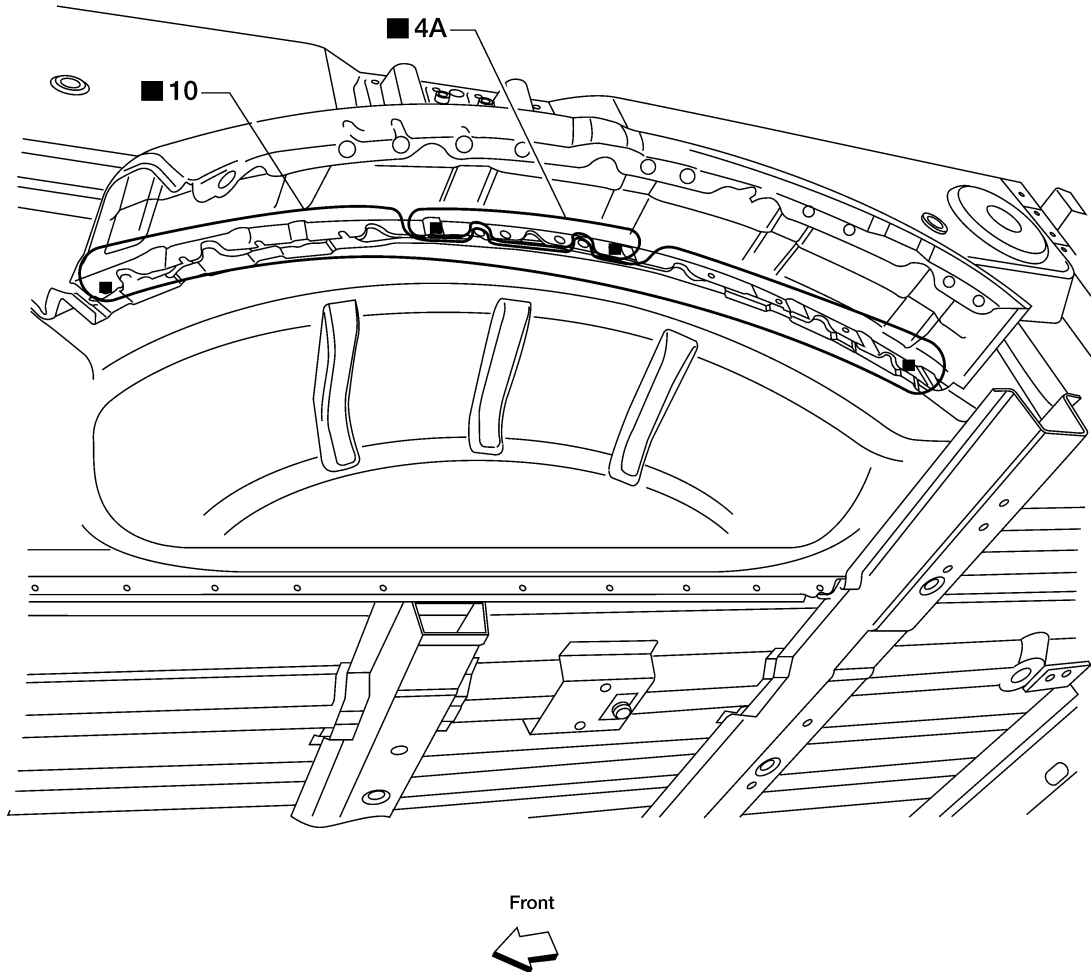

2-spot welds

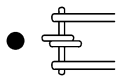

3-spot welds

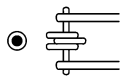

MIG Plug weld

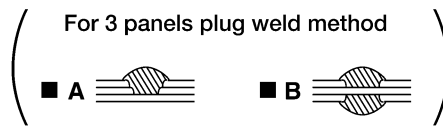
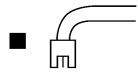

MIG seam weld/  
Point weld



LIA1218E

## FRONT DISC BRAKE

---

**CAUTION:**

**Only perform this procedure under safe road and traffic conditions. Use extreme caution.**

1. Drive the vehicle on a straight smooth road at 50 km/h (31 MPH).
2. Use medium brake pedal/foot effort to bring the vehicle to a complete stop from 50 km/h (31 MPH). Adjust brake pedal/foot pressure such that vehicle stopping time equals 3 to 5 seconds.
3. To cool brake system, drive the vehicle at 50 km/h (31 MPH) for 1 minute without stopping.
4. Repeat steps 1 to 3, 10 times or more to complete the burnishing procedure.

A

B

C

D

E

BR

G

H

I

J

K

L

M

**2. CONNECTOR INSPECTION**

1. Disconnect ABS actuator and electric unit (control unit) connector E125.
2. Check the terminals for deformation, disconnection, looseness or damage.

OK or NG

- OK >> GO TO 3.
- NG >> Repair or replace as necessary.

**3. CHECKING SOLENOID POWER AND GROUND**

1. Check voltage between ABS actuator and electric unit (control unit) harness connector E125 and body ground.

ABS actuator and electric unit (control unit) harness connector E125	Body ground	Measured value (Approx.)
32	—	12V

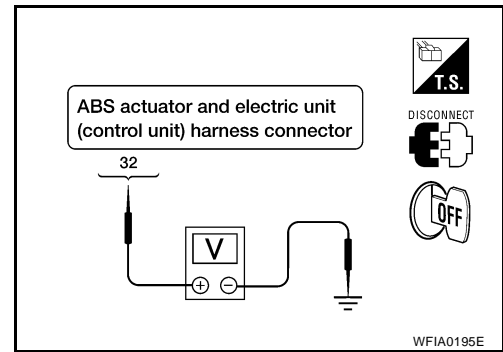

2. Check resistance between ABS actuator and electric unit (control unit) harness connector E125 and body ground.

ABS actuator and electric unit (control unit) harness connector E125	Body ground	Measured value Ω (Approx.)
16	—	0Ω
47	—	0Ω

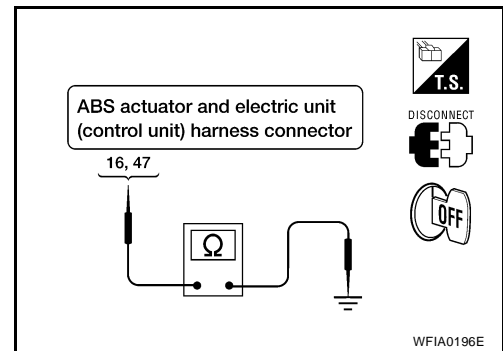

OK or NG

- OK >> Perform self-diagnosis again. If the same results appear, replace ABS actuator and electric unit (control unit). Refer to [BRC-40, "Removal and Installation"](#).
- NG >> Repair the circuit.

**Actuator Motor, Motor Relay, and Circuit Inspection**

EFS004PY

**INSPECTION PROCEDURE**

**1. CHECKING SELF-DIAGNOSIS RESULTS**

Check self-diagnosis results.

Self-diagnosis results
PUMP MOTOR
ACTUATOR RLY

Is the above displayed in the self-diagnosis display items?

- YES >> GO TO 2.
- NO >> Inspection End.

**2. CONNECTOR INSPECTION**

1. Disconnect ABS actuator and electric unit (control unit) connector E125.
2. Check the terminals for deformation, disconnection, looseness or damage.

OK or NG

- OK >> GO TO 3.
- NG >> Repair or replace as necessary.

# TROUBLE DIAGNOSIS

[ABLS/ABS]

Item (Unit)	Data monitor item selection			Remarks
	ECU INPUT SIGNALS	MAIN SIGNALS	SELECTION FROM MENU	
RR LH SENSOR (km/h, MPH)	×	×	×	Wheel speed calculated by rear LH wheel sensor signal is displayed.
BATTERY VOLT (V)	×	×	×	Voltage supplied to ABS actuator and electric unit (control unit) is displayed.
N POSI SIG	–	–	×	Shift position judged by PNP switch signal.
P POSI SIG	–	–	×	Shift position judged by PNP switch signal.
ACCEL POS SIG (%)	×	–	×	Throttle valve open/close status judged by CAN communication signal is displayed.
ENGINE SPEED (rpm)	×	×	×	Engine speed judged by CAN communication signal is displayed.
DECEL G-SEN (d/s)	×	×	×	Longitudinal acceleration detected by decel G-sensor is displayed.
STOP LAMP SW (ON/OFF)	×	×	×	Stop lamp switch (ON/OFF) status is displayed.
ABS WARN LAMP (ON/OFF)	–	×	×	ABS warning lamp (ON/OFF) status is displayed.
SLIP LAMP (ON/OFF)	–	×	×	SLIP indicator lamp (ON/OFF) status is displayed.
FR LH IN SOL (ON/OFF)	–	×	×	Front LH IN ABS solenoid (ON/OFF) status is displayed.
FR LH OUT SOL (ON/OFF)	–	×	×	Front LH OUT ABS solenoid (ON/OFF) status is displayed.
RR RH IN SOL (ON/OFF)	–	×	×	Rear RH IN ABS solenoid (ON/OFF) status is displayed.
RR RH OUT SOL (ON/OFF)	–	×	×	Rear RH OUT ABS solenoid (ON/OFF) status is displayed.
FR RH IN SOL (ON/OFF)	–	×	×	Front RH IN ABS solenoid (ON/OFF) status is displayed.
FR RH OUT SOL (ON/OFF)	–	×	×	Front RH OUT ABS solenoid (ON/OFF) status is displayed.
RR LH IN SOL (ON/OFF)	–	×	×	Rear LH IN ABS solenoid (ON/OFF) status is displayed.
RR LH OUT SOL (ON/OFF)	–	×	×	Rear LH OUT ABS solenoid (ON/OFF) status is displayed.
MOTOR RELAY (ON/OFF)	–	×	×	ABS motor relay signal (ON/OFF) status is displayed.
ACTUATOR RLY (ON/OFF)	–	×	×	ABS actuator relay signal (ON/OFF) status is displayed.
CV1 (ON/OFF)	–	–	×	Front side switch-over solenoid valve (cut valve) (ON/OFF) status is displayed.
CV2 (ON/OFF)	–	–	×	Rear side switch-over solenoid valve (cut-valve) (ON/OFF) status is displayed.
SV1 (ON/OFF)	–	–	×	Front side switch-over solenoid valve (suction valve) (ON/OFF) status is displayed.

A

B

C

D

E

BRC

G

H

I

J

K

L

M

# TROUBLE DIAGNOSIS

[VDC/TCS/ABS]

## BRC-VDC-04

▬ : DATA LINE

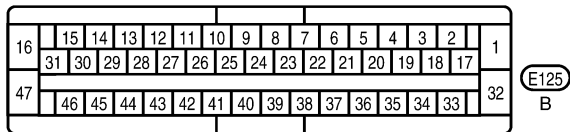
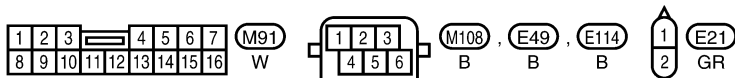
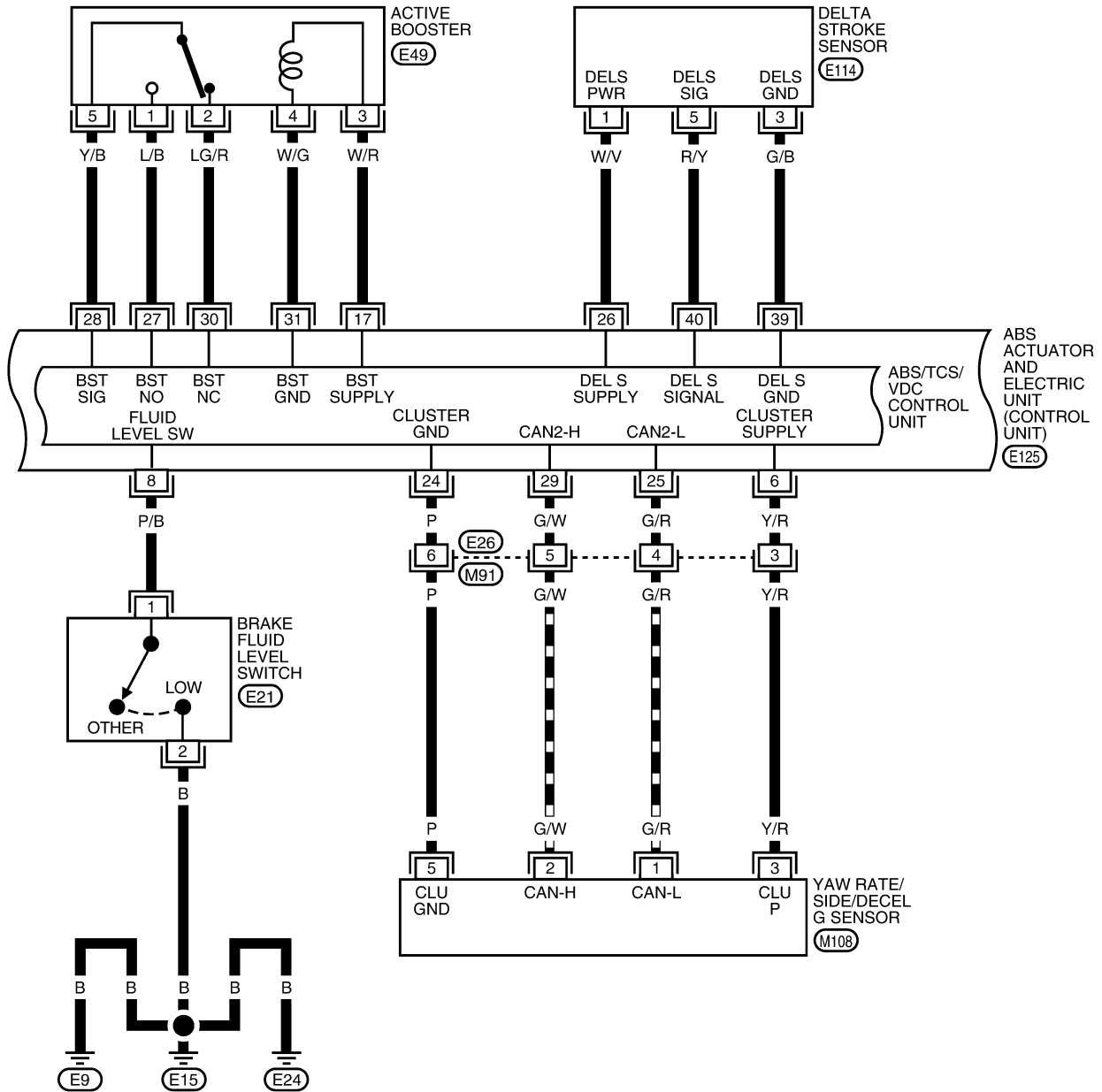

WFWA0329E

**TROUBLE DIAGNOSES FOR SYMPTOMS**

PFP:99999

**ABS Works Frequently**

EFS005FS

**1. CHECK WARNING LAMP ACTIVATION**

Make sure warning lamp remains off while driving.

OK or NG

OK >> GO TO 2.

NG >> Carry out self-diagnosis. Refer to [BRC-114, "SELF-DIAGNOSIS"](#) .

**2. CHECK WHEEL SENSORS**

Check the following.

- Wheel sensor mounting for looseness
- Wheel sensors for physical damage
- Wheel sensor connectors for terminal damage or loose connections
- Sensor rotor and mount for physical damage (rear only)

OK or NG

OK >> GO TO 3.

NG >> Repair or replace as necessary.

**3. CHECK FRONT AND REAR AXLES**

Check front and rear axles for excessive looseness. Refer to [FAX-5, "WHEEL BEARING INSPECTION"](#) or [RAX-5, "WHEEL BEARING INSPECTION"](#) .

OK or NG

OK >> GO TO 4.

NG >> Repair as necessary.

**4. CHECK BRAKE FLUID PRESSURE**

Check brake fluid pressure distribution.

Refer to [BRC-108, "Basic Inspection"](#) .

Is brake fluid pressure distribution normal?

YES >> Inspection End.

NO >> Perform Basic Inspection. Refer to [BRC-108, "Basic Inspection"](#) .

A

B

C

D

E

BRC

G

H

I

J

K

L

M

# SERVICE DATA AND SPECIFICATIONS (SDS)

---

# WARNING LAMPS

EKS00D7C

## Oil Pressure Warning Lamp Stays Off (Ignition Switch ON)

### 1. CHECK OIL PRESSURE SENSOR SIGNAL

1. Turn ignition switch ON.
2. Check voltage between combination meter harness connector M24 terminal 20 and ground.

Terminals		Condition	Voltage (V)
(+)	(-)		
Connector	Terminal		
M24	20	When ignition switch is in ON position. (Engine stopped)	Yes
		Engine running. (Idle speed)	Yes

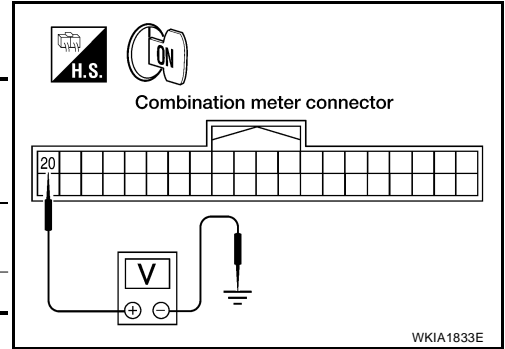

OK or NG

- OK >> GO TO 2.
- NG >> GO TO 3.

### 2. CHECK OIL PRESSURE SENSOR GROUND CIRCUIT

1. Turn ignition switch OFF.
2. Disconnect combination meter connector M24 and oil pressure sensor connector F4.
3. Check continuity between combination meter harness connector M24 terminal 16 and oil pressure sensor harness connector F4 terminal 3.

**Continuity should exist.**

OK or NG

- OK >> Replace the combination meter. Refer to [IP-13, "COMBINATION METER"](#).
- NG >> Repair harness or connector.

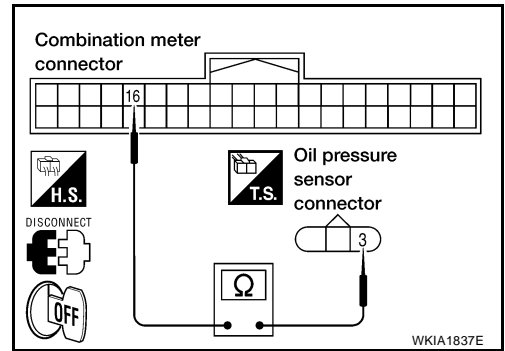

### 3. CHECK OIL PRESSURE SENSOR REFERENCE VOLTAGE

1. Turn ignition switch OFF.
2. Disconnect oil pressure sensor connector F4.
3. Turn ignition switch ON.
4. Check voltage between combination meter harness connector M24 terminal 22 and ground.

**Voltage : Approx. 5V**

OK or NG

- OK >> GO TO 4.
- NG >> Replace the combination meter. Refer to [IP-13, "COMBINATION METER"](#).

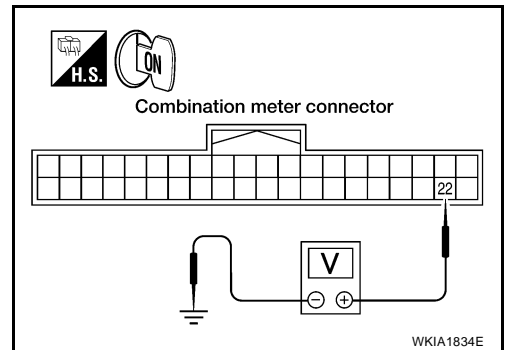

Component Inspection .....	352	<b>VALVE .....</b>	<b>401</b>
Removal and Installation .....	352	Component Description .....	401
<b>DTC P0340 CMP SENSOR (PHASE) .....</b>	<b>353</b>	CONSULT-II Reference Value in Data Monitor Mode .....	401
Component Description .....	353	On Board Diagnosis Logic .....	401
On Board Diagnosis Logic .....	353	DTC Confirmation Procedure .....	402
DTC Confirmation Procedure .....	353	Wiring Diagram .....	403
Wiring Diagram .....	355	Diagnostic Procedure .....	404
Diagnostic Procedure .....	356	Component Inspection .....	406
Component Inspection .....	359	<b>DTC P0451 EVAP CONTROL SYSTEM PRESSURE</b>	
Removal and Installation .....	359	<b>SENSOR .....</b>	<b>408</b>
<b>DTC P0420, P0430 THREE WAY CATALYST FUNCTION .....</b>	<b>360</b>	Component Description .....	408
On Board Diagnosis Logic .....	360	CONSULT-II Reference Value in Data Monitor Mode .....	408
DTC Confirmation Procedure .....	360	On Board Diagnosis Logic .....	408
Overall Function Check .....	361	DTC Confirmation Procedure .....	409
Diagnostic Procedure .....	362	Diagnostic Procedure .....	409
<b>DTC P0441 EVAP CONTROL SYSTEM .....</b>	<b>366</b>	Component Inspection .....	410
System Description .....	366	<b>DTC P0452 EVAP CONTROL SYSTEM PRESSURE</b>	
On Board Diagnosis Logic .....	366	<b>SENSOR .....</b>	<b>411</b>
DTC Confirmation Procedure .....	366	Component Description .....	411
Overall Function Check .....	367	CONSULT-II Reference Value in Data Monitor Mode .....	411
Diagnostic Procedure .....	368	On Board Diagnosis Logic .....	411
<b>DTC P0442 EVAP CONTROL SYSTEM .....</b>	<b>371</b>	DTC Confirmation Procedure .....	412
On Board Diagnosis Logic .....	371	Wiring Diagram .....	413
DTC Confirmation Procedure .....	372	Diagnostic Procedure .....	414
Diagnostic Procedure .....	373	Component Inspection .....	416
<b>DTC P0443 EVAP CANISTER PURGE VOLUME CONTROL SOLENOID VALVE .....</b>	<b>379</b>	<b>DTC P0453 EVAP CONTROL SYSTEM PRESSURE</b>	
Description .....	379	<b>SENSOR .....</b>	<b>417</b>
CONSULT-II Reference Value in Data Monitor Mode .....	379	Component Description .....	417
On Board Diagnosis Logic .....	380	CONSULT-II Reference Value in Data Monitor Mode .....	417
DTC Confirmation Procedure .....	380	On Board Diagnosis Logic .....	417
Wiring Diagram .....	381	DTC Confirmation Procedure .....	418
Diagnostic Procedure .....	383	Wiring Diagram .....	419
Component Inspection .....	386	Diagnostic Procedure .....	420
Removal and Installation .....	386	Component Inspection .....	424
<b>DTC P0444, P0445 EVAP CANISTER PURGE VOLUME CONTROL SOLENOID VALVE .....</b>	<b>387</b>	<b>DTC P0455 EVAP CONTROL SYSTEM .....</b>	<b>425</b>
Description .....	387	On Board Diagnosis Logic .....	425
CONSULT-II Reference Value in Data Monitor Mode .....	387	DTC Confirmation Procedure .....	426
On Board Diagnosis Logic .....	388	Diagnostic Procedure .....	427
DTC Confirmation Procedure .....	388	<b>DTC P0456 EVAP CONTROL SYSTEM .....</b>	<b>433</b>
Wiring Diagram .....	389	On Board Diagnosis Logic .....	433
Diagnostic Procedure .....	391	DTC Confirmation Procedure .....	434
Component Inspection .....	392	Overall Function Check .....	435
Removal and Installation .....	393	Diagnostic Procedure .....	436
<b>DTC P0447 EVAP CANISTER VENT CONTROL VALVE .....</b>	<b>394</b>	<b>DTC P0460 FUEL LEVEL SENSOR .....</b>	<b>442</b>
Component Description .....	394	Component Description .....	442
CONSULT-II Reference Value in Data Monitor Mode .....	394	On Board Diagnosis Logic .....	442
On Board Diagnosis Logic .....	394	DTC Confirmation Procedure .....	442
DTC Confirmation Procedure .....	395	Diagnostic Procedure .....	443
Wiring Diagram .....	396	Removal and Installation .....	443
Diagnostic Procedure .....	397	<b>DTC P0461 FUEL LEVEL SENSOR .....</b>	<b>444</b>
Component Inspection .....	399	Component Description .....	444
<b>DTC P0448 EVAP CANISTER VENT CONTROL</b>		On Board Diagnosis Logic .....	444
		Overall Function Check .....	444
		Diagnostic Procedure .....	445
		Removal and Installation .....	445

# ON BOARD REFUELING VAPOR RECOVERY (ORVR)

**SYMPTOM: CANNOT REFUEL/FUEL ODOR FROM THE FUEL FILLER OPENING IS STRONG WHILE REFUELING.**

## 1. CHECK EVAP CANISTER

1. Remove EVAP canister with EVAP canister vent control valve and EVAP control system pressure sensor attached.
2. Weigh the EVAP canister with EVAP canister vent control valve and EVAP control system pressure sensor attached.

**The weight should be less than 2.5 kg (5.5 lb).**

OK or NG

OK >> GO TO 2.

NG >> GO TO 3.

## 2. CHECK IF EVAP CANISTER SATURATED WITH WATER

Does water drain from the EVAP canister?

Yes or No

Yes >> GO TO 3.

No >> GO TO 5.

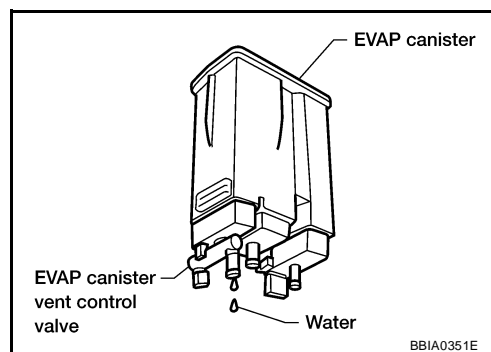

## 3. REPLACE EVAP CANISTER

Replace EVAP canister with a new one.

>> GO TO 4.

## 4. DETECT MALFUNCTIONING PART

Check the EVAP hose between EVAP canister and vehicle frame for clogging or poor connection.

>> Repair or replace EVAP hose.

## 5. CHECK VENT HOSES AND VENT TUBES

Check hoses and tubes between EVAP canister and refueling EVAP vapor cut valve for clogging, kink, looseness and improper connection.

OK or NG

OK >> GO TO 6.

NG >> Repair or replace hoses and tubes.

## 6. CHECK FILLER NECK TUBE

Check recirculation line for clogging, dents and cracks.

OK or NG

OK >> GO TO 7.

NG >> Replace filler neck tube.

# BASIC SERVICE PROCEDURE

---

## 6. PERFORM ETHANOL MIXTURE RATIO ADAPTATION

---

Perform [EC-84, "Ethanol Mixture Ratio Adaptation \(Flexible Fuel Vehicle\)"](#) .

>> GO TO 7.

---

## 7. PERFORM IDLE AIR VOLUME LEARNING

---

Refer to [EC-85, "Idle Air Volume Learning"](#) .

**Is Idle Air Volume Learning carried out successfully?**

Yes or No

Yes >> GO TO 8.

No >> 1. Follow the instruction of Idle Air Volume Learning.  
2. GO TO 4.

---

## 8. CHECK TARGET IDLE SPEED AGAIN

---

**With CONSULT-II**

1. Start engine and warm it up to normal operating temperature.
2. Read idle speed in "DATA MONITOR" mode with CONSULT-II.  
Refer to [EC-81, "IDLE SPEED"](#) .

**650 ± 50 rpm (in P or N position)**

**Without CONSULT-II**

1. Start engine and warm it up to normal operating temperature.
2. Check idle speed.  
Refer to [EC-81, "IDLE SPEED"](#) .

**650 ± 50 rpm (in P or N position)**

OK or NG

OK >> GO TO 11.

NG >> GO TO 9.

---

## 9. DETECT MALFUNCTIONING PART

---

Check the following.

- Check camshaft position sensor (PHASE) and circuit. Refer to [EC-353, "DTC P0340 CMP SENSOR \(PHASE\)"](#) .
- Check crankshaft position sensor (POS) and circuit. Refer to [EC-346, "DTC P0335 CKP SENSOR \(POS\)"](#) .

OK or NG

OK >> GO TO 10.

NG >> 1. Repair or replace.  
2. GO TO 4.

---

## 10. CHECK ECM FUNCTION

---

1. Substitute another known-good ECM to check ECM function. (ECM may be the cause of an incident, but this is a rare case.)
2. Perform initialization of NVIS (NATS) system and registration of all NVIS (NATS) ignition key IDs. Refer to [BL-141, "ECM Re-communicating Function"](#) .

>> GO TO 4.

# TROUBLE DIAGNOSIS

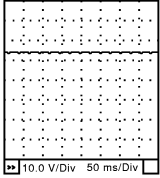
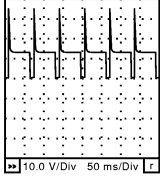
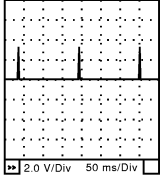
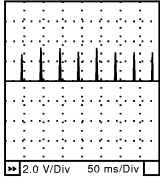
TER-MINAL NO.	WIRE COLOR	ITEM	CONDITION	DATA (DC Voltage)
45	L/Y	EVAP canister purge volume control solenoid valve	<b>[Engine is running]</b> <ul style="list-style-type: none"> <li>● Idle speed</li> <li>● Accelerator pedal: Not depressed even slightly, after engine starting</li> </ul>	<b>BATTERY VOLTAGE (11 - 14V)★</b>  <small>SEC990C</small>
			<b>[Engine is running]</b> <ul style="list-style-type: none"> <li>● Engine speed: About 2,000 rpm (More than 100 seconds after starting engine)</li> </ul>	<b>BATTERY VOLTAGE (11 - 14V)★</b>  <small>SEC991C</small>
46 60 61 62	L/R GR/R O/W Y/R	Ignition signal No. 7 Ignition signal No. 5 Ignition signal No. 3 Ignition signal No. 1	<b>[Engine is running]</b> <ul style="list-style-type: none"> <li>● Warm-up condition</li> <li>● Idle speed</li> </ul> <b>NOTE:</b> The pulse cycle changes depending on rpm at idle	<b>0 - 0.3V★</b>  <small>SEC986C</small>
			<b>[Engine is running]</b> <ul style="list-style-type: none"> <li>● Warm-up condition</li> <li>● Engine speed: 2,500 rpm</li> </ul>	<b>0.1 - 0.6V★</b>  <small>SEC987C</small>
47	Y	Sensor power supply (Throttle position sensor)	<b>[Ignition switch: ON]</b>	Approximately 5V
48	SB	Sensor power supply (EVAP control system pressure sensor)	<b>[Ignition switch: ON]</b>	Approximately 5V
49	R/Y	Sensor power supply (Refrigerant pressure sensor)	<b>[Ignition switch: ON]</b>	Approximately 5V
50	B	Throttle position sensor 1	<b>[Ignition switch: ON]</b> <ul style="list-style-type: none"> <li>● Engine: Stopped</li> <li>● Selector lever: D</li> <li>● Accelerator pedal: Fully released</li> </ul>	More than 0.36V
			<b>[Ignition switch: ON]</b> <ul style="list-style-type: none"> <li>● Engine: Stopped</li> <li>● Selector lever: D</li> <li>● Accelerator pedal: Fully depressed</li> </ul>	Less than 4.75V

A  
EC  
C  
D  
E  
F  
G  
H  
I  
J  
K  
L  
M

# POWER SUPPLY AND GROUND CIRCUIT

Specification data are reference values and are measured between each terminal and ground.

## CAUTION:

**Do not use ECM ground terminals when measuring input/output voltage. Doing so may result in damage to the ECM's transistor. Use a ground other than ECM terminals, such as the ground.**

TER-MINAL NO.	WIRE COLOR	ITEM	CONDITION	DATA (DC Voltage)
1	B	ECM ground	<b>[Engine is running]</b> ● Idle speed	Body ground
109	L/W	Ignition switch	<b>[Ignition switch: OFF]</b>	0V
			<b>[Ignition switch: ON]</b>	BATTERY VOLTAGE (11 - 14V)
111	W/B	ECM relay (Self shut-off)	<b>[Engine is running]</b> <b>[Ignition switch: OFF]</b> ● For a few seconds after turning ignition switch OFF	0 - 1.5V
			<b>[Ignition switch: OFF]</b> ● More than a few seconds after turning ignition switch OFF	BATTERY VOLTAGE (11 - 14V)
115 116	B B/W	ECM ground	<b>[Engine is running]</b> ● Idle speed	Body ground
119 120	BR BR	Power supply for ECM	<b>[Ignition switch: ON]</b>	BATTERY VOLTAGE (11 - 14V)

## Diagnostic Procedure

UBS00NB4

### 1. INSPECTION START

Start engine.

**Is engine running?**

Yes or No

Yes >> GO TO 8.

No >> GO TO 2.

### 2. CHECK ECM POWER SUPPLY CIRCUIT-I

- Turn ignition switch OFF and then ON.
- Check voltage between ECM terminal 109 and ground with CONSULT-II or tester.

**Voltage: Battery voltage**

OK or NG

OK >> GO TO 4.

NG >> GO TO 3.

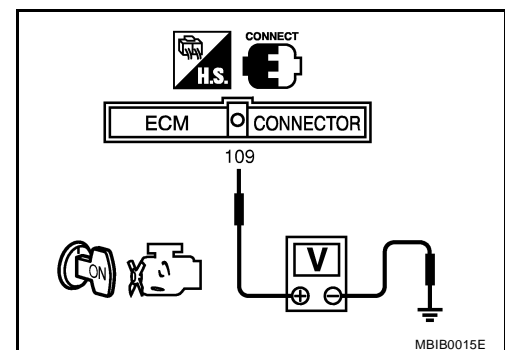

### 3. DETECT MALFUNCTIONING PART

Check the following.

- 10A fuse
- Harness for open or short between ECM and fuse

>> Repair harness or connectors.

# DTC P0102, P0103 MAF SENSOR

Specification data are reference values and are measured between each terminal and ground.

**CAUTION:**

**Do not use ECM ground terminals when measuring input/output voltage. Doing so may result in damage to the ECM's transistor. Use a ground other than ECM terminals, such as the ground.**

TER-MINAL NO.	WIRE COLOR	ITEM	CONDITION	DATA (DC Voltage)
51	W	Mass air flow sensor	[Engine is running] ● Warm-up condition ● Idle speed	1.0 - 1.3V
			[Engine is running] ● Warm-up condition ● Engine speed: 2,500 rpm.	1.7 - 2.1V
67	B	Sensor ground	[Engine is running] ● Warm-up condition ● Idle speed	Approximately 0V
111	W/B	ECM relay (Self shut-off)	[Engine is running] [Ignition switch: OFF] ● For a few seconds after turning ignition switch OFF	0 - 1.5V
			[Ignition switch: OFF] ● More than a few seconds after turning ignition switch OFF	BATTERY VOLTAGE (11 - 14V)
119 120	BR BR	Power supply for ECM	[Ignition switch: ON]	BATTERY VOLTAGE (11 - 14V)

## Diagnostic Procedure

UBS00NC9

### 1. INSPECTION START

Which malfunction (P0102 or P0103) is duplicated?

P0102 or P0103

P0102 >> GO TO 2.

P0103 >> GO TO 3.

### 2. CHECK INTAKE SYSTEM

Check the following for connection.

- Air duct
- Vacuum hoses
- Intake air passage between air duct to intake manifold

OK or NG

OK >> GO TO 3.

NG >> Reconnect the parts.

# DTC P0130, P0150 A/F SENSOR 1

## 2. CHECK AIR FUEL RATIO (A/F) SENSOR 1 POWER SUPPLY CIRCUIT

1. Disconnect A/F sensor 1 harness connector.

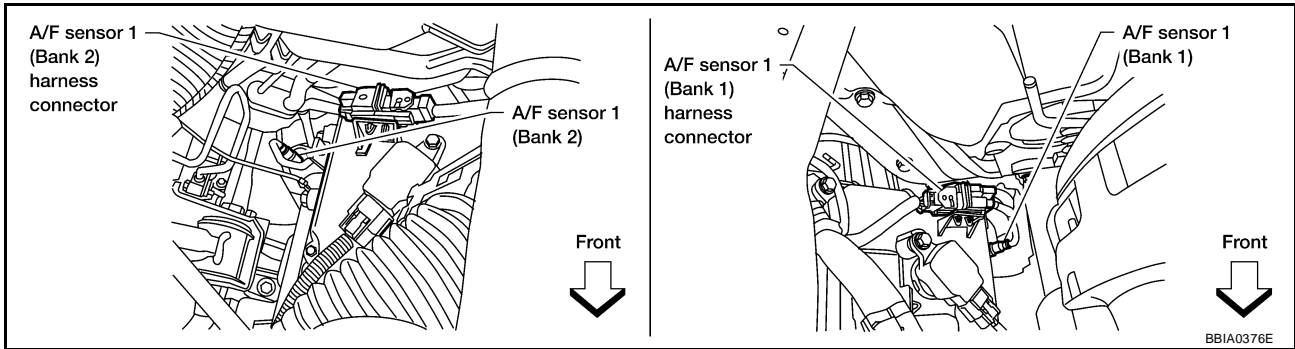

2. Turn ignition switch ON.
3. Check voltage between A/F sensor 1 terminal 3 and ground with CONSULT-II or tester.

**Voltage: Battery voltage**

OK or NG

- OK >> GO TO 4.
- NG >> GO TO 3.

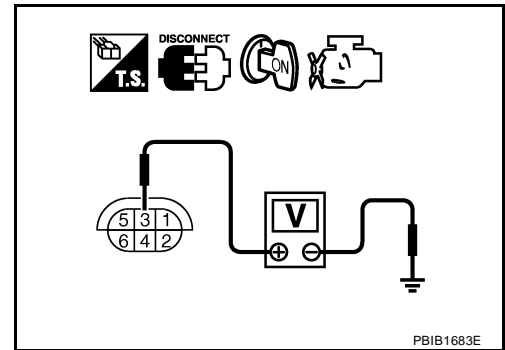

## 3. DETECT MALFUNCTIONING PART

Check the following.

- Harness connectors E5, F14
- IPDM E/R harness connector E119
- 10A fuse
- Harness for open or short between A/F sensor 1 and fuse

>> Repair or replace harness or connectors.

## DTC P0137, P0157 HO2S2

Specification data are reference values and are measured between each terminal and ground.

**CAUTION:**

**Do not use ECM ground terminals when measuring input/output voltage. Doing so may result in damage to the ECM's transistor. Use a ground other than ECM terminals, such as the ground.**

TER-MINAL NO.	WIRE COLOR	ITEM	CONDITION	DATA (DC Voltage)
6	GR	Heated oxygen sensor 2 heater (bank 1)	<b>[Engine is running]</b> <ul style="list-style-type: none"> <li>● Engine speed: Below 3,600 rpm after the following conditions are met.                             <ul style="list-style-type: none"> <li>– Engine: After warming up</li> <li>– Keeping the engine speed between 3,500 and 4,000 rpm for 1 minute and at idle for 1 minute under no load</li> </ul> </li> </ul>	0 - 1.0V
			<b>[Ignition switch: ON]</b> <ul style="list-style-type: none"> <li>● Engine: Stopped</li> </ul> <b>[Engine is running]</b> <ul style="list-style-type: none"> <li>● Engine speed: Above 3,600 rpm.</li> </ul>	BATTERY VOLTAGE (11 - 14V)
55	R	Heated oxygen sensor 2 (bank 1)	<b>[Engine is running]</b> <ul style="list-style-type: none"> <li>● Revving engine from idle to 3,000 rpm quickly after the following conditions are met.                             <ul style="list-style-type: none"> <li>– Engine: After warming up</li> <li>– Keeping the engine speed between 3,500 and 4,000 rpm for 1 minute and at idle for 1 minute under no load</li> </ul> </li> </ul>	0 - Approximately 1.0V
78	B/W	Sensor ground (Heated oxygen sensor 2)	<b>[Engine is running]</b> <ul style="list-style-type: none"> <li>● Warm-up condition</li> <li>● Idle speed</li> </ul>	Approximately 0V

A  
EC  
C  
D  
E  
F  
G  
H  
I  
J  
K  
L  
M

# DTC P0171, P0174 FUEL INJECTION SYSTEM FUNCTION

## Diagnostic Procedure

UBS00NEO

### 1. CHECK EXHAUST GAS LEAK

1. Start engine and run it at idle.
2. Listen for an exhaust gas leak before three way catalyst (manifold).

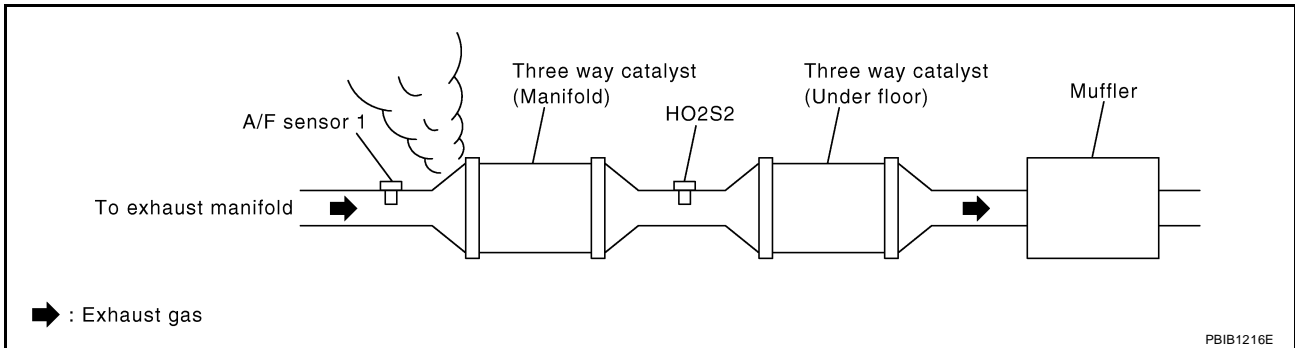

#### OK or NG

- OK >> GO TO 2.
- NG >> Repair or replace.

### 2. CHECK FOR INTAKE AIR LEAK

1. Listen for an intake air leak after the mass air flow sensor.
2. Check PCV hose connection.

#### OK or NG

- OK >> GO TO 3.
- NG >> Repair or replace.

## 7. CHECK SPARK PLUG

Check the initial spark plug for fouling, etc.

OK or NG

- OK >> Replace spark plug(s) with standard type one(s). For spark plug type, refer to [EM-29, "SPARK PLUG \(PLATINUM-TIPPED TYPE\)"](#).
- NG >> 1. Repair or clean spark plug.  
2. GO TO 8.

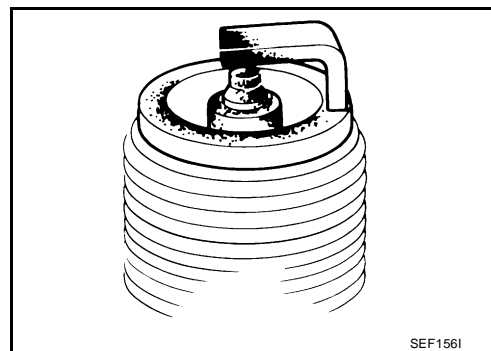

## 8. CHECK FUNCTION OF IGNITION COIL-III

1. Reconnect the initial spark plugs.
2. Crank engine for about 3 seconds, and recheck whether spark is generated between the spark plug and the grounded portion.

**Spark should be generated.**

OK or NG

- OK >> **INSPECTION END**
- NG >> Replace spark plug(s) with standard type one(s). For spark plug type, refer to [EM-29, "SPARK PLUG \(PLATINUM-TIPPED TYPE\)"](#).

## 9. CHECK COMPRESSION PRESSURE

Check compression pressure. Refer to [EM-63, "CHECKING COMPRESSION PRESSURE"](#).

OK or NG

- OK >> GO TO 10.
- NG >> Check pistons, piston rings, valves, valve seats and cylinder head gaskets.

## 10. CHECK FUEL PRESSURE

1. Install all removed parts.
2. Release fuel pressure to zero. Refer to [EC-87, "FUEL PRESSURE RELEASE"](#).
3. Install fuel pressure gauge and check fuel pressure. Refer to [EC-88, "FUEL PRESSURE CHECK"](#).

**At idle: Approx. 350 kPa (3.57 kg/cm<sup>2</sup> , 51 psi)**

OK or NG

- OK >> GO TO 12.
- NG >> GO TO 11.

## 11. DETECT MALFUNCTIONING PART

Check the following.

- Fuel pump and circuit (Refer to [EC-598, "FUEL PUMP"](#) .)
- **<Flexible Fuel Vehicle>**  
FPCM and circuit (Refer to [EC-489, "DTC P1220 FUEL PUMP CONTROL MODULE \(FPCM\)"](#) .)
- Fuel pressure regulator (Refer to [EC-88, "FUEL PRESSURE CHECK"](#) .)
- Fuel lines
- Fuel filter for clogging

>> Repair or replace.

# DTC P0442 EVAP CONTROL SYSTEM

## 5. INSTALL THE PRESSURE PUMP

To locate the EVAP leak, install EVAP service port adapter and pressure pump to EVAP service port securely.

**NOTE:**

**Improper installation of the EVAP service port adapter to the EVAP service port may cause leaking.**

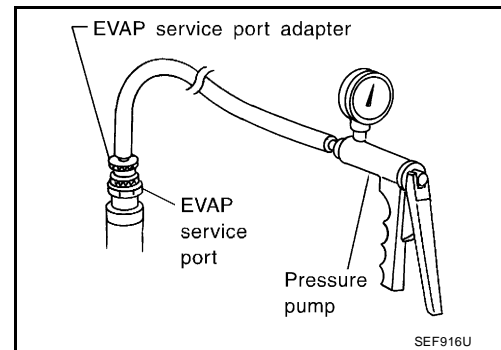
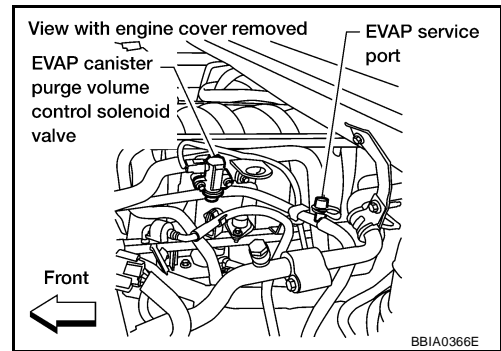

With CONSULT-II>>GO TO 6.  
Without CONSULT-II>>GO TO 7.

## 6. CHECK FOR EVAP LEAK

**With CONSULT-II**

1. Turn ignition switch ON.
2. Select "EVAP SYSTEM CLOSE" of "WORK SUPPORT" mode with CONSULT-II.
3. Touch "START" and apply pressure into the EVAP line until the pressure indicator reaches the middle of the bar graph.

**CAUTION:**

- Never use compressed air or a high pressure pump.
- Do not exceed 4.12 kPa (0.042 kg/cm<sup>2</sup> , 0.6 psi) of pressure in the system.

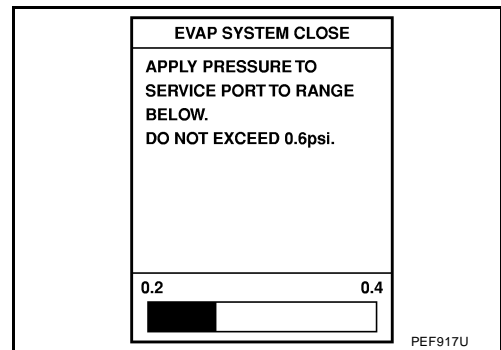

4. Using EVAP leak detector, locate the EVAP leak. For the leak detector, refer to the instruction manual for more details.  
Refer to [EC-33, "EVAPORATIVE EMISSION LINE DRAWING"](#) .

**OK or NG**

- OK >> GO TO 8.  
NG >> Repair or replace.

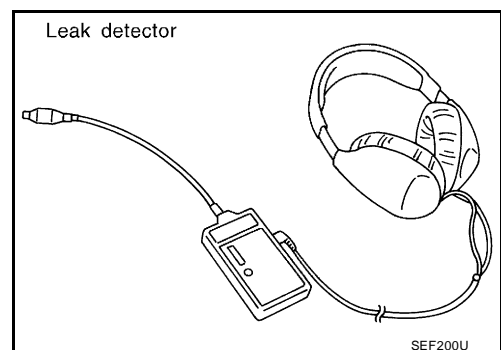

# DTC P0452 EVAP CONTROL SYSTEM PRESSURE SENSOR

## DTC P0452 EVAP CONTROL SYSTEM PRESSURE SENSOR

PF2:25085

### Component Description

UBS00NHG

The EVAP control system pressure sensor detects pressure in the purge line. The sensor output voltage to the ECM increases as pressure increases.

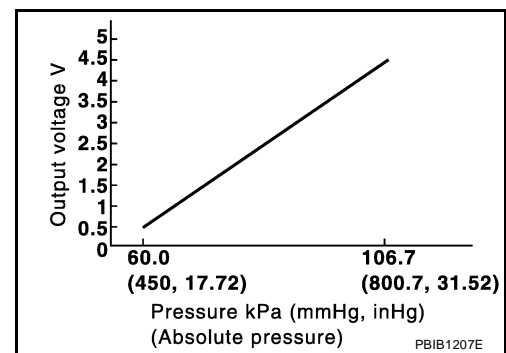
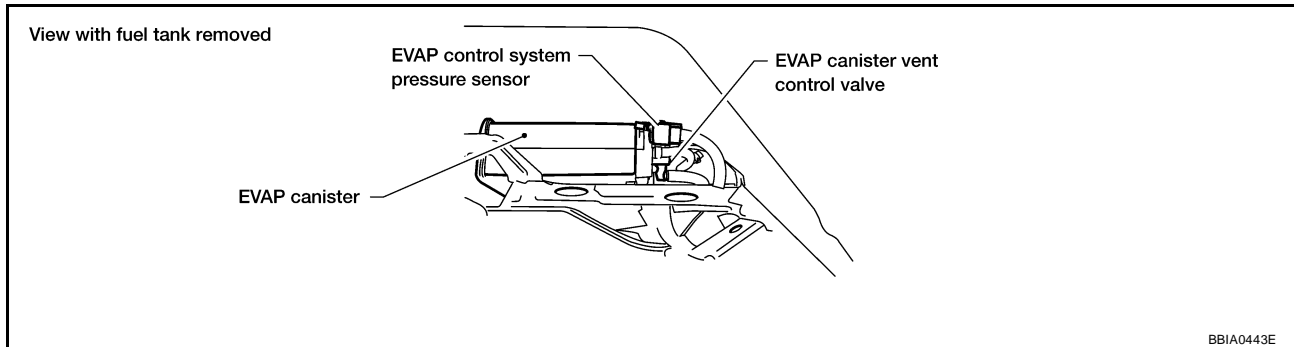

### CONSULT-II Reference Value in Data Monitor Mode

UBS00NHH

Specification data are reference values.

MONITOR ITEM	CONDITION	SPECIFICATION
EVAP SYS PRES	● Ignition switch: ON	Approx. 1.8 - 4.8V

### On Board Diagnosis Logic

UBS00NHI

#### NOTE:

If DTC P0452 is displayed with DTC P0643, first perform the trouble diagnosis for DTC P0643. Refer to [EC-466. "DTC P0643 SENSOR POWER SUPPLY"](#).

DTC No.	Trouble diagnosis name	DTC detecting condition	Possible cause
P0452 0452	EVAP control system pressure sensor low input	An excessively low voltage from the sensor is sent to ECM.	<ul style="list-style-type: none"> <li>● Harness or connectors (The sensor circuit is open or shorted.)</li> <li>● EVAP control system pressure sensor</li> </ul>

# DTC P0500 VSS

PF3:32702

## DTC P0500 VSS

### Description

UBS00NIG

#### NOTE:

- If DTC P0500 is displayed with DTC U1000 or U1001, first perform the trouble diagnosis for DTC U1000, U1001. Refer to [EC-157, "DTC U1000, U1001 CAN COMMUNICATION LINE"](#).
- If DTC P0500 is displayed with DTC U1010, first perform the trouble diagnosis for DTC U1010. Refer to [EC-160, "DTC U1010 CAN COMMUNICATION"](#).

The vehicle speed signal is sent to the combination meter from the "ABS actuator and electric unit (control unit)" by CAN communication line. The combination meter then sends a signal to the ECM by CAN communication line.

### On Board Diagnosis Logic

UBS00NIH

DTC No.	Trouble diagnosis name	DTC detecting condition	Possible cause
P0500 0500	Vehicle speed sensor	The almost 0 km/h (0 MPH) signal from vehicle speed sensor is sent to ECM even when vehicle is being driven.	<ul style="list-style-type: none"> <li>● Harness or connectors (The CAN communication line is open or shorted)</li> <li>● Harness or connectors (The vehicle speed signal circuit is open or shorted)</li> <li>● Wheel sensor</li> <li>● Combination meter</li> <li>● ABS actuator and electric unit (control unit)</li> </ul>

### DTC Confirmation Procedure

UBS00NII

#### CAUTION:

Always drive vehicle at a safe speed.

#### NOTE:

If DTC Confirmation Procedure has been previously conducted, always turn ignition switch OFF and wait at least 10 seconds before conducting the next test.

#### TESTING CONDITION:

Steps 1 and 2 may be conducted with the drive wheels lifted in the shop or by driving the vehicle. If a road test is expected to be easier, it is unnecessary to lift the vehicle.

#### WITH CONSULT-II

1. Start engine (VDC switch OFF).
2. Read "VHCL SPEED SE" in "DATA MONITOR" mode with CONSULT-II. The vehicle speed on CONSULT-II should exceed 10 km/h (6 MPH) when rotating wheels with suitable gear position.  
If NG, go to [EC-449, "Diagnostic Procedure"](#).  
If OK, go to following step.
3. Select "DATA MONITOR" mode with CONSULT-II.
4. Warm engine up to normal operating temperature.
5. Maintain the following conditions for at least 60 consecutive seconds.

ENG SPEED	More than 1,600 rpm
COOLAN TEMP/S	More than 70°C (158°F)
B/FUEL SCHDL	More than 6.9 msec
Selector lever	Except P or N position
PW/ST SIGNAL	OFF

6. If 1st trip DTC is detected, go to [EC-449, "Diagnostic Procedure"](#)

DATA MONITOR	
MONITOR	NO DTC
ENG SPEED	XXX rpm
COOLAN TEMP/S	XXX °C
B/FUEL SCHDL	XXX msec
PW/ST SIGNAL	OFF
VHCL SPEED SE	XXX km/h

SEF196Y

### Overall Function Check

UBS00NIJ

Use this procedure to check the overall function of the vehicle speed sensor circuit. During this check, a 1st trip DTC might not be confirmed.

# DTC P1217 ENGINE OVER TEMPERATURE

## 4. CHECK COOLING SYSTEM FOR LEAK

Apply pressure to the cooling system with a tester, and check if the pressure drops.

**Testing pressure: 157 kPa (1.6 kg/cm<sup>2</sup> , 23 psi)**

### CAUTION:

Higher than the specified pressure may cause radiator damage. Pressure should not drop.

OK or NG

OK >> GO TO 5.

NG >> Check the following for leak. Refer to [CO-10, "CHECKING COOLING SYSTEM FOR LEAKS"](#).

- Hose
- Radiator
- Radiator cap
- Water pump
- Reservoir tank

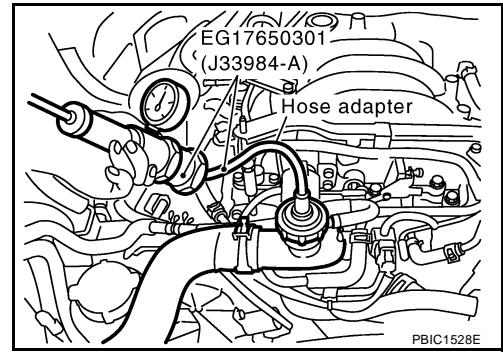

## 5. CHECK RESERVOIR TANK CAP

Apply pressure to cap with a tester.

**Reservoir tank cap relief pressure: 95 - 125 kPa (0.97 - 1.28 kg/cm<sup>2</sup> , 14 - 18 psi)**

OK or NG

OK >> GO TO 6.

NG >> Replace radiator cap.

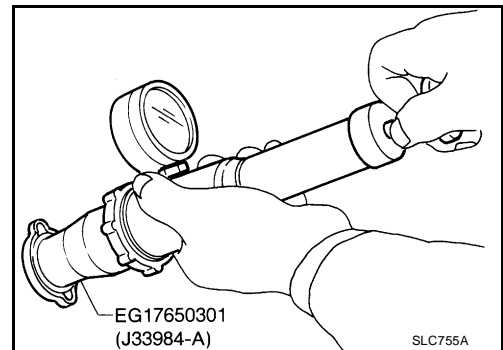

## 6. CHECK THERMOSTAT

1. Check valve seating condition at normal room temperatures. **It should seat tightly.**

2. Check valve opening temperature and valve lift.

**Valve opening temperature: 82°C (180°F) [standard]**

**Valve lift: More than 10.0 mm/95°C (0.394 in/203°F)**

3. Check if valve is closed at 5°C (9°F) below valve opening temperature.

For details, refer to [CO-21, "THERMOSTAT AND WATER PIPING"](#).

OK or NG

OK >> GO TO 7.

NG >> Replace thermostat

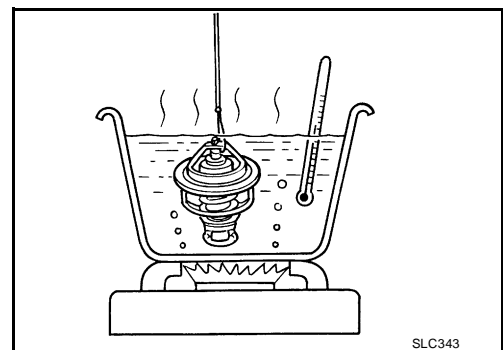

## 7. CHECK ENGINE COOLANT TEMPERATURE SENSOR

Refer to [EC-202, "Component Inspection"](#).

OK or NG

OK >> GO TO 8.

NG >> Replace engine coolant temperature sensor.

# DTC P1805 BRAKE SWITCH

UBS00NL7

## Component Inspection STOP LAMP SWITCH

1. Disconnect stop lamp switch harness connector.

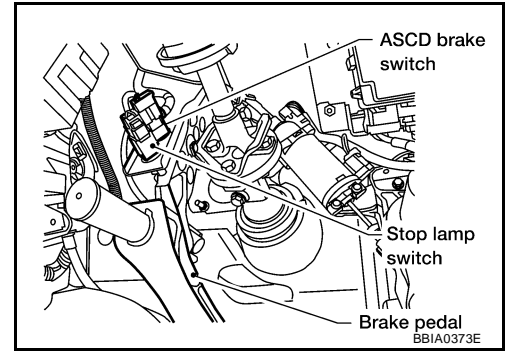

2. Check continuity between stop lamp switch terminals 1 and 2 under the following conditions.

Conditions	Continuity
Brake pedal: Fully released	Should not exist.
Brake pedal: Slightly depressed	Should exist.

3. If NG, adjust stop lamp switch installation, refer to [BR-6](#), "[BRAKE PEDAL](#)", and perform step 2 again.

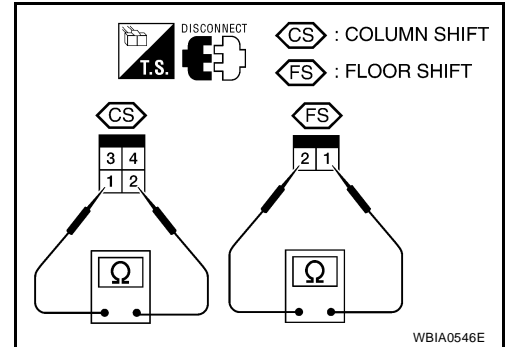

CLICK HERE TO **DOWNLOAD** THE COMPLETE MANUAL

- Thank you very much for reading the preview of the manual.
- You can download the complete manual from: [www.heydownloads.com](http://www.heydownloads.com) by clicking the link below



- Please note: If there is no response to CLICKING the link, please download this PDF first and then click on it.

CLICK HERE TO **DOWNLOAD** THE COMPLETE MANUAL

# DTC P2135 TP SENSOR

## 2. CHECK THROTTLE POSITION SENSOR POWER SUPPLY CIRCUIT-I

1. Disconnect electric throttle control actuator harness connector.
2. Turn ignition switch ON.

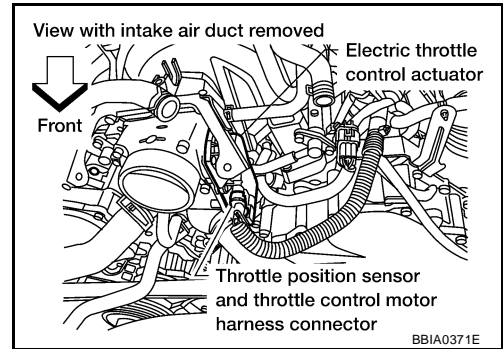

3. Check voltage between electric throttle control actuator terminal 2 and ground with CONSULT-II or tester.

**Voltage: Approximately 5V**

OK or NG

- OK >> GO TO 7.
- NG >> GO TO 3.

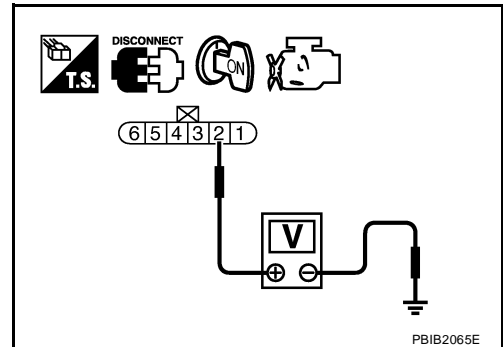

## 3. CHECK THROTTLE POSITION SENSOR POWER SUPPLY CIRCUIT-II

1. Turn ignition switch OFF.
2. Disconnect ECM harness connector.
3. Check harness continuity between electric throttle control actuator terminal 2 and ECM terminal 47. Refer to Wiring Diagram.

**Continuity should exist.**

OK or NG

- OK >> GO TO 4.
- NG >> Repair open circuit.

## 4. CHECK THROTTLE POSITION SENSOR POWER SUPPLY CIRCUIT-III

Check harness for short to power and short to ground, between the following terminals.

ECM terminal	Sensor terminal	Reference Wiring Diagram
47	Electric throttle control actuator terminal 2	<a href="#">EC-557</a>
91	APP sensor terminal 6	<a href="#">EC-564</a>

OK or NG

- OK >> GO TO 5.
- NG >> Repair short to ground or short to power in harness or connectors.

## 5. CHECK ACCELERATOR PEDAL POSITION SENSOR

Refer to [EC-569, "Component Inspection"](#) .

OK or NG

- OK >> GO TO 11.
- NG >> GO TO 6.

# FUEL INJECTOR

## 3. CHECK FUEL INJECTOR POWER SUPPLY CIRCUIT

1. Turn ignition switch OFF.
2. Disconnect fuel injector harness connector.

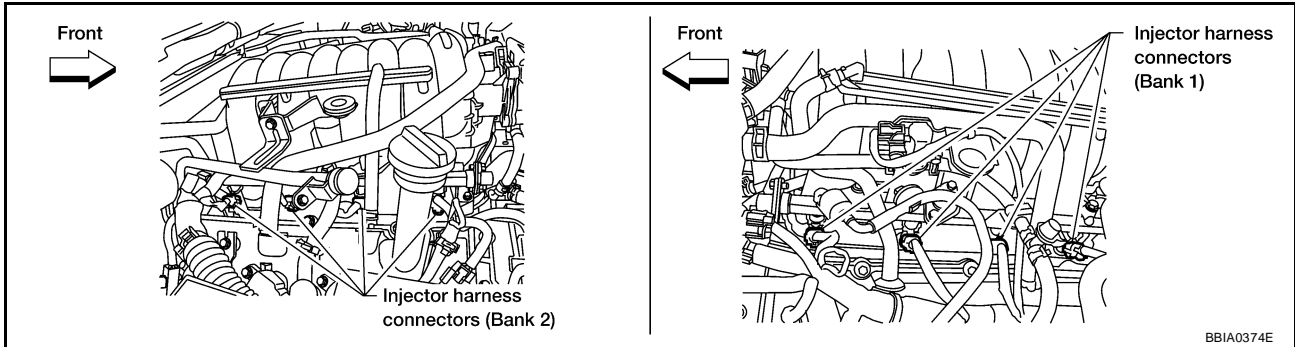

3. Turn ignition switch ON.
4. Check voltage between fuel injector terminal 1 and ground with CONSULT-II or tester.

**Voltage: Battery voltage**

OK or NG

- OK >> GO TO 5.
- NG >> GO TO 4.

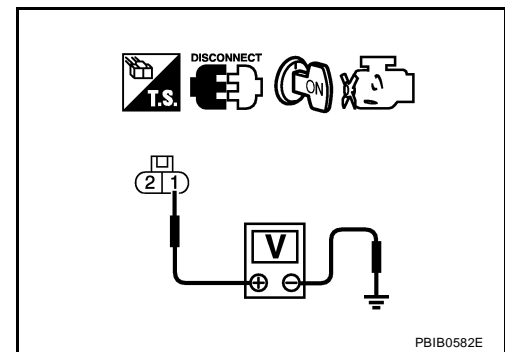

## 4. DETECT MALFUNCTIONING PART

Check the following.

- Harness connectors E2, F32
- IPDM E/R connector E119
- 15A fuse
- Harness for open or short between fuel injector and fuse

>> Repair harness or connectors.

## 5. CHECK FUEL INJECTOR OUTPUT SIGNAL CIRCUIT FOR OPEN AND SHORT

1. Turn ignition switch OFF.
2. Disconnect ECM harness connector.
3. Check harness continuity between fuel injector terminal 2 and ECM terminals 21, 22, 23, 40, 41, 42, 44, 63.  
Refer to Wiring Diagram.

**Continuity should exist.**

4. Also check harness for short to ground and short to power.

OK or NG

- OK >> GO TO 6.
- NG >> Repair open circuit or short to ground or short to power in harness or connectors.

**SECTION EI**  
**EXTERIOR & INTERIOR**

A  
B  
C  
D  
E  
F  
G  
H  
EI  
J  
K  
L  
M

**CONTENTS**

<b>PRECAUTIONS</b> .....	<b>3</b>	<b>FRONT GRILLE</b> .....	<b>20</b>
Service Notice .....	3	Removal and Installation .....	20
Precautions for Supplemental Restraint System (SRS) "AIR BAG" and "SEAT BELT PRE-TEN- SIONER" .....	3	REMOVAL .....	20
<b>PREPARATION</b> .....	<b>4</b>	INSTALLATION .....	20
Special Service Tools .....	4	<b>COWL TOP</b> .....	<b>21</b>
Commercial Service Tools .....	4	Removal and Installation .....	21
<b>SQUEAK AND RATTLE TROUBLE DIAGNOSES</b> .....	<b>5</b>	REMOVAL .....	21
Work Flow .....	5	INSTALLATION .....	22
CUSTOMER INTERVIEW .....	5	<b>FRONT FENDER</b> .....	<b>23</b>
DUPLICATE THE NOISE AND TEST DRIVE .....	6	Removal and Installation .....	23
CHECK RELATED SERVICE BULLETINS .....	6	REMOVAL .....	23
LOCATE THE NOISE AND IDENTIFY THE ROOT CAUSE .....	6	INSTALLATION .....	23
REPAIR THE CAUSE .....	6	<b>FENDER PROTECTOR</b> .....	<b>24</b>
CONFIRM THE REPAIR .....	7	Removal and Installation .....	24
Generic Squeak and Rattle Troubleshooting .....	7	REMOVAL .....	24
INSTRUMENT PANEL .....	7	INSTALLATION .....	24
CENTER CONSOLE .....	7	<b>RUNNING BOARDS</b> .....	<b>25</b>
DOORS .....	7	Removal and Installation .....	25
TRUNK .....	8	REMOVAL .....	26
SUNROOF/HEADLINING .....	8	INSTALLATION .....	26
OVERHEAD CONSOLE (FRONT AND REAR).....	8	<b>MUDGUARD</b> .....	<b>27</b>
SEATS .....	8	Removal and Installation .....	27
UNDERHOOD .....	8	<b>DOOR OUTSIDE MOLDING</b> .....	<b>28</b>
Diagnostic Worksheet .....	9	Removal and Installation .....	28
<b>CLIP AND FASTENER</b> .....	<b>11</b>	FRONT DOOR OUTSIDE MOLDING .....	29
Clip and Fastener .....	11	REAR DOOR OUTSIDE MOLDING .....	29
<b>FRONT BUMPER</b> .....	<b>14</b>	<b>SIDE GUARD MOLDING</b> .....	<b>30</b>
Removal and Installation .....	14	Removal and Installation .....	30
STEEL BUMPER .....	14	REMOVAL .....	31
PLASTIC BUMPER .....	16	INSTALLATION .....	31
<b>REAR BUMPER</b> .....	<b>18</b>	<b>DOOR FINISHER</b> .....	<b>32</b>
Removal and Installation .....	18	Removal and Installation .....	32
REMOVAL .....	18	FRONT DOOR .....	32
INSTALLATION .....	19	REAR DOOR - CREW CAB .....	33
		REAR DOOR - KING CAB .....	35

# BODY SIDE TRIM

---

## LOWER DASH SIDE FINISHER

### Removal

1. Remove push pin from lower dash side finisher.
2. Remove front kicking plate. Refer to [EI-38, "KICKING PLATES"](#) .
3. Remove lower dash side finisher and front kicking plate together.
4. Remove lower dash side finisher from front kicking plate.

### Installation

Installation is in the reverse order of removal.

## CENTER PILLAR LOWER FINISHER

### Removal

1. Remove seat belt lower anchor. Refer to [SB-3, "Removal and Installation of Front Seat Belt"](#) .
  - On RH side, disconnect seat belt tension sensor.
2. Remove front and rear kicking plates. Refer to [EI-38, "KICKING PLATES"](#) .
3. Remove center pillar lower finisher.

### Installation

Installation is in the reverse order of removal.

## CENTER PILLAR UPPER FINISHER

### Removal

1. Remove front and rear door welts.
2. Remove front and rear kicking plates. Refer to [EI-38, "KICKING PLATES"](#) .
3. Remove center pillar lower finisher. Refer to [EI-38, "CENTER PILLAR LOWER FINISHER"](#) .
4. Remove seat belt shoulder anchor and D ring. Refer to [SB-3, "Removal and Installation of Front Seat Belt"](#) .
5. Remove center pillar assist grip.
6. Remove center pillar upper finisher.

### Installation

Installation is in the reverse order of removal.

## FRONT PILLAR FINISHER

### Removal

1. Remove front pillar assist grip.
2. Remove front pillar finisher.

### Installation

Installation is in the reverse order of removal.

## KICKING PLATES

### Removal and Installation

Release clips and remove front and/or rear kicking plates.

Installation is in the reverse order of removal.

## DOOR PARTING SEALS

### Removal

1. Open front and/or rear doors fully.
2. Release clips and remove parting seals.

### Installation

Installation is in the reverse order of removal.

## EXHAUST MANIFOLD AND THREE WAY CATALYST

- Tighten the exhaust manifold nuts in the numerical order shown. Then recheck the torque of the nuts both (A) and (B).

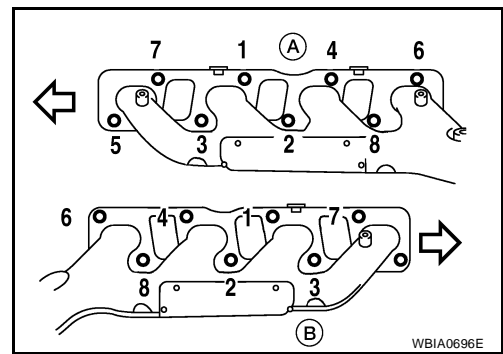

- Before installing new air fuel ratio A/F sensors, clean the exhaust system threads using Tool and apply anti-seize lubricant.

**Tool number** : J-43879-12

: J-43897-18

### CAUTION:

- Do not over tighten the air fuel ratio A/F sensors. Doing so may cause damage to the sensor, resulting in the MIL coming on.

## OIL SEAL

### Removal and Installation of Valve Oil Seal

#### REMOVAL

1. Remove the camshaft relating to the valve oil seal to be removed. Refer to [EM-46, "Removal and Installation"](#) .
2. Remove the valve lifters. Refer to [EM-46, "Removal and Installation"](#) .
  - Correctly identify the location where each part is removed from. Keep parts organized to avoid mixing them up.
3. Turn the crankshaft until the cylinder requiring new oil seals is at TDC. This will prevent the valve from dropping into the cylinder.

4. Remove the valve collet using Tool.

**Tool number** : KV10116200 (J-26336-A)  
 : KV10115900 (J-26336-20)  
 : KV10109220 ( — )

**CAUTION:**

**Do not damage the valve lifter holes.**

5. Remove the valve spring retainer and valve spring.

**CAUTION:**

**Do not remove the valve spring seat from the valve spring.**

6. Remove the valve oil seal using Tool.

**Tool number** : KV10107902 (J-38959)

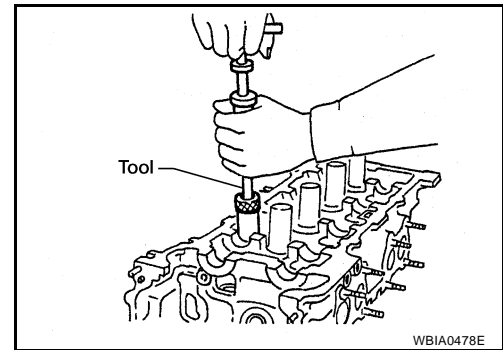
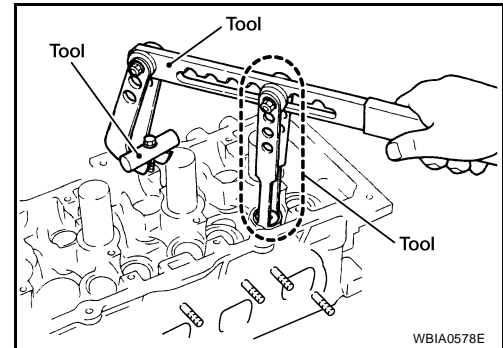

#### INSTALLATION

Installation is in the reverse order of removal.

- Install the valve oil seal using Tool.

**Tool number** : KV10115600 (J-38958)

- Apply new engine oil on the new valve oil seal joint and seal lip.
- Install the valve oil seal to the specified height "H".

**Height "H" (without valve spring installed)**

**Intake and exhaust : 14.3 - 14.9 mm (0.563 - 0.587 in)**

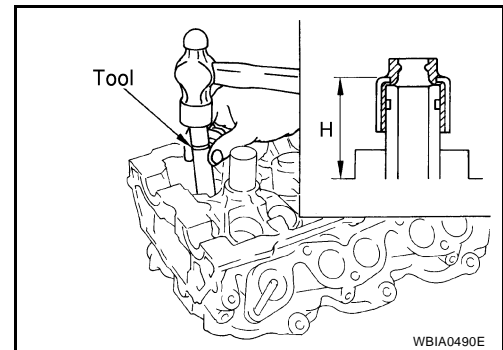

# CYLINDER BLOCK

## Piston Pin Diameter

- Measure diameter of piston pin using suitable tool.

**Standard : 21.989 - 21.995 mm (0.8657 - 0.8659 in)**

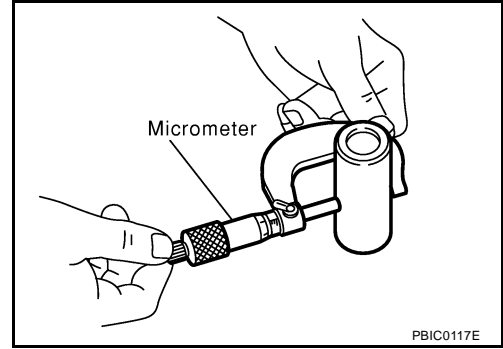

## Connecting Rod Bushing Oil Clearance (Small End)

(Connecting rod small end oil clearance) = (Inside diameter of connecting rod small end) – (Piston pin diameter)

**Standard : 0.005 - 0.017 mm (0.0002 - 0.0007 in)**

- If measured value exceeds the standard, replace the connecting rod assembly and/or piston and piston pin assembly.
- If replacing the piston and piston pin assembly, refer to the Table for Selective Fitting for Piston to select the piston corresponding to the applicable bore grade of the cylinder block to be used. Refer to [EM-87, "HOW TO SELECT PISTON"](#).

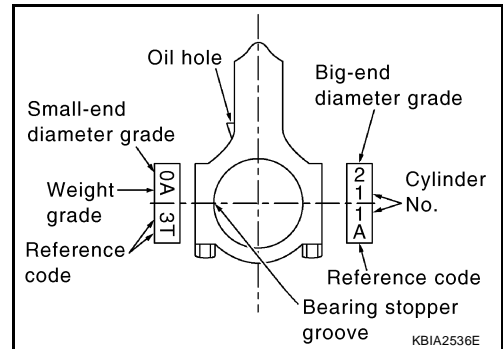

## Factory installed parts grading:

- Only grade 0 is available.

	Unit: mm (in)
Grade	0
Connecting rod bushing inside diameter	22.000 - 22.006 (0.8661 - 0.8664)
Piston pin diameter	21.989 - 21.995 (0.8657 - 0.8659)
Piston pin hole diameter	21.993 - 21.999 (0.8659 - 0.8661)

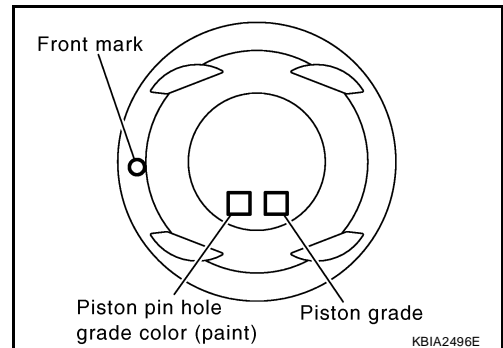

## CYLINDER BLOCK DISTORTION

- Remove any oil, scale, gasket, sealant and carbon deposits from the cylinder block surface.

### CAUTION:

**Do not allow any debris to enter the oil or coolant passages.**

- Measure block upper face for distortion in six directions as shown.

**Standard : 0.03 mm (0.0012 in)**

**Limit : 0.1 mm (0.004 in)**

- If measurement exceeds the limit, replace cylinder block.

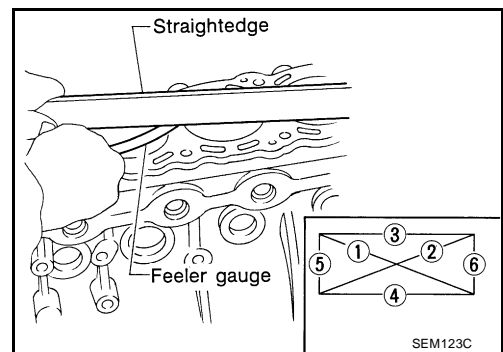

# SERVICE DATA AND SPECIFICATIONS (SDS)

---

# FUEL SYSTEM

- After connecting the fuel tube quick connectors, make sure the quick connectors are secure. Ensure that the connector and resin tube do not contact any adjacent parts.
- After installing tubes, make sure there is no fuel leakage at connections in the following steps.
- Apply fuel pressure to fuel lines with turning ignition switch ON (with engine stopped). Then check for fuel leaks at connections.
- Start the engine and rev it up and check for fuel leaks at connections.
- Use only a Genuine NISSAN fuel filler cap as a replacement. If an incorrect fuel filler cap is used, the MIL may come on.
- For servicing "Evaporative Emission System" parts, refer to [EC-32, "EVAPORATIVE EMISSION SYSTEM"](#) .
- For servicing "On Board Refueling Vapor Recovery (ORVR)" parts, refer to [EC-39, "ON BOARD REFUELING VAPOR RECOVERY \(ORVR\)"](#) .

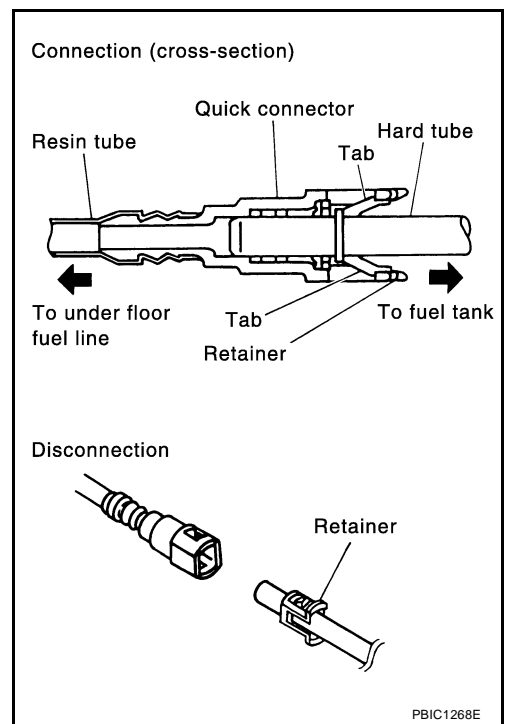

A

FL

C

D

E

F

G

H

I

J

K

L

M

# PRECAUTIONS

## Precautions for Multiport Fuel Injection System or Engine Control System

EAS001D6

- Before connecting or disconnecting any harness connector for the multiport fuel injection system or ECM:  
Turn ignition switch to "OFF" position.  
Disconnect negative battery terminal.  
Otherwise, there may be damage to ECM.
- Before disconnecting pressurized fuel line from fuel pump to injectors, be sure to release fuel pressure.
- Be careful not to jar components such as ECM and mass air flow sensor.



## Precautions for Hoses HOSE REMOVAL AND INSTALLATION

EAS001D7

- To prevent damage to rubber hose, do not pry off rubber hose with tapered tool or screwdriver.

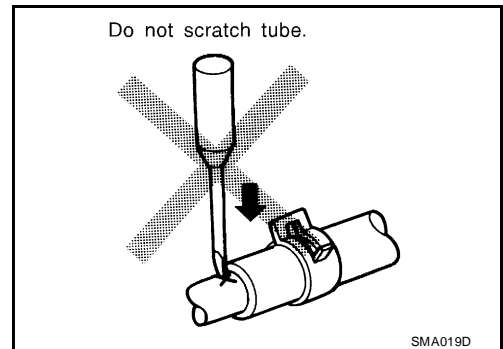

- To reinstall the rubber hose securely, make sure of hose insertion length and clamp orientation. (If tube is equipped with hose stopper, insert rubber hose into tube until it butts up against hose stopper.)

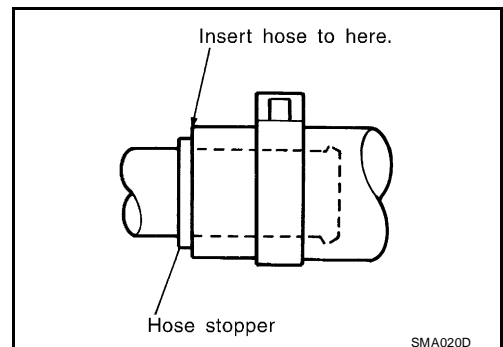

## HOSE CLAMPING

- If old rubber hose is re-used, install hose clamp in its original position (at the indentation where the old clamp was). If there is a trace of tube bulging left on the old rubber hose, align rubber hose at that position.

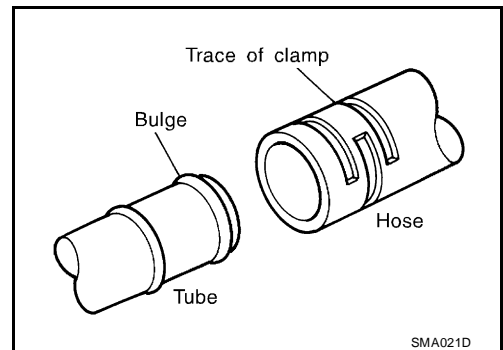

- Discard old clamps; replace with new ones.

# TOW TRUCK TOWING

## Towing Point

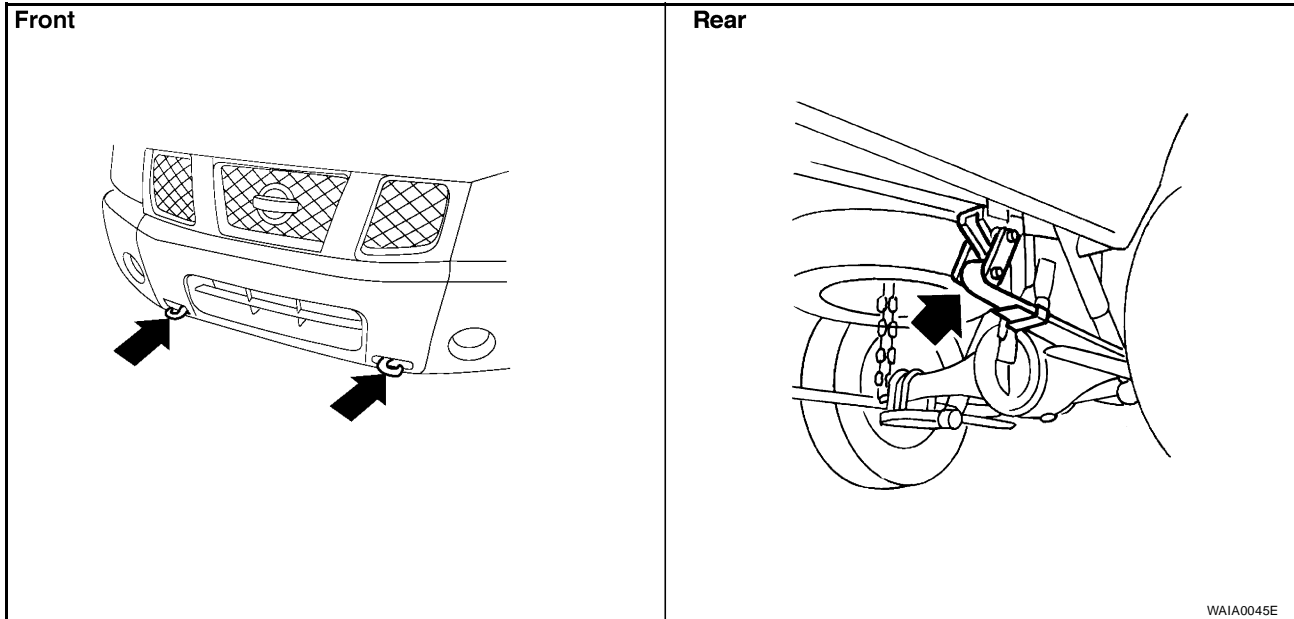

### CAUTION:

Never tow the vehicle using only the towing points. To avoid damaging the vehicle body, use proper towing equipment when towing.

### 4WD MODEL

NISSAN does not recommend towing automatic transmission equipped vehicles with the drive wheels on the ground.

### CAUTION:

- Never tow 4WD models with any of the tires on the ground as this may cause serious and expensive damage to the transfer case and transmission.

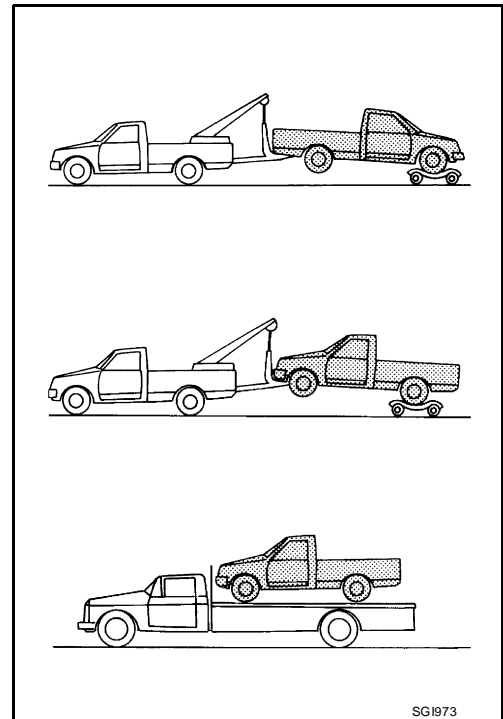

## Vehicle Recovery (Freeing a stuck vehicle)

EAS001DV

- Tow chains or cables must be attached only to the main structural members of the vehicle.
- Pulling devices should be routed so they do not touch any part of the suspension, steering, brake or cooling systems
- Always pull the cable straight out from the front or rear of the vehicle. Never pull the vehicle at a sideways angle.
- Pulling devices such as ropes or canvas straps are not recommended for use for vehicle towing or recovery.

# POWER WINDOW SYSTEM

## Schematic (King Cab)

EIS004CB

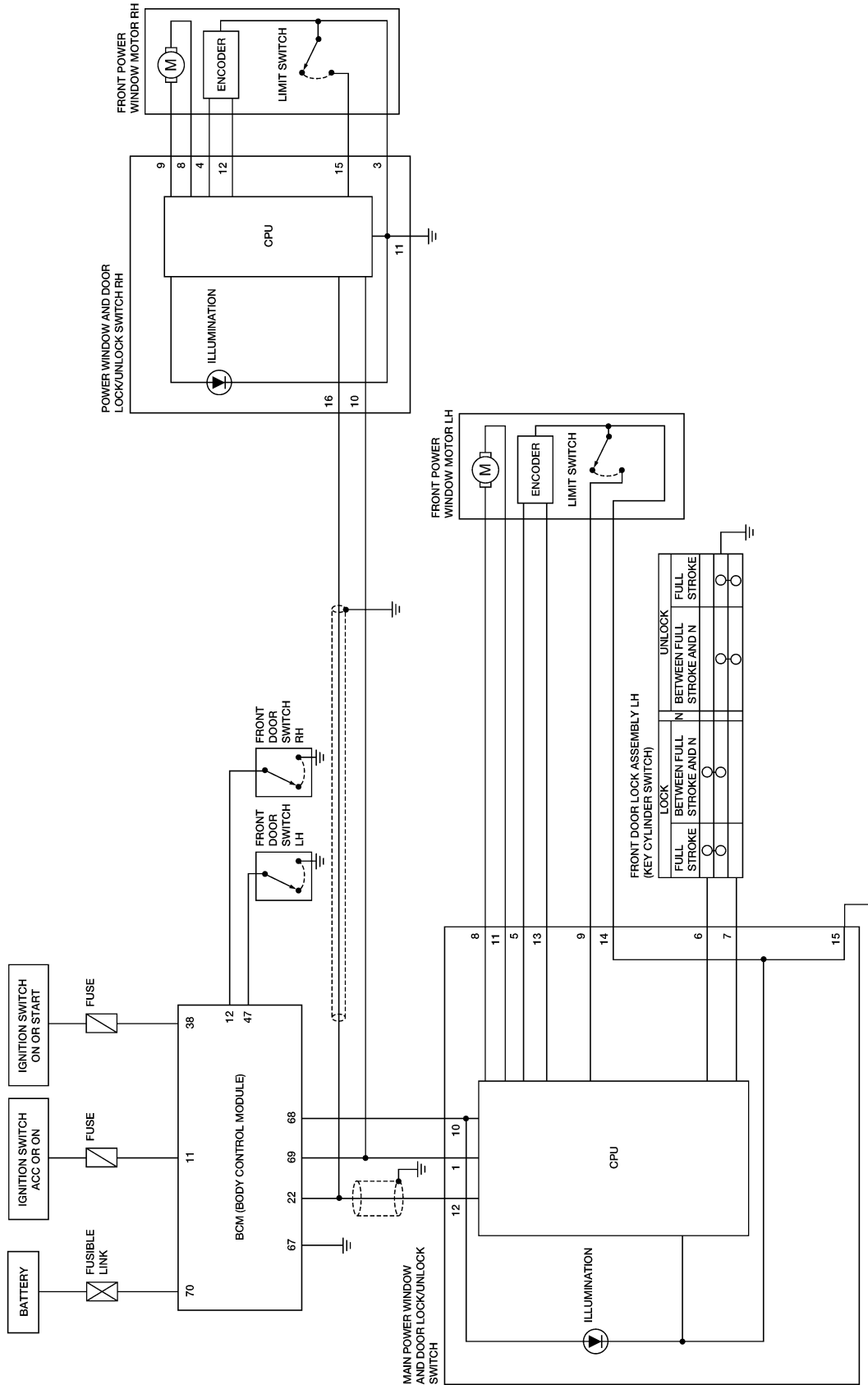

WIWA1374E

# POWER WINDOW SYSTEM

## 4. CHECK ENCODER GROUND CIRCUIT

1. Disconnect main power window and door lock/unlock switch.
2. Check continuity between front power window motor LH connector D9 terminal 6 and main power window and door lock/unlock switch connector D7 terminal 14.

**6 - 14** : Continuity should exist.

OK or NG

- OK >> Replace main power window and door lock/unlock switch. Refer to [EI-32, "FRONT DOOR"](#).
- NG >> Repair or replace harness.

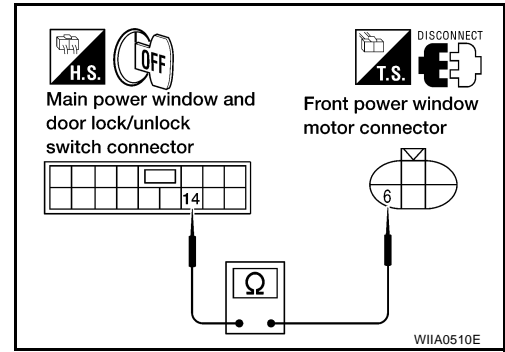

## 5. CHECK ENCODER SIGNAL

1. Connect front power window motor LH and main power window and door lock/unlock.
2. Turn ignition switch ON.
3. Check the signal between main power window and door lock/unlock switch connector and ground with oscilloscope.

Connector	Terminals		Condition	Signal
	(+)	(-)		
D7	13	Ground	Opening	<p>The graph shows a square wave pulse on a grid. The vertical axis is labeled (V) with values 0, 2, 4, 6. The horizontal axis is labeled 10mS. The pulse reaches approximately 5V and has a width of about 2mS.</p>

OCC3383D

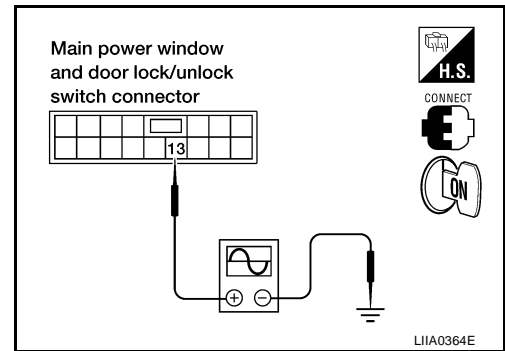

OK or NG

- OK >> Replace main power window and door lock/unlock switch. Refer to [EI-32, "FRONT DOOR"](#).
- NG >> GO TO 6.

# REAR WINDOW DEFOGGER

GW-DEF-02

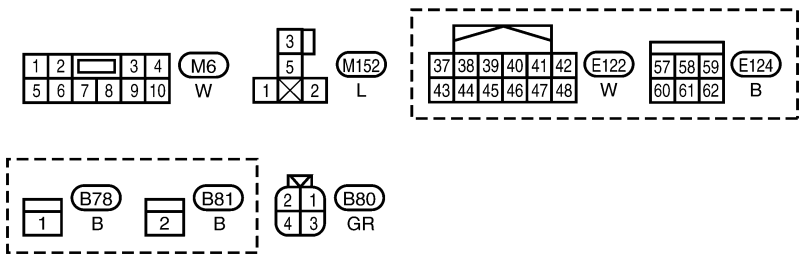
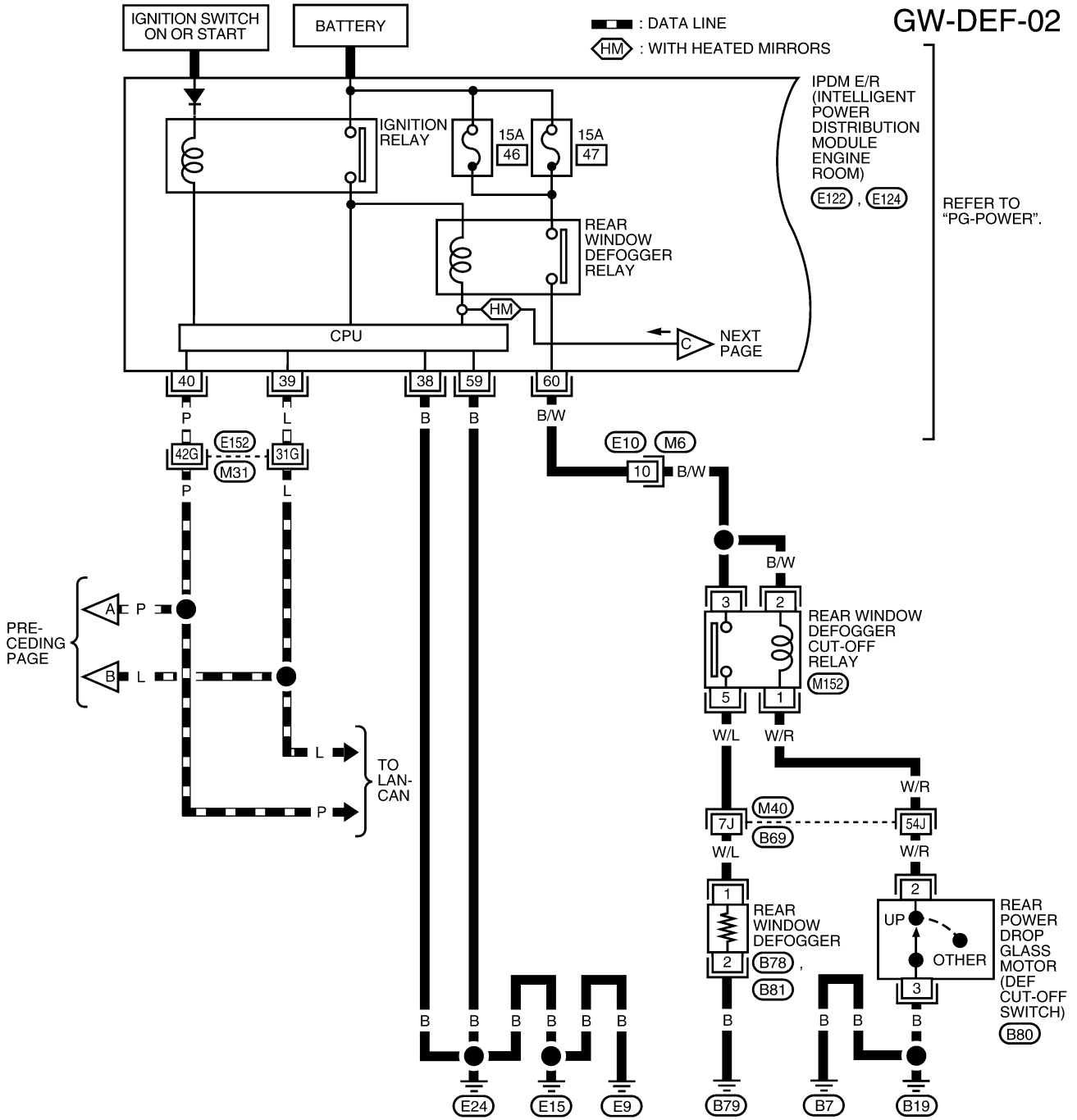

REFER TO THE FOLLOWING.  
 (M31), (M40) - SUPER  
 MULTIPLE JUNCTION (SMJ)

WIWA1385E

# PREPARATION

## PREPARATION

PFP:00002

### Special Service Tools

EIS004EX

The actual shapes of Kent-Moore tools may differ from those of special service tools illustrated here.

Tool number (Kent-Moore No.) Tool name	Description
— (J-39570) Chassis ear	Locating the noise
— (J-43980) NISSAN Squeak and Rattle kit	Repairing the cause of noise

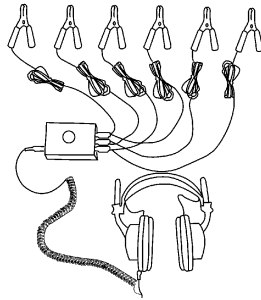

SBT839

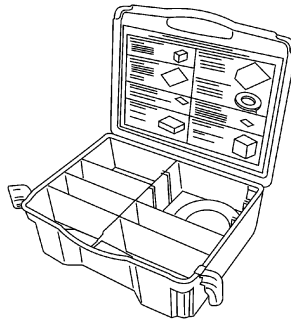

SBT840

### Commercial Service Tools

EIS004EY

(Kent-Moore No.) Tool name	Description
(J-39565) Engine ear	Locating the noise
Power Tool	Loosening bolts and nuts

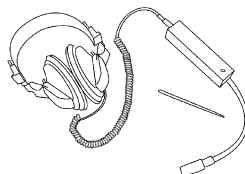

SIIA0995E

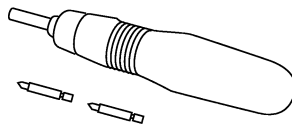

PBIC0191E

# TROUBLE DIAGNOSES WORK FLOW

[CAN]

## ABLS models

(Example) CAN DIAG SUPPORT MNTR

ABS			
	PRSNT		
INITIAL DIAG	OK		
TRANSMIT DIAG	OK		
ECM	OK		
TCM	OK		
PRINT			
MODE	BACK	LIGHT	COPY

SKIB0594E

“SELECT SYSTEM” screen	“CAN DIAG SUPPORT MNTR” screen	Description	Present
ABS	INITIAL DIAG	Make sure that microcomputer in ECU works normally.	OK/NG
	TRANSMIT DIAG	Make sure of normal transmission.	OK/UNKWN
	ECM	Make sure of normal reception from ECM.	OK/UNKWN
	TCM	Make sure of normal reception from TCM.	OK/UNKWN

### Display Results (Present)

- OK: Normal
- NG: Malfunction
- UNKWN: The diagnosed unit does not transmit or receive the applicable data normally.

## VDC models

(Example) CAN DIAG SUPPORT MNTR

ABS			
	PRSNT		
INITIAL DIAG	OK		
TRANSMIT DIAG	OK		
ECM	OK		
TCM	OK		
METER/M&A	UNKWN		
STRG	OK		
ICC	UNKWN		
AWD/4WD	OK		
PRINT			
MODE	BACK	LIGHT	COPY

PKIB6078E

“SELECT SYSTEM” screen	“CAN DIAG SUPPORT MNTR” screen	Description	Present
ABS	INITIAL DIAG	Make sure that microcomputer in ECU works normally.	OK/NG
	TRANSMIT DIAG	Make sure of normal transmission.	OK/UNKWN
	ECM	Make sure of normal reception from ECM.	OK/UNKWN
	TCM	Make sure of normal reception from TCM.	OK/UNKWN
	METER/M&A	METER/M&A is not diagnosed.	UNKWN
	STRG	Make sure of normal reception from steering angle sensor.	OK/UNKWN
	ICC	ICC is not diagnosed.	UNKWN
	AWD/4WD	Make sure of normal reception from transfer control unit.	OK/UNKWN

### Display Results (Present)

- OK: Normal
- NG: Malfunction
- UNKWN: The diagnosed unit does not transmit or receive the applicable data normally.

# CAN SYSTEM (TYPE 1)

[CAN]

## Case 6

Check BCM circuit. Refer to [LAN-359, "BCM Circuit Inspection"](#).

SELECT SYSTEM screen		CAN DIAG SUPPORT MNTR								SELF-DIAG RESULTS	
		Initial diagnosis	Transmit diagnosis	Receive diagnosis							
				ECM	TCM	METER /M&A	BCM/SEC	VDC/TCS /ABS	IPDM E/R		
ENGINE	—	—	UNKWN	—	UNKWN	UNKWN	UNKWN	—	UNKWN	CAN COMM CIRCUIT (U1000)	CAN COMM CIRCUIT (U1001)
A/T	—	NG	UNKWN	UNKWN	—	UNKWN	—	—	—	CAN COMM CIRCUIT (U1000)	—
BCM	No indication	NG	UNKWN	UNKWN	—	UNKWN	—	—	UNKWN	CAN COMM CIRCUIT (U1000)	—
HVAC	No indication	—	UNKWN	UNKWN	—	—	UNKWN	UNKWN	UNKWN	—	—
ABS	—	NG	UNKWN	UNKWN	—	—	—	—	—	CAN COMM CIRCUIT (U1000)	—
IPDM E/R	No indication	—	UNKWN	UNKWN	—	—	UNKWN	—	—	CAN COMM CIRCUIT (U1000)	—

PKIC2959E

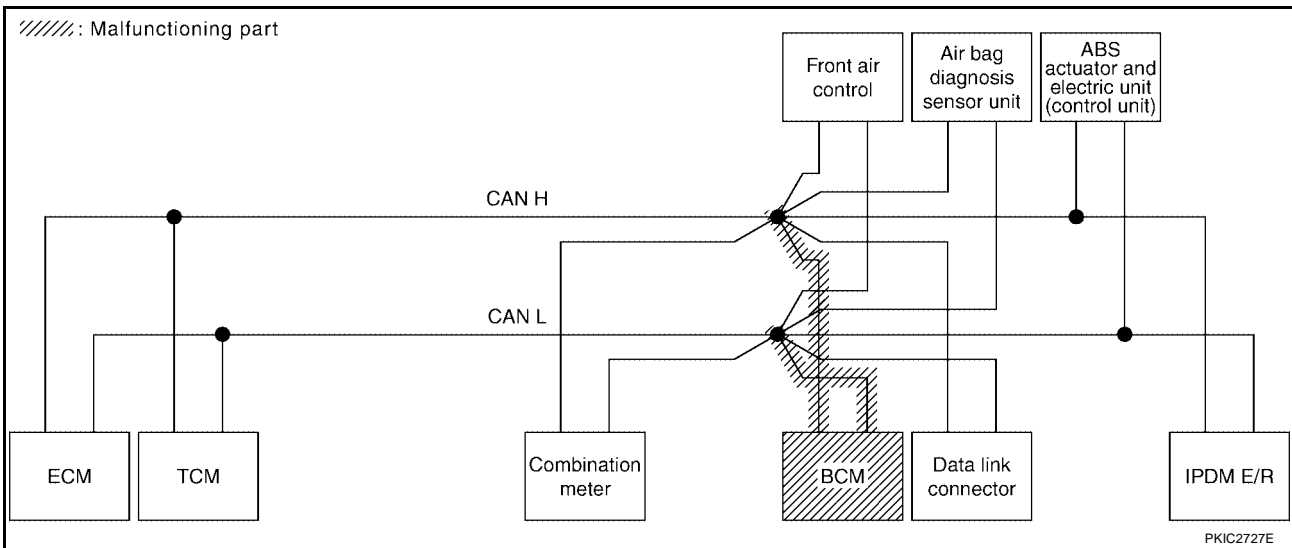

# CAN SYSTEM (TYPE 4)

[CAN]

UKS004Q0

## Check Sheet

**NOTE:**

If a check mark is put on "NG" on "INITIAL DIAG (Initial diagnosis)", replace the control unit.

Check sheet table												SELF-DIAG RESULTS		
SELECT SYSTEM screen		CAN DIAG SUPPORT MNTR												
		Initial diagnosis	Transmit diagnosis	Receive diagnosis										
				ECM	TCM	METER /M&A	DISPLAY	BCM/SEC	HVAC	VDC/TCS /ABS	IPDM E/R			
ENGINE	-	-	UNKWN	-	UNKWN	UNKWN	-	UNKWN	-	UNKWN	UNKWN	CAN COMM CIRCUIT (U1000)	-	CAN COMM CIRCUIT (U1001)
A/T	-	NG	UNKWN	UNKWN	-	UNKWN	-	-	-	UNKWN	-	CAN COMM CIRCUIT (U1000)	-	-
AUTO DRIVE POS.	No indication	-	-	-	UNKWN	UNKWN	-	UNKWN	-	-	-	CAN COMM CIRCUIT (U1000)	-	-
Display control unit	-	NG	UNKWN	UNKWN	-	UNKWN	-	UNKWN	UNKWN	-	UNKWN	-	-	-
BCM	No indication	NG	UNKWN	UNKWN	-	UNKWN	-	-	-	-	UNKWN	CAN COMM CIRCUIT (U1000)	-	-
HVAC	No indication	-	UNKWN	UNKWN	-	-	UNKWN	UNKWN	-	UNKWN	-	-	-	-
ABS	-	NG	UNKWN	UNKWN	UNKWN	-	-	-	-	-	-	CAN COMM CIRCUIT (U1000)	-	-
IPDM E/R	No indication	-	UNKWN	UNKWN	-	-	-	UNKWN	-	-	-	CAN COMM CIRCUIT (U1000)	-	-

Symptoms :

Attach copy of  
SELECT SYSTEM

Attach copy of  
SELECT SYSTEM

Display control unit Translation Sheet: Rewrite the following names, and put a check mark on the above check sheet table.

Confirmation/Adjustment Display	Check sheet table Display	Confirmation/Adjustment Display	Check sheet table Display
CAN COMM	Initial diagnosis	CAN CIRC 5	METER/M&A
CAN CIRC 1	Transmit diagnosis	CAN CIRC 6	-
CAN CIRC 2	BCM	CAN CIRC 7	IPDM E/R
CAN CIRC 3	ECM	CAN CIRC 8	-
CAN CIRC 4	HVAC	CAN CIRC 9	-

Attach copy of  
display control unit  
CAN DIAG SUPPORT MONITOR check sheet

PKIC2940E

# CAN SYSTEM (TYPE 6)

[CAN]

## Case 4

Check ECM circuit. Refer to [LAN-356, "ECM Circuit Inspection"](#) .

SELECT SYSTEM screen		CAN DIAG SUPPORT MNTR									SELF-DIAG RESULTS	
		Initial diagnosis	Transmit diagnosis	Receive diagnosis								
				ECM	TCM	METER /M&A	BCM/SEC	STRG	VDC/TCS /ABS	IPDM E/R		
ENGINE	-	-	UNKW <sup>✓</sup> N	-	UNKW <sup>✓</sup> N	UNKW <sup>✓</sup> N	UNKW <sup>✓</sup> N	-	UNKW <sup>✓</sup> N	UNKW <sup>✓</sup> N	CAN COMM CIRCUIT (U1000) <sup>✓</sup>	CAN COMM CIRCUIT (U1001) <sup>✓</sup>
A/T	-	NG	UNKW <sup>✓</sup> N	UNKW <sup>✓</sup> N	-	UNKW <sup>✓</sup> N	-	-	UNKW <sup>✓</sup> N	-	CAN COMM CIRCUIT (U1000) <sup>✓</sup>	-
AUTO DRIVE POS.	No indication	-	-	-	UNKW <sup>✓</sup> N	UNKW <sup>✓</sup> N	UNKW <sup>✓</sup> N	-	-	-	CAN COMM CIRCUIT (U1000) <sup>✓</sup>	-
BCM	No indication	NG	UNKW <sup>✓</sup> N	UNKW <sup>✓</sup> N	-	UNKW <sup>✓</sup> N	-	-	-	UNKW <sup>✓</sup> N	CAN COMM CIRCUIT (U1000) <sup>✓</sup>	-
HVAC	No indication	-	UNKW <sup>✓</sup> N	UNKW <sup>✓</sup> N	-	-	UNKW <sup>✓</sup> N	-	UNKW <sup>✓</sup> N	-	-	-
ABS	-	NG	UNKW <sup>✓</sup> N	UNKW <sup>✓</sup> N	-	-	-	UNKW <sup>✓</sup> N	-	-	CAN COMM CIRCUIT (U1000) <sup>✓</sup>	-
IPDM E/R	No indication	-	UNKW <sup>✓</sup> N	UNKW <sup>✓</sup> N	-	-	UNKW <sup>✓</sup> N	-	-	-	CAN COMM CIRCUIT (U1000) <sup>✓</sup>	-

PKIC3261E

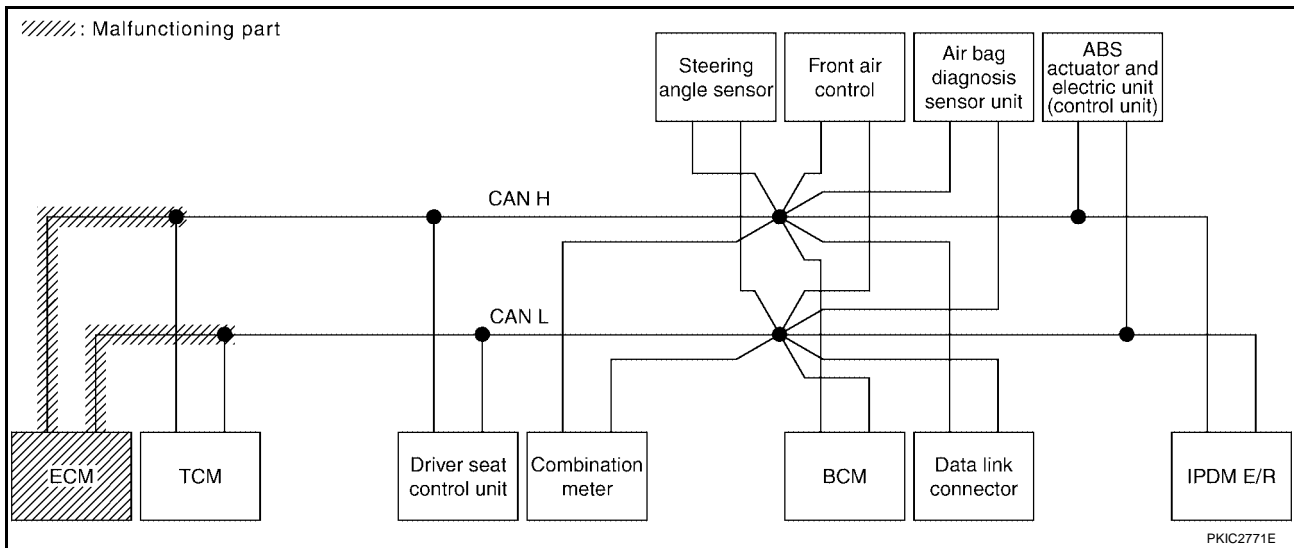

## Case 6

Check BCM circuit. Refer to [LAN-359, "BCM Circuit Inspection"](#) .

SELECT SYSTEM screen		CAN DIAG SUPPORT MNTR									SELF-DIAG RESULTS	
		Initial diagnosis	Transmit diagnosis	Receive diagnosis								
				ECM	TCM	METER /M&A	BCM/SEC	AWD/4WD	VDC/TCS /ABS	IPDM E/R		
ENGINE	–	–	UNKWN	–	UNKWN	UNKWN	UNKWN	UNKWN	UNKWN	UNKWN	CAN COMM CIRCUIT (U1000)	CAN COMM CIRCUIT (U1001)
A/T	–	NG	UNKWN	UNKWN	–	UNKWN	–	UNKWN	UNKWN	–	CAN COMM CIRCUIT (U1000)	–
BCM	No indication	NG	UNKWN	UNKWN	–	UNKWN	–	–	–	UNKWN	CAN COMM CIRCUIT (U1000)	–
HVAC	No indication	–	UNKWN	UNKWN	–	–	UNKWN	–	UNKWN	UNKWN	–	–
ALL MODE AWD/4WD	–	NG	UNKWN	UNKWN	UNKWN	UNKWN	–	–	UNKWN	–	CAN COMM CIRCUIT (U1000)	–
ABS	–	NG	UNKWN	UNKWN	UNKWN	–	–	UNKWN	–	–	CAN COMM CIRCUIT (U1000)	–
IPDM E/R	No indication	–	UNKWN	UNKWN	–	–	UNKWN	–	–	–	CAN COMM CIRCUIT (U1000)	–

PKIC3296E

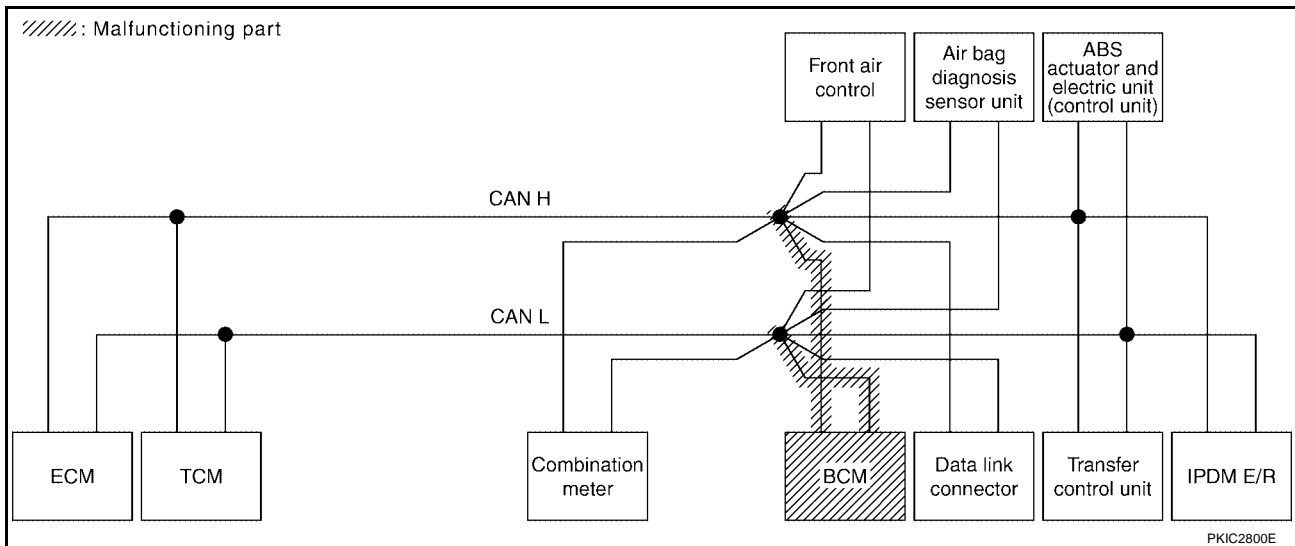

## Case 11

Check front air control circuit. Refer to [LAN-360, "Front Air Control Circuit Inspection"](#) .

SELECT SYSTEM screen		CAN DIAG SUPPORT MNTR											SELF-DIAG RESULTS			
		Initial diagnosis	Transmit diagnosis	Receive diagnosis											CAN COMM CIRCUIT (U1000)	CAN COMM CIRCUIT (U1001)
				ECM	TCM	METER /M&A	DISPLAY	BCM/SEC	HVAC	AWD/4WD	VDC/TCS /ABS	IPDM E/R				
ENGINE	-	-	UNKWN	-	UNKWN	UNKWN	-	UNKWN	-	UNKWN	UNKWN	UNKWN	CAN COMM CIRCUIT (U1000)	CAN COMM CIRCUIT (U1001)		
A/T	-	NG	UNKWN	UNKWN	-	UNKWN	-	-	-	UNKWN	UNKWN	-	CAN COMM CIRCUIT (U1000)	-		
AUTO DRIVE POS.	No indication	-	-	-	UNKWN	UNKWN	-	UNKWN	-	-	-	-	CAN COMM CIRCUIT (U1000)	-		
Display control unit	-	NG	UNKWN	UNKWN	-	UNKWN	-	UNKWN	UNKWN	-	-	UNKWN	-	-		
BCM	No indication	NG	UNKWN	UNKWN	-	UNKWN	-	-	-	-	-	UNKWN	CAN COMM CIRCUIT (U1000)	-		
HVAC	No indication	-	UNKWN	UNKWN	-	-	UNKWN	UNKWN	-	-	UNKWN	-	-	-		
ALL MODE AWD/4WD	-	NG	UNKWN	UNKWN	UNKWN	UNKWN	-	-	-	-	UNKWN	-	CAN COMM CIRCUIT (U1000)	-		
ABS	-	NG	UNKWN	UNKWN	UNKWN	-	-	-	-	UNKWN	-	-	CAN COMM CIRCUIT (U1000)	-		
IPDM E/R	No indication	-	UNKWN	UNKWN	-	-	-	UNKWN	-	-	-	-	CAN COMM CIRCUIT (U1000)	-		

PKIC3331E

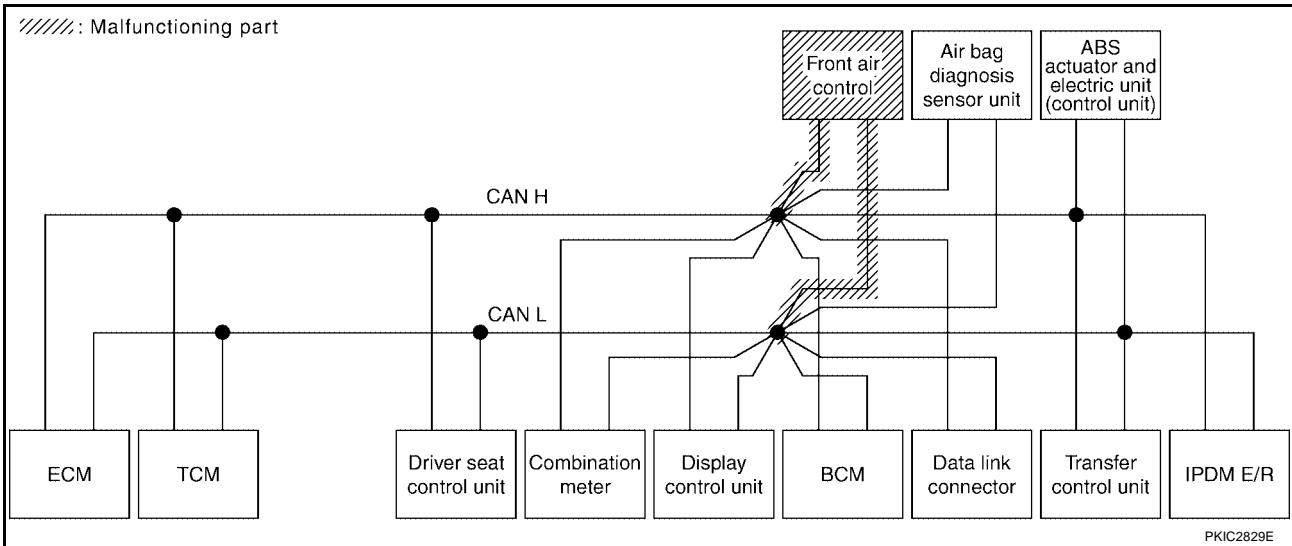

# CAN SYSTEM (TYPE 12)

[CAN]

## Case 12

Check front air control circuit. Refer to [LAN-360, "Front Air Control Circuit Inspection"](#) .

SELECT SYSTEM screen		CAN DIAG SUPPORT MNTR										SELF-DIAG RESULTS		
		Initial diagnosis	Transmit diagnosis	Receive diagnosis										
				ECM	TCM	DIFF LOCK	METER /M&A	BCM/SEC	AWD/4WD	VDC/TCS /ABS	IPDM E/R			
ENGINE	-	-	UNKWN	-	UNKWN	-	UNKWN	UNKWN	UNKWN	UNKWN	UNKWN	UNKWN	CAN COMM CIRCUIT (U1000)	CAN COMM CIRCUIT (U1001)
A/T	-	NG	UNKWN	UNKWN	-	-	UNKWN	-	UNKWN	UNKWN	UNKWN	-	CAN COMM CIRCUIT (U1000)	-
DIFF LOCK	-	NG	UNKWN	UNKWN	-	-	-	-	UNKWN	UNKWN	-	-	CAN COMM CIRCUIT (U1000)	-
AUTO DRIVE POS.	No indication	-	-	-	UNKWN	-	UNKWN	UNKWN	-	-	-	-	CAN COMM CIRCUIT (U1000)	-
BCM	No indication	NG	UNKWN	UNKWN	-	-	UNKWN	-	-	-	UNKWN	-	CAN COMM CIRCUIT (U1000)	-
HVAC	No indication	-	UNKWN	UNKWN	-	-	-	UNKWN	-	UNKWN	-	-	-	-
ALL MODE AWD/4WD	-	NG	UNKWN	UNKWN	UNKWN	-	UNKWN	-	-	UNKWN	-	-	CAN COMM CIRCUIT (U1000)	-
ABS	-	NG	UNKWN	UNKWN	UNKWN	UNKWN	-	-	UNKWN	-	-	-	CAN COMM CIRCUIT (U1000)	-
IPDM E/R	No indication	-	UNKWN	UNKWN	-	-	-	UNKWN	-	-	-	-	CAN COMM CIRCUIT (U1000)	-

PKIC3365E

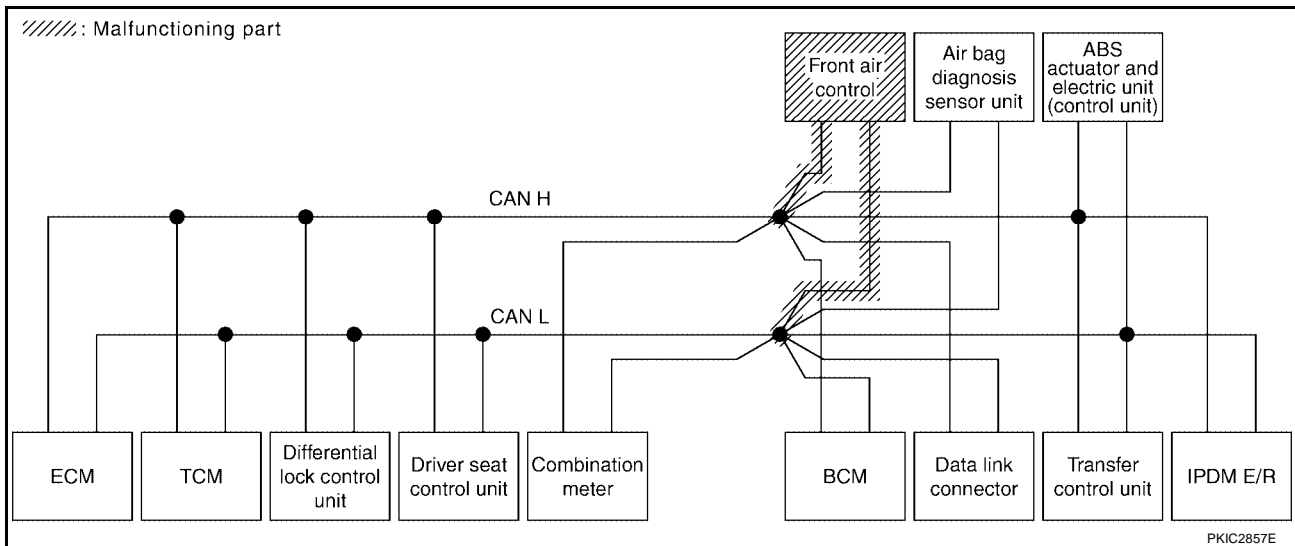

# CAN SYSTEM (TYPE 14)

[CAN]

## Case 8

Check BCM circuit. Refer to [LAN-359, "BCM Circuit Inspection"](#) .

SELECT SYSTEM screen		CAN DIAG SUPPORT MNTR											SELF-DIAG RESULTS		
		Initial diagnosis	Transmit diagnosis	Receive diagnosis											IPDM E/R
				ECM	TCM	DIFF LOCK	METER /M&A	BCM/SEC	STRG	AWD/4WD	VDC/TCS /ABS				
ENGINE	-	-	UNKWN	-	UNKWN	-	UNKWN	UN <del>✓</del> KN	-	UNKWN	UNKWN	UNKWN	CAN COMM CIRCUIT (U1000)	CAN COMM CIRCUIT (U1001) <del>UN</del> ✓	
A/T	-	NG	UNKWN	UNKWN	-	-	UNKWN	-	-	UNKWN	UNKWN	-	CAN COMM CIRCUIT (U1000)	-	
DIFF LOCK	-	NG	UNKWN	UNKWN	-	-	-	-	-	UNKWN	UNKWN	-	CAN COMM CIRCUIT (U1000)	-	
BCM	No <del>✓</del> indication	NG	UNKWN	UNKWN	-	-	UNKWN	-	-	-	-	UNKWN	CAN COMM CIRCUIT (U1000)	-	
HVAC	No indication	-	UNKWN	UNKWN	-	-	-	UN <del>✓</del> KN	-	-	-	UNKWN	-	-	
ALL MODE AWD/4WD	-	NG	UNKWN	UNKWN	UNKWN	-	UNKWN	-	-	-	-	UNKWN	CAN COMM CIRCUIT (U1000)	-	
ABS	-	NG	UNKWN	UNKWN	UNKWN	UNKWN	-	-	UNKWN	UNKWN	-	-	CAN COMM CIRCUIT (U1000)	-	
IPDM E/R	No indication	-	UNKWN	UNKWN	-	-	-	UN <del>✓</del> KN	-	-	-	-	CAN COMM CIRCUIT (U1000) <del>UN</del> ✓	-	

PKIC3398E

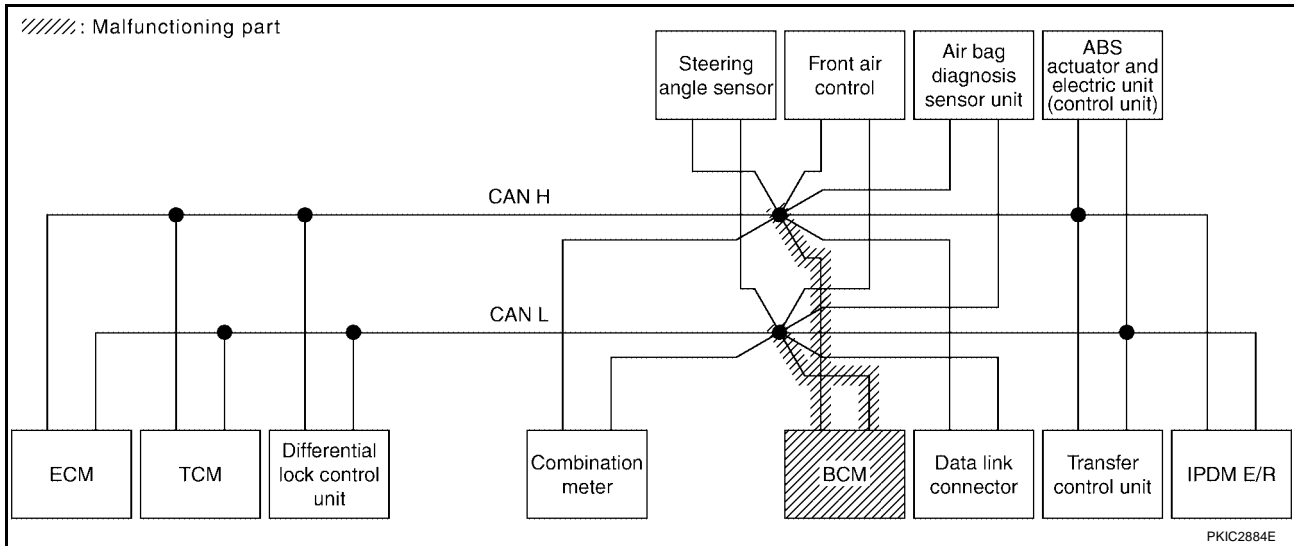

## Case 9

Check BCM circuit. Refer to [LAN-359, "BCM Circuit Inspection"](#) .

SELECT SYSTEM screen		CAN DIAG SUPPORT MNTR											SELF-DIAG RESULTS			
		Initial diagnosis	Transmit diagnosis	Receive diagnosis											IPDM E/R	
				ECM	TCM	METER /M&A	DISPLAY	BCM/SEC	STRG	HVAC	AWD/4WD	VDC/TCS /ABS				
ENGINE	-	-	UNKWN	-	UNKWN	UNKWN	-	UNKWN	✓	-	-	UNKWN	UNKWN	UNKWN	CAN COMM CIRCUIT (U1000)	CAN COMM CIRCUIT (U1001)
A/T	-	NG	UNKWN	UNKWN	-	UNKWN	-	-	-	-	-	UNKWN	UNKWN	-	CAN COMM CIRCUIT (U1000)	-
AUTO DRIVE POS.	No indication	-	-	-	UNKWN	UNKWN	-	UNKWN	✓	-	-	-	-	-	CAN COMM CIRCUIT (U1000)	-
Display control unit	-	NG	UNKWN	UNKWN	-	UNKWN	-	UNKWN	✓	-	UNKWN	-	-	UNKWN	-	-
BCM	No indication	NG	UNKWN	UNKWN	-	UNKWN	-	-	-	-	-	-	-	UNKWN	CAN COMM CIRCUIT (U1000)	-
HVAC	No indication	-	UNKWN	UNKWN	-	-	UNKWN	UNKWN	✓	-	-	-	UNKWN	-	-	-
ALL MODE AWD/4WD	-	NG	UNKWN	UNKWN	UNKWN	UNKWN	-	-	-	-	-	-	UNKWN	-	CAN COMM CIRCUIT (U1000)	-
ABS	-	NG	UNKWN	UNKWN	UNKWN	-	-	-	UNKWN	-	UNKWN	-	-	-	CAN COMM CIRCUIT (U1000)	-
IPDM E/R	No indication	-	UNKWN	UNKWN	-	-	-	UNKWN	✓	-	-	-	-	-	CAN COMM CIRCUIT (U1000)	-

PKIC3433E

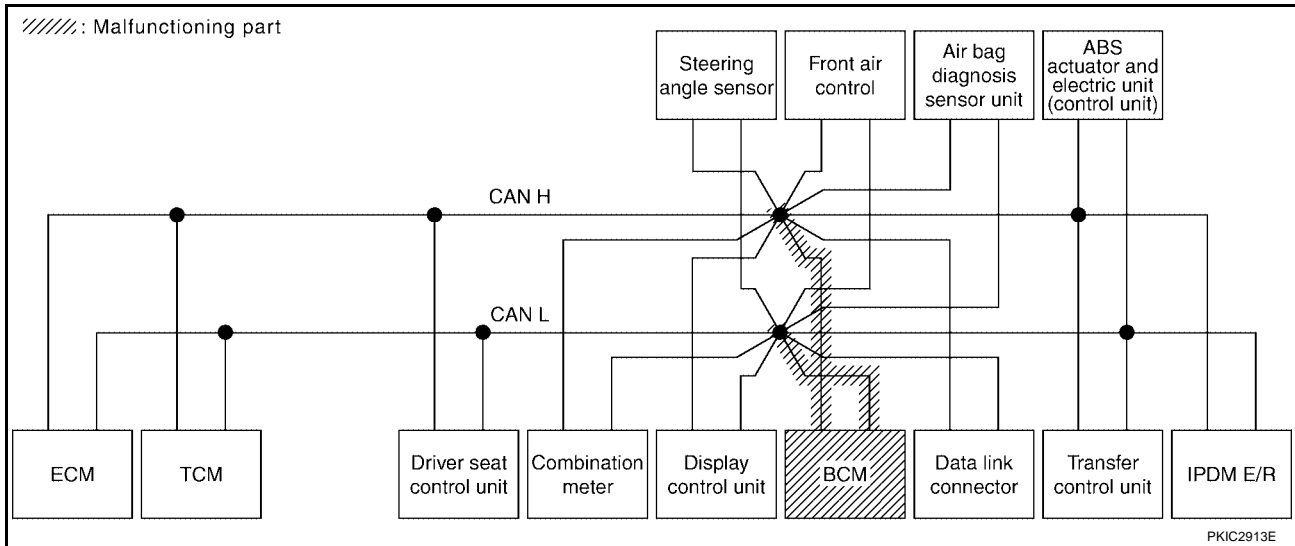

**3. CHECK HARNESS FOR OPEN CIRCUIT**

Check continuity between harness connector (A) and data link connector (B).

A		B		Continuity
Connector	Terminal	Connector	Terminal	
M40	51J	M22	6	Yes
	52J		14	Yes

OK or NG

- OK >> Connect all the connectors and diagnose again. Refer to [LAN-5, "TROUBLE DIAGNOSES WORK FLOW"](#).
- NG >> Repair harness.

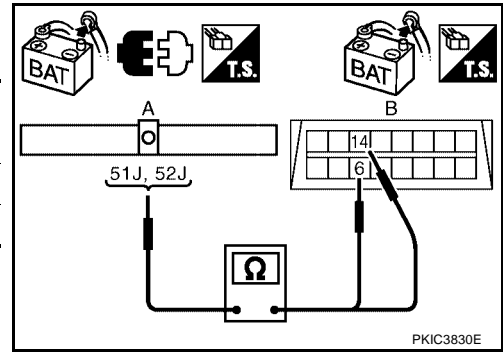

**Inspection Between Data Link Connector and ABS Actuator and Electric Unit (Control Unit) Circuit**

UKS004QA

**1. CHECK CONNECTOR**

1. Turn ignition switch OFF.
2. Disconnect the battery cable from the negative terminal.
3. Check following terminals and connectors for damage, bend and loose connection (connector side and harness side).
  - Harness connector M31
  - Harness connector E152

OK or NG

- OK >> GO TO 2.
- NG >> Repair terminal or connector.

**2. CHECK HARNESS FOR OPEN CIRCUIT**

1. Disconnect harness connector M31.
2. Check continuity between data link connector (A) and harness connector (B).

A		B		Continuity
Connector	Terminal	Connector	Terminal	
M22	6	M31	31G	Yes
	14		42G	Yes

OK or NG

- OK >> GO TO 3.
- NG >> Repair harness.

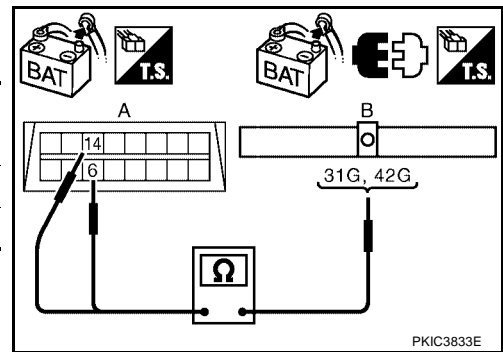

A  
B  
C  
D  
E  
F  
G  
H  
I  
J  
L  
M

LAN



# FRONT FOG LAMP

PF26150

## FRONT FOG LAMP

### Component Parts and Harness Connector Location

EKS00AAA

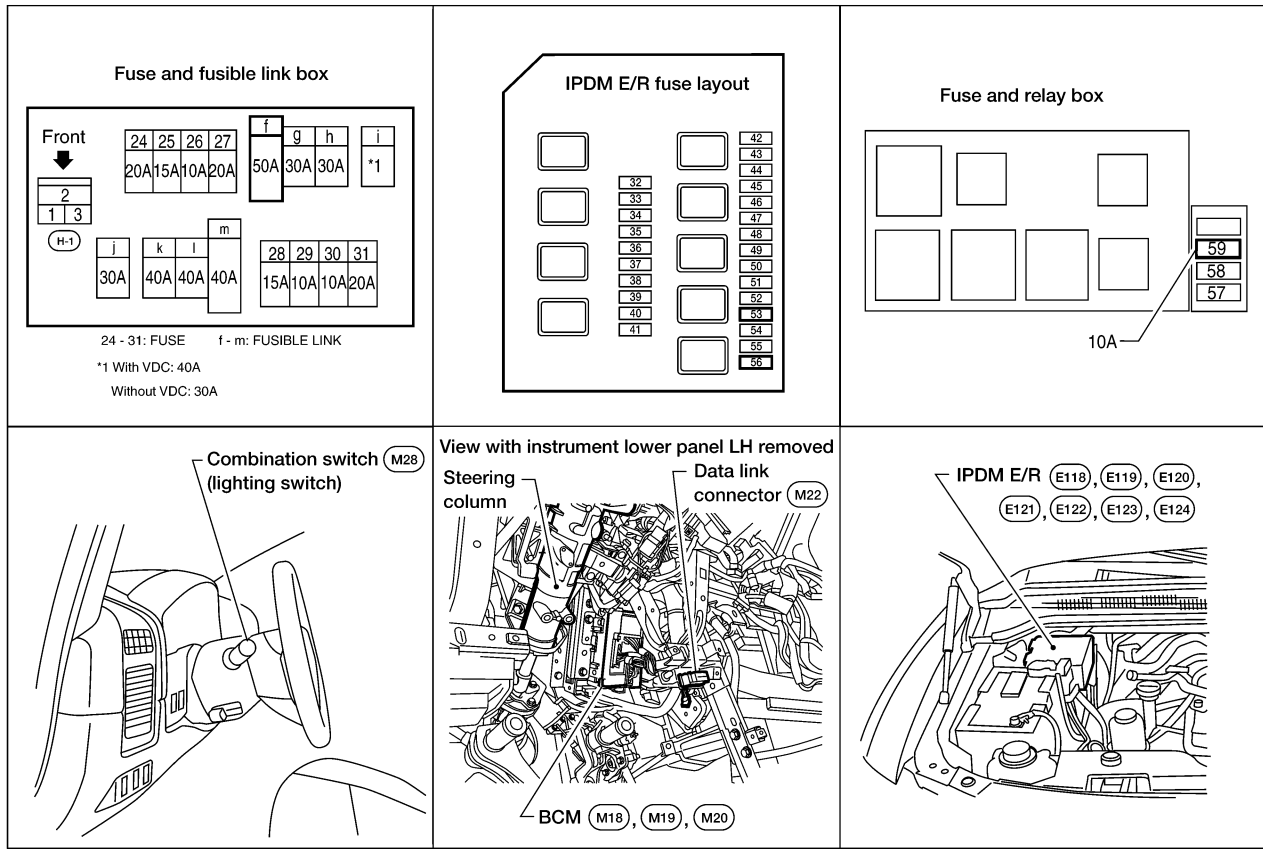

## System Description

EKS00AAB

Control of the fog lamps is dependent upon the position of the combination switch (lighting switch). The lighting switch must be in the 2ND position or AUTO position (LOW beam is ON) for front fog lamp operation. When the lighting switch is placed in the fog lamp position, the BCM (body control module) receives input signal requesting the fog lamps to illuminate. When the headlamps are illuminated, this input signal is communicated to the IPDM E/R (intelligent power distribution module engine room) across the CAN communication lines. The CPU (central processing unit) of the IPDM E/R controls the front fog lamp relay coil. When activated, this relay directs power to the front fog lamps.

## OUTLINE

Power is supplied at all times

- to ignition relay, located in the IPDM E/R, and
- to front fog lamp relay, located in the IPDM E/R, and
- through 20A fuse (No. 53, located in the IPDM E/R)
- to CPU of the IPDM E/R, and
- through 50A fusible link (letter f, located in the fuse and fusible link box)
- to BCM terminal 70.

When the ignition switch is in ON or START position, power is supplied

- to ignition relay, located in the IPDM E/R, and
- through 10A fuse (No. 59, located in the fuse and relay box)
- to BCM terminal 38.

Ground is supplied

- to BCM terminal 67
- through grounds M57, M61 and M79, and
- to IPDM E/R terminals 38 and 59

A  
B  
C  
D  
E  
F  
G  
H  
I  
J  
LT  
L  
M

# STOP LAMP

---

## STOP LAMP

PF2:26550

### System Description

EKS00ABC

Power is supplied at all times

- through 10A fuse [No. 20, located in fuse block (J/B)]
- to stop lamp switch terminal 1 and
- to stop lamp relay terminal 1 (with VDC).

When the brake pedal is pressed, the stop lamp switch is closed and power is supplied

- through stop lamp switch terminal 2
- to stop lamp relay terminal 3 (with VDC)
- through stop lamp relay terminal 4 (with VDC)
- to rear combination lamp LH and RH terminal 7, and
- to high-mounted stop lamp terminal 1.

Ground is supplied

- to rear combination lamp LH and RH terminal 5
- through grounds E9, E15 and E24, and
- to high-mounted stop lamp terminal 2
- through grounds B117 and B132.

With power and ground supplied, the stop lamps illuminate.

# INTERIOR ROOM LAMP

## Wiring Diagram — INT/L —

EKS00AC6

LT-INT/L-01

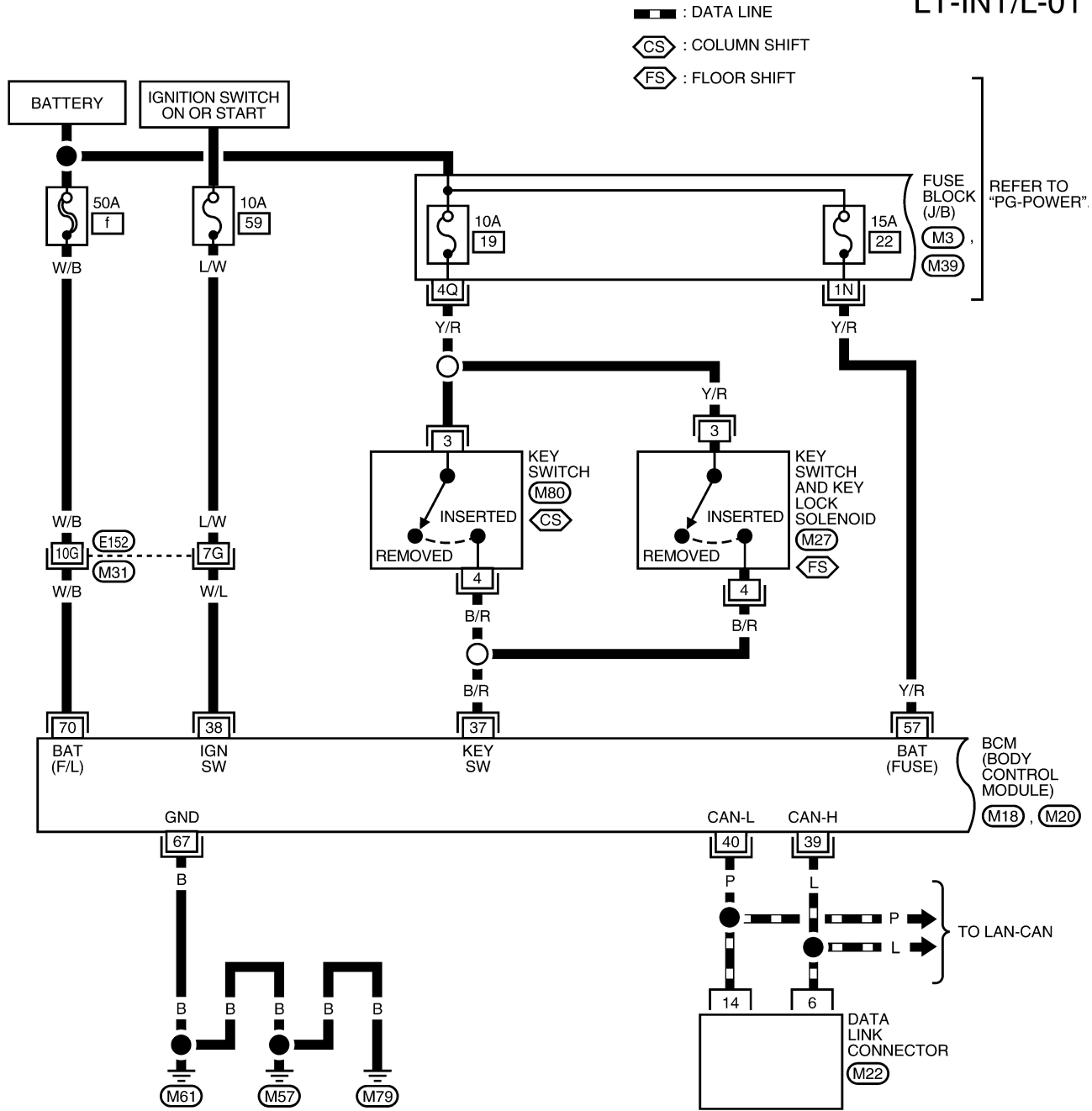

A  
B  
C  
D  
E  
F  
G  
H  
I  
J  
LT  
L  
M

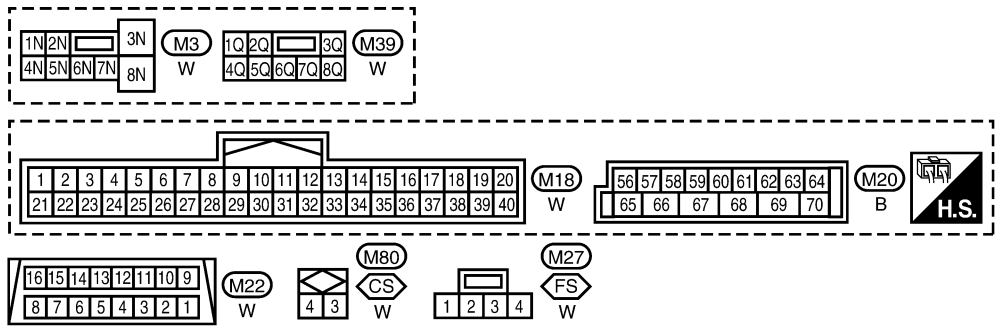

REFER TO THE FOLLOWING.  
 (M31) - SUPER MULTIPLE JUNCTION (SMJ)

WKWA2448E

# PREPARATION

## Commercial Service Tool

EBS00R16

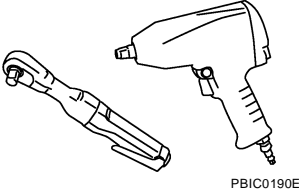
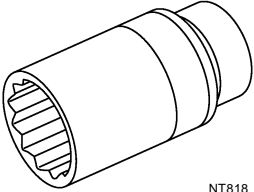
Tool name	Description
<p data-bbox="164 245 272 273">Power tool</p>  <p data-bbox="852 447 922 464">PBIC0190E</p>	<p data-bbox="1013 245 1268 273">Loosening bolts and nuts</p>
<p data-bbox="164 480 289 508">Deep socket</p>  <p data-bbox="852 699 898 716">NT818</p>	<p data-bbox="1013 480 1446 537">Removing and installing oil pressure switch Deep socket 26 mm</p>

# CHASSIS AND BODY MAINTENANCE

## FILLING

1. Remove the filler plug and gasket.
2. Fill with new specified fluid until the fluid level reaches the specified limit near the filler plug mounting hole as shown.

**Fluid grade and capacity** : Refer to [MA-11, "Fluids and Lubricants"](#) .

### CAUTION:

Carefully fill the transfer with fluid. Filling should take approximately three minutes.

3. Leave the vehicle for three minutes and then check the fluid level again as shown.
4. Install the new gasket on the filler plug and install the filler plug in the transfer. Tighten the filler plug to specification.

**Filler plug** : Refer to [TF-96, "COMPONENTS"](#) .

### CAUTION:

Do not reuse the gasket.

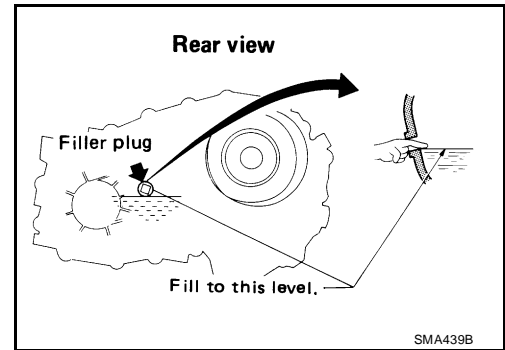

## Checking Transfer Fluid FLUID LEAKAGE AND FLUID LEVEL

ELS001H8

1. Check for any fluid leaks from the transfer assembly or around it and correct as necessary.
2. Remove the filler plug to check the fluid level at the filler plug mounting hole as shown.

### CAUTION:

Do not start the engine while checking the fluid level.

3. Install the new gasket on the filler plug and install the filler plug in the transfer. Tighten the filler plug to specification.

**Filler plug** : Refer to [TF-96, "COMPONENTS"](#) .

### CAUTION:

Do not reuse the gasket.

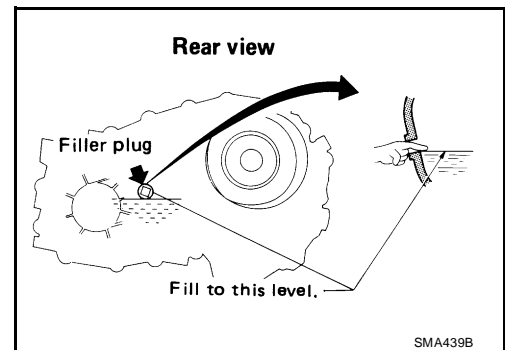

## Checking Propeller Shaft

ELS001A0

Check the front and rear propeller shafts for damage, dents, and cracks. Check the joints for looseness and any damage. Repair or replace as necessary.

## Checking Final Drive Oil

ELS001A1

### NOTE:

Rear final drive shown, front final drive similar.

## OIL LEAKAGE AND OIL LEVEL

1. Check that gear oil is not leaking from the final drive assembly or around it.
2. Check the gear oil level from filler plug mounting hole as shown.

### CAUTION:

Do not start engine while checking oil level.

3. Apply sealant to the filler plug. Install the filler plug on the final drive assembly and tighten to specification.

- Use Genuine Silicone RTV or equivalent. Refer to [GI-45, "Recommended Chemical Products and Sealants"](#) .

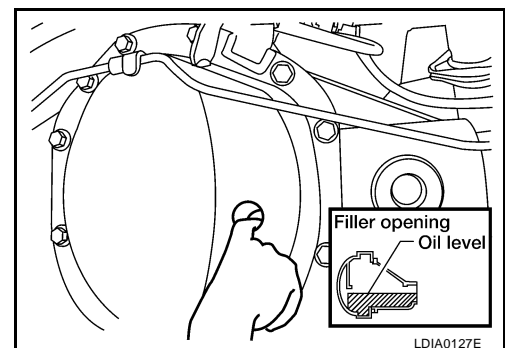

A  
B  
C  
D  
E  
F  
G  
H  
I  
J  
K  
MA  
M

# TROUBLE DIAGNOSIS

## SELF-DIAGNOSIS

### Operation Procedure

1. Touch "SELF-DIAG RESULTS" on "SELECT DIAG MODE" screen to view all set DTC's.

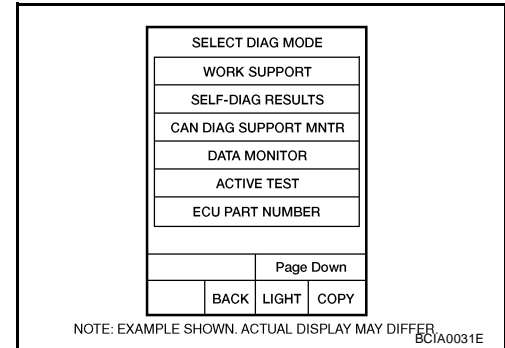

### Display Item List

DTC	Description	Reference page
B2573	Battery voltage out of range	<a href="#">SC-4, "BATTERY"</a>
B2581	Intake sensor circuit short	<a href="#">MTC-61, "Intake Door Motor Circuit"</a>
B2582	Intake sensor circuit open	
U1000	CAN bus fault	<a href="#">LAN-25, "CAN COMMUNICATION"</a>
B2587	Stuck button	<a href="#">MTC-95, "CONTROL UNIT"</a>

## DATA MONITOR

### Operation Procedure

1. Touch "DATA MONITOR" on "SELECT DIAG MODE" screen.

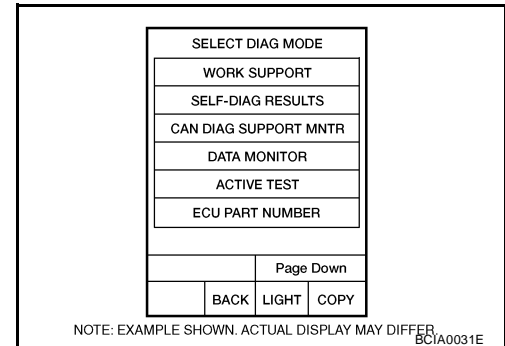

2. Touch either "MAIN SIGNALS" or "SELECTION FROM MENU" on "DATA MONITOR" screen.

MAIN SIGNALS	Monitors all the items.
SELECTION FROM MENU	Selects and monitors the individual item selected.

3. When "SELECTION FROM MENU" is selected, touch items to be monitored. When "MAIN SIGNALS" is selected, all the items will be monitored.
4. Touch "START".
5. Touch "RECORD" while monitoring, then the status of the monitored item can be recorded. To stop recording, touch "STOP".

### Display Item List

Monitor item	Value	Contents
BATT VIA CAN	"V"	Displays battery voltage signal.
IGN VIA CAN	"ON/OFF"	Displays ignition switch signal.
EVAP TEMP SEN	"°C/°F"	Displays intake sensor signal.

# TROUBLE DIAGNOSIS

## 2. CHECK DEFROSTER DOOR MOTOR CIRCUITS FOR SHORT TO GROUND

1. Turn ignition switch OFF.
2. Disconnect the front air control harness connector.
3. Check continuity between front air control harness connector M49 terminal 19, 20 and ground.

**19 - Ground : Continuity should not exist.**  
**20 - Ground : Continuity should not exist.**

OK or NG

OK >> Replace front air control. Refer to [MTC-95, "REMOVAL"](#)

NG >> Repair or replace harness as necessary.

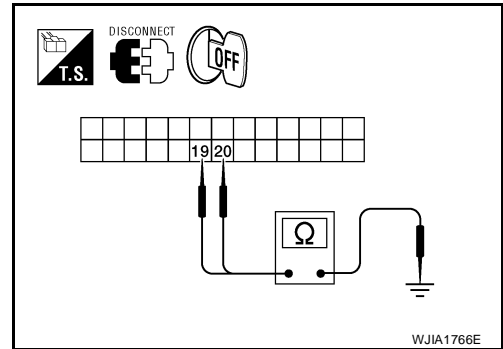

## 3. CHECK FRONT AIR CONTROL FOR GROUND AND POWER

1. Press the defroster switch (☞).
2. Check voltage between front air control harness connector M49 terminal 19 and terminal 20 and press the defroster switch (☞) again.

Connector	Terminals		Condition	Voltage (Approx.)
	(+)	(-)		
Front air control: M49	19	20	Press defroster switch	Battery voltage

OK or NG

OK >> GO TO 4.

NG >> Replace front air control. Refer to [MTC-95, "REMOVAL"](#).

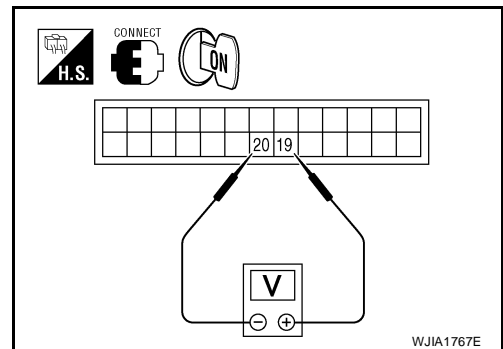

## 4. CHECK DEFROSTER DOOR MOTOR AND CIRCUITS FOR OPEN

1. Turn ignition switch OFF.
2. Disconnect the front air control harness connector.
3. Check continuity between front air control harness connector M49 terminal 19 and terminal 20.

**Continuity should exist.**

OK or NG6

OK >> GO TO 6.

NG >> GO TO 5.

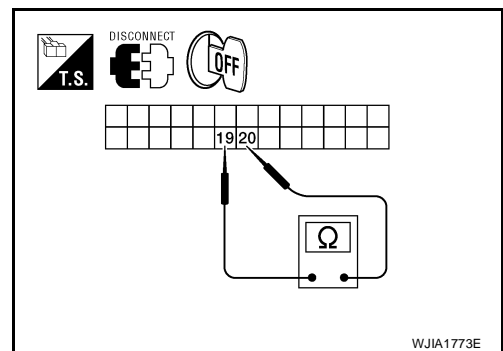

## 5. CHECK DEFROSTER DOOR MOTOR CIRCUITS FOR OPEN

1. Disconnect the defroster door motor harness connector.
2. Check continuity between front air control harness connector M49 terminal 19, 20 and the defroster door motor harness connector terminal 1, 6.

**19 - 1 : Continuity should exist.**  
**20 - 6 : Continuity should exist.**

OK or NG

OK >> Replace defroster door motor. Refer to [MTC-104, "DEFROSTER DOOR MOTOR"](#).

NG >> Repair or replace harness as necessary.

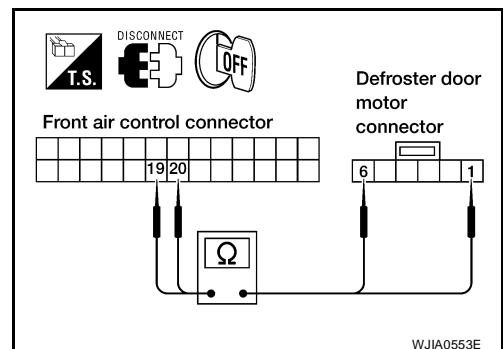

A  
B  
C  
D  
E  
F  
G  
H  
I  
K  
L  
M

MTC

# DEFROSTER DOOR MOTOR

## DEFROSTER DOOR MOTOR

PF2:27733

### Removal and Installation

EJS00331

#### Defroster Door Motor - Heater and Cooling Unit Assembly

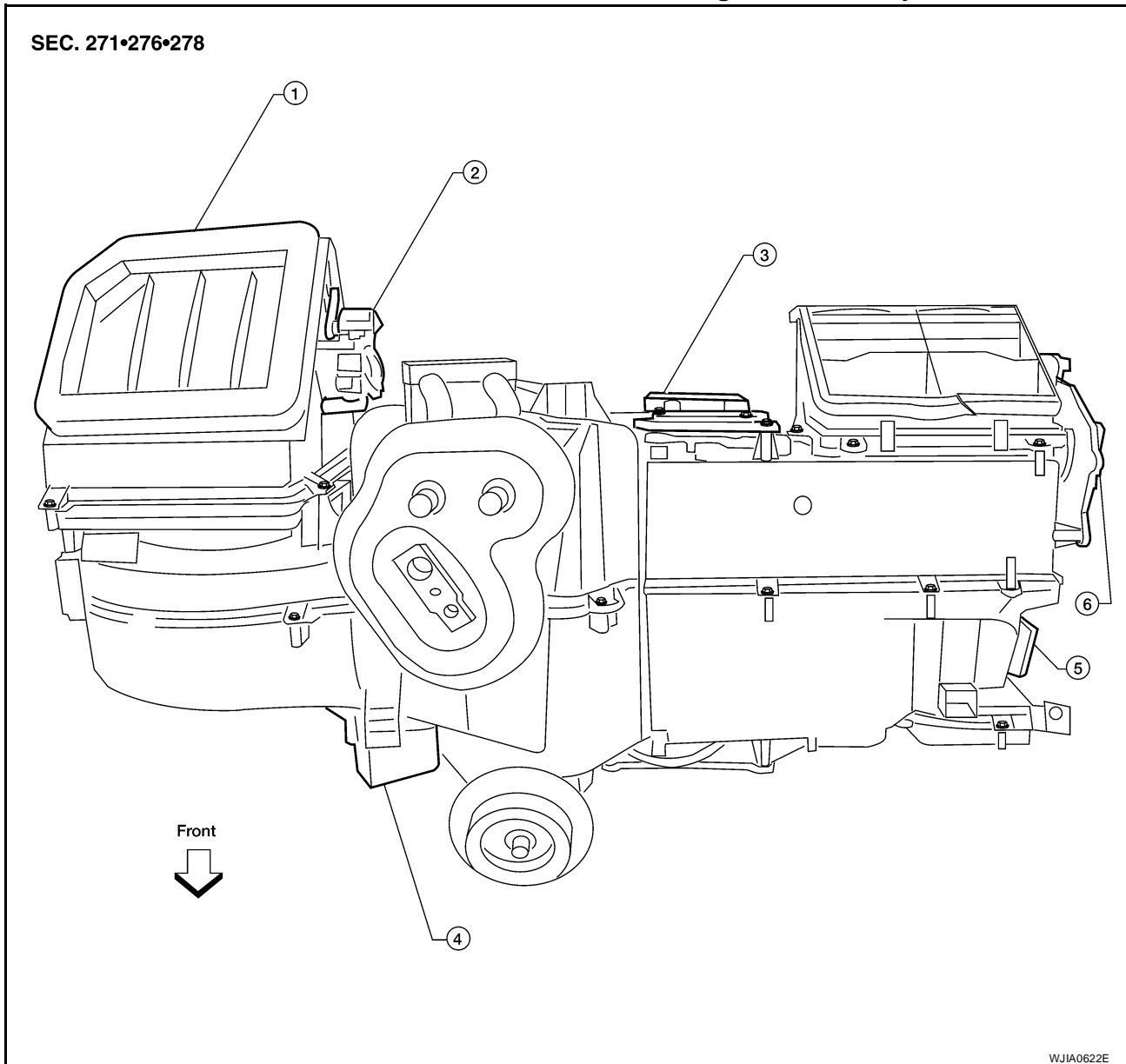

- |                                     |                      |                         |
|-------------------------------------|----------------------|-------------------------|
| 1. Heater and cooling unit assembly | 2. Intake door motor | 3. Air mix door motor   |
| 4. Variable blower control          | 5. Mode door motor   | 6. Defroster door motor |

### REMOVAL

1. Remove the BCM. Refer to [BCS-20, "BCM"](#).
2. Remove the audio amplifier, if equipped. Refer to [AV-74, "AUDIO AMP."](#)
3. Disconnect the defroster door motor electrical connector.
4. Remove the three screws and remove the defroster door motor.

### INSTALLATION

Installation is in the reverse order of removal.

# PRECAUTIONS

## PRECAUTIONS

PFP:00011

### Precautions for Supplemental Restraint System (SRS) “AIR BAG” and “SEAT BELT PRE-TENSIONER”

EKS00AR4

The Supplemental Restraint System such as “AIR BAG” and “SEAT BELT PRE-TENSIONER”, used along with a front seat belt, helps to reduce the risk or severity of injury to the driver and front passenger for certain types of collision. This system includes seat belt switch inputs and dual stage front air bag modules. The SRS system uses the seat belt switches to determine the front air bag deployment, and may only deploy one front air bag, depending on the severity of a collision and whether the front occupants are belted or unbelted. Information necessary to service the system safely is included in the SRS and SB section of this Service Manual.

#### **WARNING:**

- To avoid rendering the SRS inoperative, which could increase the risk of personal injury or death in the event of a collision which would result in air bag inflation, all maintenance must be performed by an authorized NISSAN/INFINITI dealer.
- Improper maintenance, including incorrect removal and installation of the SRS, can lead to personal injury caused by unintentional activation of the system. For removal of Spiral Cable and Air Bag Module, see the SRS section.
- Do not use electrical test equipment on any circuit related to the SRS unless instructed to in this Service Manual. SRS wiring harnesses can be identified by yellow and/or orange harnesses or harness connectors.

A

B

C

D

E

F

G

H

I

J

PG

L

M

# GROUND CIRCUIT

## BODY NO. 2 HARNESS

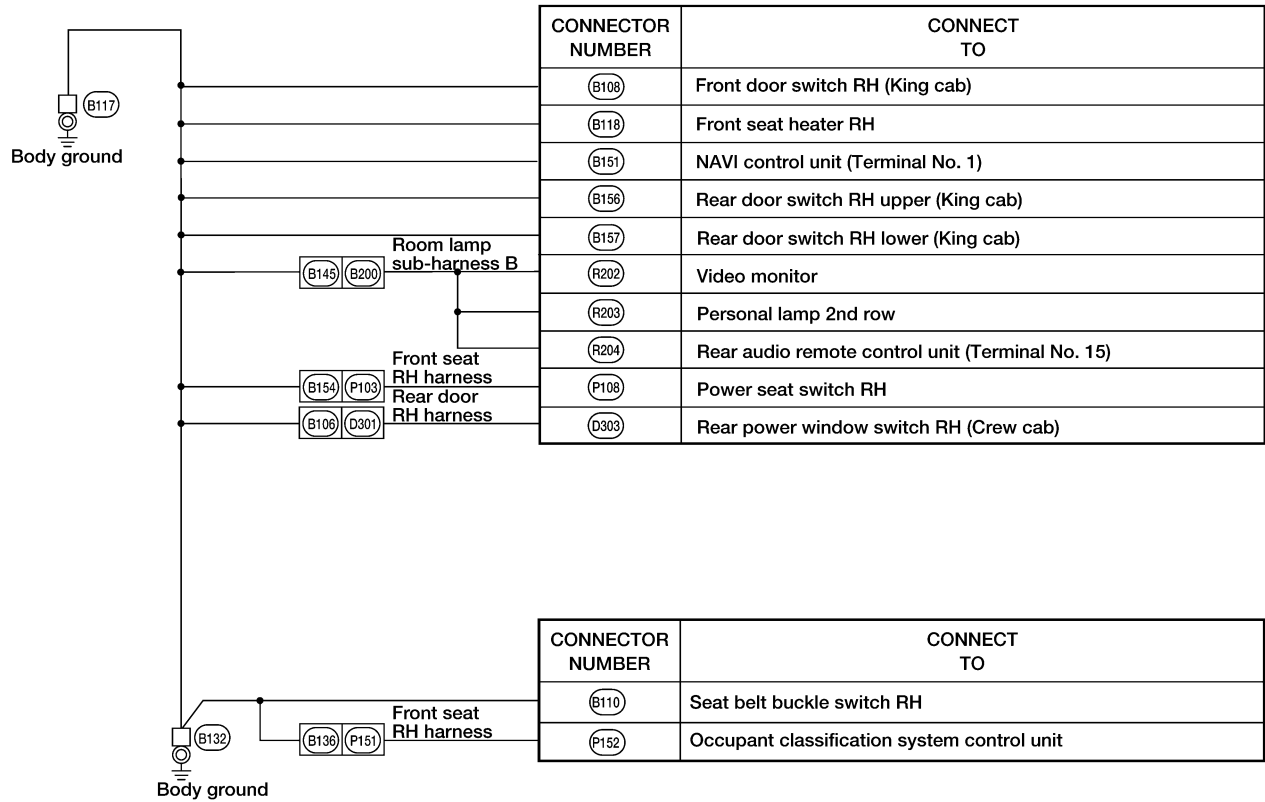
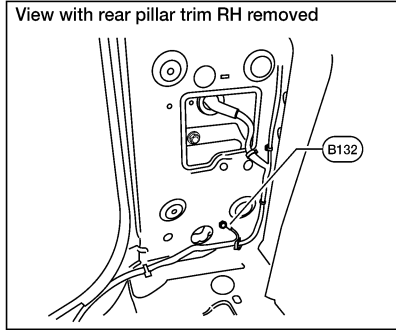
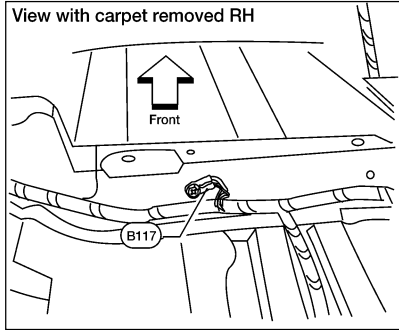

WKIA4704E

# STANDARDIZED RELAY

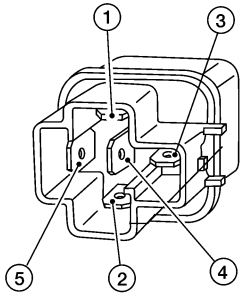
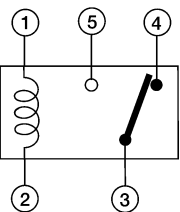
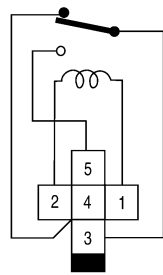
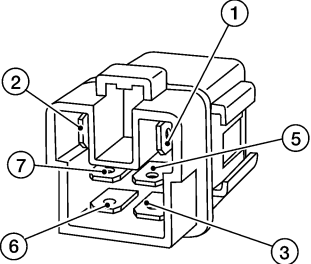
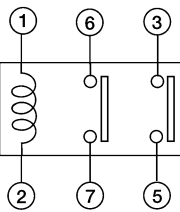
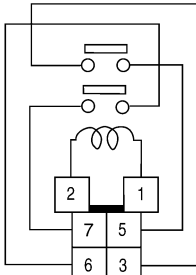
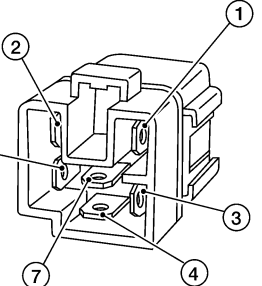
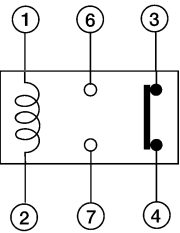
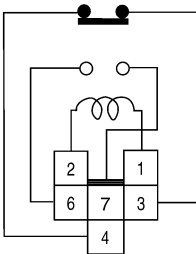
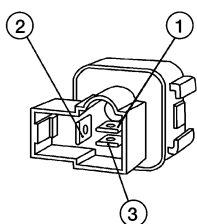
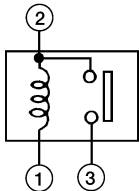
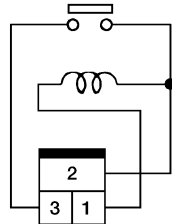
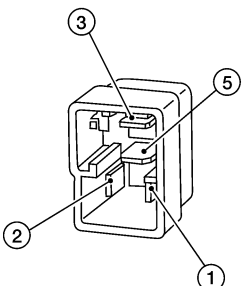
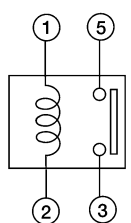
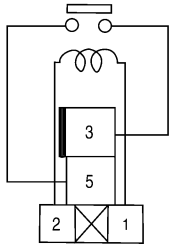
Type	Outer view	Circuit	Connector Symbol and connection	Case color
1T				BLACK
2M				BROWN
1M-1B				GRAY
1M				BLACK
				BLUE

The arrangement of terminal numbers on the actual relays may differ from those shown above.

WKIA0253E

A  
B  
C  
D  
E  
F  
G  
H  
I  
J  
PG  
L  
M

# POWER STEERING GEAR AND LINKAGE

## POWER STEERING GEAR AND LINKAGE

PFP:49001

### Removal and Installation

EGS00074

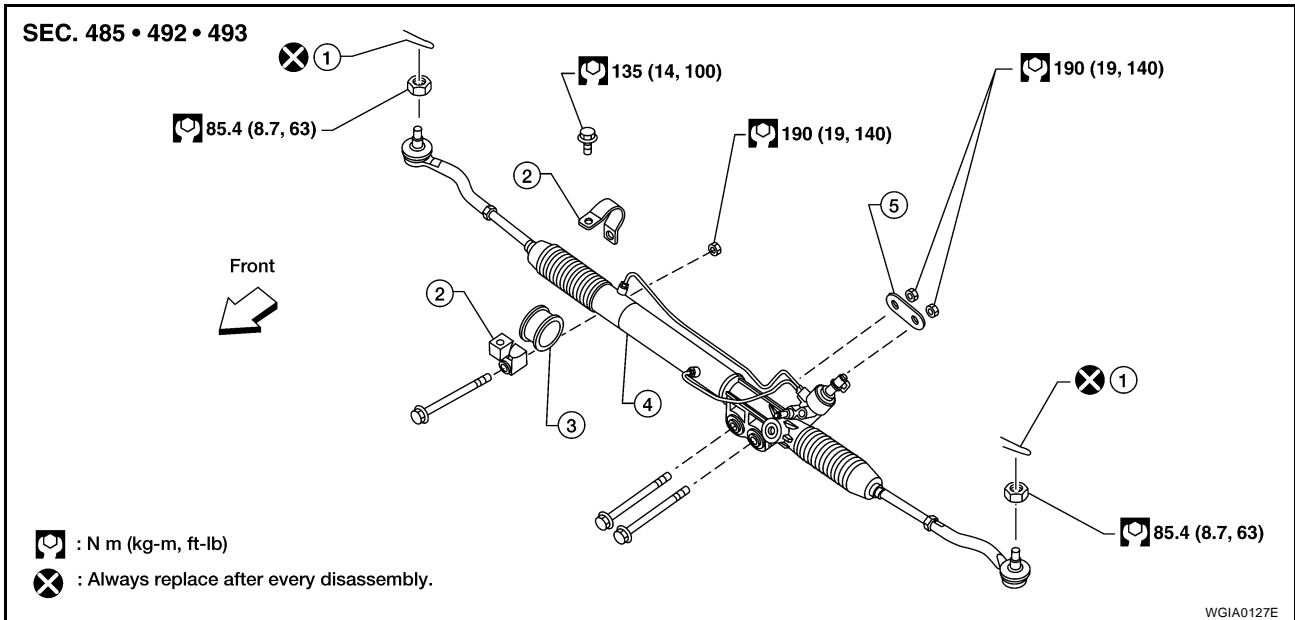

- |                           |                     |                       |
|---------------------------|---------------------|-----------------------|
| 1. Cotter pin             | 2. Mounting bracket | 3. Mounting insulator |
| 4. Steering gear assembly | 5. Washer           |                       |

#### CAUTION:

Spiral cable may snap due to steering operation if steering column is separated from steering gear assembly. Therefore secure steering wheel to avoid turning.

#### REMOVAL

1. Turn wheels to the straight-ahead position.
2. Remove wheel and tire from vehicle using power tool.
3. Remove undercover using power tool.
4. On 4WD model, remove front final drive, then support drive shafts with wire. Refer to [FAX-7, "Removal and Installation"](#).
5. Remove cotter pin at steering outer socket and discard, then loosen nut.
6. Remove steering outer socket from steering knuckle using Tool. Be careful not to damage ball joint boot.

#### CAUTION:

Temporarily tighten nut to prevent damage to threads and to prevent Tool from coming off.

Tool number : HT72520000 (J-25730-A)

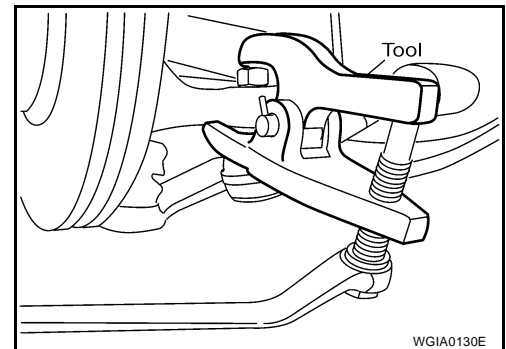

7. On 2WD model, remove stabilizer bar bolts and reposition stabilizer bar. Refer to [FSU-12, "STABILIZER BAR"](#).

# SUNROOF

## Wiring Diagram — SROOF —

EIS004DS

### RF-SROOF-01

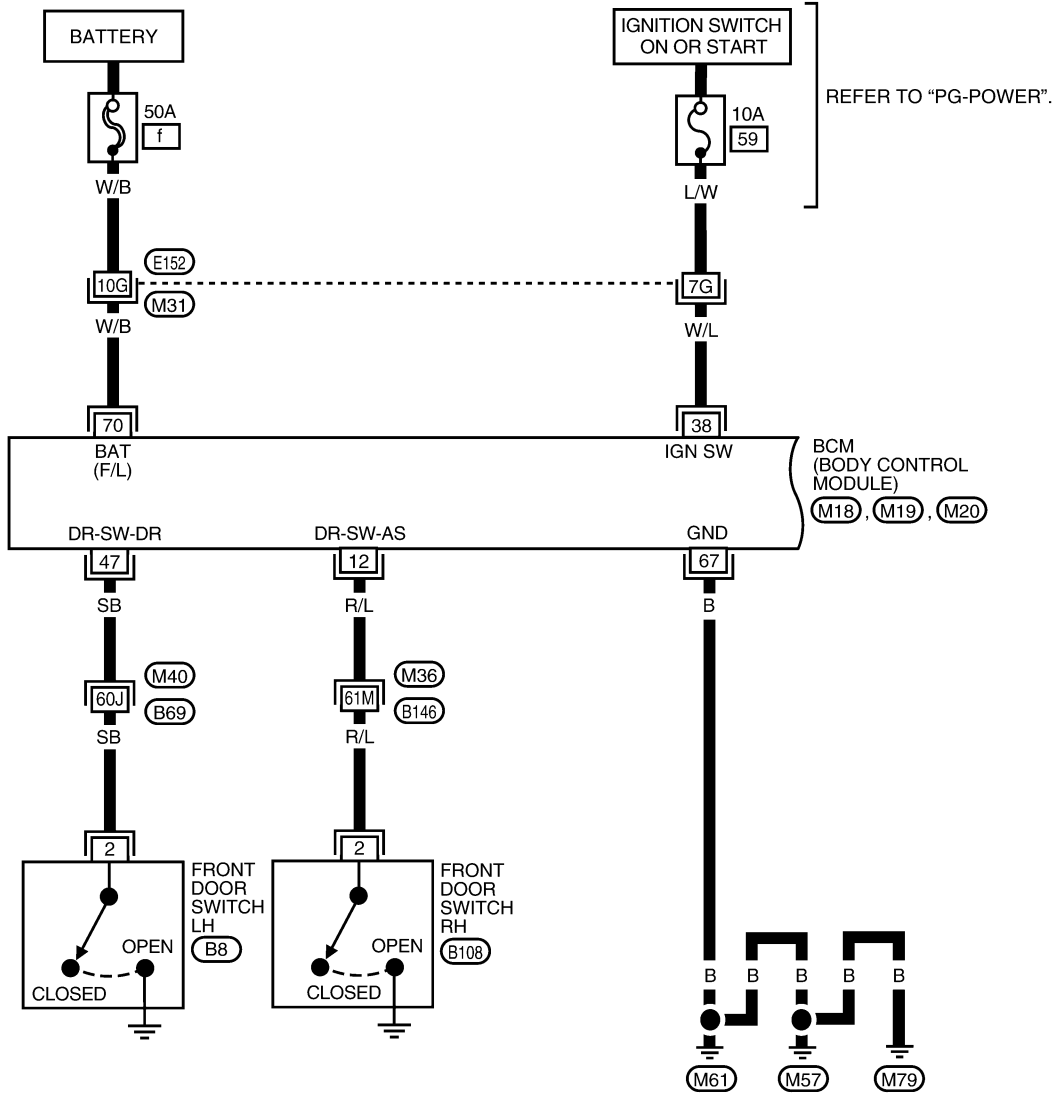

A  
B  
C  
D  
E  
F  
G  
H  
RF  
J  
K  
L  
M

1	2	3	4	5	6	7	8	9	10	11	12	13	14	15	16	17	18	19	20
21	22	23	24	25	26	27	28	29	30	31	32	33	34	35	36	37	38	39	40

M18 W

41	42	43	44	45	46	47	48	49
50	51	52	53	54	55			

M19 W

56	57	58	59	60	61	62	63	64
65	66	67	68	69	70			

M20 B



1
2
3

B8, B108  
W W

REFER TO THE FOLLOWING.  
M31, M36, M40  
- SUPER MULTIPLE JUNCTION (SMJ)

WIWA1392E

## REAR FINAL DRIVE ASSEMBLY [WITHOUT ELECTRONIC LOCKING DIFFERENTIAL]

- Keep side bearing outer races together with inner races. Do not mix them up. Also, keep side bearing adjusters together with bearing.
- Remove side bearing adjusters from gear carrier.

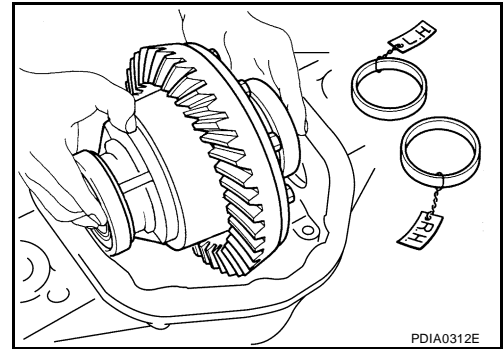

- Remove side bearing inner races using suitable puller.

**CAUTION:**  
Do not damage differential case.

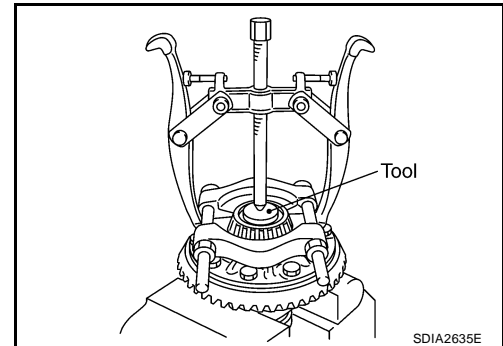

- For proper reinstallation, paint matching mark on differential case and drive gear.

**CAUTION:**  
Use paint for matching marks. Do not damage differential case or drive gear.

- Remove drive gear bolts.
- Tap the drive gear off the differential case using suitable tool.

**CAUTION:**  
Tap evenly all around to keep drive gear from binding.

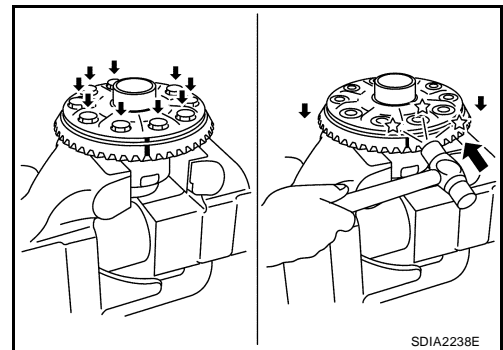

- Remove the lock pin of the pinion mate shaft from the drive gear side using Tool.

**Tool number** : ST23550000 ( — )

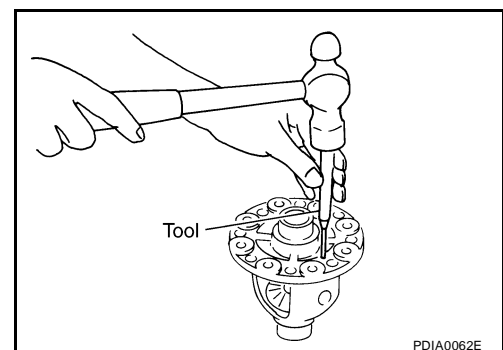

- Remove the pinion mate shaft.

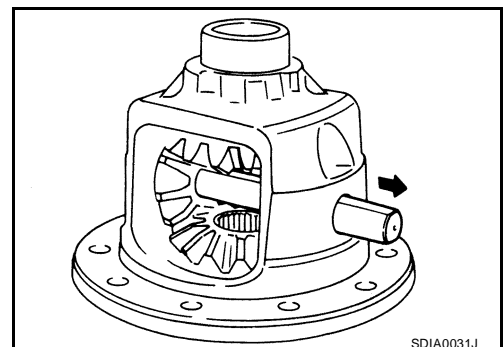

# TROUBLE DIAGNOSIS FOR SYSTEM [WITH ELECTRONIC LOCKING DIFFERENTIAL]

## DIAGNOSTIC PROCEDURE

### 1. CHECK DIFFERENTIAL LOCK MODE SWITCH SIGNAL

④ With CONSULT-II

1. Start engine.
2. Select "DATA MONITOR" mode for "DIFF LOCK" with CONSULT-II.
3. Read out ON/OFF switching action of "D-LOCK SW SIG".

Monitor item	Condition		Display value
D-LOCK SW SIG	<ul style="list-style-type: none"> <li>● Vehicle stopped</li> <li>● Engine running</li> </ul>	Differential lock mode switch: ON	ON
		Differential lock mode switch: OFF	OFF

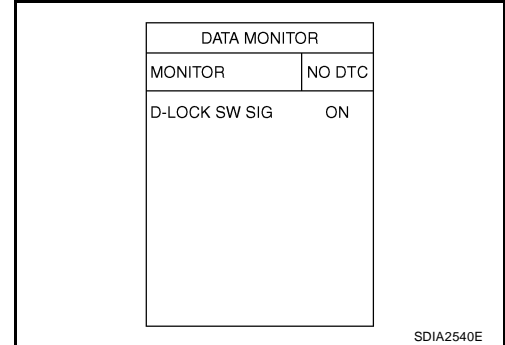

⊗ Without CONSULT-II

1. Turn ignition switch "ON".
2. Check voltage between differential lock control unit harness connector terminals and ground.

Connector	Terminal	Condition	Voltage (Approx.)
B77	9 - Ground	Differential lock mode switch: ON	Battery voltage
		Differential lock mode switch: OFF	0V
	22 - Ground	Differential lock mode switch: ON	0V
		Differential lock mode switch: OFF	Battery voltage

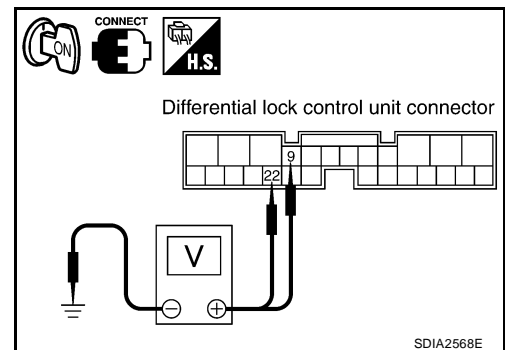

**OK or NG**

- OK >> GO TO 5.  
NG >> GO TO 2.

# REAR FINAL DRIVE ASSEMBLY [WITH ELECTRONIC LOCKING DIFFERENTIAL]

OLD DRIVE PINION MARKING	NEW DRIVE PINION MARKING mm (in)								
	-10 (-4)	-8 (-3)	-5 (-2)	-3 (-1)	0 (0)	+3 (+1)	+5 (+2)	+8 (+3)	+10 (+4)
+10 (+4)	+0.20 (+0.008)	+0.18 (+0.007)	+0.15 (+0.006)	+0.13 (+0.005)	+0.10 (+0.004)	+0.08 (+0.003)	+0.05 (+0.002)	+0.02 (+0.001)	0 (0)
+8 (+3)	+0.18 (+0.007)	+0.15 (+0.006)	+0.13 (+0.005)	+0.10 (+0.004)	+0.08 (+0.003)	+0.05 (+0.002)	+0.02 (+0.001)	0 (0)	-0.02 (-0.001)
+5 (+2)	+0.15 (+0.006)	+0.13 (+0.005)	+0.10 (+0.004)	+0.08 (+0.003)	+0.05 (+0.002)	+0.02 (+0.001)	0 (0)	-0.02 (-0.001)	-0.05 (-0.002)
+3 (+1)	+0.13 (+0.005)	+0.10 (+0.004)	+0.08 (+0.003)	+0.05 (+0.002)	+0.02 (+0.001)	0 (0)	-0.02 (-0.001)	-0.05 (-0.002)	-0.08 (-0.003)
0 (0)	+0.10 (+0.004)	+0.08 (+0.003)	+0.05 (+0.002)	+0.02 (+0.001)	0 (0)	-0.02 (-0.001)	-0.05 (-0.002)	-0.08 (-0.003)	-0.10 (-0.004)
-3 (-1)	+0.08 (+0.003)	+0.05 (+0.002)	+0.02 (+0.001)	0 (0)	-0.02 (-0.001)	-0.05 (-0.002)	-0.08 (-0.003)	-0.10 (-0.004)	-0.13 (-0.005)
-5 (-2)	+0.05 (+0.002)	+0.02 (+0.001)	0 (0)	-0.02 (-0.001)	-0.05 (-0.002)	-0.08 (-0.003)	-0.10 (-0.004)	-0.13 (-0.005)	-0.15 (-0.006)
-8 (-3)	+0.02 (+0.001)	0 (0)	-0.02 (-0.001)	-0.05 (-0.002)	-0.08 (-0.003)	-0.10 (-0.004)	-0.13 (-0.005)	-0.15 (-0.006)	-0.18 (-0.007)
-10 (-4)	0 (0)	-0.02 (-0.001)	-0.05 (-0.002)	-0.08 (-0.003)	-0.10 (-0.004)	-0.13 (-0.005)	-0.15 (-0.006)	-0.18 (-0.007)	-0.20 (-0.008)

1. Make sure all parts are clean and that drive pinion bearings are well lubricated.
2. Assemble drive pinion bearings into the tools.

**Tool number**      **A:** —      **(8144)**  
                                 **B:** —      **(6740)**  
                                 **C:** —      **(6741)**

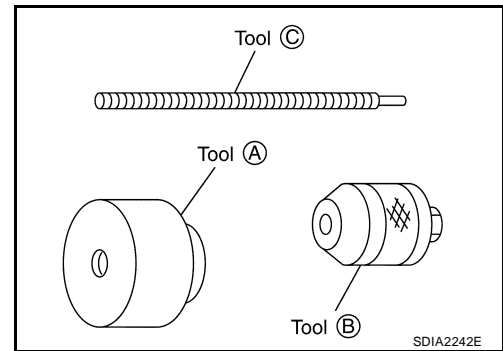

3. Install drive pinion bearing inner race and drive pinion height adjusting washer to gear carrier using tool as shown.

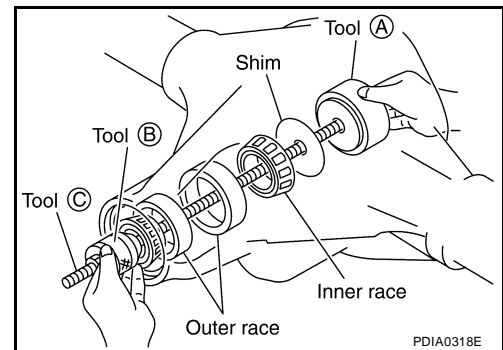

4. Turn the assembly several times to seat drive pinion bearings.

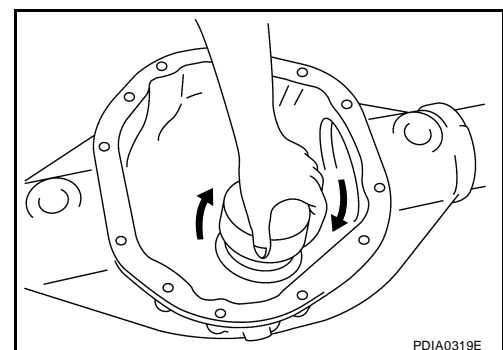

# PREPARATION

## PREPARATION

PFP:00002

### Special Service Tool

EKS00A8B

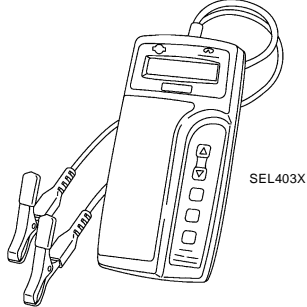
Tool number (Kent-Moore No.) Tool name	Description
<p>— (J-44373) Battery/Starting/Charging system tester</p>  <p style="text-align: right;">SEL403X</p>	<p>Tests battery, starting and charging system.</p>

### Commercial Service Tools

EKS00A8C

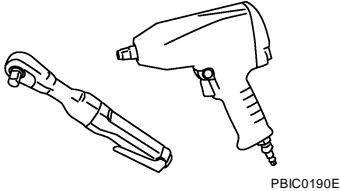
Tool name	Description
<p>Power tool</p>  <p style="text-align: right;">PBIC0190E</p>	<p>Loosening bolts and nuts</p>

A  
B  
C  
D  
E  
F  
G  
H  
I  
J  
L  
M

SC

# AUTOMATIC DRIVE POSITIONER

## Schematic

EIS004FG

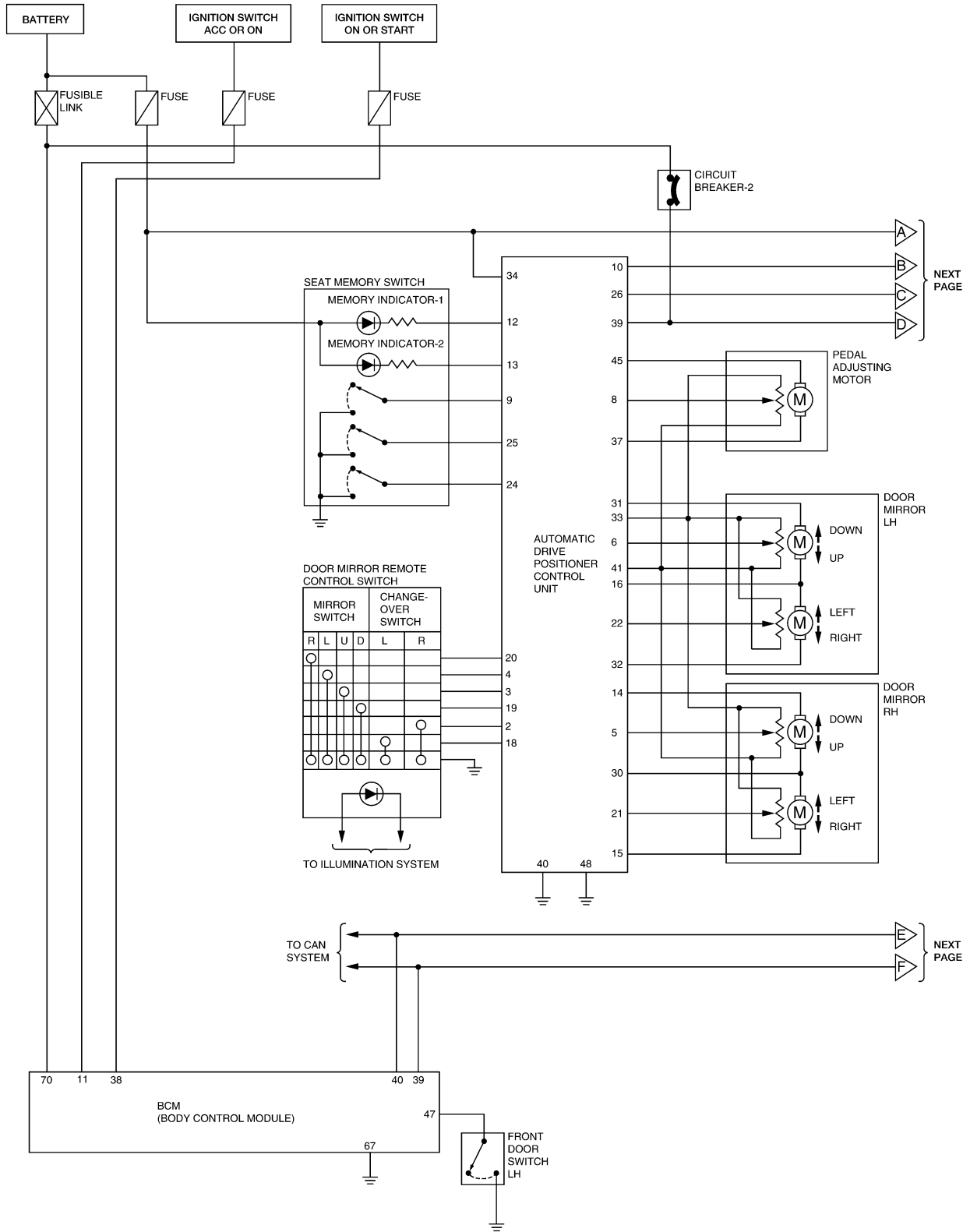

WIWA1364E

# AUTOMATIC DRIVE POSITIONER

## 2. CHECK RECLINING MOTOR SENSOR CIRCUIT HARNESS CONTINUITY

1. Disconnect driver seat control unit and reclining motor LH.
2. Check continuity between driver seat control unit connector P2 terminals 9, 31 and reclining motor LH connector P5 terminals 1, 2.

**9 - 1** : Continuity should exist.

**31 - 2** : Continuity should exist.

3. Check continuity between driver seat control unit connector P2 terminals 9, 31 and ground.

**9 - Ground** : Continuity should not exist.

**31 - Ground** : Continuity should not exist.

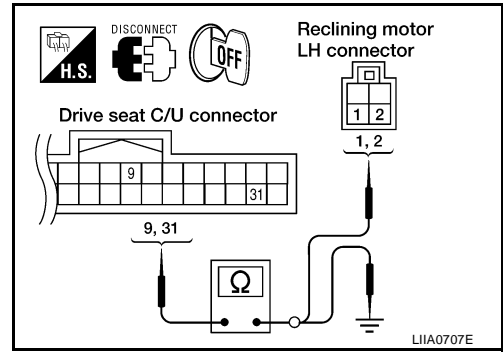

OK or NG

- OK >> Replace reclining motor LH. Refer to [SE-88, "FRONT SEAT"](#).
- NG >> Repair or replace harness.

## Lifting Sensor (Front) Circuit Inspection

EIS004FZ

### 1. CHECK FUNCTION

#### With CONSULT-II

Check operation with "LIFT FR PULSE" on the DATA MONITOR to make sure the pulse changes.

Monitor item [OPERATION or UNIT]	Contents
LIFT FR PULSE	The front lifting position (pulse) judged from the lifting sensor (front) is displayed

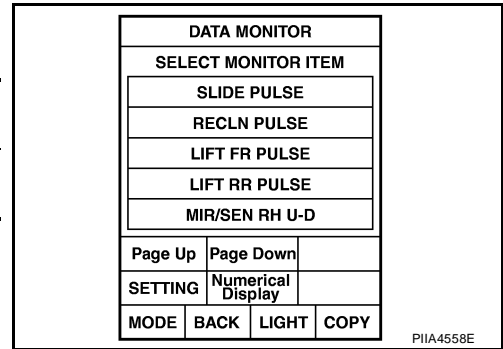

#### Without CONSULT-II

1. Turn ignition switch OFF.
2. Check signal between driver seat control unit connector and ground, with oscilloscope.

Connector	Terminals		Condition	Signal
	(+)	(-)		
P2	25	Ground	Lifting motor (front) operation	

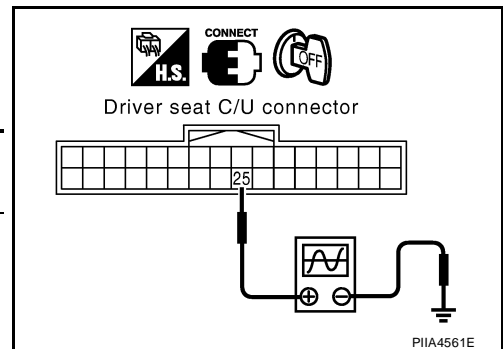

OK or NG

- OK >> Lifting sensor (front) is OK.
- NG >> GO TO 2.

# FRONT SEAT

PF87000

EIS004GP

## FRONT SEAT

### Removal and Installation

#### Driver Seat

SEC. 870

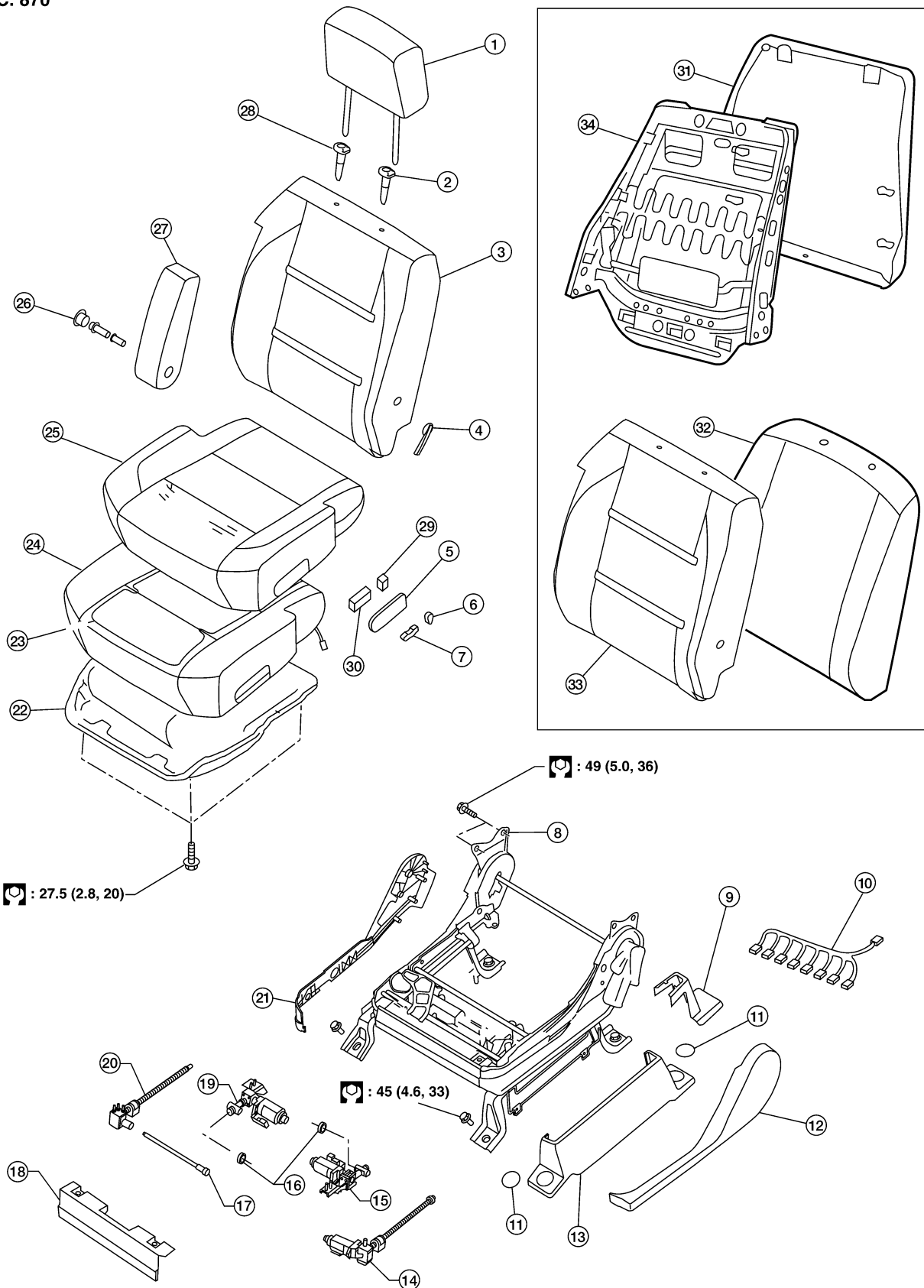

WI1A1095E

# TROUBLE DIAGNOSIS

7. Diagnostic code is displayed on "SELF-DIAG [CURRENT]".

SELF-DIAG [CURRENT]
DTC RESULTS
DRIVER AIRBAG MODULE [OPEN] [B1049]

WHIA0151E

A  
B  
C  
D  
E  
F  
G

If no malfunction is detected on "SELF-DIAG [CURRENT]" even though malfunction is detected in "SRS Operation Check", refer to [SRS-30, "DIAGNOSTIC PROCEDURE 4 \(CONTINUED FROM DIAGNOSTIC PROCEDURE 2\)"](#) , to diagnose the following cases:

- Self-diagnostic result "SELF-DIAG [PAST]" (previously stored in the memory) might not be erased after repair.
- The SRS system malfunctions intermittently.

SELF-DIAG [CURRENT]
DTC RESULTS:
NO DTC IS DETECTED. FURTHER TESTING MAY BE REQUIRED.

SRS701

SRS

## COLLISION DIAGNOSIS

Part	SRS is activated	SRS is NOT activated
Seat belt pre-tensioner assemblies (All applicable locations: buckle, reel, lap outer)	<p>If either the driver or passenger seat belt pre-tensioner* has been activated: REPLACE all seat belt pre-tensioner assemblies with new fasteners.</p> <p>*: Confirm seat belt pre-tensioner activation using CONSULT-II only.</p>	<p>If the pre-tensioners have NOT been activated:</p> <ol style="list-style-type: none"> <li>1. Remove seat belt pre-tensioners. Check harness cover and connectors for damage, terminals for deformities, and harness for binding.</li> <li>2. Check belts for damage and anchors for loose mounting.</li> <li>3. Check retractor for smooth operation.</li> <li>4. Check seat belt adjuster for damage.</li> <li>5. Check for deformities of the center pillar inner.</li> <li>6. If the center pillar inner has no damage, REPLACE the seat belt pre-tensioner assembly.</li> <li>7. If no damage is found, reinstall seat belt pre-tensioner assembly.</li> <li>8. If damaged—REPLACE. Install the seat belt pre-tensioners with new fasteners.</li> </ol>
Seat (with front side air bag)	<p>If either the front LH or front RH side air bag modules has been deployed: REPLACE front seat-back assembly on the deployed side.</p>	<p>If the front LH or front RH side air bag modules have NOT deployed:</p> <ol style="list-style-type: none"> <li>1. Visually check the seat on the collision side.</li> <li>2. Remove the seat on the collision side and check the following for damage and deformities. <ul style="list-style-type: none"> <li>– Harness, connectors and terminals</li> <li>– Frame and recliner (for front and rear seat), and also adjuster and slides (for front seat)</li> </ul> </li> <li>3. If no damage is found, reinstall the seat.</li> <li>4. If damaged—REPLACE the damaged seat parts using new fasteners. If the front seat back is damaged, the front seat back assembly must be replaced.</li> </ol>
Center inner pillar	<ol style="list-style-type: none"> <li>1. Check the center inner pillar on the collision side for damage (dents, cracks, deformation).</li> <li>2. If damaged—REPAIR the center inner pillar.</li> </ol>	
Trim/headlining	<ol style="list-style-type: none"> <li>1. Check for visible signs of damage (dents, cracks, deformation) of the interior trim on the collision side.</li> <li>2. If damaged—REPLACE the damaged trim parts.</li> </ol>	

# TROUBLE DIAGNOSIS

Monitored item (Unit)	Monitor item selection			Remarks	
	ECU INPUT SIGNALS	MAIN SIGNALS	SELECTION FROM MENU		
4L POSI SW [ON/OFF]	×	–	×	This means 4LO switch. 4LO switch signal status is displayed.	A
ATP SWITCH [ON/OFF]	×	–	×	ATP switch signal status is displayed.	B
WAIT DETCT SW [ON/OFF]	×	–	×	Wait detection switch signal status is displayed.	C
4WD MODE [2H/4H/4L]	–	×	×	Control status of 4WD recognized by transfer control unit. (2WD, 4H or 4LO)	TF
VHCL/S COMP [km/h] or [mph]	–	×	×	Vehicle speed recognized by transfer control unit.	
SHIFT ACT 1 [ON/OFF]	–	×	×	Output condition to actuator motor (clockwise)	E
SHIFT AC MON 1 [ON/OFF]	–	–	×	Check signal for transfer control unit signal output	F
SHIFT ACT 2 [ON/OFF]	–	×	×	Output condition to actuator motor (counterclockwise)	G
SHIFT AC MON 2 [ON/OFF]	–	–	×	Check signal for transfer control unit signal output	H
SFT ACT/R MON [ON/OFF]	–	–	×	Operating condition of actuator motor relay (integrated in transfer control unit)	I
SHIFT POS SW 1 [ON/OFF]	×	–	×	Condition of actuator position switch 1	J
SHIFT POS SW 2 [ON/OFF]	×	–	×	Condition of actuator position switch 2	K
SHIFT POS SW 3 [ON/OFF]	×	–	×	Condition of actuator position switch 3	L
SHIFT POS SW 4 [ON/OFF]	×	–	×	Condition of actuator position switch 4	M
4WD FAIL LAMP [ON/OFF]	–	×	×	Control status of 4WD warning lamp is displayed.	
2WD IND [ON/OFF]	–	–	×	Control status of 4WD shift indicator lamp (rear) is displayed.	
4H IND [ON/OFF]	–	–	×	Control status of 4WD shift indicator lamp (front and center) is displayed.	
4L IND [ON/OFF]	–	–	×	Control status of 4LO indicator lamp is displayed.	
Voltage [V]	–	–	×	The value measured by the voltage probe is displayed.	
Frequency [Hz]	–	–	×	The value measured by the pulse probe is displayed.	
DUTY-HI (high) [%]	–	–	×		
DUTY-LOW (low) [%]	–	–	×		
PLS WIDTH-HI [msec]	–	–	×		
PLS WIDTH-LOW [msec]	–	–	×		

## Self-Diagnostic Procedure

EDS003C7

### ① SELF-DIAGNOSTIC PROCEDURE (WITH CONSULT-II)

Refer to [TF-35, "SELF-DIAG RESULT MODE"](#).

### ② SELF-DIAGNOSTIC PROCEDURE (WITHOUT CONSULT-II)

#### Description

If the engine starts when there is something wrong with the 4WD system, the 4WD warning lamp turns ON or flickers in the combination meter. When the system functions properly, the warning lamp turns ON when the ignition switch is turned to "ON", and it turns OFF after engine starts. To locate the cause of a problem, start the self-diagnosis function. The 4WD warning lamp in the combination meter will indicate the problem area by

## TROUBLE DIAGNOSIS FOR SYMPTOMS

---

### TROUBLE DIAGNOSIS FOR SYMPTOMS

PFP:00007

#### **4WD Shift Indicator Lamp and 4LO Indicator Lamp Do Not Turn ON**

*EDS003CM*

#### **SYMPTOM:**

4WD shift indicator lamp and 4LO indicator lamp do not turn ON for approx. 1 second when turning ignition switch to "ON".

CLICK HERE TO **DOWNLOAD** THE COMPLETE MANUAL

- Thank you very much for reading the preview of the manual.
- You can download the complete manual from: [www.heydownloads.com](http://www.heydownloads.com) by clicking the link below



- Please note: If there is no response to CLICKING the link, please download this PDF first and then click on it.

CLICK HERE TO **DOWNLOAD** THE COMPLETE MANUAL