



SERVICE MANUAL

2005 CROSSFIRE

To order the special service tools used and illustrated, please refer to the instructions on inside back cover.

NO PART OF THIS PUBLICATION MAY BE REPRODUCED, STORED IN A RETRIEVAL SYSTEM, OR TRANSMITTED, IN ANY FORM OR BY ANY MEANS, ELECTRONIC, MECHANICAL, PHOTOCOPYING, RECORDING, OR OTHERWISE, WITHOUT THE PRIOR WRITTEN PERMISSION OF DAIMLERCHRYSLER CORPORATION.

DaimlerChrysler Corporation reserves the right to make changes in design or to make additions to or improvements in its products without imposing any obligations upon itself to install them on its products previously manufactured.

Litho in U.S.A. Copyright © 2004 DaimlerChrysler Corporation
6.2M0403

81-270-05036

CLICK HERE TO **DOWNLOAD** THE COMPLETE MANUAL

- Thank you very much for reading the preview of the manual.
- You can download the complete manual from: www.heydownloads.com by clicking the link below



- Please note: If there is no response to CLICKING the link, please download this PDF first and then click on it.

CLICK HERE TO **DOWNLOAD** THE COMPLETE MANUAL

5. Loosen the hub nut bolt. Turn the hub nut (4) back until a slight end play is achieved.
6. Attach a dial indicator.

CAUTION: Do not turn the wheel hub while taking the measurement.

7. Adjust the wheel bearing end play by turning the hub nut (4) in stages while pushing and pulling the rotor firmly back and forth. Adjust end play to 0.01–0.02 mm.
8. Tighten the hub nut bolt to 11 N·m (8 ft. lbs.) and recheck the wheel bearing end play.
9. Remove the dial indicator.
10. Install the wheel hub dust cap (2).
11. Remove the wheel bolt from the rotor.
12. Install the front wheel and tire assembly.

SPECIFICATIONS - TORQUE

TORQUE SPECIFICATIONS

DESCRIPTION	N·m	Ft. Lbs.	In. Lbs.
Front Shock Absorber Upper Nut	18	13	159
Front Shock Absorber Lower Nut	55	41	487
Front Sway Bar To Lower Control Arm Nut	20	15	177
Front Sway Bar Bushing Nuts			
M10	40	30	354
M8	20	15	177
Front Sway Bar To Frame Nut	60	44	531
Upper Control Arm Joint To Steering Knuckle	45	33	398
Clamping Nut	11	8	97
Lower Ball Joint To Steering Knuckle	140	103	1240
Lower Ball Joint To lower Control Arm	105	77	929
Upper Control Arm To Body Nut	65	50	575
Lower Control Arm To Frame Nut	120	88	1060

5. Remove the disc brake rotor (1). (Refer to 5 - BRAKES/HYDRAULIC/MECHANICAL/ROTORS - REMOVAL).

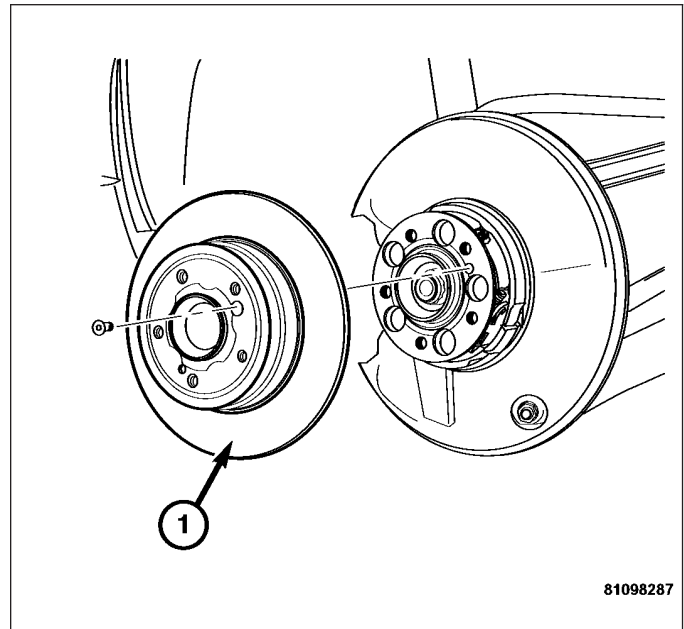

6. Remove the parking brake shoe assembly. (Refer to 5 - BRAKES/PARKING BRAKE/SHOES - REMOVAL).

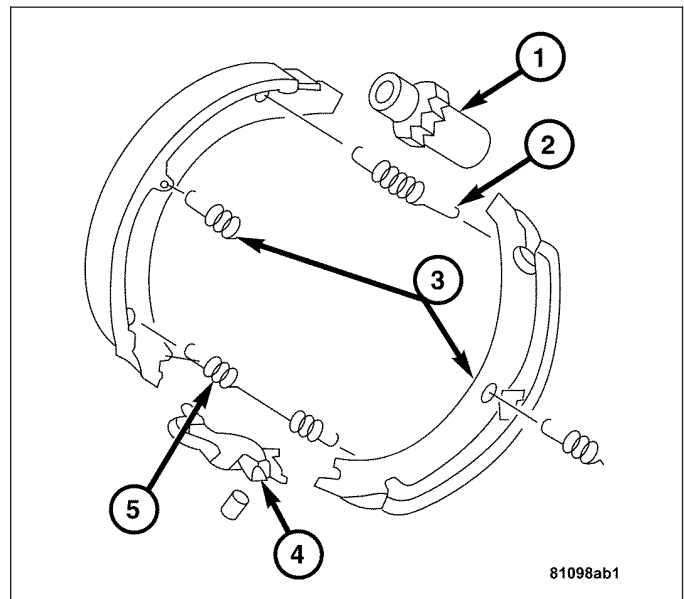

7. Remove the parking brake cable (2). (Refer to 5 - BRAKES/PARKING BRAKE/CABLES - REMOVAL).

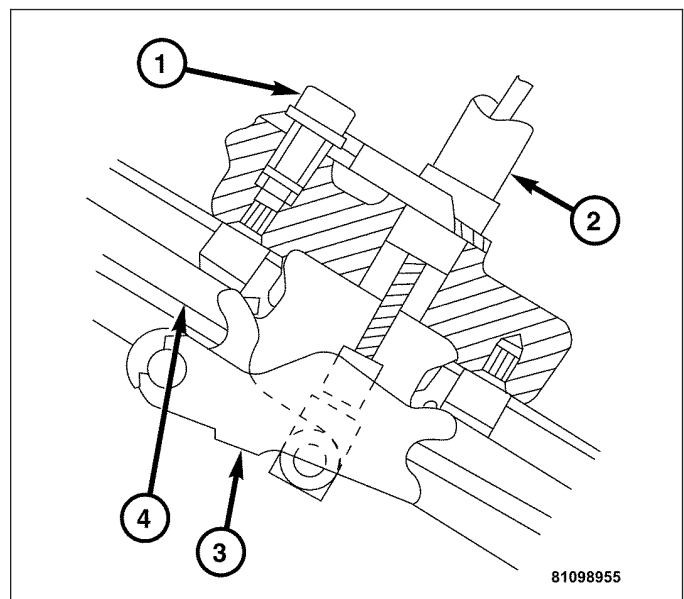

3. Improper wheel alignment.

VIBRATION AT HIGHWAY SPEEDS

This problem could be a result of:

1. Foreign material (mud, snow, etc. packed on the backside of the wheels).
2. Out of balance tires or wheels.
3. Improper tire and/or wheel runout.

REMOVAL

1. Raise and support the vehicle.
2. Remove the rear wheels.
3. Remove the rear knuckle (1). (Refer to 2 - SUSPENSION/REAR/KNUCKLE - REMOVAL)

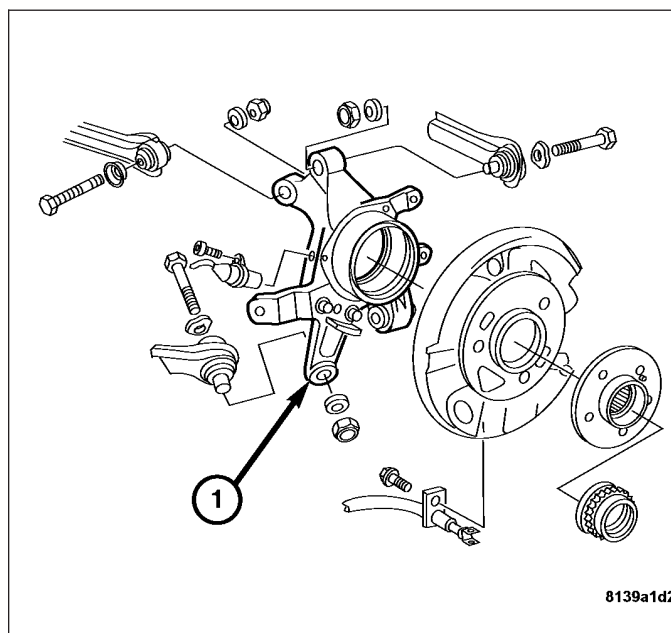

Note: The axle halfshafts are seated in the differential side gears using expandable snap rings. It is necessary to forcefully pry the halfshaft out of the differential.

4. Insert a pry bar between the differential housing and the halfshaft (1).
5. Pry against differential housing until the halfshaft retaining snap ring is disengaged from the differential side gear.

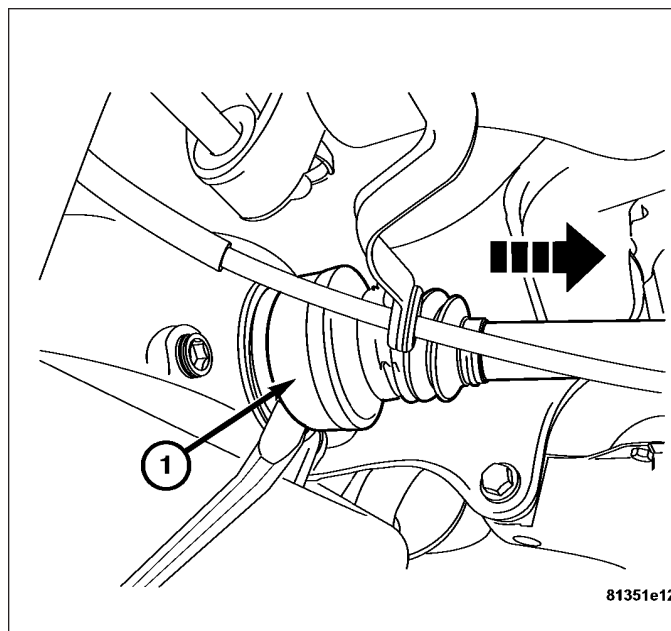

REAR DIFFERENTIAL HOUSING

REMOVAL

1. Raise and support the vehicle.
2. Remove the propeller shaft. (Refer to 3 - DIFFERENTIAL & DRIVELINE/PROPELLER SHAFT - REMOVAL).
3. Drain the rear differential housing. (Refer to 3 - DIFFERENTIAL & DRIVELINE/REAR AXLE - STANDARD PROCEDURE).
4. Support the differential housing with a jack.
5. Separate the halfshafts from the differential connecting flanges and tie them to the rear differential carrier. (Refer to 3 - DIFFERENTIAL & DRIVELINE/HALF SHAFT - REMOVAL).
6. Remove the differential housing front mounting bolt (1).

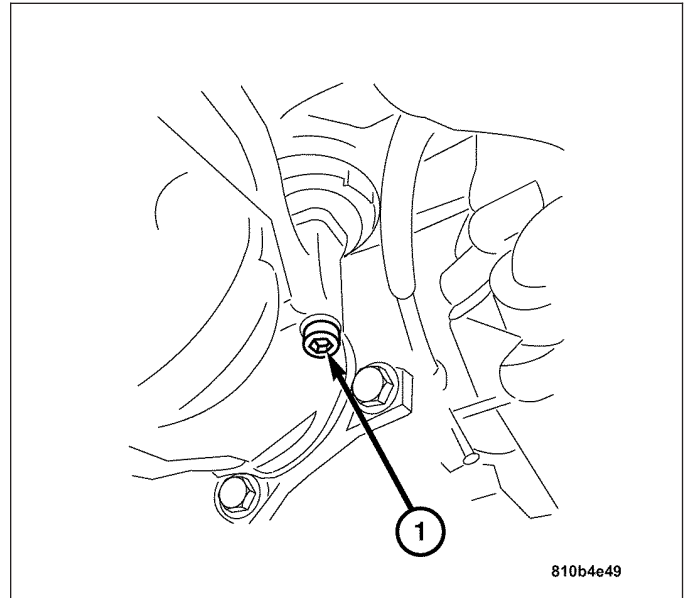

7. Remove the two differential housing rear mounting bolts (1).
8. Carefully remove the differential housing from the vehicle.

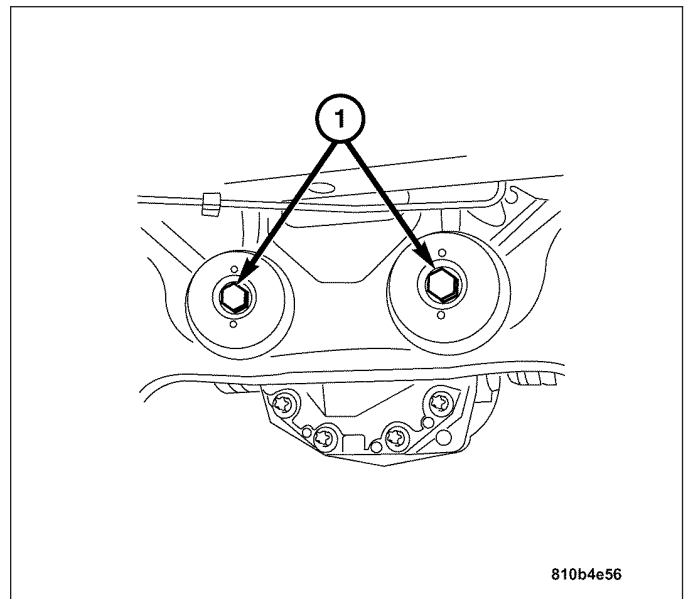

CAUTION: Verify the brake hose is not twisted or kinked before installing the caliper to the knuckle.

3. Install the caliper to the knuckle. Install the mounting bolts. Tighten to 55 N·m (41 ft. lbs.).

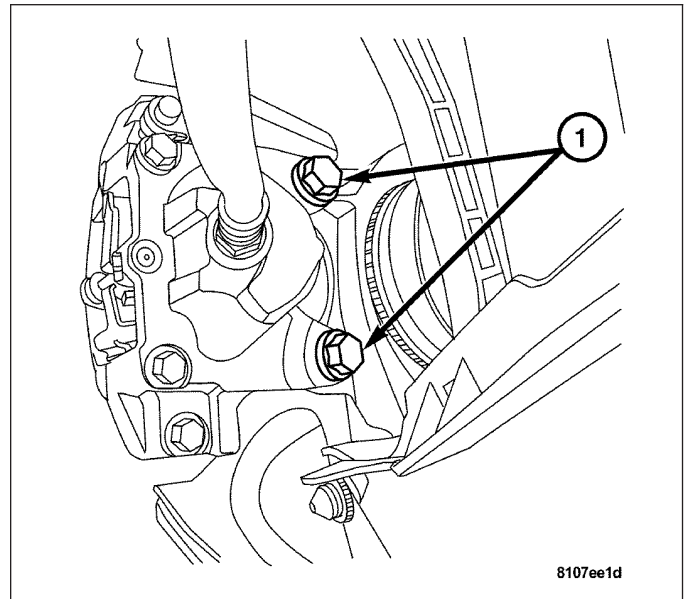

4. Fill and bleed the brake system.
 - Manual bleeding: (Refer to 5 - BRAKES - STANDARD PROCEDURE).
 - Pressure bleeding: (Refer to 5 - BRAKES - STANDARD PROCEDURE).
5. Install the wheel and tire assembly.

WARNING: DO NOT MOVE VEHICLE UNTIL FIRM BRAKE PEDAL IS OBTAINED.

6. Lower the vehicle.
7. Pump the brake pedal until the caliper pistons and the brake pads are seated and a firm brake pedal is achieved.
8. Top off the brake fluid reservoir with new fluid if necessary, and check for leaks.

INSTALLATION

1. Install the front parking brake cable (1) through the hole in the floor. Then install the parking brake lever and bolts (2). Tighten to 20 N·m (15 ft. lbs.).
2. Connect the parking brake switch harness connector.

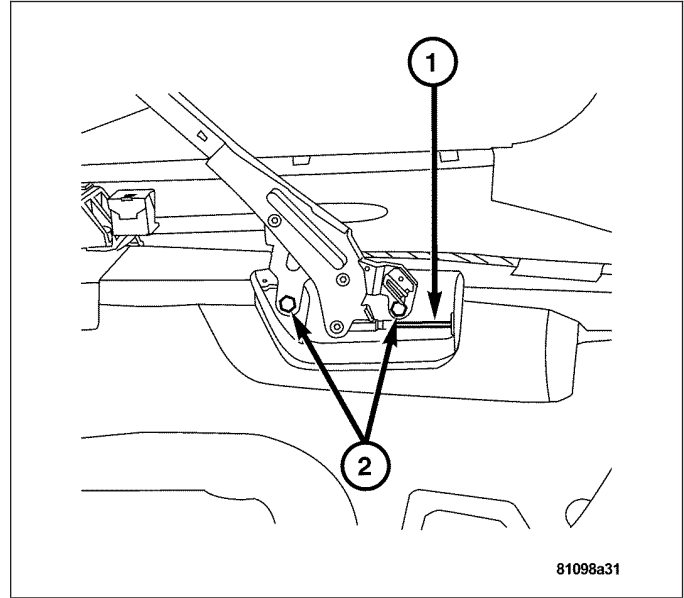

3. Install the center console (2). (Refer to 23 - BODY/ INTERIOR/CENTER CONSOLE - INSTALLATION).
4. Install the rubber handle (1) onto the parking brake lever.

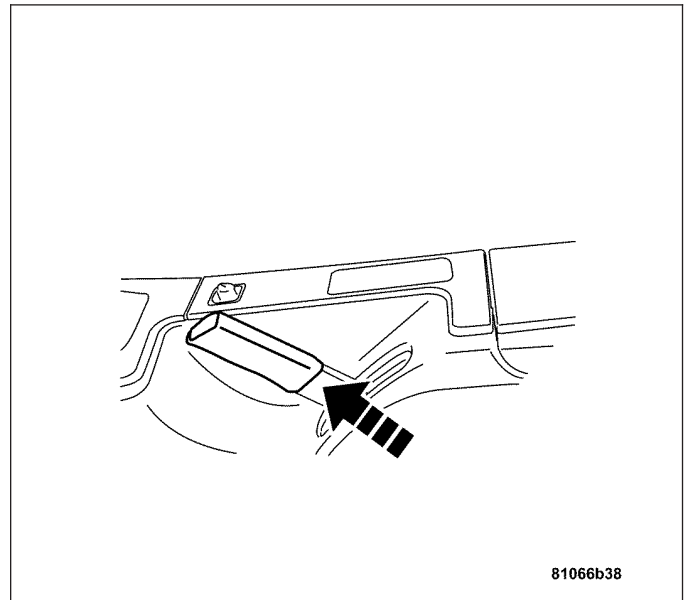

5. Install the shifter bezel (1). (Refer to 23 - BODY/ INTERIOR/CENTER CONSOLE - INSTALLATION).

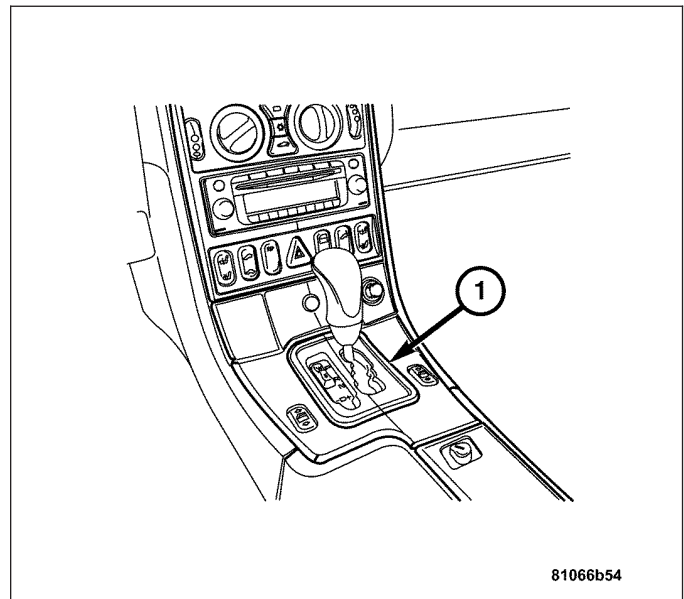

RIGHT FRONT WHEEL SPEED SENSOR CIRCUIT (CONTINUED)**5. CHECK THE RIGHT FRONT WHEEL SPEED SENSOR 12 VOLT SUPPLY CIRCUIT FOR A SHORT TO VOLTAGE**

With the ignition off.

Disconnect the CAB harness connector.

Note: Check connectors - Clean/repair as necessary.

Measure the voltage of the Right Front Wheel Speed Sensor 12 Volt Supply circuit.

Is the voltage below 1.0 volt?

- Yes** >> Replace the Controller Antilock Brake. (Refer to 8 - ELECTRICAL/ELECTRONIC CONTROL MODULES/CONTROLLER ANTILOCK BRAKE - REMOVAL).
Perform ABS VERIFICATION TEST.
- No** >> Repair the Right Front Wheel Speed Sensor 12 Volt Supply circuit for a short to voltage.
Perform ABS VERIFICATION TEST.

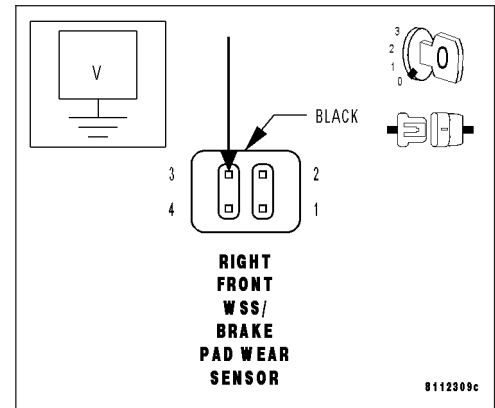
**6. MEASURE THE RESISTANCE BETWEEN GROUND AND THE RIGHT FRONT WHEEL SPEED SENSOR 12 VOLT SUPPLY CIRCUIT**

With the ignition off.

Disconnect the CAB harness connector.

Note: Check connectors - Clean/repair as necessary.

Measure the resistance between ground and the Right Front Wheel Speed Sensor 12 Volt Supply circuit at the CAB harness connector.

Is the resistance below 100 kohms?

- Yes** >> Repair the Right Front Wheel Speed Sensor 12 Volt Supply circuit for a short to ground.
Perform ABS VERIFICATION TEST.
- No** >> Go to 7

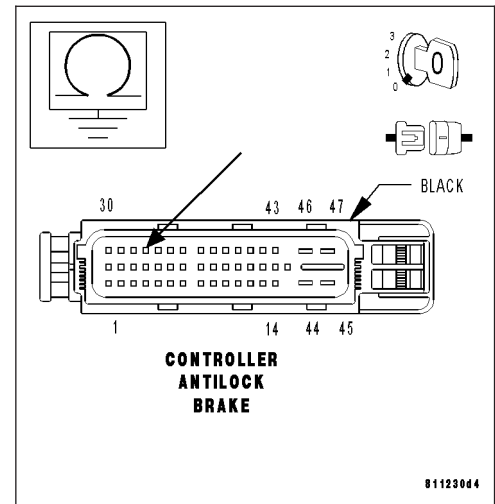

ESP BRAKE PRESSURE SENSOR 2 CIRCUIT (CONTINUED)

When Monitored and Set Condition

- When Monitored: Ignition on.
- Set Condition: The Controller Antilock Brake (CAB) detects an Electronic Stability Program (ESP) Brake Pressure Sensor 2 malfunction.

POSSIBLE CAUSES
BRAKE PRESSURE SENSOR SIGNAL CIRCUIT SHORT TO VOLTAGE
BRAKE PRESSURE SENSOR SIGNAL CIRCUIT SHORT TO 5-VOLT SUPPLY CIRCUIT
BRAKE PRESSURE SENSOR SIGNAL CIRCUIT SHORT TO GROUND
BRAKE PRESSURE SENSOR SIGNAL CIRCUIT SHORT TO SENSOR GROUND CIRCUIT
BRAKE PRESSURE SENSOR SIGNAL CIRCUIT OPEN
BRAKE PRESSURE SENSOR 5-VOLT SUPPLY CIRCUIT SHORT TO VOLTAGE
BRAKE PRESSURE SENSOR 5-VOLT SUPPLY CIRCUIT OPEN
BRAKE PRESSURE SENSOR 5-VOLT SUPPLY CIRCUIT SHORT TO GROUND
BRAKE PRESSURE SENSOR 5-VOLT SUPPLY CIRCUIT SHORT TO SENSOR GROUND
BRAKE PRESSURE SENSOR GROUND CIRCUIT OPEN
BRAKE PRESSURE SENSOR
CONTROLLER ANTILOCK BRAKE

For a complete Electronic Stability Program (ESP) Circuit Diagram (Refer to 5 - BRAKES/ELECTRICAL - SCHEMATICS AND DIAGRAMS).

Diagnostic Test

1. MEASURE THE VOLTAGE OF THE ESP BRAKE PRESSURE SENSOR 2 SIGNAL CIRCUIT

- Turn the ignition off.
- Disconnect the CAB harness connector.
- Disconnect the ESP Brake Pressure Sensor 2 harness connector.

Note: Check connectors - Clean/repair as necessary.

- Turn the ignition on.
- Measure the voltage of the ESP Brake Pressure Sensor 2 Signal circuit at the ESP Brake Pressure Sensor 2 harness connector.

Is the voltage below 1.0 volt?

- Yes** >> Go to 2
- No** >> Repair the ESP Brake Pressure Sensor 2 Signal circuit for a short to voltage.
Perform ABS VERIFICATION TEST.

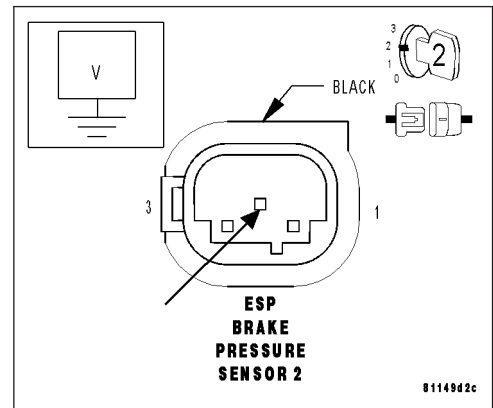

8114902c

PCM NOT IDENTIFIED OR INCORRECT (CONTINUED)**When Monitored and Set Condition**

- When Monitored: Continuous.
- Set Condition: If the Controller Antilock Brake (CAB) detects an invalid Powertrain Control Module (PCM), the DTC is set.

POSSIBLE CAUSES

CONTROLLER ANTILOCK BRAKE

For a complete Brake Assist System (BAS) Circuit Diagram (Refer to 5 - BRAKES/ELECTRICAL - SCHEMATICS AND DIAGRAMS).

Diagnostic Test**1. WITH THE DRB III®, READ DTCs**

Turn the ignition on.

With the DRB III®, erase DTCs.

Turn the ignition off.

Turn the ignition on.

Start the engine.

CAUTION: Ensure braking capability is available before road testing.

Drive the vehicle above 16 km/h (10 MPH) for at least 20 seconds.

Stop the vehicle.

With the DRB III®, read DTCs.

Does the DRB III® display a PCM Not Identified or Incorrect DTC?

Yes >> Replace the Controller Antilock Brake. (Refer to 8 - ELECTRICAL/ELECTRONIC CONTROL MODULES/CONTROLLER ANTILOCK BRAKE - REMOVAL).

Perform ABS VERIFICATION TEST.

No >> The condition that caused this DTC to set is currently not present.

Perform ABS VERIFICATION TEST.

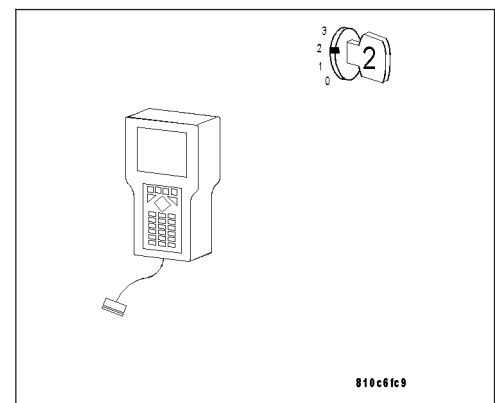

BAS SOLENOID VALVE CIRCUIT (CONTINUED)

8. MEASURE THE RESISTANCE OF THE BAS SOLENOID VALVE CONTROL CIRCUIT

With the ignition off.

Reconnect the CAB harness connector.

Measure the resistance between ground and the BAS Solenoid Valve Control circuit.

Is the resistance 23.5 – 24.5 kohms?

Yes >> Replace the BAS Brake Booster. (Refer to 5 - BRAKES/HYDRAULIC/MECHANICAL/POWER BRAKE BOOSTER - REMOVAL).

No >> Replace the Controller Antilock Brake. (Refer to 8 - ELECTRICAL/ELECTRONIC CONTROL MODULES/CONTROLLER ANTILOCK BRAKE - REMOVAL).
Perform ABS VERIFICATION TEST.

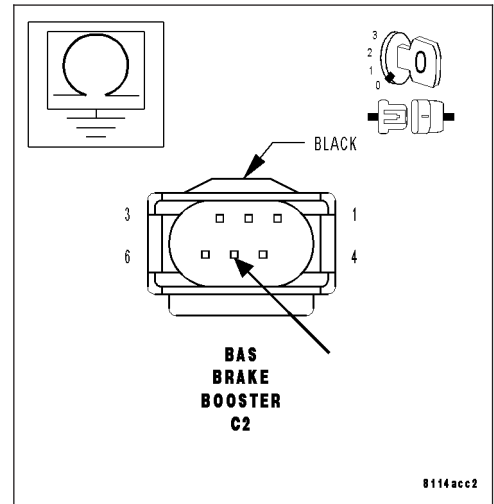

INSTALLATION

1. If the clutch cover is to be reused, adjustment is required on the clutch disc. Use an old release bearing or a length of pipe to release diaphragm pressure. Set the adjusting ring to the mark as shown.

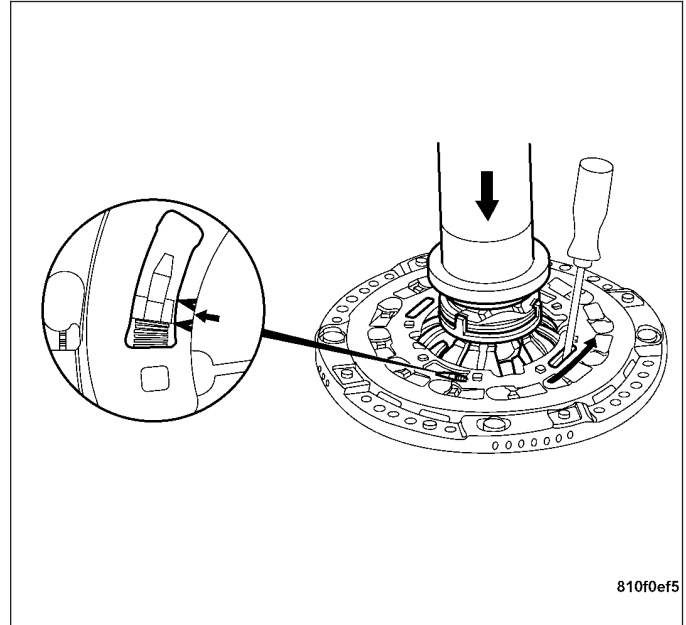

2. Position the clutch disc and clutch cover on the fly-wheel.
3. Loosely install the clutch cover bolts (1).

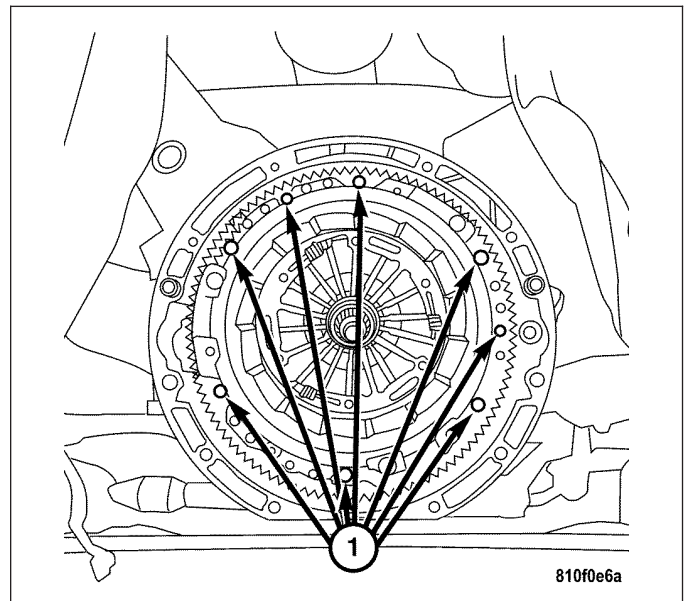

thermostat allows engine coolant to flow to the radiator. This provides quick engine warm up and overall temperature control.

The same thermostat is used for winter and summer seasons. An engine should not be operated without a thermostat, except for servicing or testing. Operating the engine without a thermostat can cause the following problems:

- Longer engine warm-up time
- Unreliable warm-up performance
- Increased exhaust emissions
- Crankcase condensation

This condensation can result in sludge formation.

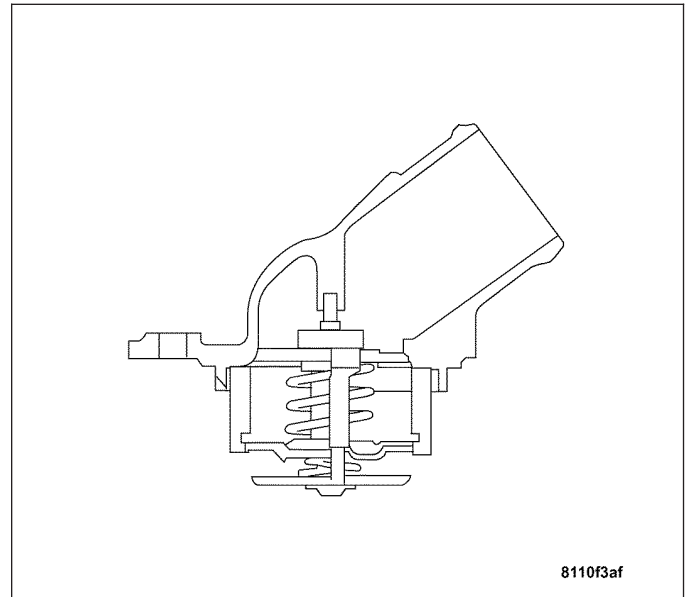

OPERATION

The wax pellet is located in a sealed container at the spring end of the thermostat. When heated, the pellet expands, overcoming closing spring tension and water pump pressure to force the valve to open.

9. Rotate the belt tensioner counterclockwise and install the accessory drive belt.
10. Release the belt tensioner and remove the wrench.

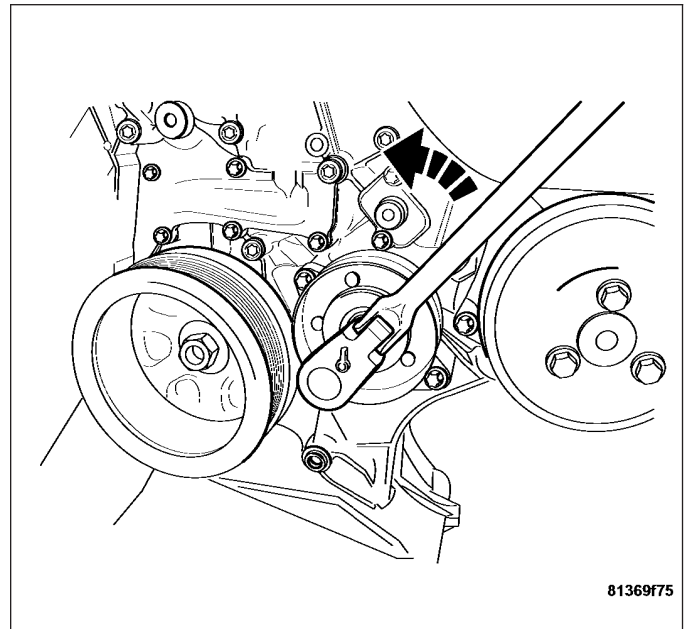

11. Install the radiator fan. (Refer to 7 - COOLING/ENGINE/RADIATOR FAN - INSTALLATION).

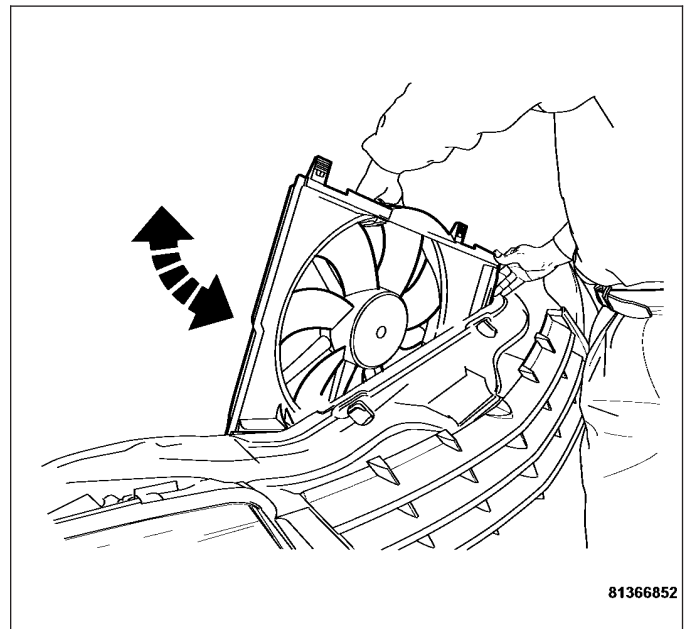

12. Install the engine cover (1). Align the engine cover retaining clips to the rubber mounts, and push down firmly to connect engine cover to rubber mounts.

Note: To ease the installation of the engine cover, apply a small amount of lubricant to the engine cover rubber mounts.

13. Install the air cleaner inlet tubes (2).
14. Connect the negative battery cable.
15. Fill the cooling system. (Refer to 7 - COOLING/ENGINE/COOLANT - STANDARD PROCEDURE).
16. Start the engine and check for coolant leaks.
17. Recheck the coolant level.

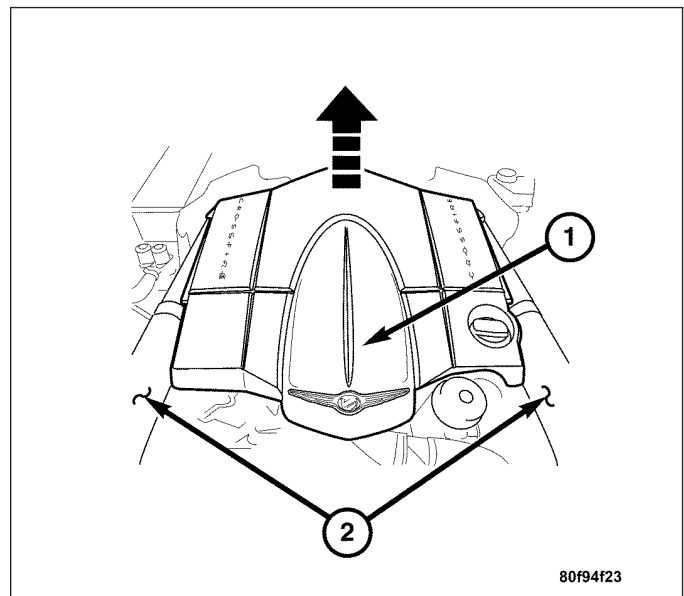

3. Install the air tube assembly (1) by installing the retaining bolts (2).

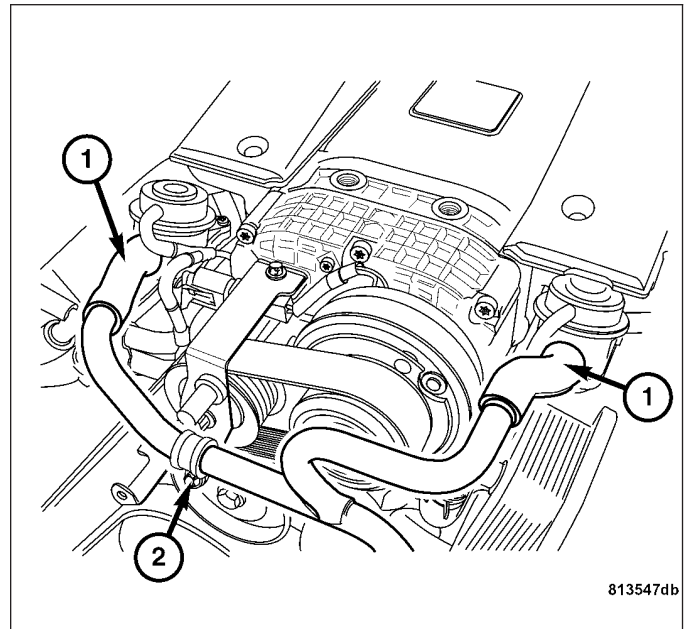

4. Install the engine cover (1). Align engine cover retaining clips to the rubber mounts, and push down firmly to connect engine cover to rubber mounts.

Note: To ease the installation of the engine cover, apply a small amount of lubricant to the engine cover rubber mounts.

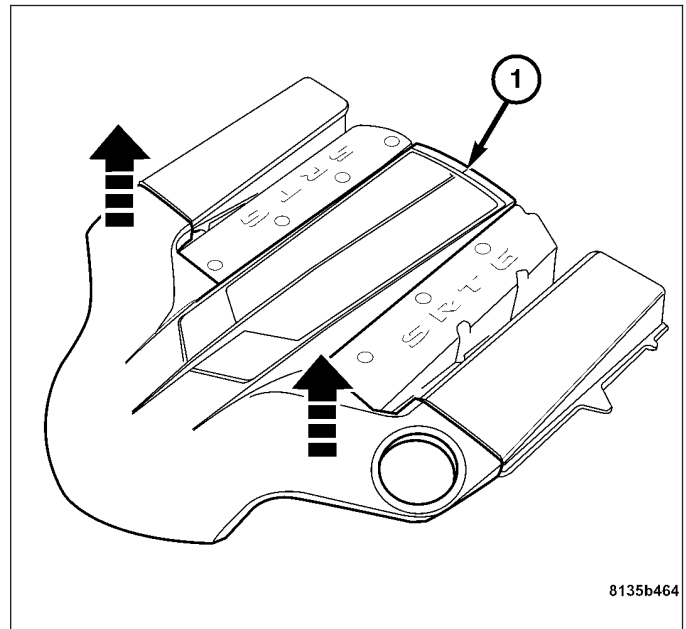

7. Disconnect the rear panel speaker harness connector (2).
8. Remove the inner mounting frame (1) together with the left or right rear panel speaker from the vehicle.

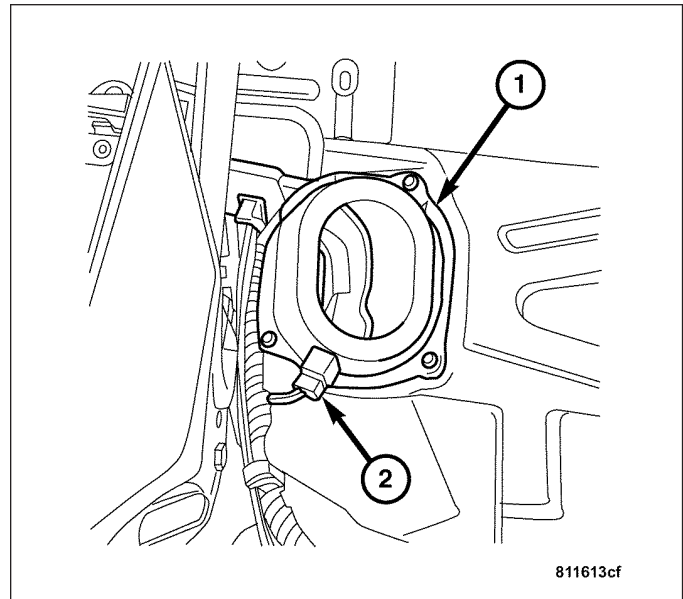

REMOVAL - TWEETER SPEAKER

WARNING: DISABLE THE AIRBAG SYSTEM BEFORE ATTEMPTING ANY STEERING WHEEL, STEERING COLUMN, SEAT BELT TENSIONER, SIDE AIRBAG, OR INSTRUMENT PANEL COMPONENT DIAGNOSIS OR SERVICE. DISCONNECT AND ISOLATE THE BATTERY NEGATIVE (GROUND) CABLE, THEN WAIT TWO MINUTES FOR THE AIR BAG SYSTEM CAPACITOR TO DISCHARGE BEFORE PERFORMING FURTHER DIAGNOSIS OR SERVICE. THIS IS THE ONLY SURE WAY TO DISABLE THE AIRBAG SYSTEM. FAILURE TO TAKE THE PROPER PRECAUTIONS COULD RESULT IN ACCIDENTAL AIRBAG DEPLOYMENT AND POSSIBLE PERSONAL INJURY.

1. Disconnect the negative battery cable.
2. Remove the door interior trim panel (1). (Refer to 23 - BODY/DOOR - FRONT/TRIM PANEL - REMOVAL).

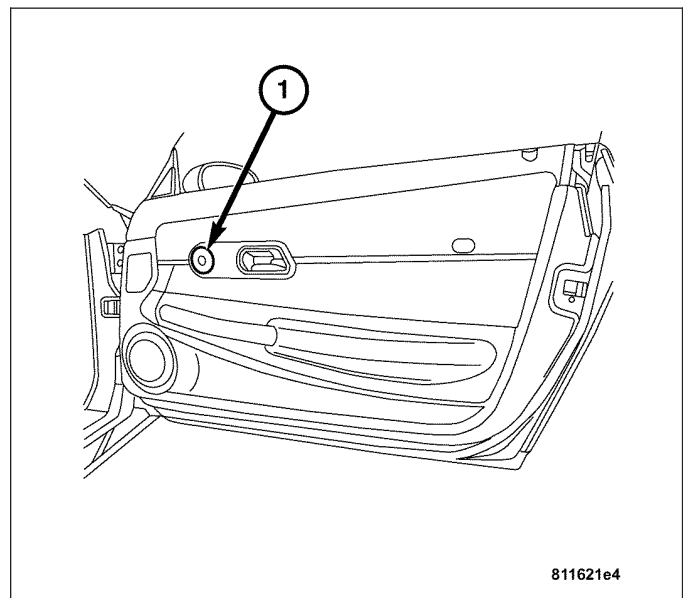

***NO RESPONSE FROM A/C HEATER CONTROL MODULE (CONTINUED)**

3. FUSED B+ CIRCUIT OPEN

Turn the ignition off.

Disconnect the A/C Heater Control Module harness connector.

Note: Check connector — Clean/repair as necessary.

Turn the ignition on.

Measure the voltage of the Fused B+ circuit at the A/C Heater Control Module harness connector.

Is the voltage above 10 volts?

Yes >> Go to 4

No >> Repair the Fused B+ circuit for an open.
Perform BODY VERIFICATION TEST.

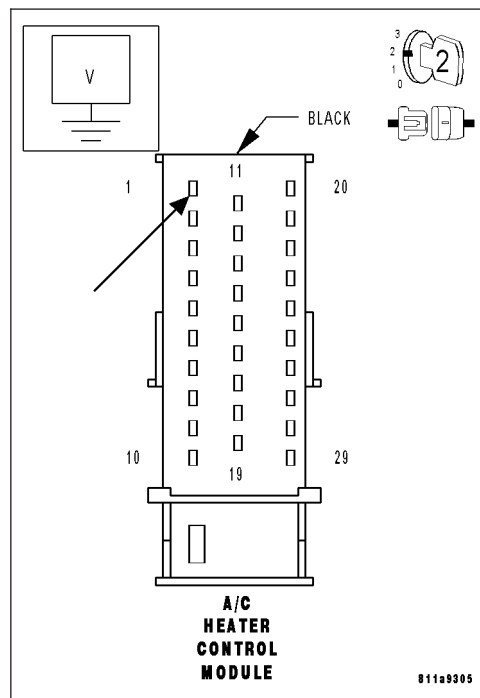

4. FUSED IGNITION SWITCH OUTPUT CIRCUIT(S) OPEN

With the ignition on.

Measure the voltage of the Fused Ignition Switch Output circuits at the A/C Heater Control Module harness connector.

Is the voltage above 10 volts?

Yes >> Go to 5

No >> Repair the Fused Ignition Switch Output circuit(s) for an open.
Perform BODY VERIFICATION TEST.

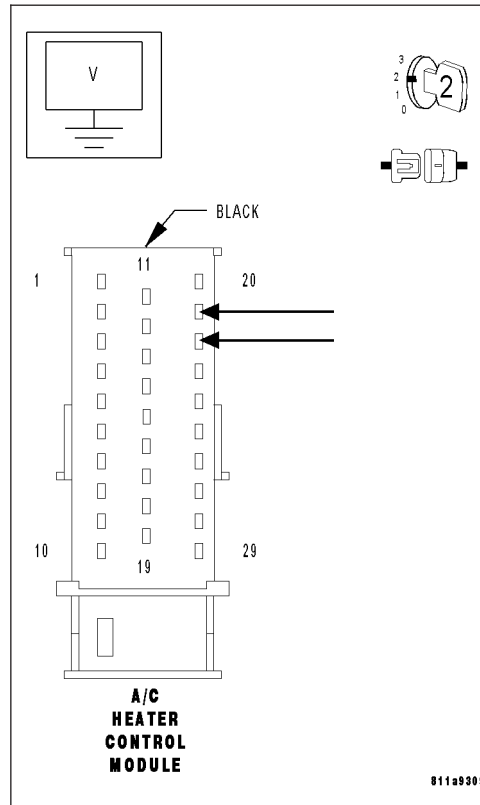

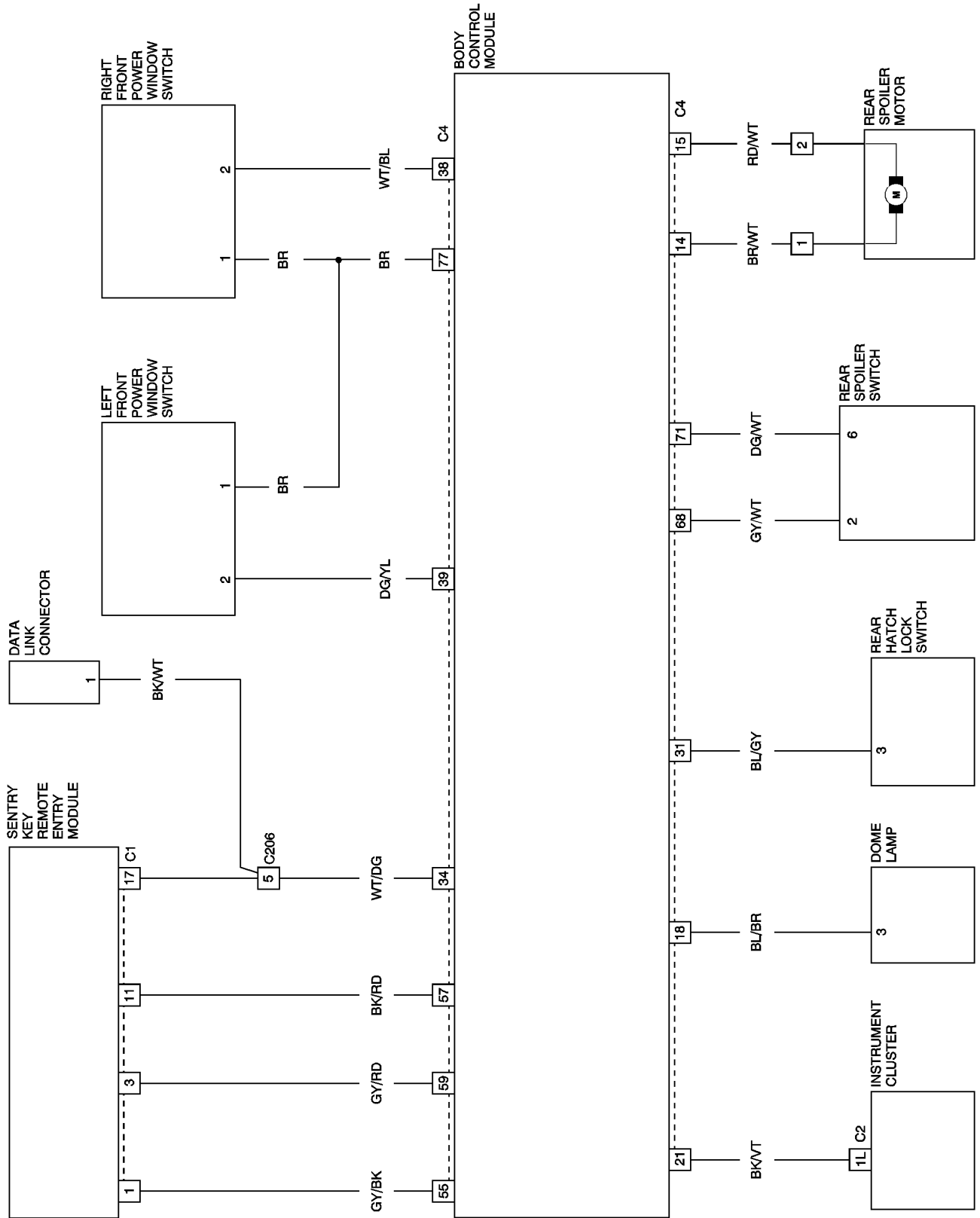

CONDITION	POSSIBLE CAUSES	CORRECTION
<p>THE BATTERY SEEMS WEAK OR DEAD WHEN ATTEMPTING TO START THE ENGINE.</p>	<ol style="list-style-type: none"> 1. The electrical system ignition-off draw is excessive. 2. The charging system is faulty. 3. The battery is discharged. 4. The battery terminal connections are loose or corroded. 5. The battery has an incorrect size or rating for this vehicle. 6. The battery is faulty. 7. The starting system is faulty. 8. The battery is physically damaged. 	<ol style="list-style-type: none"> 1. Refer to the IGNITION-OFF DRAW TEST Standard Procedure for the proper test procedures. Repair the excessive ignition-off draw as required. 2. Determine if the charging system is performing to specifications. Refer to Charging System for additional charging system diagnosis and testing procedures. Repair the faulty charging system as required. 3. Determine the battery state-of-charge using the Micro 420 battery tester. Refer to the Standard Procedures in this section for additional test procedures. Charge the faulty battery as required. 4. Refer to Battery Cables for the proper battery cable diagnosis and testing procedures. Clean and tighten the battery terminal connections as required. 5. Refer to Battery System Specifications for the proper size and rating. Replace an incorrect battery as required. 6. Determine the battery cranking capacity using the Micro 420 battery tester. Refer to the Standard Procedures in this section for additional test procedures. Replace the faulty battery as required. 7. Determine if the starting system is performing to specifications. Refer to Starting System for the proper starting system diagnosis and testing procedures. Repair the faulty starting system as required. 8. Inspect the battery for loose terminal posts or a cracked and leaking case. Replace the damaged battery as required.

OPERATION

The starter motor is equipped with a planetary gear reduction system. The planetary gear reduction system consists of a gear that is integral to the output end of the electric motor armature shaft that is in continual engagement with a larger gear that is splined to the input end of the starter pinion gear shaft. This feature makes it possible to reduce the dimensions of the starter. At the same time, it allows higher armature rotational speed and delivers increased torque through the starter pinion gear to the starter ring gear.

The starter motor is activated by an integral heavy duty starter solenoid switch mounted to the overrunning clutch housing. This electromechanical switch connects and disconnects the feed of battery voltage to the starter motor and actuates a shift fork that engages and disengages the starter pinion gear with the starter ring gear.

DIAGNOSIS AND TESTING - STARTER MOTOR

Correct starter motor operation can be confirmed by performing the following free running bench test. This test can only be performed with the starter motor removed from the vehicle. Refer to **Starting System** in the Specifications section of this group for the starter motor specifications. (Refer to 8 - ELECTRICAL/STARTING - SPECIFICATIONS).

1. Remove the starter motor from the vehicle. Refer to **Starter Motor** in the Removal and Installation section of this group for the procedures. (Refer to 8 - ELECTRICAL/STARTING/STARTER MOTOR - REMOVAL) and (Refer to 8 - ELECTRICAL/STARTING/STARTER MOTOR - INSTALLATION).
2. Mount the starter motor securely in a soft-jawed bench vise. The vise jaws should be clamped on the mounting flange of the starter motor. Never clamp on the starter motor by the field frame.
3. Connect a suitable volt-ampere tester and a 12-volt battery to the starter motor in series, and set the ammeter to the 100 ampere scale. See the instructions provided by the manufacturer of the volt-ampere tester being used.
4. Install a jumper wire from the solenoid terminal to the solenoid battery terminal. The starter motor should operate. If the starter motor fails to operate, replace the faulty starter motor assembly.
5. Adjust the carbon pile load of the tester to obtain the free running test voltage. Refer to **Starting System** in the Specifications section of this group for the starter motor free running test voltage specifications. (Refer to 8 - ELECTRICAL/STARTING - SPECIFICATIONS).
6. Note the reading on the ammeter and compare this reading to the free running test maximum amperage draw. Refer to **Starting System** in the Specifications section of this group for the starter motor free running test maximum amperage draw specifications. (Refer to 8 - ELECTRICAL/STARTING - SPECIFICATIONS).
7. If the ammeter reading exceeds the maximum amperage draw specification, replace the faulty starter motor assembly.

STARTER SOLENOID

This test can only be performed with the starter motor removed from the vehicle.

1. Remove the starter motor from the vehicle. (Refer to 8 - ELECTRICAL/STARTING/STARTER MOTOR - REMOVAL).
2. Disconnect the wire from the solenoid field coil terminal.

BODY VERIFICATION TEST**BODY VERIFICATION TEST****1.**

Turn the ignition off.

Disconnect all jumper wires and reconnect all previously disconnected components and connectors.

Note: If the SKREEM or the PCM was replaced, refer to the service information for proper programming procedures.

If the Body Control Module was replaced, turn the ignition on for 15 seconds (to allow the new BCM to learn VIN) or engine may not start.

Program all RKE transmitters and other options as necessary.

With the DRB III®, erase all Diagnostic Trouble Codes (DTCs) from ALL modules. Start the engine and allow it to run for 2 minutes. Operate all functions of the system that caused the original complaint.

Ensure that all accessories are turned off and the battery is fully charged.

Turn the ignition off and wait 5 seconds. Turn the ignition on and using the DRB III®, read DTCs from ALL modules.

Are any DTCs present or is the original complaint still present?

Are any DTCs present?

YES >> Repair is not complete, refer to appropriate symptom.

NO >> Repair is complete.

Note: When installing the spark plug cables, route the cables correctly. Failure to route the cables properly can cause improper spark plug phase-shift.

4. Install the spark plug cables to the appropriate coil tower (A & B) (coil side).
5. Install the spark plug cables to the appropriate spark plug location (G & K) (plug side).

Note: Refer to the reference pad cast into the cylinder head cover to identify proper spark plug/spark plug cable orientation.

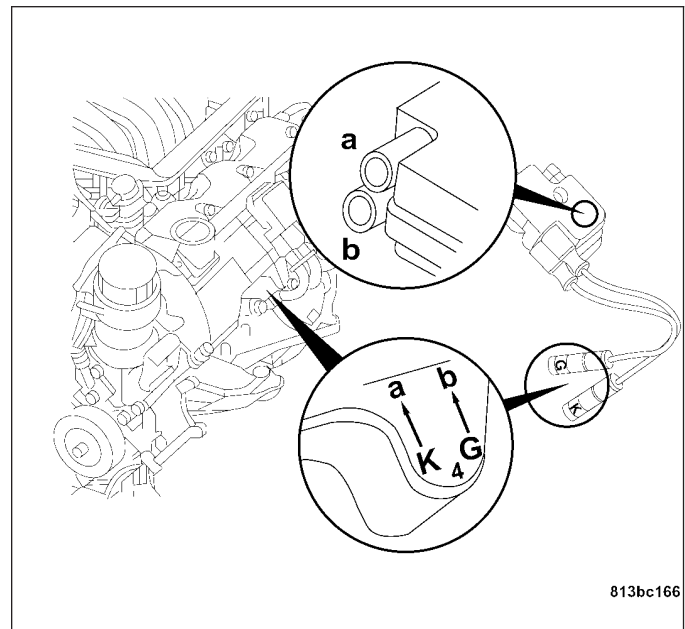

Note: When installing spark plug cables, insure a positive connection is made. A snap should be felt when a good connection is made between the spark plug cable and the spark plug.

6. Insure a firm connection is made from the spark plug cables (2) to the spark plugs.

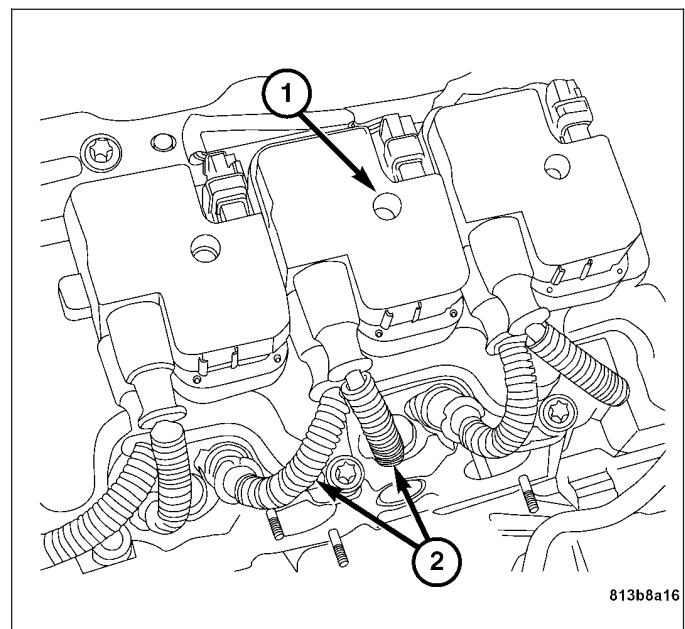

NO CAN COMMUNICATIONS WITH PCM (CONTINUED)

8. CAN C BUS (+) CIRCUIT SHORTED TO VOLTAGE

Turn the ignition on.

Measure the voltage of the CAN C Bus (+) circuit at the PCM C4 harness connector.

Is the voltage above 1.0 volt?

Yes >> Repair the CAN C Bus (+) circuit for a short to voltage.
Perform BODY VERIFICATION TEST.

No >> Go To 9

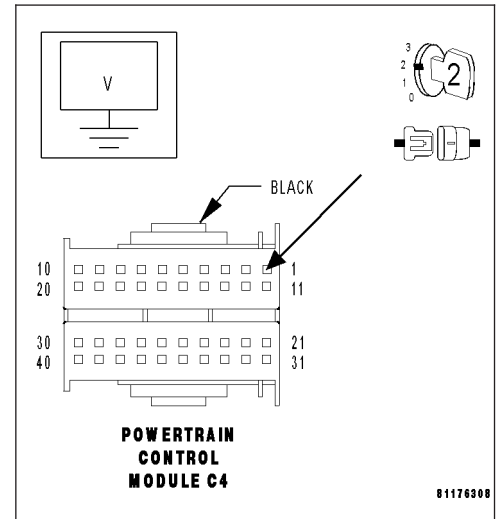

9. CAN C BUS (-) CIRCUIT SHORTED TO VOLTAGE

With the ignition on.

Measure the voltage of the CAN C Bus (-) circuit at the PCM C4 harness connector.

Is the voltage above 1.0 volt?

Yes >> Repair the CAN C Bus (-) circuit for a short to voltage.
Perform BODY VERIFICATION TEST.

No >> Go To 10

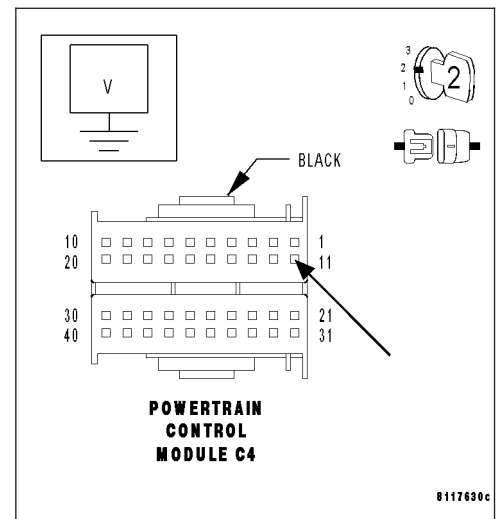

INSTRUMENT CLUSTER - SERVICE INFORMATION

TABLE OF CONTENTS

	page
INSTRUMENT CLUSTER - SERVICE INFORMATION	
DESCRIPTION	
DESCRIPTION	66
DESCRIPTION - RHD	69
OPERATION	
OPERATION	70
OPERATION - RHD	84
DIAGNOSIS AND TESTING - FUNCTION CHECK	98
STANDARD PROCEDURE	
DISPLAY OF REMAINING FSS MILEAGE AT DRIVER'S REQUEST	100
RESETTING THE FSS MAINTENANCE INDICATOR	101
RESETTING THE FSS MAINTENANCE INDICATOR AFTER AN OIL CHANGE	103
STANDARD PROCEDURE - INSTRUMENT CLUSTER BULBS	106
REMOVAL	
REMOVAL - INSTRUMENT CLUSTER	107
REMOVAL - RHD	109
INSTALLATION	
INSTALLATION - INSTRUMENT CLUSTER ..	110
INSTALLATION - RHD	111

INSTRUMENT CLUSTER - SERVICE INFORMATION

DESCRIPTION

DESCRIPTION

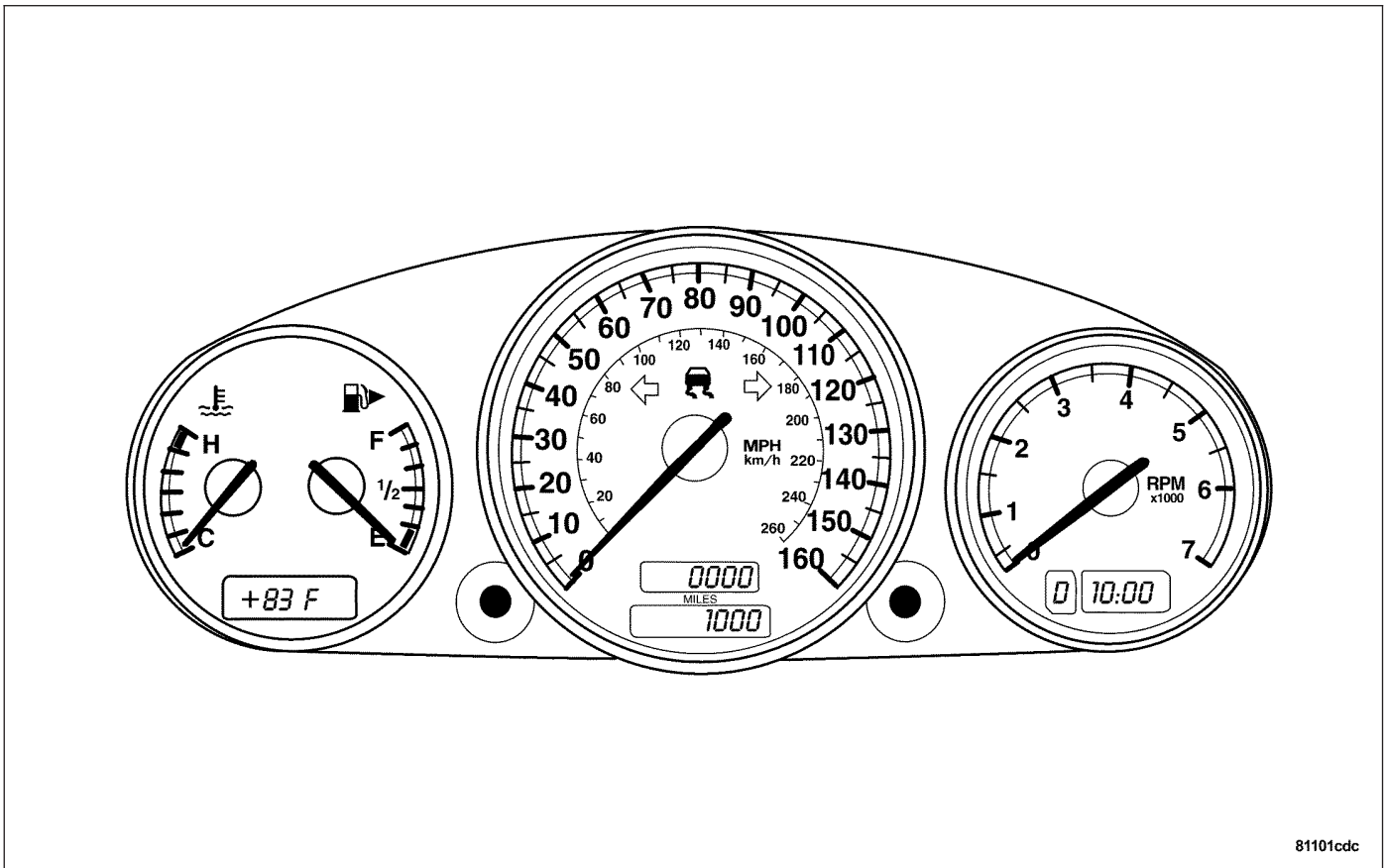

81101cdc

The Instrument Cluster is used to inform the driver of important vehicle operating conditions, and to warn the driver of potentially critical operating conditions. For this, the Instrument Cluster utilizes indicator lamps, display gauges

INSTRUMENT CLUSTER BULB INSTALLATION

1. To install the Instrument Cluster bulbs, place the bulb into the Instrument Cluster housing back and then turn the bulb clockwise until it locks.
2. Install the Instrument Cluster. (Refer to 8 - ELECTRICAL/INSTRUMENT CLUSTER - INSTALLATION).

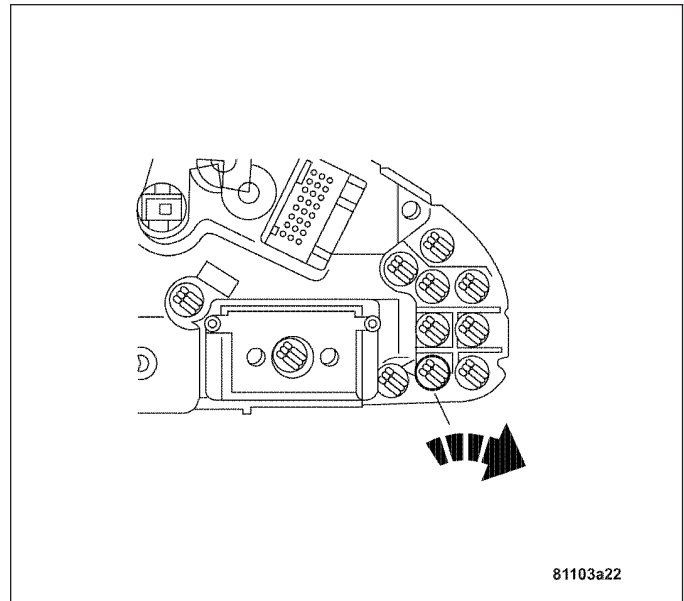

81103a22

REMOVAL

REMOVAL - INSTRUMENT CLUSTER

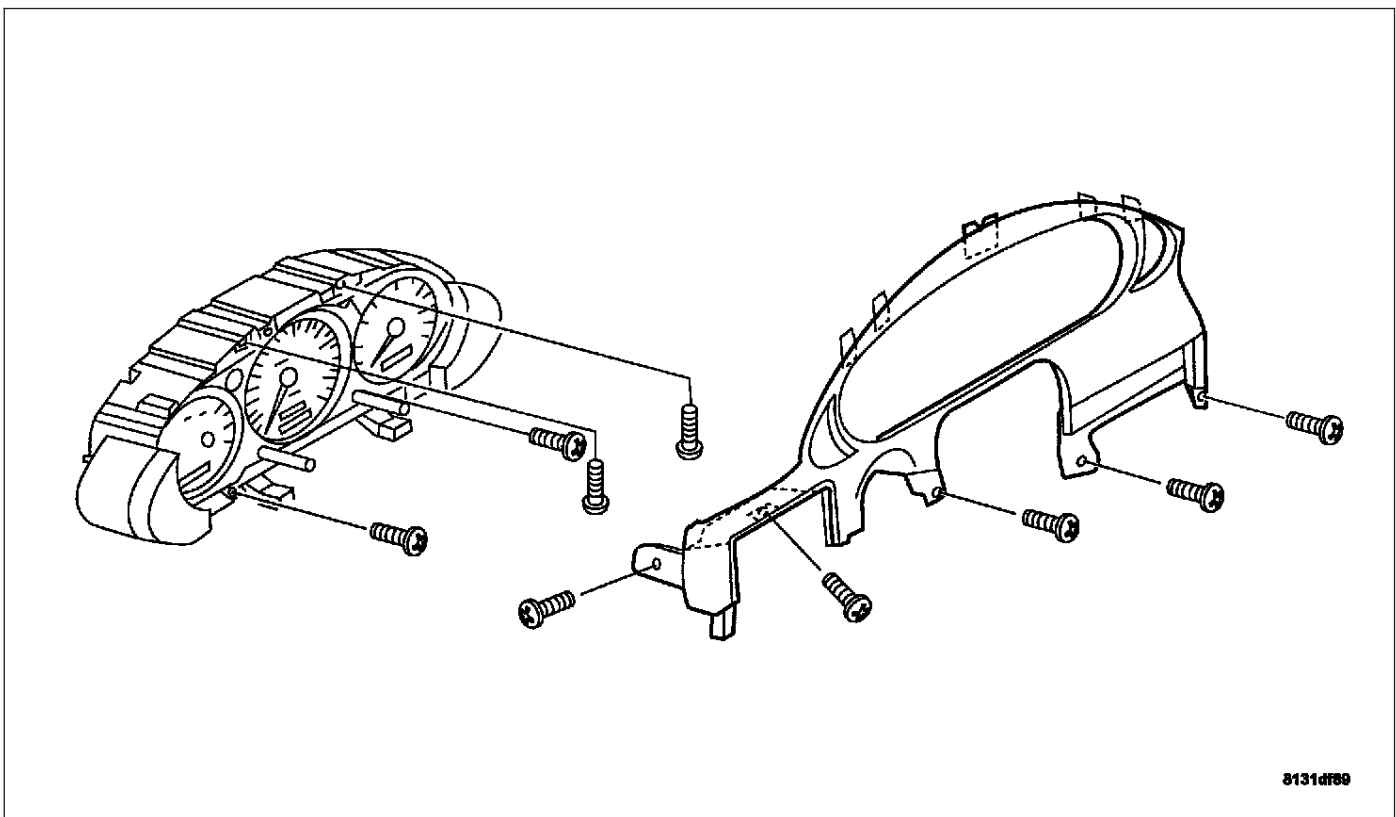

8131df89

***RIGHT FRONT SIDE MARKER LAMP INOPERATIVE (CONTINUED)**

POSSIBLE CAUSES
FUSED B(+) CIRCUIT OPEN GROUND CIRCUIT OPEN RIGHT FRONT SIDE MARKER LAMP BULB

For a complete Exterior Lamps Circuit Diagram, (Refer to 8 - ELECTRICAL/LAMPS/LIGHTING - EXTERIOR - SCHEMATICS AND DIAGRAMS).

Diagnostic Test

1. INSPECT THE RIGHT FRONT SIDE MARKER LAMP BULB

Note: If the right front side marker lamp, the right park lamp, the right rear side marker lamp, and the right tail lamp are inoperative, inspect Fuse 7 located in the Illumination Control Module/IP Fuse Block. If the fuse is open, repair the cause of the open fuse before continuing.

Turn the ignition off.

Remove the Right Front Side Marker Lamp bulb and inspect for an open filament.

Is the Bulb filament open?

Yes >> Replace the Right Front Side Marker Lamp bulb. (Refer to 8 - ELECTRICAL/LAMPS/LIGHTING - EXTERIOR/MARKER LAMP - REMOVAL).
Perform BODY VERIFICATION TEST.

No >> Go to 2

2. MEASURE FUSED B(+) CIRCUIT RESISTANCE

Disconnect the Right Front Side Marker Lamp harness connector.

Disconnect the Illumination Control Module harness connector.

Note: Check connectors - Clean/repair as necessary.

Measure the resistance between the Right Front Side Marker Lamp harness connector and the Illumination Control Module harness connector.

Is the resistance below 5.0 ohms?

Yes >> Go to 3

No >> Repair the Fused B(+) circuit for an open between the Right Front Side Marker Lamp and the Illumination Control Module.
Perform BODY VERIFICATION TEST.

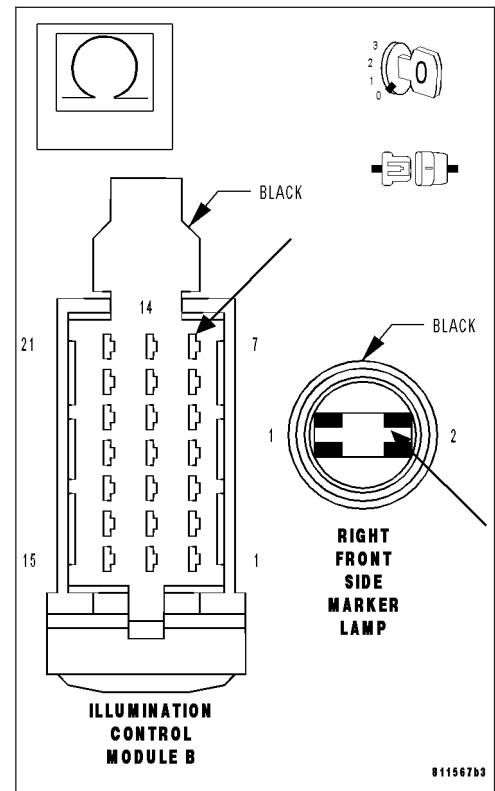

BODY VERIFICATION TEST

BODY VERIFICATION TEST

1.

Turn the ignition off.

Disconnect all jumper wires and reconnect all previously disconnected components and connectors.

Note: If the SKREEM or the PCM was replaced, refer to the service information for proper programming procedures.

If the Body Control Module was replaced, turn the ignition on for 15 seconds (to allow the new BCM to learn VIN) or engine may not start.

Program all RKE transmitters and other options as necessary.

With the DRB III®, erase all Diagnostic Trouble Codes (DTCs) from ALL modules. Start the engine and allow it to run for 2 minutes. Operate all functions of the system that caused the original complaint.

Ensure that all accessories are turned off and the battery is fully charged.

Turn the ignition off and wait 5 seconds. Turn the ignition on and using the DRB III®, read DTCs from ALL modules.

Are any DTCs present or is the original complaint still present?

Are any DTCs present?

YES >> Repair is not complete, refer to appropriate symptom.

NO >> Repair is complete.

REMOVAL - FRONT MARKER LAMP

1. Disconnect the negative battery cable.
2. Insert a trim stick (2) at the rear edge of the front marker lamp lens (1), gently depress forward and lift out from the fascia.
3. Rotate the socket counterclockwise and remove the front marker lamp bulb from the socket.

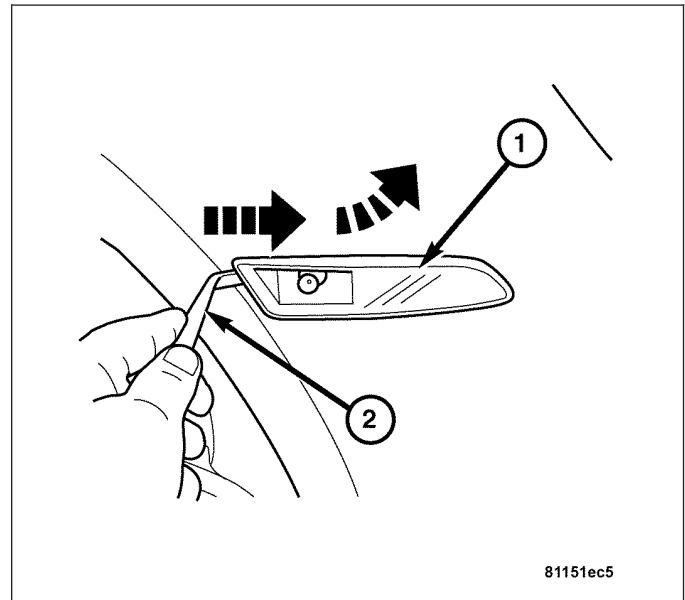

INSTALLATION

INSTALLATION - REAR MARKER LAMP

1. Insert the rear marker bulb into the socket (1) and rotate clockwise into the rear marker lamp lens (2).
2. Install the back edge of the rear marker lamp lens first into the fascia (3), then press the forward edge in at the front.
3. Connect the negative battery cable.

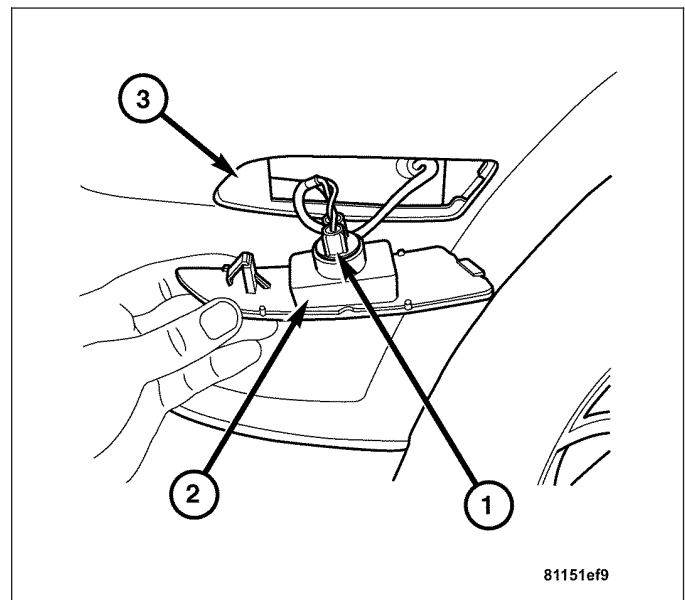

INSTALLATION

1. Install the ashtray lamp into the ashtray lamp harness connector.
2. Connect the ashtray lamp harness connector to the ashtray (1).

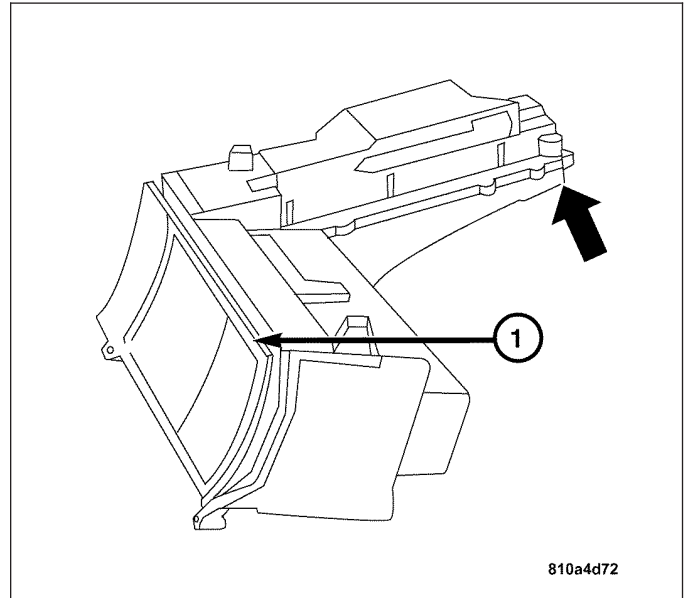

3. Install the ashtray housing (1) to the right and push it toward the left.

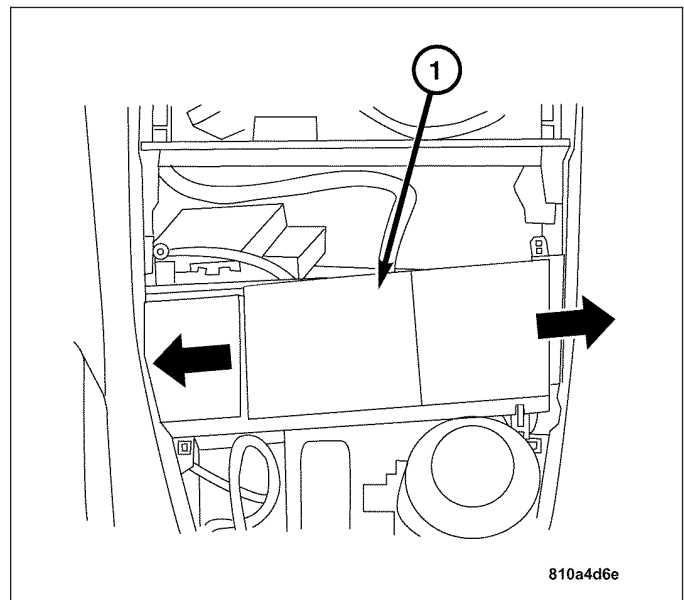

BATTERY REPLACEMENT

The transmitter has two 3 volt batteries, which can be removed and replaced without special tools. First, release the key from the closed position; then insert a coin in the side slot of the transmitter and twist. The cover should separate from the body of the transmitter where the batteries are stacked on top of each other. The batteries are available at local retail stores. Recommended replacement batteries are Panasonic® CR 2025 lithium or equivalent. Battery life for normal use is about two years.

Note: The transmitter MUST be reprogrammed after the batteries are replaced.

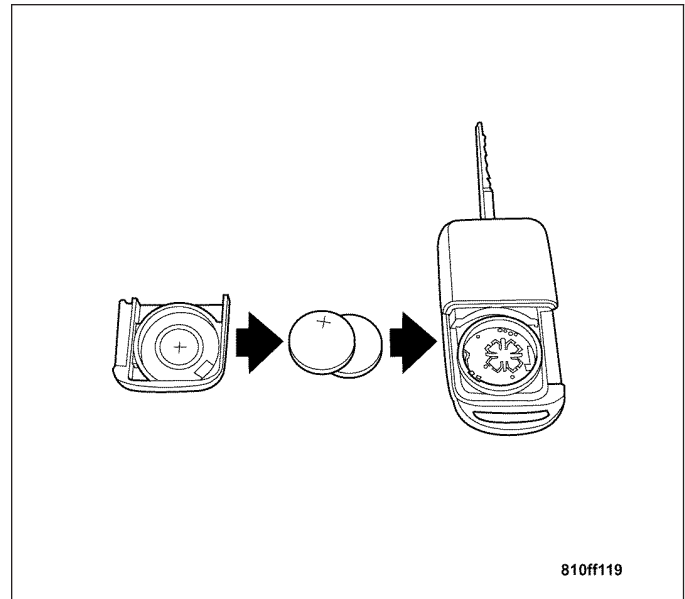

TRANSMITTER RANGE

Operation range is within 20 meters (66 feet) of the module/receiver.

POWER LOCK SWITCH

DESCRIPTION

The mounting arrangement of the power lock switch is unique and integrated with additional switches within the trim panel on the center console. The power lock switch is not serviceable separately. When replacement is necessary, the service part includes additional switches.

REMOVAL

WARNING: REFER TO RESTRAINTS BEFORE ATTEMPTING ANY DOOR, SEAT, STEERING WHEEL, STEERING COLUMN, OR INSTRUMENT PANEL COMPONENT DIAGNOSIS OR SERVICE. FAILURE TO TAKE THE PROPER PRECAUTIONS COULD RESULT IN ACCIDENTAL AIRBAG DEPLOYMENT AND POSSIBLE PERSONAL INJURY. (Refer to 8 - ELECTRICAL/RESTRAINTS - WARNING).

***PASSENGER POWER SEAT INOPERATIVE (CONTINUED)**

POSSIBLE CAUSES
FUSED B(+) CIRCUIT OPEN
PASSENGER POWER SEAT SWITCH GROUND CIRCUIT OPEN
PASSENGER POWER SEAT SWITCH

For a complete Power Seats Circuit Diagram, (Refer to 8 - ELECTRICAL/POWER SEATS - SCHEMATICS AND DIAGRAMS).

Diagnostic Test

1. MEASURE PASSENGER POWER SEAT SWITCH FUSED B(+) CIRCUIT VOLTAGE

Note: Inspect Fuse 21 located in the Underhood Accessory Fuse Block. If the fuse is open, repair the cause of the open fuse before continuing.

Turn the ignition off.

Disconnect the Passenger Power Seat Switch harness connector.

Note: Check connectors - Clean/repair as necessary.

Turn the ignition on.

Measure the voltage of the Fused B(+) circuit at the Passenger Power Seat Switch harness connector.

Is the voltage above 10 volts?

Yes >> Go to 2

No >> Repair the Fused B(+) circuit for an open.
Perform BODY VERIFICATION TEST.

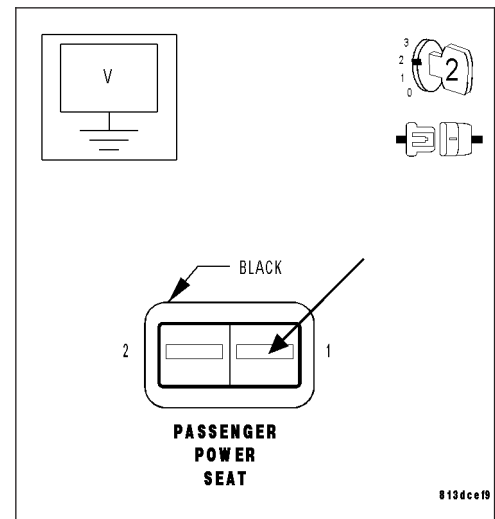

2. MEASURE PASSENGER POWER SEAT SWITCH GROUND CIRCUIT RESISTANCE

Turn the ignition off.

Measure the resistance between ground and the Passenger Power Seat Switch Ground circuit.

Is the resistance below 5.0 ohms?

Yes >> Replace the Passenger Power Seat Switch. (Refer to 8 - ELECTRICAL/POWER SEATS/DRIVER SEAT SWITCH - REMOVAL).
Perform BODY VERIFICATION TEST.

No >> Repair the Ground circuit for an open.
Perform BODY VERIFICATION TEST.

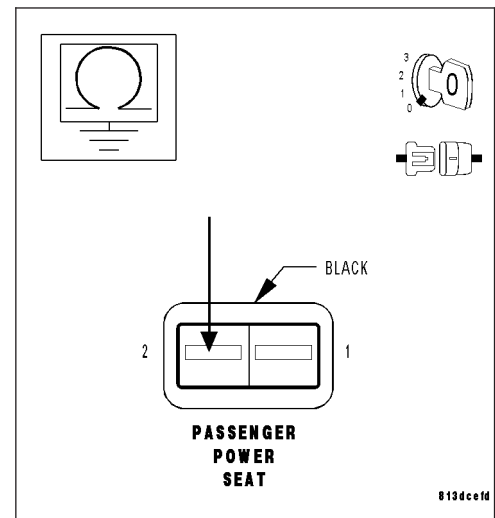

***BOTH POWER WINDOWS INOPERATIVE**

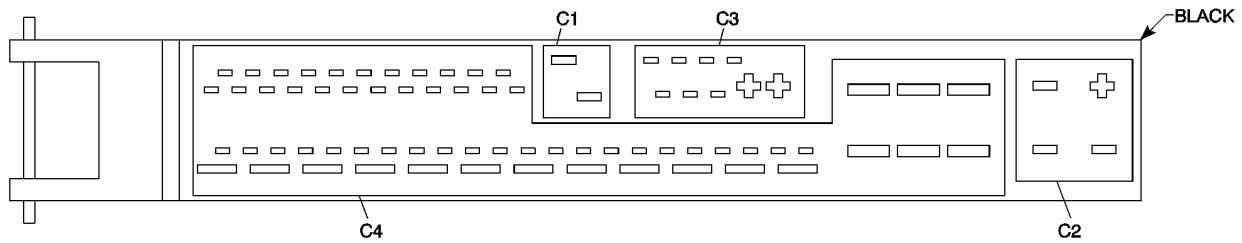
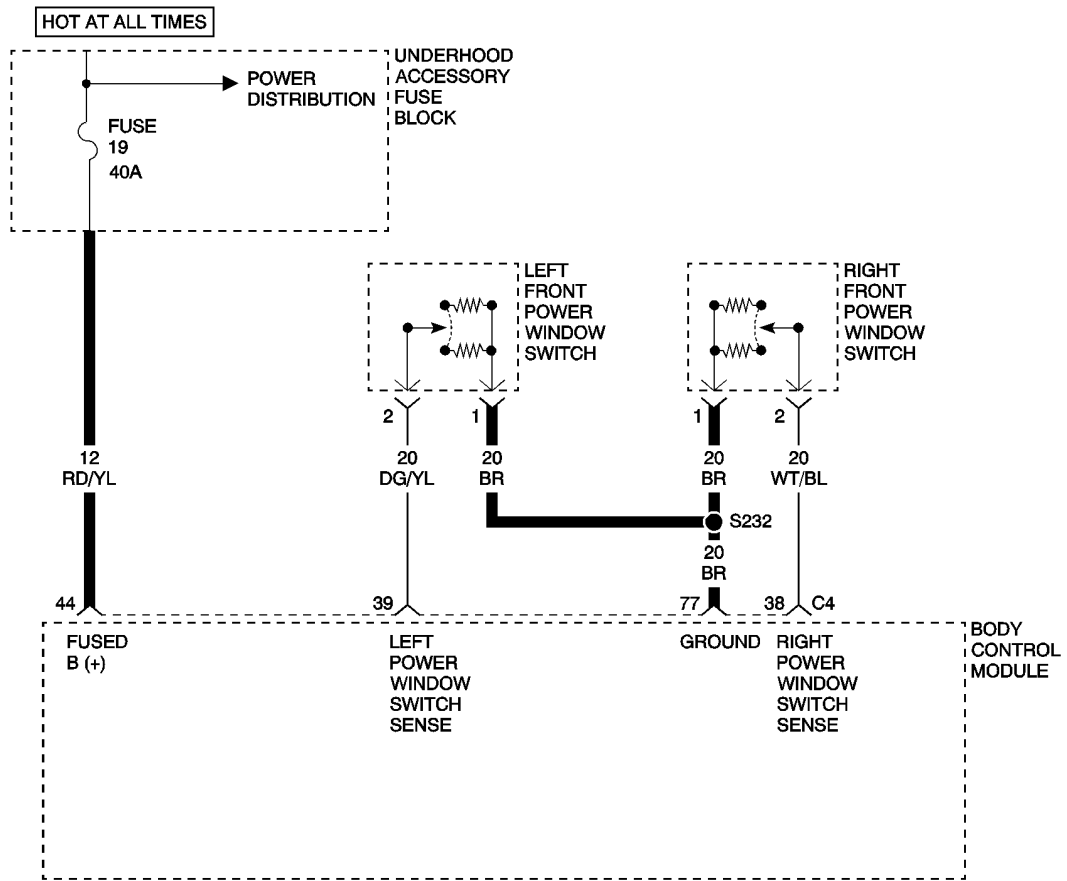

BODY CONTROL MODULE

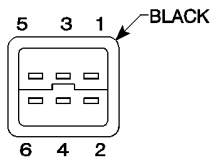

RIGHT FRONT POWER WINDOW SWITCH

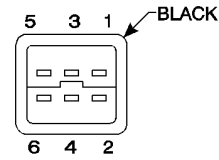

LEFT FRONT POWER WINDOW SWITCH

LEFT SIDE AIRBAG SQUIB CIRCUIT (CONTINUED)

7. MEASURE THE VOLTAGE OF THE LEFT SIDE SQUIB LINE 2 CIRCUIT

With the ignition on.

Measure the voltage of the Left Side Squib Line 2 circuit at the Squib connector.

Is voltage present?

Yes >> Repair the Left Side Squib Line 2 circuit for a short to voltage.

Perform AIRBAG VERIFICATION TEST.

Note: When reconnecting the Airbag System components, the ignition must be turned off and the battery must be disconnected.

No >> Go to 8

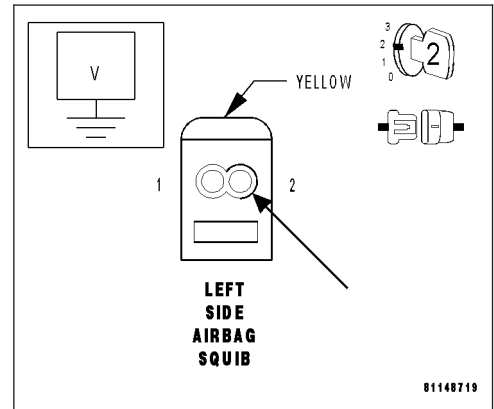

8. MEASURE THE RESISTANCE OF THE LEFT SIDE SQUIB LINE 1 CIRCUIT

WARNING: TURN THE IGNITION OFF, DISCONNECT THE BATTERY AND WAIT TWO MINUTES BEFORE PROCEEDING.

Measure the resistance between ground and the Left Side Squib Line 1 circuit.

Is the resistance below 10K ohms?

Yes >> Repair the Left Side Squib Line 1 circuit for a short to ground.

Perform AIRBAG VERIFICATION TEST.

Note: When reconnecting the Airbag System components, the ignition must be turned off and the battery must be disconnected.

No >> Go to 9

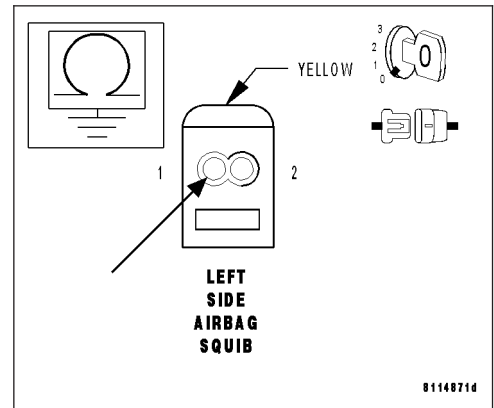

9. MEASURE THE RESISTANCE OF THE LEFT SIDE SQUIB LINE 2 CIRCUIT

With the ignition off.

Measure the resistance between ground and the Left Side Squib Line 2 circuit.

Is the resistance below 10K ohms?

Yes >> Repair the Left Side Squib Line 2 circuit for a short to ground.

Perform AIRBAG VERIFICATION TEST.

Note: When reconnecting the Airbag System components, the ignition must be turned off and the battery must be disconnected.

No >> Replace the Occupant Restraint Controller. (Refer to 8 - ELECTRICAL/RESTRAINTS/OCCUPANT RESTRAINT CONTROLLER - REMOVAL).

WARNING: IF THE OCCUPANT RESTRAINT CONTROLLER IS DROPPED AT ANY TIME, IT MUST BE REPLACED.

Perform AIRBAG VERIFICATION TEST.

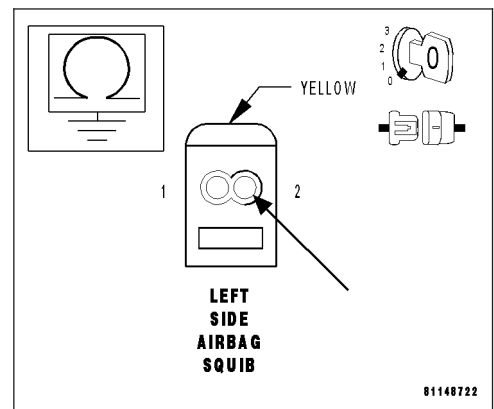

Vehicles with the SRS can also be identified by the Airbag Warning Indicator, which will illuminate in the Instrument Cluster (IC) for about six seconds as a bulb test each time the ignition switch is turned to the "RUN" position.



The Supplemental Restraint System (SRS) also includes the following major components.

Occupant Restraint Controller (ORC) - The Occupant Restraint Controller (ORC) is located on a mount on the top of the transmission tunnel (2) in front of the shifter, under the front center console.

ORC System Logic - The Supplemental Restraint System (SRS) uses an impact severity level (threshold) to determine the appropriate response from the ORC. Impacts that exceed the initial threshold in frontal, front-angled, and rear impacts trigger only the SBT that have the seat belt fastened. If the seat belt is not fastened, the system will not recognize the belt and not trigger the SBT. But, if the impact is severe enough, the airbags will be triggered even if the seat belts are not fastened. Impacts that exceed the higher threshold always trigger the airbags. The driver and passenger SRS systems operate independently of one another based on seat belt use. SBT actuation occurs only if the seat belts are buckled. After an impact that activates an SBT, the SBT assembly must be replaced. The ORC monitors operational readiness of the SRS and illuminates the airbag warning indicator lamp in the Instrument Cluster (IC) if a malfunction should occur.

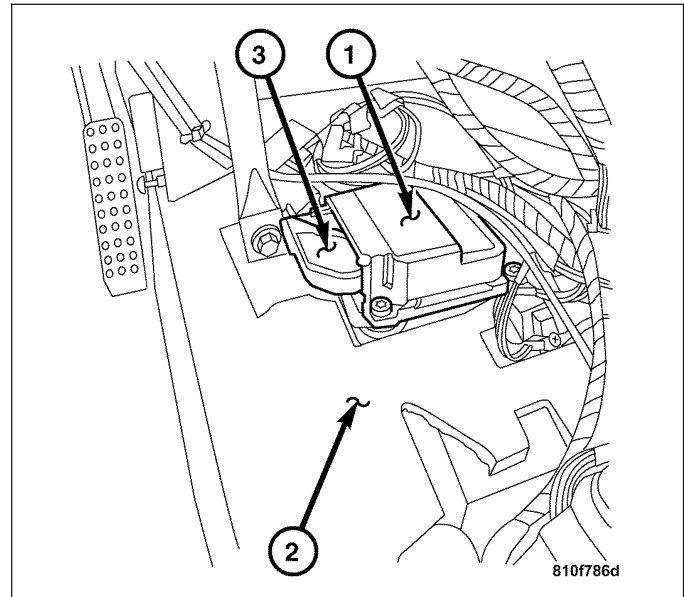

The following system components are monitored or undergo a self-check at startup. The side-impact sensor, airbag ignition circuits (squibs), seat belt buckle switches and the SBT. The airbag warning indicator lamp also illuminates briefly each time the engine is started, allowing the driver to verify its operation.

Note: The carpet is firmly molded, and will need to be propped up while servicing the impact sensor.

14. Disconnect the side impact sensor harness connector.

CAUTION: Use caution when disconnecting the squib connector. Do not pry on the connector insulator to disengage the connector from the side impact sensor. Improper removal of the connector can result in damage to the airbag circuits or connector insulator.

15. Remove the two bolts attaching the side impact sensor (1) to the body cross brace.
16. Remove the side impact sensor from the vehicle.

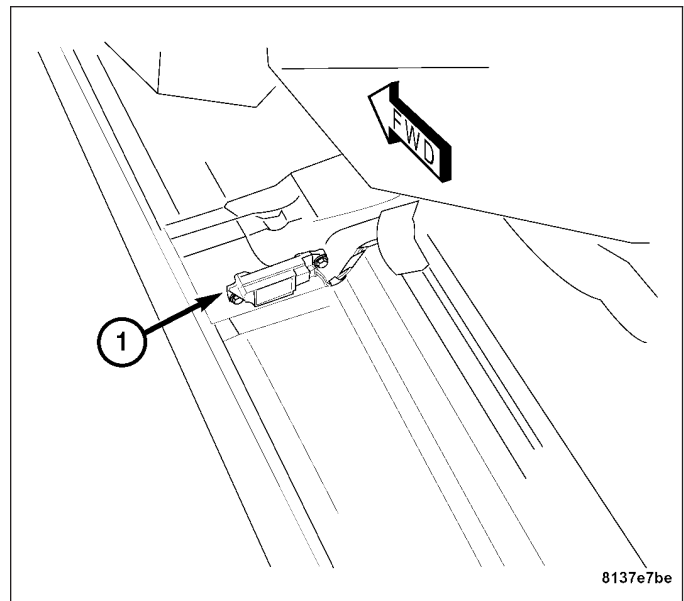

REMOVAL – RIGHT SIDE

1. Before attempting any service procedures refer to the warnings in the beginning of this section. (Refer to 8 - ELECTRICAL/RESTRAINTS - WARNING).
2. Remove the door sill plate.

Note: Pull straight up on the sill plate to release it from the retaining clips.

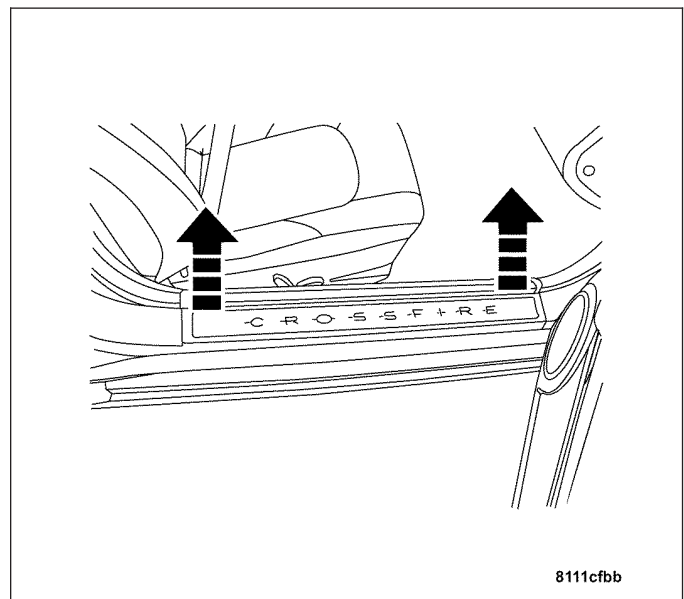

CENTRAL LOCKING PUMP/SECURITY SYSTEM MODULE SYSTEM OVERVOLTAGE (CONTINUED)**When Monitored and Set Condition**

- When Monitored: Ignition on. The Central Locking Pump/Security System Module (CLP/SSM) monitors the Fused B(+) circuit at all times for proper system voltage.
- Set Condition: If the voltage is above 16 volts, the Diagnostic Trouble Code (DTC) is set.

POSSIBLE CAUSES
SYSTEM VOLTAGE HIGH
GROUND CIRCUIT OPEN
CENTRAL LOCKING PUMP/SECURITY SYSTEM MODULE

For a complete Vehicle Theft Security System Circuit Diagram, (Refer to 8 - ELECTRICAL/VEHICLE THEFT SECURITY - SCHEMATICS AND DIAGRAMS).

Diagnostic Test**1. WITH THE DRB III®, READ DTCs**

Turn the ignition on.
 With the DRB III®, erase DTCs.
 Turn the ignition off.
 Turn the ignition on.
 Start the engine.
 With the DRB III®, read DTCs.

Does the DRB III® display a System Overvoltage DTC?

- Yes** >> Go to 2
- No** >> The condition that caused this DTC to set is currently not present. Inspect the related wiring harness for a possible intermittent condition.

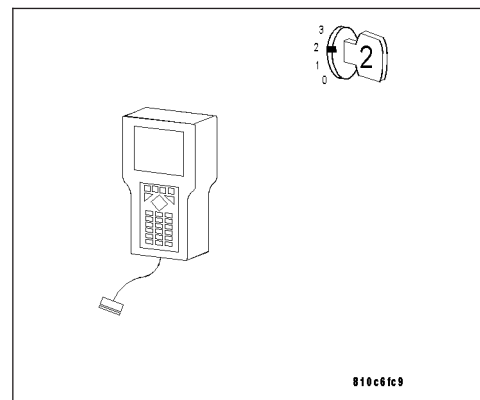
**2. MEASURE THE BATTERY VOLTAGE**

Turn the ignition off.
 Disconnect the CLP/SSM harness connector.

Note: Check connectors - Clean/repair as necessary.

Start the engine.
 Raise the engine speed above 1800 RPM.
 Measure the battery voltage.

Is the voltage above 16 volts?

- Yes** >> Refer to the appropriate service information for charging system testing and repair.
 Perform VTSS VERIFICATION TEST.
- No** >> Go to 3

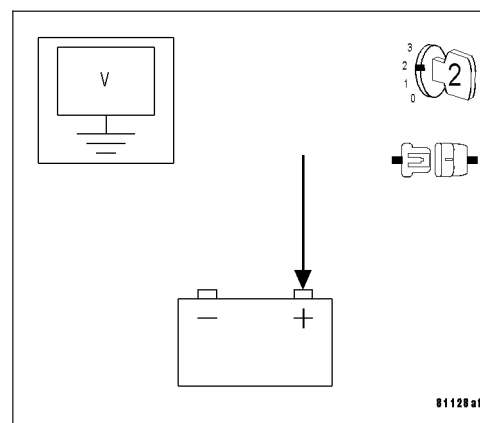

***WIPERS INTERMITTENT SPEED INOPERATIVE (CONTINUED)**

POSSIBLE CAUSES
MULTI-FUNCTION SWITCH
BODY CONTROL MODULE

For a complete Wipers/Washers Circuit Diagram, (Refer to 8 - ELECTRICAL/WIPERS/WASHERS - SCHEMATICS AND DIAGRAMS).

Diagnostic Test**1. MEASURE WIPER SWITCH MUX CIRCUIT VOLTAGE**

Note: If any BCM DTCs are set, diagnose them first before continuing.

Disconnect the Body Control Module (BCM) connector.

Turn the ignition on.

Measure the BCM C3 harness connector cavity 65 for voltage with the Wiper Switch in the Intermittent position.

Is the voltage approximately 12 volts?

- Yes** >> Replace the Body Control Module. (Refer to 8 - ELECTRICAL/ELECTRONIC CONTROL MODULES/BODY CONTROL/CENTRAL TIMER MODUL - REMOVAL).
Perform BODY VERIFICATION TEST.
- No** >> Replace the Multi-Function Switch. (Refer to 8 - ELECTRICAL/LAMPS/LIGHTING - EXTERIOR/MULTI-FUNCTION SWITCH - REMOVAL).
Perform BODY VERIFICATION TEST.

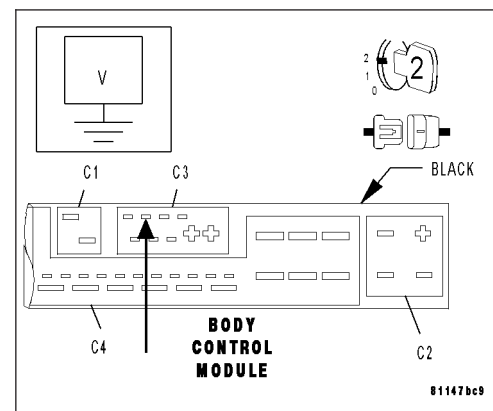

WIRING

TABLE OF CONTENTS

	page		page
WIRING DIAGRAM INFORMATION	8W-01-1	AUDIO SYSTEM	8W-47-1
COMPONENT INDEX	8W-02-1	REAR WINDOW DEFOGGER	8W-48-1
POWER DISTRIBUTION	8W-10-1	TIRE PRESSURE MONITOR	8W-49-1
GROUND DISTRIBUTION	8W-15-1	FRONT LIGHTING	8W-50-1
BUS COMMUNICATIONS	8W-18-1	REAR LIGHTING	8W-51-1
CHARGING SYSTEM	8W-20-1	TURN SIGNALS	8W-52-1
STARTING SYSTEM	8W-21-1	WIPERS	8W-53-1
FUEL/IGNITION SYSTEM	8W-30-1	POWER WINDOWS	8W-60-1
TRANSMISSION CONTROL SYSTEM	8W-31-1	POWER DOOR LOCKS	8W-61-1
VEHICLE SPEED CONTROL	8W-33-1	POWER MIRRORS	8W-62-1
ANTILOCK BRAKES	8W-35-1	POWER SEATS	8W-63-1
VEHICLE THEFT SECURITY SYSTEM	8W-39-1	POWER TOP	8W-66-1
INSTRUMENT CLUSTER	8W-40-1	POWER REAR SPOILER	8W-68-1
HORN/CIGAR LIGHTER	8W-41-1	SPLICE INFORMATION	8W-70-1
AIR CONDITIONING-HEATER	8W-42-1	CONNECTOR PIN-OUTS	8W-80-1
OCCUPANT RESTRAINT SYSTEM	8W-43-1	CONNECTOR/GROUND/SPLICE	
INTERIOR LIGHTING	8W-44-1	LOCATION	8W-91-1
BODY CONTROL MODULE	8W-45-1	POWER DISTRIBUTION	8W-97-1
MESSAGE CENTER	8W-46-1		



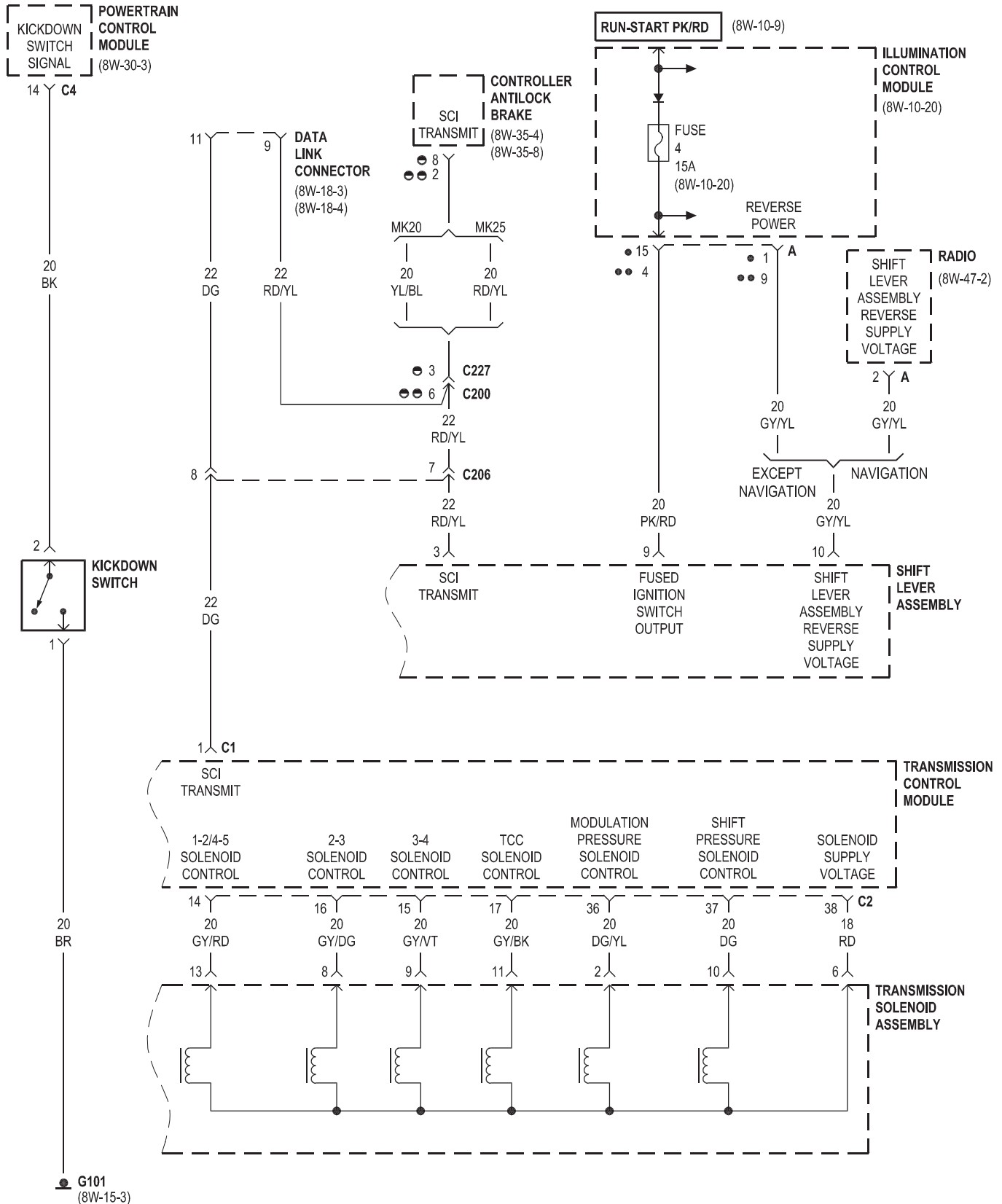

- LHD • MK20
- RHD •• MK25

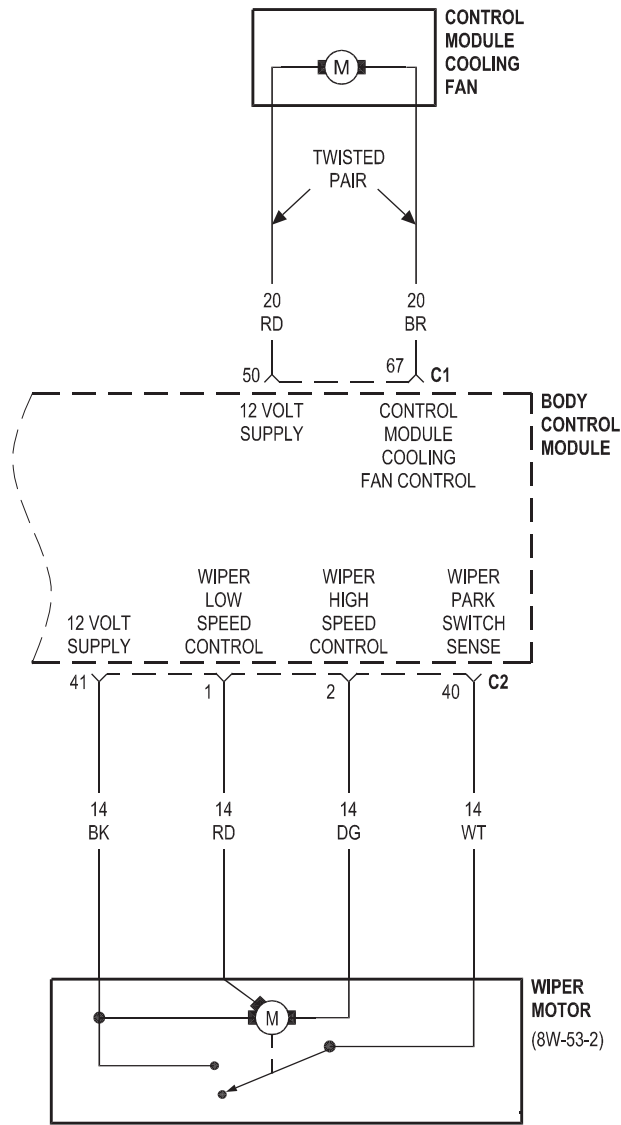

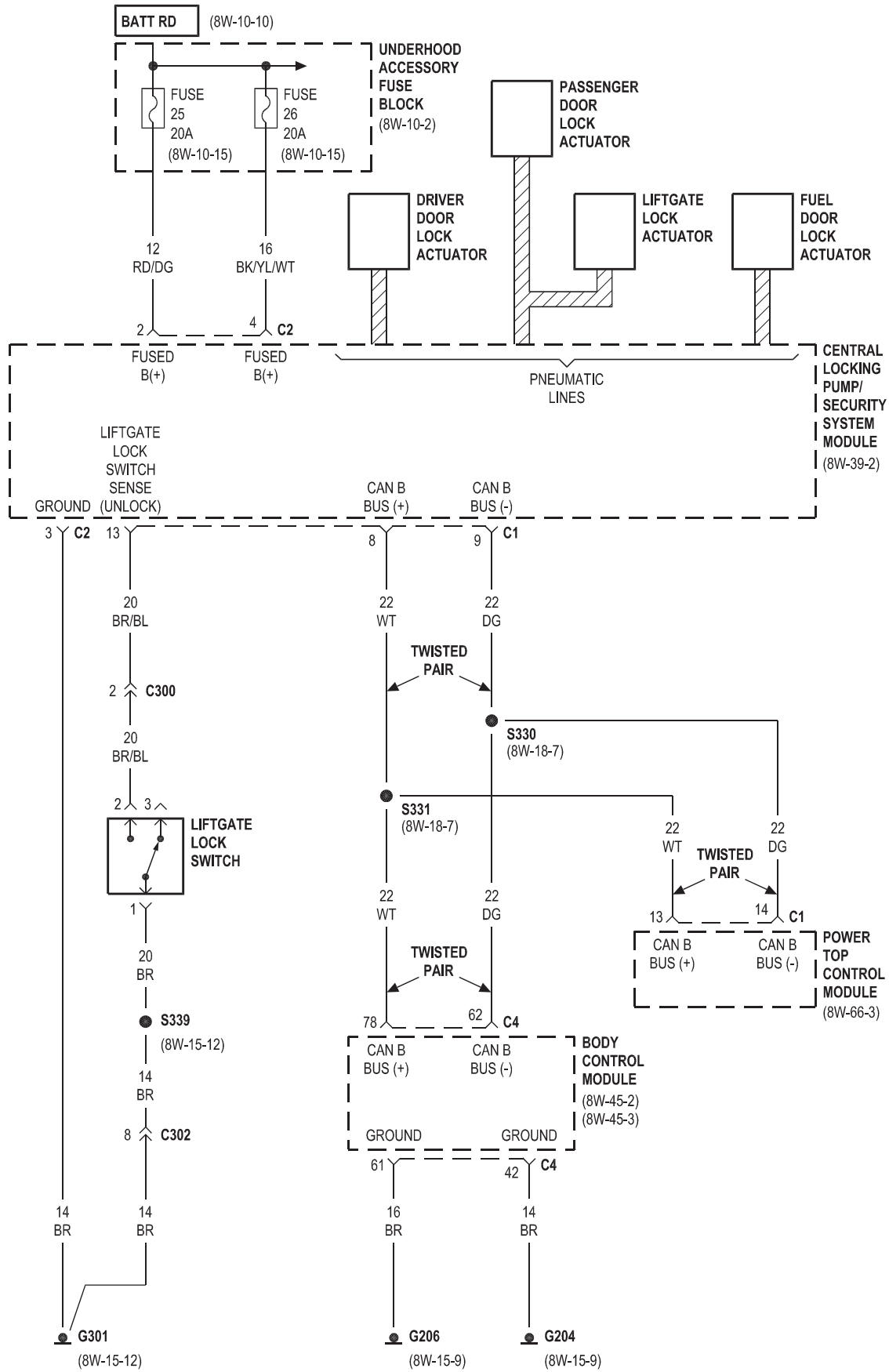

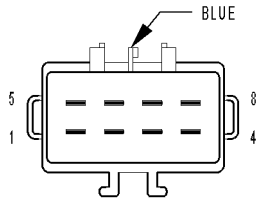

C219

C219 - BLUE (BODY SIDE)

CAV	CIRCUIT
1	20BK/RD (EXCEPT EXPORT)
2	20BR/YL (EXCEPT EXPORT)
3	20DG (EXCEPT EXPORT)
3	18DG/WT (EXPORT)
4	18RD/DG (EXCEPT EXPORT)
5	18BR/BL (EXCEPT EXPORT)
6	20DG/VT (M/T EXCEPT EXPORT)
7	-
8	20BK/BL (ZH27)

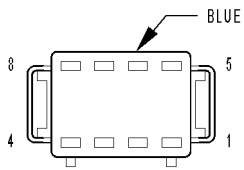

C219

C219 - BLUE (ENGINE COMPARTMENT SIDE)

CAV	CIRCUIT
1	20BK/RD (EXCEPT EXPORT)
2	20BR/YL (EXCEPT EXPORT)
2	20BR/YL (EXCEPT EXPORT)
3	20DG (EXCEPT EXPORT)
3	18DG/WT (EXPORT)
4	18RD/DG (EXCEPT EXPORT)
5	18BR/BL (EXCEPT EXPORT)
6	20DG/VT (M/T EXCEPT EXPORT)
7	-
8	20BK/BL

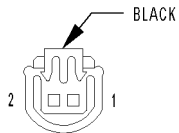

C223

C223 - BLACK (BODY SIDE)

CAV	CIRCUIT
1	20BL/RD
2	20BL/GY

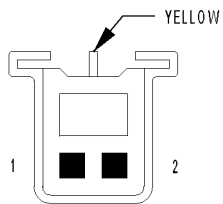

C223

C223 - YELLOW (DOOR SIDE)

CAV	CIRCUIT
1	20BL/RD
2	20BL/GY

POWERTRAIN CONTROL MODULE C3 - BLACK 52 WAY

CAV	CIRCUIT	FUNCTION
23	20BK (EXCEPT SRT)	OXYGEN SENSOR 2/1 SIGNAL
23	20BK/BR (SRT)	OXYGEN SENSOR 2/1 SIGNAL
24	-	-
25	20BR/YL (EXCEPT SRT)	5 VOLT SUPPLY
26	20DG	CRANKSHAFT POSITION SENSOR SIGNAL 2
27	18GY/BK	FUEL INJECTOR NO. 1 CONTROL
28	18GY/BL	FUEL INJECTOR NO. 4 CONTROL
29	-	-
30	-	-
31	-	-
32	-	-
33	-	-
34	-	-
35	-	-
36	-	-
37	-	-
38	-	-
39	20RD/YL	5 VOLT SUPPLY
40	-	-
41	-	-
42	-	-
43	-	-
44	18GY	COIL ON PLUG DRIVER NO. 6
45	18DG	COIL ON PLUG DRIVER NO. 3
46	18BL	COIL ON PLUG DRIVER NO. 4
47	18BK	COIL ON PLUG DRIVER NO. 1
48	-	-
49	18VT	COIL ON PLUG DRIVER NO. 5
50	18YL	COIL ON PLUG DRIVER NO. 2
51	-	-
52	-	-

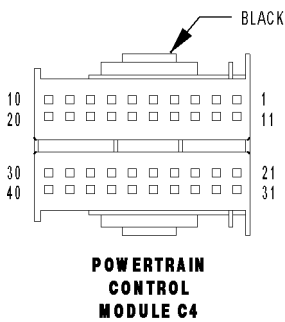

POWERTRAIN CONTROL MODULE C4 - BLACK 40 WAY

CAV	CIRCUIT	FUNCTION
1	22WT	CAN C BUS (+)
2	-	-
3	20GY/YL (EXCEPT SRT)	BACKUP LAMP SWITCH OUTPUT
4	20RD/BK (M/T)	CLUTCH PEDAL POSITION SWITCH SIGNAL
5	18BR	SENSOR GROUND
6	22BK (MK20)	SENSOR GROUND
6	20BK (MK25)	SENSOR GROUND
7	22DG (MK20)	ACCELERATOR PEDAL POSITION SENSOR SIGNAL NO. 2
7	20DG (MK25)	ACCELERATOR PEDAL POSITION SENSOR SIGNAL NO. 2
8	22GY (MK20)	ACCELERATOR PEDAL POSITION SENSOR SIGNAL NO. 1
8	20GY (MK25)	ACCELERATOR PEDAL POSITION SENSOR SIGNAL NO. 1
9	-	-
10	20BR/YL	SENSOR GROUND
11	22DG	CAN C BUS (-)
12	20DG/BK	ENHANCED ACCIDENT REPORT DRIVER
13	-	-
14	20BK (A/T)	KICKDOWN SWITCH SIGNAL

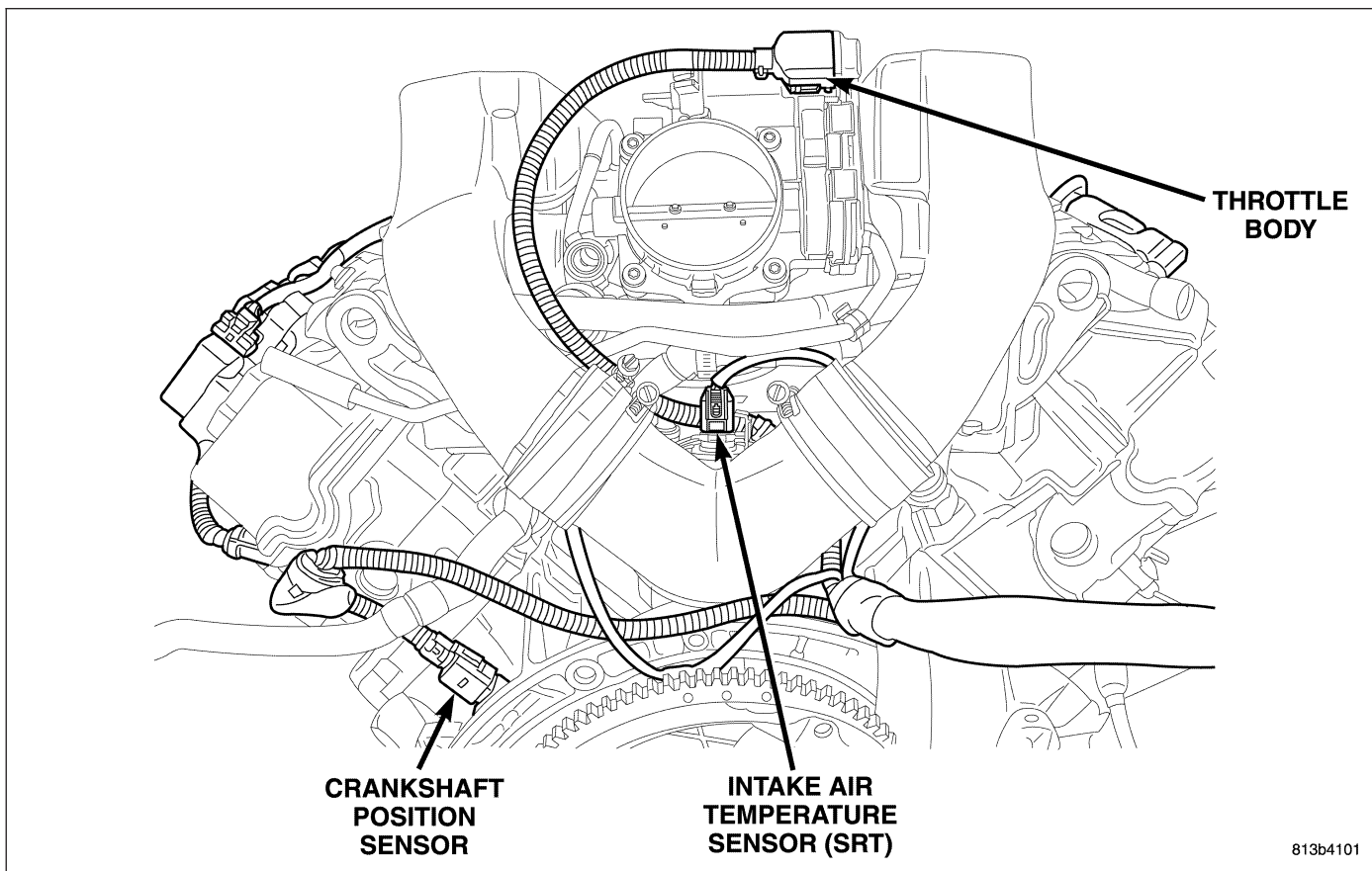

Fig. 21 REAR OF ENGINE (SRT)

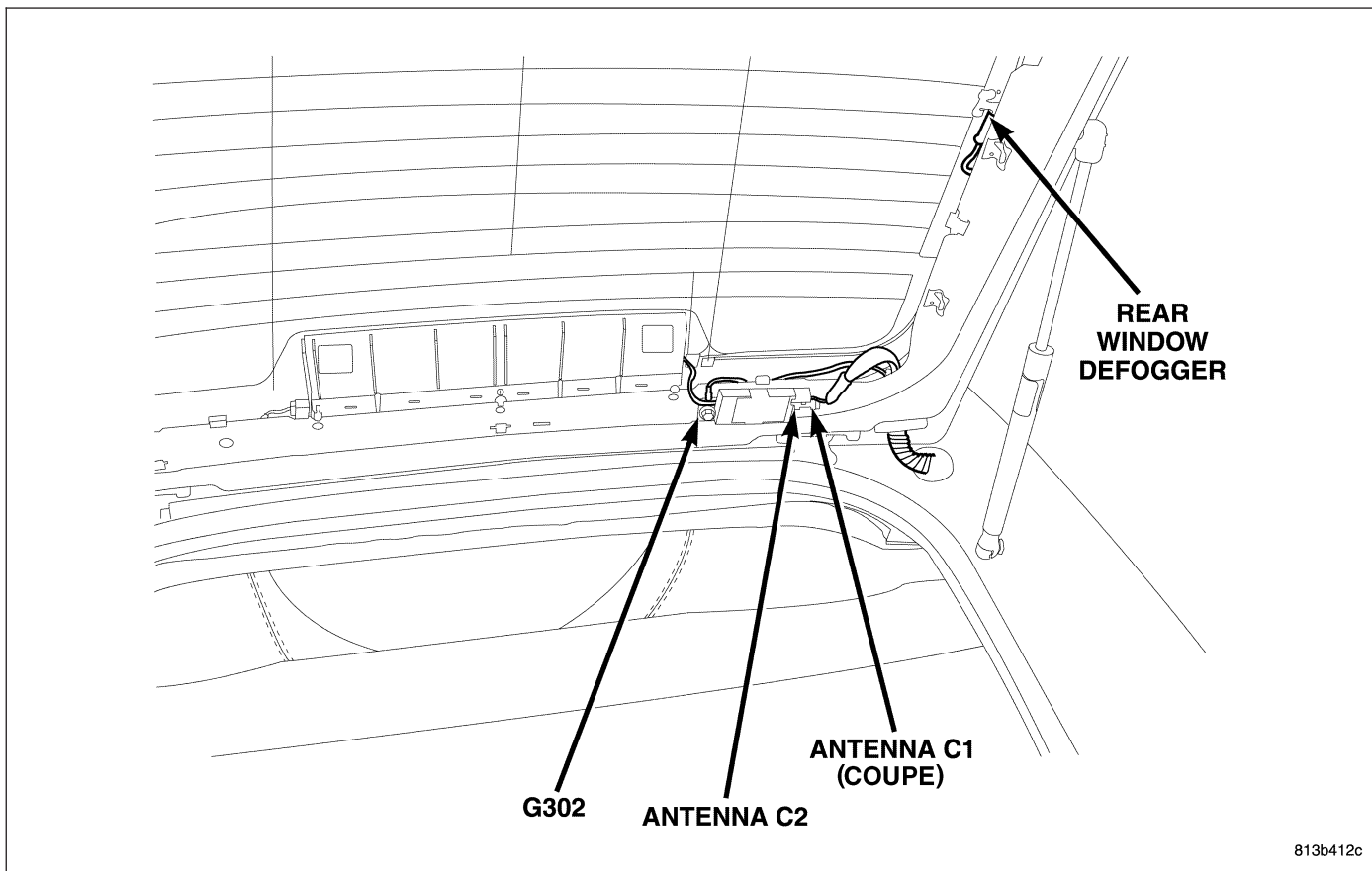

Fig. 22 REAR WINDOW/TRUNK (COUPE)

(P0106) MAP SENSOR PERFORMANCE (CONTINUED)

11. 5-VOLT SUPPLY CIRCUIT SHORT TO SENSOR GROUND CIRCUIT

With the ignition off.

Measure the resistance between the Sensor Ground circuit and the 5-Volt Supply circuit at the MAP Sensor harness connector.

Is the resistance above 100 kohms?

- Yes** >> Replace and program the Powertrain Control Module. (Refer to 8 - ELECTRICAL/ELECTRONIC CONTROL MODULES/POWERTRAIN CONTROL MODULE - REMOVAL).
Perform POWERTRAIN VERIFICATION TEST - VER 2.
- No** >> Repair the 5-Volt Supply circuit for a short to the Sensor Ground circuit.
Perform POWERTRAIN VERIFICATION TEST - VER 2.

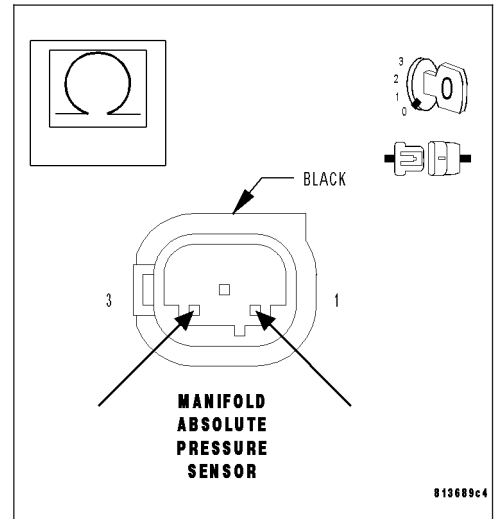

12. MEASURE THE MAP SENSOR SIGNAL CIRCUIT VOLTAGE

Turn the ignition off.

Disconnect the MAP Sensor harness connector.

Note: Check connectors — Clean/repair as necessary.

Turn the ignition on.

Measure the voltage of the MAP Sensor Signal circuit at the MAP Sensor harness connector.

Is the voltage between 4.7 and 5.2 volts?

- Yes** >> Go To 13
- No** >> If the voltage is above 5.2 volts, Go To 15
If the voltage is below 4.7 volts, Go To 17

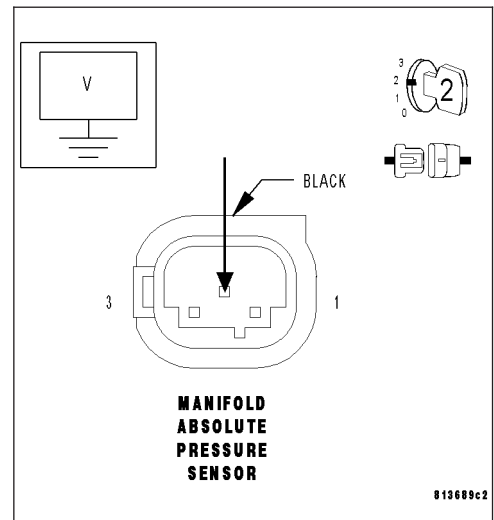

(P0116) ENGINE COOLANT TEMPERATURE SENSOR SHORT CIRCUIT (CONTINUED)**When Monitored and Set Condition**

- When Monitored: With the engine running and no fault in the throttle valve actuator.
- Set Condition: The ECT Sensor value is more than 170°C (338°F) for more than 1 second.

POSSIBLE CAUSES

ENGINE COOLANT TEMPERATURE SENSOR SIGNAL CIRCUIT SHORT TO GROUND
 ENGINE COOLANT TEMPERATURE SENSOR SIGNAL CIRCUIT SHORT TO VOLTAGE
 ENGINE COOLANT TEMPERATURE SENSOR
 POWERTRAIN CONTROL MODULE

For a complete Powertrain Control Module Circuit Diagram, (Refer to 9 - ENGINE - SCHEMATICS AND DIAGRAMS).

Diagnostic Test**1. CHECK FOR CURRENT DTC**

Turn the ignition on.

With the DRB III®, read PCM DTCs.

Is this DTC present?

Yes >> For complete diagnosis of this DTC, refer to (P0116) ENGINE COOLANT TEMPERATURE SENSOR PERFORMANCE.

No >> Go To 2

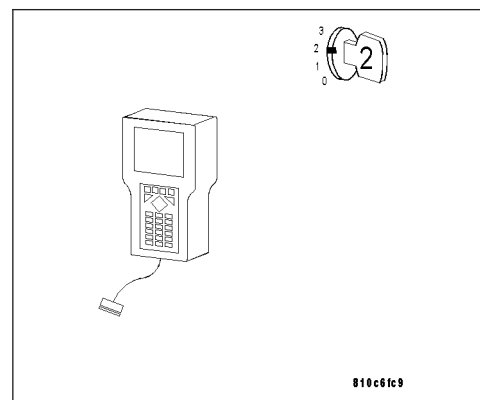
**2. INTERMITTENT WIRING AND CONNECTORS**

The conditions necessary to set this DTC are not present at this time.

Note: Check connectors — Clean/repair as necessary. Poor pin to terminal connections can set DTCs. Using the wiring diagram/schematic as a guide, inspect the wiring and connectors specific to this DTC. Wiggle the wires while checking for shorts and open circuits.

Note: Check for any Technical Service Bulletins that may apply.

Were there any problems found?

Yes >> Repair as necessary.
 Perform POWERTRAIN VERIFICATION TEST - VER 2.

No >> The condition that caused this DTC to set is currently not present. Inspect the related wiring harness for a possible intermittent condition.

(P0128) FORCED LIMITED POWER EXCESSIVE HIGH COOLANT TEMP

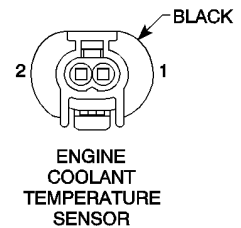
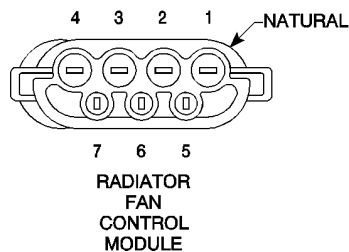
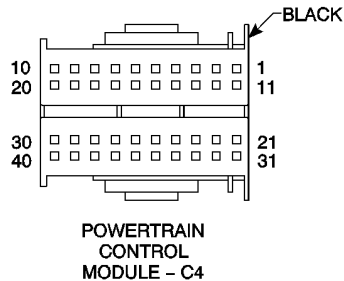
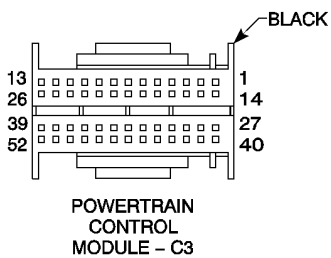
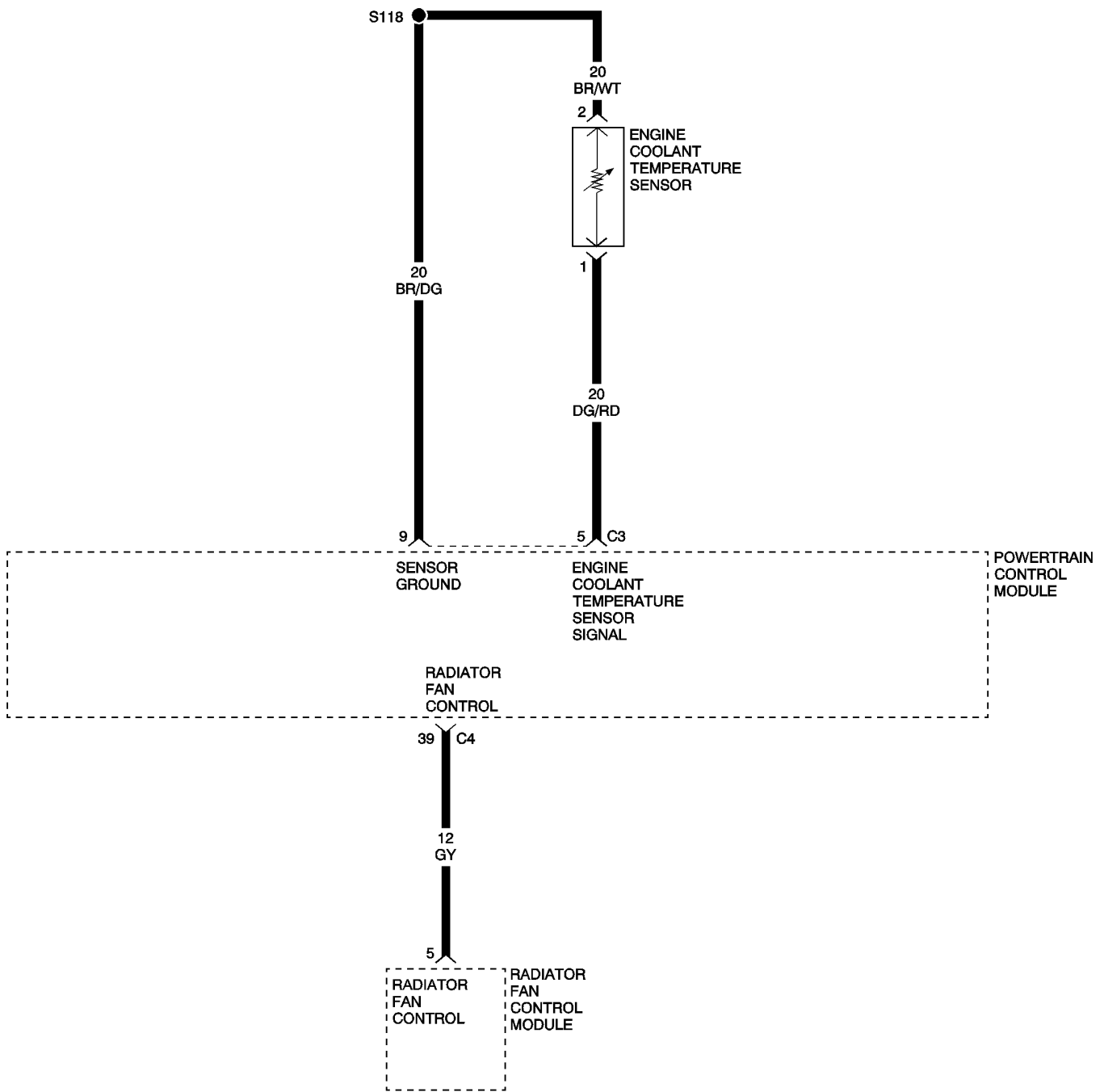

(P0135) O2 SENSOR 1/1 HEATER PERFORMANCE (CONTINUED)**7. FUSED ENGINE CONTROL RELAY OUTPUT CIRCUIT OPEN**

Turn the ignition on.

Measure the voltage of the Fused Engine Control Relay Output circuit at the O2 Sensor harness connector.

Is the voltage above 10 volts?

- Yes** >> Replace the O2 Sensor. (Refer to 14 - FUEL SYSTEM/ FUEL INJECTION/O2 SENSOR - REMOVAL).
Perform POWERTRAIN VERIFICATION TEST - VER 2.
- No** >> Repair the Fused Engine Control Relay Output circuit for an open.
Perform POWERTRAIN VERIFICATION TEST - VER 2.

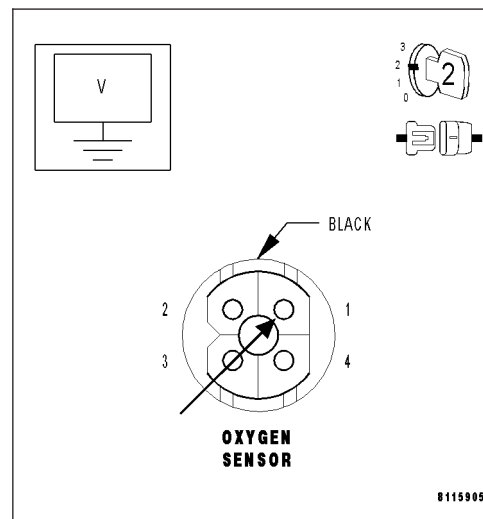
**8. INTERMITTENT WIRING AND CONNECTORS**

The condition that caused this DTC to set is currently not present. Inspect the related wiring harness for a possible intermittent condition.

Note: Check connectors — Clean/repair as necessary. Poor pin to terminal connections can set DTCs.

Note: Check for any Technical Service Bulletins that may apply.

Using the wiring diagram/schematic as a guide, inspect the wiring and connectors specific to this DTC. Wiggle the wires while checking for shorts and open circuits.

Were there any problems found?

- Yes** >> Repair as necessary.
Perform POWERTRAIN VERIFICATION TEST - VER 2.
- No** >> The condition that caused this DTC to set is currently not present. Inspect the related wiring harness for a possible intermittent condition.

CLICK HERE TO **DOWNLOAD** THE COMPLETE MANUAL

- Thank you very much for reading the preview of the manual.
- You can download the complete manual from: www.heydownloads.com by clicking the link below



- Please note: If there is no response to CLICKING the link, please download this PDF first and then click on it.

CLICK HERE TO **DOWNLOAD** THE COMPLETE MANUAL

(P0152) O2 SENSOR 2/1 CIRCUIT HIGH (CONTINUED)

When Monitored and Set Condition

- When Monitored: With the engine running between 1000 and 2000 RPM, engine load between 15% to 50%, closed loop mode, the three way catalytic converter temperature is greater than 380°C (716°F), and the O2 sensor heater must be ON for at least 220 seconds to enable the signal inactive portion of the test.
- Set Condition: O2 Sensor voltage is greater than 1.5 volts for approximately 5 seconds.

POSSIBLE CAUSES
O2 SENSOR SIGNAL CIRCUIT SHORT TO VOLTAGE
ENGINE EXHAUST LEAK
O2 SENSOR
POWERTRAIN CONTROL MODULE

For a complete Powertrain Control Module Circuit Diagram, (Refer to 9 - ENGINE - SCHEMATICS AND DIAGRAMS).

Diagnostic Test

1. CHECK FOR CURRENT DTC

Turn the ignition on.

With the DRB III®, read PCM DTCs.

Is this DTC present?

- Yes** >> For complete diagnosis of this DTC, refer to (P0131) O2 SENSOR 1/1 CIRCUIT LOW.
- No** >> Go To 2

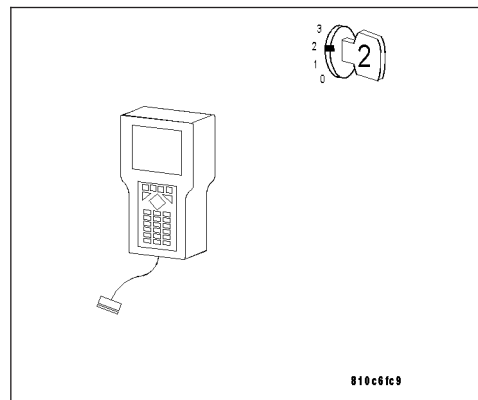

2. INTERMITTENT WIRING AND CONNECTORS

The conditions necessary to set this DTC are not present at this time.

Note: Check connectors — Clean/repair as necessary. Poor pin to terminal connections can set DTCs. Using the wiring diagram/schematic as a guide, inspect the wiring and connectors specific to this DTC. Wiggle the wires while checking for shorts and open circuits.

Note: Check for any Technical Service Bulletins that may apply.

Were there any problems found?

- Yes** >> Repair as necessary.
Perform POWERTRAIN VERIFICATION TEST - VER 2.
- No** >> The condition that caused this DTC to set is currently not present. Inspect the related wiring harness for a possible intermittent condition.

(P0171) FUEL SYSTEM 1/1 RICH CONTROL OVER LIMIT (AT LOAD) (CONTINUED)**9. O2 SENSOR**

Turn the ignition off.

Disconnect the O2 Sensor harness connector.

Note: Check connectors — Clean/repair as necessary.

Turn the ignition on.

With the DRB III®, monitor the O2 Sensor voltage.

The O2 Sensor voltage should read 0.47 volt on the DRB III® with the connector disconnected.

Connect a jumper wire between the O2 Sensor Signal circuit and the Sensor Ground circuit in the O2 Sensor harness connector.

Note: The voltage should drop from 0.47 volt down to 0.0 volt with the jumper wire connected.

Did the O2 Sensor voltage drop from 0.47 volt to 0.0 volt?

Yes >> Replace the Oxygen Sensor. (Refer to 14 - FUEL SYSTEM/FUEL INJECTION/O2 SENSOR - REMOVAL).
Perform POWERTRAIN VERIFICATION TEST - VER 2.

No >> Go To 10

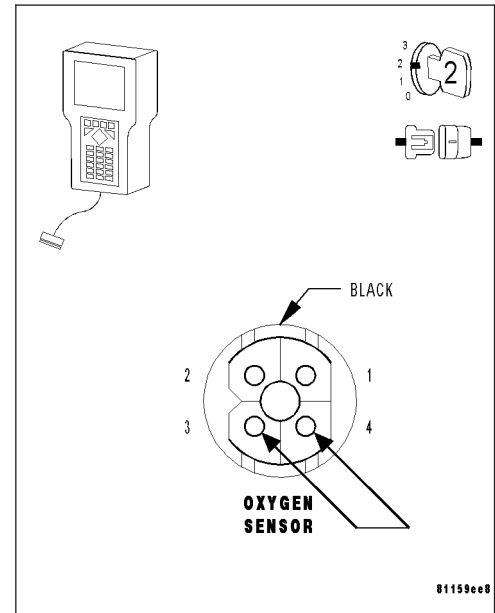
**10. O2 SIGNAL CIRCUIT**

With the ignition on.

Measure the voltage of the O2 Sensor Signal circuit at the O2 Sensor harness connector.

Is the voltage above 0.47 volt?

Yes >> Check the O2 Signal circuit for damage, short to ground, open, or short to voltage. Inspect the O2 Sensor harness connector and the PCM harness connector. If OK, replace the Powertrain Control Module. (Refer to 8 - ELECTRICAL/ELECTRONIC CONTROL MODULES/POWERTRAIN CONTROL MODULE - REMOVAL).
Perform POWERTRAIN VERIFICATION TEST - VER 2.

No >> Go To 11

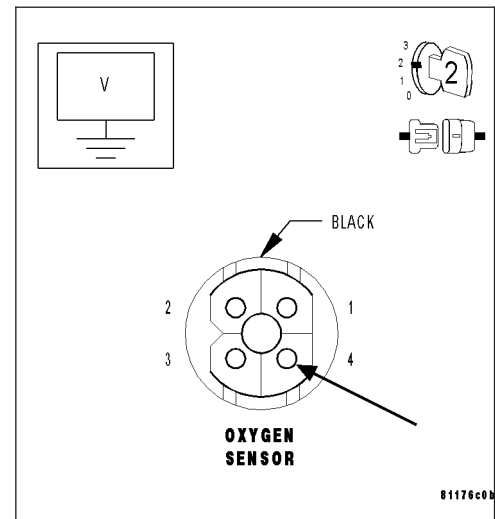

(P0175) FUEL SYSTEM 2/1 LEAN CONTROL BELOW LIMIT (AT IDLE) (CONTINUED)

When Monitored and Set Condition

- When Monitored: With the engine running in closed loop mode, the ambient/battery temperature above -7°C (20°F), altitude below 2590m (8500 ft). and fuel level greater than 15%.
- Set Condition: If the PCM multiplies short term compensation by long term adaptive and a certain percentage is exceeded for two trips, the MIL illuminates and a trouble code is stored.

POSSIBLE CAUSES
RESTRICTED FUEL SUPPLY LINE
FUEL PUMP INLET STRAINER PLUGGED
O2 SENSOR SIGNAL CIRCUIT
O2 SENSOR GROUND CIRCUIT
O2 SENSOR HEATER OPERATION
MANIFOLD ABSOLUTE PRESSURE SENSOR OPERATION
ENGINE COOLANT TEMPERATURE SENSOR OPERATION
ENGINE MECHANICAL PROBLEM
O2 SENSOR
FUEL PUMP
FUEL CONTAMINATION/EXHAUST LEAK

For a complete Powertrain Control Module Circuit Diagram, (Refer to 9 - ENGINE - SCHEMATICS AND DIAGRAMS).

Diagnostic Test

1. CHECK FOR CURRENT DTC

Turn the ignition on.

With the DRB III®, read PCM DTCs.

Is this DTC present?

Yes >> For complete diagnosis of this DTC, refer to (P0172) FUEL SYSTEM 1/1 LEAN CONTROL BELOW LIMIT (AT LOAD).

No >> Go To 2

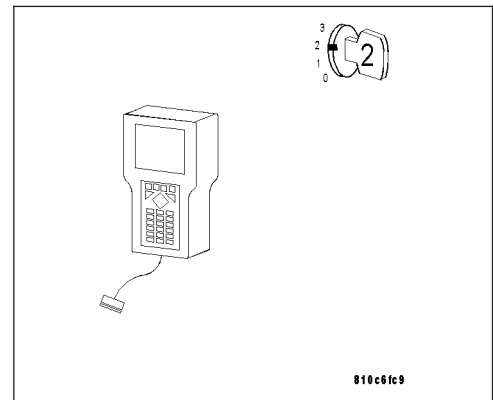

(P0221) ELECTRONIC THROTTLE CONTROL MODULE PROCESSOR

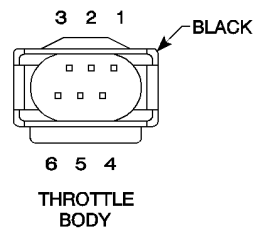
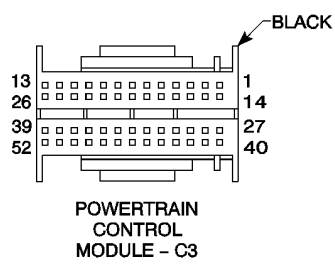
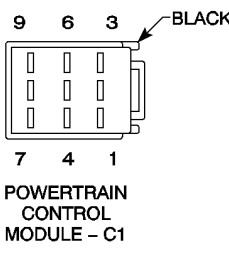
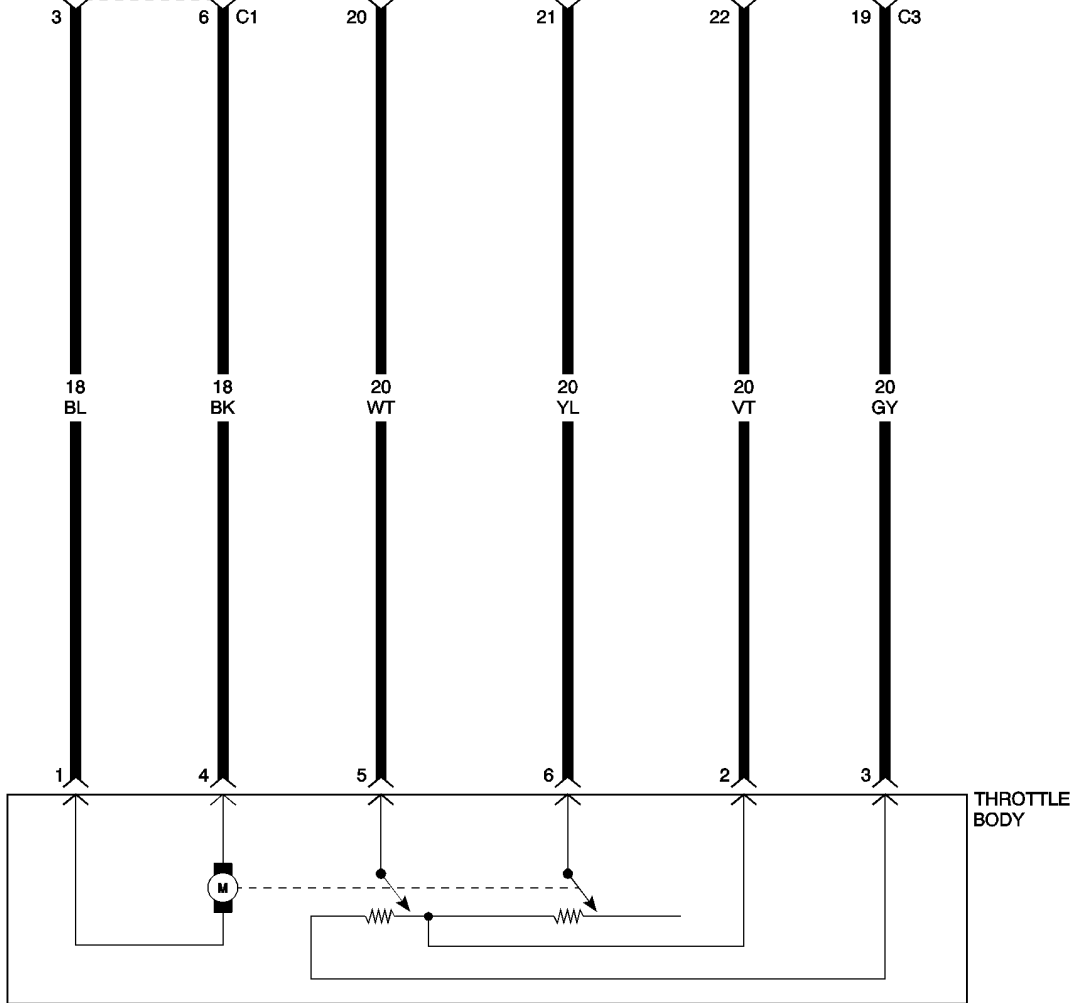
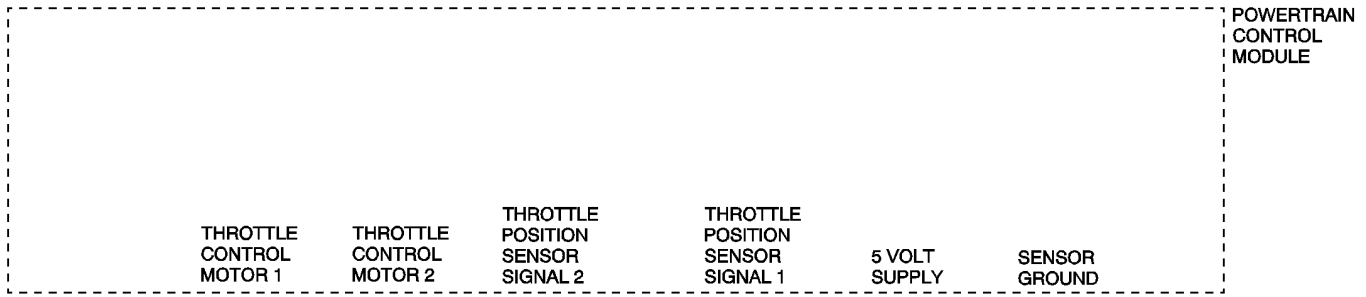

(P0301) CYLINDER #1 MISFIRE (CONTINUED)

8. CHECKING FUEL LEAK DOWN

WARNING: THE FUEL SYSTEM IS UNDER A CONSTANT PRESSURE (EVEN WITH THE ENGINE OFF). BEFORE TESTING OR SERVICING ANY FUEL SYSTEM HOSE, FITTING OR LINE, THE FUEL SYSTEM PRESSURE MUST BE RELEASED.

Note: Before continuing visually and physically inspect the fuel delivery system for external leaks or damage. Repair/replace as necessary.

Turn the ignition off.

Install a substitute fuel pressure hose between the fuel pump and fuel filter.

Start the engine and allow the fuel system to reach maximum pressure.

Turn the ignition off.

Using Special Tool #C4390, Hose Clamp Pliers, slowly clamp off the substitute fuel pressure hose between the fuel pump and the fuel filter.

Monitor the fuel pressure gauge for a minimum of 5 minutes.

Note: The pressure should not fall below 3.0 bar (44 psi) within 5 minutes and should not fall below 2.5 bar (36 psi) within 30 minutes.

Does the fuel pressure gauge fall below the above specification?

Yes >> Replace the leaking component between the Fuel Pump and Injector(s).
Perform POWERTRAIN VERIFICATION TEST - VER 2.

No >> Go To 9

Note: Remove the hose clamp pliers before continuing with test.

9. ENGINE CONTROL RELAY OUTPUT CIRCUIT

Turn the ignition off.

Disconnect the Fuel Injector harness connector.

Note: Check connectors — Clean/repair as necessary.

Turn the ignition on.

Using a 12-volt test light connected to ground, probe the Engine Control Relay Output circuit at the Fuel Injector harness connector.

Does the test light illuminate brightly?

Yes >> Go To 10

No >> Repair the Engine Control Relay Output circuit for an open.
Perform POWERTRAIN VERIFICATION TEST - VER 2.

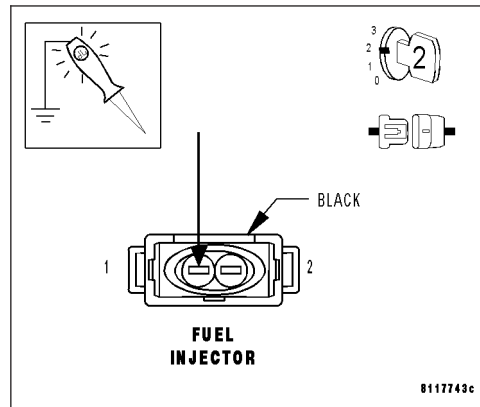

(P0335) CRANKSHAFT POSITION SENSOR CIRCUIT (CONTINUED)**5. CKP SENSOR SIGNAL 2 CIRCUIT VOLTAGE**

With the ignition on.

Measure the voltage of the CKP Sensor Signal 2 circuit at the CKP Sensor harness connector.

Is the voltage between 2.2 and 2.7 volts?

Yes >> Go To 13

No >> Go To 6

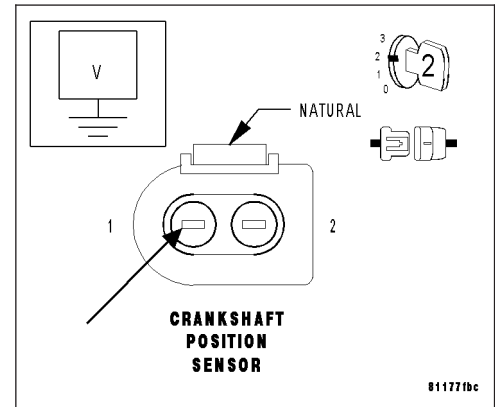
**6. CKP SENSOR SIGNAL 2 CIRCUIT SHORT TO VOLTAGE**

Turn the ignition off.

Disconnect the PCM C3 harness.

Note: Check connectors — Clean/repair as necessary.

Turn the ignition on.

Measure the voltage of the CKP Sensor Signal 2 circuit at the CKP Sensor harness.

Is the voltage below 1.0 volt?

Yes >> Go To 7

No >> Repair the CKP Sensor Signal 2 circuit for a short to voltage.

Perform POWERTRAIN VERIFICATION TEST - VER 2.

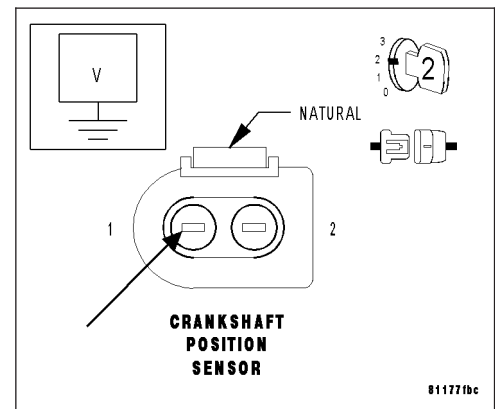
**7. CKP SENSOR SIGNAL 2 CIRCUIT SHORT TO GROUND**

Turn the ignition off.

Measure the resistance between ground and the CKP Sensor Signal 2 circuit.

Is the resistance above 100 kohms?

Yes >> Go To 8

No >> Repair the CKP Sensor Ground circuit for a short to ground.

Perform POWERTRAIN VERIFICATION TEST - VER 2.

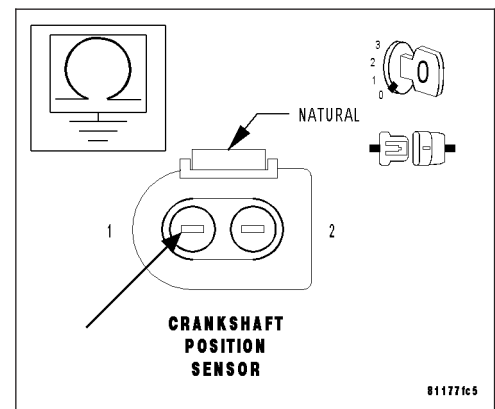

(P0418) SECONDARY AIR INJECTION SYSTEM CONTROL CIRCUIT (CONTINUED)

5. AIR PUMP RELAY CONTROL CIRCUIT SHORT TO THE AIR PUMP RELAY OUTPUT CIRCUIT

Turn the ignition off.

Measure the resistance between the Air Pump Relay Control circuit and the Air Pump Relay Output circuit at the Relay Control Module A harness connector.

Is the resistance above 100 kohms?

Yes >> Replace and program the Powertrain Control Module. (Refer to 8 - ELECTRICAL/ELECTRONIC CONTROL MODULES/POWERTRAIN CONTROL MODULE - REMOVAL).
Perform POWERTRAIN VERIFICATION TEST - VER 2.

No >> Repair the Air Pump Relay Control circuit for a short to the Air Pump Relay Output circuit.
Perform POWERTRAIN VERIFICATION TEST - VER 2.

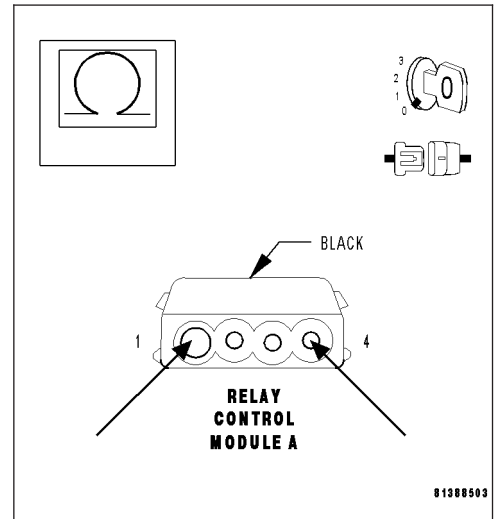

6. AIR PUMP RELAY CONTROL CIRCUIT SHORT TO GROUND

Turn the ignition off.

Disconnect the Relay Control Module A harness connector.

Note: Check connectors — Clean/repair as necessary.

Measure the resistance between ground and the Air Pump Relay Control circuit.

Is the resistance above 100 kohms?

Yes >> Go To 7

No >> Repair the Air Pump Relay Control circuit for a short to ground.
Perform POWERTRAIN VERIFICATION TEST - VER 2.

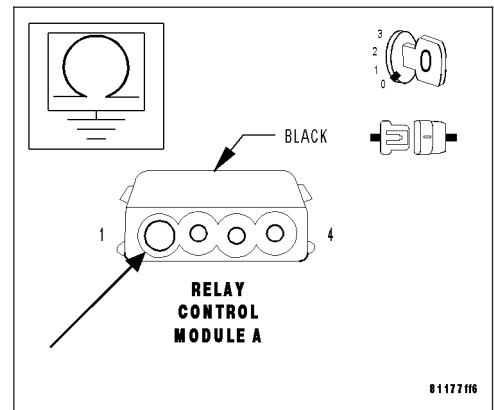

(P0455) EVAP SYSTEM LARGE LEAK

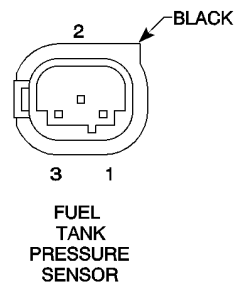
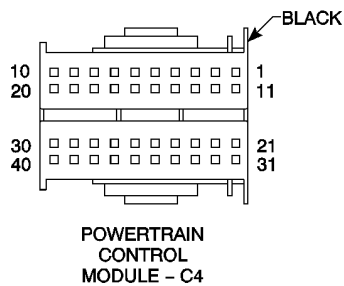
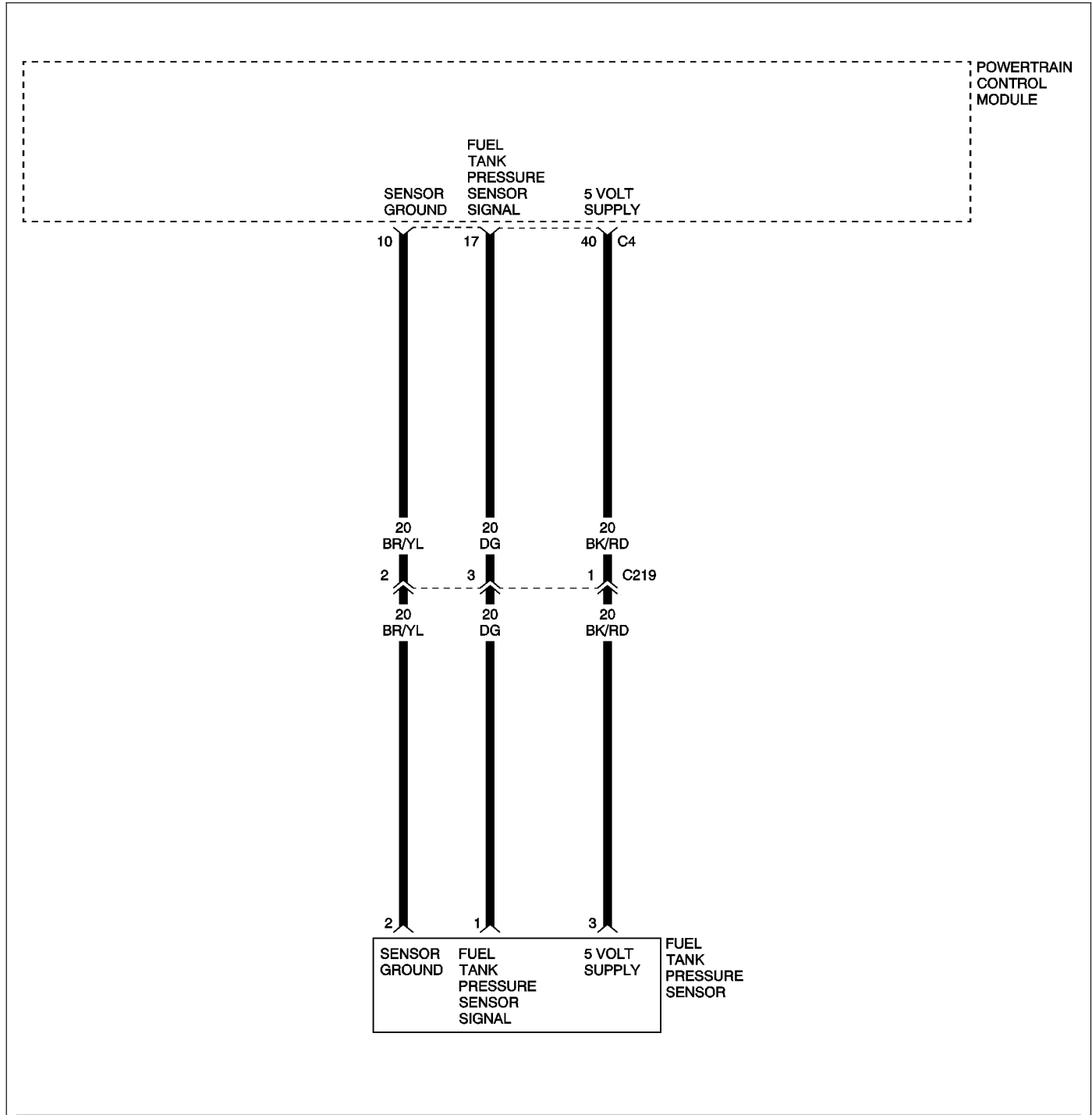

(P0521) ENGINE OIL SENSOR OVER TEMPERATURE (CONTINUED)

7. MEASURE THE 5-VOLT SUPPLY CIRCUIT VOLTAGE

Turn the ignition off.

Disconnect the MAP Sensor harness connector.

Note: Check connectors — Clean/repair as necessary.

Turn the ignition on.

Measure the voltage of the 5-Volt Supply circuit at the Oil Sensor harness connector.

Is the voltage 4.7 – 5.2 volts?

Yes >> Replace and program the Powertrain Control Module. (Refer to 8 - ELECTRICAL/ELECTRONIC CONTROL MODULES/POWERTRAIN CONTROL MODULE - REMOVAL).

Perform POWERTRAIN VERIFICATION TEST - VER 2.

No >> Go To 8

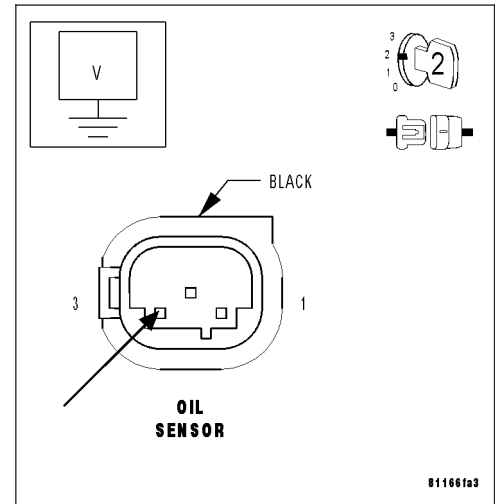

8. MEASURE THE 5-VOLT SUPPLY CIRCUIT VOLTAGE WITH MAP SENSOR DISCONNECTED

Turn the ignition off.

Disconnect the MAP Sensor harness connector.

Note: Check connectors — Clean/repair as necessary.

Turn the ignition on.

Measure the voltage of the 5-Volt Supply circuit at the Oil Sensor harness connector.

Is the voltage 4.7 – 5.2 volts?

Yes >> Replace the Manifold Absolute Pressure Sensor. (Refer to 14 - FUEL SYSTEM/FUEL INJECTION/MAP SENSOR - REMOVAL).

Perform POWERTRAIN VERIFICATION TEST - VER 2.

No >> If the voltage is above 5.2 volts, Go To 9
If the voltage is below 4.7 volts, Go To 10

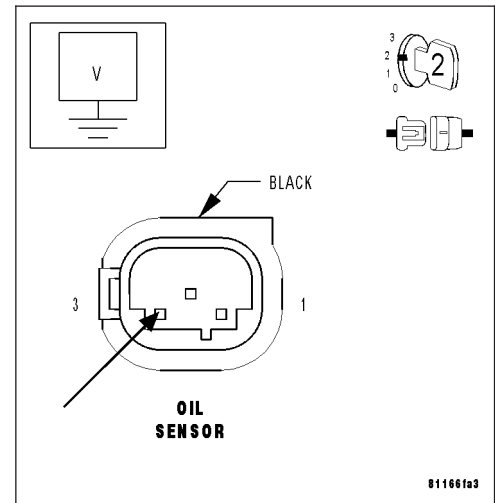

(P0575) SPEED CONTROL SWITCH INPUT CIRCUIT (CONTINUED)**6. FUSED IGNITION SWITCH OUTPUT CIRCUIT OPEN**

Turn the ignition on.

Measure the voltage of the Fused Ignition Switch Output circuit at the Speed Control Switch harness connector.

Is the voltage above 10 volts?

- Yes** >> Replace the Speed Control Switch. (Refer to 8 - ELECTRICAL/SPEED CONTROL/SWITCH - REMOVAL).
Perform POWERTRAIN VERIFICATION TEST - VER 5.
- No** >> Repair the Fused Ignition Switch Output circuit for an open.
Perform POWERTRAIN VERIFICATION TEST - VER 5.

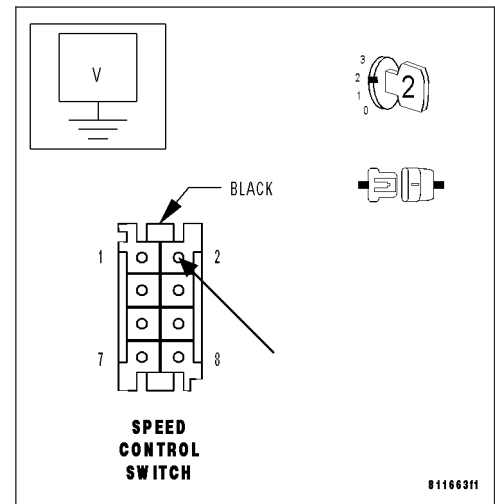
**7. INTERMITTENT WIRING AND CONNECTORS**

The condition that caused this DTC to set is currently not present. Inspect the related wiring harness for a possible intermittent condition.

Note: Check connectors — Clean/repair as necessary. Poor pin to terminal connections can set DTCs.

Using the wiring diagrams as a guide, inspect the wiring and connectors specific to this DTC. Wiggle the wires while checking for shorts and/or open circuits.

Note: Check for any Technical Service Bulletins that may apply.

Were any problems found?

- Yes** >> Repair as necessary.
Perform POWERTRAIN VERIFICATION TEST - VER 2.
- No** >> Test Complete.

(P0702) TCM TORQUE MANAGEMENT REQUEST PERFORMANCE

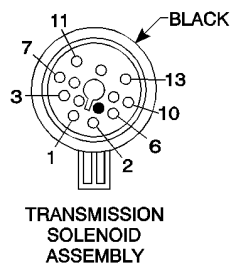
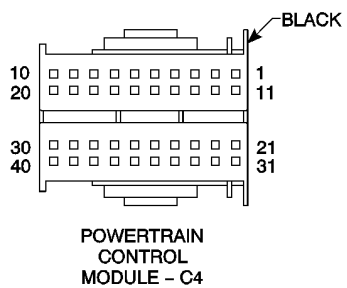

(P1612) MAXIMUM GOVERNOR SPEED DEVIATION - FUEL LIMITING (CONTINUED)**When Monitored and Set Condition**

- When Monitored: Ignition on.
- Set Condition: Just after key on, the throttle is opened and closed to test the system. If the Throttle Position Sensor (TPS) does not quickly exceed a calibrated value this DTC will set. One trip fault.

POSSIBLE CAUSES

THROTTLE PLATE STUCK AT OR BELOW LIMP HOME POSITION
 THROTTLE CONTROL MOTOR 2 CIRCUIT SHORT TO VOLTAGE
 THROTTLE CONTROL MOTOR 1 CIRCUIT OPEN
 THROTTLE CONTROL MOTOR 2 CIRCUIT OPEN
 THROTTLE CONTROL MOTOR 1 CIRCUIT SHORT TO GROUND
 THROTTLE CONTROL MOTOR 2 CIRCUIT SHORT TO GROUND
 THROTTLE BODY
 POWERTRAIN CONTROL MODULE

For a complete Powertrain Control Module Circuit Diagram, (Refer to 9 - ENGINE - SCHEMATICS AND DIAGRAMS).

Diagnostic Test**1. PRE-DIAGNOSTIC CHECK OUT**

Note: Always perform diagnostics with a fully charged battery.

Note: Check connectors — Clean/repair as necessary. Poor pin to terminal connections can set DTCs.

Note: Check for applicable TSBs related to the problem.

Turn the ignition on.

With the DRB III®, read PCM DTCs.

Using the wiring diagram/schematic as a guide, inspect the wiring and connectors. Repair as necessary.

Perform this procedure prior to symptom diagnosis.

Continue

Go To 2

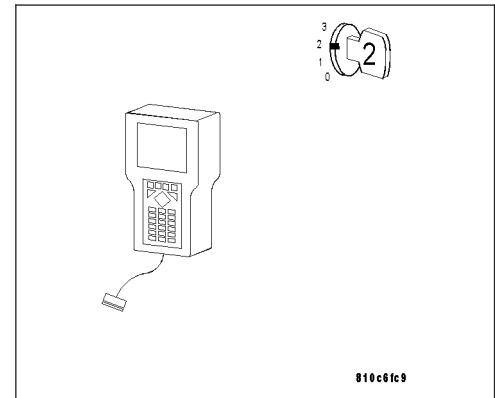

CHECKING HARD START (FUEL SYSTEM) (CONTINUED)*3. CHECKING FUEL PUMP INLET STRAINER**

WARNING: THE FUEL SYSTEM IS UNDER A CONSTANT PRESSURE EVEN WITH THE ENGINE OFF. BEFORE TESTING OR SERVICING ANY FUEL SYSTEM HOSE, FITTING OR LINE, THE FUEL SYSTEM PRESSURE MUST BE RELEASED.

With the ignition off.

Remove and inspect the Fuel Pump Inlet Strainer.

Is the Fuel Pump Inlet Strainer plugged?

- Yes** >> Replace the Fuel Pump Inlet Strainer. (Refer to 14 - FUEL SYSTEM/FUEL DELIVERY/FUEL FILTER - REMOVAL).
Perform POWERTRAIN VERIFICATION TEST - VER 1.
- No** >> Check the Fuel Supply Line for restrictions. Repair as necessary. If OK, replace the Fuel Pump. (Refer to 14 - FUEL SYSTEM/FUEL DELIVERY/FUEL PUMP - REMOVAL).
Perform POWERTRAIN VERIFICATION TEST - VER 1.
-

4. FUEL INJECTOR(S)

WARNING: THE FUEL SYSTEM IS UNDER A CONSTANT PRESSURE EVEN WITH THE ENGINE OFF. BEFORE TESTING OR SERVICING ANY FUEL SYSTEM HOSE, FITTING OR LINE, THE FUEL SYSTEM PRESSURE MUST BE RELEASED.

Start the engine and allow the fuel system to reach maximum pressure.

Turn the ignition off.

Note: Fuel pressure specification is 3.7 to 4.2 bar (54 to 61 psi).

Apply special tool #C-4390, Hose Clamp Pliers, between the fuel pressure gauge and the fuel pump.

Monitor the fuel pressure gauge for a minimum of 5 minutes.

Note: The pressure should not fall below 3.0 bar (44 psi).

Does the fuel pressure drop?

- Yes** >> Replace the leaking fuel injectors. (Refer to 14 - FUEL SYSTEM/FUEL INJECTION/FUEL INJECTOR - REMOVAL).
Perform POWERTRAIN VERIFICATION TEST - VER 1.
- No** >> Check the fuel for contaminants.
Perform POWERTRAIN VERIFICATION TEST - VER 1.
-

19. Connect the power steering pressure (2) and return line (1) to the power steering pump. Tighten the high pressure fitting to 45 N·m (33 ft. lbs.).
20. Connect the ground lead at the power steering pump. Tighten the bolt to 25 N·m (18 ft. lbs.).
21. Refill the power steering pump fluid reservoir.

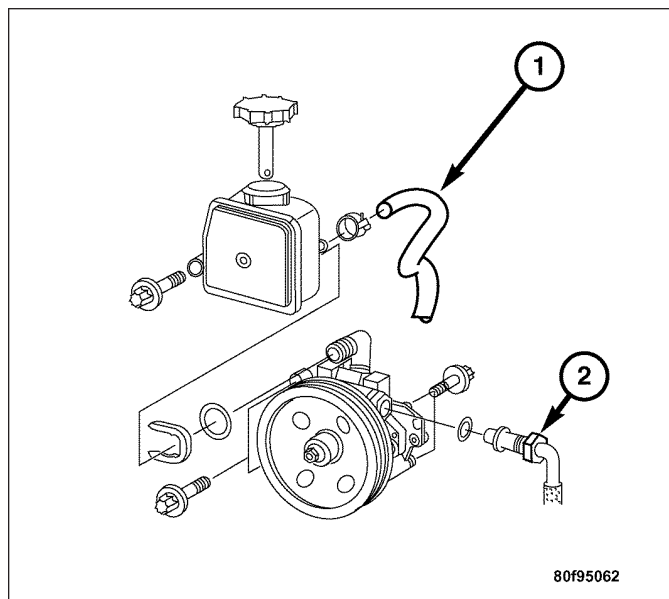

22. Connect the vacuum hoses at the brake booster, intake manifold, and the purge valve.
23. Install the accessory drive belt (Refer to 7 - COOLING/ACCESSORY DRIVE/DRIVE BELTS - INSTALLATION).
24. Install and connect the radiator with the radiator fan (Refer to 7 - COOLING/ENGINE/RADIATOR - INSTALLATION).
25. Install the air cleaner assembly (Refer to 9 - ENGINE/AIR INTAKE SYSTEM/AIR CLEANER HOUSING - INSTALLATION).
26. Connect the negative battery cable.
27. Fill the cooling system (Refer to 7 - COOLING/ENGINE/COOLANT - STANDARD PROCEDURE).
28. Fill the engine with engine oil (Refer to 9 - ENGINE/LUBRICATION/OIL - STANDARD PROCEDURE).
29. Start the engine and check for leaks.
30. Recheck all fluid levels.

SPECIFICATIONS

SPECIFICATIONS - ENGINE

ENGINE SPECIFICATIONS

DESCRIPTION	SPECIFICATION
GENERAL SPECIFICATIONS	
Engine Type	90 ° Bank Angle Liquid Cooled with Dual Tuned Intake Manifold and Twin Ignition
Displacement	3.2 L (195.2 cu. in.)
Bore	89.9 mm (3.54 in.)
Stroke	84 mm (3.31 in.)
Valve System	SOHC 2 Intake and 1 Exhaust Valve per Cylinder Roller Rocker Arms
Compression Ratio	10.0:1
Brake Horsepower	215 (160 KW) @ 5700 rpm (67.2 bhp/liter)
Torque	230 lb. ft. (312 N·m) @ 3000 rpm
Firing Order	1-4-3-6-2-5
Lubrication	Pressure Feed – Full Flow Filtration

- Remove the pistons and connecting rods from top of the engine.

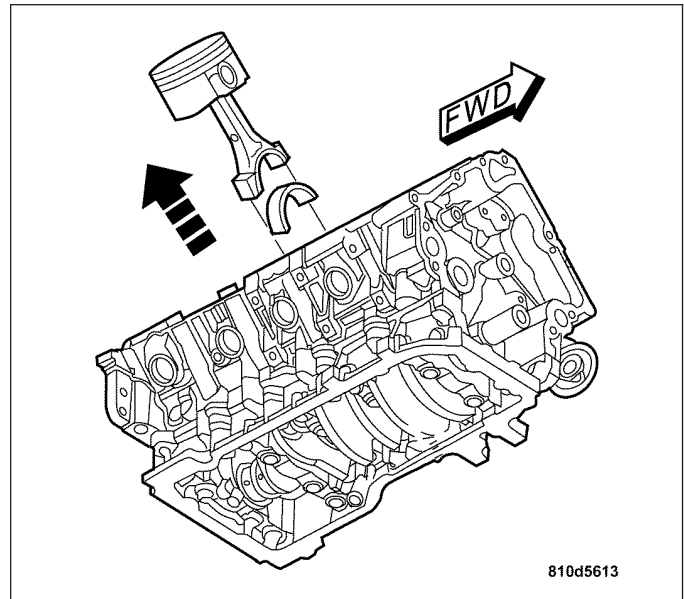

- Perform work on a suitable surface to prevent damage to parts.
- Keep the piston pins matched to the pistons.
- Remove the snap rings from the pistons (2).
- Press out the piston pins (1).
- Remove the piston from the connecting rod (3).
- Inspect all parts to be reused for damage. Replace as required.

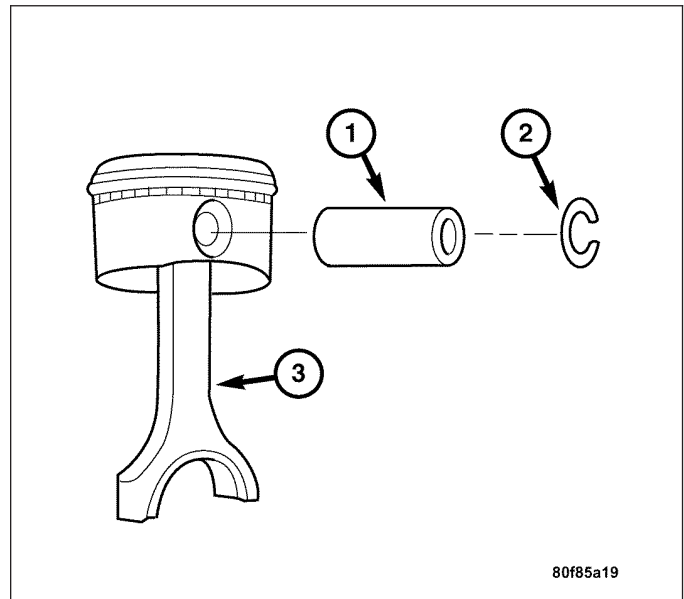

INSPECTION

CONNECTING ROD

- Check the connecting rods for any twisting or bending.
- Check the condition of the large end. Use an oil stone to remove any nicks and burrs.
- Check the condition of the pin bore in the small end of the connecting rod. Use an oil stone to remove all nicks and burrs.

OIL PUMP DRIVE CHAIN

REMOVAL

1. Remove the timing chain cover. (Refer to 9 - ENGINE/VALVE TIMING/GEAR HOUSING COVER - REMOVAL).
2. Remove the oil pump. (Refer to 9 - ENGINE/LUBRICATION/OIL PUMP - REMOVAL).
3. Remove the oil pump drive chain (2) and discard. Inspect the oil pump drive chain tensioner spring for wear and replace as necessary.

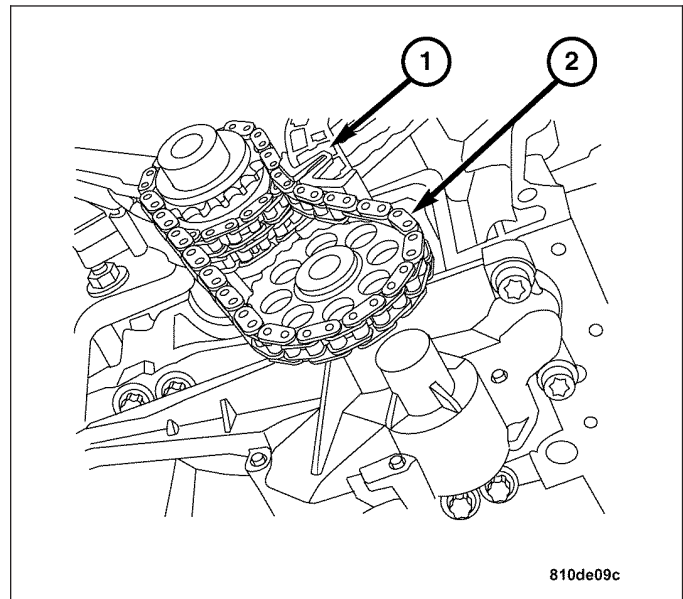

INSTALLATION

1. Check the oil pump drive chain guide for wear and replace as necessary.
2. Install the new oil pump drive chain and the oil pump. (Refer to 9 - ENGINE/LUBRICATION/OIL PUMP - INSTALLATION).
3. Install the timing chain cover. (Refer to 9 - ENGINE/VALVE TIMING/GEAR HOUSING COVER - INSTALLATION).

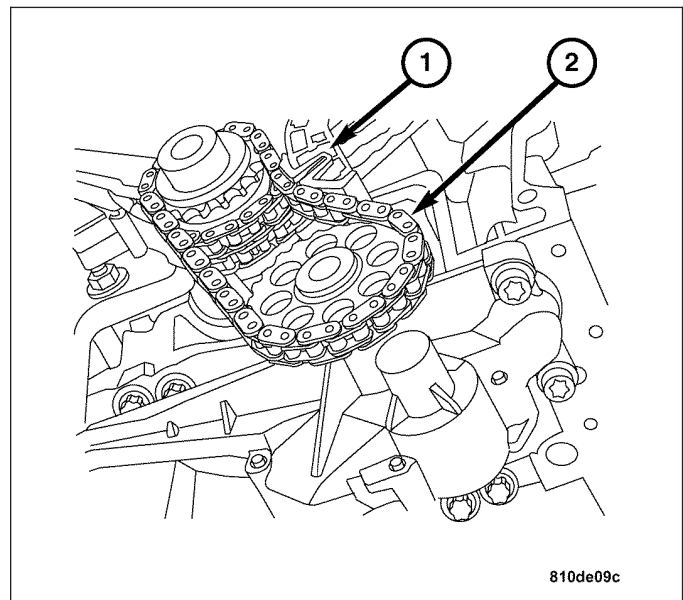

OIL PRESSURE RELIEF VALVE

DESCRIPTION

The oil pressure relief valve cannot be adjusted or repaired. If faulty, worn, or damaged, the entire oil pump assembly must be replaced.

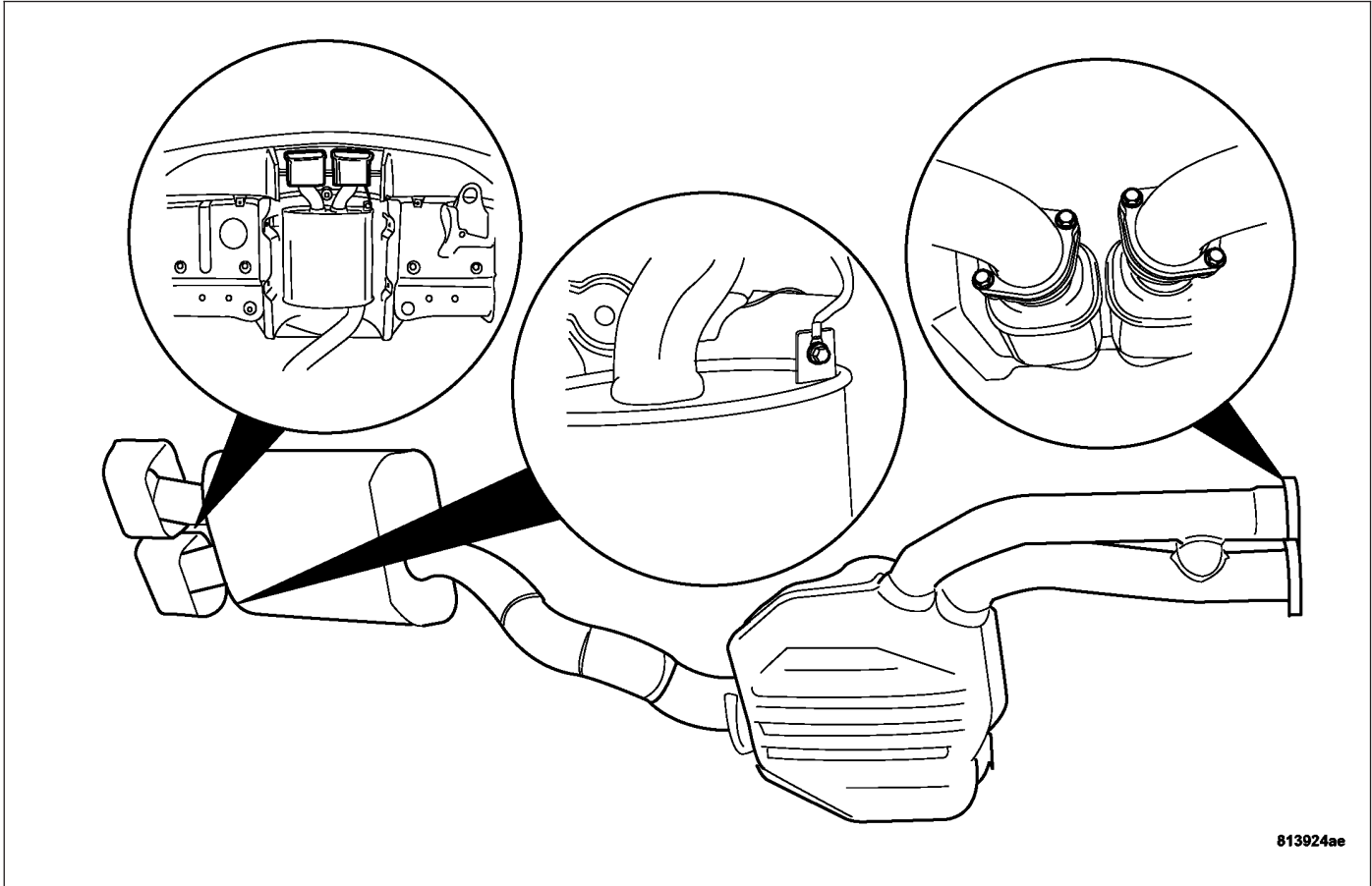
REMOVAL - MUFFLER (SRT)

WARNING: THE NORMAL OPERATING TEMPERATURE OF THE EXHAUST SYSTEM IS VERY HIGH. THEREFORE, NEVER ATTEMPT TO SERVICE ANY PART OF THE EXHAUST SYSTEM UNTIL IT IS COOLED. SPECIAL CARE SHOULD BE TAKEN WHEN WORKING NEAR THE CATALYTIC CONVERTER. THE TEMPERATURE OF THE CONVERTER RISES TO A HIGH LEVEL AFTER A SHORT PERIOD OF ENGINE OPERATION TIME.

1. Raise and support vehicle.
2. Remove the rear support bracket. (Convertible only)(Refer to 13 - FRAME & BUMPERS/FRAME/BRACKET - REMOVAL).
3. Support the rear section of the exhaust system.
4. Remove bolts from the right and left center connection flange.

FUEL INJECTION

TABLE OF CONTENTS

	page		page
FUEL INJECTION		MANIFOLD TUNE VALVE	
SPECIFICATIONS	27	DESCRIPTION	45
ACCELERATOR PEDAL		OPERATION	45
DESCRIPTION	27	REMOVAL	45
REMOVAL		INSTALLATION	46
REMOVAL	28	MAP SENSOR	
REMOVAL - RHD	29	DESCRIPTION	
INSTALLATION		DESCRIPTION	46
INSTALLATION	30	DESCRIPTION - SRT	47
INSTALLATION - RHD	31	OPERATION	
ACCELERATOR PEDAL POSITION SENSOR		OPERATION	47
DESCRIPTION	32	OPERATION - SRT	47
OPERATION	32	REMOVAL	
CRANKSHAFT POSITION SENSOR		REMOVAL	47
DESCRIPTION	33	REMOVAL - SRT	48
OPERATION	33	INSTALLATION	
REMOVAL	34	INSTALLATION	51
INSTALLATION	34	INSTALLATION - SRT	51
FUEL INJECTOR		O2 SENSOR	
DESCRIPTION	35	DESCRIPTION	54
OPERATION	35	OPERATION	54
REMOVAL	36	REMOVAL	
INSTALLATION	37	UPSTREAM O2 SENSOR	56
FUEL PUMP RELAY		REMOVAL - DOWNSTREAM O2	56
DESCRIPTION	38	INSTALLATION	
OPERATION	38	UPSTREAM O2	57
INTAKE AIR TEMPERATURE SENSOR		INSTALLATION - DOWNSTREAM O2	57
DESCRIPTION	38	THROTTLE BODY	
OPERATION	39	DESCRIPTION	58
REMOVAL		OPERATION	58
REMOVAL	39	REMOVAL	
REMOVAL - SRT	39	REMOVAL	58
INSTALLATION		REMOVAL - SRT	59
INSTALLATION	40	INSTALLATION	
INSTALLATION - SRT	41	INSTALLATION	60
MANIFOLD AIR FLOW (MAF) SENSOR		INSTALLATION - SRT	60
DESCRIPTION	42	THROTTLE POSITION SENSOR	
OPERATION	42	DESCRIPTION	61
REMOVAL	43	OPERATION	62
INSTALLATION	44		

DIAGNOSIS AND TESTING - STEERING FLOW AND PRESSURE

The following procedure is used to test the operation of the Power Steering System on the vehicle. This test will provide the Gallons Per Minute (GPM) or flow rate of the Power Steering Pump along with the maximum relief pressure. Perform the test any time a Power Steering System problem is present. This test will determine if the Power Steering Pump or the Power Steering Gear is functioning properly. The following pressure and flow test is performed using the standard shop tool “Power Steering Analyzer Tool Kit #6815” and the “Adapter Kit #6893”.

FLOW AND PRESSURE TEST

1. Check the accessory drive belt to ensure it is in good condition and adjusted properly.
2. Connect the pressure gauge hose (4) from the “Power Steering Analyzer” to the Tube 6865.
3. Connect the Adapter (1) 6826 to the Power Steering Analyzer test valve end.
4. Disconnect the high pressure hose from the power steering pump.
5. Connect the Tube 6865 onto the pump hose fitting.
6. Connect the power steering hose from the steering gear to the Adapter 6826.
7. Open the test valve completely.
8. Start the engine and let it idle long enough to circulate power steering fluid through the flow/pressure test gauge.
9. Shut the engine off and check the fluid level, add fluid as necessary. Start the engine again and let it idle.
10. The initial pressure reading should be 345-552 kPa (50-80 psi). If the pressure is higher inspect the hoses for restrictions and repair as necessary.
11. Increase the engine speed to 1500 RPM and read the flow meter. The reading should be 2.4 - 2.8 GPM. If the reading is below this specification, the pump should be replaced.

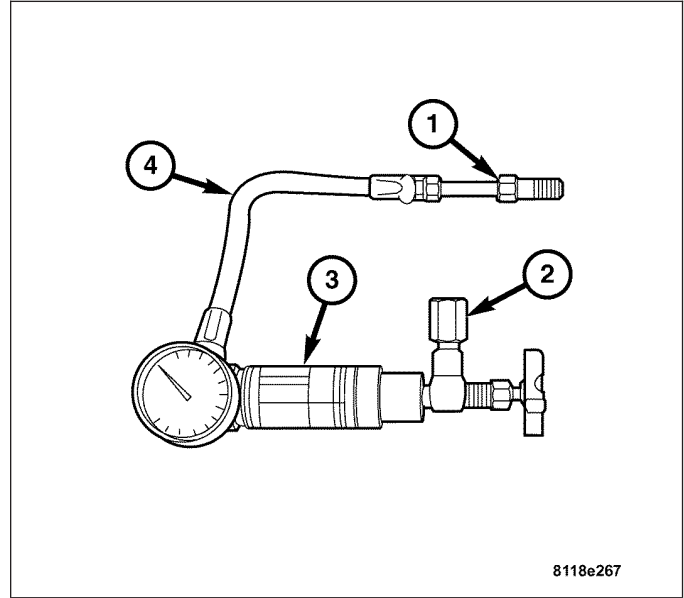

CAUTION: This next step involves testing maximum pump pressure output and flow control valve operation. Do not leave the valve closed for more than three seconds as the pump could be damaged.

12. Close the valve fully three times for three seconds and record the highest pressure indicated each time. **All three readings must be at pump relief pressure specifications and within 345 kPa (50 psi) of each other.**
 - If pressure is above the specifications but not within 345 kPa (50 psi) of each other, replace the pump.
 - If pressure is within 345 kPa (50 psi) of each other but below the specifications, replace the pump.

CAUTION: Do not force the pump to operate against the stops for more than 2 to 4 seconds at a time. Pump damage could result.

13. Open the test valve and turn the steering wheel to the extreme left and right positions against the stops. Record the highest pressure reading at each position. Compare readings to the pump specifications chart. If the pressure readings are not within 50 psi. of each other, the gear is leaking internally and must be repaired.

PUMP FLOW SPECIFICATIONS

DESCRIPTION	SPECIFICATION
FLOW RATE (GPM)	107-115

2. Remove the lower snap ring (4) from the pitman shaft.
3. Remove the pitman arm (3) from the pitman shaft.
4. Remove the upper locking ring (2).
5. Remove the pitman shaft seal (1) from the steering gear housing using a suitable prying tool.

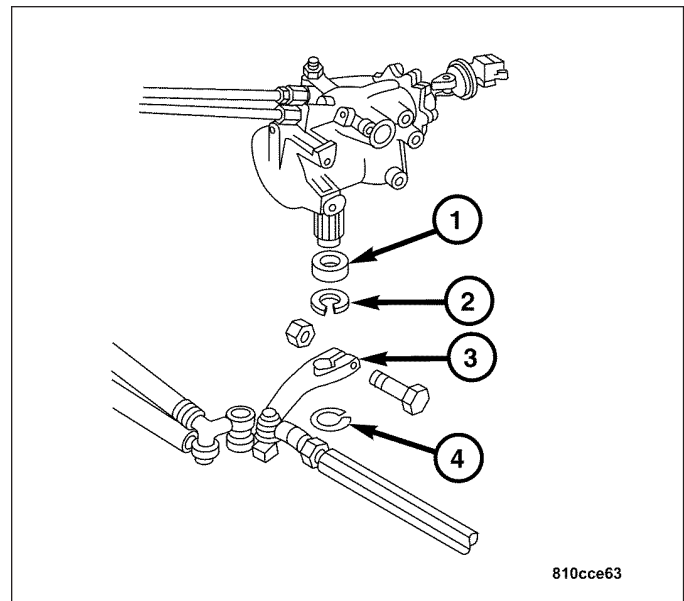

INSTALLATION

CAUTION: DO NOT damage the sealing lip of the pitman shaft seal when sliding it on over the pitman shaft splines.

1. Using Special Tool 9159 Steering Seal Installer (1) install a new pitman shaft seal into the steering gear.

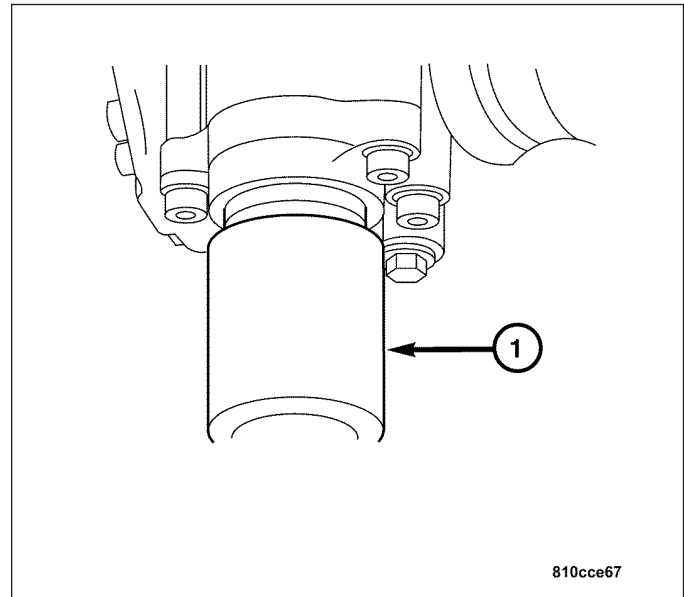

2. Install the upper snap ring (2).
3. Remove any oil and grease from the splined section of the pitman arm, and the pitman arm shaft.
4. Install the lower snap ring (4).

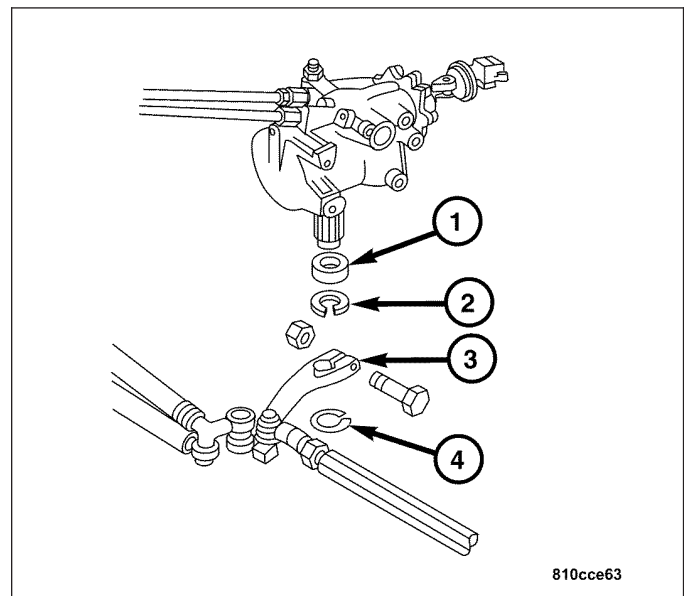

(P0600) ABS CAN MESSAGE INCORRECT (CONTINUED)**2. CONTROLLER ANTILOCK BRAKE**

Turn the ignition off.

Replace the Controller Antilock Brake. (Refer to 8 - ELECTRICAL/ELECTRONIC CONTROL MODULES/CONTROLLER ANTILOCK BRAKE - REMOVAL).

Turn the ignition on.

With the DRB III®, erase Transmission DTCs.

Start the engine and with the brakes firmly applied place the gear selector into Drive.

With the DRB III®, read Transmission DTCs.

Did DTC (P0600) ABS CAN MESSAGE INCORRECT set again?

Yes >> Replace the Transmission Control Module. (Refer to 8 - ELECTRICAL/ELECTRONIC CONTROL MODULES/TRANSMISSION CONTROL MODULE - REMOVAL).
Perform NAG1 TRANSMISSION VERIFICATION TEST.

No >> Test Complete.

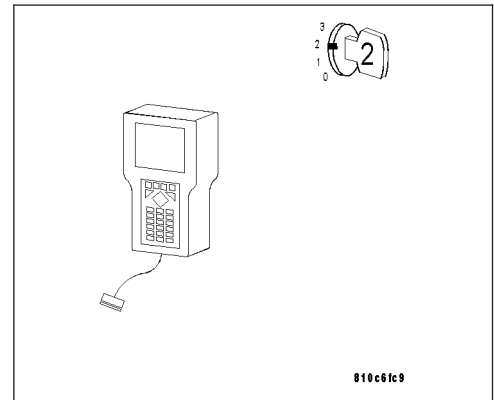

(P0600) IC CAN MESSAGE INCORRECT (CONTINUED)**When Monitored and Set Condition**

- When Monitored: IC CAN-ID received at least once and CAN BUS Circuit DTC is not active.
- Set Condition: CAN message received from the Instrument Cluster is incorrect.

POSSIBLE CAUSES
CAN BUS CIRCUIT DTC PRESENT
INSTRUMENT CLUSTER DTCS PRESENT
CAN C BUS CIRCUIT OPEN
INSTRUMENT CLUSTER

For a complete Transmission Control Module Circuit Diagram, (Refer to 21 - TRANSMISSION/TRANSAXLE/AUTOMATIC - NAG1 - SCHEMATICS AND DIAGRAMS).

For a complete CAN BUS Circuit Diagram, (Refer to 8 - ELECTRICAL/ELECTRONIC CONTROL MODULES - SCHEMATICS AND DIAGRAMS).

Diagnostic Test**1. PRE-DIAGNOSTIC CHECK OUT**

Note: Low fluid level can be the cause of many transmission problems. If the fluid level is low, locate and repair the leak, then check and adjust the fluid level in accordance with the Service Information.

Note: Always perform diagnostics with a fully charged battery to avoid false symptoms.

With the DRB III®, read Engine DTCs. Check and repair all engine DTCs prior to performing transmission symptom diagnostics.

With the DRB III®, read and record all Transmission DTCs.

Note: Check connectors – Clean/Repair as necessary. Poor pin to terminal connections can set DTCs.

Using the wiring diagram/schematic as a guide, inspect the wiring and connectors.

Repair as necessary.

Most DTCs set on startup but some must be set by driving the vehicle such that all diagnostic monitors have run.

Note: Check for any Technical Service Bulletins that may apply.

Perform this procedure prior to Symptom diagnosis.

Continue

Go To 2

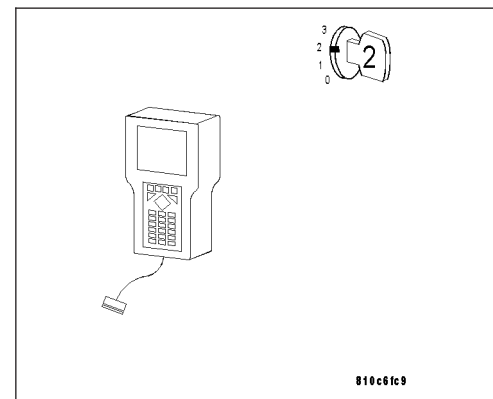

(P0715) N2 INPUT SPEED SENSOR CIRCUIT

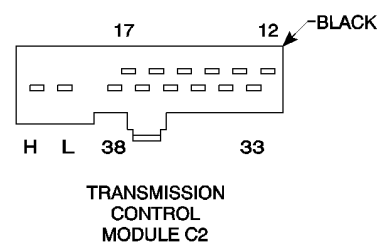
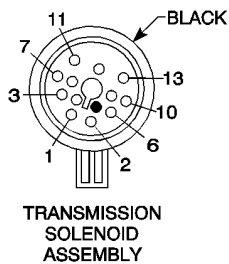
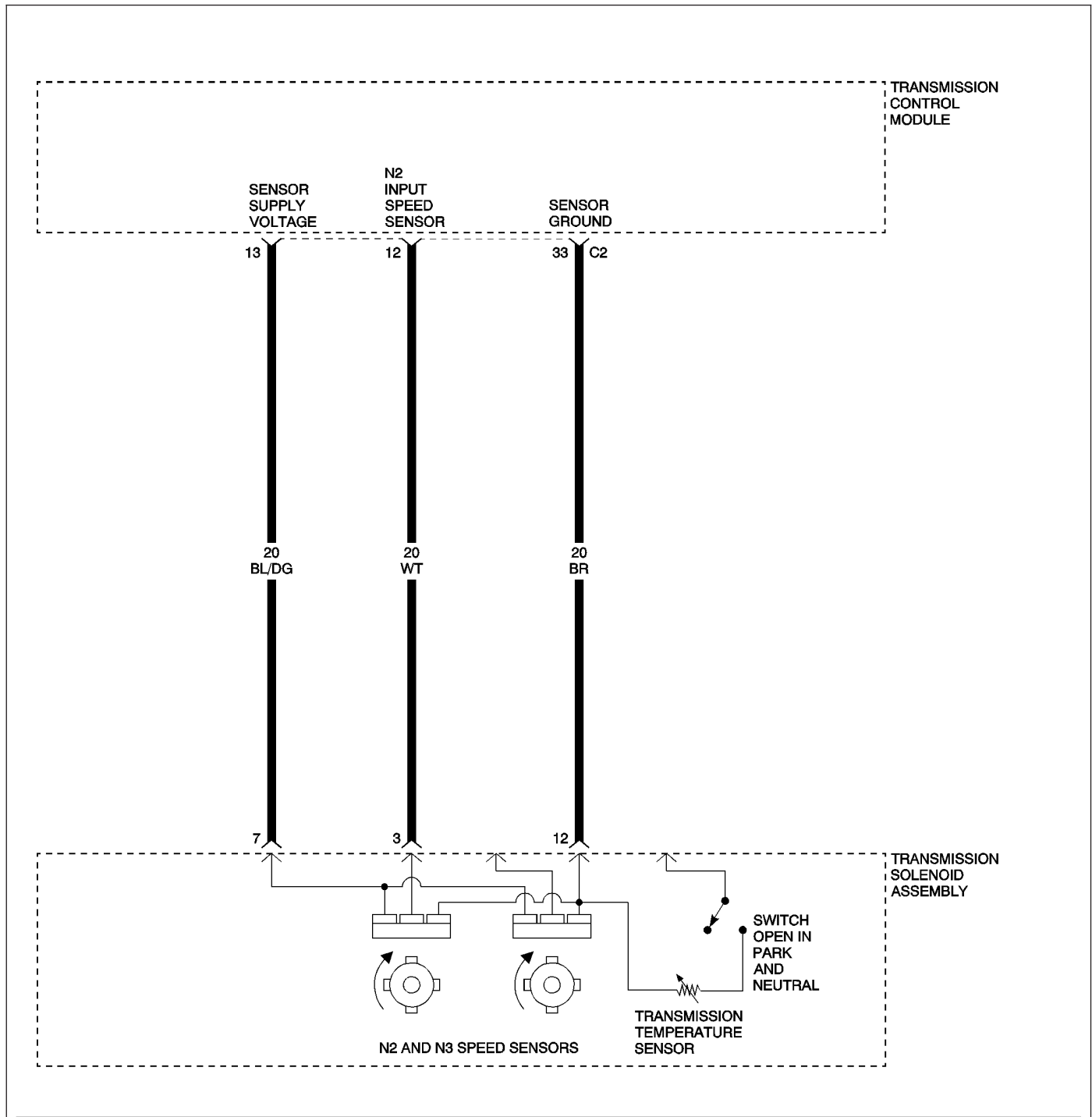

(P0753) 1-2/4-5 SOLENOID CIRCUIT (CONTINUED)**When Monitored and Set Condition**

- When Monitored: Always monitored with system active at each ignition cycle.
- Set Condition: If the TCM detects a short to battery on the solenoid control circuit, shorted solenoid, open solenoid, or an open or shorted solenoid control circuit in the TCM.

POSSIBLE CAUSES
1-2/4-5 SOLENOID CONTROL CIRCUIT OPEN
1-2/4-5 SOLENOID CONTROL CIRCUIT SHORT TO GROUND
1-2/4-5 SOLENOID CONTROL CIRCUIT SHORT TO ANOTHER CIRCUIT
1-2/4-5 SOLENOID
TRANSMISSION CONTROL MODULE

For a complete Transmission Control Module Circuit Diagram, (Refer to 21 - TRANSMISSION/TRANSAXLE/AUTOMATIC - NAG1 - SCHEMATICS AND DIAGRAMS).

Diagnostic Test**1. PRE-DIAGNOSTIC CHECK OUT**

Note: Low fluid level can be the cause of many transmission problems. If the fluid level is low, locate and repair the leak then check and adjust the fluid level in accordance with the Service Information.

Note: Always perform diagnostics with a fully charged battery to avoid false symptoms.

With the DRB III®, read Engine DTCs. Check and repair all engine DTCs prior to performing transmission symptom diagnostics.

With the DRB III®, read and record all Transmission DTCs.

Note: Check connectors - Clean/repair as necessary. Poor pin to terminal connections can set DTCs.

Using the wiring diagram/schematic as a guide, inspect the wiring and connectors. Repair as necessary.

Most DTCs set on start up but some must be set by driving the vehicle such that all diagnostic monitors have run.

Note: Check for any Technical Service Bulletins that may apply.

Perform this procedure prior to Symptom diagnosis.

Continue

Go To 2

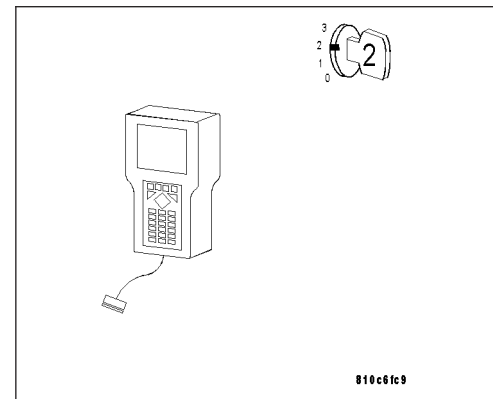

CAN BUS CIRCUIT

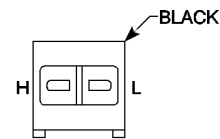
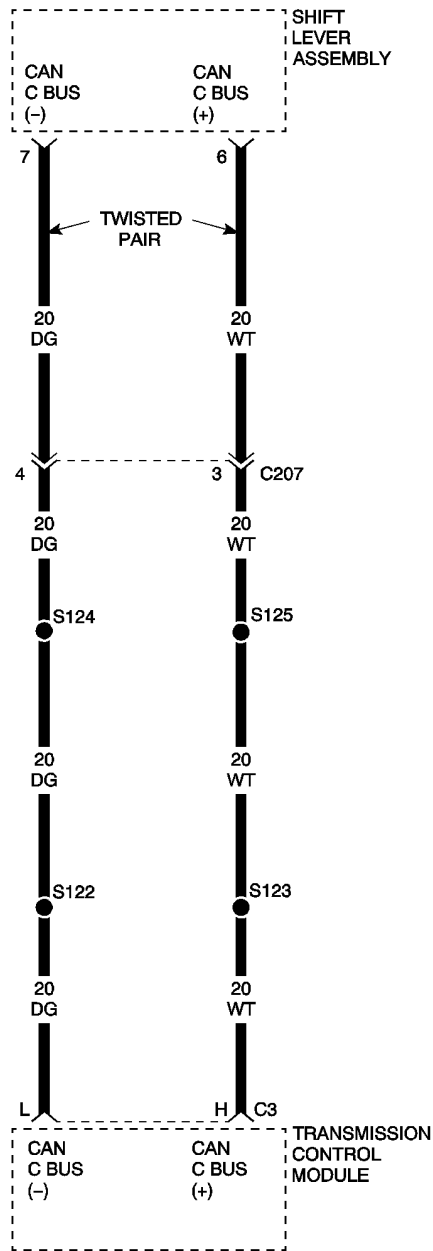

TRANSMISSION CONTROL MODULE C3

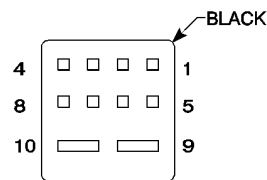

SHIFT LEVER ASSEMBLY

8. Disconnect the transmission oil cooler line banjo fittings (1) from the left and right sides of the transmission housing.

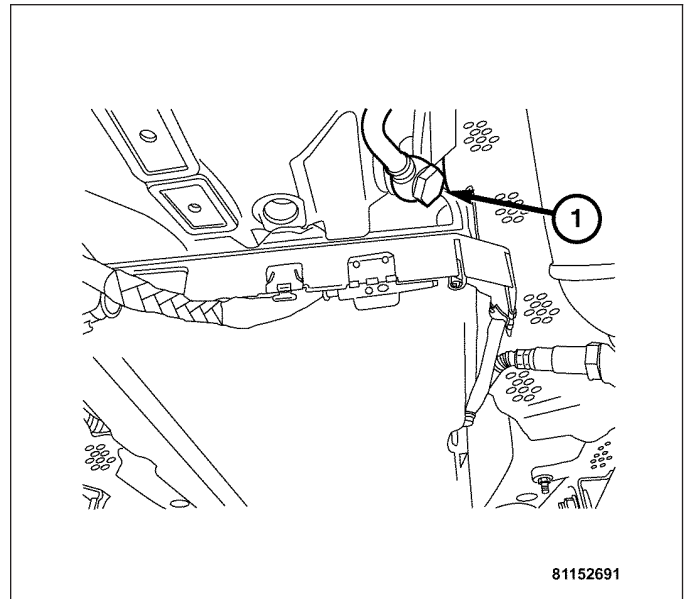

9. Remove the transmission oil cooler line retainer bolts (1) from the left and right side of the engine lower oil pan.

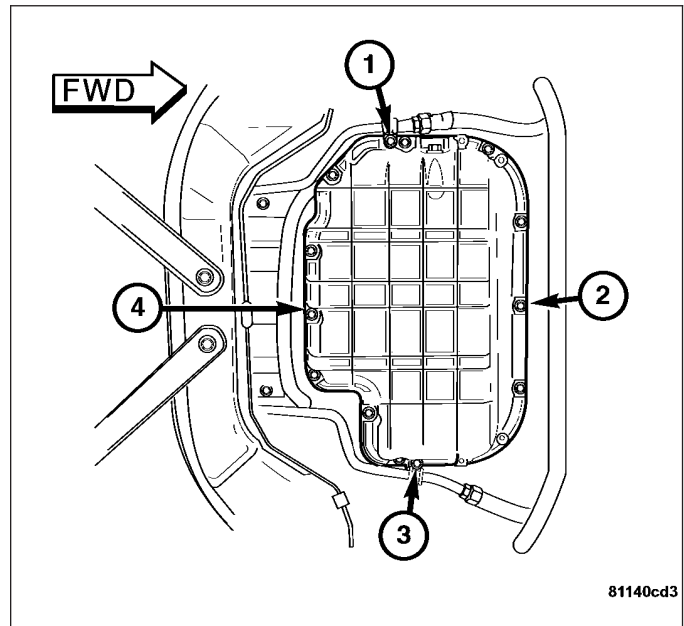

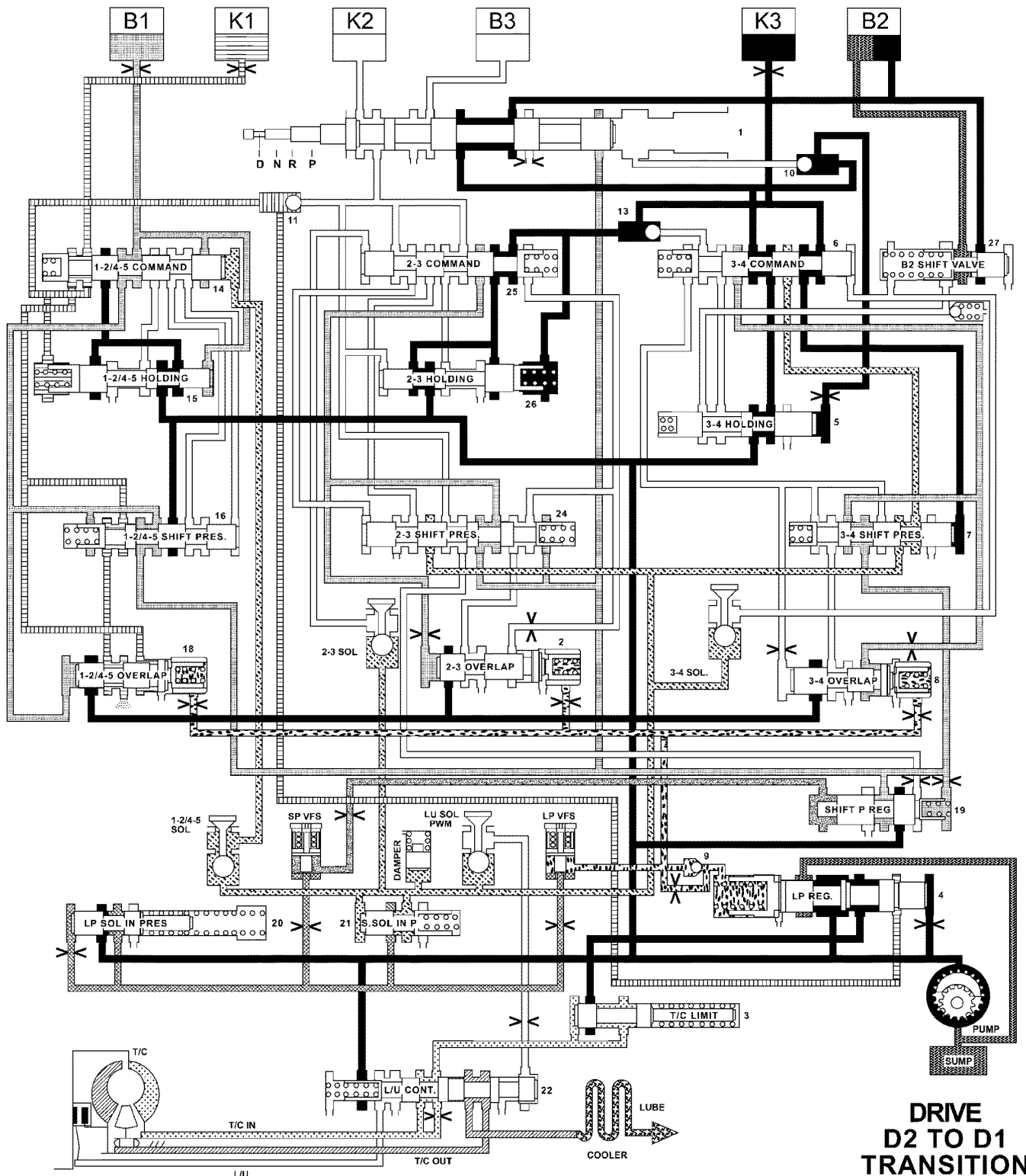

**DRIVE
D2 TO D1
TRANSITION**

LINE PRESSURE	CONTROL VALVE PRESSURE	SHIFT VALVE PRESSURE	SHIFT PRESSURE	TC IN	TC OUT	OVERLAP PRESSURE	MODULATING PRESSURE	LUBE	SHIFT PRESSURE/ CONTROL SOLENOID VALVE	SUMP

3. Install the bolts (3) and tighten to 8 N·m (71 in. lbs.).
4. Install a new oil filter..
5. Install the oil pan (5) and torque the oil pan bolts to 8 N·m (71 in. lbs.).
6. Install the oil drain plug (8) with a new drain plug gasket (9). Torque the drain plug to 20 N·m (177 in. lbs.).
7. Install the guide bushing (12) into the transmission housing and install the bolt (11) to hold the guide bushing in place.

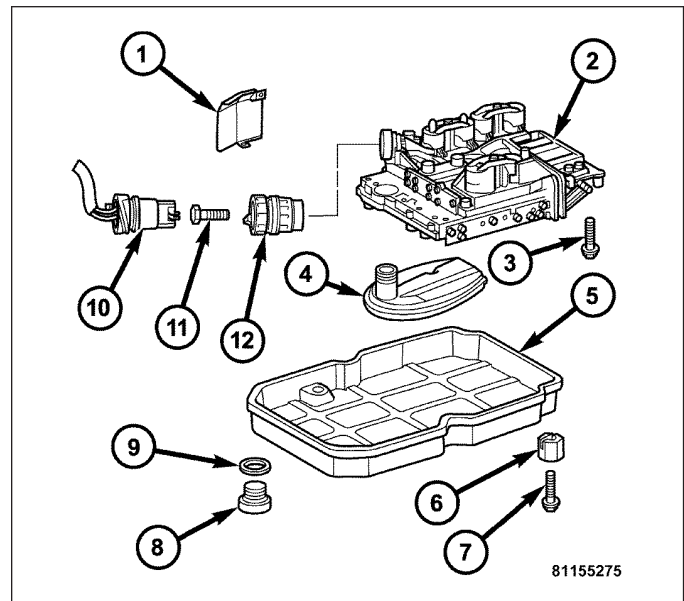

8. Check the O-ring on the plug connector (1), and replace if necessary.
9. Install the plug connector (1) into the guide bushing (2). Turn the bayonet lock of the guide bushing (2) clockwise to connect plug connector (1).

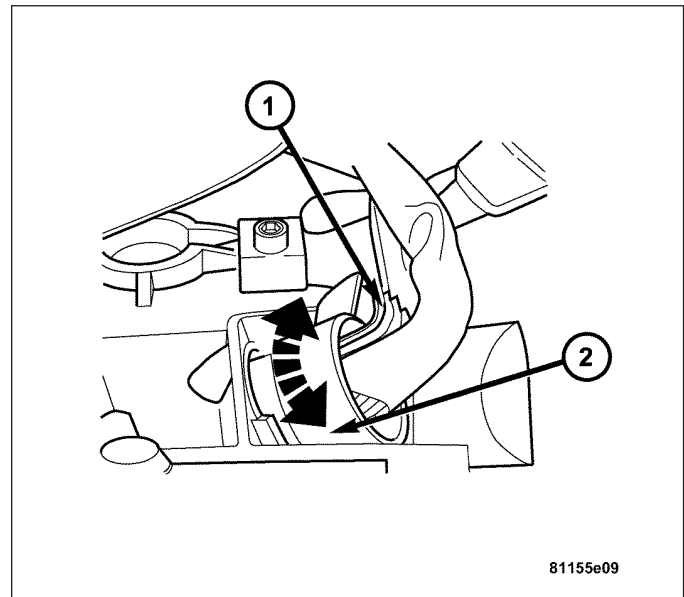

TURBINE

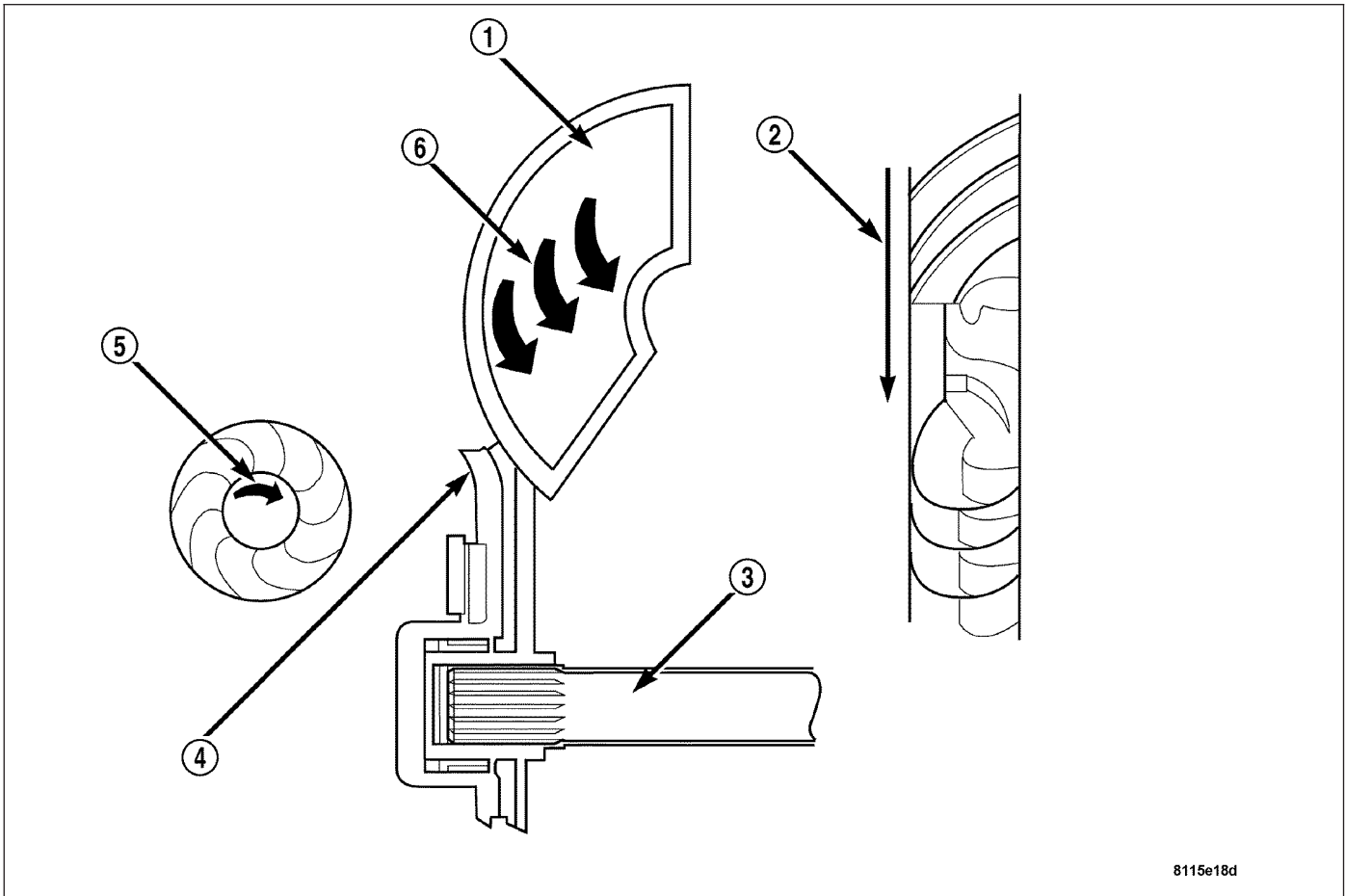

The turbine is the output, or driven, member of the converter. The turbine is mounted within the housing opposite the impeller, but is not attached to the housing. The input shaft is inserted through the center of the impeller and splined into the turbine. The design of the turbine is similar to the impeller, except the blades of the turbine are curved in the opposite direction.

STATOR

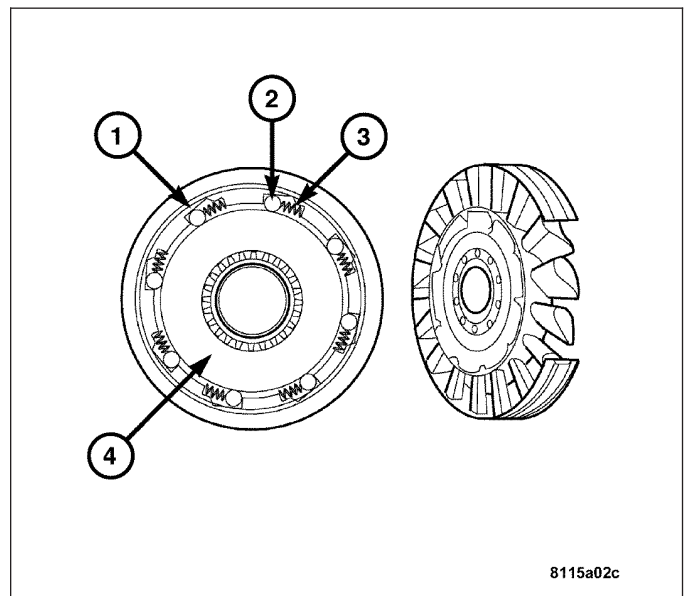

8. Remove the friction ring (1), cone ring (2), and the synchronizer ring (3).

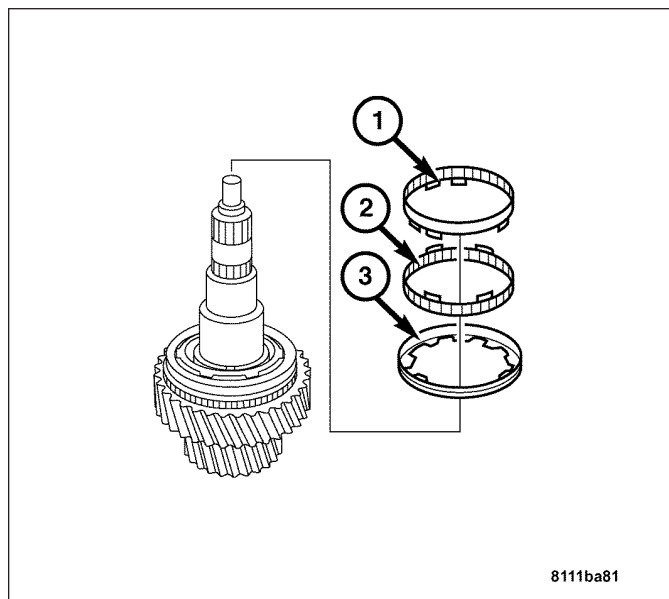

9. Remove the locking ring (1) using pliers. Remove the 1st/2nd gear synchronizer using special tool 938 and 1126.

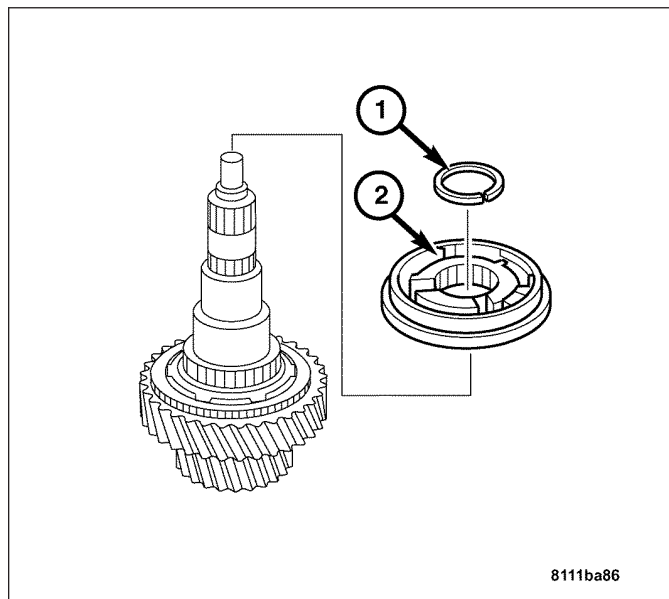

LEFT FRONT TIRE PRESSURE SENSOR/TRANSMITTER SIGNAL JAMMED

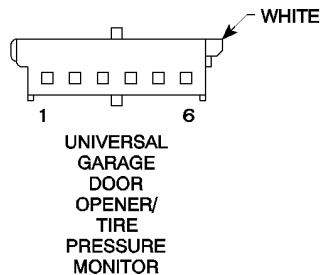
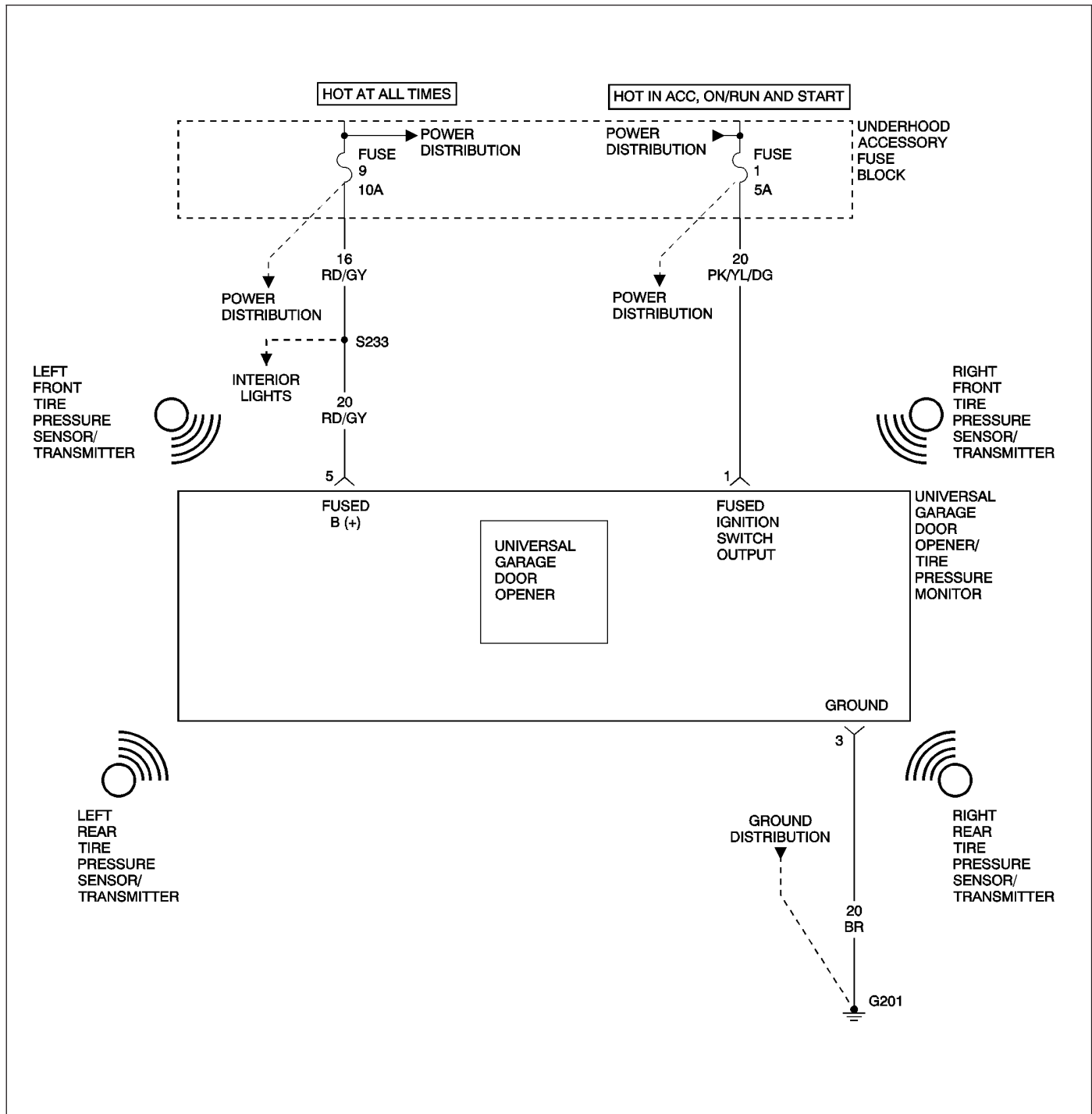

Note: The valve stem used on this vehicle is made of aluminum and the core is nickel plated brass. The original valve stem core must be reinstated and not substituted for a valve stem core made of a different material. This is required to prevent corrosion in the valve stem caused by the different metals.

1. Remove the tire/wheel from the vehicle.
2. Remove the balancing weights from the wheel (1).
3. Remove the cap from the valve stem (2).
4. Using the appropriate tool, remove the core (4) from the valve stem (2).
5. Allow the tire fully deflate.

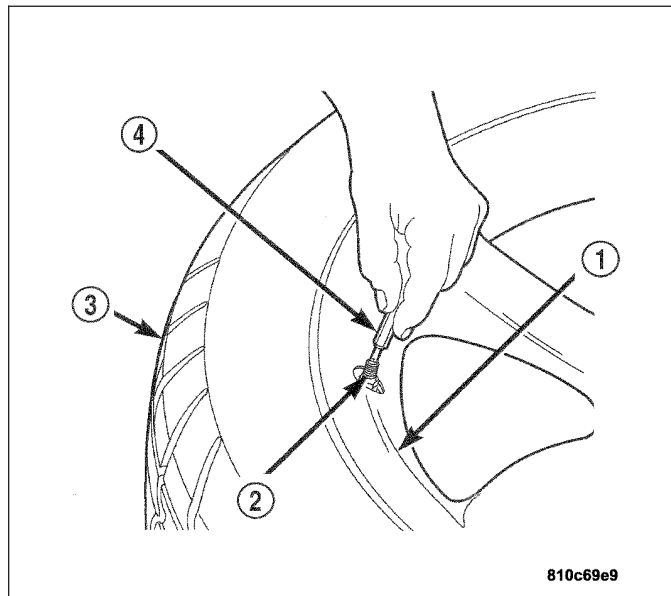

CAUTION: The pressure transmitter must be removed from the wheel and dropped into the tire prior to breaking the bead and dismounting the tire. Failure to do this will greatly increase the risk of damaging the transmitter when servicing the tire.

6. Remove the nut (1) mounting the valve stem (4) of the pressure sensor/transmitter to the wheel (2). Drop sensor/transmitter into the tire (3).

CAUTION: When breaking the top and bottom bead of the tire off the wheel, care must be used so the bead breaking mechanism on the tire changer does not damage the wheel. This includes the surface of the wheel flange on the inside of the wheel.

7. Using the tire changer manufacturer's procedure, first break down the upper bead of the tire. Then break down the bottom bead of the tire.

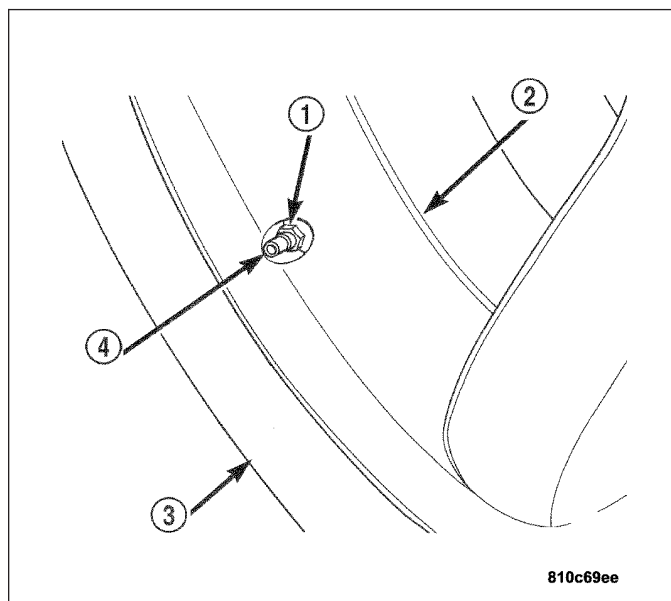

CAUTION: When dismounting the upper tire bead from the wheel, the proper procedure must be used. Not using the proper procedure will result in damage to the wheel and tire.

CONVERTIBLE TOP

TABLE OF CONTENTS

	page		page
CONVERTIBLE TOP			
DIAGNOSIS AND TESTING			
9004 POWER TOP CONTROL MODULE (PTCM) EEPROM TIMING	33	9651 TONNEAU COVER CYLINDER TRAVEL SENSOR (-) CIRCUIT SHORT TO B(+)	97
9003/9004 POWER TOP CONTROL MODULE EEPROM ERROR	35	9652 TONNEAU COVER CYLINDER TRAVEL SENSOR (+) CIRCUIT SHORT TO B(+)	99
9009/9010 POWER TOP CONTROL MODULE (PTCM) LOW VOLTAGE	37	9701/9702 THERMO PROTECTION ACTIVE	101
9011 POWER TOP CONTROL MODULE (PTCM) OVER VOLTAGE	39	9710 RIGHT ROTATION RELAY CONTROL CIRCUIT SHORT TO GROUND	103
9012 STOP MODE LONGER THAN 10 MINUTES	41	9711 RIGHT ROTATION RELAY CONTROL CIRCUIT OPEN/SHORT TO B(+)	104
9076 NO COMMUNICATION WITH BODY CONTROL MODULE (BCM)	43	9710 LEFT ROTATION RELAY CONTROL CIRCUIT SHORT TO GROUND	108
9078 NO COMMUNICATION WITH CENTRAL LOCKING PUMP/SECURITY SYSTEM MODULE (CPL/SSM)	45	9721 LEFT ROTATION RELAY CONTROL CIRCUIT OPEN/SHORT TO B(+)	110
9610 MAIN CYLINDER TRAVEL SENSOR (ROD SIDE) +/- CIRCUITS OPEN/SHORT TO GROUND	48	9810 HYDRAULIC SOLENOID S1 SUPPLY VOLTAGE CIRCUIT SHORT TO GROUND	114
9611 MAIN CYLINDER TRAVEL SENSOR (ROD SIDE) (-) CIRCUIT SHORT TO B(+)	54	9811 HYDRAULIC SOLENOID S1 SUPPLY VOLTAGE CIRCUIT OPEN/SHORT TO B(+)	116
9612 MAIN CYLINDER TRAVEL SENSOR (ROD SIDE) (+) CIRCUIT TO B(+)	57	9820 HYDRAULIC SOLENOID S2 SUPPLY VOLTAGE CIRCUIT SHORT TO GROUND	120
9620 MAIN CYLINDER TRAVEL SENSOR (BASE SIDE) +/- CIRCUIT OPEN/SHORT TO GROUND	60	9821 HYDRAULIC SOLENOID S2 SUPPLY VOLTAGE CIRCUIT OPEN/SHORT TO B(+)	122
9621 MAIN CYLINDER TRAVEL SENSOR (BASE SIDE) (-) CIRCUIT SHORT TO B(+)	66	9830 HYDRAULIC SOLENOID S3 SUPPLY VOLTAGE CIRCUIT SHORT TO GROUND	126
9622 MAIN CYLINDER TRAVEL SENSOR (BASE SIDE) (+) SHORT CIRCUIT TO B(+)	69	9831 HYDRAULIC SOLENOID S3 SUPPLY VOLTAGE CIRCUIT OPEN/SHORT TO B(+)	128
9630 REAR BOW TRAVEL SENSOR (ROD SIDE) +/- CIRCUIT OPEN/SHORT TO GROUND	72	9840 HYDRAULIC SOLENOID S4 SUPPLY VOLTAGE CIRCUIT SHORT TO GROUND	132
9631 REAR BOW TRAVEL SENSOR (ROD SIDE) (-) CIRCUIT SHORT TO B(+)	77	9841 HYDRAULIC SOLENOID S4 SUPPLY VOLTAGE CIRCUIT OPEN/SHORT TO B(+)	134
9632 REAR BOW CYLINDER TRAVEL SENSOR (ROD SIDE) (+) SHORT CIRCUIT TO B(+)	80	9860 TRUNK LATCH ACTUATOR UNLOCK CONTROL CIRCUIT SHORT TO GROUND	139
9640 REAR BOW TRAVEL SENSOR (BASE SIDE) +/- CIRCUIT OPEN/SHORT TO GROUND	83	9861 TRUNK LATCH ACTUATOR UNLOCK CONTROL CIRCUIT SHORT TO B(+)	142
9641 REAR BOW CYLINDER TRAVEL SENSOR (BASE SIDE) (-) CIRCUIT SHORT TO B(+)	88	9870 TRUNK LATCH ACTUATOR LOCK CONTROL CIRCUIT SHORT TO GROUND	146
9642 REAR BOW CYLINDER TRAVEL SENSOR (BASE SIDE) (+) SHORT CIRCUIT TO B(+)	91	9871 TRUNK LATCH ACTUATOR LOCK CONTROL CIRCUIT SHORT TO B(+)	149
9650 TONNEAU COVER CYLINDER TRAVEL SENSOR +/- CIRCUIT OPEN/SHORT TO GROUND	94	9901 MAIN CYLINDER TRAVEL SENSOR (ROD SIDE) INOPERATIVE	153
		9902 MAIN CYLINDER TRAVEL SENSOR (ROD SIDE) STUCK	155
		9903 MAIN CYLINDER TRAVEL SENSOR (BASE SIDE) INOPERATIVE	157
		9904 MAIN CYLINDER TRAVEL SENSOR (BASE SIDE) STUCK	159
		9905 REAR BOW CYLINDER TRAVEL SENSOR (ROD SIDE) INOPERATIVE	161
		9906 REAR BOW CYLINDER TRAVEL SENSOR (ROD SIDE) STUCK	163
		9907 REAR BOW CYLINDER TRAVEL SENSOR (BASE SIDE) INOPERATIVE	165

9630 REAR BOW TRAVEL SENSOR (ROD SIDE) +/- CIRCUIT OPEN/SHORT TO GROUND

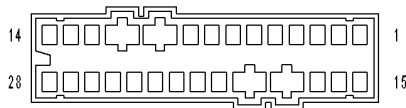
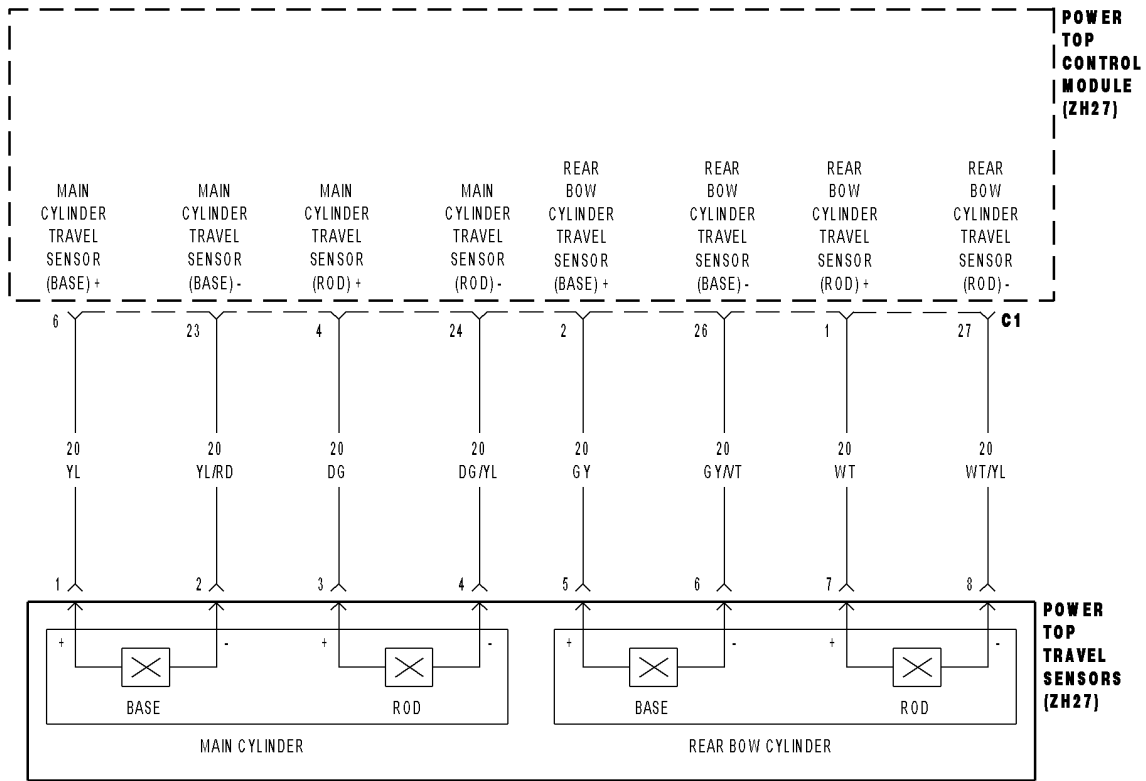

POWER TOP CONTROL MODULE C1 (ZH27)

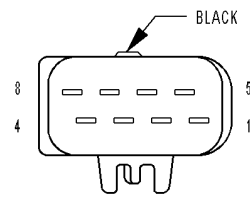

POWER TOP TRAVEL SENSORS (ZH27)

9721 LEFT ROTATION RELAY CONTROL CIRCUIT OPEN/SHORT TO B(+) (CONTINUED)

5. Open Rotation Relay Ground circuit

With the ignition off.

Measure the resistance of the Rotation Relay Ground circuit from the Left Rotation Relay harness connector to the PTCM C2 harness connector.

Is the resistance below 5.0 ohms?

- Yes** >> Replace the Left Rotation Relay.
Perform POWER TOP CONTROL MODULE VERIFICATION TEST.
- No** >> Repair the Rotation Relay Ground circuit for an open.
Perform POWER TOP CONTROL MODULE VERIFICATION TEST.

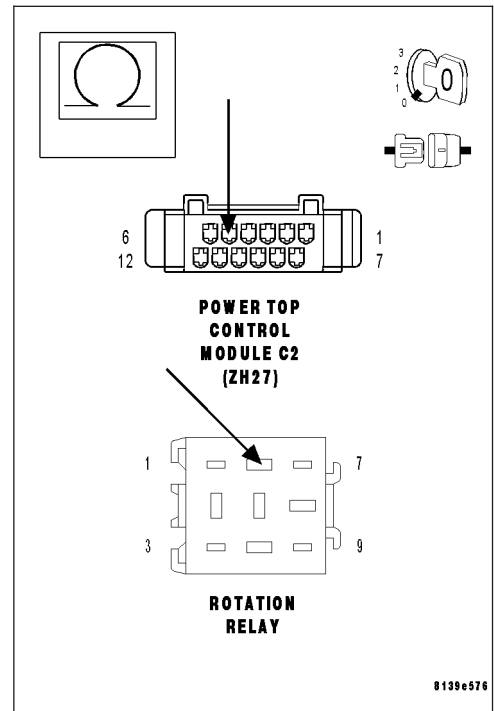

6. Rotation Relay Ground Circuit

Turn the ignition off.

Disconnect the Power Top Control Module C2 harness connector. Measure the resistance between the Rotation Relay Ground circuit and the Left Rotation Relay Control circuit at the Power Top Control Module C2 harness connector.

Is the resistance between 60.0 - 90.0 ohms?

- Yes** >> Replace the Power Top Control Module.(Refer to 8 - ELECTRICAL/ELECTRONIC CONTROL MODULES/ POWER TOP CONTROL MODULE - REMOVAL).
Perform POWER TOP CONTROL MODULE VERIFICATION TEST.
- No** >> Repair the Rotation Relay Ground circuit for an open.
Perform POWER TOP CONTROL MODULE VERIFICATION TEST.

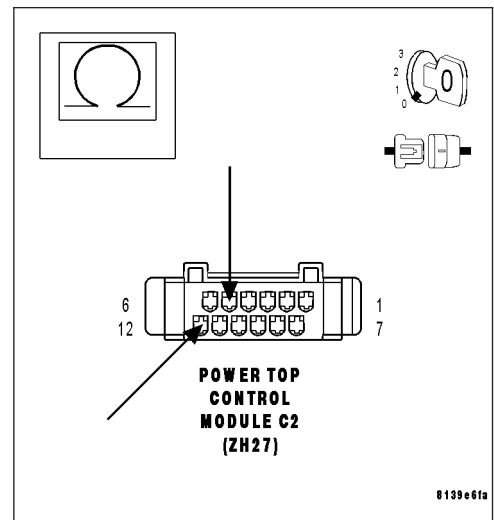

9901 MAIN CYLINDER TRAVEL SENSOR (ROD SIDE) INOPERATIVE (CONTINUED)

- **When Monitored:** Continuous with the ignition on.
- **Set Condition:** When the Power Top Control Module senses the Main Travel Sensor (Rod Side) inactive with the Power Top in the closed position.

Possible Causes
POWER TOP CONTROL MODULE

Always perform the Pre-Diagnostic Troubleshooting procedure before proceeding.

Diagnostic Test**1. Check for Current DTCs**

Turn the ignition on.

With the DRBIII®, read and record the Power Top Control Module (PTCM) DTCs.

Note: If any other Main Cylinder Travel Sensor DTCs have been set, diagnose the other Power Top Control Module (PTCM) DTCs first before continuing.

With the DRB III®, erase the Power Top Control Module (PTCM) DTCs.

Press the Power Top Switch to raise and lower the Power Top.

With the DRBIII®, read the Power Top Control Module (PTCM) DTCs.

Did this DTC set again?

Yes >> Replace the Power Top Control Module.(Refer to 8 - ELECTRICAL/ELECTRONIC CONTROL MODULES/POWER TOP CONTROL MODULE - REMOVAL).
Perform POWER TOP CONTROL MODULE VERIFICATION TEST.

No >> Go To 2

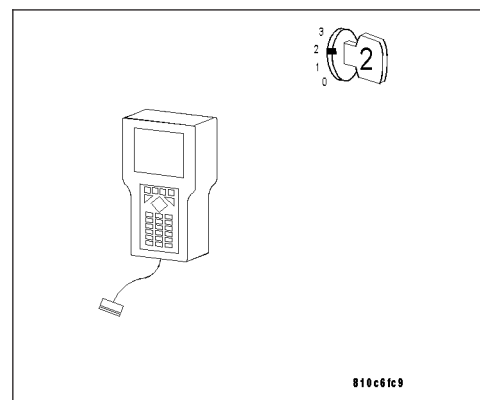
**2. INTERMITTENT WIRING AND CONNECTORS**

The condition that caused this DTC to set is currently not present. Inspect the related wiring harness for a possible intermittent condition.

Note: Check connectors — Clean/repair as necessary. Poor pin to terminal connections can set DTCs.

Note: Check for any Technical Service Bulletins that may apply.

Using the wiring diagram/schematic as a guide, inspect the wiring and connectors specific to this DTC. Wiggle the wires while checking for shorts and open circuits.

Were there any problems found?

Yes >> Repair as necessary.
Perform POWER TOP CONTROL MODULE VERIFICATION TEST.

No >> The condition that caused this DTC to set is currently not present. Inspect the related wiring harness for a possible intermittent condition.

9930 UNKNOWN TOP POSITION

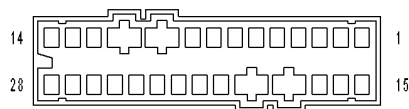
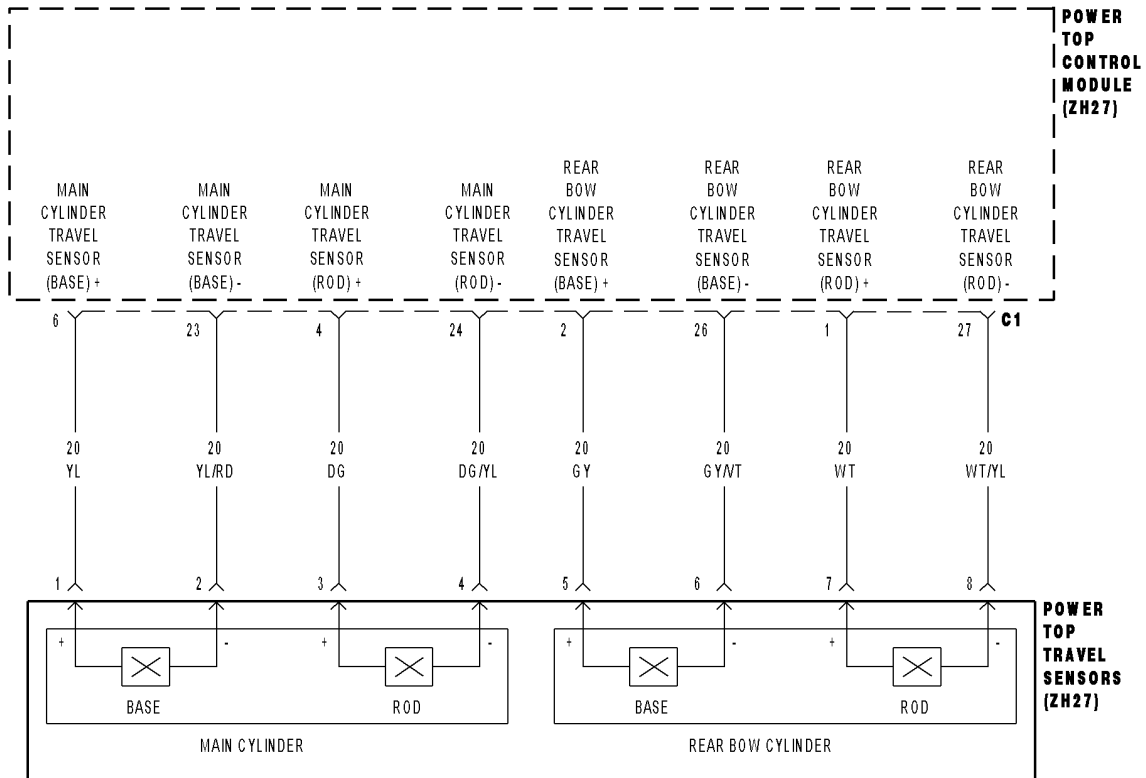

POWER TOP CONTROL MODULE C1 (ZH27)

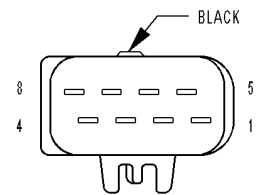

POWER TOP TRAVEL SENSORS (ZH27)

REMOVAL - ROADSTER

1. Remove the decklid trim fasteners (2).
2. Disconnect the emergency release cable (3) and remove from the trim panel (1).

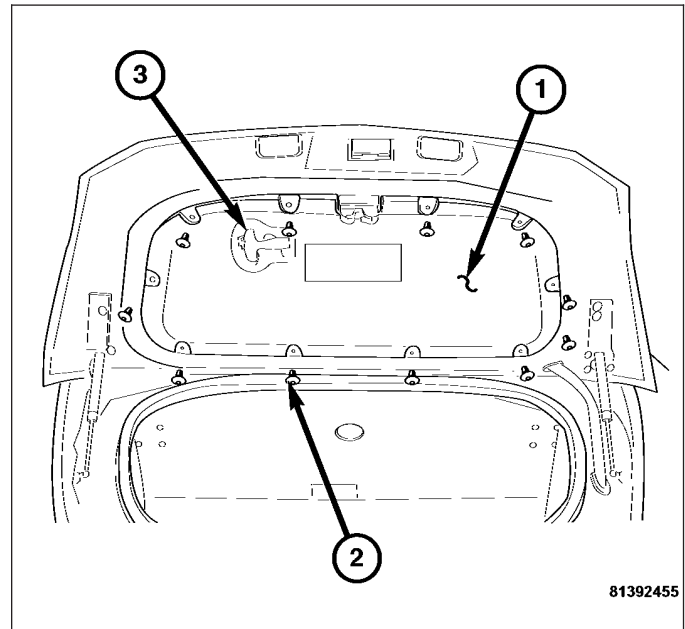

INSTALLATION

INSTALLATION - COUPE

UPPER LIFTGATE TRIM PANEL

1. Push up on the upper liftgate trim panel (2) to attach it to the liftgate.
2. Install the two screws (1) attaching the upper liftgate trim panel (2) to the liftgate.
3. Install the lower trim panel. Refer to Lower Liftgate Trim Panel.

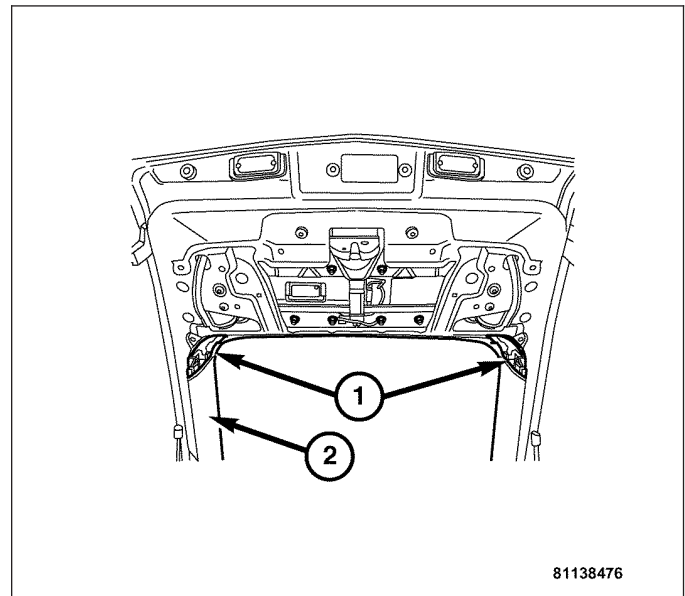

STRUCTURAL ADHESIVE LOCATIONS

SPECIFICATIONS - STRUCTURAL ADHESIVES

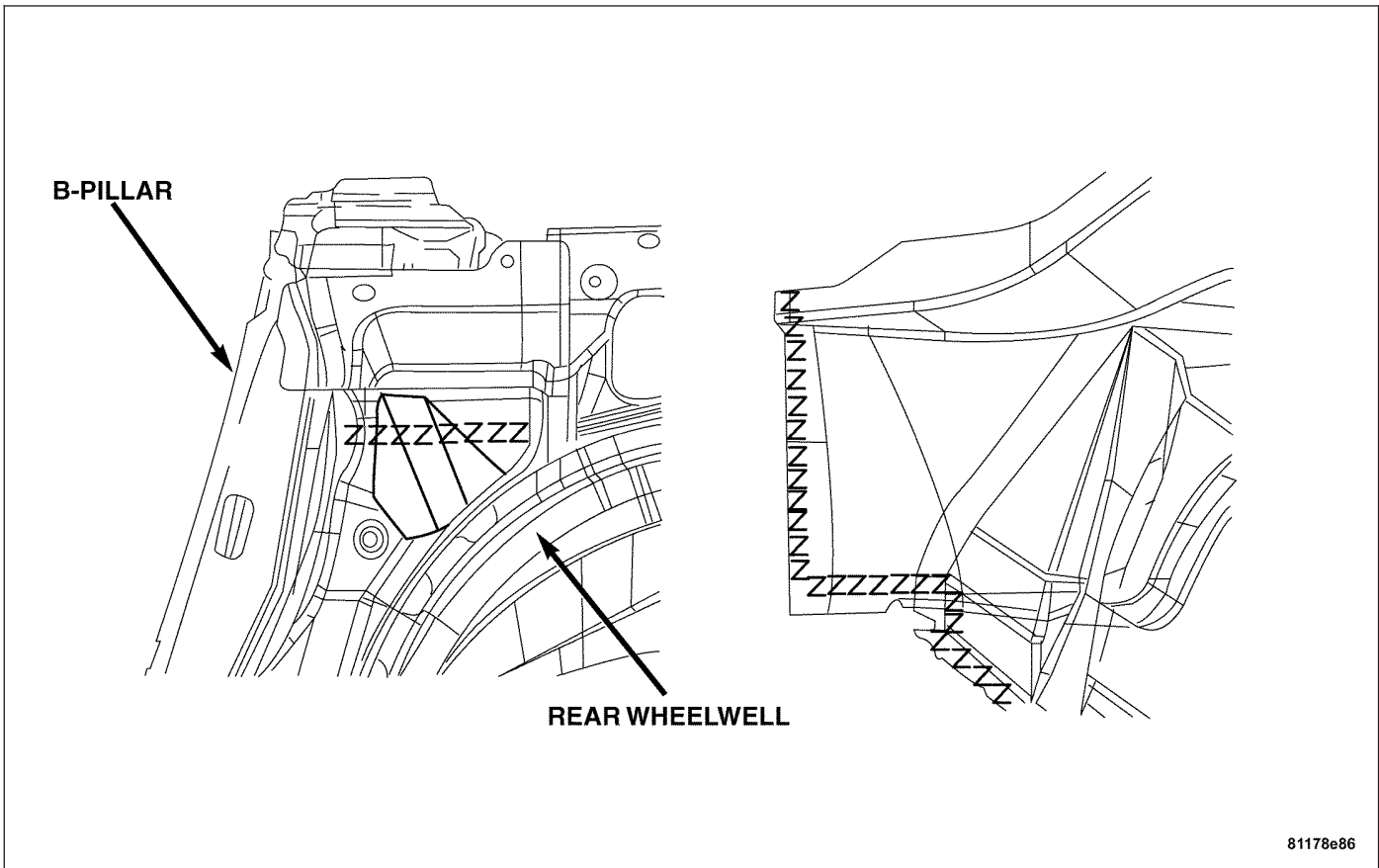

8. Install the spoiler wing (2) to the linkage (1). (Refer to 23 - BODY/EXTERIOR/SPOILER - INSTALLATION).

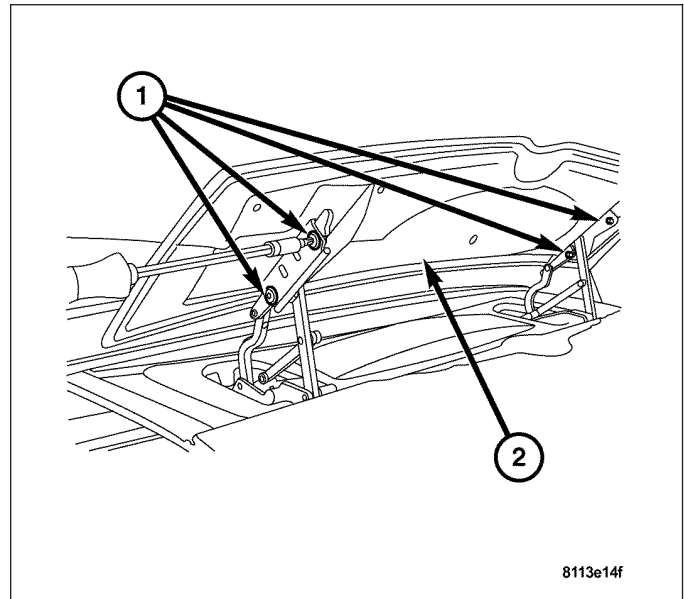

9. Verify the rear spoiler operation by using the manual override switch to operate the spoiler making sure there is smooth operation and proper alignment.

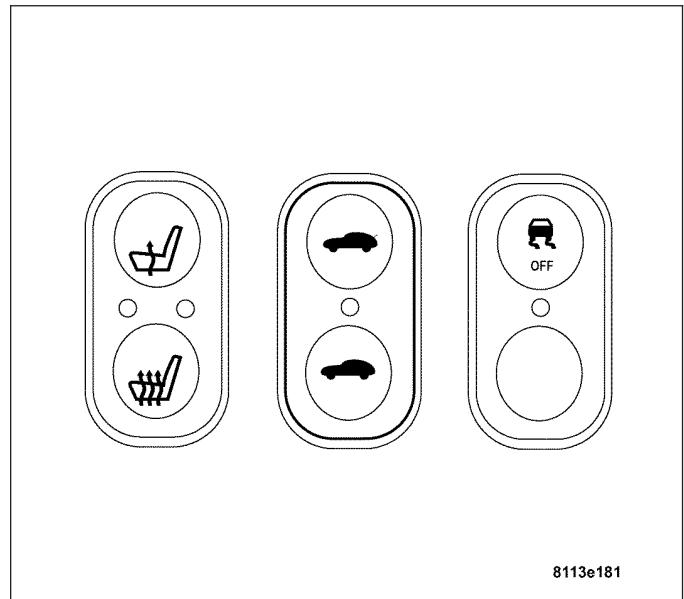

REMOVAL - LOWER INSTRUMENT PANEL (RIGHT)

1. Fold back the carpet (3).
2. Remove the screws (2) attaching the lower instrument panel to the glove compartment.
3. Pull the lower instrument panel (1) out.

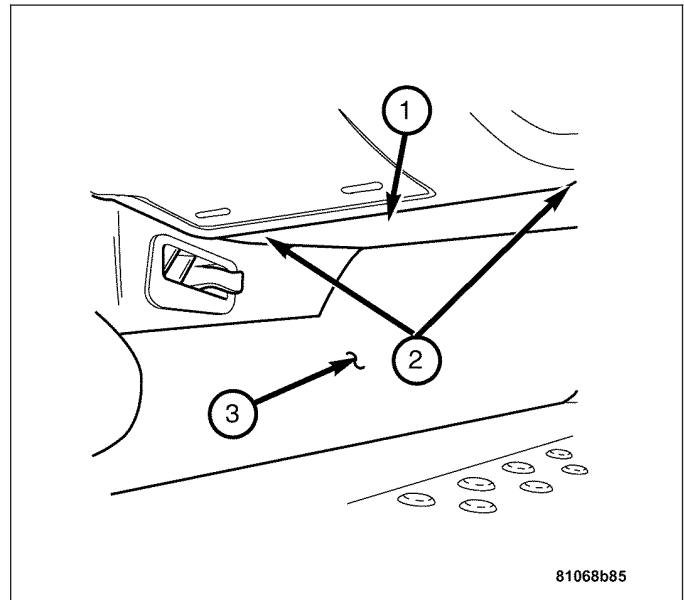
**REMOVAL - LOWER I/P PANEL RIGHT - RHD**

1. Remove the right side I/P air outlet deflector (1) by pulling it out of the I/P.
2. Remove the screw (5) attaching the steering column panel under the steering column, then remove the steering column panel.
3. Remove the fuse panel side cover.
4. Remove the two screws (4) attaching the lower I/P to the illumination control module and the screw (3) on the side of the I/P to the illumination control module support bar.
5. Disconnect the illumination control module harness connector, then remove the illumination control module from the I/P.
6. Remove the screw (2) attaching the lower I/P panel to the cluster cover.

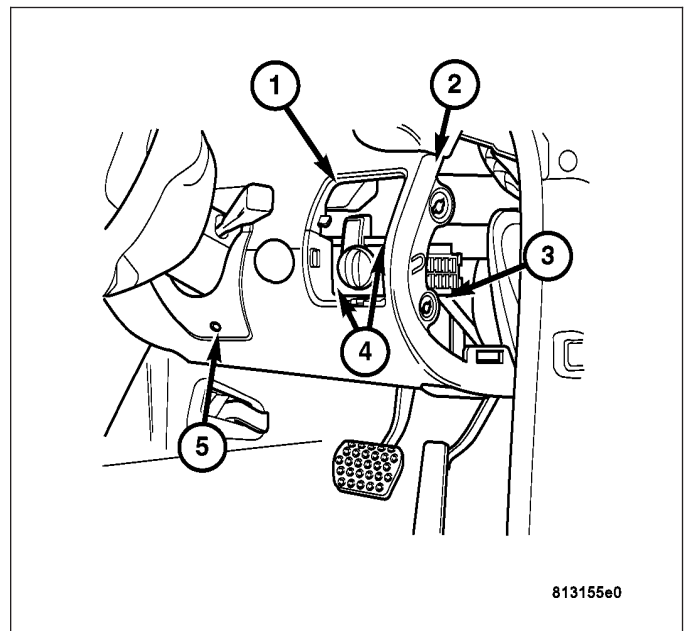

REMOVAL - SHIFT LEVER ASSEMBLY COVER

1. Remove the chrome plastic frame (1) with a plastic wedge.

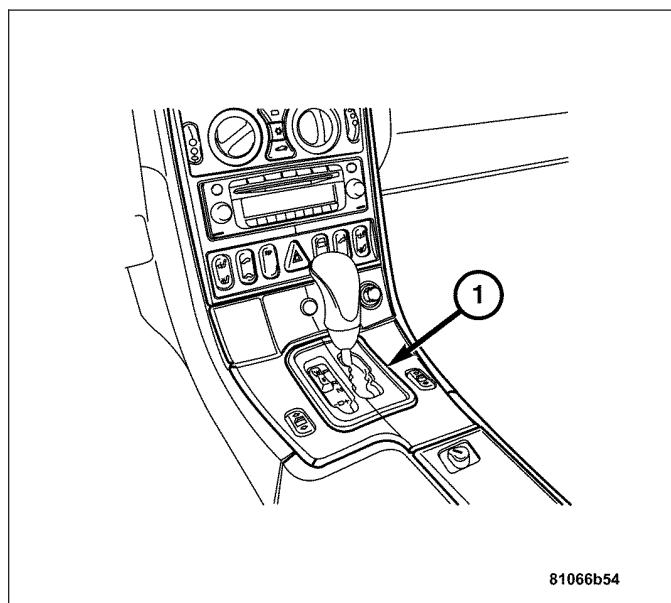

2. Press the cover (1) out of the catch in the center console at the rear and side with a plastic wedge.

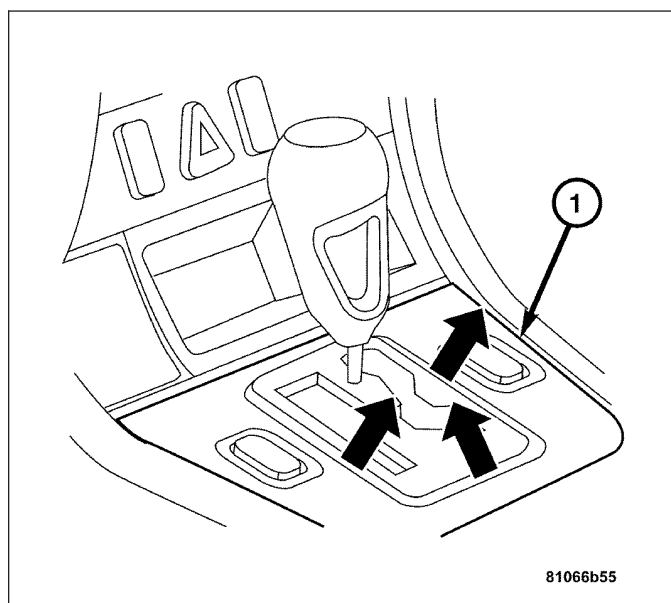

SEAT CUSHION COVER

REMOVAL

1. Remove the front seat cushion. (Refer to 23 - BODY/SEATS/SEAT CUSHION - REMOVAL).
2. Lay the seat cushion on a suitable surface with the cover facing down.
3. Unhook the two fabric tabs on the cushion shell (1).

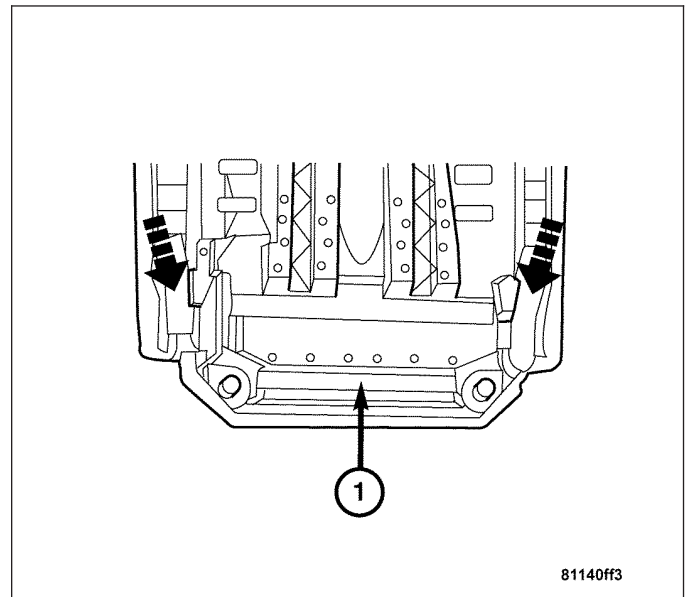

4. Unhook the cover (2) all the way around the clip groove in the seat cushion shell (1).

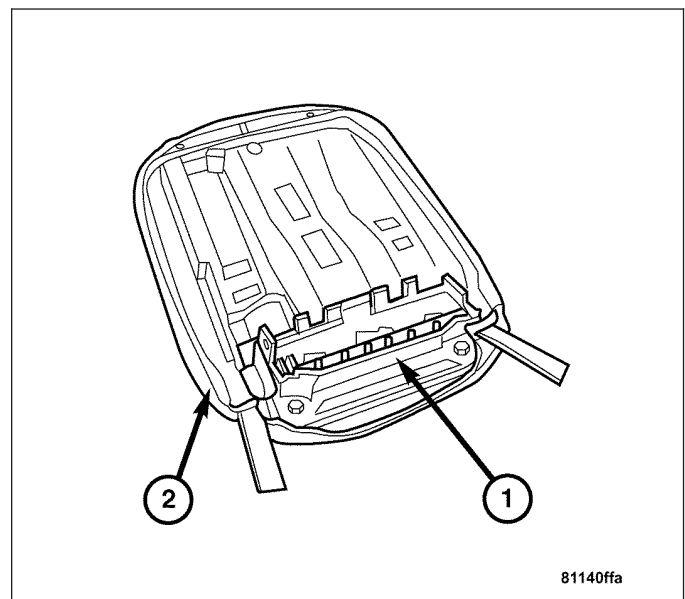

When the PTCM senses that the rear bow has been lowered and locked by the rear bow travel sensor and the rear bow switch, all hydraulic pressure is released.

STANDARD PROCEDURE

STANDARD PROCEDURE - RELIEVING HYDRAULIC PRESSURE

Note: The hydraulic pressure must be relieved before the top can manually be raised or lowered.

1. Turn the ignition to the "ON" position.
2. Push down on the convertible top switch and hold in that position.
3. Turn the ignition "OFF" and continue to push down on the switch 5 seconds.
4. After 5 seconds the hydraulic system pressure will be relieved.

STANDARD PROCEDURE - MANUALLY LOWER TOP

Note: The pressure from the top hydraulic system must be relieved before attempting to manually lower top (Refer to 23 - BODY/CONVERTIBLE TOP - STANDARD PROCEDURE).

Note: Make sure the rear cargo compartment divider is secured in its vertical position.

1. Lower the windows and open the doors.
2. Unlock the top from the windshield header by pushing the release handle button, pulling the handle down and turning it clockwise just past a quarter turn.

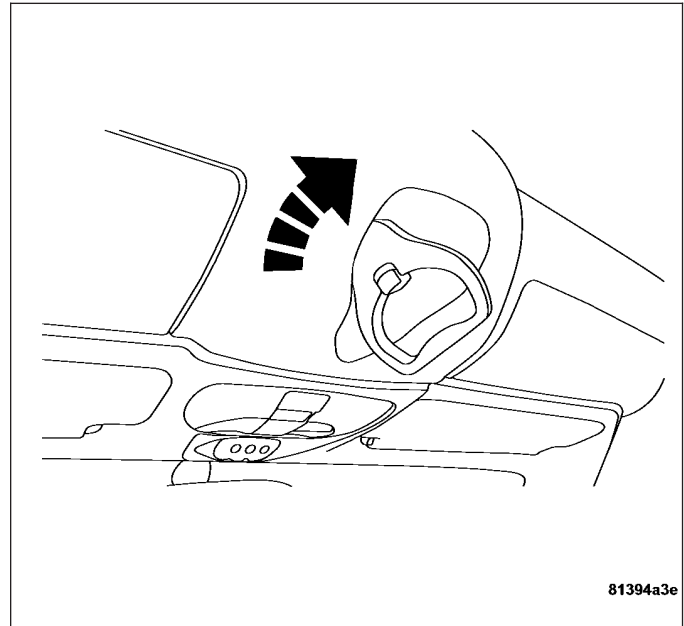

15. Fold the right side of the cover (4) up to gain access to the roof open switch (1).
16. Disconnect the roof open switch harness connector (3).
17. Remove the roof open switch retaining screw from the inside and remove the switch from the top frame (2).

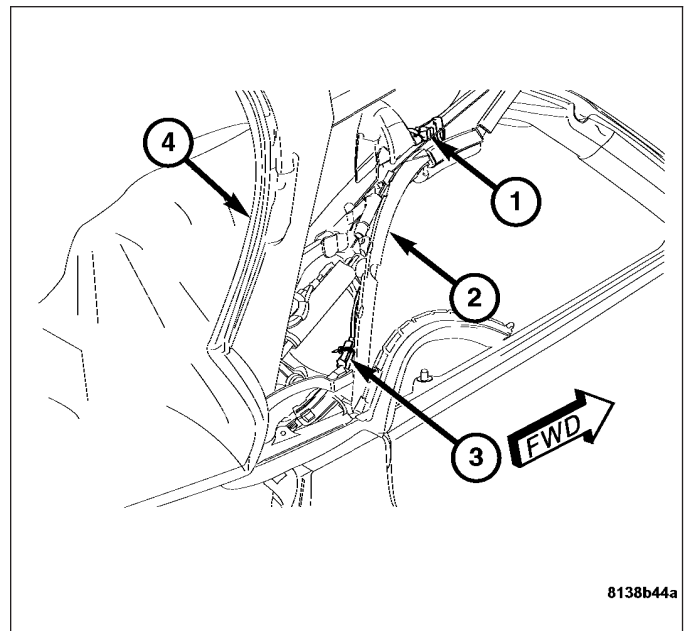

INSTALLATION

INSTALLATION - POWER TOP SWITCH

1. Install the power top switch (1) into the center console.
2. Connect the power top switch harness connector.
3. Install the center console (2). (Refer to 23 - BODY/ INTERIOR/CENTER CONSOLE - INSTALLATION).

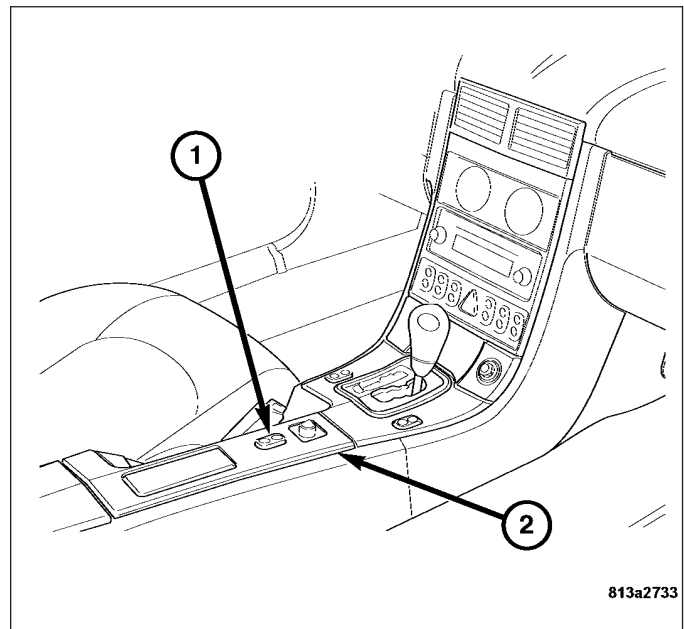

2. Firmly press the convertible top side rail weatherstrip (1) onto the bow.
3. Lower the convertible top.

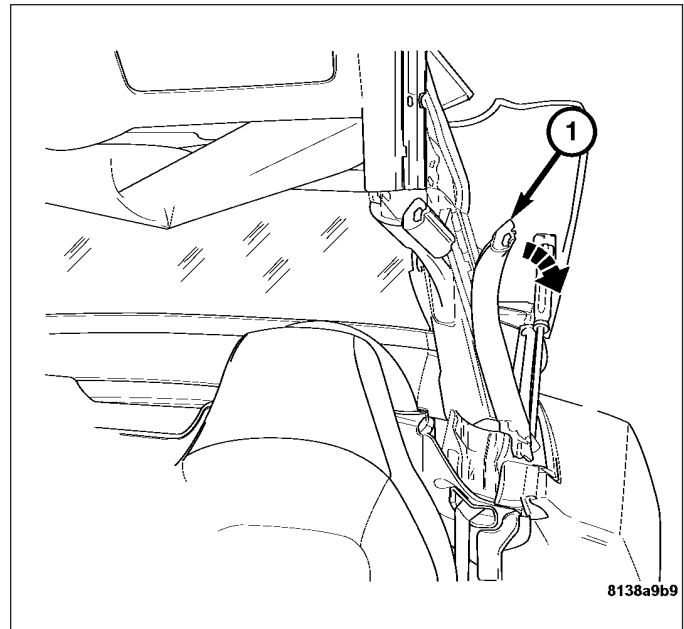

TRUNK OPENING WEATHERSTRIP REMOVAL

1. Using a trim stick or other suitable device, carefully pry up the inner edge.
2. Grasp the edge of the weatherstrip (1) and pull outward to remove the seal from the trunk.

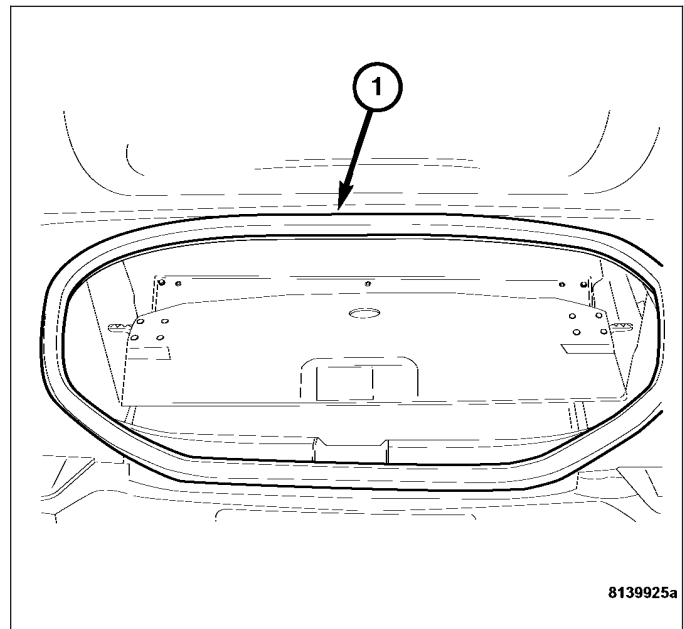

A/C PRESSURE SENSOR CIRCUIT (CONTINUED)

7. READ A/C PRESSURE SENSOR VOLTAGE WITH DRB III®

With the ignition on.

With the DRB III®, read the A/C Pressure Sensor voltage.

Is the voltage below 0.5 of a volt?

Yes >> Go to 8

No >> The condition that caused this DTC to set is currently not present. Inspect the related wiring harness for a possible intermittent condition.
Perform BODY VERIFICATION TEST.

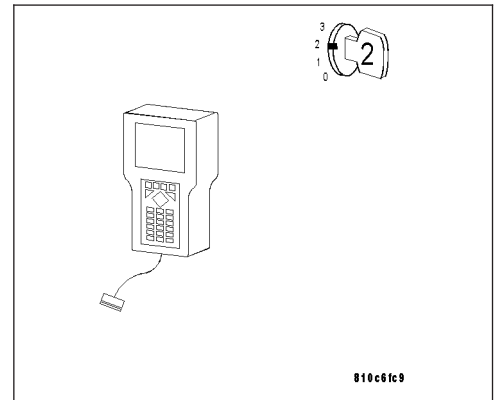

8. MEASURE THE VOLTAGE OF THE 5-VOLT SUPPLY CIRCUIT

Turn the ignition off.

Disconnect the A/C Pressure Sensor harness connector.

Note: Check connector - Clean/repair as necessary.

Turn the ignition on.

Measure the voltage of the 5-Volt Supply circuit at the A/C Pressure Sensor harness connector.

Is the voltage between 4.5 and 5.0 volts?

Yes >> Go to 9

No >> Go to 12

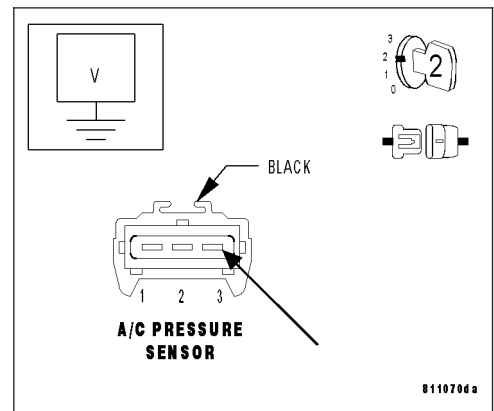

9. MONITOR A/C PRESSURE SENSOR VOLTAGE WITH DRB III®

With the ignition on.

With the DRB III®, monitor the A/C Pressure Sensor voltage.

Is the voltage above 0.5 of a volt?

Yes >> Replace the A/C Pressure Sensor. (Refer to 24 - HEATING & AIR CONDITIONING/CONTROLS/A/C PRESSURE TRANSDUCER - REMOVAL)
Perform BODY VERIFICATION TEST.

No >> Go to 10

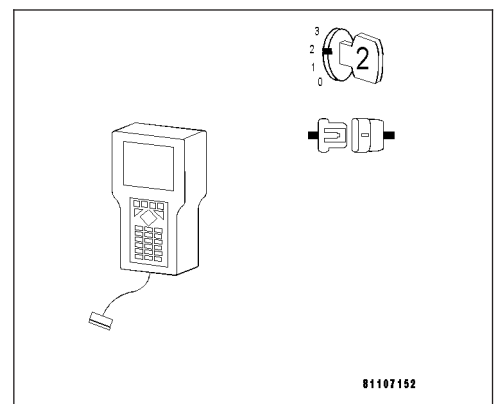

4. The compressor clutch coil is acceptable if the current draw measured at the clutch coil is 2.0 to 3.9 amperes with the electrical system voltage at 11.5 to 12.5 volts. This should only be checked with the work area temperature at 21° C (70° F). If system voltage is more than 12.5 volts, add electrical loads by turning on electrical accessories until the system voltage drops below 12.5 volts.
 - a. If the clutch coil current reading is four amperes or more, the coil is shorted and should be replaced.
 - b. If the clutch coil current reading is zero, the coil is open and should be replaced.

STANDARD PROCEDURE - COMPRESSOR CLUTCH BREAK-IN

After a new compressor clutch has been installed, cycle the compressor clutch approximately twenty times (five seconds on, then five seconds off). During this procedure, set the A/C Heater control in the Recirculation Mode, the A/C button in the on position, the blower motor switch in the highest speed position, and the engine speed at 1500 to 2000 rpm. This procedure (burnishing) will seat the opposing friction surfaces and provide a higher compressor clutch torque capability.

BLOWER MOTOR REGULATOR

REMOVAL

1. Remove the lower instrument panel cover (2) from the instrument panel (1). (Refer to 23 - BODY/INSTRUMENT PANEL/INSTRUMENT PANEL ASSEMBLY - REMOVAL).

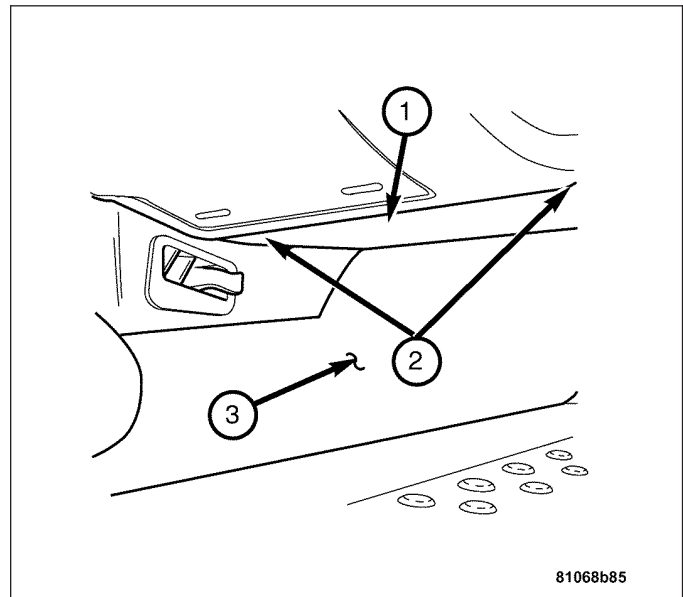

2. Disconnect the blower motor electrical connector (1) from the relief in the blower motor door.

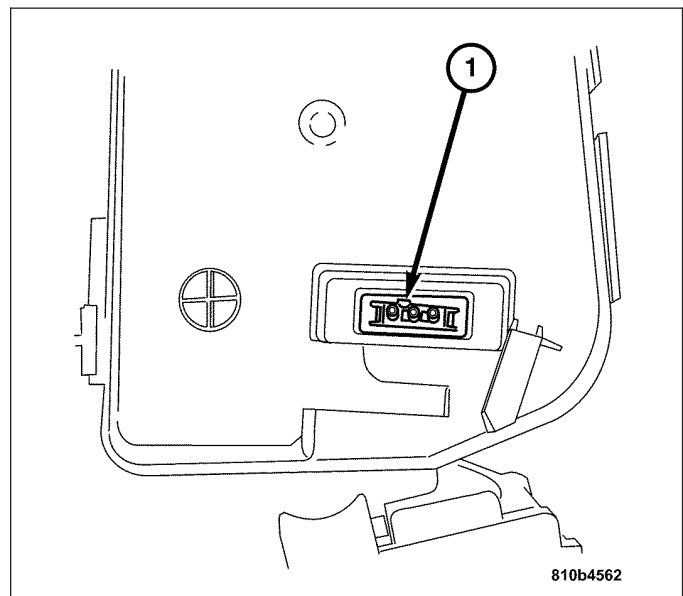

- 6. Connect the heater core temperature sensor (1).
- 7. Install the center I/P support bar to bulkhead bolts and nuts (2).

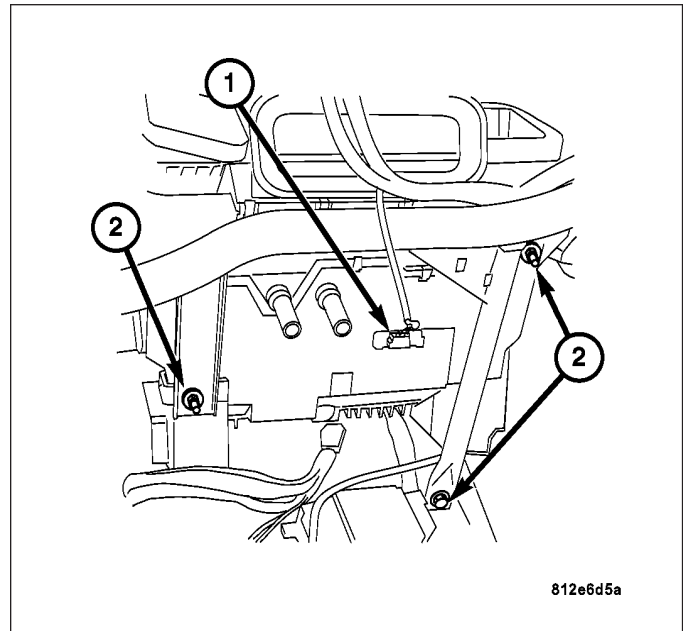

- 8. Connect the recirculated air switchover valve connector (3).
- 9. Install the vacuum reservoir then connect the vacuum reservoir solenoid connector and vacuum hose (2).
- 10. Connect the passenger side air bag harness connector (1).
- 11. Install the glove box assembly.(Refer to 23 - BODY/INSTRUMENT PANEL/INSTRUMENT PANEL ASSEMBLY - INSTALLATION).
- 12. Install the SKREEM module and mounting bracket. Then connect the SKREEM harness connectors.(Refer to 8 - ELECTRICAL/VEHICLE THEFT SECURITY/SENTRY KEY REMOTE ENTRY MODULE - INSTALLATION).

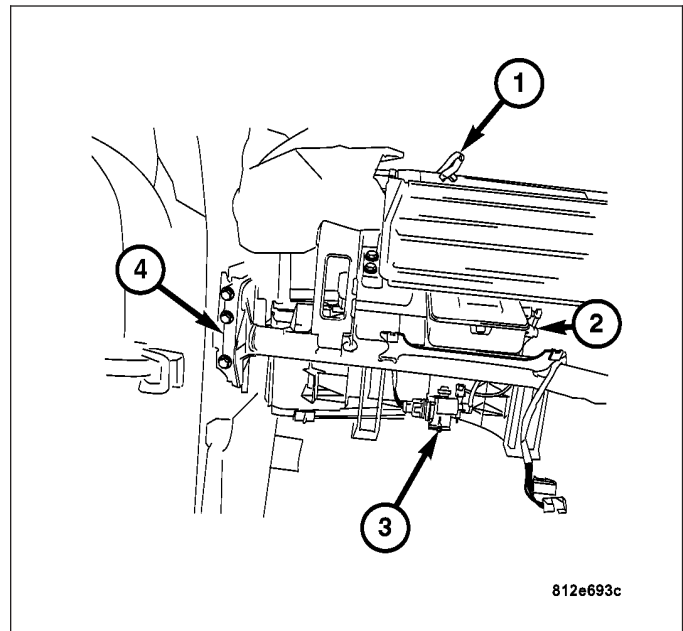

- 13. Install the instrument cluster and bracket assembly. (Refer to 23 - BODY/INSTRUMENT PANEL/INSTRUMENT PANEL ASSEMBLY - INSTALLATION).
- 14. Install the I/P top cover. (Refer to 23 - BODY/INSTRUMENT PANEL/INSTRUMENT PANEL ASSEMBLY - INSTALLATION).
- 15. Install the front and rear center consoles.(Refer to 23 - BODY/INTERIOR/CENTER CONSOLE - INSTALLATION) and (Refer to 23 - BODY/INTERIOR/CENTER CONSOLE - INSTALLATION).

R-134a refrigerant system are not compatible with the mineral-based refrigerant oils used in an R-12 refrigerant system.

R-134a refrigerant system service ports, service tool couplers and refrigerant dispensing bottles have all been designed with unique fittings to ensure that an R-134a system is not accidentally contaminated with the wrong refrigerant (R-12). There are also labels posted in the engine compartment of the vehicle and on the Compressor identifying to service technicians that the Air Conditioning System is equipped with R-134a.

REFRIGERANT OIL

DESCRIPTION

The refrigerant oil used in R-134a refrigerant systems is a synthetic-based, PolyAlkylene Glycol (PAG), wax-free lubricant. Mineral-based R-12 refrigerant oils are not compatible with PAG oils, and should never be introduced to an R-134a refrigerant system.

There are different PAG oils available, and each contains a different additive package. The 10PA17 Compressor used in this vehicle is designed to use an ND8 PAG refrigerant oil. Use only refrigerant oil of this same type to service the refrigerant system.

OPERATION

After performing any refrigerant recovery or recycling operation, always replenish the refrigerant system with the same amount of the recommended refrigerant oil as was removed. Too little refrigerant oil can cause Compressor damage, and too much can reduce air conditioning system performance.

PAG refrigerant oil is much more hygroscopic than mineral oil, and will absorb any moisture it comes into contact with, even moisture in the air. The PAG oil container should always be kept tightly capped until it is ready to be used. After use, recap the oil container immediately to prevent moisture contamination.

STANDARD PROCEDURE - REFRIGERANT OIL LEVEL

When an Air Conditioning System is assembled at the factory, all components except the Compressor are refrigerant oil free. After the refrigerant system has been charged and operated, the refrigerant oil in the Compressor is dispersed throughout the refrigerant system. The Accumulator, Evaporator, Condenser, and Compressor will each retain a significant amount of the needed refrigerant oil.

It is important to have the correct amount of oil in the refrigerant system. This ensures proper lubrication of the Compressor. Too little oil will result in damage to the Compressor. Too much oil will reduce the cooling capacity of the Air Conditioning System.

It will not be necessary to check the oil level in the Compressor or to add oil, unless there has been an oil loss. An oil loss may occur due to a rupture or leak from a refrigerant line, a connector fitting, a component, or a component seal. If a leak occurs, add 30 milliliters (1 fluid ounce) of refrigerant oil to the refrigerant system after the repair has been made. Refrigerant oil loss will be evident at the leak point by the presence of a wet, shiny surface around the leak.

Refrigerant oil must be added when an Accumulator, Evaporator Coil, or Condenser are replaced. See the Refrigerant Oil Capacities chart. When a Compressor is replaced, the refrigerant oil must be drained from the old Compressor and measured. Drain all of the refrigerant oil from the new Compressor, then fill the new Compressor with the same amount of refrigerant oil that was drained out of the old Compressor.

Refrigerant Oil Capacities		
Component	ml	fl oz
A/C System	130	4.40
Receiver Drier	70	2.37
Condenser	10	0.34
Evaporator	50	1.69
Compressor	Drain and measure the oil from the old compressor - see text.	

CLICK HERE TO **DOWNLOAD** THE COMPLETE MANUAL

- Thank you very much for reading the preview of the manual.
- You can download the complete manual from: www.heydownloads.com by clicking the link below



- Please note: If there is no response to CLICKING the link, please download this PDF first and then click on it.

CLICK HERE TO **DOWNLOAD** THE COMPLETE MANUAL