

Edition: October 2003  
 Revision: February 2004  
 Publication No. SM4E-1W22U1

**QUICK REFERENCE INDEX**

**NISSAN  
 XTERRA  
 MODEL WD22 SERIES**

<b>A GENERAL INFORMATION</b>	<b>GI General Information</b>
<b>B ENGINE</b>	<b>EM Engine Mechanical</b>
	<b>LU Engine Lubrication System</b>
	<b>CO Engine Cooling System</b>
	<b>EC Engine Control System</b>
	<b>FL Fuel System</b>
	<b>EX Exhaust System</b>
	<b>ACC Accelerator Control System</b>
<b>C TRANSMISSION/    TRANSAXLE</b>	<b>CL Clutch</b>
	<b>MT Manual Transmission</b>
	<b>AT Automatic Transmission</b>
<b>D DRIVELINE/AXLE</b>	<b>TF Transfer</b>
	<b>PR Propeller Shaft</b>
	<b>FFD Front Final Drive</b>
	<b>RFD Rear Final Drive</b>
	<b>FAX Front Axle</b>
	<b>RAX Rear Axle</b>
	<b>FSU Front Suspension</b>
<b>E SUSPENSION</b>	<b>RSU Rear Suspension</b>
	<b>WT Road Wheels &amp; Tires</b>
	<b>BR Brake System</b>
<b>F BRAKES</b>	<b>PB Parking Brake System</b>
	<b>BRC Brake Control System</b>
	<b>PS Power Steering System</b>
<b>G STEERING</b>	
<b>H RESTRAINTS</b>	<b>SB Seat Belts</b>
	<b>SRS Supplemental Restraint System (SRS)</b>
	<b>BL Body, Lock &amp; Security System</b>
<b>I BODY</b>	<b>GW Glasses, Window System &amp; Mirrors</b>
	<b>RF Roof</b>
	<b>EI Exterior &amp; Interior</b>
	<b>IP Instrument Panel</b>
	<b>SE Seat</b>
	<b>MTC Manual Air Conditioner</b>
	<b>J AIR CONDITIONER</b>
<b>K ELECTRICAL</b>	<b>SC Starting &amp; Charging System</b>
	<b>LT Lighting System</b>
	<b>DI Driver Information System</b>
	<b>WW Wiper, Washer &amp; Horn</b>
	<b>BCS Body Control System</b>
	<b>AV Audio Visual &amp; Telephone System</b>
	<b>ACS Auto Cruise Control System</b>
	<b>PG Power Supply, Ground &amp; Circuit Elements</b>
<b>L MAINTENANCE</b>	<b>MA Maintenance</b>
<b>M INDEX</b>	<b>IDX Alphabetical Index</b>

**A**  
**B**  
**C**  
**D**  
**E**  
**F**  
**G**  
**H**  
**I**  
**J**  
**K**  
**L**  
**M**

CLICK HERE TO **DOWNLOAD** THE COMPLETE MANUAL

- Thank you very much for reading the preview of the manual.
- You can download the complete manual from: [www.heydownloads.com](http://www.heydownloads.com) by clicking the link below



- Please note: If there is no response to CLICKING the link, please download this PDF first and then click on it.

CLICK HERE TO **DOWNLOAD** THE COMPLETE MANUAL

# AUTOMATIC SPEED CONTROL DEVICE (ASCD)

## 2. CHECK ASCD MOTOR ACTUATOR (MOTOR)

1. Disconnect ASCD motor actuator connector.
2. Measure resistance between ASCD motor actuator connector E80 terminal 6 and terminals 2, 3, and 5.

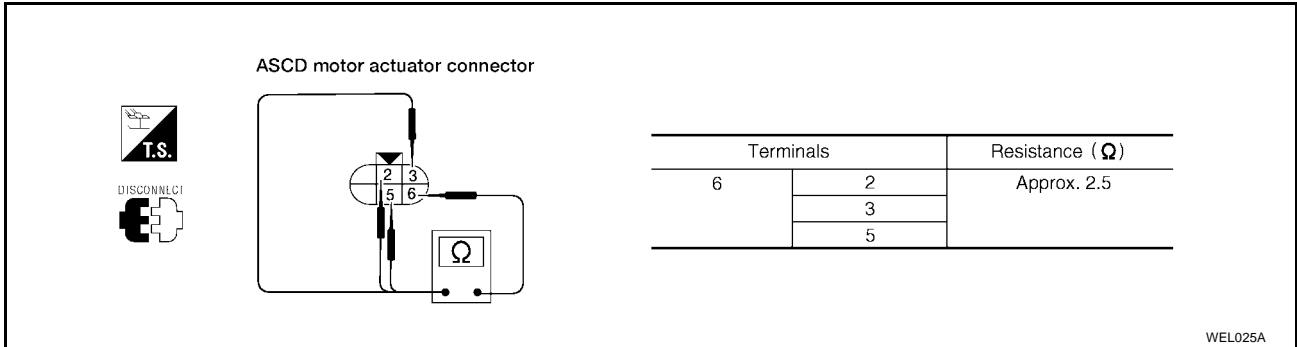

### OK or NG

OK >> Check the following.

- Harness for open or short between ASCD motor actuator and ASCD control unit
- ASCD motor actuator (clutch) ground circuit

NG >> Replace ASCD motor actuator.

A  
B  
C  
D  
E  
F  
G  
H  
I  
J  
L  
M

ACS

# OVERALL SYSTEM

## Overrun Clutch Operating Conditions

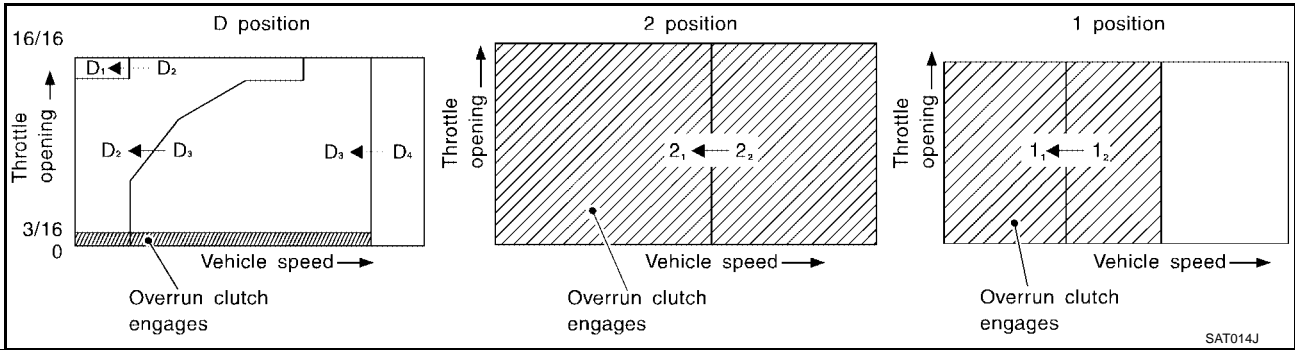

	Gear position	Throttle opening
D position	D1, D2, D3 gear position	Less than 3/16
2 position	21, 22 gear position	
1 position	11, 12 gear position	At any position

## Overrun Clutch Solenoid Valve Control

The overrun clutch solenoid valve is operated by an ON-OFF signal transmitted by the TCM to provide overrun clutch control (engine brake control).

When this solenoid valve is ON, the pilot pressure drain port closes.

When it is OFF, the drain port opens.

During the solenoid valve ON pilot pressure is applied to the end face of the overrun clutch control valve.

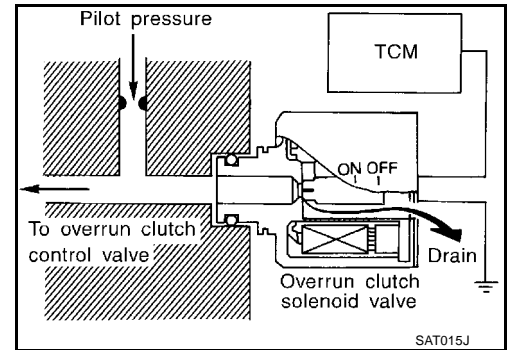

## Overrun Clutch Control Valve Operation

When the solenoid valve is ON, pilot pressure A is applied to the overrun clutch control valve. This pushes up the overrun clutch control valve. The line pressure is then shut off so that the clutch does not engage.

When the solenoid valve is OFF, pilot pressure A is not generated. At this point, the overrun clutch control valve moves downward by spring force. As a result, overrun clutch operation pressure is provided by the overrun clutch reducing valve. This causes the overrun clutch to engage.

In the 1 position, the overrun clutch control valve remains pushed down so that the overrun clutch is engaged at all times.

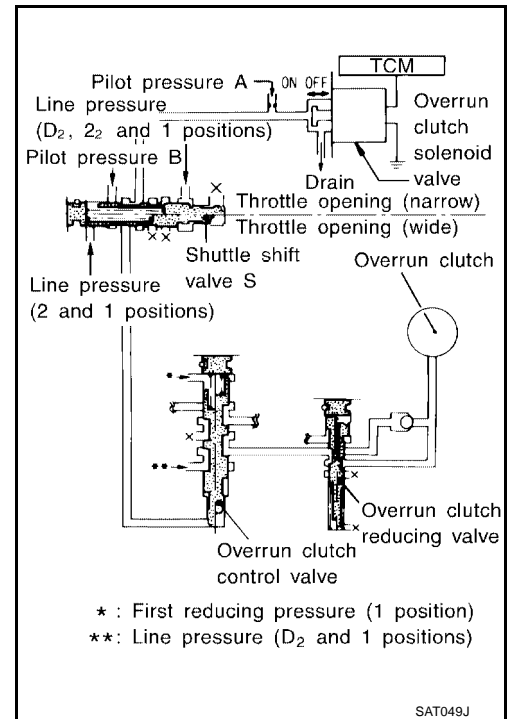

# TROUBLE DIAGNOSIS — BASIC INSPECTION

4. Set parking brake and block wheels.

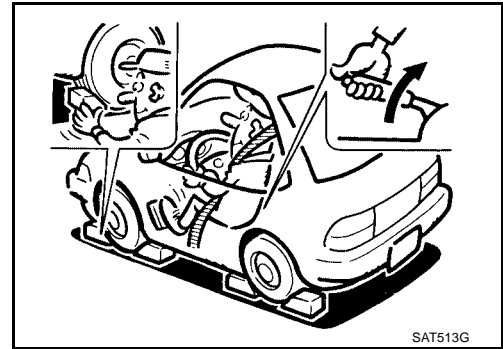

- Continue to depress brake pedal fully while line pressure test is being performed at stall speed.
5. Start engine and measure line pressure at idle and stall speed.
- When measuring line pressure at stall speed, follow the stall test procedure.

Line pressure : Refer to [AT-347, "Line Pressure"](#) .

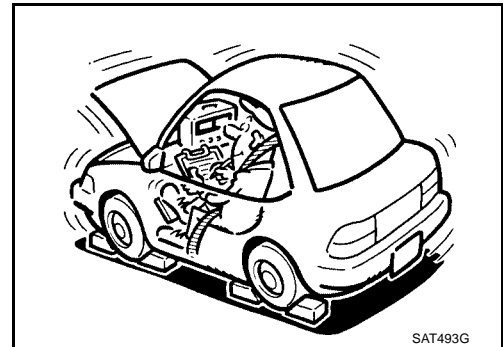

## JUDGEMENT OF LINE PRESSURE TEST

Judgement	Suspected parts	
At idle	Line pressure is low in all positions.	<ul style="list-style-type: none"> <li>● Oil pump wear</li> <li>● Control piston damage</li> <li>● Pressure regulator valve or plug sticking</li> <li>● Spring for pressure regulator valve damaged</li> <li>● Fluid pressure leakage between oil strainer and pressure regulator valve</li> <li>● Clogged strainer</li> </ul>
	Line pressure is low in particular position.	<ul style="list-style-type: none"> <li>● Fluid pressure leakage between manual valve and particular clutch</li> <li>● For example, line pressure is:                             <ul style="list-style-type: none"> <li>— Low in R and 1 positions, but</li> <li>— Normal in D and 2 positions.</li> </ul>                             Then, fluid leakage exists at or around low and reverse brake circuit. Refer to <a href="#">AT-17, "CLUTCH AND BAND CHART"</a> .                         </li> </ul>
	Line pressure is high.	<ul style="list-style-type: none"> <li>● Maladjustment of throttle position sensor</li> <li>● Fluid temperature sensor damaged</li> <li>● Line pressure solenoid valve sticking</li> <li>● Short circuit of line pressure solenoid valve circuit</li> <li>● Pressure modifier valve sticking</li> <li>● Pressure regulator valve or plug sticking</li> <li>● Open in dropping resistor circuit</li> </ul>
At stall speed	Line pressure is low.	<ul style="list-style-type: none"> <li>● Maladjustment of throttle position sensor</li> <li>● Line pressure solenoid valve sticking</li> <li>● Short circuit of line pressure solenoid valve circuit</li> <li>● Pressure regulator valve or plug sticking</li> <li>● Pressure modifier valve sticking</li> <li>● Pilot valve sticking</li> </ul>

# DTC P0705 PARK/NEUTRAL POSITION (PNP) SWITCH

Ⓜ With CONSULT-II

1. Turn ignition switch ON.

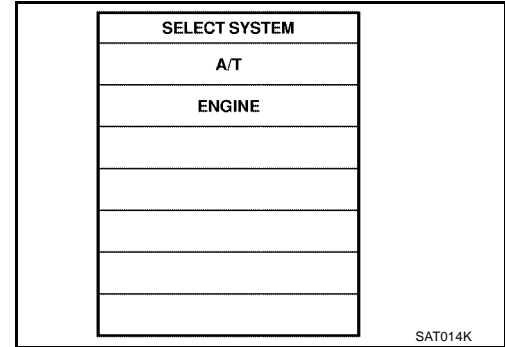

2. Select "DATA MONITOR" mode for "ENGINE" with CONSULT-II.
3. Start engine and maintain the following conditions for at least 5 consecutive seconds.  
**VHCL SPEED SE: 10 km/h (6 MPH) or more**  
**THRTL POS SEN: More than 1.3V**  
**Selector lever: D position (O/D ON or OFF)**

Ⓜ With GST

- Follow the procedure "With CONSULT-II".

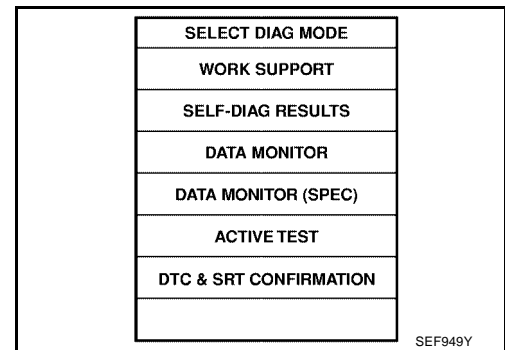

# DTC P0733 IMPROPER SHIFTING TO 3RD GEAR POSITION

## Diagnostic Procedure

ECS005NB

### 1. CHECK SHIFT SOLENOID VALVE

1. Remove control valve assembly. Refer to [AT-253, "REMOVAL"](#) .
2. Check shift solenoid valve operation.
  - Shift solenoid valve A

Refer to [AT-136, "SHIFT SOLENOID VALVE A"](#) .

OK or NG

- OK >> GO TO 2
- NG >> Repair or replace shift solenoid valve assembly.

### 2. CHECK CONTROL VALVE

1. Disassemble control valve assembly.  
Refer to [AT-283, "Disassembly"](#) .
2. Check to ensure that:
  - Valve, sleeve and plug slide along valve bore under their own weight.
  - Valve, sleeve and plug are free from burrs, dents and scratches.
  - Control valve springs are free from damage, deformation and fatigue.
  - Hydraulic line is free from obstacles.

OK or NG

- OK >> GO TO 3
- NG >> Repair control valve assembly.

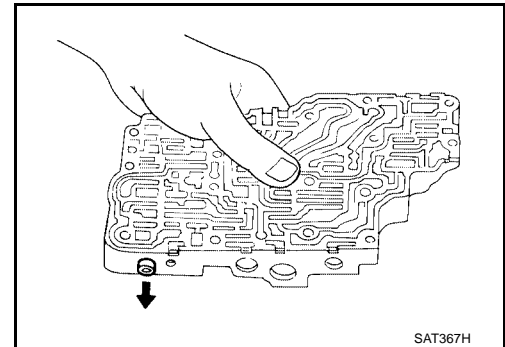

### 3. CHECK DTC

Perform Diagnostic Trouble Code (DTC) confirmation procedure. Refer to [AT-131, "DIAGNOSTIC TROUBLE CODE \(DTC\) CONFIRMATION PROCEDURE"](#) .

OK or NG

- OK >> **INSPECTION END**
- NG >> Check control valve again. Repair or replace control valve assembly.

# DTC P0755 SHIFT SOLENOID VALVE B

ECS00500

## Component Inspection SHIFT SOLENOID VALVE B

- For removal, refer to [AT-253, "REMOVAL"](#) .

### Resistance Check

- Check resistance between terminal 2 and ground.

Solenoid valve	Terminal No.		Resistance (Approx.)
Shift solenoid valve B	2	Ground	20 - 40Ω

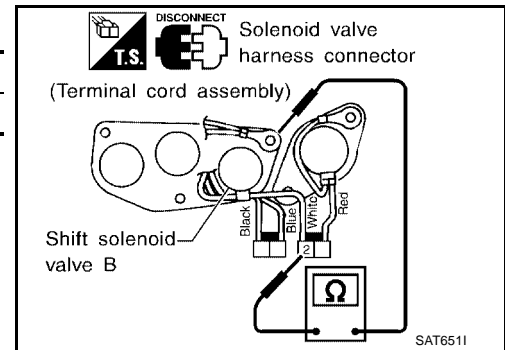

### Operation Check

- Check solenoid valve by listening for its operating sound while applying battery voltage to the terminal 2 and ground.

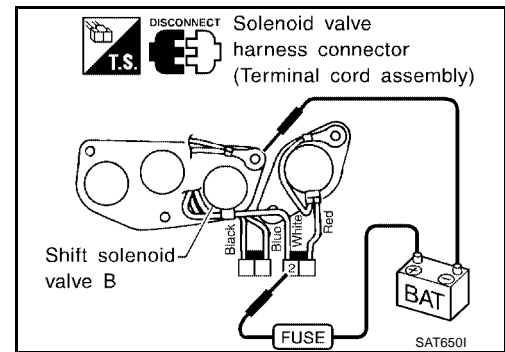

# TROUBLE DIAGNOSES FOR SYMPTOMS

## AT-NONDTC-03

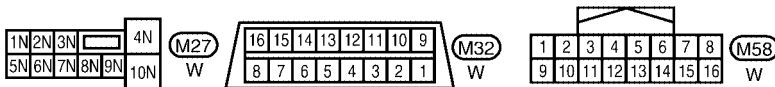
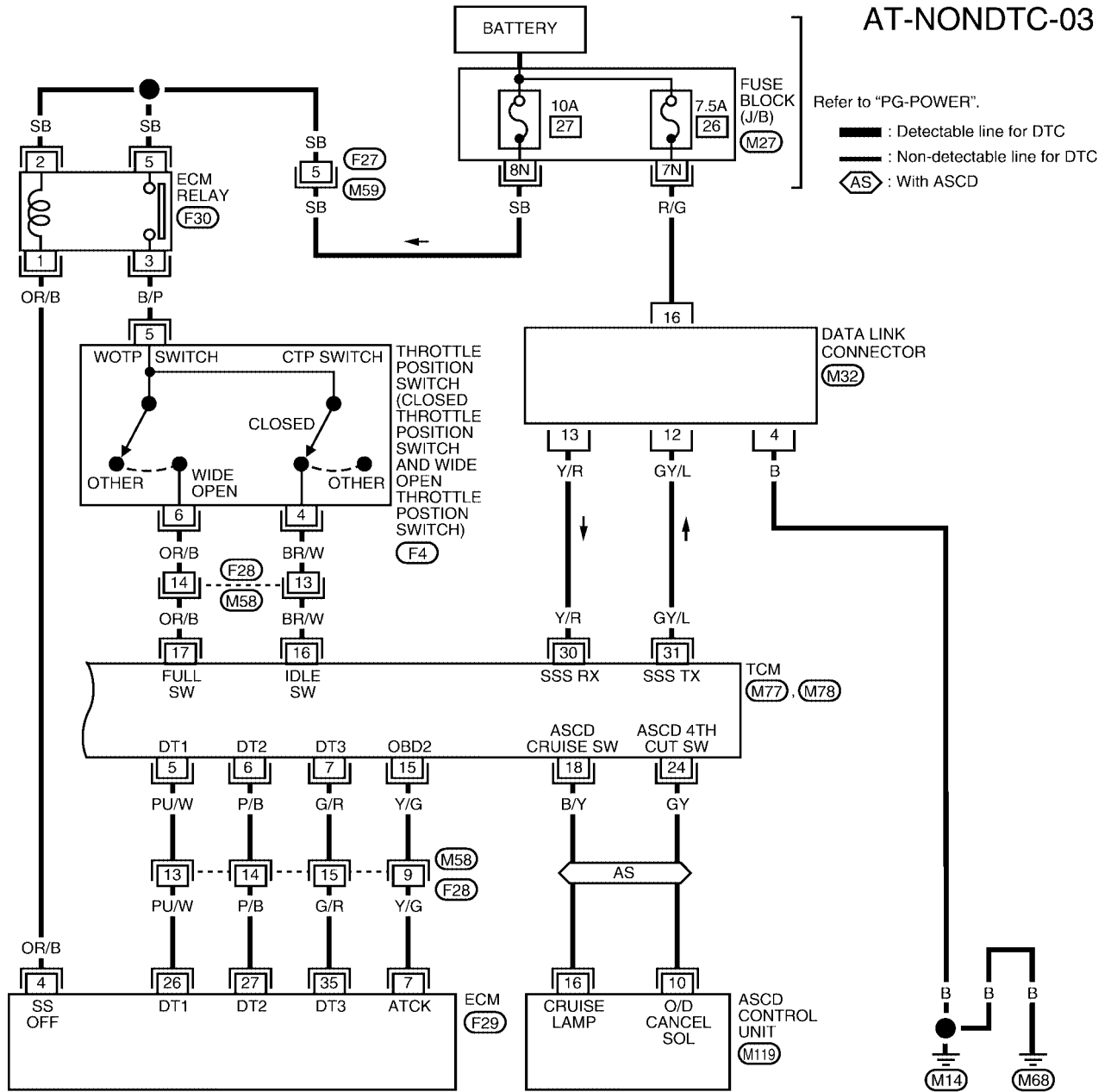

Refer to the following.  
 (F29) - ELECTRICAL UNITS

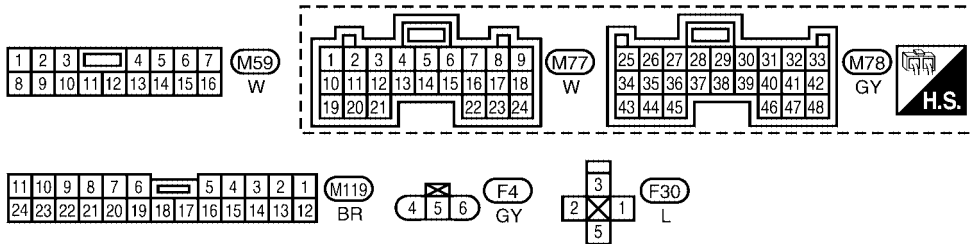

# TROUBLE DIAGNOSES FOR SYMPTOMS

## 2. CHECK PNP SWITCH CIRCUIT (WITHOUT CONSULT-II)

⊗ **Without CONSULT-II**

1. Turn ignition switch to ON position.  
(Do not start engine.)
2. Check voltage between TCM harness connector M78 terminals (26, 27, 34, 35, 36) and ground while moving selector lever through each position.

Lever position	Terminals				
	36	35	34	27	26
P, N	B	0	0	0	0
R	0	B	0	0	0
D	0	0	B	0	0
2	0	0	0	B	0
1	0	0	0	0	B

Does battery voltage exist (B) or non-existent (0)?

Yes >> GO TO 3

No >> Check the following items:

- PNP switch  
Refer to [AT-103, "PNP SWITCH"](#) .
- Harness for short or open between ignition switch and PNP switch (Main harness)
- Harness for short or open between PNP switch and TCM (Main harness)

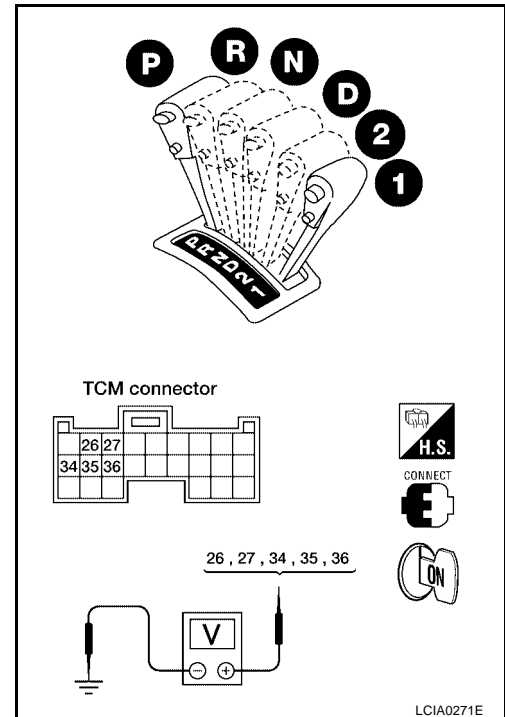

LCIA0271E

# DISASSEMBLY

22. Remove band servo and accumulator components.  
 a. Remove band servo retainer from transmission case.

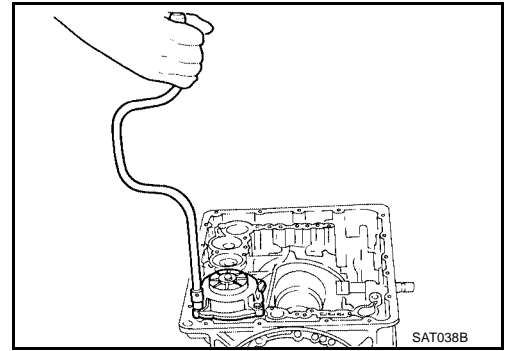

- b. Apply compressed air to oil hole until band servo piston comes out of transmission case.  
 ● Hold piston with a rag and gradually direct air to oil hole.  
 c. Remove return springs.

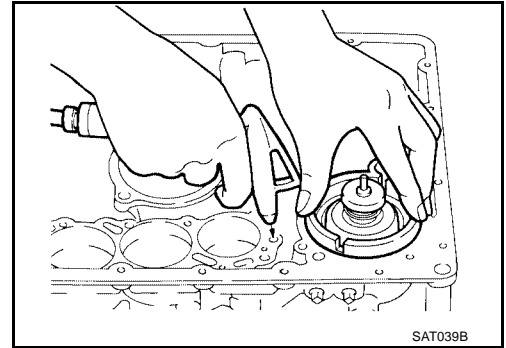

- d. Remove springs from accumulator pistons B, C and D.  
 e. Apply compressed air to each oil hole until piston comes out.  
 ● Hold piston with a rag and gradually direct air to oil hole.

Identification of accumulator pistons	A	B	C	D
Identification of oil holes	a	b	c	d

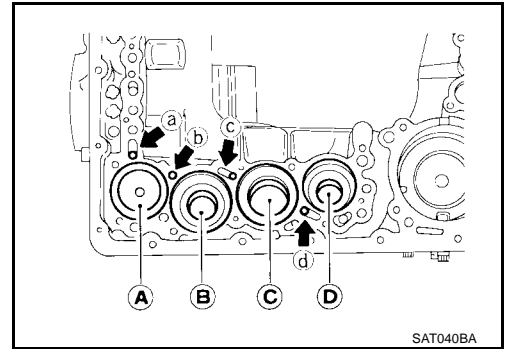

- f. Remove O-ring from each piston.

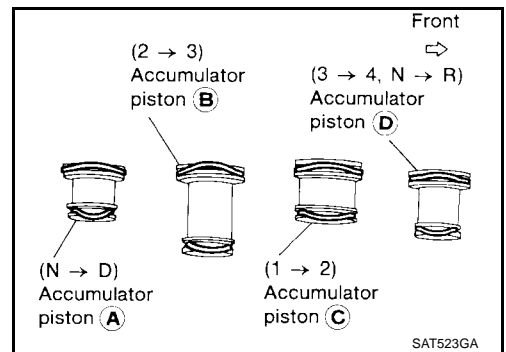

23. Remove manual shaft components, if necessary.  
 a. Hold width across flats of manual shaft (outside the transmission case) and remove lock nut from shaft.

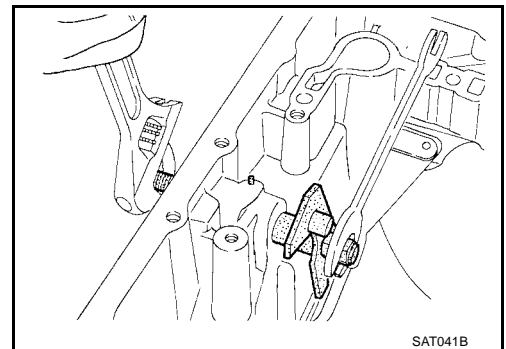

A  
B  
AT  
D  
E  
F  
G  
H  
I  
J  
K  
L  
M

## LOW & REVERSE BRAKE

3. Remove low one-way clutch inner race, spring retainer and return spring from transmission case.
4. Remove seal rings from low one-way clutch inner race.
5. Remove needle bearing from low one-way clutch inner race.

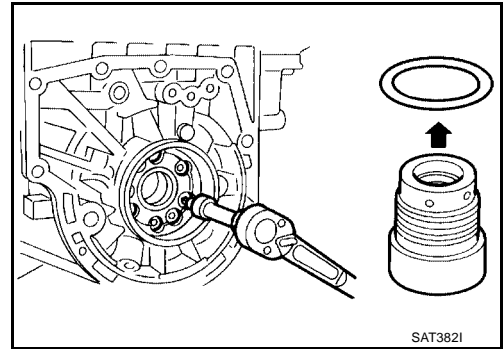

6. Remove low and reverse brake piston using compressed air.
7. Remove oil seal and D-ring from piston.

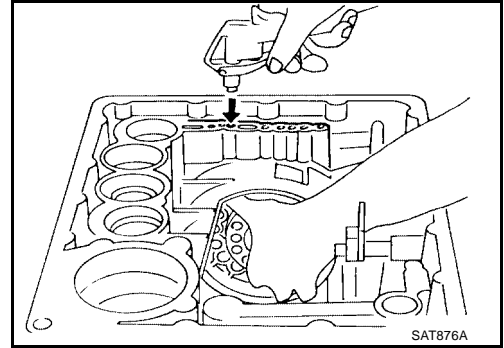

### Inspection

#### LOW AND REVERSE BRAKE SNAP RING AND SPRING RETAINER

ECS0050I

- Check for deformation, or damage.

#### LOW AND REVERSE BRAKE RETURN SPRINGS

- Check for deformation or damage. Also measure free length and outside diameter.

**Inspection standard** : Refer to [AT-347, "Return Springs"](#).

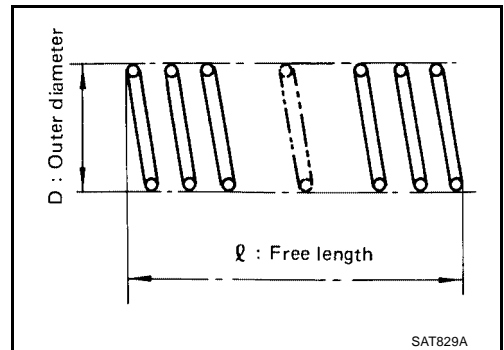

#### LOW AND REVERSE BRAKE DRIVE PLATES

- Check facing for burns, cracks or damage.
- Measure thickness of facing.

**Thickness of drive plate:**

**Standard value** : 1.52 - 1.67 mm (0.0598 - 0.0657 in)

**Wear limit** : 1.40 mm (0.0551 in)

- If not within wear limit, replace.

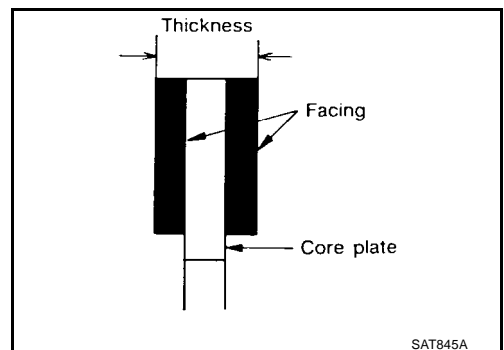

# ASSEMBLY

- d. Tighten bolts while inserting 4.0 mm (0.157 in) dia. pin vertically into locating holes in park/neutral position (PNP) switch and manual shaft.

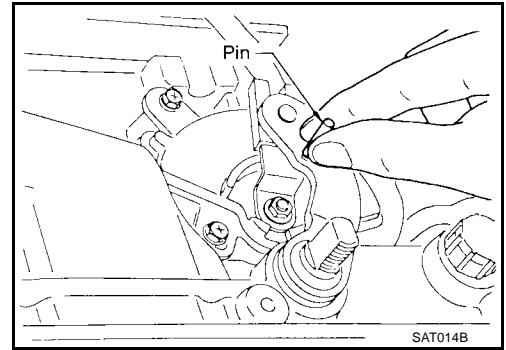

13. Install torque converter.

- a. Pour ATF into torque converter.

- Approximately 2 ℓ (2-1/8 US qt, 1-3/4 Imp qt) of fluid are required for a new torque converter.
- When reusing old torque converter, add the same amount of fluid as was drained.

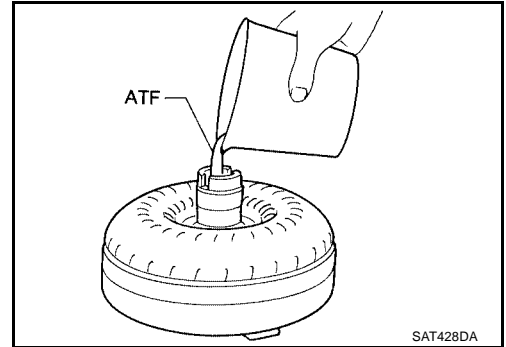

- b. Install torque converter while aligning notches and oil pump.

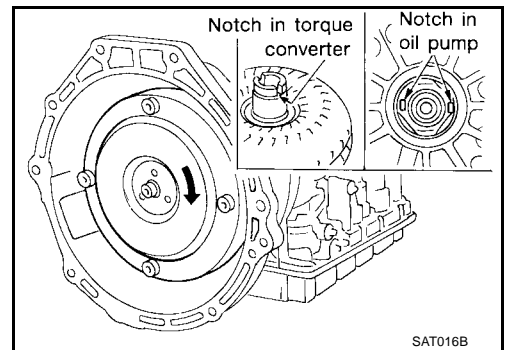

- c. Measure distance A to check that torque converter is in proper position.

**Distance "A":**

**VG33E**

**: 26.0 mm (1.024 in) or more**

**VG33ER**

**: 25.0 mm (0.984 in) or more**

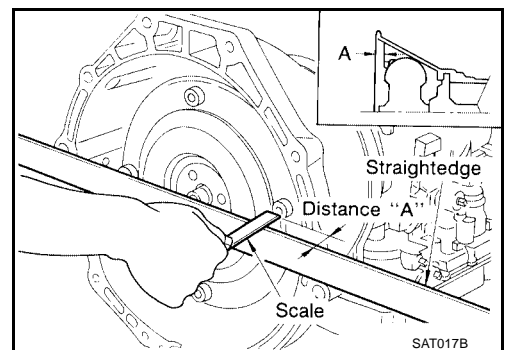

A  
B  
AT  
D  
E  
F  
G  
H  
I  
J  
K  
L  
M



# REMOTE KEYLESS ENTRY SYSTEM

## Circuit Diagram

EIS00137

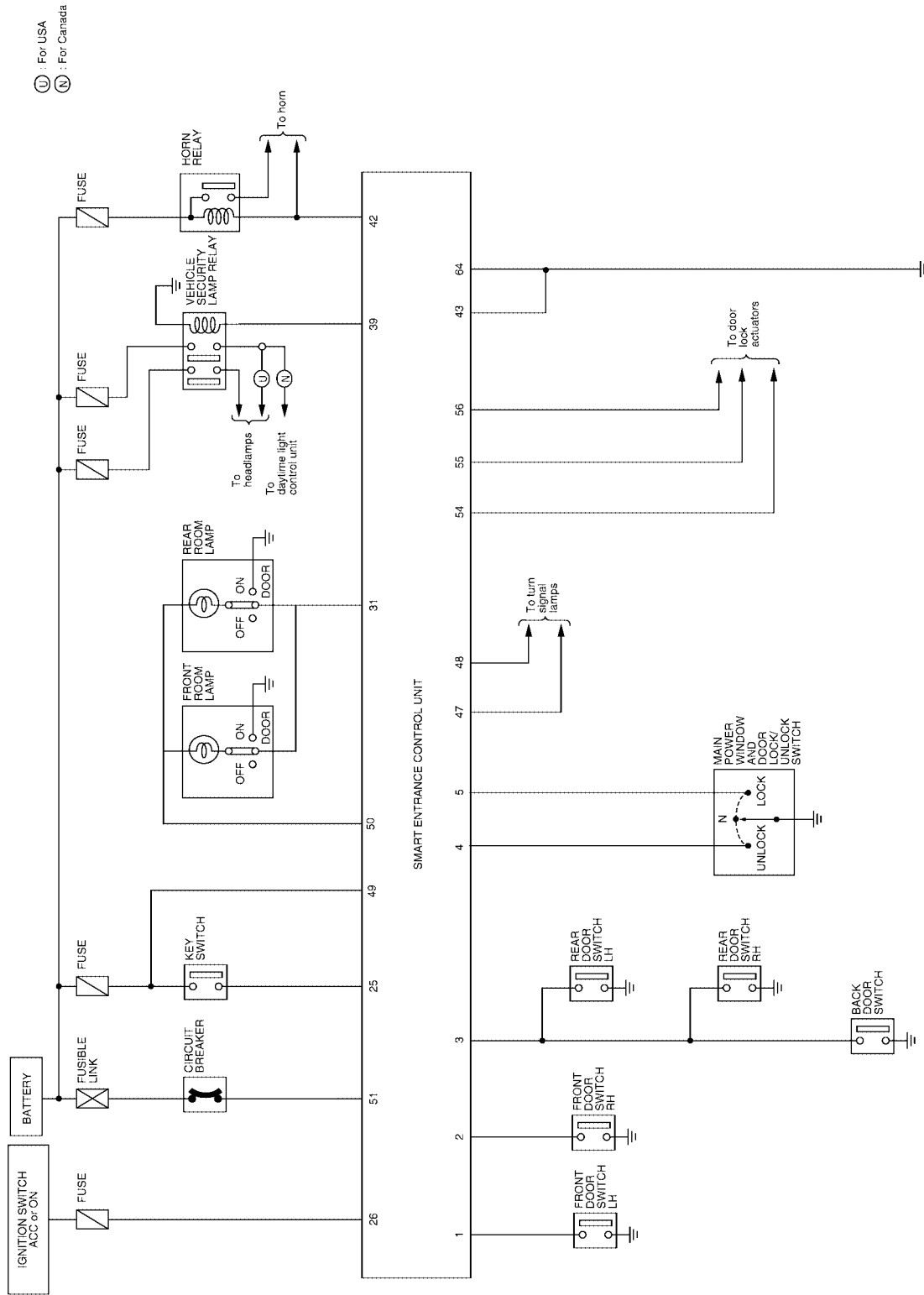

A  
B  
C  
D  
E  
F  
G  
H  
BL  
J  
K  
L  
M

WIWA0128E

# BODY (ALIGNMENT)

PFP:74312

## BODY (ALIGNMENT)

EIS0013I

### Alignment

- All dimensions indicated in the figures are actual.
- When using a tracking gauge, adjust both pointers to equal length, then check pointers and the gauge to make sure there is no free play.
- When a measuring tape is used, check to be sure there is no elongation, twisting or bending.
- Measurements should be taken at the center of the mounting holes.
- An asterisk (\*) following the value at the measuring point indicates that the measuring point on the other side is symmetrically the same value.
- The coordinates of the measurement points are the distances measured from the standard line of "X", "Y" and "Z".

(LH) : LH side

(RH) : RH side

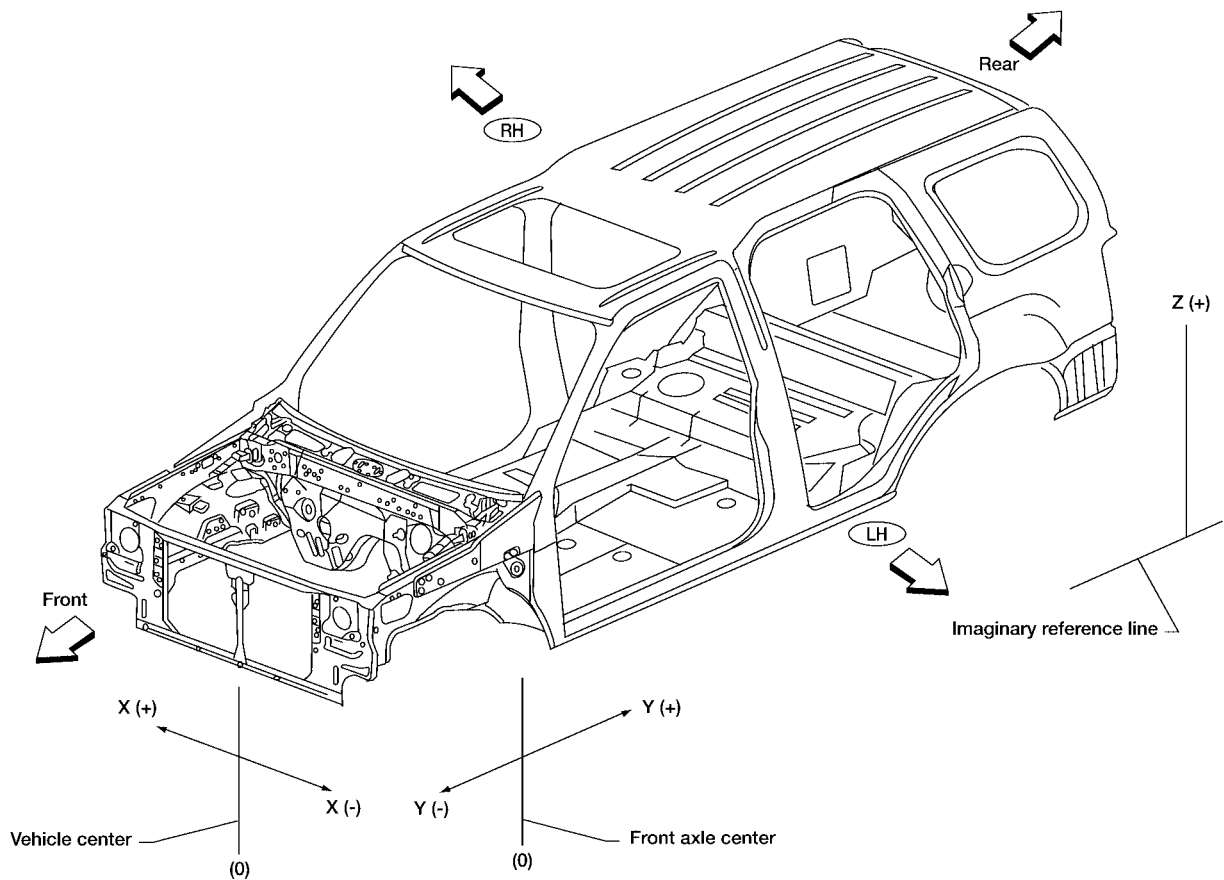

X" : Vehicle center

Y" : Center line of front axle

Z" : Imaginary reference line  
[300mm below datum line  
("0Z" at design plan)]

WBT184

# REAR DRUM BRAKE

**CAUTION:**  
Be careful not to damage wheel cylinder piston boots.

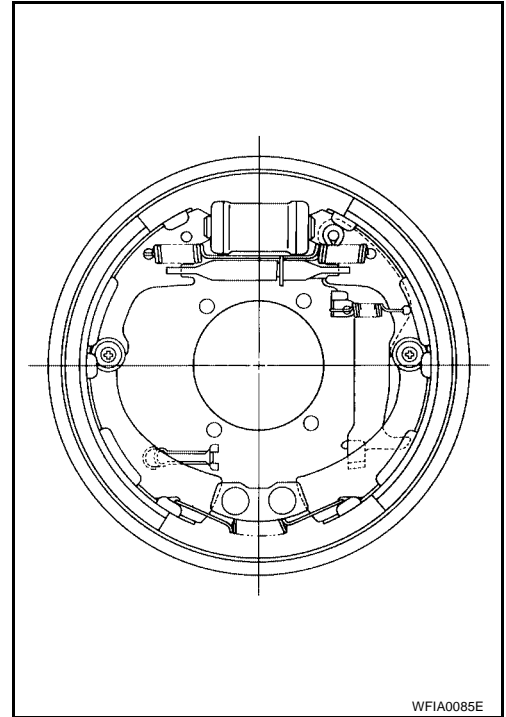

5. Adjust shoe-to-drum clearance.
6. Install brake drum.
7. When installing new wheel cylinder or overhauling wheel cylinder, bleed air. Refer to [BR-9, "Bleeding Brake System"](#).
8. Adjust parking brake. Refer to [PB-3, "Adjustment"](#).

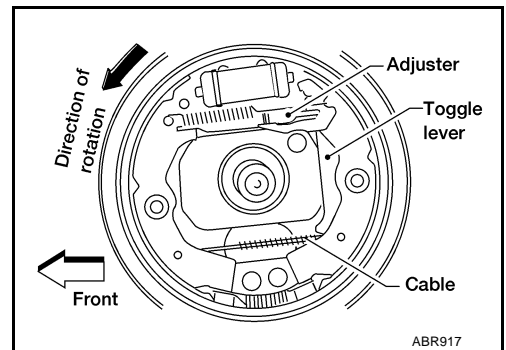

## Wheel Cylinder Disassembly and Assembly

- Check all internal parts for wear, rust and damage. Replace if necessary.
- Pay attention not to scratch cylinder when installing pistons.

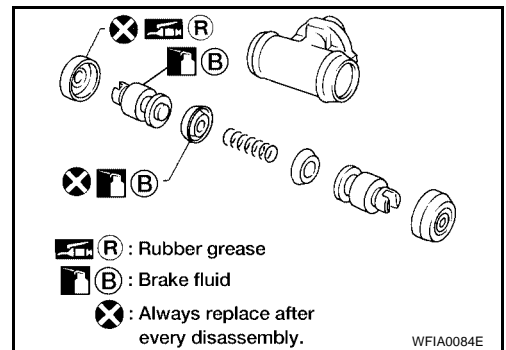

# TROUBLE DIAGNOSIS

**[ABS]**

Operation		ABS solenoid valve			ABS solenoid valve (ACT)		
		UP	KEEP	DOWN	UP	ACT UP	ACT KEEP
FR LH SOL FR LH ABS SOLE- NOID (ACT)	FR LH IN SOL	OFF	ON	ON	OFF	OFF	OFF
	FR LH OUT SOL	OFF	OFF	ON*	OFF	OFF	OFF
RR RH SOL RR RH ABS SOLE- NOID (ACT)	RR RH IN SOL	OFF	ON	ON	OFF	OFF	OFF
	RR RH OUT SOL	OFF	OFF	ON*	OFF	OFF	OFF
RR LH SOL RR LH ABS SOLE- NOID (ACT)	RR LH IN SOL	OFF	ON	ON	OFF	OFF	OFF
	RR LH OUT SOL	OFF	OFF	ON*	OFF	OFF	OFF

\*: ON for 1 to 2 seconds after the touch, and then OFF

**NOTE:**

- If active test is performed with brake pedal depressed, pedal stroke may change. This is normal.
- "TEST IS STOPPED" is displayed approximately 10 seconds after operation starts.
- After "TEST IS STOPPED" is displayed, to perform test again, repeat Active Test Step 6.

**ABS Motor**

Touch "ON" and "OFF" on the screen. Check that ABS motor relay operates as shown in table below.

Operation	ON	OFF
ABS actuator relay	ON	ON
ABS motor relay	ON	OFF

**NOTE:**

- If active test is performed with brake pedal depressed, pedal stroke may change. This is normal.
- "TEST IS STOPPED" is displayed approximately 10 seconds after operation starts.

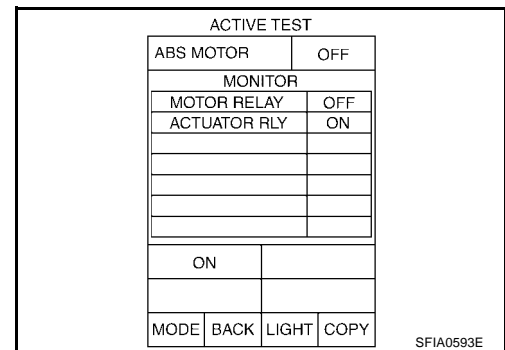

# TROUBLE DIAGNOSIS

[VDC/TCS/ABS]

BRC-VDC-02

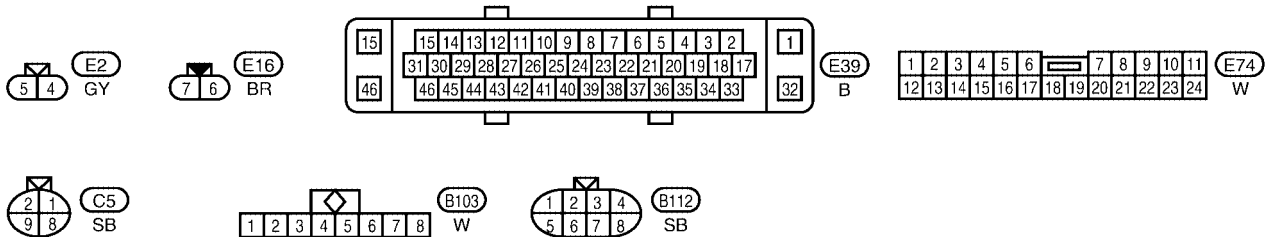
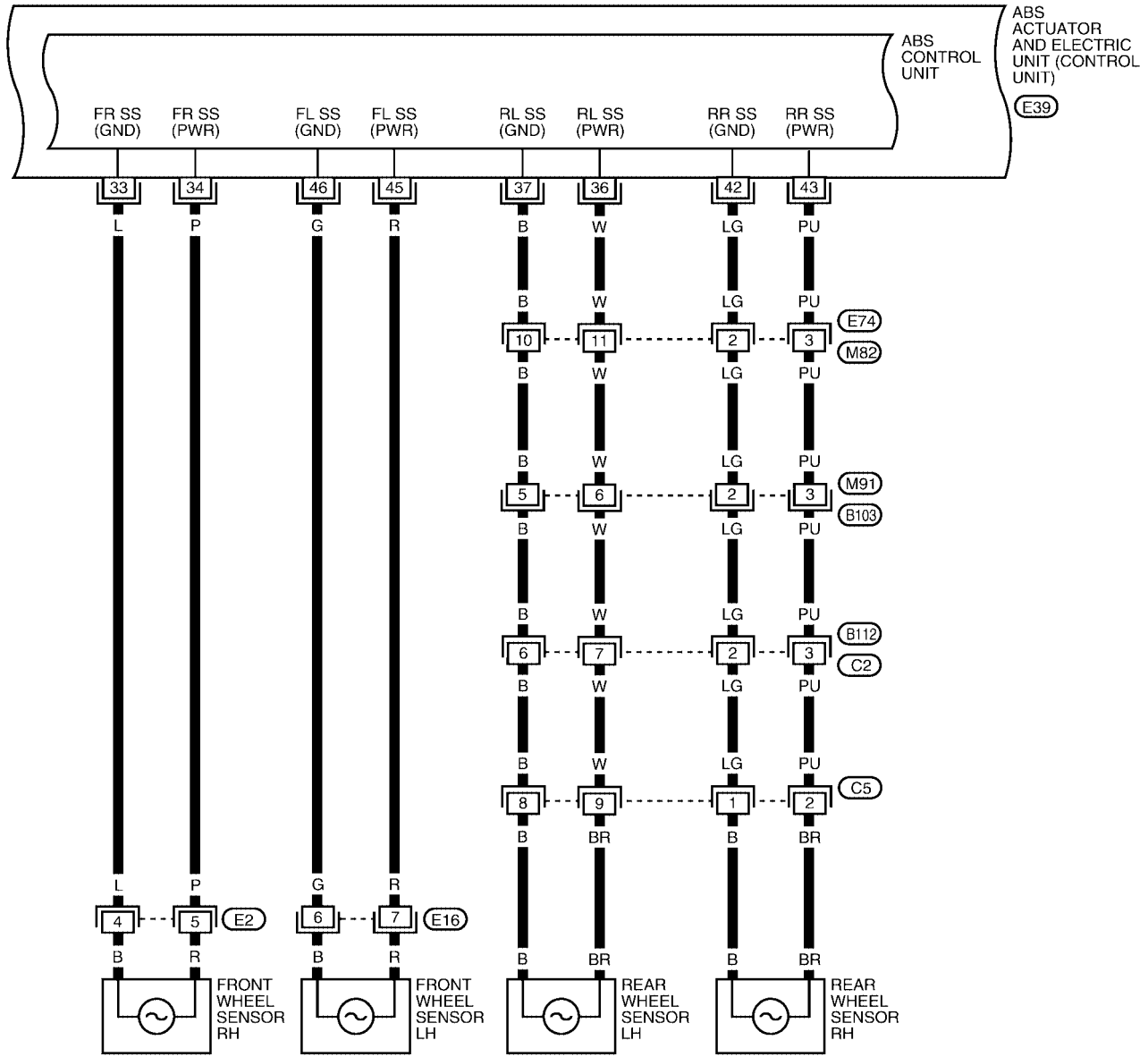

LFWA0042E

**3. CHECKING ABS MOTOR AND MOTOR RELAY POWER SYSTEM**

1. Disconnect ABS actuator and electric unit (control unit) connector.
2. Check voltage between ABS actuator and electric unit (control unit) connector E39 and body ground.

ABS actuator and electric unit (control unit) (Harness connector E39)	Body ground	Voltage (V) (Approx.)
1 (L)	—	12

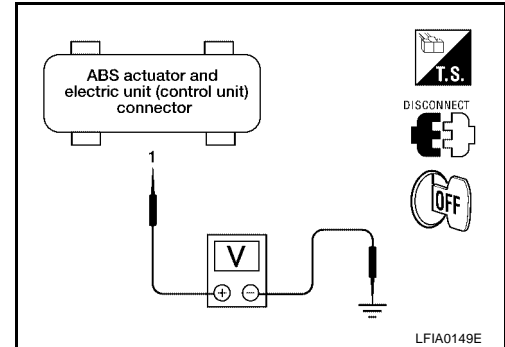

3. Check resistance between ABS actuator and electric unit (control unit) connector E39 and ground.

ABS actuator and electric unit (control unit) (Harness connector E39)	Body ground	Resistance value (Ω) (Approx.)
16 (B), 47 (B)	—	0

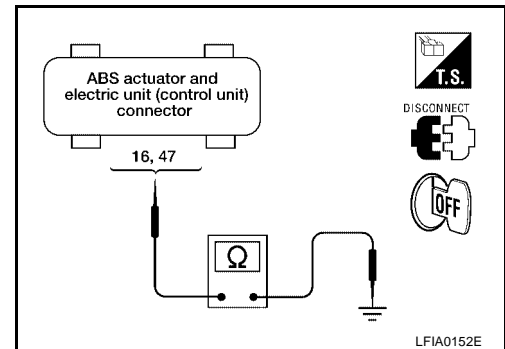

Is inspection result OK?

YES >> Perform self-diagnosis again. If the same result appears, replace ABS actuator and electric unit (control unit). Refer to [BRC-130, "ABS Actuator and Electric Unit"](#).

NO >> Repair harness or connectors.

**Inspection 8 Stop Lamp Switch and Circuit**

EFS002D8

**DTC C1116**

Inspection Procedure

**1. CHECKING SELF-DIAGNOSIS RESULTS**

Check self-diagnosis results.

Self-diagnosis results
CONSULT-II display items
STOP LAMP SW

Does "STOP LAMP SW" appear in self-diagnosis results display?

YES >> GO TO 2.

NO >> Inspection is completed.

**2. CHECKING STOP LAMP**

1. Disconnect stop lamp switch connector and ABS actuator and electric unit (control unit) connector.
2. Reconnect connectors securely.
3. Start engine.
4. Repeat pumping brake pedal carefully several times, then perform self-diagnosis again.

Do any self-diagnosis items appear?

YES >> GO TO 3.

NO >> Poor connection. Repair or replace the applicable connector.

# CLUTCH SYSTEM — HYDRAULIC TYPE

## CLUTCH SYSTEM — HYDRAULIC TYPE

PF30502

### Components

ECS006HI

SEC. 300 • 305 • 306 • 465

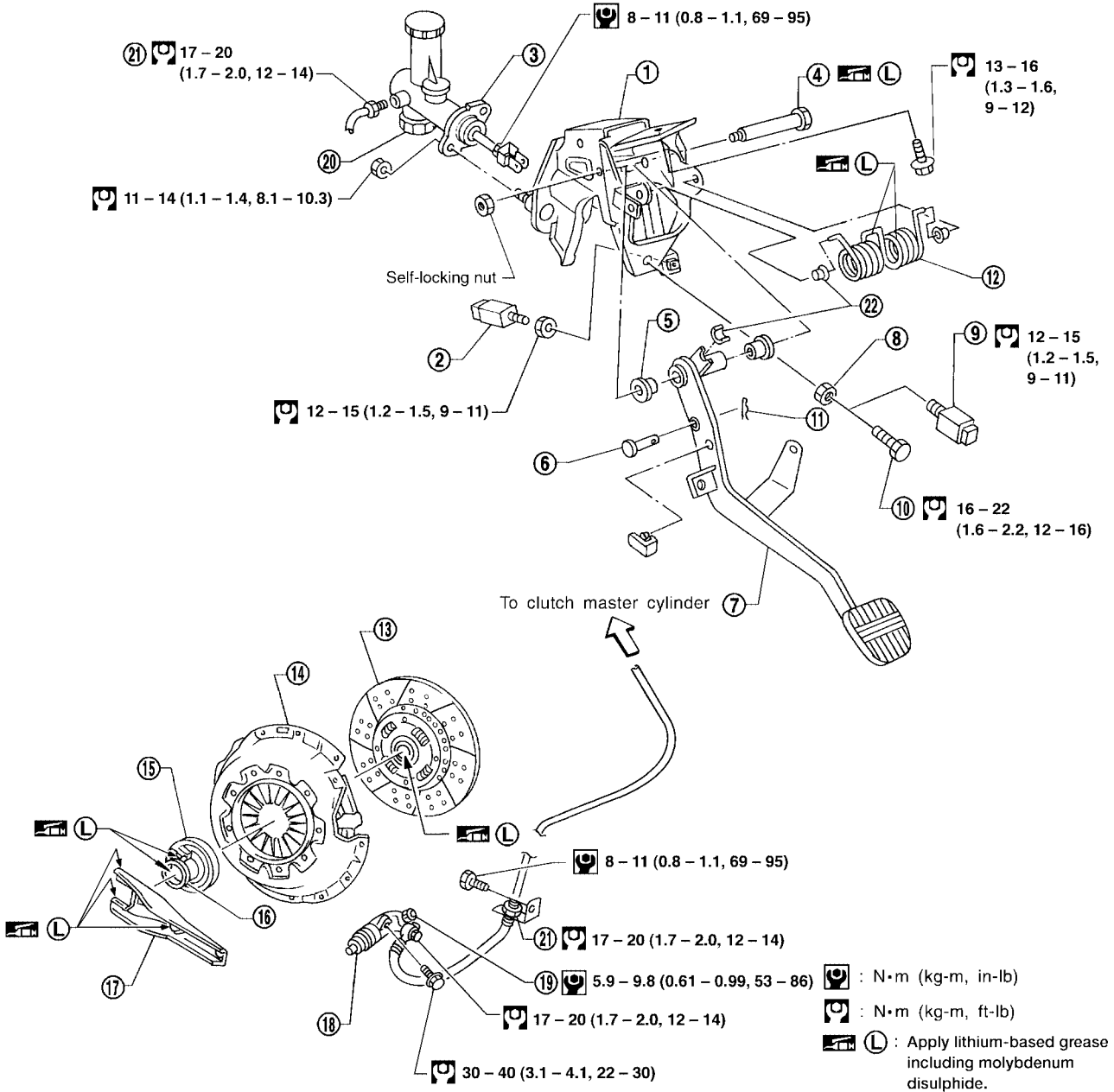

- |                                       |                                     |                           |
|---------------------------------------|-------------------------------------|---------------------------|
| 1. Clutch pedal bracket               | 2. Clutch interlock switch          | 3. Clutch master cylinder |
| 4. Fulcrum pin                        | 5. Bushing                          | 6. Clevis pin             |
| 7. Clutch pedal                       | 8. Lock nut                         | 9. ASCD clutch switch     |
| 10. Pedal stopper bolt (without ASCD) | 11. Snap pin                        | 12. Assist spring         |
| 13. Clutch disc                       | 14. Clutch cover                    | 15. Release bearing       |
| 16. Release bearing sleeve            | 17. Withdrawal lever                | 18. Operating cylinder    |
| 19. Air bleeder                       | 20. Clutch damper (not serviceable) | 21. Flare nut             |
| 22. Bushing                           |                                     |                           |

WCL044

## ENGINE COOLANT

[VG33E and VG33ER]

- Pull the negative pressure valve to open it.  
Check that it closes completely when released.

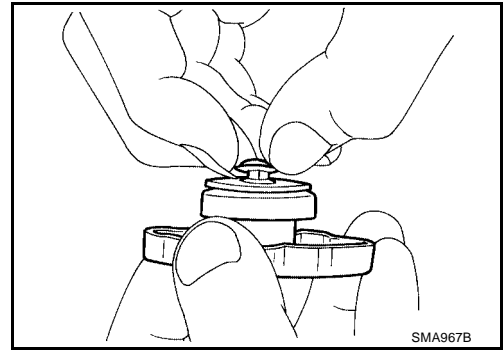

### Refilling Engine Coolant

EBS00F00

For details on refilling the engine cooling system, refer to [MA-26, "REFILLING ENGINE COOLANT"](#) .

# WARNING LAMPS

DI-WARN-05

- 4A : With 4-wheel drive and A/T
- A : With A/T
- AS : With ASCD
- XK : Except KA24DE

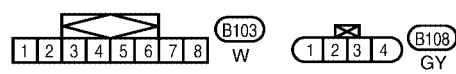
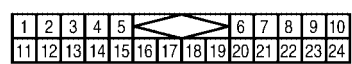
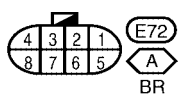
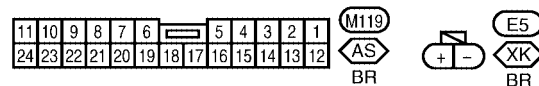
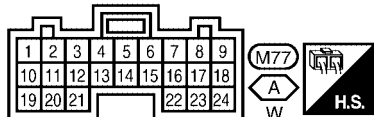
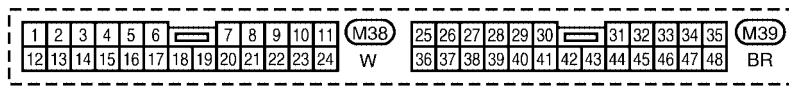
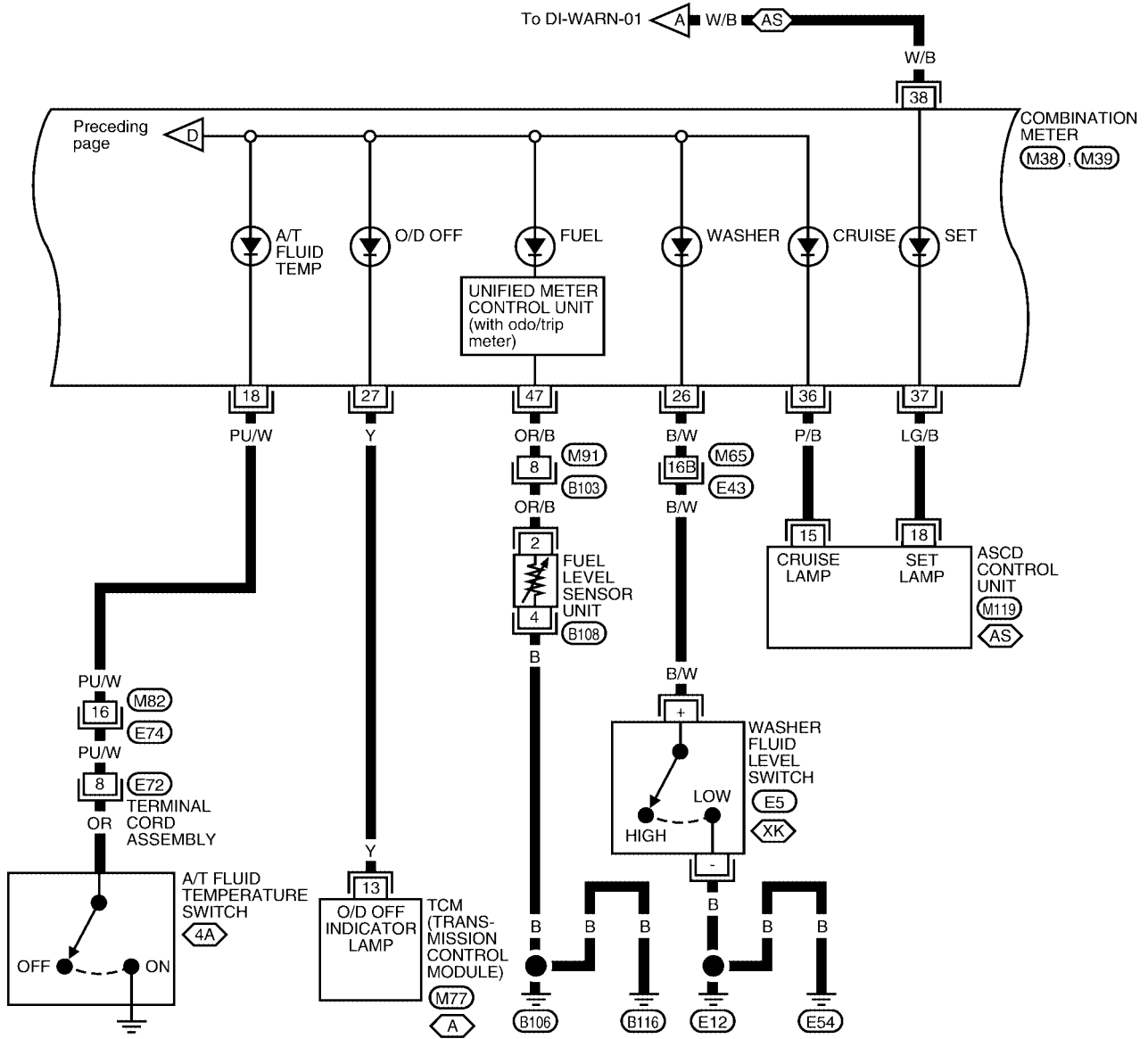

Refer to the following.  
 E43 - SUPER MULTIPLE JUNCTION (SMJ)

# INDEX FOR DTC

[KA24DE]

DTC*1 *2	Items (CONSULT-II screen terms)	Trip	MIL lighting up	Reference page
CONSULT-II GST				
P0303	CYL3 MISFIRE	2	×	<a href="#">EC-256</a>
P0304	CYL4 MISFIRE	2	×	<a href="#">EC-256</a>
P0327	KNOCK SEN/CIRC-B1	1	—	<a href="#">EC-263</a>
P0328	KNOCK SEN/CIRC-B1	1	—	<a href="#">EC-263</a>
P0335	CKP SEN/CIRCUIT	2	×	<a href="#">EC-267</a>
P0340	CMP SEN/CIRCUIT	2	×	<a href="#">EC-273</a>
P0400	EGR SYSTEM	2	×	<a href="#">EC-280</a>
P0402	EGRC-BPT VALVE	2	×	<a href="#">EC-291</a>
P0405	EGR TEMP SEN/CIRC	2	×	<a href="#">EC-297</a>
P0406	EGR TEMP SEN/CIRC	2	×	<a href="#">EC-297</a>
P0420	TW CATALYST SYS-B1	2	×	<a href="#">EC-304</a>
P0441	EVAP PURG FLOW/MON	2	×	<a href="#">EC-309</a>
P0442	EVAP SMALL LEAK	2	×	<a href="#">EC-318</a>
P0444	PURG VOLUME CONT/V	2	×	<a href="#">EC-331</a>
P0445	PURG VOLUME CONT/V	2	×	<a href="#">EC-331</a>
P0447	VENT CONTROL VALVE	2	×	<a href="#">EC-337</a>
P0452	EVAP SYS PRES SEN	2	×	<a href="#">EC-343</a>
P0453	EVAP SYS PRES SEN	2	×	<a href="#">EC-350</a>
P0455	EVAP GROSS LEAK	2	×	<a href="#">EC-360</a>
P0456	EVAP VERY SML LEAK	2	×	<a href="#">EC-371</a>
P0460	FUEL LEV SEN SLOSH	2	×	<a href="#">EC-382</a>
P0461	FUEL LEVEL SENSOR	2	×	<a href="#">EC-386</a>
P0462	FUEL LEVL SEN/CIRC	2	×	<a href="#">EC-388</a>
P0463	FUEL LEVL SEN/CIRC	2	×	<a href="#">EC-388</a>
P0500	VEH SPEED SEN/CIRC	2	×	<a href="#">EC-392</a>
P0505	ISC SYSTEM/CIRC	2	×	<a href="#">EC-397</a>
P0506	ISC SYSTEM	2	×	<a href="#">EC-402</a>
P0507	ISC SYSTEM	2	×	<a href="#">EC-407</a>
P0510	CLOSED TP SW/CIRC	2	×	<a href="#">EC-412</a>
P0605	ECM	2	×	<a href="#">EC-419</a>
P1143	HO2S1 (B1)	2	×	<a href="#">EC-421</a>
P1144	HO2S1 (B1)	2	×	<a href="#">EC-426</a>
P1146	HO2S2 (B1)	2	×	<a href="#">EC-431</a>
P1147	HO2S2 (B1)	2	×	<a href="#">EC-438</a>
P1148	CLOSED LOOP-B1	1	×	<a href="#">EC-445</a>
P1217	ENG OVER TEMP	1	×	<a href="#">EC-447</a>
P1336	CKP SENSOR (COG)	2	×	<a href="#">EC-451</a>
P1400	EGRC SOLENOID/V	2	×	<a href="#">EC-456</a>
P1402	EGR SYSTEM	2	×	<a href="#">EC-462</a>
P1442	EVAP SMALL LEAK	2	×	<a href="#">EC-471</a>
P1444	PURG VOLUME CONT/V	2	×	<a href="#">EC-473</a>
P1446	VENT CONTROL VALVE	2	×	<a href="#">EC-482</a>

## SRT Service Procedure

If a vehicle has been rejected for the State emissions inspection due to one or more SRT items indicating "INCMP", review the following flowchart diagnostic sequence.

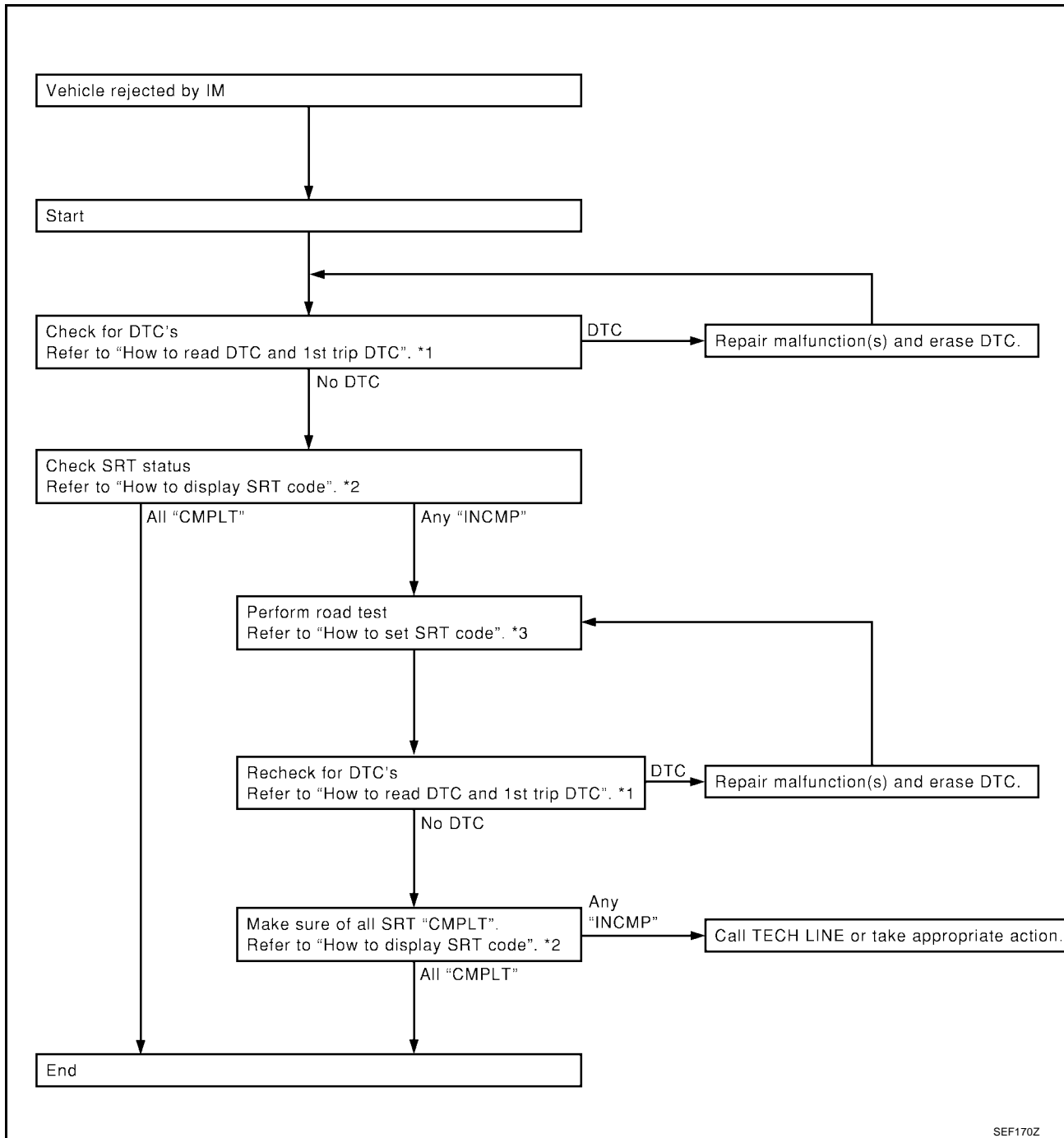

\*1 [EC-51](#)

\*2 [EC-55](#)

\*3 [EC-56](#)

SEF170Z

### How to Display SRT Code

#### With CONSULT-II

Selecting "SRT STATUS" in "DTC CONFIRMATION" mode with CONSULT-II.

For items whose SRT codes are set, a "CMPLT" is displayed on the CONSULT-II screen; for items whose SRT codes are not set, "INCMP" is displayed.

A sample of CONSULT-II display for SRT code is shown below.

## ECM Harness Connector Terminal Layout

UBS008MK

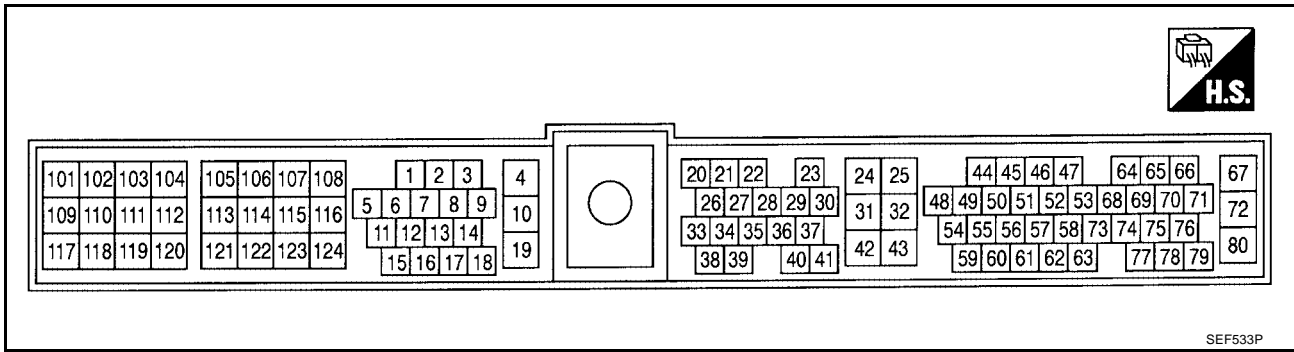

SEF533P

## ECM Terminals and Reference Value

### PREPARATION

UBS008ML

1. ECM is located behind the instrument lower cover. For this inspection:

- Remove instrument lower cover.

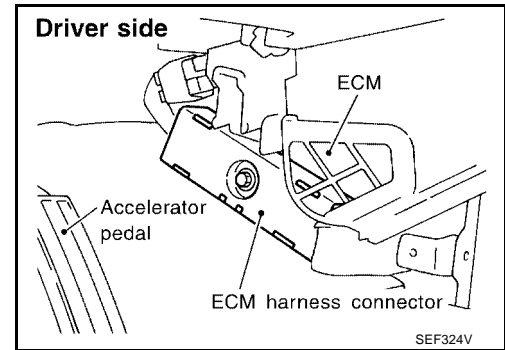

2. Remove ECM harness protector.

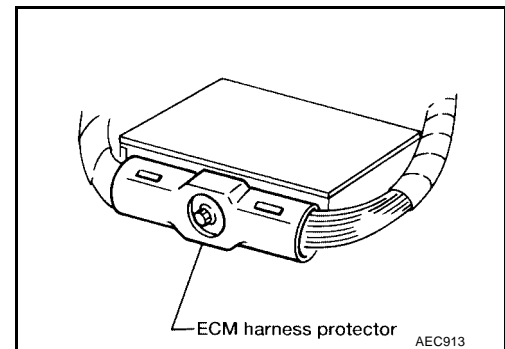

3. Perform all voltage measurements with the connector connected. Extend tester probe as shown to perform tests easily.

- Open harness securing clip to make testing easier.
- Use extreme care not to touch 2 pins at 1 time.
- Data is for comparison and may not be exact.

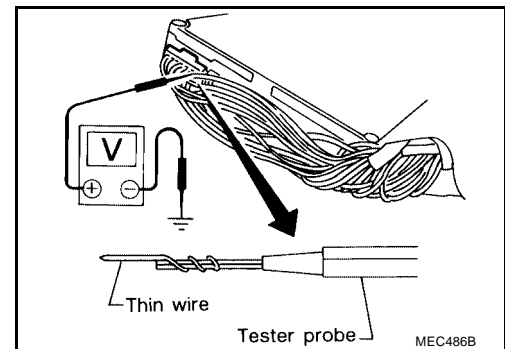

## ECM INSPECTION TABLE

Specification data are reference values and are measured between each terminal and ground.

### CAUTION:

**Do not use ECM ground terminals when measuring input/output voltage. Doing so may result in damage to the ECM's transistor. Use a ground other than ECM terminals, such as the ground.**

**14. CHECK GROUND CONNECTIONS**

1. Turn ignition switch OFF.
2. Loosen and retighten ground screw.  
Refer to [EC-126, "Ground Inspection"](#) .

OK or NG

- OK >> GO TO 15.  
NG >> Repair or replace ground connections.

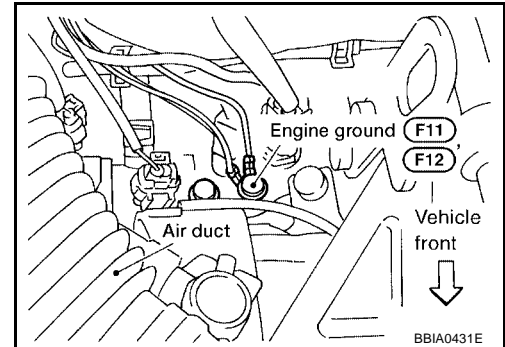
**15. CHECK GROUND CIRCUIT**

1. Turn ignition switch OFF.
2. Disconnect ECM harness connector.
3. Check harness continuity between ECM terminals 10, 19, 25, 32, 116, 124 and ground.  
Refer to Wiring Diagram.

**Continuity should exist.**

4. Also check harness for short to power.

OK or NG

- OK >> GO TO 16.  
NG >> Repair open circuit or short to power in harness or connectors.

**16. CHECK INTERMITTENT INCIDENT**

Perform [EC-119, "TROUBLE DIAGNOSIS FOR INTERMITTENT INCIDENT"](#) .

>> **INSPECTION END.**

## 4. CHECK GROUND CIRCUIT

1. Turn ignition switch OFF.
2. Disconnect ECM harness connector.
3. Check harness continuity between engine coolant temperature sensor terminal 2 and ECM terminal 43. Refer to Wiring Diagram.

**Continuity should exist.**

4. Also check harness for short to ground and short to power.

OK or NG

- OK    >> GO TO 5.  
 NG    >> GO TO 4.

## 5. DETECT MALFUNCTIONING PART

Check the harness for open or short between ECM and engine coolant temperature sensor.

>> Repair open circuit or short to ground or short to power in harness or connectors.

## 6. CHECK ENGINE COOLANT TEMPERATURE SENSOR

Refer to [EC-160, "Component Inspection"](#) .

OK or NG

- OK    >> GO TO 7.  
 NG    >> Replace engine coolant temperature sensor.

## 7. CHECK INTERMITTENT INCIDENT

Perform [EC-119, "TROUBLE DIAGNOSIS FOR INTERMITTENT INCIDENT"](#) .

>> INSPECTION END.

### Component Inspection ENGINE COOLANT TEMPERATURE SENSOR

UBS00803

1. Check resistance between engine coolant temperature sensor terminals 1 and 2 as shown in the figure.

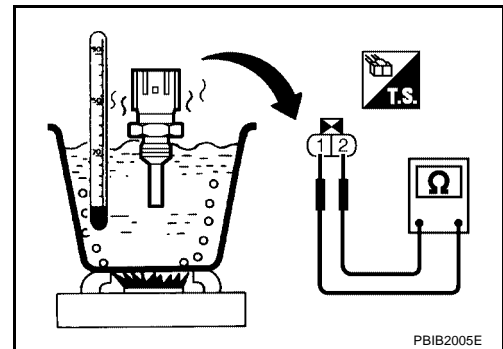

#### <Reference data>

Engine coolant temperature °C (°F)	Voltage V*	Resistance kΩ
20 (68)	3.5	2.1 - 2.9
50 (122)	2.2	0.68 - 1.00
90 (194)	0.9	0.236 - 0.260

\*: This data is reference value and is measured between ECM terminal 59 (Engine coolant temperature sensor) and ground.

2. If NG, replace engine coolant temperature sensor.

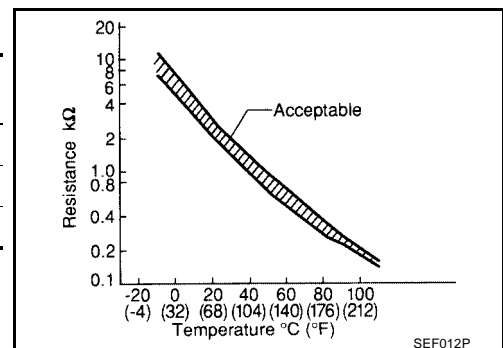

**Component Inspection**  
**HEATED OXYGEN SENSOR 1**

**With CONSULT-II**

1. Reconnect all harness connectors disconnected.
2. Start engine and warm it up to normal operating temperature.
3. Select "MANU TRIG" in "DATA MONITOR" mode, and the trigger point is adjusted to 100%.
4. Select "HO2S1 (B1)" and "HO2S1 MNTR (B1)" in item selection.
5. Hold engine speed at 2,000 rpm under no load during the following steps.
6. Touch "START" on CONSULT-II screen.

DATA MONITOR	
MONITOR	NO DTC
ENG SPEED	XXX rpm
MAS A/F SE-B1	XXX V
COOLAN TEMP/S	XXX °C
HO2S1 (B1)	XXX V
HO2S1 MNTR (B1)	LEAN

SEF646Y

7. Check the following.
  - "HO2S1 MNTR (B1)" in "DATA MONITOR" mode changes from "RICH" to "LEAN" to "RICH" more than 5 times in 10 seconds. 5 times (cycles) are counted as shown below:
  - "HO2S1 (B1)" voltage goes above 0.6V at least once.
  - "HO2S1 (B1)" voltage goes below 0.3V at least once.
  - "HO2S1 (B1)" voltage never exceeds 1.0V.

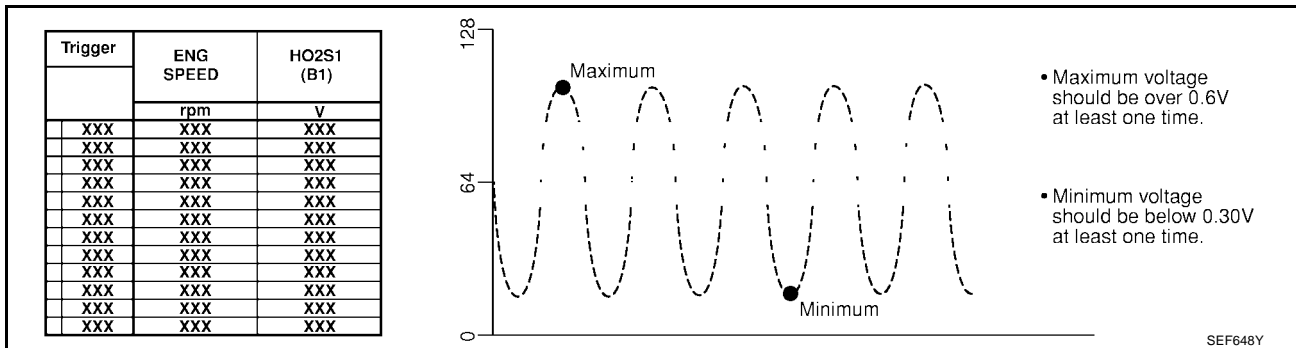
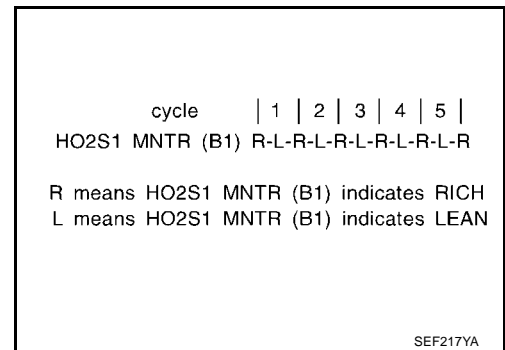

**CAUTION:**

- Discard any heated oxygen sensor which has been dropped from a height of more than 0.5 m (19.7 in) onto a hard surface such as a concrete floor; use a new one.
- Before installing new oxygen sensor, clean exhaust system threads using Oxygen Sensor Thread Cleaner tool J-43897-18 or J-43897-12 and approved anti-seize lubricant.

 **WITH GST**

1. Start engine and warm it up to normal operating temperature.
2. Turn ignition switch OFF and wait at least 5 seconds.
3. Disconnect mass air flow sensor harness connector. Then restart and run engine for at least 3 seconds at idle speed.
4. Stop engine and reconnect mass air flow sensor harness connector.
5. Select "MODE 3" with GST. Make sure DTC P0102 is detected.
6. Select "MODE 4" with GST and erase the DTC P0102.
7. Start engine again and run it for at least 10 minutes at idle speed.
8. Select "MODE 7" with GST. The 1st trip DTC P0171 should be detected at this stage, if a malfunction exists. If so, go to [EC-232, "Diagnostic Procedure"](#).
9. If it is difficult to start engine at step 8, the fuel injection system has a malfunction.
10. Crank engine while depressing accelerator pedal. If engine starts, go to [EC-232, "Diagnostic Procedure"](#). If engine does not start, visually check for exhaust and intake air leak.

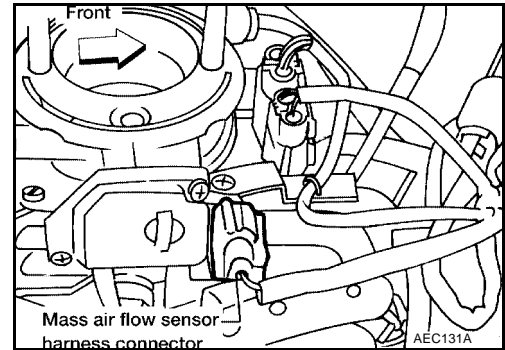

Specification data are reference values and are measured between each terminal and ground.

**CAUTION:**

**Do not use ECM ground terminals when measuring input/output voltage. Doing so may result in damage to the ECM's transistor. Use a ground other than ECM terminals, such as the ground.**

TER-MINAL NO.	WIRE COLOR	ITEM	CONDITION	DATA (DC Voltage)
64	W	Knock sensor	[Engine is running] ● Idle speed	Approximately 2.4V

**Diagnostic Procedure**

UBS008RF

**1. CHECK GROUND CONNECTIONS**

1. Turn ignition switch OFF.
2. Loosen and retighten ground screw.  
Refer to [EC-126, "Ground Inspection"](#) .

OK or NG

- OK >> GO TO 2.
- NG >> Repair or replace ground connections.

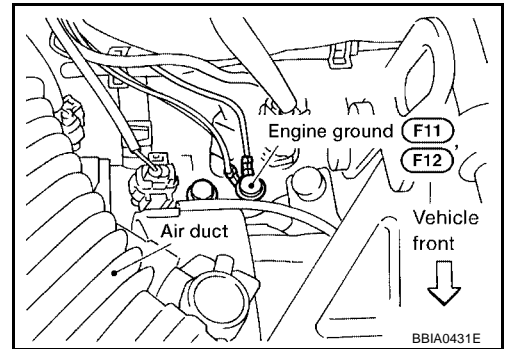

**2. CHECK INPUT SIGNAL CIRCUIT**

1. Turn ignition switch OFF.
2. Disconnect ECM harness connector.
3. Check harness continuity between ECM terminal 64 and ground.

**NOTE:**

It is necessary to use an ohmmeter which can measure more than 10 MΩ.

**Resistance : Approximately 500 - 620 kΩ [at 25°C (77°F)]**

4. Also check harness for short to ground and short to power.

OK or NG

- OK >> GO TO 4.
- NG >> GO TO 3.

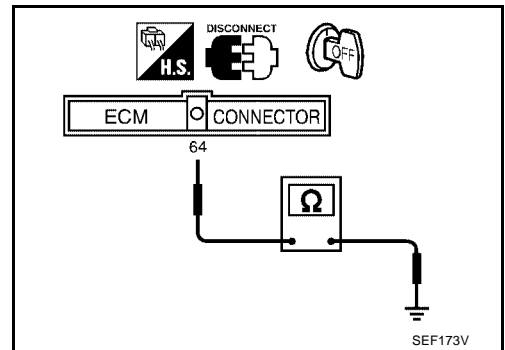

**3. DETECT MALFUNCTIONING PART**

Check the following.

- Harness connectors F2, F101
- Harness for open or short between knock sensor and ECM.

>> Repair open circuit or short to ground or short to power in harness or connectors.

**4. CHECK KNOCK SENSOR**

Refer to [EC-266, "Component Inspection"](#) .

OK or NG

- OK >> GO TO 5.
- NG >> Replace knock sensor.

# DTC P0405, P0406 EGRT SENSOR

[KA24DE]

UBS008SF

## Wiring Diagram

EC-EGR/TS-01

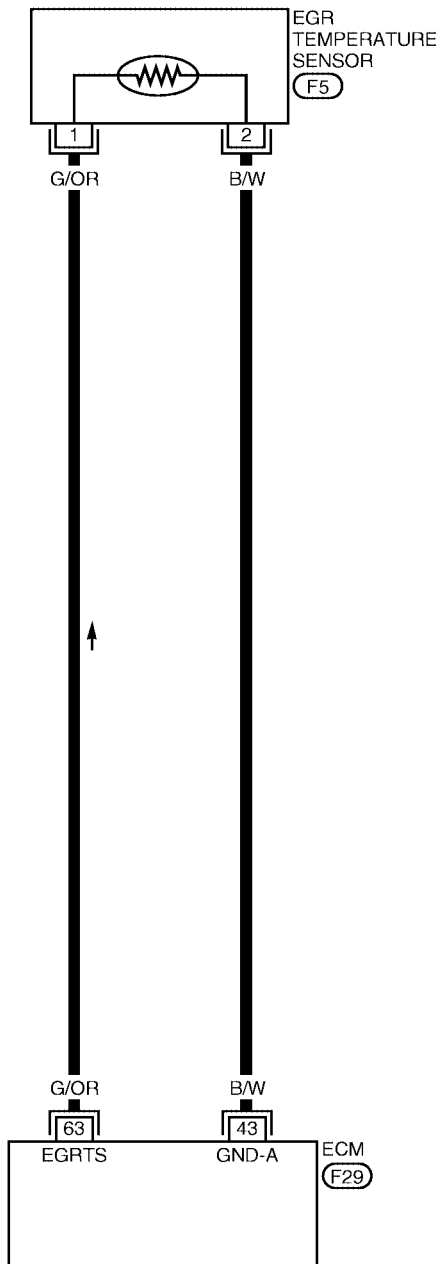

: Detectable line for DTC  
 : Non-detectable line for DTC

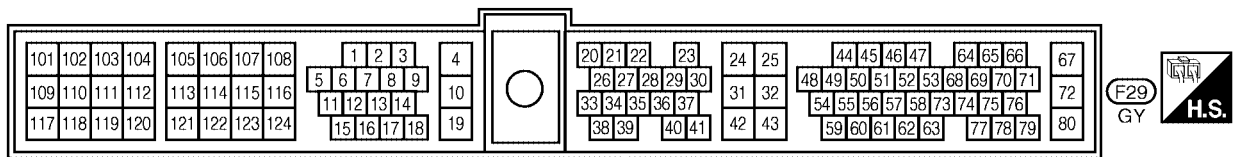
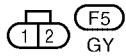

AEC006B

## Diagnostic Procedure

### 1. CHECK POWER SUPPLY

1. Turn ignition switch OFF.
2. Disconnect EVAP canister purge volume control solenoid valve harness connector.
3. Turn ignition switch ON.

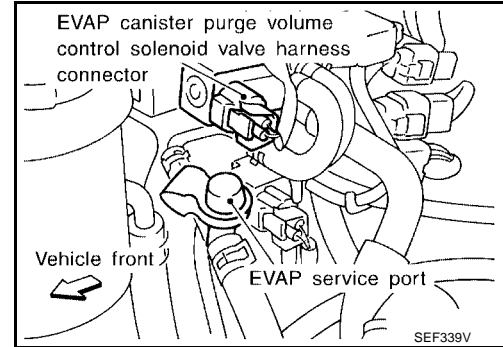

4. Check voltage between EVAP canister purge volume control solenoid valve terminal 2 and ground with CONSULT-II or tester.

**Voltage: Battery voltage**

OK or NG

- OK >> GO TO 3.  
 NG >> GO TO 2.

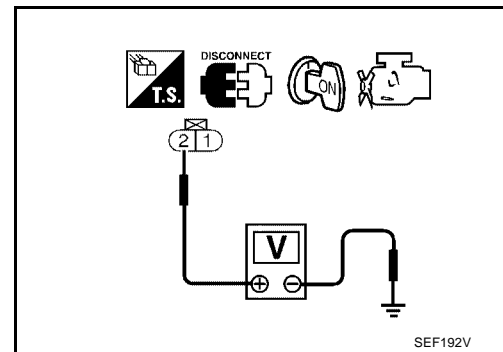

### 2. DETECT MALFUNCTIONING PART

Check the following.

- Harness for open or short between EVAP canister purge volume control solenoid valve and ECM relay
- Harness for open or short between EVAP canister purge volume control solenoid valve and ECM

>> Repair open circuit or short to ground or short to power in harness or connectors.

### 3. CHECK OUTPUT SIGNAL CIRCUIT

1. Turn ignition switch OFF.
2. Disconnect ECM harness connector.
3. Check harness continuity between ECM terminal 5 and EVAP canister purge volume control solenoid valve terminal 1.  
Refer to Wiring Diagram.

**Continuity should exist.**

4. Also, check harness for short to ground and short to power.

OK or NG

- OK (With CONSULT-II)>>GO TO 5.  
 OK (Without CONSULT-II)>>GO TO 6.  
 NG >> GO TO 4.

### 4. DETECT MALFUNCTIONING PART

Check the harness for open or short between EVAP canister purge volume control solenoid valve and ECM.

>> Repair open circuit or short to ground or short to power in harness or connectors.

## 20. CHECK REFUELING CONTROL VALVE

1. Remove fuel filler cap.
2. Check air continuity between hose ends A and B.  
Blow air into the hose end B. Air should flow freely into the fuel tank.
3. Blow air into hose end A and check there is no leakage.
4. Apply pressure to both hose ends A and B [20 kPa (150 mmHg, 5.91 inHg)] using a pressure pump and a suitable 3-way connector. Check that there is no leakage.

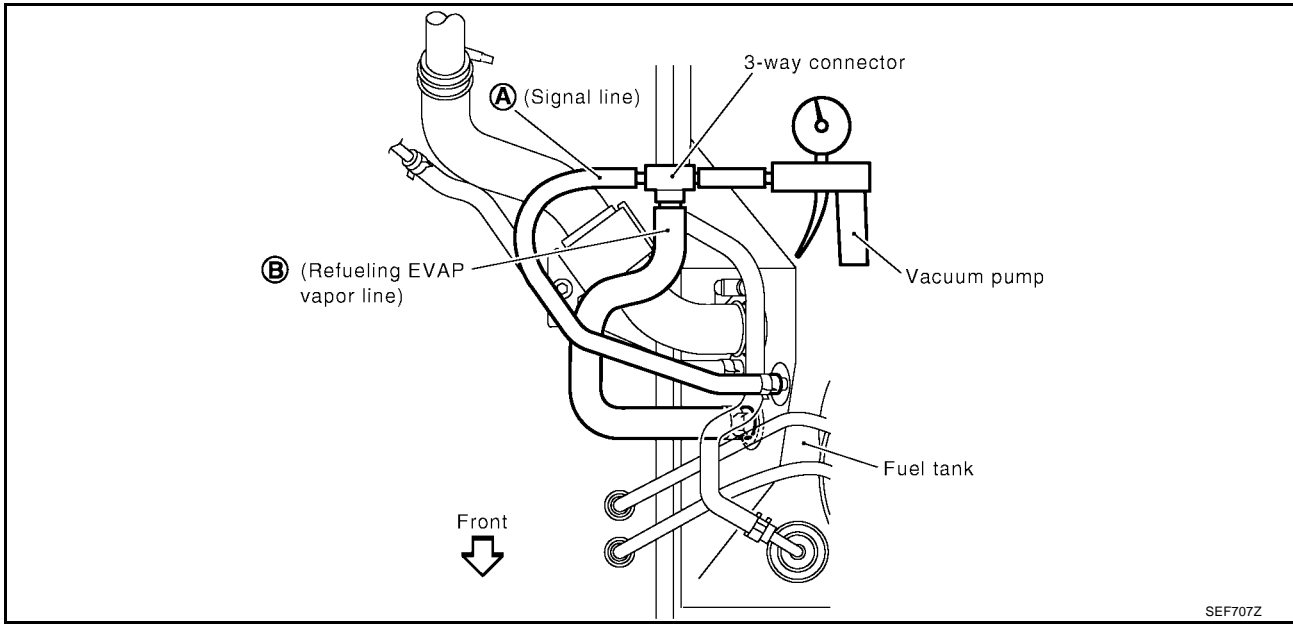

OK or NG

- OK >> GO TO 21.  
 NG >> Replace refueling control valve with fuel tank.

## 21. CHECK FUEL LEVEL SENSOR

1. Remove fuel level sensor assembly.  
Refer to [FL-6, "FUEL LEVEL SENSOR UNIT AND FUEL PUMP ASSEMBLY"](#).
2. Refer to [DI-17, "FUEL LEVEL SENSOR UNIT CHECK"](#).

OK or NG

- OK >> GO TO 22.  
 NG >> Replace fuel level sensor.

## 22. CHECK INTERMITTENT INCIDENT

Refer to [EC-119, "TROUBLE DIAGNOSIS FOR INTERMITTENT INCIDENT"](#).

>> INSPECTION END

Specification data are reference values and are measured between each terminal and ground.

**CAUTION:**

**Do not use ECM ground terminals when measuring input/output voltage. Doing so may result in damage to the ECM's transistor. Use a ground other than ECM terminals, such as the ground.**

TER-MINAL NO.	WIRE COLOR	ITEM	CONDITION	DATA (DC Voltage)
101	OR/L	IACV-AAC valve	<p><b>[Engine is running]</b></p> <ul style="list-style-type: none"> <li>● Warm-up condition</li> <li>● Idle speed</li> </ul> <p><b>NOTE:</b> The pulse cycle changes depending on rpm at idle.</p>	<p>10.5 - 11.5V★</p>
			<p><b>[Engine is running]</b></p> <ul style="list-style-type: none"> <li>● Warm-up condition</li> <li>● Engine speed is 2,000 rpm</li> </ul>	<p>1 - 13V★</p>

★: Average voltage for pulse signal (Actual pulse signal can be confirmed by oscilloscope.)

## Diagnostic Procedure

UBS008UP

### 1. CHECK POWER SUPPLY

1. Stop engine and turn ignition switch OFF.
2. Disconnect IACV-AAC valve harness connector.
3. Turn ignition switch ON.

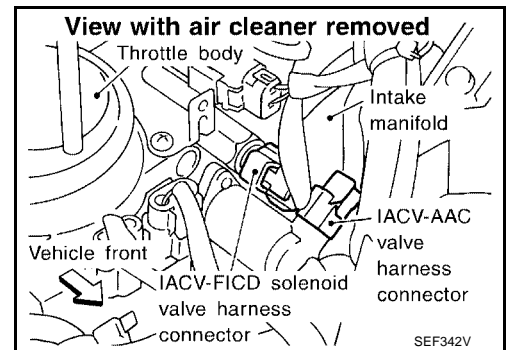

4. Check voltage between IACV-AAC valve terminal 2 and ground with CONSULT-II or tester.

**Voltage : Battery voltage**

OK or NG

- OK >> GO TO 3.
- NG >> GO TO 2.

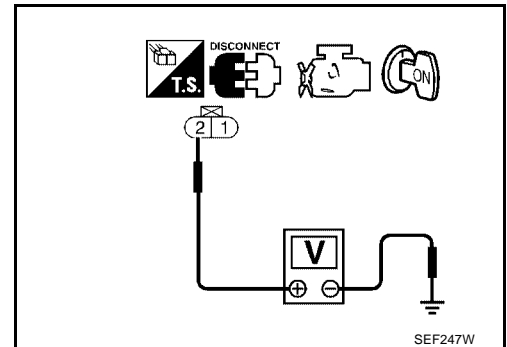

5. Set voltmeter probes between ECM terminals 56 (Heated oxygen sensor 2 signal) and ground.
6. Check the voltage when revving engine up to 4,000 rpm under no load at least 10 times.  
(Depress and release accelerator pedal as soon as possible.)  
**The voltage should be above 0.68V at least once during this procedure.**  
**If the voltage can be confirmed in step 4, step 5 is not necessary.**
7. Keep vehicle at idling for 10 minutes, then check the voltage. Or check the voltage when coasting from 80 km/h (50 MPH) in 3rd gear position.  
**The voltage should be above 0.68V at least once during this procedure.**
8. If NG, go to [EC-442, "Diagnostic Procedure"](#) .

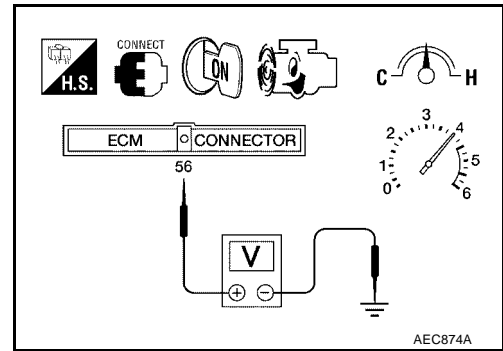

# DTC P1444 EVAP CANISTER PURGE VOLUME CONTROL SOLENOID VALVE [KA24DE]

UBS008X1

## Wiring Diagram

EC-PGC/V-01

— : Detectable line for DTC  
 - - - : Non-detectable line for DTC

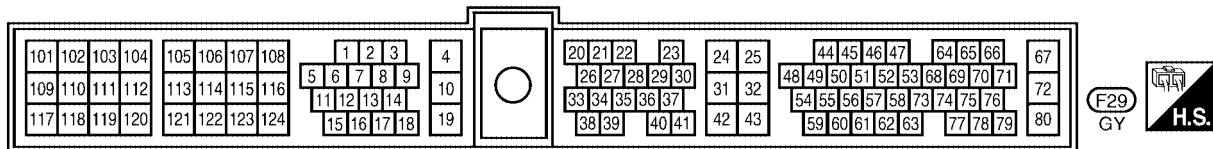
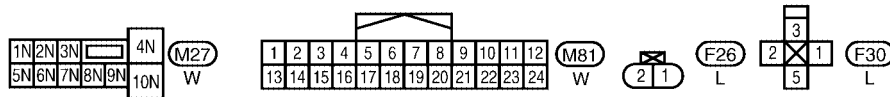
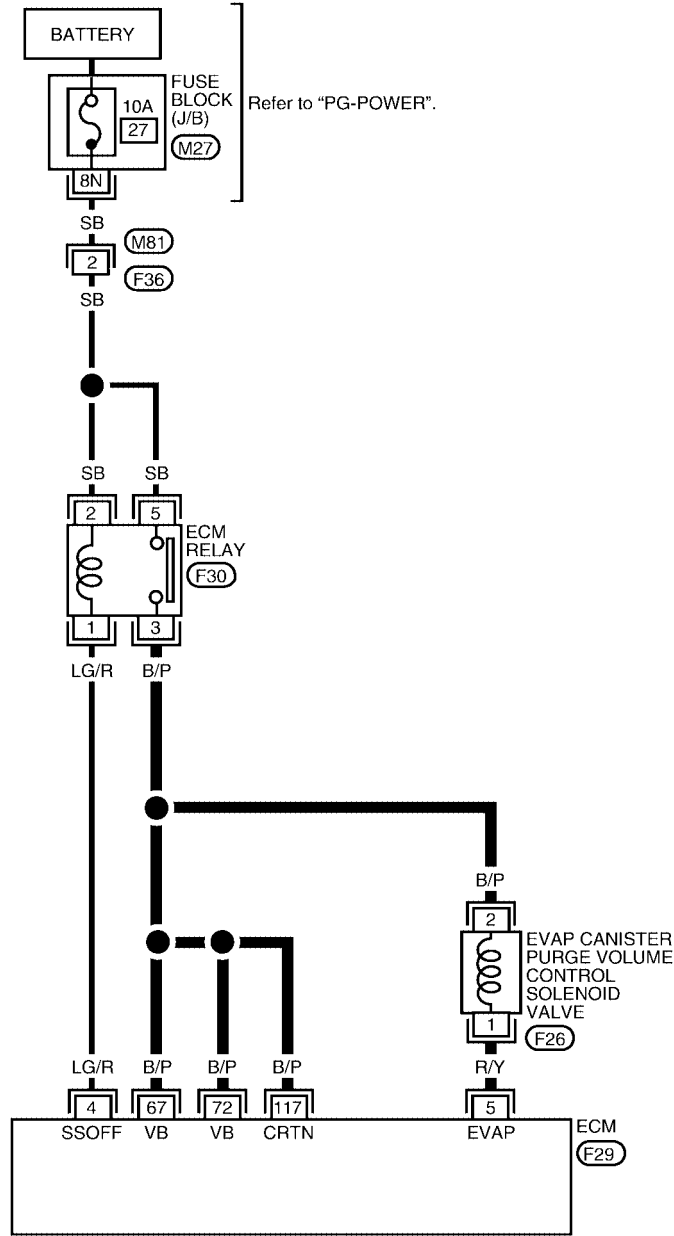

BBWA1061E

### 3. CHECK POWER SUPPLY

1. Turn ignition switch OFF.
2. Disconnect vacuum cut valve bypass valve harness connector.
3. Turn ignition switch ON.

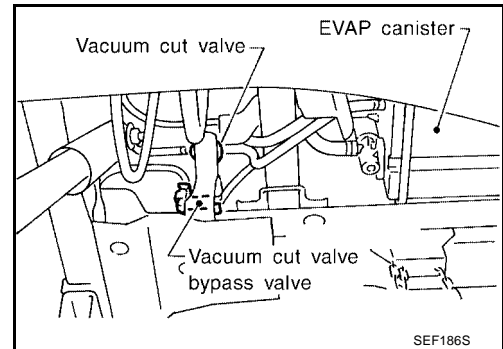

4. Check voltage between vacuum cut valve bypass valve terminal 2 and ground with CONSULT-II or tester.

**Voltage : Battery voltage**

OK or NG

- OK >> GO TO 5.
- NG >> GO TO 4.

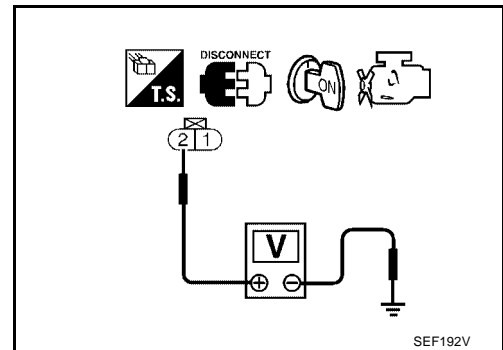

### 4. DETECT MALFUNCTIONING PART

Check the following.

- Harness connectors E43, M65
- Harness connectors M67, B101
- Harness connectors B112, C2
- Fuse block (J/B) connector E49
- 10A fuse
- Harness for open or short between vacuum cut valve bypass valve and fuse

>> Repair open circuit or short to ground or short to power in harness or connectors.

### 5. CHECK OUTPUT SIGNAL CIRCUIT

1. Turn ignition switch OFF.
2. Disconnect ECM harness connector.
3. Check harness continuity between ECM terminal 120 and vacuum cut valve bypass valve terminal 1. Refer to Wiring Diagram.

**Continuity should exist.**

4. Also check harness for short to ground and short to power.

OK or NG

- OK >> GO TO 7.
- NG >> GO TO 6.

# FUEL PUMP CIRCUIT

[KA24DE]

Specification data are reference values and are measured between each terminal and ground.

**CAUTION:**

Do not use ECM ground terminals when measuring input/output voltage. Doing so may result in damage to the ECM's transistor. Use a ground other than ECM terminals, such as the ground.

TER-MINAL NO.	WIRE COLOR	ITEM	CONDITION	DATA (DC Voltage)
11	W/R	Fuel pump relay	<b>[Ignition switch: ON]</b> ● For a few seconds after turning ignition switch ON <b>[Engine is running]</b>	0 - 1V
			<b>[Ignition switch: ON]</b> ● More than a few seconds after turning ignition switch ON	BATTERY VOLTAGE (11 - 14V)

## Diagnostic Procedure

UBS008Z3

### 1. CHECK OVERALL FUNCTION

- Turn ignition switch ON.
- Pinch fuel feed hose with two fingers.  
**Fuel pressure pulsation should be felt on the fuel feed hose for 5 seconds after ignition switch is turned ON.**

OK or NG

- OK >> **INSPECTION END**  
 NG >> GO TO 2.

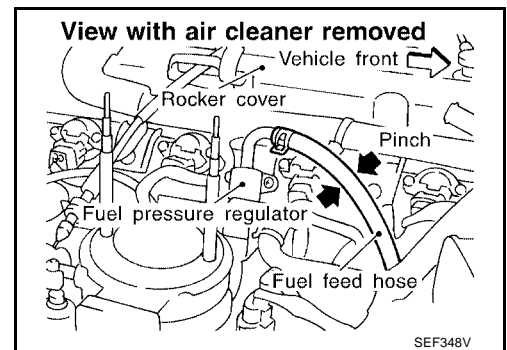

### 2. CHECK POWER SUPPLY

- Turn ignition switch OFF.
- Disconnect fuel pump relay.
- Turn ignition switch ON.

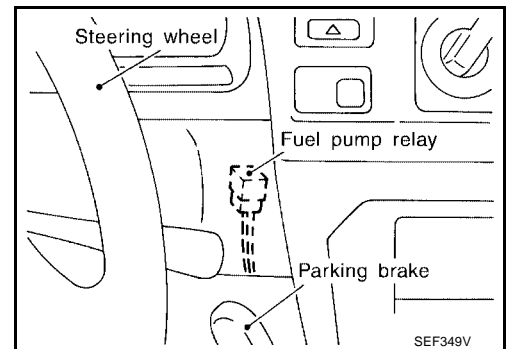

- Check voltage between terminals 2, 5 and ground with CONSULT-II or tester.

**Voltage : Battery voltage**

OK or NG

- OK >> GO TO 4.  
 NG >> GO TO 3.

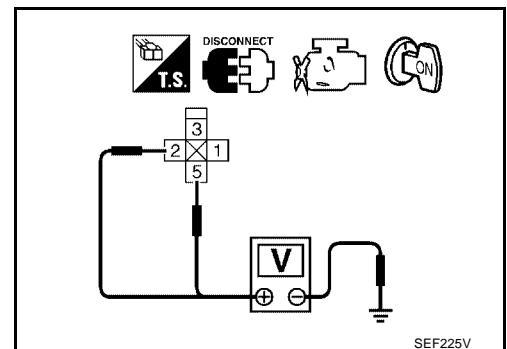

# INDEX FOR DTC

[VG33E]

Item (CONSULT-II screen terms)	DTC*1*2	Trip	MIL Lighting up	Reference page
	CONSULT-II GST			
IAT SENSOR	P0127	2	×	<a href="#">EC-761</a>
ISC SYSTEM/CIRC	P0505	2	×	<a href="#">EC-982</a>
KNOCK SEN/CIRC-B1	P0327	2	—	<a href="#">EC-855</a>
KNOCK SEN/CIRC-B1	P0328	2	—	<a href="#">EC-855</a>
L/PRESS SOL/CIRC	P0745	2	×	<a href="#">AT-156</a>
MAF SEN/CIRCUIT	P0101	2	×	<a href="#">EC-715</a>
MAF SEN/CIRCUIT	P0102	1	×	<a href="#">EC-723</a>
MAF SEN/CIRCUIT	P0103	2	×	<a href="#">EC-723</a>
MULTI CYL MISFIRE	P0300	2	×	<a href="#">EC-846</a>
<b>NO DTC IS DETECTED. FURTHER TESTING MAY BE REQUIRED.</b>	<b>P0000</b>	—	—	—
O/R CLTCH SOL/CIRC	P1760	2	×	<a href="#">AT-178</a>
P-N POS SW/CIRCUIT	P1706	2	×	<a href="#">EC-1124</a>
PNP SW/CIRC	P0705	2	×	<a href="#">AT-99</a>
PURG VOLUME CONT/V	P0444	2	×	<a href="#">EC-919</a>
PURG VOLUME CONT/V	P0445	2	×	<a href="#">EC-919</a>
PURG VOLUME CONT/V	P1444	2	×	<a href="#">EC-1064</a>
SFT SOL A/CIRC	P0750	2	×	<a href="#">AT-161</a>
SFT SOL B/CIRC	P0755	2	×	<a href="#">AT-166</a>
TCC SOLENOID/CIRC	P0740	2	×	<a href="#">AT-144</a>
THERMSTAT FNCTN	P0128	2	×	<a href="#">EC-764</a>
TP SEN/CIRC A/T	P1705	1	×	<a href="#">AT-171</a>
TP SEN/CIRCUIT	P0121	2	×	<a href="#">EC-741</a>
TP SEN/CIRCUIT	P0122	1	×	<a href="#">EC-750</a>
TP SEN/CIRCUIT	P0123	1	×	<a href="#">EC-750</a>
TW CATALYST SYS-B1	P0420	2	×	<a href="#">EC-893</a>
TW CATALYST SYS-B2	P0430	2	×	<a href="#">EC-893</a>
VC CUT/V BYPASS/V	P1491	2	×	<a href="#">EC-1106</a>
VC/V BYPASS/V	P1490	2	×	<a href="#">EC-1100</a>
VEH SPEED SEN/CIRC AT	P0720	2	×	<a href="#">AT-110</a>
VEH SPEED SEN/CIRC	P0500	2	×	<a href="#">EC-977</a>
VENT CONTROL VALVE	P0447	2	×	<a href="#">EC-926</a>
VENT CONTROL VALVE	P1446	2	×	<a href="#">EC-1073</a>
VENT CONTROL VALVE	P1448	2	×	<a href="#">EC-1079</a>

\*1: 1st trip DTC No. 1 is the same as DTC No.

\*2: This number is prescribed by SAE J2012.

\*3: This DTC is displayed with CONSULT-II only.

# ON BOARD DIAGNOSTIC (OBD) SYSTEM

[VG33E]

Items (CONSULT-II screen terms)	DTC*1*2	SRT code	Test value/ Test limit (GST only)	1st trip DTC*1	Reference page
	CONSULT-II GST				
FTT SEN/CIRCUIT	P0182	—	—	×	<a href="#">EC-837</a>
FTT SEN/CIRCUIT	P0183	—	—	×	<a href="#">EC-837</a>
ENG OVER TEMP	P0217	—	—	×	<a href="#">EC-841</a>
MULTI CYL MISFIRE	P0300	—	—	×	<a href="#">EC-846</a>
CYL1 MISFIRE	P0301	—	—	×	<a href="#">EC-846</a>
CYL2 MISFIRE	P0302	—	—	×	<a href="#">EC-846</a>
CYL3 MISFIRE	P0303	—	—	×	<a href="#">EC-846</a>
CYL4 MISFIRE	P0304	—	—	×	<a href="#">EC-846</a>
CYL5 MISFIRE	P0305	—	—	×	<a href="#">EC-846</a>
CYL6 MISFIRE	P0306	—	—	×	<a href="#">EC-846</a>
KNOCK SEN/CIRC-B1	P0327	—	—	×	<a href="#">EC-855</a>
KNOCK SEN/CIRC-B1	P0328	—	—	×	<a href="#">EC-855</a>
CKP SEN/CIRCUIT	P0335	—	—	×	<a href="#">EC-859</a>
CMP SEN/CIRCUIT	P0340	—	—	×	<a href="#">EC-865</a>
EGR SYSTEM	P0400	×	×	×*4	<a href="#">EC-872</a>
EGRC-BPT VALVE	P0402	×	×	×*4	<a href="#">EC-881</a>
EGR TEMP SEN/CIRC	P0405	—	—	×	<a href="#">EC-887</a>
EGR TEMP SEN/CIRC	P0406	—	—	×	<a href="#">EC-887</a>
TW CATALYST SYS-B1	P0420	×	×	×*4	<a href="#">EC-893</a>
TW CATALYST SYS-B2	P0430	×	×	×*4	<a href="#">EC-893</a>
EVAP PURG FLOW/MON	P0441	×	×	×*4	<a href="#">EC-899</a>
EVAP SMALL LEAK	P0442	×	×	×*4	<a href="#">EC-907</a>
PURG VOLUME CONT/V	P0444	—	—	×	<a href="#">EC-919</a>
PURG VOLUME CONT/V	P0445	—	—	×	<a href="#">EC-919</a>
VENT CONTROL VALVE	P0447	—	—	×	<a href="#">EC-926</a>
EVAP SYS PRES SEN	P0452	—	—	×	<a href="#">EC-932</a>
EVAP SYS PRES SEN	P0453	—	—	×	<a href="#">EC-938</a>
EVAP GROSS LEAK	P0455	—	×	×	<a href="#">EC-947</a>
EVAP VERY SML LEAK	P0456	×*3	×	×*4	<a href="#">EC-956</a>
FUEL LEV SEN SLOSH	P0460	—	—	×	<a href="#">EC-967</a>
FUEL LEVEL SENSOR	P0461	—	—	×	<a href="#">EC-971</a>
FUEL LEVL SEN/CIRC	P0462	—	—	×	<a href="#">EC-973</a>
FUEL LEVL SEN/CIRC	P0463	—	—	×	<a href="#">EC-973</a>
VEH SPEED SEN/CIRC	P0500	—	—	×	<a href="#">EC-977</a>
ISC SYSTEM/CIRC	P0505	—	—	×	<a href="#">EC-982</a>
CLOSED TP SW/CIRC	P0510	—	—	×	<a href="#">EC-989</a>
A/T COMM LINE	P0600	—	—	×	<a href="#">EC-996</a>
ECM	P0605	—	—	×	<a href="#">EC-1002</a>
PNP SW/CIRC	P0705	—	—	×	<a href="#">AT-99</a>
ATF TEMP SEN/CIRC	P0710	—	—	×	<a href="#">AT-105</a>
VEH SPD SEN/CIR AT	P0720	—	—	×	<a href="#">AT-110</a>
ENGINE SPEED SIG	P0725	—	—	×	<a href="#">AT-115</a>

A  
EC  
C  
D  
E  
F  
G  
H  
I  
J  
K  
L  
M

**20. ADJUSTMENT THROTTLE POSITION SWITCH IDLE POSITION**

⊗ Without CONSULT-II

**NOTE:**

- Never adjust throttle adjust screw (TAS).
  - Do not touch throttle drum when checking continuity, doing so may cause an incorrect adjustment.
1. Warm up engine to normal operating temperature.
  2. Check FI cam. Refer to procedure 14 or 15.
  3. Stop engine.
  4. Loosen throttle position sensor fixing bolts.

>> GO TO 21.

**21. ADJUSTMENT CLOSED THROTTLE POSITION SWITCH IDLE POSITION-II**

1. Disconnect closed throttle position switch harness connector.
2. Insert 0.35 mm (0.0138 in) feeler gauge between the throttle adjust screw and throttle drum as shown in the figure.
3. Open throttle valve then close.

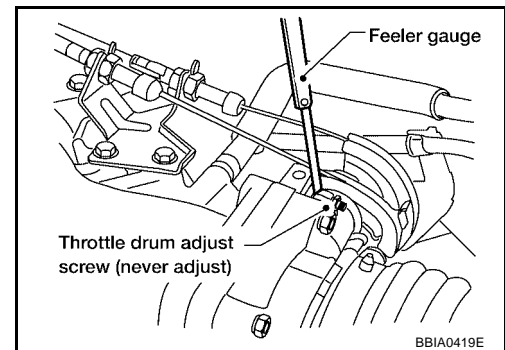

4. Check continuity between closed throttle position switch terminals 5 and 6.

**Continuity should not exist while closing the throttle position sensor.**

OK or NG

- OK >> GO TO 23.
- NG >> GO TO 22.

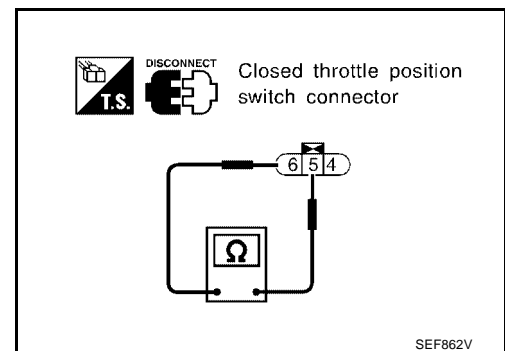

**22. ADJUSTMENT THROTTLE POSITION SWITCH IDLE POSITION-III**

⊗ Without CONSULT-II

Turn throttle position sensor body counterclockwise until continuity does not exist.

>> GO TO 23.

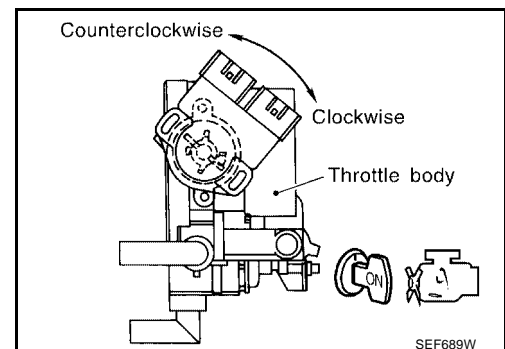

# TROUBLE DIAGNOSIS

[VG33E]

Each value is for reference, the exact value may vary.

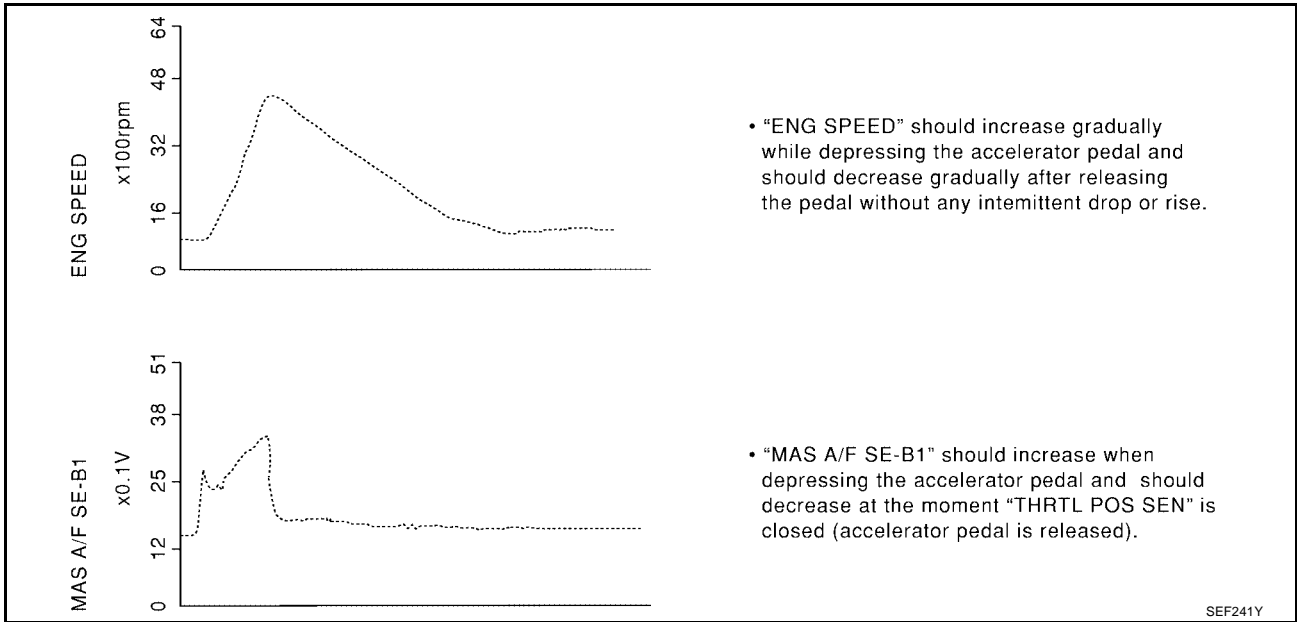

A

EC

C

D

E

F

G

H

I

J

K

L

M

## 3. CHECK GROUND CONNECTIONS

1. Turn ignition switch OFF.
2. Loosen and retighten ground screw.  
Refer to [EC-697, "Ground Inspection"](#).

OK or NG

- OK >> GO TO 4.  
NG >> Repair or replace ground connections.

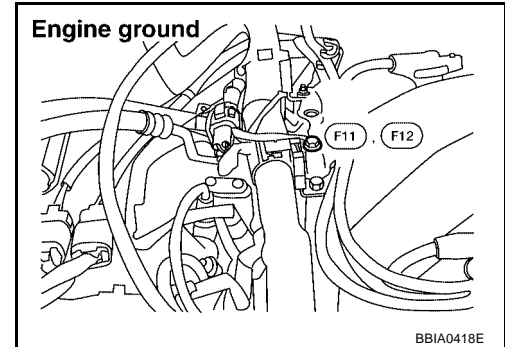

## 4. CHECK MAF SENSOR POWER SUPPLY CIRCUIT

1. Disconnect mass air flow (MAF) sensor harness connector.
2. Turn ignition switch ON.

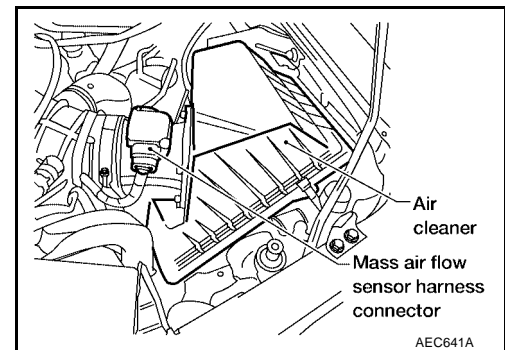

3. Check voltage between MAF sensor terminal 2 and ground with CONSULT-II or tester.

**Voltage: Battery voltage**

OK or NG

- OK >> GO TO 6.  
NG >> GO TO 5.

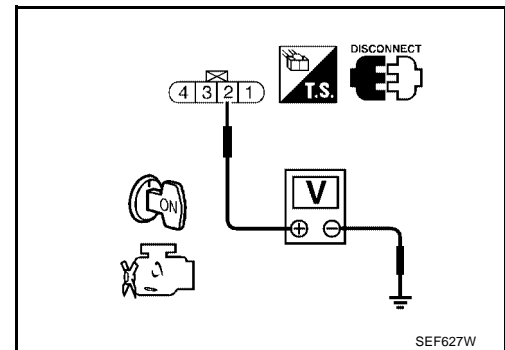

## 5. DETECT MALFUNCTIONING PART

Check the following.

- Harness for open or short between ECM relay and mass air flow sensor
- Harness for open or short between mass air flow sensor and ECM

>> Repair harness or connectors.

**6. ADJUST CLOSED THROTTLE POSITION SWITCH**

Adjust closed throttle position switch. Refer to [EC-640, "Basic Inspection"](#) .

Items	Specifications
Ignitions timing	M/T: 10 ± 5° BTDC (in Neutral position) A/T: 10 ± 5° BTDC (in P or N position)
Base idle speed	M/T: 700 ± 50 rpm (in Neutral position) A/T: 700 ± 50 rpm (in P or N position)
Closed throttle position switch idle position adjustment	Feeler gauge thickness and switch condition 0.3 mm (0.012 in): ON 0.4 mm (0.016 in): OFF
Target idle speed	M/T: 750 ± 50 rpm (in Neutral position) A/T: 750 ± 50 rpm (in P or N position)

**OK or NG**

OK >> GO TO 7.

NG >> Replace throttle position sensor. To adjust it, perform [EC-640, "Basic Inspection"](#) .

**7. CHECK MASS AIR FLOW SENSOR**

Refer to [EC-721, "Component Inspection"](#) .

**OK or NG**

OK >> GO TO 8.

NG >> Replace mass air flow sensor.

A  
EC  
C  
D  
E  
F  
G  
H  
I  
J  
K  
L  
M

Wiring Diagram  
BANK 1

EC-O2S1B1-01

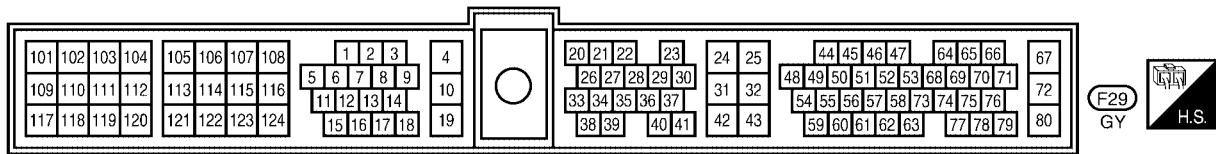
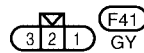
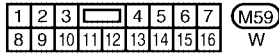
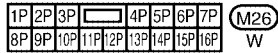
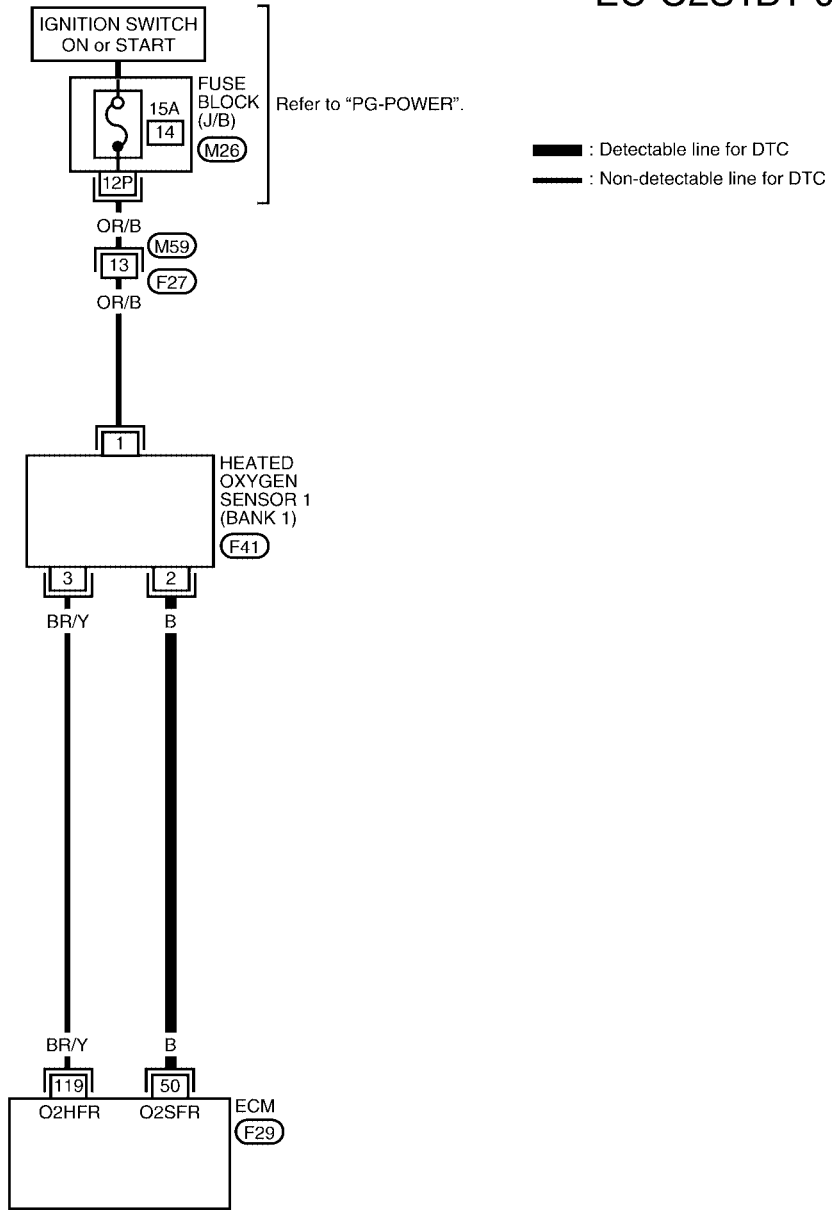

## DTC P0172, P0175 FUEL INJECTION SYSTEM FUNCTION

PFP:16600

### On Board Diagnosis Logic

UBS00725

With the Air-Fuel Mixture Ratio Self-Learning Control, the actual mixture ratio can be brought closely to the theoretical mixture ratio based on the mixture ratio feedback signal from the heated oxygen sensor 1. The ECM calculates the necessary compensation to correct the offset between the actual and the theoretical ratios.

In case the amount of the compensation value is extremely large (The actual mixture ratio is too rich.), the ECM judges the condition as the fuel injection system malfunction and lights up the MIL (2 trip detection logic).

Sensor	Input signal to ECM	ECM function	Actuator
Heated oxygen sensor 1	Density of oxygen in exhaust gas (Mixture ratio feedback signal)	Fuel injection control	Fuel injector

DTC No.	Trouble diagnosis name	DTC detecting condition	Possible cause
P0172 (Bank 1)	Fuel injection system too rich	<ul style="list-style-type: none"> <li>● Fuel injection system does not operate properly.</li> <li>● The amount of mixture ratio compensation is too large. (The mixture ratio is too rich.)</li> </ul>	<ul style="list-style-type: none"> <li>● Heated oxygen sensor 1</li> <li>● Fuel injector</li> <li>● Exhaust gas leaks</li> <li>● Incorrect fuel pressure</li> <li>● Mass air flow sensor</li> </ul>
P0175 (Bank 2)			

### DTC Confirmation Procedure

UBS00726

**NOTE:**

If DTC Confirmation Procedure has been previously conducted, always turn ignition switch OFF and wait at least 5 seconds before conducting the next test.

**ⓑ WITH CONSULT-II**

1. Start engine and warm it up to normal operating temperature.
2. Turn ignition switch OFF and wait at least 5 seconds.
3. Turn ignition switch ON and select "SELF-LEARNING CONT" in "WORK SUPPORT" mode with CONSULT-II.
4. Clear the self-learning control coefficient by touching "CLEAR".
5. Select "DATA MONITOR" mode with CONSULT-II.
6. Start engine again and let it idle for at least 10 minutes. The 1st trip DTC P0172, P0175 should be detected at this stage, if a malfunction exists. If so, go to [EC-829, "Diagnostic Procedure"](#).
7. If it is difficult to start engine at step 6, the fuel injection system has a malfunction, too.
8. Crank engine while depressing accelerator pedal. If engine starts, go to [EC-829, "Diagnostic Procedure"](#). If engine does not start, remove ignition plugs and check for fouling, etc.

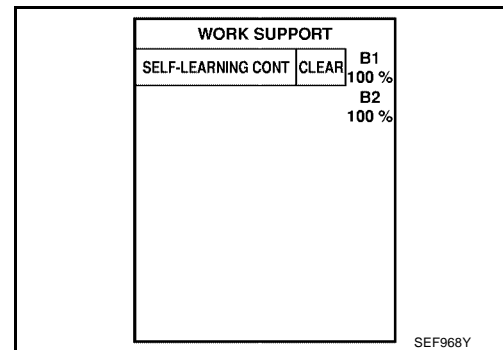

**Ⓒ WITH GST**

1. Start engine and warm it up to normal operating temperature.
2. Turn ignition switch OFF and wait at least 5 seconds.

---

 **WITH GST**

Follow the procedure "WITH CONSULT-II" above.

## DTC P0420, P0430 THREE WAY CATALYST FUNCTION

[VG33E]

7. Make sure that the voltage switching frequency (high & low) between ECM terminals 56 and ground, or 57 and ground is very less than that of ECM terminals 50 and ground, or 51 and ground.

**Switching frequency ratio = A/B**

**A: Heated oxygen sensor 2 voltage switching frequency**

**B: Heated oxygen sensor 1 voltage switching frequency**

**This ratio should be less than 0.75.**

If the ratio is greater than above, it means three way catalyst (manifold) does not operate properly. Go to [EC-896, "Diagnostic Procedure"](#).

### NOTE:

If the voltage at terminal 50 or 51 does not switch periodically more than 5 times within 10 seconds at step 5, perform trouble diagnosis for DTC P0133, P0153 first. (See [EC-775, "DTC P0133, P0153 HO2S1"](#).)

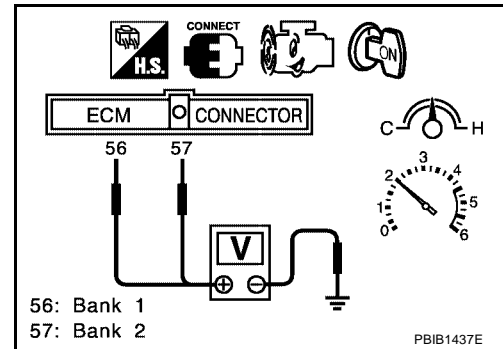

A

EC

C

D

E

F

G

H

I

J

K

L

M

## 3. CHECK EVAP CANISTER VENT CONTROL VALVE POWER SUPPLY CIRCUIT

1. Turn ignition switch OFF.
2. Disconnect EVAP canister vent control valve harness connector.
3. Turn ignition switch ON.

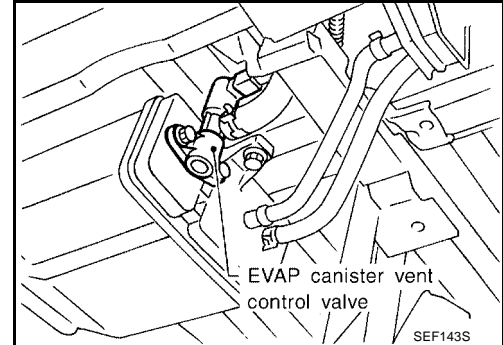

4. Check voltage between EVAP canister vent control valve terminal 1 and ground with CONSULT-II or tester.

**Voltage : Battery voltage**

OK or NG

- OK >> GO TO 5.  
 NG >> GO TO 4.

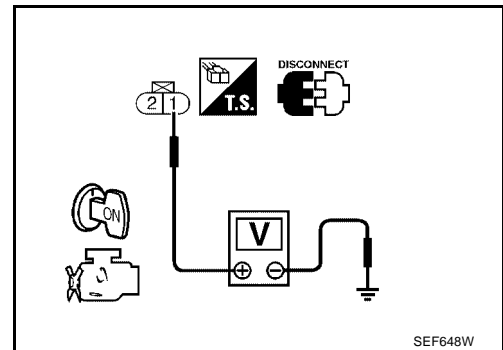

## 4. DETECT MALFUNCTIONING PART

Check the following.

- Harness connectors E43, M65
- Harness connectors M67, B101
- Harness connectors B112, C2
- Fuse block (J/B) connector E49
- 10A fuse
- Harness for open or short between EVAP canister vent control valve and fuse

>> Repair harness or connectors.

## 5. CHECK EVAP CANISTER VENT CONTROL VALVE OUTPUT SIGNAL CIRCUIT FOR OPEN AND SHORT

1. Turn ignition switch OFF.
2. Disconnect ECM harness connector.
3. Check harness continuity between ECM terminal 108 and EVAP canister vent control valve terminal 2. Refer to Wiring Diagram.

**Continuity should exist.**

4. Also check harness for short to ground and short to power.

OK or NG

- OK >> GO TO 7.  
 NG >> GO TO 6.

**18. CHECK FUEL TANK TEMPERATURE SENSOR**

1. Remove fuel level sensor unit.
2. Check resistance between fuel level sensor unit terminals 1 and 4 by heating with hot water or heat gun as shown in the figure.

Temperature °C (°F)	Resistance kΩ
20 (68)	2.3 - 2.7
50 (122)	0.79 - 0.90

OK or NG

- OK >> GO TO 19.
- NG >> Replace fuel level sensor unit.

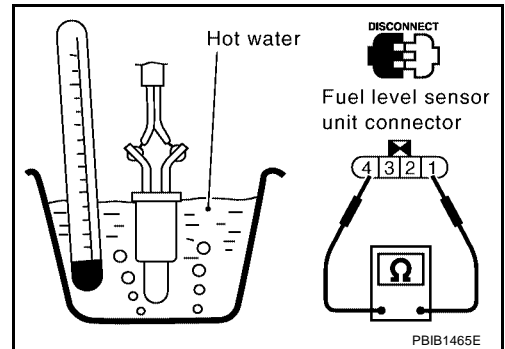

**19. CHECK EVAP CONTROL SYSTEM PRESSURE SENSOR**

1. Remove EVAP control system pressure sensor with its harness connector connected.
2. Remove hose from EVAP control system pressure sensor.
3. Turn ignition switch ON.
4. Use pump to apply vacuum and pressure to EVAP control system pressure sensor as shown in figure.
5. Check input voltage between ECM terminal 62 and ground.

Applied vacuum	Voltage V
Not applied	1.8 - 4.8
-26.7 kpa (-200 mmHg, -7.87 inHg)	2.1 to 2.5V lower than above value

**CAUTION:**

- Always calibrate the vacuum pump gauge when using it.
- Do not apply below -93.3 kPa (-700 mmHg, -27.56 inHg) or over 101.3 kPa (760 mmHg, 29.92 inHg) of pressure.

OK or NG

- OK >> GO TO 20.
- NG >> Replace EVAP control system pressure sensor.

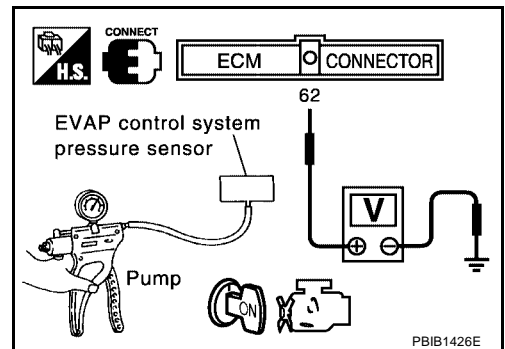

**20. CHECK EVAP PURGE LINE**

Check EVAP purge line (pipe, rubber tube, fuel tank and EVAP canister) for cracks or improper connection. Refer to [EC-1163, "EVAPORATIVE EMISSION LINE DRAWING"](#).

OK or NG

- OK >> GO TO 21.
- NG >> Repair or reconnect the hose.

**21. CLEAN EVAP PURGE LINE**

Clean EVAP purge line (pipe and rubber tube) using air blower.

>> GO TO 22.

**22. CHECK REFUELING EVAP VAPOR LINE**

Check refueling EVAP vapor line between EVAP canister and fuel tank for clogging, kink, looseness and improper connection. For location, refer to [EC-1168, "ON BOARD REFUELING VAPOR RECOVERY \(ORVR\)"](#).

OK or NG

- OK >> GO TO 23.
- NG >> Repair or replace hoses and tubes.

CLICK HERE TO **DOWNLOAD** THE COMPLETE MANUAL

- Thank you very much for reading the preview of the manual.
- You can download the complete manual from: [www.heydownloads.com](http://www.heydownloads.com) by clicking the link below



- Please note: If there is no response to CLICKING the link, please download this PDF first and then click on it.

CLICK HERE TO **DOWNLOAD** THE COMPLETE MANUAL

TER-MINAL NO.	WIRE COLOR	ITEM	CONDITION	DATA (DC Voltage)
68	W/G	A/T signal	<b>[Engine is running]</b> ● Idle speed	Approximately 0 - 5.0V

## Diagnostic Procedure

UBS00CVZ

### WITHOUT VDC

#### 1. CHECK A/T CONTROL INPUT SIGNAL CIRCUIT FOR OPEN

1. Turn ignition switch OFF.
2. Disconnect ECM harness connector and TCM (Transmission Control Module) harness connector.

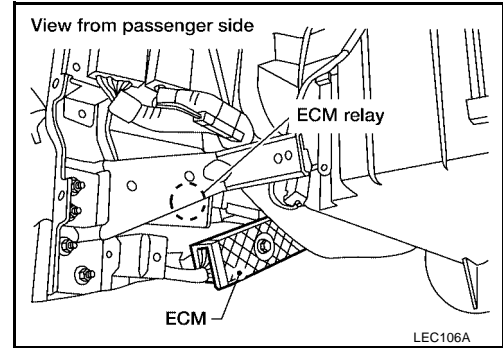

3. Check harness continuity between ECM terminal 26 and TCM terminal 5, ECM terminal 27 and TCM terminal 6, ECM terminal 35 and TCM terminal 7. Refer to Wiring Diagram.

**Continuity should exist.**

OK or NG

- OK >> GO TO 3.
- NG >> GO TO 2.

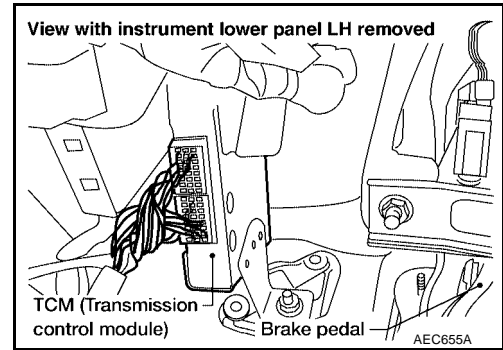

#### 2. DETECT MALFUNCTIONING PART

Check the following.

- Harness connectors M58, F28
- Harness for open or short between ECM and TCM (Transmission Control Module)

>> Repair open circuit or short to ground or short to power in harness or connectors.

#### 3. CHECK A/T CONTROL INPUT SIGNAL CIRCUIT FOR SHORT

1. Check harness continuity between ECM terminal 26 and ground, ECM terminal 27 and ground, ECM terminal 35 and ground. Refer to Wiring Diagram.

**Continuity should not exist.**

2. Also check harness for short to power.

OK or NG

- OK >> GO TO 5.
- NG >> GO TO 4.

5. CHECK HEATED OXYGEN SENSOR 2

 With CONSULT-II

1. Turn ignition switch ON and select "DATA MONITOR" mode with CONSULT-II.
2. Start engine and warm it up to the normal operating temperature.
3. Turn ignition switch OFF and wait at least 10 seconds.
4. Start engine and keep the engine speed between 3,500 and 4,000 rpm for at least 1 minute under no load.
5. Let engine idle for 1 minute.
6. Select "FUEL INJECTION" in "ACTIVE TEST" mode, and select "HO2S2 (B1)/(B2)" as the monitor item with CONSULT-II.

ACTIVE TEST	
FUEL INJECTION	25 %
MONITOR	
ENG SPEED	XXX rpm
HO2S1 (B1)	XXX V
HO2S2 (B1)	XXX V
HO2S1 MNTR (B1)	RICH
HO2S2 MNTR (B1)	RICH

SEF662Y

7. Check "HO2S2 (B1)/(B2)" at idle speed when adjusting "FUEL INJECTION" to  $\pm 25\%$ .

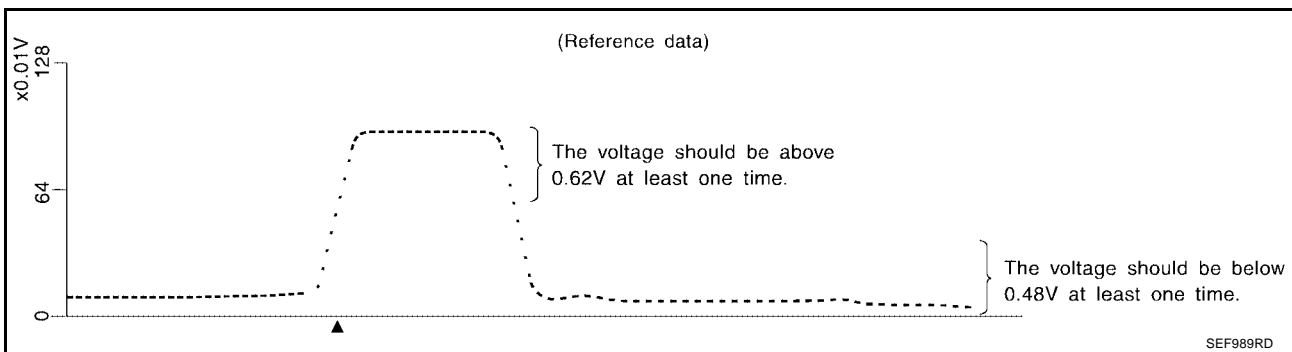

"HO2S2 (B1)/(B2)" should be above 0.62V at least once when the "FUEL INJECTION" is +25%.  
 "HO2S2 (B1)/(B2)" should be below 0.48V at least once when the "FUEL INJECTION" is -25%.

**CAUTION:**

- Discard any heated oxygen sensor which has been dropped from a height of more than 0.5 m (19.7 in) onto a hard surface such as a concrete floor; use a new one.
- Before installing new oxygen sensor, clean exhaust system threads using Oxygen Sensor Thread Cleaner tool J-43897-18 or J-43897-12 and approved anti-seize lubricant.

OK or NG

- OK >> GO TO 7.  
 NG >> Replace malfunctioning heated oxygen sensor 2.

# DTC P1444 EVAP CANISTER PURGE VOLUME CONTROL SOLENOID VALVE

[VG33E]

## 8. CHECK EVAP CANISTER PURGE VOLUME CONTROL SOLENOID VALVE

 **With CONSULT-II**

1. Start engine.
2. Perform "PURG VOL CONT/V" in "ACTIVE TEST" mode with CONSULT-II. Check that engine speed varies according to the valve opening.  
If OK, inspection end. If NG, go to following step.

ACTIVE TEST	
PURG VOL CONT/V	0.0%
MONITOR	
ENG SPEED	XXX rpm
A/F ALPHA-B1	XXX %
A/F ALPHA-B2	XXX %
HO2S1 MNTR (B1)	RICH
HO2S1 MNTR (B2)	RICH
THRTL POS SEN	XXX V

SEF985Y

3. Check air passage continuity.

Condition PURG VOL CONT/V value	Air passage continuity between A and B
100%	Yes
0%	No

If NG, replace the EVAP canister purge volume control solenoid valve.

OK or NG

- OK >> GO TO 10.
- NG >> Replace EVAP canister purge volume control solenoid valve.

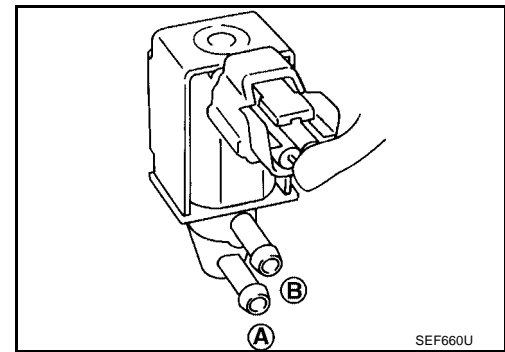

## 9. CHECK EVAP CANISTER PURGE VOLUME CONTROL SOLENOID VALVE

 **Without CONSULT-II**

Check air passage continuity.

Condition	Air passage continuity between A and B
12V direct current supply between terminals 1 and 2	Yes
No supply	No

If NG, replace the EVAP canister purge volume control solenoid valve.

OK or NG

- OK >> GO TO 10.
- NG >> Replace EVAP canister purge volume control solenoid valve.

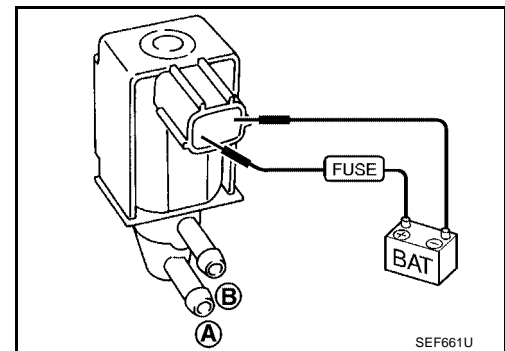

## 6. DETECT MALFUNCTIONING PART

Check the following.

- Harness connectors C3, B113
- Harness connectors B101, M67
- Harness connectors M81, F36
- Harness for open or short between vacuum cut valve bypass valve and ECM

>> Repair open circuit or short to ground or short to power in harness or connectors.

## 7. CHECK VACUUM CUT VALVE BYPASS VALVE

### With CONSULT-II

1. Perform "VC/V BYPASS/V" in "ACTIVE TEST" mode.

ACTIVE TEST	
VC/V BYPASS/V	OFF
MONITOR	
ENG SPEED	XXX rpm
A/F ALPHA-B1	XXX %
A/F ALPHA-B2	XXX %
HO2S1 MNTR (B1)	LEAN
HO2S1 MNTR (B2)	LEAN
THRTL POS SEN	XXX V

SEF014Z

2. Check air passage continuity and operation delay time under the following conditions.

Condition VC/V BYPASS/V	Air passage continuity between A and B
ON	Yes
OFF	No

**Operation takes less than 1 second.**

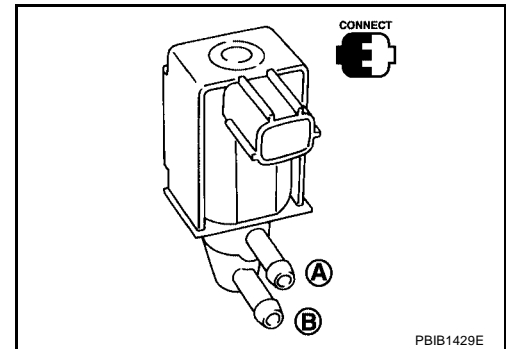

### Without CONSULT-II

Check air passage continuity and operation delay time under the following conditions.

Condition	Air passage continuity between A and B
12V direct current supply between terminals 1 and 2	Yes
No supply	No

**Operation takes less than 1 second.**

OK or NG

- OK >> GO TO 8.
- NG >> Replace vacuum cut valve bypass valve.

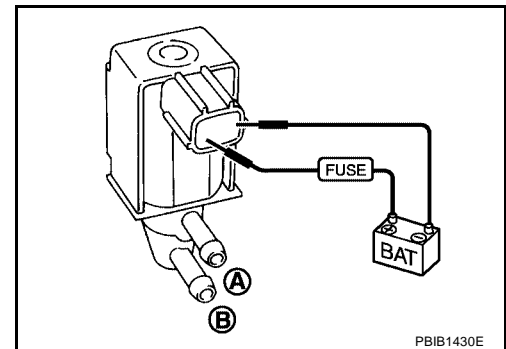

## 8. CHECK INTERMITTENT INCIDENT

Refer to [EC-691, "TROUBLE DIAGNOSIS FOR INTERMITTENT INCIDENT"](#) .

>> INSPECTION END.

## 2. CHECK OVERALL FUNCTION

 **With CONSULT-II**

1. Start engine.
2. Perform "POWER BALANCE" in "ACTIVE TEST" mode with CONSULT-II.
3. Make sure that each circuit produces a momentary engine speed drop.

ACTIVE TEST	
POWER BALANCE	
MONITOR	
ENG SPEED	XXX rpm
MAS AIF SE-B1	XXX V
IACV-AAC/V	XXX step

SEF070Y

 **Without CONSULT-II**

1. Start engine.
2. Listen to each injector operating sound.  
**Clicking noise should be heard.**

OK or NG

- OK    >> **INSPECTION END.**  
 NG    >> **GO TO 3.**

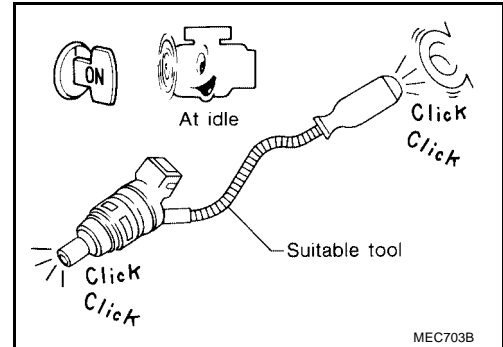

## 3. CHECK INJECTOR POWER SUPPLY CIRCUIT

1. Turn ignition switch OFF.
2. Disconnect injector harness connector.
3. Turn ignition switch ON.
4. Check voltage between injector terminal 1 and ground with CONSULT-II or tester.

**Voltage: Battery voltage**

OK or NG

- OK    >> **GO TO 5.**  
 NG    >> **GO TO 4.**

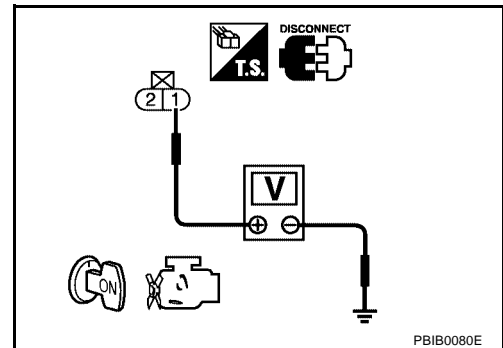

## 9. CHECK REFUELING EVAP VAPOR CUT VALVE

**With CONSULT-II**

1. Remove fuel tank. Refer to [FL-3, "FUEL TANK"](#) .
2. Drain fuel from the tank as follows:
  - Remove fuel feed hose located on the fuel level sensor unit retainer.
  - Connect a spare fuel hose, one side to fuel level sensor unit retainer where the hose was removed and the other side to a fuel container.
  - Drain fuel using "FUEL PUMP RELAY" in "ACTIVE TEST" mode with CONSULT-II.
3. Check refueling EVAP vapor cut valve for being stuck to close as follows.
 

Blow air into the refueling EVAP vapor cut valve (from hose end B), and check that the air flows freely into the tank.
4. Check EVAP vapor cut valve for being stuck to open as follows.
  - Connect vacuum pump to hose ends A and B using a suitable 3-way connector.
  - Remove fuel level sensor unit retainer with fuel level sensor unit.
  - Always replace O-ring with new one.**
  - Put fuel tank upside down.
  - Apply vacuum pressure to both hose ends A and B [-13.3 kPa (-100 mmHg, -3.94 inHg)] with fuel level sensor unit retainer remaining open and check that the pressure is applicable.

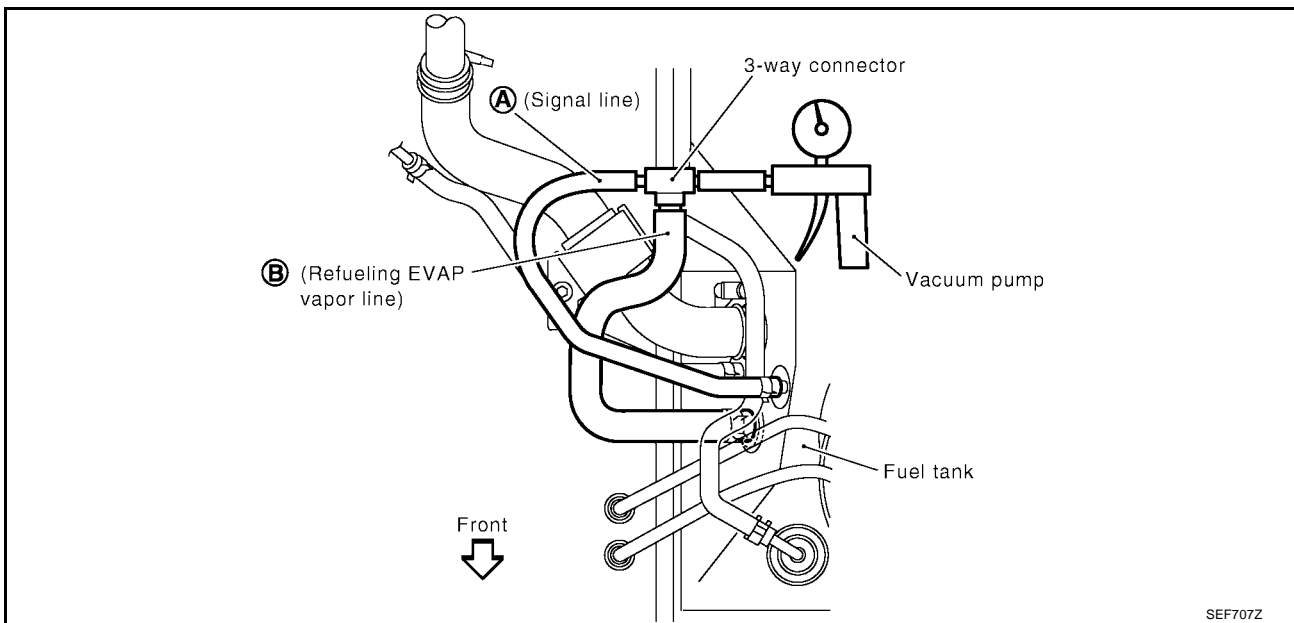

OK or NG

- OK >> GO TO 11.
- NG >> Replace refueling EVAP vapor cut valve with fuel tank.

---

## 16. CHECK HEATED OXYGEN SENSOR 1 (BANK 1) HARNESS

---

1. Stop engine and disconnect battery ground cable.
2. Disconnect ECM harness connector.
3. Disconnect heated oxygen sensor 1 (bank 1) harness connector.
4. Check harness continuity between ECM terminal 50 and heated oxygen sensor 1 (bank 1) harness connector.

**Continuity should exist.**

### OK or NG

- OK >> 1. Connect ECM harness connector.  
2. GO TO 18.
- NG >> 1. Repair or replace harness.  
2. GO TO 8 (With CONSULT-II).  
GO TO 9 (Without CONSULT-II).

---

## 17. CHECK HEATED OXYGEN SENSOR 1 (BANK 2) HARNESS

---

1. Stop engine and disconnect battery ground cable.
2. Disconnect ECM harness connector.
3. Disconnect heated oxygen sensor 1 (bank 2) harness connector.
4. Check harness continuity between ECM terminal 51 and heated oxygen sensor 1 (bank 2) harness connector.

**Continuity should exist.**

### OK or NG

- OK >> 1. Connect ECM harness connector.  
2. GO TO 18.
- NG >> 1. Repair or replace harness.  
2. GO TO 8 (With CONSULT-II).  
GO TO 9 (Without CONSULT-II).

**5. CHECK BASE IDLE SPEED****With CONSULT-II**

1. Select "TARGET IDLE RPM ADJ" in "WORK SUPPORT" mode and touch "START".
2. Check idle speed.

**M/T: 700±50 (in Neutral position)**

**A/T: 700±50 (in P or N position)**

**OK or NG**

OK >> GO TO 6.

NG >> 1. Adjust engine speed by turning idle speed adjusting screw. Refer to [EC-1201, "Idle Speed/Ignition Timing/Idle Mixture Ratio Adjustment"](#).

2. GO TO 6.

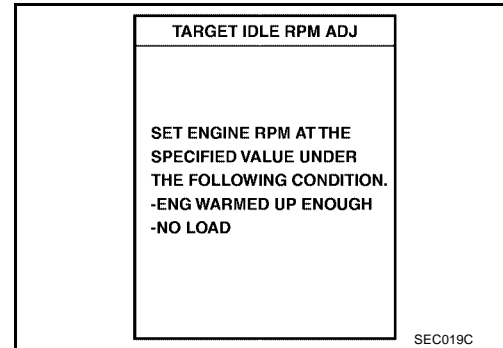
**6. CHECK CLOSED THROTTLE POSITION SWITCH IDLE POSITION-I****With CONSULT-II****NOTE:**

**Always check ignition timing and base idle speed before performing the following.**

1. Warm up engine to normal operating temperature.
2. Check FI cam, refer to procedure 3.
3. Stop engine.

>> GO TO 7.

## DTC Work Support Mode

Test mode	Test item	Condition	Reference page
EVAPRATIVE SYSTEM	EVAP SML LEAK P0442/P1442	Refer to corresponding trouble diagnosis for DTC.	<a href="#">EC-1496/EC-1638</a>
	EVAP V/S LEAK P0456/P1456		<a href="#">EC-1546/EC-1663</a>
	PURG VOL CN/V P1444		<a href="#">EC-1640</a>
	PURGE FLOW P0441		<a href="#">EC-1488</a>
	VC CUT/V BP/V P1491		<a href="#">EC-1682</a>
HO2S1	HO2S1 (B1) P0134		<a href="#">EC-1395</a>
	HO2S1 (B1) P1143		<a href="#">EC-1594</a>
	HO2S1 (B1) P1144		<a href="#">EC-1600</a>
	HO2S1 (B1) P0133		<a href="#">EC-1383</a>
	HO2S1 (B2) P0154		<a href="#">EC-1395</a>
	HO2S1 (B2) P1163		<a href="#">EC-1594</a>
	HO2S1 (B2) P1164		<a href="#">EC-1600</a>
	HO2S1 (B2) P0153		<a href="#">EC-1383</a>
HO2S2	HO2S2 (B1) P1146		<a href="#">EC-1607</a>
	HO2S2 (B1) P1147		<a href="#">EC-1617</a>
	HO2S2 (B1) P0139	<a href="#">EC-1414</a>	
	HO2S2 (B2) P1166	<a href="#">EC-1607</a>	
	HO2S2 (B2) P1167	<a href="#">EC-1617</a>	
	HO2S2 (B2) P0159	<a href="#">EC-1414</a>	

## REAL TIME DIAGNOSIS IN DATA MONITOR MODE (RECORDING VEHICLE DATA)

### Description

CONSULT-II has two kinds of triggers and they can be selected by touching "SETTING" in "DATA MONITOR" mode.

1. "AUTO TRIG" (Automatic trigger):

- The malfunction will be identified on the CONSULT-II screen in real time.

In other words, DTC/1st trip DTC and malfunction item will be displayed if the malfunction is detected by ECM.

At the moment a malfunction is detected by ECM, "MONITOR" in "DATA MONITOR" screen is changed to "Recording Data ... xx%" as shown at left, and the data after the malfunction detection is recorded. Then when the percentage reached 100%, "REAL-TIME DIAG" screen is displayed. If "STOP" is touched on the screen during "Recording Data ... xx%", "REAL-TIME DIAG" screen is also displayed. The recording time after the malfunction detection and the recording speed can be changed by "TRIGGER POINT" and "Recording Speed". Refer to CONSULT-II OPERATION MANUAL.

2. "MANU TRIG" (Manual trigger):

- DTC/1st trip DTC and malfunction item will not be displayed automatically on CONSULT-II screen even though a malfunction is detected by ECM.

DATA MONITOR can be performed continuously even though a malfunction is detected.

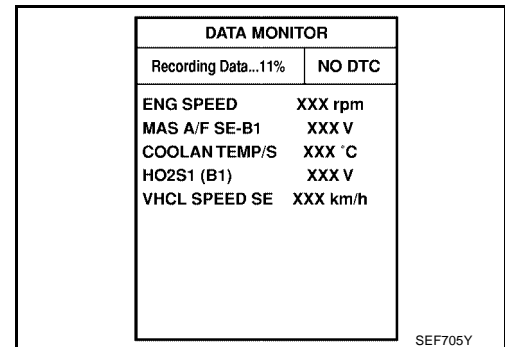

"REAL-TIME DIAG" screen is also displayed.

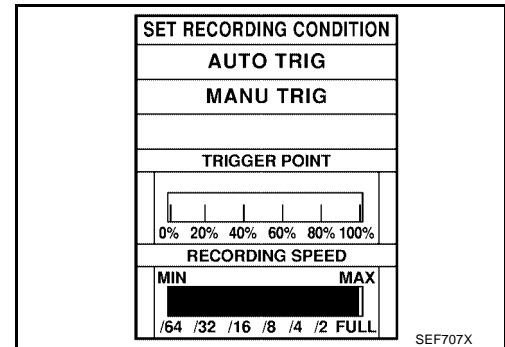

 **WITH CONSULT-II**

1. Turn ignition switch ON and select "DATA MONITOR" mode with CONSULT-II.
2. Start engine and warm it up to the normal operating temperature.
3. Turn ignition switch OFF and wait at least 10 seconds.
4. Start engine and keep the engine speed at between 3,500 and 4,000 rpm for at least 1 minute under no load.
5. Let engine idle for 1 minute.
6. If 1st trip DTC is detected, go to [EC-1319, "Diagnostic Procedure"](#).

DATA MONITOR	
MONITOR	NO DTC
ENG SPEED	XXX rpm
COOLAN TEMP/S	XXX °C

SEF174Y

 **WITH GST**

1. Start engine and warm it up to the normal operating temperature.
  2. Turn ignition switch OFF and wait at least 10 seconds.
  3. Start engine and keep the engine speed between 3,500 and 4,000 rpm for at least 1 minute under no load.
  4. Let engine idle for 1 minute.
  5. Turn ignition switch OFF and wait at least 10 seconds.
  6. Start engine and keep the engine speed between 3,500 and 4,000 rpm for at least 1 minute under no load.
  7. Let engine idle for 1 minute.
  8. Select MODE 3 with GST.
  9. If DTC is detected, go to [EC-1319, "Diagnostic Procedure"](#).
- **When using GST, DTC Confirmation Procedure should be performed twice as much as when using CONSULT-II because GST cannot display MODE 7 (1st trip DTC) concerning this diagnosis. Therefore, using CONSULT-II is recommended.**

A

EC

C

D

E

F

G

H

I

J

K

L

M

## On Board Diagnosis Logic

DTC No.	Trouble diagnosis name	DTC detecting condition		Possible cause
P0121	Throttle position sensor circuit range/performance problem	A)	A high voltage from the sensor is sent to ECM under light load driving condition.	<ul style="list-style-type: none"> <li>● Harness or connectors (The TP sensor circuit is open or shorted.)</li> <li>● TP sensor</li> <li>● Fuel injector</li> <li>● Camshaft position sensor</li> <li>● Mass air flow sensor</li> </ul>
		B)	A low voltage from the sensor is sent to ECM under heavy load driving condition.	<ul style="list-style-type: none"> <li>● Harness or connectors (The TP sensor circuit is open or shorted.)</li> <li>● Intake air leaks</li> <li>● TP sensor</li> </ul>

## DTC Confirmation Procedure

### NOTE:

- Perform **PROCEDURE FOR MALFUNCTION A** first. If the 1st trip DTC cannot be confirmed, perform **PROCEDURE FOR MALFUNCTION B**.
- If DTC Confirmation Procedure has been previously conducted, always turn ignition switch OFF and wait at least 5 seconds before conducting the next test.

### PROCEDURE FOR MALFUNCTION A

#### ④ With CONSULT-II

1. Turn ignition switch ON.
2. Select "DATA MONITOR" mode with CONSULT-II.
3. Start engine and let it idle for at least 10 seconds.  
If idle speed is over 1,000 rpm, maintain the following conditions for at least 10 seconds to keep engine speed below 1,000 rpm.

Selector lever	Suitable position except P or N
Brake pedal	Depressed
Vehicle speed	0 km/h (0 MPH)

4. If 1st trip DTC is detected, go to [EC-1353, "Diagnostic Procedure"](#).

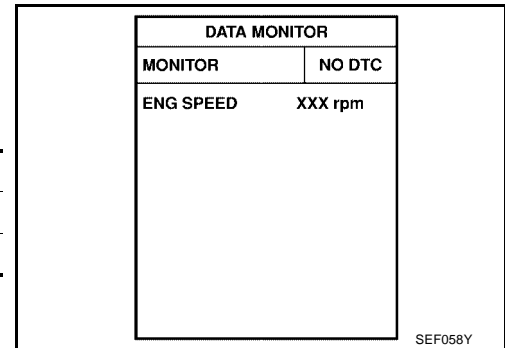

#### ④ With GST

Follow the procedure "With CONSULT-II" above.

### PROCEDURE FOR MALFUNCTION B

#### CAUTION:

**Always drive vehicle at a safe speed.**

#### ④ With CONSULT-II

1. Start engine and warm it up to normal operating temperature.
2. Turn ignition switch OFF and wait at least 5 seconds.
3. Turn ignition switch ON.
4. Select "MANU TRIG" in "DATA MONITOR" mode with CONSULT-II.

7. Make sure that "OK" is displayed after touching "SELF-DIAG RESULTS". If "NG" is displayed, refer to [EC-1389, "Diagnostic Procedure"](#).

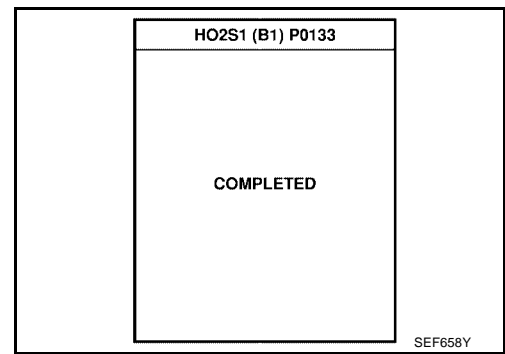

UBS008CE

## Overall Function Check

Use this procedure to check the overall function of the heated oxygen sensor 1 circuit. During this check, a DTC might not be confirmed.

### WITHOUT GST

1. Start engine and warm it up to normal operating temperature.
2. Set voltmeter probes between ECM terminal 50 [HOS1 (B1) signal] or 51 [HOS1 (B2) signal] and ground.
3. Check the following with engine speed held at 2,000 rpm constant under no load.
  - The voltage fluctuates between 0 to 0.3V and 0.6 to 1.0V more than 5 times within 10 seconds.

**1 time : 0 - 0.3V → 0.6 - 1.0V → 0 - 0.3V**

**2 times : 0 - 0.3V → 0.6 - 1.0V → 0 - 0.3V → 0.6 - 1.0V → 0 - 0.3V**

4. If NG, go to [EC-1389, "Diagnostic Procedure"](#).

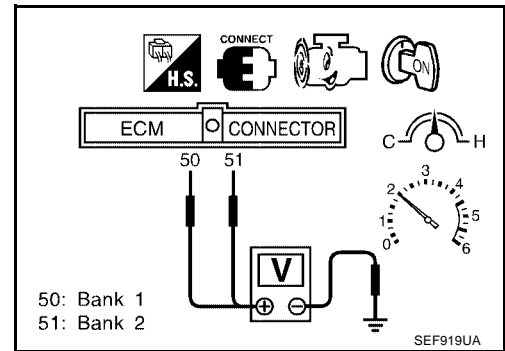

## 2. CLEAR THE SELF-LEARNING DATA

### WITH CONSULT-II

1. Start engine and warm it up to normal operating temperature.
2. Select "SELF-LEARNING CONT" in "WORK SUPPORT" mode with CONSULT-II.
3. Clear the self-learning control coefficient by touching "CLEAR".
4. Run engine for at least 10 minutes at idle speed.  
**Is the 1st trip DTC P0171, P0174 or P0172, P0175 detected?  
Is it difficult to start engine?**

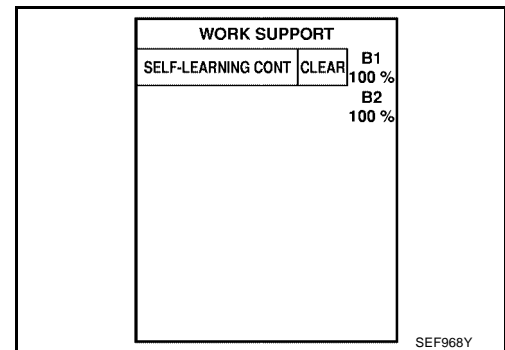

### WITHOUT CONSULT-II

1. Start engine and warm it up to normal operating temperature.
2. Turn ignition switch OFF.
3. Disconnect mass air flow sensor harness connector, and restart and run engine for at least 5 seconds at idle speed.
4. Stop engine and reconnect mass air flow sensor harness connector.
5. Make sure DTC P0102 is displayed.
6. Erase the DTC memory. Refer to [EC-1228, "HOW TO ERASE EMISSION-RELATED DIAGNOSTIC INFORMATION"](#).
7. Make sure DTC P0000 is displayed.
8. Run engine for at least 10 minutes at idle speed.  
**Is the 1st trip DTC P0171, P0174 or P0172, P0175 detected?  
Is it difficult to start engine?**

#### Yes or No

- Yes >> Perform trouble diagnosis for DTC P0171, P0174 or P0172, P0175. Refer to [EC-1424](#) or [EC-1432](#).
- No >> GO TO 3.

## 3. CHECK HO2S2 GROUND CIRCUIT FOR OPEN AND SHORT

1. Turn ignition switch OFF.
2. Disconnect heated oxygen sensor 2 harness connector.
3. Check harness continuity between HO2S2 terminal 4 and ground.  
Refer to Wiring Diagram.

**Continuity should exist.**

4. Also check harness for short to power.

#### OK or NG

- OK >> GO TO 4.
- NG >> Repair open circuit or short to power in harness or connectors.

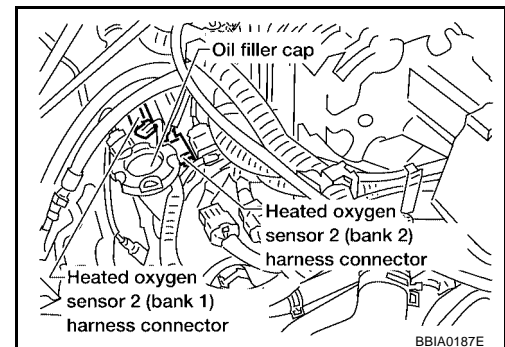

---

## 3. CHECK SUPERCHARGER DRIVING BELT

---

1. Visually check the supercharger driving belt for damage or worn.
2. Start engine and keep it at idle speed.
3. Check the supercharger driving belt for skipping.

**Is driving belt skipping, damaged or worn?**

Yes or No

- Yes >> Replace the supercharger drive belt.
- No >> GO TO 4.

---

## 4. CHECK INTERMITTENT INCIDENT

---

Refer to [EC-1292, "TROUBLE DIAGNOSIS FOR INTERMITTENT INCIDENT"](#) .

>> INSPECTION END.

A  
EC  
C  
D  
E  
F  
G  
H  
I  
J  
K  
L  
M

9. If NG, go to [EC-1490, "Diagnostic Procedure"](#).

**Diagnostic Procedure**

UBS008EQ

**1. CHECK EVAP CANISTER**

1. Turn ignition switch OFF.
2. Check EVAP canister for cracks.

OK or NG

- OK (With CONSULT-II)>>GO TO 2.
- OK (Without CONSULT-II)>>GO TO 3.
- NG >> Replace EVAP canister.

**2. CHECK PURGE FLOW**

**Ⓜ With CONSULT-II**

1. Disconnect vacuum hose connected to EVAP canister purge volume control solenoid valve at EVAP service port and install vacuum gauge.
2. Start engine and let it idle.
3. Select "PURG VOL CONT/V" in "ACTIVE TEST" mode with CONSULT-II.
4. Rev engine up to 2,000 rpm.

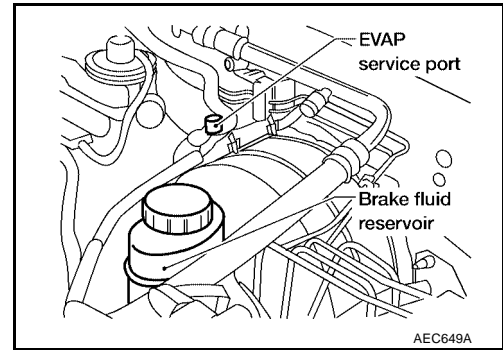

5. Touch "Qd" and "Qu" on CONSULT-II screen to adjust "PURG VOL CONT/V" opening.

PURG VOL CONT/V	VACUUM
100%	Should exist
0%	Should not exist

OK or NG

- OK >> GO TO 7.
- NG >> GO TO 4.

ACTIVE TEST	
PURG VOL CONT/V	XXX %
MONITOR	
ENG SPEED	XXX rpm
A/F ALPHA-B1	XX %
A/F ALPHA-B2	XX %
HO2S1 MNTR (B1)	LEAN
HO2S1 MNTR (B2)	LEAN
THRTL POS SEN	X. XX V

SEF677Y

**3. CHECK PURGE FLOW**

**⊗ Without CONSULT-II**

1. Start engine and warm it up to normal operating temperature.
2. Stop engine.
3. Disconnect vacuum hose connected to EVAP canister purge volume control solenoid valve at EVAP service port and install vacuum gauge.
4. Start engine and let it idle for at least 80 seconds.
5. Check vacuum gauge indication when revving engine up to 2,000 rpm.  
**Vacuum should exist.**
6. Release the accelerator pedal fully and let idle.  
**Vacuum should not exist.**

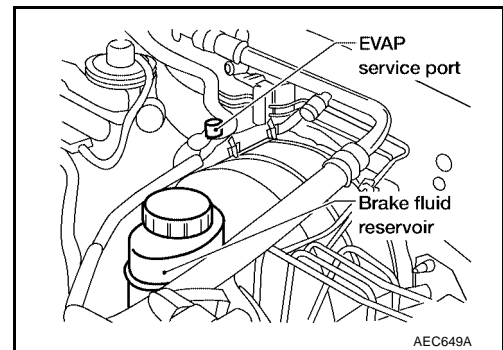

OK or NG

- OK >> GO TO 7.
- NG >> GO TO 4.

#### 4. CHECK EVAP CONTROL SYSTEM PRESSURE SENSOR POWER SUPPLY CIRCUIT

1. Turn ignition switch ON.
2. Check voltage between EVAP control system pressure sensor terminal 3 and ground with CONSULT-II or tester.

**Voltage: Approximately 5V**

OK or NG

- OK >> GO TO 6.  
NG >> GO TO 5.

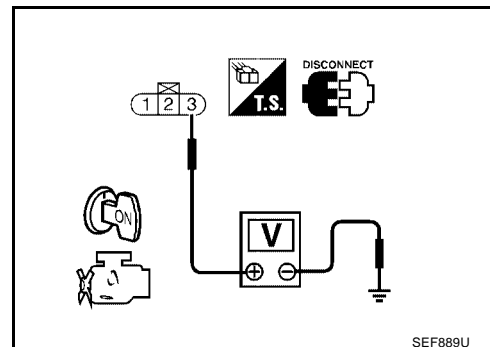

#### 5. DETECT MALFUNCTIONING PART

Check the following.

- Harness connectors C3, B113
- Harness connectors B101, M67
- Harness connectors M81, F36
- Harness for open or short between EVAP control system pressure sensor and ECM

>> Repair harness or connectors.

#### 6. CHECK EVAP CONTROL SYSTEM PRESSURE SENSOR GROUND CIRCUIT FOR OPEN AND SHORT

1. Turn ignition switch OFF.
2. Disconnect ECM harness connector.
3. Check harness continuity between EVAP control system pressure sensor terminal 1 and ECM terminal 43.  
Refer to Wiring Diagram.

**Continuity should exist.**

4. Also check harness for short to ground and short to power.

OK or NG

- OK >> GO TO 8.  
NG >> GO TO 7.

#### 7. DETECT MALFUNCTIONING PART

Check the following.

- Harness connectors C3, B113
- Harness connectors B101, M67
- Harness connectors M59, F27
- Harness for open or short between EVAP control system pressure sensor and ECM

>> Repair open circuit or short to ground or short to power in harness or connectors.

---

## 4. CHECK FUEL LEVEL SENSOR INPUT SIGNAL CIRCUIT FOR OPEN AND SHORT

---

1. Disconnect ECM harness connector.
2. Check harness continuity between ECM terminal 46 and fuel level sensor unit terminal 2, ECM terminal 66 and ground. Refer to Wiring Diagram.

**Continuity should exist.**

3. Also check harness for short to ground and short to power.

OK or NG

- OK >> GO TO 6.  
NG >> GO TO 5.

---

## 5. DETECT MALFUNCTIONING PART

---

Check the following.

- Harness connectors M91, B013
- Harness connectors M81, F36
- Harness for open or short between ECM and fuel level sensor unit
- Harness for open or short between ECM and ground

>> Repair open circuit or short to ground or short to power in harness or connectors.

---

## 6. CHECK FUEL LEVEL SENSOR

---

Refer to [DI-17, "FUEL LEVEL SENSOR UNIT CHECK"](#) .

OK or NG

- OK >> GO TO 7.  
NG >> Replace fuel level sensor unit.

---

## 7. CHECK INTERMITTENT INCIDENT

---

Refer to [EC-1292, "TROUBLE DIAGNOSIS FOR INTERMITTENT INCIDENT"](#) .

>> INSPECTION END.

### Removal and Installation FUEL LEVEL SENSOR

UBS008FX

Refer to [FL-6, "FUEL LEVEL SENSOR UNIT AND FUEL PUMP ASSEMBLY"](#) .

DTC No.	Trouble diagnosis name	DTC detecting condition	Possible cause
P1143 (Bank 1)	Heated oxygen sensor 1 lean shift monitoring	The maximum and minimum voltage from the sensor are not reached to the specified voltages.	<ul style="list-style-type: none"> <li>● Heated oxygen sensor 1</li> <li>● Heated oxygen sensor 1 heater</li> <li>● Fuel pressure</li> <li>● Fuel injector</li> <li>● Intake air leaks</li> </ul>
P1163 (Bank 2)			

## DTC Confirmation Procedure

UBS008HJ

**CAUTION:**

**Always drive vehicle at a safe speed.**

**NOTE:**

If DTC Confirmation Procedure has been previously conducted, always turn ignition switch OFF and wait at least 5 seconds before conducting the next test.

**TESTING CONDITION:**

- **Always perform at a temperature above -10°C (14°F).**
- **Before performing following procedure, confirm that battery voltage is more than 11V at idle.**

**WITH CONSULT-II**

1. Start engine and warm it up to normal operating temperature.
2. Stop engine and wait at least 5 seconds.
3. Turn ignition switch ON and select "HO2S1 (B1)/(B2) P1143/P1163" of "HO2S1" in "DTC WORK SUPPORT" mode with CONSULT-II.
4. Touch "START".
5. Start engine and let it idle for at least 3 minutes.

**NOTE:**

**Never raise engine speed above 2,800 rpm after this step. If the engine speed limit is exceeded, return to step 5.**

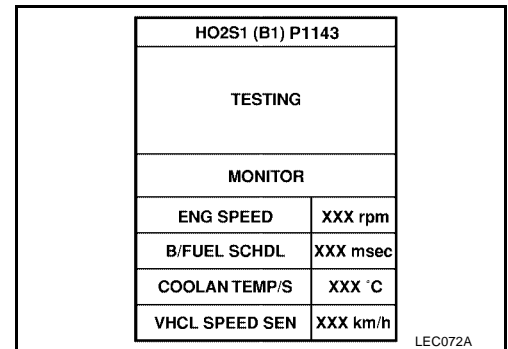

6. When the following conditions are met, "TESTING" will be displayed on the CONSULT-II screen. Maintain the conditions continuously until "TESTING" changes to "COMPLETED". (It will take approximately 50 seconds or more.)

EGN SPEED	1,200 - 2,700 rpm
Vehicle speed	Less than 100 km/h (62 MPH)
B/FUEL SCHDL	2.0 - 14.0 msec
Selector lever	Suitable position

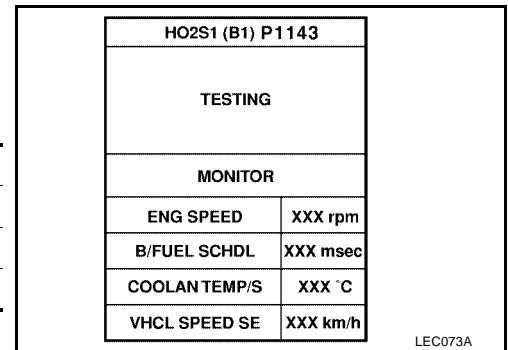

**If "TESTING" is not displayed after 5 minutes, retry from step 2.**

7. Make sure that "OK" is displayed after touching "SELF-DIAG RESULTS". If "NG" is displayed, refer to [EC-1596, "Diagnostic Procedure"](#).

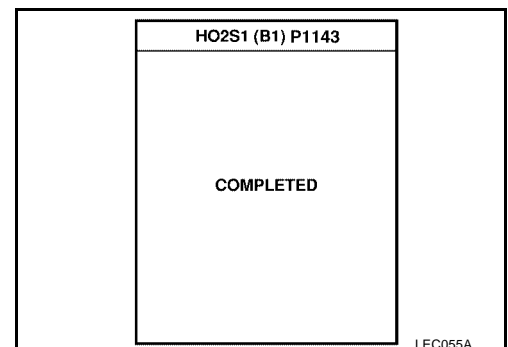

# DTC P1217 ENGINE OVER TEMPERATURE (OVERHEAT)

[VG33ER]

4. If NG, go to [EC-1630, "Diagnostic Procedure"](#).

## Diagnostic Procedure

UBS008IG

### 1. CHECK COOLING FAN (CRANKSHAFT DRIVEN) OPERATION

Start engine and make sure that cooling fan (crankshaft driven) operates.

OK or NG

OK >> GO TO 2.

NG >> Check cooling fan (crankshaft driven). Refer to [CO-31, "COOLING FAN \(CRANKSHAFT DRIVEN\)"](#).

### 2. CHECK COOLING SYSTEM FOR LEAK

Apply pressure to the cooling system with a tester, and check if the pressure drops.

#### CAUTION:

Higher than the specified pressure may cause radiator damage.

**Testing pressure<sup>2</sup> : 157 kPa (1.6 kg/cm, 23 psi)**

Pressure should not drop.

OK or NG

OK >> GO TO 3.

NG >> Check the following for leak

- Hose
- Radiator
- Water pump

Refer to [CO-25, "WATER PUMP"](#).

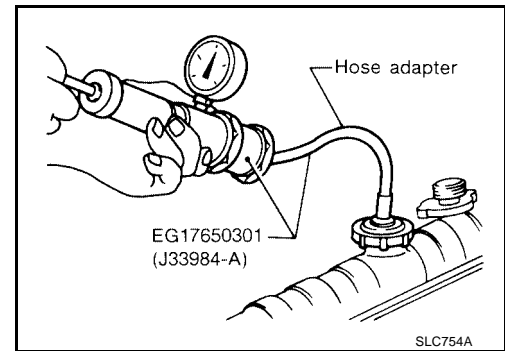

### 3. CHECK RADIATOR CAP

Apply pressure to cap with a tester and check radiator cap relief pressure.

**Radiator cap relief pressure : 59 - 98 kPa (0.6 - 1.0 kg/cm<sup>2</sup>, 9 - 14 psi)**

OK or NG

OK >> GO TO 4.

NG >> Replace radiator cap.

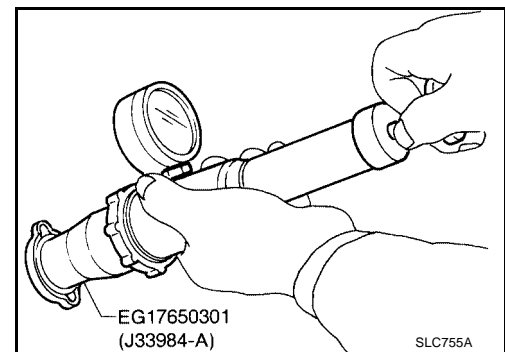

### 4. CHECK THERMOSTAT

1. Check valve seating condition at normal room temperatures.

**It should seat tightly.**

2. Check valve opening temperature and valve lift.

**Valve opening temperature : 76.5°C (170°F) [standard]**

**Valve lift : More than 10 mm/90°C (0.39 in/194°F)**

3. Check if valve is closed at 5°C (41°F) below valve opening temperature.

For details, refer to [CO-27, "THERMOSTAT"](#).

OK or NG

OK >> GO TO 5.

NG >> Replace thermostat

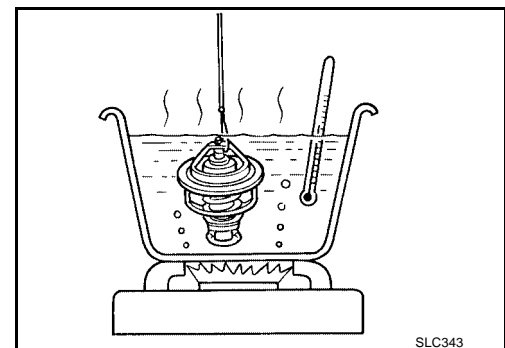

**NOTE:**

- If the engine speed cannot be maintained within the range displayed on CONSULT-II screen, go to [EC-1242, "Basic Inspection"](#) .
- Make sure that EVAP hoses are connected to EVAP canister purge volume control solenoid valve properly.

## Overall Function Check

UBS008.ID

### WITH GST

Use this procedure to check the overall function of the EVAP very small leak function. During this check, a 1st trip DTC might not be confirmed.

**CAUTION:**

- Never use compressed air, doing so may damage the EVAP system.
- Do not start engine.
- Do not exceeded 4.12 kPa (0.042 kg/cm<sup>2</sup> , 0.6 psi).

1. Attach the EVAP service port adapter securely to the EVAP service port.
2. Set the pressure pump and a hose.
3. Also set a vacuum gauge via 3-way connector and a hose.
4. Turn ignition switch ON.
5. Connect GST and select MODE 8.
6. Using MODE 8 control the EVAP canister vent control valve (close) and vacuum cut valve bypass valve (open).
7. Apply pressure and make sure the following conditions are satisfied.

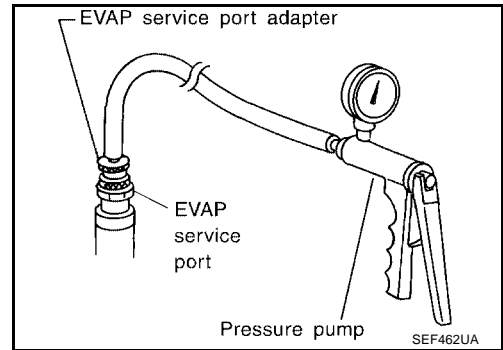

**Pressure to be applied: 2.7 kPa (20 mmHg, 0.79 inHg)**

**Time to be waited after the pressure drawn in to the EVAP system and the pressure to be dropped: 60 seconds and the pressure should not be dropped more than 0.4 kPa (3 mmHg, 0.12 inHg)**

If NG, go to [EC-1665, "Diagnostic Procedure"](#) .

**NOTE:**

For more information, refer to GST instruction manual.

## Diagnostic Procedure

UBS008.JE

### 1. CHECK FUEL FILLER CAP DESIGN

1. Turn ignition switch OFF.
2. Check for genuine NISSAN fuel filler cap design.

OK or NG

- OK >> GO TO 2.
- NG >> Replace with genuine NISSAN fuel filler cap.

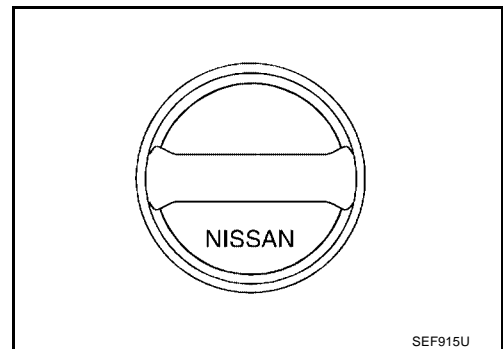

### 2. CHECK FUEL FILLER CAP INSTALLATION

- Check that the cap is tightened properly by rotating the cap clockwise.

OK or NG

- OK >> GO TO 3.
- NG >> 1. Open fuel filler cap, then clean cap and fuel filler neck threads using air blower.  
2. Retighten until ratcheting sound is heard.

## DTC P1706 PNP SWITCH

UBS008K3

### Component Description

When the gear position is P or N (A/T), Neutral (M/T), park/neutral position (PNP) switch is ON.

ECM detects the position because the continuity of the line (the ON signal) exists.

For A/T models, the park/neutral position (PNP) switch assembly also includes a transmission range switch to detect selector lever position.

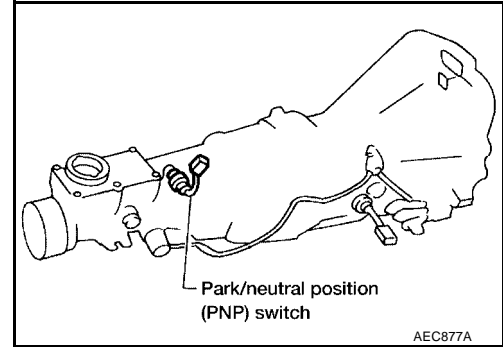

### CONSULT-II Reference Value in Data Monitor Mode

UBS008K4

Specification data are reference values.

MONITOR ITEM	CONDITION		SPECIFICATION
P/N POSI SW	● Ignition switch: ON	Shift lever: P or N (A/T), Neutral (M/T)	ON
		Except above	OFF

### On Board Diagnosis Logic

UBS008K5

DTC No.	Trouble diagnosis name	DTC detecting condition	Possible cause
P1706	Park/neutral position switch	The signal of the park/neutral position (PNP) switch is not changed in the process of engine starting and driving.	<ul style="list-style-type: none"> <li>● Harness or connectors [The park/neutral position (PNP) switch circuit is open or shorted.]</li> <li>● Park/neutral position (PNP) switch</li> </ul>

### DTC Confirmation Procedure

UBS008K6

**CAUTION:**

**Always drive vehicle at a safe speed.**

**NOTE:**

If DTC Confirmation Procedure has been previously conducted, always turn ignition switch OFF and wait at least 5 seconds before conducting the next test.

**WITH CONSULT-II**

1. Turn ignition switch ON.
2. Select "P/N POSI SW" in "DATA MONITOR" mode with CONSULT-II. Then check the "P/N POSI SW" signal under the following conditions.

Position (Selector lever)	Known good signal
N or P position (A/T) Neutral position (M/T)	ON
Except above position	OFF

If NG, go to [EC-1703, "Diagnostic Procedure"](#) .  
If OK, go to following step.

3. Select "DATA MONITOR" mode with CONSULT-II.
4. Start engine and warm it up to normal operating temperature.

DATA MONITOR	
MONITOR	NO DTC
P/N POSI SW	ON

SEF212Y

# IACV-FICD SOLENOID VALVE

[VG33ER]

Specification data are reference values and are measured between each terminal and ground.

**CAUTION:**

Do not use ECM ground terminals when measuring input/output voltage. Doing so may result in damage to the ECM's transistor. Use a ground other than the ECM terminals, such as the ground.

TER-MINAL NO.	WIRE COLOR	ITEM	CONDITION	DATA (DC Voltage)
9	B/Y	Ambient air temperature switch	<b>[Engine is running]</b> <ul style="list-style-type: none"> <li>● Idle speed</li> <li>● Ambient air temperature is above 25°C (77°F)</li> <li>● Air conditioner is operating</li> </ul>	0V
			<b>[Engine is running]</b> <ul style="list-style-type: none"> <li>● Idle speed</li> <li>● Ambient air temperature is below 19°C (66°F)</li> <li>● Air conditioner is operating</li> </ul>	BATTERY VOLTAGE (11 - 14V)
			<b>[Engine is running]</b> <ul style="list-style-type: none"> <li>● Idle speed</li> <li>● Ambient air temperature is below 19°C (66°F)</li> <li>● Air conditioner is not operating</li> </ul>	Approximately 5V
12	P	Air conditioner relay	<b>[Engine is running]</b> <ul style="list-style-type: none"> <li>● Both A/C switch and blower switch are ON*</li> </ul>	0 - 1V
			<b>[Engine is running]</b> <ul style="list-style-type: none"> <li>● A/C switch is OFF</li> </ul>	BATTERY VOLTAGE (11 - 14V)

\*: Any mode except OFF, ambient air temperature is above 25°C (77°F).

## Diagnostic Procedure

### 1. CHECK OVERALL FUNCTION

1. Start engine and warm it up to normal operating temperature.
2. Check idle speed.

**M/T: 750±50 rpm (in Neutral position)**

**A/T: 750±50 rpm (in P or N position)**

If NG, adjust idle speed.

3. Turn air conditioner switch and blower fan switch ON.
4. Recheck idle speed.

**M/T: 850 rpm or more (in Neutral position)**

**A/T: 850 rpm or more (in P or N position)**

OK or NG

OK >> **INSPECTION END.**

NG >> GO TO 2.

### 2. CHECK AIR CONDITIONER FUNCTION

Check if air conditioner compressor functions normally.

OK or NG

OK >> GO TO 3.

NG >> Refer to [MTC-23, "SYMPTOM TABLE"](#).

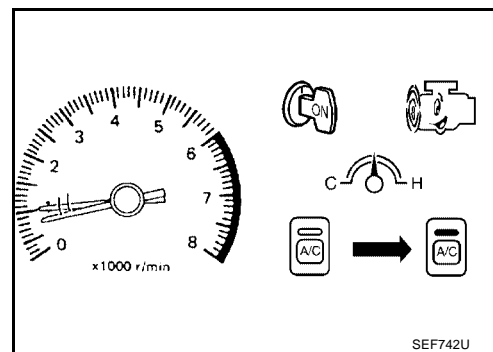

SEF742U

# BODY FRONT END

---

## BODY FRONT END

PFPP:H5022

### Removal and Installation

EIS00149

- When removing or installing hood, place a cloth or other padding on hood. This prevents vehicle body from being scratched.
- Bumper fascia is made of plastic. Do not use excessive force and be sure to keep oil away from it.
- Hood adjustment: Adjust at hinge portion.
- Hood lock adjustment: After adjusting, check hood lock control operation. Apply a coat of grease to hood locks engaging mechanism.
- Hood opener: Do not attempt to bend cable forcibly. Doing so increases effort required to unlock hood.

### FRONT BUMPER ASSEMBLY

1. Remove clips securing front grille and remove the front grille. **B**
2. Remove the side marker lamps.
3. Remove bolts securing left and right bumper stays. **C**
4. Remove the lower grille opening trim. **A**
5. Remove bolts securing left and right bumper side brackets. **D**
6. Remove the front fascia.
7. Remove bolts securing left and right bumper from bumper brackets. **E**
8. Remove bumper assembly.

## Intake manifold

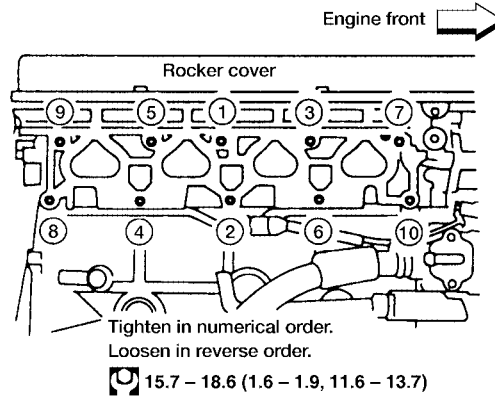

## Exhaust manifold

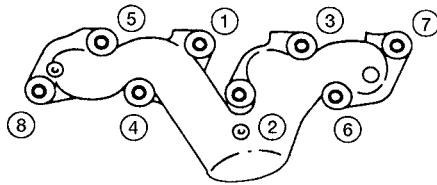

Tighten in numerical order.  
Loosen in reverse order.

37.3 - 48.0 (3.8 - 4.9, 27.5 - 35.4)

: N·m (kg-m, ft-lb)

## Throttle body

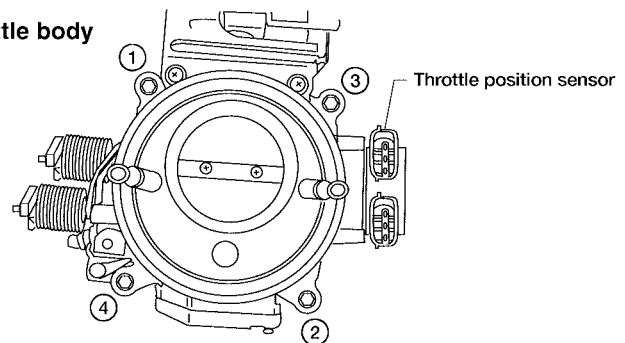

Tighten in numerical order.  
Loosen in reverse order.

1st: 9 - 11 (0.9 - 1.1, 6.5 - 8.0)  
2nd: 18 - 22 (1.8 - 2.2, 13 - 16)

WBIA0099E

A  
EM  
C  
D  
E  
F  
G  
H  
I  
J  
K  
L  
M

# CYLINDER BLOCK

[KA24DE]

- Bend limit** : 0.15 mm (0.0059 in) per 100 mm (3.94 in) length
- Torsion limit** : 0.30 mm (0.0118 in) per 100 mm (3.94 in) length

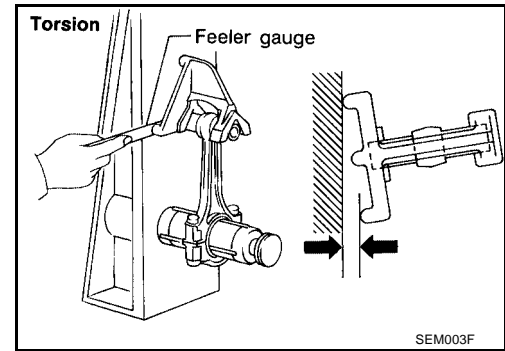

## CYLINDER BLOCK DISTORTION AND WEAR

1. Clean the upper face of the cylinder block.
2. Use a reliable straightedge and feeler gauge to check the flatness of the cylinder block upper face surface. Check along the six positions as shown.

### Cylinder block distortion

**Standard** : —

**Limit** : 0.1 mm (0.004 in)

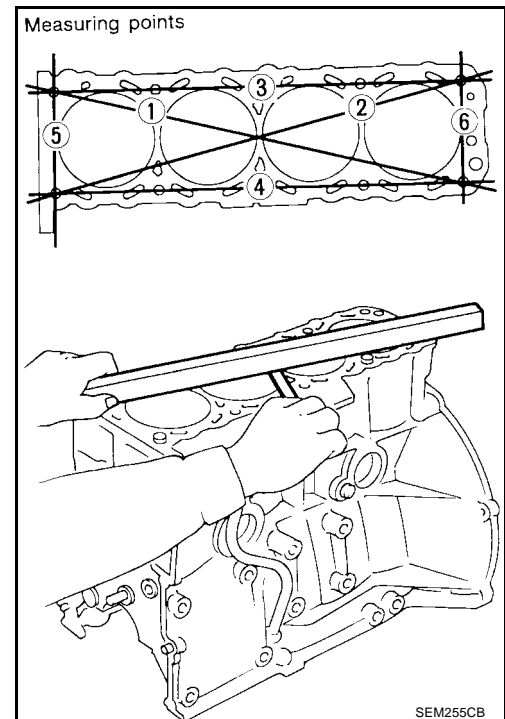

3. If the block distortion exceeds specification, resurface the block. Replace the block if necessary.

- The limit for cylinder block resurfacing is determined by cylinder head resurfacing.

**Amount of cylinder head resurfacing is "A"**

**Amount of cylinder block resurfacing is "B"**

**Nominal block height at crankshaft center** : 246.95 - 247.05 mm (9.7224 - 9.7264 in)

**Max. block distortion limit = A + B** : 0.2 mm (0.008 in)

## PISTON-TO-CYLINDER BORE CLEARANCE

1. Using a bore gauge to measure the cylinder bore for wear, out-of-round, and taper. If the clearance exceeds the limit, rebore all of the cylinders. Replace the cylinder block if necessary.

**Standard inner bore diameter** : Refer to [EM-65, "Cylinder Block"](#).

**Out-of-round (X – Y) standard** : 0.015 mm (0.0006 in)

**Taper (A – B) standard** : 0.010 mm (0.0004 in)

**Wear limit** : 0.2 mm (0.008 in)

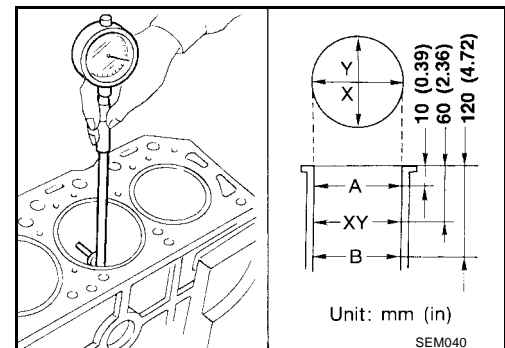

## OIL PAN

## Removal

**WARNING:**

- Place the vehicle on a flat and solid surface.
- Place chocks at the front and rear of the rear tires.
- Do not remove the oil pan until the exhaust system and cooling system have completely cooled off. You may burn yourself. There is the possibility that fire may break out in the fuel line.
- When removing the front and rear engine mounting bolts or nuts, lift the engine slightly for safe removal.

**CAUTION:**

- When lifting the engine, do not crush or damage any adjacent parts, with special attention to the accelerator wire casing end, brake tube, and brake master cylinder.
1. Remove the engine undercover.
  2. Drain the engine oil.
  3. Remove the RH and LH stabilizer bracket bolts. Refer to [FSU-17, "Removal"](#) .
  4. Remove the front propeller shaft from the front differential carrier. Refer to [PR-8, "Removal and Installation"](#) .
  5. Remove the RH and LH front drive shaft fixing bolts. Refer to [FAX-20, "Removal"](#) .
  6. Remove the front differential carrier bleeder hose.
  7. Remove the front suspension cross member. Refer to [FSU-5, "Components"](#) .
  8. Remove the RH and LH differential front mounting bolts and the rear mounting bolts. Refer to [FFD-9, "Removal and Installation"](#) .
  9. Remove the front differential carrier. Refer to [FFD-9, "Removal and Installation"](#) .
  10. Remove the front differential carrier mounting bracket. Refer to [FFD-9, "Removal and Installation"](#) .
  11. Remove the starter motor. Refer to [SC-23, "Removal"](#) .
  12. Remove the RH and LH transmission to rear engine mounting bracket nuts. Refer to [EM-124, "Removal and Installation"](#) .
  13. Remove the RH and LH engine mounting bolts or nuts. Refer to [EM-124, "Removal and Installation"](#) .
  14. Remove the power steering gear mounting brackets. Refer to [PS-15, "Removal and Installation"](#) .
  15. Lift up the engine. If necessary, disconnect the exhaust tube. Refer to [EX-3, "Removal and Installation"](#) .
  16. Remove the relay rod. Refer to [FSU-5, "Components"](#) .

**NOTE:**

It is not necessary to disconnect the pitman arm.

17. Remove the oil pan bolts, loosen the oil pan bolts in the numerical order as shown.

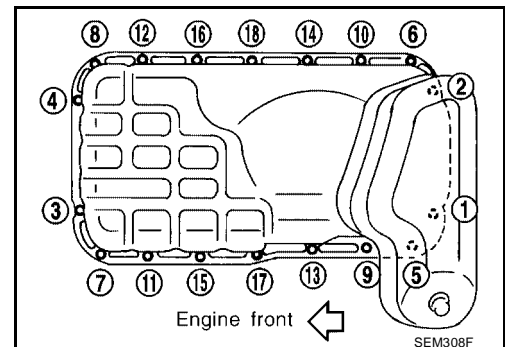

# SUPERCHARGER

[VG33E and VG33ER]

## SUPERCHARGER

PF14110

### Components

EBS00CB9

SEC. 140 • 147 • 148 • 163 • 164 • 173 • 210 • 221

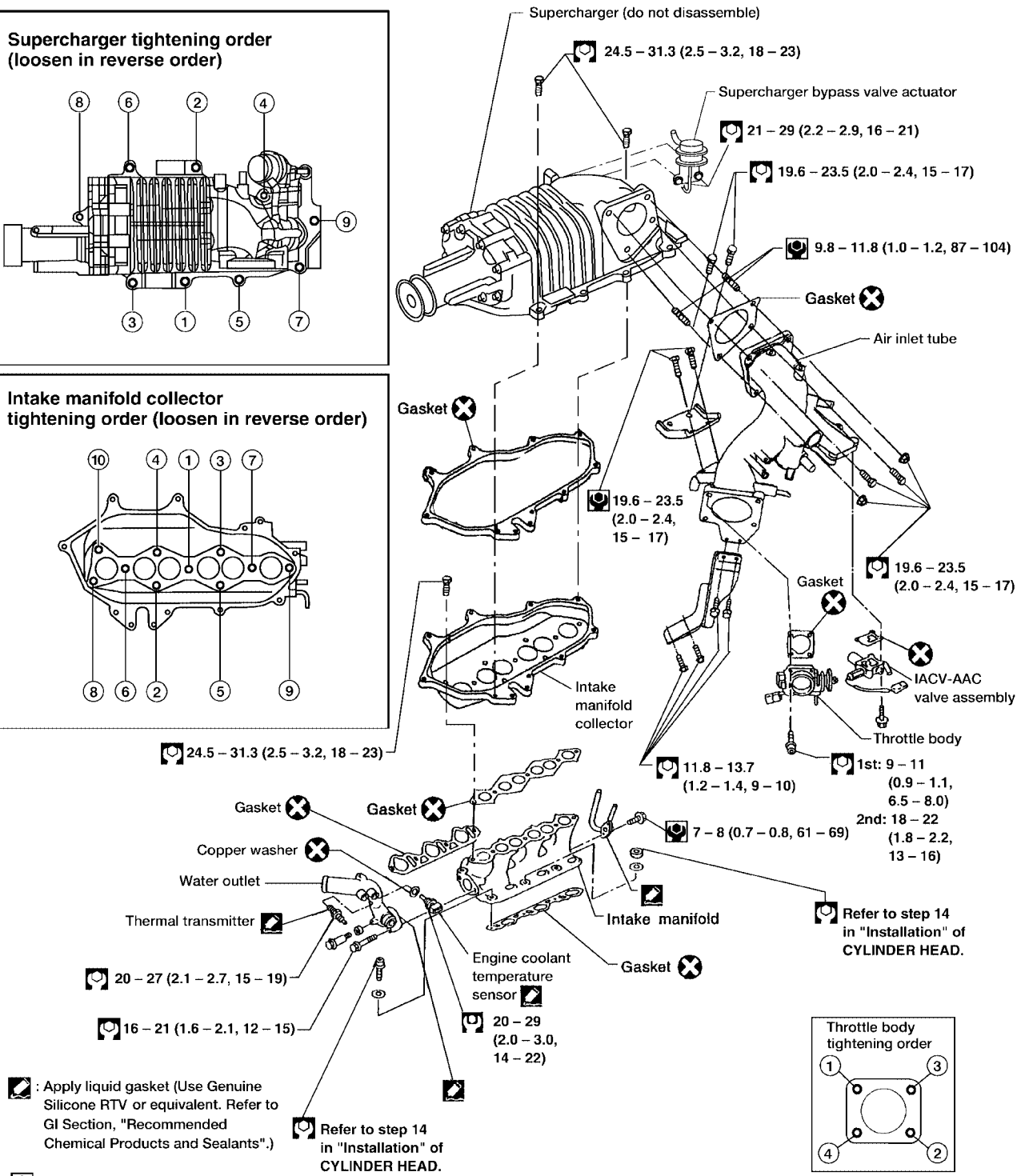
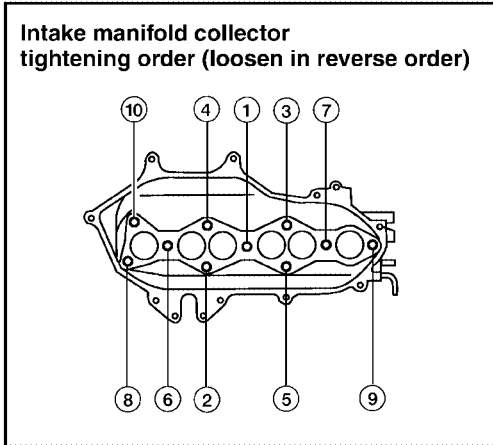
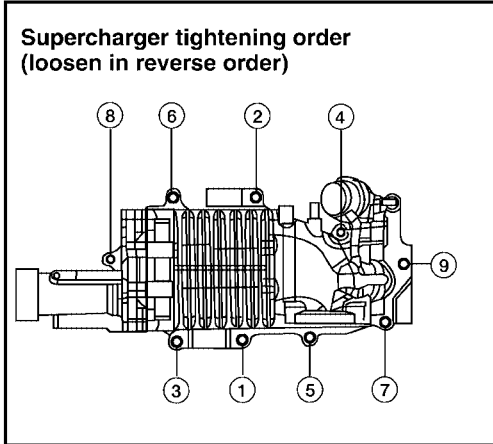

- : Apply liquid gasket (Use Genuine Silicone RTV or equivalent. Refer to GI Section, "Recommended Chemical Products and Sealants".)
- : Refer to step 14 in "Installation" of CYLINDER HEAD.
- : N-m (kg-m, in-lb)
- : N-m (kg-m, ft-lb)

# EXHAUST SYSTEM

## VG33E 2WD Models

SEC. 200

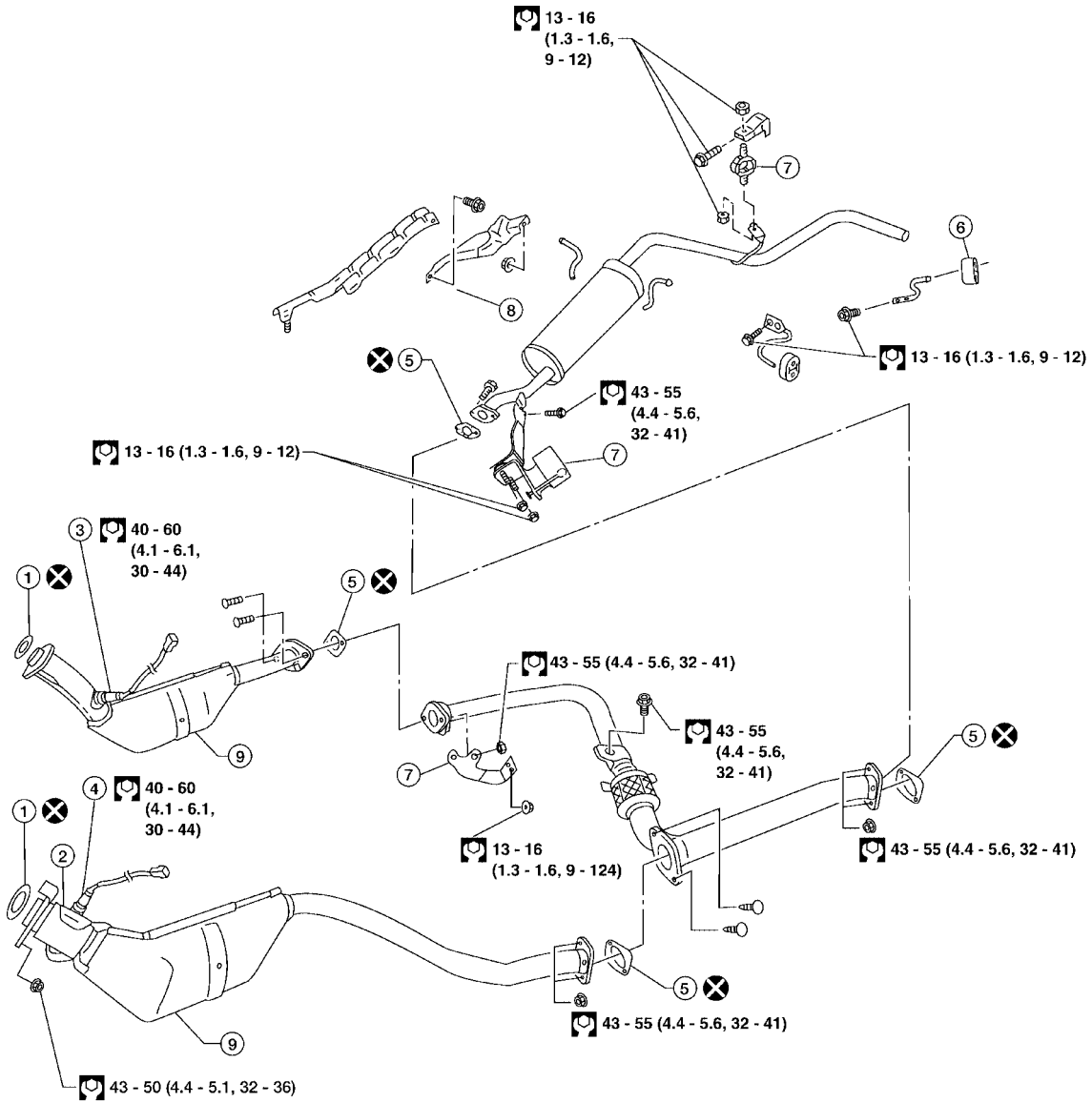

- : N-m (kg-m, in-lb)
- : N-m (kg-m, ft-lb)
- : Always replace after every disassembly.

- |                                    |                   |                                    |
|------------------------------------|-------------------|------------------------------------|
| 1. Gasket                          | 2. Front tube     | 3. Heated oxygen sensor 2 (bank 1) |
| 4. Heated oxygen sensor 2 (bank 2) | 5. Gasket         | 6. Mounting rubber                 |
| 7. Mounting bracket                | 8. Center muffler | 9. Three way convertor             |

WBIA0429E

# PREPARATION

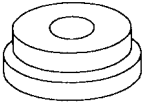
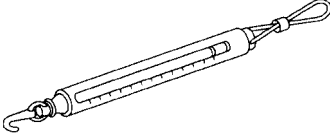
Tool number (Kent-Moore No.) Tool name	Description
<p>(J25269-4) Side bearing discs (2 Req'd)</p>  <p>NT136</p>	Selecting drive pinion height adjusting washer
<p>(J8129) Spring gauge</p>  <p>NT127</p>	Measuring differential case assembly turning resistance

# FUEL TANK

11. Remove fuel tank mounting bolts while supporting fuel tank.

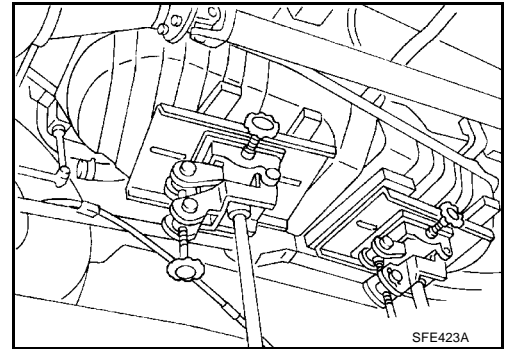

12. Remove fuel tank.

## INSTALLATION

Installation is in the reverse order of removal.  
Connect the quick connectors as follows:

- Make sure the connectors are clean and undamaged.
- Align push in tabs with retainer openings.

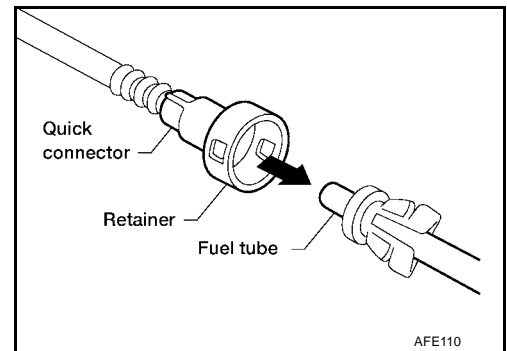

● Insert tube into the center of the connector until you hear a click.  
After connecting quick connectors, make sure the connection is fully seated and locked in place as follows:

- Pull on the fuel tube and connector to make sure they are properly connected.
- Start the engine, increase engine speed and verify that there are no leaks.

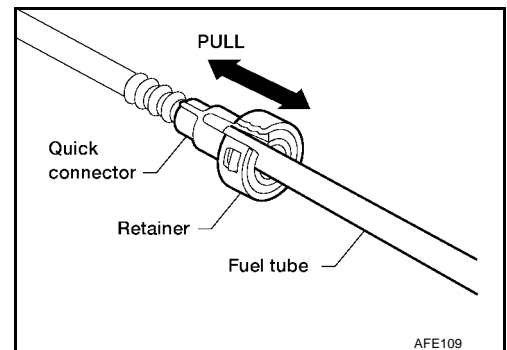

# HOW TO USE THIS MANUAL

## HOW TO USE THIS MANUAL

PFP:00008

### Description

EAS000YG

This volume explains “Removal, Disassembly, Installation, Inspection and Adjustment” and “Trouble Diagnoses”.

### Terms

EAS000YH

- The captions **WARNING** and **CAUTION** warn you of steps that must be followed to prevent personal injury and/or damage to some part of the vehicle.  
**WARNING** indicates the possibility of personal injury if instructions are not followed.  
**CAUTION** indicates the possibility of component damage if instructions are not followed.  
**BOLD TYPED STATEMENTS** except **WARNING** and **CAUTION** give you helpful information.  
Standard value:Tolerance at inspection and adjustment.  
Limit value:The maximum or minimum limit value that should not be exceeded at inspection and adjustment.

### Units

EAS000YI

- The **UNITS** given in this manual are primarily expressed as the SI UNIT (International System of Unit), and alternatively expressed in the metric system and in the yard/pound system.  
“Example”

**Outer Socket Lock Nut : 59 - 78 N-m (6.0 - 8.0 kg-m, 43 - 58 ft-lb)**

### Contents

EAS000YJ

- **ALPHABETICAL INDEX** is provided at the end of this manual so that you can rapidly find the item and page you are searching for.
- **A QUICK REFERENCE INDEX**, a black tab (e.g. **BR**) is provided on the first page. You can quickly find the first page of each section by matching it to the section's black tab.
- **THE CONTENTS** are listed on the first page of each section.
- **THE TITLE** is indicated on the upper portion of each page and shows the part or system.
- **THE PAGE NUMBER** of each section consists of two or three letters which designate the particular section and a number (e.g. “BR-5”).
- **THE SMALL ILLUSTRATIONS** show the important steps such as inspection, use of special tools, knacks of work and hidden or tricky steps which are not shown in the previous large illustrations. Assembly, inspection and adjustment procedures for the complicated units such as the automatic transaxle or transmission, etc. are presented in a step-by-step format where necessary.

### How to Follow Trouble Diagnoses

EAS000XR

#### NOTICE:

Trouble diagnoses indicates work procedures required to diagnose problems effectively. Observe the following instructions before diagnosing.

1. **Before performing trouble diagnoses, read the “Preliminary Check”, the “Symptom Chart” or the “Work Flow”.**
2. **After repairs, re-check that the problem has been completely eliminated.**
3. **Refer to Component Parts and Harness Connector Location for the Systems described in each section for identification/location of components and harness connectors.**
4. **Refer to the Circuit Diagram for quick pinpoint check.**  
**If you need to check circuit continuity between harness connectors in more detail, such as when a sub-harness is used, refer to Wiring Diagram in each individual section and Harness Layout in EL section for identification of harness connectors.**
5. **When checking circuit continuity, ignition switch should be OFF.**
6. **Before checking voltage at connectors, check battery voltage.**
7. **After accomplishing the Diagnostic Procedures and Electrical Components Inspection, make sure that all harness connectors are reconnected as they were.**

# IDENTIFICATION INFORMATION

## IDENTIFICATION INFORMATION

PFP:00010

### Model Variation

EAS000Y7

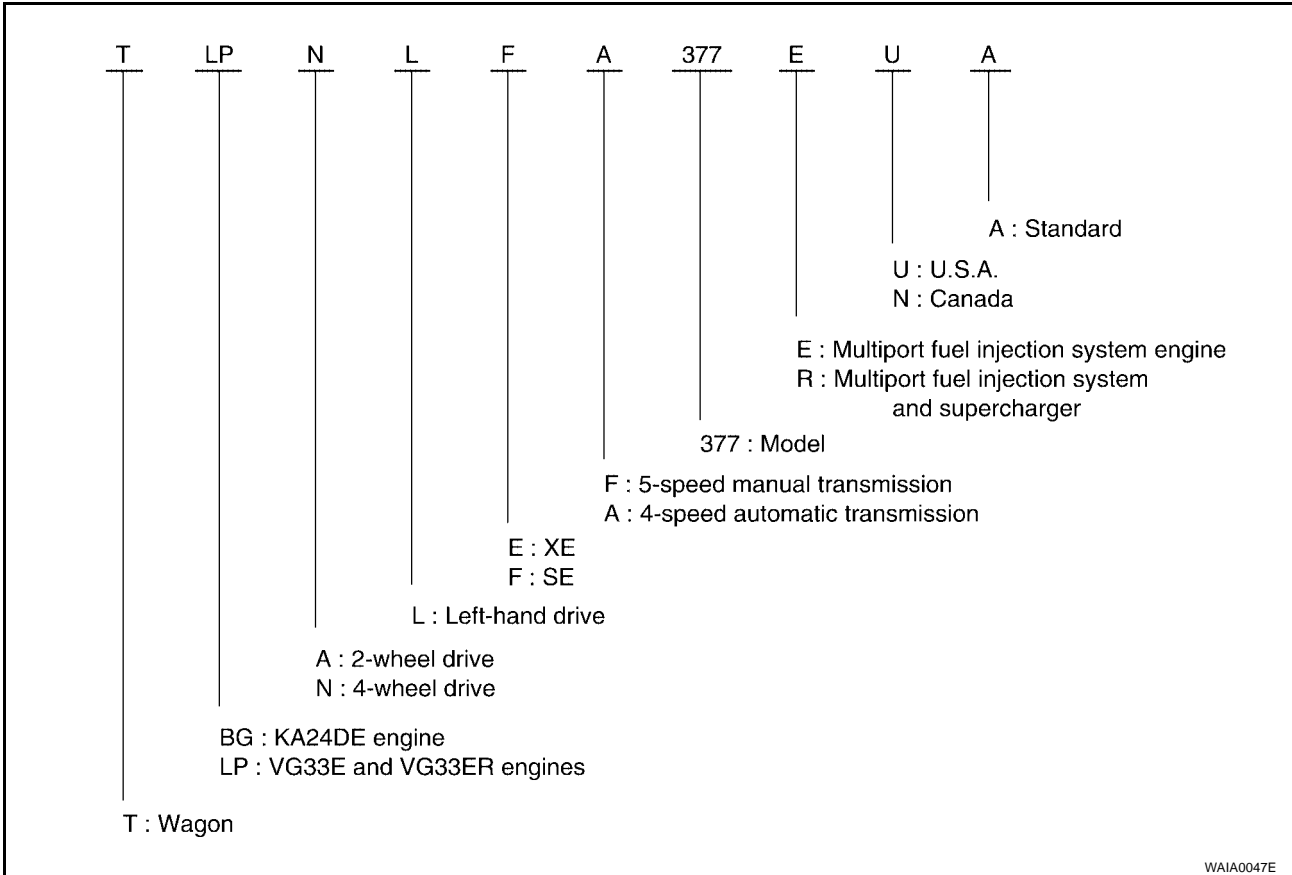

GI

B

C

D

E

F

G

H

I

J

K

L

M

# DOOR MIRROR

PF9:96301

EIS00140

## DOOR MIRROR

### Wiring Diagram — MIRROR —

GW-MIRROR-01

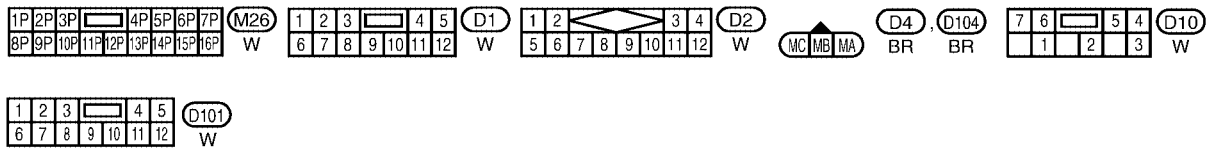
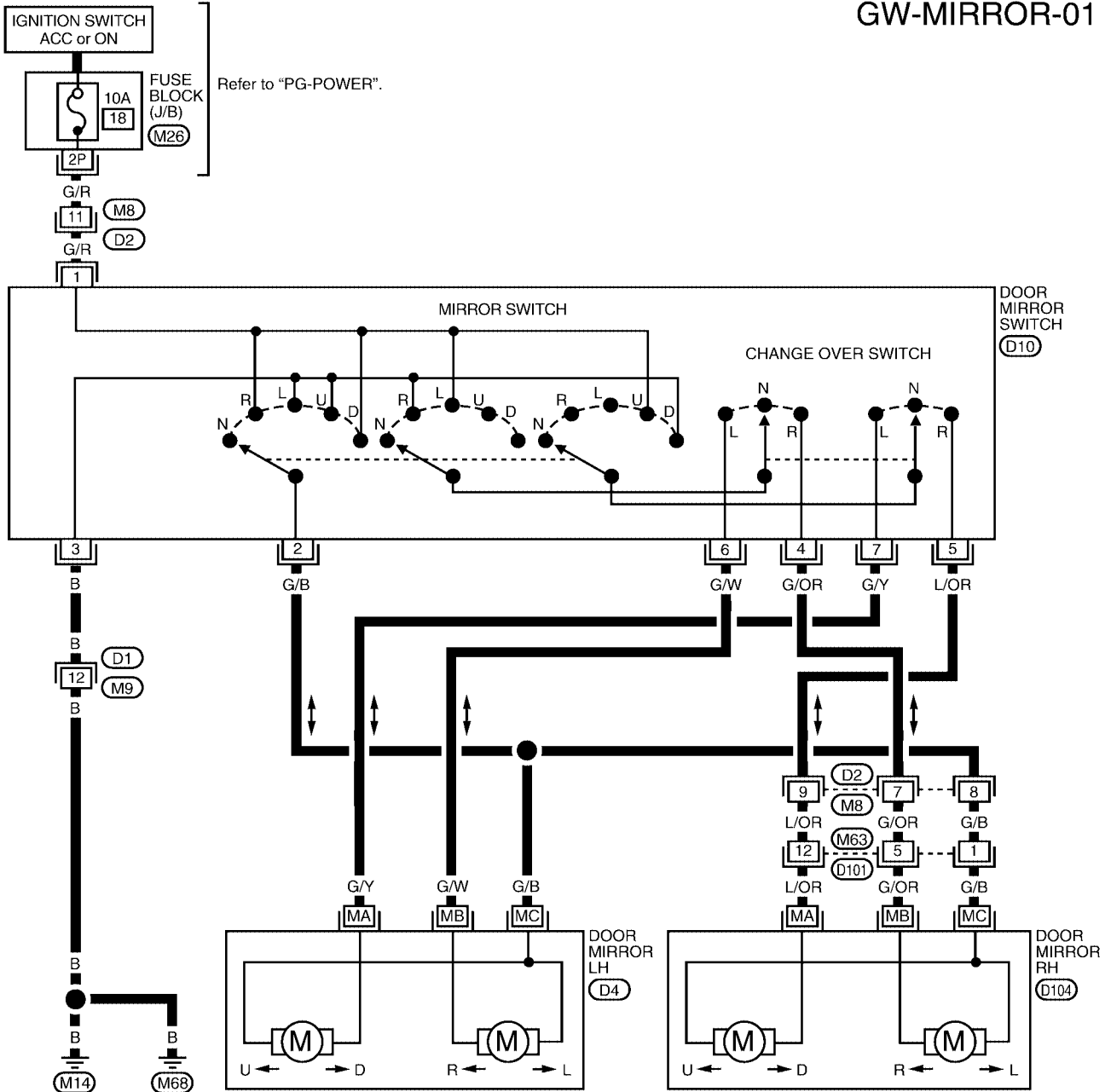

# INSTRUMENT PANEL ASSEMBLY

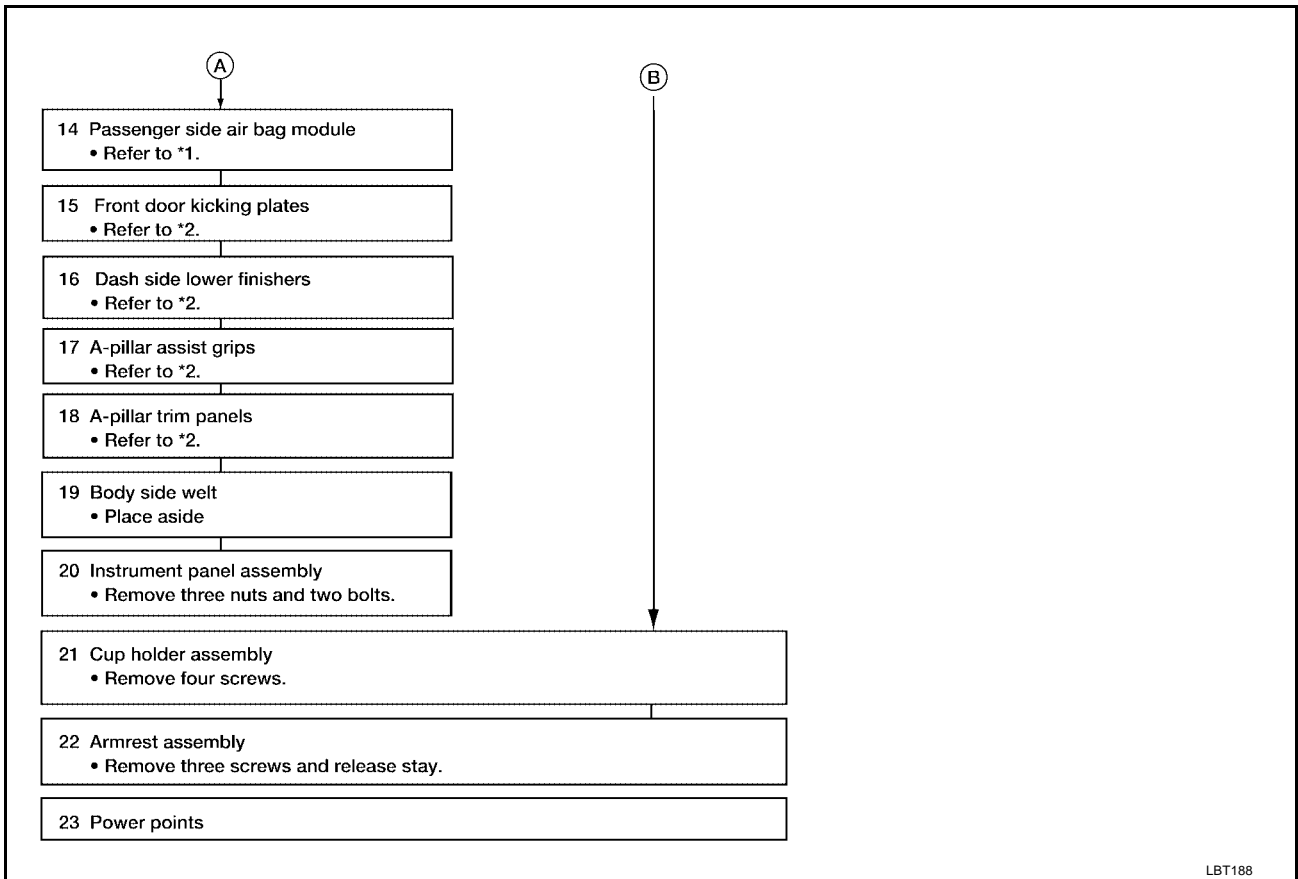

\*1 [SRS-47](#)

\*2 [EI-18](#)

A

B

C

D

E

F

G

H

IP

J

K

L

M

# TRAILER TOW

EKS0031Z

## Trouble Diagnoses TRAILER TOW CONTROL UNIT INSPECTION TABLE

Terminal No.	Wire color	Item	Condition	Voltage (Approx.)
1	G/R	RH turn lamps input	When RH turn lamps or hazard lamps operate	12 (intermittently)
			All other conditions	0
3	BR/R	Stop lamps signal input	When brake pedal is depressed	12
			When brake pedal is released	0
4	G/Y	LH turn lamps input	When LH turn lamps or hazard lamps operate	12 (intermittently)
			All other conditions	0
5	G	Stop/RH turn lamp (output)	When brake pedal is depressed	12
			When RH turn lamps or hazard lamps operate	12 (intermittently)
			All other conditions	0
6	R/B	Power supply	—	12
7	B	Ground	—	—
8	Y	Stop/LH turn lamp (output)	When brake pedal is depressed	12
			When LH turn lamps or hazard lamps operate	12 (intermittently)
			All other conditions	0

**SECTION MA**  
**MAINTENANCE**

A  
B  
C

**CONTENTS**

<p><b>PRECAUTIONS ..... 3</b>                  Precautions for Supplemental Restraint System (SRS) "AIR BAG" and "SEAT BELT PRE-TENSIONER" ..... 3</p> <p><b>PREPARATION ..... 4</b>                  Special Service Tools ..... 4                  Commercial Service Tool ..... 4</p> <p><b>GENERAL MAINTENANCE ..... 5</b>                  General Maintenance ..... 5</p> <p><b>PERIODIC MAINTENANCE ..... 7</b>                  Periodic Maintenance ..... 7                  SCHEDULE 1 ..... 7                  SCHEDULE 2 ..... 10</p> <p><b>RECOMMENDED FLUIDS AND LUBRICANTS ..... 12</b>                  Recommended Fluids and Lubricants ..... 12                  FLUIDS AND LUBRICANTS ..... 12                  SAE VISCOSITY NUMBER ..... 14                  ANTI-FREEZE COOLANT MIXTURE RATIO .... 14</p> <p><b>ENGINE MAINTENANCE (KA24DE) ..... 15</b>                  Checking Drive Belts ..... 15                  DRIVE BELT DEFLECTION AND TENSION .... 16                  Changing Engine Coolant ..... 16                  DRAINING ENGINE COOLANT ..... 16                  REFILLING ENGINE COOLANT ..... 17                  FLUSHING COOLING SYSTEM ..... 18                  Checking Fuel Lines ..... 18                  Changing Fuel Filter ..... 18                  WITH CONSULT - II ..... 18                  WITHOUT CONSULT - II ..... 19                  Changing Air Cleaner Filter ..... 20                  Changing Engine Oil ..... 20                  Changing Oil Filter ..... 21                  Changing Spark Plugs ..... 22                  Checking EVAP Vapor Lines ..... 23                  Changing Positive Crankcase Ventilation (PCV) Filter ..... 23</p> <p><b>ENGINE MAINTENANCE (VG33E AND VG33ER).. 24</b>                  Checking Drive Belts ..... 24                  DRIVE BELT DEFLECTION AND TENSION .... 25                  Changing Engine Coolant ..... 26</p>	<p>DRAINING ENGINE COOLANT ..... 26                  REFILLING ENGINE COOLANT ..... 26                  FLUSHING COOLING SYSTEM ..... 28                  Checking Fuel Lines ..... 28                  Changing Fuel Filter ..... 28                  WITH CONSULT - II ..... 28                  WITHOUT CONSULT - II ..... 29                  Changing Air Cleaner Filter ..... 30                  VISCOUS PAPER TYPE ..... 30                  Changing Engine Oil ..... 30                  Changing Oil Filter ..... 31                  Changing Spark Plugs ..... 32                  Checking EVAP Vapor Lines ..... 34</p> <p><b>CHASSIS AND BODY MAINTENANCE ..... 35</b>                  Changing In-cabin Microfilter ..... 35                  Checking Exhaust System ..... 35                  Checking Clutch Fluid Level and Leaks ..... 35                  Checking M/T Oil ..... 35                  Changing M/T Oil ..... 35                  Checking Water Entry — For 4X4 Models With M/T.. 36                  Checking A/T Fluid ..... 36                  Changing A/T Fluid ..... 37                  Checking Transfer Fluid ..... 37                  Changing Transfer Fluid ..... 37                  Checking Propeller Shaft ..... 38                  Greasing Propeller Shaft ..... 38                  Checking Differential Gear Oil ..... 38                  Changing Differential Gear Oil ..... 39                  LIMITED-SLIP DIFFERENTIAL GEAR ..... 39                  Balancing Wheels ..... 40                  Tire Rotation ..... 40                  Checking Brake Fluid Level and Leaks ..... 40                  Checking Brake Lines and Cables ..... 40                  Checking Disc Brake ..... 41                  ROTOR ..... 41                  CALIPER ..... 41                  PAD ..... 41                  Checking Drum Brake ..... 41                  WHEEL CYLINDER ..... 41                  DRUM ..... 41</p>
---	--

D  
E

F

G

H

I

J

K

MA

M

# CHASSIS AND BODY MAINTENANCE

- Use Genuine Anaerobic Liquid Gasket or equivalent. Refer to [GI-42, "RECOMMENDED CHEMICAL PRODUCTS AND SEALANTS"](#).

**Drain plug : 25 - 34 N-m (2.5 - 3.5 kg-m, 18 - 25 ft-lb)**

## Checking Water Entry — For 4X4 Models With M/T

ELS000RM

Check water entry in the clutch housing by removing the sealing grommet, whenever driving in deep water or mud.

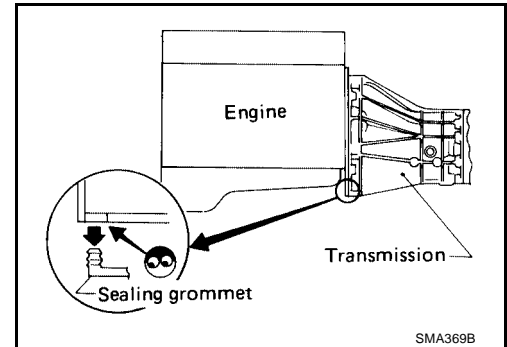

## Checking A/T Fluid

ELS000RN

1. Warm up engine.
2. Check for fluid leakage.
3. Before driving, fluid level can be checked at fluid temperatures of 30° to 50°C (86° to 122°F) using "COLD" range on dipstick.
  - a. Park vehicle on level surface and set parking brake.
  - b. Start engine and move selector lever through each gear position. Leave selector lever in "P" position.
  - c. Check fluid level with engine idling.
  - d. Remove dipstick and note reading. If level is at low side of either range, and fluid to the charging pipe.
  - e. Re-insert dipstick into charging pipe as far as it will go.
  - f. Remove dipstick and note reading. If reading is at low side of range, add fluid to the charging pipe.

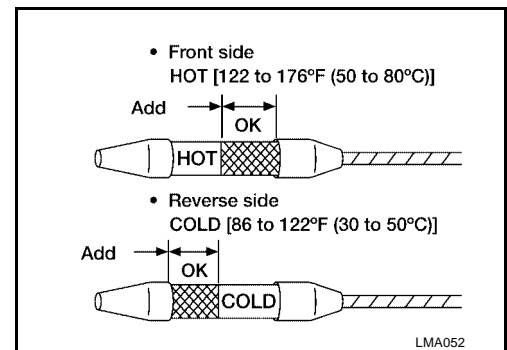

### Do not overfill.

4. Drive vehicle for approximately 5 minutes in urban areas.
5. Re-check fluid level at fluid temperatures of 50° to 80°C (122° to 176°F) using "HOT" range on dipstick.
6. Check fluid condition.
  - If fluid is very dark or smells burned, refer to AT section for checking operation of A/T. Flush cooling system after repair of A/T.
  - If A/T fluid contains frictional material (clutches, bands, etc.), replace radiator and flush cooler line using cleaning solvent and compressed air after repair of A/T. Refer to [CO-14, "RADIATOR"](#) (KA24DE), [CO-29, "RADIATOR"](#) (VG33E and VG33ER).

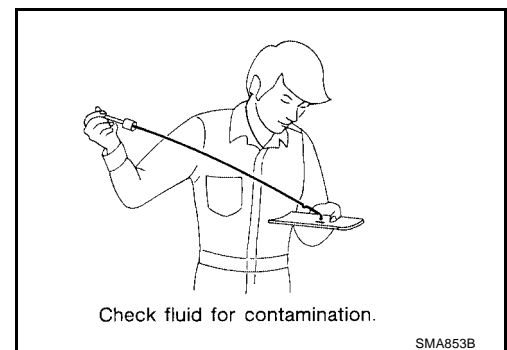

# GEAR COMPONENTS

[FS5W71C]

- b. Remove overdrive counter gear together with counter gear rear end bearing using a suitable puller.
- c. Remove reverse counter gear and reverse counter gear spacer.
- d. Remove snap rings from reverse idler shaft, then remove reverse idler gear, sub-gear, sub-gear spring, sub-gear bracket, steel ball, reverse idler thrust washer and reverse idler gear bearing.

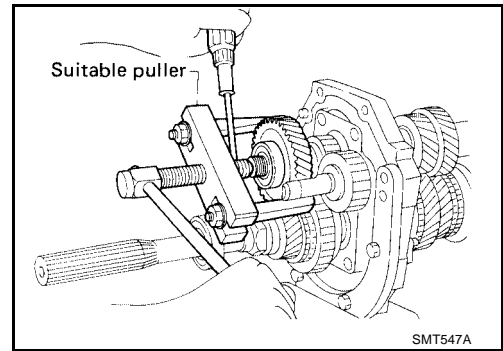

- e. Remove overdrive mainshaft bearing snap ring and pull out overdrive mainshaft bearing using Tool, then remove snap ring.

**Tool number : (J-26349-A), (J-25726-B)**

- f. Remove mainshaft lock nut.
- g. Remove speedometer drive gear and steel ball.
- h. Remove thrust washer, steel roller, roller bearing and washer.
- i. Remove overdrive main gear, needle bearing and overdrive baulk ring.
- j. Remove counter gear by tapping on rear end of counter gear.
- k. Press out overdrive gear bushing and overdrive & reverse synchronizer assembly.
- l. Remove reverse main gear and needle bearing.
- m. Press out reverse main gear bushing.

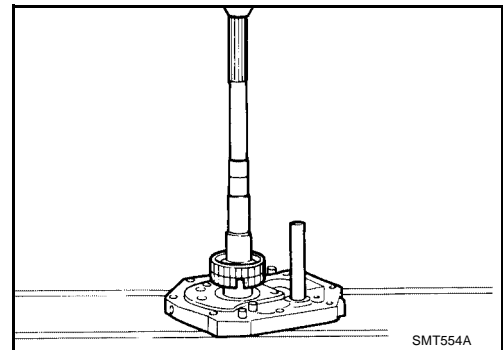

- n. Remove mainshaft by tapping on rear end of mainshaft.
- 7. Remove 1st gear thrust washer, steel ball, 1st main gear and needle bearing and 1st and 2nd synchronizer assembly.
  - Be careful not to lose steel ball.

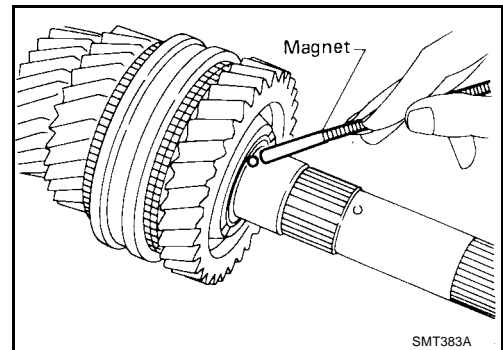

A  
B  
MT  
D  
E  
F  
G  
H  
I  
J  
K  
L  
M

# CASE COMPONENTS

[FS5R30A]

5. Remove front cover and gasket.

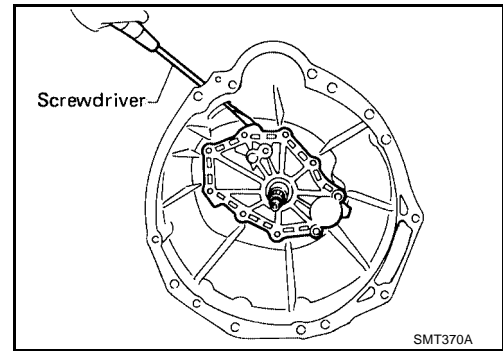

6. Remove stopper ring and main drive bearing snap ring.

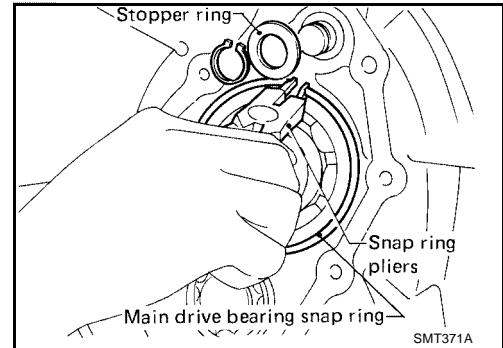

7. Remove transmission case by tapping lightly.

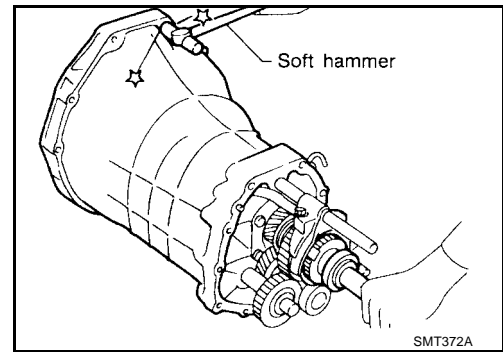

8. Remove counter gear front bearing shim and counter gear front thrust washer.  
9. Remove spacer from between main drive gear and mainshaft.  
10. Remove front cover oil seal using a screwdriver.

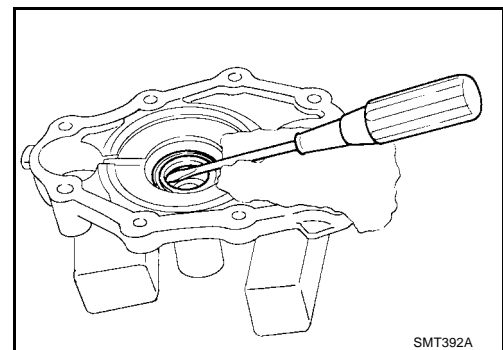

# PREPARATION

## PREPARATION

PF0:00002

### Special Service Tools

EJS002GE

The actual shapes of Kent-Moore tools may differ from those of special service tools illustrated here.

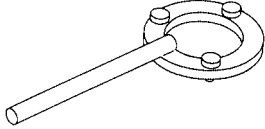
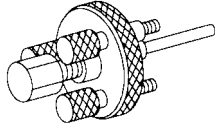
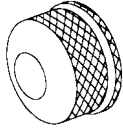
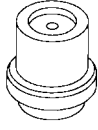
Tool number (Kent-Moore No.) Tool name	Description
KV99231260 (J-38874) Clutch disc wrench  <p style="text-align: center;">NT204</p>	Removing shaft nut and clutch disc
KV99232340 (J-38874) Clutch disc puller  <p style="text-align: center;">NT206</p>	Removing clutch disc
KV99234330 (J-39024) Pulley installer  <p style="text-align: center;">NT207</p>	Installing pulley
KV99233130 (J-39023) Pulley puller  <p style="text-align: center;">NT208</p>	Removing pulley

A  
B  
C  
D  
E  
F  
G  
H  
I  
K  
L  
M

MTC

# TROUBLE DIAGNOSIS

## 11. CHECK CIRCUIT CONTINUITY

1. Disconnect refrigerant pressure sensor harness connector E3.
2. Check circuit continuity between air control harness connector M95 terminal 2 (L/Y) and refrigerant pressure sensor connector E3 terminal 2 (L/Y).

**Continuity should exist.**

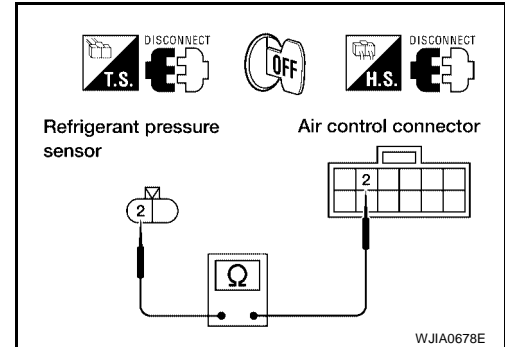

3. Also check circuit continuity between refrigerant pressure sensor connector E3 terminal 1 (G/R) and ECM connector F29 terminal 21 (G/R).

**Continuity should exist.**

OK or NG

- OK >> Check ECM. Refer to [EC-120](#) (KA24DE), [EC-692](#) (VG33E) or [EC-1293](#) (VG33ER).
- NG >> Repair harness or connector.

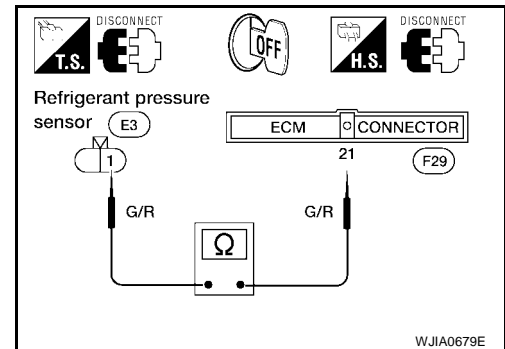

## 12. CHECK FUSES

Check 7.5A fuse (No. 29, located in the fuse and fusible link box) and 7.5A fuse (No. 35, located in the fuse and fusible link box). For fuse layout, refer to [PG-8, "POWER SUPPLY ROUTING"](#).

Are fuses OK?

- YES >> Check the following. If NG, repair harness or connectors.
- Harness for open between fuse and fusible link box and A/C relay
- NO >> GO TO 13

## 13. REPLACE FUSE

Replace fuse.

Does fuse blow when A/C is activated?

- Yes >> GO TO 14
- No >> **INSPECTION END**

## 14. CHECK A/C RELAY POWER SUPPLY CIRCUITS FOR SHORT

1. Disconnect battery cable and A/C relay.
2. Check for continuity on A/C relay connector E30 terminals 2 (G/OR), 5 (Y) to ground.

**Continuity should not exist.**

OK or NG

- OK >> Check the following.
- If NG, repair harness or connectors.
    - Harness connectors M95 and E30.
    - Harness for open or short between fuse and fusible link box and A/C relay, or A/C switch.
- NG >> Repair harness or connector.

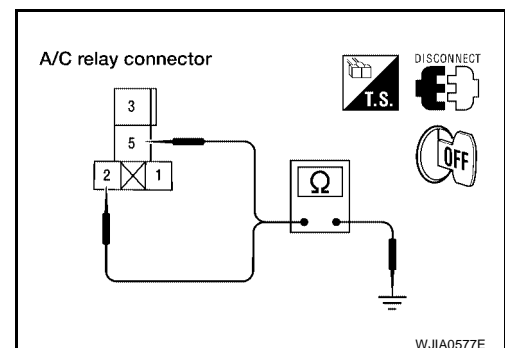

SECTION **PG**

**POWER SUPPLY, GROUND & CIRCUIT ELEMENTS**

**CONTENTS**

<b>PRECAUTIONS</b> .....	<b>3</b>	<b>GROUND</b> .....	<b>16</b>
Precautions for Supplemental Restraint System (SRS) "AIR BAG" and "SEAT BELT PRE-TENSIONER" .....	3	Ground Distribution .....	16
Wiring Diagrams and Trouble Diagnosis .....	3	MAIN HARNESS .....	16
<b>HARNESS CONNECTOR</b> .....	<b>4</b>	ENGINE ROOM HARNESS .....	18
Description .....	4	ENGINE NO. 2 HARNESS .....	22
HARNESS CONNECTOR (TAB-LOCKING TYPE) .....	4	GENERATOR HARNESS .....	23
HARNESS CONNECTOR (SLIDE-LOCKING TYPE) .....	5	ENGINE CONTROL HARNESS .....	24
HARNESS CONNECTOR (DIRECT-CONNECT SRS COMPONENT TYPE) .....	5	BODY HARNESS .....	27
<b>STANDARDIZED RELAY</b> .....	<b>6</b>	BODY NO. 2 HARNESS .....	28
Description .....	6	BACK DOOR NO. 2 HARNESS .....	29
NORMAL OPEN, NORMAL CLOSED AND MIXED TYPE RELAYS .....	6	<b>ELECTRICAL UNITS LOCATION</b> .....	<b>30</b>
TYPE OF STANDARDIZED RELAYS .....	6	Engine Compartment .....	30
<b>POWER SUPPLY ROUTING</b> .....	<b>8</b>	Passenger Compartment .....	31
Circuit Diagram .....	8	<b>HARNESS LAYOUT</b> .....	<b>33</b>
Wiring Diagram — POWER — .....	10	How to Read Harness Layout .....	33
BATTERY POWER SUPPLY — IGNITION SW. IN ANY POSITION .....	10	TO USE THE GRID REFERENCE .....	33
ACCESSORY POWER SUPPLY — IGNITION SW. IN ACC OR ON .....	12	CONNECTOR SYMBOL .....	33
IGNITION POWER SUPPLY — IGNITION SW. IN ON AND/OR START .....	13	Outline .....	34
Inspection .....	15	Main Harness .....	35
FUSE .....	15	Engine Room Harness .....	38
FUSIBLE LINK .....	15	KA24DE .....	38
CIRCUIT BREAKER .....	15	VG33E AND VG33ER .....	41
		Engine Control Harness .....	44
		KA24DE .....	44
		VG33E .....	46
		VG33ER .....	48
		Engine No. 2 Harness .....	50
		KA24DE .....	50
		VG33E .....	51
		VG33ER .....	52
		Body Harness .....	53
		Body No. 2 and Chassis Harness .....	54
		Room Lamp Harness .....	55
		Front Door Harness .....	55
		Rear Door Harness .....	56
		Back Door Harness .....	58
		Wiring Diagram Codes (Cell Codes) .....	59
		<b>SUPER MULTIPLE JUNCTION (SMJ)</b> .....	<b>62</b>
		Installation .....	62
		Terminal Arrangement .....	63

A  
B  
C  
D  
E  
F  
G  
H  
I  
J  
L  
M

**PG**

# HARNES LAYOUT

E1	(M2)	W/12	: To (RT)	A3	(M49)	B/1	: Parking brake switch	E5	(M88)	SB/8	: To (B3)
A1	(M4)	L/2	: ASCD clutch switch (with M/T)	C3	(M50)	W/6	: Audio unit	B2	(M89)	W/4	: Rear wiper switch
A1	(M5)	L/2	: Clutch interlock switch (with M/T)	D1	(M51)	W/10	: Audio unit	E3	(M91)	W/8	: To (E103)
A3	(M6)	B/5	: Vehicle security relay (with vehicle security system)	D3	(M52)	W/3	: Cigarette lighter socket	E5	(M92)	GY/6	: To (E12)
B2	(M7)	BR/12	: To (E53)	D3	(M53)	W/8	: Hazard switch	C2	(M95)	B/12	: Air control
A2	(M8)	W/12	: To (D2)	F5	(M54)	W/2	: To (M171)	D1	(M96)	B/6	: Intake door motor
A2	(M9)	W/12	: To (D1)	C4	(M57)	W/6	: Fan switch	C2	(M110)	W/24	: Smart entrance control unit
C1	(M11)	W/8	: Warning chime unit (without power door locks)	E2	(M58)	W/16	: To (F28) (except with KA24DE engine)	C1	(M111)	GY/24	: Smart entrance control unit
A3	(M12)	W/2	: Circuit breaker (with power door locks)	E2	(M59)	W/16	: To (F27)	B2	(M112)	GY/16	: Smart entrance control unit
B3	(M13)	L/4	: Power window relay (with power windows)	D2	(M60)	W/2	: Intake sensor	E4	(M113)	Y/12	: Air bag diagnosis sensor unit
B4	(M14)	-	: Body ground	D2	(M61)	BR/4	: Fan resistor	E4	(M114)	Y/28	: Air bag diagnosis sensor unit
C4	(M19)	W/3	: Seat belt buckle switch LH	D1	(M62)	W/2	: Blower motor	D2	(M117)	Y/4	: Passenger air bag module
D5	(M21)	GY/4	: Heated oxygen sensor 2 (with KA24DE engine)	E2	(M63)	W/12	: To (D10)	C3	(M118)	W/16	: Audio unit
B3	(M26)	W/16	: Fuse block (J/B)	E2	(M64)	W/2	: To (D102)	A3	(M119)	BR/24	: ASCD control unit
B3	(M27)	W/10	: Fuse block (J/B)	E3	(M65)	SMJ	: To (E43)	B1	(M128)	B/5	: ASCD relay
B4	(M28)	W/3	: Illumination control switch	E3	(M66)	W/4	: To (E44)	E4	(M131)	W/3	: Seat belt buckle switch RH
C4	(M30)	W/4	: Security indicator lamp (with vehicle security system)	E3	(M67)	W/16	: To (E101)	D3	(M132)	W/12	: Audio amplifier
B4	(M31)	W/3	: Fuse block (J/B)	E2	(M68)	-	: Body ground	E3	(M133)	W/12	: Audio amplifier
A3	(M32)	W/16	: Data link connector	F4	(M69)	B/6	: Yaw rate/side G-sensor	E1	(M134)	BR/2	: Pillar tweeter RH
D4	(M35)	W/6	: A/T device (with A/T)	A2	(M76)	B/5	: ATP relay (with A/T)	B3	(M137)	Y/4	: To (E88)
C3	(M37)	W/2	: Key switch	A2	(M77)	W/24	: TCM (with A/T)	A1	(M138)	BR/2	: Pillar tweeter LH
B2	(M38)	W/24	: Combination meter	A2	(M78)	GY/24	: TCM (with A/T)	C3	(M139)	Y/6	: Spiral cable
B2	(M39)	BR/24	: Combination meter	B1	(M79)	GY/3	: Diode-2 (with A/T)	C3	(M140)	GY/8	: Spiral cable
B1	(M44)	GY/2	: Diode-1	E2	(M81)	W/20	: To (F36) (with KA24DE engine)	D1	(M141)	B/2	: Diode-3
B1	(M45)	B/3	: Combination flasher unit	E2	(M81)	W/24	: To (F36) (with VG33E and VG33ER engine)	C1	(M143)	W/16	: Low tire pressure warning control unit
C1	(M46)	L/4	: Fuel pump relay	D4	(M82)	W/24	: To (E74) (with VG33E and VG33ER engine)	A3	(M144)	W/2	: Low tire pressure warning check connector
B1	(M47)	B/2	: Stop lamp switch	D4	(M83)	W/12	: To (E102)	C3	(M145)	B/7	: Steering angle sensor
B1	(M48)	L/2	: ASCD brake switch (A/T shift lock brake switch)	A3	(M84)	L/4	: Rear window defogger relay	B4	(M146)	GY/6	: VDC off switch (with VDC)
				C1	(M85)	W/4	: Rear window defogger timer	B2	(M147)	W/16	: CAN-LAN converter
				D5	(M86)	GY/10	: To (B1)	C1	(M151)	BR/6	: Low tire pressure warning relay
				D5	(M87)	B/8	: To (E2)				

WKIA2057E

# PROPELLER SHAFT ASSEMBLY

PFP:37000

EDS000NF

## PROPELLER SHAFT ASSEMBLY

### Components FRONT PROPELLER SHAFT

SEC. 370  
Model 2F1310

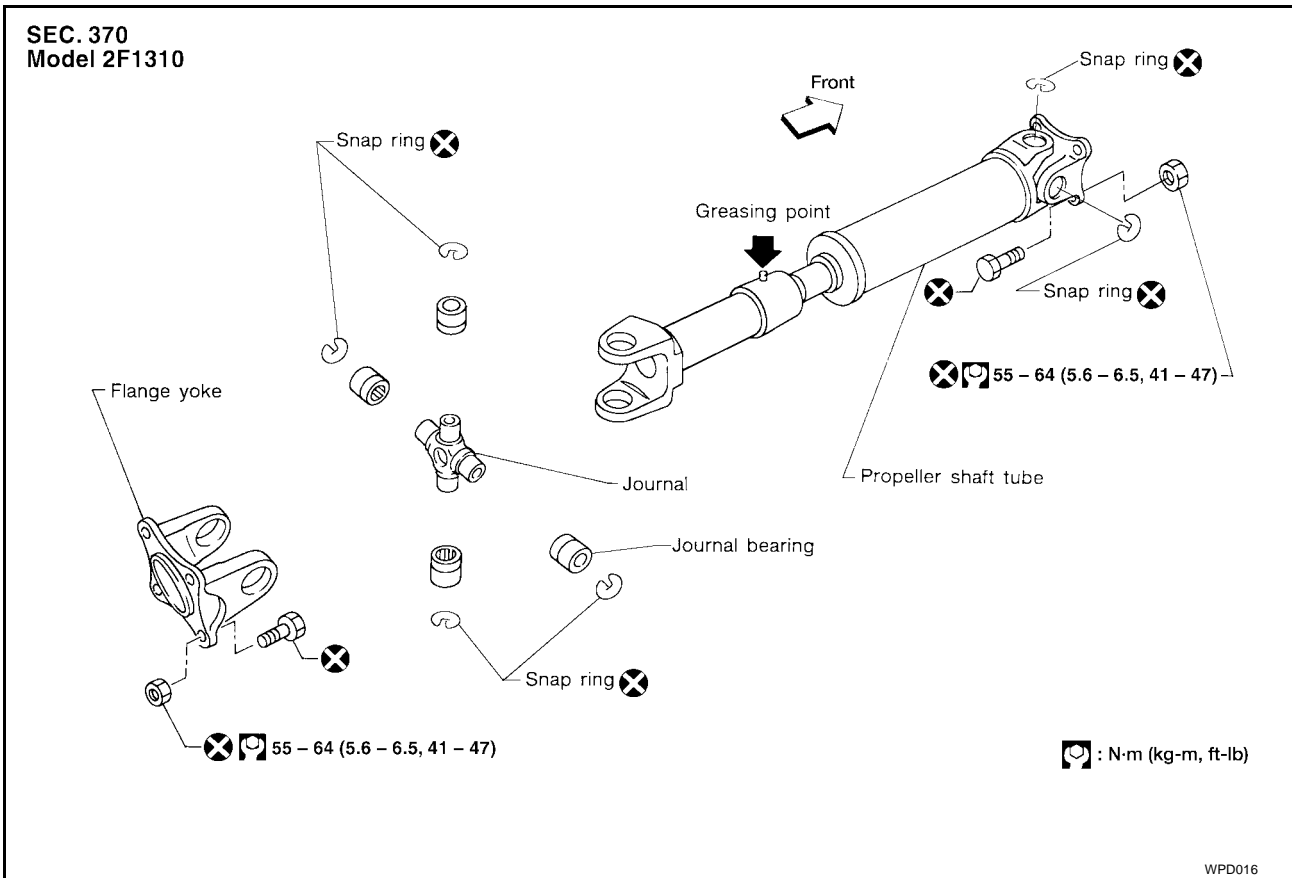

A  
B  
C  
PR  
E  
F  
G  
H  
I  
J  
K  
L  
M

# PRECAUTIONS

## PRECAUTIONS

PFP:00001

### Precautions

EDS000PV

- When installing rubber parts, final tightening must be carried out under unladen condition\* with tires on ground.  
\*: Fuel, radiator coolant and engine oil full. Spare tire, jack, hand tools and mats in designated positions.
- Use flare nut wrench when removing and installing brake tubes.
- After installing removed suspension parts, check wheel alignment and adjust if necessary.
- Always torque brake lines when installing.

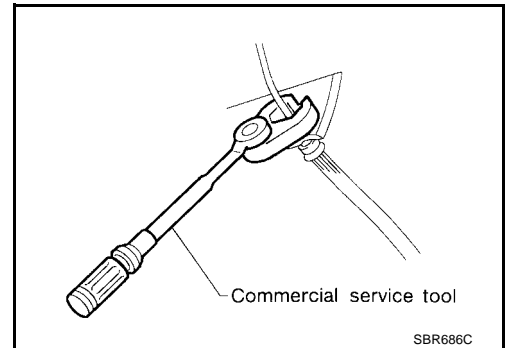

# REAR COVER GASKET

[C200]

## REAR COVER GASKET

PF3:38320

EDS000TN

### Removal and Installation

1. Drain gear oil. Refer to [MA-39, "Changing Differential Gear Oil"](#) .
2. Remove rear cover and rear cover gasket.
3. Install new rear cover gasket and rear cover.
4. Tighten rear cover bolts.

**Rear cover bolts** : 44 - 54 N-m (4.5 - 5.5 kg-m,  
33 - 39 ft-lb)

5. Fill final drive with recommended gear oil. Refer to [MA-12, "RECOMMENDED FLUIDS AND LUBRICANTS"](#) .

A

B

C

RFD

E

F

G

H

I

J

K

L

M

# REAR FINAL DRIVE ASSEMBLY

[H233B]

## DISASSEMBLY OF DIFFERENTIAL CASE (NON LSD)

1. Remove lock pin and remove the side gears, pinion mate gears and pinion mate shaft.
2. Remove side bearing inner cones.

**Tool number A: ST33051001 (J-22888-20)**

**Tool number B: ST33061000 (J-8107-2)**

**CAUTION:**

To prevent damage to bearing, engage puller jaws in groove.

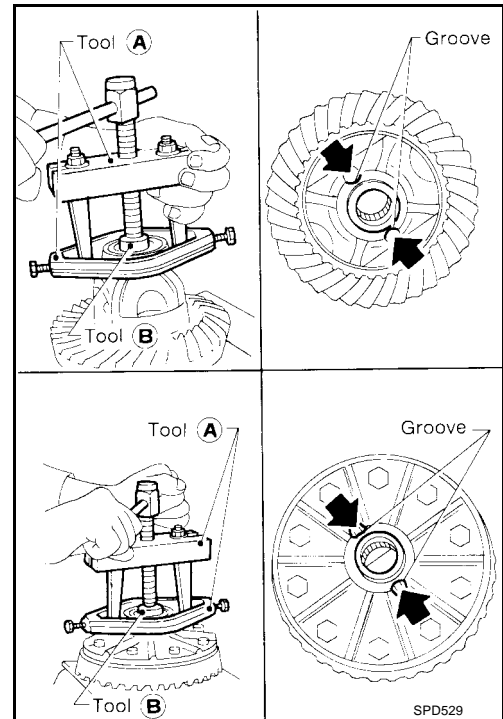

- Be careful not to confuse the left-hand and right-hand parts.
- Keep bearing and bearing race for each side together.

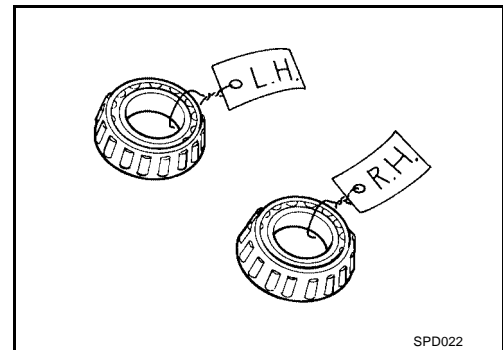

3. Loosen ring gear bolts in a crisscross pattern.
4. Tap ring gear off differential case with a soft hammer.
  - Tap evenly all around to keep ring gear from binding.

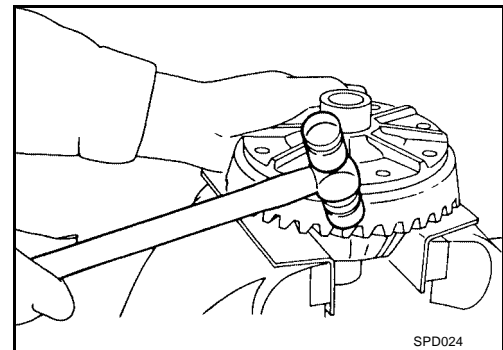

SECTION **SB**  
SEAT BELTS

A  
B  
C  
D  
E  
F  
G  
SB  
I  
J  
K  
L  
M

CONTENTS

<b>PRECAUTIONS</b> .....	<b>2</b>	<b>COLLISION DIAGNOSIS</b> .....	<b>6</b>
Precautions for Supplemental Restraint System (SRS) "AIR BAG" and "SEAT BELT PRE-TENSIONER" .....	2	Seat Belt Inspection .....	6
Precautions for Seat Belt Service .....	2	AFTER A COLLISION .....	6
AFTER A COLLISION .....	2	PRELIMINARY CHECKS .....	6
<b>FRONT SEAT BELT</b> .....	<b>3</b>	SEAT BELT RETRACTOR ON-VEHICLE CHECK .....	7
Removal and Installation .....	3	SEAT BELT RETRACTOR OFF-VEHICLE CHECK .....	8
<b>REAR SEAT BELT</b> .....	<b>5</b>	<b>TOP TETHER STRAP CHILD RESTRAINT</b> .....	<b>9</b>
Removal and Installation .....	5	Removal and Installation .....	9

# CHARGING SYSTEM

VG33E AND VG33ER MODELS

SC-CHARGE-02

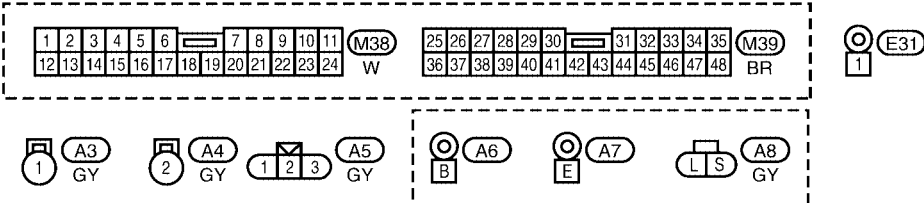
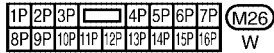
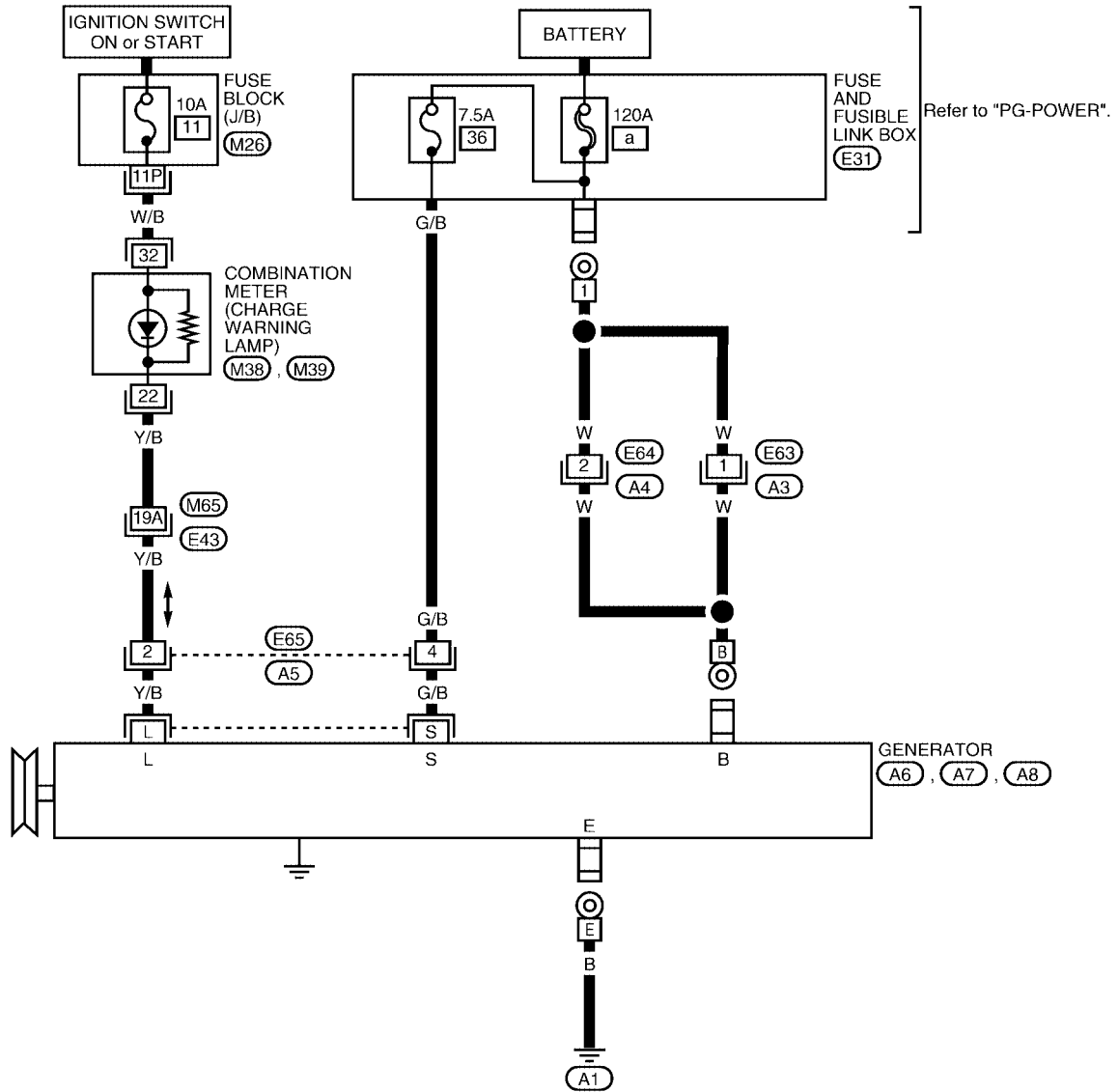

REFER TO THE FOLLOWING.  
 (E43) - SUPER MULTIPLE JUNCTION (SMJ)

## TROUBLE DIAGNOSIS

Diagnostic item	Explanation	Repair order <b>“Recheck SRS at each replacement.”</b>
PRE-TEN FRONT LH [OPEN] [B1086]	● Front LH seat belt pre-tensioner circuit is open.	1. Visually check the wiring harness connections. 2. Replace the harness if it has visible damage. 3. Replace driver seat belt. (Before disposing, the front LH seat belt pre-tensioner must be activated.) 4. Replace the air bag diagnosis sensor unit. 5. Replace the related harness.
PRE-TEN FRONT LH [VB-SHORT] [B1087]	● Front LH seat belt pre-tensioner circuit is shorted to a power supply circuit.	
PRE-TEN FRONT LH [GND-SHORT] [B1088]	● Front LH seat belt pre-tensioner circuit is shorted to ground.	
PRE-TEN FRONT LH [SHORT] [B1089]	● Front LH seat belt pre-tensioner circuit is shorted between lines.	
PRE-TEN FRONT RH [OPEN] [B1081]	● Front RH seat belt pre-tensioner circuit is open.	1. Visually check the wiring harness connections. 2. Replace the harness if it has visible damage. 3. Replace passenger seat belt. (Before disposing, the front RH seat belt pre-tensioner must be activated.) 4. Replace the air bag diagnosis sensor unit. 5. Replace the related harness.
PRE-TEN FRONT RH [VB-SHORT] [B1082]	● Front RH seat belt pre-tensioner circuit is shorted to a power supply circuit.	
PRE-TEN FRONT RH [GND-SHORT] [B1083]	● The circuit for front RH seat belt pre-tensioner is shorted to ground.	
PRE-TEN FRONT RH [SHORT] [B1084]	● Front RH seat belt pre-tensioner circuit is shorted between lines.	
CRASH ZONE SEN [UNIT FAIL] [B1033] or [B1034] CRASH ZONE SEN [COMM FAIL] [B1035]	● Crash zone sensor	1. Visually check the wiring harness connection. 2. Replace the harness if it has visible damage. 3. Replace the crash zone sensor. 4. Replace the diagnosis sensor unit. 5. Replace the related harness.
CURTAIN MODULE LH [OPEN] [B1150]	● LH side curtain air bag module circuit is open.	
CURTAIN MODULE LH [VB-SHORT] [B1151]	● LH side curtain air bag module circuit is shorted to a power supply circuits.	
CURTAIN MODULE LH [GND-SHORT] [B1152]	● LH side curtain air bag module circuit is shorted to ground.	
CURTAIN MODULE LH [SHORT] [B1153]	● LH side curtain air bag module circuit is shorted between lines.	
SATELLITE SENS RH [UNIT FAIL] [B1113] or [B1114] SATELLITE SENS RH [COMM FAIL] [B1115]	● RH side air bag (satellite) sensor.	1. Visually check the wiring harness connection. 2. Replace the harness if it has visible damage. 3. Replace the RH side air bag (satellite) sensor. 4. Replace the diagnosis sensor unit. 5. Replace the related harness.

A

B

C

D

E

F

G

SRS

I

J

K

L

M

CLICK HERE TO **DOWNLOAD** THE COMPLETE MANUAL

- Thank you very much for reading the preview of the manual.
- You can download the complete manual from: [www.heydownloads.com](http://www.heydownloads.com) by clicking the link below



- Please note: If there is no response to CLICKING the link, please download this PDF first and then click on it.

CLICK HERE TO **DOWNLOAD** THE COMPLETE MANUAL