

Edition: May 2003
 Revision: February 2004
 Publication No. SM4E-1Z33U4

NISSAN
350Z
MODEL Z33 SERIES

QUICK REFERENCE INDEX

A GENERAL INFORMATION	GI General Information	
B ENGINE	EM Engine Mechanical	
	LU Engine Lubrication System	
	CO Engine Cooling System	
	EC Engine Control System	
	FL Fuel System	
	EX Exhaust System	
	ACC Accelerator Control System	
	CL Clutch	
C TRANSMISSION/ TRANSAXLE	MT Manual Transmission	
	AT Automatic Transmission	
	PR Propeller Shaft	
D DRIVELINE/AXLE	RFD Rear Final Drive	
	FAX Front Axle	
	RAX Rear Axle	
	FSU Front Suspension	
	RSU Rear Suspension	
E SUSPENSION	WT Road Wheels & Tires	
	BR Brake System	
	PB Parking Brake System	
F BRAKES	BRC Brake Control System	
	PS Power Steering System	
	SB Seat Belts	
G STEERING	SRS Supplemental Restraint System (SRS)	
H RESTRAINTS	BL Body, Lock & Security System	
	GW Glasses, Window System & Mirrors	
I BODY	RF Roof	
	EI Exterior & Interior	
	IP Instrument Panel	
	SE Seat	
	ATC Automatic Air Conditioner	
	J AIR CONDITIONER	SC Starting & Charging System
	K ELECTRICAL	LT Lighting System
DI Driver Information System		
WW Wiper, Washer & Horn		
BCS Body Control System		
LAN LAN System		
AV Audio, Visual, Navigation & Telephone System		
ACS Auto Cruise Control System		
PG Power Supply, Ground & Circuit Elements		
L MAINTENANCE		MA Maintenance
M INDEX		IDX Alphabetical Index

A
B
C
D
E
F
G
H
I
J
K
L
M

© 2004 NISSAN MOTOR CO., LTD.

All rights reserved. No part of this Service Manual may be reproduced or stored in a retrieval system, or transmitted in any form, or by any means, electronic, mechanical, recording or otherwise, without the prior written permission of Nissan Motor Company Ltd., Tokyo, Japan.

CLICK HERE TO **DOWNLOAD** THE COMPLETE MANUAL

- Thank you very much for reading the preview of the manual.
- You can download the complete manual from: www.heydownloads.com by clicking the link below



- Please note: If there is no response to CLICKING the link, please download this PDF first and then click on it.

CLICK HERE TO **DOWNLOAD** THE COMPLETE MANUAL

A/T FLUID

10. Tighten the level gauge bolt.

Level gauge bolt:

 : 5.1N·m (0.52 kg-m, 45 in-lb)

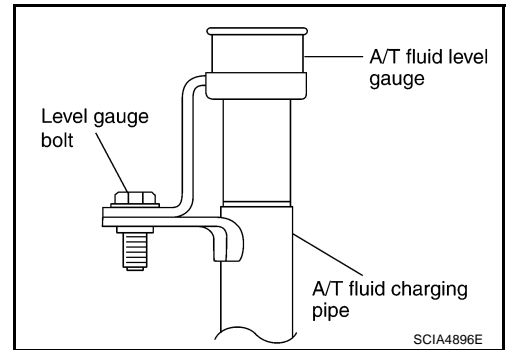

A/T Fluid Cooler Cleaning

ACS004LL

Whenever an automatic transmission is repaired, overhauled, or replaced, the A/T fluid cooler mounted in the radiator must be inspected and cleaned.

Metal debris and friction material, if present, can become trapped in the A/T fluid cooler. This debris can contaminate the newly serviced A/T or, in severe cases, can block or restrict the flow of A/T fluid. In either case, malfunction of the newly serviced A/T may result.

Debris, if present, may build up as A/T fluid enters the cooler inlet. It will be necessary to back flush the cooler through the cooler outlet in order to flush out any built up debris.

A/T FLUID COOLER CLEANING PROCEDURE

1. Position an oil pan under the automatic transmission's inlet and outlet cooler hoses.
2. Identify the inlet and outlet fluid cooler hoses.
3. Disconnect the fluid cooler inlet and outlet rubber hoses from the steel cooler tubes or bypass valve.

NOTE:

Replace the cooler hoses if rubber material from the hose remains on the tube fitting.

4. Allow any A/T fluid that remains in the cooler hoses to drain into the oil pan.

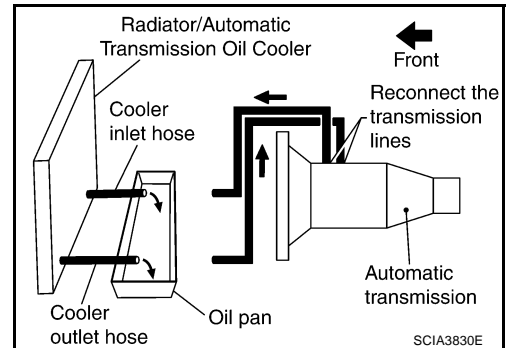

5. Insert the extension adapter hose of a can of Transmission Cooler Cleaner (Nissan P/N 999MP-AM006) into the cooler outlet hose.

CAUTION:

- Wear safety glasses and rubber gloves when spraying the Transmission Cooler Cleaner.
- Spray cooler cleaner only with adequate ventilation.
- Avoid contact with eyes and skin.
- Do not breath vapors or spray mist.

6. Hold the hose and can as high as possible and spray Transmission Cooler Cleaner in a continuous stream into the cooler outlet hose until fluid flows out of the cooler inlet hose for 5 seconds.

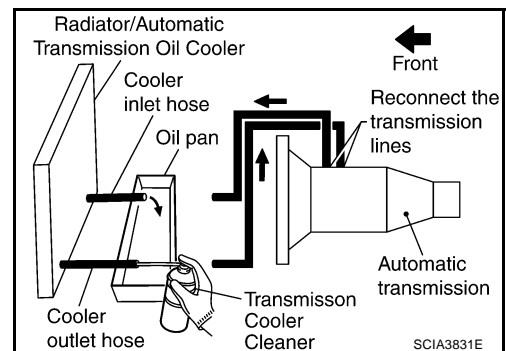

TROUBLE DIAGNOSIS

A/T Interlock

- If there is an A/T interlock judgment malfunction, the transmission is fixed in 2nd gear to make driving possible.

NOTE:

When the vehicle is driven fixed in 2nd gear a turbine revolution sensor malfunction is displayed, but this is not a turbine revolution sensor malfunction.

- When the coupling pattern below is detected, the fail-safe action corresponding to the pattern is executed.

A/T INTERLOCK COUPLING PATTERN TABLE

●: NG X: OK

Gear position		ATF pressure switch output					Fail-safe function	Clutch pressure output pattern after fail-safe function					
		SW3 (I/C)	SW6 (HLR/C)	SW5 (D/C)	SW1 (FR/B)	SW2 (LC/B)		I/C	HLR/C	D/C	FR/B	LC/B	L/U
A/T inter-lock coupling pattern	3rd	–	X	X	–	●	Held in 2nd gear	OFF	OFF	ON	OFF	OFF	OFF
	4th	–	X	X	–	●	Held in 2nd gear	OFF	OFF	ON	OFF	OFF	OFF
	5th	X	X	–	X	●	Held in 2nd gear	OFF	OFF	ON	OFF	OFF	OFF

A/T 1st Engine Braking

- When there is an A/T first gear engine brake judgment malfunction, the low coast brake solenoid is switched “OFF” to avoid the engine brake operation.

Line Pressure Solenoid

- The solenoid is switched “OFF” and the line pressure is set to the maximum hydraulic pressure to make driving possible.

Torque Converter Clutch Solenoid

- The solenoid is switched “OFF” to release the lock-up.

Low Coast Brake Solenoid

- When a (electrical or functional) malfunction occurs, in order to make driving possible, if the solenoid is “ON”, the transmission is held in 2nd gear; if the solenoid is “OFF”, the transmission is held in 4th gear. (engine brake is not applied in 1st and 2nd gear.)

Input Clutch Solenoid

- If a (electrical or functional) malfunction occurs with the solenoid either “ON” or “OFF”, the transmission is held in 4th gear to make driving possible.

Direct Clutch Solenoid

- If a (electrical or functional) malfunction occurs with the solenoid either “ON” or “OFF”, the transmission is held in 4th gear to make driving possible.

Front Brake Solenoid

- If a (electrical or functional) malfunction occurs with the solenoid “ON”, in order to make driving possible, the A/T is held in 5th gear; if the solenoid is OFF, 4th gear.

High and Low Reverse Clutch Solenoid

- If a (electrical or functional) malfunction occurs with the solenoid either “ON” or “OFF”, the transmission is held in 4th gear to make driving possible.

Turbine Revolution Sensor 1 or 2

- The control is the same as if there were no turbine revolution sensors, 5th gear and manual mode are prohibited.

TROUBLE DIAGNOSIS

No.	Items	Symptom	Condition	Diagnostic Item	Reference page
30	Slips/Will Not engage	No shock at all or the clutch slips when vehicle changes speed D4 → D5 or M4 → M5 .	ON vehicle	1. Fluid level and state	AT-50
				2. Vehicle speed sensor A/T and vehicle speed sensor MTR	AT-110, AT-141
				3. ATF pressure switch 1 and front brake solenoid valve	AT-174, AT-152
				4. ATF pressure switch 5 and direct clutch solenoid valve	AT-178, AT-156
				5. CAN communication line	AT-99
				6. Line pressure test	AT-51
				7. Control valve with TCM	AT-237
			OFF vehicle	8. Torque converter	AT-274
				9. Oil pump assembly	AT-289
				10. Front brake (brake band)	AT-274
				11. Input clutch	AT-294
				12. Gear system	AT-266
				13. High and low reverse clutch	AT-304
31	Slips/Will Not engage	When you press the accelerator pedal and shift speed D5 → D4 or M5 → M4 the engine idles or the transmission slips.	ON vehicle	1. Fluid level and state	AT-50
				2. Vehicle speed sensor A/T and vehicle speed sensor MTR	AT-110, AT-141
				3. ATF pressure switch 1 and front brake solenoid valve	AT-174, AT-152
				4. ATF pressure switch 5 and direct clutch solenoid valve	AT-178, AT-156
				5. CAN communication line	AT-99
				6. Line pressure test	AT-51
				7. Control valve with TCM	AT-237
			OFF vehicle	8. Torque converter	AT-274
				9. Oil pump assembly	AT-289
				10. Input clutch	AT-294
				11. Gear system	AT-266
				12. High and low reverse clutch	AT-304
				13. Direct clutch	AT-306

TROUBLE DIAGNOSIS

Judgement Self-diagnosis Code

If there is a malfunction, the lamp lights up for the time corresponding to the suspect circuit.

1	Revolution sensor
2	Direct clutch solenoid valve
3	Torque converter clutch solenoid valve
4	Line pressure solenoid valve
5	Input clutch solenoid valve
6	Front brake solenoid valve
7	Low coast brake solenoid valve
8	High and low reverse clutch solenoid valve
9	PNP switch
10	A/T fluid temperature sensor
11	Turbine revolution sensor
12	A/T interlock
13	A/T 1st engine braking
14	Start signal
15	Accelerator pedal position sensor
16	Engine speed signal
17	CAN

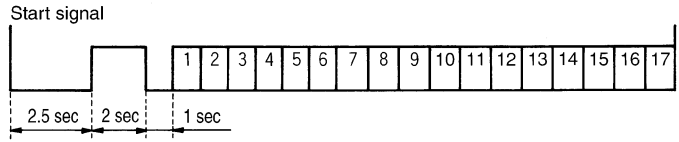

17-judgement flickers (OK)

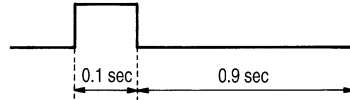

(NG)

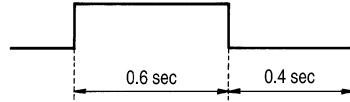

※ Solenoid valve is checked for open and short circuit, and malfunctions.

SCIA4758E

Erase Self-diagnosis

- In order to make it easier to find the cause of hard-to-duplicate malfunctions, malfunction information is stored into the control unit as necessary during use by the user. This memory is not erased no matter how many times the ignition switch is turned ON and OFF.
- However, this information is erased by turning ignition switch "OFF" after executing self-diagnostics or by erasing the memory using the CONSULT-II.

DTC P1701 TRANSMISSION CONTROL MODULE (POWER SUPPLY)

3. DETECT MALFUNCTIONING ITEM

Check the following items:

- Harness for short or open between battery and A/T assembly harness connector terminals 1, 2
- Harness for short or open between ignition switch and A/T assembly harness connector terminal 6
- 10A fuse (No.32, located in the fuse and fusible link block) and 10A fuse (No.71, located in the IPDM E/R)
- Ignition switch, Refer to [PG-4, "POWER SUPPLY ROUTING CIRCUIT"](#) .

OK or NG

- OK >> GO TO 4.
NG >> Repair or replace damaged parts.

4. CHECK TCM GROUND CIRCUIT

1. Turn ignition switch OFF.
2. Disconnect A/T assembly harness connector.
3. Check continuity between A/T assembly harness connector terminals and ground.

Continuity should exist.

If OK, check harness for short to ground and short to power.

OK or NG

- OK >> GO TO 5.
NG >> Repair open circuit or short to ground or short to power in harness or connectors.

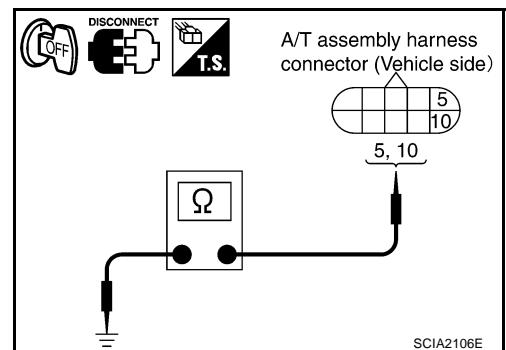

5. DETECT MALFUNCTIONING ITEM

Check the following items:

- The A/T assembly harness connector terminals for damage or loose connection with harness connector.

OK or NG

- OK >> GO TO 6.
NG >> Repair or replace damaged parts.

6. PERFORM SELF-DIAGNOSIS

Perform self-diagnosis. Refer to [AT-87, "SELF-DIAGNOSTIC RESULT MODE"](#) .

OK or NG

- OK >> **INSPECTION END**
NG-1 >> Self-diagnosis does not activate: GO TO 7.
NG-2 >> DTC is displayed: Check the malfunctioning system. Refer to [AT-87, "SELF-DIAGNOSTIC RESULT MODE"](#) .

DTC P1759 FRONT BRAKE SOLENOID VALVE FUNCTION

DTC P1759 FRONT BRAKE SOLENOID VALVE FUNCTION

PFPP:31940

Description

ACS003PM

- Front brake solenoid valve is controlled by the TCM in response to signals sent from the PNP switch, vehicle speed sensor and accelerator pedal position sensor (throttle position sensor). Gears will then be shifted to the optimum position.
- This is not only caused by electrical malfunction (circuits open or shorted) but also by mechanical malfunction such as control valve sticking, improper solenoid valve operation.

CONSULT-II Reference Value

ACS003PN

Item name	Condition	Display value (Approx.)
FR/B SOLENOID	Front brake engaged. Refer to AT-19 .	0.6 - 0.8 A
	Front brake disengaged. Refer to AT-19 .	0 - 0.05 A
ATF PRES SW 1	Front brake engaged. Refer to AT-19 .	ON
	Front brake disengaged. Refer to AT-19 .	OFF

On Board Diagnosis Logic

ACS003PO

- This is an OBD-II self-diagnostic item.
- Diagnostic trouble code "FR/B SOLENOID FNCT" with CONSULT-II or P1759 without CONSULT-II is detected under the following conditions.
 - When TCM detects that actual gear ratio is irregular, and relation between gear position and condition of ATF pressure switch 1 is irregular during depressing accelerator pedal. (Other than during shift change)
 - When TCM detects that relation between gear position and condition of ATF pressure switch 1 is irregular during releasing accelerator pedal. (Other than during shift change)

Possible Cause

ACS003PP

- Harness or connectors
(The solenoid and switch circuits are open or shorted.)
- Front brake solenoid valve
- ATF pressure switch 1

DTC Confirmation Procedure

ACS003PQ

CAUTION:

Always drive vehicle at a safe speed.

NOTE:

If "DTC Confirmation Procedure" has been previously performed, always turn ignition switch "OFF" and wait at least 10 seconds before performing the next test.

After the repair, perform the following procedure to confirm the malfunction is eliminated.

WITH CONSULT-II

1. Start engine.
2. Accelerate vehicle to maintain the following conditions.
ACCELE POS: 1.5/8 - 2.0/8
Selector lever: "D" position
Gear position: 3rd ⇒ 4th Gear (FR/B ON/OFF)
Driving location: Driving the vehicle uphill (increased engine load) will help maintain the driving conditions required for this test.
3. Perform step "2" again.
4. Turn ignition switch "OFF", then perform step "1" to "3" again.
5. Check "SELF-DIAG RESULTS" mode for "A/T" with CONSULT-II. If DTC (P1759) is detected, refer to [AT-155, "Diagnostic Procedure"](#) .
If DTC (P1757) is detected, go to [AT-153, "Diagnostic Procedure"](#) .
If DTC (P1841) is detected, go to [AT-175, "Diagnostic Procedure"](#) .

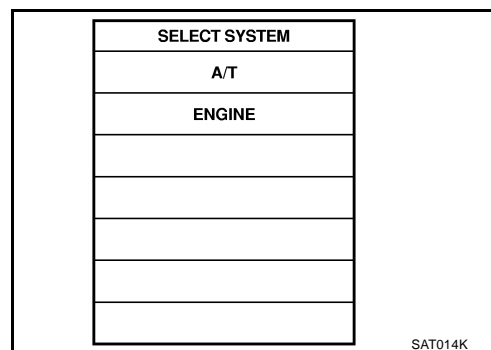

CLOSED THROTTLE POSITION AND WIDE OPEN THROTTLE POSITION CIRCUIT

CLOSED THROTTLE POSITION AND WIDE OPEN THROTTLE POSITION CIRCUIT

PFP:18002

CONSULT-II Reference Value

ACS008DB

Item name	Condition	Display value
CLSD THL POS	Released accelerator pedal.	ON
	Fully depressed accelerator pedal.	OFF
W/O THL POS	Fully depressed accelerator pedal.	ON
	Released accelerator pedal.	OFF

Diagnostic Procedure

ACS003R0

1. CHECK CAN COMMUNICATION LINE

Perform self-diagnosis. Refer to [AT-87, "SELF-DIAGNOSTIC RESULT MODE"](#) , [AT-97, "TCM SELF-DIAGNOSTIC PROCEDURE \(NO TOOLS\)"](#) .

Is a malfunction in the CAN communication indicated in the results?

- YES >> Check CAN communication line. Refer to [AT-99, "DTC U1000 CAN COMMUNICATION LINE"](#) .
 NO >> GO TO 2.

2. CHECK THROTTLE POSITION SIGNAL CIRCUIT

With CONSULT-II

- Turn ignition switch "ON". (Do not start engine.)
- Select "ECU INPUT SIGNALS" in "DATA MONITOR" mode for "A/T" with CONSULT-II.
- Depress accelerator pedal and read out the value of "CLSD THL POS" and "W/O THL POS".

Accelerator Pedal Operation	Monitor Item	
	CLSD THL POS	W/O THL POS
Released	ON	OFF
Fully depressed	OFF	ON

DATA MONITOR			
MONITOR		NO DTC	
ACCELE POSI	0.0/8		
THROTTLE POSI	0.0/8		
CLSD THL POS	ON		
W/O THL POS	OFF		
BRAKE SW	OFF		
		▽	
RECORD			
MODE	BACK	LIGHT	COPY

PCIA0070E

OK or NG

- OK >> **INSPECTION END**
 NG >> Check the following items. If NG, repair or replace damaged parts.
- Perform self-diagnosis for "ENGINE" with CONSULT-II. Refer to [EC-103, "CONSULT-II Function"](#) .
 - Open circuit or short to ground or short to power in harness or connectors.
 - Pin terminals for damage or loose connection with harness connector.

TROUBLE DIAGNOSIS FOR SYMPTOMS

7. CHECK A/T FLUID CONDITION

1. Remove oil pan. Refer to [AT-237, "Control Valve with TCM and A/T Fluid Temperature Sensor 2"](#) .
2. Check A/T fluid condition. Refer to [AT-50, "Fluid Condition Check"](#) .

OK or NG

- OK >> GO TO 8.
NG >> GO TO 11.

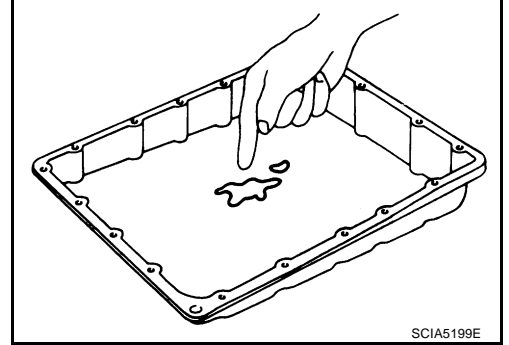

8. DETECT MALFUNCTIONING ITEM

- Check the malfunction items. If any items are damaged, repair or replace damaged parts. Refer to [AT-60, "Symptom Chart"](#) (Symptom No.13).

OK or NG

- OK >> GO TO 9.
NG >> Repair or replace damaged parts.

9. CHECK SYMPTOM

Check again. Refer to [AT-55, "Cruise Test - Part 1"](#) .

OK or NG

- OK >> **INSPECTION END**
NG >> GO TO 10.

10. CHECK TCM

1. Check TCM input/output signals. Refer to [AT-84, "TCM Input/Output Signal Reference Values"](#) .
2. If NG, recheck A/T assembly harness connector terminals for damage or loose connection with harness connector.

OK or NG

- OK >> **INSPECTION END**
NG >> Repair or replace damaged parts.

11. DETECT MALFUNCTIONING ITEM

- Check the malfunction items. If any items are damaged, repair or replace damaged parts. Refer to [AT-60, "Symptom Chart"](#) (Symptom No.13).

OK or NG

- OK >> GO TO 9.
NG >> Repair or replace damaged parts.

ON-VEHICLE SERVICE

5. Remove snap ring from A/T assembly harness connector.

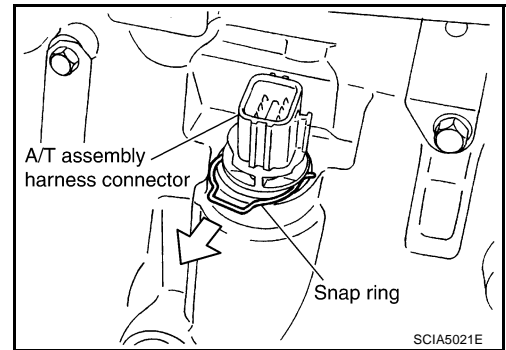

6. Push A/T assembly harness connector.

CAUTION:
Be careful not to damage connector.

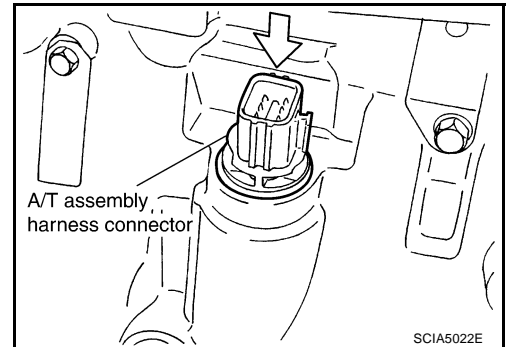

7. Remove oil pan and oil pan gasket.

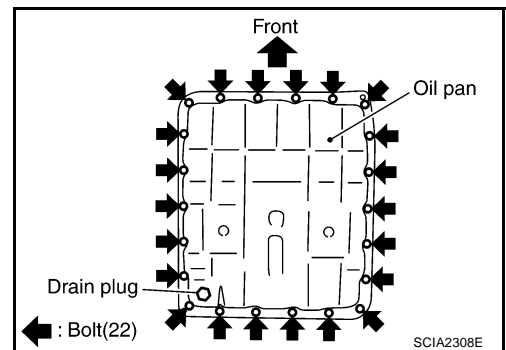

8. Check foreign materials in oil pan to help determine causes of malfunction. If the A/T fluid is very dark, smells burned, or contains foreign particles, the frictional material (clutches, band) may need replacement. A tacky film that will not wipe clean indicates varnish build up. Varnish can cause valves, servo, and clutches to stick and can inhibit pump pressure.

● If frictional material is detected, perform A/T fluid cooler cleaning. Refer to [AT-14, "A/T Fluid Cooler Cleaning"](#).

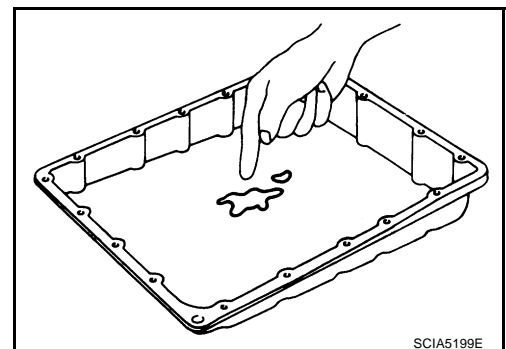

9. Remove magnets from oil pan.

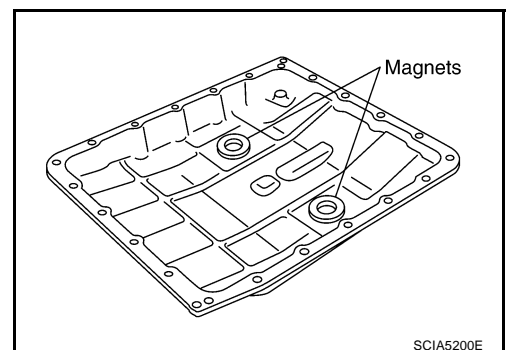

REPAIR FOR COMPONENT PARTS

ACS008CM

Front Carrier, Input Clutch, Rear Internal Gear COMPONENTS

SEC.314 .315

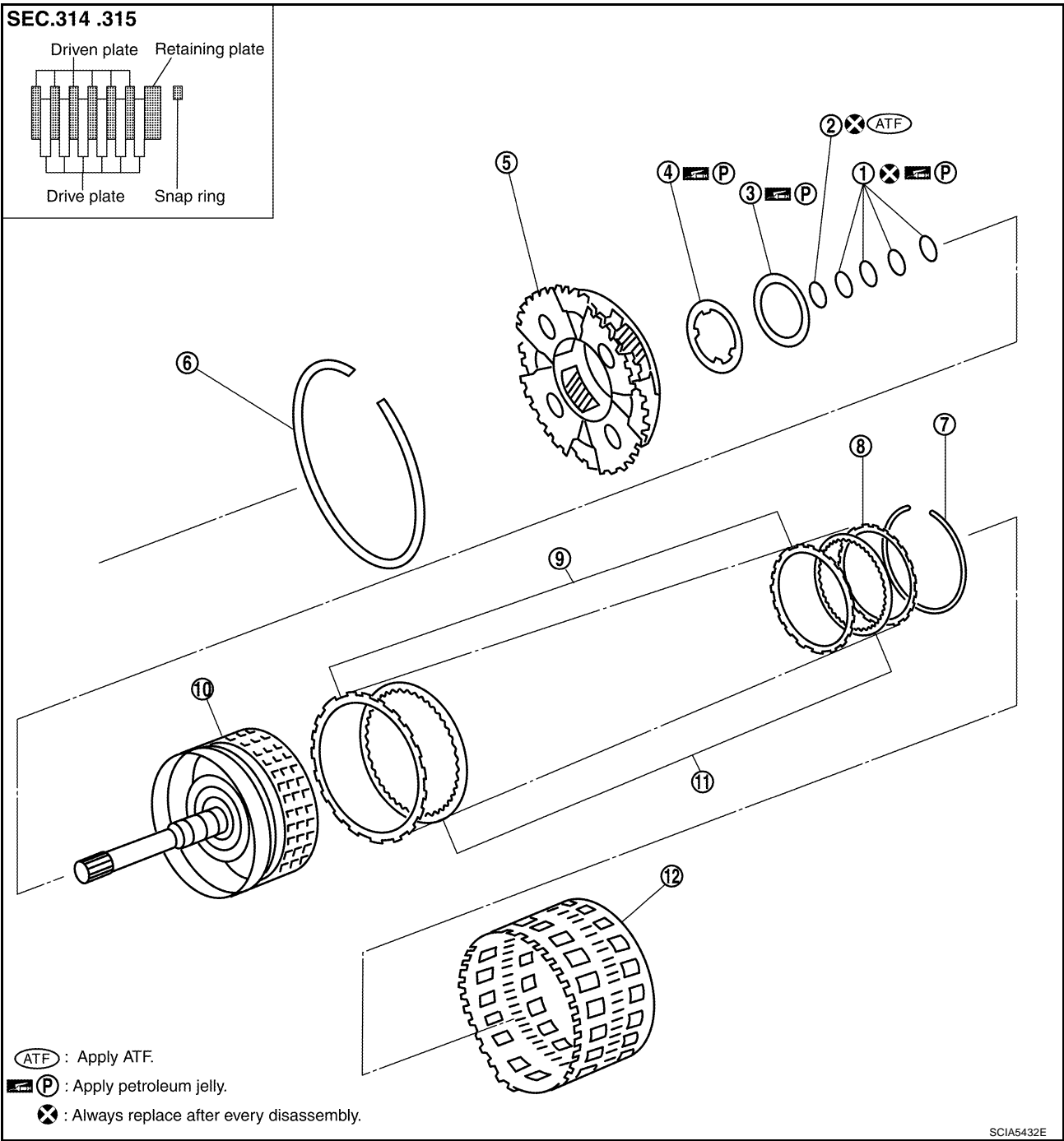
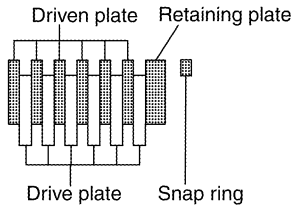

- : Apply ATF.
- : Apply petroleum jelly.
- : Always replace after every disassembly.

SCIA5432E

- | | | |
|-----------------------|---------------------------|------------------------|
| 1. Seal ring | 2. O-ring | 3. Needle bearing |
| 4. Bearing race | 5. Front carrier assembly | 6. Snap ring |
| 7. Snap ring | 8. Retaining plate | 9. Driven plate |
| 10. Input clutch drum | 11. Drive plate | 12. Rear internal gear |

ASSEMBLY

6. Install O-ring to input clutch assembly.

CAUTION:

- Do not reuse O-ring.
- Apply ATF to O-ring.

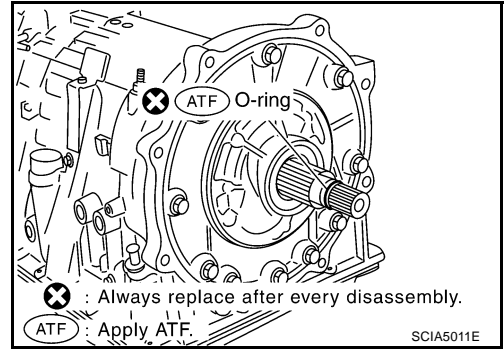

7. Install converter housing to transmission case.

CAUTION:

Do not reuse self-sealing bolt.

Converter housing mounting bolt:

⊗ : 52 N·m (5.3 kg·m, 38 ft·lb)

Self-sealing bolt:

⊗ : 61 N·m (6.2 kg·m, 45 ft·lb)

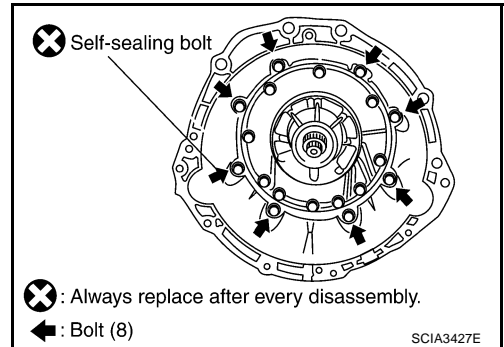

8. Make sure that brake band does not close turbine revolution sensor hole.

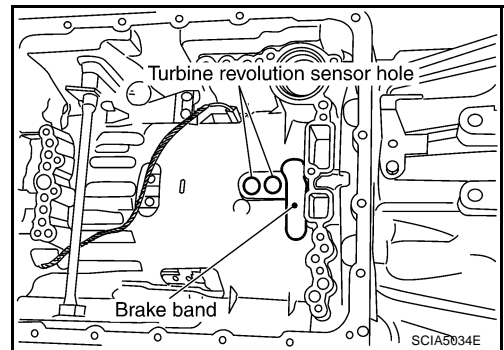

9. Install control valve with TCM.

- a. Connect TCM connector and park/neutral position switch connector.

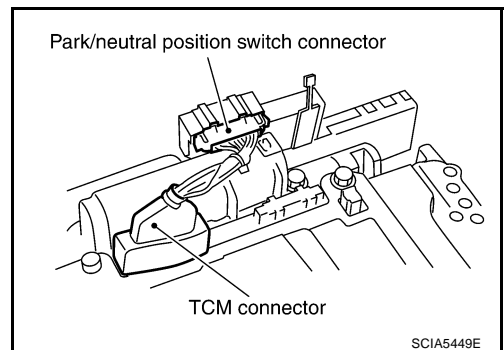

REFRIGERATION SYSTEM

V-6 Variable Displacement Compressor

AJS000MV

GENERAL INFORMATION

1. The V-6 variable compressor differs from previous units. The vent temperatures of the V-6 variable compressor do not drop too far below 5°C (41°F) when:
Evaporator intake air temperature is less than 20°C (68°F).
Engine is running at speeds less than 1,500 rpm.
This is because the V-6 compressor provides a means of “capacity” control.
2. The V-6 variable compressor provides refrigerant control under varying conditions. During cold winters, it may not produce high refrigerant pressure discharge (compared to previous units) when used with air conditioning systems.
3. A “clanking” sound may occasionally be heard during refrigerant charge. The sound indicates that the tilt angle of the wobble (swash) plate has changed and is not a malfunction.
4. For air conditioning systems with the V-6 compressor, the clutch remains engaged unless: the system main switch, fan switch or ignition switch is turned OFF. When ambient (outside) temperatures are low or when the amount of refrigerant is insufficient, the clutch is disengaged to protect the compressor.
5. A constant range of suction pressure is maintained when engine speed is greater than a certain value. It normally ranges from 147 to 177 kPa (1.5 to 1.8 kg/cm² , 21 to 26 psi) under varying conditions. In previous compressors, however, suction pressure was reduced with increases in engine speed.

TROUBLE DIAGNOSIS

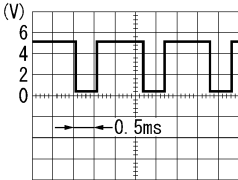
Terminal No.	Wire color	Item	Ignition switch	Condition	Voltage (V)
46	L/W	Power supply for IGN2	ACC or ON	-	Battery voltage
49	W/L	Sensor ground	ON	-	Approx. 0
50	LG	Sunload sensor	-	-	-
53	G	Blower fan motor control signal	ACC or ON	Fan speed: 1st	 <p style="text-align: right; font-size: small;">SJIA0116J</p>
54	Y/R	Power supply for each door motor	ON	-	Battery voltage
56	B/W	Rear window defogger feedback signal	ON	Rear window defogger: ON	Approx. 12
				Rear window defogger: OFF	Approx. 0
57	BR/W	Blower fan motor ON signal	ACC or ON	Fan: ON	Approx. 0
				Fan: OFF	Approx. 5

TROUBLE DIAGNOSIS

SYSTEM DESCRIPTION

Component Parts

Fan speed control system components are:

- Unified meter and A/C amp.
- A/C LAN system (PBR built-in mode door motor and air mix door motor)
- In-vehicle sensor
- Ambient sensor
- Sunload sensor
- Intake sensor

System Operation

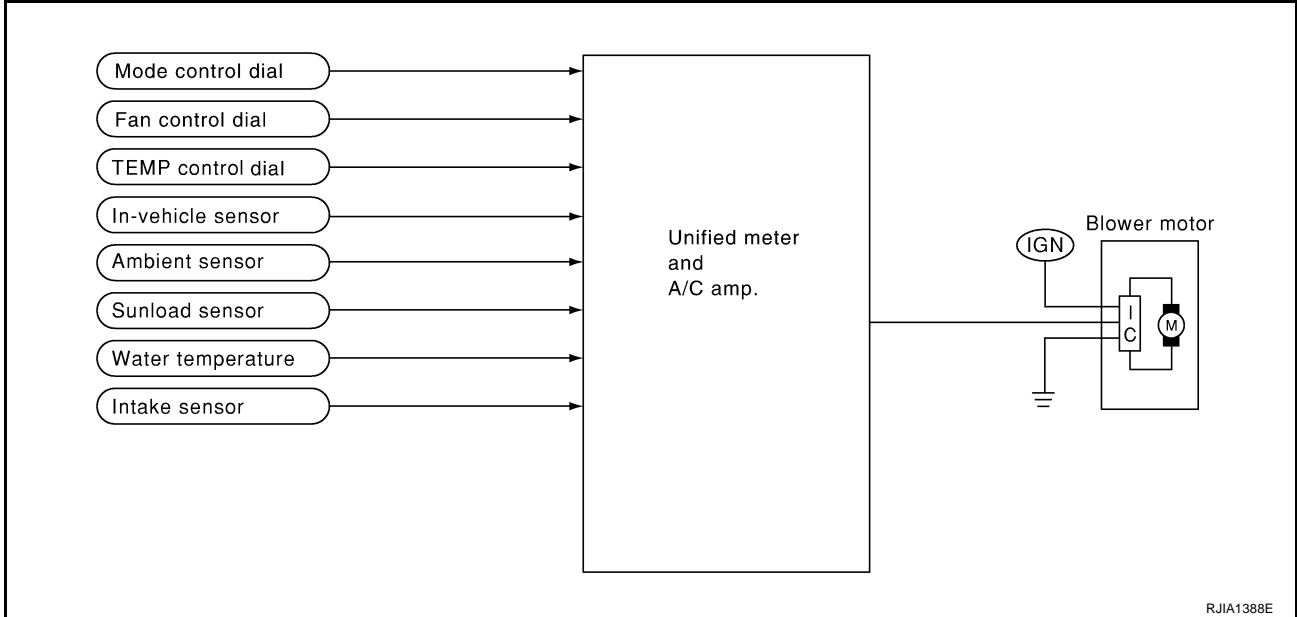

Automatic Mode

In the automatic mode, the blower motor speed is calculated by the unified meter and A/C amp. based on input from the PBR, in-vehicle sensor, sunload sensor, intake sensor and ambient sensor.

When the air flow is increased, the duty ratio of the blower fan motor's drive signal is changed at 8%/sec. to prevent a sudden increase in air flow.

In addition to manual air flow control and the usual automatic air flow control, starting air flow control, low water temperature starting control and high passenger compartment temperature starting control are available.

Starting Fan Speed Control

Start Up from COLD SOAK Condition (Automatic mode)

In a cold start up condition where the engine coolant temperature is below 56°C (133°F), the blower will not operate for a short period of time (up to 150 seconds). The exact start delay time varies depending on the ambient and engine coolant temperature.

In the most extreme case (very low ambient) the blower starting delay will be 150 seconds as described above. After this delay, the blower will operate at low speed until the engine coolant temperature rises above 56°C (133°F), at which time the blower speed will increase to the objective speed.

Start Up from Usual or HOT SOAK Condition (Automatic mode)

The blower will begin operation momentarily after the A/C switch is pushed. The blower speed will gradually rise to the objective speed over a time period of 3 seconds or less (actual time depends on the objective blower speed).

TROUBLE DIAGNOSIS

COMPONENT INSPECTION

Sunload Sensor

Measure voltage between unified meter and A/C amp. harness connector M50 terminal 50 (LG) and ground.
If NG, replace unified meter and A/C amp.

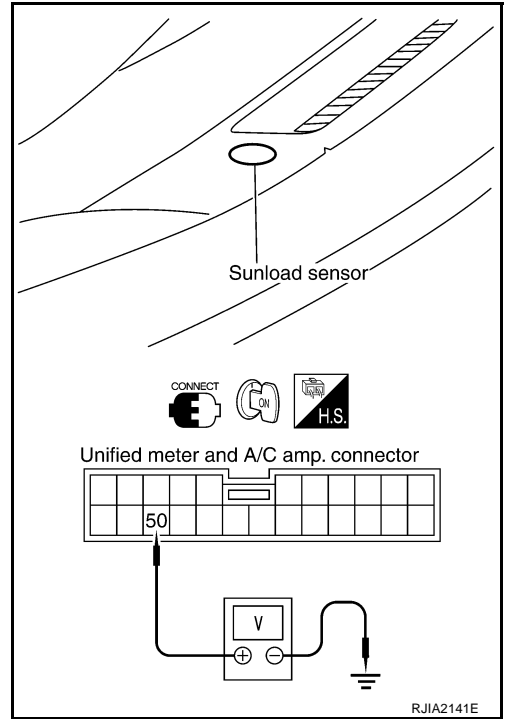

- When checking sunload sensor, select a place where sun shines directly on it.

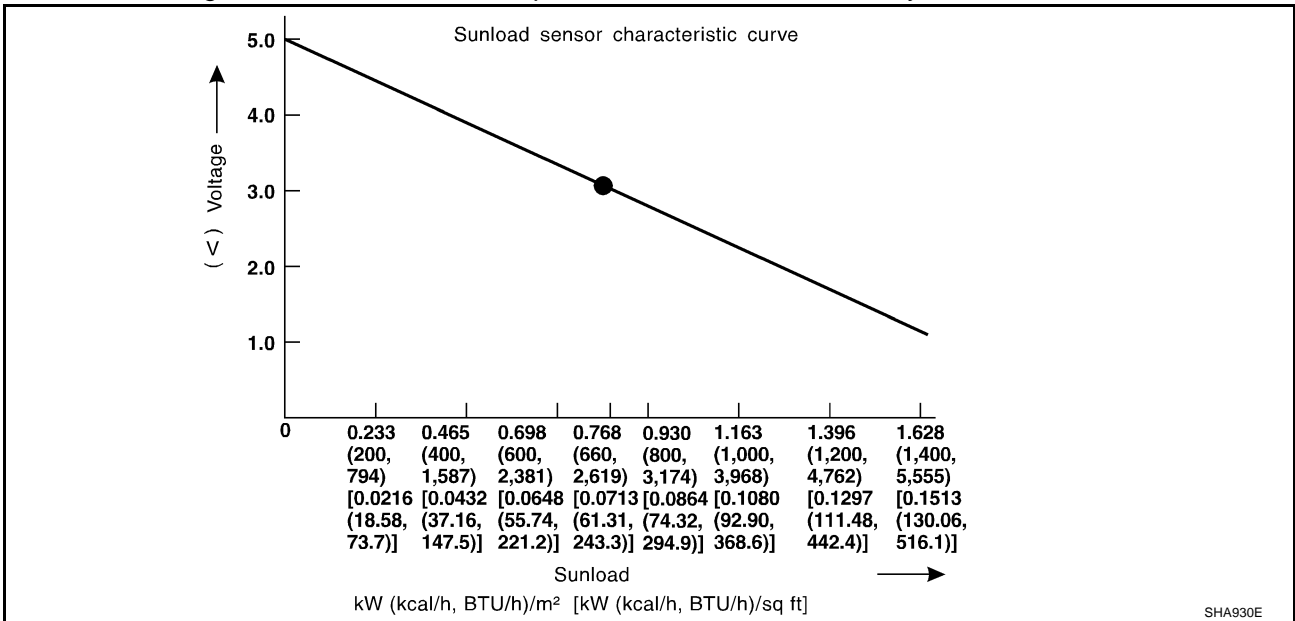

REFRIGERANT LINES

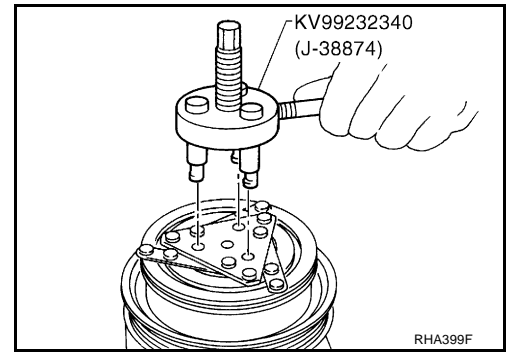

2. Remove the clutch disc using the clutch disc puller.

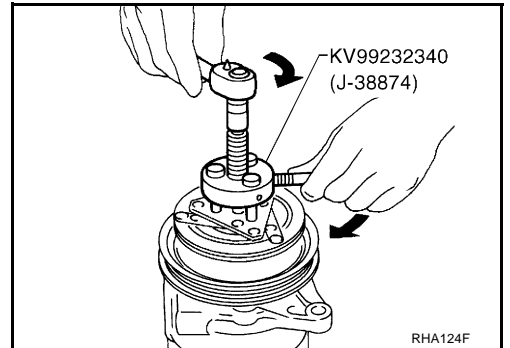

3. Remove the snap ring using external snap ring pliers.

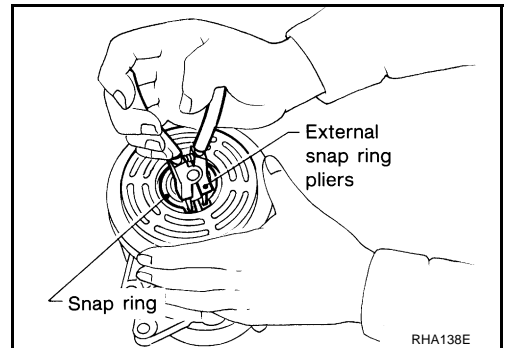

4. Position the center pulley puller on the end of the drive shaft, and remove the pulley assembly using any commercially available pulley puller.
To prevent the pulley groove from being deformed, the puller claws should be positioned into the edge of the pulley assembly.

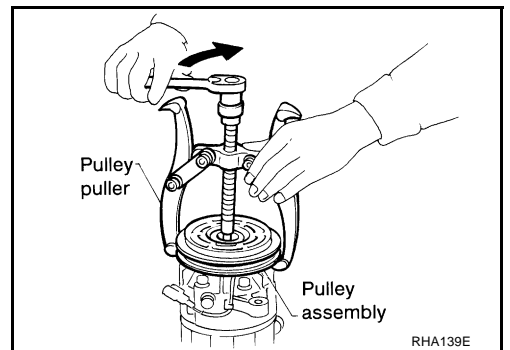

AUDIO

AV-AUDIO-02

WN : WITH NAVIGATION SYSTEM
 ON : WITHOUT NAVIGATION SYSTEM

*1 LG/R : ON *3 L/OR : ON
 BR : WN L : WN
 *2 B/Y : ON *4 B/P : ON
 B/R : WN P : WN

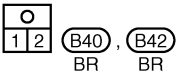
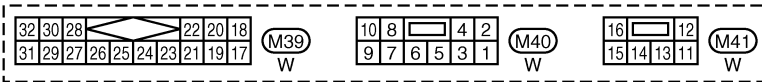
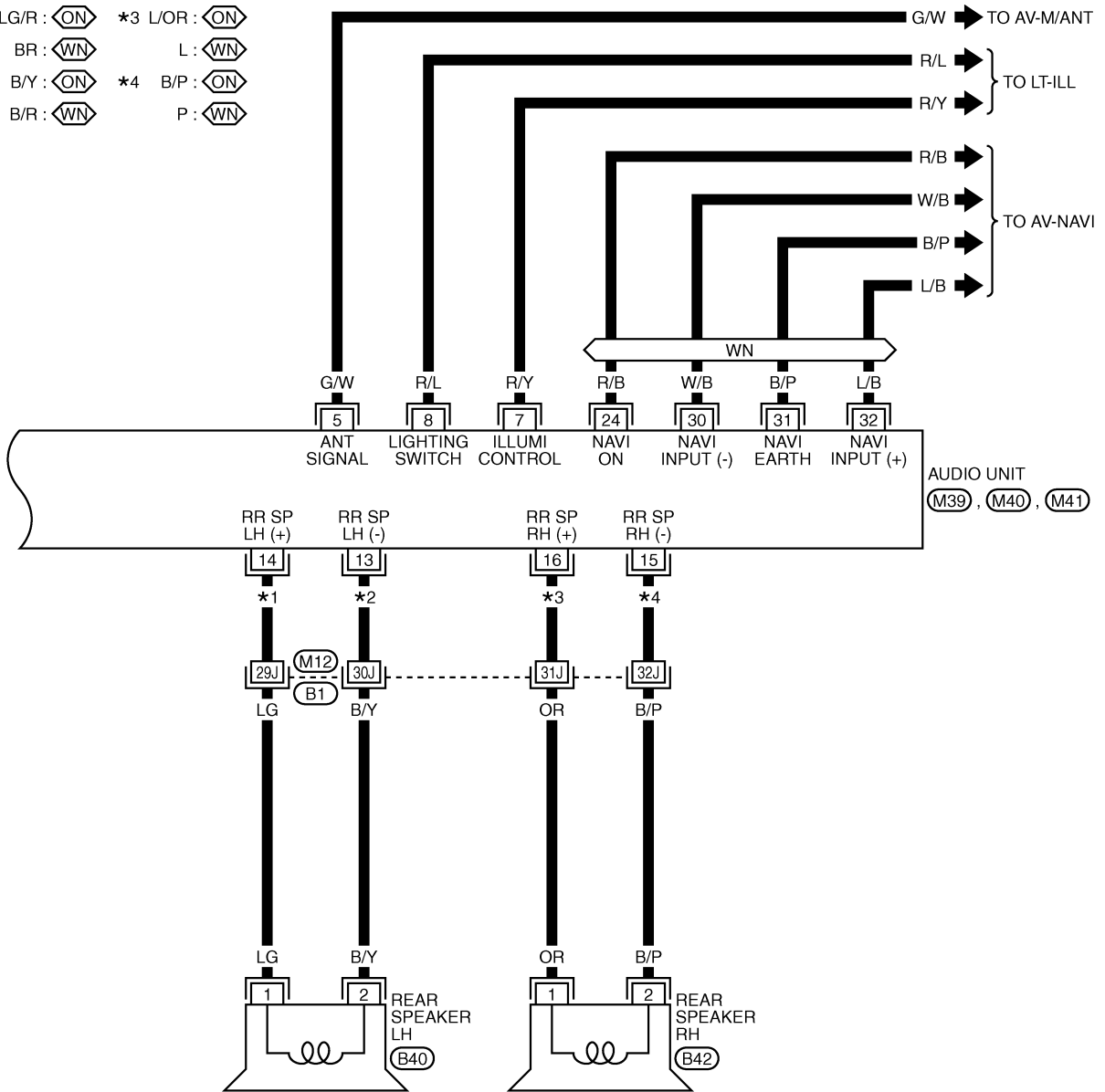

REFER TO THE FOLLOWING.
 B1 -SUPER MULTIPLE JUNCTION (SMJ)

NAVIGATION SYSTEM

PFP:25915

System Description

AKS00117

The navigation system periodically calculates the vehicle's current position according to the following three signals: Travel distance of the vehicle as determined by the vehicle speed sensor, turning angle of the vehicle as determined by the gyroscope (angular velocity sensor), and the direction of vehicle travel as determined by the GPS antenna (GPS information).

The current position of the vehicle is then identified by comparing the calculated vehicle position with map data read from the map DVD-ROM, which is stored in the DVD-ROM drive (map-matching), and indicated on the screen with a current-location mark.

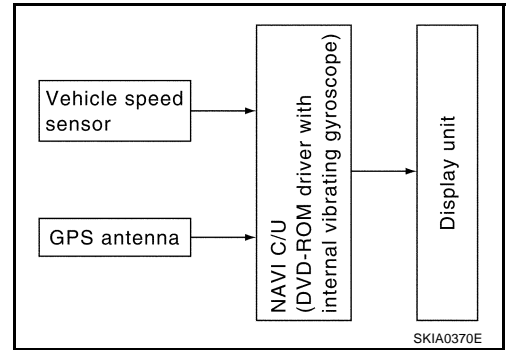

By comparing the vehicle position detection results found by the GPS and by map-matching, more accurate vehicle position data can be used.

The current vehicle position will be calculated by detecting the distance the vehicle moved from the previous calculation point and its direction.

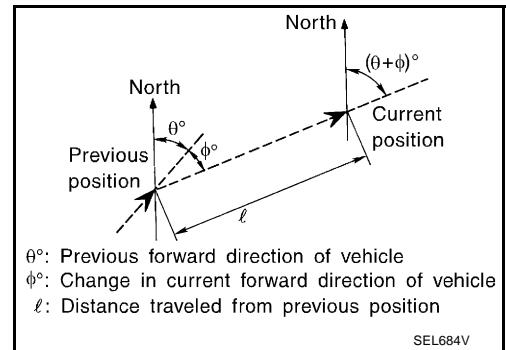

TRAVEL DISTANCE

Travel distance calculations are based on the vehicle speed sensor input signal. Therefore, the calculation may become incorrect as the tires wear down. To prevent this, an automatic distance fine adjustment function has been adopted.

TRAVEL DIRECTION

Change in the travel direction of the vehicle is calculated by a gyroscope (angular velocity sensor) and a GPS antenna (GPS information). As the gyroscope and GPS antenna have both merit and demerit, input signals from them are prioritized in each situation. However, this order of priority may change in accordance with more detailed travel conditions so that the travel direction is detected more accurately.

Type	Advantage	Disadvantage
Gyroscope (angular velocity sensor)	<ul style="list-style-type: none"> Can detect the vehicle's turning angle quite accurately. 	<ul style="list-style-type: none"> Direction errors may accumulate when the vehicle is driven for long distances without stopping.
GPS antenna (GPS information)	<ul style="list-style-type: none"> Can detect the vehicle's travel direction (North/South/East/West). 	<ul style="list-style-type: none"> Correct direction cannot be detected when the vehicle speed is low.

MAP-MATCHING

Map-matching is a function that repositions the vehicle on the road map when a new location is judged to be the most accurate. This is done by comparing the current vehicle position, calculated by the method described in the position detection principle, with the road map data around the vehicle, read from the map DVD-ROM stored in the DVD-ROM drive.

Therefore, the vehicle position may not be corrected after the vehicle is driven over a certain distance or time in which GPS information is hard to receive. In this case, the current-location mark on the display must be corrected manually.

CAUTION:

The road map data is based on data stored in the map DVD-ROM.

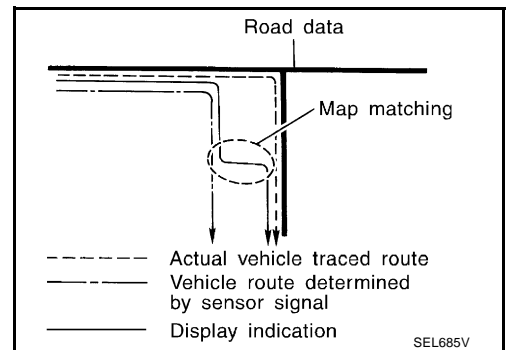

NAVIGATION SYSTEM

4. When "CONFIRMATION/ADJUSTMENT" is selected on the initial trouble diagnosis screen, the operation will enter the CONFIRMATION/ADJUSTMENT mode. In this mode, check and adjustment of each item will become possible.
5. Select each switch on "CONFIRMATION/ADJUSTMENT" screen to display the relevant diagnosis screen.

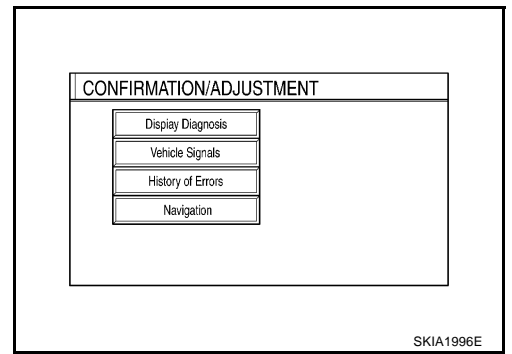

DISPLAY DIAGNOSIS

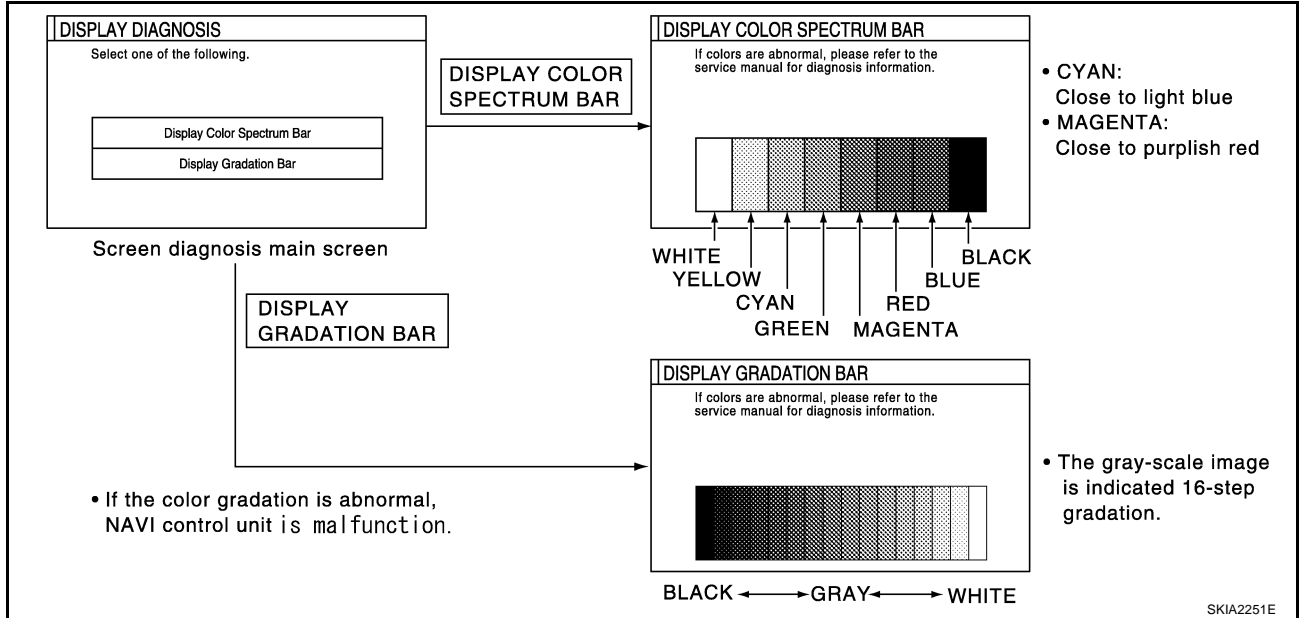

CAUTION:

When Display Color Spectrum Bar screen is completed after "PREV" switch is Pushed, the screen color changes once. This is normal.

- When RGB signal error occurred in the RGB system, tone of the color bar will change as follows.
 - R (red) signal error** : Screen looks bluish.
 - G (green) signal error** : Screen looks reddish.
 - B (blue) signal error** : Screen looks yellowish.
- When the color of the screen looks unusual, refer to [AV-83, "Color of RGB Image is Not Proper"](#) .

NAVIGATION SYSTEM

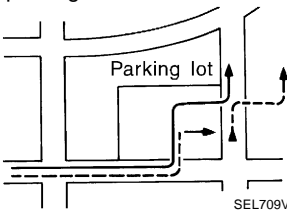
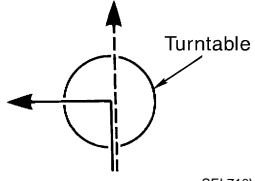
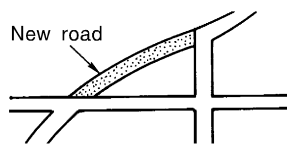
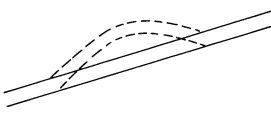
	Cause (condition) -:While driving ooo:Display	Driving condition	Remarks (correction, etc.)
Place	<p>In a parking lot</p>  <p style="text-align: right; font-size: small;">SEL709V</p>	<p>When driving in a parking lot, or other location where there are no roads on the map, matching may place the vehicle mark on a nearby road. When the vehicle returns to the road, the vehicle mark may have deviated from the correct location. When driving in circle or turning the steering wheel repeatedly, direction errors accumulate, and the vehicle mark may deviate from the correct location.</p>	<p>If after travelling about 10 km (6 miles) the correct location has not been restored, perform location correction and, if necessary, direction correction.</p>
	<p>Turn table</p>  <p style="text-align: right; font-size: small;">SEL710V</p>	<p>When the ignition switch is OFF, the navigation system cannot get the signal from the gyroscope (angular speed sensor). Therefore, the displayed direction may be wrong and the correct road may not be easily returned to after rotating the vehicle on a turntable with the ignition OFF.</p>	
	<p>Slippery roads</p>	<p>On snow, wet roads, gravel, or other roads where tires may slip easily, accumulated mileage errors may cause the vehicle mark to deviate from the correct road.</p>	
	<p>Slopes</p>	<p>When parking in sloped garages, when travelling on banked roads, or in other cases where the vehicle turns when tilted, an error in the turning angle will occur, and the vehicle mark may deviate from the road.</p>	
Map data	<p>Road not displayed on the map screen</p>  <p style="text-align: right; font-size: small;">SEL699V</p>	<p>When driving on new roads or other roads not displayed on the map screen, map matching does not function correctly and matches the location to a nearby road. When the vehicle returns to a road which is on the map, the vehicle mark may deviate from the correct road.</p>	
	<p>Different road pattern (Changed due to repair)</p>  <p style="text-align: right; font-size: small;">ELK0201D</p>	<p>If the road pattern stored in the map data and the actual road pattern are different, map matching does not function correctly and matches the location to a nearby road. The vehicle mark may deviate from the correct road.</p>	
Vehicle	<p>Use of tire chains</p>	<p>When tire chains are used, the mileage is not correctly detected, and the vehicle mark may deviate from the correct road.</p>	<p>Drive the vehicle for a while. If the distance is still deviated, adjust it by using the distance adjustment function. (If the tire chain is removed, recover the original value.)</p>

SQUEAK AND RATTLE TROUBLE DIAGNOSIS

SQUEAK AND RATTLE TROUBLE DIAGNOSIS

PFP:00000

Work Flow

AIS000BU

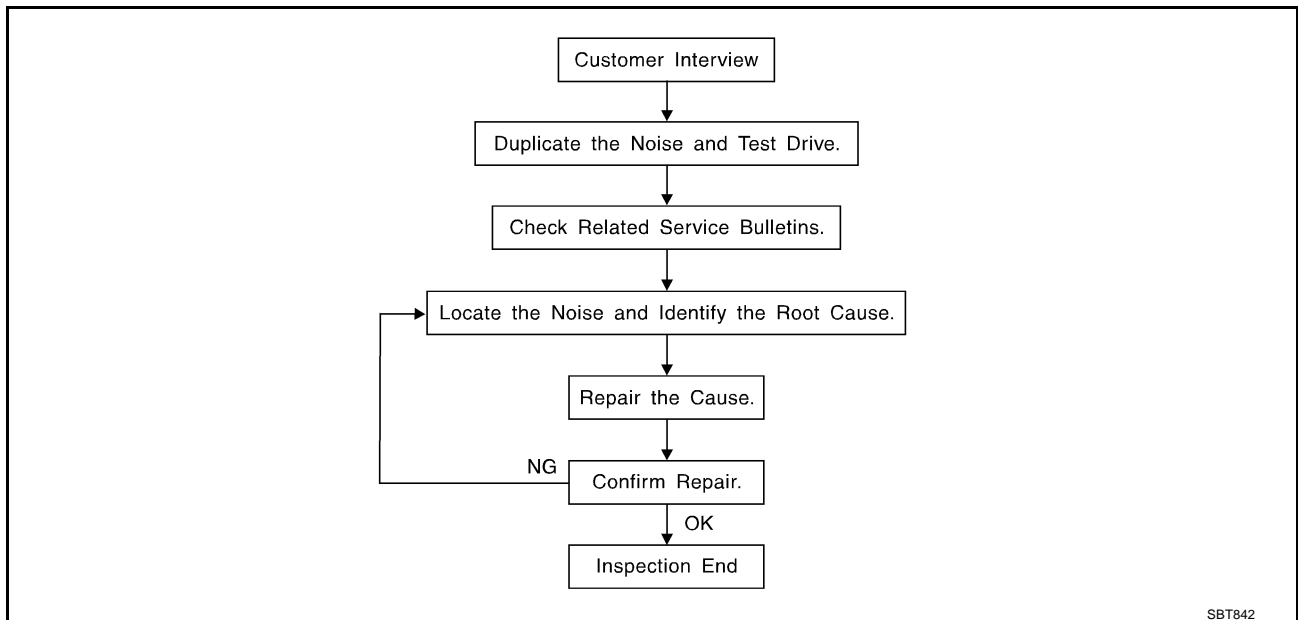

CUSTOMER INTERVIEW

Interview the customer if possible, to determine the conditions that exist when the noise occurs. Use the Diagnostic Worksheet during the interview to document the facts and conditions when the noise occurs and any customer's comments; refer to [BL-10, "Diagnostic Worksheet"](#). This information is necessary to duplicate the conditions that exist when the noise occurs.

- The customer may not be able to provide a detailed description or the location of the noise. Attempt to obtain all the facts and conditions that exist when the noise occurs (or does not occur).
- If there is more than one noise in the vehicle, be sure to diagnose and repair the noise that the customer is concerned about. This can be accomplished by test driving the vehicle with the customer.
- After identifying the type of noise, isolate the noise in terms of its characteristics. The noise characteristics are provided so the customer, service adviser and technician are all speaking the same language when defining the noise.
- Squeak —(Like tennis shoes on a clean floor)
Squeak characteristics include the light contact/fast movement/brought on by road conditions/hard surfaces=higher pitch noise/softer surfaces=lower pitch noises/edge to surface=chirping
- Creak—(Like walking on an old wooden floor)
Creak characteristics include firm contact/slow movement/twisting with a rotational movement/pitch dependent on materials/often brought on by activity.
- Rattle—(Like shaking a baby rattle)
Rattle characteristics include the fast repeated contact/vibration or similar movement/loose parts/missing clip or fastener/incorrect clearance.
- Knock —(Like a knock on a door)
Knock characteristics include hollow sounding/sometimes repeating/often brought on by driver action.
- Tick—(Like a clock second hand)
Tick characteristics include gentle contacting of light materials/loose components/can be caused by driver action or road conditions.
- Thump—(Heavy, muffled knock noise)
Thump characteristics include softer knock/dead sound often brought on by activity.
- Buzz—(Like a bumble bee)
Buzz characteristics include high frequency rattle/firm contact.
- Often the degree of acceptable noise level will vary depending upon the person. A noise that you may judge as acceptable may be very irritating to the customer.
- Weather conditions, especially humidity and temperature, may have a great effect on noise level.

POWER DOOR LOCK SYSTEM

3. CHECK BCM OUTPUT SIGNAL

Check power window serial link ("POWER WINDOW DOWN") in "ACTIVE TEST" mode with CONSULT-II. Refer to [BL-61, "Active Test"](#).

When "ACTIVE TEST" is executed, the window of driver side and passenger side are go down.

OK or NG

- OK >> Further inspection is necessary. Refer to symptom chart.
- NG >> Replace BCM.

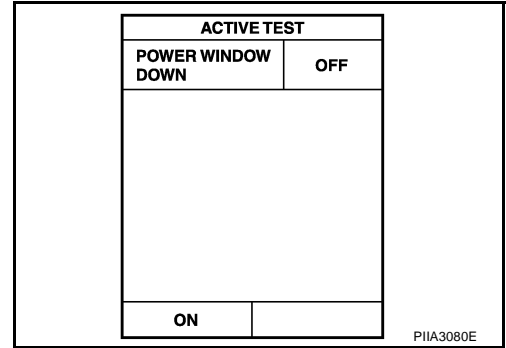

4. CHECK DOOR LOCK AND UNLOCK SWITCH GROUND HARNESS

1. Turn ignition switch OFF.
2. Disconnect power window main switch (door lock and unlock switch) and power window sub-switch (door lock and unlock switch) connector.
3. Check continuity between power window main switch (door lock and unlock switch) connector D7 terminal 15 and ground.

15 (B) – Ground

:Continuity should exist.

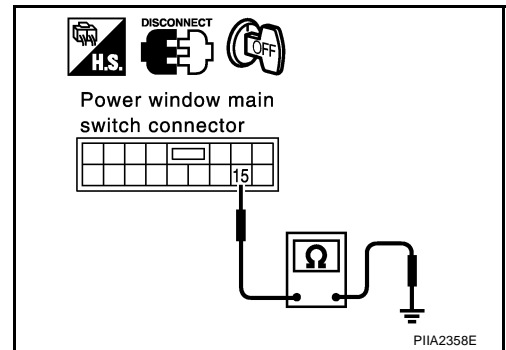

4. Check continuity between power window sub-switch (door lock and unlock switch) connector D37 terminal 11 and ground.

11 (B) – Ground

:Continuity should exist.

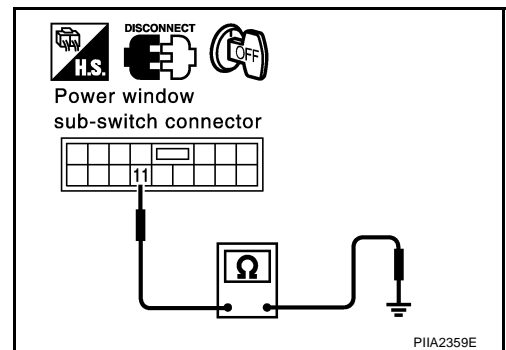

OK or NG

- OK >> GO TO 5.
- NG >> Repair or replace harness.

REMOTE KEYLESS ENTRY SYSTEM

Hazard and horn reminder mode

	ON (C mode)		OFF (S mode)		MODE 3		MODE 4		MODE 5		MODE 6	
	Lock	Unlock	Lock	Unlock	Lock	Unlock	Lock	Unlock	Lock	Unlock	Lock	Unlock
Key fob operation	Lock	Unlock	Lock	Unlock	Lock	Unlock	Lock	Unlock	Lock	Unlock	Lock	Unlock
Hazard warning lamp flash	Twice	Once	Twice	—	—	—	Twice	Once	Twice	—	—	Once
Horn sound	Once	—	—	—	—	—	—	—	Once	—	Once	—

Auto door lock operation mode

	MODE 1	MODE 2	MODE 3
Auto locking function	1 minutes	Nothing	5 minutes

Panic alarm operation mode

	MODE 1	MODE 2	MODE 3
Key fob operation	0.5 seconds	Nothing	1.5 seconds

Trunk lid open operation mode

	MODE 1	MODE 2	MODE 3
Key fob operation	0.5 seconds	Nothing	1.5 seconds

Power window down (open) operation mode

	MODE 1	MODE 2	MODE 3
Key fob operation	3 seconds	Nothing	5 seconds

Work Flow

AIS000CT

1. Check the trouble symptom and customer's requests.
2. Understand outline of system. Refer to [BL-51, "System Description"](#).
3. Confirm that power door lock system operates normally. Refer to [BL-18, "POWER DOOR LOCK SYSTEM"](#).
4. Refer to trouble diagnosis chart by symptom, repair or replace any malfunctioning parts. Refer to [BL-62, "Trouble Diagnosis Chart by Symptom"](#).
5. Inspection end.

Trouble Diagnosis Chart by Symptom

AIS000CV

NOTE:

- Always check the "Work Flow" before troubleshooting. Refer to [BL-62, "Work Flow"](#).
- Always check key fob battery before replacing key fob.
- The panic alarm operation, back door opener operation and keyless power window down operation of remote keyless entry system do not activate with the ignition key inserted in the ignition key cylinder.

Symptom	Diagnoses/service procedure	Reference page
All function of remote keyless entry system do not operate.	1. Key fob battery and function check	BL-64
	2. Replace key fob. Refer to ID Code Entry Procedure. NOTE: If the result of key fob function check with CONSULT-II is OK, key fob is not malfunctioning.	BL-71
	3. Replace BCM	BCS-15

TRUNK LID OPENER

6. Touch "TRUNK".

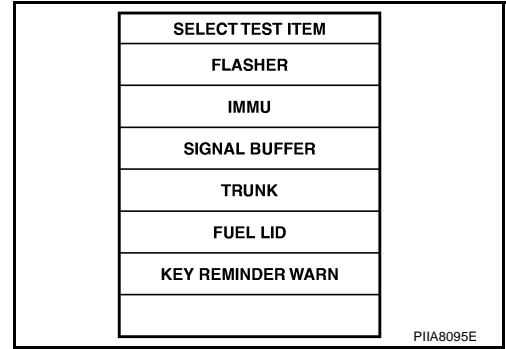

7. Select diagnosis mode.
"ACTIVE TEST"

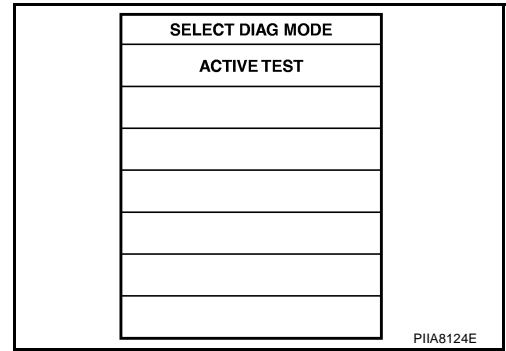

ACTIVE TEST

Test item	Content
TRUNK/BACK DOOR	This test is able to check trunk lid opener actuator unlock operation. This actuator unlocks when "ON" on CONSULT-II screen is touched.

VEHICLE SECURITY (THEFT WARNING) SYSTEM

Diagnostic Procedure 3 DOOR KEY CYLINDER SWITCH CHECK

AI500152

1. CHECK DOOR KEY CYLINDER SWITCH DRIVER SIDE OPERATION

Do doors lock/unlock when using the key?

YES or NO

YES >> Door key cylinder switch operation is OK.

NO >> Check door key cylinder switch circuit. Refer to [BL-40, "Door Key Cylinder Switch Check"](#) .

Diagnostic Procedure 4 VEHICLE SECURITY HORN ALARM CHECK

AI500153

First perform the "SELF-DIAG RESULTS" in "BCM" with CONSULT-II, then perform the trouble diagnosis of malfunction system indicated "SELF-DIAG RESULTS" of "BCM". Refer to [BCS-13, "CAN Communication Inspection Using CONSULT-II \(Self-Diagnosis\)"](#) .

1. CHECK HORN OPERATION

Check if horn sounds with horn switch.

Does horn operate?

Yes >> Check harness for open or short between IPDM E/R and horn relay.

No >> Check horn circuit. Refer to [WW-33, "HORN"](#) .

Diagnostic Procedure 5 VEHICLE SECURITY HEADLAMP ALARM CHECK

AI500154

1. CHECK HEAD LAMP OPERATION

Does headlamp come on when turning lighting switch "ON"?

YES or NO

YES >> Headlamp alarm circuit is OK.

NO >> Check headlamp system. Refer to [LT-6, "HEADLAMP \(FOR USA\)"](#) , [LT-29, "HEADLAMP \(FOR CANADA\) - DAYTIME LIGHT SYSTEM -"](#) .

Diagnostic Procedure 6 DOOR LOCK AND UNLOCK SWITCH CHECK

AI500155

1. CHECK DOOR LOCK AND UNLOCK SWITCH INPUT SIGNAL

Do doors lock/unlock when using power window main switch (door lock and unlock switch) or power window sub-switch (door lock and unlock switch)?

YES or NO?

YES >> Door lock and unlock switch is OK.

NO >> Refer to [BL-33, "Door Lock and Unlock Switch Check"](#) .

BODY REPAIR

AIS000EO

Corrosion Protection

DESCRIPTION

To provide improved corrosion prevention, the following anti-corrosive measures have been implemented in NISSAN production plants. When repairing or replacing body panels, it is necessary to use the same anti-corrosive measures.

Anti-corrosive Precoated Steel (Galvannealed Steel)

To improve repairability and corrosion resistance, a new type of anti-corrosive precoated steel sheet has been adopted replacing conventional zinc-coated steel sheet.

Galvannealed steel is electroplated and heated to form Zinc-iron alloy, which provides excellent and long term corrosion resistance with cationic electrodeposition primer.

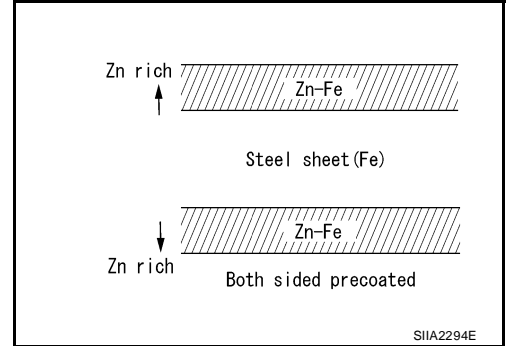

Nissan Genuine Service Parts are fabricated from galvannealed steel. Therefore, it is recommended that GENUINE NISSAN PARTS or equivalent be used for panel replacement to maintain the anti-corrosive performance built into the vehicle at the factory.

Phosphate Coating Treatment and Cationic Electrodeposition Primer

A phosphate coating treatment and a cationic electrodeposition primer, which provide excellent corrosion protection, are employed on all body components.

CAUTION:



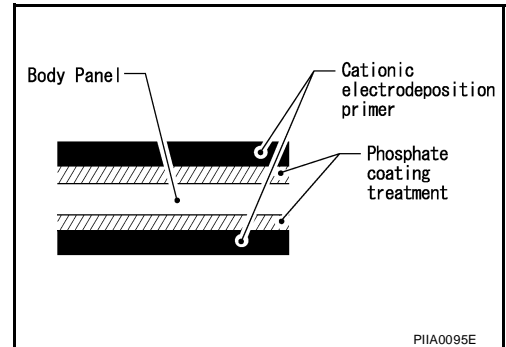





Confine paint removal during welding operations to an absolute minimum.

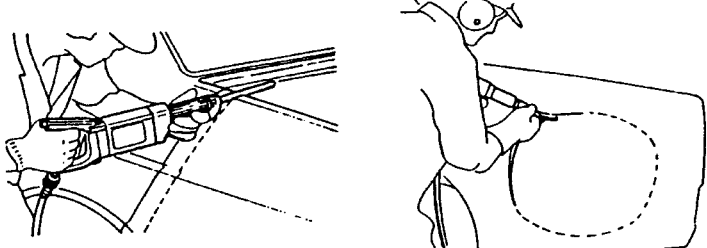
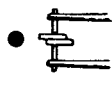
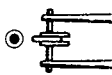

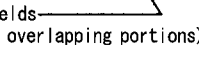
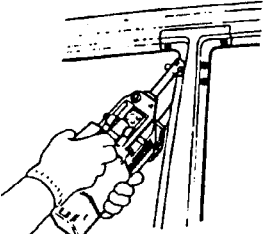
Nissan Genuine Service Parts are also treated in the same manner. Therefore, it is recommended that GENUINE NISSAN PARTS or equivalent be used for panel replacement to maintain anti-corrosive performance built into the vehicle at the factory.

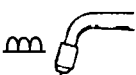
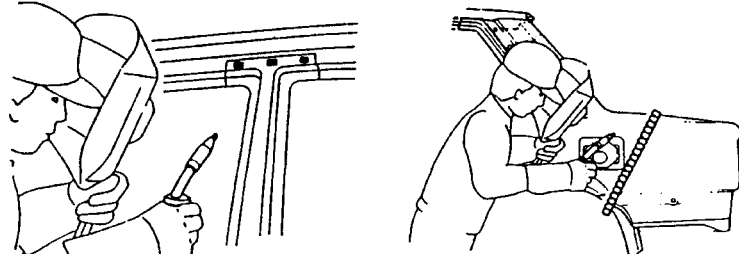
BODY REPAIR

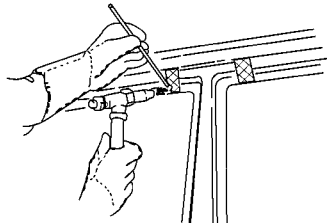
The symbols used in this section for cutting and welding / brazing operations are shown below.

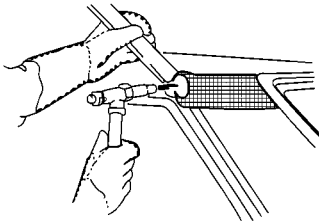
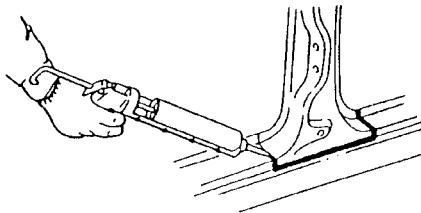
 <p>Saw cut or air chisel cut</p>		
<p>Spot weld</p> <p>●●●● 2-spot welds</p>  <p>●●●● 3-spot welds</p> 	<p>2-spot welds (2-panel overlapping portions)</p>  <p>3-spot welds (3-panel overlapping portions)</p> 	
<p>■ ■ ■ ■ MIG plug weld</p>  <p>⌒ ⌒ ⌒ ⌒ MIG seam weld/ Point weld</p> 		
<p>▨ ▨ ▨ ▨ Brazing</p> 		
<p>▩ ▩ ▩ ▩ Soldering</p> 		
<p>— Sealing</p>		

Bleeding Brake System

AFS000U0

CAUTION:

While bleeding, pay attention to master cylinder fluid level.

1. Turn ignition switch to OFF position.
2. Connect a vinyl tube to rear right air bleeder.
3. Fully depress brake pedal 4 to 5 times.
4. With the brake pedal depressed, loosen air bleeder to let the air out, and then tighten it immediately.
5. Repeat steps 3, 4 until no more air comes out.
6. Tighten air bleeder to the specified torque. Refer to [BR-20, "Components"](#) , [BR-26, "Components"](#) .
7. In steps 2 to 6 below, with master cylinder reservoir tank filled at least half way, bleed air from front left, rear left, and front right tires, in that order.

Precaution for Harness Repair CAN SYSTEM

- Area to be repaired shall be soldered, and wrapped with a tape (be sure that fraying of twisted wire shall be within 110 mm 4.33 in)).

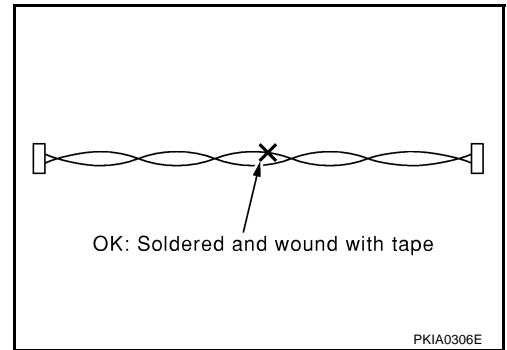

- Do not make a bypass connection to repaired area. (If it is done, branch part will be removed and characteristics of twisted wire will be lost.)

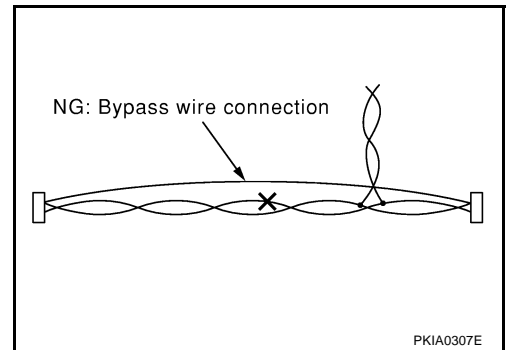

5. WHEEL SENSOR HARNESS INSPECTION

1. Turn ignition switch OFF and disconnect malfunctioning wheel sensor connector E42 (FR - LH), E27 (FR - RH) or T5 (RR - RH, LH) and ABS actuator and electric unit (control unit) connector.
2. Check the continuity between terminals. (Also check the continuity when steering wheel is turned right and left and when sensor harness inside the wheel well is moved.)

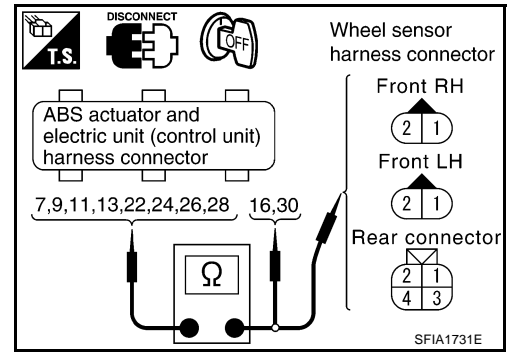

Wheel	Power system		Signal system		Ground system	
	ABS actuator and electric unit (control unit) harness connector E51	Wheel sensor	ABS actuator and electric unit (control unit) harness connector E51	Wheel sensor	ABS actuator and electric unit (control unit) harness connector E51 (Signal)	ABS actuator and electric unit (control unit) harness connector E51 (GND)
Front RH (E27)	24 (B/R)	1 (B/R)	9 (LG/B)	2 (LG/B)	9 (LG/B), 24 (B/R)	16 (B), 30(B)
Front LH (E42)	22 (G)	1 (G)	7 (G/Y)	2 (G/Y)	7 (G/Y), 22 (G)	16(B), 30(B)
Rear RH (T5)	28 (BR)	1 (BR/W)	13 (BR/W)	2 (BR)	13 (BR/W), 28 (BR)	16 (B), 30(B)
Rear LH (T5)	26 (OR)	3 (OR)	11(P)	4 (P)	11 (P), 26 (OR)	16 (B), 30(B)

- Power system** : Continuity should exist.
- Signal system** : Continuity should exist.
- Ground system** : Continuity should not exist.

OK or NG

- OK >> GO TO 6.
- NG >> Repair harness and connector between control unit and wheel sensor.

6. WHEEL SENSOR POWER CIRCUIT INSPECTION

1. Connect malfunctioning wheel sensor connector E42 (FR - LH), E27 (FR - RH) or T5 (RR - RH, LH) and ABS actuator and electric unit (control unit) connector.
2. Turn ignition switch ON and check the voltage between the power terminal and ground.

- Voltage**
- Front RH** **1 (B/R) - Ground** : 8V or more
- Front LH** **1 (G) - Ground** : 8V or more
- Rear RH** **1 (BR/W) - Ground** : 8V or more
- Rear LH** **3 (OR) - Ground** : 8V or more

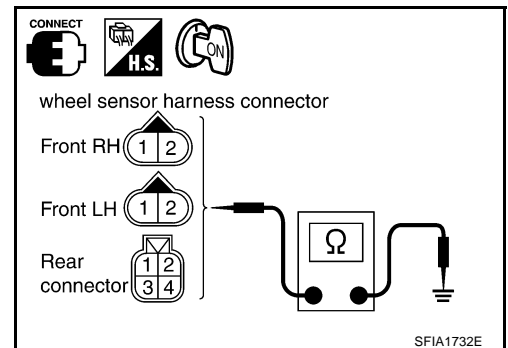

OK or NG

- OK >> Replace wheel sensor.
- NG >> Replace ABS actuator and electric unit (control unit).

CLUTCH DISC, CLUTCH COVER

Clutch Cover

Check diaphragm spring lever claws for unevenness with the lever still on the vehicle. If they exceed the tolerance, adjust lever height using a diaphragm adjusting wrench (special service tool).

**Tolerance for diaphragm spring lever unevenness:
0.5mm (0.020 in)**

- Check clutch cover thrust ring for wear or breakage. If wear or breakage is found, replace clutch cover assembly.

NOTE:

- Worn thrust ring will generate a beating noise when tapped at the rivet with a hammer.
- Broken thrust ring will make a clinking sound when cover is shaken up and down.
- If a trace of burn or discoloration is found on the clutch cover pressure plate to clutch disc contact surface, repair the surface with sandpaper. If surface is damaged or distorted, replace the assembly.

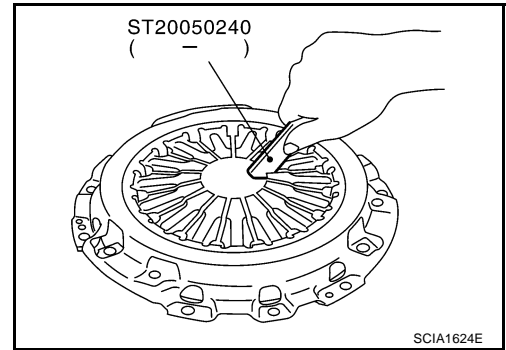

INSTALLATION

1. Apply recommended grease to clutch disc and main drive shaft spline.

CAUTION:

Be sure to apply grease to the points specified. Otherwise, noise, poor disengagement, or damage to the clutch may result. Excessive grease may cause slip or quiver. Wipe off any grease oozing from the parts.

2. Install clutch disc and clutch cover. Pre-tighten mounting bolts and install clutch aligning bar (special service tool).
3. Tighten clutch cover attaching bolts evenly in two steps in the order shown in the figure.

First step:

: 14.5 N·m (1.5 kg·m, 11 ft·lb)

Second step:

: 39.5 N·m (4.0 kg·m, 29 ft·lb)

4. Install manual transmission. Refer to [MT-19, "Removal and Installation from Vehicle"](#).

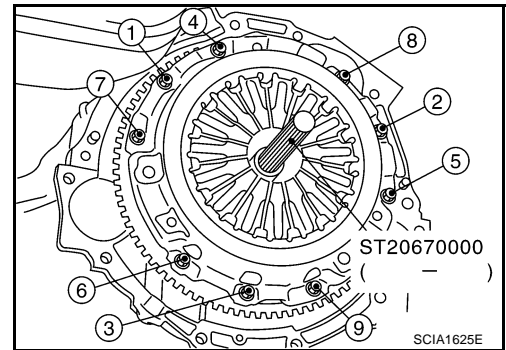

SERVICE DATA AND SPECIFICATIONS (SDS)

COMBINATION METERS

8. CHECK VOLTAGE SIGNAL OF UNIFIED METER AND A/C AMP.

1. Turn ignition switch OFF and connect unified meter and A/C amp. connector.
2. Turn ignition switch ON.
3. Check voltage signal between combination meter harness connector M19 terminal 22 (L/OR) and ground with simple oscilloscope of CONSULT-II.

22 (L/OR) - Ground:

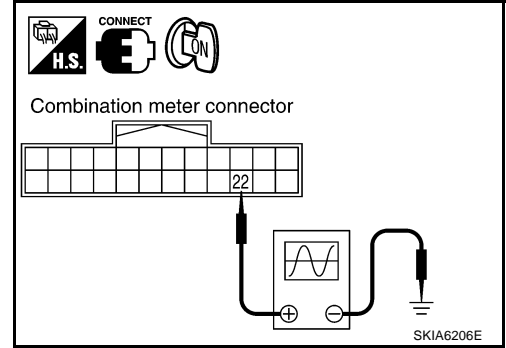
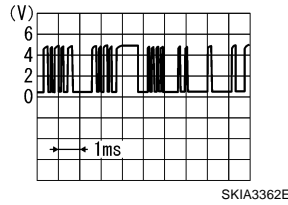

OK or NG

OK >> Replace combination meter.

NG >> Replace unified meter and A/C amp. Refer to [DI-65, "Removal and Installation of Unified Meter and A/C Amp."](#)

A/T Device Output Signal Inspection

AKS0094D

1. CHECK A/T DEVICE

Check manual mode switch system. Refer to [AT-168, "DTC P1815 MANUAL MODE SWITCH"](#).

OK or NG

OK >> Replace unified meter and A/C amp. Refer to [DI-65, "Removal and Installation of Unified Meter and A/C Amp."](#)

NG >> Replace applicable parts.

TRIPLE METERS

8. CHECK VOLTAGE SIGNAL OF UNIFIED METER AND A/C AMP.

1. Connect triple meter connector and unified meter and A/C amp. connector.
2. Ignition switch turn ON.
3. Check voltage signal between triple meter harness connector M44 terminal 5 (L/B) and ground with simple oscilloscope of CONSULT-II.

5 (L/B) - Ground :

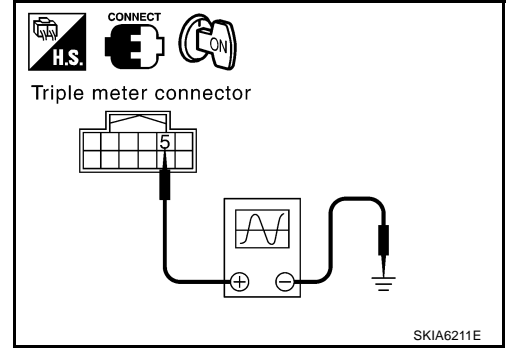
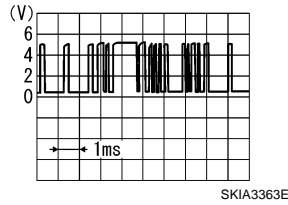

OK or NG

OK >> Replace triple meter.

NG >> Replace unified meter and A/C amp. Refer to [DI-65, "Removal and Installation of Unified Meter and A/C Amp."](#) .

Trip Computer Switch Inspection

AKS00952

1. CHECK CONNECTOR

1. Remove combination meter. Refer to [DI-32, "Removal and Installation for Combination Meter"](#) .
2. Remove rear finisher to combination meter. Refer to [DI-32, "Disassembly and Assembly for Combination Meter"](#) .
3. Check trip computer connector for looseness.

OK or NG

OK >> GO TO 2.

NG >> Repair trip computer switch connector.

2. CHECK CIRCUIT

1. Disconnect trip computer switch connector.
2. Check continuity between trip computer switch harness connector terminals 3, 4 and 5.

Terminal	Condition	Continuity
3	Mode switch is pushed.	Yes
	Mode switch is released.	No
4	Setting switch is pushed.	Yes
	Setting switch is released.	No

OK or NG

OK >> Replace combination meter.

NG >> Replace trip computer switch.

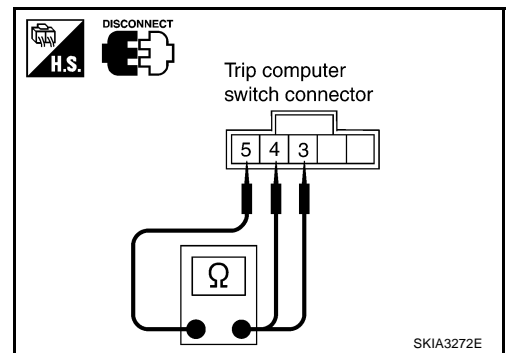

WARNING CHIME

Wiring Diagram — CHIME —

AKS0095M

DI-CHIME-01

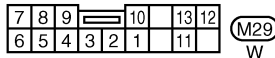
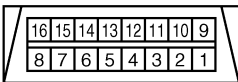
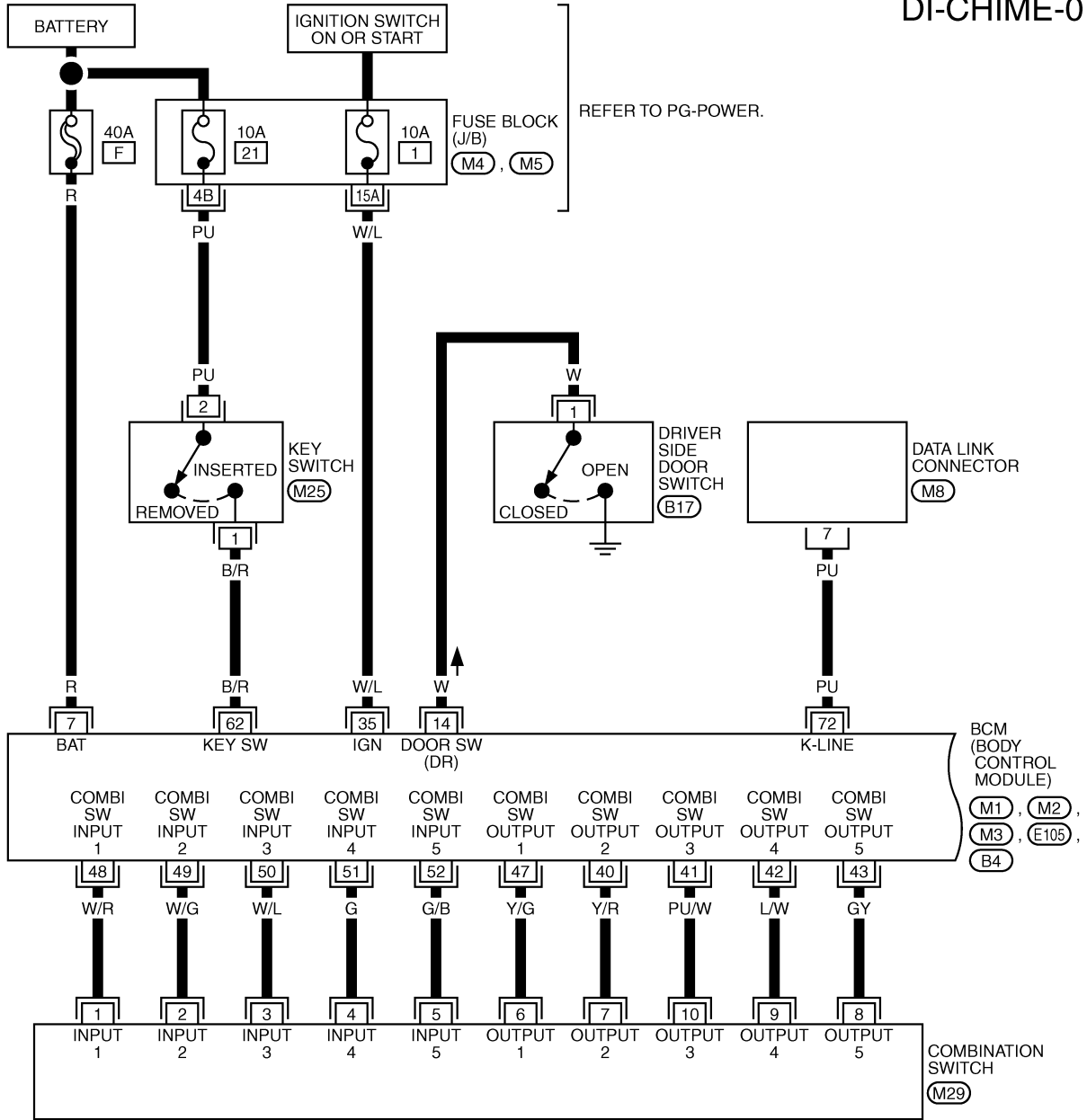

REFER TO THE FOLLOWING.

- (M4), (M5) - FUSE BLOCK-JUNCTION BOX (J/B)
- (M1), (M2), (M3), (E105), (B4) - ELECTRICAL UNITS

TKWT0809E

INDEX FOR DTC

DTC No. Index

ABS000R4

NOTE:

If DTC U1000 or U1001 is displayed with other DTC, first perform the trouble diagnosis for DTC U1000, U1001. Refer to [EC-135, "DTC U1000, U1001 CAN COMMUNICATION LINE"](#) .

×:Applicable —: Not applicable

DTC*1		Items (CONSULT-II screen terms)	Trip	MIL lighting up	Reference page
CONSULT-II GST*2	ECM*3				
No DTC	Flashing*4	NO DTC IS DETECTED. FURTHER TESTING MAY BE REQUIRED.	—	Flashing*4	EC-63
U1000	1000*5	CAN COMM CIRCUIT	1	×	EC-135
U1001	1001*5	CAN COMM CIRCUIT	2	—	EC-135
P0000	0000	NO DTC IS DETECTED. FURTHER TESTING MAY BE REQUIRED.	—	—	—
P0011	0011	INT/V TIM CONT-B1	2	×	EC-138
P0021	0021	INT/V TIM CONT-B2	2	×	EC-138
P0031	0031	HO2S1 HTR (B1)	2	×	EC-141
P0032	0032	HO2S1 HTR (B1)	2	×	EC-141
P0037	0037	HO2S2 HTR (B1)	2	×	EC-149
P0038	0038	HO2S2 HTR (B1)	2	×	EC-149
P0051	0051	HO2S1 HTR (B2)	2	×	EC-141
P0052	0052	HO2S1 HTR (B2)	2	×	EC-141
P0057	0057	HO2S2 HTR (B2)	2	×	EC-149
P0058	0058	HO2S2 HTR (B2)	2	×	EC-149
P0101	0101	MAF SEN/CIRCUIT	1	×	EC-157
P0102	0102	MAF SEN/CIRCUIT	1	×	EC-165
P0103	0103	MAF SEN/CIRCUIT	1	×	EC-165
P0112	0112	IAT SEN/CIRCUIT	2	×	EC-172
P0113	0113	IAT SEN/CIRCUIT	2	×	EC-172
P0117	0117	ECT SEN/CIRCUIT	1	×	EC-177
P0118	0118	ECT SEN/CIRCUIT	1	×	EC-177
P0122	0122	TP SEN 2/CIRC	1	×	EC-182
P0123	0123	TP SEN 2/CIRC	1	×	EC-182
P0125	0125	ECT SENSOR	1	×	EC-189
P0127	0127	IAT SENSOR	2	×	EC-192
P0128	0128	THERMSTAT FNCTN	2	×	EC-195
P0132	0132	HO2S1 (B1)	2	×	EC-197
P0133	0133	HO2S1 (B1)	2	×	EC-207
P0134	0134	HO2S1 (B1)	2	×	EC-220
P0138	0138	HO2S2 (B1)	2	×	EC-230
P0139	0139	HO2S2 (B1)	2	×	EC-239
P0152	0152	HO2S1 (B2)	2	×	EC-197
P0153	0153	HO2S1 (B2)	2	×	EC-207
P0154	0154	HO2S1 (B2)	2	×	EC-220
P0158	0158	HO2S2 (B2)	2	×	EC-230

BASIC SERVICE PROCEDURE

27. PERFORM IDLE AIR VOLUME LEARNING

Refer to [EC-42, "Idle Air Volume Learning"](#) .

Is Idle Air Volume Learning carried out successfully?

Yes or No

Yes (With CONSULT-II)>>GO TO 28.

Yes (Without CONSULT-II)>>GO TO 29.

No >> 1. Follow the instruction of Idle Air Volume Learning.
2. GO TO 4.

28. CHECK CO%

 With CONSULT-II

1. Start engine and warm it up until engine coolant temperature indicator points the middle of gauge.
2. Turn ignition switch OFF, wait at least 10 seconds and then turn ON.
3. Select "ENG COOLANT TEMP" in "ACTIVE TEST" mode.
4. Set "ENG COOLANT TEMP" to 5°C (41°F) by touching "DWN" and "Qd".
5. Start engine and rev it (2,000 to 3,000 rpm) two or three times under no-load, then run engine at idle speed.
6. Check CO%.

Idle CO: 0.7 – 9.9% and engine runs smoothly.

OK or NG

OK >> GO TO 31.

NG >> GO TO 30.

ACTIVE TEST	
ENG COOLANT TEMP	XXX °C
MONITOR	
ENG SPEED	XXX rpm
INJ PULSE-B1	XXX msec
IGN TIMING	XXX BTDC

SEF172Y

29. CHECK CO%

 Without CONSULT-II

1. Start engine and warm it up until engine coolant temperature indicator points to the middle of gauge.
2. Turn ignition switch OFF.
3. Disconnect engine coolant temperature sensor harness connector.
4. Connect a resistor (4.4 kΩ) between terminals of engine coolant temperature sensor harness connector.
5. Start engine and rev it (2,000 to 3,000 rpm) two or three times under no-load, then run engine at idle speed.
6. Check CO%.

Idle CO: 0.7 – 9.9% and engine runs smoothly.

7. After checking CO%, turn ignition switch OFF, disconnect the resistor from the terminals of engine coolant temperature sensor harness connector, and then connect engine coolant temperature sensor harness connector to engine coolant temperature sensor.

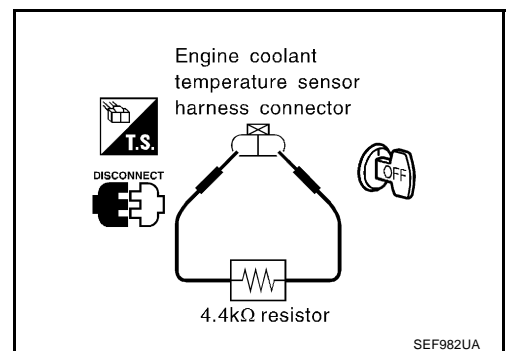

OK or NG

OK >> GO TO 31.

NG >> GO TO 30.

30. RECONNECT HEATED OXYGEN SENSOR 1 HARNESS CONNECTOR

1. Turn ignition switch OFF.
2. Reconnect heated oxygen sensor 1 harness connector.

>> GO TO 34.

ON BOARD DIAGNOSTIC (OBD) SYSTEM

EXPLANATION FOR DRIVING PATTERNS FOR “MISFIRE <EXHAUST QUALITY DETERIORATION>”, “FUEL INJECTION SYSTEM”

<Driving Pattern B>

Driving pattern B means the vehicle operation as follows:

All components and systems should be monitored at least once by the OBD system.

- The B counter will be cleared when the malfunction is detected once regardless of the driving pattern.
- The B counter will be counted up when driving pattern B is satisfied without any malfunction.
- The MIL will go off when the B counter reaches 3. (*2 in OBD SYSTEM OPERATION CHART)

<Driving Pattern C>

Driving pattern C means the vehicle operation as follows:

The following conditions should be satisfied at the same time:

Engine speed: (Engine speed in the freeze frame data) ± 375 rpm

Calculated load value: (Calculated load value in the freeze frame data) $\times (1 \pm 0.1)$ [%]

Engine coolant temperature (T) condition:

- When the freeze frame data shows lower than 70°C (158°F), T should be lower than 70°C (158°F).
- When the freeze frame data shows higher than or equal to 70°C (158°F), T should be higher than or equal to 70°C (158°F).

Example:

If the stored freeze frame data is as follows:

Engine speed: 850 rpm, Calculated load value: 30%, Engine coolant temperature: 80°C (176°F)

To be satisfied with driving pattern C, the vehicle should run under the following conditions:

Engine speed: 475 - 1,225 rpm, Calculated load value: 27 - 33%, Engine coolant temperature: more than 70°C (158°F)

- The C counter will be cleared when the malfunction is detected regardless of vehicle conditions above.
- The C counter will be counted up when vehicle conditions above is satisfied without the same malfunction.
- The DTC will not be displayed after C counter reaches 80.
- The 1st trip DTC will be cleared when C counter is counted once without the same malfunction after DTC is stored in ECM.

TROUBLE DIAGNOSIS

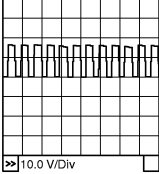
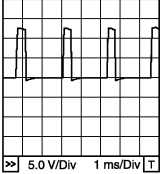
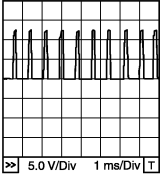
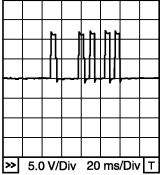
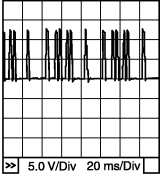
TER-MINAL NO.	WIRE COLOR	ITEM	CONDITION	DATA (DC Voltage)
11	P	Intake valve timing control solenoid valve (bank 1)	[Engine is running] ● Warm-up condition ● Idle speed	BATTERY VOLTAGE (11 - 14V)
			[Engine is running] ● Warm-up condition ● When revving engine up to 2,500 rpm quickly	7 - 12V★  PBIB1790E
12	L/W	Power steering pressure sensor	[Engine is running] ● Steering wheel is being turned.	0.5 - 4.5V
			[Engine is running] ● Steering wheel is not being turned.	0.4 - 0.8V
13	W/L	Crankshaft position sensor (POS)	[Engine is running] ● Warm-up condition ● Idle speed	Approximately 1.6V★  PBIB1041E
			[Engine is running] ● Engine speed is 2,000 rpm.	Approximately 1.4V★  PBIB1042E
14	R/L	Camshaft position sensor (PHASE) (bank 2)	[Engine is running] ● Warm-up condition ● Idle speed	1.0 - 4.0V★  PBIB1039E
			[Engine is running] ● Engine speed is 2,000 rpm.	1.0 - 4.0V★  PBIB1040E
15	W	Knock sensor	[Engine is running] ● Idle speed	Approximately 2.5V
16	L/G	Heated oxygen sensor 1 (bank 2)	[Engine is running] ● Warm-up condition ● Engine speed is 2,000 rpm.	0 - Approximately 1.0V (Periodically change)

TROUBLE DIAGNOSIS - SPECIFICATION VALUE

Diagnostic Procedure

ABS000SB

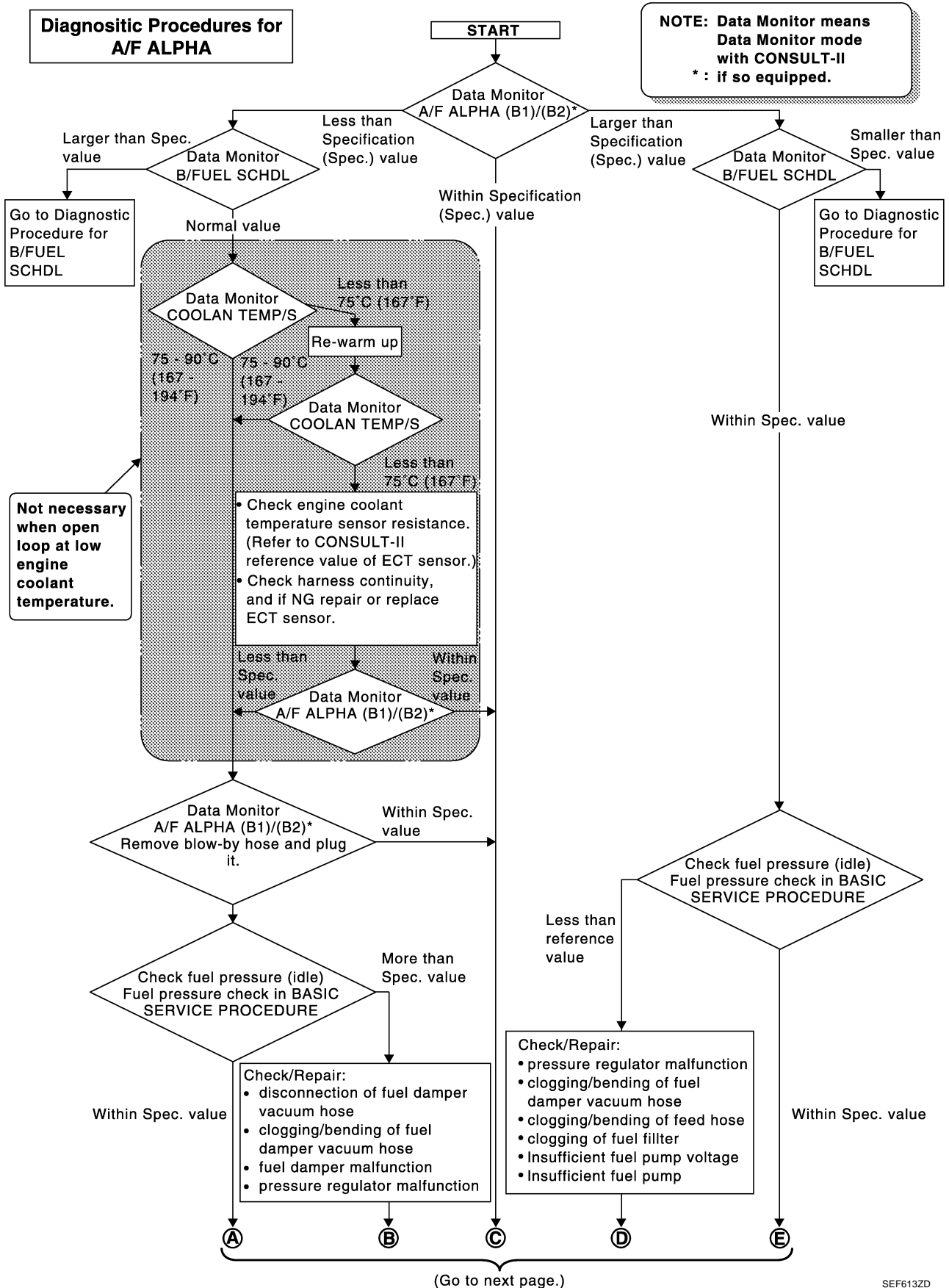

SEF613ZD

DTC P0037, P0038, P0057, P0058 HO2S2 HEATER

Specification data are reference values and are measured between each terminal and ground.

CAUTION:

Do not use ECM ground terminals when measuring input/output voltage. Doing so may result in damage to the ECM's transistor. Use a ground other than ECM terminals, such as the ground.

TER-MINAL NO.	WIRE COLOR	ITEM	CONDITION	DATA (DC Voltage)
25	P/B	Heated oxygen sensor 2 heater (bank 1)	[Engine is running] <ul style="list-style-type: none"> ● Engine speed is below 3,600 rpm after the following conditions are met. <ul style="list-style-type: none"> - Engine: after warming up - Keeping the engine speed between 3,500 and 4,000 rpm for 1 minute and at idle for 1 minute under no load. 	0 - 1.0V
			[Ignition switch: ON] <ul style="list-style-type: none"> ● Engine stopped [Engine is running] <ul style="list-style-type: none"> ● Engine speed is above 3,600 rpm. 	BATTERY VOLTAGE (11 - 14V)

DTC P0117, P0118 ECT SENSOR

ABS000U1

Diagnostic Procedure

1. CHECK ECT SENSOR POWER SUPPLY CIRCUIT

1. Turn ignition switch OFF.
2. Disconnect engine coolant temperature (ECT) sensor harness connector.
3. Turn ignition switch ON.

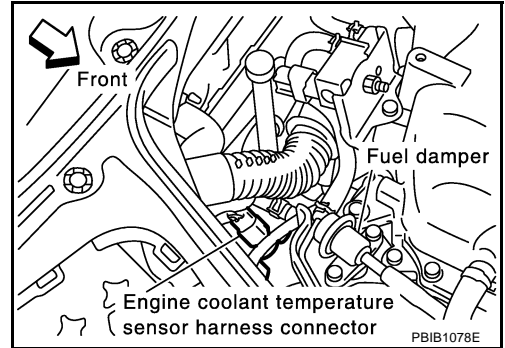

4. Check voltage between ECT sensor terminal 1 and ground with CONSULT-II or tester.

Voltage: Approximately 5V

OK or NG

OK >> GO TO 2.

NG >> Repair open circuit or short to ground or short to power in harness or connectors.

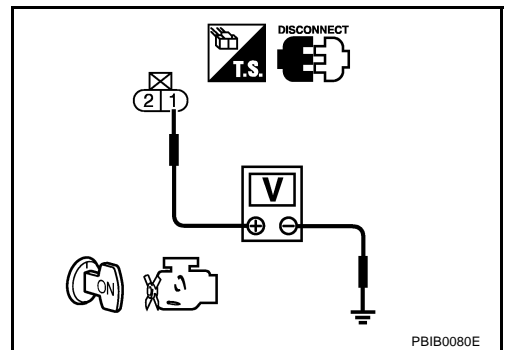

2. CHECK ECT SENSOR GROUND CIRCUIT FOR OPEN AND SHORT

1. Turn ignition switch OFF.
2. Disconnect ECM harness connector.
3. Check harness continuity between ECT sensor terminal 2 and ECM terminal 67. Refer to Wiring Diagram.

Continuity should exist.

4. Also check harness for short to ground and short to power.

OK or NG

OK >> GO TO 3.

NG >> Repair open circuit or short to ground or short to power in harness or connectors.

3. CHECK ENGINE COOLANT TEMPERATURE SENSOR

Refer to [EC-181, "Component Inspection"](#) .

OK or NG

OK >> GO TO 4.

NG >> Replace engine coolant temperature sensor.

4. CHECK INTERMITTENT INCIDENT

Refer to [EC-127, "TROUBLE DIAGNOSIS FOR INTERMITTENT INCIDENT"](#) .

>> INSPECTION END

DTC P0133, P0153 HO2S1

DTC No.	Trouble diagnosis name	DTC detecting condition	Possible cause
P0133 0133 (Bank 1)	Heated oxygen sensor 1 circuit slow response	The response of the voltage signal from the sensor takes more than the specified time.	<ul style="list-style-type: none"> ● Harness or connectors (The sensor circuit is open or shorted) ● Heated oxygen sensor 1 ● Fuel pressure ● Injectors ● Intake air leaks ● Exhaust gas leaks ● PCV valve ● Mass air flow sensor
P0153 0153 (Bank 2)			

DTC Confirmation Procedure

ABS000V7

CAUTION:

Always drive vehicle at a safe speed.

NOTE:

If DTC Confirmation Procedure has been previously conducted, always turn ignition switch OFF and wait at least 10 seconds before conducting the next test.

TESTING CONDITION:

Before performing the following procedure, confirm that battery voltage is more than 11V at idle.

WITH CONSULT-II

1. Start engine and warm it up to normal operating temperature.
2. Stop engine and wait at least 10 seconds.
3. Turn ignition switch ON and select "HO2S1 (B1) P0133" or "HO2S1 (B2) P0153" of "HO2S1" in "DTC WORK SUPPORT" mode with CONSULT-II.
4. Touch "START".
5. Start engine and let it idle for at least 3 minutes.

NOTE:

Never raise engine speed above 3,600 rpm after this step. If the engine speed limit is exceeded, return to step 5.

HO2S1 (B1) P0133	
OUT OF CONDITION	
MONITOR	
ENG SPEED	XXX rpm
B/FUEL SCHDL	XXX msec
COOLAN TEMP/S	XXX °C
VHCL SPEED SEN	XXX km/h

SEF338Z

6. When the following conditions are met, "TESTING" will be displayed on the CONSULT-II screen. Maintain the conditions continuously until "TESTING" changes to "COMPLETED". (It will take approximately 20 to 50 seconds.)

ENG SPEED	1,200 - 3,100 rpm
Vehicle speed	More than 80 km/h (50 MPH)
B/FUEL SCHDL	2.5 - 12.0 msec
Selector lever	Suitable position

HO2S1 (B1) P0133	
TESTING	
MONITOR	
ENG SPEED	XXX rpm
B/FUEL SCHDL	XXX msec
COOLAN TEMP/S	XXX °C
VHCL SPEED SEN	XXX km/h

SEF339Z

If "TESTING" is not displayed after 5 minutes, retry from step 2.

DTC P0138, P0158 HO2S2

3. CHECK HO2S2 INPUT SIGNAL CIRCUIT FOR OPEN AND SHORT

1. Check harness continuity between ECM terminal and HO2S2 terminal as follows.
Refer to Wiring Diagram.

DTC	Terminals		Bank
	ECM	Sensor	
P0138	74	1	1
P0158	55	1	2

Continuity should exist.

2. Check harness continuity between the following terminals and ground.
Refer to Wiring Diagram.

DTC	Terminals		Bank
	ECM	Sensor	
P0138	74	1	1
P0158	55	1	2

Continuity should not exist.

3. Also check harness for short to power.

OK or NG

OK >> GO TO 4.

NG >> Repair open circuit or short to ground or short to power in harness or connectors.

4. CHECK HO2S2 CONNECTOR FOR WATER

1. Turn ignition switch OFF.
2. Disconnect heated oxygen sensor 2 harness connector.
3. Check connectors for water.

Water should not exist.

OK or NG

OK >> GO TO 5.

NG >> Repair or replace harness or connectors.

5. CHECK HEATED OXYGEN SENSOR 2

Refer to [EC-237, "Component Inspection"](#) .

OK or NG

OK >> GO TO 6.

NG >> Replace malfunctioning heated oxygen sensor 2.

6. CHECK INTERMITTENT INCIDENT

Refer to [EC-127, "TROUBLE DIAGNOSIS FOR INTERMITTENT INCIDENT"](#) .

>> INSPECTION END

DTC P0172, P0175 FUEL INJECTION SYSTEM FUNCTION

6. CHECK MASS AIR FLOW SENSOR

With CONSULT-II

1. Install all removed parts.
2. Check "MASS AIR FLOW" in "DATA MONITOR" mode with CONSULT-II.

2.0 - 6.0 g-m/sec: at idling
7.0 - 20.0 g-m/sec: at 2,500 rpm

With GST

1. Install all removed parts.
2. Check mass air flow sensor signal in "MODE 1" with GST.

2.0 - 6.0 g-m/sec: at idling
7.0 - 20.0 g-m/sec: at 2,500 rpm

OK or NG

OK >> GO TO 7.

NG >> Check connectors for rusted terminals or loose connections in the mass air flow sensor circuit or engine grounds. Refer to [EC-157, "DTC P0101 MAF SENSOR"](#) .

7. CHECK FUNCTION OF INJECTORS

With CONSULT-II

1. Start engine.
2. Perform "POWER BALANCE" in "ACTIVE TEST" mode with CONSULT-II.
3. Make sure that each circuit produces a momentary engine speed drop.

ACTIVE TEST	
POWER BALANCE	
MONITOR	
ENG SPEED	XXX rpm
MAS A/F SE-B1	XXX V

PBIB0133E

Without CONSULT-II

1. Start engine.
2. Listen to each injector operating sound.

Clicking noise should be heard.

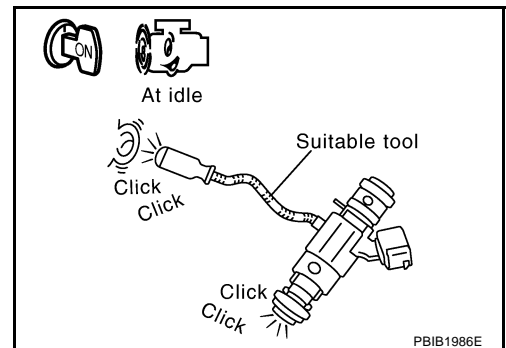

OK or NG

OK >> GO TO 8.

NG >> Perform trouble diagnosis for [EC-581, "INJECTOR CIRCUIT"](#) .

Removal and Installation
KNOCK SENSOR

ABS000XV

Refer to [EM-95, "CYLINDER BLOCK"](#) .

DTC P0442 EVAP CONTROL SYSTEM

5. INSTALL THE PRESSURE PUMP

To locate the EVAP leak, install EVAP service port adapter and pressure pump to EVAP service port securely. For the location of EVAP service port, refer to [EC-622, "EVAPORATIVE EMISSION LINE DRAWING"](#).

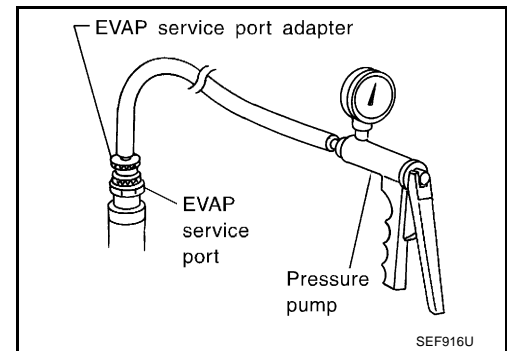
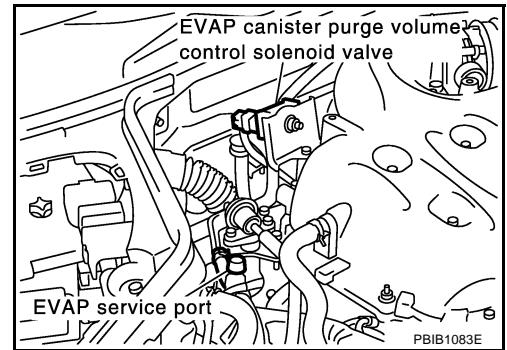

NOTE:

Improper installation of the EVAP service port adapter to the EVAP service port may cause leaking.

Models with CONSULT-II>>GO TO 6.

Models without CONSULT-II>>GO TO 7.

DTC P0452 EVAP CONTROL SYSTEM PRESSURE SENSOR

7. CHECK EVAP CONTROL SYSTEM PRESSURE SENSOR INPUT SIGNAL CIRCUIT FOR OPEN AND SHORT

1. Check harness continuity between ECM terminal 32 and EVAP control system pressure sensor terminal 2.
2. Refer to Wiring Diagram.

Continuity should exist.

2. Also check harness for short to ground and short to power.

OK or NG

- OK >> GO TO 9.
NG >> GO TO 8.

8. DETECT MALFUNCTIONING PART

Check the following.

- Harness connectors T22, B60
- Harness connectors B1, M12
- Harness connectors M72, F102
- Harness for open or short between EVAP control system pressure sensor and ECM

>> Repair open circuit or short to ground or short to power in harness or connectors.

9. CHECK EVAP CONTROL SYSTEM PRESSURE SENSOR

Refer to [EC-348, "Component Inspection"](#) .

OK or NG

- OK >> GO TO 10.
NG >> Replace EVAP control system pressure sensor.

10. CHECK INTERMITTENT INCIDENT

Refer to [EC-127, "TROUBLE DIAGNOSIS FOR INTERMITTENT INCIDENT"](#) .

>> **INSPECTION END**

Component Inspection EVAP CONTROL SYSTEM PRESSURE SENSOR

ABS000Z9

1. Remove EVAP control system pressure sensor with its harness connector connected from EVAP canister.
Do not reuse the O-ring, replace it with a new one.
2. Install a vacuum pump to EVAP control system pressure sensor.
3. Turn ignition switch ON and check output voltage between ECM terminal 32 and ground under the following conditions.

Applied vacuum kPa (mmHg, inHg)	Voltage V
Not applied	1.8 - 4.8
-26.7 (-200, -7.87)	2.1 to 2.5V lower than above value

CAUTION:

- Always calibrate the vacuum pump gauge when using it.
 - Do not apply below -93.3 kPa (-700 mmHg, -27.56 inHg) or pressure over 101.3 kPa (760 mmHg, 29.92 inHg).
4. If NG, replace EVAP control system pressure sensor.

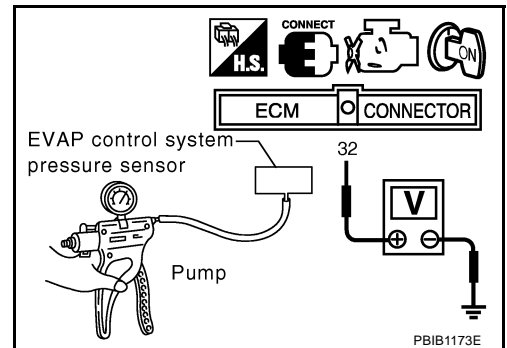

CLICK HERE TO **DOWNLOAD** THE COMPLETE MANUAL

- Thank you very much for reading the preview of the manual.
- You can download the complete manual from: www.heydownloads.com by clicking the link below



- Please note: If there is no response to CLICKING the link, please download this PDF first and then click on it.

CLICK HERE TO **DOWNLOAD** THE COMPLETE MANUAL

DTC P0460 FUEL LEVEL SENSOR

Diagnostic Procedure

ABS00108

1. CHECK DTC WITH UNIFIED METER AND A/C AMP.

Refer to [DI-63, "SELF-DIAGNOSIS RESULTS"](#) .

OK or NG

OK >> GO TO 2.

NG >> Go to [DI-24, "Fuel Level Sensor Signal Inspection 3"](#) .

2. CHECK INTERMITTENT INCIDENT

Refer to [EC-127, "TROUBLE DIAGNOSIS FOR INTERMITTENT INCIDENT"](#) .

>> INSPECTION END

Removal and Installation FUEL LEVEL SENSOR

ABS00109

Refer to [FL-5, "FUEL LEVEL SENSOR UNIT, FUEL FILTER AND FUEL PUMP ASSEMBLY"](#) .

DTC P1111, P1136 IVT CONTROL SOLENOID VALVE

2. DETECT MALFUNCTIONING PART

Check the following.

- Harness connectors E12, F3
- Harness connectors F18, F201
- IPDM E/R harness connector E8
- Harness for open or short between intake valve timing control solenoid valve and IPDM E/R

>> Repair harness or connectors.

3. CHECK INTAKE VALVE TIMING CONTROL SOLENOID VALVE OUTPUT SIGNAL CIRCUIT FOR OPEN AND SHORT

1. Turn ignition switch OFF.
2. Disconnect ECM harness connector.
3. Check harness continuity between ECM terminal 11 (bank 1) or 10 (bank 2) and intake valve timing control solenoid valve terminal 1. Refer to Wiring Diagram.

Continuity should exist.

4. Also check harness for short to ground and short to power.

OK or NG

- OK >> GO TO 5.
- NG >> GO TO 4.

4. DETECT MALFUNCTIONING PART

Check the following.

- Harness connectors F18, F201
- Harness for open and short between ECM and intake valve timing control solenoid valve

>> Repair open circuit or short to ground or short to power in harness or connectors.

5. CHECK INTAKE VALVE TIMING CONTROL SOLENOID VALVE

Refer to [EC-405, "Component Inspection"](#) .

OK or NG

- OK >> GO TO 6.
- NG >> Replace intake valve timing control solenoid valve.

6. CHECK INTERMITTENT INCIDENT

Refer to [EC-127, "TROUBLE DIAGNOSIS FOR INTERMITTENT INCIDENT"](#) .

For wiring diagram, refer to [EC-294](#) for CKP sensor (POS), [EC-300](#) and [EC-302](#) for CMP sensor (PHASE).

>> **INSPECTION END**

DTC Confirmation Procedure

CAUTION:

Always drive vehicle at a safe speed.

NOTE:

If DTC Confirmation Procedure has been previously conducted, always turn ignition switch OFF and wait at least 10 seconds before conducting the next test.

TESTING CONDITION:

- Always perform at a temperature above -10°C (14°F).
- Before performing the following procedure, confirm that battery voltage is more than 11V at idle.

WITH CONSULT-II

1. Start engine and warm it up to normal operating temperature.
2. Stop engine and wait at least 5 seconds.
3. Turn ignition switch ON and select "HO2S1 (B1) P1144" or "HO2S1 (B2) P1164" of "HO2S1" in "DTC WORK SUPPORT" mode with CONSULT-II.
4. Touch "START".
5. Start engine and let it idle for at least 3 minutes.

NOTE:

Never raise engine speed above 3,600 rpm after this step. If the engine speed limit is exceeded, return to step 5.

HO2S1 (B1) P1144	
OUT OF CONDITION	
MONITOR	
ENG SPEED	XXX rpm
B/FUEL SCHDL	XXX msec
COOLAN TEMP/S	XXX °C
VHCL SPEED SEN	XXX km/h

PBIB0548E

6. When the following conditions are met, "TESTING" will be displayed on the CONSULT-II screen. Maintain the conditions continuously until "TESTING" changes to "COMPLETED". (It will take approximately 40 seconds or more.)

ENG SPEED	1,200 - 2,600 rpm
Vehicle speed	Less than 100 km/h (62 MPH)
B/FUEL SCHDL	2.5 - 12.0 msec
Selector lever	Suitable position

HO2S1 (B1) P1144	
TESTING	
MONITOR	
ENG SPEED	XXX rpm
B/FUEL SCHDL	XXX msec
COOLAN TEMP/S	XXX °C
VHCL SPEED SEN	XXX km/h

PBIB0549E

If "TESTING" is not displayed after 5 minutes, retry from step 2.

7. Make sure that "OK" is displayed after touching "SELF-DIAG RESULTS". If "NG" is displayed, refer to [EC-433, "Diagnostic Procedure"](#).

HO2S1 (B1) P1144	
COMPLETED	

SEC772C

DTC P1148, P1168 CLOSED LOOP CONTROL

WITH GST

1. Start engine and warm it up to normal operating temperature.
2. Set voltmeter probes between ECM terminal 35 [HO2S1 (B1) signal] or 16 [HO2S1 (B2) signal] and engine ground.
3. Check the following with engine speed held at 2,000 rpm constant under no-load.
 - The voltage should go above 0.70V at least once.
 - The voltage should go below 0.21V at least once.
4. If NG, go to [EC-460, "Diagnostic Procedure"](#) .

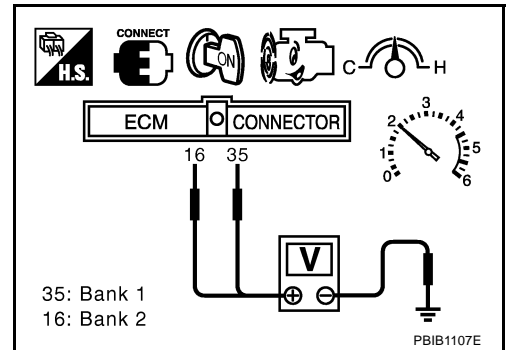

Diagnostic Procedure

Perform trouble diagnosis for DTC P0133, P0153. Refer to [EC-213, "Diagnostic Procedure"](#) .

ABS00136

DTC P1444 EVAP CANISTER PURGE VOLUME CONTROL SOLENOID VALVE

Specification data are reference values and are measured between each terminal and ground.
Pulse signal is measured by CONSULT-II.

CAUTION:

Do not use ECM ground terminals when measuring input/output voltage. Doing so may result in damage to the ECM's transistor. Use a ground other than ECM terminals, such as the ground.

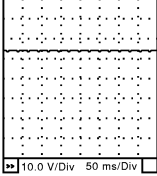
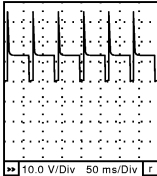
TER-MINAL NO.	WIRE COLOR	ITEM	CONDITION	DATA (DC Voltage)
45	G/W	EVAP canister purge volume control solenoid valve	<p>[Engine is running]</p> <ul style="list-style-type: none"> ● Idle speed 	<p>BATTERY VOLTAGE (11 - 14V)★</p>  <p>SEC990C</p>
			<p>[Engine is running]</p> <ul style="list-style-type: none"> ● Engine speed is about 2,000 rpm (More than 100 seconds after starting engine). 	<p>BATTERY VOLTAGE (11 - 14V)★</p>  <p>SEC991C</p>
111	GY/L	ECM relay (Self shut-off)	<p>[Engine is running] [Ignition switch: OFF]</p> <ul style="list-style-type: none"> ● For a few seconds after turning ignition switch OFF 	0 - 1.5V
			<p>[Ignition switch: OFF]</p> <ul style="list-style-type: none"> ● A few seconds passed after turning ignition switch OFF 	BATTERY VOLTAGE (11 - 14V)
119 120	R/W P	Power supply for ECM	[Ignition switch: ON]	BATTERY VOLTAGE (11 - 14V)

★: Average voltage for pulse signal (Actual pulse signal can be confirmed by oscilloscope.)

DTC P1572 ASCD BRAKE SWITCH

10. CHECK STOP LAMP SWITCH INPUT SIGNAL CIRCUIT FOR OPEN AND SHORT

1. Disconnect ECM harness connector.
2. Check harness continuity between ECM terminal 101 and stop lamp switch terminal 2.
Refer to Wiring Diagram.

Continuity should exist.

3. Also check harness for short to ground and short to power.

OK or NG

- OK >> GO TO 12.
NG >> GO TO 11.

11. DETECT MALFUNCTIONING PART

Check the following.

- Harness connectors E108, M15
- Harness connectors M72, F102
- Harness for open or short between ECM and stop lamp switch

>> Repair open circuit or short to ground or short to power in harness or connectors.

12. CHECK STOP LAMP SWITCH

Refer to [EC-522, "Component Inspection"](#)

OK or NG

- OK >> GO TO 13.
NG >> Replace stop lamp switch.

13. CHECK INTERMITTENT INCIDENT

Refer to [EC-127, "TROUBLE DIAGNOSIS FOR INTERMITTENT INCIDENT"](#) .

>> **INSPECTION END**

DTC P2122, P2123 APP SENSOR

2. CHECK APP SENSOR 1 POWER SUPPLY CIRCUIT

1. Disconnect accelerator pedal position (APP) sensor harness connector.
2. Turn ignition switch ON.

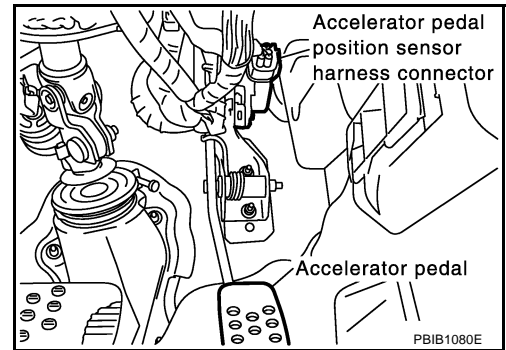

3. Check voltage between APP sensor terminal 6 and ground with CONSULT-II or tester.

Voltage: Approximately 5V

OK or NG

- OK >> GO TO 4.
NG >> GO TO 3.

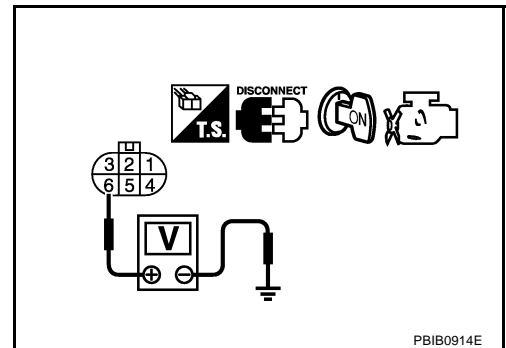

3. DETECT MALFUNCTIONING PART

Check the following.

- Harness connectors E11, F2
- Harness for open or short between ECM and accelerator pedal position sensor

>> Repair open circuit or short to ground or short to power in harness or connectors.

4. CHECK APP SENSOR 1 GROUND CIRCUIT FOR OPEN AND SHORT

1. Turn ignition switch OFF.
2. Disconnect ECM harness connector.
3. Check harness continuity between APP sensor terminal 3 and ECM terminal 82. Refer to Wiring Diagram.

Continuity should exist.

4. Also check harness for short to ground and short to power.

OK or NG

- OK >> GO TO 6.
NG >> GO TO 5.

5. DETECT MALFUNCTIONING PART

Check the following.

- Harness connectors E11, F2
- Harness for open or short between ECM and accelerator pedal position sensor

>> Repair open circuit or short to ground or short to power in harness or connectors.

IGNITION SIGNAL

EC-IGNSYS-02

: DETECTABLE LINE FOR DTC
 : NON-DETECTABLE LINE FOR DTC

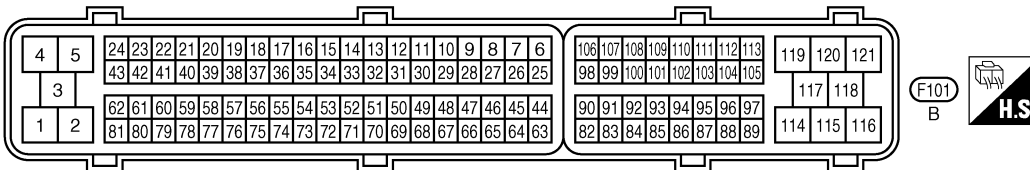
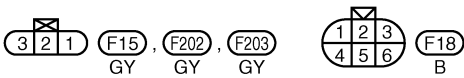
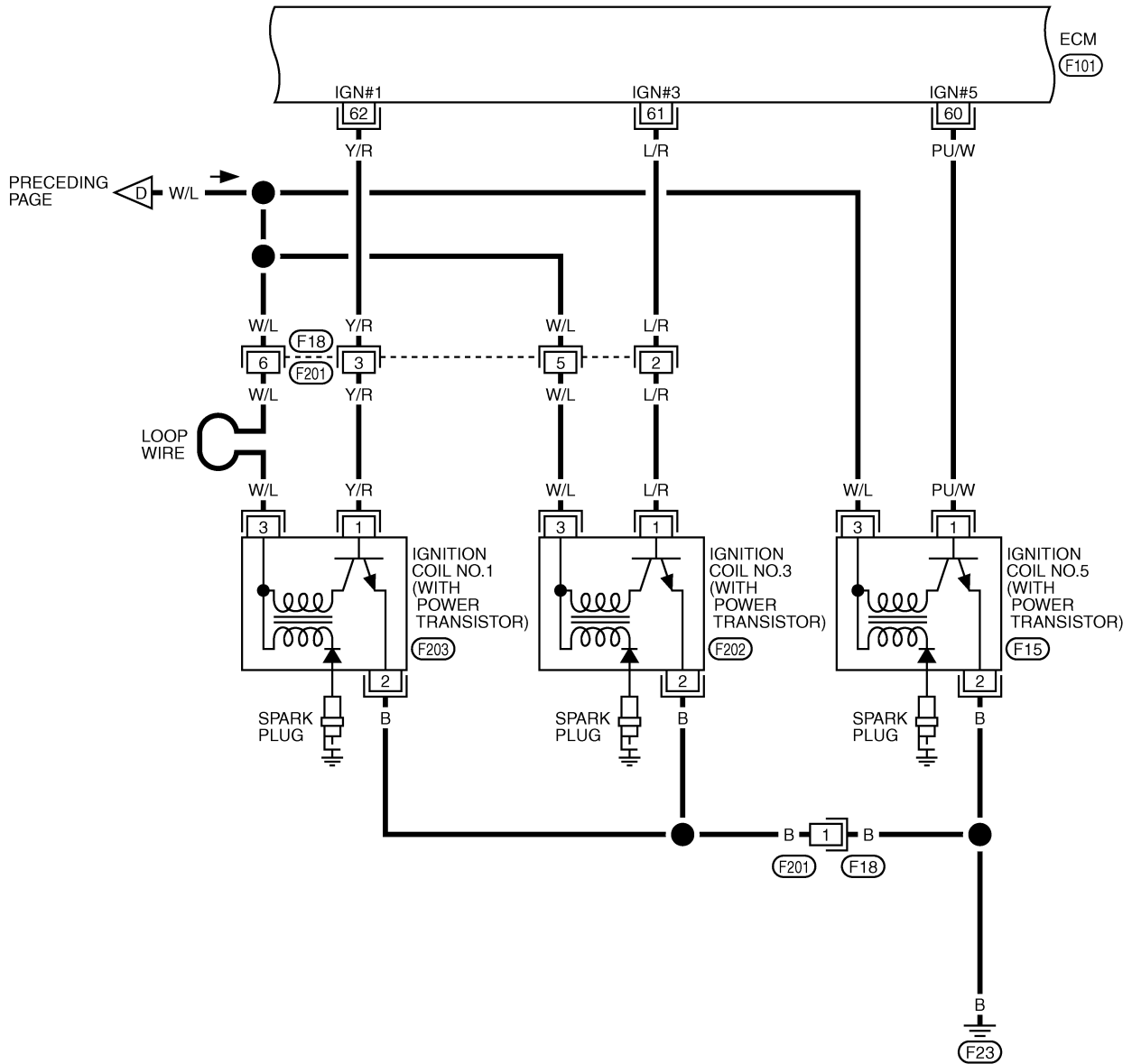

ASCD BRAKE SWITCH

ASCD BRAKE SWITCH

PFP:25320

Component Description

ABS0016J

When the brake pedal is depressed, ASCD brake switch is turned OFF and stop lamp switch is turned ON. ECM detects the state of the brake pedal by this input of two kinds (ON/OFF signal).

Refer to [EC-635, "AUTOMATIC SPEED CONTROL DEVICE \(ASCD\)"](#) for the ASCD function.

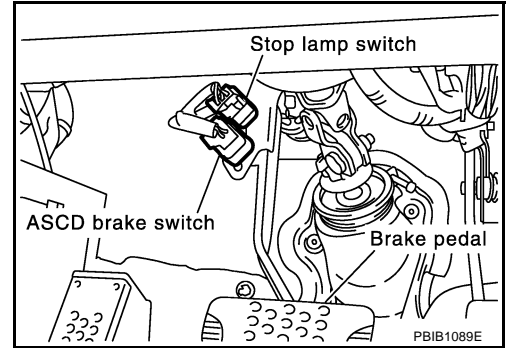

CONSULT-II Reference Value in Data Monitor Mode

ABS0016J

Specification data are reference values.

MONITOR ITEM	CONDITION		SPECIFICATION
BRAKE SW 1 (ASCD brake switch)	● Ignition switch: ON	● Clutch pedal (M/T) and brake pedal: Fully released	ON
		● Clutch pedal (M/T) and/or brake pedal: Slightly depressed	OFF
BRAKE SW 2 (stop lamp switch)	● Ignition switch: ON	● Brake pedal fully released	OFF
		● Brake pedal depressed	ON

ON BOARD REFUELING VAPOR RECOVERY (ORVR)

ON BOARD REFUELING VAPOR RECOVERY (ORVR)

PFP:00032

System Description

ABS0016V

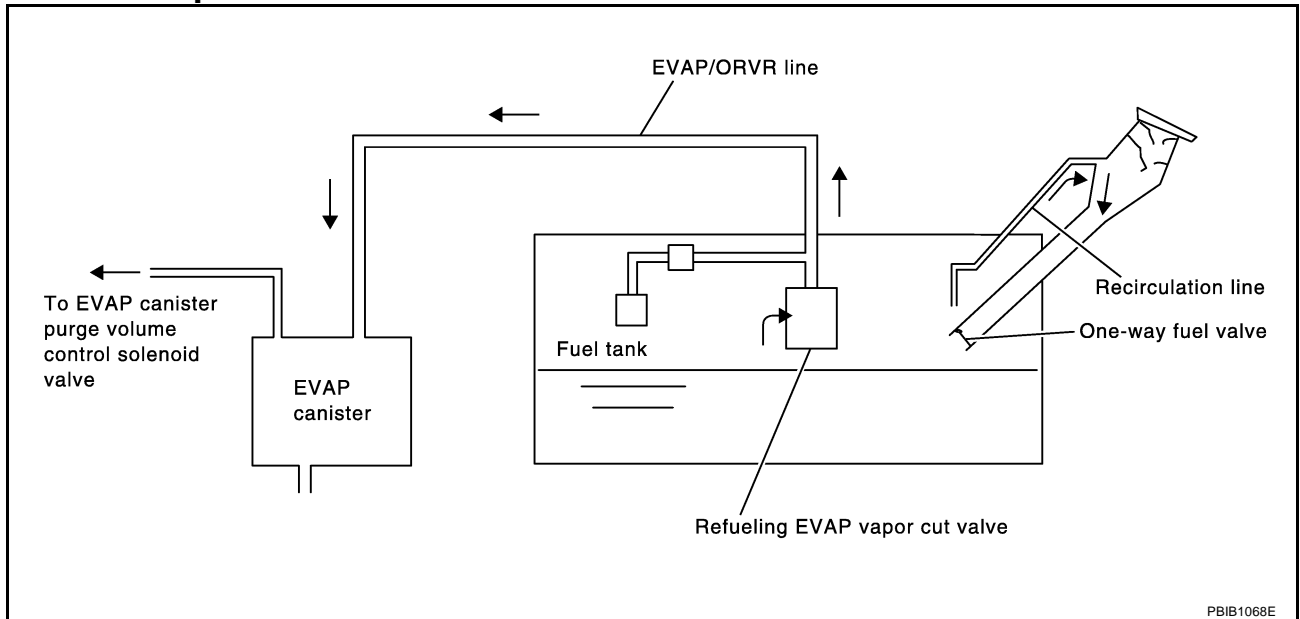

PBIB1068E

From the beginning of refueling, the air and vapor inside the fuel tank go through refueling EVAP vapor cut valve and EVAP/ORVR line to the EVAP canister. The vapor is absorbed by the EVAP canister and the air is released to the atmosphere.

When the refueling has reached the full level of the fuel tank, the refueling EVAP vapor cut valve is closed and refueling is stopped because of auto shut-off. The vapor which was absorbed by the EVAP canister is purged during driving.

WARNING:

When conducting inspections below, be sure to observe the following:

- Put a "CAUTION: INFLAMMABLE" sign in workshop.
- Do not smoke while servicing fuel system. Keep open flames and sparks away from work area.
- Be sure to furnish the workshop with a CO₂ fire extinguisher.

CAUTION:

- Before removing fuel line parts, carry out the following procedures:
 - Put drained fuel in an explosion-proof container and put lid on securely.
 - Release fuel pressure from fuel line. Refer to [EC-44, "FUEL PRESSURE RELEASE"](#).
 - Disconnect battery ground cable.
- Always replace O-ring when the fuel gauge retainer is removed.
- Do not kink or twist hose and tube when they are installed.
- Do not tighten hose and clamps excessively to avoid damaging hoses.
- After installation, run engine and check for fuel leaks at connection.
- Do not attempt to top off the fuel tank after the fuel pump nozzle shuts off automatically. Continued refueling may cause fuel overflow, resulting in fuel spray and possibly a fire.

REAR BUMPER

SEC. 850

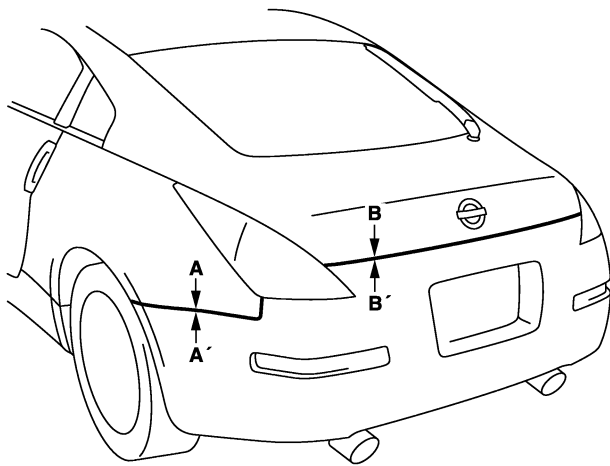
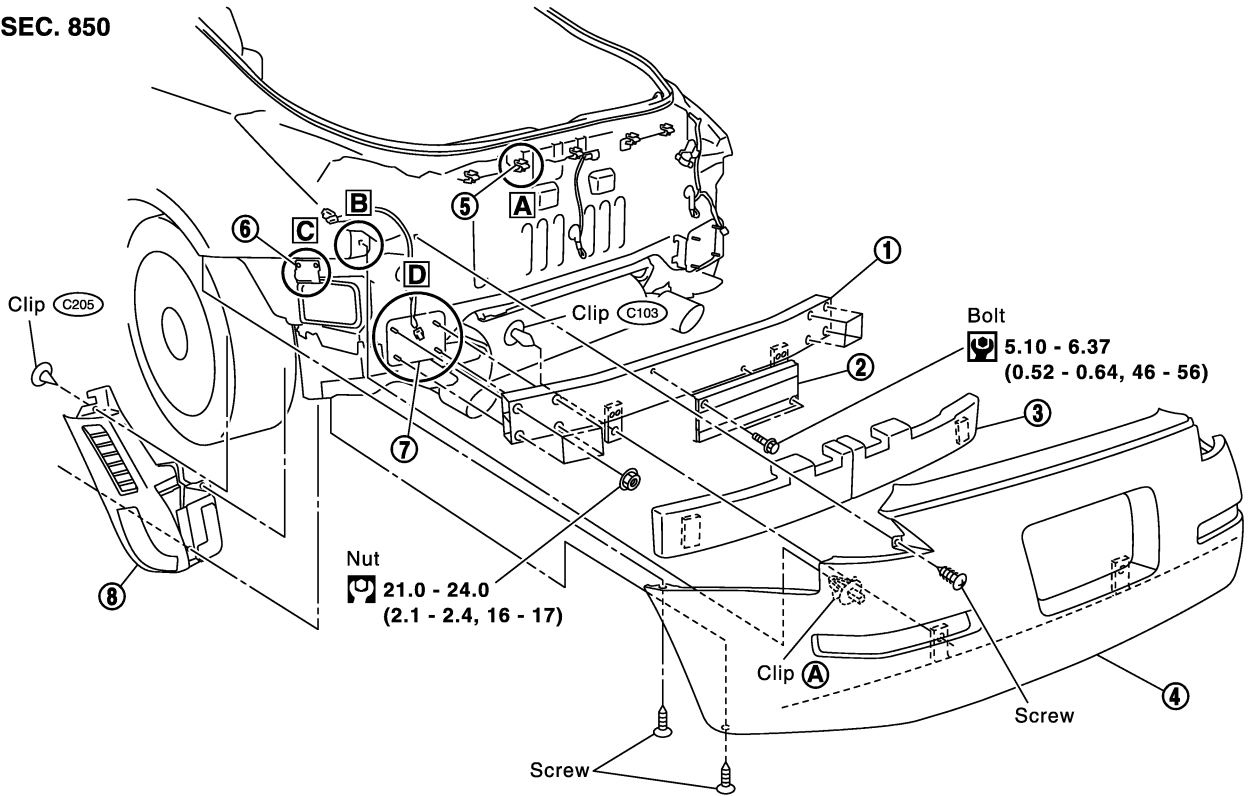

Clearance measurement
between parts
A - A': 0 - 0.50 (0 - 0.0197)
B - B': 3.9 - 7.10 (0.1535 - 0.2795)
Unit: mm (in)

: N•m (kg-m, in-lb)

: N•m (kg-m, ft-lb)

: Always replace after every disassembly.

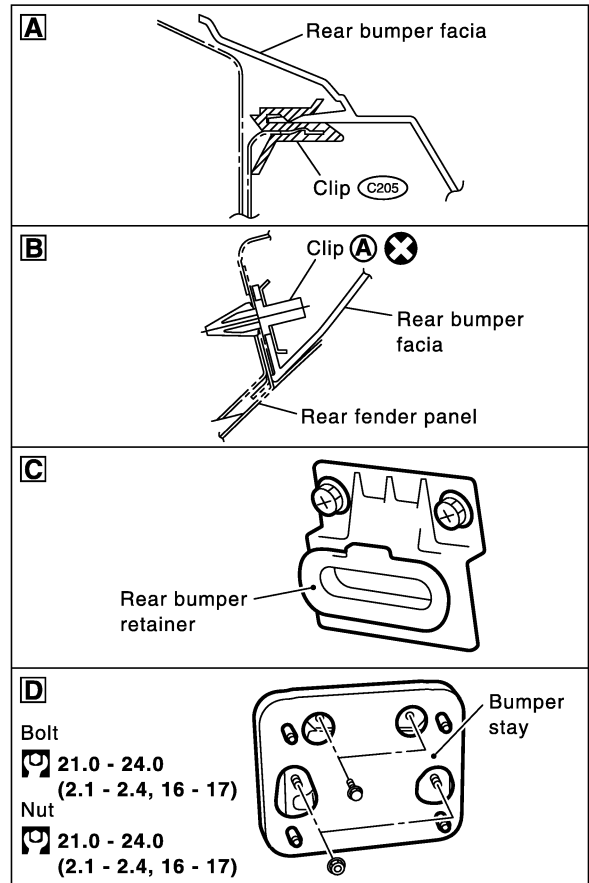



PIIA2134E

1. Bumper reinforcement

2. Bumper overrider

3. Energy absorber

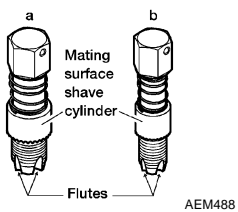
PREPARATION

(Kent-Moore No.) Tool name	Description
(J-43897-18) (J-43897-12) Oxygen sensor thread cleaner	 <p>Reconditioning the exhaust system threads before installing a new heated oxygen sensor (Use with anti-seize lubricant shown below.) a = J-43897-18 [18 mm (0.71 in) dia.] for zirconia heated oxygen sensor b = J-43897-12 [12 mm (0.47 in) dia.] for titania heated oxygen sensor</p>
Anti-seize lubricant (Permatex 133AR or equivalent meeting MIL specification MIL-A-907)	 <p>Lubricating heated oxygen sensor thread cleaning tool when reconditioning exhaust system threads</p>

FUEL INJECTOR AND FUEL TUBE

9. Connect quick connector between fuel feed hose and centralized under-floor piping connection with the following procedure:
 - a. Check the connection for damage and foreign materials.
 - b. Align the connector with the tube, then insert the connector straight into the tube until a click is heard.
 - c. After connecting the quick connector, use the following method to make sure it is full connected.
 - Visually confirm that the two retainer tabs are connected to the connector.
 - Pull the tube and the connector to make sure they are securely connected.
 - d. Install quick connector cap to quick connector connection.
 - Install quick connector cap with arrow on surface facing in direction of quick connector (fuel feed hose side).
- e. Secure fuel feed hose to clamp.
10. Install in the reverse order of removal after this step.

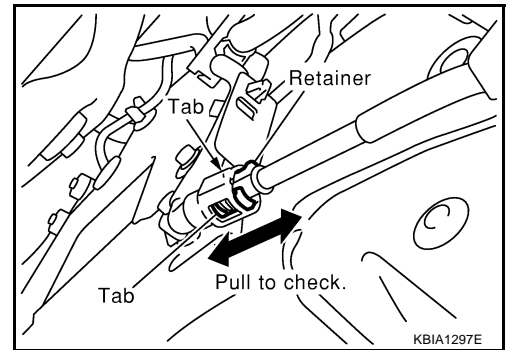

CAUTION:

If cap cannot be installed smoothly, quick connector may have not been installed correctly. Check connection again.

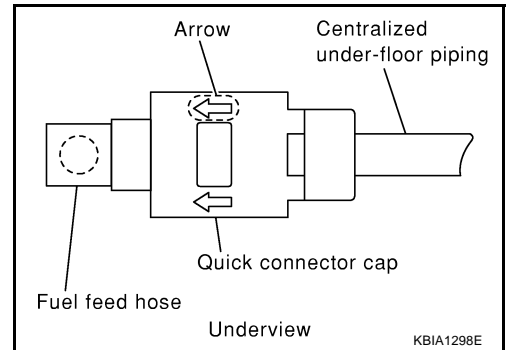

INSPECTION AFTER INSTALLATION

- Check for fuel leakage with following procedure.
 1. Turn ignition switch ON (do not start engine), and check connections for leakage by applying fuel pressure to fuel piping.
 2. Start engine, and re-check connections for fuel leakage by increasing engine speed.

CAMSHAFT

REMOVAL

1. Remove front timing chain case, camshaft sprocket, timing chain and rear timing chain case. Refer to [EM-49, "TIMING CHAIN"](#).
2. If necessary, remove camshaft position sensor (PHASE) (RH and LH banks) from cylinder head back side.

CAUTION:

- Handle carefully to avoid dropping and shocks.
- Do not disassemble.
- Do not allow metal powder to adhere to magnetic part at sensor tip.
- Do not place sensors in a location where they are exposed to magnetism.

Example: Left bank

Keep off any magnetic materials.

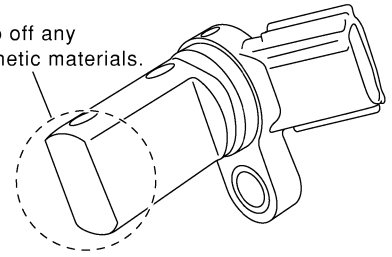

KBIA1046E

3. Remove intake valve timing control solenoid valve from No.1 camshaft bracket on both banks.

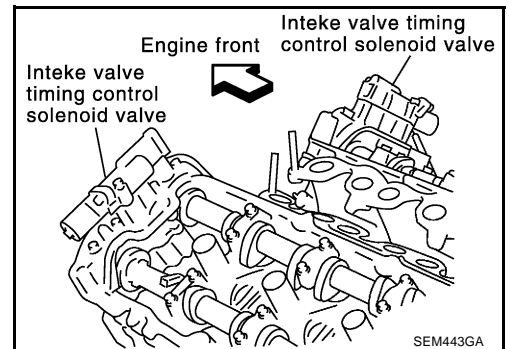

SEM443GA

4. Remove intake and exhaust camshaft brackets.
 - Mark camshafts, camshaft brackets, and bolts so they are placed in the same position and direction for installation.
 - Equally loosen the camshaft bracket bolts in several steps in the reverse order as shown.

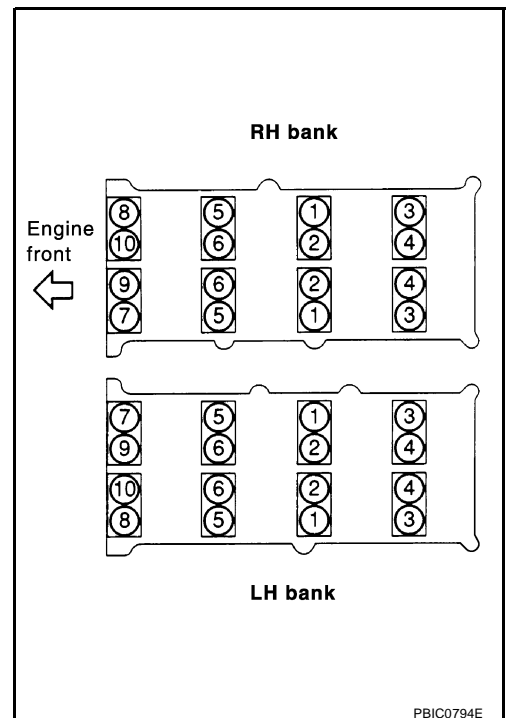

5. Remove camshaft.
6. Remove valve lifter.
 - Identify installation positions, and store them without mixing them up.

ENGINE ASSEMBLY

- Tighten rear engine mounting member mounting bolts in numerical order shown in the figure.

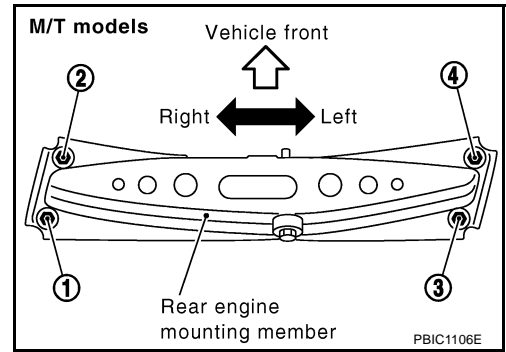

INSPECTION AFTER INSTALLATION

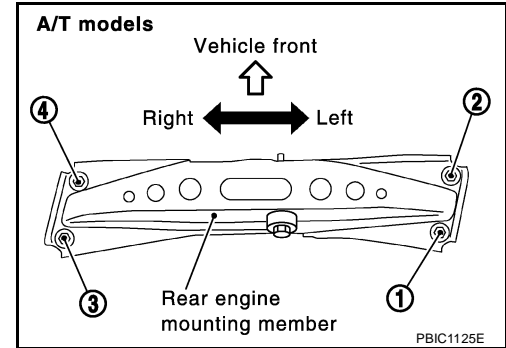

- Before starting engine, check the levels of engine coolant, lubrications and working oils. If less than required quantity, fill to the specified level.
- Use procedure below to check for fuel leakage.
 - Turn ignition switch ON (with engine stopped). With fuel pressure applied to fuel piping, check for fuel leakage at connection points.
 - Start engine. With engine speed increased, check again for fuel leakage at connection points.
- Run engine to check for unusual noise and vibration.
- Warm up engine thoroughly to make sure there is no leakage of engine coolant, engine oil, working fluid, fuel and exhaust gas.
- Bleed air from passages in pipes and tubes of applicable lines, such as in cooling system.
- After cooling down engine, again check amounts of engine coolant, engine oil and working fluid. Refill to specified level, if necessary.
- Summary of the Inspection items:

Item	Before starting engine	Engine running	After engine stopped
Engine coolant	Level	Leakage	Level
Engine oil	Level	Leakage	Level
Working fluid	Level	Leakage	Level
Fuel		Leakage	
Exhaust gas		Leakage	

SERVICE DATA AND SPECIFICATIONS (SDS)

DRIVE BELT

	Deflection adjustment		Unit: mm (in)	Tension adjustment*		Unit: N (kg, lb)
	Used belt		New belt	Used belt		New belt
	Limit	After adjustment		Limit	After adjustment	
Alternator and power steering oil pump belt	7 (0.28)	4 - 5 (0.16 - 0.20)	3.5 - 4.5 (0.138 - 0.177)	294 (30, 66)	730 - 818 (74.5 - 83.5, 164 - 184)	838 - 926 (85.5 - 94.5, 188 - 208)
Air conditioning compressor	12 (0.47)	9 - 10 (0.35 - 0.39)	8 - 9 (0.31 - 0.35)	196 (20, 44)	348 - 436 (35.5 - 44.5, 78 - 98)	470 - 559 (48 - 57, 106 - 126)
Applied pushing force	98 N (10 kg, 22 lb)			—		

SEC.117

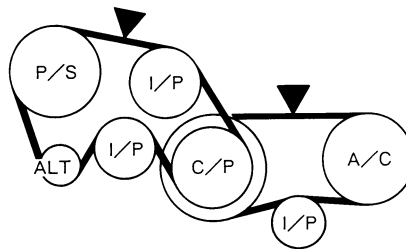

KBIA1731J

*: If belt tension gauge cannot be installed at check points shown, check drive belt tension at different location on the belt.

SPARK PLUG

Make	NGK
Standard type	PLFR5A-11
Hot type	PLFR4A-11
Cold type	PLFR6A-11
Gap (nominal)	1.1 mm (0.043 in)

CYLINDER HEAD

Unit: mm (in)

	Standard	Limit
Head surface distortion	—	0.1 (0.004)
Normal cylinder head height "H"	126.3 - 126.5 (4.972 - 4.980)	—

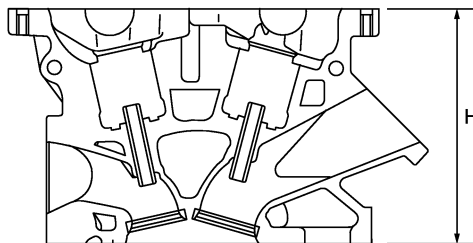

PBIC0924E

PRECAUTIONS

PRECAUTIONS

PFP:00001

Precautions for Battery Service

ABS00DCW

Before disconnecting the battery, lower both the driver and passenger windows. This will prevent any interference between the window edge and the vehicle when the door is opened/closed. During normal operation, the window slightly raises and lowers automatically to prevent any window to vehicle interference. The automatic window function will not work with the battery disconnected.

COMPRESSION ROD

PFP:54468

AES00032

COMPRESSION ROD

Removal and Installation

REMOVAL

1. Remove tire with power tool.
2. Remove undercover with power tool.
3. Remove front cross bar from vehicle with power tool.
4. Remove cotter pin of compression rod ball joint, and loosen nut.
5. Use a ball joint remover (suitable tool) to remove compression rod from steering knuckle. Be careful not to damage ball joint boot.

CAUTION:

Tighten temporarily mounting nut to prevent damage to threads and to prevent ball joint remover (suitable tool) from coming off.

6. Remove compression rod from vehicle.

INSPECTION AFTER REMOVAL

Visual Inspection

- Check compression rod and bushing for deformation, cracks, or damage. If any non-standard condition is found, replace it.
- Check boot of ball joint for cracks, or other damage, and also for grease leakage. If any non-standard condition is found, replace it.

Ball Joint Inspection

- Manually move ball stud to confirm it moves smoothly with no binding.

Swing Torque Inspection

NOTE:

Before measurement, move ball joint at least ten times by hand to check for smooth movement.

- Hook spring scale at ball stud. Confirm spring scale measurement value is within the specifications when ball stud begins moving.

Standard value

Swing torque:

0.147 - 2.45 N·m (0.02 - 0.24 kg·m, 2 - 21 in·lb)

Measured value of spring scale:

2.37 - 39.5 N (0.24 - 4.03 kg, 0.53 - 8.88 lb)

- If it is outside the specified range, replace compression rod assembly.

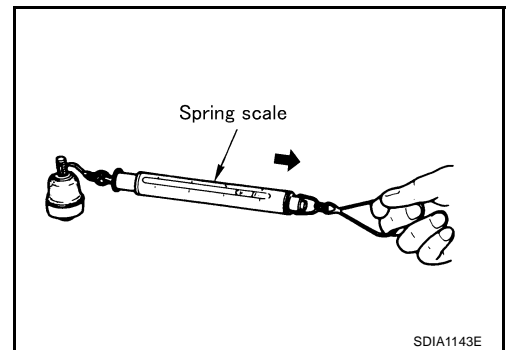

Rotating Torque Inspection

- Attach mounting nut to ball stud. Check that sliding torque is within the specifications with a preload gauge (SST).

Standard value

Rotating torque:

0.147 - 2.45 N·m (0.02 - 0.24 kg·m, 2 - 21 in·lb)

- If it is outside the specified range, replace compression rod assembly.

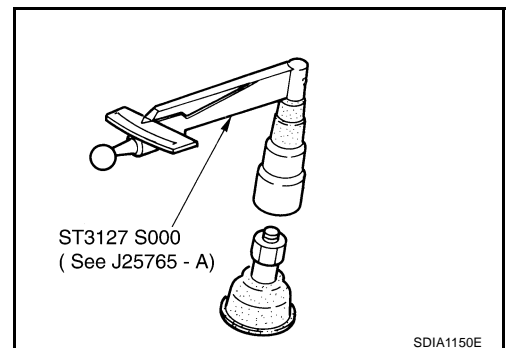

HOW TO USE THIS MANUAL

Reference Area

The Reference Area of the wiring diagram contains references to additional electrical reference pages at the end of the manual. If connector numbers and titles are shown in the Reference Area of the wiring diagram, these connector symbols are not shown in the Connector Area.

Example

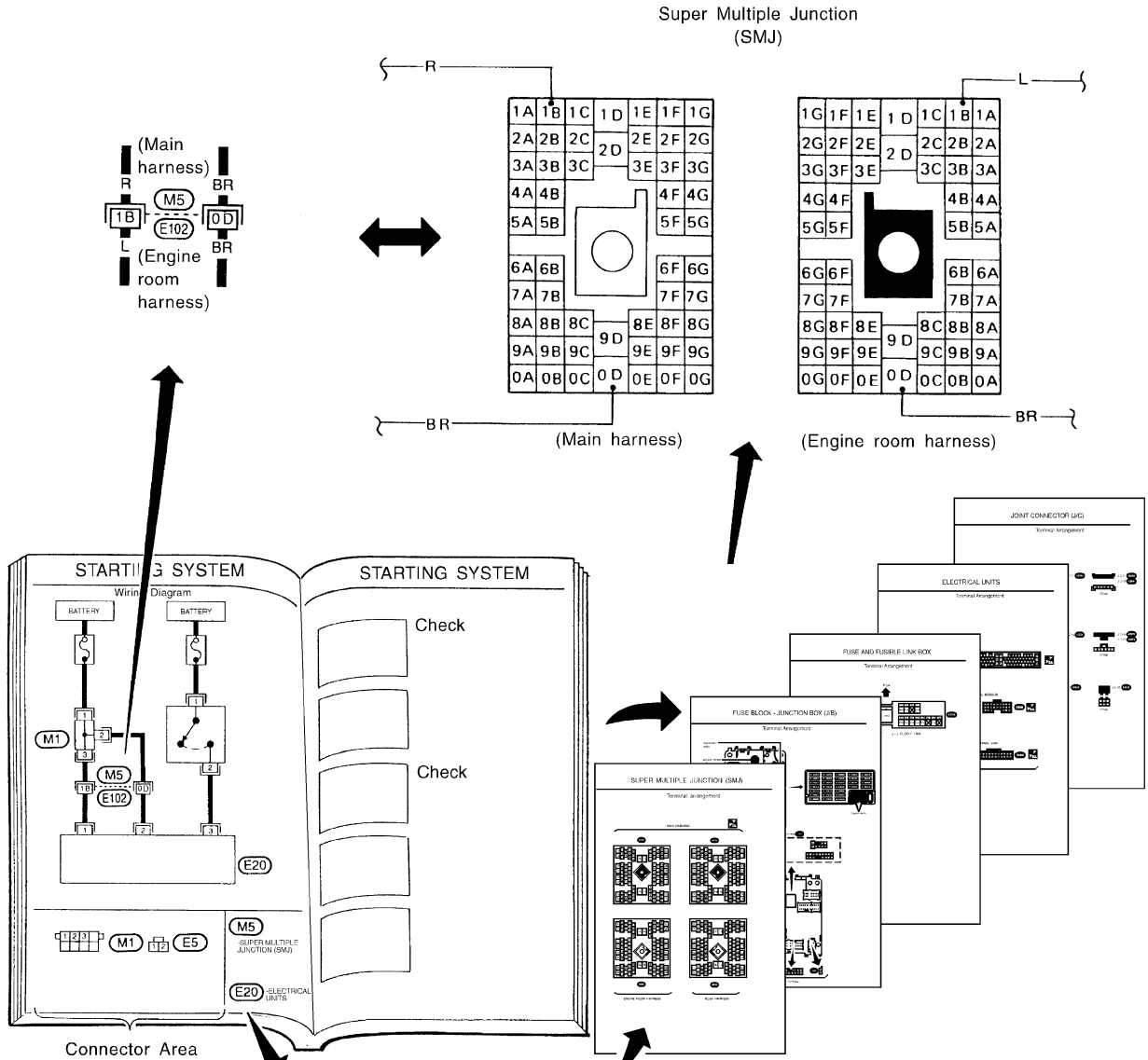

Reference Area:
Refer to the electrical reference pages at the end of the manual for the terminal arrangement of the connectors shown here in the "Reference Area".

SGI092A

IDENTIFICATION INFORMATION

ENGINE SERIAL NUMBER

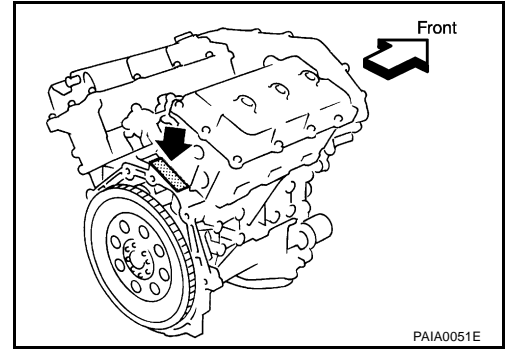

AUTOMATIC TRANSMISSION NUMBER

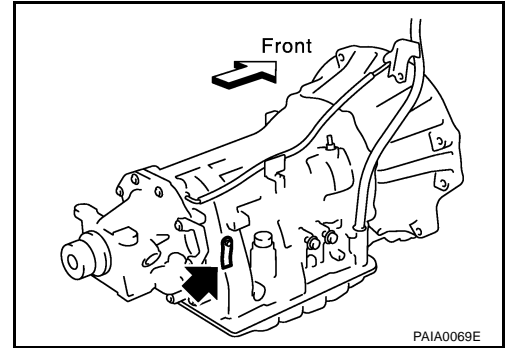

MANUAL TRANSMISSION NUMBER

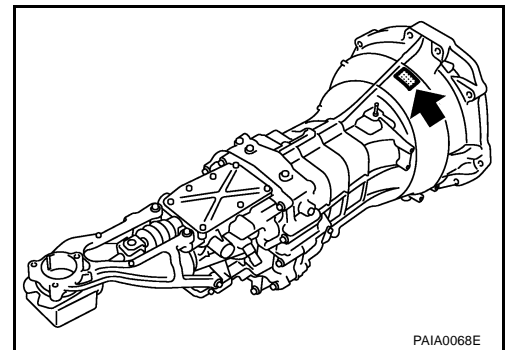

Dimensions

AAS0002D

Unit: mm (in)

Overall length	4,309 (169.6)
Overall width	1,815 (71.5)
Overall height	1,328 (52.3)
Front tread	1,535 (60.4)
Rear tread	1,539 (60.6)*1, 1,545 (60.8)*2
Wheelbase	2,649 (104.3)

*1: The wheel offset is 1.30 in (33 mm).

*2: The wheel offset is 1.18 in (30 mm).

POWER WINDOW SYSTEM

Terminal and Reference Value for BCM

AIS000FC

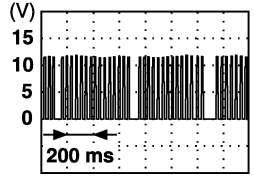
TERMINAL	WIRE COLOR	ITEM	CONDITION	VOLTAGE (V) (Approx.)
7	R	BAT power supply	—	Battery voltage
8	B	Ground	—	0
10	P	Passenger side door switch	ON (open)	0
			OFF (closed)	5
14	W	Driver side door switch	ON (open)	0
			OFF (closed)	5
28	W	Power window switch power supply	—	Battery voltage
29	Y/B	Rap signal	IGN SW ON	Battery voltage
			More then 45 second after ignition switch is turned to OFF	0
			When driver side door is open, (IGN OFF)	0
35	W/L	Ignition switch ON or START	Ignition switch (ON or START position)	Battery voltage
36	LG	Ignition switch ACC or ON	Ignition switch (ACC or ON position)	Battery voltage
74	Y	Power window serial link	—	 <p style="text-align: right; font-size: small;">PIIA2344J</p>

Terminal and Reference Value for Power Window Main Switch

AIS000FD

TERMINAL	WIRE COLOR	ITEM	CONDITION	VOLTAGE (V) (ApproX.)
1	W	BAT power supply	—	Battery voltage
4	BR	Power window down request signal	When soft top open/close function starts and window down function is operating.	0
			Except the above	5
5	W	Encoder power supply	—	10
6	R	Key cylinder switch lock	Key position (Neutral → Locked)	5 → 0
7	SB	Key cylinder switch unlock	Key position (Neutral → Unlocked)	5 → 0
8	L	Driver side power window motor UP signal	When power window motor UP operation.	Battery voltage
9	Y	Limit switch signal	Driver side door window is between fully-open and just before fully-closed position (ON).	0
			Driver side door window is between just before fully-closed position and fully-closed position (OFF).	5

FRONT DOOR GLASS AND REGULATOR

5. Remove mounting bolts, and remove module assembly.
6. Disconnect harness connector for module assembly, and unclip harness from the back.

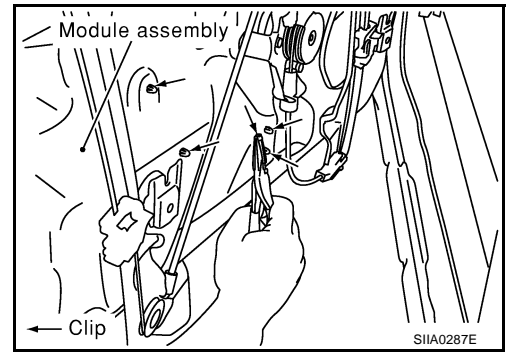

INSTALLATION

Install in the reverse order of removal.

INSPECTION AFTER REMOVAL

Check regulator assembly for the following items. If a malfunction is detected, replace or grease it.

- Wire wear
- Regulator deformation
- Grease condition for each sliding part

The arrows in the figure show the application points of body grease.

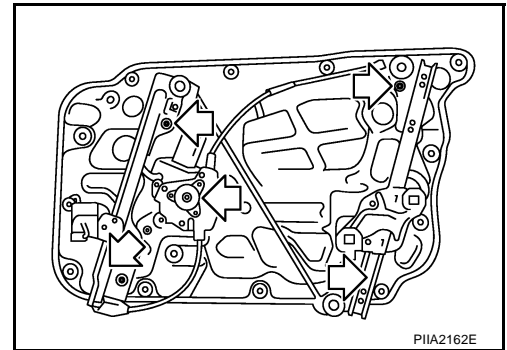

DISASSEMBLY AND ASSEMBLY

Remove power window motor and guide rail from module assembly.

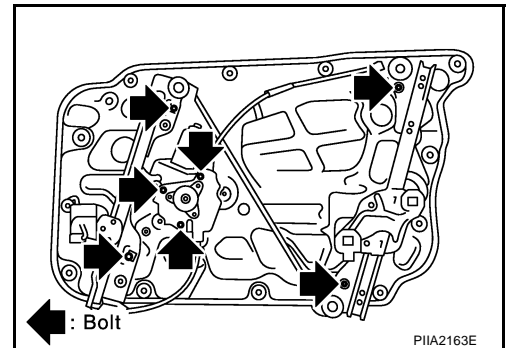

ALPHABETICAL INDEX

Numerics	
3METER - Wiring diagram	DI-39
A	
A/C component layout	ATC-23
A/C compressor mounting	ATC-130
A/C compressor precaution	ATC-11
A/C compressor special service tool	ATC-15
A/C controller	ATC-107
A/C diagnostic work flow (auto A/C)	ATC-96
A/C evaporator	ATC-143
A/C HFC134a (R134a) system precaution	ATC-5
A/C HFC134a (R134a) system service procedure	ATC-128
A/C HFC134a (R134a) system service tools ...	ATC-16
A/C HFC134a system service equipment precaution ...	ATC-12
A/C lubricant (R134a)	ATC-24
A/C lubrication oil	ATC-149
A/C operational check	ATC-57
A/C self-diagnoses (auto A/C)	ATC-49 , ATC-96
A/C service data specification	ATC-149
A/C trouble diagnoses (auto A/C)	ATC-36
A/C, A - Wiring diagram	ATC-42
A/T fluid checking	AT-12 , AT-50
A/T fluid replacement	AT-12
A/T fluid temperature sensor	AT-134
A/T IND - Wiring diagram	DI-77
A/T self-diagnoses	AT-97
A/T shift lock system	AT-230
A/T shift lock system - Wiring diagram	AT-231
A/T trouble diagnoses	AT-41
A/T Wiring diagram AT - CAN	AT-100
A/T Wiring diagram AT - FTS	AT-135
A/T Wiring diagram AT - MMSW	AT-169
A/T Wiring diagram AT - NONDTC	AT-184
A/T Wiring diagram AT - PNP/SW	AT-107
A/T Wiring diagram AT - POWER	AT-124
A/T Wiring diagram AT - STSIG	AT-103
A/T Wiring diagram AT - VSS A/T	AT-112
Accelerator control system	ACC-3
Accelerator pedal position (APP) sensor	EC-540 , EC-547 , EC-561
Accelerator pedal released position learning	EC-42
Air bag	SRS-3
Air bag disposal	SRS-46
Air bag precautions	SRS-3
Air bleeding (hydraulic clutch)	CL-7
Air bleeding for brake system	BR-10
Air cleaner and air duct	EM-15
Air cleaner filter replacement	MA-17
Air conditioner cut control	EC-28
Air flow meter - See Mass air flow sensor	EC-157 , EC-165
Air mix. door motor	ATC-68 , ATC-122
Ambient sensor	ATC-97 , ATC-109
Angular tightening application	EM-4
Antenna	AV-34
APPS1 - Wiring diagram	EC-542
APPS2 - Wiring diagram	EC-549
APPS3 - Wiring diagram	EC-563
ASC/BS - Wiring diagram	EC-509
ASC/SW - Wiring diagram	EC-502
ASCBOF - Wiring diagram	EC-601
ASCD	EC-635
ASCD (automatic speed control device)	ACS-2
ASCIND - Wiring diagram	EC-617
Ashtray illumination	LT-115
AT indicator lamp	DI-77
Audio	AV-5
AUDIO - Wiring diagram	AV-9
Auto air conditioner - Wiring diagram	ATC-42
Auto amp	ATC-108
Auto anti-dazzling inside mirror	GW-52
Automatic amplifier	ATC-59 , ATC-108
Automatic transmission fluid replacement	MA-25
Axle	MA-30
Axle housing (rear)	RAX-8
B	
BACK/L - Wiring diagram	LT-92
Back-up lamp	LT-92
Back-up lamp switch (M/T)	MT-12
Battery	SC-4
Battery/Starting/Charging System Tester	SC-6 , SC-15 , SC-23
BCM (Body control module)	BCS-3
Blower motor	ATC-75 , ATC-115
Blower unit	ATC-113
Bose speaker amp.	AV-5
Brake booster	BR-17
Brake fluid change	BR-9
Brake fluid level	MA-28
Brake fluid level and line check	BR-9
Brake hydraulic line	BR-11
Brake inspection	MA-28
Brake lines and cables inspection	MA-28
Brake master cylinder	BR-13
Brake pedal	BR-6
Brake switch	EC-534
BRK/SW - Wiring diagram	EC-535
Bulb specifications	LT-142
Bumper, front	EI-14
Bumper, rear	EI-17
C	
Camshaft	EM-65
Camshaft inspection	EM-67
Camshaft position sensor (PHASE)	EC-299
CAN - Wiring diagram	EC-136 , LAN-9 , LAN-36
CAN (Controller Area Network)	LAN-4 , LAN-8 , LAN-35
CAN communication ...	EC-29 , EC-135 , AT-30 , AT-99 , LT-8 , LT-59 , LT-96 , LT-132 , WW-9 , LAN-4 , LAN-8 , LAN-35

CAN COMMUNICATION

[CAN]

Signals	ECM	TCM	Unified meter and A/C amp.	BCM	ABS actuator and electric unit (control unit)	IPDM E/R	
ABS operation signal		R			T		A
A/T shift schedule change demand signal		R			T		B
A/C switch signal	R			T			C
A/C compressor request signal	T					R	
A/C compressor feedback signal	T		R				D
Blower fan motor switch signal	R			T			
Cooling fan speed request signal	T					R	
Position lights request signal			R	T		R	E
Low beam request signal				T		R	
Low beam status signal	R					T	
High beam request signal			R	T		R	F
High beam status signal	R					T	
Vehicle speed signal			R		T		
	R	R	T	R			G
Sleep request 1 signal			R	T			
Sleep request 2 signal				T		R	H
Wake up request 1 signal			R	T			
Door switch signal			R	T		R	
Turn indicator signal			R	T			I
Seat belt buckle switch signal			T	R			
Buzzer output signal			R	T			J
Fuel level sensor signal	R		T				
Malfunction indicator lamp signal	T		R				
ASCD SET lamp signal	T		R				LAN
ASCD operation signal	T	R					
ASCD CRUISE lamp signal	T		R				L
ASCD OD cancel request signal	T	R					
Output shaft revolution signal	R	T					
Turbine revolution signal	R	T					M
Front wiper request signal				T		R	
Front wiper stop position signal				R		T	
Rear window defogger switch signal				T		R	
Rear window defogger control signal	R					T	
Manual mode signal		R	T				
Not manual mode signal		R	T				
Manual mode shift up signal		R	T				
Manual mode shift down signal		R	T				
Manual mode indicator signal		T	R				
Hood switch signal				R		T	
Theft warning horn request signal				T		R	
Horn chirp signal				T		R	
ABS warning lamp signal			R		T		

4. CHECK HARNESS FOR SHORT CIRCUIT

1. Disconnect following connectors.
 - Unified meter and A/C amp. connector
 - BCM connector
 - Harness connector M15
2. Check continuity between data link connector M8 terminals 6 (L) and 14 (R).

6 (L) – 14 (R) : Continuity should not exist.

OK or NG

OK >> GO TO 5.

NG >> Check the following harnesses. If any harness is damaged, repair the harness.

- Harness between data link connector and harness connector M72
- Harness between data link connector and unified meter and A/C amp.
- Harness between data link connector and BCM
- Harness between data link connector and harness connector M15

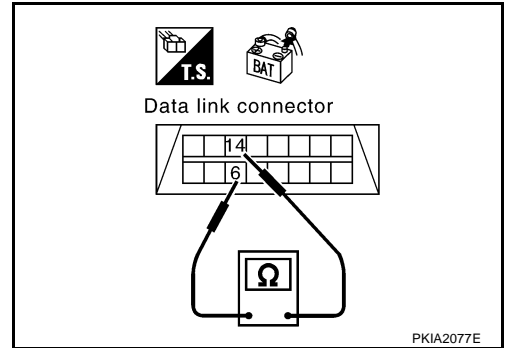

5. CHECK HARNESS FOR SHORT CIRCUIT

Check continuity between data link connector M8 terminals 6 (L), 14 (R) and ground.

6 (L) – ground : Continuity should not exist.

14 (R) – ground : Continuity should not exist.

OK or NG

OK >> GO TO 6.

NG >> Check the following harnesses. If any harness is damaged, repair the harness.

- Harness between data link connector and harness connector M72
- Harness between data link connector and unified meter and A/C amp.
- Harness between data link connector and BCM
- Harness between data link connector and harness connector M15

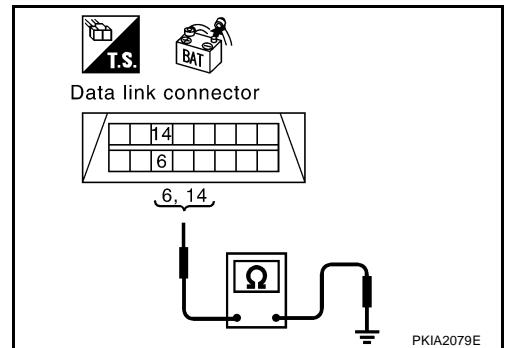

6. CHECK HARNESS FOR SHORT CIRCUIT

1. Disconnect ABS actuator and electric unit (control unit) connector and IPDM E/R connector.
2. Check continuity between IPDM E/R harness connector E9 terminals 48 (L) and 49 (R).

48 (L) – 49 (R) : Continuity should not exist.

OK or NG

OK >> GO TO 7.

NG >> Check the following harnesses. If any harness is damaged, repair the harness.

- Harness between IPDM E/R and ABS actuator and electric unit (control unit)
- Harness between IPDM E/R and harness connector E108

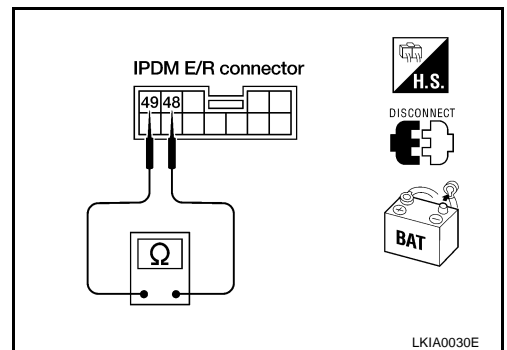

REMOVAL AND INSTALLATION	108	Wiring Diagram — ROOM/L —	120	
Tail Lamp	108	Terminals and Reference Value for BCM	123	A
BULB REPLACEMENT	108	How to Proceed With Trouble Diagnosis	123	
REMOVAL AND INSTALLATION	108	Preliminary Check	124	
REAR COMBINATION LAMP	109	INSPECTION FOR POWER SUPPLY AND		B
Bulb Replacement	109	GROUND CIRCUIT	124	
REAR FENDER SIDE (STOP & TAIL LAMP		CONSULT-II Function	125	
BULB, REAR SIDE MARKER LAMP BULB)	109	CONSULT-II BASIC OPERATION	125	C
REAR BUMPER SIDE (BACK-UP LAMP BULB,		WORK SUPPORT	126	
REAR TURN SIGNAL LAMP BULB)	109	DATA MONITOR	126	
Removal and Installation	110	ACTIVE TEST	127	D
REMOVAL	110	Map Lamp Control Does Not Operate	127	
INSTALLATION	110	Map Lamp Illumination Does Not Operate	129	E
VANITY MIRROR LAMP	111	Bulb Replacement	130	
Bulb Replacement	111	Removal and Installation	130	
TRUNK ROOM LAMP	112	REMOVAL	130	
Wiring Diagram — INT/L —	112	INSTALLATION	130	F
Bulb Replacement, Removal and Installation of		ILLUMINATION	131	
Trunk Room Lamp	113	System Description	131	
REAR FLOOR BOX LAMP	114	ILLUMINATION OPERATION BY LIGHTING		G
Bulb Replacement, Removal and Installation	114	SWITCH	131	
ASHTRAY ILLUMINATION	115	EXTERIOR LAMP BATTERY SAVER CONTROL	131	
Bulb Replacement, Removal and Installation	115	CAN Communication System Description	132	H
INTERIOR ROOM LAMP	116	CAN Communication Unit	132	
System Description	116	Schematic	133	
POWER SUPPLY AND GROUND	116	Wiring Diagram — ILL —	134	I
SWITCH OPERATION	117	BULB SPECIFICATIONS	142	
SPOT LAMP TIMER OPERATION	117	Headlamp	142	J
INTERIOR LAMP BATTERY SAVER CONTROL	118	Exterior Lamp	142	
Component Parts and Harness Connector Location	118	Interior Lamp/Illumination	142	
Schematic	119			

LT

L

M

HEADLAMP (FOR CANADA) - DAYTIME LIGHT SYSTEM -

EXTERIOR LAMP BATTERY SAVER CONTROL

When the combination switch (lighting switch) is in the 2ND position (ON), and the ignition switch is turned from ON or ACC to OFF, the battery saver control function is activated.

Under this condition, the headlamps remain illuminated for 5 minutes, then the headlamps are turned off. Exterior lamp battery saver control mode can be changed by the function setting of CONSULT-II.

DAYTIME LIGHT OPERATION

With the engine running, the lighting switch in the OFF or 1ST position and parking brake released, power is supplied

- through daytime light control unit terminal 7
- to front combination lamp LH terminal 3
- through front combination lamp LH terminal 4
- to daytime light control unit terminal 9
- through daytime light control unit terminal 6
- to front combination lamp RH terminal 3.

Ground is supplied

- to front combination lamp RH terminal 4
- through grounds E17, E43 and F152, and
- to daytime light control unit terminal 14
- through grounds E17, E43 and F152.

Because the high beam headlamps are now wired in series, they operate at half illumination.

If the lighting switch is in the HIGH position, daytime light operation is canceled. On this occasion, power is supplied

- through IPDM E/R terminal 21
- to daytime light control unit terminal 2

Daytime light control unit is canceled power supplying from front combination lamp RH terminal 7 to terminal 8 (series power supplying is canceled). And then low beam is ON.

OPERATION

After starting the engine with the lighting switch in the "OFF" or 1ST position, the headlamp high beam automatically turns on. Lighting switch operations other than the above are the same as conventional light systems.

Engine		With engine stopped									With engine running								
		OFF			1ST			2ND			OFF			1ST			2ND		
		Hi	Lo	P	Hi	Lo	P	Hi	Lo	P	Hi	Lo	P	Hi	Lo	P	Hi	Lo	P
Head-lamp	High beam	-	-	-	-	-	×	×	-	×	●*	●*	×	●*	●*	×	×	-	×
	Low beam	-	-	-	-	-	×	×	×	×	-	-	×	-	-	×	×	×	×
Tail lamp		-	-	-	×	×	×	×	×	×	-	-	-	×	×	×	×	×	×
License and instrument illumination lamp		-	-	-	×	×	×	×	×	×	-	-	-	×	×	×	×	×	×

- Hi: "HIGH BEAM" position
- Lo: "LOW BEAM" position
- P: "FLASH TO PASS" position
- ×: Lamp "ON"
- -: Lamp "OFF"
- ●: Lamp dims. (Added functions)
- *: When starting the engine with the parking brake released, the daytime light will come ON.
When starting the engine with the parking brake pulled, the daytime light will not come ON.

TURN SIGNAL AND HAZARD WARNING LAMPS

Ground is supplied

- to front combination lamp LH terminal 1
- through grounds E17, E43 and F152
- to front combination lamp RH terminal 1
- through grounds E17, E43 and F152
- to rear combination lamp LH terminal 4
- through grounds T14, B6 and B5
- to rear combination lamp RH terminal 4
- through grounds T14, B6 and B5.

The BCM also supplies input signal to combination meter terminals 27 and 28 across the CAN communication lines. This input is processed by the unified meter control unit in the combination meter through the unified meter and A/C amp., which in turn supplies ground to the left and right turn signal indicator lamps.

With power and ground supplied, the BCM controls the flashing of the hazard warning lamps when key fob is used to activate the remote keyless entry system.

COMBINATION SWITCH READING FUNCTION

Refer to [LT-76, "Combination Switch Reading Function"](#) .

CAN Communication System Description

AKS003N5

CAN (Controller Area Network) is a serial communication line for real time application. It is an on-vehicle multiplex communication line with high data communication speed and excellent error detection ability. Many electronic control units are equipped onto a vehicle, and each control unit shares information and links with other control units during operation (not independent). In CAN communication, control units are connected with 2 communication lines (CAN H line, CAN L line) allowing a high rate of information transmission with less wiring. Each control unit transmits/receives data but selectively reads required data only.

CAN Communication Unit

AKS003N6

Refer to [LAN-4, "CAN Communication Unit"](#) .

A

B

C

D

E

F

G

H

I

J

LT

L

M

COMBINATION SWITCH

2. HARNESS INSPECTION

1. Disconnect BCM connector and combination switch connector.
2. Check continuity between BCM harness connector of Malfunctioning system and ground.

Malfunctioning system	Terminals			Continuity
	BCM		Ground	
	Connector	Terminal (wire color)		
1	M2	Input 1	48 (W/R)	No
		Output 1	47 (Y/G)	
2		Input 2	49 (W/G)	
		Output 2	40 (Y/R)	
3		Input 3	50 (W/L)	
		Output 3	41 (PU/W)	
4		Input 4	51 (G)	
		Output 4	42 (L/W)	
5		Input 5	52 (G/B)	
		Output 5	43 (GY)	

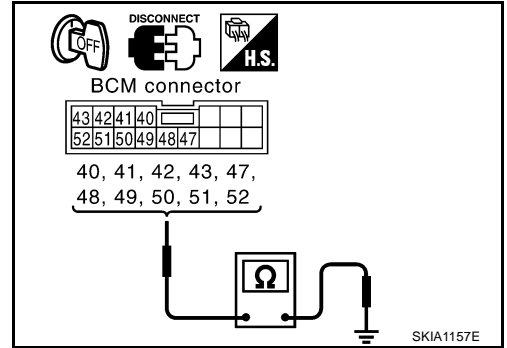

OK or NG

- OK >> GO TO 3.
 NG >> Repair harness.

3. INSPECTION OF BCM INPUT TERMINAL VOLTAGE

Connect BCM connector. Check voltage between BCM input terminal of applicable malfunctioning system and ground.

Malfunctioning system	Terminals			Voltage
	BCM (+)		(-)	
	Connector	Terminal (wire color)		
1	M2	48 (W/R)	Ground	4.5V or more
2		49 (W/G)		
3		50 (W/L)		
4		51 (G)		
5		52 (G/B)		

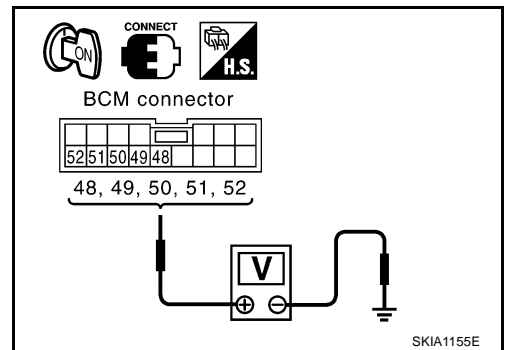

OK or NG

- OK >> Combination switch malfunction, go to 4.
 NG >> Replace BCM.

4. COMBINATION SWITCH INSPECTION

Following the table below, check combination switch.

Procedure									
1	2		3	4		5	6		7
Lighting switch replacement	Confirm self-diagnostic results again.	OK	Inspection End	Confirm self-diagnostic results again.	OK	Inspection End	Confirm self-diagnostic results again.	OK	Inspection End
		NG	Wiper switch replacement		NG	Replacement of switch base		NG	Confirm symptom again.

>> Inspection End

ASHTRAY ILLUMINATION

ASHTRAY ILLUMINATION

PFP:25860

Bulb Replacement, Removal and Installation

AKS000VY

1. Remove center console assembly. Refer to [IP-10, "INSTRUMENT PANEL ASSEMBLY"](#) in "IP" section.
2. Turn bulb socket counterclockwise to undo lock and remove bulb socket.

Ashtray illumination : 12V - 1.4W

3. Install in the reverse order of removal.

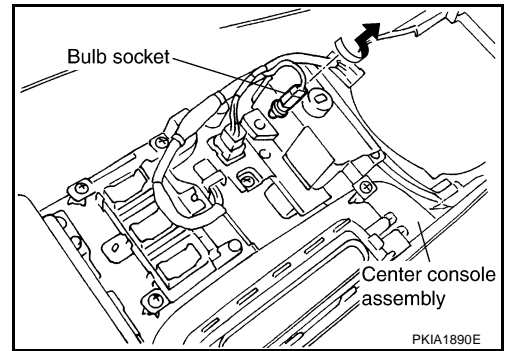

A
B
C
D
E
F
G
H
I
J
LT
L
M

A
LU
C

SECTION LU

ENGINE LUBRICATION SYSTEM

CONTENTS

PRECAUTIONS		OIL COOLER	10	
Precautions for Liquid Gasket	2	Removal and Installation	10	F
LIQUID GASKET APPLICATION PROCEDURE....	2	REMOVAL	10	G
PREPARATION	3	INSPECTION AFTER REMOVAL	10	H
Special Service Tools	3	INSTALLATION	11	I
Commercial Service Tools	3	INSPECTION AFTER INSTALLATION	11	J
LUBRICATION SYSTEM	4	OIL PUMP	12	K
Lubrication Circuit	4	Removal and Installation	12	L
System Drawing	5	REMOVAL	12	M
ENGINE OIL	6	INSTALLATION	12	
Inspection	6	INSPECTION AFTERT INSTALLATION	12	
OIL LEVEL	6	Disassembly and Assembly	12	
OIL APPEARANCE	6	DISASSEMBLY	12	
OIL LEAKAGE	6	INSPECTION AFTER DISASSEMBLY	12	
OIL PRESSURE CHECK	7	ASSEMBLY	13	
Changing Engine Oil	8	SERVICE DATA AND SPECIFICATIONS (SDS)	14	
OIL FILTER	9	Standard and Limit	14	
Removal and Installation	9	OIL PRESSURE	14	
REMOVAL	9	OIL PUMP	14	
INSTALLATION	9	REGULATOR VALVE	14	
INSPECTION AFTER INSTALLATION	9	OIL CAPACITY (APPROXIMATE)	14	
		Tightening Torque	14	

ENGINE MAINTENANCE

4. Drain engine coolant from both sides of cylinder block at B and C in the figure and cylinder block front at A in the figure when draining all the engine coolant in the system.
5. Check drained engine coolant for contaminants such as rust, corrosion or discoloration. If contaminated, flush the engine cooling system. Refer to [MA-16. "FLUSHING COOLING SYSTEM"](#).

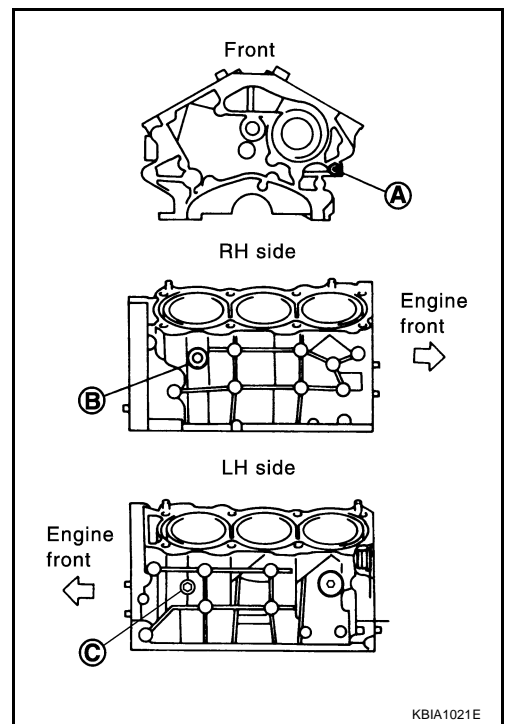

REFILLING ENGINE COOLANT

1. Install reservoir tank if removed, and radiator drain plug.
2. Close and tighten cylinder block drain plugs securely if removed.
 - **Apply sealant to the threads of the cylinder block drain plugs.**
 - **Use Genuine Thread Sealant or equivalent. Refer to [GI-47. "RECOMMENDED CHEMICAL PRODUCTS AND SEALANTS"](#).**

Radiator drain plug:

 : 0.78 - 1.6 N·m (0.08 - 0.15 kg·m, 7 - 13 in·lb)

Cylinder block drain plug (LH):

 : 17.6 - 21.6 N·m (1.8 - 2.2 kg·m, 13 - 15 ft·lb)

Cylinder block drain plug (RH):

 : 17.6 - 21.6 N·m (1.8 - 2.2 kg·m, 13 - 15 ft·lb)

Cylinder block drain plug (Front side):

 : 7.8 - 11.8 N·m (0.8 - 1.2 Kg·m, 69 - 104 in·lb)

3. Remove air relief plug on heater hose.

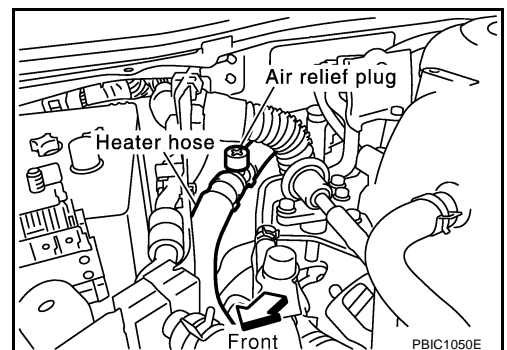

REAR OIL SEAL

REAR OIL SEAL

PFP:33140

Removal and Installation

ACS003TE

REMOVAL

1. Remove propeller shaft. Refer to [PR-7, "REMOVAL"](#) .

CAUTION:

Do not impact or damage propeller shaft tube.

2. Using oil seal puller, remove rear oil seal.

Tool number : KV381054S0 (—)

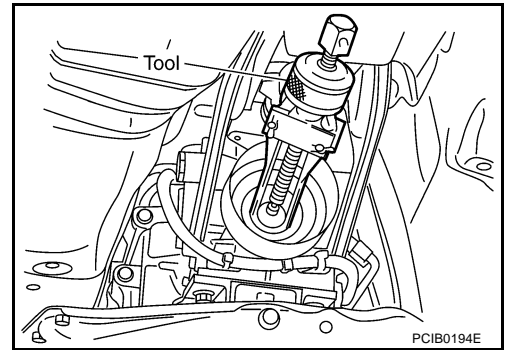

INSTALLATION

1. Apply multi-purpose grease to rear oil seal lip. Using a drift, drive in rear oil seal until the edge is approximately 1.2 - 2.2 mm (0.047 - 0.087 in) above the boss edge.

Tool number : ST33400001 (J26082)

CAUTION:

- Rear oil seals are not reusable. Never reuse them.
- When installing, do not incline the rear oil seal.

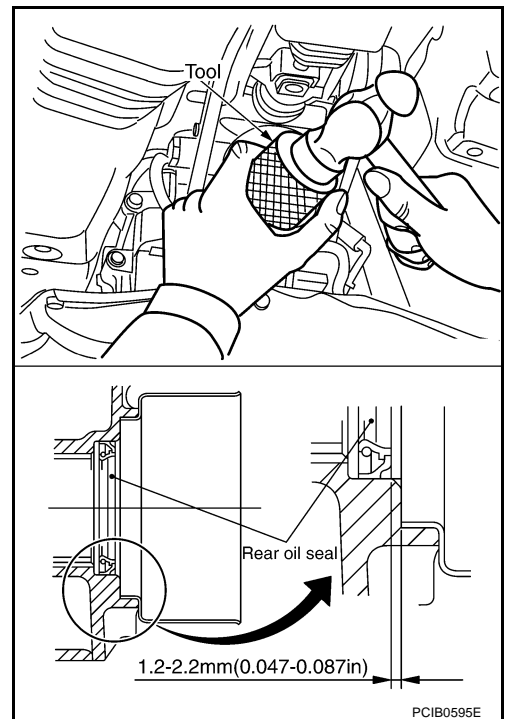

2. Install propeller shaft. Refer to [PR-8, "INSTALLATION"](#) .

CAUTION:

- Do not impact or damage propeller shaft tube.
- If lubricant leak has occurred, after finishing work, check oil level. Refer to [MT-10, "Checking"](#) .

TRANSMISSION ASSEMBLY

Follow the instructions below and inspect the clearance of the outer baulk ring, synchronizer cone, inner baulk ring.

CAUTION:

Clearances "A" and "B" of the outer baulk ring, synchronizer cone, and inner baulk ring are controlled as a set, so if the clearance is outside the limit value, replace the synchronizer assembly.

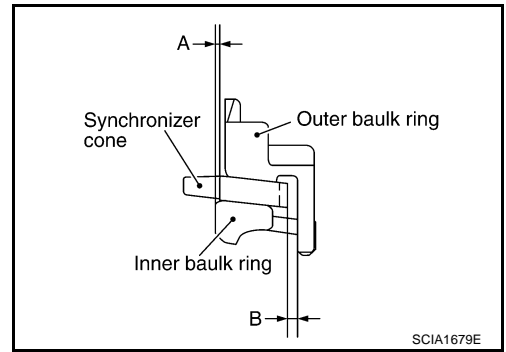

- Using a dial gauge, measure clearance A at 2 or more points diagonally opposite, and calculate mean value.

Clearance A

Standard : 0.5 - 0.7 mm (0.020 - 0.028 in)

Limit value : 0.3 mm (0.012 in) or less

Tool number : ST30031000 (J22912 - 01)

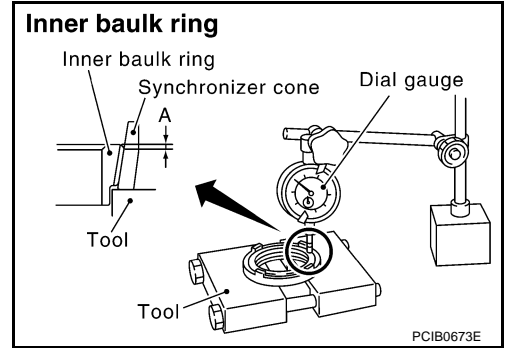

- Using a feeler gauge, measure clearance B at 2 or more points diagonally opposite, and calculate mean value.

Clearance B

Standard(1st) : 1.0 - 1.5mm(0.039 - 0.059 in)

Standard(3rd,4th) : 0.85 - 1.35mm (0.033 - 0.053 in)

Limit value : 0.7mm(0.028 in) or less

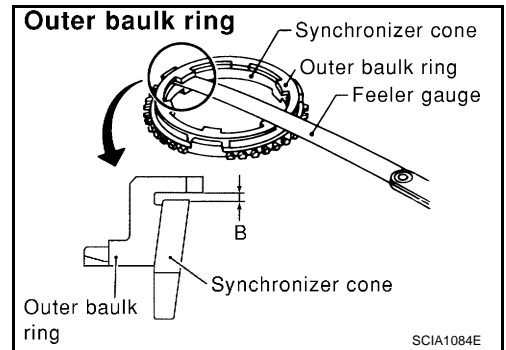

- Triple cone synchronizer (2nd)
Check clearance for 2nd outer baulk ring, 2nd synchronizer cone, and 2nd inner baulk ring of triple cone synchronizer following the direction.

NOTE:

2nd outer baulk ring, 2nd synchronizer cone, and 2nd inner baulk ring, three control "clearance A, B and C" as a three-piece suite. If the value exceeds the limit value, replace them as a three-piece suite.

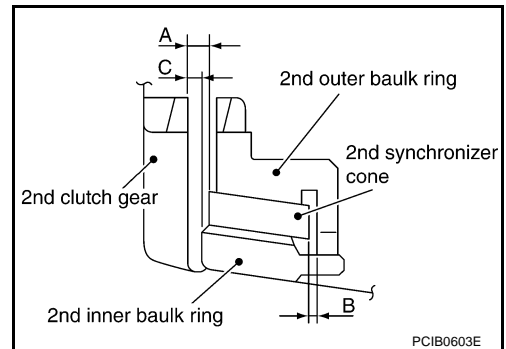

- Using feeler gauge put and press baulk ring on 2nd main gear taper cone, and then measure "clearance A" at more than 2 diagonal points, and calculate the average.

Clearance A

Reference value : 0.6-1.3 mm (0.024 - 0.051in)

Limit value : 0.3mm (0.012 in) or less

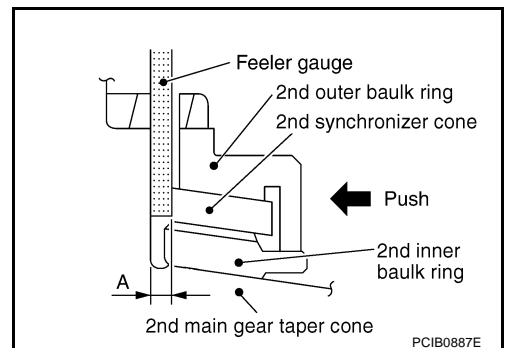

A
B
MT
D
E
F
G
H
I
J
K
L
M

PARKING BRAKE SHOE

INSPECTION AFTER REMOVAL

Lining Thickness Inspection

- Check the thickness of the lining.

Standard

Standard thickness (A) : 3.2 mm (0.126 in)

Repair limit thickness (A) : 1.5 mm (0.059 in)

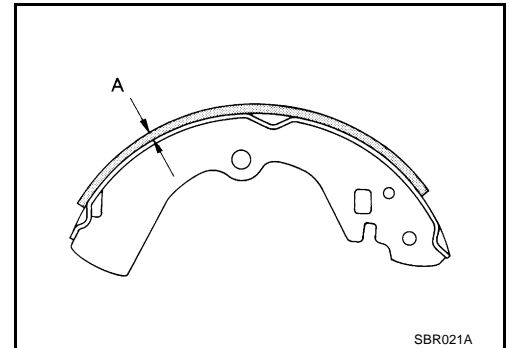

Drum Inner Diameter Inspection

- Check the inner diameter of the drum.

Standard

Standard inner diameter : 172 mm (6.77 in) dia.

Maximum inner diameter : 173 mm (6.81 in) dia.

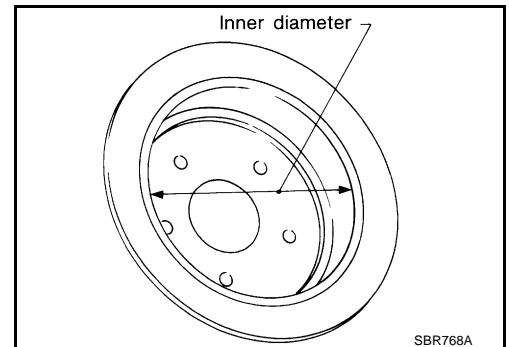

Other Inspections

- Check shoe sliding surface for excessive wear and damage.
- Check anchor pin for excessive wear and corrosion.
- Check return spring for sagging.
- Does adjuster move smoothly?
- Check either visually or with a vernier caliper to see if there is any excessive wear, cracks, or damage inside drum.

INSTALLATION

Be careful of the following:

- Refer to "Component Parts Location" and apply brake grease to the specified points during assembly.
- Orientation of the adjuster is different from left to right. Assemble adjuster so that threaded part expands when rotating it in the direction shown by the arrow.
- Collapse adjuster to assemble
- When disassembling adjuster, apply PBC (Poly Butyl Cuprysil) grease or silicone based grease to the threads.
- After replacing brake shoes or disc rotors, or if brakes do not function well, perform break-in operation as follows.

1. Adjust the parking brake lever stroke to the specified stroke.
2. Perform parking brake break-in (drag run) operation by driving the vehicle under the following conditions:

Drive forward

- **Vehicle speed approx. 35 km/h (22 MPH) set (forward)**
- **Parking brake operating force approx. 147 N (15 kg, 33 lb) set**
- **Distance approx. 100 m (328 ft)**
- **Repeat three times. [Total 300 m (984 ft)]**

3. After break-in operation, check lever stroke of the parking brake. Readjust if it is no longer at the specified stroke.
 - To prevent lining from getting too hot, allow a cool off period of approximately 5 minutes after every break-in operation.
 - Do not perform excessive break-in operations, because it may cause uneven or early wear of the lining.

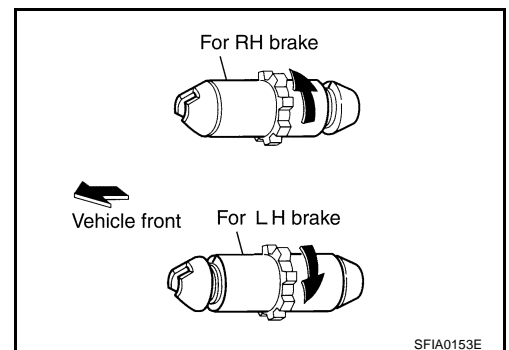

GROUND

A
B
C
D
E
F
G
H
I
J
PG
L
M

A Preceding page

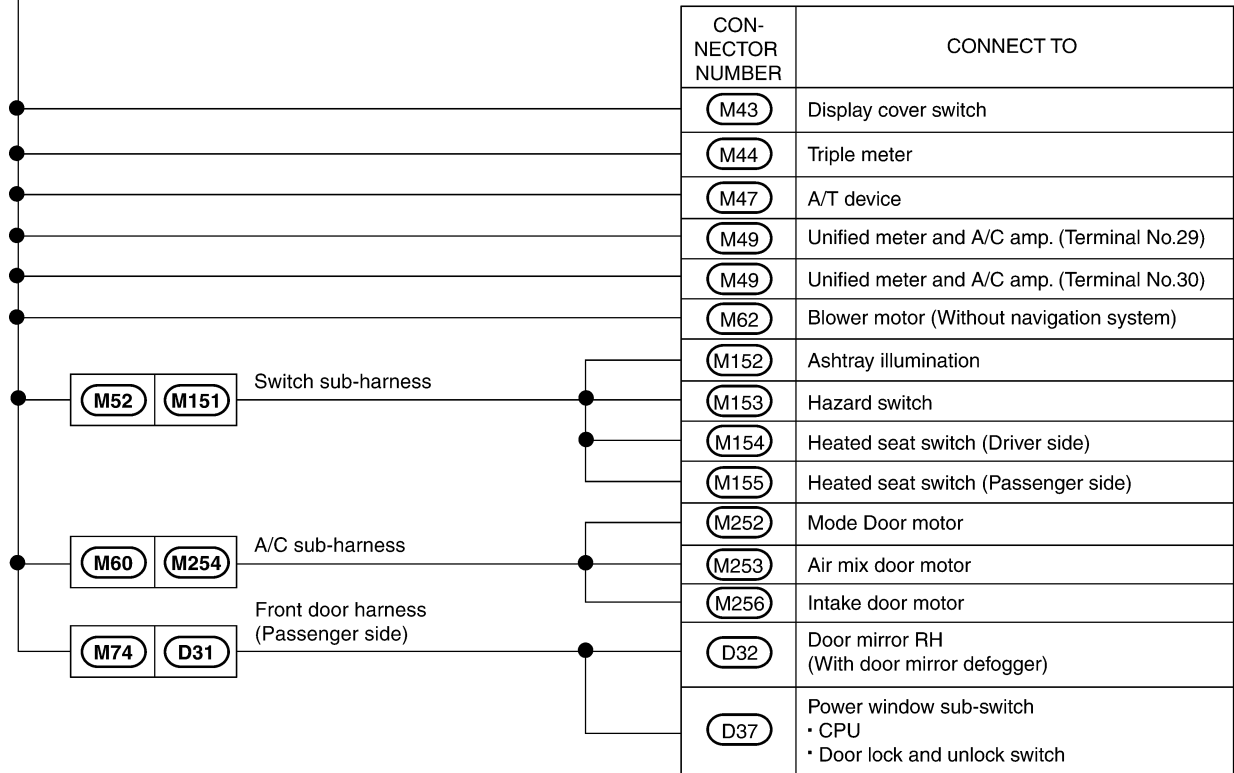
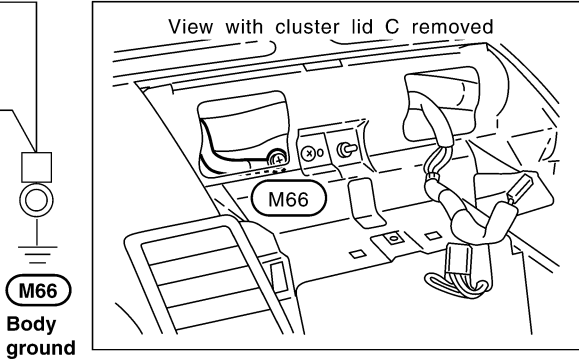

HARNESS

ROOM LAMP HARNESS

Room lamp sub-harness

(R51) W/4 : To (M70)
(R63) W/4 : Map lamp

(R1) W/10 : To (M69)
(R3) W/2 : Vanity mirror lamp (Driver side)
(R4) B/10 : Auto anti-dazzling inside mirror
(R5) W/2 : Vanity mirror lamp (Passenger side)

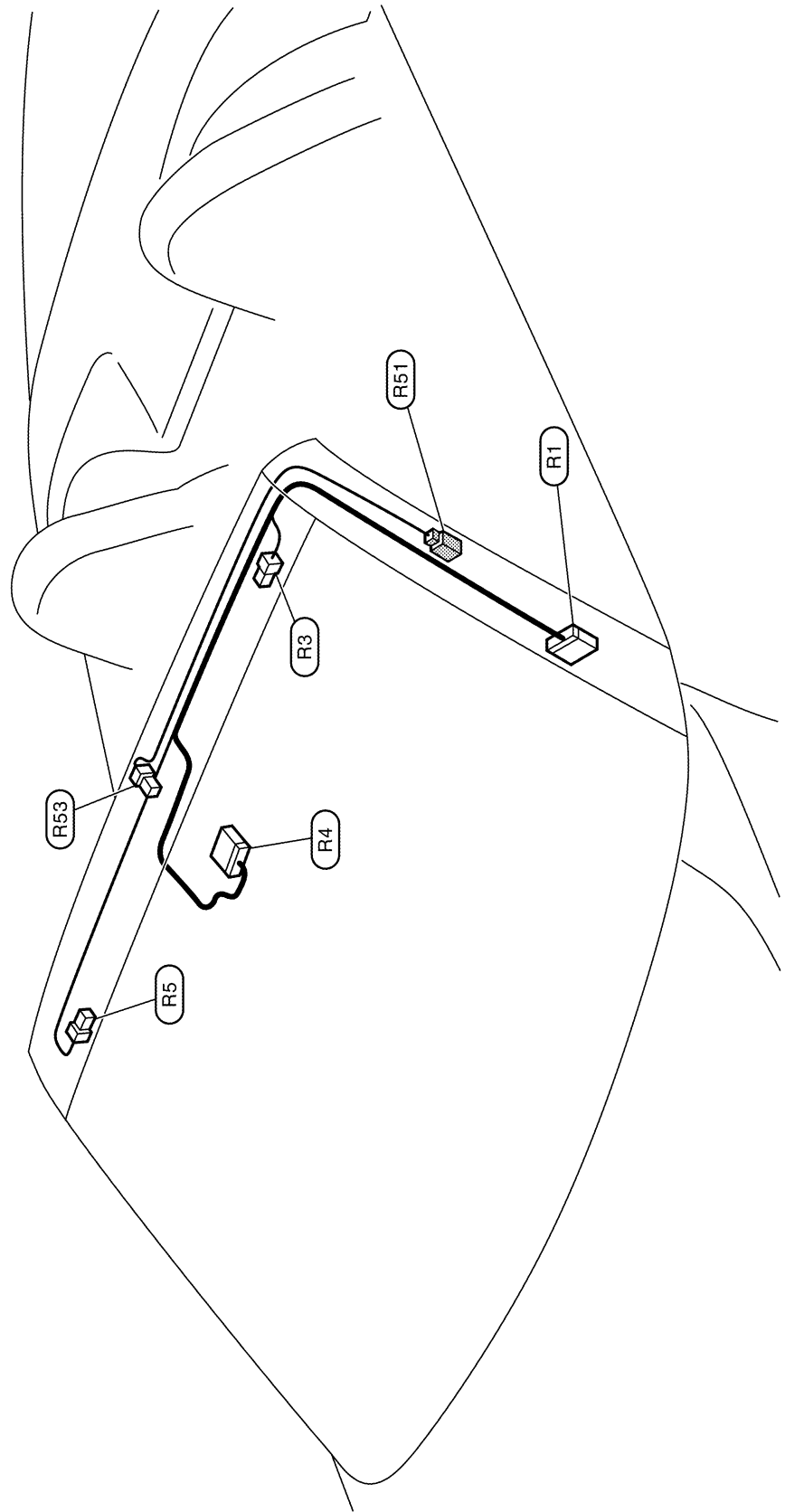

A
B
C
D
E
F
G
H
I
J
PG
L
M

REAR PROPELLER SHAFT

Companion Flange Installation

ADS00080

If companion flange has been removed, put new alignment marks B and C on it. Then, reassemble using the following procedure. (Perform step 4 when final drive and propeller shaft are separated from each other. Also perform step 4 when either of these parts is replaced with a new one.)

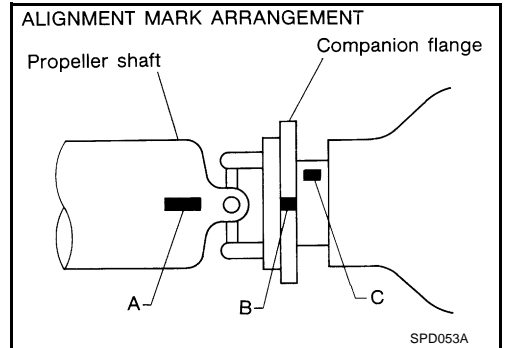

1. Erase original marks B and C from companion flange with suitable solvent.
2. Measure companion flange vertical runout.
3. Determine the position where maximum runout is read on dial gauge. Put mark (shown by B in figure) on flange perimeter corresponding to maximum runout position.

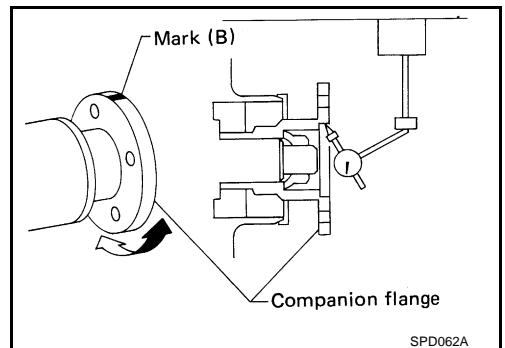

4. Measure companion flange surface runout.
5. Determine the position where maximum runout is read on dial gauge. Put mark (shown by C in figure) on flange perimeter corresponding to maximum runout position.

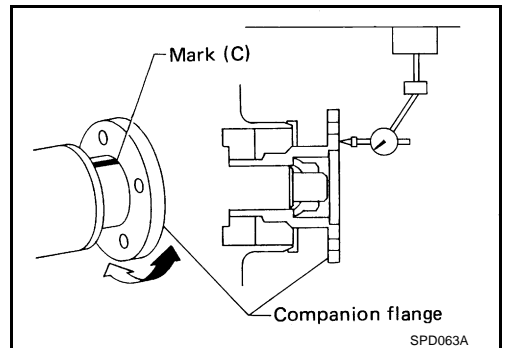

6. Position companion flange and propeller shaft using alignment marks A and B. Set the marks A and B as close to each other as possible. Temporarily attach bolts and nuts.
7. Press down propeller shaft with alignment mark C facing upward. Then tighten the lower nut to specified torque.
8. Tighten remaining nuts to specified torque.

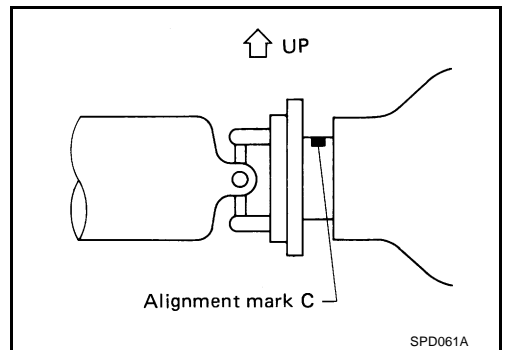

POWER STEERING GEAR

18. Set dial gauge to rack as shown in the figure. Measure vertical movement of rack when pinion is turned counterclockwise with torque of 19.6 N·m (2.0 kg·m, 14 ft·lb). Check reading is within the specified value. If reading is outside of the specification, readjust screw angle with adjusting screw. If reading is still outside of specification, or if the rotating torque of adjusting screw is less than 5 N·m (0.51 kg·m, 44 in·lb), replace steering gear assembly.

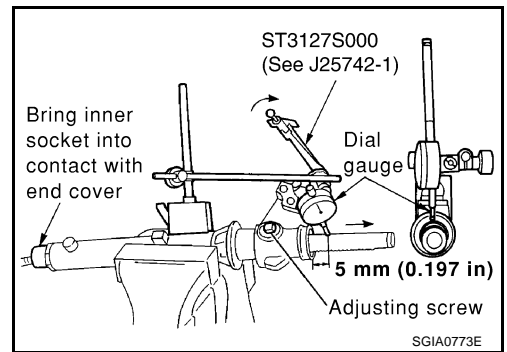

Specified value

Amount of vertical movement with rack	Less than 0.265 mm (0.010 in)	
Measuring point	Axial direction of rack	5 mm (0.197 in) away from end of gear housing
	Radius direction of rack	Shaft direction of adjusting screw

19. Install large-diameter side of boot to gear housing assembly.
 20. Install small-diameter side of boot to the mounting groove of inner socket boot.
 21. Install boot clamp to the small-diameter side of boot.
 22. Install boot clamp to the large-diameter side of boot.

NOTE:

Do not reuse boot clamp.

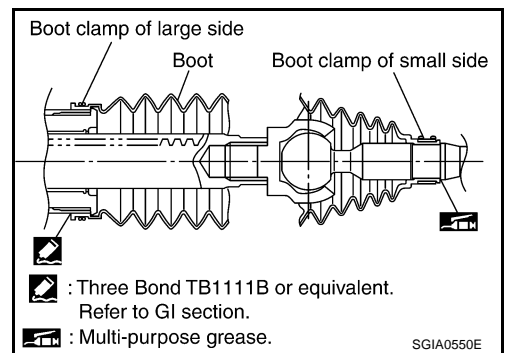

- a. Tighten large-diameter side of RH/LH boot with boot clamp (stainless wire).

Wire length "L" : 370 mm (14.567 in)

- b. After wrapping clamp around boot groove for two turns, insert screwdriver in loop on both ends of wire. Twist 4 to 4.5 turns while pulling with a force of approx. 98 N (10 kg, 22.1 lb).

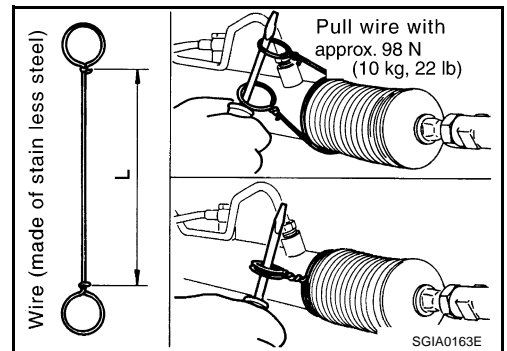

- c. Twist boot clamp as shown in the figure, pay attention to relationship between winding and twisting directions.

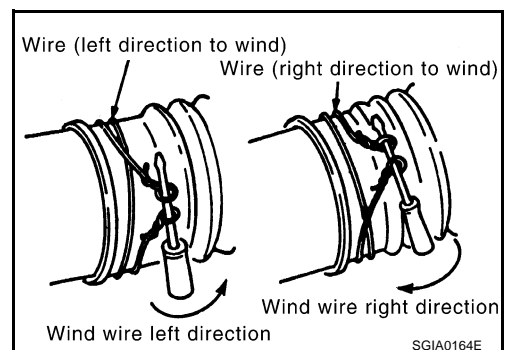

SERVICE DATA

SERVICE DATA

PFP:00030

Wheel Bearing

ADS0003G

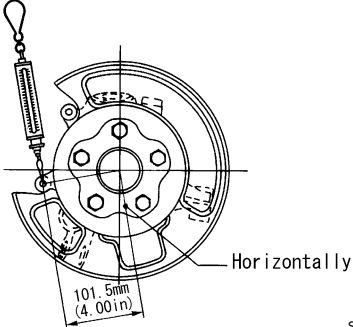
Axial end play	0.05 mm (0.002 in) or less
Rotating torque	At a load of 49,033 N (5,000 kg, 11,000 lb) Less than 1.88 N·m (0.19 kg-m, 17 in-lb)
Measurement of spring scale	Less than 18.5 N (1.89 kg, 4.16 lb)
Measuring point (Brake caliper installation points)	 <p>Horizontally</p> <p>101.5mm (4.001in)</p> <p>SDIA0801E</p>

A

B

C

RAX

E

F

Drive Shaft

ADS0003H

Joint type	Wheel side	Final drive side
Grease quantity	86 - 96 g (3.03 - 3.39 oz)	124 - 134 g (4.37 - 4.73 oz)
Boots installed length	97 mm (3.82 in)	93.9 mm (3.697 in)

G

H

Tightening Torque

ADS00082

Drive shaft - Side flange	63 - 79 N·m (6.5 - 8.0 kg-m, 47 - 58 lb)
Hub lock nut	206 - 274 N·m (21 - 27 kg-m, 152 - 202 lb)

I

J

K

L

M

A
B
C
D
E
F
G
H
RF
J
K
L
M

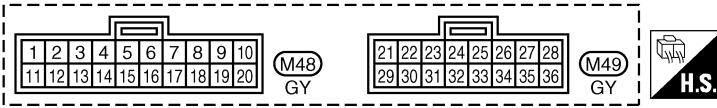
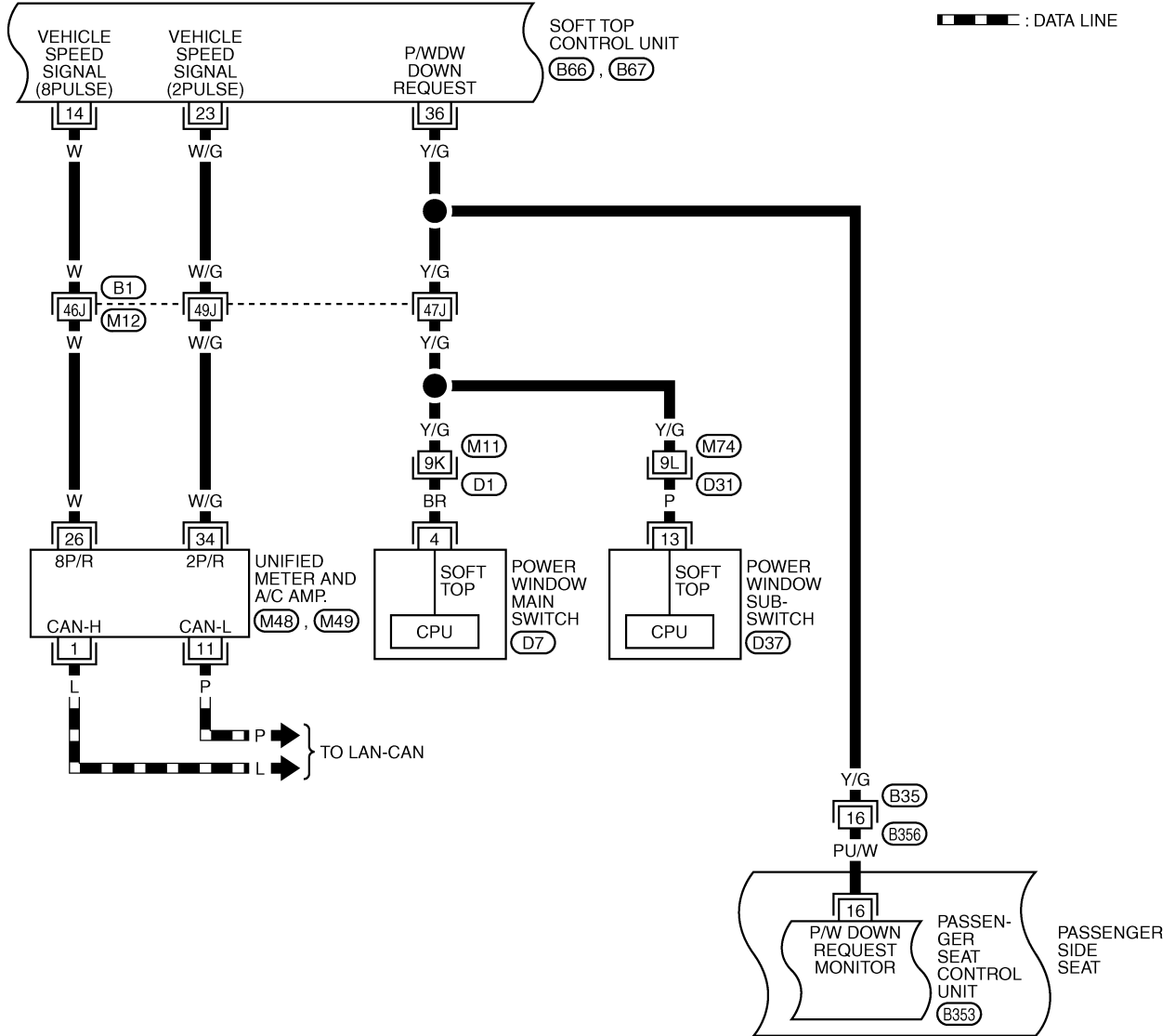

REFER TO THE FOLLOWING.
(B1), (D1), (D31) -SUPER
MULTIPLE JUNCTION (SMJ)

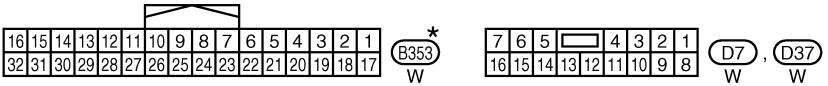
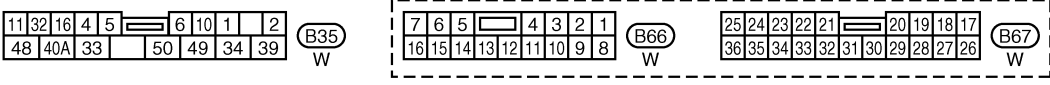

*: THIS CONNECTOR IS NOT SHOWN IN "HARNESS LAYOUT", PG SECTION.

SOFT TOP

Roll Bar Interference Prevention Switch Check (Open Operate)

AI50064F

1. CHECK ROLL BAR INTERFERENCE PREVENTION SWITCH SIGNAL

1. Start engine.
2. Operate soft top switch OPEN, check voltage between soft top control unit connector and ground.

Connector	Terminal (Wire color)		Roof condition	Voltage (V) (Approx.)
	(+)	(-)		
B67	22 (W/R)	Ground	OP8 → OP9	5 → 0

OK or NG

- OK >> Roll bar interference prevention switch is OK.
 NG >> GO TO 2.

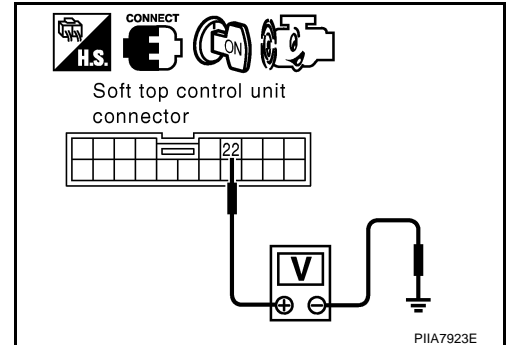

2. CHECK ROLL BAR INTERFERENCE PREVENTION SWITCH CIRCUIT

1. Turn ignition switch OFF.
2. Disconnect soft top control unit and soft top switch assembly 2 (roll bar interference prevention switch) connector.
3. Check continuity between soft top control unit connector B67 terminal 22 and soft top switch assembly 2 connector B213 terminal 3.

22 (W/R) - 3 (W/R) : Continuity should exist.

4. Check continuity between soft top control unit connector B67 terminal 22 and ground.

22 (W/R) - Ground : Continuity should not exist.

OK or NG

- OK >> GO TO 3.
 NG >> Repair or replace harness.

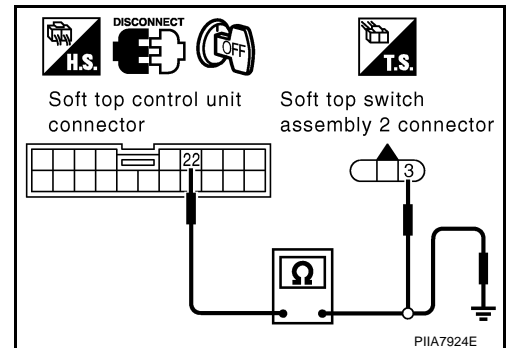

3. CHECK ROLL BAR INTERFERENCE PREVENTION SWITCH GROUND CIRCUIT

Check continuity between soft top switch assembly 2 connector B213 terminal 1 and ground.

1 (B) - Ground : Continuity should exist.

OK or NG

- OK >> GO TO 4.
 NG >> Repair or replace harness.

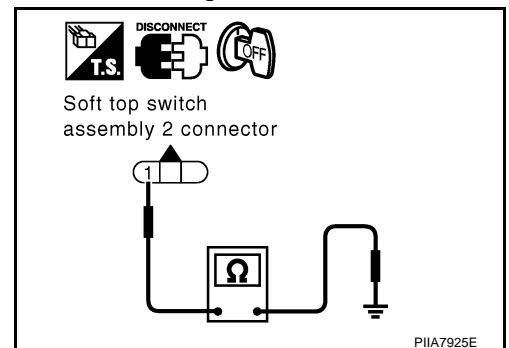

SOFT TOP

2. CHECK SEAT BACK POSITION SIGNAL CIRCUIT

1. Turn ignition switch OFF.
2. Disconnect soft top control unit and passenger side seat control unit connector.
3. Check continuity between soft top control unit connector B67 terminal 34 and passenger side seat control unit connector B353 terminal 32.

34 (L/W) - 32 (G/W) : Continuity should exist.

4. Check continuity between soft top control unit connector B67 terminal 34 and ground.

34 (L/W) - Ground : Continuity should not exist.

OK or NG

OK >> Check passenger side seat. Refer to [SE-32, "Trouble Diagnosis Symptom Chart"](#).

NG >> Repair or replace harness.

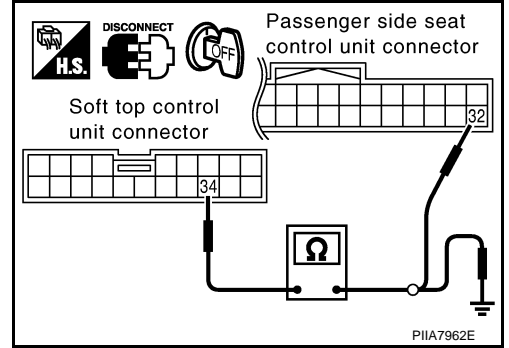

Speed Signal Circuit Check

AIS00655

First perform the "SELF-DIAG RESULT" in "BCM" with CONSULT-II, then perform the each trouble diagnosis of malfunction system indicated "SELF-DIAG RESULT" of "BCM". Refer to [BCS-11, "CONSULT-II"](#).

1. CHECK VEHICLE SPEED SIGNAL

1. Start engine.
2. Check the signal between soft top control unit connector and ground.

Connector	Terminal (Wire color)		Condition	Signal (Reference value.)
	(+)	(-)		
B66	14 (W)	Ground	Speedometer operated [When vehicle speed is Approx. 40km/h (25MPH)]	
B67	23 (W/G)			

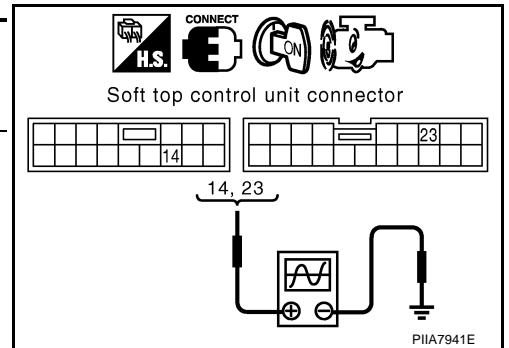

OK or NG

OK >> Replace soft top control unit.

NG >> GO TO 2.

SOFT TOP

3. For fixing harness to 5th bow and Soft top frame, see next figure.

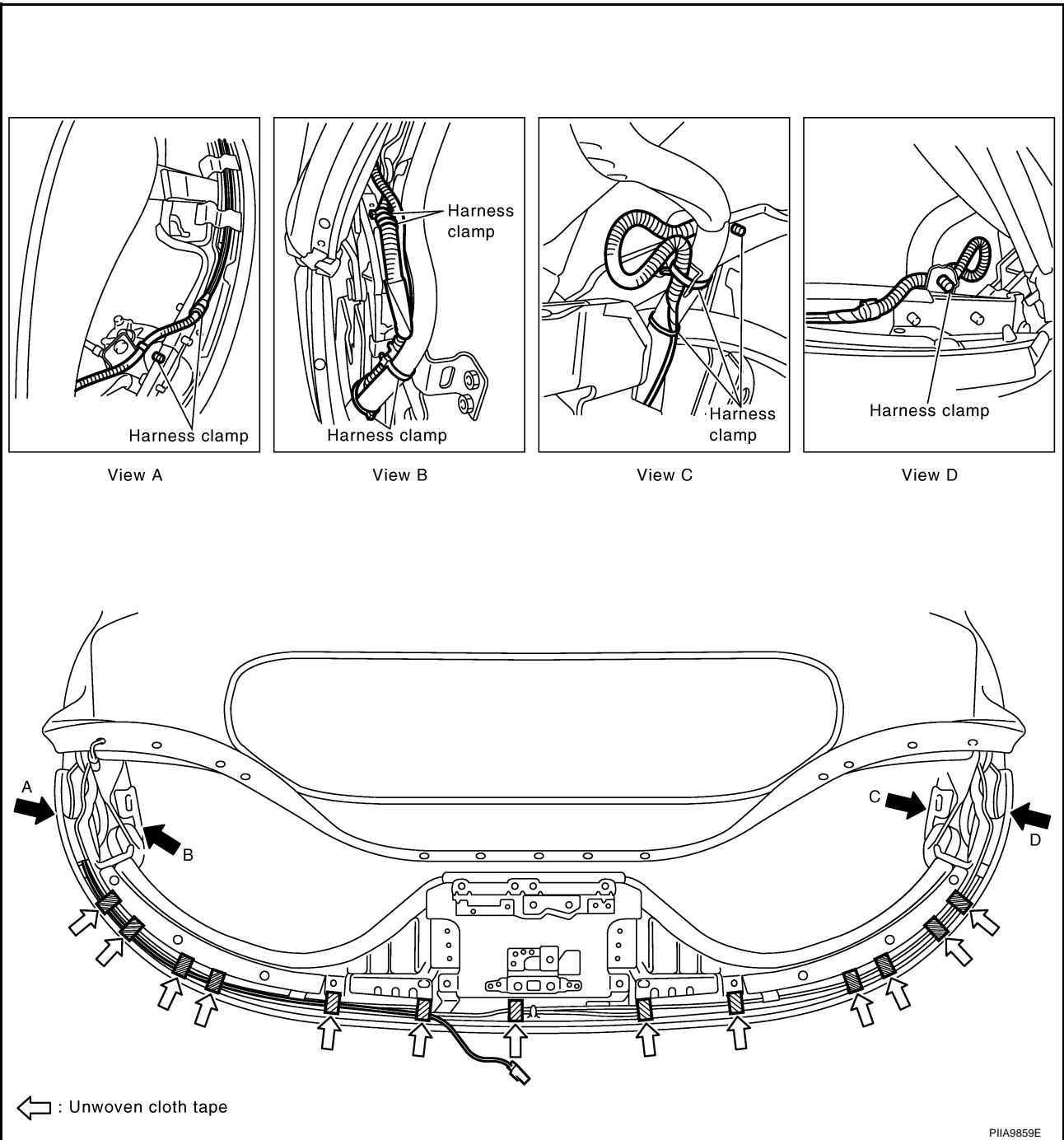

A
B
C
D
E
F
G
H
RF
J
K
L
M

SIDE OIL SEAL

3. Install the side flange with the following procedure.

a. Attach the protector to side oil seal.

Tool number : KV38107900 (J39352)

b. After the side flange is inserted and the serrated part of side gear has engaged the serrated part of flange, remove the protector.

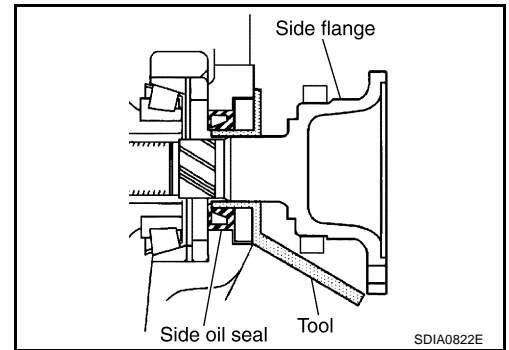

c. Put suitable drift on the center of side flange, then drive it until sound changes.

NOTE:

When installation is completed, driving sound of the side flange turns into a sound which seems to affect the whole final drive.

4. Confirm that the dimension of the side flange installation (Measurement A) in the illustration comes into the following, then install the drive shaft.

Measurement A

: Approx. 326 - 328 mm (12.83 - 12.91 in)

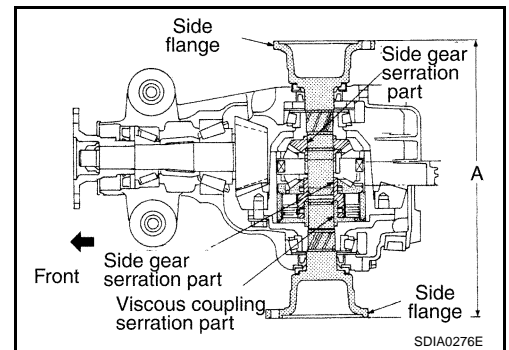

5. Align the installing position of the ABS wheel sensor. Refer to [BRC-42, "WHEEL SENSORS"](#).

SECTION **RSU**
REAR SUSPENSION

A
B
C
D

RSU

CONTENTS

PRECAUTIONS	2	SUSPENSION ARM	11	F
Cautions	2	Removal and Installation	11	
PREPARATION	3	REMOVAL	11	G
Special Service Tools (SST)	3	INSPECTION AFTER REMOVAL	11	
Commercial Service Tools	3	INSTALLATION	12	
NOISE, VIBRATION AND HARSHNESS (NVH)		RADIUS ROD	13	H
TROUBLESHOOTING	4	Removal and Installation	13	
NVH Troubleshooting Chart	4	REMOVAL	13	
REAR SUSPENSION ASSEMBLY	5	INSPECTION AFTER REMOVAL	13	I
On-Vehicle Inspection and Service	5	INSTALLATION	13	
INSPECTION OF SUSPENSION ARM BALL		FRONT LOWER LINK	14	J
JOINT END PLAY	5	Removal and Installation	14	
SHOCK ABSORBER INSPECTION	5	REMOVAL	14	
Wheel Alignment Inspection	5	INSPECTION AFTER REMOVAL	14	
DESCRIPTION	5	INSTALLATION	14	
PRELIMINARY INSPECTION	5	REAR LOWER LINK & COIL SPRING	15	K
CAMBER INSPECTION	5	Removal and Installation	15	
TOE-IN	6	REMOVAL	15	
Components	7	INSPECTION AFTER REMOVAL	15	
Removal and Installation	8	INSTALLATION	15	L
REMOVAL	8	STABILIZER BAR	16	
INSTALLATION	8	Removal and Installation	16	
SHOCK ABSORBER	9	REMOVAL	16	
Removal and Installation	9	INSPECTION AFTER REMOVAL	16	M
REMOVAL	9	INSTALLATION	16	
INSPECTION AFTER REMOVAL	9	REAR SUSPENSION MEMBER	17	
INSTALLATION	9	Removal and Installation	17	
Disassembly and Assembly	9	REMOVAL	17	
DISASSEMBLY	9	INSPECTION AFTER REMOVAL	17	
INSPECTION AFTER DISASSEMBLY	10	INSTALLATION	17	
ASSEMBLY	10	SERVICE DATA	18	
		Wheel Alignment	18	
		Ball Joint	18	
		Wheelarch Height (Unladen*)	18	

PREPARATION

PREPARATION

PFP:00002

Special Service Tool

AKS0098M

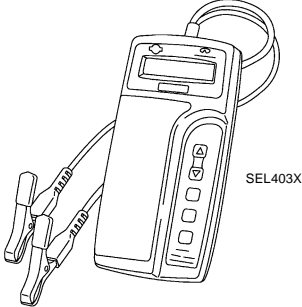
Tool number Tool name	Description
J-44373 Model 620 Battery/Starting/Charging system tester	

Commercial Service Tools

AKS0098N

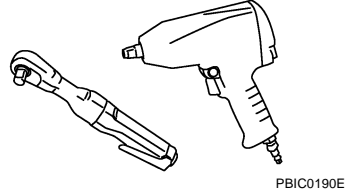
Tool number Tool name	Description
Power tool	

A
B
C
D
E
F
G
H
I
J
SC
L
M

SC

CHARGING SYSTEM

Removal and Installation

AKS00990

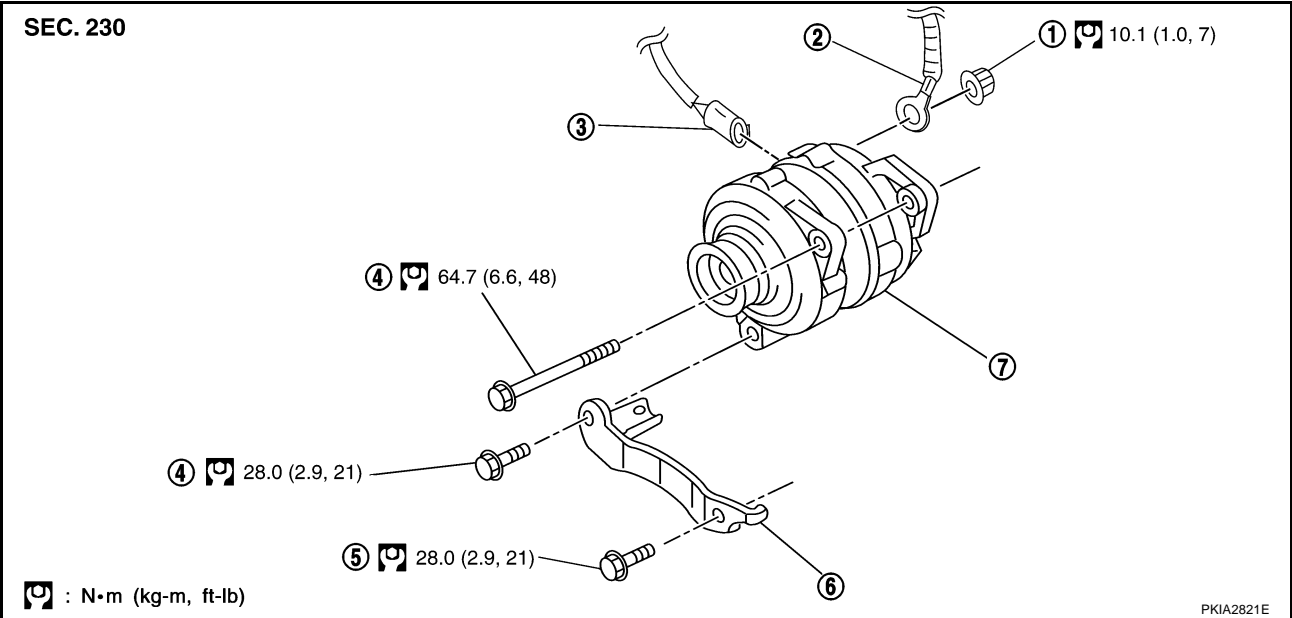

- | | | |
|-----------------------------|----------------------------------|-------------------------|
| 1. B terminal nut | 2. Alternator B terminal harness | 3. Alternator connector |
| 4. Alternator mounting bolt | 5. Alternator stay mounting bolt | 6. Alternator stay |
| 7. Alternator | | |

REMOVAL

1. Open the driver and front passenger window, and then disconnect the battery negative cable.

CAUTION:

Before disconnecting the battery, lower both the driver and passenger windows. This will prevent any interference between the window edge and the vehicle when the door is opened/closed. During normal operation, the window slightly raises and lowers automatically to prevent any window to vehicle interference. The automatic window function will not work with the battery disconnected.

2. Remove engine undercover, using power tools.
3. Remove radiator fan assembly. Refer to [CO-11, "RADIATOR"](#) in "ENGINE COOLING SYSTEM (CO)" section.
4. Remove alternator and power steering belt. Refer to [EM-14, "Removal and Installation"](#) in "ENGINE MECHANICAL (EM)" section.
5. Remove oil pressure harness clip from alternator stay.
6. Disconnect oil pressure switch connector.
7. Remove alternator stay mounting bolts and alternator stay, using power tools.
8. Remove alternator mounting bolt, using power tools.

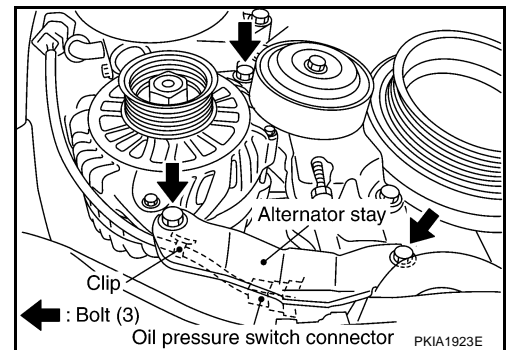

POWER SEAT

SE-SEAT-02

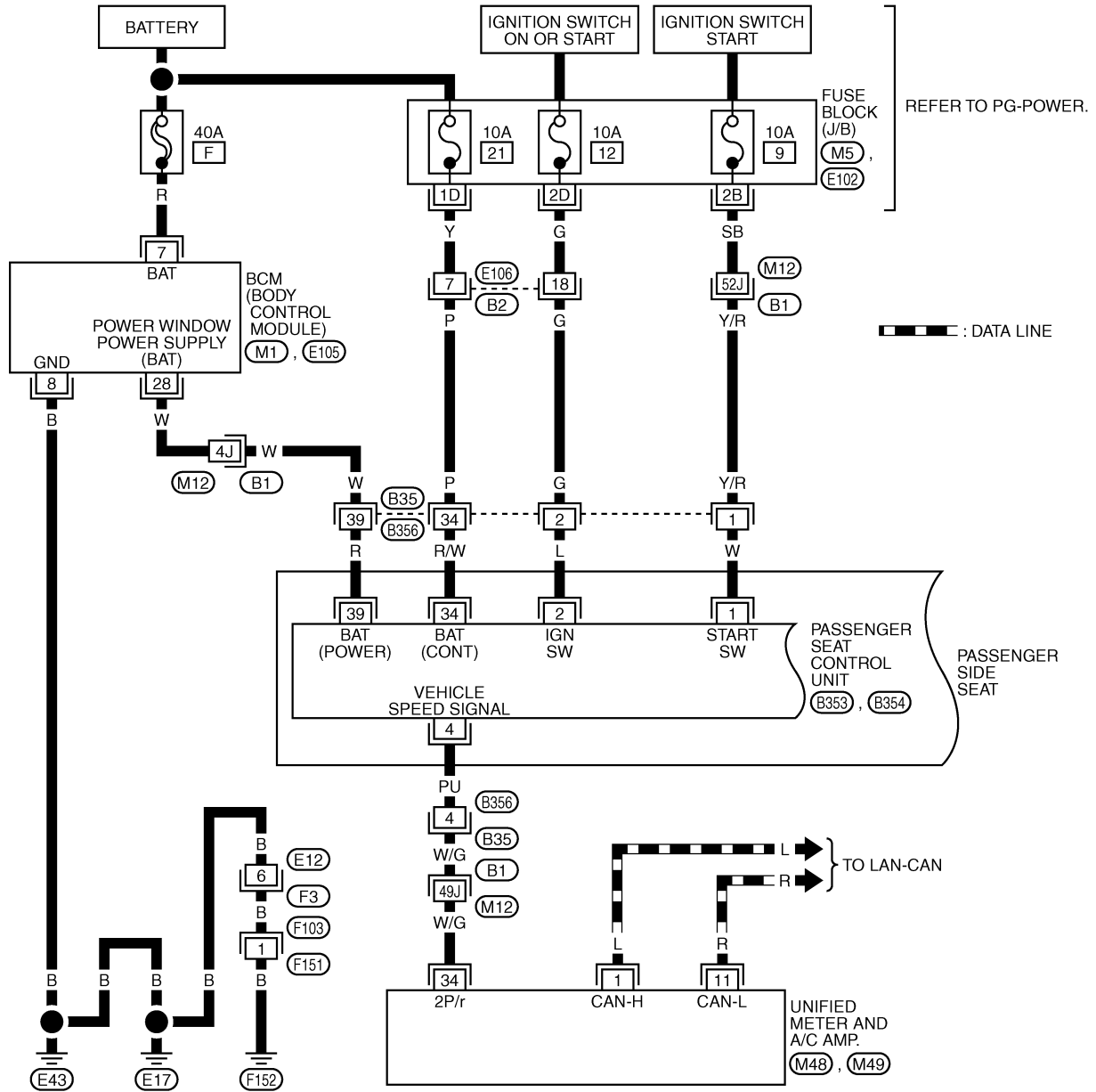

A
B
C
D
E
F
G
H
SE
J
K
L
M

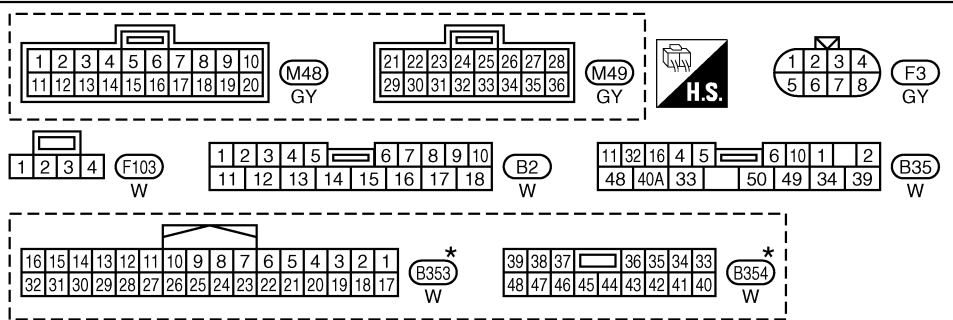

REFER TO THE FOLLOWING.
 (B1) -SUPER MULTIPLE JUNCTION (SMJ)
 (M5), (E102) -FUSE BLOCK-JUNCTION BOX (J/B)
 (M1), (E105) -ELECTRICAL UNITS

* : THIS CONNECTOR IS NOT SHOWN IN "HARNESS LAYOUT", PG SECTION.

TIWT0512E

POWER SEAT

3. CHECK SEAT BELT BUCKLE SWITCH

Check continuity between seat belt buckle switch as follows.

Terminals		Condition	Continuity
1	2	When seat belt is unfastened.	Yes
		When seat belt is fastened.	No

OK or NG

- OK >> GO TO 4.
- NG >> Replace seat belt buckle switch.

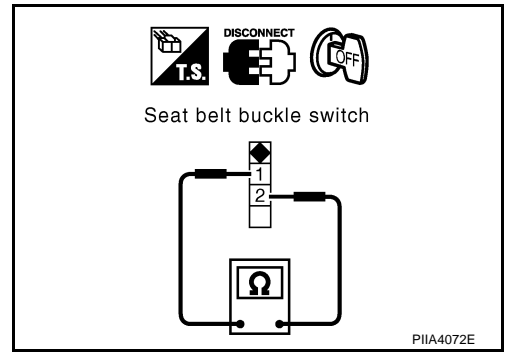

4. CHECK SEAT BELT BUCKLE SWITCH GROUND CIRCUIT

Check continuity between seat belt buckle switch connector B11 terminal 2 (B) and ground.

2 (B) - Ground : Continuity should exist.

OK or NG

- OK >> Check the condition of the harness and connector.
- NG >> Repair or replace the harness between seat belt buckle switch and ground.

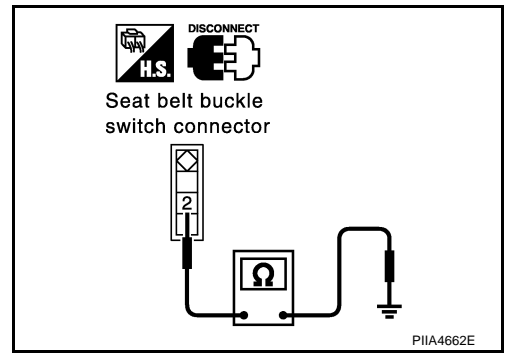

Vehicle Speed Signal Inspection

1. CHECK VEHICLE SPEED SIGNAL

1. Turn ignition switch ON.
2. Check signal between passenger seat control unit connector and body ground, with oscilloscope when vehicle speed is approx. 40 km/h (25 MPH).

Connector	Terminal (Wire color)		Condition	Voltage (V) (Approx.)
	(+)	(-)		
B353	4 (PU)	Ground	Speedometer operated [When vehicle speed is approx. 40 km/h (25 MPH)].	

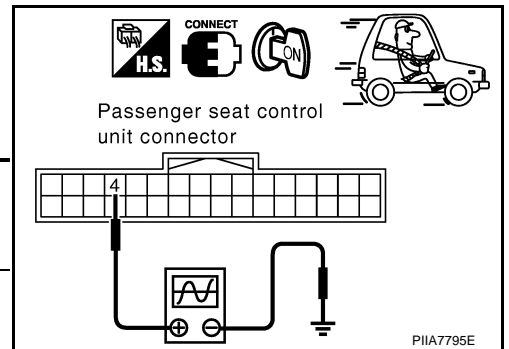

OK or NG

- OK >> Replace passenger seat control unit.
- NG >> GO TO 2.

CLICK HERE TO **DOWNLOAD** THE COMPLETE MANUAL

- Thank you very much for reading the preview of the manual.
- You can download the complete manual from: www.heydownloads.com by clicking the link below



- Please note: If there is no response to CLICKING the link, please download this PDF first and then click on it.

CLICK HERE TO **DOWNLOAD** THE COMPLETE MANUAL