

NISSAN PATHFINDER

MODEL R50 SERIES

QUICK REFERENCE INDEX

GENERAL INFORMATION _____	GI
MAINTENANCE _____	MA
ENGINE MECHANICAL _____	EM
ENGINE LUBRICATION & _____ COOLING SYSTEMS	LC
ENGINE CONTROL SYSTEM _____	EC
ACCELERATOR CONTROL, FUEL & _____ EXHAUST SYSTEMS	FE
CLUTCH _____	CL
MANUAL TRANSMISSION _____	MT
AUTOMATIC TRANSMISSION _____	AT
TRANSFER _____	TF
PROPELLER SHAFT & _____ DIFFERENTIAL CARRIER	PD
FRONT AXLE & FRONT SUSPENSION _____	FA
REAR AXLE & REAR SUSPENSION _____	RA
BRAKE SYSTEM _____	BR
STEERING SYSTEM _____	ST
RESTRAINT SYSTEM _____	RS
BODY & TRIM _____	BT
HEATER & AIR CONDITIONER _____	HA
ELECTRICAL SYSTEM _____	EL
ALPHABETICAL INDEX _____	IDX

CLICK HERE TO **DOWNLOAD** THE COMPLETE MANUAL

- Thank you very much for reading the preview of the manual.
- You can download the complete manual from: www.heydownloads.com by clicking the link below



- Please note: If there is no response to CLICKING the link, please download this PDF first and then click on it.

CLICK HERE TO **DOWNLOAD** THE COMPLETE MANUAL

OVERALL SYSTEM

Wiring Diagram — AT — (Cont'd)

AT-A/T-02

GI

MA

EM

LC

EC

FE

CL

MT

AT

TF

PD

FA

RA

BR

ST

RS

BT

HA

EL

IDX

— : Detectable line for DTC
 — : Non-detectable line for DTC

4W : 4WD model

Refer to EL-POWER.

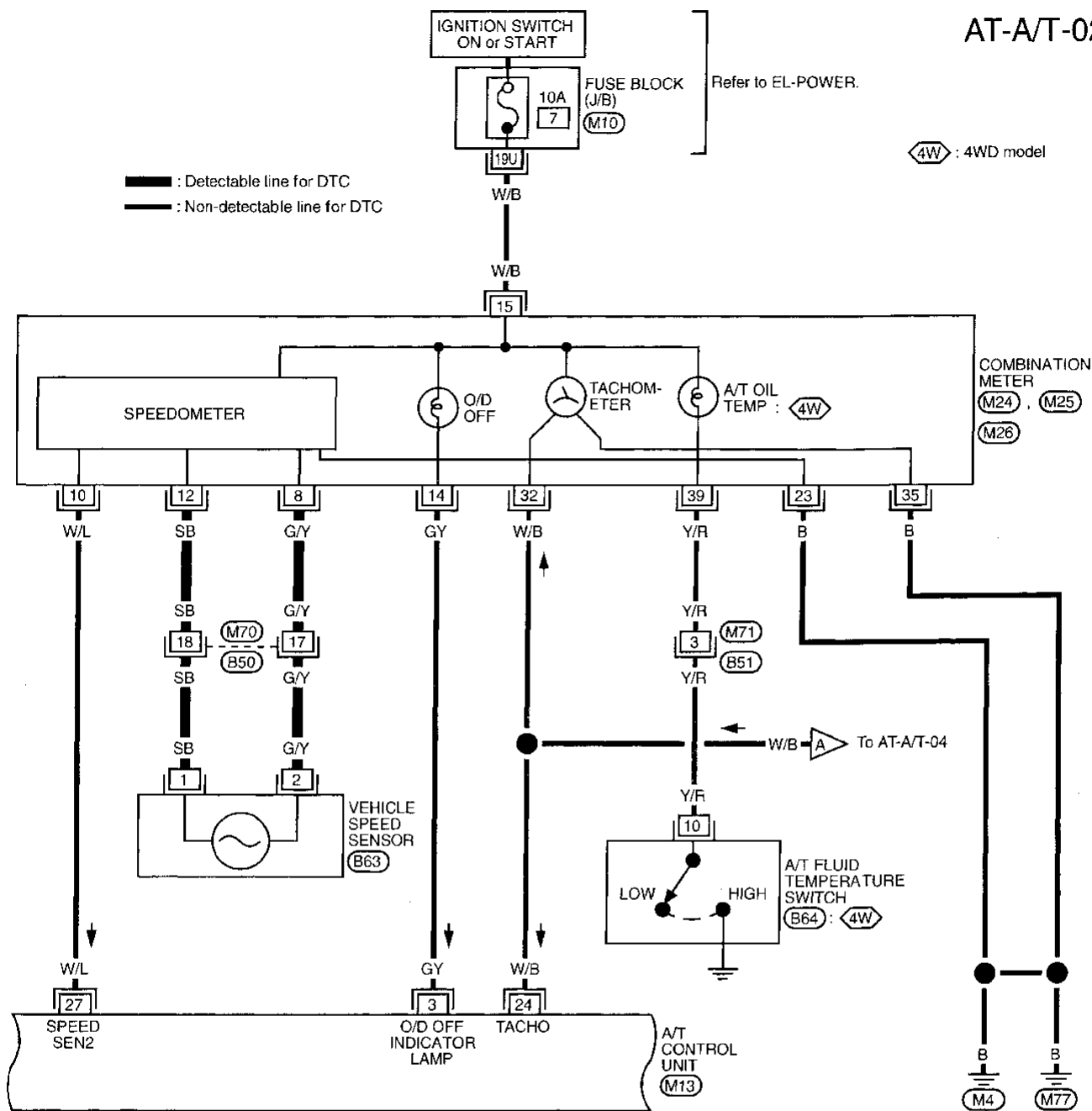

Refer to last page (Foldout page).

M10
 M13

RS

BT

HA

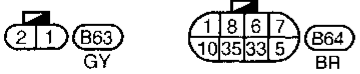
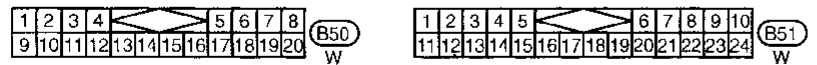
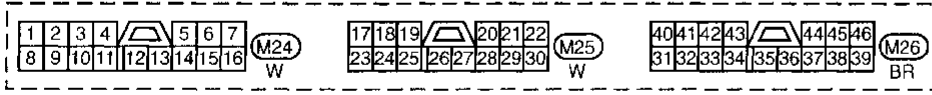

EL

IDX

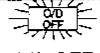

ON BOARD DIAGNOSTIC SYSTEM DESCRIPTION

Self-diagnosis (Cont'd)

Detected items (Screen terms for CONSULT, "SELF-DIAG RESULTS" test mode)	Malfunction is detected when ...	Indicator for Diagnostic Results	
		 O/D OFF indicator lamp (Available when "A/T" on CONSULT is touched.)	 Malfunction indicator lamp*2 (Available when "ENGINE" on CONSULT is touched.)
A/T fluid temperature sensor (A/T FLUID TEMP SENSOR)	<ul style="list-style-type: none"> A/T control unit receives an excessively low or high voltage from the sensor. 	X	X
Initial start INITIAL START	<ul style="list-style-type: none"> This is not a malfunction message (Whenever shutting off a power supply to the control unit, this message appears on the screen.) 	X	—
No failure (NO SELF DIAGNOSTIC FAILURE INDICATED FURTHER TESTING MAY BE REQUIRED**)	<ul style="list-style-type: none"> No failure has been detected. 	X	X

X : Applicable

— : Not applicable

*1 : These malfunctions can not be displayed by MIL  if another malfunction is assigned to the O/D OFF indicator lamp

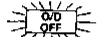

*2 : Refer to EC section ["Malfunction Indicator Lamp (MIL)", "ON BOARD DIAGNOSTIC SYSTEM DESCRIPTION"].

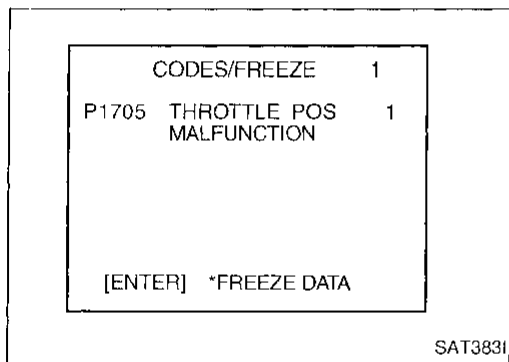

SELF-DIAGNOSTIC PROCEDURE (With GST)

Refer to EC section ["Generic Scan Tool (GST)", "ON BOARD DIAGNOSTIC SYSTEM DESCRIPTION"].

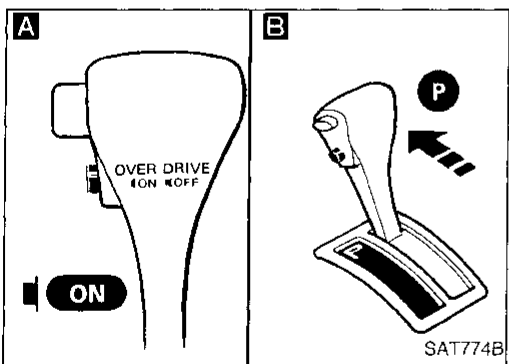

SELF-DIAGNOSTIC PROCEDURE (No Tools)

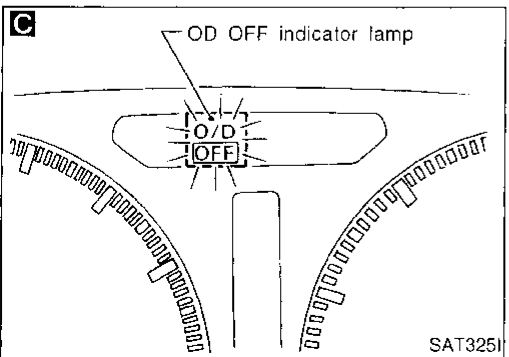
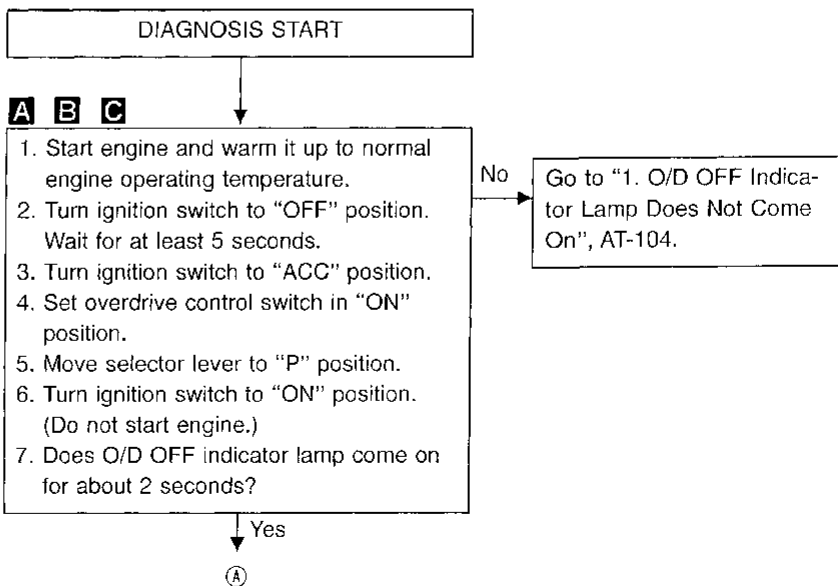

Road Test (Cont'd)

2. CHECK AT IDLE

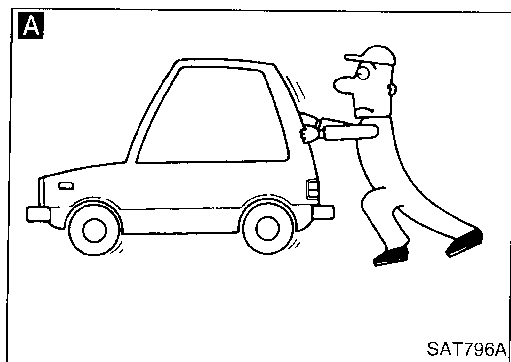

1. Park vehicle on flat surface.
2. Turn ignition switch to "OFF" position.
3. Move selector lever to "P" or "N" position.
4. Turn ignition switch to start position.
5. Is engine started?

No
Go to "2. Engine Cannot Be Started In "P" and "N" Position", AT-105.

Yes
1. Turn ignition switch to "OFF" position.
2. Move selector lever to "D", "1", "2" or "R" position.
3. Turn ignition switch to start position.
4. Is engine started?

Yes
Go to "2. Engine Cannot Be Started In "P" and "N" Position", AT-105.

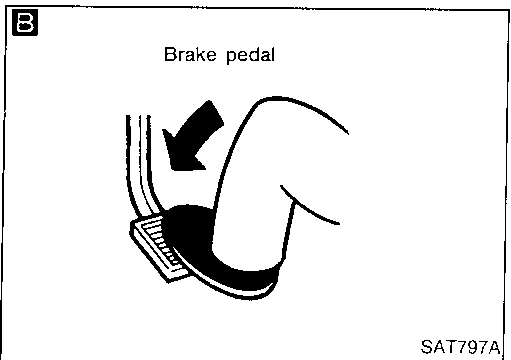

No
A
1. Turn ignition switch to "OFF" position.
2. Move selector lever to "P" position.
3. Release parking brake.
4. Push vehicle forward or backward.
5. Does vehicle move when it is pushed forward or backward?

Yes
Go to "3. In "P" Position, Vehicle Moves Forward Or Backward When Pushed", AT-105.

No
1. Apply parking brake.
2. Move selector lever to "N" position.
3. Turn ignition switch to "START" position and start engine.
4. Release parking brake.
5. Does vehicle move forward or backward?

Yes
Go to "4. In "N" Position, Vehicle Moves", AT-106.

No
B
1. Apply foot brake.
2. Move selector lever to "R" position.
3. Is there large shock when changing from "N" to "R" position?

Yes
Go to "5. Large Shock "N" → "R" Position", AT-107.

No
1. Release foot brake for several seconds.
2. Does vehicle creep backward when foot brake is released?

No
Go to "6. Vehicle Does Not Creep Backward In "R" Position", AT-108.

Yes
1. Move selector lever to "D", "1" and "2" position and check if vehicle creeps forward.
2. Does vehicle creep forward in all three positions?

No
Go to "7. Vehicle Does Not Creep Forward In "D", "2" Or "1" Position", AT-109.

Yes
Go to "3. Cruise test", AT-38.

CI
MA
EM
LC
EC
EE
CL
VT
AT
TF
PD
FA
RA
BR
ST
RS
BT
FA
EL
DX

TROUBLE DIAGNOSIS — General Description

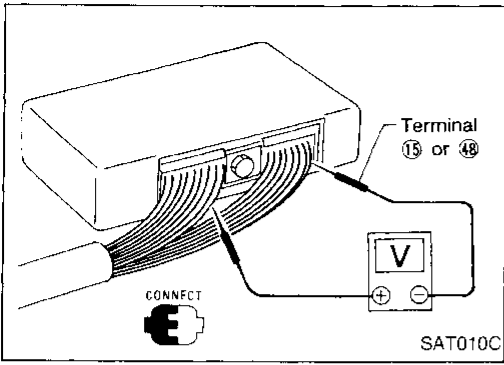

A/T Control Unit Terminals and Reference Value

PREPARATION

- Measure voltage between each terminal and terminal 15 or 48 by following "A/T CONTROL UNIT INSPECTION TABLE".

A/T CONTROL UNIT HARNESS CONNECTOR TERMINAL LAYOUT

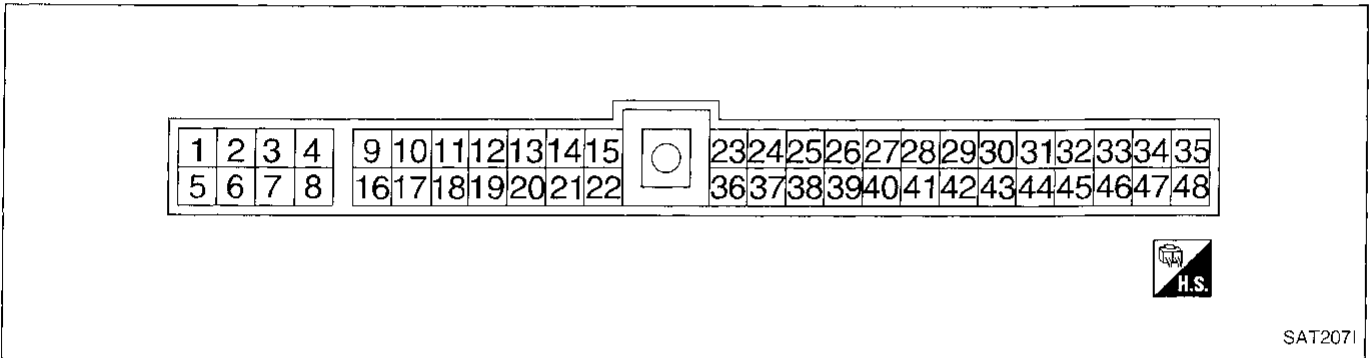

A/T CONTROL UNIT INSPECTION TABLE

(Data are reference values.)

Terminal No.	Item	Condition	Judgement standard
1	Line pressure solenoid valve	When releasing accelerator pedal after warming up engine.	1.5 - 2.5V
		When depressing accelerator pedal fully after warming up engine.	0.5V or less
2	Line pressure solenoid valve (with dropping resistor)	When releasing accelerator pedal after warming up engine.	5 - 14V
		When depressing accelerator pedal fully after warming up engine.	0.5V or less
3	O/D OFF indicator lamp	When setting overdrive control switch in "OFF" position.	1V or less
		When setting overdrive control switch in "ON" position.	Battery voltage
4	Power source	When turning ignition switch to "ON".	Battery voltage
		When turning ignition switch to "OFF".	1V or less

GI
 MA
 EM
 LC
 EC
 FE
 CL
 MT
AT
 TF
 PD
 FA
 RA
 BR
 ST
 RS
 BT
 PA
 EL
 DX

TROUBLE DIAGNOSIS FOR DTC P0720

Vehicle Speed Sensor-A/T (Revolution sensor) (Cont'd)

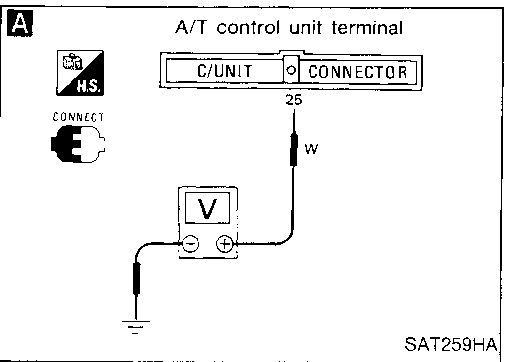
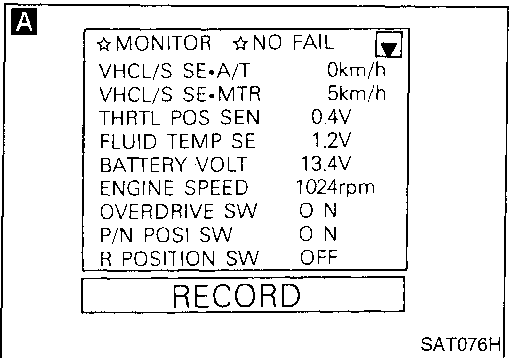
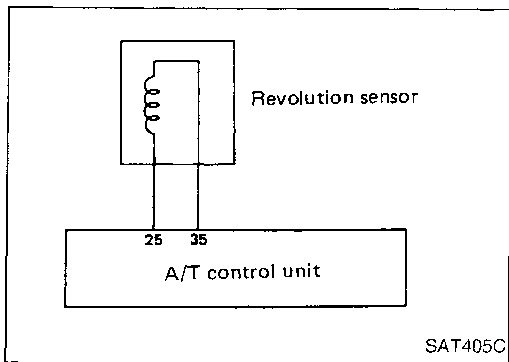

CHECK REVOLUTION SENSOR.
Refer to "Component Inspection" below.

OK →

CHECK INPUT SIGNAL.

- Start engine.
- Select "ECU INPUT SIGNALS" in Data Monitor.
- Read out the value of "VHCL/S SE-A/T" while driving. Check the value changes according to driving speed.

OR

- Start engine.
- Check voltage between A/T control unit terminal 25 and ground while driving. (Measure with AC range.)

Voltage:
At 0 km/h (0 MPH): 0V
At 30 km/h (19 MPH): 1V or more
(Voltage rises gradually in response to vehicle speed.)

NG → Repair or replace revolution sensor.

Check the following items:

- Harness for short or open between A/T control unit and revolution sensor (Main harness)
- Harness for short or open between revolution sensor and ECM (Main harness)
- Ground circuit for ECM Refer to EC section ("TROUBLE DIAGNOSIS FOR POWER SUPPLY").

OK → Perform Diagnostic Trouble Code (DTC) confirmation procedure, AT-64.

OK → **INSPECTION END**

NG →

- Perform A/T control unit input/output signal inspection.
- If NG, recheck A/T control unit pin terminals for damage or loose connection with harness connector.

COMPONENT INSPECTION

Revolution sensor

- For removal, refer to AT-132.
- Check resistance between terminals ①, ② and ③.

Terminal No.		Resistance
①	②	500 - 650Ω
②	③	No continuity
①	③	No continuity

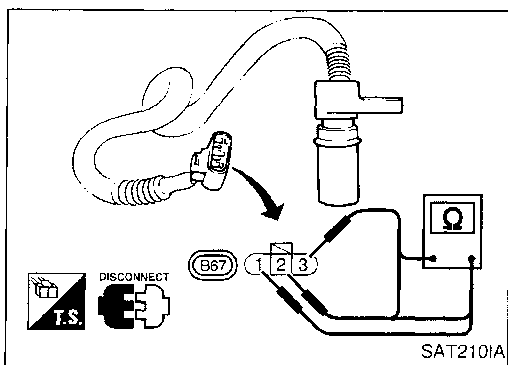

CI
MA
EM
LC
EC
FE
CL
MT
AT
TF
PD
FA
RA
BR
ST
RS
BT
HA
EL
IDX

TROUBLE DIAGNOSIS FOR DTC P0734

Improper Shifting to 4th Gear Position (Cont'd) COMPONENT INSPECTION

Solenoid valves

- For removal, refer to AT-132.

Resistance check

- Check resistance between two terminals.

Solenoid valve	Terminal No.	Resistance (Approx.)
Shift solenoid valve A	③	20 - 40Ω
Shift solenoid valve B	②	
Overrun clutch solenoid valve	④	
Line pressure solenoid valve	⑥	2.5 - 5Ω
Torque converter clutch solenoid valve	⑦	10 - 16Ω

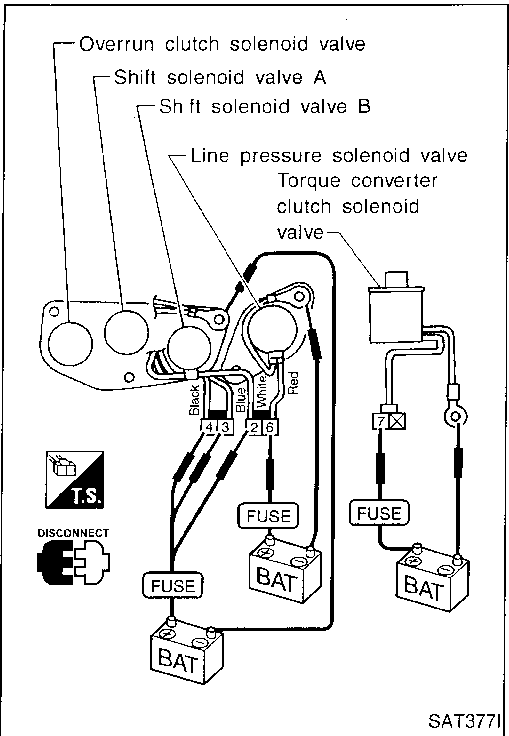
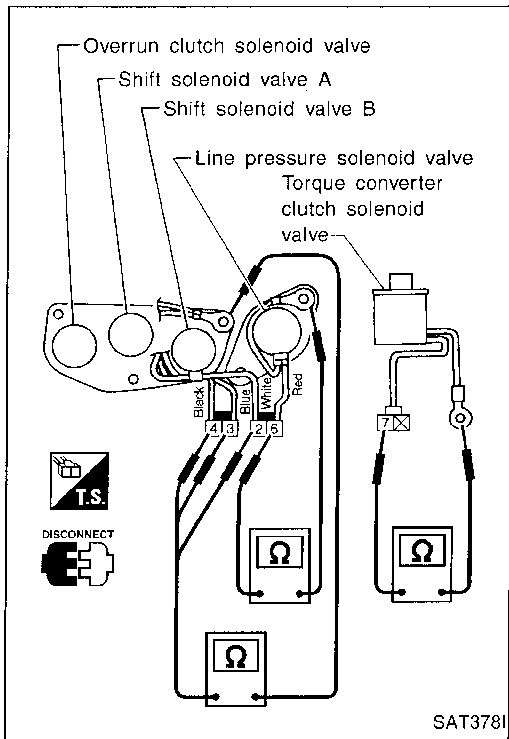

Operation check

- Check solenoid valve by listening for its operating sound while applying battery voltage to the terminal and ground.

GI

MA

EM

LC

EC

FE

CL

MT

AT

TF

PD

FA

RA

BR

ST

RS

BT

HA

EL

DX

TROUBLE DIAGNOSIS FOR DTC P0750

Shift Solenoid Valve A (Cont'd)

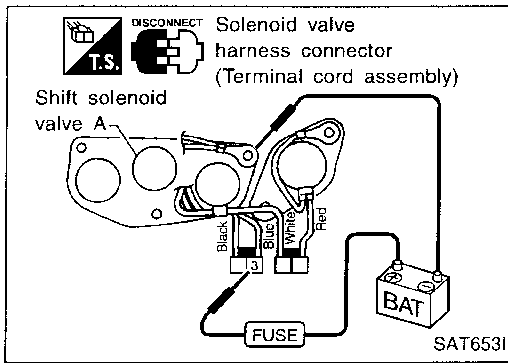

Operation check

- Check solenoid valve by listening for its operating sound while applying battery voltage to the terminal and ground.

GI

MA

EM

LC

EC

FE

CL

MT

AT

TF

PD

FA

RA

BR

ST

RS

BT

HA

EL

DX

5. Large Shock. "N" → "R" Position

SYMPTOM:

There is large shock when changing from "N" to "R" position.

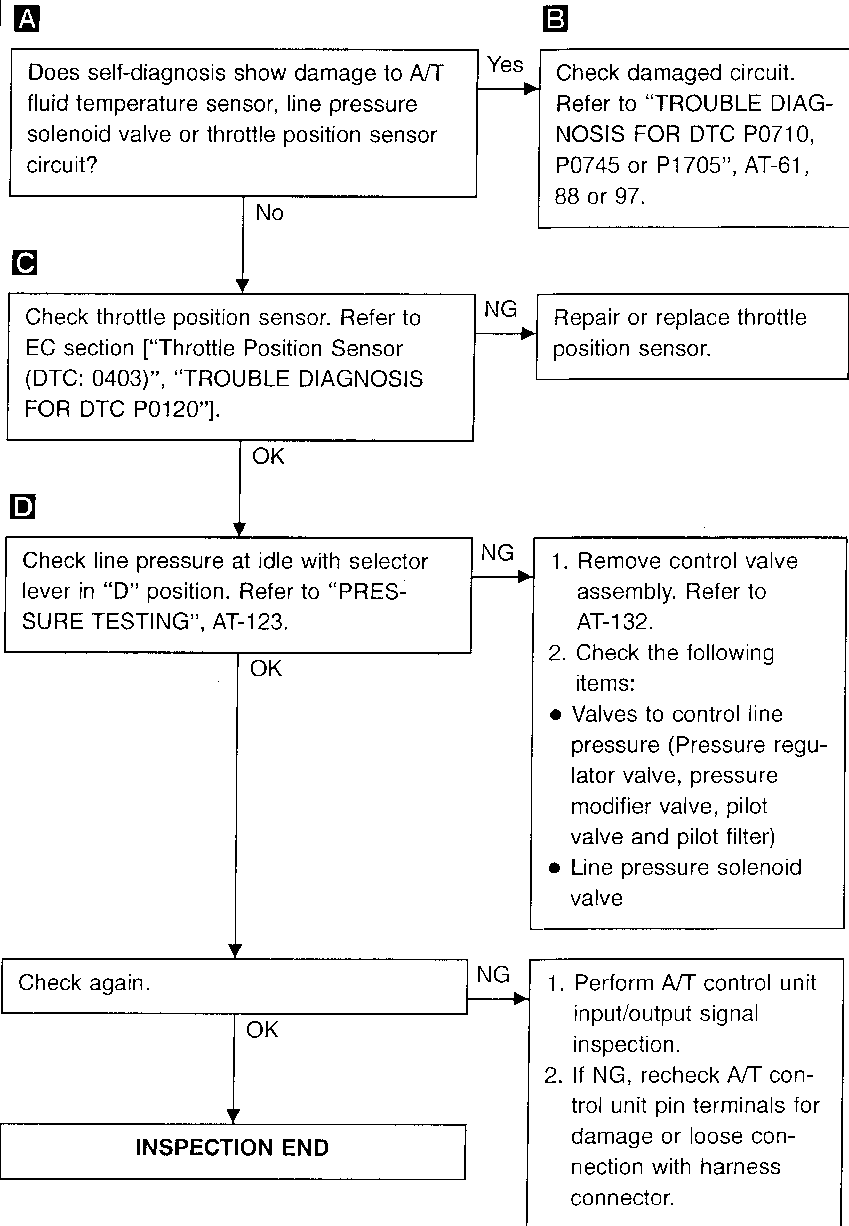
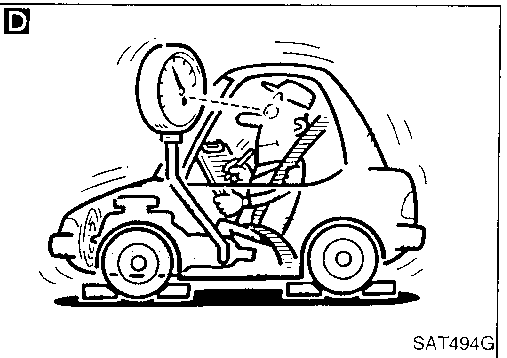
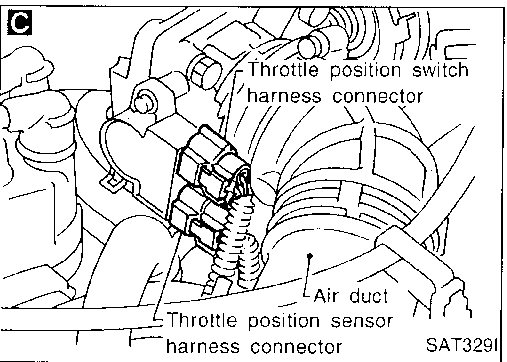
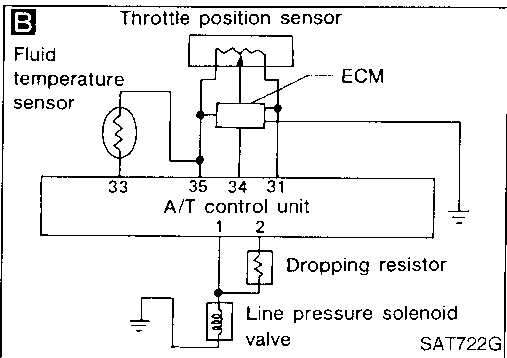
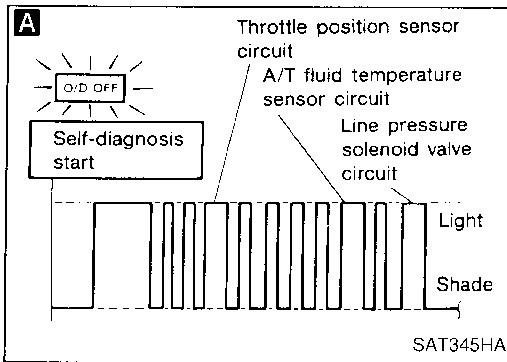

GI
 MA
 EM
 IC
 EC
 FE
 CL
 MT
AT
 TF
 PD
 FA
 RA
 BR
 ST
 RS
 BT
 HA
 EL
 IDX

TROUBLE DIAGNOSES

Final Check (Cont'd)

JUDGEMENT OF STALL TEST

The test result and possible damaged components relating to each result are shown in the illustration. In order to pinpoint the possible damaged components, follow the WORK FLOW shown in AT-34.

Note

Stall revolution is too high in "D" or "2" position:

- Slippage occurs in 1st gear but not in 2nd and 3rd gears. Low one-way clutch slippage
- Slippage occurs at the following gears:
 - 1st through 3rd gears in "D" position and engine brake functions.
 - 1st and 2nd gears in "2" position and engine brake functions with accelerator pedal released (fully closed throttle). Forward clutch or forward one-way clutch slippage

Stall revolution is too high in "R" position:

- Engine brake does not function in "1" position. Low & reverse brake slippage
- Engine brake functions in "1" position. Reverse clutch slippage

Stall revolution within specifications:

- Vehicle does not achieve speed of more than 80 km/h. One-way clutch seizure in torque converter housing

CAUTION:

Be careful since automatic fluid temperature increases abnormally.

- Slippage occurs in 3rd and 4th gears in "D" position. High clutch slippage
- Slippage occurs in 2nd and 4th gear in "D" position. Brake band slippage

Stall revolution less than specifications:

- Poor acceleration during starts. One-way clutch seizure in torque converter

GI

MA

EM

LC

EC

FE

CL

MT

AT

TF

PD

FA

RA

BR

ST

RS

BT

HA

EL

IDX

REMOVAL AND INSTALLATION

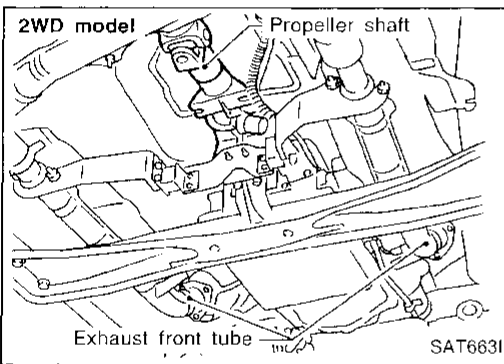
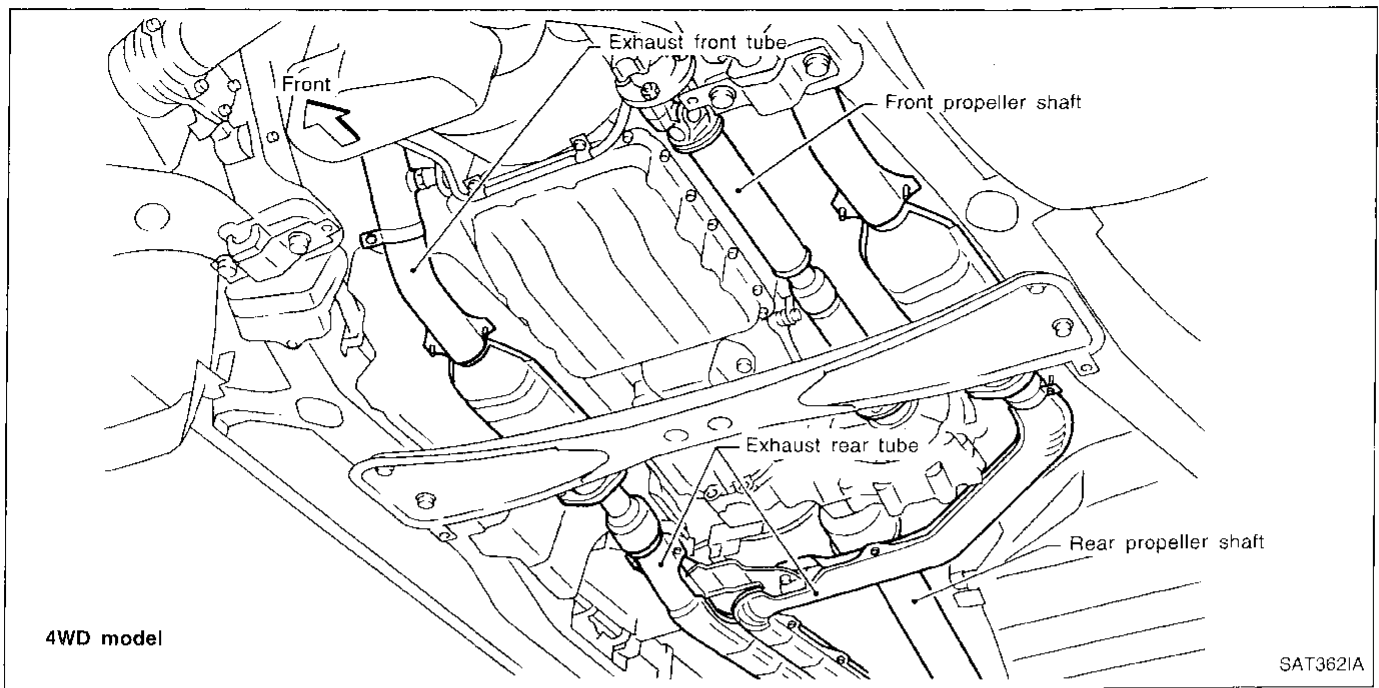

Removal

CAUTION:

When removing the A/T assembly from engine, first remove the crankshaft position sensor (OBD) from the A/T assembly upper side.

Be careful not to damage sensor edge.

— 4WD and 2WD model —

1. Remove battery negative terminal.
2. Remove exhaust front and rear tubes.
3. Remove fluid charging pipe from A/T assembly.
4. Remove oil cooler pipe from A/T assembly.
5. Plug up openings such as the fluid charging pipe hole, etc.
6. Remove propeller shaft. Refer to PD section ("Removal", "PROPELLER SHAFT").
7. Remove transfer control linkage from transfer. Refer to TF section ("Removal" — "REMOVAL AND INSTALLATION").

- Insert plug into rear oil seal after removing rear propeller shaft.
 - Be careful not to damage spline, sleeve yoke and rear oil seal.
8. Remove A/T control cable from A/T assembly.
 9. Disconnect A/T and speedometer sensor harness connectors.
 10. Remove starter motor.

Tightening torque

□: 41 - 52 N·m (4.2 - 5.3 kg-m, 30 - 38 ft-lb)

11. Remove gusset and rear plate cover securing engine to A/T assembly.
 12. Remove bolts securing torque converter to drive plate.
- Remove the bolts by turning crankshaft.

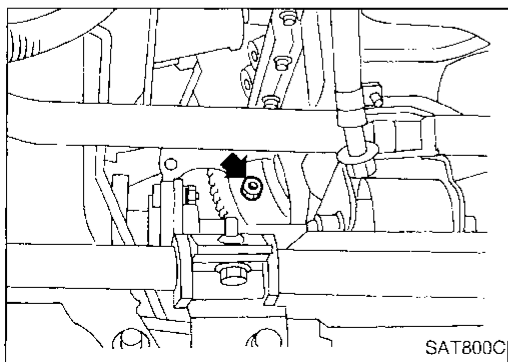

CI
MA
EM
LC
EC
FE
CL
MT
AT
TF
PD
SA
RA
BR
ST
RS
BT
HA
EL
DX

DISASSEMBLY

Disassembly (Cont'd)

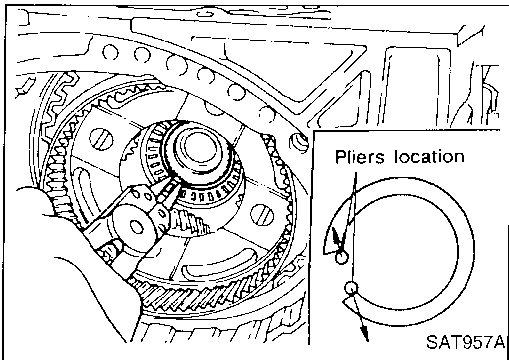

- b. Slowly push output shaft all the way forward.
- **Do not use excessive force.**
- c. Remove snap ring from output shaft.

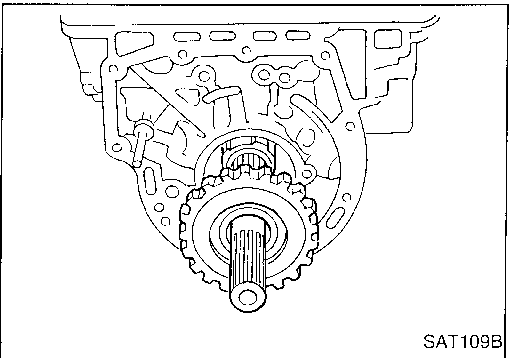

- d. Remove output shaft and parking gear as a unit from transmission case.
- e. Remove parking gear from output shaft.

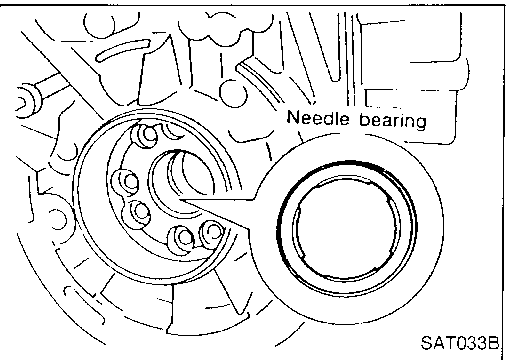

- f. Remove needle bearing from transmission case.

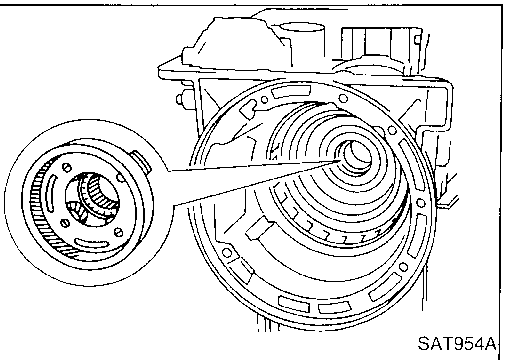

- 20. Remove rear side clutch and gear components.
- a. Remove front internal gear.

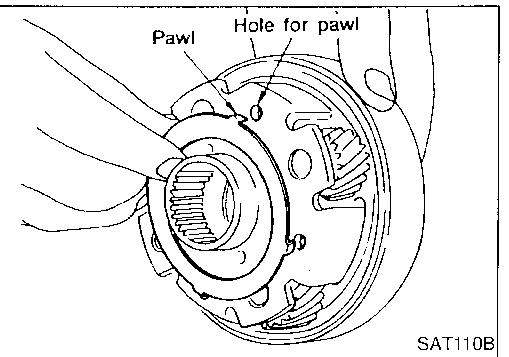

- b. Remove bearing race from front internal gear.

GI

MA

EM

LC

EC

FE

CL

ME

AT

TF

PC

FA

RA

BR

ST

RS

BT

FIA

EL

IDX

Control Valve Upper Body

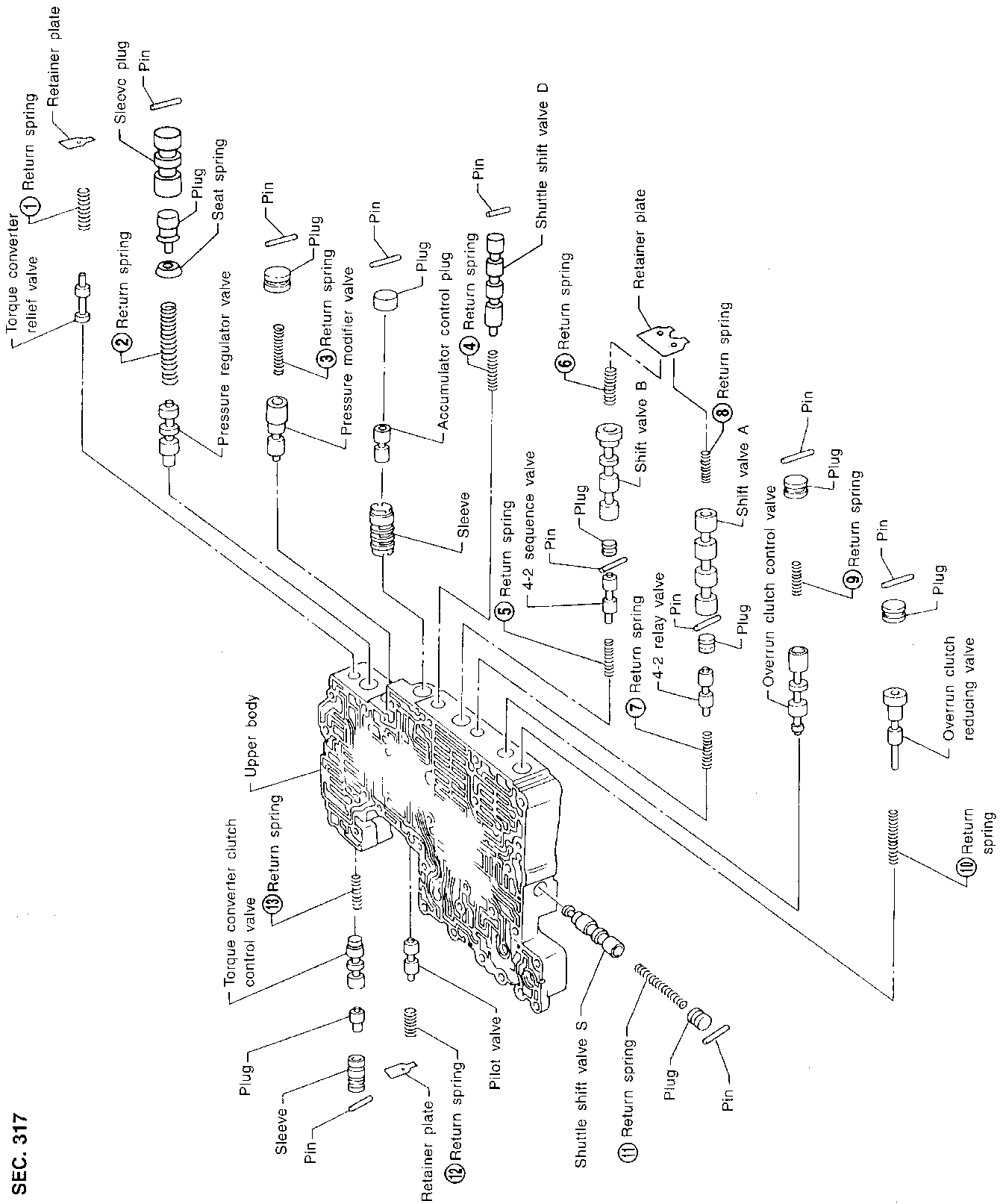

SEC. 317

Apply ATF to all components before their installation.

Numbers preceding valve springs correspond with those shown in SDS on page AT-215.

- GI
- MA
- EM
- EG
- EC
- FE
- CL
- MT
- AT**
- TF
- PD
- FA
- BA
- BR
- ST
- FS
- BT
- HA
- EL
- DX

REPAIR FOR COMPONENT PARTS

Forward and Overrun Clutches (Cont'd)

DISASSEMBLY AND ASSEMBLY

Forward and overrun clutches are serviced essentially the same way as reverse clutch is serviced. However, note the following exceptions.

- Check of forward clutch operation.

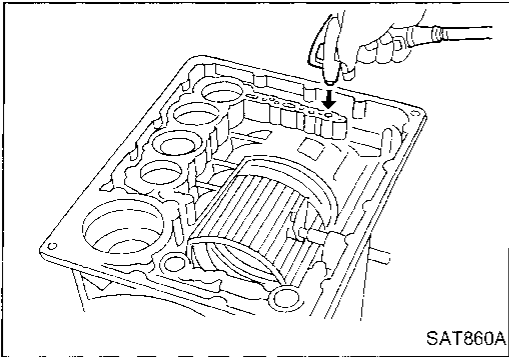

SAT860A

- Check of overrun clutch operation.

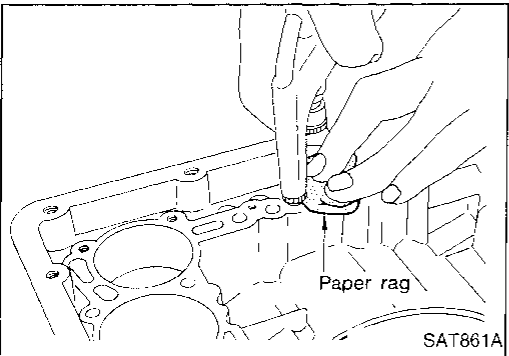

SAT861A

- Removal of forward clutch drum
Remove forward clutch drum from transmission case by holding snap ring.

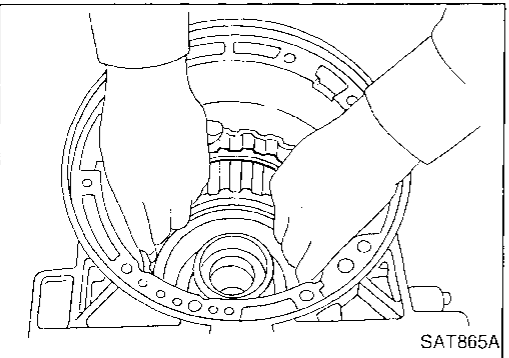

SAT865A

- Removal of forward clutch and overrun clutch pistons
1. While holding overrun clutch piston, gradually apply compressed air to oil hole.

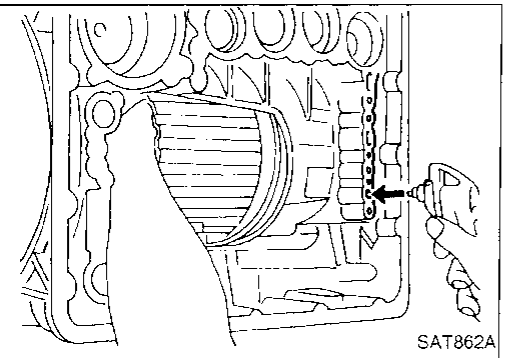

SAT862A

2. Remove overrun clutch from forward clutch.

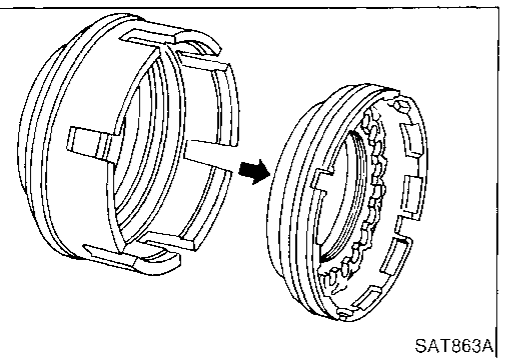

SAT863A

GI

MA

EV

LC

EC

FE

CL

MT

AT

TF

PD

FA

RA

BR

ST

RS

BT

HA

EL

DX

REPAIR FOR COMPONENT PARTS

Band Servo Piston Assembly (Cont'd)

ASSEMBLY

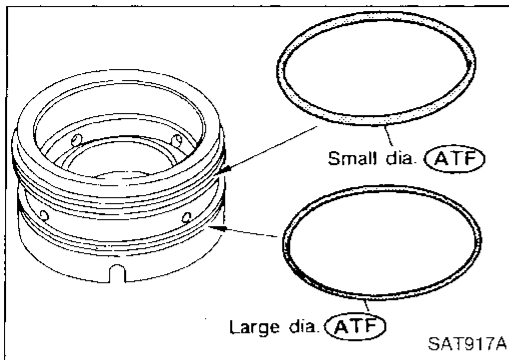

1. Install O-rings onto servo piston retainer.
 - Apply ATF to O-rings.
 - Pay attention to position of each O-ring.

GI

MA

EM

LC

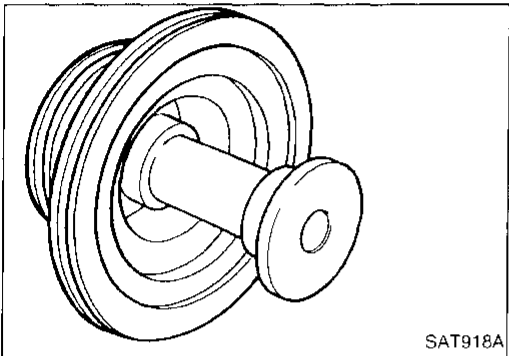

2. Install servo cushion spring retainer onto band servo piston.

EC

FE

CL

MT

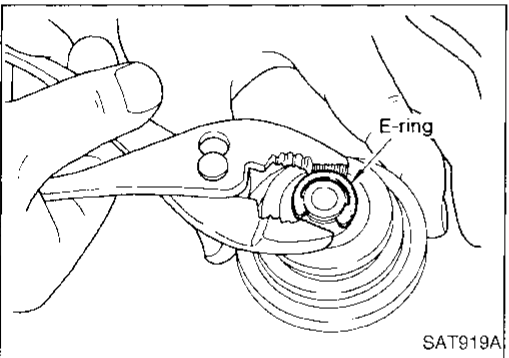

3. Install E-ring onto servo cushion spring retainer.

AT

TF

PD

FA

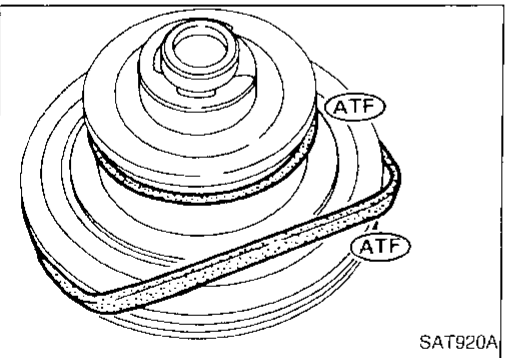

4. Install D-rings onto band servo piston.
 - Apply ATF to D-rings.

RA

BR

ST

RS

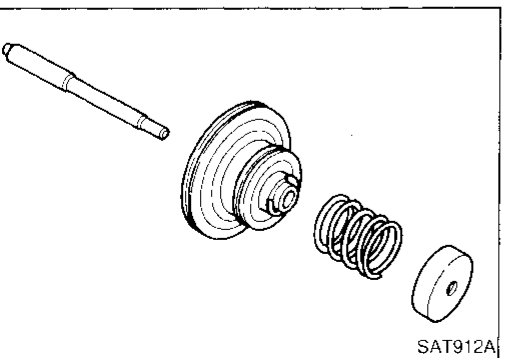

5. Install servo piston spring retainer, return spring C and piston stem onto band servo piston.

BT

EA

EL

IDX

ASSEMBLY

Assembly (2) (Cont'd)

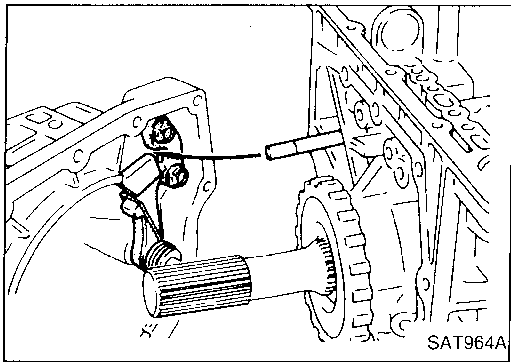

e. Install parking rod on transmission case.

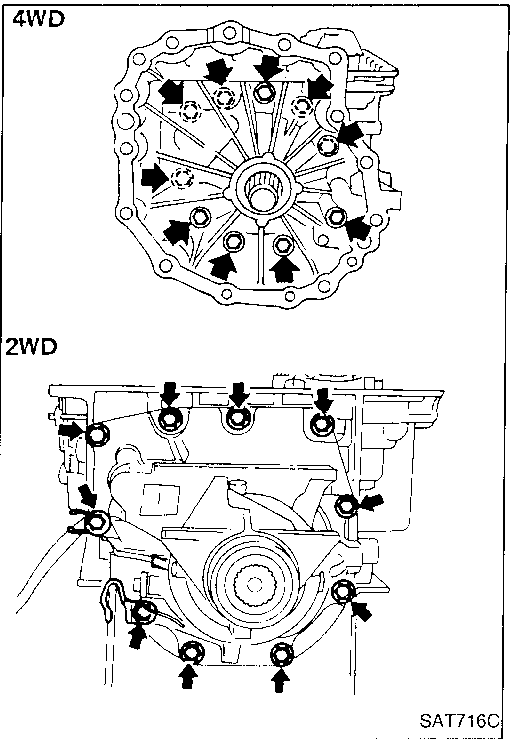

f. Install rear extension or adapter case on transmission case.

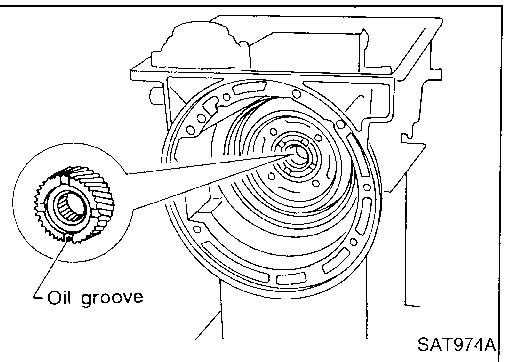

3. Install front side clutch and gear components.

a. Install rear sun gear on transmission case.

- Pay attention to its direction.

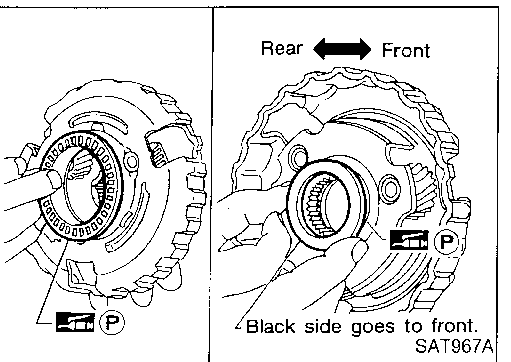

b. Make sure needle bearing is on front of front planetary carrier.

- Apply petroleum jelly to needle bearing.

c. Make sure needle bearing is on rear of front planetary carrier.

- Apply petroleum jelly to bearing.
- Pay attention to its direction — Black side goes to front.

GI

MA

EM

LC

EC

FE

CL

MT

AT

TF

PD

FA

RA

BR

ST

RS

BT

HA

EL

IDX

CONTENTS (Cont'd)

Diagnostic Procedure 9 (Unexpected pedal action).....70	Diagnostic Procedure 13 (Warning lamp does not come on when ignition switch is turned on.).....72	GI
Diagnostic Procedure 10 (Long stopping distance).....70	Diagnostic Procedure 14 (Warning lamp stays on when ignition switch is turned on.).....74	MA
Diagnostic Procedure 11 (ABS does not work.).....71	SERVICE DATA AND SPECIFICATIONS (SDS).....77	
Diagnostic Procedure 12 (Pedal vibration and noise).....71	General Specifications.....77	EM
	Inspection and Adjustment.....78	

When you read wiring diagrams:

- Read GI section, "HOW TO READ WIRING DIAGRAMS".
- See EL section, "POWER SUPPLY ROUTING" for power distribution circuit.

When you perform trouble diagnoses, read GI section, "HOW TO FOLLOW FLOW CHART IN TROUBLE DIAGNOSES" and "HOW TO PERFORM EFFICIENT DIAGNOSIS FOR AN ELECTRICAL INCIDENT".

GI
MA
EM
LC
EC
FE
CL
MT
AT
TF
PD
FA
RA
BR
ST
RS
BT
HA
EL
IDX

MASTER CYLINDER

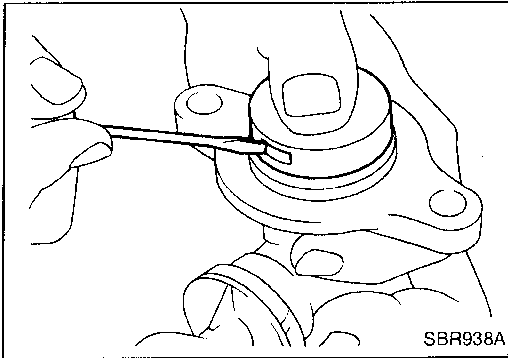

Disassembly

1. Bend claws of stopper cap outward.

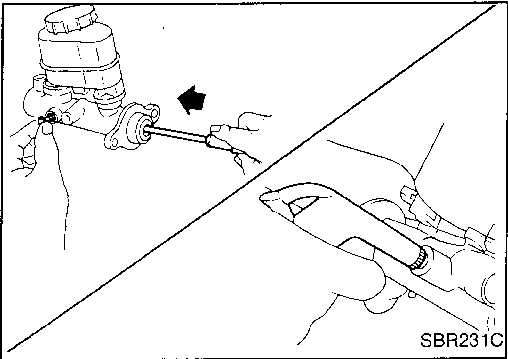

2. Remove piston stopper while piston is pushed into cylinder (Models with ABS only).
3. Remove piston assemblies.

If it is difficult to remove secondary piston assembly, gradually apply compressed air through fluid outlet.

4. Draw out reservoir tank.

Inspection

Check master cylinder inner wall for pin holes or scratches. Replace if damaged.

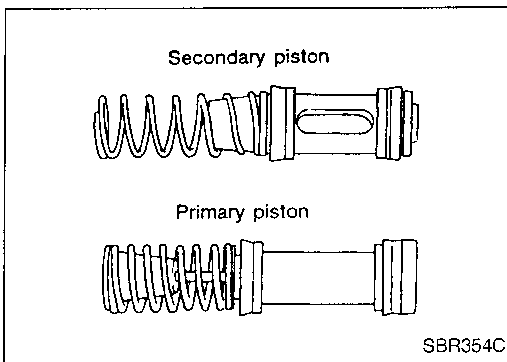

Assembly

1. Insert secondary piston assembly. Then insert primary piston assembly.

- Pay attention to direction of piston cups in figure at left. Also, insert pistons squarely to avoid scratches on cylinder bore.
- Pay attention to alignment of secondary piston slit with valve stopper mounting hole of cylinder body (Models with ABS only).

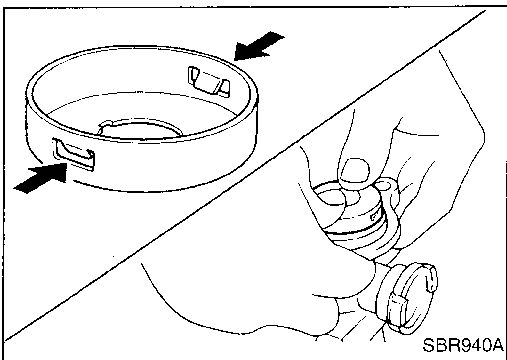

2. Install stopper cap.

Before installing stopper cap, ensure that claws are bent inward.

3. Push reservoir tank seals into cylinder body.
4. Push reservoir tank into cylinder body.

GI

MA

EM

LC

EC

FE

CL

MT

AT

TF

PD

FA

RA

BR

ST

RS

BT

HA

EL

IDX

PARKING BRAKE CONTROL

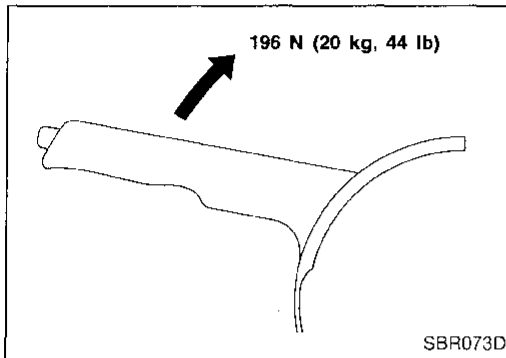
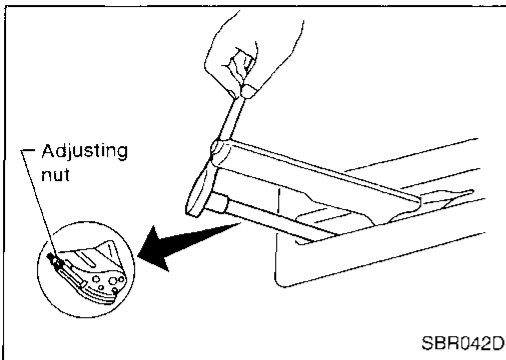

Adjustment

1. Adjust clearance between shoe and drum as follows:
 - a. Release parking brake lever and loosen adjusting nut.
 - b. Depress brake pedal fully at least 10 times with engine running.
2. Pull control lever 4 - 5 notches. Then adjust control lever by turning adjusting nut.

3. Pull control lever with specified amount of force. Check lever stroke and ensure smooth operation.

Number of notches: 6 - 8

4. Bend warning lamp switchplate to ensure:
 - Warning lamp comes on when lever is lifted "A" notches.
 - Warning lamp goes out when lever is fully released.

Number of "A" notches : 1 or less

GI

MA

EM

LC

EC

FE

CL

MT

AT

TF

PD

FA

RA

BR

ST

RS

BT

HA

EL

IDX

TROUBLE DIAGNOSES FOR SELF-DIAGNOSTIC ITEMS

Diagnostic Procedure 1 (Wheel sensor or rotor) (Cont'd)

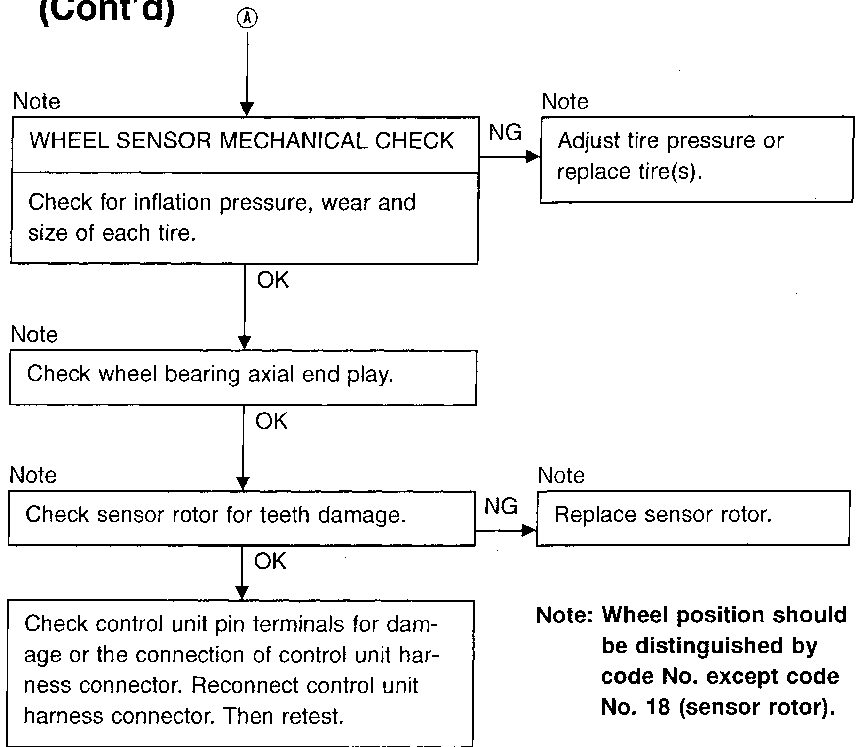

GF

MA

EM

LC

EC

FE

CL

MT

AT

TF

PD

FA

RA

BR

ST

RS

BT

HA

EL

IDX

Diagnostic Procedure 11 (ABS does not work.)

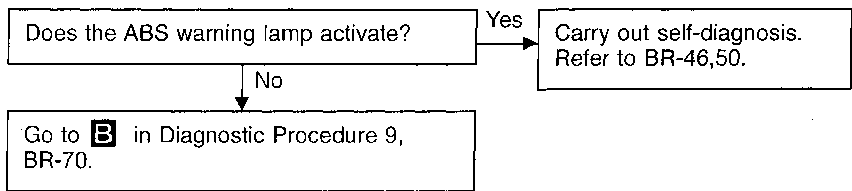

Note: ABS does not work when vehicle speed is under 10 km/h (6 MPH).

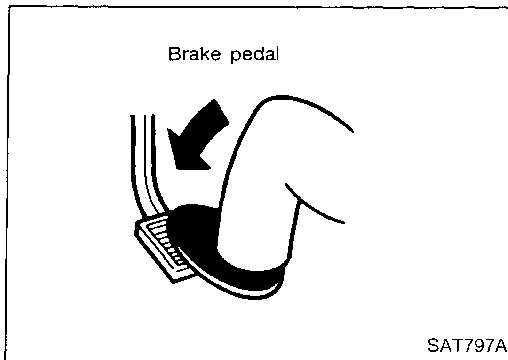

Diagnostic Procedure 12 (Pedal vibration and noise)

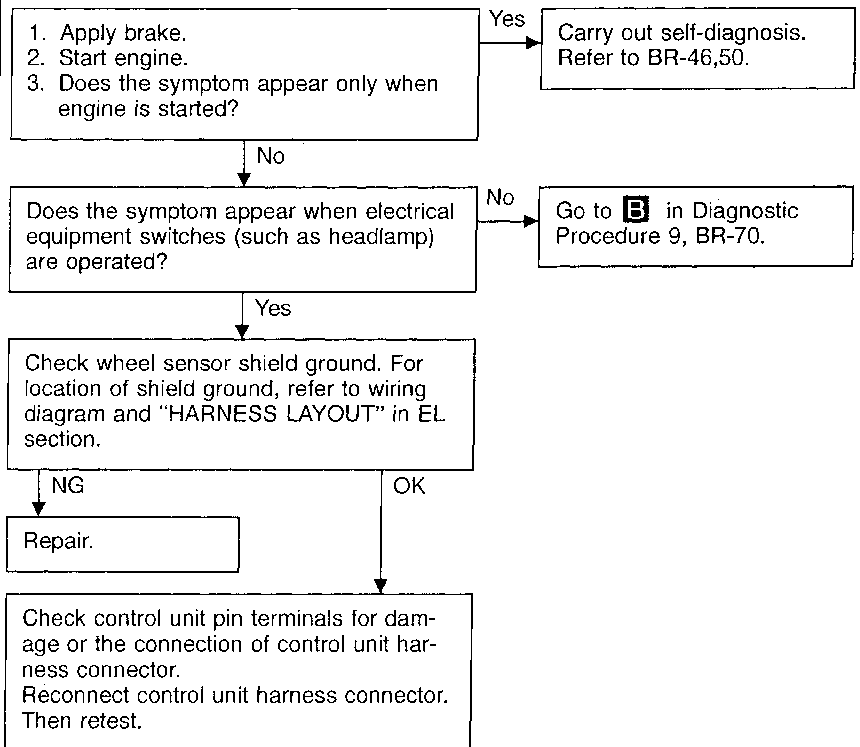

Note: ABS may operate and cause vibration under any of the following conditions.

- Applying brake gradually when shifting or operating clutch.
- Low friction (slippery) road.
- High speed cornering.
- Driving over bumps and pot holes.
- Engine speed is over 5,000 rpm with vehicle stopped.

GI
MA
EM
LC
EC
FE
CL
MT
AT
TF
PD
FA
RA
BR
ST
RS
BT
HA
EL
IDX

Body Rear End and Opener

- Bumper fascia is made of plastic. Do not use excessive force and be sure to keep oil away from it.
- Back door lock system adjustment: Adjust lock & striker so that they are in the center.
After adjustment, check back door lock operation.
- Back door hatch lock system adjustment: Adjust lock & striker so that they are in the center.
After adjustment, check back door hatch lock operation.
- Opener cable: Do not attempt to bend cable using excessive force.
- After installation, make sure that back door and fuel filler lid open smoothly.

WARNING:

- Be careful not to scratch back door stay and/or back door hatch stay when installing back door and/or back door hatch. A scratched stay may cause gas leakage.
- The contents of the back door stay and back door hatch stay are under pressure. Do not take apart, puncture, apply heat or allow fire near them.

REMOVAL — Rear bumper assembly

- ① Remove screws securing left and right mudguards and remove the mudguards.
- ② Remove clips (C103) and screws securing left and right sides of wheel protector.
- ③ Remove bolts from lower side of bumper assembly.
- ④ Remove bolts securing bumper rubber assembly.
- ⑤ Remove bolts securing spare tire hanger striker assembly.
- ⑥ Remove bolts securing spare tire hanger guide assembly.
- ⑦ Remove clips (C205) from upper side of bumper assembly.
- ⑧ Extract bumper assembly.
- ⑨ Remove nuts securing bumper reinforcement and remove the bumper reinforcement.

SEC. 570•767•850•900•905

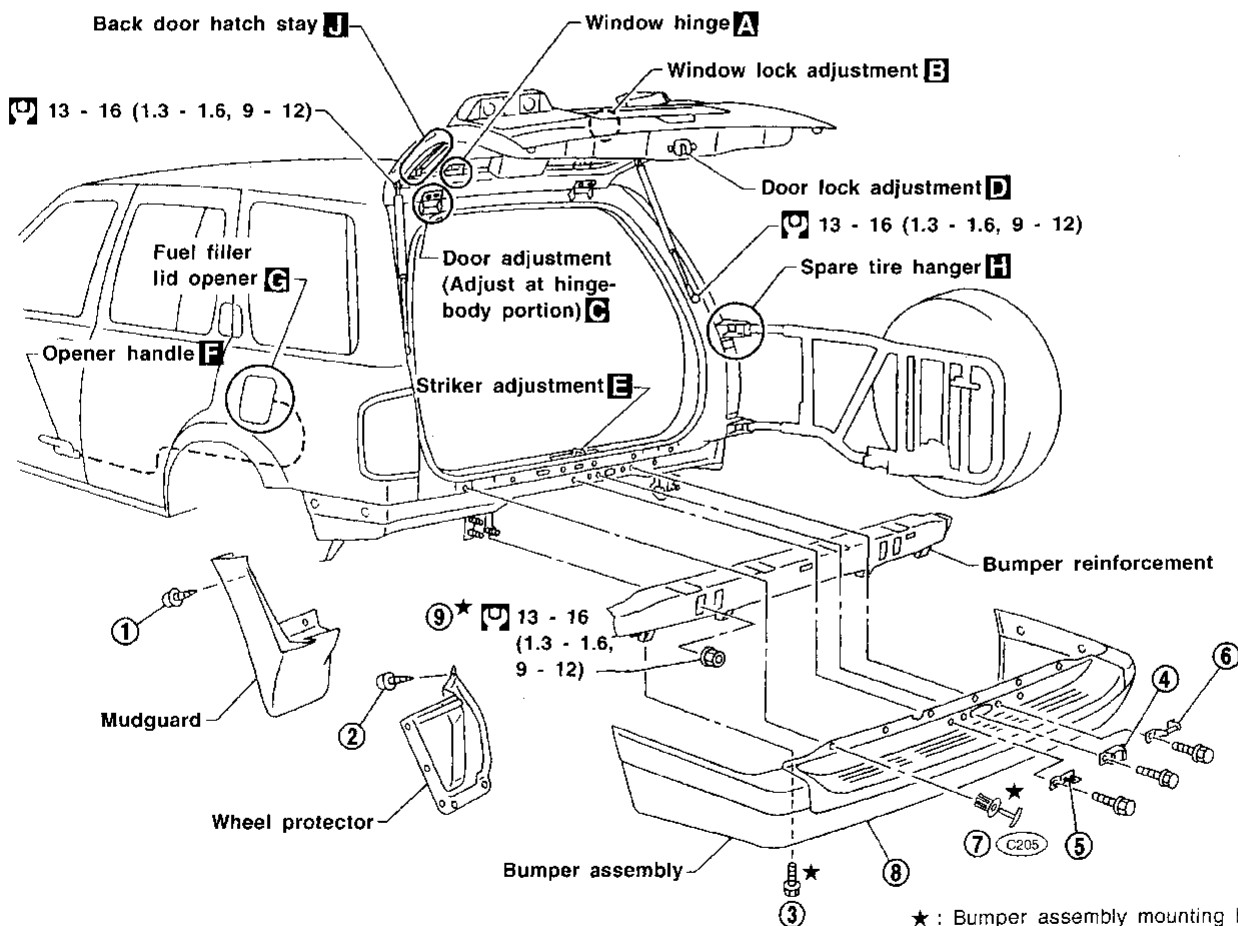

★ : Bumper assembly mounting bolts, nuts and clips.

Ⓞ : N·m (kg-m, ft-lb)

SBT200

⑤ Windshield upper molding

SEC. 720

1. Cut off sealant at glass end.
2. Clean the side on which panel was mounted.
3. Set molding fastener and apply primer to body panel, and apply sealant to body.

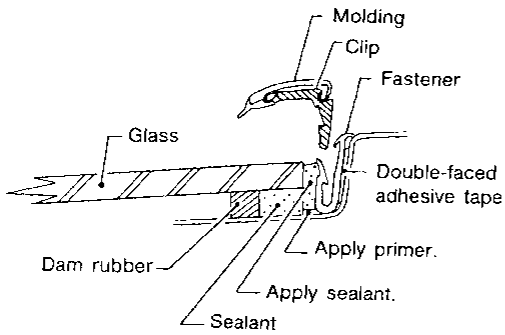
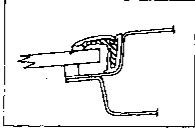

4. Install molding by aligning the molding mark located on center with vehicle center. Be sure to install tightly so that there is no gap around the corner.

SBF342H

⑦ Drip weatherstrip

SEC. 767

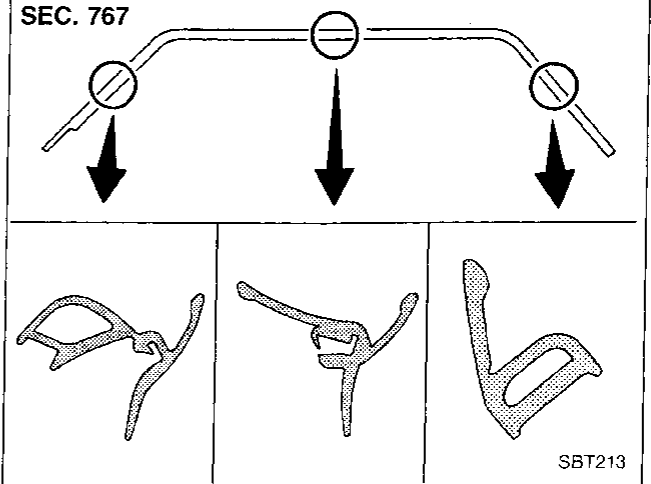

SBT213

⑧ Body side welt

SEC. 769

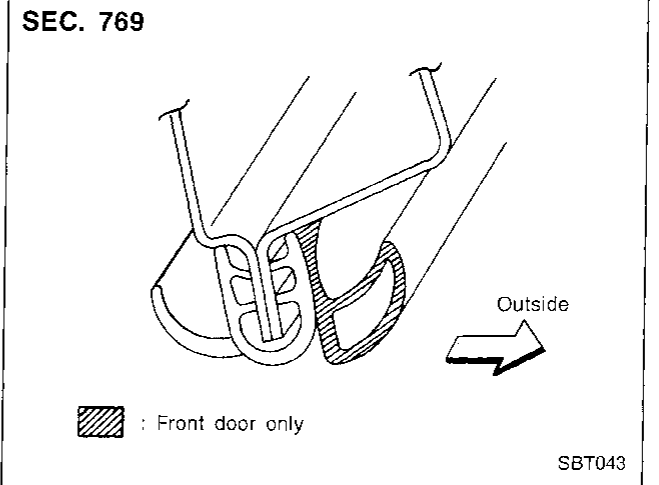

▨ : Front door only

SBT043

⑥ Sunroof lid weatherstrip

SEC. 736

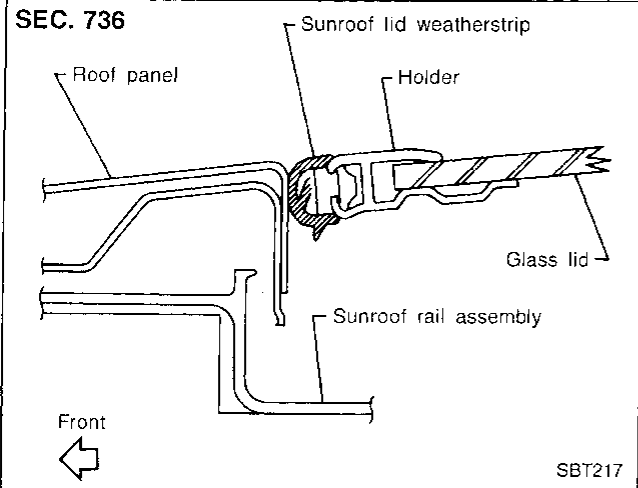

SBT217

⑨ Door weatherstrip

SEC. 800•820

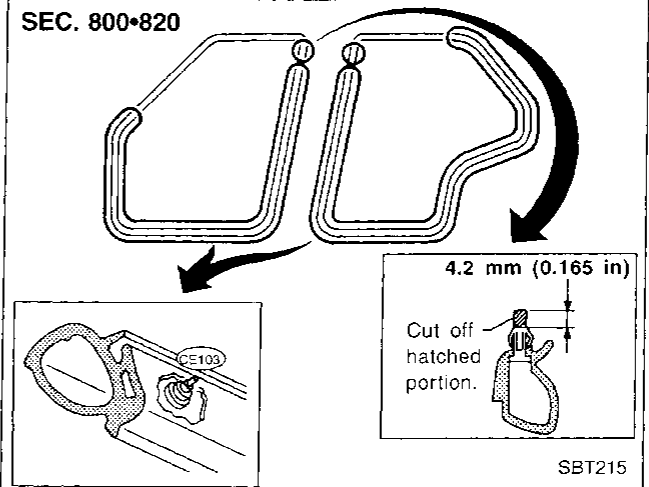

4.2 mm (0.165 in)

Cut off hatched portion.

SBT215

GI
MA
EM
LC
EC
FE
CL
MT
AT
TF
PD
FA
RA
BR
ST
RS
BT
HA
EL
IDX

Rear Side Window

SEC. 830

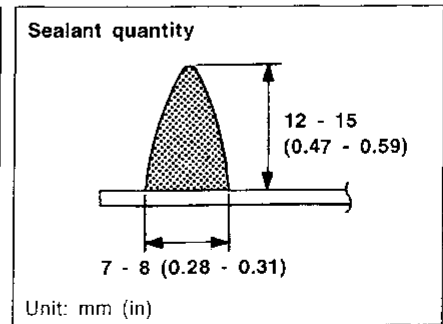
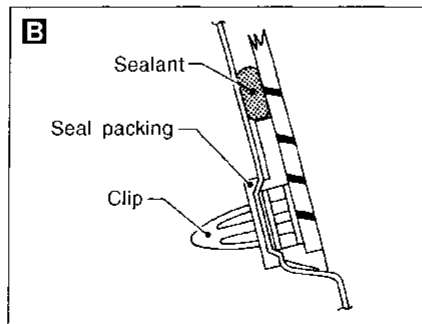
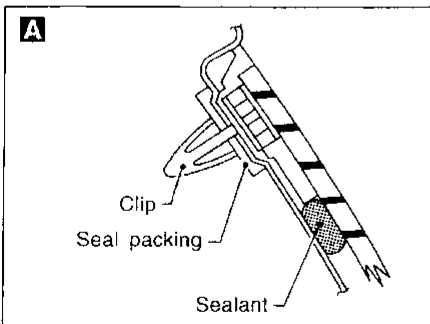
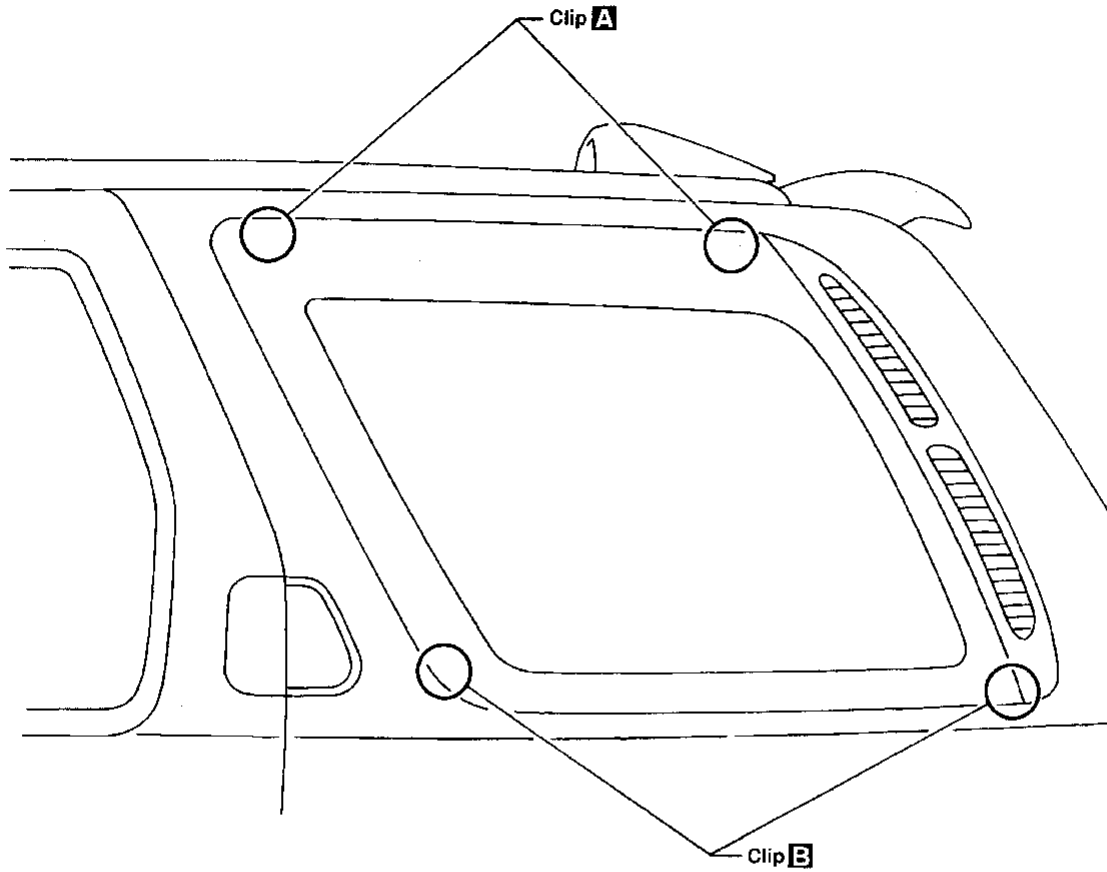

GI
MA
EM
LC
EC
FE
CL
MT
AT
TF
PD
FA
RA
BR
ST
RS
BT
HA
EL
IDX

CLUTCH RELEASE MECHANISM

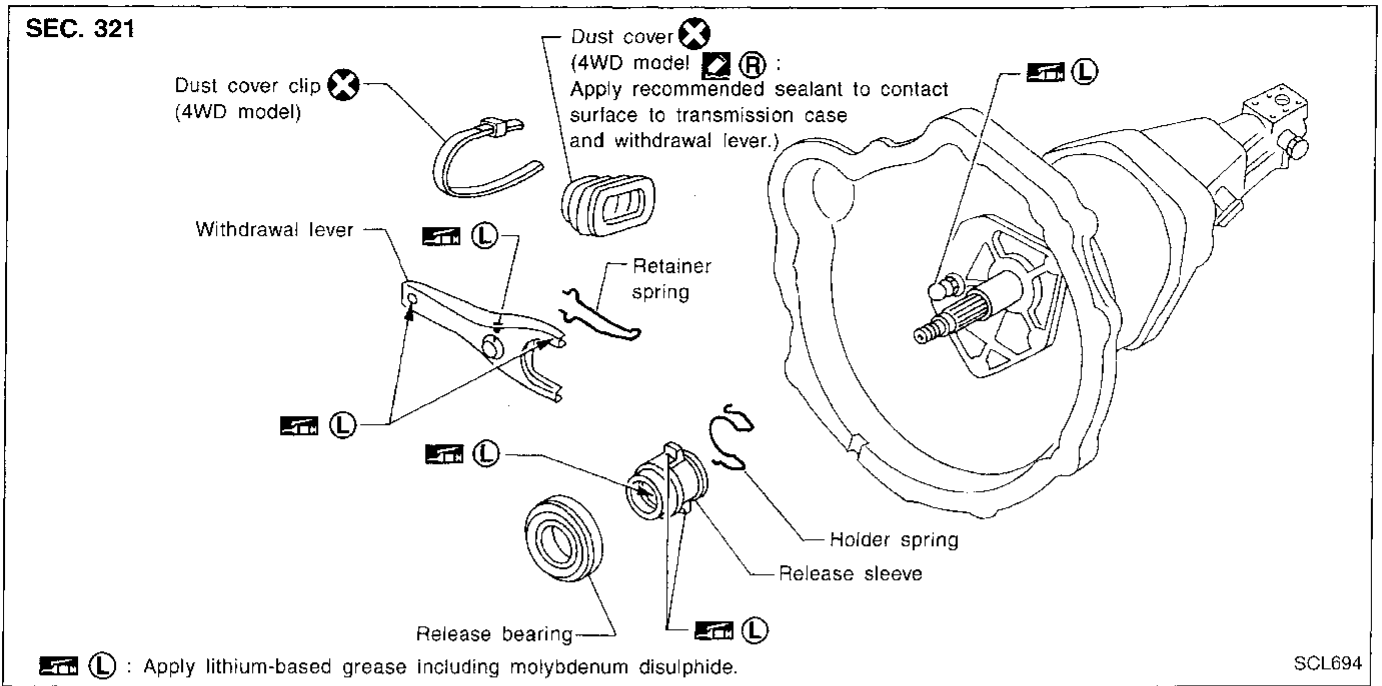

GI
MA
EM
LC
EC
FE
CL

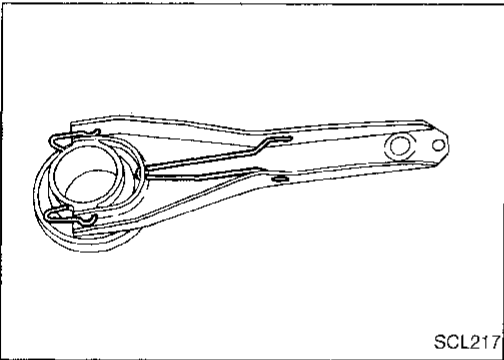

REMOVAL AND INSTALLATION

- Install retainer spring and holder spring.

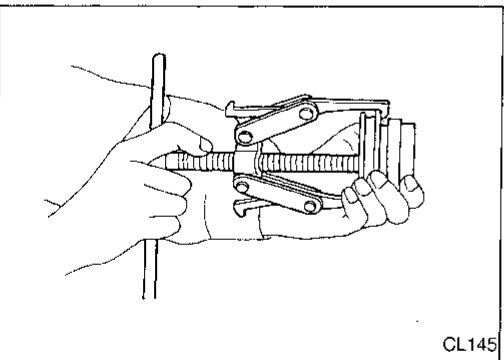

- Remove release bearing.

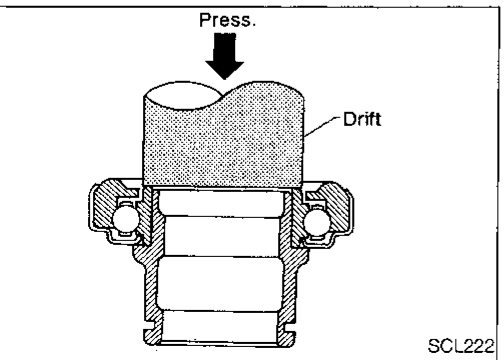

- Install release bearing with suitable drift.

MT
AT
TF
PD
FA
RA
BR
ST
RS
BT
HA
EL
IDX

PRECAUTIONS AND PREPARATION

Precautions (Cont'd)

- When measuring ECM signals with a circuit tester, never allow the two tester probes to contact. Accidental contact of probes will cause a short circuit and damage the ECM power transistor.

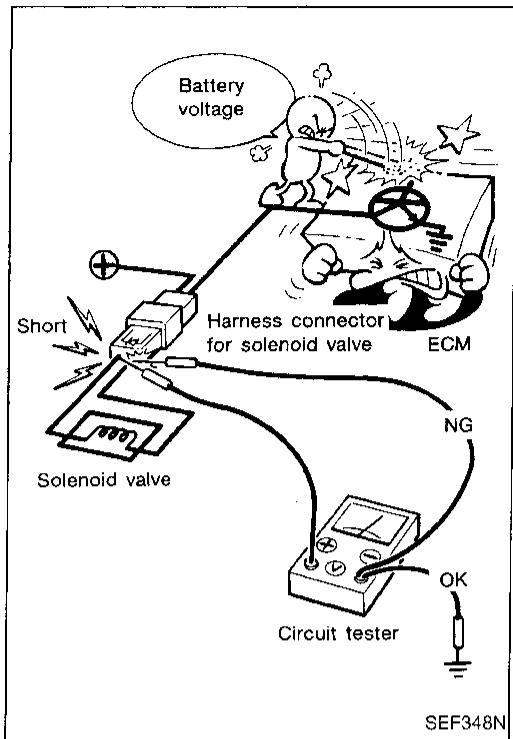

Evaporative Emission Line Drawing

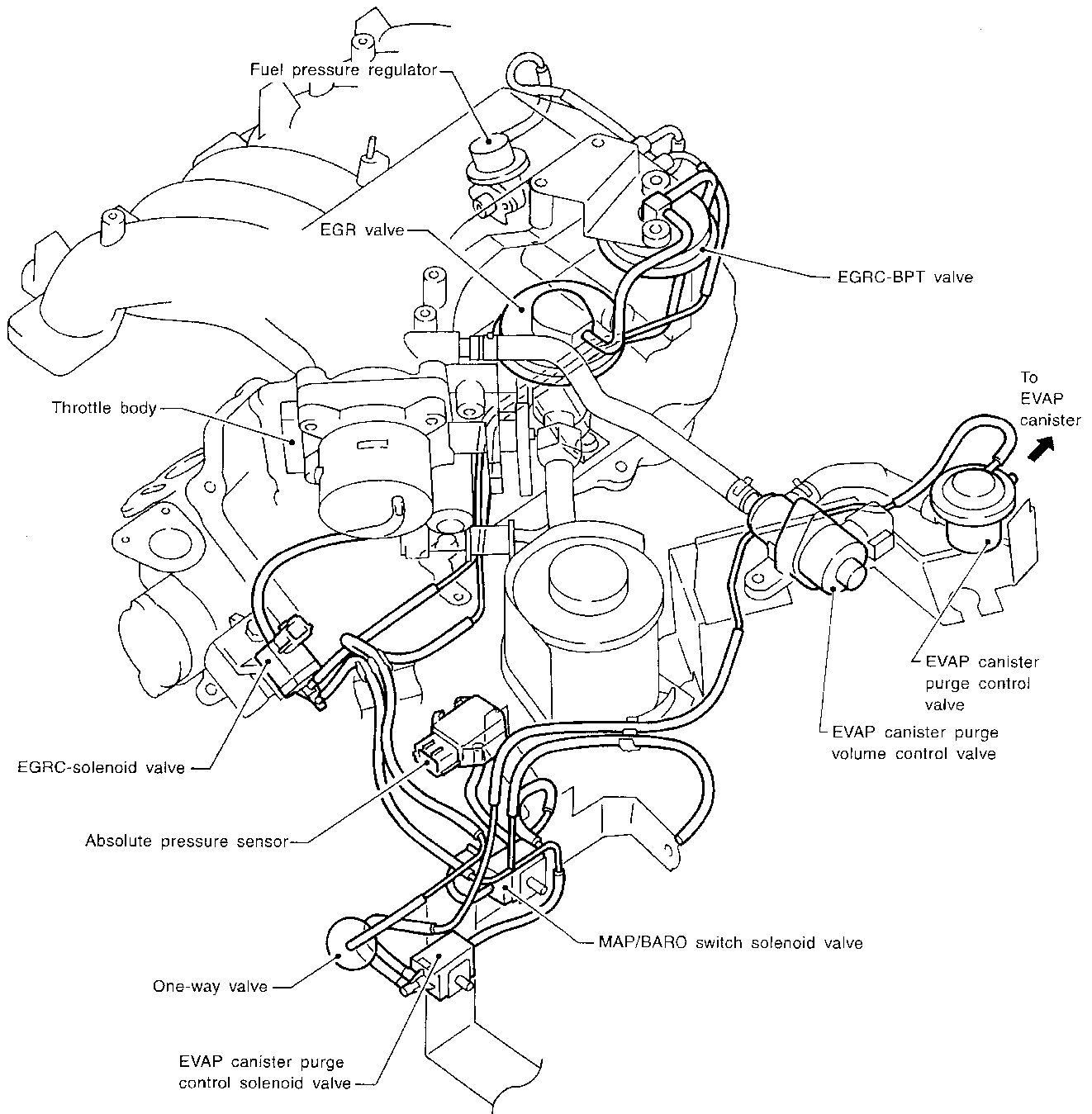

ON BOARD DIAGNOSTIC SYSTEM DESCRIPTION

Introduction

The ECM (ECCS control module) has an on board diagnostic system, which detects malfunctions related to engine sensors or actuators. The ECM also records various emission-related diagnostic information including:

- Diagnostic Trouble Code (DTC)Mode 3 of SAE J1979
- Freeze Frame dataMode 2 of SAE J1979
- System Readiness Test (SRT) codeMode 1 of SAE J1979
- 1st Trip Diagnostic Trouble Code (1st Trip DTC)Mode 7 of SAE J1979
- 1st Trip Freeze Frame data
- Test values and Test limitsMode 6 of SAE J1979

The above information can be checked using procedures listed in the table below.

	DTC	1st trip DTC	Freeze Frame data	1st trip Freeze Frame data	SRT code	Test value
Diagnostic test mode II (Self-diagnostic results)	○	○*1				
CONSULT	○	○	○	○	○	○
GST	○	○*2	○		○	○

*1: When DTC and 1st trip DTC simultaneously appear on the display, they cannot be clearly distinguished from each other.

*2: 1st trip DTCs for self-diagnoses concerning SRT items cannot be shown on the GST display.

The malfunction indicator lamp (MIL) on the instrument panel lights up when the same malfunction is detected in two consecutive trips (Two trip detection logic), or when the ECM enters fail-safe mode (Refer to EC-77.).

Two Trip Detection Logic

When a malfunction is detected for the first time, 1st trip DTC and 1st trip Freeze Frame data are stored in the ECM memory. The MIL will not light up at this stage. (1st trip)

If the same malfunction is detected again during the next drive, the DTC and Freeze Frame data are stored in the ECM memory, and the MIL lights up. The MIL lights up at the same time when the DTC is stored. (2nd trip) The "trip" in the "Two Trip Detection Logic" means a driving mode in which self-diagnosis is performed during vehicle operation. Specific on board diagnostic items will cause the ECM to light up or blink the MIL, and store DTC and Freeze Frame data, even in the 1st trip, as shown below.

Items	MIL			DTC		1st trip DTC	
	1st trip		2nd trip lighting up	1st trip displaying	2nd trip displaying	1st trip displaying	2nd trip displaying
	Blinking	Lighting up					
Misfire (Possible three way catalyst damage) — DTC: P0300 - P0306 (0701, 0603 - 0608) is being detected	X			X		X	
Misfire (Possible three way catalyst damage) — DTC: P0300 - P0306 (0701, 0603 - 0608) has been detected		X		X		X	
Closed loop control — DTC: P0130 (0307), P0150 (0308)		X		X		X	
Fail-safe items (Refer to EC-77.)		X		X*1		X*1	
Except above			X		X	X	X

*1: Except "ECM".

ON BOARD DIAGNOSTIC SYSTEM DESCRIPTION

Malfunction Indicator Lamp (MIL) (Cont'd)

DIAGNOSTIC TEST MODE I—BULB CHECK

In this mode, the MALFUNCTION INDICATOR LAMP on the instrument panel should stay ON. If it remains OFF, check the bulb. Refer to EL section ("WARNING LAMPS AND CHIME") or see EC-341.

DIAGNOSTIC TEST MODE I—MALFUNCTION WARNING

MALFUNCTION INDICATOR LAMP	Condition
ON	When the malfunction is detected or the ECM's CPU is malfunctioning.
OFF	No malfunction.

- These Diagnostic Trouble Code Numbers are clarified in Diagnostic Test Mode II (SELF-DIAGNOSTIC RESULTS).

DIAGNOSTIC TEST MODE II—SELF-DIAGNOSTIC RESULTS

In this mode, the DTC and 1st trip DTC are indicated by the number of blinks of the MALFUNCTION INDICATOR LAMP.

The DTC and 1st trip DTC are displayed at the same time. If the MIL does not illuminate in diagnostic test mode 1 (Malfunction warning), all displayed items are 1st trip DTC's. If only one code is displayed when the MIL illuminates in diagnostic test mode II (SELF-DIAGNOSTIC RESULTS), it is a DTC; if two or more codes are displayed, they may be either DTC's or 1st trip DTC's. DTC No. is same as that of 1st trip DTC. These unidentified codes can be identified by using the consult or GST. A DTC will be used as an example for how to read a code.

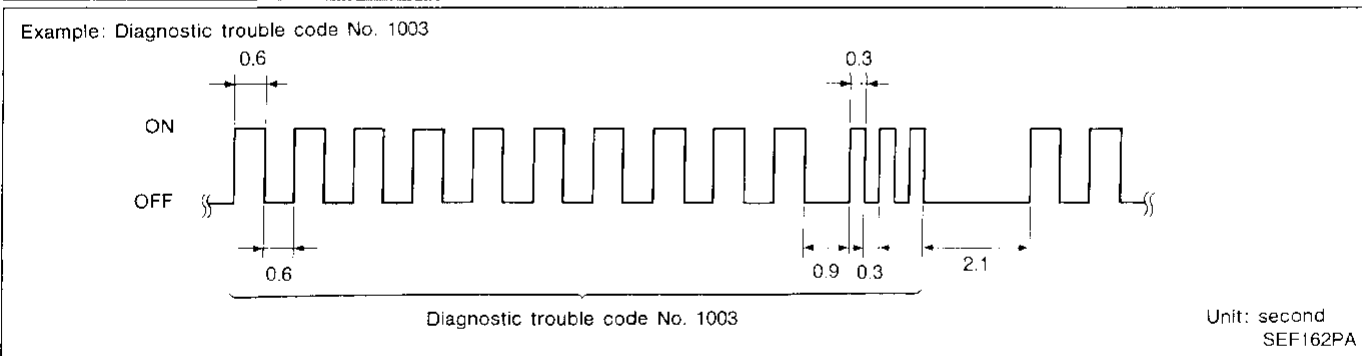
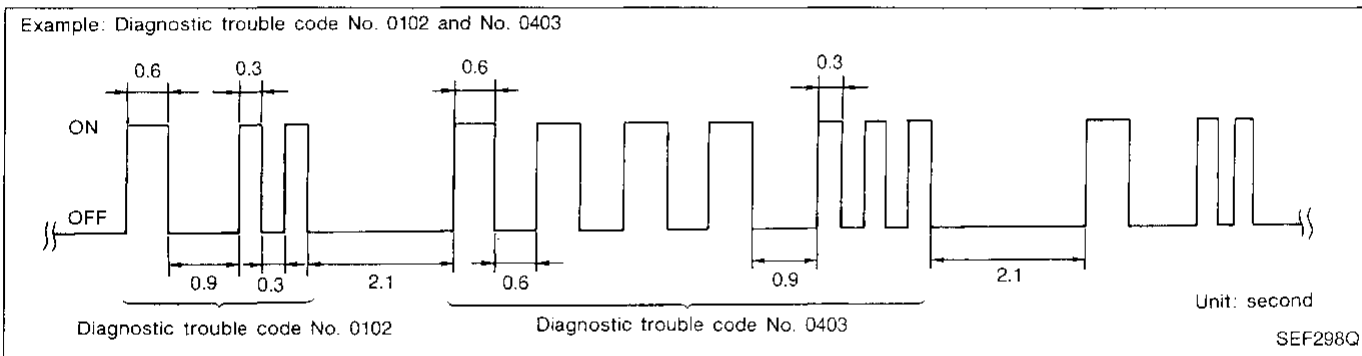

Long (0.6 second) blinking indicates the two LH digits of number and short (0.3 second) blinking indicates the two RH digits of number. For example, the malfunction indicator lamp blinks 10 times for 6 seconds (0.6 sec x 10 times) and then it blinks three times for about 1 second (0.3 sec x 3 times). This indicates the DTC "1003" and refers to the malfunction of the park/neutral position switch.

In this way, all the detected malfunctions are classified by their diagnostic trouble code numbers. The DTC "0505" refers to no malfunction. (See DIAGNOSTIC TROUBLE CODE (DTC) INDEX, EC-2.)

ON BOARD DIAGNOSTIC SYSTEM DESCRIPTION

CONSULT (Cont'd)

FUNCTION TEST MODE

FUNCTION TEST ITEM	CONDITION	JUDGEMENT		CHECK ITEM (REMEDY)
SELF-DIAG RESULTS	<ul style="list-style-type: none"> Ignition switch: ON (Engine stopped) Displays the results of on board diagnostic system. 	—		Objective system
CLOSED THROTTLE POSI	<ul style="list-style-type: none"> Ignition switch: ON (Engine stopped) Throttle position sensor circuit is tested when throttle is opened and closed fully. ("IDLE POSITION" is the test item name for the vehicles in which idle is selected by throttle position sensor.) 	Throttle valve: opened	OFF	<ul style="list-style-type: none"> Harness and connector Throttle position sensor (Closed throttle position) Throttle position sensor (Closed throttle position) adjustment Throttle linkage Verify operation in DATA MONITOR mode.
		Throttle valve: closed	ON	
THROTTLE POSI SEN CKT	<ul style="list-style-type: none"> Ignition switch: ON (Engine stopped) Throttle position sensor circuit is tested when throttle is opened and closed fully. 	Range (Throttle valve fully opened — Throttle valve fully closed)	More than 3.0V	<ul style="list-style-type: none"> Harness and connector Throttle position sensor Throttle position sensor adjustment Throttle linkage Verify operation in DATA MONITOR mode.
PARK/NEUT POSI SW CKT	<ul style="list-style-type: none"> Ignition switch: ON (Engine stopped) Inhibitor position switch circuit is tested when shift lever is manipulated. 	Out of N/P positions	OFF	<ul style="list-style-type: none"> Harness and connector Inhibitor switch Linkage or Inhibitor switch adjustment
		In N/P positions	ON	
FUEL PUMP CIRCUIT	<ul style="list-style-type: none"> Ignition switch: ON (Engine stopped) Fuel pump circuit is tested by checking the pulsation in fuel pressure when fuel tube is pinched. 	There is pressure pulsation on the fuel feed hose.		<ul style="list-style-type: none"> Harness and connector Fuel pump Fuel pump relay Fuel filter clogging Fuel level
EGRC SOL/V CIRCUIT	<ul style="list-style-type: none"> Ignition switch: ON (Engine stopped) EGR valve and EVAP canister purge control solenoid valve circuit is tested by checking solenoid valve operating noise. 	The solenoid valve makes an operating sound every 3 seconds.		<ul style="list-style-type: none"> Harness and connector EGR valve and EVAP canister purge control solenoid valve
START SIGNAL CIRCUIT	<ul style="list-style-type: none"> Ignition switch: ON → START Start signal circuit is tested when engine is started by operating the starter. Battery voltage and engine coolant temperature before cranking, and average battery voltage, mass air flow sensor output voltage and cranking speed during cranking are displayed. 	Start signal: OFF → ON		<ul style="list-style-type: none"> Harness and connector Ignition switch

Symptom Matrix Chart

SYSTEM — Basic engine control system		SYMPTOM												Reference page	
		HARD/NO START/RESTART (EXCP. HA)	ENGINE STALL	HESITATION/SURGING/FLAT SPOT	SPARK KNOCK/DETONATION	LACK OF POWER/POOR ACCELERATION	HIGH IDLE/LOW IDLE	ROUGH IDLE/HUNTING	IDLING VIBRATION	SLOW/NO RETURN TO IDLE	OVERHEATS/WATER TEMPERATURE HIGH	EXCESSIVE FUEL CONSUMPTION	EXCESSIVE OIL CONSUMPTION		BATTERY DEAD (UNDER CHARGE)
		AA	AB	AC	AD	AE	AF	AG	AH	AJ	AK	AL	AM		HA
Fuel	Fuel pump circuit	●	●	●	○	●	○	○	○		○		○	EC-328	
	Fuel pressure regulator system	●	○	●	○	○	○	○	○		○			EC-25	
	Injector circuit	●	●	●	○	●		●	○		○			EC-321	
	Evaporative emission system	○	○	○	○	○	○	○	○		○			EC-20	
Air	Positive crankcase ventilation system	○	●	○	○	○	○	●	○	○	○	○		EC-24	
	Incorrect idle speed adjustment	●	●				●	●	○	○	○			EC-29	
	IACV-AAC valve circuit	○	●	○	○	○	●	●	○	○	○		○	EC-252	
	IACV-FICD solenoid valve circuit	○	○	○	○	○	○	○	○	○	○			EC-337	
Ignition	Incorrect ignition timing adjustment	●	●	●	●	●		●	○			●		EC-29	
	Ignition circuit	●	●	●	●	●		●	○			●		EC-279	
EGR	EGR valve & EVAP canister purge control solenoid valve circuit		○	●	○	○						○		EC-290	
	EGR system	○	●	●	●	●	○	●	○	○		○		EC-209	
Main power supply and ground circuit		●	○	○	○	○		○	○		○	○		EC-94	
Air conditioner circuit		○	○	○	○	○	○	○	○		○		○	HA section	

● ; High Possibility Item
○ ; Low Possibility Item

(continued on next page)

TROUBLE DIAGNOSIS — General Description

ECM Terminals and Reference Value (Cont'd)

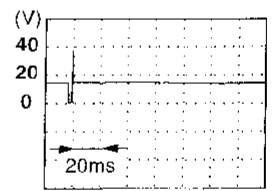
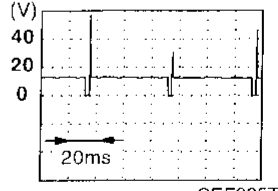
TER-MINAL NO.	WIRE COLOR	ITEM	CONDITION	DATA (DC Voltage)
59	Y/B	MAP/BARO switch solenoid valve	Ignition switch "ON" └ Engine is not running	BATTERY VOLTAGE (11 - 14V)
62	P/G	EGR temperature sensor	Engine is running. (Warm-up condition) └ Idle speed	Less than 4.5V
			Engine is running. (Warm-up condition) └ EGR system is operating	0 - 1.5V
63	Y	Tank fuel temperature sensor	Engine is running.	Approximately 0 - 4.8V Output voltage varies with fuel temperature.
64	W	Data link connector for CONSULT	Engine is running.	Approximately 0V
65	L		└ Idle speed (CONSULT is connected and turned on)	Approximately 4 - 9V
68	OR			Approximately 3.5V*
66	W	Rear heated oxygen sensor (LH)	Engine is running. └ After warming up sufficiently and engine speed is 2,000 rpm	0 - Approximately 1.0V
67	G	EVAP control system pressure sensor	Ignition switch "ON"	Approximately 3.4V
70	W/R	Power supply (Back-up)	Ignition switch "OFF"	BATTERY VOLTAGE (11 - 14V)
102	W	Injector No. 1		BATTERY VOLTAGE (11 - 14V)
104	Y/R	Injector No. 3	Engine is running. (Warm-up condition) └ Idle speed	 <p style="text-align: right;">SEF204T</p>
107	Y	Injector No. 2		
109	W/L	Injector No. 4		
111	W/G	Injector No. 5	Engine is running. (Warm-up condition) └ Engine speed is 2,000 rpm	 <p style="text-align: right;">SEF205T</p>
114	W/B	Injector No. 6		
101	PU/R	Rear heated oxygen sensor heater (LH)	Engine is running. └ Engine speed is below 3,200 rpm	Approximately 0.4V
			Engine is running. └ Engine speed is above 3,200 rpm	BATTERY VOLTAGE (11 - 14V)

TROUBLE DIAGNOSIS FOR DTC P0105

Absolute Pressure Sensor (Cont'd)

If the DTC cannot be confirmed, perform "Procedure for malfunction B", "OVERALL FUNCTION CHECK".

Procedure for malfunction C

- 1) Start engine and warm it up sufficiently.
- 2) Turn ignition switch "OFF" and wait at least 5 seconds.
- 3) Turn ignition switch "ON" and select "DATA MONITOR" mode with CONSULT.
- 4) Start engine and let it idle.
- 5) Wait at least 15 seconds.

OR

- 1) Start engine and warm it up sufficiently.
- 2) Turn ignition switch "OFF" and wait at least 5 seconds.
- 3) Start engine.
- 4) Let engine idle and wait at least 15 seconds.
- 5) Select "MODE 7" with GST.

OR

- 1) Start engine and warm it up sufficiently.
- 2) Turn ignition switch "OFF" and wait at least 5 seconds.
- 3) Start engine.
- 4) Let engine idle and wait at least 15 seconds.
- 5) Turn ignition switch "OFF".
- 6) Perform "Diagnostic Test Mode II (Self-diagnostic results)" with ECM.

OVERALL FUNCTION CHECK

Use this procedure to check the overall function of absolute pressure sensor circuit. During this check, a 1st trip DTC might not be confirmed.

Procedure for malfunction B

- 1) Turn ignition switch "ON".
- 2) Select "ABSOL PRES/SE" in "DATA MONITOR" mode with CONSULT.
- 3) Make sure that the voltage of "ABSOL PRES/SE" is more than 1.74 [V].

OR

- 1) Turn ignition switch "ON".
- 2) Select "MAP" in "MODE 1" with GST.
- 3) Make sure that the pressure of "MAP" is more than 46 kPa (0.47 kg/cm², 6.7 psi).

OR

- 1) Turn ignition switch "ON".
- 2) Make sure that the voltage between ECM terminal ④5 and ground is more than 1.74 [V].

If the DTC cannot be confirmed, perform "Procedure for malfunction C" on the previous page.

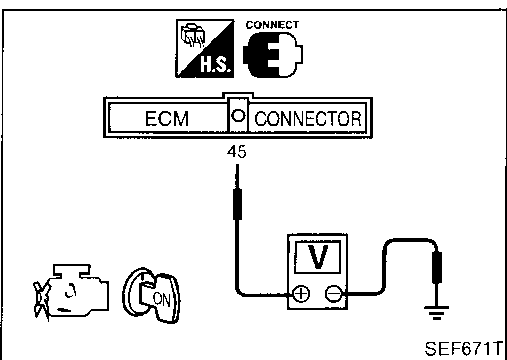
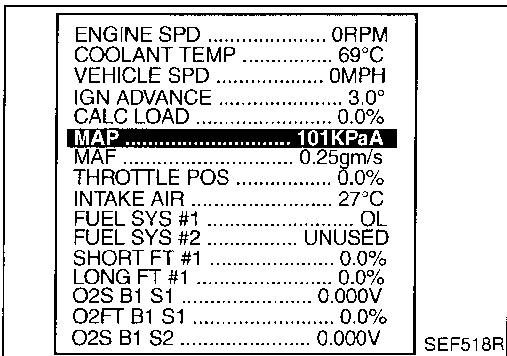
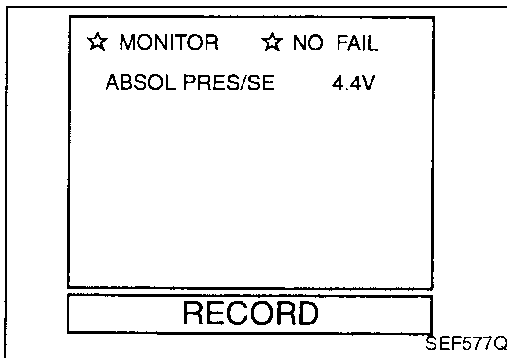

TROUBLE DIAGNOSIS FOR DTC P0115

Engine Coolant Temperature Sensor (ECTS) (Cont'd)

COMPONENT INSPECTION

Engine coolant temperature sensor

Check resistance as shown in the figure.

⟨Reference data⟩

Temperature °C (°F)	Resistance kΩ
20 (68)	2.1 - 2.9
50 (122)	0.68 - 1.00
90 (194)	0.236 - 0.260

If NG, replace engine coolant temperature sensor.

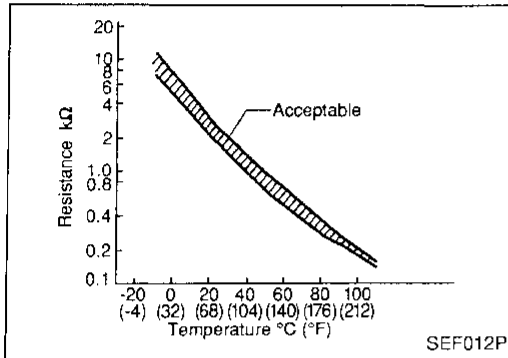
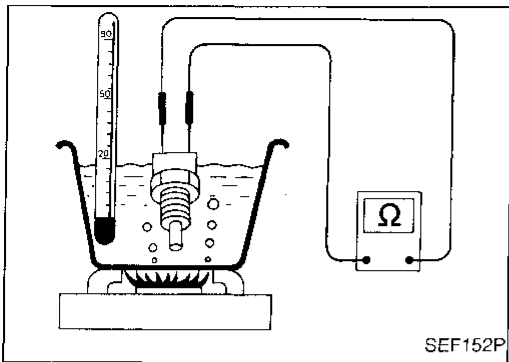

TROUBLE DIAGNOSIS FOR DTC P0130

Front Heated Oxygen Sensor (Front HO2S) (Right bank) (Cont'd)

OVERALL FUNCTION CHECK

Use this procedure to check the overall function of the front heated oxygen sensor circuit. During this check, a 1st trip DTC might not be confirmed.

- 1) Start engine and warm it up sufficiently.
 - 2) Select "MANU TRIG" and "HI SPEED" in "DATA MONITOR" mode with CONSULT, and select "FR O2 SEN-B1" and "FR O2 MNTR-B1".
 - 3) Hold engine speed at 2,000 rpm under no load during the following steps.
 - 4) Touch "RECORD" on CONSULT screen.
 - 5) Check the following.
 - "FR O2 MNTR-B1" in "DATA MONITOR" mode changes from "RICH" to "LEAN" to "RICH" 5 times in 10 seconds.
- 5 times (cycles) are counted as shown below:

cycle | 1 | 2 | 3 | 4 | 5 |
FR O2 MNTR-B1 R-L-R-L-R-L-R-L-R-L-R

R = "FR O2 MNTR-B1", "RICH"
L = "FR O2 MNTR-B1", "LEAN"

- "FR O2 SEN-B1" voltage goes above 0.6V at least once.
- "FR O2 SEN-B1" voltage goes below 0.35V at least once.
- The voltage never exceeds 1.0V.

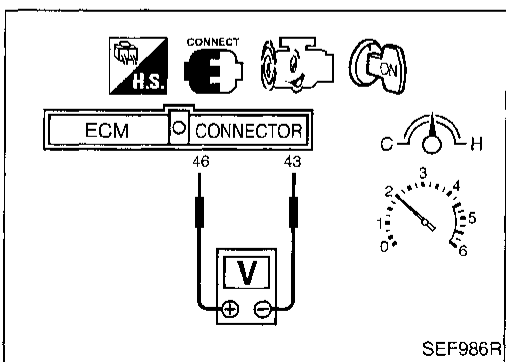
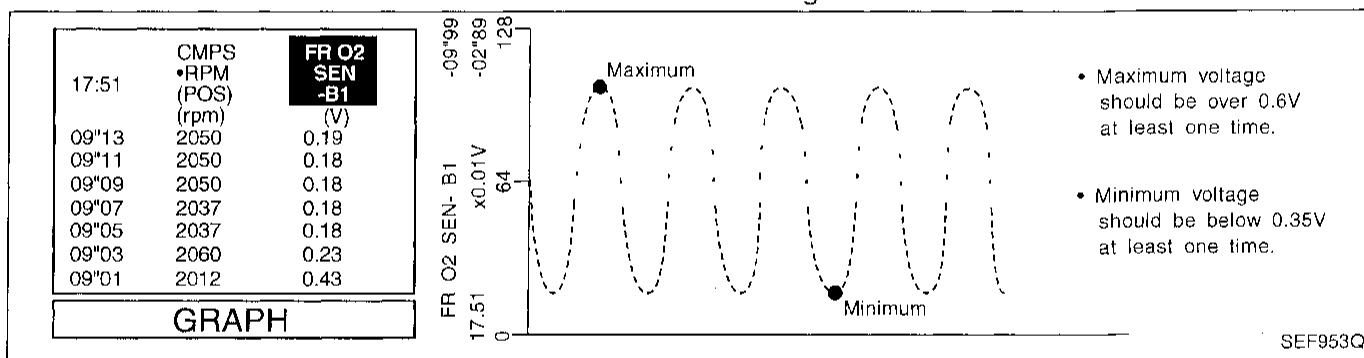
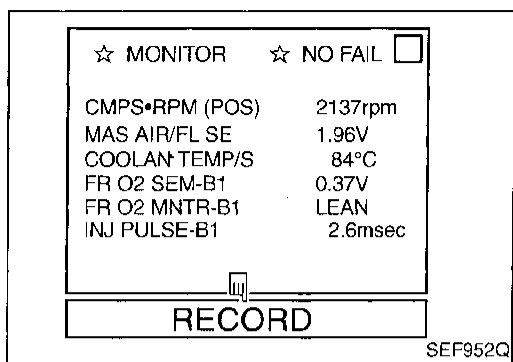

OR

- 1) Start engine and warm it up sufficiently.
- 2) Set voltmeter probes between ECM terminal ④⑥ (sensor signal) and ④③ (engine ground).
- 3) Check the following with engine speed held at 2,000 rpm constant under no load.
 - Malfunction indicator lamp goes on more than 5 times within 10 seconds in Diagnostic Test Mode II (FRONT HEATED OXYGEN SENSOR MONITOR).
 - The maximum voltage is over 0.6V at least one time.
 - The minimum voltage is below 0.35V at least one time.
 - The voltage never exceeds 1.0V.

TROUBLE DIAGNOSIS FOR DTC P0141

Rear Heated Oxygen Sensor Heater (Right bank) (Cont'd)

EC-RO2H-R-01

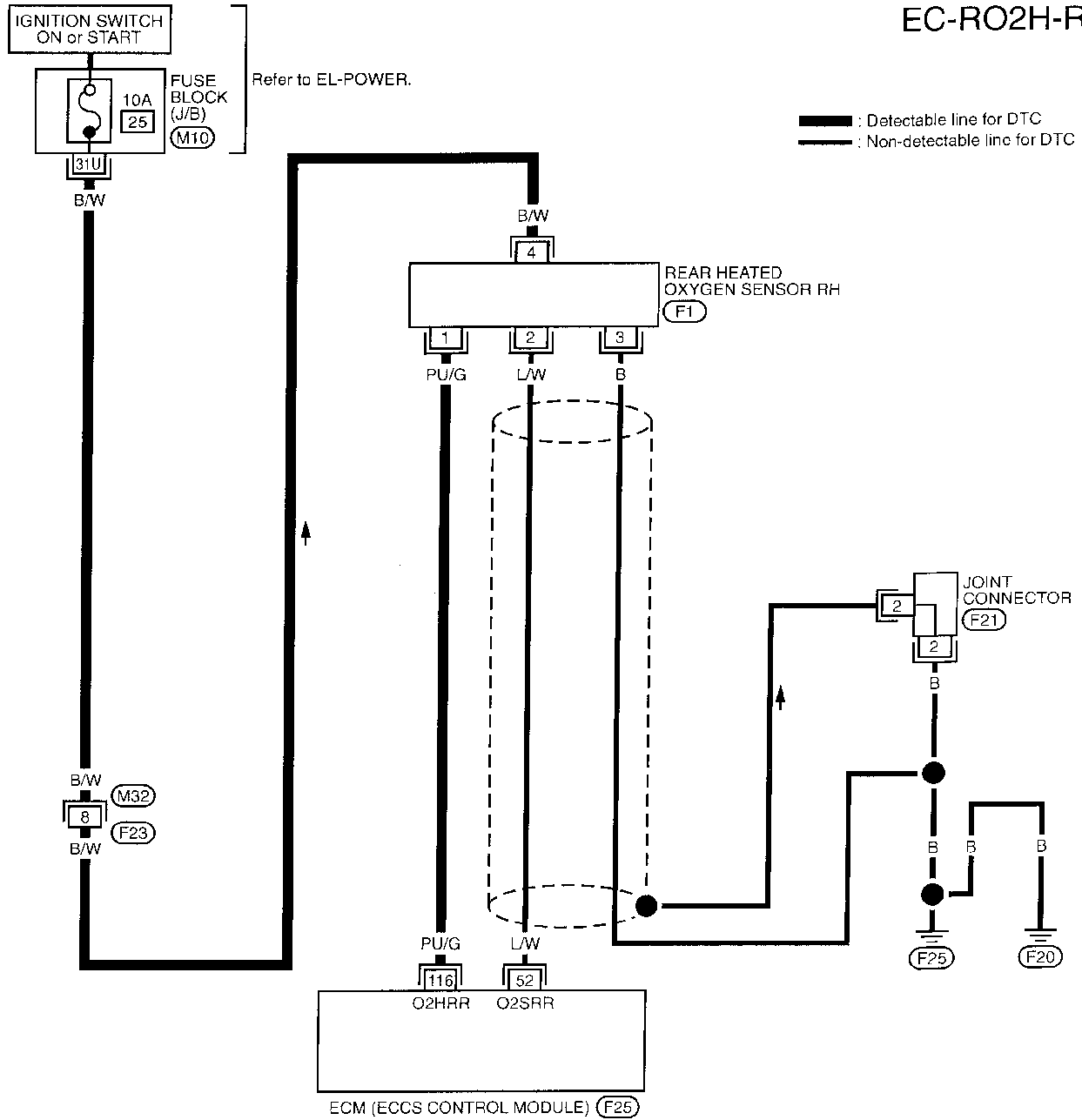

Refer to last page (Foldout page).

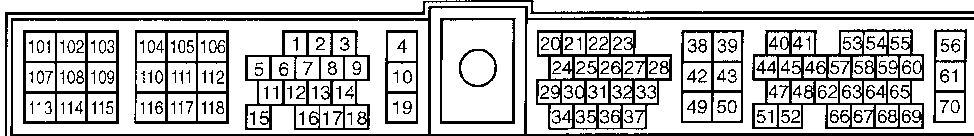
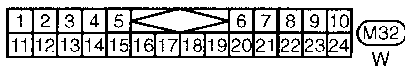
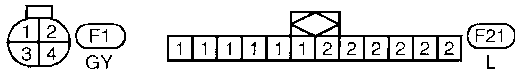

TROUBLE DIAGNOSIS FOR DTC P0156

Rear Heated Oxygen Sensor (Rear HO2S) (Left bank) (Cont'd)

EC-RRO2LH-01

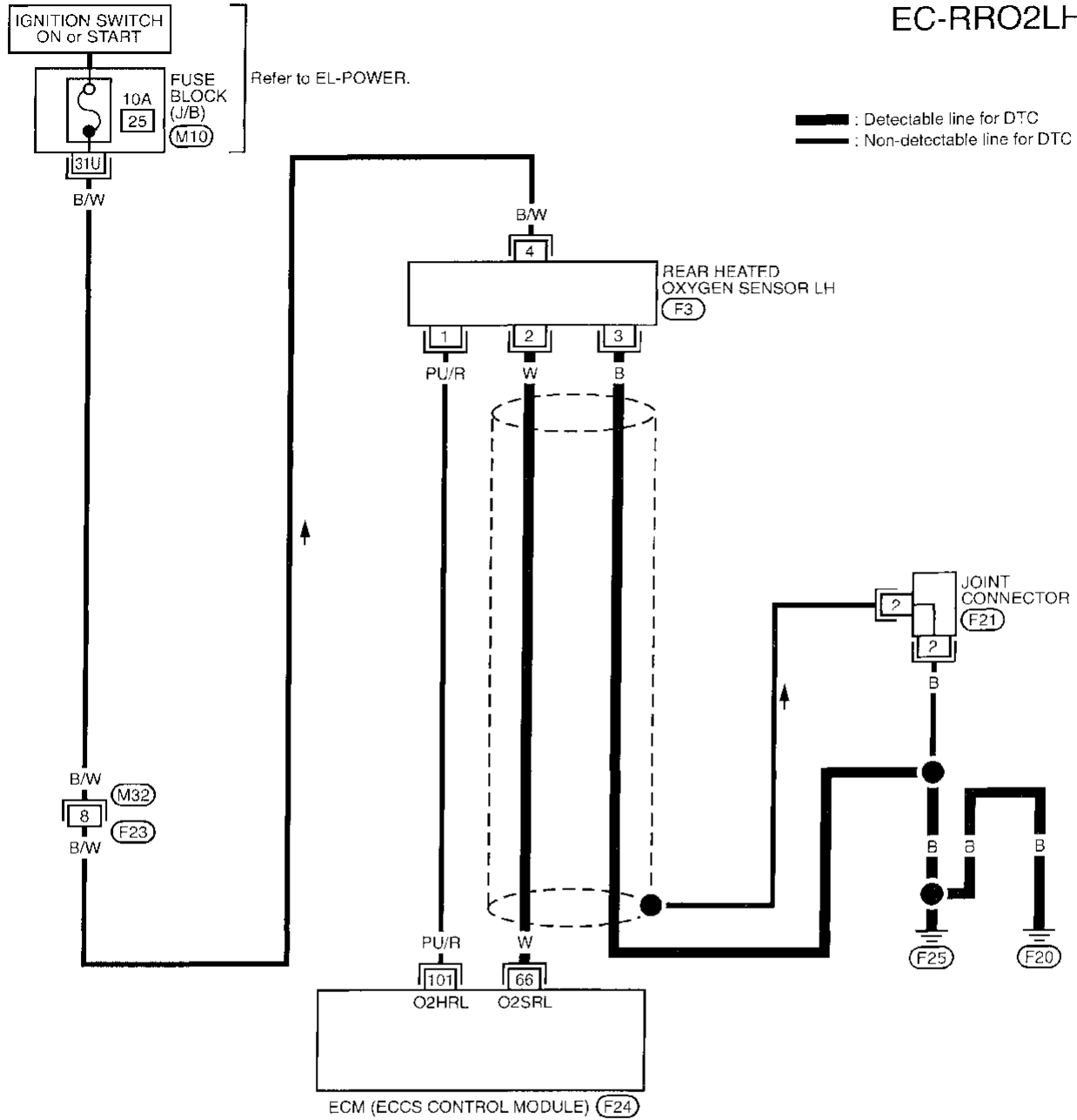

Refer to last page (Foldout page).

(M10)

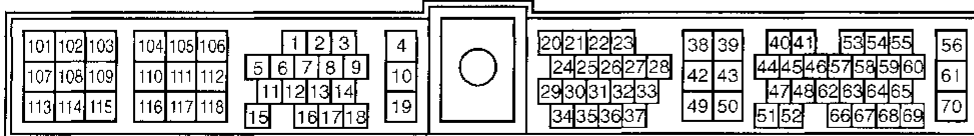
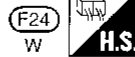
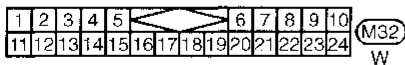
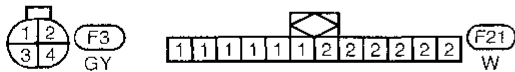

TROUBLE DIAGNOSIS FOR DTC P0172

Fuel Injection System Function (Right bank) (Rich side) (Cont'd)

DIAGNOSTIC PROCEDURE

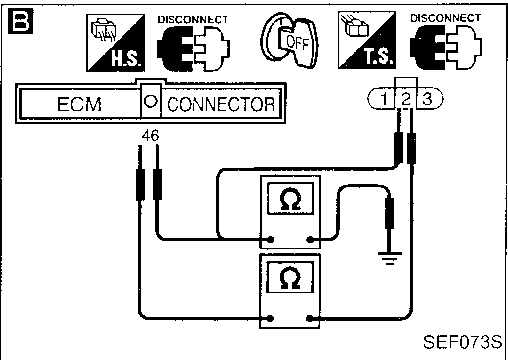
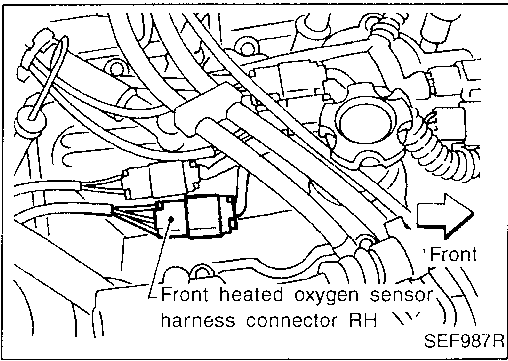
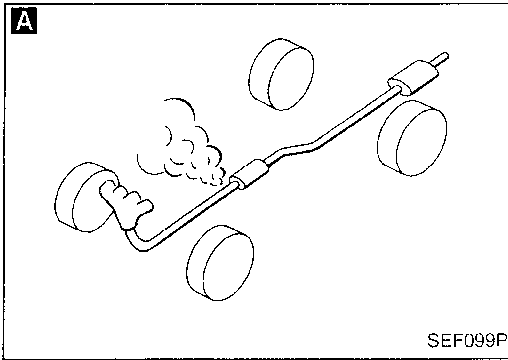

INSPECTION START

A
CHECK FOR EXHAUST AIR LEAK.
Start engine and run it at idle. Listen for an exhaust air leak before the three way catalyst.

NG → Repair or replace.

OK ↓

B
CHECK FRONT HEATED OXYGEN SENSOR (RIGHT BANK).
1. Turn ignition switch "OFF".
2. Disconnect front heated oxygen sensor RH harness connector and ECM harness connector.
3. Check harness continuity between ECM terminal ④ and terminal ② .
Continuity should exist.
4. Check harness continuity between ECM terminal ④ (or terminal ②) and ground.
Continuity should not exist.
If OK, check harness for short.

NG → Repair harness or connectors.

OK ↓

CHECK FUEL PRESSURE.
1. Release fuel pressure to zero. Refer to EC-25.
2. Install fuel pressure gauge and check fuel pressure.
At idling:
When fuel pressure regulator valve vacuum hose is connected.
Approximately 250.1 kPa (2.55 kg/cm², 36.3 psi)
When fuel pressure regulator valve vacuum hose is disconnected.
Approximately 299.1 kPa (3.05 kg/cm², 43.4 psi)

NG → Check fuel pump and circuit. Refer to EC-328.

OK ↓

CHECK MASS AIR FLOW SENSOR.
Check "MASS AIR FLOW" in "DATA MONITOR" mode with CONSULT.
3.3 - 4.8 g-m/sec: at idling
12.0 - 14.9 g-m/sec: at 2,500 rpm
OR
Check "mass air flow" in MODE 1 with GST.
3.3 - 4.8 g-m/sec: at idling
12.0 - 14.9 g-m/sec: at 2,500 rpm

NG → Check connectors for rusted terminals or loose connections in the mass air flow sensor circuit or engine grounds. Refer to EC-99.

OK ↓

Ⓐ

TROUBLE DIAGNOSIS FOR DTC P0180

Tank Fuel Temperature Sensor (Cont'd)

DIAGNOSTIC PROCEDURE

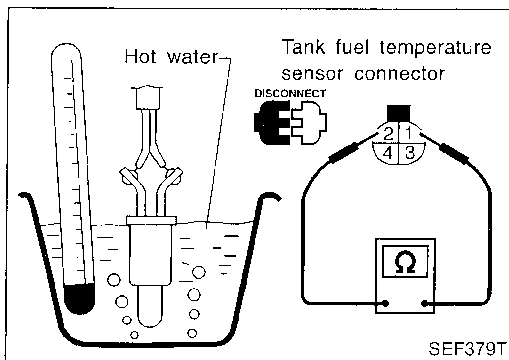
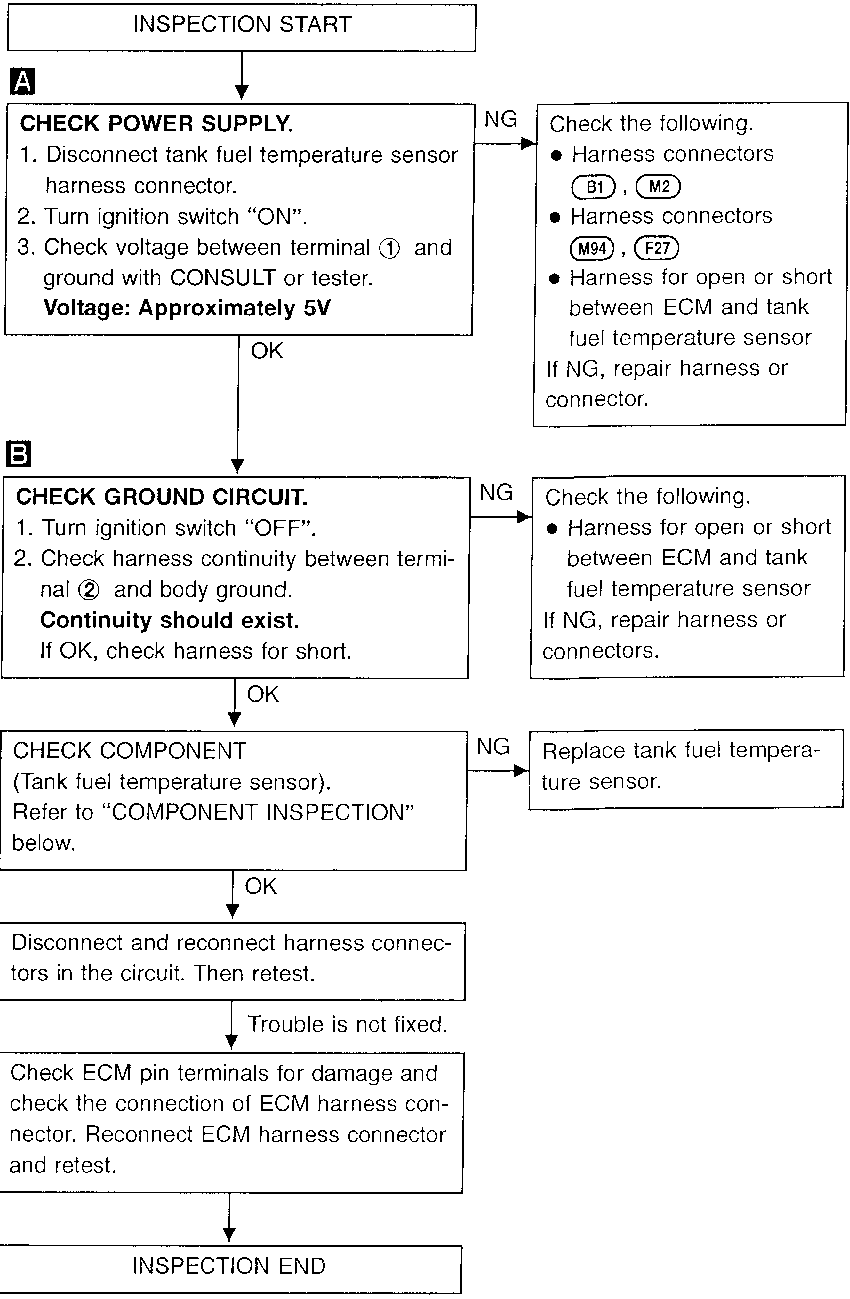
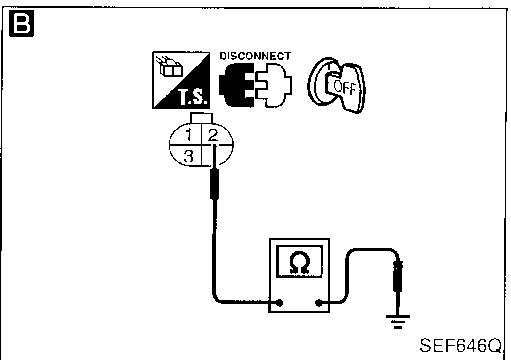
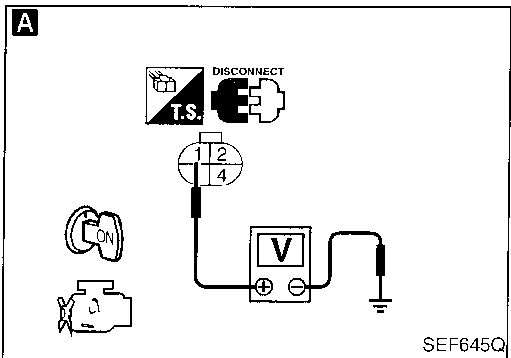
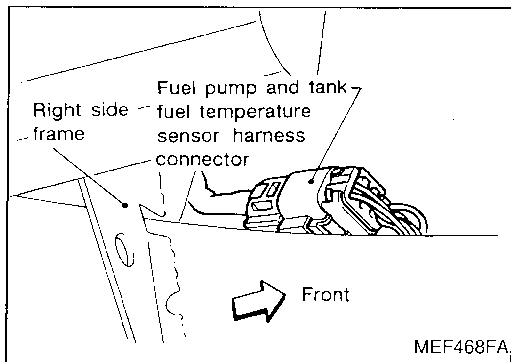

COMPONENT INSPECTION

Tank fuel temperature sensor

Check resistance by heating with hot water or heat gun as shown in the figure.

Temperature °C (°F)	Resistance kΩ
20 (68)	2.3 - 2.7
50 (122)	0.79 - 0.90

If NG, replace tank fuel temperature sensor.

TROUBLE DIAGNOSIS FOR DTC P0340

Camshaft Position Sensor (CMPS) (Cont'd)

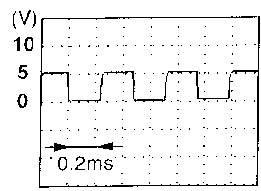
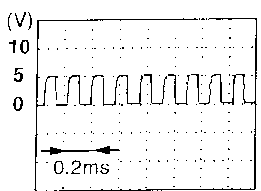
TER-MINAL NO.	WIRE COLOR	ITEM	CONDITION	DATA (DC Voltage)
41	B/W	Camshaft position sensor (Position signal)	<div style="border: 1px solid black; padding: 2px; display: inline-block;">Engine is running.</div> (Warm-up condition) ↳ Idle speed	Approximately 2.5V 
			<div style="border: 1px solid black; padding: 2px; display: inline-block;">Engine is running.</div> ↳ Engine speed is 2,000 rpm.	Approximately 2.5V 
56	B/W	Power supply for ECM	<div style="border: 1px solid black; padding: 2px; display: inline-block;">Ignition switch "ON"</div>	BATTERY VOLTAGE (11 - 14V)
61	B/W		<div style="border: 1px solid black; padding: 2px; display: inline-block;">Engine is running.</div> ↳ Idle speed	BATTERY VOLTAGE (11 - 14V)

ON BOARD DIAGNOSIS LOGIC

Diagnostic Trouble Code No.	Malfunction is detected when	Check Items (Possible Cause)
P0340 0101	A) Either 1° or 120° signal is not sent to ECM for the first few seconds during engine cranking. B) Either 1° or 120° signal is not sent to ECM often enough while the engine speed is higher than the specified engine speed. C) The relation between 1° and 120° signal is not in the normal range during the specified engine speed.	<ul style="list-style-type: none"> ● Harness or connectors (The camshaft position sensor circuit is open or shorted.) ● Camshaft position sensor ● Starter motor (Refer to EL section.) ● Starting system circuit (Refer to EL section.) ● Dead (Weak) battery

TROUBLE DIAGNOSIS FOR DTC P0402

EGRC-BPT Valve Function (Cont'd)

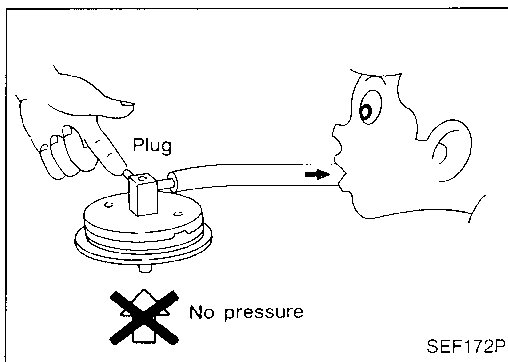
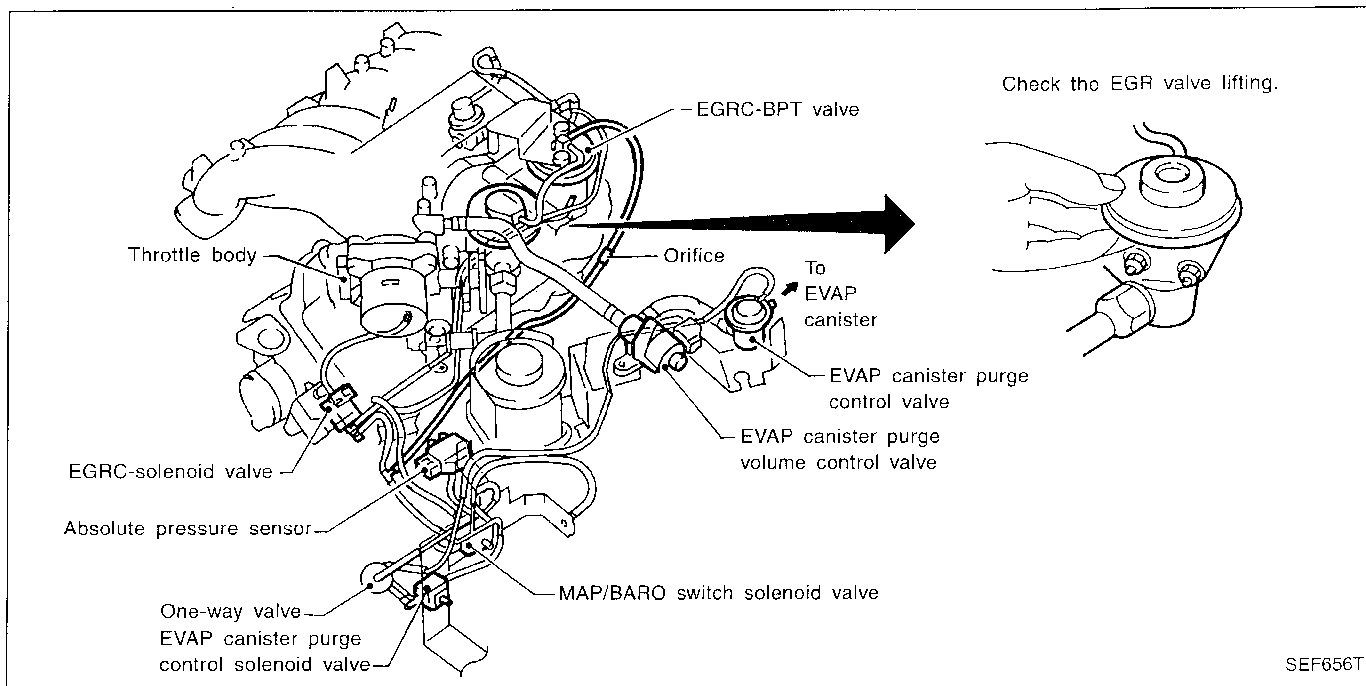

COMPONENT INSPECTION

EGRC-BPT valve

1. Plug one of two ports of EGRC-BPT valve.
2. Vacuum from the other port and check leakage without applying any pressure from under EGR-BPT valve.
Leakage should exist.

TROUBLE DIAGNOSIS FOR DTC P0443

Evaporative Emission (EVAP) Canister Purge Control Valve/Solenoid Valve (Cont'd)

DIAGNOSTIC TROUBLE CODE CONFIRMATION PROCEDURE

Perform "Procedure for malfunction A" first. If the (1st trip) DTC cannot be confirmed, perform "Procedure for malfunction B".

Procedure for malfunction A

- 1) Turn ignition switch "ON".
 - 2) Select "DATA MONITOR" mode with CONSULT.
 - 3) Wait at least 5 seconds.
- OR
- 1) Turn ignition switch "ON" and wait at least 5 seconds.
 - 2) Select "MODE 7" with GST.
- OR
- 1) Turn ignition switch "ON" and wait at least 5 seconds.
 - 2) Perform "Diagnostic Test Mode II (Self-diagnostic results)" with ECM.

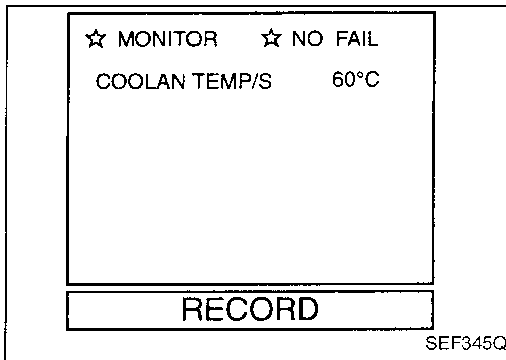

Procedure for malfunction B

- 1) Jack up drive wheels.
- 2) Turn ignition switch "ON" and select "DATA MONITOR" mode with CONSULT.
- 3) Start engine and warm it up until the engine coolant temperature is higher than or equal to 75°C (167°F), then stop engine.
- 4) Start engine and let it idle for at least 70 seconds.
- 5) Maintain the following conditions for at least 30 seconds.

Gear position:

"2" or "D" range (A/T)

"3rd" or "4th" gear (M/T)

Vehicle speed:

40 - 80 km/h (25 - 50 MPH)

Engine speed:

1,050 - 3,000 rpm

Engine coolant temperature:

Less than 100°C (212°F)

TROUBLE DIAGNOSIS FOR DTC P0450

Evaporative Emission (EVAP) Control System Pressure Sensor (Cont'd)

DIAGNOSTIC PROCEDURE

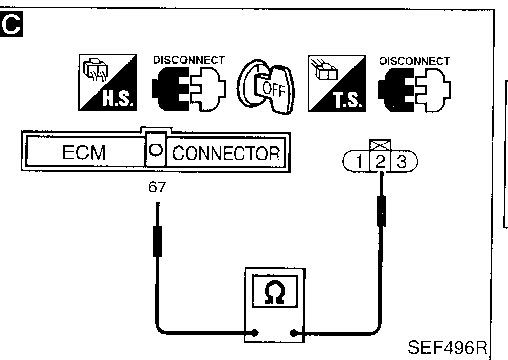
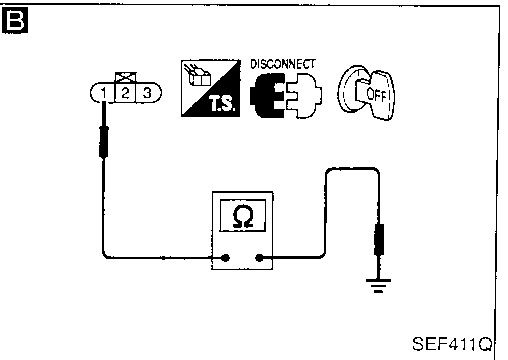
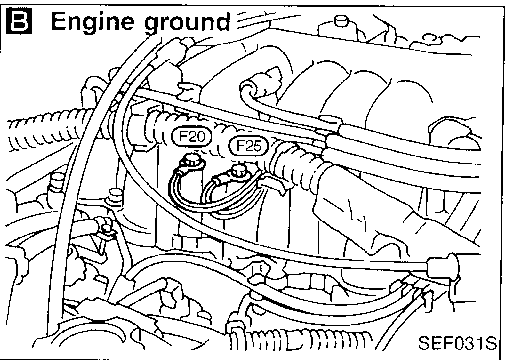
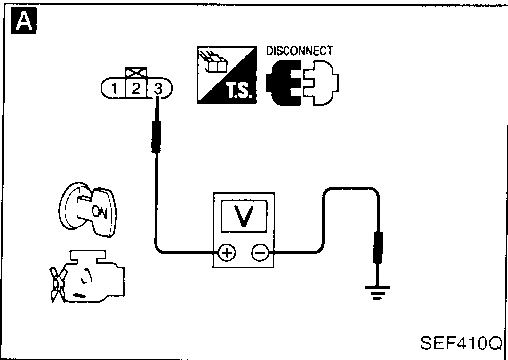
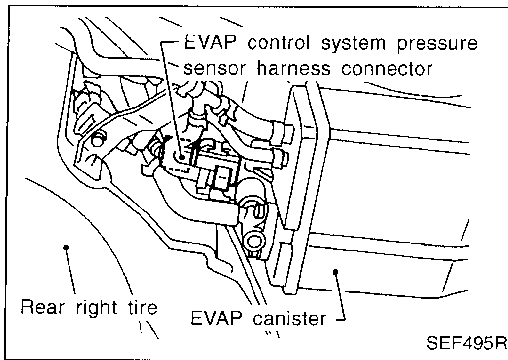

INSPECTION START

A
CHECK POWER SUPPLY.
1. Turn ignition switch "OFF".
2. Disconnect EVAP control system pressure sensor harness connector.
3. Turn ignition switch "ON".
4. Check voltage between terminal ③ and engine ground with CONSULT or tester.
Voltage: Approximately 5V

NG → Check the following.

- Harness connectors (B101), (B43)
- Harness connectors (B1), (M2)
- Harness connectors (M94), (F27)
- Harness for open or short between EVAP control system pressure sensor and ECM

If NG, repair harness or connectors.

B
CHECK GROUND CIRCUIT.
1. Turn ignition switch "OFF".
2. Loosen and retighten ground screw.
3. Check harness continuity between terminal ① and engine ground.
Continuity should exist.
If OK, check harness for short.

NG → Check the following.

- Harness connectors (B101), (B43)
- Harness connectors (B1), (M2)
- Harness connectors (M94), (F27)
- Harness for open or short between ECM and EVAP control system pressure sensor

If NG, repair harness or connectors.

C
CHECK INPUT SIGNAL CIRCUIT.
1. Disconnect ECM harness connector.
2. Check harness continuity between ECM terminal ⑥7 and terminal ②.
Continuity should exist.
If OK, check harness for short.

NG → Check the following.

- Harness connectors (B101), (B43)
- Harness connectors (B1), (M2)
- Harness connectors (M94), (F27)
- Harness for open or short between ECM and EVAP control system pressure sensor

If NG, repair harness or connectors.

CHECK COMPONENT
(EVAP canister vent control valve).
Refer to "COMPONENT INSPECTION", EC-242.

OK → (A)

TROUBLE DIAGNOSIS FOR DTC P0510

Closed Throttle Position Switch (Cont'd) COMPONENT INSPECTION

Closed throttle position switch

1. Start engine and warm it up sufficiently.
2. Turn ignition switch "OFF".
3. Disconnect throttle position switch harness connector.
4. Check continuity between terminals ⑤ and ⑥ while opening throttle valve manually.

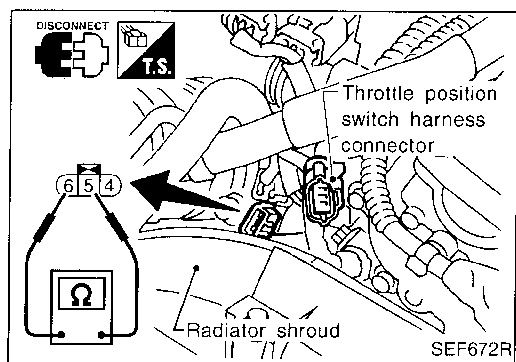

Throttle valve conditions	Continuity
Completely closed	Yes
Partially open or completely open	No

If NG, replace throttle position switch.

TROUBLE DIAGNOSIS FOR DTC P1105

Manifold Absolute Pressure (MAP)/Barometric Pressure (BARO) Switch Solenoid Valve (Cont'd)

ECM TERMINALS AND REFERENCE VALUE

Specification data are reference values and are measured between each terminal and Ⓒ (ECCS ground).

TER-MINAL NO.	WIRE COLOR	ITEM	CONDITION	DATA (DC Voltage)
59	Y/B	MAP/BARO switch solenoid valve	<div style="border: 1px solid black; padding: 2px; display: inline-block;">Ignition switch "ON"</div> Engine is not running.	BATTERY VOLTAGE (11 - 14V)

ON BOARD DIAGNOSIS LOGIC

Diagnostic Trouble Code No.	Malfunction is detected when ...	Check Items (Possible Cause)
P1105 1302	<ul style="list-style-type: none"> • MAP/BARO switch solenoid valve receives the voltage supplied though ECM does not supply the voltage to the valve. • There is little difference between MAP/BARO switch solenoid valve input voltage at ambient barometric pressure and voltage at intake manifold pressure. 	<ul style="list-style-type: none"> • Harness or connectors (MAP/BARO switch solenoid valve circuit is open or shorted.) • Hoses (Hoses are clogged or disconnected.) • Absolute pressure sensor • MAP/BARO switch solenoid valve

DIAGNOSTIC TROUBLE CODE CONFIRMATION PROCEDURE



- 1) Start engine and warm it up sufficiently.
- 2) Turn ignition switch "OFF" and wait at least 5 seconds.
- 3) Turn ignition switch "ON" and select "DATA MONITOR" mode with CONSULT.
- 4) Start engine and let it idle.
- 5) Wait at least 20 seconds.

OR



- 1) Start engine and warm it up sufficiently.
- 2) Turn ignition switch "OFF" and wait at least 5 seconds.
- 3) Start engine and let it idle.
- 4) Wait at least 20 seconds.
- 5) Select "MODE 7" with GST.

OR



- 1) Start engine and warm it up sufficiently.
- 2) Turn ignition switch "OFF" and wait at least 5 seconds.
- 3) Start engine and let it idle.
- 4) Wait at least 20 seconds.
- 5) Turn ignition switch "OFF", wait at least 5 seconds and then turn "ON".
- 6) Perform "Diagnostic Test Mode II (Self-diagnostic results)" with ECM.

TROUBLE DIAGNOSIS FOR DTC P1336

Crankshaft Position Sensor (CKPS) (OBD) (COG) (Cont'd)

DIAGNOSTIC PROCEDURE

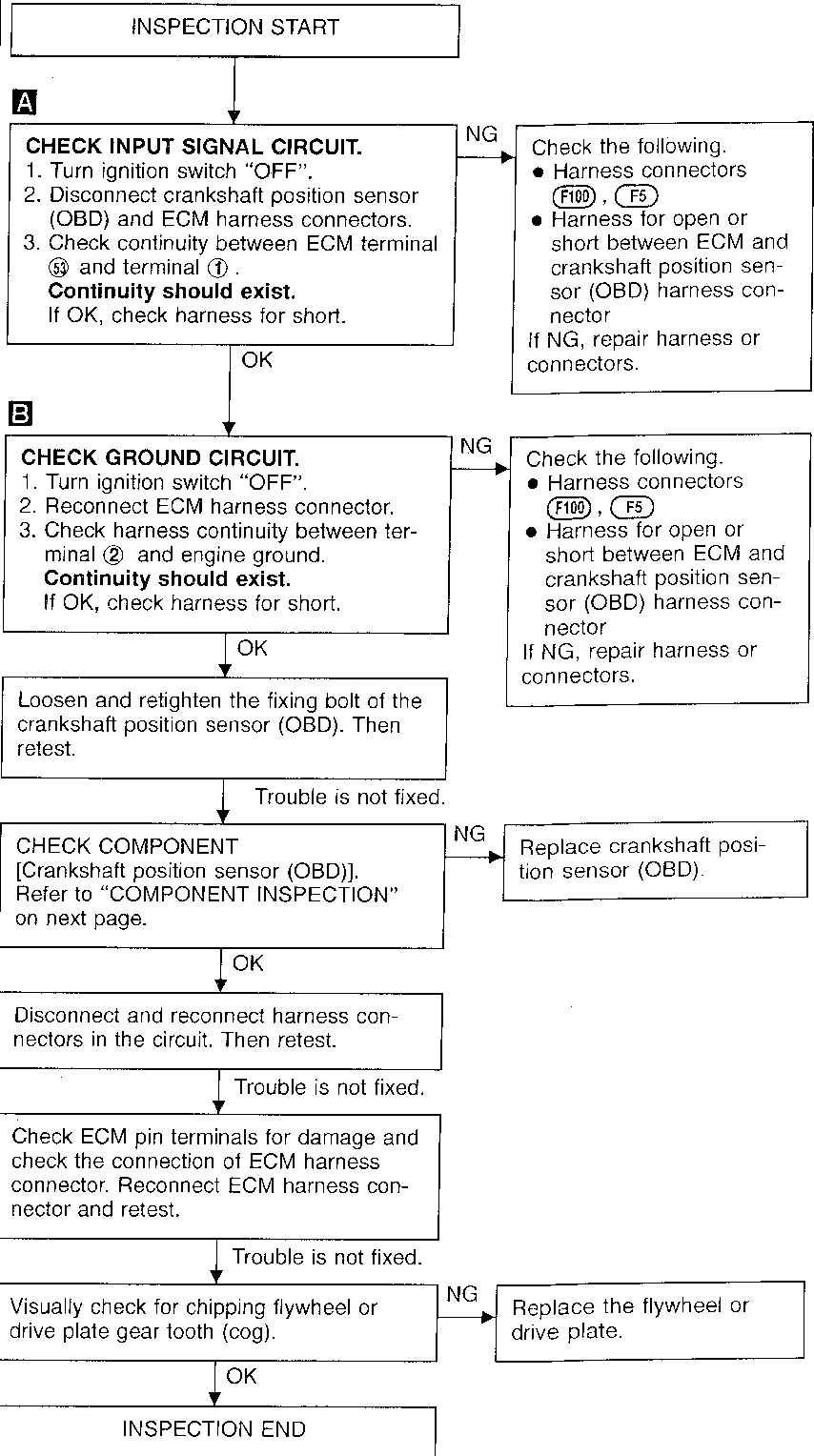
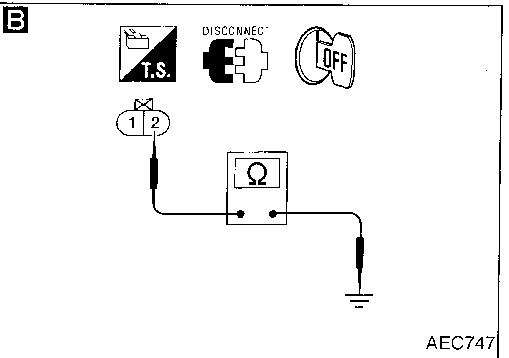
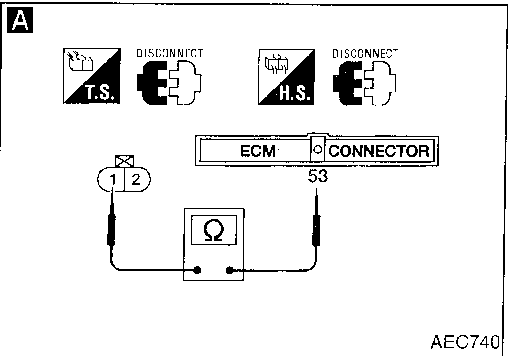
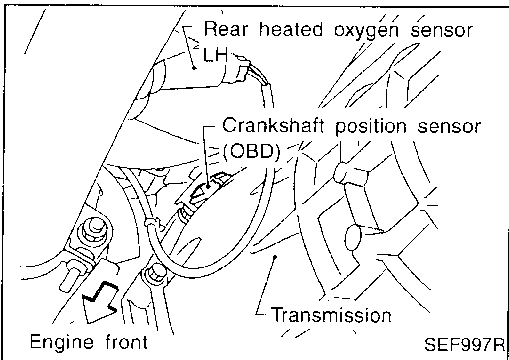

TROUBLE DIAGNOSIS FOR DTC P1441

Vacuum Cut Valve Bypass Valve (Cont'd)

DIAGNOSTIC PROCEDURE

Procedure for malfunction A

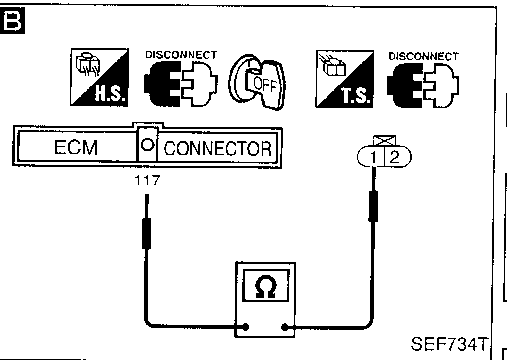
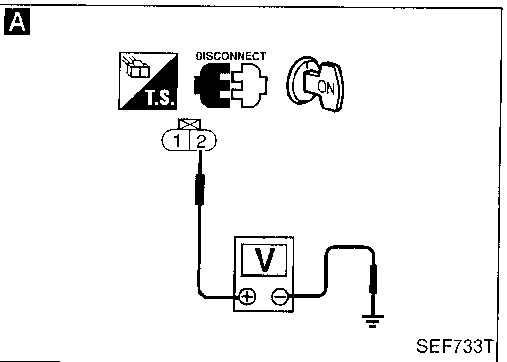
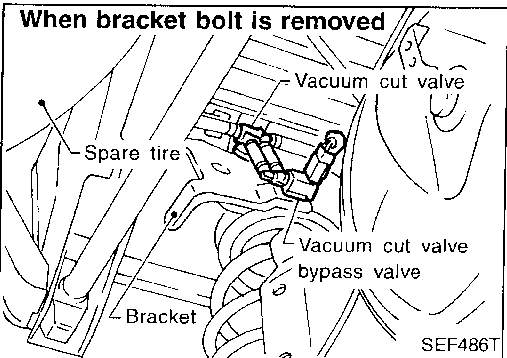
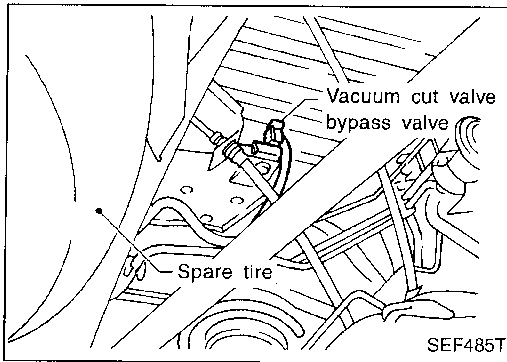

INSPECTION START

A

CHECK POWER SUPPLY.

1. Turn ignition switch "OFF".
2. Disconnect vacuum cut valve bypass valve harness connector.
3. Turn ignition switch "ON".
4. Check voltage between terminal ② and ground with CONSULT or tester.

Voltage: Battery voltage

NG

Check the following.

- Harness connectors (M2), (B1)
- Harness connectors (B43), (B101)
- 10A fuse
- Harness for open or short between vacuum cut valve bypass valve and fuse

If NG, repair harness or connectors.

OK

B

CHECK OUTPUT SIGNAL CIRCUIT.

1. Turn ignition switch "OFF".
2. Disconnect ECM harness connector.
3. Check harness continuity between ECM terminal (117) and terminal ①.

Continuity should exist.
If OK, check harness for short.

NG

Check the following.

- Harness connectors (B101), (B43)
- Harness connectors (B1), (M2)
- Harness connectors (M94), (F27)
- Harness for open or short between vacuum cut valve bypass valve and ECM

If NG, repair harness or connectors.

OK

CHECK COMPONENT
(Vacuum cut valve bypass valve).
Refer to "COMPONENT INSPECTION" on next page.

NG

Replace vacuum cut valve bypass valve.

OK

Disconnect and reconnect harness connectors in the circuit. Then retest.

Trouble is not fixed.

Check ECM pin terminals for damage and check the connection of ECM harness connector. Reconnect ECM harness connector and retest.

INSPECTION END

TROUBLE DIAGNOSIS FOR DTC P1447

Evaporative Emission (EVAP) Control System Purge Flow Monitoring (Cont'd)

EVAP canister purge control valve

Check EVAP canister purge control valve as follows:

1. Plug the port (B).
2. Apply pressure [80.0 kPa (600 mmHg, 23.62 inHg, 11.60 psi)] to port (A). Then keep it for 15 seconds, and check there is no leakage.
3. Repeat step 2 for port (C).

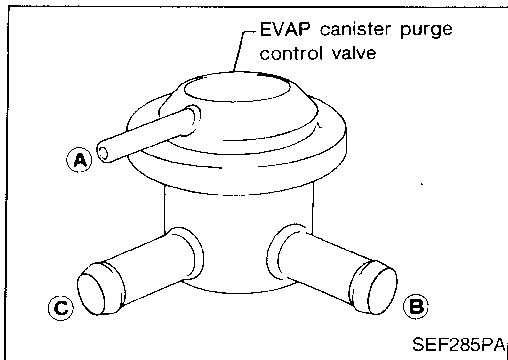

EVAP canister purge control solenoid valve

Check air passage continuity.

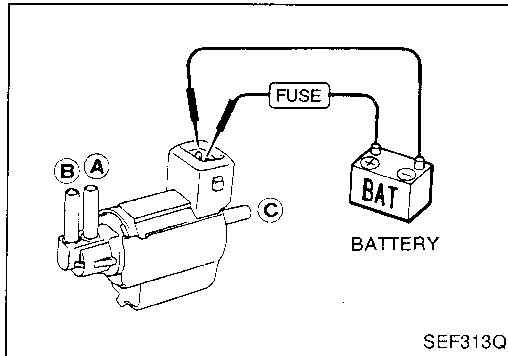

Condition	Air passage continuity between (A) and (B)	Air passage continuity between (A) and (C)
12V direct current supply between terminals	Yes	No
No supply	No	Yes

If NG, replace solenoid valve.

EVAP control system pressure sensor

1. Remove EVAP control system pressure sensor with its harness connector connected.
2. Remove hose from EVAP control system pressure sensor.
3. Use pump to apply vacuum and pressure to EVAP control system pressure sensor as shown in figure.
4. Check output voltage between terminal (2) and engine ground.

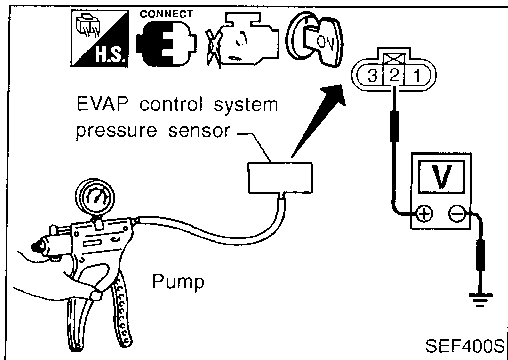

Pressure (Relative to atmospheric pressure)	Voltage (V)
0 kPa (0 mmHg, 0 inHg, 0 psi)	3.0 - 3.6
-9.3 kPa (-70 mmHg, -2.76 inHg, -1.35 psi)	0.4 - 0.6

CAUTION:

Always calibrate the vacuum pump gauge when using it.

5. If NG, replace EVAP control system pressure sensor.

TROUBLE DIAGNOSIS FOR NON-DETECTABLE ITEMS

Fuel Pump (Cont'd) DIAGNOSTIC PROCEDURE

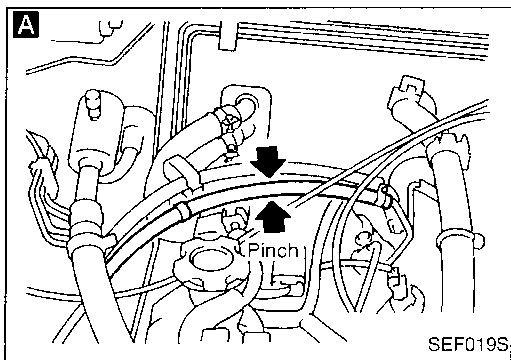

INSPECTION START

A
CHECK OVERALL FUNCTION.
1. Turn ignition switch "ON".
2. Pinch fuel feed hose with fingers.
Fuel pressure pulsation should be felt on the fuel feed hose for 5 seconds after ignition switch is turned "ON".

OK → INSPECTION END

NG ↓

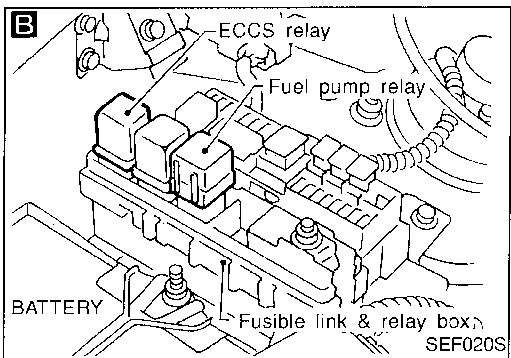

B
CHECK POWER SUPPLY.
1. Turn ignition switch "OFF".
2. Disconnect fuel pump relay.
3. Turn ignition switch "ON".
4. Check voltage between terminals ②, ③ and ground with CONSULT or tester.
Voltage: Battery voltage

NG →
Check the following.
• Harness connectors (E1), (M1)
• 15A fuse
• Harness continuity between fuse and fuel pump relay
If NG, repair harness or connectors.

OK ↓

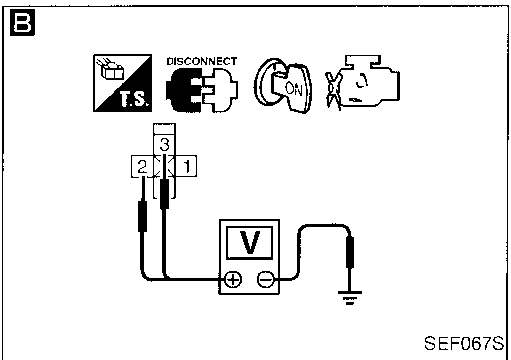

C
CHECK POWER AND GROUND CIRCUIT.
1. Turn ignition switch "OFF".
2. Disconnect fuel pump harness connector.
3. Check harness continuity between terminal ② and body ground, terminal ① and fuel pump relay connector terminal ⑤.
Continuity should exist.

NG →
Check the following.
• Harness connectors (M2), (B1)
• Harness continuity between fuel pump and body ground
• Harness continuity between fuel pump and fuel pump relay
If NG, repair harness or connectors.

OK ↓

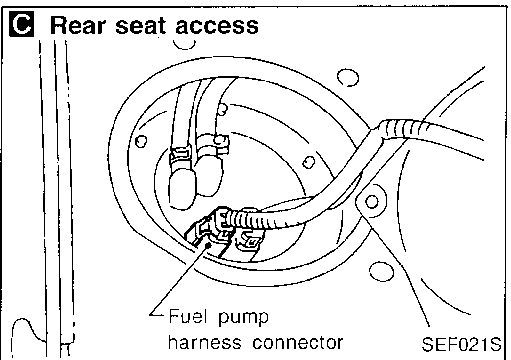

D
CHECK OUTPUT SIGNAL CIRCUIT.
1. Disconnect ECM harness connector.
2. Check harness continuity between ECM terminal ⑥ and fuel pump relay connector terminal ①.
Continuity should exist.

NG →
Check the following.
• Harness connectors (F23), (M32)
• Harness connectors (M1), (E1)
• Harness continuity between ECM and fuel pump relay
If NG, repair harness or connectors.

OK ↓

Ⓐ

CLICK HERE TO **DOWNLOAD** THE COMPLETE MANUAL

- Thank you very much for reading the preview of the manual.
- You can download the complete manual from: www.heydownloads.com by clicking the link below



- Please note: If there is no response to CLICKING the link, please download this PDF first and then click on it.

CLICK HERE TO **DOWNLOAD** THE COMPLETE MANUAL

SECTION **EL**

When you read wiring diagrams:

- Read GI section, "HOW TO READ WIRING DIAGRAMS".

When you perform trouble diagnoses, read GI section, "HOW TO FOLLOW FLOW CHART IN TROUBLE DIAGNOSES" and "HOW TO PERFORM EFFICIENT DIAGNOSIS FOR AN ELECTRICAL INCIDENT".

CONTENTS

PRECAUTIONS	2	Wiring Diagram (For USA) — H/LAMP —	42
Supplemental Restraint System (SRS) "AIR BAG"	2	Trouble Diagnoses (For USA)	43
HARNESS CONNECTOR	3	Daytime Light System/System Description (For Canada)	44
Description	3	Operation (Daytime light system for Canada)	45
STANDARDIZED RELAY	4	Schematic (For Canada)	46
Description	4	Wiring Diagram (For Canada) — DTRL —	47
POWER SUPPLY ROUTING	6	Trouble Diagnoses (For Canada)	50
Schematic	6	Bulb Replacement	51
Wiring Diagram — POWER —	7	Bulb Specifications	51
Fuse	18	Aiming Adjustment	51
Fusible Link	18	EXTERIOR LAMP	53
Circuit Breaker Inspection	18	Parking, License and Tail Lamps/Schematic	53
GROUND DISTRIBUTION	19	Parking, License and Tail Lamps/Wiring Diagram — TAIL/L —	54
BATTERY	22	Stop Lamp/Wiring Diagram — STOP/L —	57
How to Handle Battery	22	Back-up Lamp/Wiring Diagram — BACK/L —	59
Service Data and Specifications (SDS)	25	Front Fog Lamp/System Description	61
STARTING SYSTEM	26	Front Fog Lamp/Wiring Diagram — F/FOG —	62
System Description	26	Front Fog Lamp Aiming Adjustment	63
Wiring Diagram — START —	28	Bulb Specifications	63
Construction	31	Turn Signal and Hazard Warning Lamps/System Description	64
Removal and Installation	31	Turn Signal and Hazard Warning Lamps/Schematic	66
Pinion/Clutch Check	32	Turn Signal and Hazard Warning Lamps/Wiring Diagram — TURN —	67
Service Data and Specifications (SDS)	32	Turn Signal and Hazard Warning Lamps/Trouble Diagnoses	70
CHARGING SYSTEM	33	Combination Flasher Unit Check	70
System Description	33	Bulb Specifications	71
Wiring Diagram — CHARGE —	34	INTERIOR LAMP	72
Trouble Diagnoses	35	Illumination/System Description	72
Construction	36	Illumination/Schematic	73
Removal and Installation	36	Illumination/Wiring Diagram — ILL —	74
Service Data and Specifications (SDS)	37	Interior, Spot and Luggage Room Lamps/System Description	78
COMBINATION SWITCH	38		
Combination Switch/Check	38		
Replacement	39		
Steering Switch/Check	40		
HEADLAMP	41		
System Description (For USA)	41		

POWER SUPPLY ROUTING

Wiring Diagram — POWER — (Cont'd)

EL-POWER-07

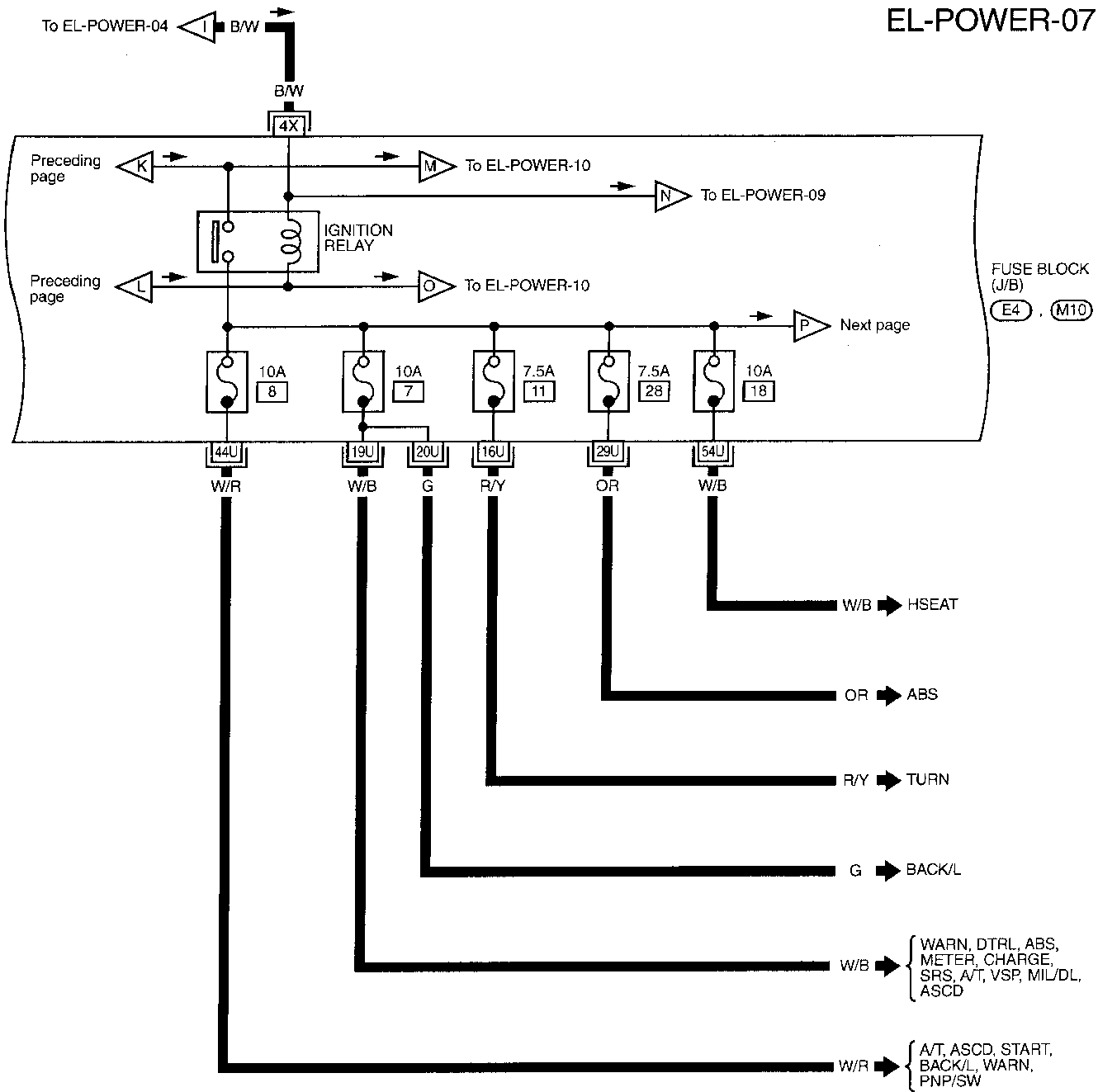

Refer to last page (Foldout page).

(E4)

(M10)

GI

MA

EM

LC

EC

FE

CL

MT

AT

TF

PD

FA

RA

BR

ST

RS

BT

HA

EL

IDX

STARTING SYSTEM

System Description (Cont'd)

A/T MODELS

Power is supplied at all times

- to ignition switch terminal ①
- through 40A fusible link (letter [B], located in the fuse and fusible link box).

With the ignition switch in the ON or START position, power is supplied

- to inhibitor switch terminal ② .
- through 10A fuse [No. [B], located in the fuse block (J/B)].

Ground is supplied

- to inhibitor relay terminal ②
- through body grounds (E13) and (E41)

Models with theft warning system

With the ignition switch in the ON or START position, power is supplied

- through 7.5A fuse [No. [2], located in the fuse block (J/B)]
- to theft warning relay terminal ① .

If the theft warning system is triggered, terminal ② of the theft warning relay is grounded and power to the inhibitor relay terminal ① is interrupted.

When the theft warning system is not operating, power is supplied with ignition switch in the START position

- through inhibitor switch terminal ① ,
- to theft warning relay terminal ③ ,
- through theft warning relay terminal ④ ,
- to inhibitor relay terminal ① , with the selector lever in the P or N position.

Then inhibitor relay is energized and power is supplied

- through ignition switch terminal ⑤ ,
- to inhibitor relay terminal ③ ,
- through inhibitor relay terminal ⑤ ,
- to terminal ② of the starter motor windings.

Models without theft warning system

With the ignition switch in the START position, power is supplied

- through inhibitor switch terminal ① ,
- to inhibitor relay terminal ① , with selector lever in the P or N position.

Then inhibitor relay is energized and power is supplied

- from ignition switch terminal ⑤
- to inhibitor relay terminal ③
- through inhibitor relay terminal ⑤
- to terminal ② of the starter motor windings.

The starter motor plunger closes and provides a closed circuit between the battery and starter motor. The starter motor is grounded to the engine block. With power and ground supplied, cranking occurs and the engine starts.

GI

MA

EM

LC

EC

FE

CL

MT

AT

TF

PD

FA

RA

BR

ST

RS

BT

HA

EL

IDX

HEADLAMP

System Description (For USA)

The headlamps are controlled by the lighting switch which is built into the combination switch.

Power is supplied at all times

- to lighting switch terminal ⑤
- through 15A fuse (No. ⑤9 , located in the fuse and fusible link box), and
- to lighting switch terminal ⑧
- through 15A fuse (No. ⑥0 , located in the fuse and fusible link box).

Low beam operation

When the lighting switch is turned to the 2ND position and placed in LOW ("B") position, power is supplied

- from lighting switch terminal ⑩
- to terminal ② of the LH headlamp, and
- from lighting switch terminal ⑦
- to terminal ② of the RH headlamp.

Terminal ③ of each headlamp supplies ground through body grounds ①3 and ①4.

With power and ground supplied, the headlamp(s) will illuminate.

High beam operation/flash-to-pass operation

When the lighting switch is turned to the 2ND position and placed in HIGH ("A") position or PASS ("C") position, power is supplied

- from lighting switch terminal ⑥
- to terminal ① of each RH headlamp, and
- from lighting switch terminal ⑨
- to terminal ① of each LH headlamp, and
- to combination meter terminal ④3 for the high beam indicator.

Ground is supplied to terminal ③5 of the combination meter through body grounds ①4 and ①7.

Terminal ③ of each headlamp supplies ground through body grounds ①3 and ①4.

With power and ground supplied, the high beams and the high beam indicator illuminate.

Theft warning system

The theft warning system will flash the high beams if the system is triggered. Refer to "THEFT WARNING SYSTEM" (EL-215).

GI

MA

EM

LC

EC

FE

CL

MT

AT

TF

PD

FA

RA

BR

ST

RS

BT

HA

EL

IDX

EXTERIOR LAMP

Parking, License and Tail Lamps/Wiring Diagram — TAIL/L — (Cont'd)

EL-TAIL/L-02

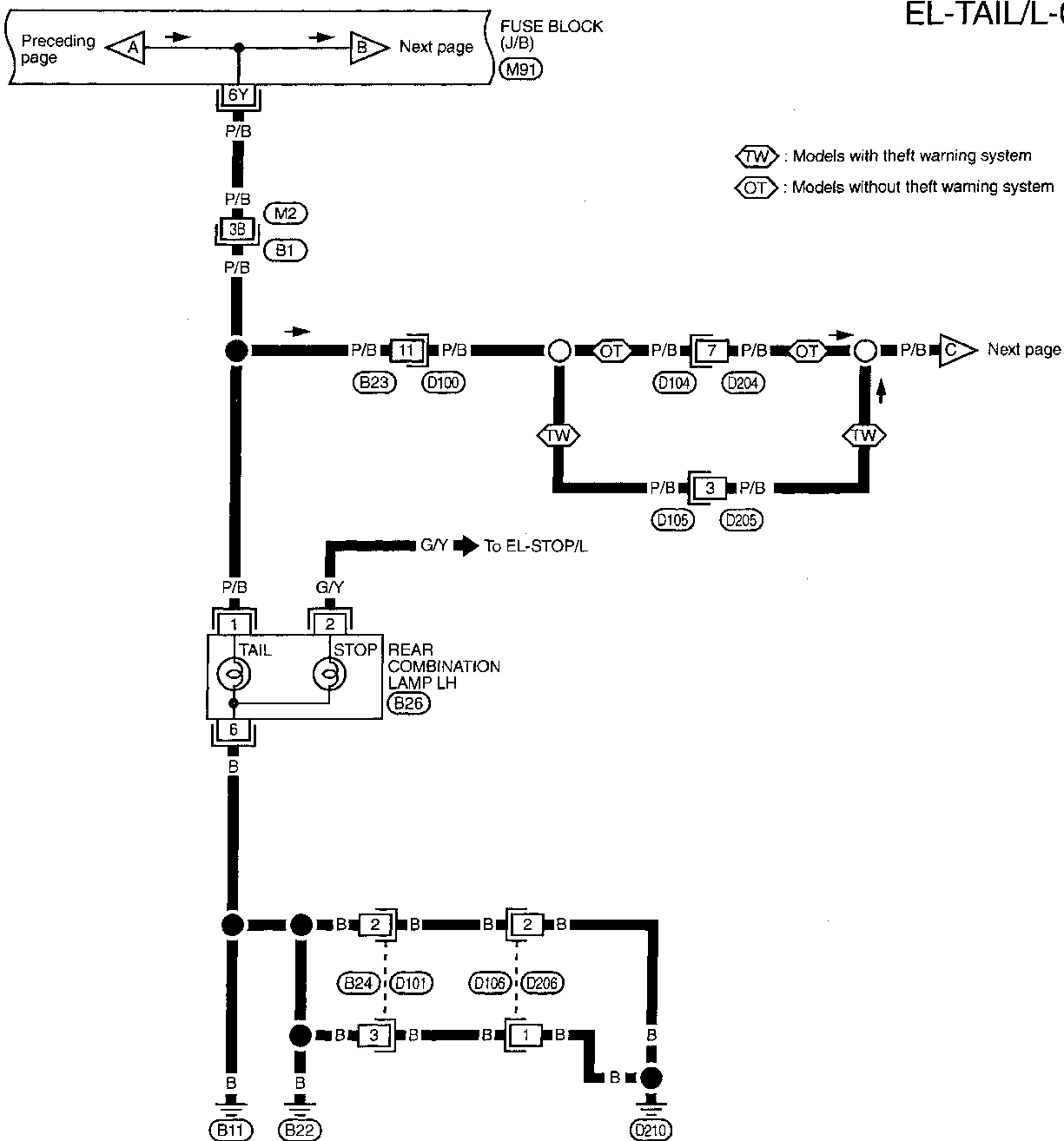

TW : Models with theft warning system
OT : Models without theft warning system

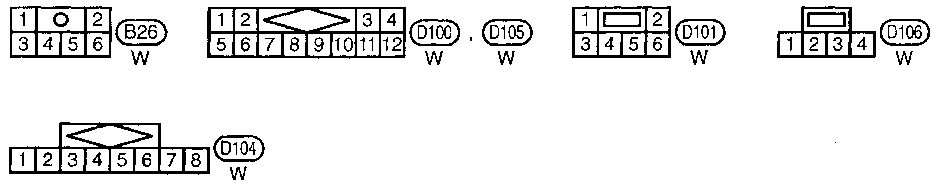

Refer to last page (Foldout page).

M91
M2 B1

GI
 MA
 EM
 LC
 EC
 FE
 CL
 MT
 AT
 TF
 PD
 FA
 RA
 BR
 ST
 RS
 BT
 HA
EL
 IDX

EXTERIOR LAMP

Turn Signal and Hazard Warning Lamps/Wiring Diagram — TURN — (Cont'd)

EL-TURN-03

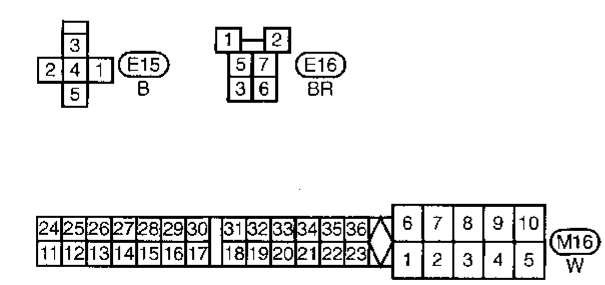
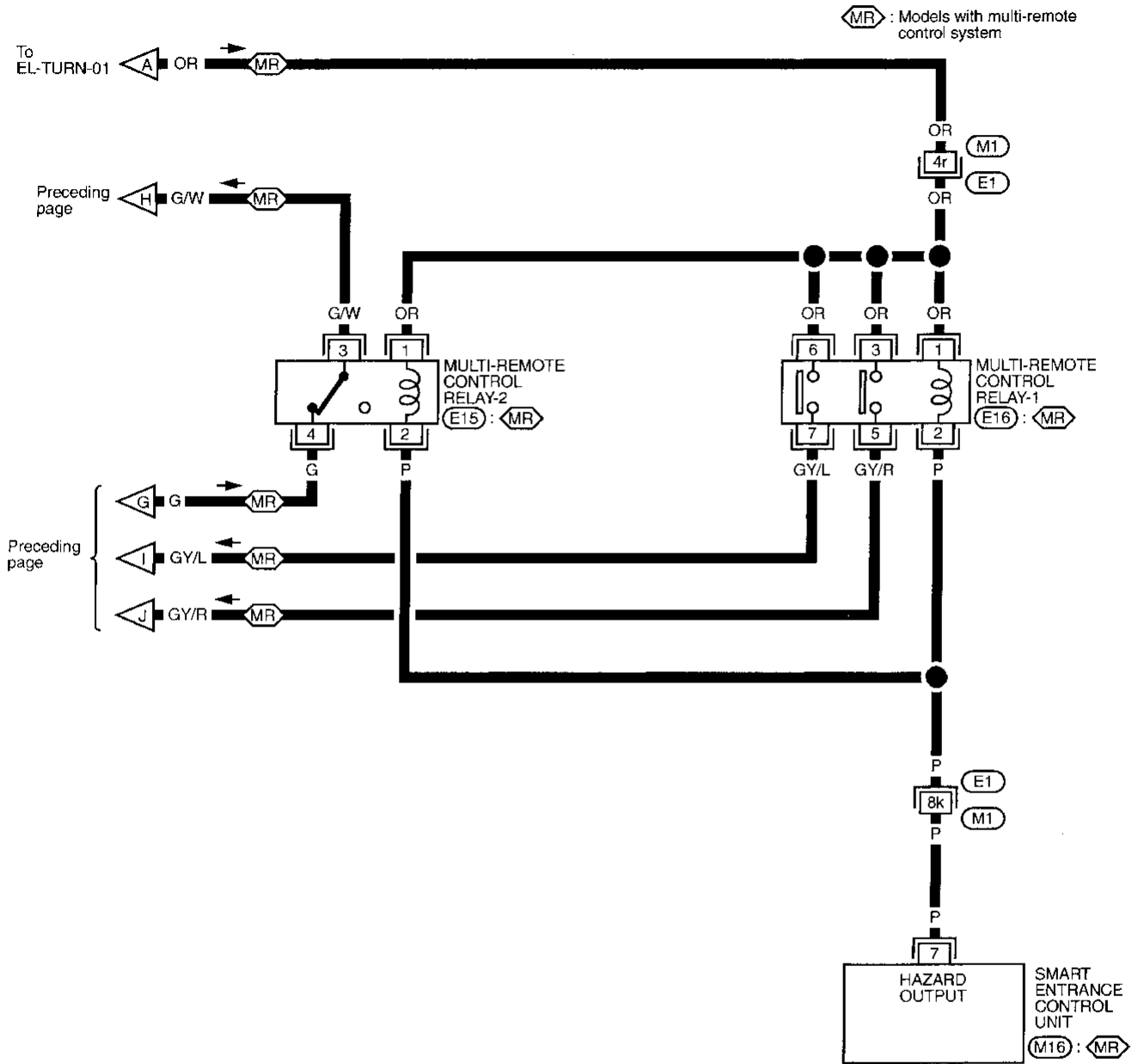

Refer to last page (Foldout page).
E1 M1

GI
MA
EM
LC
EC
FE
CL
MT
AT
TF
PD
FA
RA
BR
ST
RS
BT
HA
EL
IDX

System Description

With the ignition switch in the ON or START position, power is supplied

- through 10A fuse [No. 7], located in the fuse block (J/B)
- to combination meter terminal 15.

Ground is supplied

- to combination meter terminals 23 and 35
- through body grounds M4 and M77.

WATER TEMPERATURE GAUGE

The water temperature gauge indicates the engine coolant temperature. The reading on the gauge is based on the resistance of the thermal transmitter.

As the temperature of the coolant increases, the resistance of the thermal transmitter decreases. A variable ground is supplied to terminal 37 of the combination meter for the water temperature gauge. The needle on the gauge moves from "C" to "H".

TACHOMETER

The tachometer indicates engine speed in revolutions per minute (rpm).

The tachometer is regulated by a signal

- from terminal 3 of the ECM (ECCS control module)
- to combination meter terminal 32 for the tachometer.

FUEL GAUGE

The fuel gauge indicates the approximate fuel level in the fuel tank.

The fuel gauge is regulated by a variable ground signal supplied

- to combination meter terminal 6 for the fuel gauge
- from terminal 3 of the fuel tank gauge unit
- through terminal 2 of the fuel tank gauge unit and
- through body grounds B11, B22 and D210.

SPEEDOMETER

The vehicle speed sensor provides a voltage signal to the combination meter for the speedometer.

The voltage is supplied

- to combination meter terminals 8 and 12 for the speedometer
- from terminals 2 and 1 of the vehicle speed sensor.

The speedometer converts the voltage into the vehicle speed displayed.

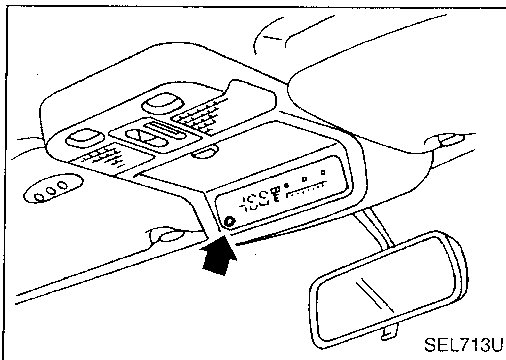

COMPASS AND THERMOMETER

This unit is a display unit which possesses the following functions:

- Function to measure earth magnetism and indicate heading direction of vehicle.
- Function to indicate outside air temperature.
- Function to indicate caution for frozen road surfaces.

Outside temperature display

Push the switch when the ignition key is in the "ACC" or "ON" position. The outside temperature will be displayed in "°F".

- Selecting the indication range
Push the switch to change from "°F" to "°C".
- When the outside temperature drops below freezing point, ICE is displayed on the unit.
- When the outside temperature is between 55°C (130°F) and 70°C (158°F), the display shows 55°C (130°F).
- When the outside temperature is lower than -30°C (-20°F) or higher than 70°C (158°F), the display shows only "---" though it is operating. This is not a problem.

Direction display

Push the switch when the ignition key is in the "ACC" or "ON" position. The direction will be displayed.

GI

MA

EM

LC

EC

FE

CL

MT

AT

TF

PD

FA

RA

BR

ST

RS

BT

HA

EL

IDX

WARNING LAMPS

Warning Lamps/Wiring Diagram — WARN — (Cont'd)

EL-WARN-02

GI
MA
EM
LC
EC
FE
CL
MT
AT
TF
PD
FA
RA
BR
ST
RS
BT
HA
EL
IDX

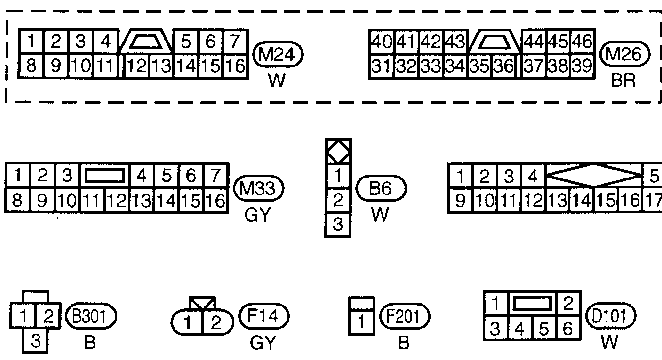
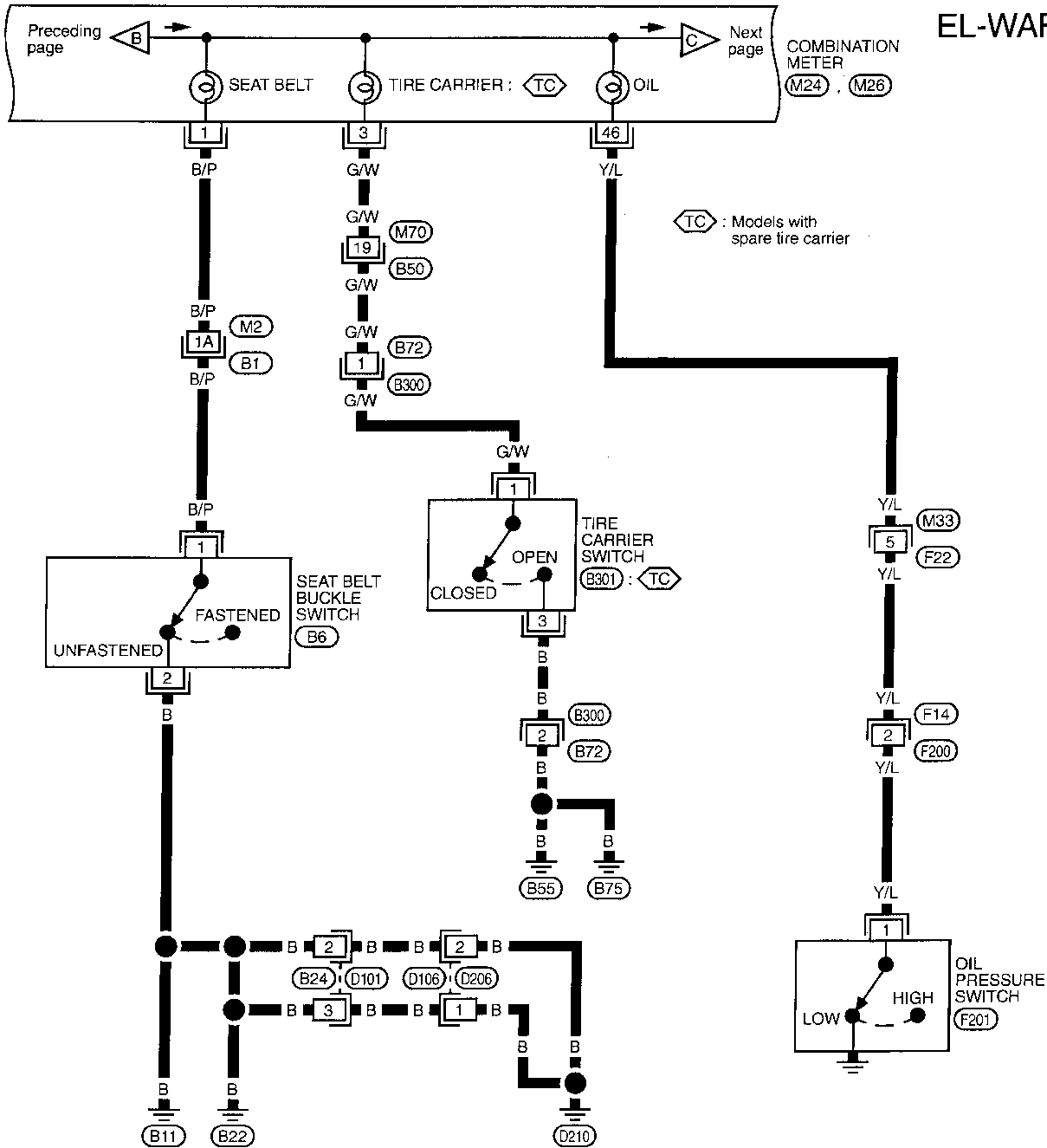

Refer to last page (Foldout page).
(M2) , (B1)

System Description

WIPER OPERATION

The wiper switch is controlled by a lever built into the combination switch. There are three wiper switch positions:

- LO speed
- HI speed
- INT (Intermittent)

With the ignition switch in the ACC or ON position, power is supplied

- through 20A fuse [No. 19], located in the fuse block (J/B)]
- to wiper motor terminal 6.

Low and high speed wiper operation

Ground is supplied to wiper switch terminal 17 through body grounds E13 and E41.

When the wiper switch is placed in the LO position, ground is supplied

- through terminal 14 of the wiper switch
- to wiper motor terminal 2.

With power and ground supplied, the wiper motor operates at low speed.

When the wiper switch is placed in the HI position, ground is supplied

- through terminal 16 of the wiper switch
- to wiper motor terminal 1.

With power and ground supplied, the wiper motor operates at high speed.

Auto stop operation

With wiper switch turned OFF, wiper motor will continue to operate until wiper arms reach windshield base.

When wiper arms are not located at base of windshield with wiper switch OFF, ground is provided

- from terminal 14 of the wiper switch
- to wiper motor terminal 2, in order to continue wiper motor operation at low speed.

Ground is also supplied

- through terminal 13 of the wiper switch
- to wiper amplifier terminal 2
- through terminal 7 of the wiper amplifier
- to wiper motor terminal 5
- through terminal 4 of the wiper motor, and
- through body grounds M4 and M77.

When wiper arms reach base of windshield, wiper motor terminals 4 and 6 are connected instead of terminals 4 and 5. Wiper motor will then stop wiper arms at the PARK position.

Intermittent operation

The wiper motor operates the wiper arms one time at low speed at a set interval of approximately 3 to 13 seconds. This feature is controlled by the wiper amplifier.

When the wiper switch is placed in the INT position, ground is supplied

- to wiper amplifier terminal 1
- from wiper switch terminal 15
- through body grounds E13 and E41.
- to wiper motor terminal 2
- through the wiper switch terminal 14
- to wiper switch terminal 13
- through wiper amplifier terminal 2
- to wiper amplifier terminal 3
- through body grounds M4 and M77.

The desired interval time is input

- to wiper amplifier terminal 8
- from wiper switch terminal 19.

The wiper motor operates at low speed at the desired time interval.

GI

MA

EM

LC

EC

FE

CL

MT

AT

TF

PD

FA

RA

BR

ST

RS

BT

HA







EL

IDX

WIPER AND WASHER

Rear Wiper/Trouble Diagnoses

REAR WIPER AMP. INSPECTION TABLE
(Data are reference values.)

Terminal No.	Item	Condition		Voltage (Approximate value)	
1	Amp. ON signal		Rear wiper switch	ON or INT	1V or less
				OFF	Approx. 12
2	Wiper amp. output		Rear wiper switch "INT"	Wiper is moving	1V or less
				Wiper stop	Approx. 12
3	Ground	—		—	
4	Rear wiper motor		Rear wiper switch	ON, INT or WASH	Approx. 12
				OFF	1V or less
5	Power supply (See NOTE)		Rear glass hatch	OPENED	0V
				CLOSED	Approx. 12
6	Washer switch		Rear wiper switch	WASH	1V or less
				OFF	Approx. 12
7	Auto stop		Rear wiper switch "ON" or "INT"	Wiper is moving	1V or less
				Wiper stop	Approx. 12

NOTE: Power to the rear wiper amp. will be interrupted when the rear glass hatch is opened. In that case, conduct the inspection of the rear wiper amp. with the rear glass hatch closed, unless otherwise indicated.

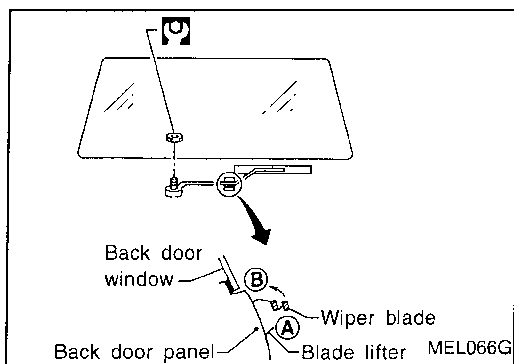

Rear Wiper Installation and Adjustment

- Prior to wiper arm installation, turn on wiper switch to operate wiper motor and then turn it "OFF" (Auto Stop).
- Install wiper arm to portion (A) as in figure below and tighten wiper arm nut to specification.
- Then, set wiper arm to portion (B).
: 13 - 18 N·m (1.3 - 1.8 kg-m, 9 - 13 ft-lb)

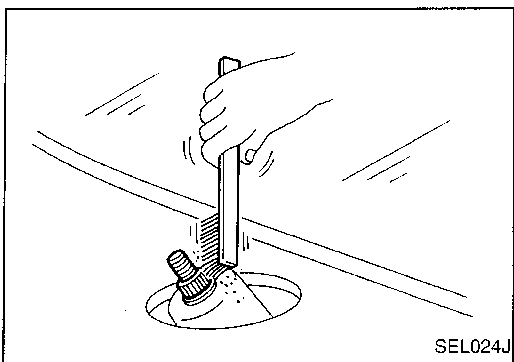

- Before reinstalling wiper arm, clean up the pivot area as illustrated. This will reduce possibility of wiper arm looseness.

GI
MA
EM
LC
EC
FE
CL
MT
AT
TF
PD
FA
RA
BR
ST
RS
BT
HA
EL
IDX

AUDIO AND POWER ANTENNA

Audio (With speaker amp.)/Schematic

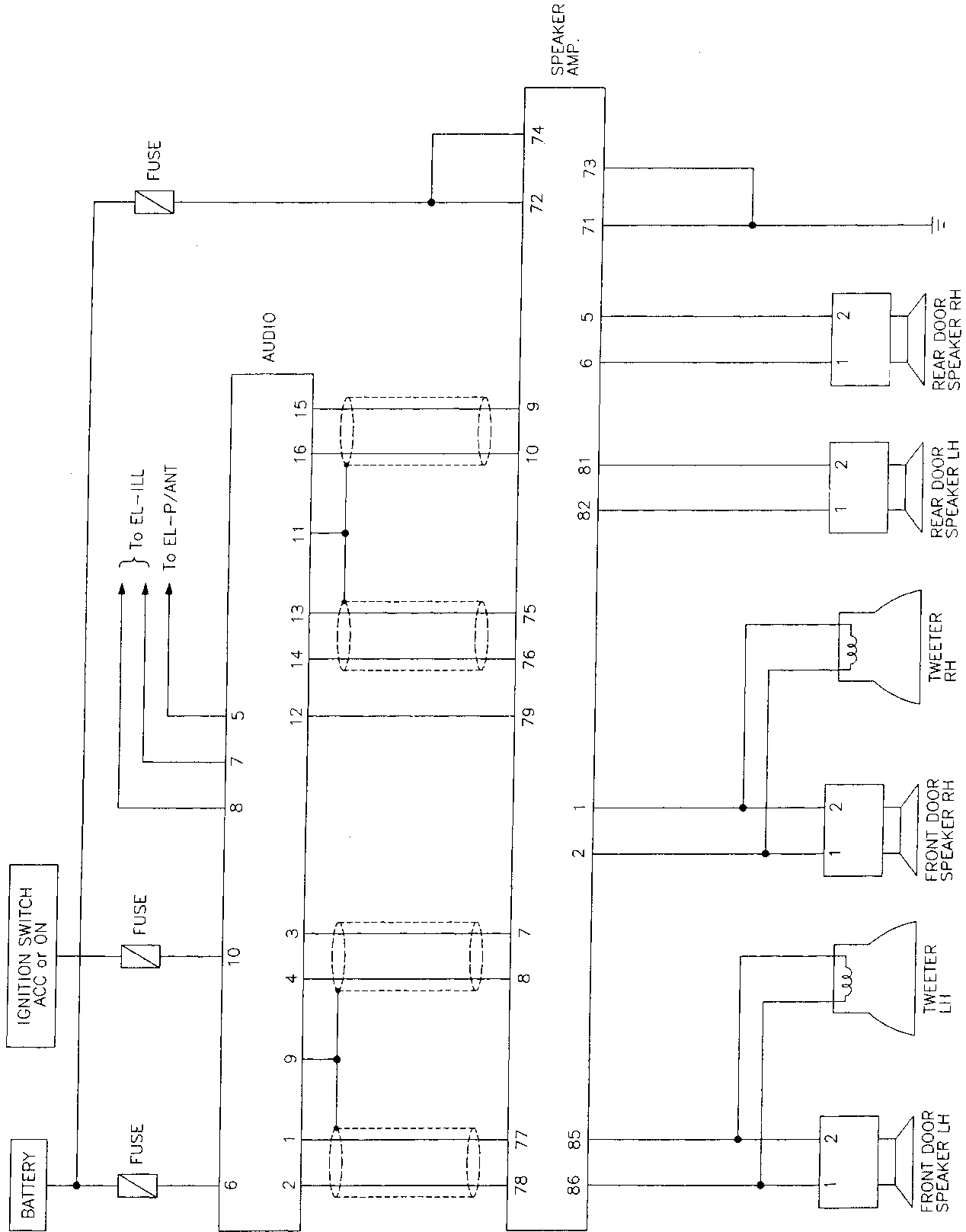

- GI
- MA
- EM
- LC
- EC
- FE
- CL
- MT
- AT
- TF
- PD
- FA
- RA
- BR
- ST
- RS
- BT
- HA
- EL**
- IDX

AUDIO AND POWER ANTENNA

Trouble Diagnoses

RADIO

Symptom	Possible causes	Repair order
Radio inoperative (no digital display and no sound from speakers).	<ol style="list-style-type: none"> 10A fuse Poor radio case ground Radio 	<ol style="list-style-type: none"> Check 10A fuse [No. 10], located in fuse block (J/B). Turn ignition switch ON and verify that battery positive voltage is present at terminal ⑩ of radio. Check radio case ground. Remove radio for repair.
Radio presets are lost when ignition switch is turned OFF.	<ol style="list-style-type: none"> 7.5A fuse (except for BOSE system) 15A fuse (for BOSE system) Radio 	<ol style="list-style-type: none"> Check 7.5/15A fuse [No. 24/4], located in fuse block (J/B) and verify that battery positive voltage is present at terminal ⑥ of radio. Remove radio for repair.
AM stations are weak or noisy (FM stations OK).	<ol style="list-style-type: none"> Antenna Poor radio ground Radio 	<ol style="list-style-type: none"> Check antenna. Check radio ground. Remove radio for repair.
FM stations are weak or noisy (AM stations OK).	<ol style="list-style-type: none"> Window antenna Radio 	<ol style="list-style-type: none"> Check window antenna. Remove radio for repair.
Radio generates noise in AM and FM modes with engine running.	<ol style="list-style-type: none"> Poor radio ground Loose or missing ground bonding straps Ignition condenser or rear window defogger noise suppressor condenser Alternator Ignition coil or secondary wiring Radio 	<ol style="list-style-type: none"> Check radio ground. Check ground bonding straps. Replace ignition condenser or rear window defogger noise suppressor condenser. Check alternator. Check ignition coil and secondary wiring. Remove radio for repair.
Radio generates noise in AM and FM modes with accessories on (switch pops and motor noise).	<ol style="list-style-type: none"> Poor radio ground Antenna Accessory ground Faulty accessory 	<ol style="list-style-type: none"> Check radio ground. Check antenna. Check accessory ground. Replace accessory.

MODELS WITH SPEAKER AMP.

Symptom	Possible causes	Repair order
Radio controls are operational, but no sound is heard from any speaker.	<ol style="list-style-type: none"> 15A fuse Speaker amp. ground circuit Speaker amp. Speaker amp. circuit Radio 	<ol style="list-style-type: none"> Check 15A fuse [No. 4], located in fuse block (J/B). Verify that battery positive voltage is present at terminals ⑭ and ⑮ of speaker amp. Check speaker amp. ground circuit. Check speaker amp. voltages. Check wires for open or short between radio, speaker amp. and speakers. Remove radio for repair.
Individual speaker is noisy or inoperative.	<ol style="list-style-type: none"> Speaker Radio/amp. output Speaker circuit Radio 	<ol style="list-style-type: none"> Check speaker. Check radio/amp. output voltages. Check wires for open or short between radio/amp. and speaker. Remove radio for repair.

GI

MA

EM

LC

EC

FE

CL

MT

AT

TF

PD

FA

RA

BR

ST

RS

BT

HA

EL

IDX

AUTOMATIC SPEED CONTROL DEVICE (ASCD)

Wiring Diagram — ASCD — (Cont'd)

EL-ASCD-02

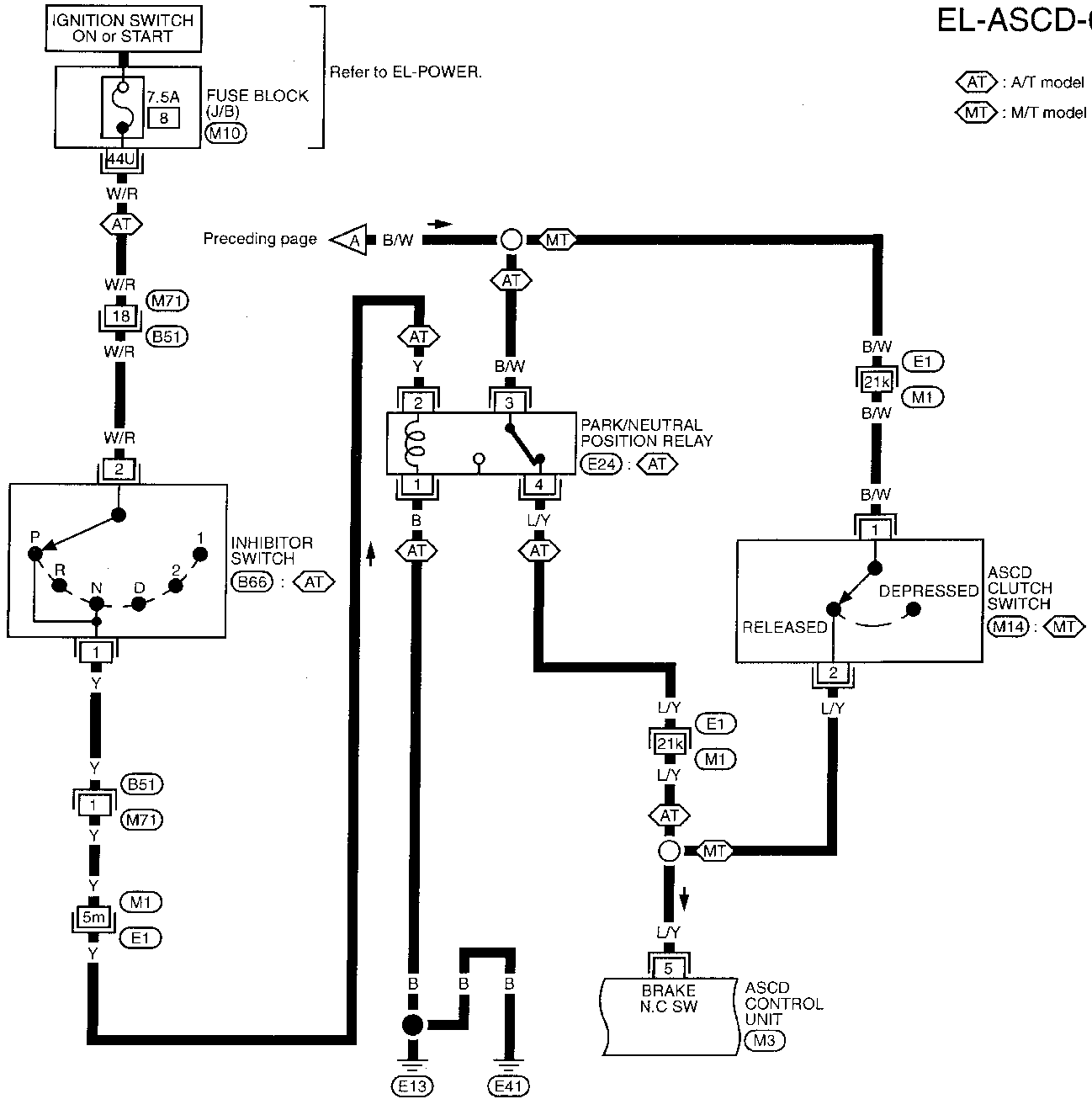

GI
MA
EM
LC
EC
FE
CL
MT
AT
TF
PD
FA
RA
BR
ST
RS
BT
HA
EL
DX

Refer to last page (Foldout page).

E1 , M1
M10

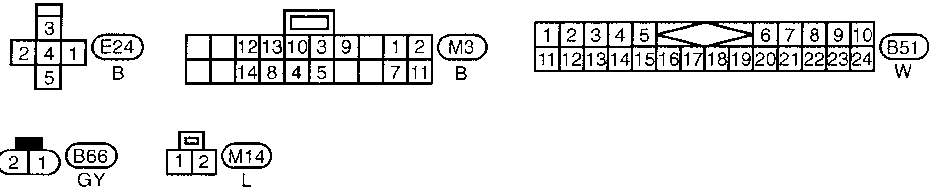

ASCD Wire Adjustment

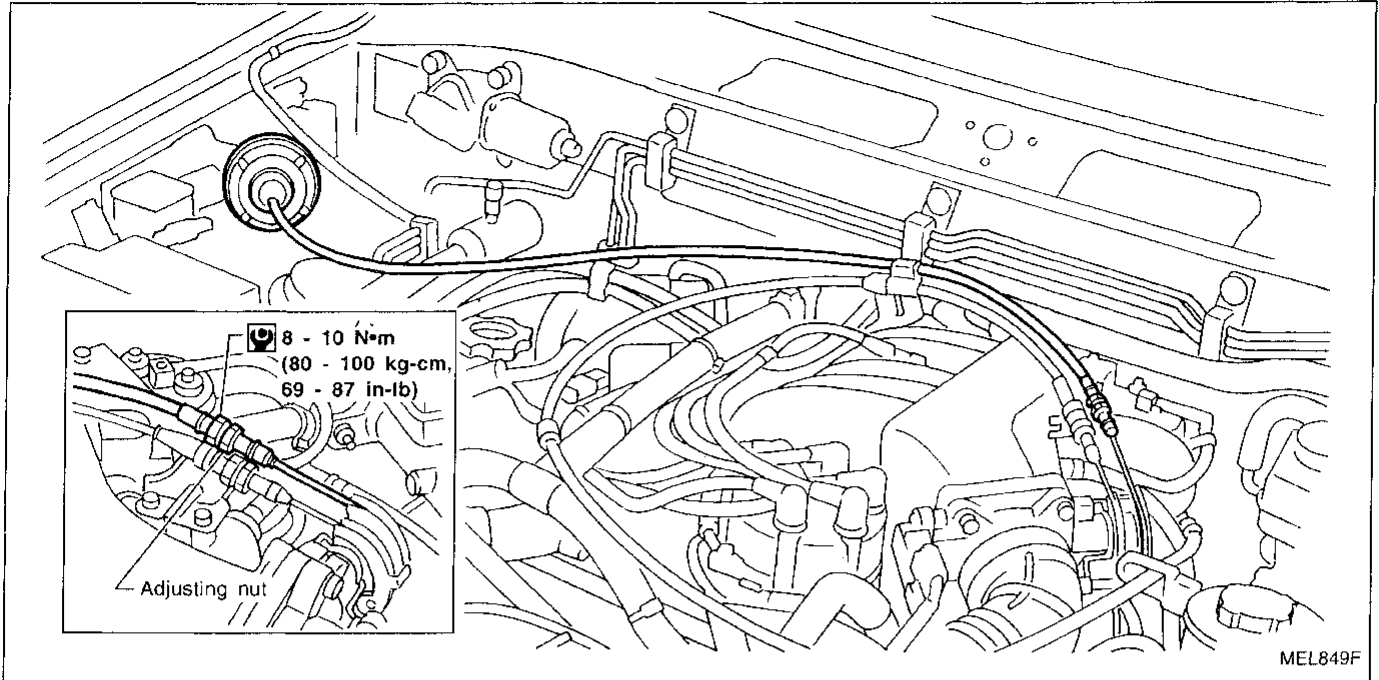

CAUTION:

- Be careful not to twist ASCD wire when removing it.
- Do not tense ASCD wire excessively during adjustment.

Adjust the tension of ASCD wire in the following manner.

- (1) Loosen lock nut and adjusting nut.
- (2) Make sure that accelerator wire is properly adjusted. Refer to FE section ("ACCELERATOR CONTROL SYSTEM").
- (3) Tighten adjusting nut just until throttle drum starts to move.
- (4) Loosen adjusting nut again 1/2 to 1 turn.
- (5) Tighten lock nut.

GI

MA

EM

LC

EC

FE

CL

MT

AT

TF

PD

FA

RA

BR

ST

RS

BT

HA

EL

DX

POWER DOOR LOCK

Wiring Diagram — D/LOCK — (Cont'd)

EL-D/LOCK-03

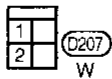
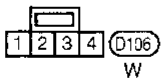
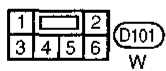
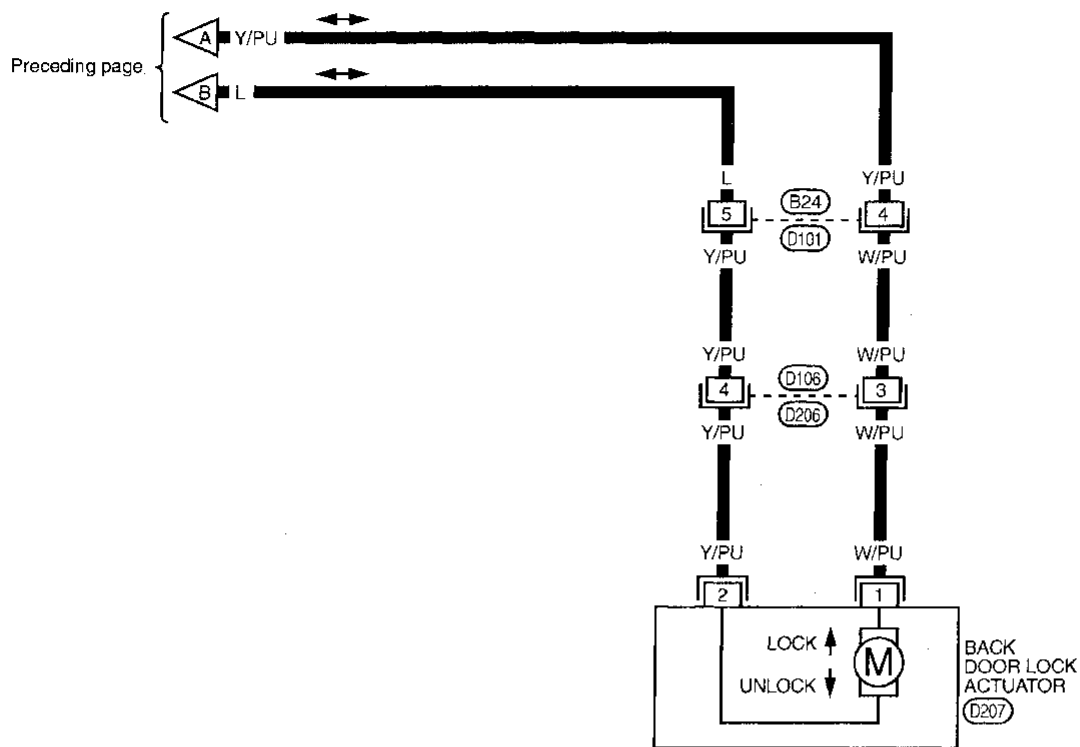

GI

MA

EM

LC

EC

FE

CL

MT

AT

TF

PD

FA

RA

BR

ST

RS

BT

HA

EL

IDX

MULTI-REMOTE CONTROL SYSTEM

Trouble Diagnoses (Cont'd)

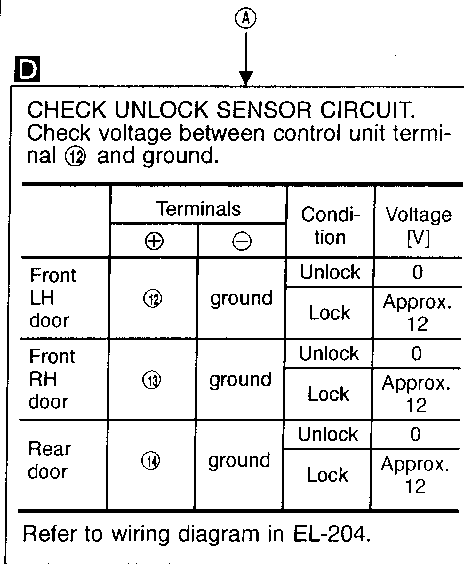
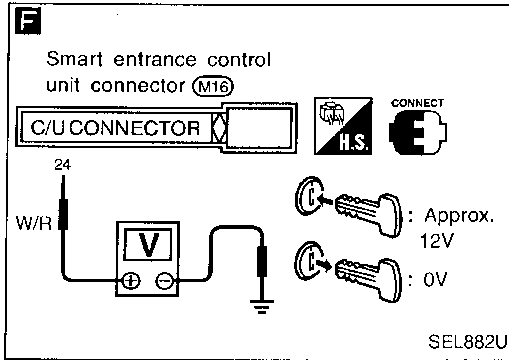
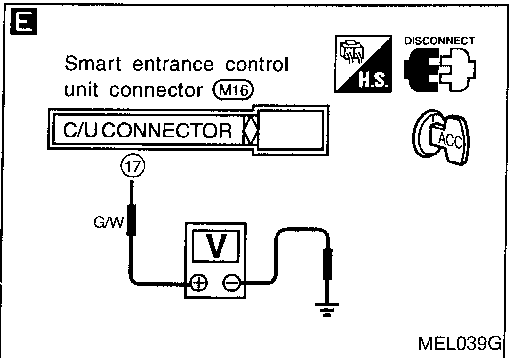
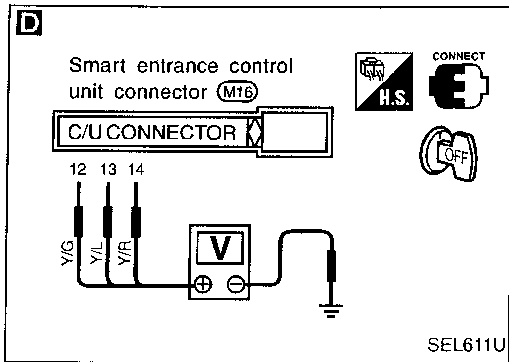

- Check the following.
- Door unlock sensor
 - Refer to "ELECTRICAL COMPONENTS INSPECTION" (EL-212).
 - Door unlock sensor ground circuit
 - Harness for open or short between control unit and unlock sensor

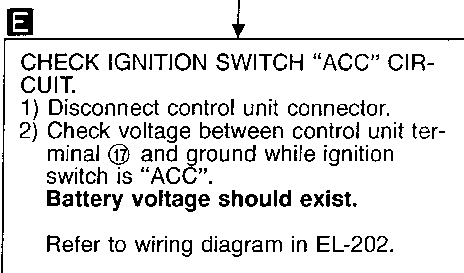

- Check the following.
- 10A fuse [No. ⑩], located in fuse block (J/B)
 - Harness for open or short between control unit and fuse

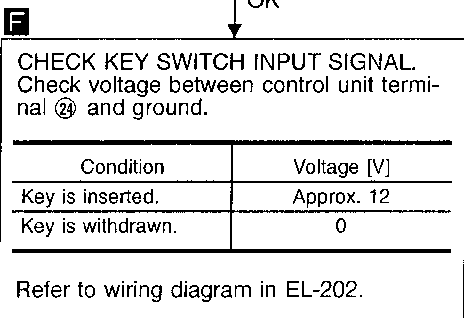

- Check the following.
- 7.5A fuse [No. ⑳], located in fuse block (J/B)
 - Key switch
 - Refer to "ELECTRICAL COMPONENTS INSPECTION" (EL-212).
 - Harness for open or short between key switch and fuse
 - Harness for open or short between control unit and key switch

Check operation parts in multi-remote control system for function.

GI
MA
EM
LC
EC
FE
CL
MT
AT
TF
PD
FA
RA
BR
ST
RS
BT
HA
EL
IDX

THEFT WARNING SYSTEM

Trouble Diagnoses (Cont'd)

DIAGNOSTIC PROCEDURE 7 (Theft warning headlamp alarm check)

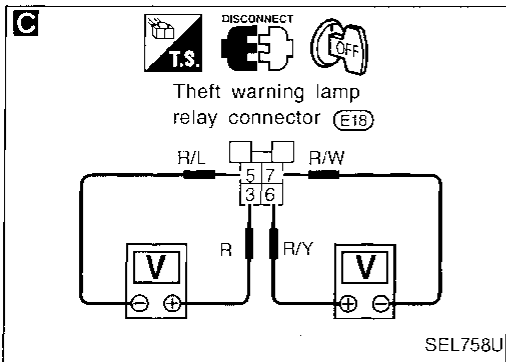
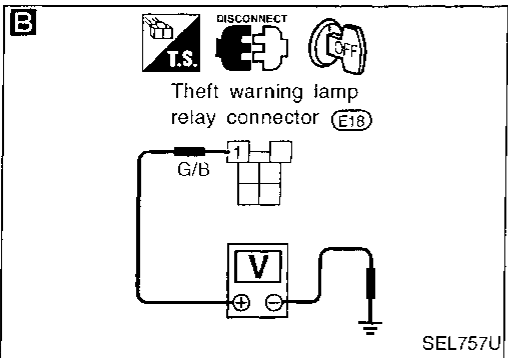
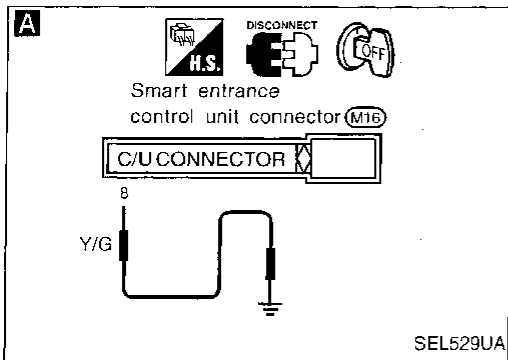

A

CHECK THEFT WARNING HEADLAMP ALARM OPERATION.

1. Disconnect control unit connector.
2. Apply ground to control unit terminal ⑧.

Does headlamp alarm activate?

Refer to wiring diagram in EL-224.

Yes → Headlamp alarm is OK.

No

Does headlamp come on when turning lighting switch "ON"?

No → Check headlamp system. Refer to "HEADLAMP".

Yes

Check theft warning lamp relay.

NG → Replace.

OK

B

CHECK POWER SUPPLY FOR THEFT WARNING LAMP RELAY.

1. Disconnect theft warning lamp relay connector.
2. Check voltage between terminal ① and ground.

Positive battery voltage should exist.

Refer to wiring diagram in EL-225.

NG → Check the following.

- 7.5A fuse (No. 52, located in the fuse and fusible link box)
- Harness for open or short between theft warning lamp relay and fuse

OK

C

CHECK THEFT WARNING LAMP RELAY CIRCUIT.

1. Disconnect theft warning lamp relay connector.
2. Check voltage between terminals ③ and ⑤.

Positive battery voltage should exist.

NG → Check harness for open or short.

3. Check voltage between terminals ⑥ and ⑦.

Positive battery voltage should exist.

OK

Check harness for open or short between theft warning lamp relay and ground.

GI

MA

EM

LC

EC

FE

CL

MT

AT

TF

PD

FA

RA

BR

ST

RS

BT

HA

EL

IDX

HARNESS LAYOUT

Main Harness (Cont'd)

B4★ M1 B4★ M2 B4 M3 A3 M4 B4 M5 A3 M6 A3 M7 B2 M8 C4 M9 B3★ M10 C4 M11 B3★ M12 B4★ M13 B4 M14 C3 M15 C2 M16 C3 M17 C4 M18 C4 M19 C3 M20 B2 M21 B2 M22 B2 M23 D1★ M24 D1★ M25 D1 M26 C1 M27 C3 M28 C3 M29 C3 M31 D3★ M32 D3★ M33 D3 M34 D2 M35 D3 M36 D4 M37 E2 M39 F2 M40	: To E1 : To B1 : ASCD control unit : Body ground : To D3 : To D4 : Diode : Tweeter LH : Data link connector for GST : Fuse block (J/B) : Data link connector for CONSULT : Diode : A/T control unit : ASCD control switch : Combination flasher unit : Smart entrance control unit : Door mirror remote control switch : ASCD main switch : Illumination control switch : Security indicator lamp (With theft warning system) : Circuit breaker-1 : Circuit breaker-2 (With power seat) : Power window relay : Combination meter : Combination meter : Combination meter : Warning buzzer : Clutch interlock switch (For M/T model) : ASCD brake switch : Brake lamp switch : To F23 : To F22 : In-vehicle sensor (With auto A/C) : Hazard switch : Rear window defogger switch : Joint connector : A/C mode switch : A/C auto amp.	SMJ SMJ B/20 — W/16 W/10 W/2 BR/2 W/16 SMJ GY/14 SB/6 W/48 L/2 B/3 W/36 GY/12 W/6 W/3 W/4 W/2 W/2 L/4 W/16 W/14 BR/16 W/3 L/2 L/2 B/2 W/24 GY/16 W/2 W/8 W/6 GY/6 BR/4 B/12	: A/C auto amp. (For auto A/C) : Recirculation switch : Fan switch : A/C switch : A/C switch illumination : Thermo control amp. : To Z1 : Audio : Audio : Rear wiper switch : Heated seat switch LH : Heated seat switch RH : ABS control unit : Air mix door motor : Cigarette lighter socket : Cigarette lighter illumination : Sunload sensor : Intake door motor : Fan control amp. (For auto A/C) : Fan resistor : To R1 : To R2 : Tweeter RH : Diode : Body ground : To D33 : To D34 : Power antenna motor : To B50 : To B51 : To B52 : Blower motor : ABS actuator : ABS actuator : ABS actuator : Body ground : Front wiper motor : Front wiper amp.	B/16 W/4 W/6 W/3 W/3 BR/4 Y/12 W/10 W/6 W/12 L/4 W/4 B/88 B/6 B/2 W/2 B/2 W/4 W/4 BR/4 W/6 W/6 BR/2 W/2 — W/12 W/6 W/6 W/3 W/20 W/24 W/16 W/2 B/6 GY/8 W/2 — W/6 W/8	M81 M90 M91 M92 M93 M94 M95 M97 M101	B/2 W/2 W/12 B/2 W/4 W/18 — BR/4 BR/6	A3 D2 B3 E3 D2 D3★ D4 A4 G2	: Fuse block (J/B) : Diode : Fuse block (J/B) : Audio option connector (Not used) : Audio option connector (Not used) : To F27 : Body ground (For ABS) : To D11 : To D45
--	---	--	---	--	--	---	---	--

★ : Be sure to connect and lock the connectors securely after repair work. Failure to do so may cause the ECM to have diagnostic trouble codes.

Do not disconnect these connectors except in the case of working according to WORK FLOW of TROUBLE DIAGNOSES in EC and AT sections.

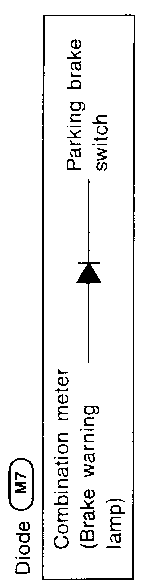
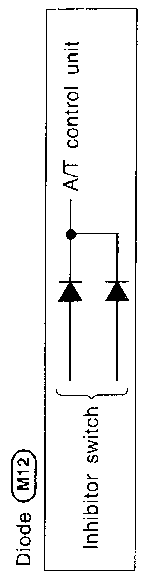
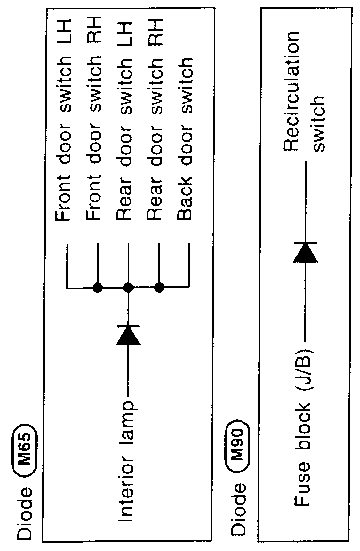

- EL
- HA
- BT
- PG
- ST
- BR
- RA
- FA
- PD
- TF
- AT
- MT
- GL
- EC
- LC
- EM
- MA
- CI

PRECAUTIONS

Parts Requiring Angular Tightening

- Use an angle wrench for the final tightening of the following engine parts:
 - (1) Cylinder head bolts
 - (2) Main bearing cap bolts
 - (3) Connecting rod cap nuts
 - (4) Crankshaft pulley bolt
- Do not use a torque value for final tightening.
- The torque value for these parts are for a preliminary step.
- Ensure thread and seat surfaces are clean and coated with engine oil.

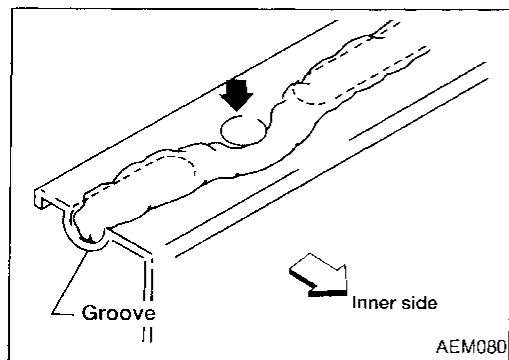
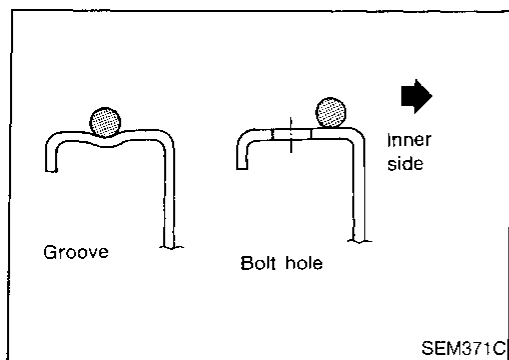

Liquid Gasket Application Procedure

- Use a scraper to remove all traces of old liquid gasket from mating surfaces and grooves. Also completely clean any oil stains from these portions.
- Apply a continuous bead of liquid gasket to mating surfaces. (Use Genuine Liquid Gasket or equivalent.)
 - Be sure liquid gasket is 3.5 to 4.5 mm (0.138 to 0.177 in) dia. (for oil pan).
 - Be sure liquid gasket is 2.0 to 3.0 mm (0.079 to 0.118 in) dia. (in areas except oil pan).
- Apply liquid gasket to inner surface around hole perimeter area (unless otherwise specified).
- Assembly should be done within 5 minutes after coating.
- Wait at least 30 minutes before refilling engine oil and engine coolant.

TIMING BELT

Installation (Cont'd)

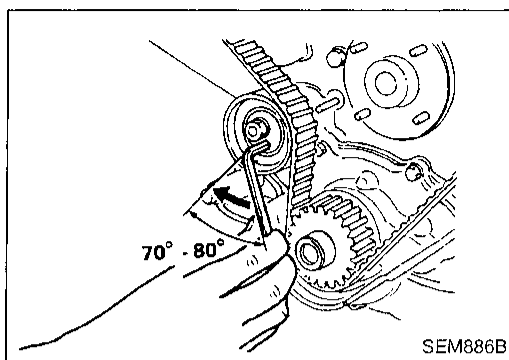

5. Loosen tensioner lock nut, keeping tensioner steady with hexagon wrench.
6. Turn tensioner 70 to 80 degrees clockwise with hexagon wrench, and temporarily tighten lock nut.
7. Turn crankshaft clockwise at least 2 times, then slowly set No. 1 piston at TDC on its compression stroke.

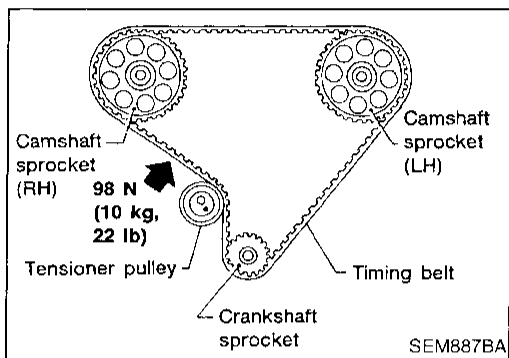

8. Push middle of timing belt between RH camshaft sprocket and tensioner pulley with force of 98 N (10 kg, 22 lb).
9. Loosen tensioner lock nut, keeping tensioner steady with hexagon wrench.

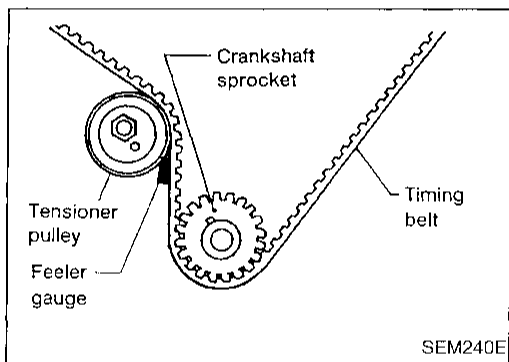

10. Set feeler gauge as shown in figure which is 0.35 mm (0.0138 in) thick and 12.7 mm (0.500 in) wide.

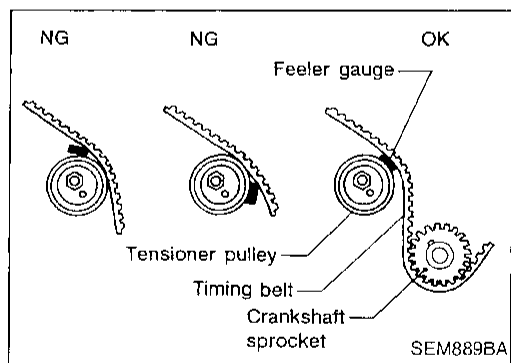

11. Turn crankshaft clockwise until feeler gauge is positioned as shown in figure.
 - Timing belt will move about 2.5 teeth.
12. Tighten tensioner lock nut, keeping tensioner steady with hexagon wrench.
13. Turn crankshaft clockwise or counterclockwise, and remove feeler gauge.
14. Turn crankshaft clockwise at least 2 times, then slowly set No. 1 piston at TDC on its compression stroke.
15. Install lower and upper belt covers.

CYLINDER HEAD

Assembly (Cont'd)

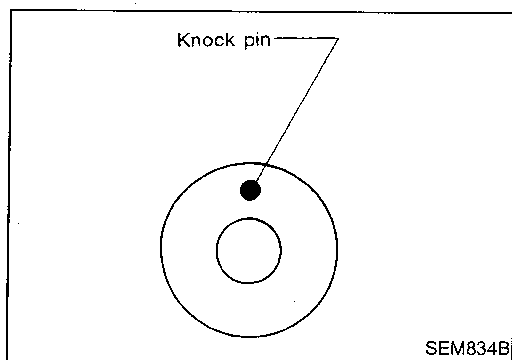

2. Install camshafts, locate plates and cylinder head rear covers.
 - **Set knock pin of camshaft at the top.**

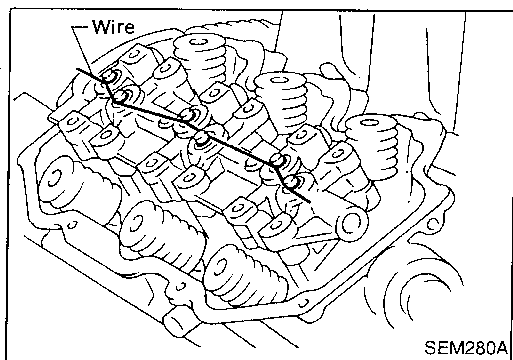

3. Install valve lifters into valve lifter guide.
 - **Assemble valve lifters to their original position and hold all valve lifters with wire to prevent lifters from falling off.**
 - **After installing, remove the wire.**

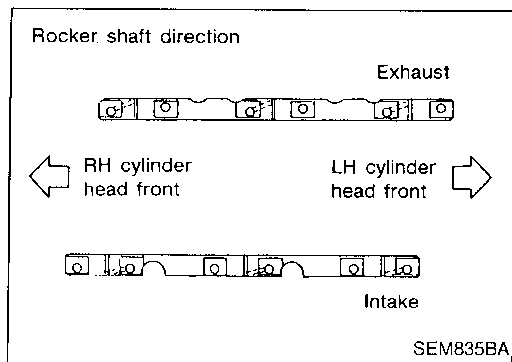

4. Install rocker shafts with rocker arms.
 - **Tighten bolts gradually in two or three stages.**
 - **Before tightening, be sure to set camshaft the lobe at the position where lobe is not lifted.**
 - a. Set No. 1 piston at TDC on its compression stroke and tighten rocker shaft bolts for No. 2, No. 4 and No. 6 cylinders.
 - b. Set No. 4 piston at TDC on its compression stroke and tighten rocker shaft bolts for No. 1, No. 3 and No. 5 cylinders.
5. Install exhaust manifold to cylinder head in reverse order of removal.

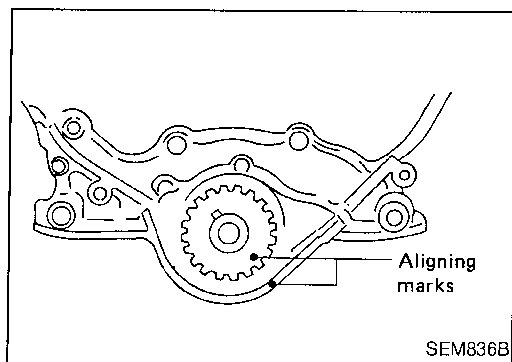

Installation

1. Set No. 1 piston at TDC on its compression stroke as follows:
 - a. Align crankshaft sprocket aligning mark with mark on oil pump body.
 - b. Confirm that knock pin on camshaft is set at the top.

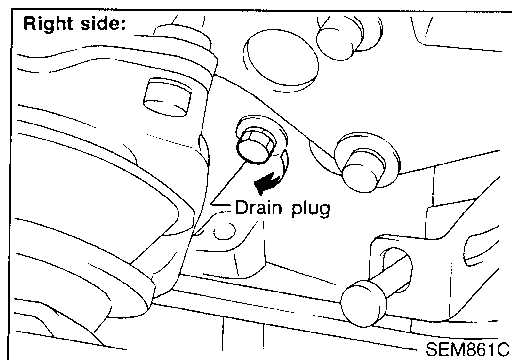

2. Install both drain plugs.
 - **Apply sealant to drain plug threads.**

CYLINDER BLOCK

Inspection (Cont'd)

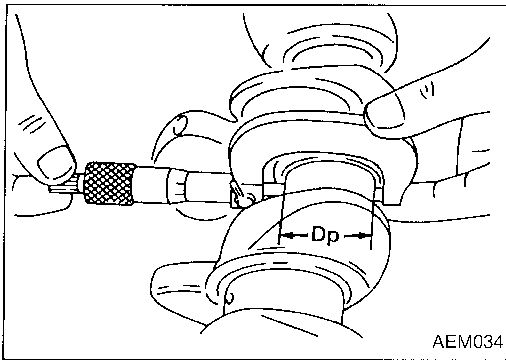

4. Measure outer diameter "Dp" of each crankshaft pin journal.
5. Calculate connecting rod bearing clearance.

Connecting rod bearing clearance (C - Dp):

Standard

0.014 - 0.054 mm (0.0006 - 0.0021 in)

Limit

0.090 mm (0.0035 in)

6. If it exceeds the limit, replace bearing.
7. If clearance cannot be adjusted within the standard of any bearing, grind crankshaft journal and use undersized bearing. Refer to step 7 of "BEARING CLEARANCE — Main bearing" (EM-41).

Method B (Using plastigage)

CAUTION:

- Do not turn crankshaft or connecting rod while plastigage is being inserted.
- When bearing clearance exceeds the specified limit, ensure that the proper bearing has been installed. Then if excessive bearing clearance exists, use a thicker main bearing or undersized bearing so that the specified bearing clearance is obtained.

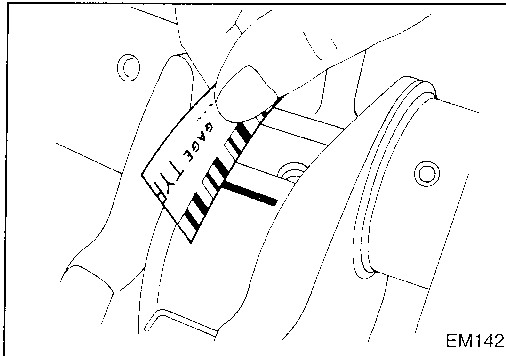

CONNECTING ROD BUSHING CLEARANCE (Small end)

1. Measure inner diameter "C" of bushing.
2. Measure outer diameter "Dp" of piston pin.
3. Calculate connecting rod bushing clearance.

Connecting rod bushing clearance = C - Dp

Standard: 0.005 - 0.017 mm (0.0002 - 0.0007 in)

Limit: 0.023 mm (0.0009 in)

If it exceeds the limit, replace connecting rod assembly or connecting rod bushing and/or piston set with pin.

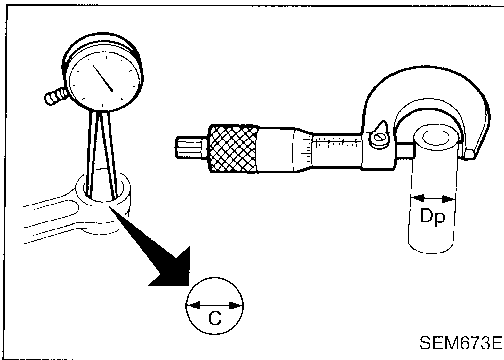

REPLACEMENT OF CONNECTING ROD BUSHING (Small end)

1. Drive in small end bushing until it is flush with end surface of rod.

Be sure to align the oil holes.

2. After driving in small end bushing, ream the bushing so that clearance between connecting rod bushing and piston pin is the specified value.

Clearance between connecting rod bushing and piston pin:

0.005 - 0.017 mm (0.0002 - 0.0007 in)

FLYWHEEL/DRIVE PLATE RUNOUT

Runout (Total indicator reading):

Flywheel (M/T model)

Less than 0.15 mm (0.0059 in)

Drive plate (A/T model)

Less than 0.15 mm (0.0059 in)

CAUTION:

- Be careful not to damage the ring gear teeth.
- Check the drive plate for deformation or cracks.
- Do not allow any magnetic materials to contact the ring gear teeth.
- Do not surface flywheel. Replace as necessary.

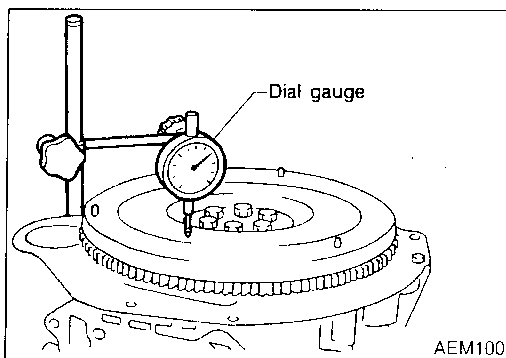
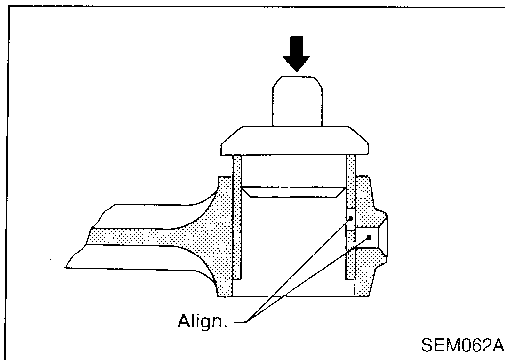

FRONT AXLE AND FRONT SUSPENSION

4WD model

SEC. 391•400•401

When installing rubber parts, final tightening must be carried out under unladen condition* with tires on ground.

* Fuel, radiator coolant and engine oil full.

Spare tire, jack, hand tools and mats in designated positions.

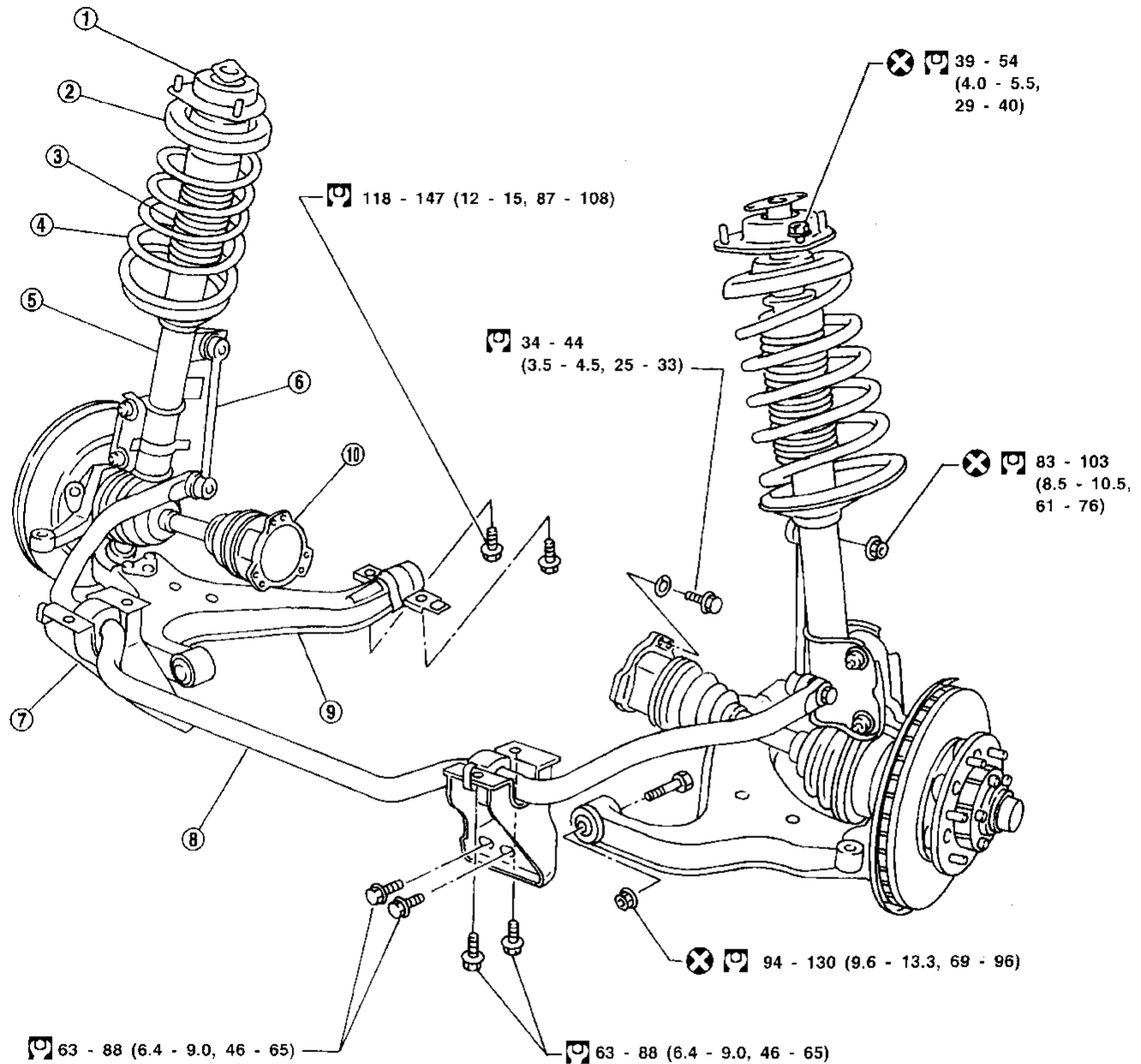

: N·m (kg-m, ft-lb)

- ① Strut mounting insulator
- ② Spring upper seat
- ③ Bound bumper
- ④ Coil spring

- ⑤ Strut assembly
- ⑥ Stabilizer connecting rod
- ⑦ Bracket

- ⑧ Stabilizer bar
- ⑨ Transverse link
- ⑩ Drive shaft

GI

MA

EM

LC

EC

FE

CL

MT

AT

TF

PD

FA

RA

BR

ST

RS

SFA744B

BT

HA

EL

IDX

FRONT AXLE (4WD)

Drive Shaft (Cont'd)

Wheel side (ZF100)

CAUTION:

The joint on the wheel side cannot be disassembled.

- Before separating joint assembly, put matching marks on drive shaft and joint assembly.
- Separate joint assembly with suitable tool.

Be careful not to damage threads on drive shaft.

- Remove boot bands.

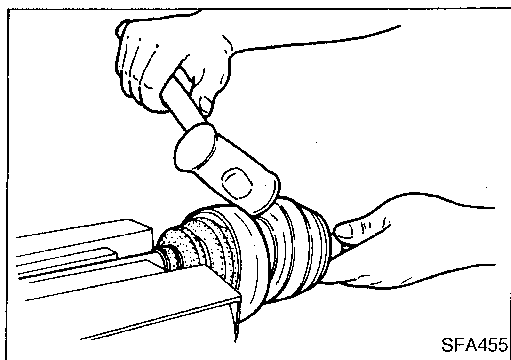

INSPECTION

Thoroughly clean all parts in cleaning solvent, and dry with compressed air. Check parts for evidence of deformation or other damage.

Drive shaft

Replace drive shaft if it is twisted or cracked.

Boot

Check boot for fatigue, cracks, or wear. Replace boot with new boot bands.

Joint assembly (Final drive side)

- Replace any parts of double offset joint which show signs of scorching, rust, wear or excessive play.
- Check serration for deformation. Replace if necessary.
- Check slide joint housing for any damage. Replace if necessary.

Joint assembly (Wheel side)

Replace joint assembly if it is deformed or damaged.

ASSEMBLY

- After drive shaft has been assembled, ensure that it moves smoothly over its entire range without binding.
- Use NISSAN GENUINE GREASE or equivalent after every overhaul.

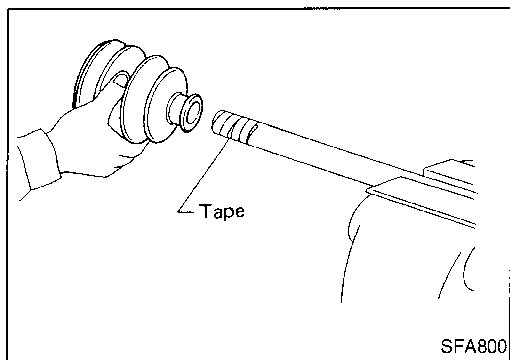

Final drive side (TS82F)

1. Install new small boot band, boot and side joint housing to drive shaft.

Cover drive shaft serration with tape so as not to damage boot during installation.

GI

MA

EM

LC

EC

FE

CL

MT

AT

TF

PD

FA

RA

BR

ST

RS

BT

HA

EL

IDX

ACCELERATOR CONTROL SYSTEM

Accelerator Control System

CAUTION:

- When removing accelerator wire, make a mark to indicate lock nut's initial position.
- Check that throttle valve opens fully when accelerator pedal is fully depressed. Also check that it returns to idle position when pedal is released.
- Check accelerator control parts for improper contact with any adjacent parts.
- When connecting accelerator wire, be careful not to twist or scratch its inner wire.
- Refer to EL section ("AUTOMATIC SPEED CONTROL DEVICE") for ASCD wire adjustment.

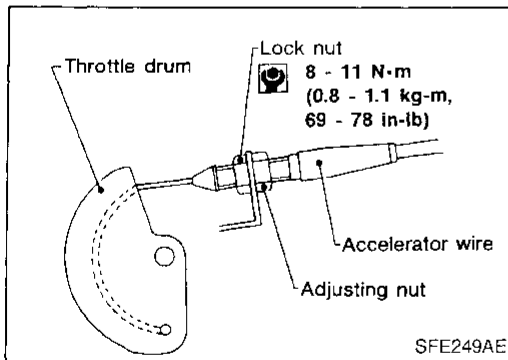
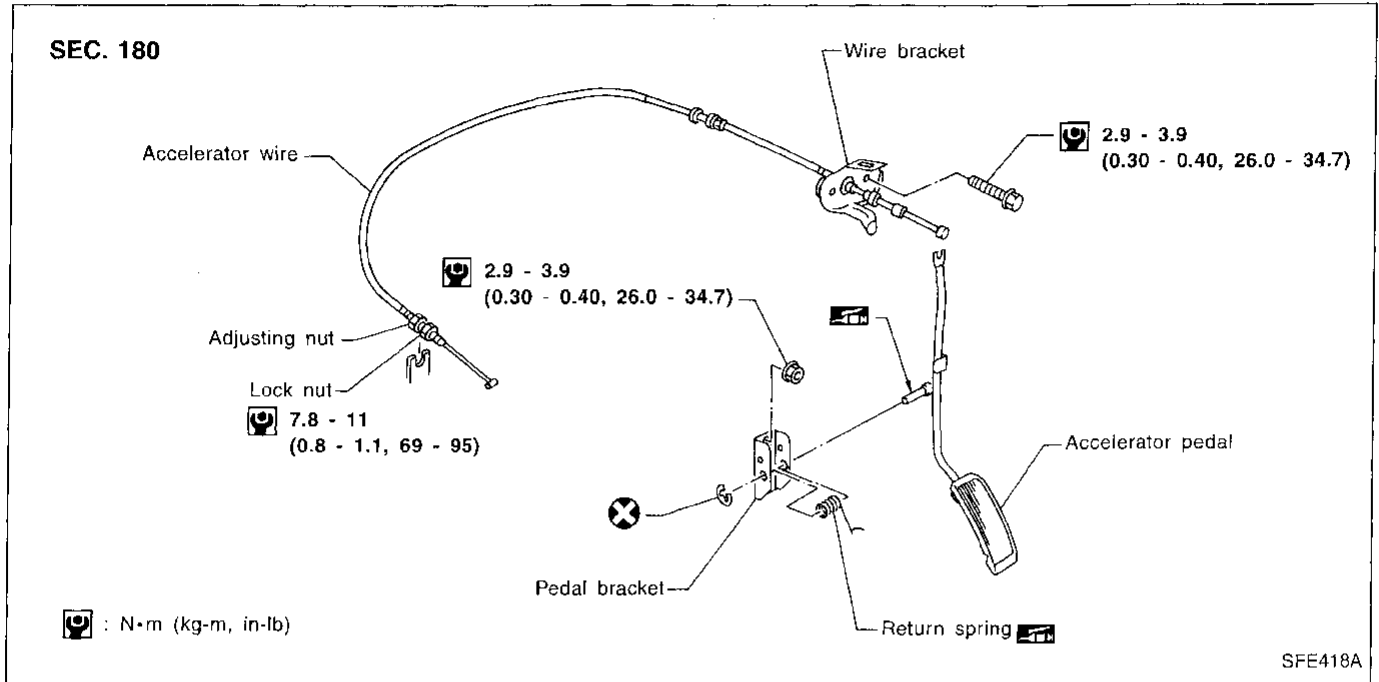

Adjusting Accelerator Wire

1. Loosen lock nut, and tighten adjusting nut until throttle drum starts to move.
2. From that position turn back adjusting nut 1.5 to 2 turns, and secure lock nut.

CI
MA
EM
LC
EC
FE
CL
MT
AT
TF
PD
FA
RA
BR
ST
RS
BT
HA
EL
DX

PRECAUTIONS

General Precautions (Cont'd)

WARNING:

To prevent ECM from storing the diagnostic trouble codes, do not carelessly disconnect the harness connectors which are related to the ECCS system and A/T control system. The connectors should be disconnected only when working according to the **WORK FLOW** of TROUBLE DIAGNOSES in EC and AT sections.

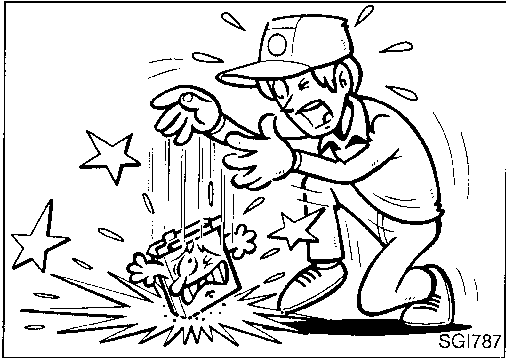

Precautions for Multiport Fuel Injection System or ECCS Engine

- Before connecting or disconnecting any harness connector for the multiport fuel injection system or ECM (ECCS control module):
 - Turn ignition switch to "OFF" position.
 - Disconnect negative battery terminal.
 - Otherwise, there may be damage to ECM.
- Before disconnecting pressurized fuel line from fuel pump to injectors, be sure to release fuel pressure.
- Be careful not to jar components such as ECM and mass air flow sensor.

Precautions for Three Way Catalyst

If a large amount of unburned fuel flows into the catalyst, the catalyst temperature will be excessively high. To prevent this, follow the instructions below:

- Use unleaded gasoline only. Leaded gasoline will seriously damage the three way catalyst.
- When checking for ignition spark or measuring engine compression, make tests quickly and only when necessary.
- Do not run engine when the fuel tank level is low, otherwise the engine may misfire causing damage to the catalyst.

Do not place the vehicle on flammable material. Keep flammable material off the exhaust pipe and the three way catalyst.

Precautions for Engine Oils

Prolonged and repeated contact with used engine oil may cause skin cancer. Try to avoid direct skin contact with used oil.

If skin contact is made, wash thoroughly with soap or hand cleaner as soon as possible.

HEALTH PROTECTION PRECAUTIONS

- Avoid prolonged and repeated contact with oils, particularly used engine oils.
- Wear protective clothing, including impervious gloves where practicable.
- Do not put oily rags in pockets.
- Avoid contaminating clothes, particularly underpants, with oil.
- Heavily soiled clothing and oil-impregnated footwear should not be worn. Overalls must be cleaned regularly.
- First Aid treatment should be obtained immediately for open cuts and wounds.
- Use barrier creams, applying them before each work period, to help the removal of oil from the skin.

HOW TO READ WIRING DIAGRAMS

Wiring Diagram Codes (Cell Codes) (Cont'd)

Code	Section	Wiring Diagram Name
START	EL	Starting System
STOP/L	EL	Stop Lamp
SW/V	EC	MAP/BARO Switch Solenoid Valve
TAIL/L	EL	Parking, License and Tail Lamps
TFTS	EC	Tank Fuel Temperature Sensor
THEFT	EL	Theft Warning System
TPS	EC	Throttle Position Sensor
TP/SW	EC	Throttle Position Switch
TRNSMT	EL	Integrated HOMELINK™ Transmitter

Code	Section	Wiring Diagram Name
TURN	EL	Turn Signal and Hazard Warning Lamps
VENT/V	EC	EVAP Canister Vent Control Valve
VSS	EC	Vehicle Speed Sensor
WARN	EL	Warning Lamps
WINDOW	EL	Power Window
WIPER	EL	Front Wiper and Washer
WIP/R	EL	Rear Wiper and Washer

HOW TO FOLLOW FLOW CHART IN TROUBLE DIAGNOSES

Key to symbols signifying measurements or procedures

Symbol	Symbol explanation	Symbol	Symbol explanation
	Check after disconnecting the connector to be measured.		Procedure with Generic Scan Tool (GST, OBD-II scan tool)
	Check after connecting the connector to be measured.		Procedure without CONSULT or GST
	Insert key into ignition switch.		A/C switch is "OFF".
	Remove key from ignition switch.		A/C switch is "ON".
	Turn ignition switch to "OFF" position.		REC switch is "ON".
	Turn ignition switch to "ON" position.		REC switch is "OFF".
	Turn ignition switch to "START" position.		Fan switch is "ON". (At any position except for "OFF" position)
	Turn ignition switch from "OFF" to "ACC" position.		Fan switch is "OFF".
	Turn ignition switch from "ACC" to "OFF" position.		Apply positive voltage from battery with fuse directly to components.
	Turn ignition switch from "OFF" to "ON" position.		Drive vehicle.
	Turn ignition switch from "ON" to "OFF" position.		Disconnect battery negative cable.
	Do not start engine, or check with engine stopped.		Depress brake pedal.
	Start engine, or check with engine running.		Release brake pedal.
	Apply parking brake.		Depress accelerator pedal.
	Release parking brake.		Release accelerator pedal.
	Check after engine is warmed up sufficiently.	<p>Pin terminal check for SMJ type ECM and A/T control unit connectors. For details regarding the terminal arrangement, refer to the foldout page.</p>	
	Voltage should be measured with a voltmeter.		
	Circuit resistance should be measured with an ohmmeter.		
	Current should be measured with an ammeter.		
	Procedure with CONSULT		
	Procedure without CONSULT		

SAE J1930 TERMINOLOGY LIST

SAE J1930 Terminology List (Cont'd)

***: Not applicable

NEW TERM	NEW ACRONYM / ABBREVIATION	OLD TERM
Manifold surface temperature	MST	***
Manifold surface temperature sensor	MSTS	***
Manifold vacuum zone	MVZ	***
Manifold vacuum zone sensor	MVZS	***
Mass air flow sensor	MAFS	Air flow meter
Mixture control solenoid valve	MC solenoid valve	Air-fuel ratio control solenoid valve
Multiport fuel injection System	MFI system	Fuel injection control
Neutral position switch	***	Neutral switch
Nonvolatile random access memory	NVRAM	***
On board diagnostic system	OBD system	Self-diagnosis
Open loop	OL	Open loop
Oxidation catalyst	OC	Catalyst
Oxidation catalytic converter system	OC system	***
Oxygen sensor	O2S	Exhaust gas sensor
Park position switch	***	Park switch
Park/neutral position switch	PNP switch	Park/neutral switch
Periodic trap oxidizer system	PTOX system	***
Positive crankcase ventilation	PCV	Positive crankcase ventilation
Positive crankcase ventilation valve	PCV valve	PCV valve
Powertrain control module	PCM	***
Programmable read only memory	PROM	***
Pulsed secondary air injection control solenoid valve	PAIRC solenoid valve	AIV control solenoid valve
Pulsed secondary air injection system	PAIR system	Air induction valve (AIV) control
Pulsed secondary air injection valve	PAIR valve	Air induction valve
Random access memory	RAM	***
Read only memory	ROM	***
Scan tool	ST	***
Secondary air injection pump	AIR pump	***
Secondary air injection system	AIR system	***
Sequential multiport fuel injection system	SFI system	Sequential fuel injection
Service reminder indicator	SRI	***
Simultaneous multiport fuel injection system	***	Simultaneous fuel injection
Smoke puff limiter system	SPL system	***
Supercharger	SC	***
Supercharger bypass	SCB	***
System readiness test	SRT	***
Thermal vacuum valve	TVV	Thermal vacuum valve
Three way catalyst	TWC	Catalyst
Three way catalytic converter system	TWC system	***
Three way + oxidation catalyst	TWC + OC	Catalyst

V-6 Variable Displacement Compressor

GENERAL INFORMATION

1. The V-6 variable compressor differs from previous units. The vent temperatures of the V-6 variable compressor do not drop too far below 5°C (41°F) when:
 - evaporator intake air temperature is less than 20°C (68°F)
 - engine is running at speeds less than 1,500 rpm.This is because the V-6 compressor provides a means of “capacity” control.
2. The V-6 variable compressor provides refrigerant control under varying conditions. During cold winters, it may not produce high refrigerant pressure discharge (compared to previous units) when used with air conditioning systems.
3. A “clanking” sound may occasionally be heard during refrigerant charge. The sound indicates that the tilt angle of the swash plate has changed and is not a problem.
4. For air conditioning systems with the V-6 compressor, the clutch remains engaged unless: the system main switch, fan switch or ignition switch is turned OFF. When ambient (outside) temperatures are low or when the amount of refrigerant is insufficient, the clutch is disengaged to protect the compressor.
5. A constant range of suction pressure is maintained when engine speed is greater than a certain value. It normally ranges from 147 to 177 kPa (1.5 to 1.8 kg/cm², 21 to 26 psi) under varying conditions. In previous compressors, however, suction pressure was reduced with increases in engine speed.

Preliminary Check

PRELIMINARY CHECK 1
A/C does not blow cold air.

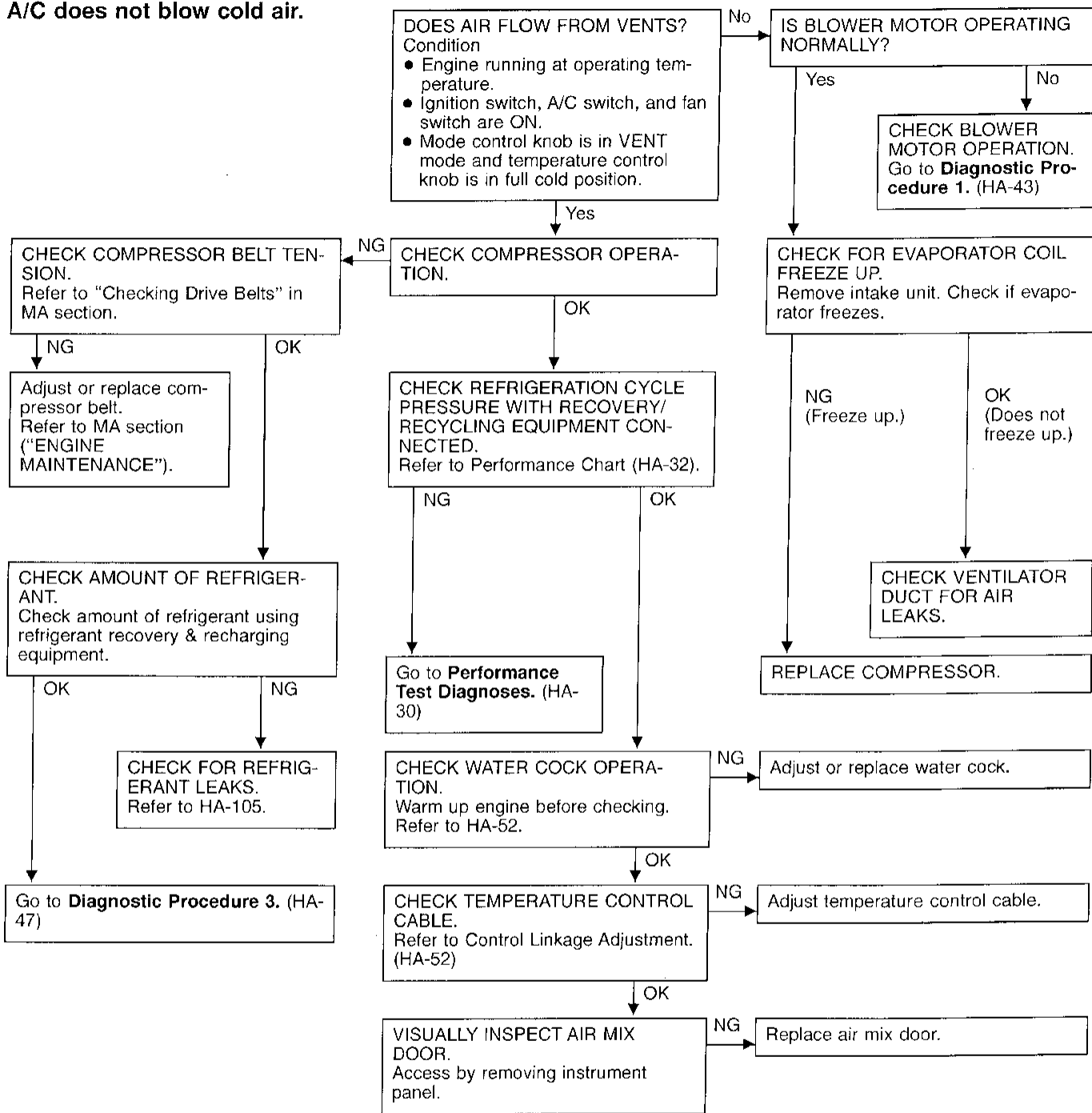

Wiring Diagram — A/C, M —

HA-A/C, M-01

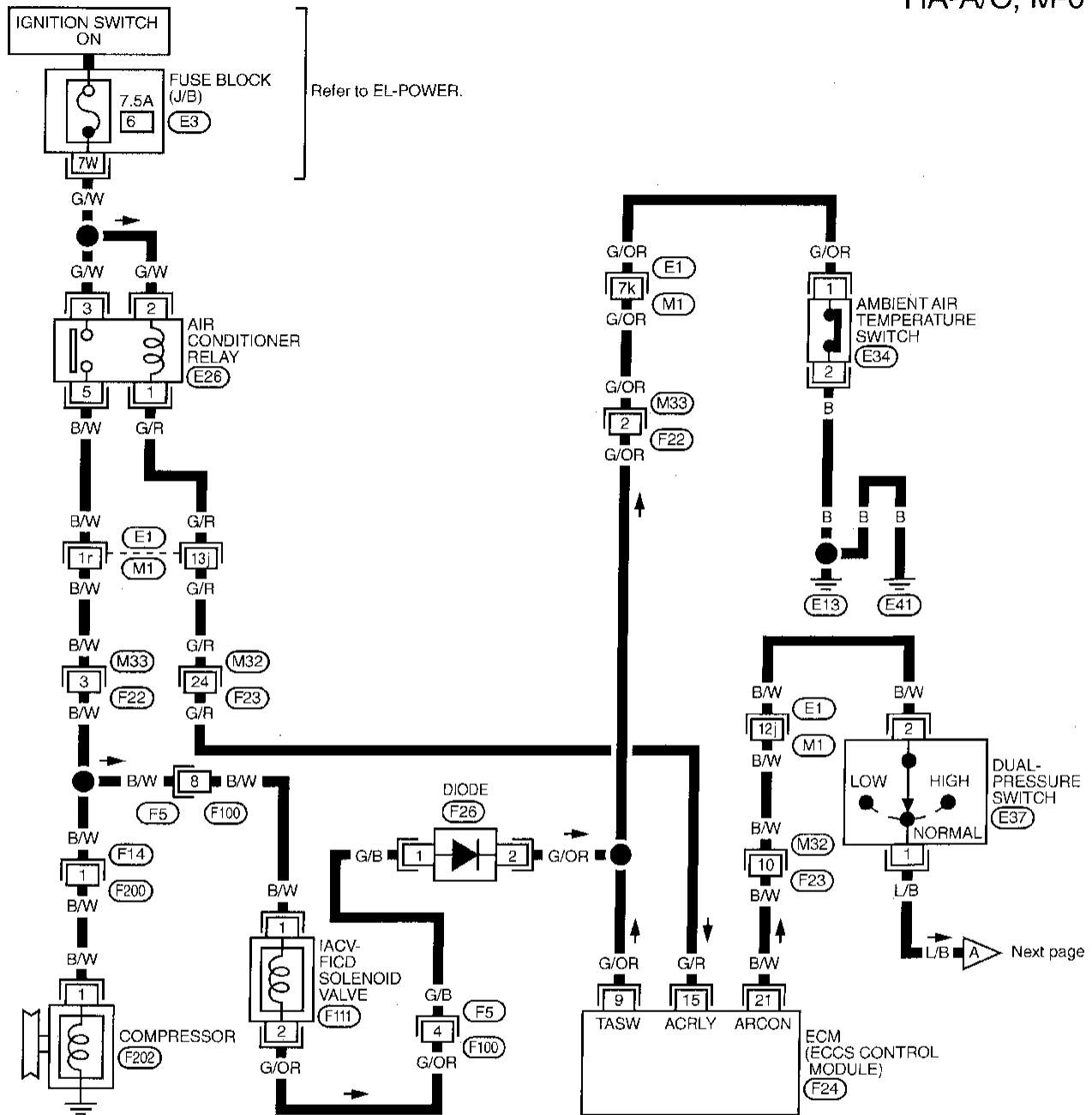

Refer to EL-POWER.

Next page

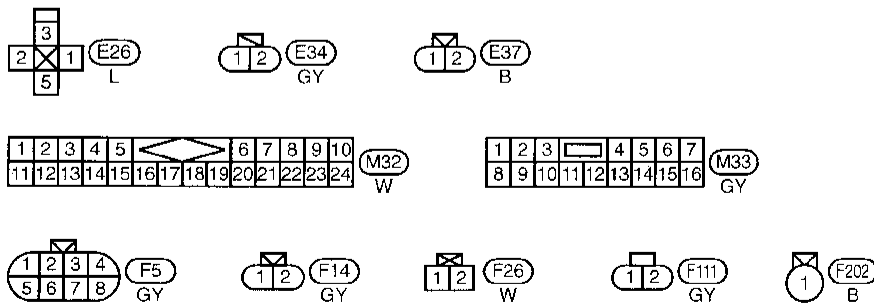

Refer to last page (Foldout page).



NOTE

Wiring Diagram — A/C, A —

HA-A/C, A-01

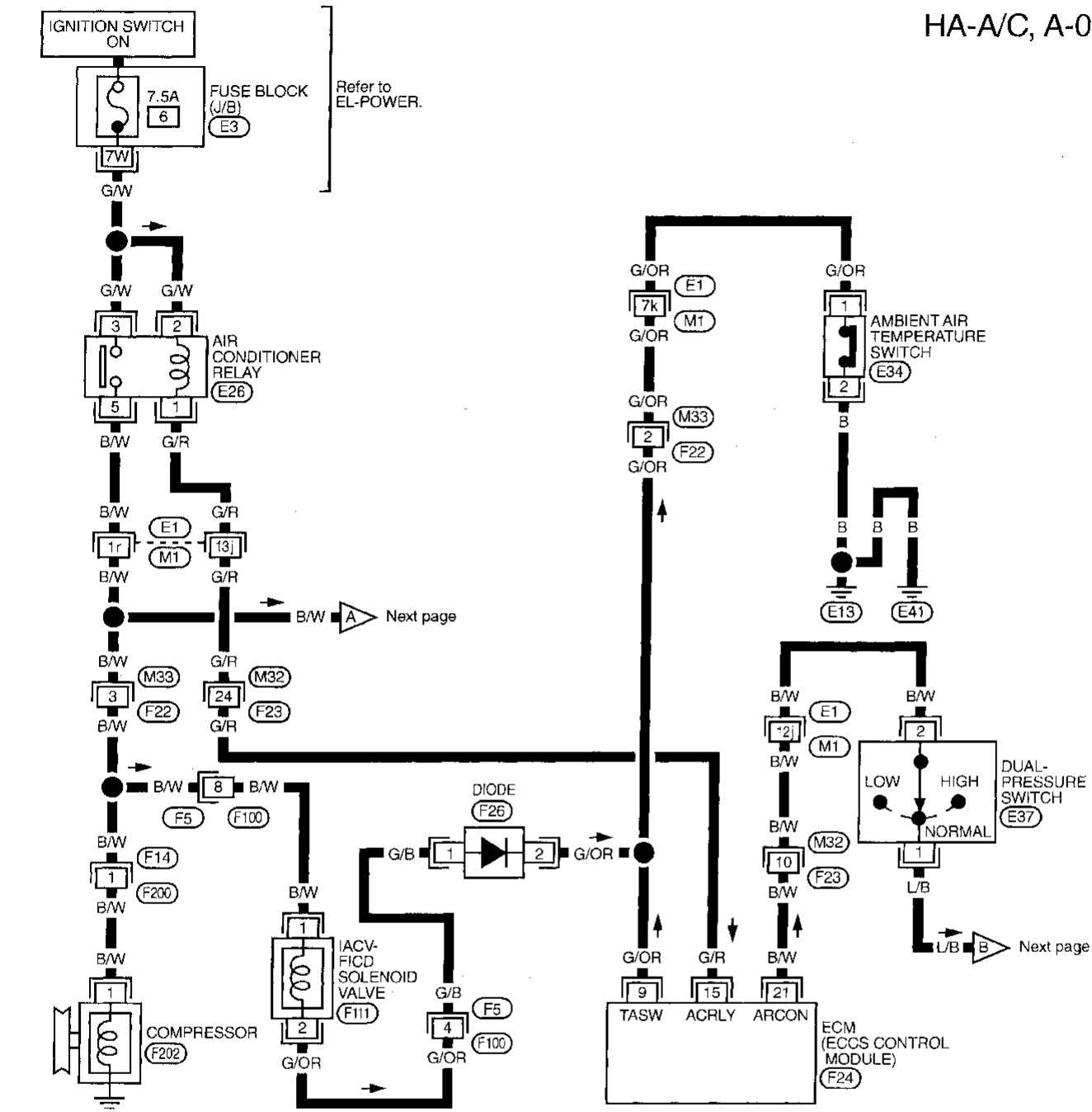

Refer to EL-POWER.

Next page

Next page

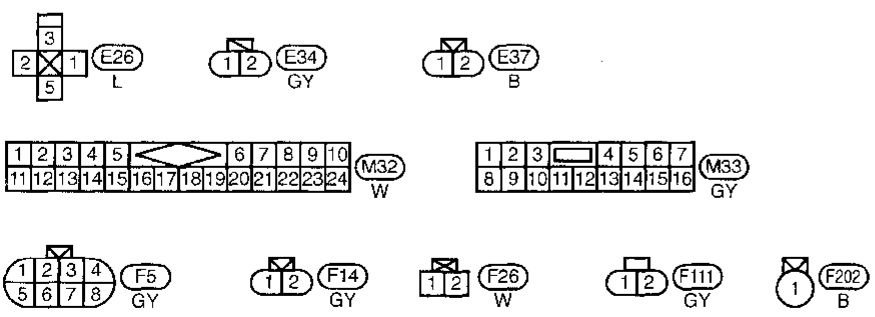

Refer to last page (Foldout page).



Diagnostic Procedure 6 (Cont'd)

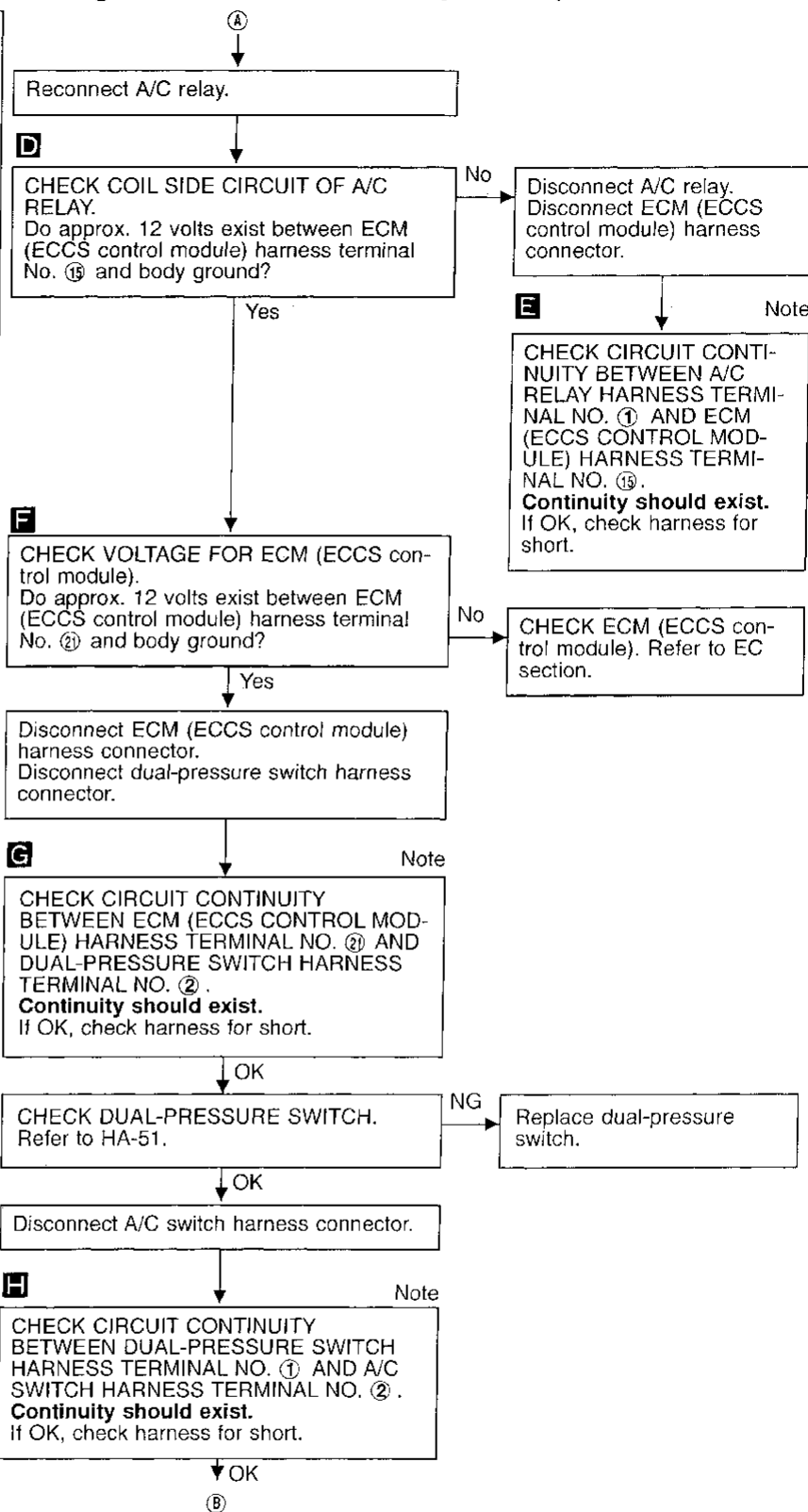
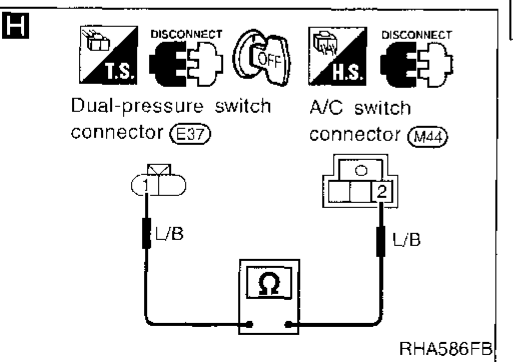
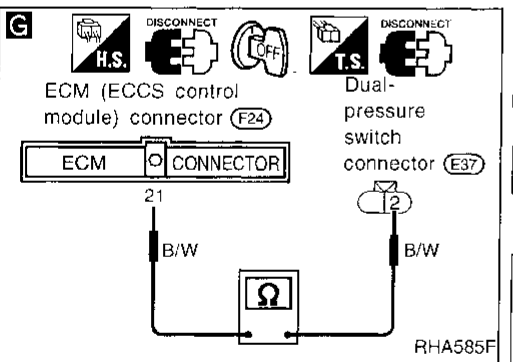
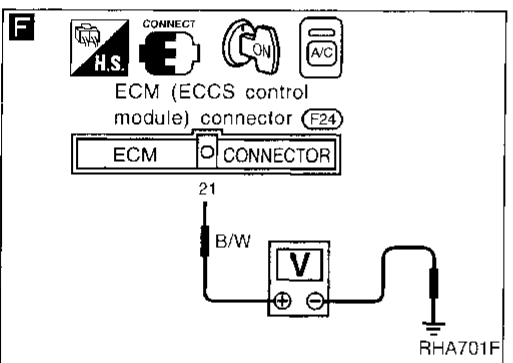
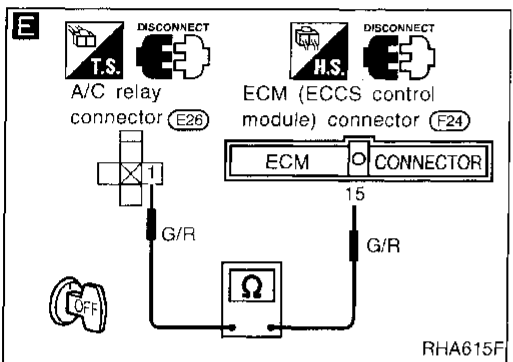
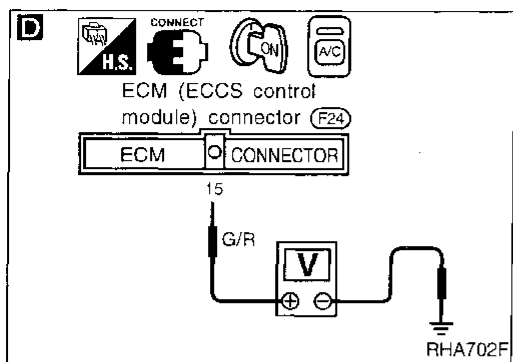

Note:
If the result is NG after checking circuit continuity, repair harness or connector.

Control System Output Components (Cont'd)
Air mix door control specification

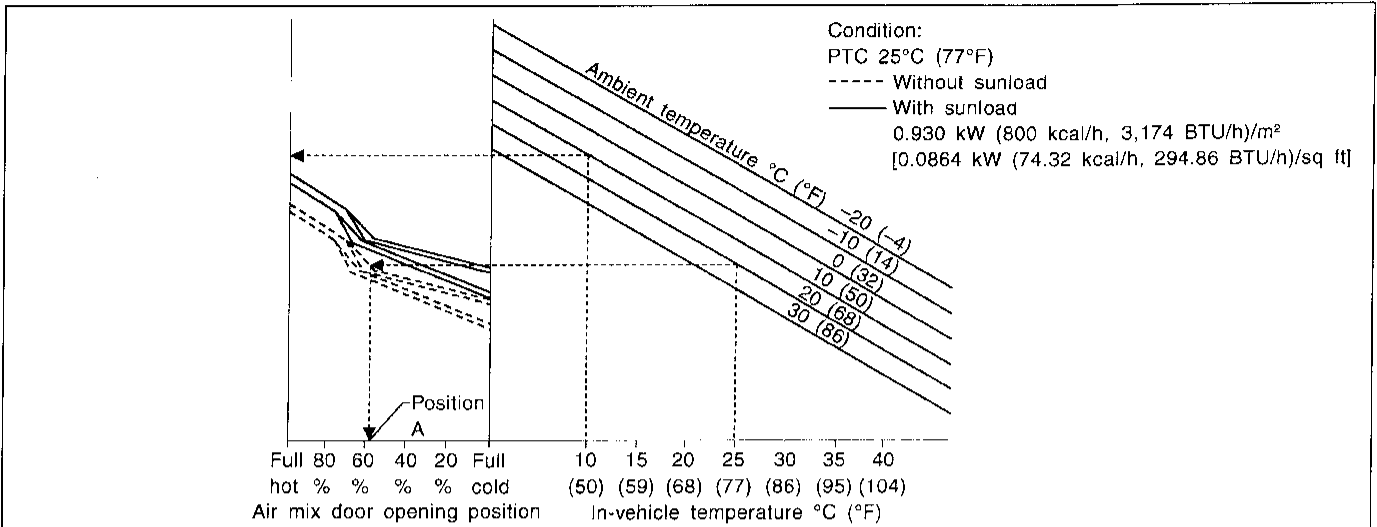

Example:

- If temperature setting is set at 25°C (77°F) under no sunload condition when ambient and in-vehicle temperature are 10°C (50°F), air mix door is initially automatically set in full hot position.
- Within some period, in-vehicle temperature will lower towards the objective temperature, and the air mix door position will shift gradually towards the cold side and finally stay in this position (A).

Air mix door opening position is always fed back to auto amp. by PBR built-in air mix door motor.

RHA707F

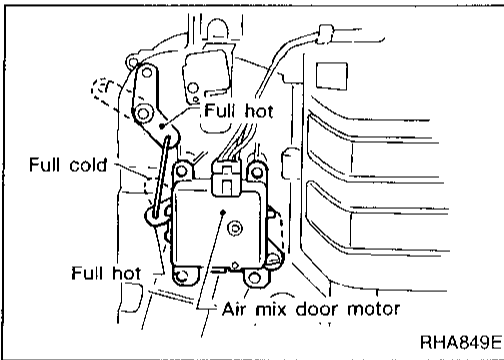

AIR MIX DOOR MOTOR

The air mix door motor is attached to the bottom of the heater unit. It rotates so that the air mix door is opened to a position set by the auto amp. Motor rotation is then conveyed through a shaft and air mix door position is then fed back to the auto amp. by PBR built-in air mix door motor.

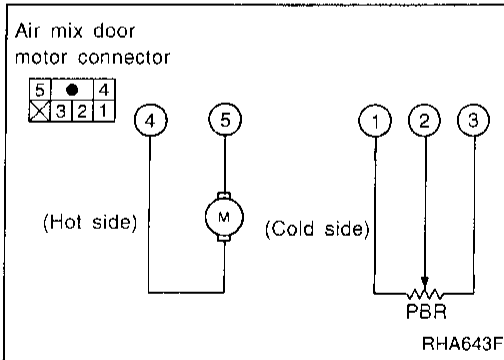

4	5	Air mix door operation	Direction of lever movement
⊕	⊖	COLD → HOT	Clockwise (Toward passenger compartment)
—	—	STOP	STOP
⊖	⊕	HOT → COLD	Counterclockwise (Toward engine compartment)

Compressor Clutch (Cont'd)

- Remove the snap ring using external snap ring pliers.

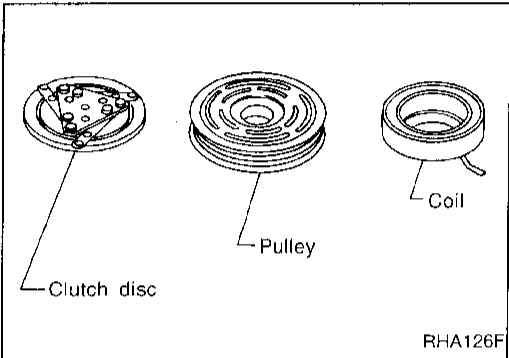
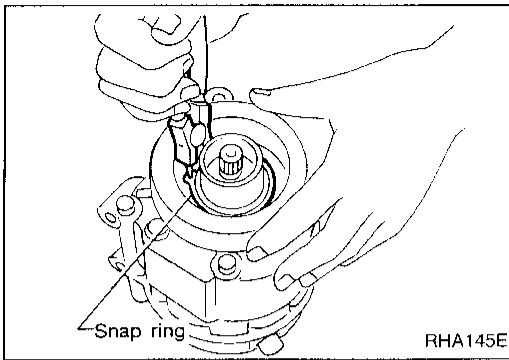

INSPECTION

Clutch disc

If the contact surface shows signs of damage due to excessive heat, replace clutch disc and pulley.

Pulley

Check the appearance of the pulley assembly. If the contact surface of pulley shows signs of excessive grooving, replace clutch disc and pulley. The contact surfaces of the pulley assembly should be cleaned with a suitable solvent before reinstallation.

Coil

Check coil for loose connection or cracked insulation.

INSTALLATION

- Install the field coil.

Be sure to align the coil's pin with the hole in the compressor's front head.

- Install the field coil harness clip using a screwdriver.

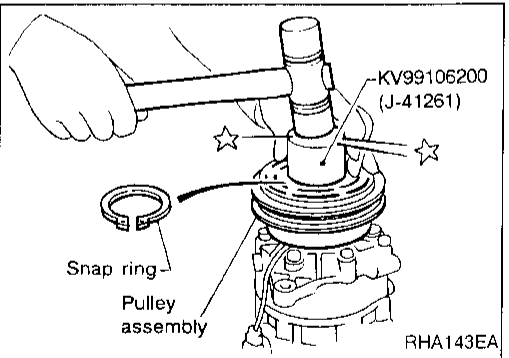
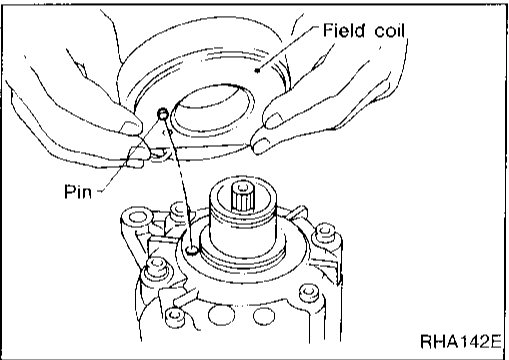

- Install the pulley assembly using the installer and a hand press, and then install the snap ring using snap ring pliers.

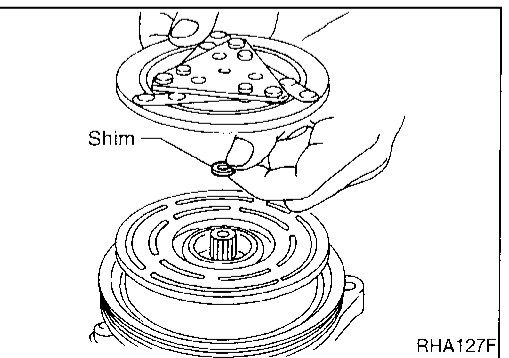

- Install the clutch disc on the drive shaft, together with the original shim(s). Press the clutch disc down by hand.

Lubrication Circuit

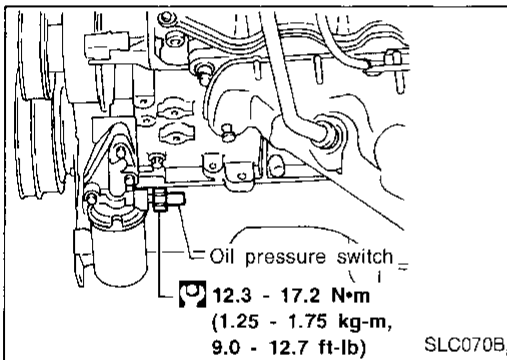
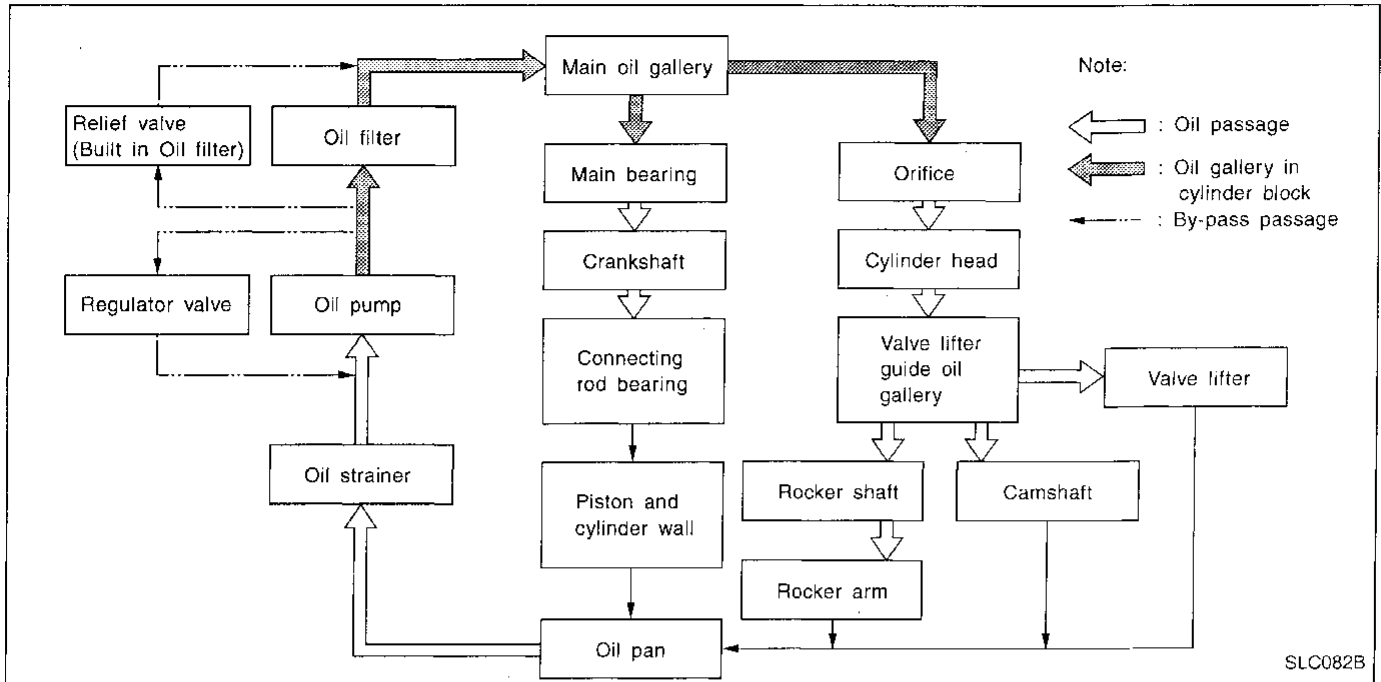

Oil Pressure Check

WARNING:

- Be careful not to burn yourself, as the engine and oil may be hot.
- Oil pressure check should be done in "Neutral position" (M/T) or "Parking position" (A/T).

1. Check oil level.
2. Remove oil pressure switch.

3. Install pressure gauge.
4. Start engine and warm it up to normal operating temperature.
5. Check oil pressure with engine running under no-load.

Engine speed rpm	Approximate discharge pressure kPa (kg/cm ² , psi)
Idle speed	More than 59 (0.6, 9)
2,000	412 - 451 (4.2 - 4.6, 60 - 65)

If difference is extreme, check oil passage and oil pump for oil leaks.

6. Install oil pressure switch with sealant.

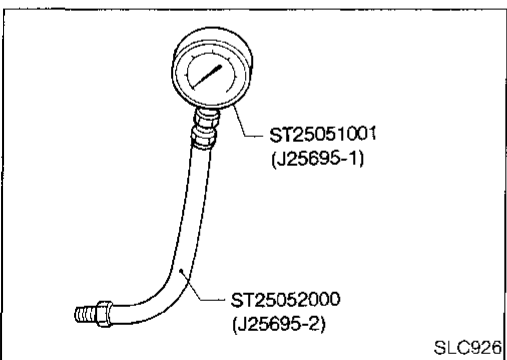

SERVICE DATA AND SPECIFICATIONS (SDS)

Engine Lubrication System

Oil pressure

Engine speed rpm	Approximate discharge pressure kPa (kg/cm ² , psi)
Idle speed	More than 59 (0.6, 9)
2,000	412 - 451 (4.2 - 4.6, 60 - 65)

Regulator valve

Unit: mm (in)	
Regulator valve to oil pump cover clearance	0.040 - 0.097 (0.0016 - 0.0038)

Oil pump

		Unit: mm (in)
Body to outer gear radial clearance	0.114 - 0.200 (0.0045 - 0.0079)	
Inner gear to outer gear tip clear- ance	Below 0.18 (0.0071)	
Body to inner gear axial clearance	0.05 - 0.09 (0.0020 - 0.0035)	
Body to outer gear axial clearance	0.050 - 0.110 (0.0020 - 0.0043)	
Inner gear to brazed portion of housing clearance	0.045 - 0.091 (0.0018 - 0.0036)	

Engine Cooling System

Thermostat

Valve opening temperature	°C (°F)	82 (180)
Valve lift	mm/°C (in/°F)	More than 10/95 (0.39/203)

Radiator

Unit: kPa (kg/cm ² , psi)		
Cap relief pressure	Standard	78 - 98 (0.8 - 1.0, 11 - 14)
	Limit	59 - 98 (0.6 - 1.0, 9 - 14)
Leakage test pressure		157 (1.6, 23)

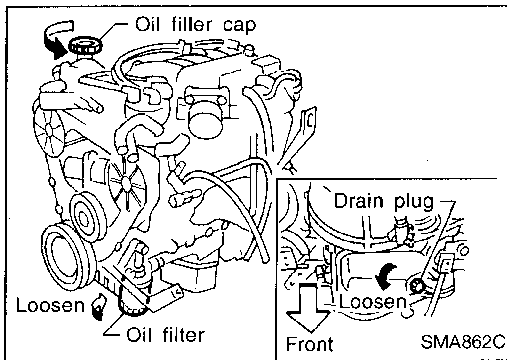

Changing Engine Oil

WARNING:

- Be careful not to burn yourself, as the engine oil is hot.
- Prolonged and repeated contact with used engine oil may cause skin cancer; try to avoid direct skin contact with used oil. If skin contact is made, wash thoroughly with soap or hand cleaner as soon as possible.

1. Warm up engine, and check for oil leakage from engine components.
2. Stop engine and wait for more than 10 minutes.
3. Remove drain plug and oil filler cap.
4. Drain oil and refill with new engine oil.

Oil specification and viscosity

- API SG or SH and Energy Conserving II
- API Certification Mark
- See "RECOMMENDED FLUIDS AND LUBRICANTS", MA-8.

Refill oil capacity (Approximately) :

Unit: *l* (US qt, Imp qt)

With oil filter change	3.7 (3-7/8, 3-1/4)
Without oil filter change	3.4 (3-5/8, 3)

CAUTION:

- Be sure to clean drain plug and install with new washer.
Oil pan drain plug:
Ⓜ: 29 - 39 N·m
(3.0 - 4.0 kg·m, 22 - 29 ft·lb)
- The refill capacity depends on the oil temperature and drain time; use the "Refill oil capacity" values as a reference and be certain to check with the dipstick when changing the oil.

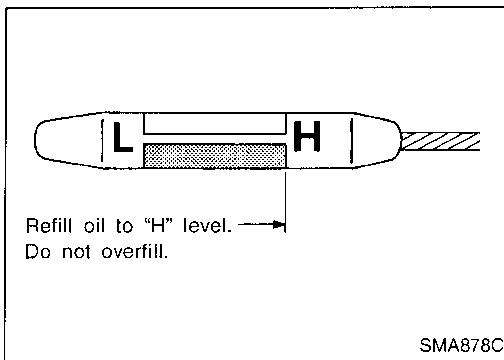

5. Warm up engine and check area around drain plug and oil filter for oil leakage.
6. Stop engine and wait for more than 10 minutes.
7. Check oil level.

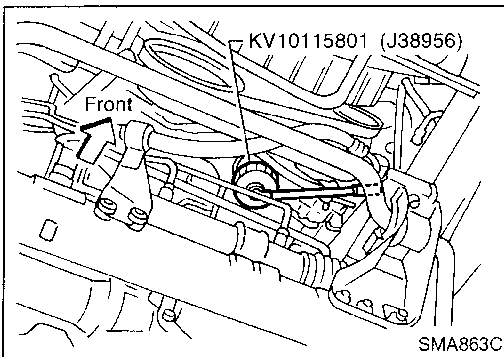

Changing Oil Filter

1. Remove oil filter with Tool.

WARNING:

Be careful not to burn yourself, as the engine and engine oil are hot.

The filter is a full-flow cartridge type and is provided with a relief valve.

Refer to LC section ("Oil Filter", "ENGINE LUBRICATION SYSTEM").

PREPARATION

Special Service Tools (Cont'd)

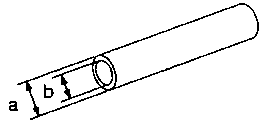
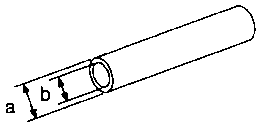
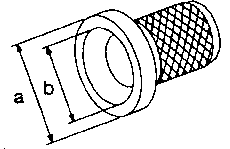
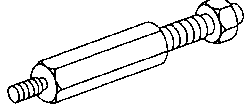
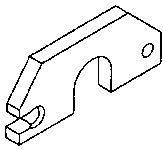
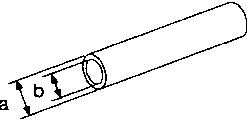
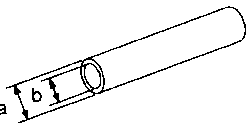
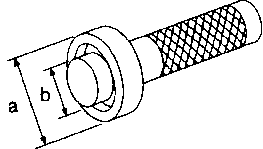
Tool number (Kent-Moore No.) Tool name	Description	
ST37750000 ① (J34286) ② (J34332) ③ (J34334) ④ (J25679-01) Drift		① Removing counter gear rear bearing ② Installing OD gear bushing ② Removing and installing mainshaft rear bearing (4WD model) ② Installing reverse cone ③ Installing reverse counter gear ④ Installing counter gear rear end bearing a: 40 mm (1.57 in) dia. b: 31 mm (1.22 in) dia.
NT065		CI
ST22452000 (J34337) Drift		Installing reverse hub Installing mainshaft rear bearing (2WD model) a: 45 mm (1.77 in) dia. b: 36 mm (1.42 in) dia.
NT065		MA
ST33400001 (J26082) Drift		Installing rear oil seal a: 60 mm (2.36 in) dia. b: 47 mm (1.85 in) dia.
NT086		EM
(J26349-3) Puller leg		Installing mainshaft and counter gear (Use with J34328)
NT078		LC
(J34328) Puller		Installing mainshaft and counter gear (Use with J26349-3)
NT079		EC
(J26092) Drift		Installing sub-gear snap ring a: 44.5 mm (1.752 in) dia. b: 38.5 mm (1.516 in) dia.
NT065		FE
(J34342) Drift		Installing OD main gear Installing reverse gear bushing a: 44.5 mm (1.752 in) dia. b: 40.5 mm (1.594 in) dia.
NT065		CL
ST33220000 (J25804-01) Drift		Installing mainshaft rear bearing a: 37 mm (1.46 in) dia. b: 22 mm (0.87 in) dia.
NT084		MT

Commercial Service Tool

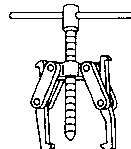
Tool name	Description	
Puller		Removing counter gear rear end bearing Removing mainshaft rear bearing (2WD model) Removing reverse synchronizer hub Removing reverse counter gear
NT077		EA

DISASSEMBLY

Shift Control Components (Cont'd)

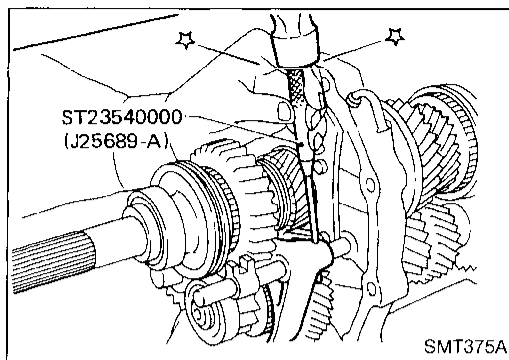

5. Drive out retaining pin from OD shift fork.
6. Pull out OD fork rod and then remove OD shift fork.

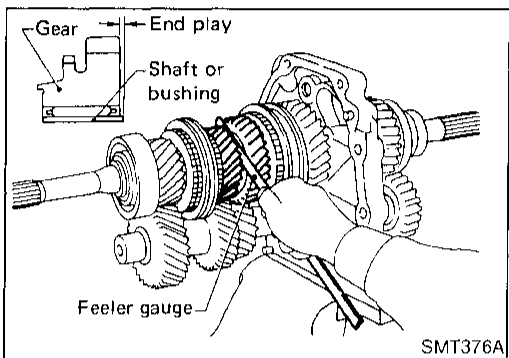

Gear Components

1. Before removing gears and shafts, measure each gear end play.

Gear end play:

Refer to SDS, MT-35.

- If not within specification, disassemble and check contact surface of gear to hub, washer, bushing, needle bearing and shaft.

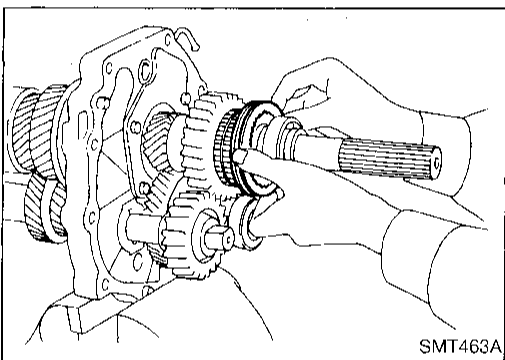

2. Remove rear side components on mainshaft and counter gear.
 - a. Remove reverse coupling sleeve.

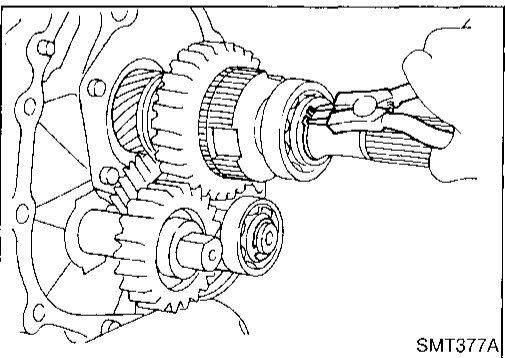

- b. Remove mainshaft rear snap ring and counter gear rear snap ring.
- c. Remove C-ring holder and mainshaft C-rings from mainshaft. Use punch and hammer to remove C-rings.

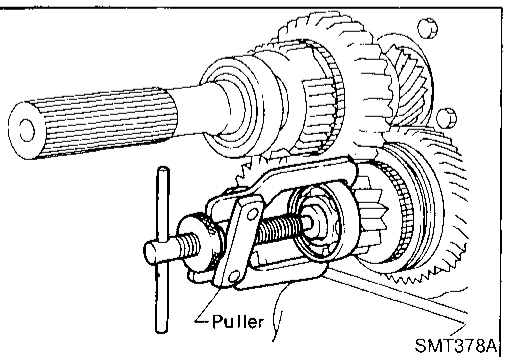

- d. Pull out counter gear rear end bearing.
- e. Remove reverse idler gear and reverse idler thrust washers.

GI

MA

EM

LC

EC

FE

CL

MT

AT

TF

PD

FA

RA

BR

ST

RS

BT

HA

EL

IDX

ASSEMBLY

Gear Components (Cont'd)

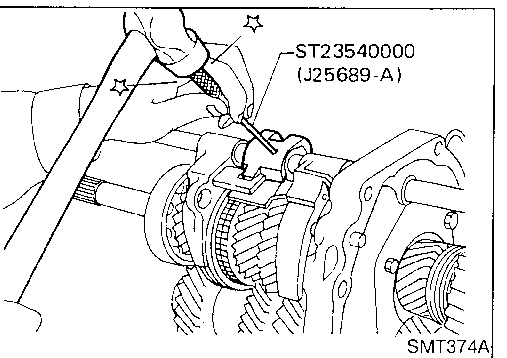
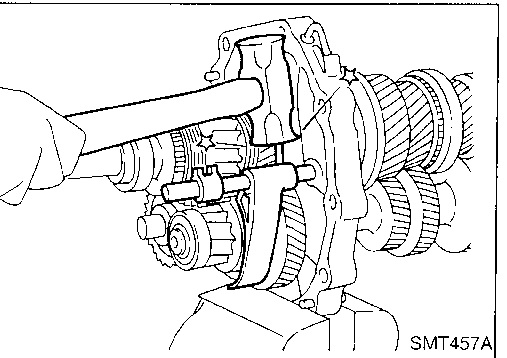
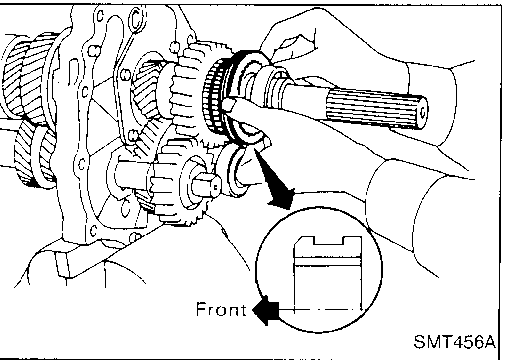
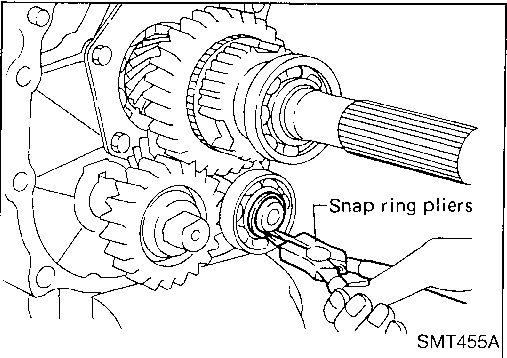
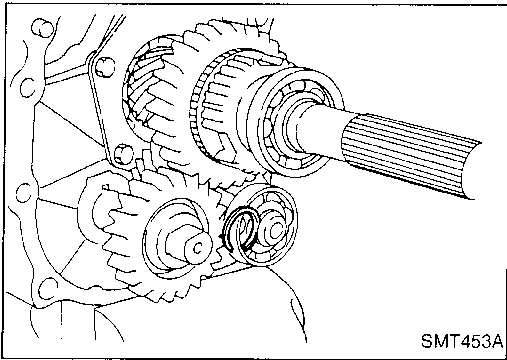

- p. Select proper counter gear rear snap ring to minimize clearance of groove.
Allowable clearance of groove:
0 - 0.1 mm (0 - 0.004 in)
Counter gear rear snap ring:
Refer to SDS, MT-36.
- q. Install selected counter gear rear snap ring.

- r. Install reverse coupling sleeve.
 ● **Pay attention to its direction.**
- s. Measure each gear end play as a final check. Refer to "DISASSEMBLY", MT-17.

Shift Control Components

1. Install OD fork rod and OD shift fork. Then install retaining pin into OD shift fork.
2. Install 1st & 2nd, 3rd & 4th and reverse shift fork onto coupling sleeve.

3. Install striking rod into hole of shift forks, striking lever and interlock and then install retaining pin into striking lever.
 ● **Make sure that striking rod moves smoothly.**

GI
 MA
 EM
 LC
 EC
 FE
 CL
MT
 AT
 TF
 PD
 FA
 RA
 BR
 ST
 RS
 ST
 HA
 EL
 ICX

PROPELLER SHAFT

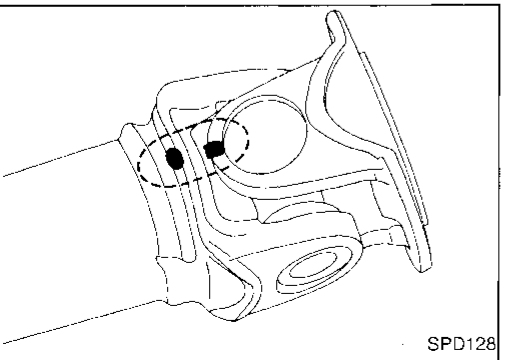
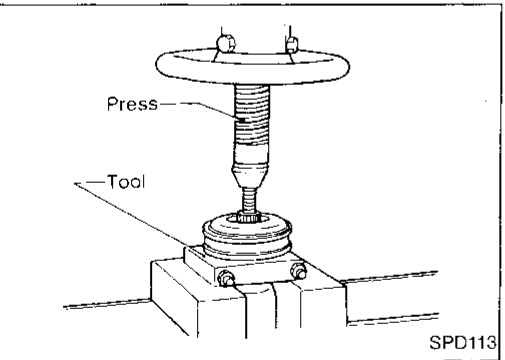
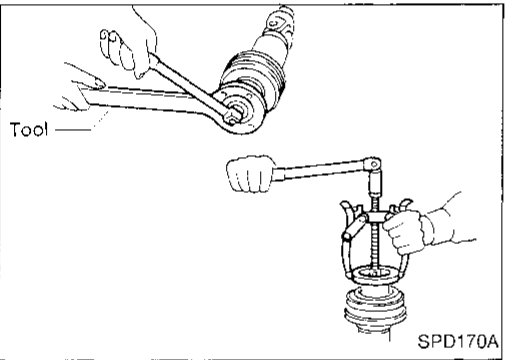
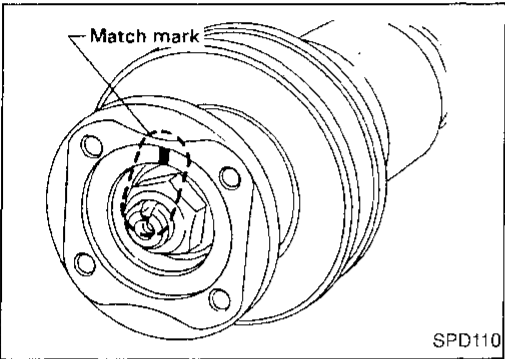
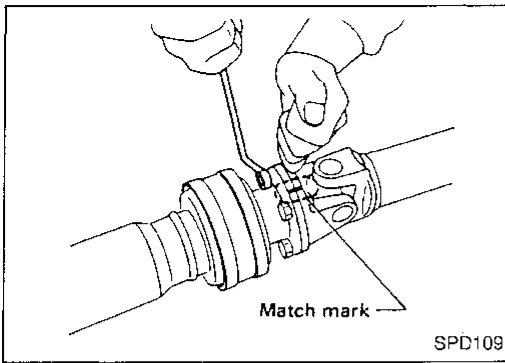

Disassembly

CENTER BEARING — 2WD —

1. Put match marks on flanges, and separate 2nd tube from 1st tube.
2. Put match marks on the flange and shaft.
3. Remove locking nut with Tool.
Tool number:
ST38060002 (J34311)
4. Remove companion flange with puller.
5. Remove center bearing with Tool and press.
Tool number: ST30031000 (J22912-01)

JOURNAL (71H and 80B)

1. Put match marks on shaft and flange or yoke.

GI

MA

EM

LC

EC

FE

CL

MT

AT

FP

PD

FA

RA

BR

ST

RS

BT

HA

EL

IDX

ADJUSTMENT

Side Bearing Preload (Cont'd)

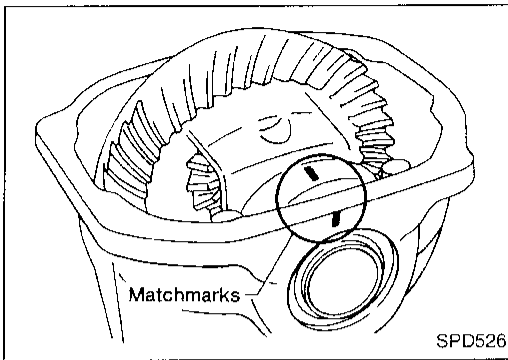

5. Install the side bearing caps in their correct locations and torque the bearing cap retaining bolts.

Specification:

88 - 98 N·m (9 - 10 kg·m, 65 - 72 ft·lb)

6. Turn the carrier several times to seat the bearings.

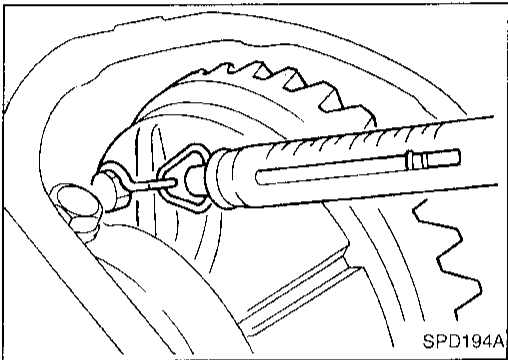

7. Measure the turning torque of the carrier at the ring gear retaining bolts with a spring gauge, J8129.

Specification:

34.3 - 39.2 N (3.5 - 4.0 kg, 7.7 - 8.8 lb) of pulling force at the ring gear bolt.

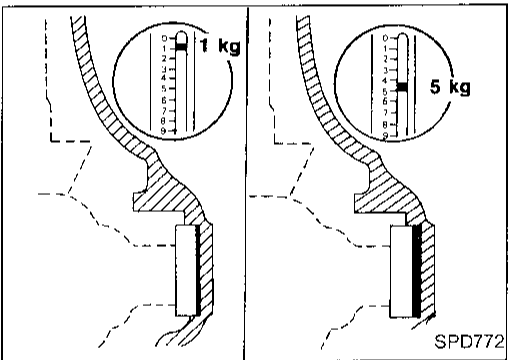

8. If the carrier turning torque is not within the specification range, increase or decrease the total thickness of the side bearing adjusting washers until the turning torque is correct. If the turning torque is less than the specified range, install washers of greater thickness; if the turning torque is greater than the specification, install thinner washers. See the SDS section for washer dimensions and part numbers.

9. Record the total amount of washer thickness required for the correct carrier side bearing preload.

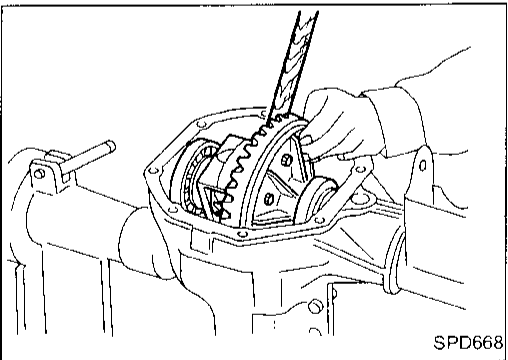

10. Remove the carrier from the final drive housing, saving the selected preload washers for later use during the assembly of the final drive unit.

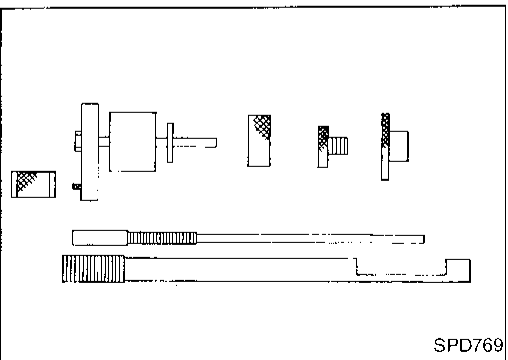

Pinion Gear Height and Pinion Bearing Preload

1. Make sure all parts are clean and that the bearings are well lubricated.
2. Assemble the pinion gear bearings into the pinion pre-load shim selector Tool, J34309.

GI
MA
EM
LC
EC
FE
CL
MT
AT
TF
PD
FA
RA
BR
ST
RS
BT
HA
EL
IDX

Differential Carrier (Cont'd)

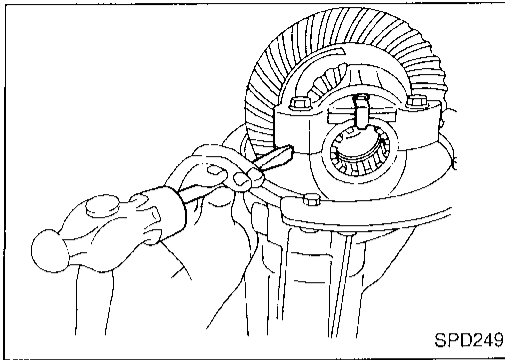

- Put match marks on one side of side bearing cap with paint or punch to ensure that it is replaced in proper position during reassembly.

Bearing caps are line-bored during manufacture and should be put back in their original places.

GI

MA

EM

LC

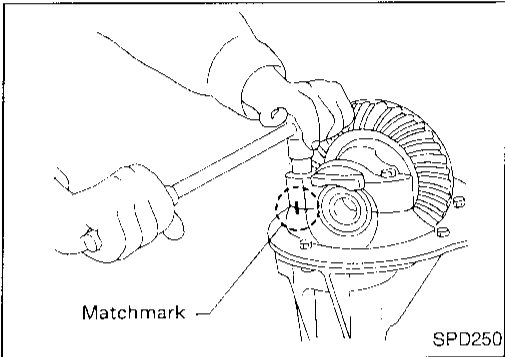

- Remove side lock fingers and side bearing caps.

EC

FE

CL

MT

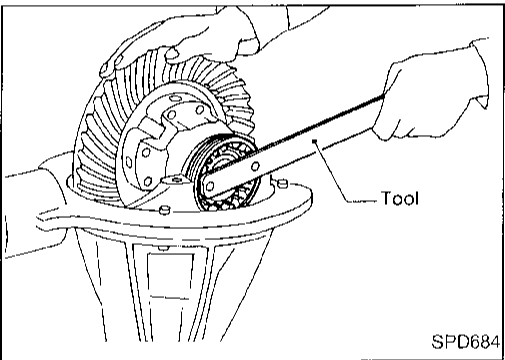

- Remove side bearing adjuster with Tool.
Tool number: ST32580000 (J34312)

AT

TF

PD

EA

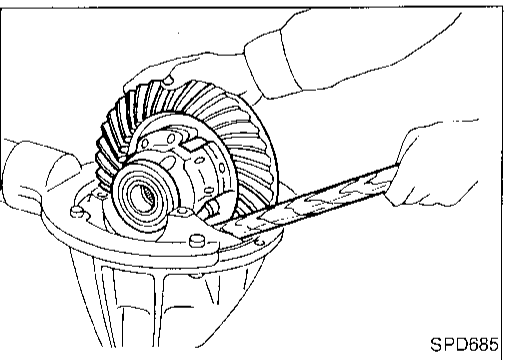

- Remove differential case assembly with a pry bar.

RA

BR

ST

RS

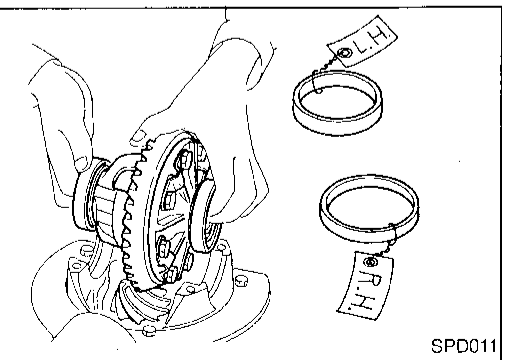

Be careful to keep the side bearing outer races together with their respective inner cones — do not mix them up.

BT

HA

EL

IDX

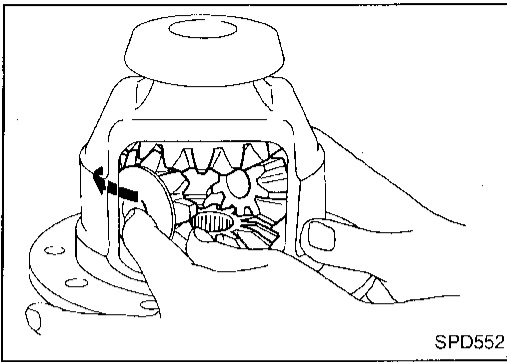

Differential Case

1. Install side gears, pinion mate gears and thrust washers into differential case.

GI

MA

EM

LC

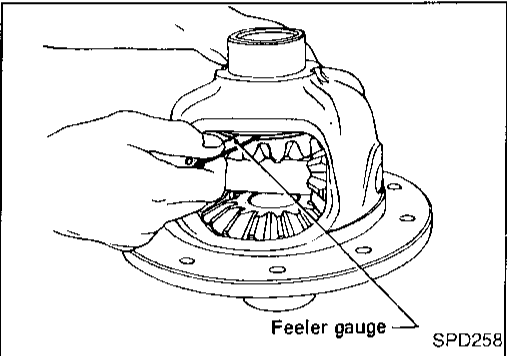

2. Fit pinion mate shaft to differential case so that it meets lock pin holes.
3. Adjust backlash between side gear and pinion mate gear by selecting side gear thrust washer.

EC

FE

**Backlash between side gear and pinion mate gear
(Clearance between side gear thrust washer and differential case):**

0.10 - 0.20 mm (0.0039 - 0.0079 in)

CL

MT

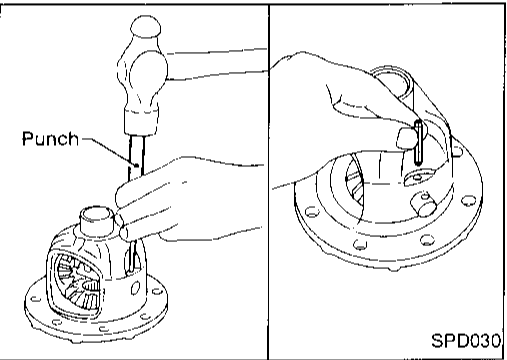

4. Install pinion mate shaft lock pin with a punch.
Make sure lock pin is flush with case.

AT

TF

PD

FA

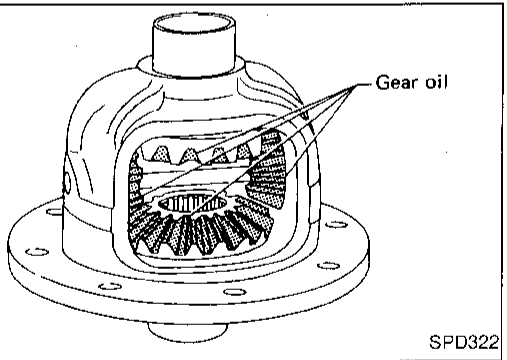

5. Apply gear oil to gear tooth surfaces and thrust surfaces and check to see they turn properly.
6. Install differential case assembly on ring gear.

RA

Tighten bolts in a criss-cross pattern, lightly tapping bolt head with a hammer.

BR

ST

RS

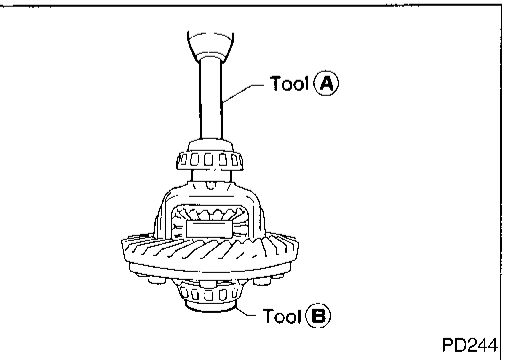

7. Press-fit side bearing inner cones on differential case with Tool.

BT

Tool number:

- (A) ST33190000 (J25523)
- (B) ST33081000 (—)

HA

EL

IDX

REAR AXLE

Removal (Cont'd)



4. Remove oil seal with a screwdriver.
Do not reuse oil seal once it is removed. Always install new one.
5. Remove ABS sensor rotor.

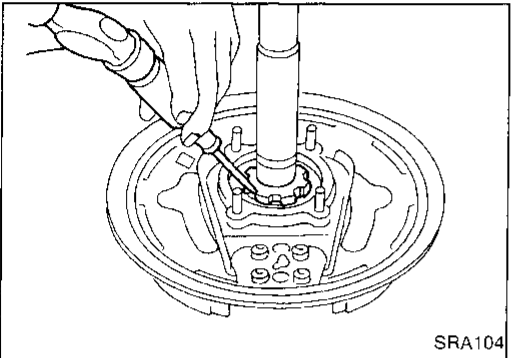

6. Unbend lock washer with a screwdriver.
Do not reuse lock washer once removed. Always install new one.

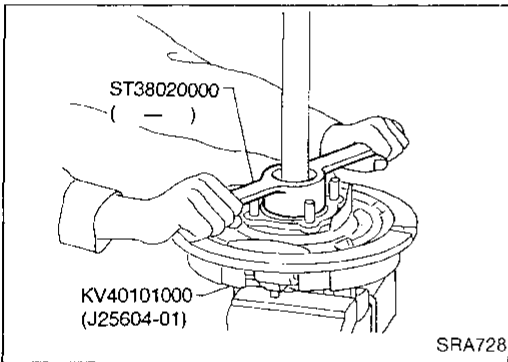

7. Remove bearing lock nut with Tool.

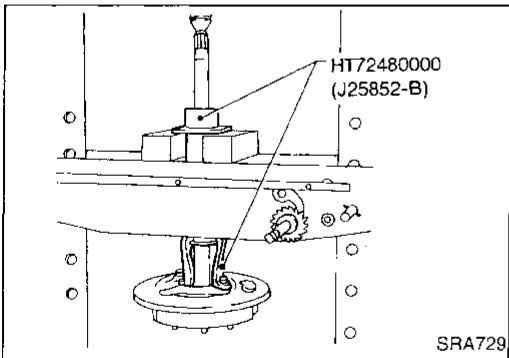

8. Remove wheel bearing together with bearing cage and baffle plate from axle shaft.

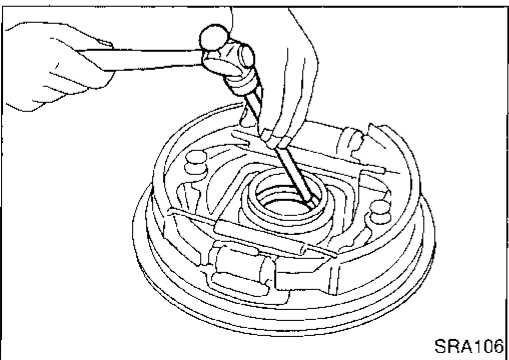

9. Remove grease seal with a screwdriver.
10. Remove wheel bearing assembly with a brass drift.

GI

MA

EM

LC

EC

FE

CL

MT

AT

TF

PD

FA

RA

BR

ST

RS

BT

HA

EL

IDX

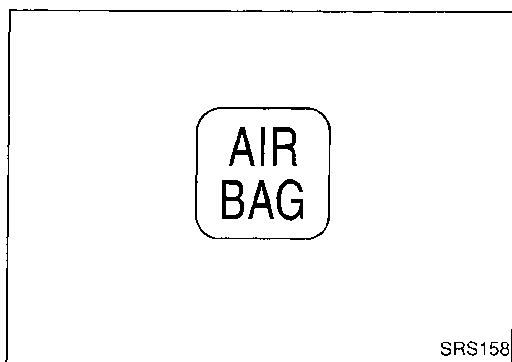

Maintenance Items

1. Check "AIR BAG" warning lamp operation
 - After turning ignition key to "ON" position, "AIR BAG" warning lamp illuminates. The "AIR BAG" warning lamp will turn off after about 7 seconds if no malfunction is detected. If any of the following air bag warning lamp conditions occur, immediately check the air bag system. Refer to RS-22 for details.
 - The warning lamp does not illuminate when the ignition switch is turned "ON".
 - The warning lamp does not turn off about 7 seconds after the ignition switch is turned "ON".
 - The warning lamp blinks about 7 seconds after the ignition switch is turned "ON".

2. Visually check SRS components
 - (1) Diagnosis sensor unit
 - Check diagnosis sensor unit and bracket for dents, cracks or deformities.
 - Check connectors for damage, and terminals for deformities.

 - (2) Air bag module and steering wheel
 - Remove air bag module from steering wheel or instrument panel. Check harness cover and connectors for damage, terminals for deformities, and harness for binding.
 - Install driver side air bag module to steering wheel to check fit or alignment with the wheel.
 - Check steering wheel for excessive free play.
 - Install passenger side air bag module to instrument panel to check fit or alignment with the instrument panel.

 - (3) Spiral cable
 - Check spiral cable for dents, cracks, or deformities.
 - Check connectors and protective tape for damage.
 - Check steering wheel for noise, binding or heavy operation.

 - (4) Main harness and air bag harness
 - Check connectors for poor connections, damage, and terminals for deformities.
 - Check harnesses for binding, chafing or cut.

CAUTION:

Replace previously used special bolts and ground bolt with new ones.

GI

MA

EM

LC

EC

FE

CL

MT

AT

TF

PD

FA

RA

BR

ST

RS

BT

HA

EL

IDX

CLICK HERE TO **DOWNLOAD** THE COMPLETE MANUAL

- Thank you very much for reading the preview of the manual.
- You can download the complete manual from: www.heydownloads.com by clicking the link below



- Please note: If there is no response to CLICKING the link, please download this PDF first and then click on it.

CLICK HERE TO **DOWNLOAD** THE COMPLETE MANUAL