

# NISSAN SENTRA

MODEL B13 SERIES

## QUICK REFERENCE INDEX

GENERAL INFORMATION	GI
MAINTENANCE	MA
ENGINE MECHANICAL	EM
ENGINE LUBRICATION & COOLING SYSTEMS	LC
ENGINE FUEL & EMISSION CONTROL SYSTEM	EF&EC
ACCELERATOR CONTROL, FUEL & EXHAUST SYSTEMS	FE
CLUTCH	CL
MANUAL TRANSAXLE	MT
AUTOMATIC TRANSAXLE	AT
FRONT AXLE & FRONT SUSPENSION	FA
REAR AXLE & REAR SUSPENSION	RA
BRAKE SYSTEM	BR
STEERING SYSTEM	ST
BODY	BF
HEATER & AIR CONDITIONER	HA
ELECTRICAL SYSTEM	EL
ALPHABETICAL INDEX	IDX

CLICK HERE TO **DOWNLOAD** THE COMPLETE MANUAL

- Thank you very much for reading the preview of the manual.
- You can download the complete manual from: [www.heydownloads.com](http://www.heydownloads.com) by clicking the link below



- Please note: If there is no response to CLICKING the link, please download this PDF first and then click on it.

CLICK HERE TO **DOWNLOAD** THE COMPLETE MANUAL

# DESCRIPTION

## Hydraulic Control Circuit — RL4F03A

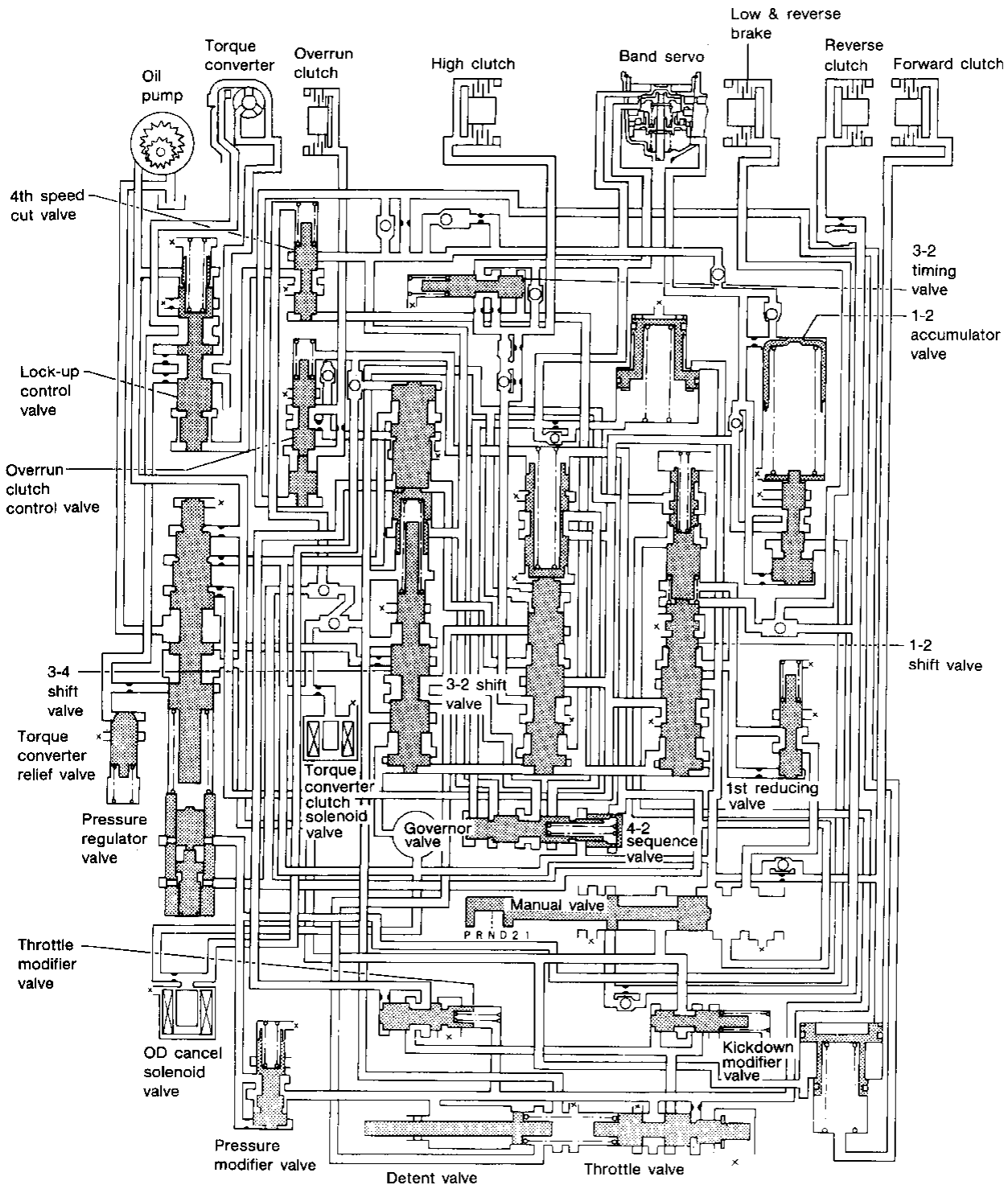

- X : Drain part
- △ : Orifice

MAT231AA

# TROUBLE DIAGNOSES

RL4F03A

## Road Testing (Cont'd)

ON VEHICLE										OFF VEHICLE																		
Kickdown modifier valve	1-2 accumulator valve	3-2 timing valve	1st reducing valve	Torque converter relief valve	Throttle modifier valve	4th speed cut valve	Lock-up control valve	4-2 sequence valve	Governor pressure	Governor valve	OD cancel solenoid valve	Torque converter clutch solenoid valve	Accumulator servo release	Accumulator N-D	Ignition switch and starter motor	OD control switch and wiring	Torque converter	Oil pump	Reverse clutch	High clutch	Forward clutch	Forward one-way clutch	Overrun clutch	Low one-way clutch	Low & reverse clutch	Brake band	Parking components	
									4	5	.	.	.	.	.	.	.	.	.	.	.	.	.	.	.	.	.	.
									4	5	.	.	.	.	.	.	.	.	.	.	.	.	.	.	.	.	.	.
									4	5	.	.	.	.	.	.	.	.	.	.	.	.	.	.	.	.	.	.
									4	5	.	.	.	.	.	.	.	.	.	.	.	.	.	.	.	.	.	.
									4	5	7	.	.	.	.	8	.	.	.	.	.	.	.	.	.	.	.	.
									4	5	.	.	.	.	.	.	.	.	.	.	.	.	.	.	.	.	.	.
									4	5	.	.	.	.	.	.	.	.	.	.	.	.	.	.	.	.	.	.
									4	5	.	.	.	.	.	.	.	.	.	.	.	.	.	.	.	.	.	.
									4	5	.	6	.	.	.	.	8	.	.	.	.	.	.	.	.	.	.	.
									.	.	.	3	.	.	.	.	4	.	.	.	.	.	.	.	.	.	.	.
									.	.	.	.	.	.	1	.	.	.	.	.	.	.	.	.	.	.	.	.
									.	.	.	.	.	.	.	.	.	.	.	.	.	.	.	.	.	.	.	2

GI  
MA  
EM  
LC  
EF & EC  
FE  
CL  
MT  
AT  
FA  
RA  
BR  
ST  
BF  
HA  
EL  
DX

**How to Perform Trouble Diagnoses for Quick and Accurate Repair (Cont'd)**

	<p><b>Part-2</b></p> <ul style="list-style-type: none"> <li><input type="checkbox"/> Diagnostic Procedure 11 (Vehicle starts from D<sub>1</sub>)</li> <li><input type="checkbox"/> Diagnostic Procedure 12 (Kickdown: D<sub>4</sub> → D<sub>2</sub>)</li> <li><input type="checkbox"/> Diagnostic Procedure 13 (Shift schedule: D<sub>2</sub> → D<sub>3</sub>)</li> <li><input type="checkbox"/> Diagnostic Procedure 14 (Shift schedule: D<sub>3</sub> → D<sub>4</sub> and engine brake)</li> </ul>	<p>AT-52</p>		
	<p><b>Part-3</b></p> <ul style="list-style-type: none"> <li><input type="checkbox"/> Diagnostic Procedure 20 (D<sub>4</sub> → D<sub>3</sub> when OD OFF switch ON → OFF)</li> <li><input type="checkbox"/> Diagnostic Procedure 18 (Engine brake in D<sub>3</sub>)</li> <li><input type="checkbox"/> Diagnostic Procedure 21 (D<sub>3</sub> → 2<sub>2</sub> when selector lever D → 2 position)</li> <li><input type="checkbox"/> Diagnostic Procedure 19 (Engine brake in 2<sub>2</sub>)</li> <li><input type="checkbox"/> Diagnostic Procedure 22 (2<sub>2</sub> → 1<sub>1</sub>, when selector lever 2 → 1 position)</li> <li><input type="checkbox"/> Diagnostic Procedure 23 (Engine brake in 1<sub>1</sub>)</li> <li><input type="checkbox"/> SELF-DIAGNOSTIC PROCEDURE — Mark detected items.             <table style="width: 100%; border: none;"> <tr> <td style="width: 50%; vertical-align: top;"> <ul style="list-style-type: none"> <li><input type="checkbox"/> 1. Revolution sensor</li> <li><input type="checkbox"/> 2. Vehicle speed sensor</li> <li><input type="checkbox"/> 3. Throttle position sensor</li> <li><input type="checkbox"/> 4. Shift solenoid valve A</li> <li><input type="checkbox"/> 5. Shift solenoid valve B</li> <li><input type="checkbox"/> 6. Timing solenoid valve</li> <li><input type="checkbox"/> 7. Torque converter clutch solenoid valve</li> </ul> </td> <td style="width: 50%; vertical-align: top;"> <ul style="list-style-type: none"> <li><input type="checkbox"/> 8. Fluid temperature sensor and A/T control unit power source</li> <li><input type="checkbox"/> 9. Engine speed signal</li> <li><input type="checkbox"/> 10. Line pressure solenoid valve</li> <li><input type="checkbox"/> 11. Battery</li> <li><input type="checkbox"/> 12. Others</li> </ul> </td> </tr> </table> </li> </ul>	<ul style="list-style-type: none"> <li><input type="checkbox"/> 1. Revolution sensor</li> <li><input type="checkbox"/> 2. Vehicle speed sensor</li> <li><input type="checkbox"/> 3. Throttle position sensor</li> <li><input type="checkbox"/> 4. Shift solenoid valve A</li> <li><input type="checkbox"/> 5. Shift solenoid valve B</li> <li><input type="checkbox"/> 6. Timing solenoid valve</li> <li><input type="checkbox"/> 7. Torque converter clutch solenoid valve</li> </ul>	<ul style="list-style-type: none"> <li><input type="checkbox"/> 8. Fluid temperature sensor and A/T control unit power source</li> <li><input type="checkbox"/> 9. Engine speed signal</li> <li><input type="checkbox"/> 10. Line pressure solenoid valve</li> <li><input type="checkbox"/> 11. Battery</li> <li><input type="checkbox"/> 12. Others</li> </ul>	<p>AT-53</p>
<ul style="list-style-type: none"> <li><input type="checkbox"/> 1. Revolution sensor</li> <li><input type="checkbox"/> 2. Vehicle speed sensor</li> <li><input type="checkbox"/> 3. Throttle position sensor</li> <li><input type="checkbox"/> 4. Shift solenoid valve A</li> <li><input type="checkbox"/> 5. Shift solenoid valve B</li> <li><input type="checkbox"/> 6. Timing solenoid valve</li> <li><input type="checkbox"/> 7. Torque converter clutch solenoid valve</li> </ul>	<ul style="list-style-type: none"> <li><input type="checkbox"/> 8. Fluid temperature sensor and A/T control unit power source</li> <li><input type="checkbox"/> 9. Engine speed signal</li> <li><input type="checkbox"/> 10. Line pressure solenoid valve</li> <li><input type="checkbox"/> 11. Battery</li> <li><input type="checkbox"/> 12. Others</li> </ul>			
<p>4.</p>	<p><input type="checkbox"/> Perform the Diagnostic Procedures marked in ROAD TESTING. Refer to the Symptom Chart when you perform the procedures. (The chart also shows some other possible symptoms and the components inspection orders.)</p>	<p>AT-105</p>		
<p>5.</p>	<p>Perform FINAL CHECK. If NG, go back to "CHECK A/T FLUID".</p> <ul style="list-style-type: none"> <li><input type="checkbox"/> Stall test — Mark possible damaged components/others.             <table style="width: 100%; border: none;"> <tr> <td style="width: 50%; vertical-align: top;"> <ul style="list-style-type: none"> <li><input type="checkbox"/> Torque converter one-way clutch</li> <li><input type="checkbox"/> Reverse clutch</li> <li><input type="checkbox"/> Forward clutch</li> <li><input type="checkbox"/> Overrun clutch</li> <li><input type="checkbox"/> Forward one-way clutch</li> </ul> </td> <td style="width: 50%; vertical-align: top;"> <ul style="list-style-type: none"> <li><input type="checkbox"/> Low &amp; reverse brake</li> <li><input type="checkbox"/> Low one-way clutch</li> <li><input type="checkbox"/> Engine</li> <li><input type="checkbox"/> Line pressure is low</li> <li><input type="checkbox"/> Clutches and brakes except high clutch and brake band are OK</li> </ul> </td> </tr> </table> </li> <li><input type="checkbox"/> Pressure test — Suspected parts:</li> </ul>	<ul style="list-style-type: none"> <li><input type="checkbox"/> Torque converter one-way clutch</li> <li><input type="checkbox"/> Reverse clutch</li> <li><input type="checkbox"/> Forward clutch</li> <li><input type="checkbox"/> Overrun clutch</li> <li><input type="checkbox"/> Forward one-way clutch</li> </ul>	<ul style="list-style-type: none"> <li><input type="checkbox"/> Low &amp; reverse brake</li> <li><input type="checkbox"/> Low one-way clutch</li> <li><input type="checkbox"/> Engine</li> <li><input type="checkbox"/> Line pressure is low</li> <li><input type="checkbox"/> Clutches and brakes except high clutch and brake band are OK</li> </ul>	<p>AT-100</p>
<ul style="list-style-type: none"> <li><input type="checkbox"/> Torque converter one-way clutch</li> <li><input type="checkbox"/> Reverse clutch</li> <li><input type="checkbox"/> Forward clutch</li> <li><input type="checkbox"/> Overrun clutch</li> <li><input type="checkbox"/> Forward one-way clutch</li> </ul>	<ul style="list-style-type: none"> <li><input type="checkbox"/> Low &amp; reverse brake</li> <li><input type="checkbox"/> Low one-way clutch</li> <li><input type="checkbox"/> Engine</li> <li><input type="checkbox"/> Line pressure is low</li> <li><input type="checkbox"/> Clutches and brakes except high clutch and brake band are OK</li> </ul>			

Preliminary Check (Cont'd)

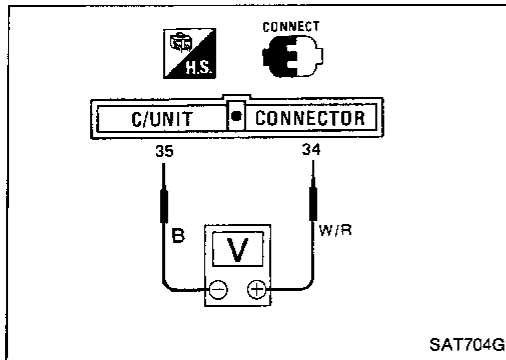

Without CONSULT

- Throttle position can be controlled by voltage across terminals ④ and ⑤ of A/T control unit.

Cruise test — Part 1

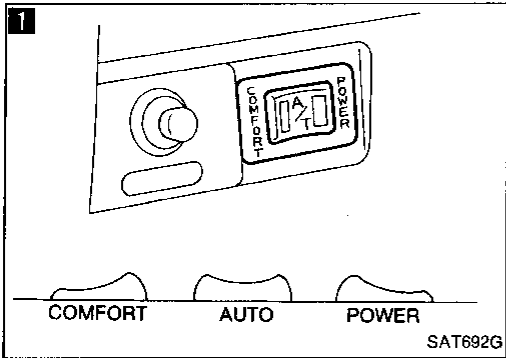

1. Warm up engine until engine oil and ATF reach operating temperature after vehicle has been driven approx. 10 minutes.  
**ATF operating temperature:**  
50 - 80°C (122 - 176°F)

1. Park vehicle on flat surface.  
2. Set A/T mode switch to "AUTO" position.

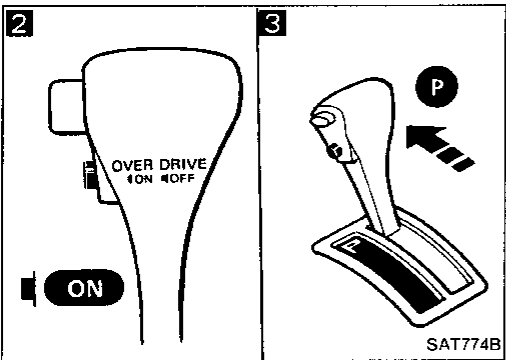

2. Set overdrive switch to "ON" position.

3. 1. Move selector lever to "P" position.  
2. Start engine.

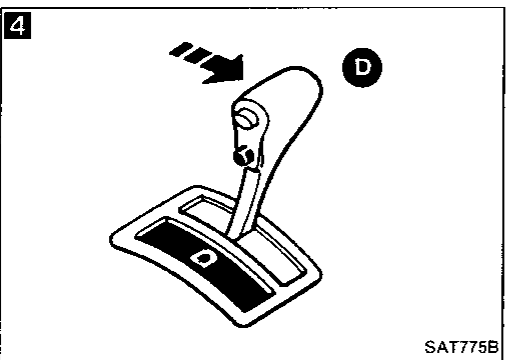

4. Move selector lever to "D" position.

Ⓐ

GI

MA

EM

LC

EF &  
EC

FE

CL

MT

**AT**

FA

RA

BR

ST

BF

HA

EL

IDX

Self-diagnosis (Cont'd)

REVOLUTION SENSOR CIRCUIT CHECK

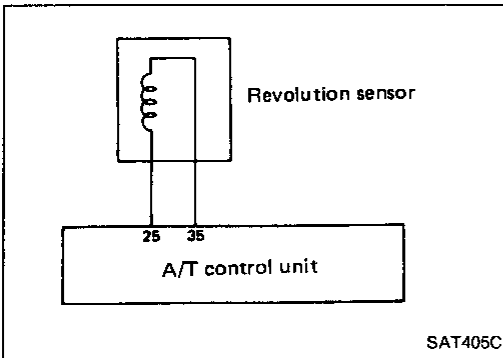

**A**

☆MONITOR ☆NO FAIL	
VHCL/S SE-A/T	0km/h
VHCL/S SE-MTR	5km/h
THRTL POS SEN	0.4V
FLUID TEMP SE	1.2V
BATTERY VOLT	13.4V
ENGINE SPEED	1024rpm
OVERDRIVE SW	O N
P/N POSI SW	O N
R POSITION SW	OFF

RECORD

SAT076H

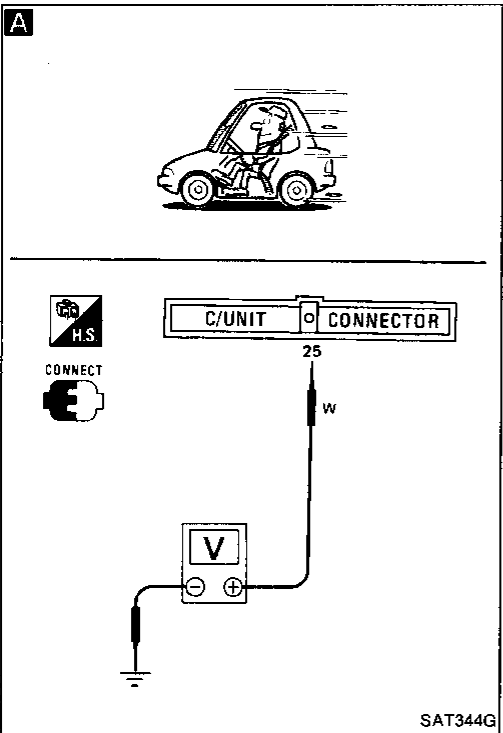

```

    graph TD
      Start[CHECK REVOLUTION SENSOR. —  
Refer to "Electrical Components  
Inspection", AT-100.] -- NG --> Repair[Repair or replace revolu-  
tion sensor.]
      Start -- OK --> A1[A]
      A1[CHECK INPUT SIGNAL.  
1. Turn ignition switch to "START"  
position and start engine.  
2. ● Select "ECU INPUT SIGNALS"  
in Data Monitor.  
● Read out the value of "VHCL/S  
SE-A/T" while driving.  
● Check the value changes  
according to driving speed.] -- NG --> A2[Check the following  
items.  
● Harness continuity  
between A/T control  
unit and revolution sen-  
sor (Main harness)  
● Harness continuity  
between revolution  
sensor and ECM (Main  
harness)  
● Ground circuit for ECM  
— Refer to section EF  
& EC.]
      A1 -- OR --> A2
      A2 -- OK --> A3[2. Check voltage between A/T con-  
trol unit terminal 25 and ground  
while driving.  
(Measure with AC range.)  
Voltage:  
At 0 km/h (0 MPH):  
0V  
At 30 km/h (19 MPH):  
1V or more  
(Voltage rises gradually in  
response to vehicle speed.)]
      A3 -- OK --> A4[Perform self-diagnosis again after driv-  
ing for a while.]
      A4 -- NG --> A5[1. Perform A/T control  
unit input/output signal  
inspection.  
2. If NG, recheck A/T  
control unit pin termi-  
nals for damage or  
connection of A/T con-  
trol unit harness con-  
nector.]
      A4 -- OK --> End[INSPECTION END]
  
```

Self-diagnosis (Cont'd)

**C D**

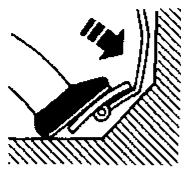

☆ MONITOR	☆ NO FAIL	
D POSITION SW	OFF	
2 POSITION SW	OFF	
1 POSITION SW	OFF	
ASCD•CRUISE	OFF	
ASCD•OD CUT	OFF	
KICKDOWN SW	OFF	
POWERSHIFT SW	OFF	
CLOSED THL/SW	O N	
W/O THRL/P-SW	OFF	

RECORD

SAT714G

**C D**

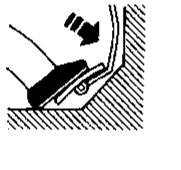
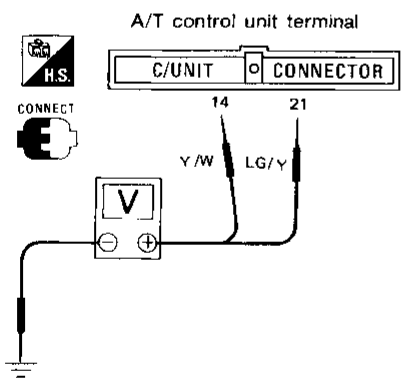
A/T control unit terminal

CONNECT

H.S.

C/UNIT CONNECTOR

14 21

Y/W LG/Y

V

SAT715G

B

**C**

**CHECK WIDE OPEN THROTTLE POSITION SWITCH CIRCUIT.**

1. Turn ignition switch to "ON" position.  
(Do not start engine.)

2.  • Select "ECU INPUT SIGNALS" in Data Monitor.  
• Read out "W/O THRL/P-SW" depressing accelerator pedal fully.  
• Check the signal of wide open throttle position switch is indicated properly.

OR

2.  • Check voltage between A/T control unit terminal ⑳ and ground while depressing accelerator pedal slowly. (after warming up engine)

**Voltage:**

**When releasing accelerator pedal:**  
1V or less

**When depressing accelerator pedal fully:**  
8 - 15V

OK

C

NG → Check harness continuity between A/T control unit and wide open throttle position switch.

CI  
VA  
EM  
LC  
EF & EC  
FE  
CL  
WT  
AT  
FA  
RA  
BR  
ST  
BF  
HA  
EL  
IDX

**Diagnostic Procedure 14**

**SYMPTOM:**

**A/T does not shift from D<sub>3</sub> to D<sub>4</sub> at the specified speed.**

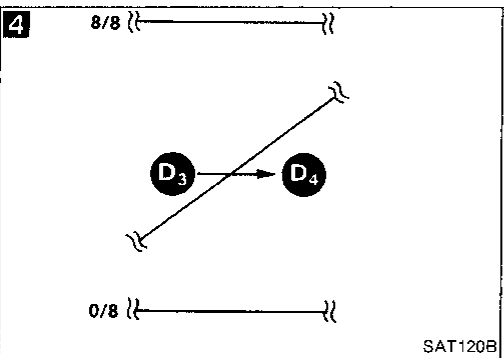
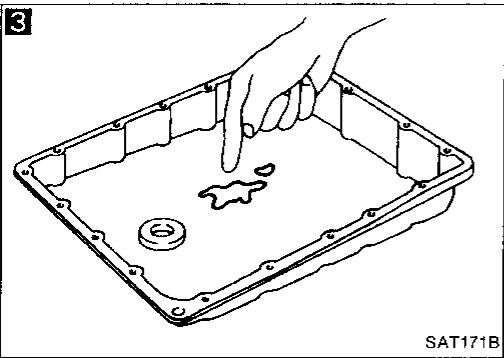
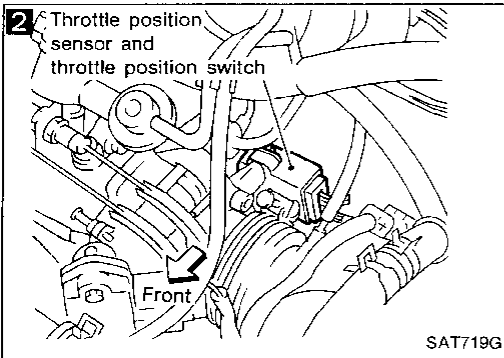
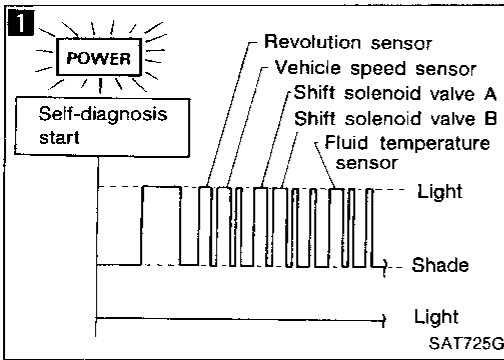

```

    graph TD
        Q1[Are Diagnostic Procedure 10 and 11 OK?] -- No --> A1[Go to Diagnostic Procedure 10 or 11, AT-84, 85.]
        Q1 -- Yes --> Q2[Does self-diagnosis show damage to inhibitor switch, overdrive switch, shift solenoid valve A, B, revolution sensor, vehicle speed sensor or fluid temperature sensor circuit after road test?]
        
        Q2 -- Yes --> A2[Check damaged circuit. — Refer to "Self-diagnosis", AT-60.]
        Q2 -- No --> Q3[Check throttle position sensor. — Refer to section EF & EC.]
        
        Q3 -- NG --> A3[Repair or replace throttle position sensor.]
        Q3 -- OK --> Q4[1. Remove oil pan. 2. Check A/T fluid condition.]
        
        Q4 -- NG --> A4[1. Remove control valve assembly. — Refer to "ON-VEHICLE SERVICE", AT-118. 2. Check the following items. • Shift valve B • Overrun clutch control valve • Shift solenoid valve B • Pilot valve • Pilot filter 3. Disassemble A/T. 4. Check the following items. • Servo piston assembly • Brake band • Torque converter • Oil pump assembly]
        Q4 -- OK --> Q5[1. Remove control valve assembly. — Refer to "ON-VEHICLE SERVICE", AT-118. 2. Check the following items. • Shift valve B • Overrun clutch control valve • Shift solenoid valve B • Pilot valve • Pilot filter]
        
        Q5 -- OK --> Q6[Check again.]
        Q5 -- NG --> A5[1. Perform A/T control unit input/output signal inspection. 2. If NG, recheck A/T control unit pin terminals for damage or connection of A/T control unit harness connector.]
        
        Q6 -- OK --> END[INSPECTION END]
        Q6 -- NG --> A5
    
```

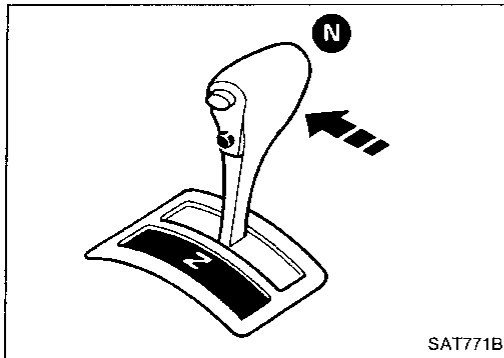
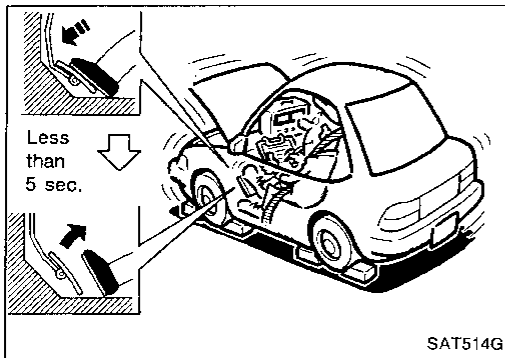

## Final Check (Cont'd)

5. Start engine, apply foot brake, and place selector lever in "D" position.
6. Accelerate to wide-open throttle gradually while applying foot brake.
7. Quickly note the engine stall revolution and immediately release throttle.

- **During test, never hold throttle wide-open for more than 5 seconds.**

Stall revolution:

1,850 - 2,150 rpm

8. Shift selector lever to "N" position.
9. Cool off ATF.

- **Run engine at idle for at least one minute.**

10. Perform stall tests in the same manner as in steps 5 through 9 with selector lever in "2", "1" and "R" positions, respectively.

## JUDGEMENT OF STALL TEST

The test result and possible damaged components relating to each result are shown in the illustration. In order to pinpoint the possible damaged components, follow the WORK FLOW shown in AT-33.

## Note

## Stall revolution is too high in "D" or "2" position:

- Slippage occurs in 1st gear but not in 2nd and 3rd gears. .... Low one-way clutch slippage
- Slippage occurs in 1st through 3rd gears in "D" position and engine brake functions with power shift switch set to "POWER", or slippage occurs in 1st and 2nd gears in "2" position and engine brake functions with accelerator pedal completely released (fully closed throttle). .... Forward clutch or forward one-way clutch slippage

## Stall revolution is too high in "R" position:

- Engine brake does not function in "1" position. .... Low & reverse brake slippage
- Engine brake functions in "1" position. .... Reverse clutch slippage

## Stall revolution within specifications:

- Vehicle does not achieve speed of more than 80 km/h. .... One-way clutch seizure in torque converter housing

## CAUTION:

**Be careful since automatic fluid temperature increases abnormally.**

- Slippage occurs in 3rd and 4th gears in "D" position. .... High clutch slippage
- Slippage occurs in 2nd and 4th gear in "D" position. .... Brake band slippage

## Stall revolution less than specifications:

- Poor acceleration during starts. .... One-way clutch seizure in torque converter

# TROUBLE DIAGNOSES — A/T Shift Lock System

## Diagnostic Procedure (Cont'd)

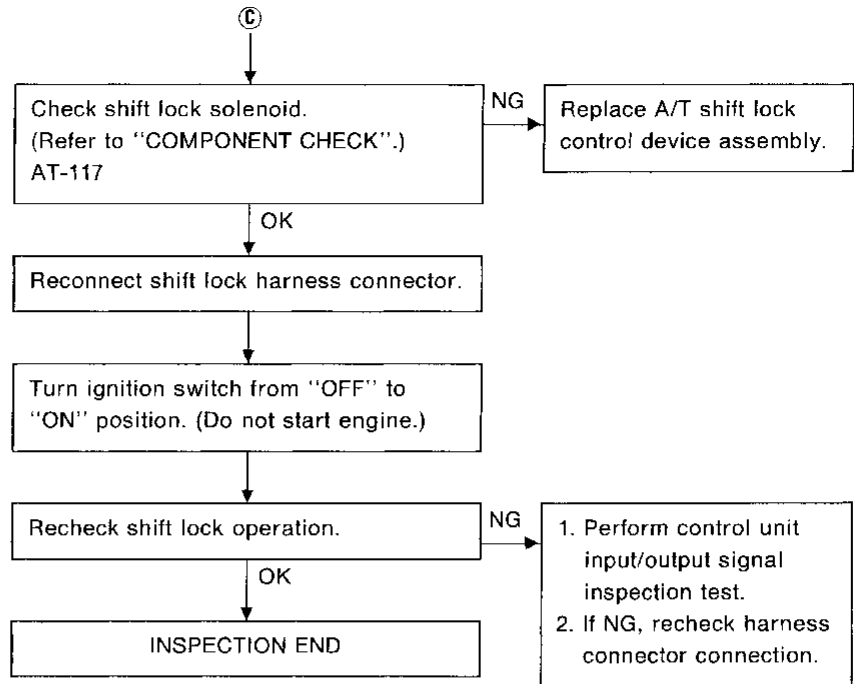

# MAJOR OVERHAUL

## RL4F03A

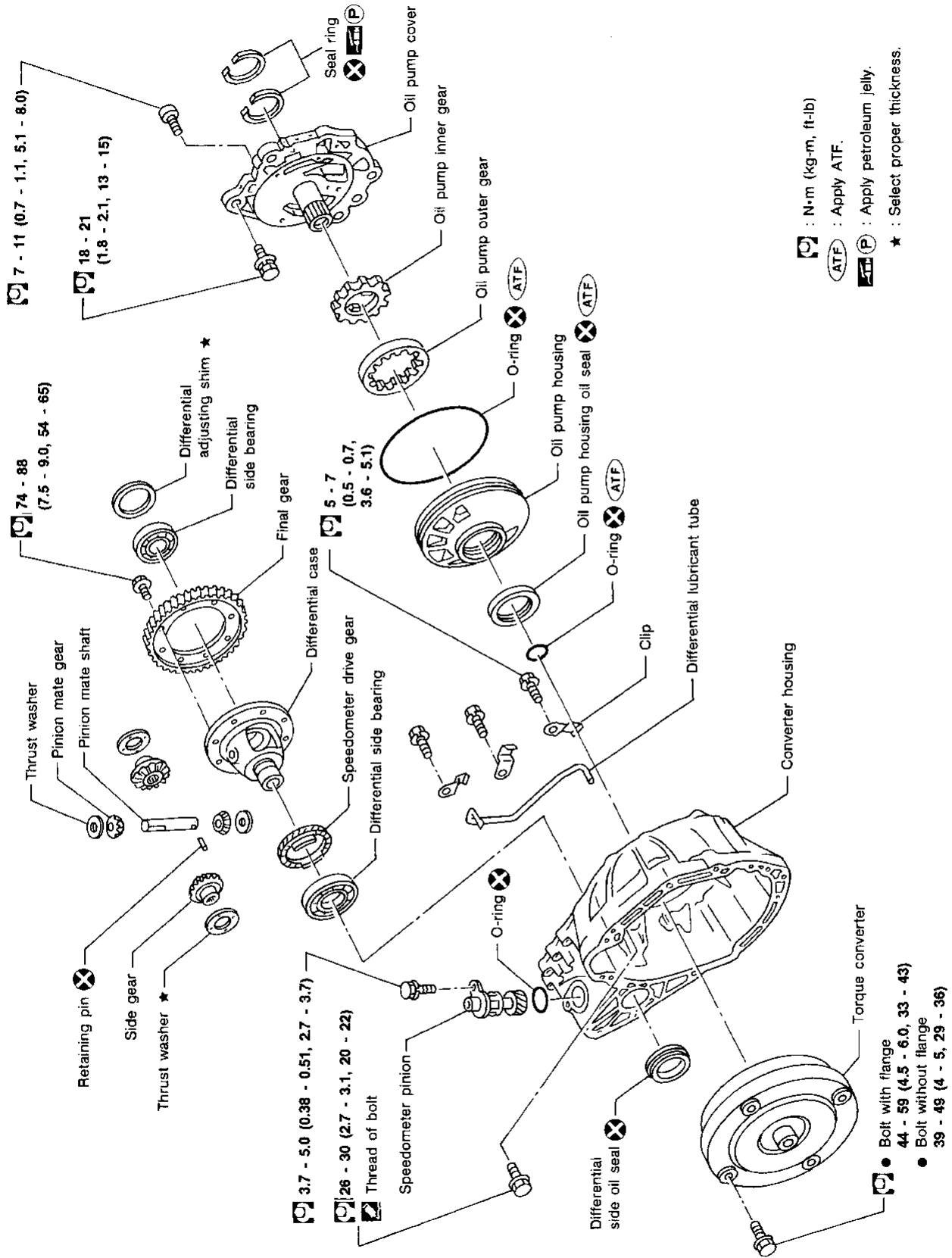

- GI
- MA
- EM
- LC
- EF & EC
- FE
- CL
- MT
- AT**
- FA
- RA
- BR
- ST
- BF
- HA
- EL
- IDX

# DISASSEMBLY

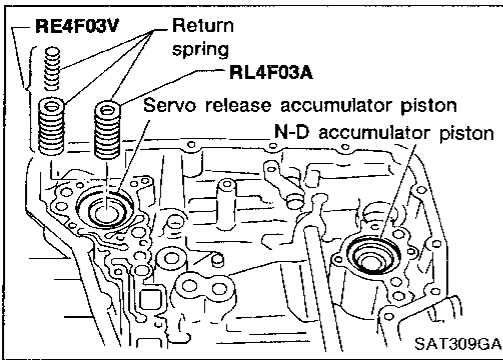

11. Remove return spring from servo release accumulator piston.

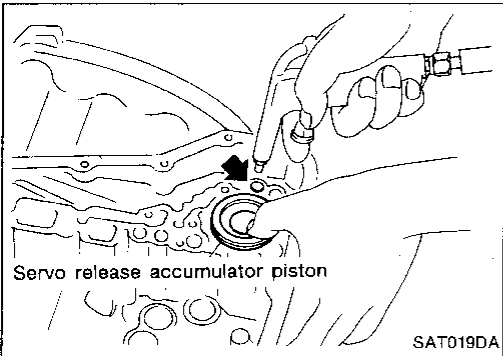

12. Remove servo release accumulator piston with compressed air.

13. Remove O-rings from servo release accumulator piston.

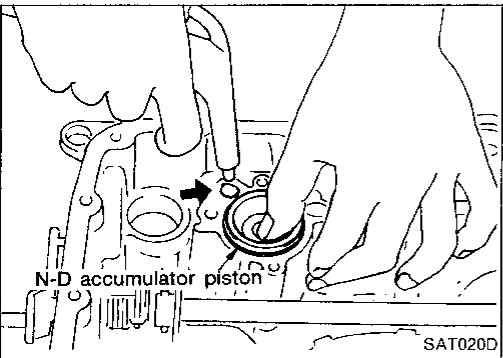

14. Remove N-D accumulator piston and return spring with compressed air.

15. Remove O-rings from N-D accumulator piston.

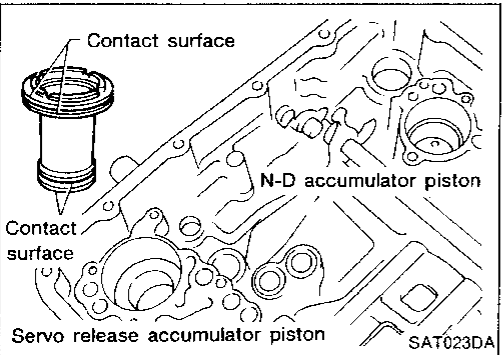

16. Check accumulator pistons and contact surface of transmission case for damage.

17. Check accumulator return springs for damage and free length.

## RL4F03A

Unit: mm (in)

Spring	Free length	Outer diameter
Servo release accumulator spring	56.4 (2.220)	21.0 (0.827)
N-D accumulator spring	43.5 (1.713)	28.0 (1.102)

## RE4F03V

Unit: mm (in)

Spring		Free length	Outer diameter
Servo release accumulator spring	Outer	52.5 (2.067)	19.6 (0.772)
	Inner	52.0 (2.047)	15.1 (0.594)
N-D accumulator spring		43.5 (1.713)	28.0 (1.102)

## DISASSEMBLY

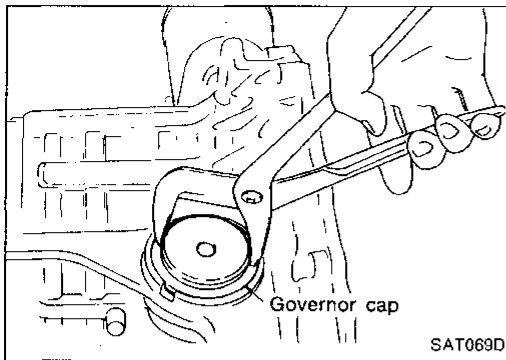

- c. Remove governor cap using water pump pliers.
- d. Remove O-ring from governor cap.

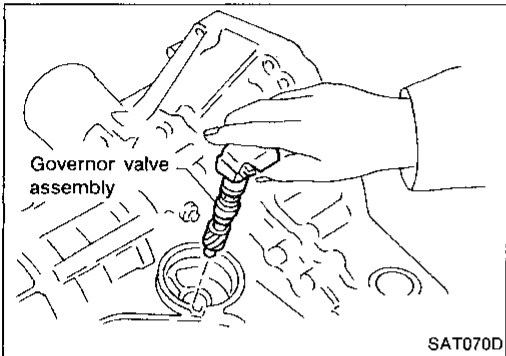

- e. Remove governor valve assembly.

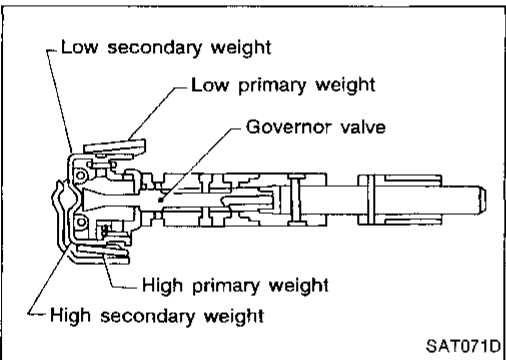

- f. With low primary weight closed, place top of governor valve assembly down to make sure governor valve properly lowers under its own weight.
- g. Place top of governor assembly down. Operate both low and high secondary weights to make sure governor valve functions properly.

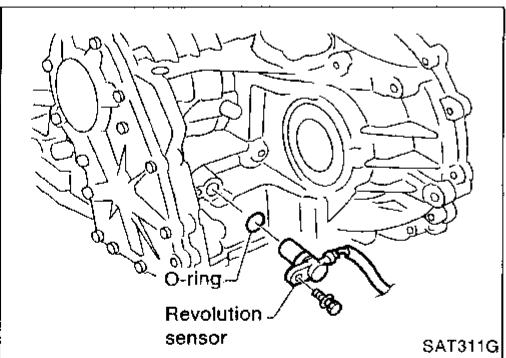

— RE4F03V only —

- 54. Remove revolution sensor from transmission case.

GI

MA

EM

LC

EF &  
EC

FE

CL

MT

AT

FA

RA

BR

ST

BF

HA

EL

IDX

## REPAIR FOR COMPONENT PARTS

### Control Valve Assembly — RL4F03A (Cont'd)

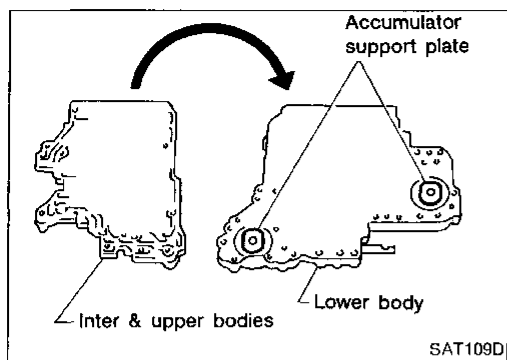

- f. Turn over lower body, and remove accumulator support plate.

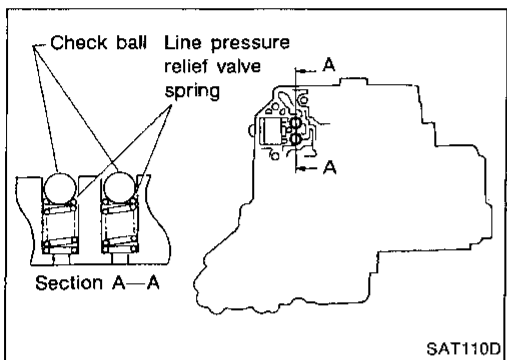

- g. Remove separating plate and separating gasket from lower body.  
 h. Remove steel balls and relief valve springs from lower body.  
 ● **Be careful not to lose steel balls and relief valve springs.**

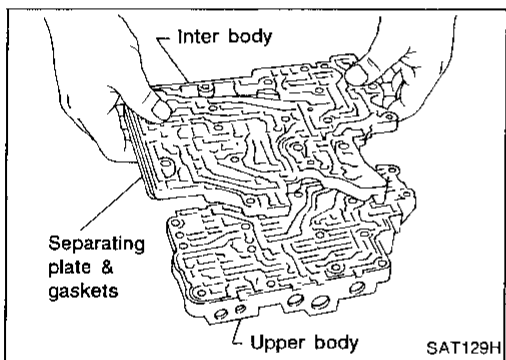

- i. Remove inter body with separating plate and separating gasket from upper body.

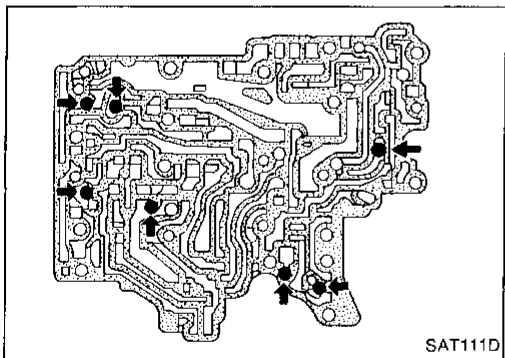

- j. Check to see that steel balls are properly positioned in inter body and then remove them from inter body.  
 ● **Be careful not to lose steel balls.**

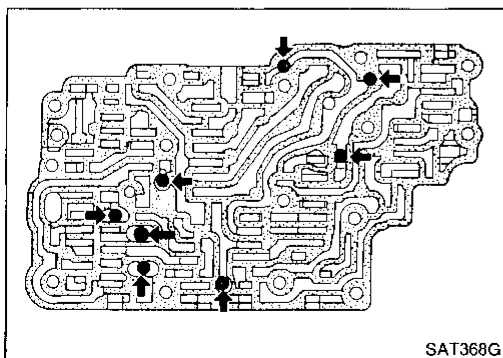

- k. Check to see that steel balls are properly positioned in upper body and then remove them from upper body.  
 ● **Be careful not to lose steel balls.**

# REPAIR FOR COMPONENT PARTS

## Control Valve Assembly — RE4F03V (Cont'd)

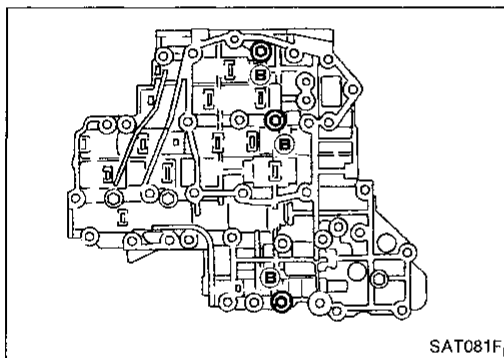
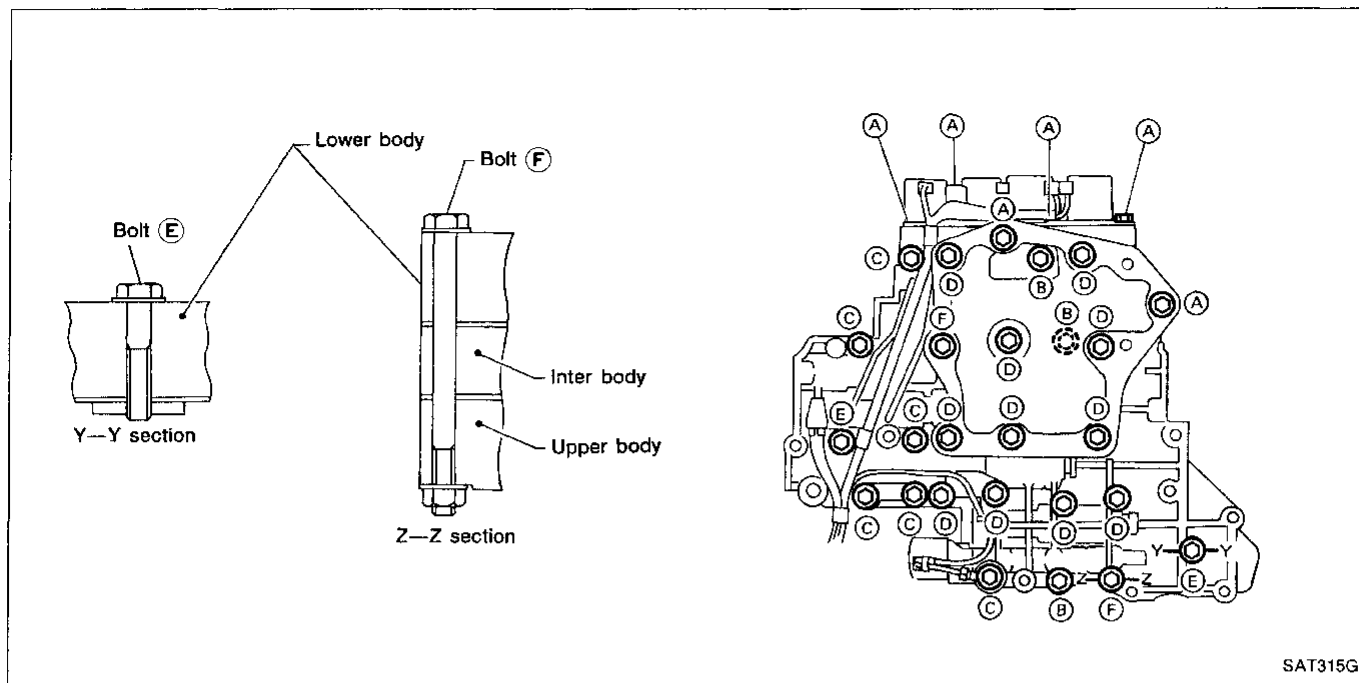

- a. Install and tighten bolts (B) to specified torque.

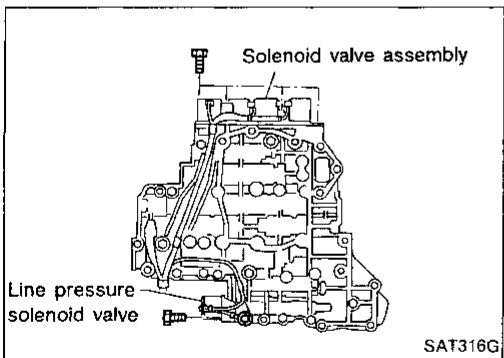

- b. Install solenoid valve assembly and line pressure solenoid valve to lower body.

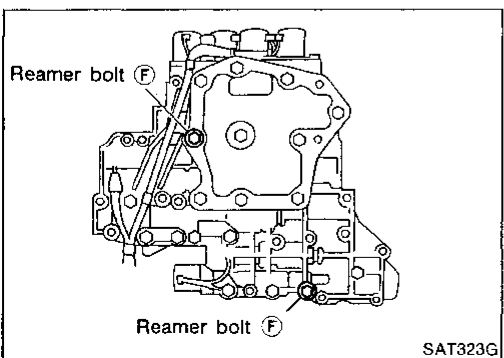

- c. Remove reamer bolts (E) and set oil strainer on control valve assembly.  
 d. Reinstall reamer bolts (E) from lower body side.

GI  
 VA  
 EM  
 LC  
 EF &  
 EC  
 FE  
 CL  
 MT  
**AT**  
 FA  
 RA  
 BR  
 ST  
 BF  
 HA  
 EL  
 IDX

Control Valve Lower Body — RE4F03V

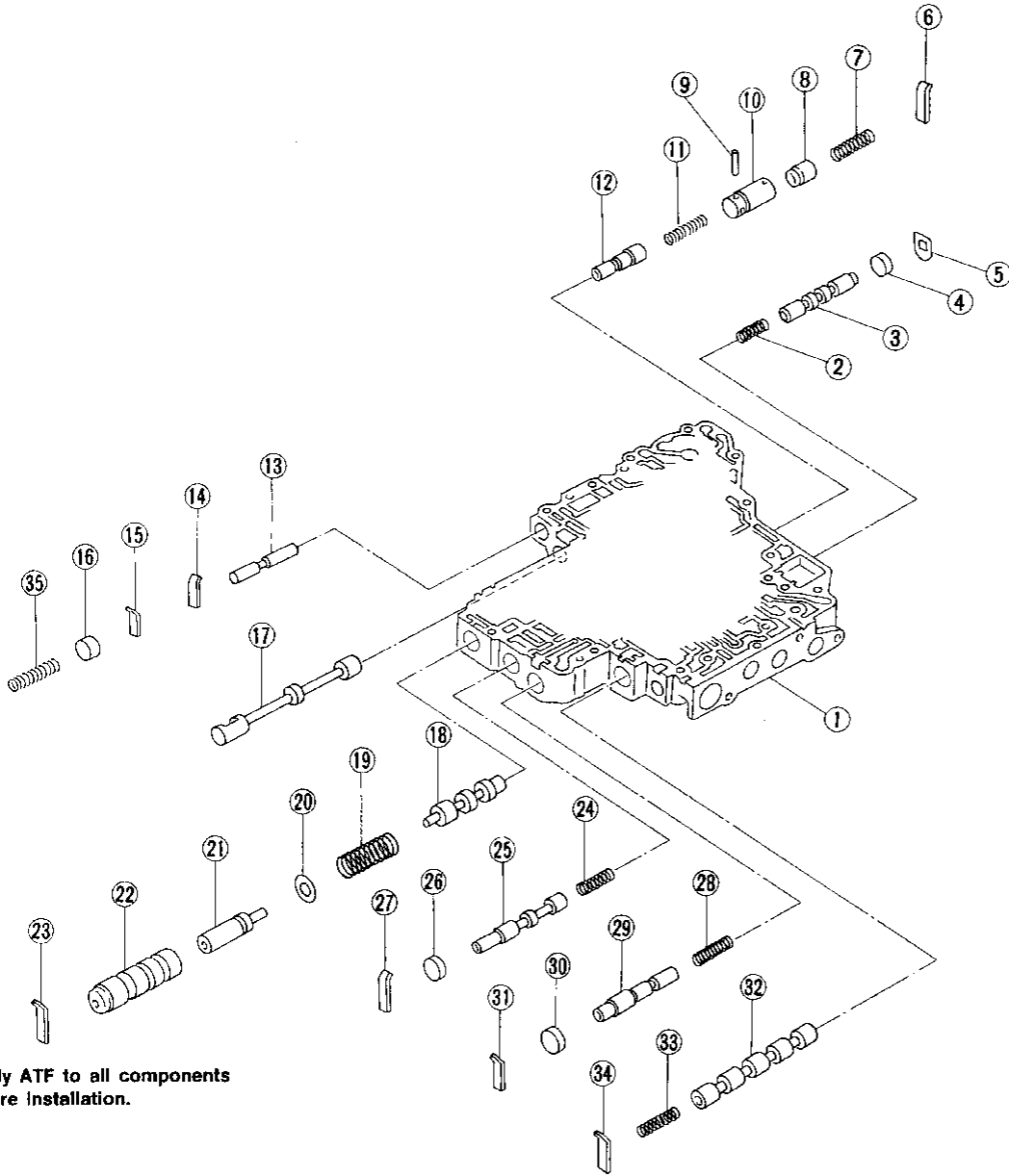

Apply ATF to all components before installation.

Numbers preceding valve springs correspond with those shown in SDS table on page AT-271.

SAT327GA

- |                            |                            |                                |
|----------------------------|----------------------------|--------------------------------|
| ① Control valve lower body | ⑬ Accumulator shift valve  | ⑳ Overrun clutch control valve |
| ② Return spring            | ⑭ Retainer plate           | ㉑ Plug                         |
| ③ Shift valve B            | ⑮ Retainer plate           | ㉒ Retaining plate              |
| ④ Plug                     | ⑯ Plug                     | ㉓ Return spring                |
| ⑤ Retainer plate           | ⑰ Manual valve             | ㉔ Accumulator control valve    |
| ⑥ Retainer plate           | ⑱ Pressure regulator valve | ㉕ Plug                         |
| ⑦ Return spring            | ⑲ Return spring            | ㉖ Retainer plate               |
| ⑧ Piston                   | ⑳ Spring seat              | ㉗ Shift valve A                |
| ⑨ Parallel pin             | ㉑ Plug                     | ㉘ Return spring                |
| ⑩ Sleeve                   | ㉒ Sleeve                   | ㉙ Retainer plate               |
| ⑪ Return spring            | ㉓ Retaining plate          | ㉚ Return spring                |
| ⑫ Pressure modifier valve  | ㉔ Return spring            |                                |

## REPAIR FOR COMPONENT PARTS

### Forward Clutch and Overrun Clutch (Cont'd)

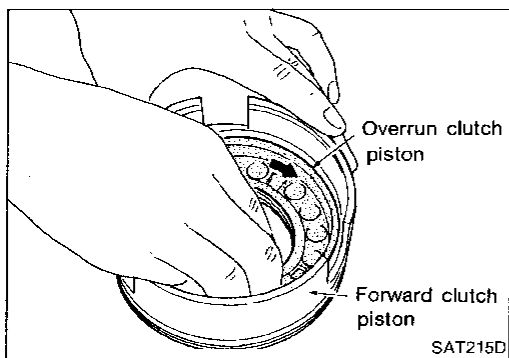

- Remove overrun clutch piston from forward clutch piston by turning it.

GI

MA

FM

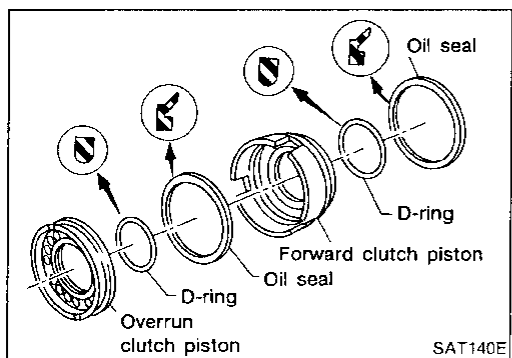

- Remove D-rings and oil seals from forward clutch piston and overrun clutch piston.

LC

EF &  
EC

FE

CL

### INSPECTION

#### Snap rings and spring retainer

- Check for deformation, fatigue or damage.

MT

AT

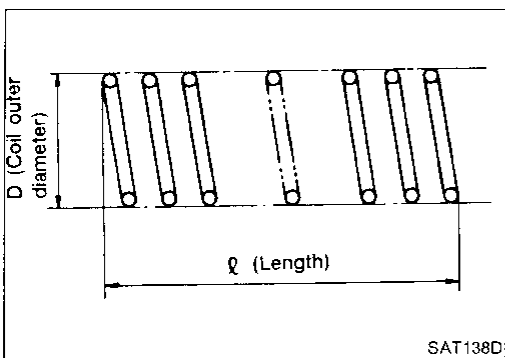

#### Forward clutch and overrun clutch return springs

- Check for deformation or damage.
- Measure free length and outer diameter.

#### Inspection standard:

Unit: mm (in)

Parts		Part No.	ℓ	D
Return spring	Inner	31505-31X03	26.3 (1.035)	7.7 (0.303)
	Outer	31505-31X02	26.6 (1.047)	10.6 (0.417)

ST

- Replace if deformed or fatigued.

BF

HA

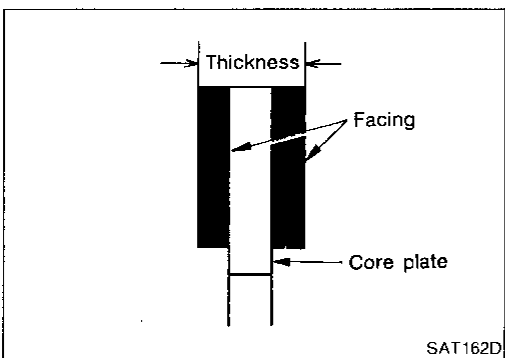

#### Forward clutch and overrun clutch drive plates

- Check facing for burns, cracks or damage.
- Measure thickness of facing.

#### Thickness of drive plate:

##### Forward clutch

Standard value: 1.8 mm (0.071 in)

Wear limit: 1.6 mm (0.063 in)

##### Overrun clutch

Standard value: 1.6 mm (0.063 in)

Wear limit: 1.4 mm (0.055 in)

- If not within wear limit, replace.

EL

IDX

## REPAIR FOR COMPONENT PARTS

### Output Shaft, Output Gear, Idler Gear, Reduction Gear and Bearing Retainer — RL4F03A (Cont'd)

3. Remove output shaft bearing outer race from bearing retainer.

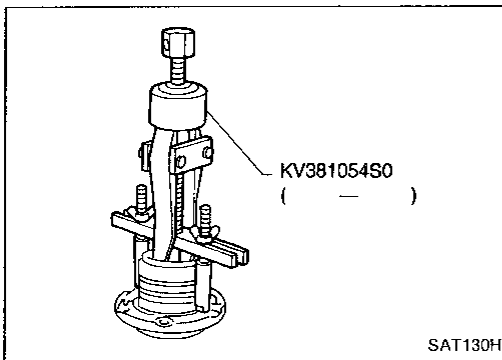

4. Remove output gear bearing inner race.

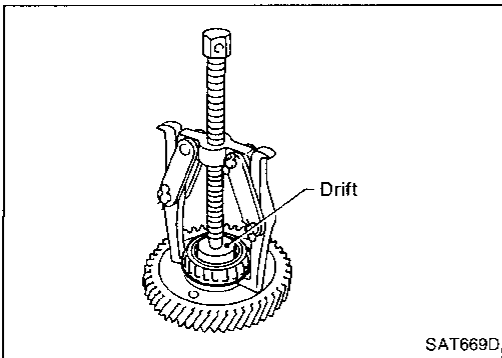

5. Remove output gear bearing outer race from bearing retainer.

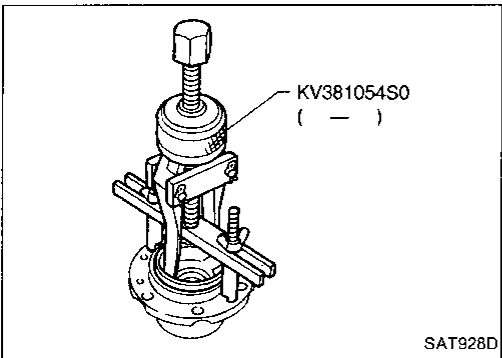

6. Remove idler gear bearing inner race.

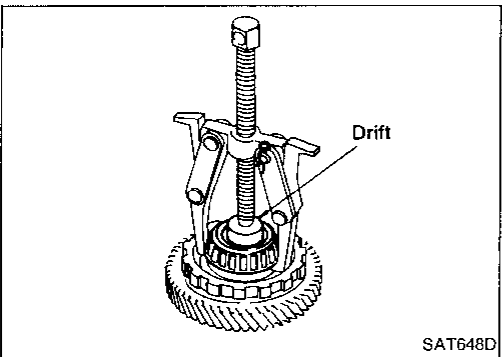

7. Remove idler gear bearing outer race from transmission case.

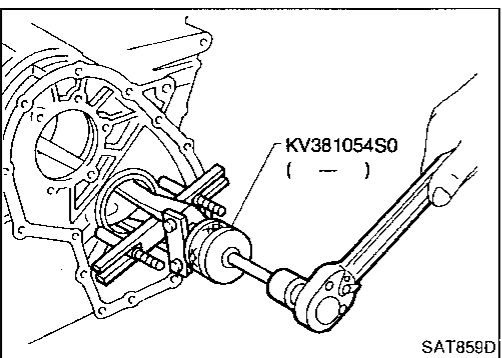

## REPAIR FOR COMPONENT PARTS

### Band Servo Piston Assembly (Cont'd)

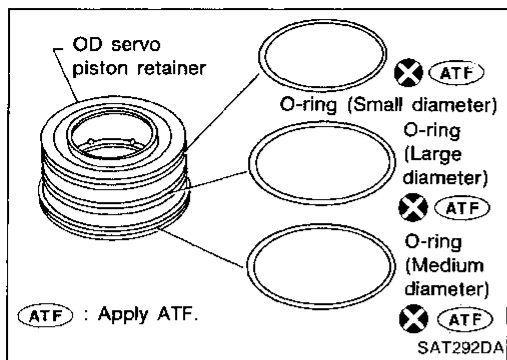

7. Install O-rings to OD servo piston retainer.
  - Apply ATF to O-rings.
  - Pay attention to the positions of the O-rings.

GI

MA

EM

LC

EF &  
EC

FE

CL

MT

AT

FA

RA

BR

ST

BF

HA

EL

IDX

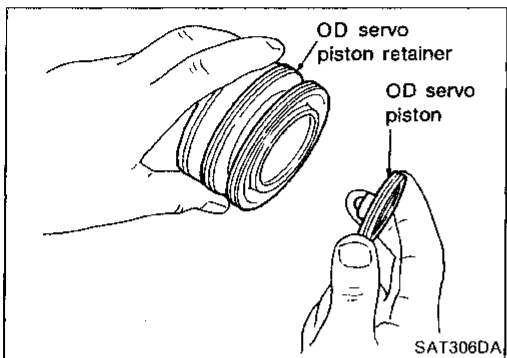

8. Install OD band servo piston to OD servo piston retainer.

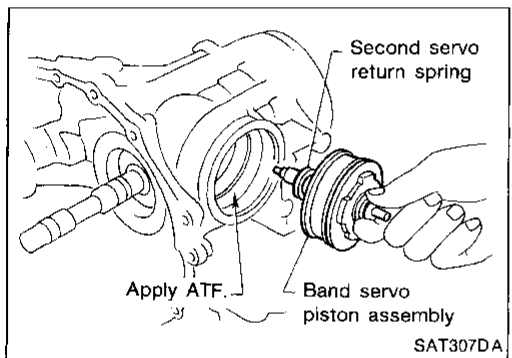

9. Install band servo piston assembly and 2nd servo return spring to transmission case.
  - Apply ATF to O-ring of band servo piston and transmission case.

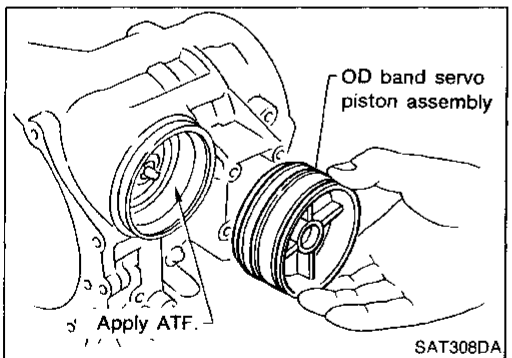

10. Install OD band servo piston assembly to transmission case.
  - Apply ATF to O-ring of band servo piston and transmission case.

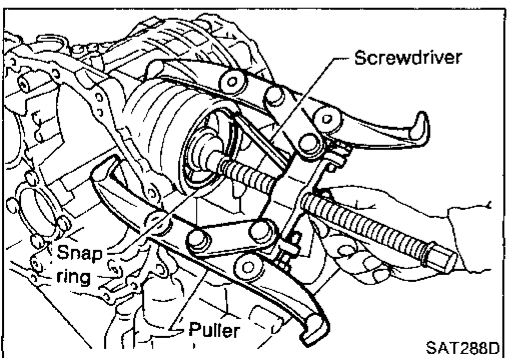

11. Install band servo piston snap ring to transmission case.

## ASSEMBLY

### Adjustment 1 (Cont'd)

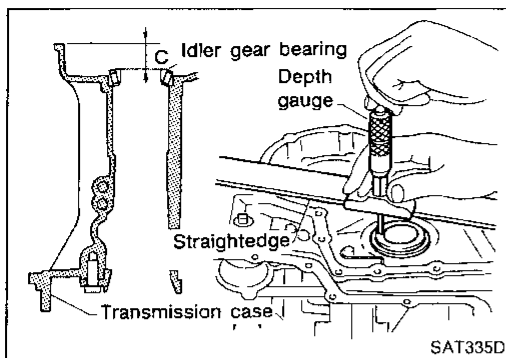

- Measure dimension "C" between the surface of idler gear bearing inner race and the surface of transmission case.
- **Measure dimension "C" in at least two places.**

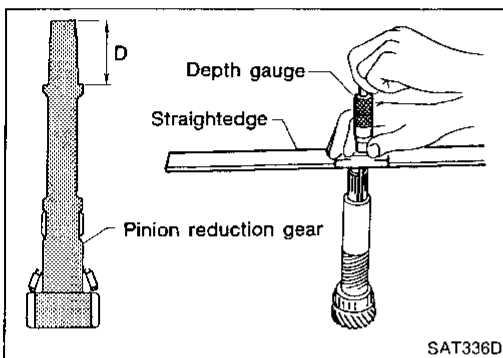

- Measure dimension "D" between the end of reduction gear and the adjusting shim mating surface of reduction gear.
- **Measure dimension "D" in at least two places.**
- Calculate dimension "A"  
 $A = D - (B + C)$

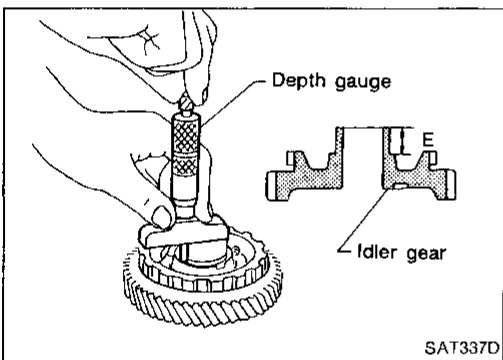

- Measure dimension "E" between the end of idler gear and the idler gear bearing inner race mating surface of idler gear.
- **Measure dimension "E" in at least two places.**

- Calculate "T" and select proper thickness of reduction gear bearing adjusting shim using SDS table as a guide.

$$T = A - E$$

**Reduction gear bearing adjusting shim: Refer to SDS, AT-278.**

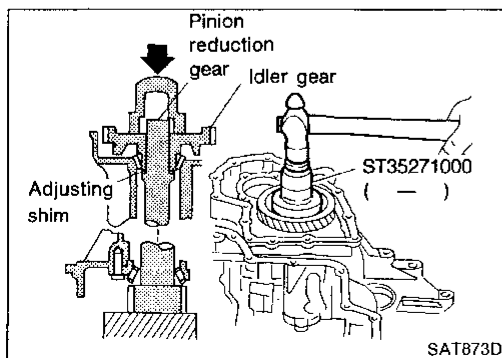

- Install reduction gear and reduction gear bearing adjusting shim selected in step 2-e on transmission case.
- Press idler gear bearing inner race on idler gear.
- Press idler gear on reduction gear.
- **Press idler gear so that idler gear can be locked by parking pawl.**

# ASSEMBLY

## Adjustment 2 (Cont'd)

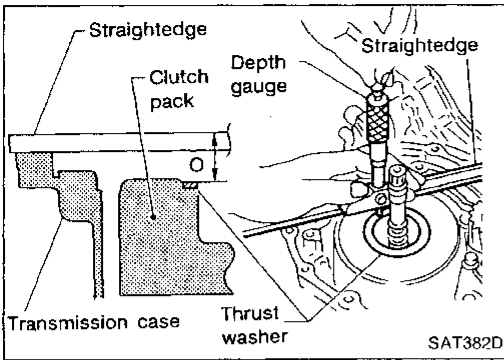

- a. Place thrust washer on reverse clutch drum.
- b. Measure dimension "O".

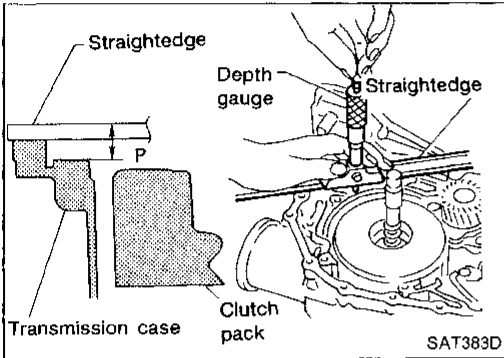

- c. Measure dimension "P".
- d. Calculate dimension "N".

**"N": Distance between oil pump fitting surface of transmission case and thrust washer on reverse clutch drum.**  

$$N = O - P$$

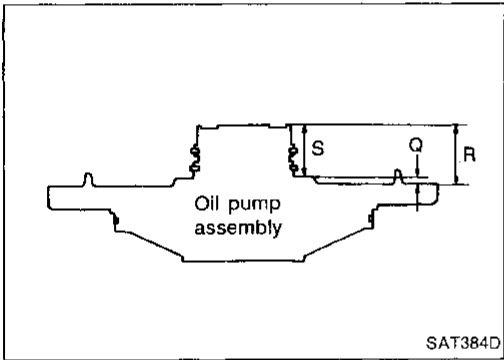

2. Measure dimensions "R" and "S" and then calculate dimension "Q".

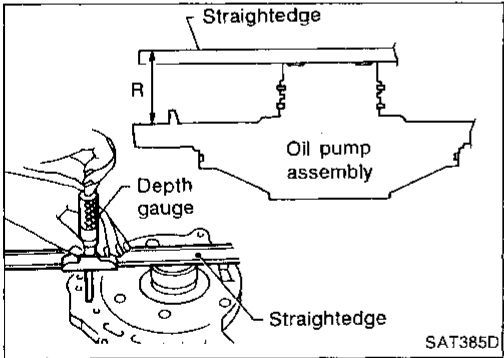

- a. Measure dimension "R".

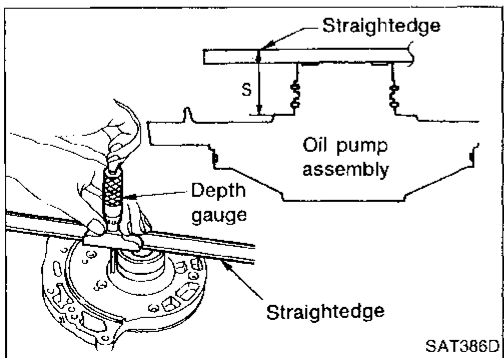

- b. Measure dimension "S".
- c. Calculate dimension "Q".

**"Q": Distance between transmission case fitting surface and thrust washer mating surface.**  

$$Q = R - S$$

GI

MA

EM

LC

EF &  
EC

FE

CL

MT

AT

FA

RA

BR

ST

BF

HA

EL

IOX

# SERVICE DATA AND SPECIFICATIONS (SDS)

## Specifications and Adjustments

### VEHICLE SPEED WHEN SHIFTING GEARS

#### — RL4F03A —

Throttle position	Vehicle speed km/h (MPH)						
	D <sub>1</sub> → D <sub>2</sub>	D <sub>2</sub> → D <sub>3</sub>	D <sub>3</sub> → D <sub>4</sub>	D <sub>4</sub> → D <sub>3</sub>	D <sub>3</sub> → D <sub>2</sub>	D <sub>2</sub> → D <sub>1</sub>	1 <sub>2</sub> → 1 <sub>1</sub>
Full throttle	51 - 59 (32 - 37)	97 - 105 (60 - 65)	—	149 - 157 (93 - 98)	88 - 96 (55 - 60)	39 - 47 (24 - 29)	48 - 56 (30 - 35)
Half throttle	28 - 36 (17 - 22)	50 - 58 (31 - 36)	97 - 105 (60 - 65)	62 - 70 (39 - 43)	40 - 48 (25 - 30)	8 - 16 (5 - 10)	48 - 56 (30 - 35)

#### — RE4F03V —

Throttle position	Shift pattern	Vehicle speed km/h (MPH)						
		D <sub>1</sub> → D <sub>2</sub>	D <sub>2</sub> → D <sub>3</sub>	D <sub>3</sub> → D <sub>4</sub>	D <sub>4</sub> → D <sub>3</sub>	D <sub>3</sub> → D <sub>2</sub>	D <sub>2</sub> → D <sub>1</sub>	1 <sub>2</sub> → 1 <sub>1</sub>
Full throttle	Comfort	54 - 62 (34 - 39)	103 - 111 (64 - 69)	164 - 172 (102 - 107)	160 - 168 (99 - 104)	93 - 101 (58 - 63)	41 - 49 (25 - 30)	54 - 62 (34 - 39)
	Power	54 - 62 (34 - 39)	103 - 111 (64 - 69)	164 - 172 (102 - 107)	160 - 168 (99 - 104)	93 - 101 (58 - 63)	41 - 49 (25 - 30)	54 - 62 (34 - 39)
Half throttle	Comfort	28 - 36 (17 - 22)	62 - 70 (39 - 43)	106 - 114 (66 - 71)	58 - 66 (36 - 41)	35 - 43 (22 - 27)	9 - 17 (6 - 11)	54 - 62 (34 - 39)
	Power	31 - 39 (19 - 24)	69 - 77 (43 - 48)	116 - 124 (72 - 77)	92 - 100 (57 - 62)	40 - 48 (25 - 30)	9 - 17 (6 - 11)	54 - 62 (34 - 39)

### VEHICLE SPEED WHEN PERFORMING LOCK-UP

#### — RL4F03A —

Throttle opening	Gear position	Vehicle speed km/h (MPH)	
		Lock-up "ON"	Lock-up "OFF"
2/8	D <sub>4</sub>	66 - 74 (41 - 46)	62 - 70 (39 - 43)

#### — RE4F03V —

Throttle opening	OD switch	Shift pattern	Vehicle speed km/h (MPH)	
			Lock-up "ON"	Lock-up "OFF"
2/8	ON (D <sub>4</sub> )	Comfort	82 - 90	61 - 69
		Power	(51 - 56)	(38 - 43)
	OFF (D <sub>3</sub> )	Comfort	86 - 94	83 - 91
		Power	(53 - 58)	(52 - 57)

### STALL REVOLUTION

Engine	Stall revolution rpm
GA16DE	2,450 - 2,750
SR20DE	1,850 - 2,150

### THROTTLE WIRE ADJUSTMENT

#### — RL4F03A —

Throttle wire stroke	mm (in)
	40 - 42 (1.57 - 1.65)

### LINE PRESSURE

#### — RL4F03A —

Engine speed rpm	Line pressure kPa (kg/cm <sup>2</sup> , psi)			
	R position	D position	2 position	1 position
Idle	883 (9.0, 128)	539 (5.5, 78)	775 (7.9, 112)	775 (7.9, 112)
Stall	1,765 (18.0, 256)	1,079 (11.0, 156)	1,079 (11.0, 156)	1,079 (11.0, 156)

#### — RE4F03V —

Engine speed rpm	Line pressure kPa (kg/cm <sup>2</sup> , psi)			
	R position	D position	2 position	1 position
Idle	853 (8.7, 124)	500 (5.1, 73)	500 (5.1, 73)	500 (5.1, 73)
Stall	1,863 (19.0, 270)	1,098 (11.2, 159)	1,098 (11.2, 159)	1,098 (11.2, 159)

## Precautions

- When removing or installing various parts, place a cloth or padding onto the vehicle body to prevent scratches.
- Handle trim, molding, instruments, grille, etc. carefully during removing or installation. Be careful not to soil or damage them.
- Apply sealing compound where necessary when installing parts.
- When applying sealing compound, be careful that the sealing compound does not protrude from parts.
- When replacing any metal parts (for example body outer panel, members, etc.), be sure to take rust prevention measures.

## Supplemental Restraint System "AIR BAG"

The Supplemental Restraint System "Air Bag" helps to reduce the risk or severity of injury to the driver in a frontal collision. The Supplemental Restraint System consists of an air bag (located in the center of the steering wheel), sensors, a diagnosis unit, warning lamp, wiring harness and spiral cable. Information necessary to service the system safely is included in the BF section of this Service Manual.

### WARNING:

- To avoid rendering the SRS inoperative, which could lead to personal injury or death in the event of a severe frontal collision, all maintenance must be performed by an authorized NISSAN dealer.
- Improper maintenance, including incorrect removal and installation of the SRS, can lead to personal injury caused by unintentional activation of the system.
- All SRS electrical wiring harnesses and connectors are covered with yellow outer insulation. Do not use electrical test equipment on any circuit related to the SRS "Air Bag".

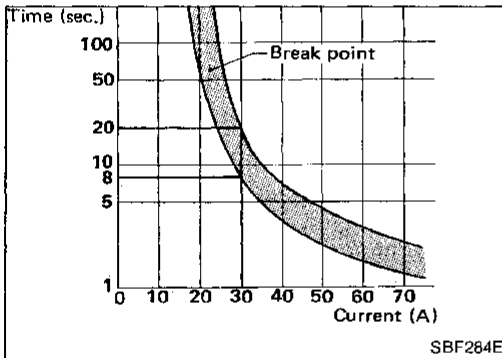

### Circuit Breaker Inspection



For example, when current is 30A, the circuit is broken within 8 to 20 seconds.

Circuit breakers are used in the following systems.

- Power window & power door lock
- Power sun roof

### Clip and Fastener

- Clips and fasteners in BF section correspond to the following numbers and symbols.
- Replace any clips and/or fasteners which are damaged during removal or installation.

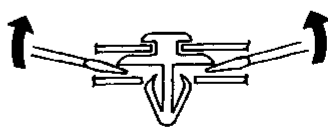
Symbol No.	Shapes	Removal & Installation
		<p><b>Removal:</b> Remove by bending up with flat-bladed screwdrivers.</p> 
	SBF256G	SBF367B

**Harness Layout**

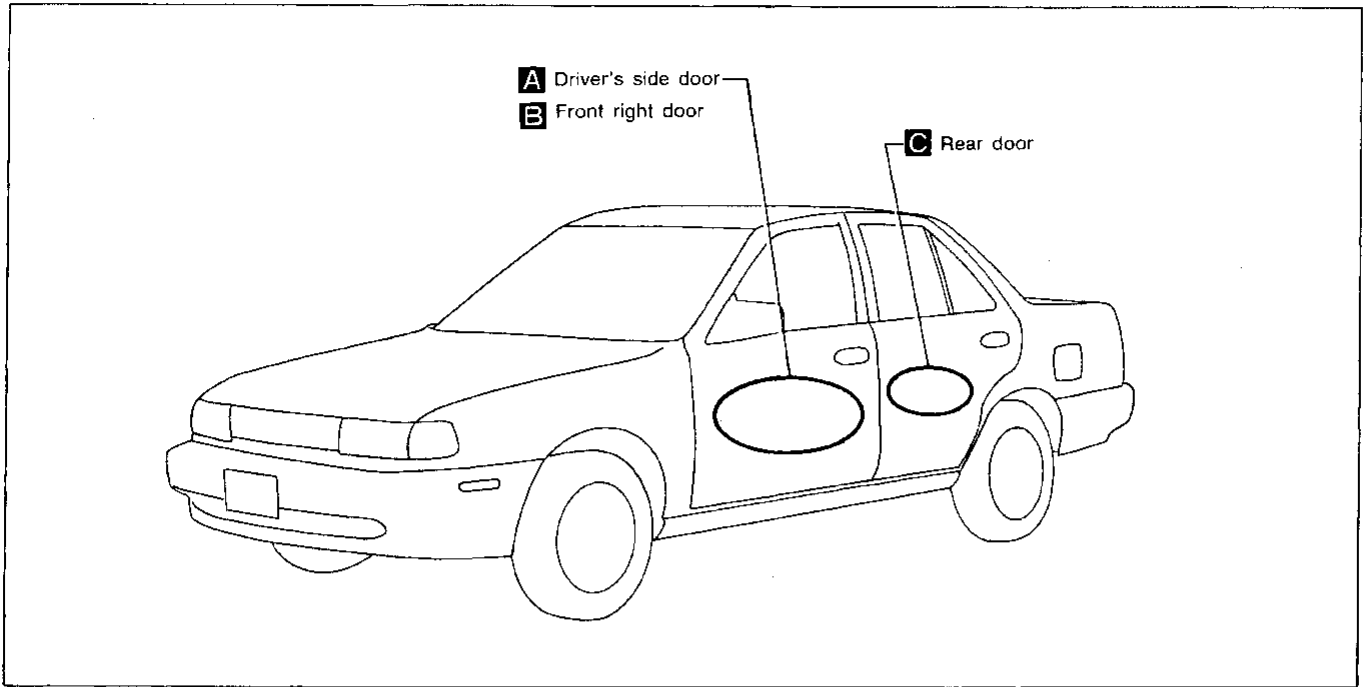

GI  
 MA  
 EM  
 LC  
 EF &  
 EC  
 FE  
 CL  
 MT  
 AT  
 FA  
 RA  
 BR  
 ST  
 BF  
 HA  
 EL  
 DX

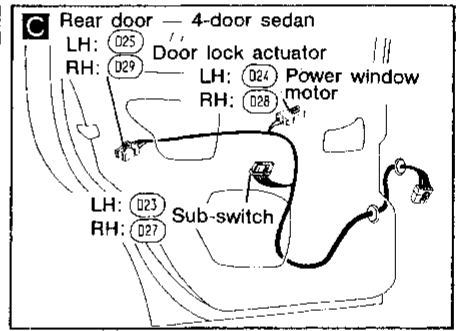
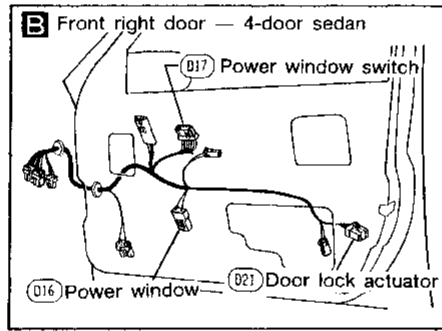
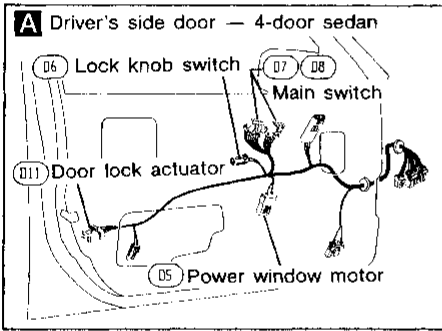

# INTERIOR AND EXTERIOR

## Interior (Cont'd)

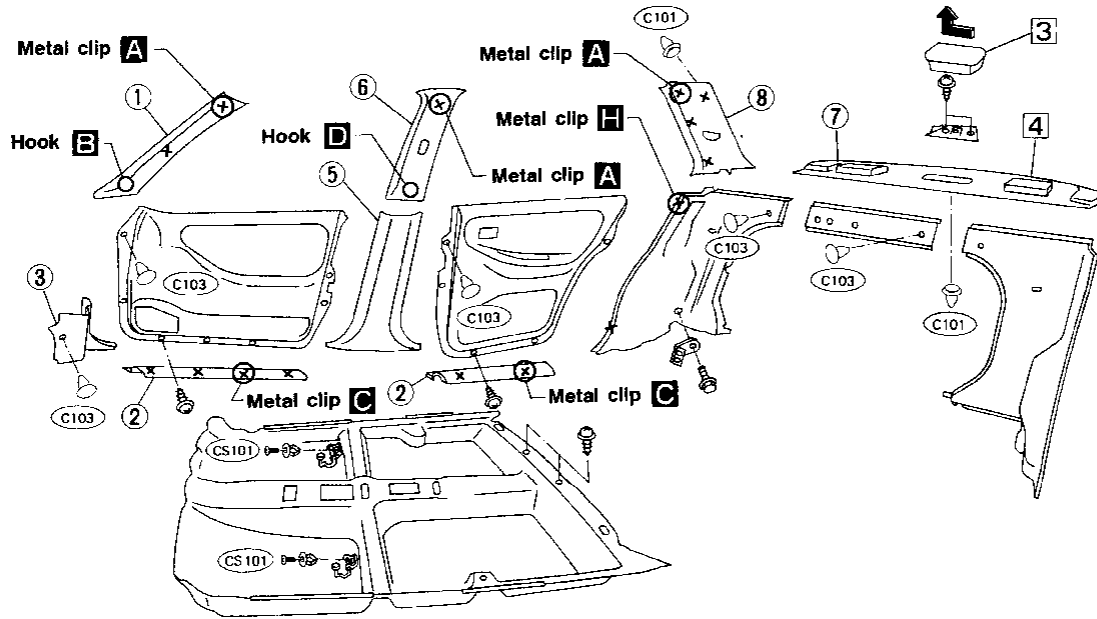

Models with 2-point motorized automatic seat bolt

2-door Sedan

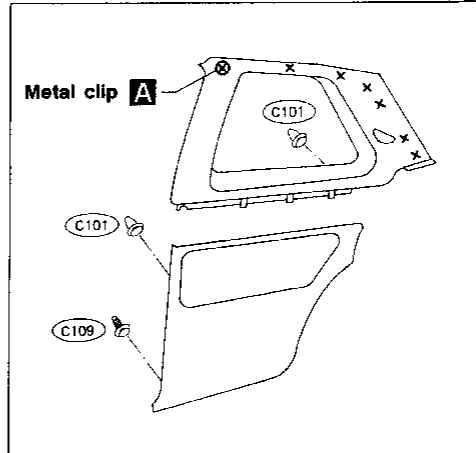
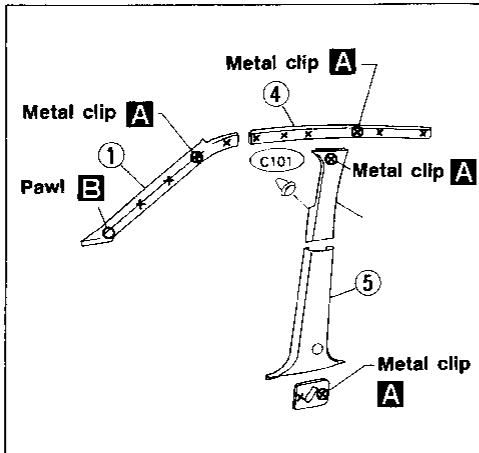

Front door trim

Rear door trim

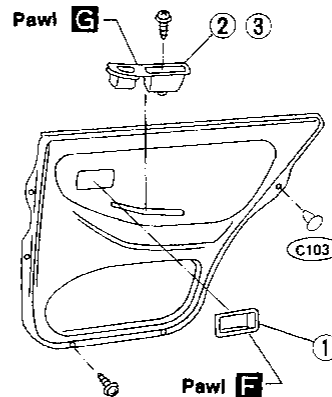
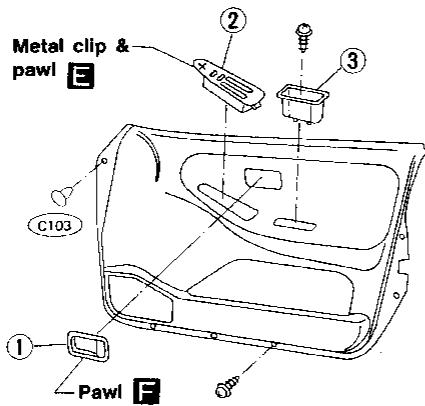

# 3-POINT FIXED AUTOMATIC SEAT BELT SYSTEM — 2-door Sedan

## Wiring Diagram

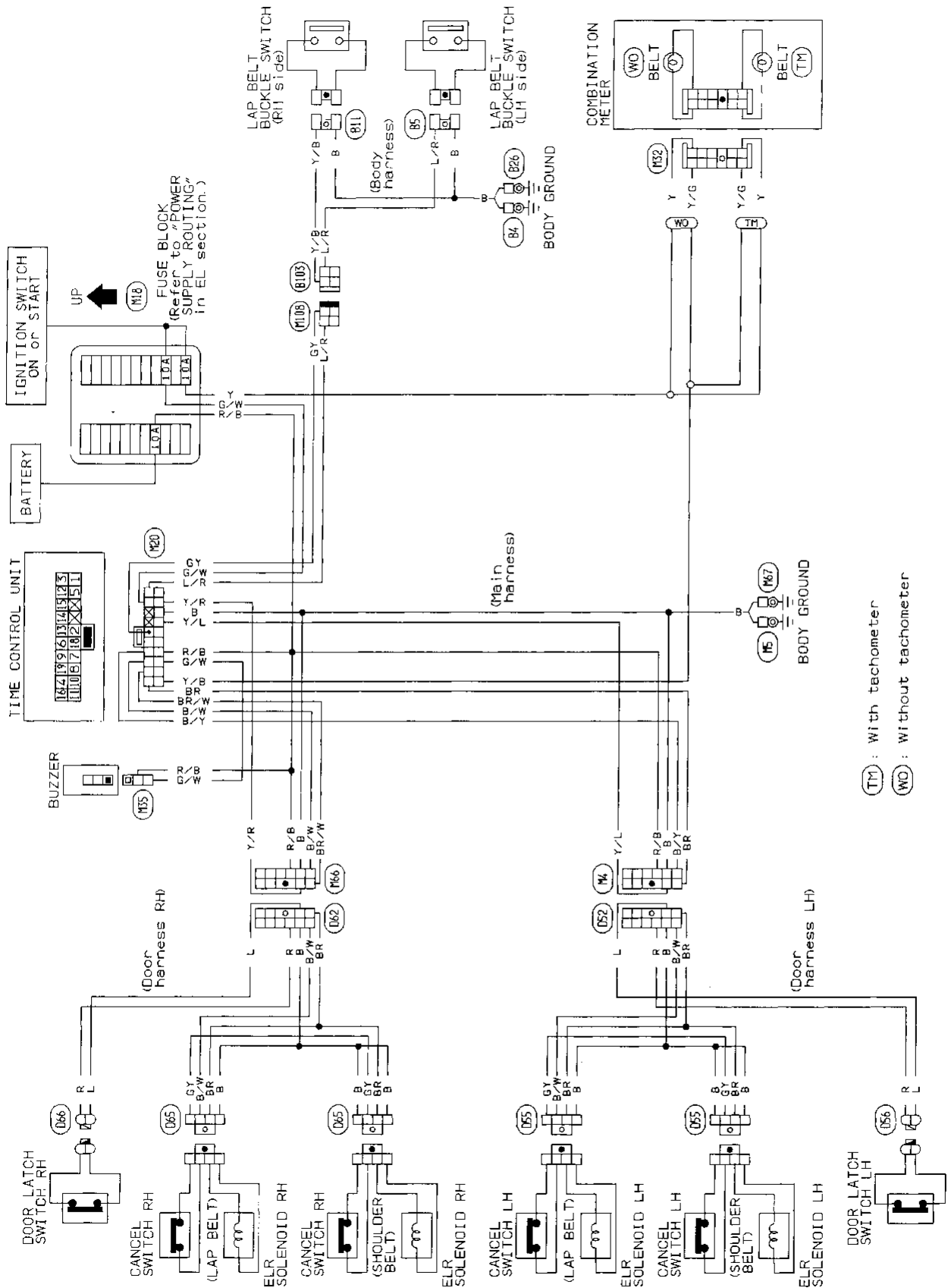

MBF234B

### Contents

<b>Symptom Chart</b> .....	BF-55
<b>Preliminary Check</b> .....	BF-56
<b>Main Power Supply and Ground Circuit Check</b> .....	BF-59
<b>Harness Layout</b> .....	BF-60
<b>Circuit Diagram for Quick Pinpoint Check</b> .....	BF-61
<b>Diagnostic Procedure 1</b> (Check motor circuit and stop signals.).....	BF-62
<b>Diagnostic Procedure 2</b> (Check door latch switch circuit.).....	BF-64
<b>Diagnostic Procedure 3</b> (Check front limit switch circuit.) .....	BF-65
<b>Diagnostic Procedure 4</b> (Check rear limit switch circuit.).....	BF-66
<b>Diagnostic Procedure 5</b> (Check shoulder belt buckle switch circuit.) .....	BF-68
<b>Diagnostic Procedure 6</b> (Check lap belt switch circuit.).....	BF-69
<b>Diagnostic Procedure 7</b> (Check warning buzzer circuit) .....	BF-71
<b>Diagnostic Procedure 8</b> (Check warning lamp circuit.) .....	BF-72
<b>Diagnostic Procedure 9</b> (Check shoulder belt locking canceler circuit.).....	BF-73
<b>Electrical Components Inspection</b> .....	BF-74

Since left and right component parts are basically the same, harness layout and methods for electrical components inspection are shown for one side only.

For those methods enclosed by double rectangles, component parts on both sides must be checked.

# 2-POINT MOTORIZED AUTOMATIC SEAT BELT SYSTEM — Trouble Diagnoses

## Diagnostic Procedure 4 (Cont'd)

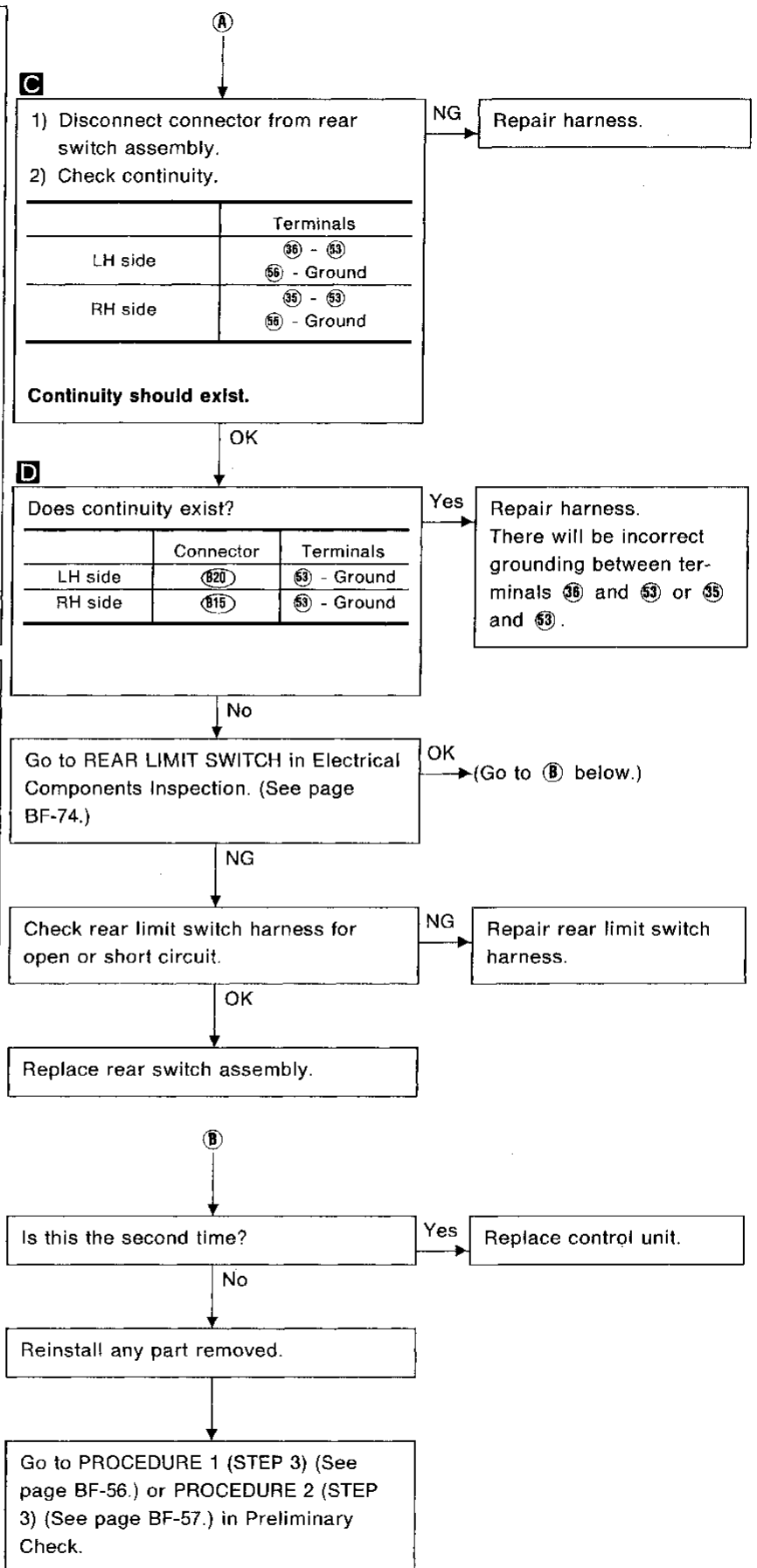
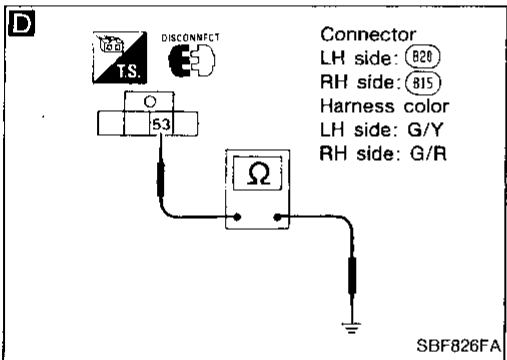
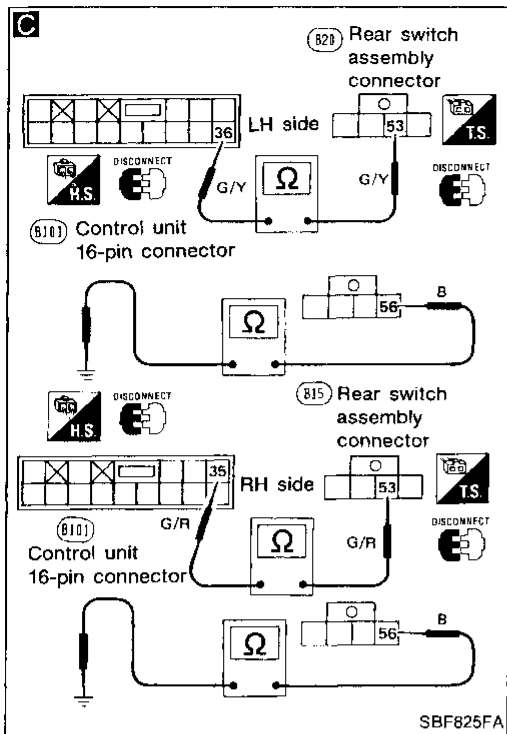

GI

WA

EM

LC

EF &  
EC

FE

CL

MT

AT

FA

RA

BR

ST

BF

HA

EL

IDX

# MIRROR

## Door Mirror

### REMOVAL

- Wrap flat-bladed screwdriver with a cloth to prevent scratching rear of door mirror. Do not insert screwdriver too far.

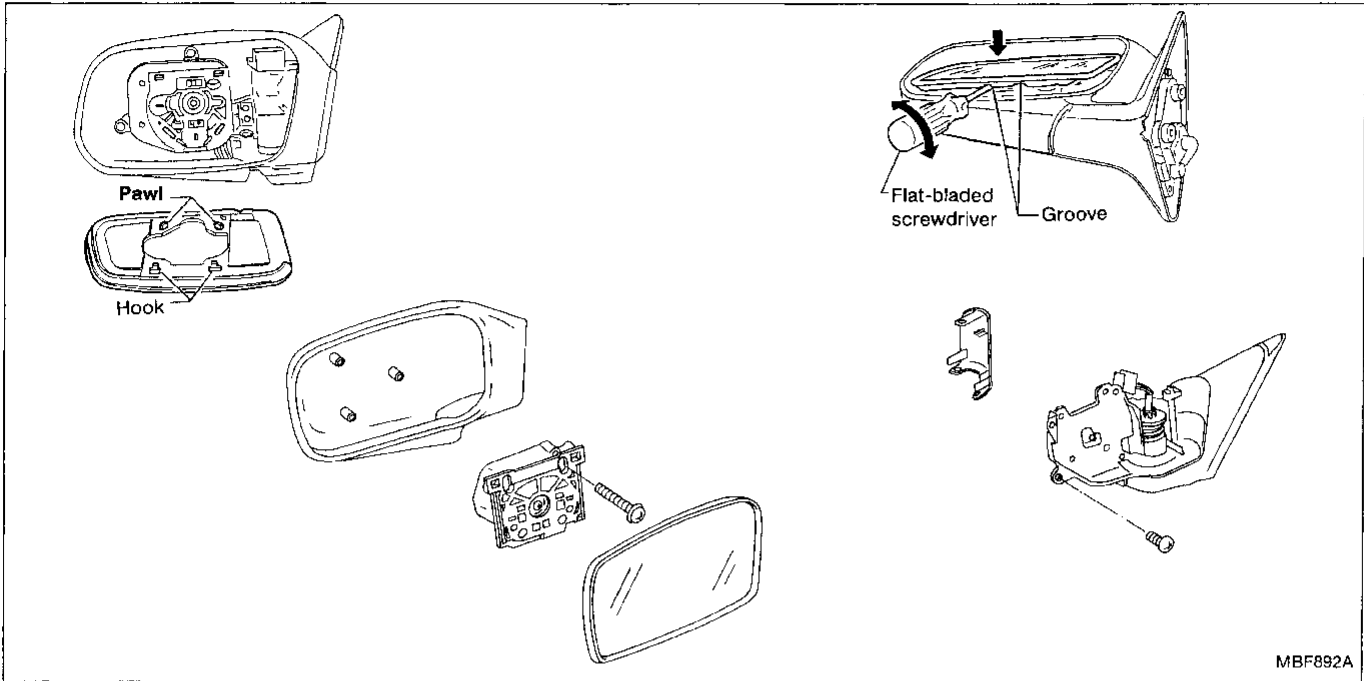

MBF892A

### WIRING DIAGRAM

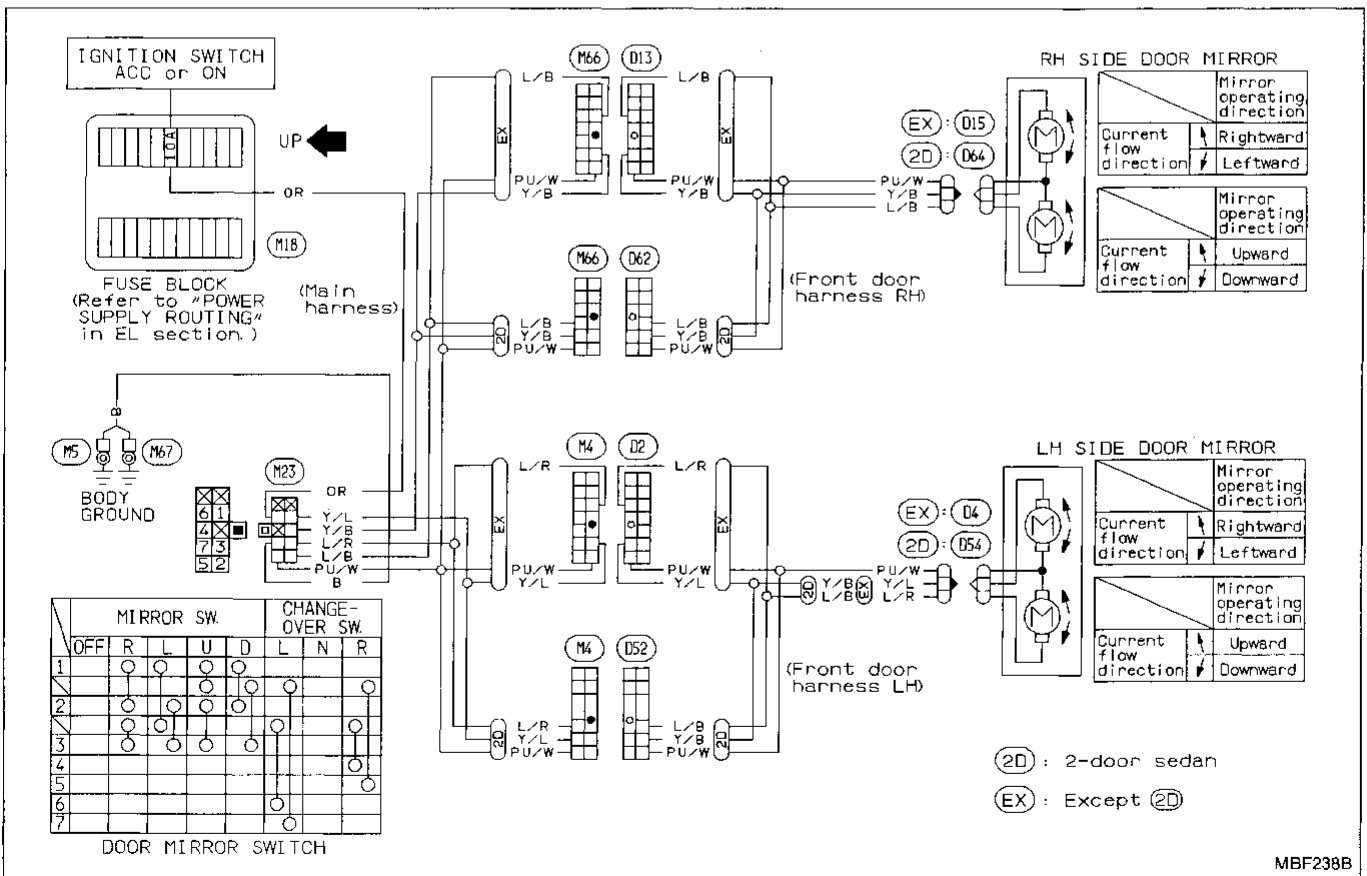

MBF238B

# SUPPLEMENTAL RESTRAINT SYSTEM (SRS)

## Removal — Air Bag Module and Spiral Cable

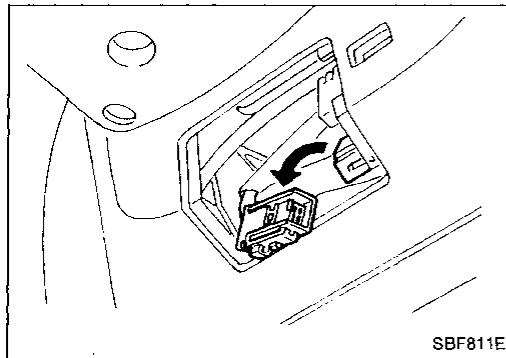
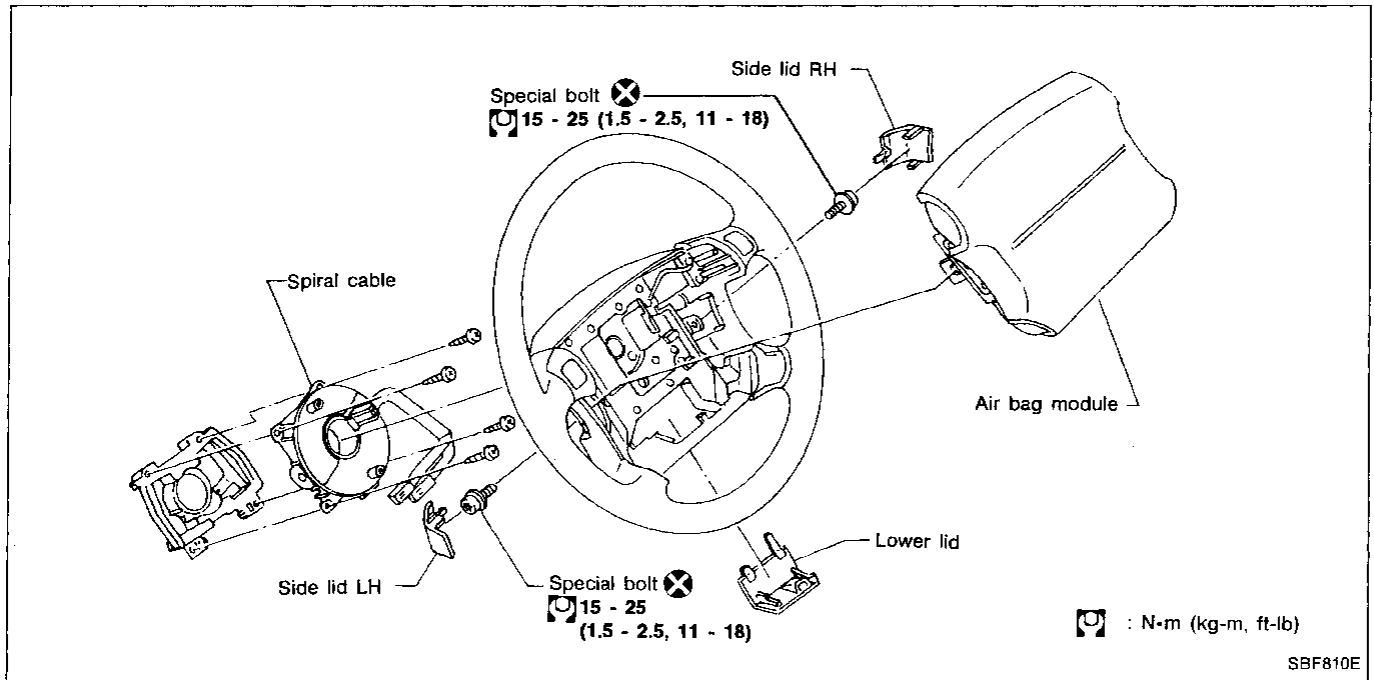

### CAUTION:

Before servicing SRS, turn the ignition switch off, disconnect battery ground cable and wait for at least 10 minutes.

1. Remove lower lid from steering wheel, and disconnect air bag module connector.

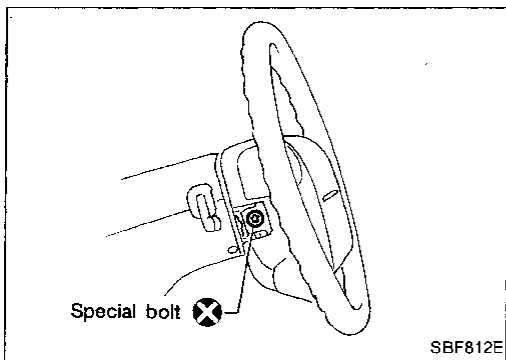

2. Remove side lid. Using the T50H torx bit, remove left and right special bolts. Air bag module can then be removed.

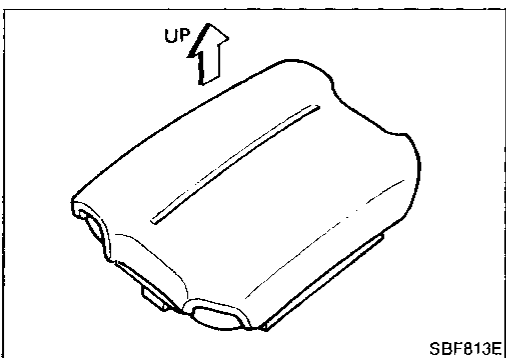

### CAUTION:

- Always place air bag module with pad side facing upward.
- Do not attempt to disassemble air bag module.
- The special bolts are coated with bonding agent. Discard old ones after removal; replace with new ones.

## Diagnostic Procedure 3

**SYMPTOM: Warning lamp does not go off.**

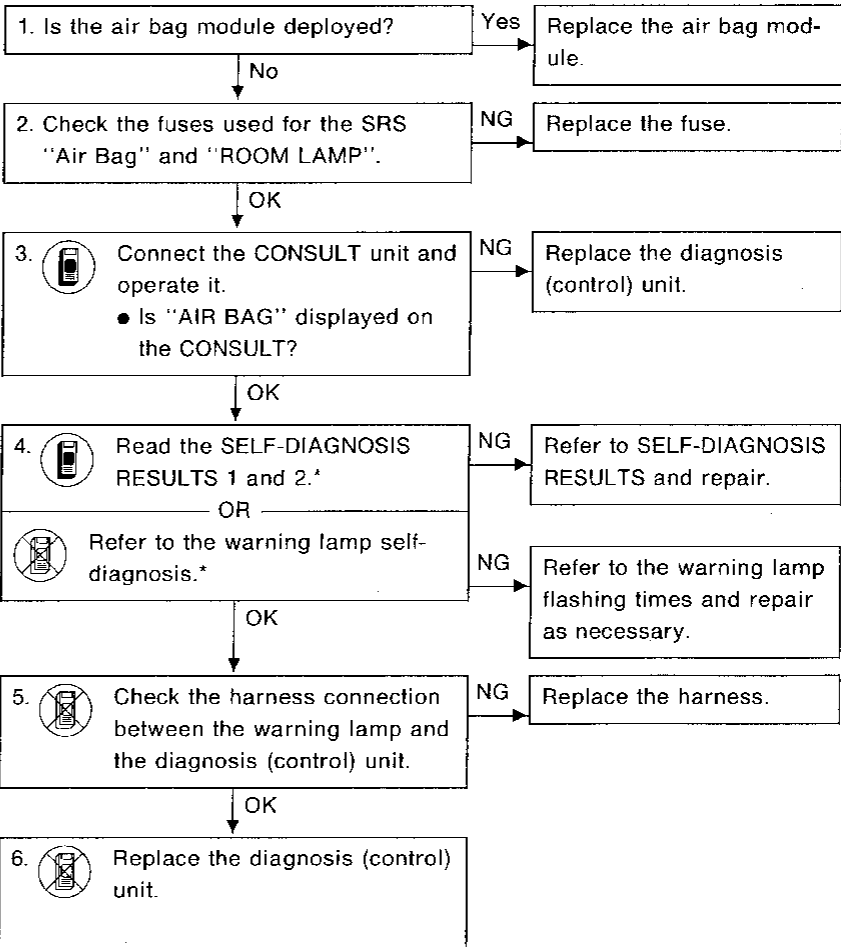
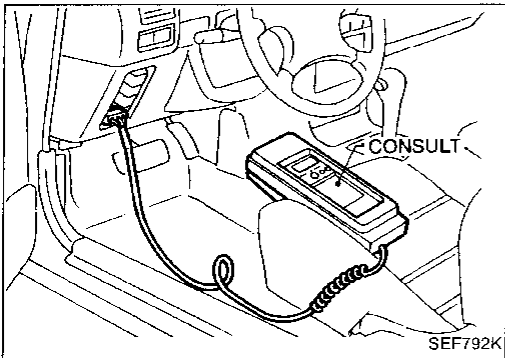
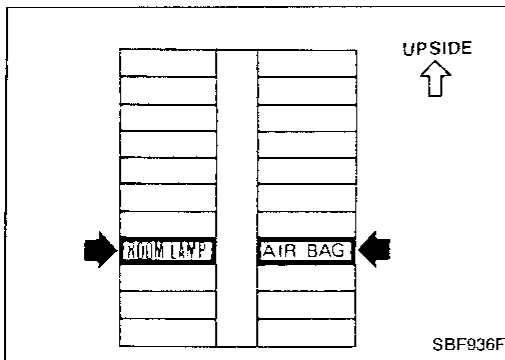

\* Recheck SRS after each replacement.

# BRAKE BOOSTER/VACUUM HOSE

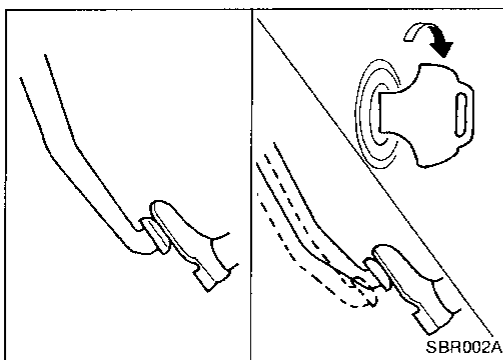

SBR002A

## Brake Booster

### ON-VEHICLE SERVICE

#### Operating check

- Depress brake pedal several times with engine off, and check that there is no change in pedal stroke.
- Depress brake pedal, then start engine. If pedal goes down slightly, operation is normal.

#### Airtight check

- Start engine, and stop it after one or two minutes. Depress brake pedal several times slowly. If pedal goes further down the first time and gradually rises after second or third time, booster is airtight.
- Depress brake pedal while engine is running, and stop engine with pedal depressed. If there is no change in pedal stroke after holding pedal down **30 seconds**, brake booster is airtight.

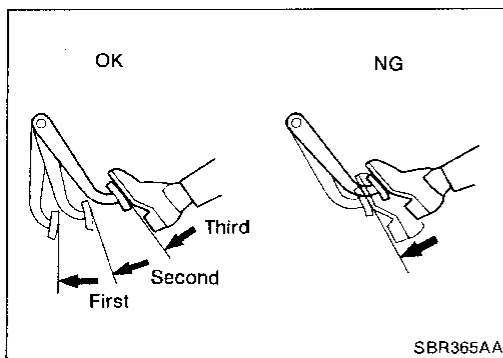

SBR365AA

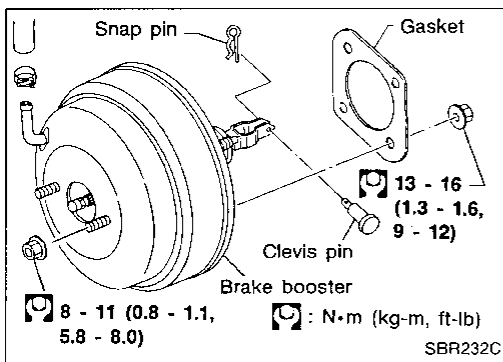

SBR232C

### REMOVAL

#### CAUTION:

- Be careful not to splash brake fluid on painted areas; it may cause paint damage. If brake fluid is splashed on painted areas, wash it away with water immediately.
- Be careful not to deform or bend brake pipes, during removal of booster.

### INSPECTION

#### Output rod length check

1. Apply vacuum of  $-66.7 \text{ kPa}$  ( $-500 \text{ mmHg}$ ,  $-19.69 \text{ inHg}$ ) to brake booster with a handy vacuum pump.
2. Check output rod length.

#### Specified length:

**M20**

4.875 - 5.125 mm (0.1919 - 0.2018 in)

**M165T, M195T**

10.275 - 10.525 mm (0.4045 - 0.4144 in)

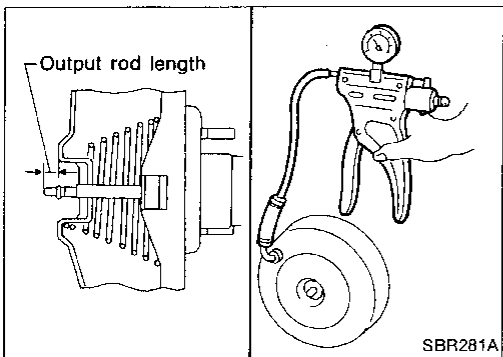

SBR281A

### INSTALLATION

#### CAUTION:

- Be careful not to deform or bend brake pipes, during installation of booster.
- Replace clevis pin if damaged.
- Refill with new brake fluid "DOT 3".
- Never reuse drained brake fluid.
- Take care not to damage brake booster mounting bolt thread when installing. Due to the acute angle of installation, the threads can be damaged on the metal surrounding the dash panel holes.

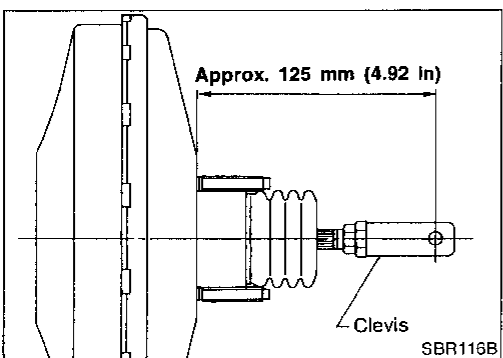

SBR116B

# REAR DRUM BRAKE

## Removal (Cont'd)

b. Tighten the two bolts gradually.

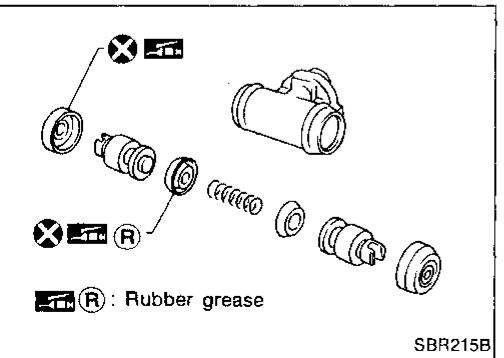
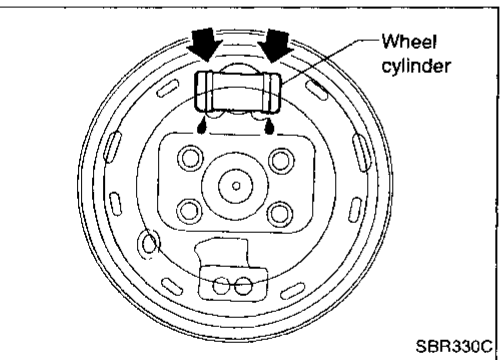
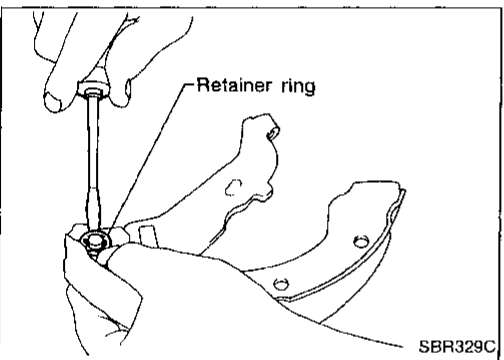
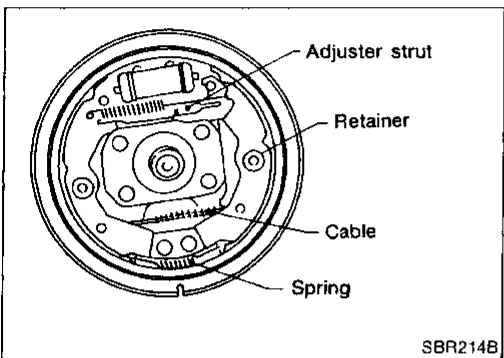
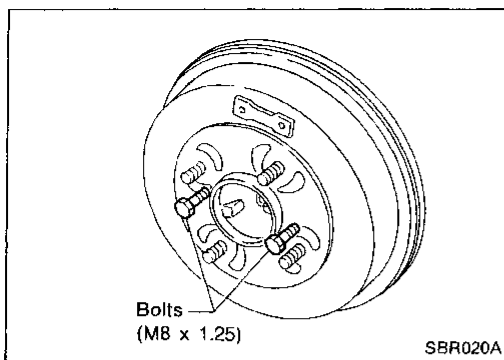

2. After removing retainer, remove spring by rotating shoes. **Be careful not to damage parking brake cable when separating it.**

3. Remove adjuster.

4. Disconnect parking brake cable from toggle lever.

5. Remove retainer ring with a suitable tool. Then separate toggle lever and brake shoe.

## Inspection — Wheel Cylinder

- Check wheel cylinder for leakage.
- Check for wear, damage and loose conditions. Replace if any such condition exists.

## Wheel Cylinder Overhaul

Pay attention so as not to scratch cylinder when installing pistons.

GI

MA

EM

LC

EF &  
EC

FE

CL

MT

AT

FA

RA

**BR**

ST

BF

HA

EL

IDX

# TROUBLE DIAGNOSES

---

## Contents

How to Perform Trouble Diagnoses for Quick and Accurate Repair .....	BR-39
Symptom Chart .....	BR-42
Preliminary Check .....	BR-43
Self-diagnosis .....	BR-44
Component Parts and Harness Connector Location .....	BR-45
Ground Circuit Check .....	BR-47
Circuit Diagram for Quick Pinpoint Check .....	BR-47
Diagnostic Procedure 1 — Pedal vibration and noise .....	BR-48
Diagnostic Procedure 2 — Long stopping distance .....	BR-50
Diagnostic Procedure 3 — Unexpected pedal action .....	BR-50
Diagnostic Procedure 4 — ABS does not work .....	BR-51
Diagnostic Procedure 5 — ABS works but warning activates .....	BR-51
Diagnostic Procedure 6 — ABS works frequently .....	BR-51
Diagnostic Procedure 7 — Warning never activates .....	BR-52
Diagnostic Procedure 8 — ACTUATOR SOLENOID (LED flashing number 1 - 3) .....	BR-53
Diagnostic Procedure 9 — WHEEL SPEED SENSOR (LED flashing number 5 - 8) .....	BR-54
Diagnostic Procedure 10 — ACTUATOR MOTOR RELAY (LED flashing number 9) .....	BR-55
Diagnostic Procedure 11 — ACTUATOR SOLENOID VALVE RELAY (LED flashing number 10) ....	BR-57
Diagnostic Procedure 12 — SENSOR AND SENSOR ROTOR (LED flashing number 15) .....	BR-58
Diagnostic Procedure 13 — CONTROL UNIT (LED flashing number 16) .....	BR-58
Diagnostic Procedure 14 — CONTROL UNIT OR POWER SUPPLY AND GROUND CIRCUIT (Warning activates but LED comes off) .....	BR-59
Electrical Components Inspection .....	BR-60

**Diagnostic Procedure 4**

**SYMPTOM: ABS does not work.**

Refer to worksheet results. (See page BR-41.)

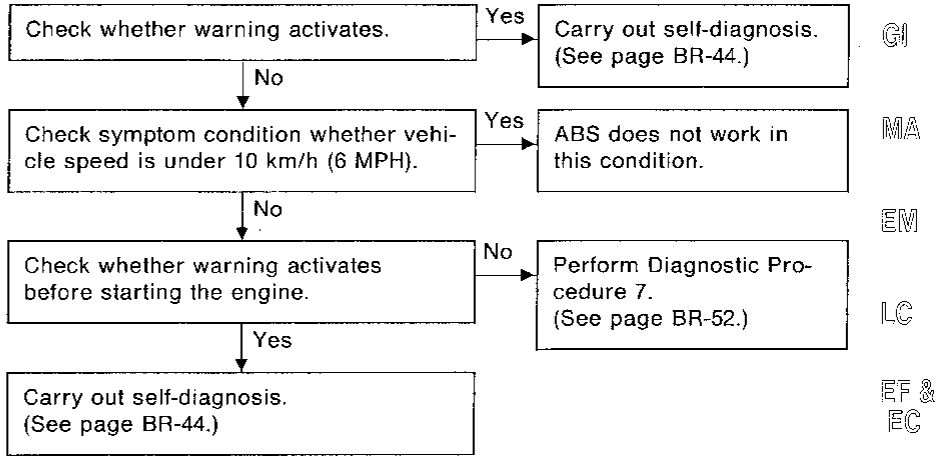

**Diagnostic Procedure 5**

**SYMPTOM: ABS works but warning activates.**

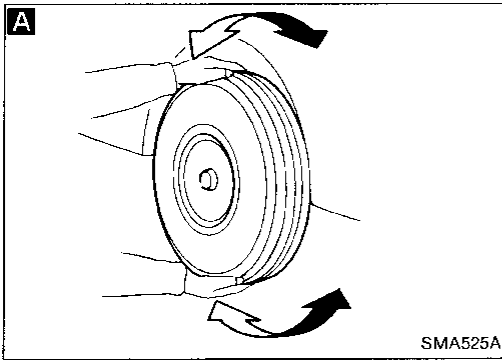
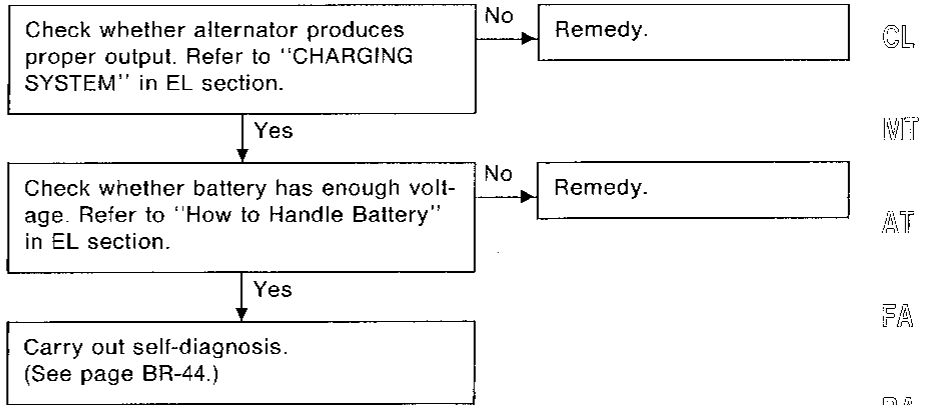

**Diagnostic Procedure 6**

**SYMPTOM: ABS works frequently.**

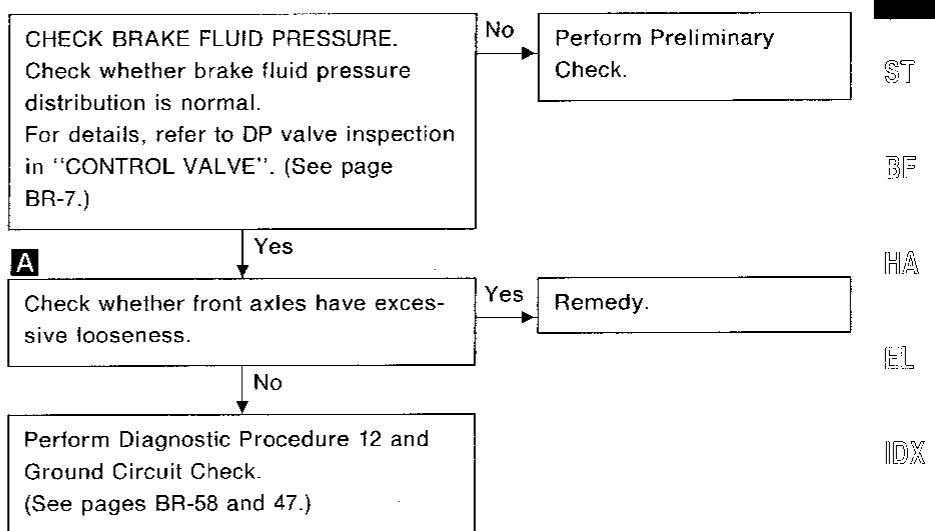

# PRECAUTION AND PREPARATION

## Precaution

### WARNING:

After cleaning the clutch disc, wipe it with a dust collector. Do not use compressed air.

## Special Service Tools

\*: Special tool or commercial equivalent

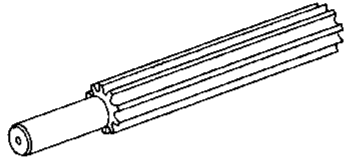
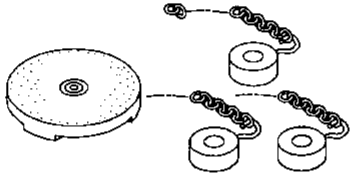
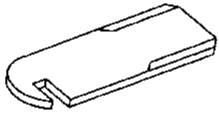
Tool number (Kent-Moore No.) Tool name	Description
KV30101000* (J33213) Clutch aligning bar	 <p>Installing clutch cover and clutch disc</p> <p>NT061</p>
ST20050010 ( — ) Base plate ST20050100 ( — ) Distance piece	 <p>Inspecting clutch cover diaphragm spring</p> <p>NT058</p>
ST20050240* ( — ) Diaphragm spring adjusting wrench	 <p>Adjusting unevenness of clutch cover diaphragm spring</p> <p>NT060</p>

ECCS Component Parts Location (Cont'd)

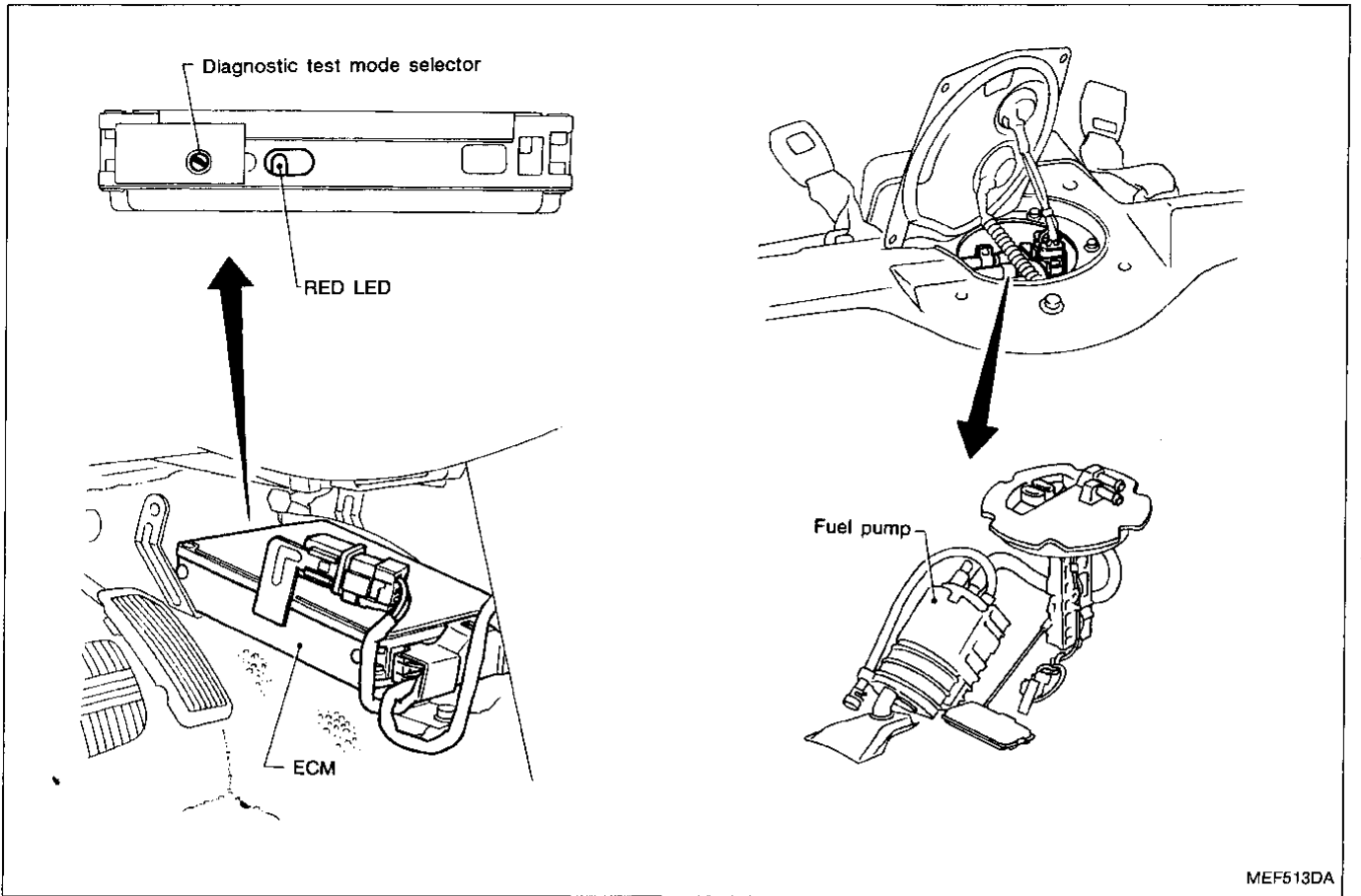

GI

MA

EM

LC

EF & EC

FE

CL

MT

AT

FA

RA

BR

ST

BF

HA

EL

IDX

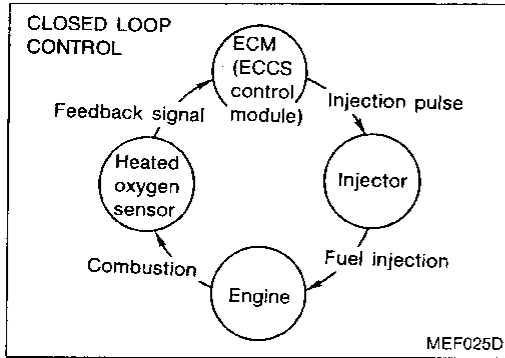

**Multiport Fuel Injection (MFI) System (Cont'd)**

**MIXTURE RATIO FEEDBACK CONTROL**

Mixture ratio feedback system is designed to precisely control the mixture ratio to the stoichiometric point so that the three way catalyst can reduce CO, HC and NOx emissions. This system uses an heated oxygen sensor in the exhaust manifold to check the air-fuel ratio. The ECM adjusts the injection pulse width according to the sensor voltage so the mixture ratio will be within the range of the stoichiometric air-fuel ratio. This stage refers to the closed loop control condition. The open loop control condition refers to that under which the ECM detects any of the following conditions and feedback control stops in order to maintain stabilized fuel combustion.

- 1) Deceleration
- 2) High-load operation
- 3) Engine idling
- 4) Malfunction of heated oxygen sensor or its circuit
- 5) Insufficient activation of heated oxygen sensor at low engine coolant temperature
- 6) Engine starting
- 7) Hot-engine operation
- 8) When all of the following conditions are met:
  - Ignition switch "ON"
  - Soft closed throttle position switch "ON"
  - Neutral position switch "OFF"
  - Engine running at idle speed
  - Vehicle running at slow speed

**MIXTURE RATIO SELF-LEARNING CONTROL**

The mixture ratio feedback control system monitors the mixture ratio signal transmitted from the heated oxygen sensor. This feedback signal is then sent to the ECM to control the amount of fuel injection to provide a basic mixture ratio as close to the theoretical mixture ratio as possible. However, the basic mixture ratio is not necessarily controlled as originally designed. This is due to manufacturing errors (e.g., mass air flow sensor hot wire) and changes during operation (injector clogging, etc.) of ECSS parts which directly affect the mixture ratio. Accordingly, a difference between the basic and theoretical mixture ratios is quantitatively monitored in this system. It is then computed in terms of "fuel injection duration" to automatically compensate for the difference between the two ratios.

**FUEL INJECTION TIMING**

Two types of fuel injection systems are used — simultaneous multiport fuel injection system and sequential multiport fuel injection system. In the former, fuel is injected into all four cylinders simultaneously twice each engine cycle.

In other words, pulse signals of the same width are simultaneously transmitted from the ECM to the four injectors two times for each engine cycle.

In the sequential multiport fuel injection system system, fuel is injected into each cylinder during each engine cycle according to the firing order.

When the engine is being started and/or if the fail-safe system (CPU of ECM) is operating, simultaneous multiport fuel injection system is used.

When the engine is running sequential multiport fuel injection system is used.

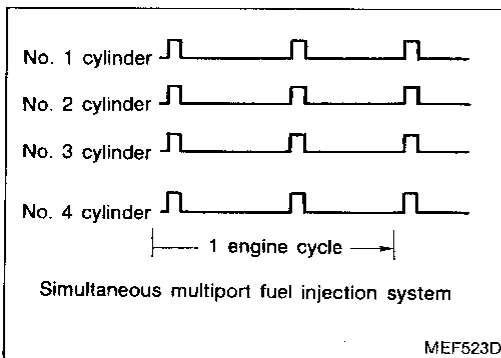
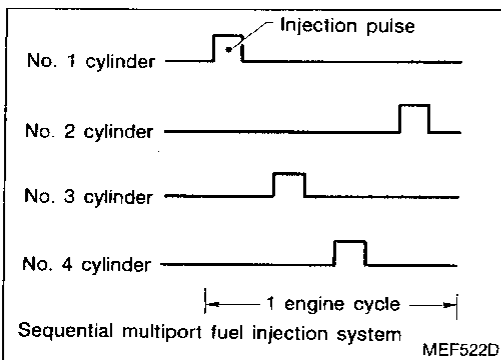

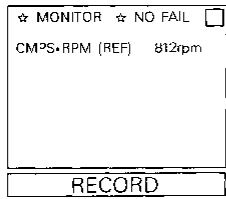

SEF550N

**Check idle speed.**

- Read idle speed in "DATA MONITOR" mode with CONSULT.
- OR
- Check idle speed.

**M/T: 800 ± 50 rpm**  
**A/T: 800 ± 50 rpm (in "N" position)**

OK

NG

Check IACV-AAC valve and replace if necessary.

Check IACV-AAC valve harness and repair if necessary.

Check ECM function\* by substituting another known good ECM.

\* ECM may be the cause of a problem, but this is rarely the case.

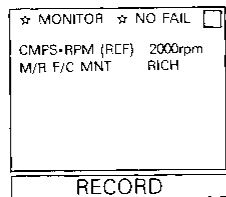

SEF551N

**1. See "M/R F/C MNT" in "Data monitor" mode.**

**2. Run engine at about 2,000 rpm for about 2 minutes under no-load.**

**3. Maintaining engine at 2,000 rpm under no-load (engine is warmed up sufficiently), check that the monitor fluctuates between "LEAN" and "RICH" more than 5 times during 10 seconds.**

**RICH → LEAN → RICH →**  
 1 time 2 times

**LEAN → RICH .....**

OR

**1. Set "Heated oxygen sensor monitor" in the diagnostic test mode II. (See page EF & EC-50.)**

**2. Run engine at about 2,000 rpm for about 2 minutes under no-load.**

**3. Maintaining engine at 2,000 rpm under no-load, check to make sure that the RED LED on the ECM or the malfunction indicator lamp on the instrument panel goes ON and OFF more than 5 times during 10 seconds.**

NG

Ⓢ

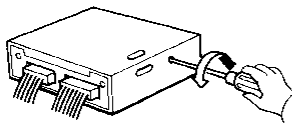

SEF957D

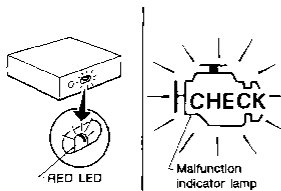

MEF377DA

OK

**END**

GI  
MA  
EM  
LC  
**EF & EC**  
FE  
CL  
MT  
AT  
FA  
RA  
BR  
ST  
BF  
HA  
EL  
IDX

## On-board Diagnostic System — Diagnostic Test Mode I

### DIAGNOSTIC TEST MODE I — BULB CHECK

In this mode, the RED LED in the ECM and the MALFUNCTION INDICATOR LAMP in the instrument panel stay "ON".

If either remain "OFF", check the bulb in the MALFUNCTION INDICATOR LAMP or the RED LED.

### DIAGNOSTIC TEST MODE I — MALFUNCTION WARNING

MALFUNCTION INDICATOR LAMP and RED LED	Condition
ON	When the following malfunctions (malfunction indicator lamp item) are detected or the ECM's CPU is malfunctioning.
OFF	OK

Diagnostic trouble code No.	Malfunction
12	Mass air flow sensor circuit
13	Engine coolant temperature sensor circuit
14	Vehicle speed sensor circuit
31	ECM (ECCS control module)
32	EGR function
33	Heated oxygen sensor circuit
35	EGR temperature sensor circuit
43	Throttle position sensor circuit
45	Injector leak

- These Diagnostic Trouble Code Numbers are clarified in Diagnostic Test Mode II — SELF-DIAGNOSTIC RESULTS.
- The RED LED and the MALFUNCTION INDICATOR LAMP will turn off when normal condition is detected. At this time, the Diagnostic Test Mode II — SELF-DIAGNOSTIC RESULTS memory must be cleared as the contents remain stored.

Consult (Cont'd)

FUNCTION TEST ITEM	CONDITION	JUDGEMENT	CHECK ITEM (REMEDY)
POWER BALANCE	<ul style="list-style-type: none"> <li>● After warming up, idle the engine.</li> <li>● Injector operation of each cylinder is stopped one after another, and resultant change in engine rotation is examined to evaluate combustion of each cylinder. (This is only displayed for models where a sequential multipoint fuel injection system system is used.)</li> </ul>	Difference in engine speed is greater than 25 rpm before and after cutting off the injector of each cylinder.	<ul style="list-style-type: none"> <li>● Injector circuit (Injector, harness or connector)</li> <li>● Ignition circuit (Spark plug, power transistor, ignition coil, harness or connector)</li> <li>● Compression</li> <li>● Valve timing</li> </ul>
IACV-AAC/V SYSTEM	<ul style="list-style-type: none"> <li>● After warming up, idle the engine.</li> <li>● IACV-AAC valve system is tested by detecting change in engine speed when IACV-AAC valve opening is changed to 0%, 20% and 80%.</li> </ul>	Difference in engine speed is greater than 150 rpm between when valve opening is at 80% (102 steps) and at 20% (25 steps).	<ul style="list-style-type: none"> <li>● Harness and connector</li> <li>● IACV-AAC valve</li> <li>● Air passage restriction between air inlet and IACV-AAC valve</li> <li>● IAS (Idle adjusting screw) adjustment</li> </ul>

GI  
MA  
EM  
LC  
EF & EC  
FE  
CL  
MT  
AT  
FA  
RA  
BR  
ST  
BF  
FA  
EL  
IDX



VEHICLE SPEED SENSOR (Diagnostic trouble code No. 14) <sup>HCHECK</sup>

(Malfunction indicator lamp item)

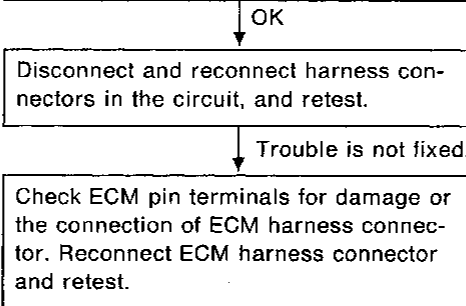
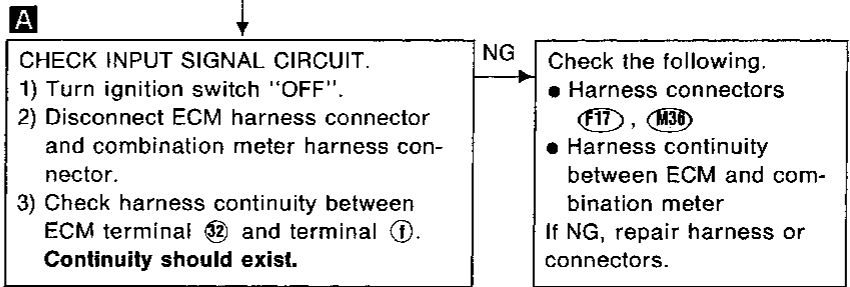
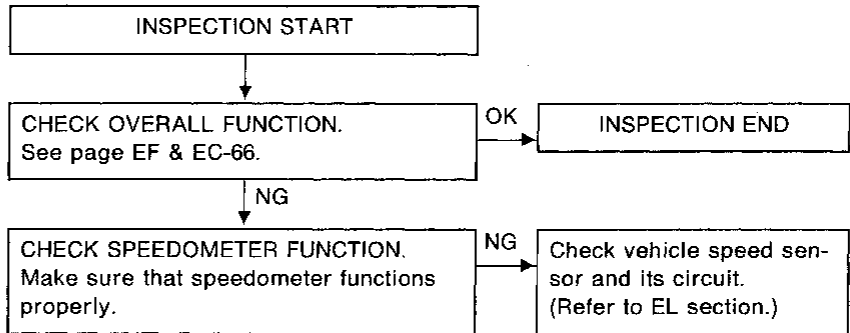
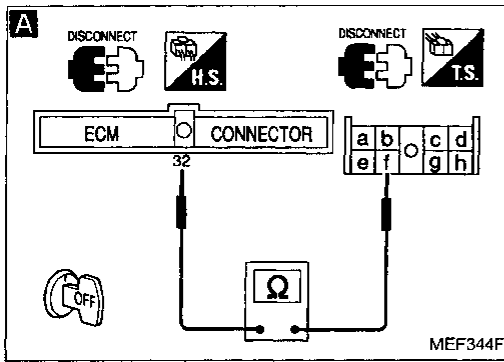

Perform FINAL CHECK by the following procedure after repair is completed.

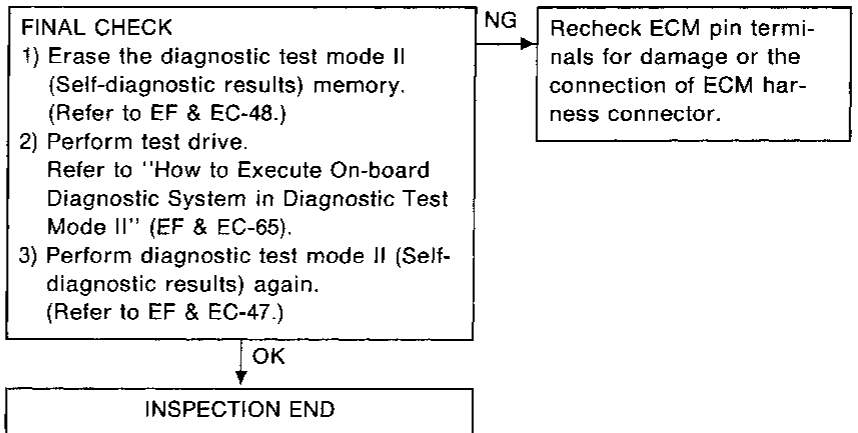

GI

MA

EM

LC

EF & EC

FE

CL

MT

AT

FA

RA

BR

ST

BF

HA

EL

IDX

Diagnostic Procedure 11

EGR TEMPERATURE SENSOR (Diagnostic trouble code No. 35)

 (Malfunction indicator lamp item)

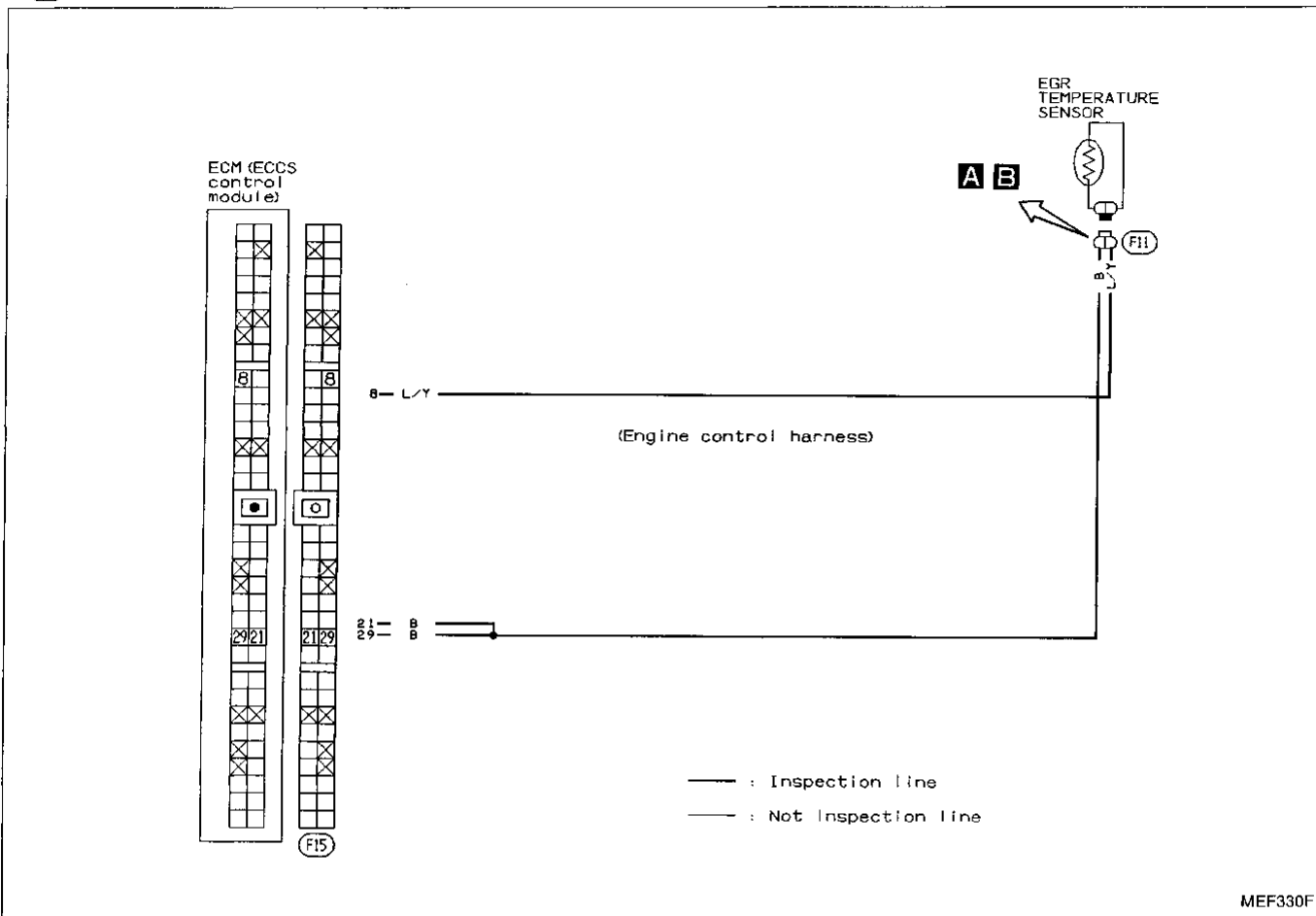

Harness layout

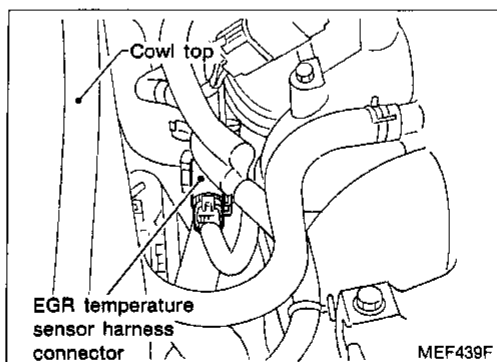
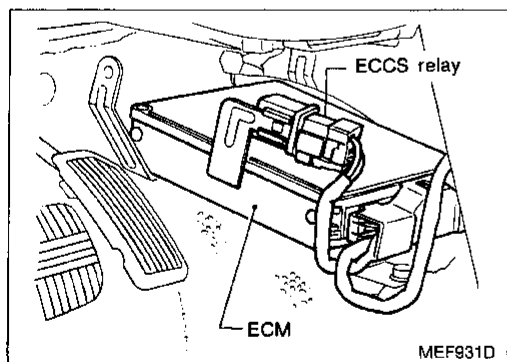

HEATED OXYGEN SENSOR HEATER (Not self-diagnostic item)

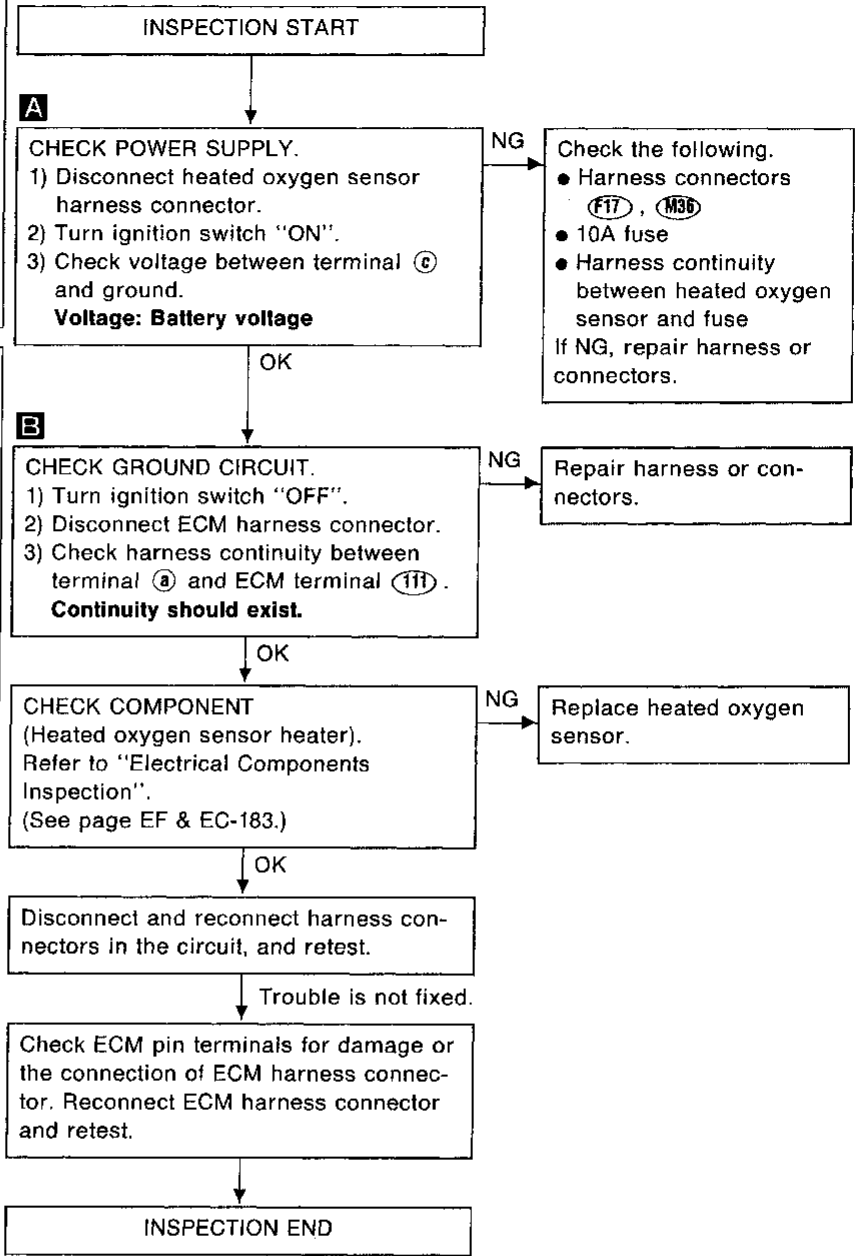
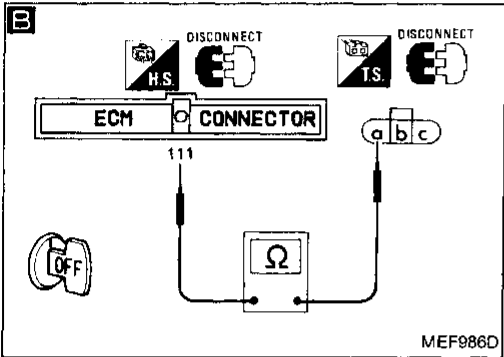
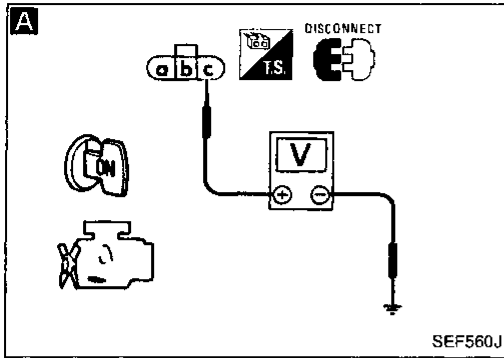

GI  
MA  
EM  
LC  
EF & EC  
FE  
CL  
MT  
AT  
FA  
RA  
BR  
ST  
BF  
HA  
EL  
IDX

Diagnostic Procedure 22

COOLING FAN CONTROL (Not self-diagnostic item)

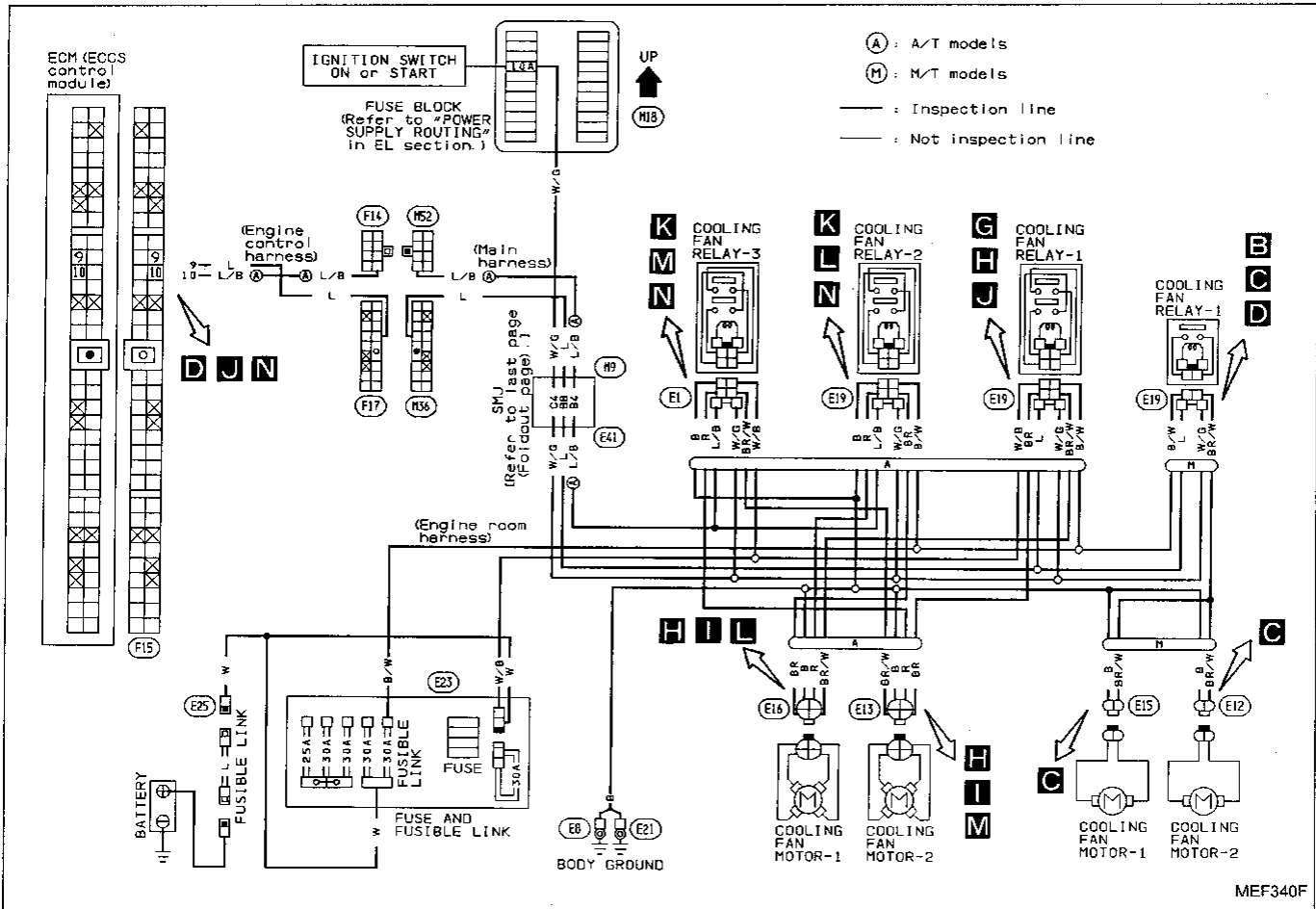

NEUTRAL POSITION/INHIBITOR SWITCH (Not self-diagnostic item)

**A**

■ NEUTRAL POSI SW CKT ■

SHIFT  
OUT OF N/P-RANGE  
THEN  
TOUCH START

NEXT START

MEF028E

**A**

☆ MONITOR ☆ NO FAIL

START SIGNAL	OFF
CLOSED TH/POS	ON
AIR COND SIG	OFF
NEUT POSI SW	ON

RECORD

MEF029E

**A**

DISCONNECT H.S.

ECM CONNECTOR

35

Ω

MEF030E

**B**

DISCONNECT T.S.

(a)

Ω

MEF363A

**C**

DISCONNECT H.S. DISCONNECT T.S.

ECM CONNECTOR

35

(b)

Ω

MEF031E

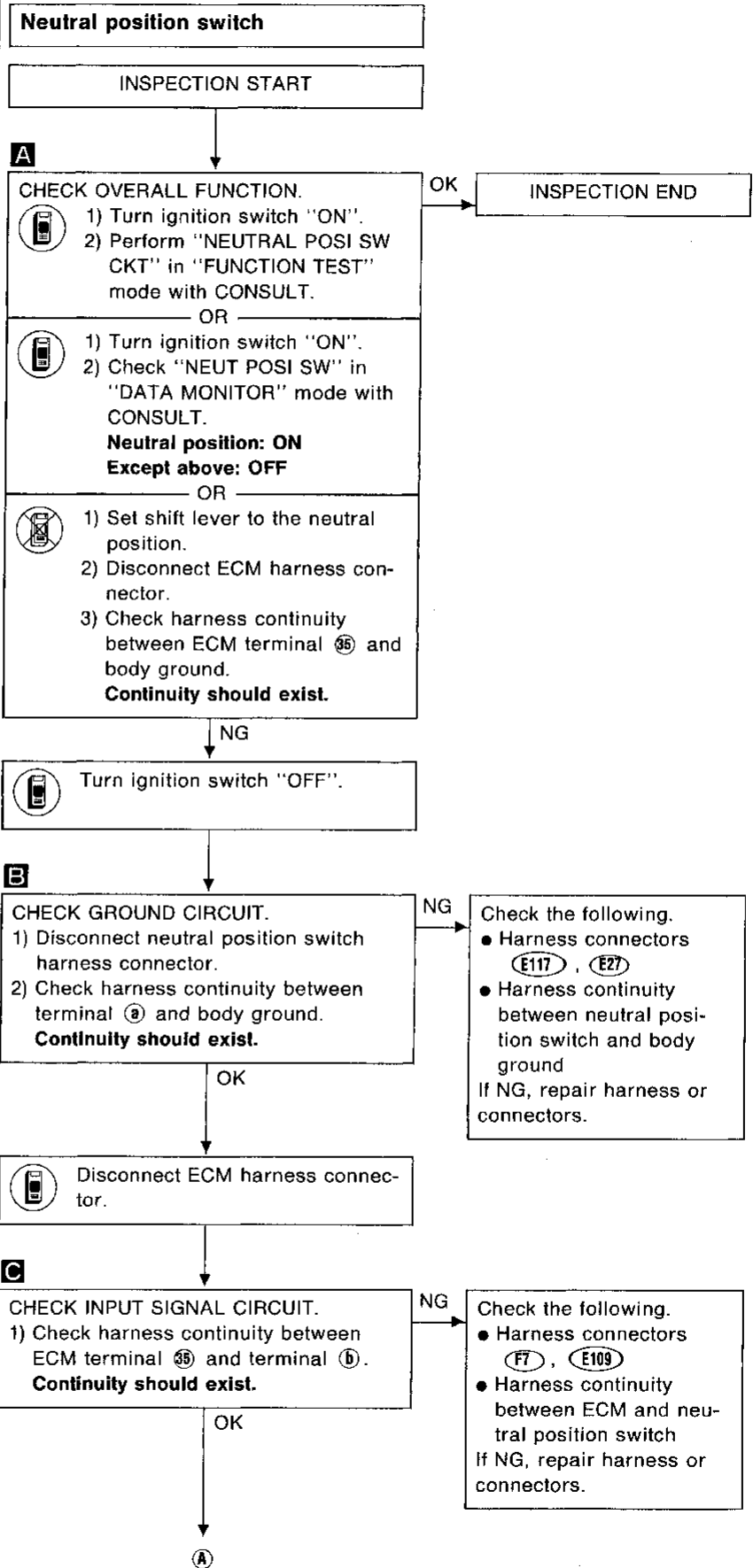

GI  
MA  
EM  
LC  
EF & EC  
FE  
CL  
MT  
AT  
FA  
RA  
BR  
ST  
BF  
HA  
EL  
IDX

**Diagnostic Procedure 29 — Symptom — Hard to Start or Impossible to Start when the Engine is Hot (Cont'd)**

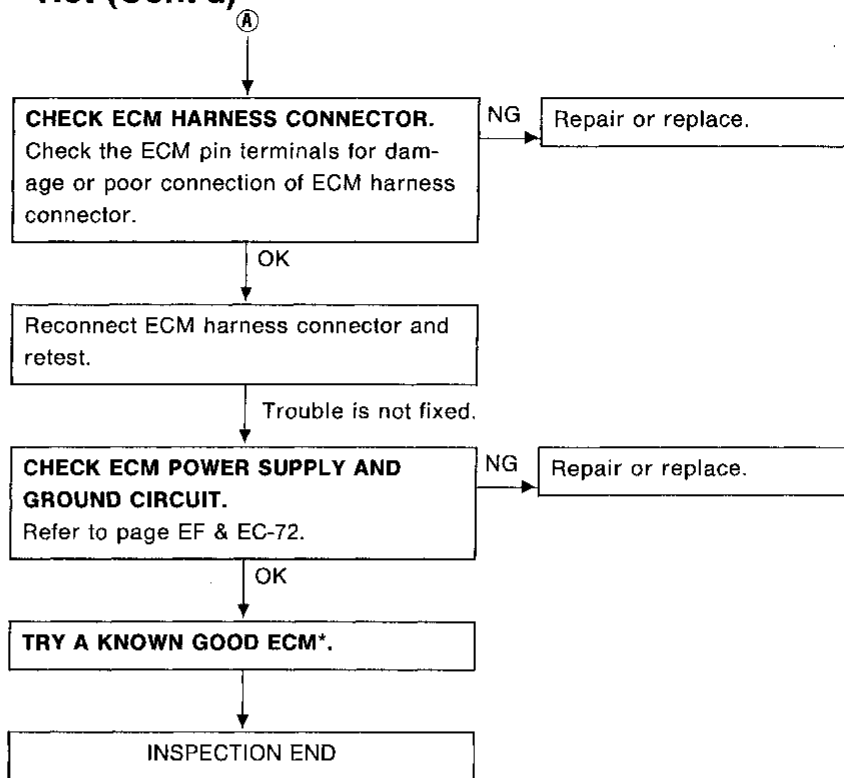

\*: ECM may be the cause of a problem, but this is rarely the case.

GI  
MA  
EM  
LC  
EF & EC  
FE  
CL  
MT  
AT  
FA  
RA  
BR  
ST  
BF  
HA  
EL  
IDX

**Diagnostic Procedure 37 — Symptom — Engine Stalls when Stepping on the Accelerator Momentarily**

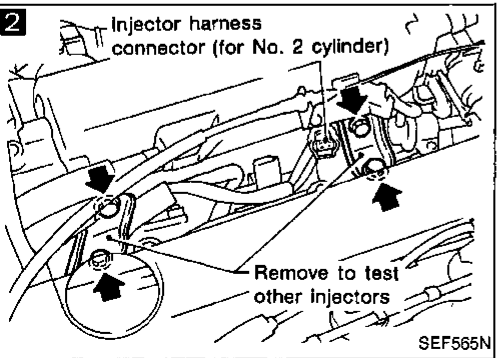
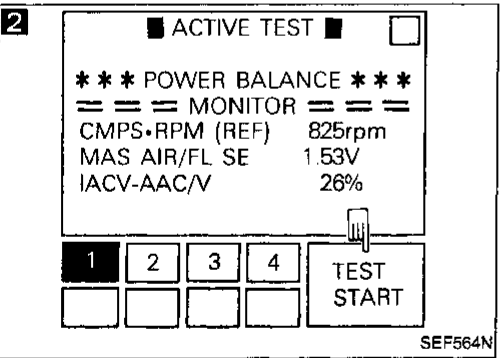
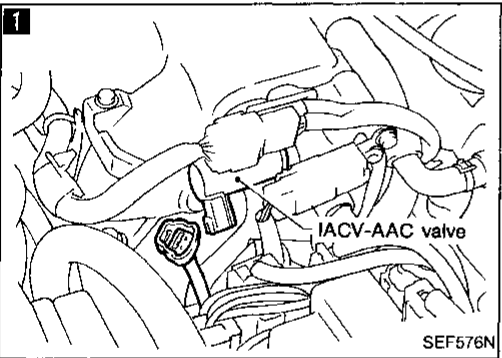
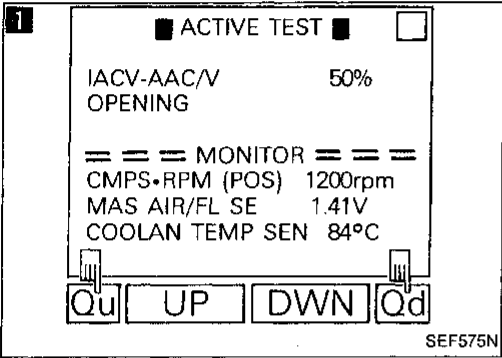
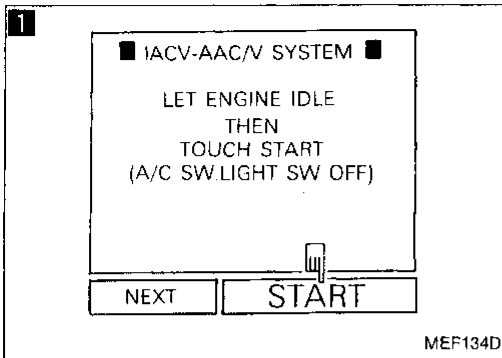

**1**

**CHECK IACV-AAC VALVE.**

1. Start engine and warm it up sufficiently.

2. Perform "IACV-AAC/V SYSTEM" in "FUNCTION TEST" mode.

OR

1. Select "IACV-AAC/V OPENING" in "ACTIVE TEST" mode.

2. When touching "Qu" and "Qd", does the engine speed change according to the percent of IACV-AAC valve opening?

OR

When disconnecting IACV-AAC valve harness connector, does the engine speed drop?

No → Check IACV-AAC valve and circuit. (See page EF & EC-121.)

**2**

**PERFORM POWER BALANCE TEST.**

1. Perform "POWER BALANCE" in "ACTIVE TEST" mode.

2. Is there any cylinder which does not produce a momentary engine speed drop?

OR

When disconnecting each injector harness connector one at a time, is there any cylinder which does not produce a momentary engine speed drop?

No → Go to 5.

Yes → (Go to A on next page.)

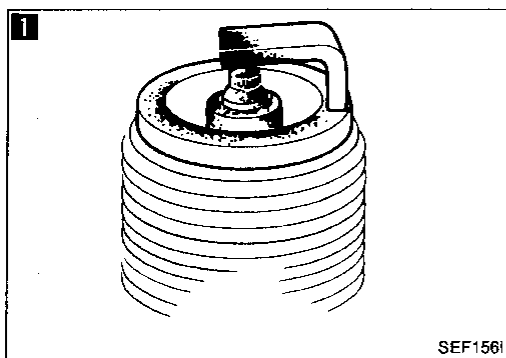

**Diagnostic Procedure 44 — Symptom — Backfire through the Intake**

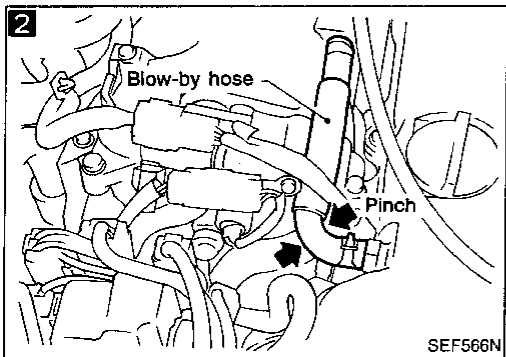
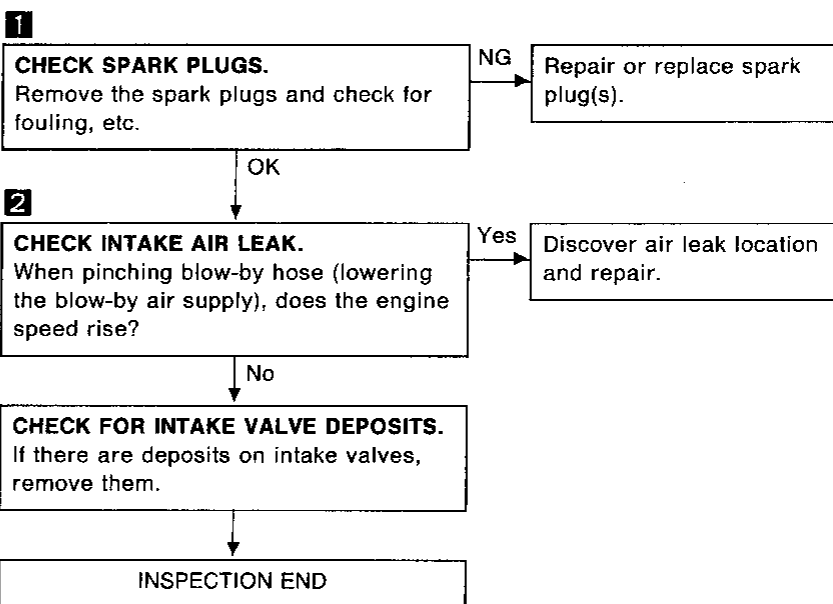

**Diagnostic Procedure 45 — Backfire through the Exhaust**

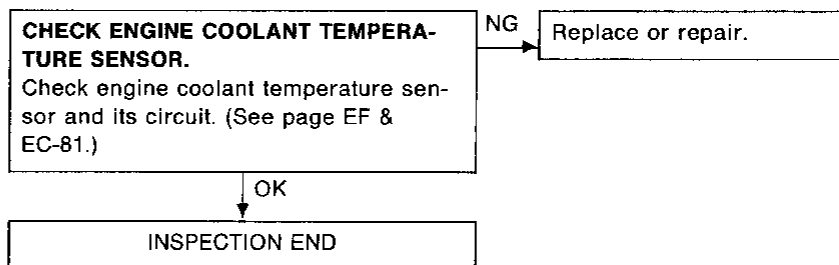

CLICK HERE TO **DOWNLOAD** THE COMPLETE MANUAL

- Thank you very much for reading the preview of the manual.
- You can download the complete manual from: [www.heydownloads.com](http://www.heydownloads.com) by clicking the link below



- Please note: If there is no response to CLICKING the link, please download this PDF first and then click on it.

CLICK HERE TO **DOWNLOAD** THE COMPLETE MANUAL

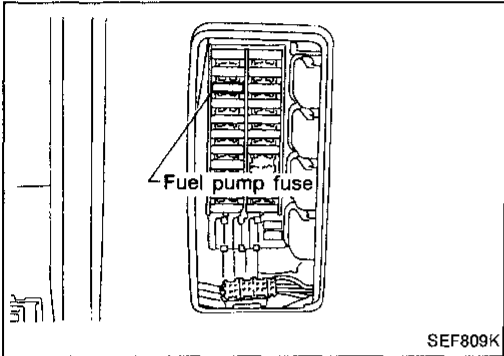
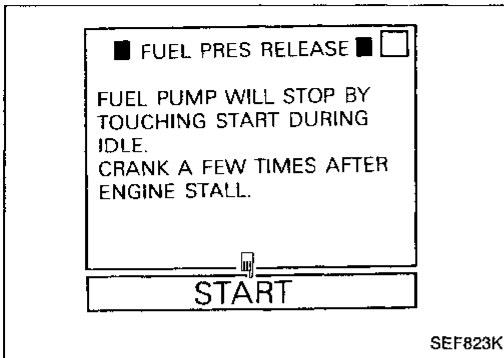

## Releasing Fuel Pressure

Before disconnecting fuel line, release fuel pressure from fuel line to eliminate danger.

1. Turn ignition switch "ON".
2. Perform "FUEL PRESSURE RELEASE" in "WORK SUPPORT" mode with CONSULT.
3. Start engine.
4. After engine stalls, crank it two or three times to release all fuel pressure.
5. Turn ignition switch off.

GI

MA

EM

1. Remove fuel pump fuse.
2. Start engine.
3. After engine stalls, crank it two or three times to release all fuel pressure.
4. Turn ignition switch off and reconnect fuel pump fuse.

LC

EF & EC

FE

CL

## Fuel Pressure Check

- a. When reconnecting fuel line, always use new clamps.
- b. Make sure that clamp screw does not contact adjacent parts.
- c. Use a torque driver to tighten clamps.
- d. Use Pressure Gauge to check fuel pressure.
- e. Do not perform fuel pressure check while fuel pressure regulator control system is operating; otherwise, fuel pressure gauge might indicate incorrect readings.

MT

AT

FA

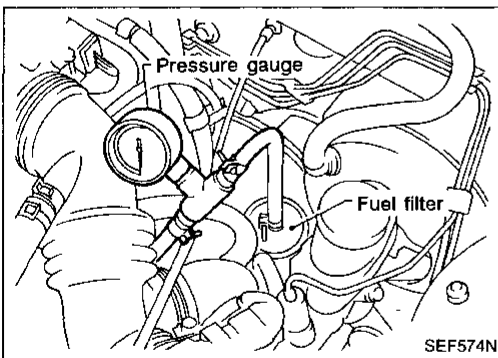

RA

BR

ST

BF

HA

EL

IDX

1. Release fuel pressure to zero.
2. Disconnect fuel hose between fuel filter and fuel tube (engine side).
3. Install pressure gauge between fuel filter and fuel tube.
4. Start engine and check for fuel leakage.
5. Read the indication of fuel pressure gauge.

**At idling: Approximately 245 kPa  
(2.5 kg/cm<sup>2</sup>, 36 psi)**

**A few seconds after ignition switch is turned OFF to ON: Approximately 294 kPa  
(3.0 kg/cm<sup>2</sup>, 43 psi)**

6. Stop engine and disconnect fuel pressure regulator vacuum hose from intake manifold.
7. Plug intake manifold with a rubber cap.
8. Connect variable vacuum source to fuel pressure regulator.
9. Start engine and read indication of fuel pressure gauge as vacuum is changed.

**Fuel pressure should decrease as vacuum increases. If results are unsatisfactory, replace fuel pressure regulator.**

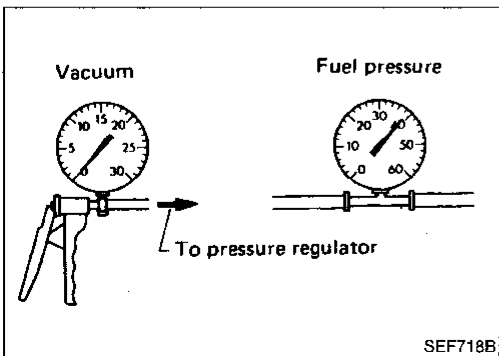

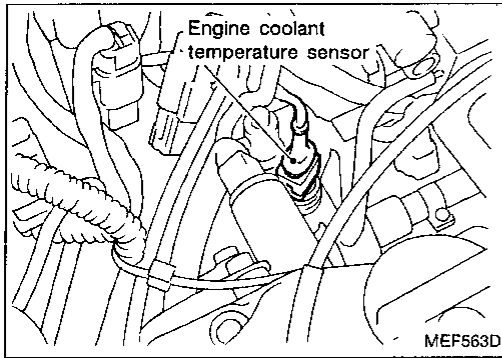

**Engine Coolant Temperature Sensor (ECTS)**

The engine coolant temperature sensor, located on the intake manifold, detects engine coolant temperature and transmits a signal to the ECM.

The temperature sensing unit employs a thermistor which is sensitive to the change in temperature. Electrical resistance of the thermistor decreases in response to the temperature rise.

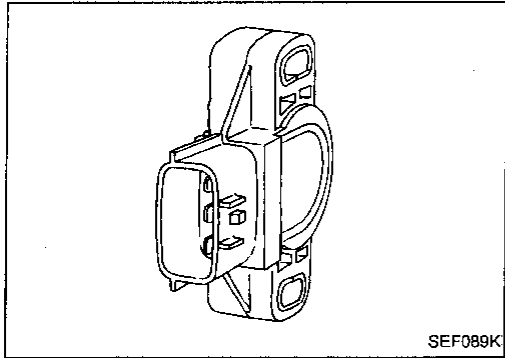

**Throttle Position Sensor (TPS) & Soft Closed Throttle Position (CTP) Switch**

The throttle position sensor responds to the accelerator pedal movement. This sensor is a kind of potentiometer which transforms the throttle position into output voltage, and emits the voltage signal to the ECM. In addition, the sensor detects the opening and closing speed of the throttle valve and feeds the voltage signal to the ECM.

Idle position of the throttle valve is determined by the ECM receiving the signal from the throttle position sensor. This system is called "soft closed throttle position switch". This one controls engine operation such as fuel cut.

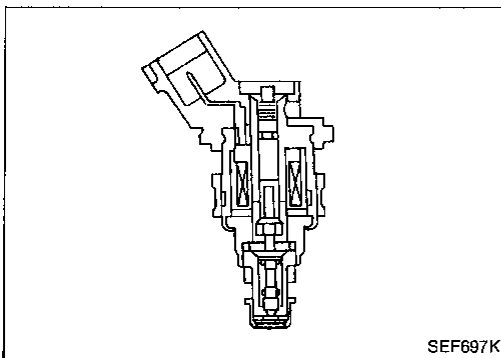
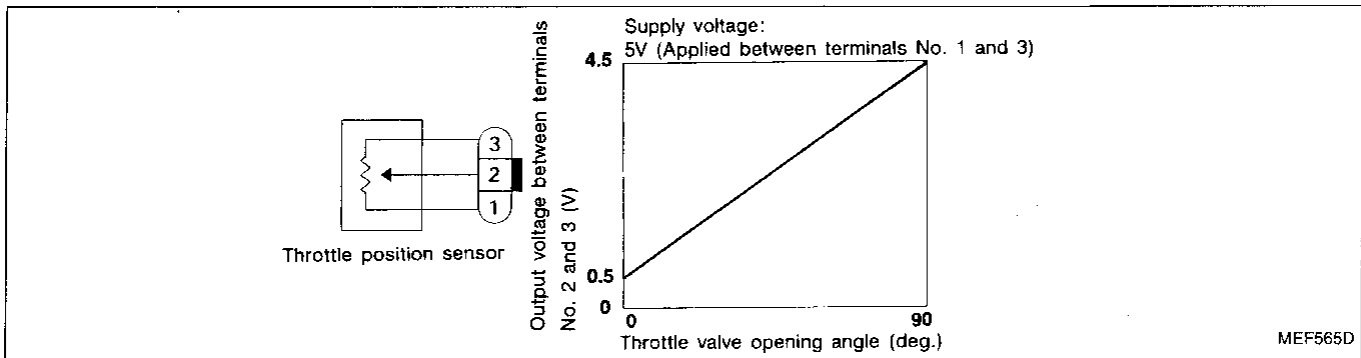

**Fuel Injector**

The fuel injector is a small, elaborate solenoid valve. As the ECM sends injection signals to the injector, the coil in the injector pulls the needle valve back and fuel is released into the intake manifold through the nozzle. The injected fuel is controlled by the ECM in terms of injection pulse duration.

Cooling Fan Control

INPUT/OUTPUT SIGNAL LINE

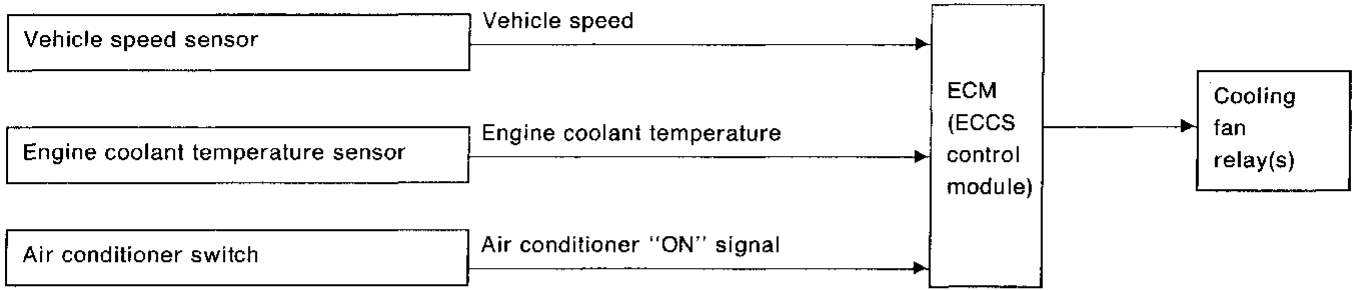

GI

MA

EM

LC

EF & EC

FE

CL

MT

AT

FA

RA

BR

ST

BF

HA

EL

IDX

EXCEPT A/T MODELS FOR U.S.A.

The ECM controls the cooling fan corresponding to the vehicle speed, engine coolant temperature, and air conditioner ON signal. The control system has 2-step control [ON/OFF].

Operation

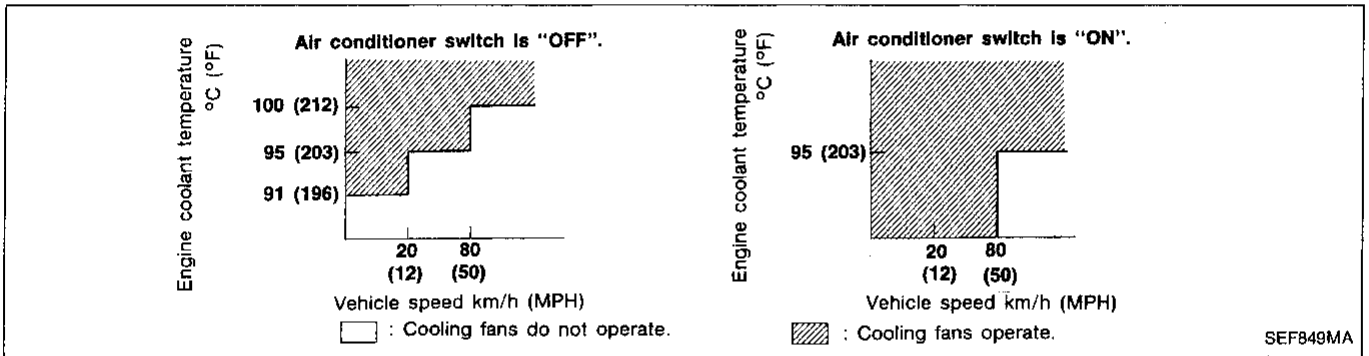

A/T MODELS FOR U.S.A.

The ECM controls the cooling fan corresponding to the vehicle speed, engine coolant temperature, and air conditioner ON-signal. The control system has 3-step control [HIGH/LOW/OFF].

Operation

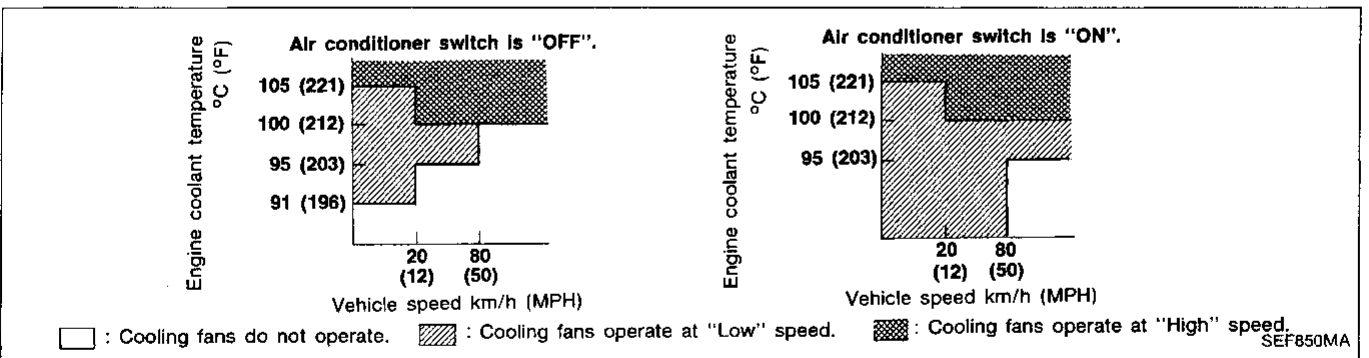

**Contents (Cont'd)**

<b>Diagnostic Procedure 19</b>		
IACV-AAC VALVE (Not self-diagnostic item) .....		EF & EC-310
<b>Diagnostic Procedure 20</b>		
IACV-AIR REGULATOR (Not self-diagnostic item) .....		EF & EC-313
<b>Diagnostic Procedure 21</b>		
COOLING FAN CONTROL (Not self-diagnostic item) .....		EF & EC-315
<b>Diagnostic Procedure 22</b>		
POWER STEERING OIL PRESSURE SWITCH (Not self-diagnostic item) .....		EF & EC-324
<b>Diagnostic Procedure 23</b>		
NEUTRAL POSITION/INHIBITOR SWITCH (Not self-diagnostic item) .....		EF & EC-327
<b>Diagnostic Procedure 24</b>		
VALVE TIMING CONTROL (Not self-diagnostic item) .....		EF & EC-332
<b>Diagnostic Procedure 25 — Symptom — High Idling after Warm-up</b> .....		EF & EC-335
<b>Diagnostic Procedure 26 — Symptom — Hunting</b> .....		EF & EC-336
<b>Diagnostic Procedure 27 — Symptom — Unstable Idle</b> .....		EF & EC-337
<b>Diagnostic Procedure 28 — Symptom — Hard to Start or Impossible to Start when the Engine is Cold</b> .....		EF & EC-340
<b>Diagnostic Procedure 29 — Symptom — Hard to Start or Impossible to Start when the Engine is Hot</b> .....		EF & EC-341
<b>Diagnostic Procedure 30 — Symptom — Hard to Start or Impossible to Start under Normal Conditions</b> .....		EF & EC-343
<b>Diagnostic Procedure 31 — Symptom — Hesitation when the Engine is Hot</b> .....		EF & EC-344
<b>Diagnostic Procedure 32 — Symptom — Hesitation when the Engine is Cold</b> .....		EF & EC-345
<b>Diagnostic Procedure 33 — Symptom — Hesitation under Normal Conditions</b> .....		EF & EC-346
<b>Diagnostic Procedure 34 — Symptom — Engine Stalls when Turning</b> .....		EF & EC-348
<b>Diagnostic Procedure 35 — Symptom — Engine Stalls when the Engine is Hot</b> .....		EF & EC-350
<b>Diagnostic Procedure 36 — Symptom — Engine Stalls when the Engine is Cold</b> .....		EF & EC-352
<b>Diagnostic Procedure 37 — Symptom — Engine Stalls when Stepping on the Accelerator Momentarily</b> .....		EF & EC-354
<b>Diagnostic Procedure 38 — Symptom — Engine Stalls after Decelerating</b> .....		EF & EC-356
<b>Diagnostic Procedure 39 — Symptom — Engine Stalls when Accelerating or when Driving at Constant Speed</b> .....		EF & EC-360
<b>Diagnostic Procedure 40 — Symptom — Engine Stalls when the Electrical Load is Heavy</b> .....		EF & EC-362
<b>Diagnostic Procedure 41 — Symptom — Lack of Power and Stumble</b> .....		EF & EC-364
<b>Diagnostic Procedure 42 — Symptom — Knock</b> .....		EF & EC-364
<b>Diagnostic Procedure 43 — Symptom — Surge</b> .....		EF & EC-366
<b>Diagnostic Procedure 44 — Symptom — Backfire through the Intake</b> .....		EF & EC-367
<b>Diagnostic Procedure 45 — Symptom — Backfire through the Exhaust</b> .....		EF & EC-367
<b>Electrical Components Inspection</b> .....		EF & EC-368

Consult (Cont'd)

ECCS COMPONENT PARTS APPLICATION

ECCS COMPONENT PARTS		DIAGNOSTIC TEST MODE				
		WORK SUPPORT	SELF-DIAGNOSTIC RESULTS	DATA MONITOR	ACTIVE TEST	FUNCTION TEST
INPUT	Camshaft position sensor		X	X		
	Mass air flow sensor		X	X		
	Engine coolant temperature sensor		X	X	X	
	Oxygen sensors*		X	X		X
	Vehicle speed sensors		X	X		X
	Throttle position sensor	X	X	X		X
	EGR temperature sensor		X	X		
	Ignition switch (start signal)			X		X
	Air conditioner switch			X		
	Neutral position switch			X		X
	Power steering oil pump switch			X		X
	Load switch			X		
	Battery			X		
OUT-PUT	Injectors		X	X	X	
	Power transistor (ignition timing)	X	X (Ignition signal)	X	X	X
	IACV-AAC valve	X		X	X	X
	Valve timing control solenoid valve			X	X	X
	EGR & canister control solenoid valve		X	X	X	X
	Air conditioner relay			X		
	Fuel pump relay	X		X	X	X
	Cooling fan			X	X	X

\*: Heated oxygen sensor (A/T models except for California)  
 Oxygen sensor (A/T models for California and M/T models)  
 X: Applicable

Basic Inspection (Cont'd)

**7**

☆MONITOR ☆NO FAIL

START SIGNAL OFF  
 CLOSED TH/POS ON  
 AIR COND SIG OFF  
 NEUT POSI SW ON

RECORD

MEF574D

**7**



A/C



ST

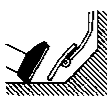



SEF150I

**8**

■ SELF-DIAG RESULTS ■

FAILURE DETECTED TIME  
 COOLANT TEMP SEN 0

ERASE PRINT

MEF578D

**8**

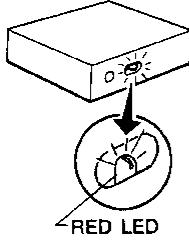

RED LED

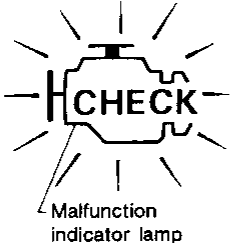

Malfunction indicator lamp

MEF377DA

**8**

↓

**7**

**CHECK SWITCH INPUT SIGNAL.**

 Select the following switches in "DATA MONITOR" mode,

- a) Start signal,
- b) Idle position,
- c) Air conditioner signal,
- d) Neutral position (Park positioning) switch,

and check the switches' ON-OFF operation.

OR

 Remove ECM from behind audio system panel and check the above switches' ON-OFF operation using voltmeter at each ECM terminal.

Switch	Condition	Voltage (V)
Start signal	IGN ON	IGN → START
		0 → Battery Voltage
Idle position	—	—
A/C signal	A/C OFF	A/C → ON
		Battery voltage → 0 - 0.3 (Engine running)
Neutral position (parking) Switch	Shift lever is Neutral position → Except neutral position	0 → Battery voltage

NG → Repair or replace the malfunctioning switch or its circuit.

OK

**8**

**READ SELF-DIAGNOSTIC RESULTS.**

 1. Perform "SELF-DIAG RESULTS" mode.

2. Read out self-diagnostic results.

3. Is a failure detected?

OR

 1. Set "Self-diagnostic results mode" in Diagnostic Test Mode II. (Refer to page EF & EC-237.)

2. Count the number of RED LED flashes and read out the diagnostic trouble codes.

3. Are the diagnostic trouble codes shown?

Yes → Go to the relevant inspection procedure.

No

INSPECTION END

CAMSHAFT POSITION SENSOR (Diagnostic trouble code No. 11)

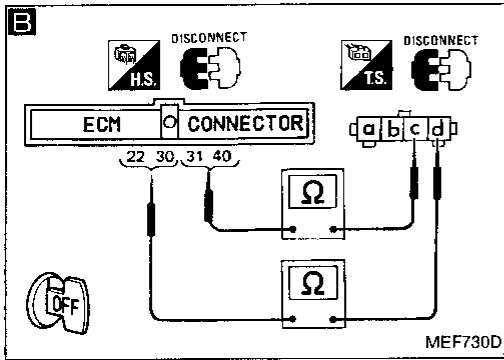
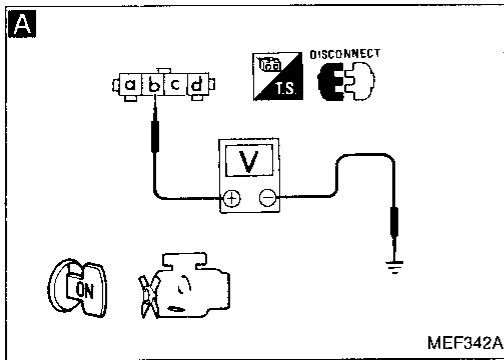

```

    graph TD
      Start[INSPECTION START] --> Step1[PERFORM DIAGNOSTIC TEST MODE II  
(SELF-DIAGNOSTIC RESULTS).  
See page EF & EC-255.]
      Step1 -- OK --> Step1_Exit[Go to "CAMSHAFT POSITION SENSOR  
(Not self-diagnostic item)".]
      Step1 -- NG --> Step2[CHECK POWER SUPPLY.  
1) Turn ignition switch "OFF".  
2) Disconnect camshaft position sensor  
harness connector.  
3) Turn ignition switch "ON".  
4) Check voltage between terminal (b)  
and ground with CONSULT or tester.  
Voltage: Battery voltage]
      Step2 -- NG --> Step2_Exit[Check the following.  
• Harness continuity between camshaft position  
sensor and ECM  
• Harness continuity between camshaft position  
sensor and ECCS relay  
If NG, repair harness or connectors.]
      Step2 -- OK --> Step3[Loosen and retighten ground screws.]
      Step3 --> Step4[CHECK INPUT SIGNAL CIRCUIT.  
1) Turn ignition switch "OFF".  
2) Disconnect ECM harness connector.  
3) Check harness continuity between  
terminal (a) and ECM terminals (22),  
(30) (180° signal), terminal (c) and  
ECM terminals (31), (40) (1° signal).  
Continuity should exist.]
      Step4 -- NG --> Step4_Exit[Repair harness or connectors.]
      Step4 -- OK --> Step5[CHECK COMPONENT  
(Camshaft position sensor).  
Refer to "Electrical Components  
Inspection".  
(See page EF & EC-372.)]
      Step5 -- NG --> Step5_Exit[Replace camshaft position  
sensor.]
      Step5 -- OK --> Step6[Disconnect and reconnect harness connectors  
in the circuit, and retest.]
      Step6 --> Step7[Trouble is not fixed.]
      Step7 --> Step8[Check ECM pin terminals for damage or  
the connection of ECM harness connector.  
Reconnect ECM harness connector  
and retest.]
  
```

GI  
MA  
EM  
LC  
EF & EC  
FE  
CL  
MT  
AT  
FA  
RA  
BR  
ST  
BF  
HA  
EL  
IDX

## Diagnostic Procedure 7

ECM (ECCS CONTROL MODULE) (Diagnostic trouble code No. 31)  
HCHECK (Malfunction indicator lamp item)

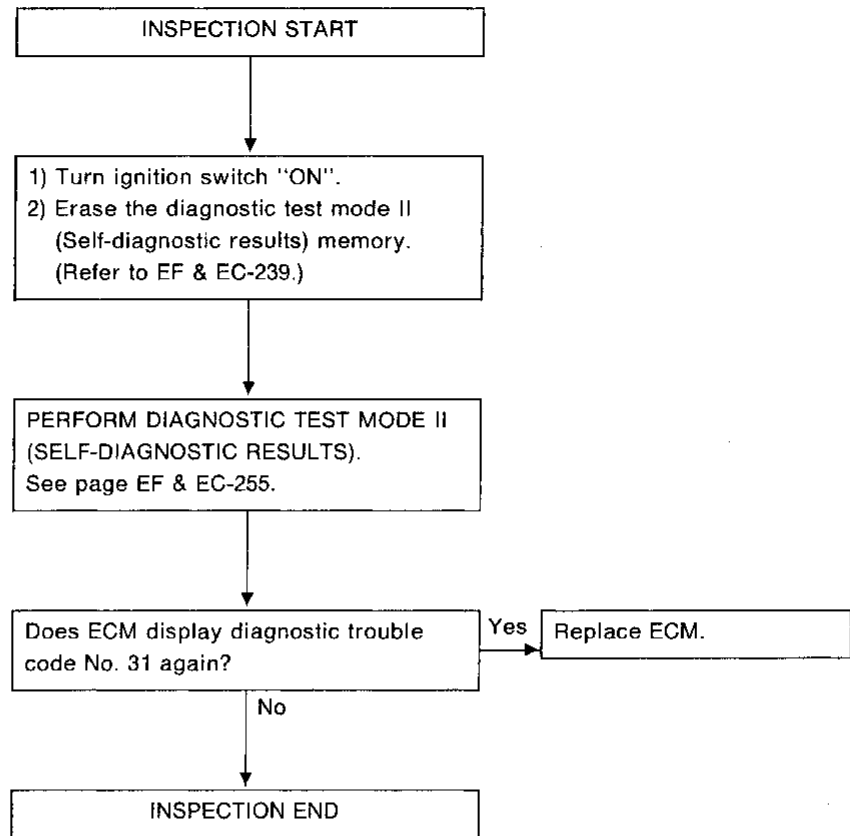

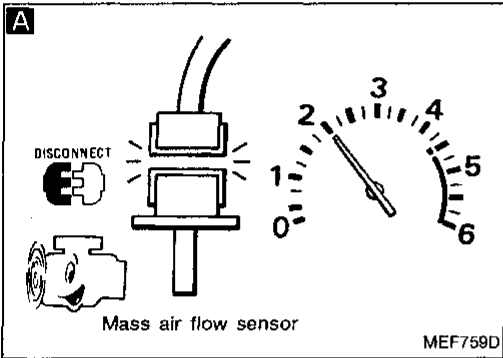
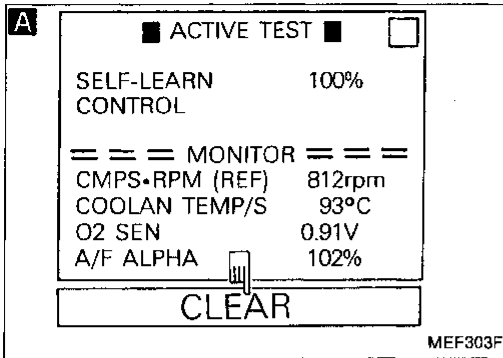

**Diagnostic Procedure 12**

**INJECTOR LEAK (Diagnostic trouble code No. 45)**  
 (Malfunction indicator lamp item)

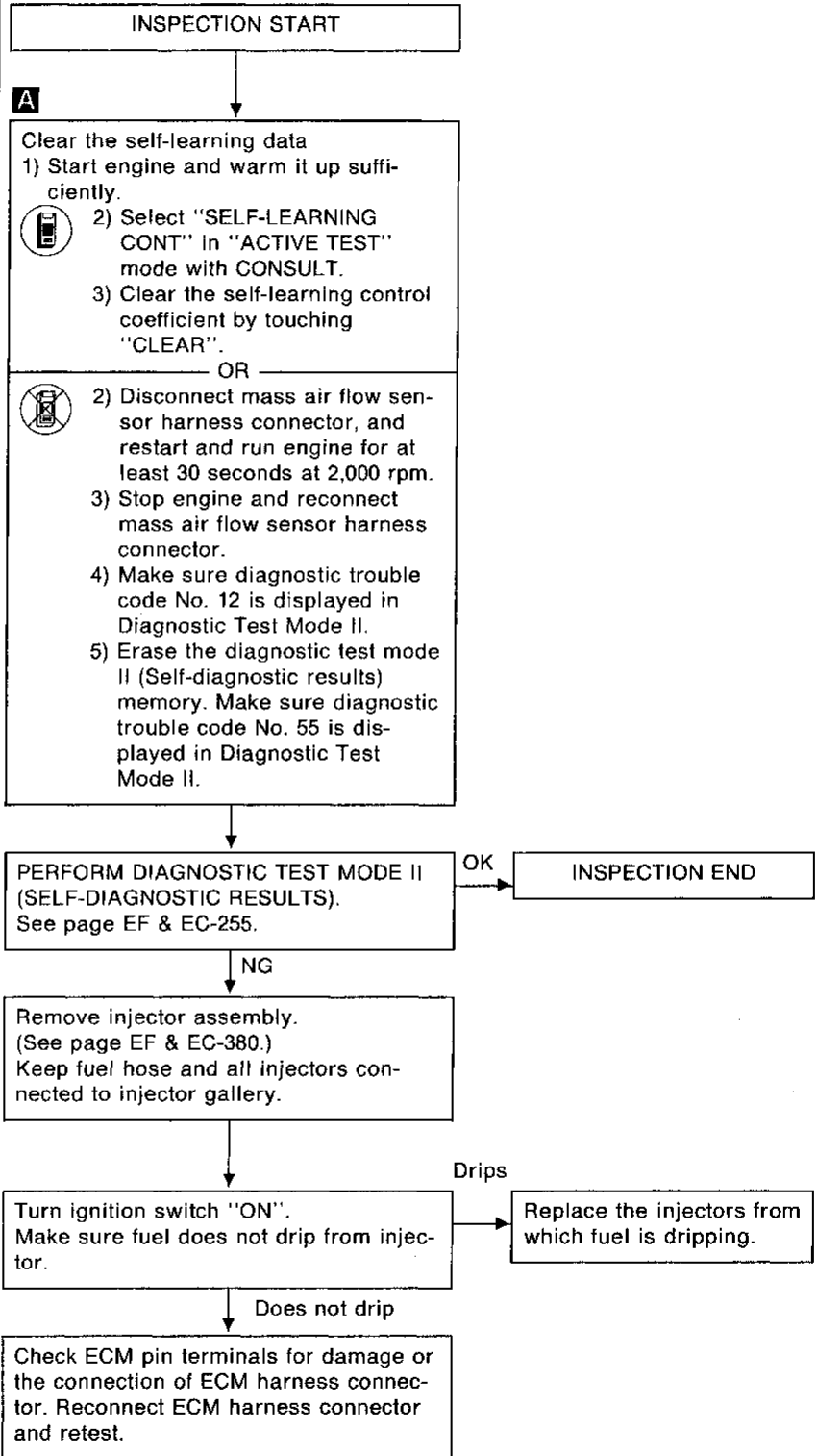

GI  
 MA  
 EM  
 LC  
 EF & EC  
 FE  
 CL  
 MT  
 AT  
 FA  
 RA  
 BR  
 ST  
 BF  
 HA  
 EL  
 IDX

## START SIGNAL (Not self-diagnostic item)

**A**

■ START SIGNAL CKT ■

1. CLOSE THROTTLE, SHIFT TO P OR N RANGE.
2. TOUCH START AND START ENGINE IMMEDIATELY.

NEXT    START

MEF481B

**A**

☆ MONITOR    ☆ NO FAIL

START SIGNAL	ON
CLOSED TH/POS	ON
AIR COND SIG	OFF
NEUT POSI SW	ON

RECORD

MEF774D

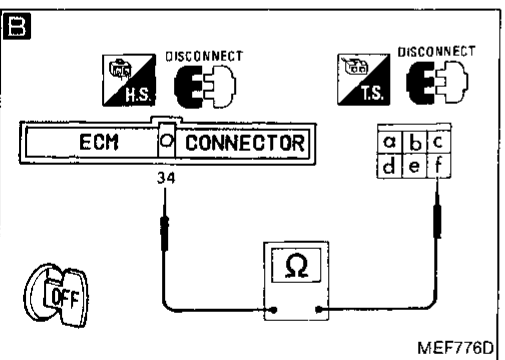
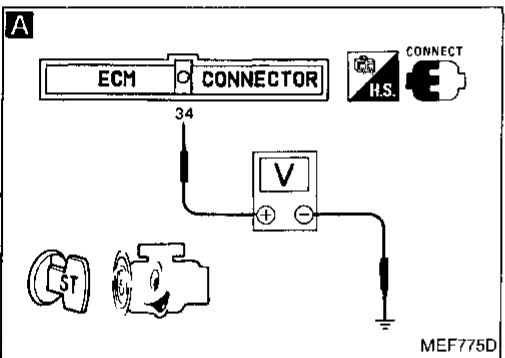

```

    graph TD
      Start[INSPECTION START] --> A1[CHECK OVERALL FUNCTION.]
      A1 -- OK --> End1[INSPECTION END]
      A1 --> A2[CHECK INPUT SIGNAL CIRCUIT.]
      A2 -- NG --> A3[Check the following.]
      A3 --> A4[Disconnect and reconnect harness connectors in the circuit, and retest.]
      A4 --> A5[Trouble is not fixed.]
      A5 --> A6[Check ECM pin terminals for damage or the connection of ECM harness connector. Reconnect ECM harness connector and retest.]
      A6 --> End2[INSPECTION END]
  
```

INSPECTION START

**A**

CHECK OVERALL FUNCTION.

- 1) Turn ignition switch "ON".
- 2) Perform "START SIGNAL CKT" in "FUNCTION TEST" mode with CONSULT.

OR

- 1) Turn ignition switch "ON".
- 2) Check "START SIGNAL" in "DATA MONITOR" mode with CONSULT.

IGN "ON"	OFF
IGN "START"	ON

OR

- 1) Turn ignition switch to "START".
- 2) Check voltage between ECM terminal 34 and ground.

**Voltage:**

Ignition switch "START"

Battery voltage

Except above

Approximately 0V

**B**

CHECK INPUT SIGNAL CIRCUIT.

- 1) Turn ignition switch "OFF"
- 2) Disconnect ECM harness connector and ignition switch harness connector.
- 3) Check harness continuity between ECM terminal 34 and terminal 1.

**Continuity should exist.**

Disconnect and reconnect harness connectors in the circuit, and retest.

Trouble is not fixed.

Check ECM pin terminals for damage or the connection of ECM harness connector. Reconnect ECM harness connector and retest.

INSPECTION END

Check the following.

- Harness connectors (F17), (M36)
- 10A fuse
- Harness connectors (M9), (E41)
- Harness continuity between ECM and ignition switch

If NG, repair harness or connectors.

COOLING FAN CONTROL (Not self-diagnostic item)

**E**

■ COOLING FAN CIRCUIT ■

DOES  
COOLING FAN  
ROTATE AND STOP  
EVERY 3 SECONDS ?

NEXT NO YES

MEF311F

**E**

■ ACTIVE TEST ■

COOLING FAN OFF

=== MONITOR ===

COOLAN TEMP/S 88°C

HI LOW OFF

MEF313F

**E**

With air conditioner

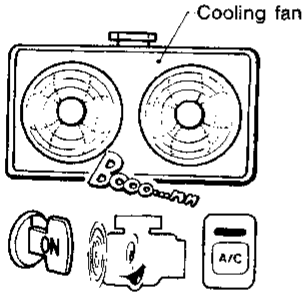

Without air conditioner

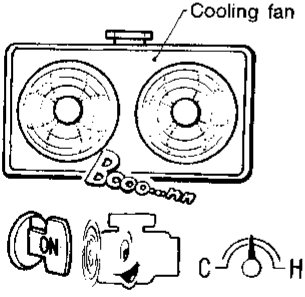

SEF9971A

A/T models for U.S.A.

INSPECTION START

**E**

CHECK COOLING FAN LOW SPEED OPERATION.

1) Disconnect cooling fan relay-2.

2) Turn ignition switch "ON".

3) Perform "COOLING FAN CIRCUIT" in "FUNCTION TEST" mode with CONSULT.

OR

2) Turn ignition switch "ON".

3) Perform "COOLING FAN" in "ACTIVE TEST" mode with CONSULT.

OR

 With air conditioner

- 1) Start engine.
- 2) Set temperature lever at full cold position.
- 3) Turn air conditioner switch "ON".
- 4) Turn blower fan switch "ON".
- 5) Run engine at idle for a few minutes with air conditioner operating.
- 6) Make sure that cooling fan operates at low speed.

Without air conditioner

- 1) Start engine.
- 2) Keep engine speed at about 2,000 rpm until engine is warmed up sufficiently.
- 3) Make sure that cooling fan begins to operate at low speed during warm-up.

NG Check cooling fan low speed control circuit. (Go to PROCEDURE A.)

OK

A

GI

MA

EM

LC

EF & EC

FE

CL

MT

AT

FA

RA

BR

ST

BF

HA

EL

DX

Diagnostic Procedure 24

VALVE TIMING CONTROL (Not self-diagnostic item)

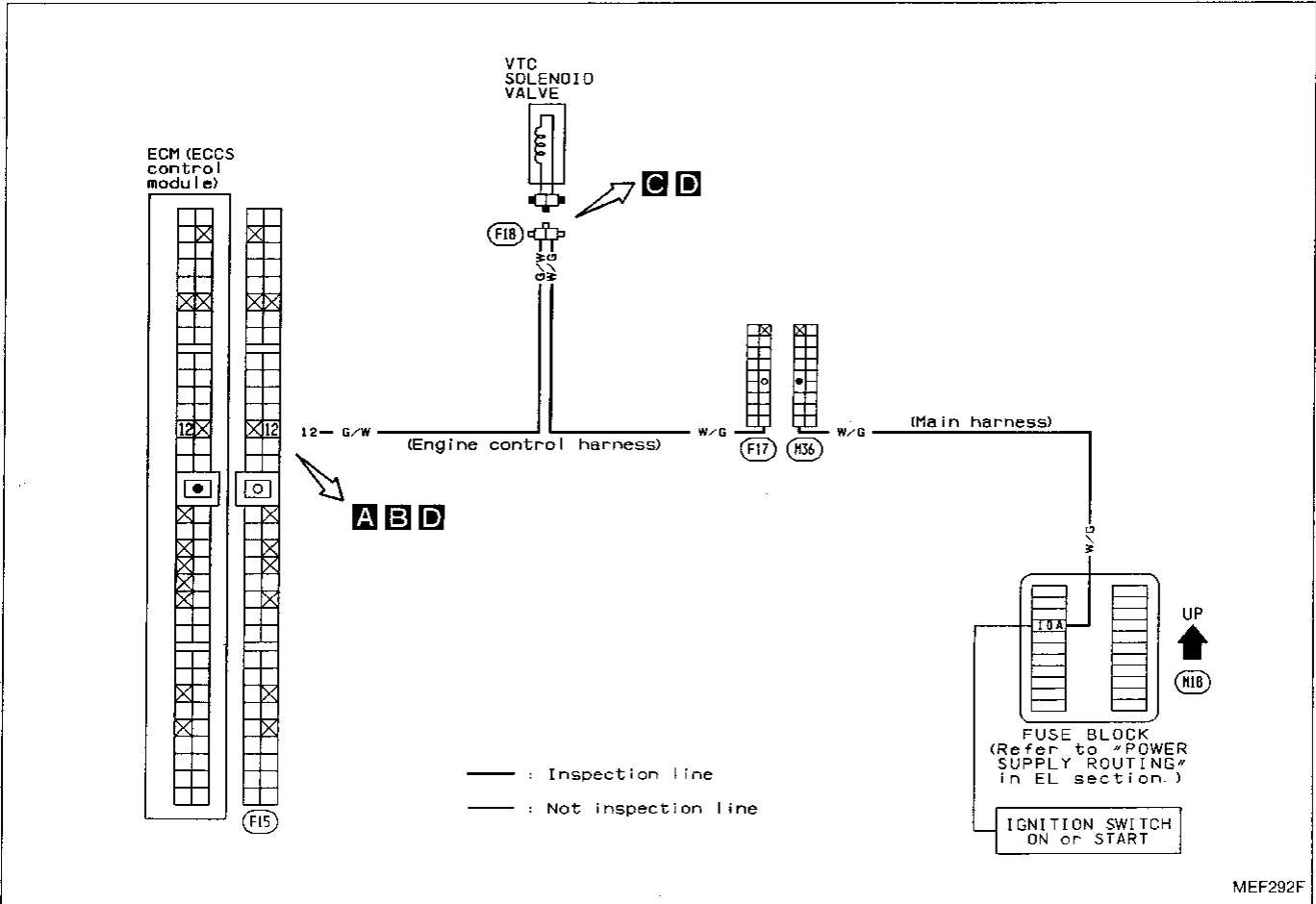

Harness layout

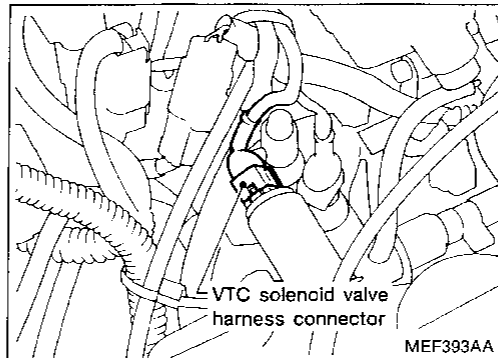
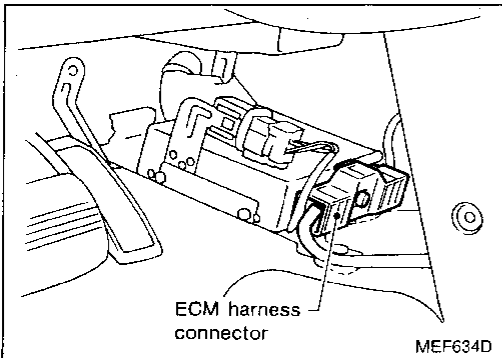

**Diagnostic Procedure 31 — Symptom — Hesitation when the Engine is Hot (Cont'd)**

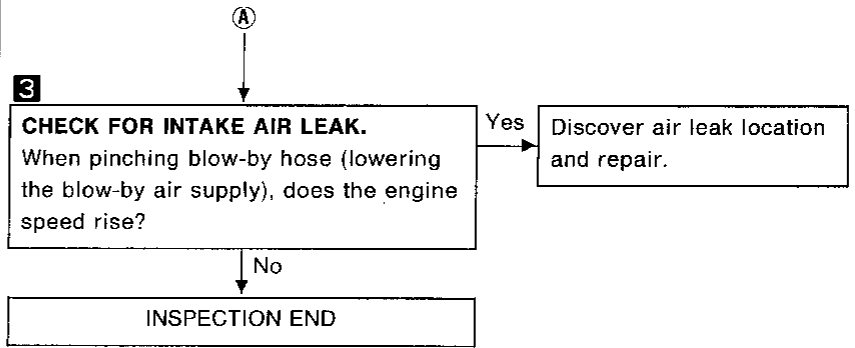
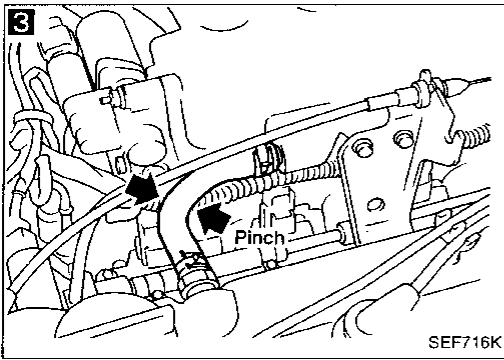

GI

MA

EM

LC

EF & EC

FE

CL

WT

AT

FA

RA

BR

ST

BF

HA

EL

IDX

**Diagnostic Procedure 32 — Symptom — Hesitation when the Engine is Cold**

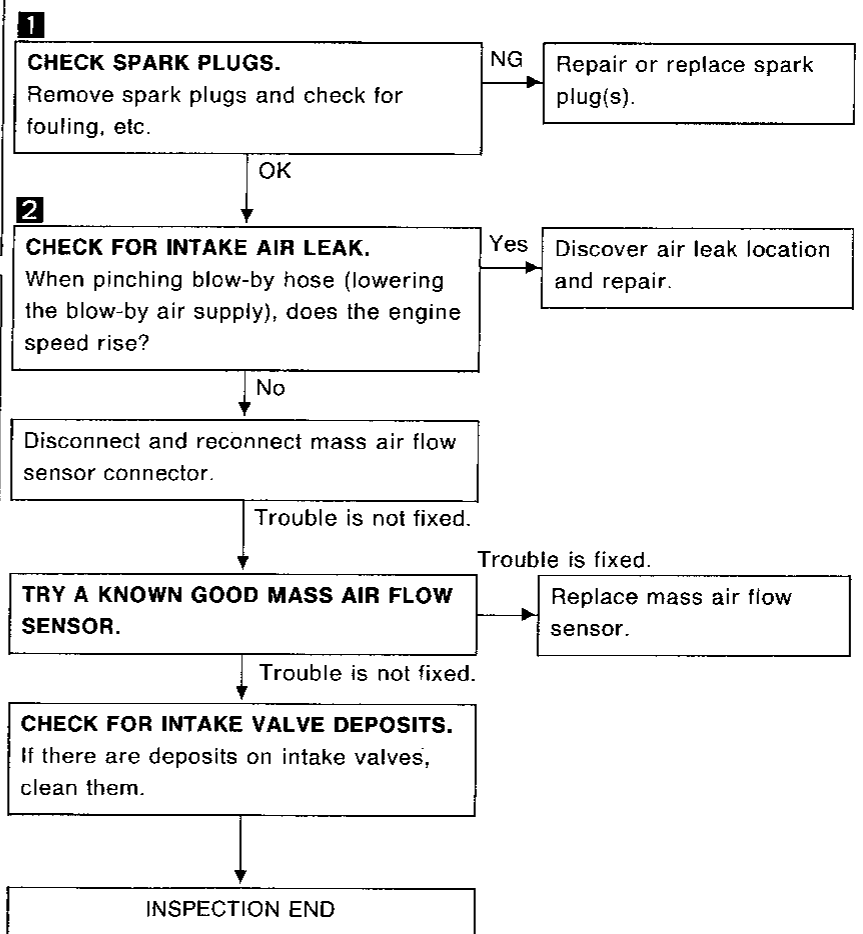
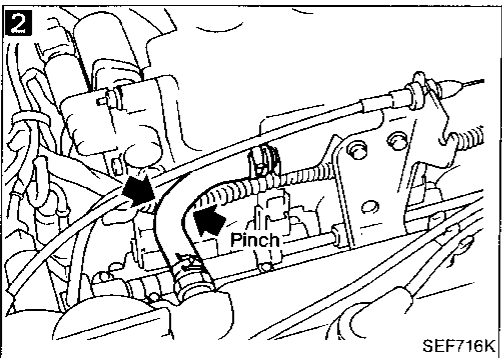
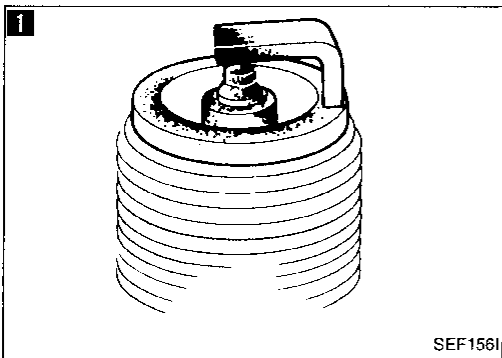

Diagnostic Procedure 38 — Symptom — Engine Stalls after Decelerating (Cont'd)

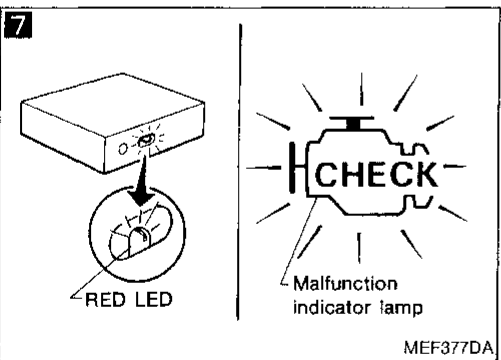
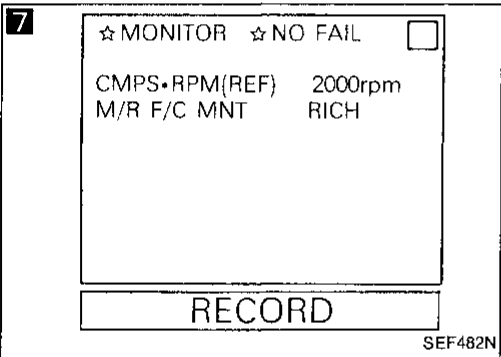
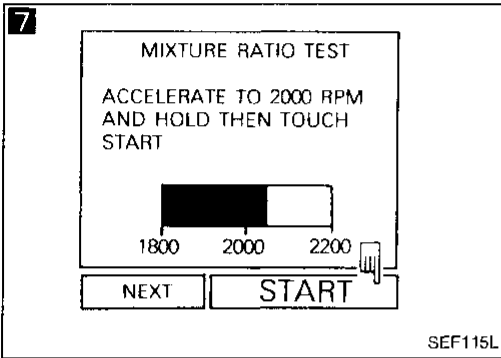
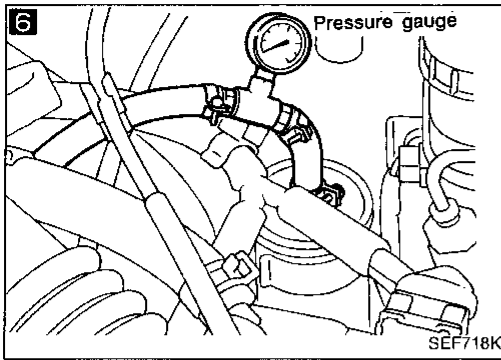

ⓑ

**6**

**CHECK FUEL PRESSURE.**

1. Release fuel pressure to zero. (Refer to page EF & EC-379.)
2. Install fuel pressure gauge and check fuel pressure.

**At idle:**

**Approx. 245 kPa**  
(2.5 kg/cm<sup>2</sup>, 36 psi)

**The moment throttle valve is fully open:**

**Approx. 294 kPa**  
(3.0 kg/cm<sup>2</sup>, 43 psi)

NG → Check fuel pressure regulator diaphragm.

OK

**7**

**CHECK OXYGEN SENSOR\*.**

1. Start engine and warm it up sufficiently.
2. Perform "MIXTURE RATIO TEST" in "FUNCTION TEST" mode.

OR

2. See "M/R F/C MNT" in "DATA MONITOR" mode.
3. Maintaining engine at 2,000 rpm under no-load (with engine warmed up sufficiently.), check to make sure that the monitor fluctuates between "LEAN" and "RICH" more than 5 times during 10 seconds.

**RICH → LEAN → RICH →**  
1 time                      2 times

**LEAN → RICH.....**

OR

2. Set "Oxygen sensor monitor\*" in Diagnostic Test Mode II. (See page EF & EC-239.)
3. Maintaining engine at 2,000 rpm under no-load, check that the RED LED on the ECM or the malfunction indicator lamp on the instrument panel goes ON and OFF more than 5 times during 10 seconds.

NG → Replace oxygen sensor\*.

OK

(Go to Ⓒ on next page.)

\*: Heated oxygen sensor (A/T models except for California)  
Oxygen sensor (A/T models for California and M/T models)

# TROUBLE DIAGNOSES

GA

## Electrical Components Inspection (Cont'd)

\*Data are reference values.

TERMINAL NO.	ITEM	CONDITION	*DATA	
43	Power steering oil pressure switch	Engine is running. └ Steering wheel is being turned.	0V	GI
		Engine is running. └ Steering wheel is not being turned.	Approximately 5V	MA
45	Fan switch	Engine is running. └ Fan switch is "ON".	Approximately 0V	EM
		Engine is running. └ Fan switch is "OFF".	BATTERY VOLTAGE (11 - 14V)	LC
46	Power supply (Back-up)	Ignition switch "OFF"	BATTERY VOLTAGE (11 - 14V)	EF & EC
101	Injector No. 1	Engine is running.	BATTERY VOLTAGE (11 - 14V)	FE
103	Injector No. 3			
110	Injector No. 2			
112	Injector No. 4			CL
104	Fuel pump relay	Ignition switch "ON" └ For 5 seconds after turning ignition switch "ON" Engine is running.	Approximately 0V	MT
		Ignition switch "ON" └ 5 seconds after turning ignition switch "ON"	BATTERY VOLTAGE (11 - 14V)	AT FA
105	EGR & canister control solenoid valve	Engine is running. (Warm-up condition) └ Idle speed	Approximately 0V	RA
		Engine is running. (Warm-up condition) └ Engine speed is about 2,000 rpm.	BATTERY VOLTAGE (11 - 14V)	BR
111	Heated oxygen sensor heater	Ignition switch "ON"	BATTERY VOLTAGE (11 - 14V)	ST
		Engine is running. └ Engine speed is below 6,000 rpm	Approximately 0V	BF
113	IACV-AAC valve	Engine is running. └ Idle speed	11 - 14V	HA
		Engine is running. └ Steering wheel is being turned. └ Air conditioner is operating. └ Rear defogger is "ON". └ Headlamp is "ON".	5 - 11V	EL LDX

**Inspection (Cont'd)****VENTILATION HOSE**

1. Check hoses and hose connections for leaks.
2. Disconnect all hoses and clean with compressed air. If any hose cannot be freed of obstructions, replace.

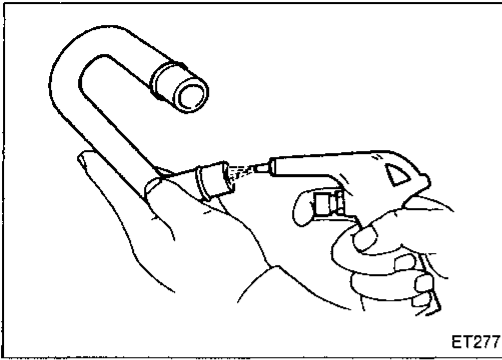

# BATTERY

## CAUTION:

- If it becomes necessary to start the engine with a booster battery and jumper cables, use a 12-volt booster battery.
- After connecting battery cables, ensure that they are tightly clamped to battery terminals for good contact.
- Never add distilled water through the hole used to check specific gravity.

GI

MA

EW

LC

EF &  
EC

FE

CL

MT

AT

FA

RA

BR

ST

BF

HA

EL

IDX

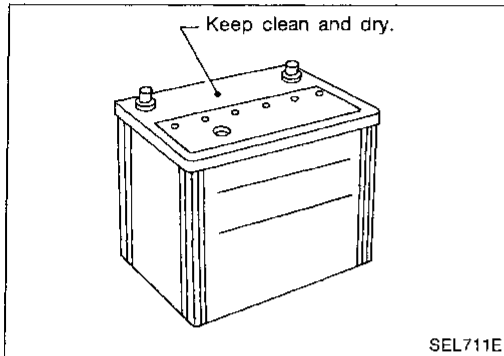

## How to Handle Battery

### METHODS OF PREVENTING OVER-DISCHARGE

The following precautions must be taken to prevent over-discharging a battery.

- The battery surface (particularly its top) should always be kept clean and dry.
  - The terminal connections should be clean and tight.
  - At every routine maintenance, check the electrolyte level.
- 
- When the vehicle is not going to be used over a long period of time, disconnect the negative battery terminal. (If the vehicle has an extended storage switch, turn it off.)

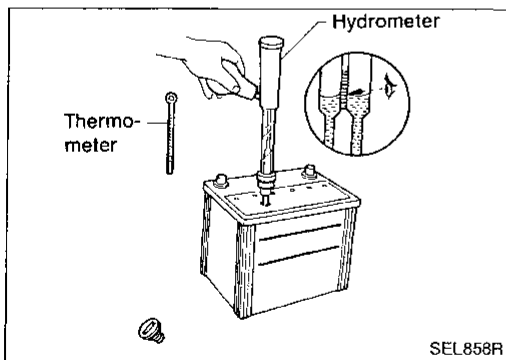
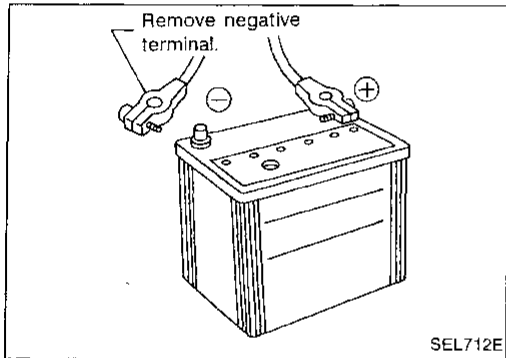

- Check the charge condition of the battery. Periodically check the specific gravity of the electrolyte. Keep a close check on charge condition to prevent over-discharge.

# CHARGING SYSTEM/COMBINATION SWITCH

## Service Data and Specifications (SDS)

### ALTERNATOR

Type	LR180-725C	A2T13894	LR170-738C	A5T04392A	
	HITACHI	MITSUBISHI	HITACHI	MITSUBISHI	
Applied model	SR20DE		GA16DE		
Nominal rating	V-A	12-80		12-70	
Ground polarity	Negative				
Minimum revolution under no-load (When 13.5 volts is applied)	rpm	Less than 1,000	1,300	Less than 1,000	Less than 1,300
Hot output current	A/rpm	More than 23/1,300 More than 63/2,500 More than 77/5,000	More than 22/1,300 More than 65/2,500	More than 22/1,300 More than 50/2,500 More than 67/5,000	More than 21/1,300 More than 50/2,500
Regulated output voltage	V	14.1 - 14.7			
Minimum length of brush	mm (in)	6.0 (0.236)	8.0 (0.315)	6.0 (0.236)	8.0 (0.315)
Brush spring pressure	N (g, oz)	1.000 - 3.432 (102 - 350, 3.60 - 12.34)	3.138 - 4.315 (320 - 440, 11.29 - 15.52)	1.000 - 3.432 (102 - 350, 3.60 - 12.34)	3.138 - 4.315 (320 - 440, 11.29 - 15.52)
Slip ring minimum outer diameter	mm (in)	More than 26.0 (1.024)	More than 22.1 (0.870)	More than 26.0 (1.024)	More than 22.1 (0.870)
Rotor (Field coil) resistance	$\Omega$	2.6 - 2.7	2.3 - 2.7	2.5 - 2.6	2.5 - 3.0

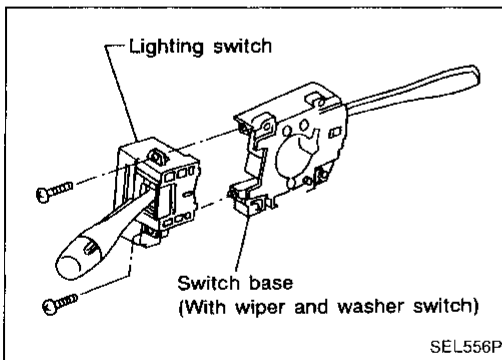

### Replacement

**For methods for removing/installing air bag module and spiral cable, refer to BF section.**

- Lighting switch can be replaced without removing combination switch base.

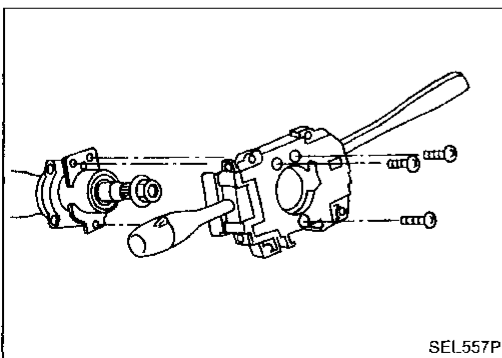

- To remove combination switch base, remove base attaching screw.

# INTERIOR LAMP

## Interior and Trunk Room Lamps/Wiring Diagram

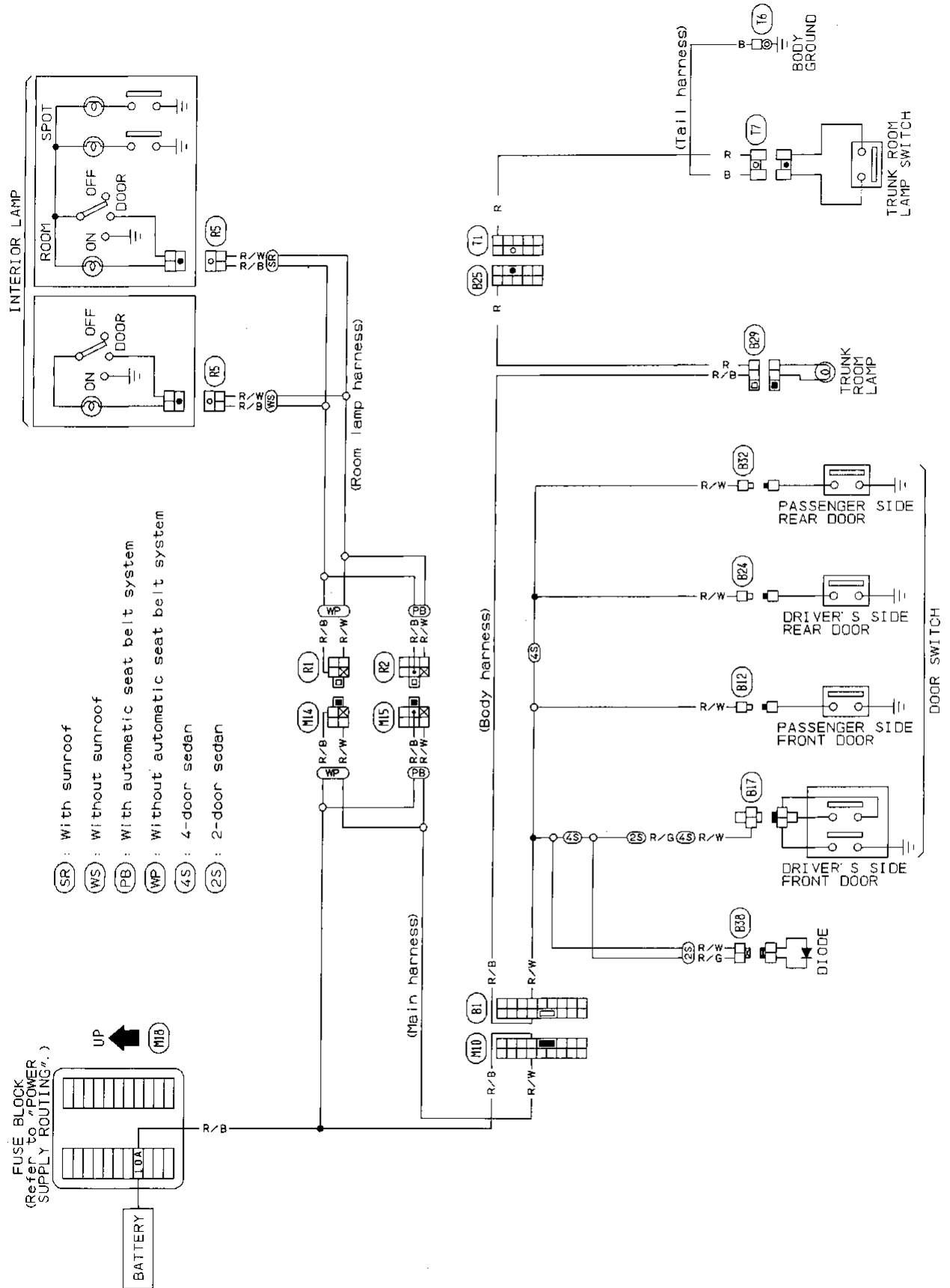

- GI
- WA
- EM
- LC
- FF & EC
- FE
- CL
- MT
- AT
- FA
- RA
- BR
- ST
- BF
- HA
- EL**
- IDX



# HORN, CIGARETTE LIGHTER AND CLOCK

## Wiring Diagram

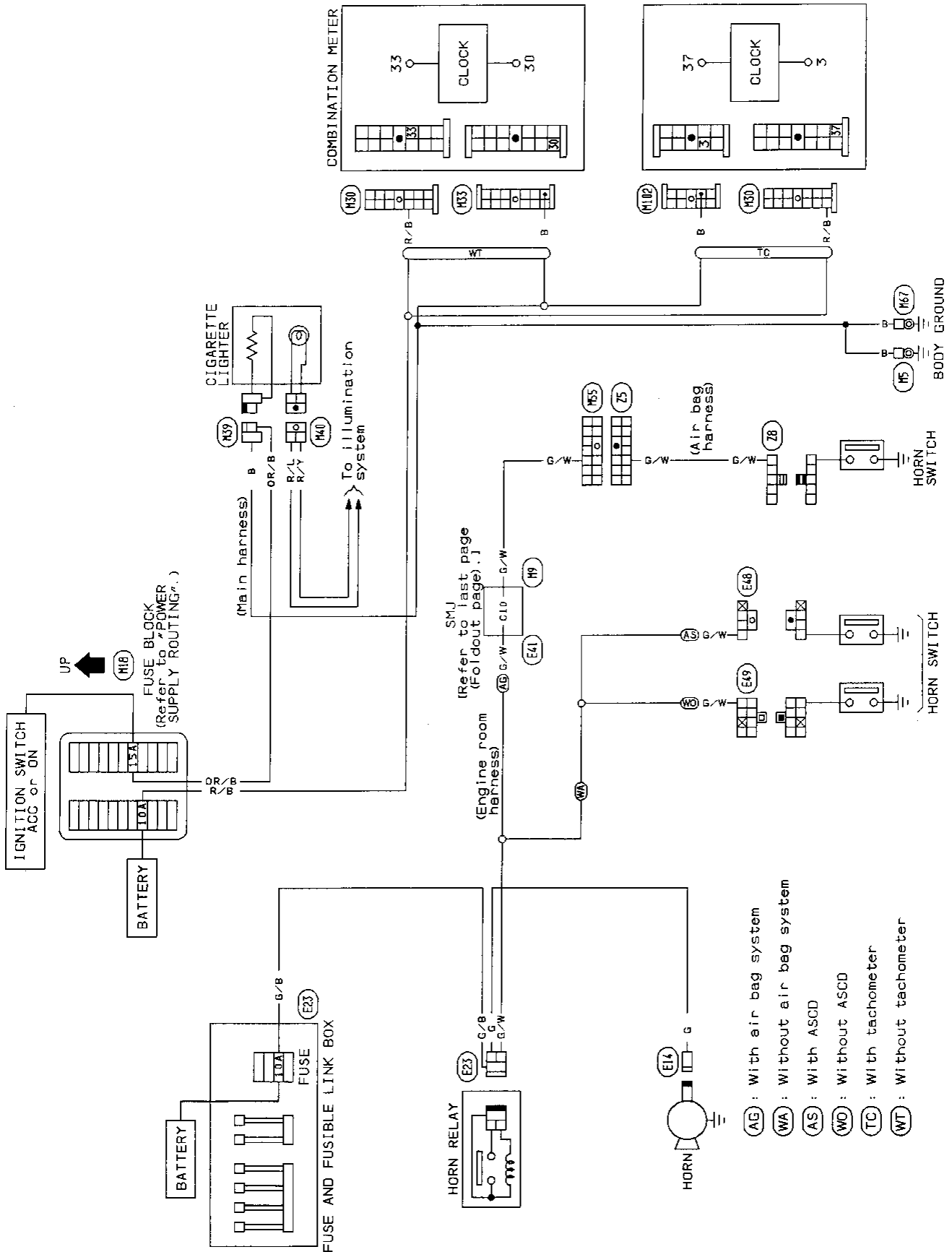

GJ  
 MA  
 EM  
 LC  
 EF &  
 EC  
 FE  
 CL  
 MT  
 AT  
 FA  
 RA  
 BR  
 ST  
 BF  
 HA  
**EL**  
 DX

# AUTOMATIC SPEED CONTROL DEVICE (ASCD)

## Trouble Diagnoses (Cont'd)

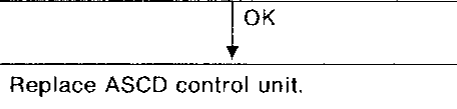
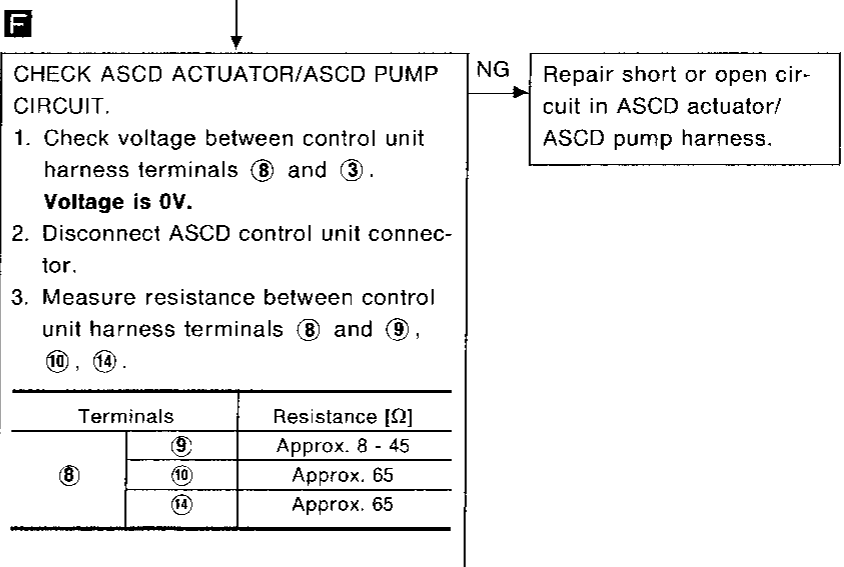
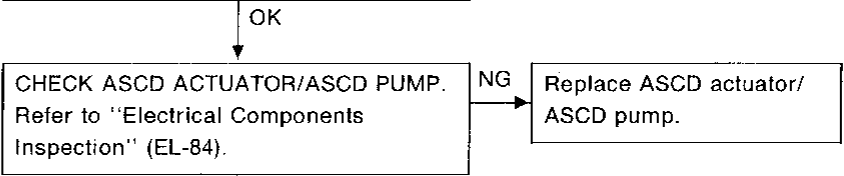
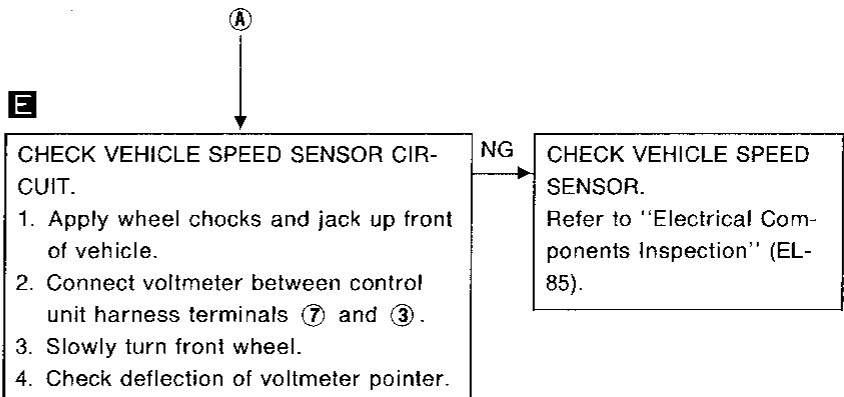
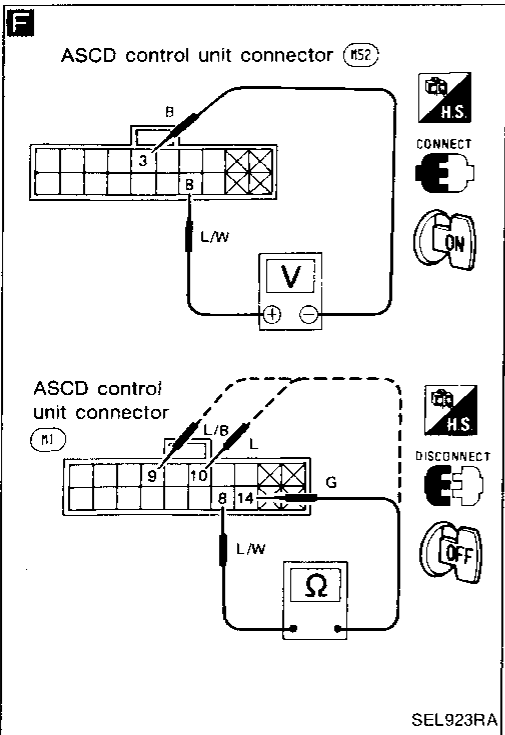
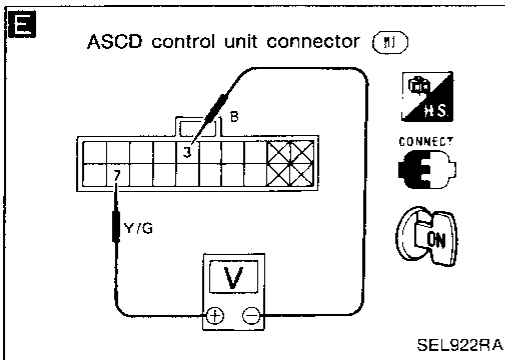

# HARNESS LAYOUT

## Engine Room Harness

### PASSENGER COMPARTMENT

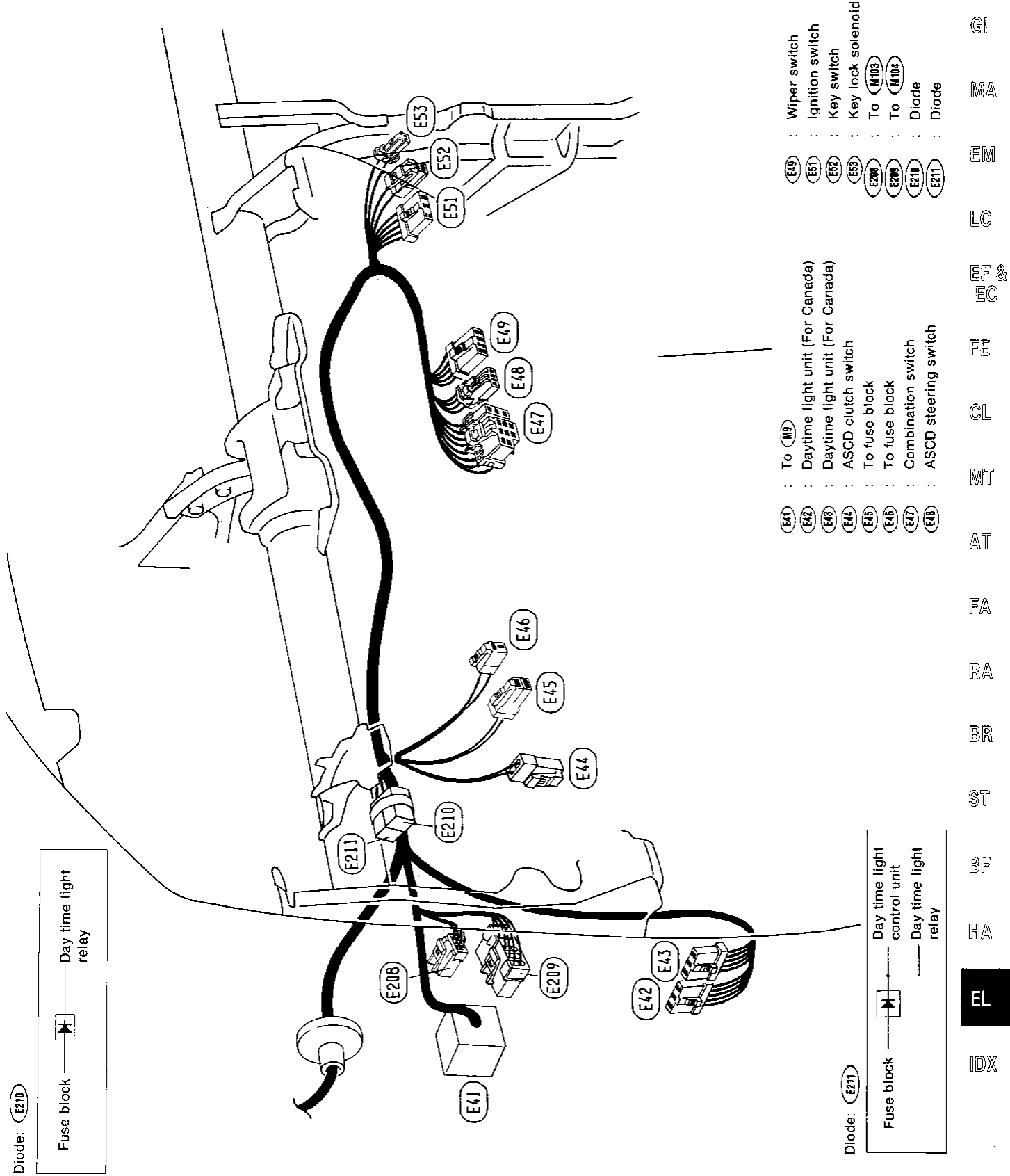

MEL855C

# HARNESS LAYOUT

## Alternator Harness & Engine No. 2 Harness

### GA ENGINE

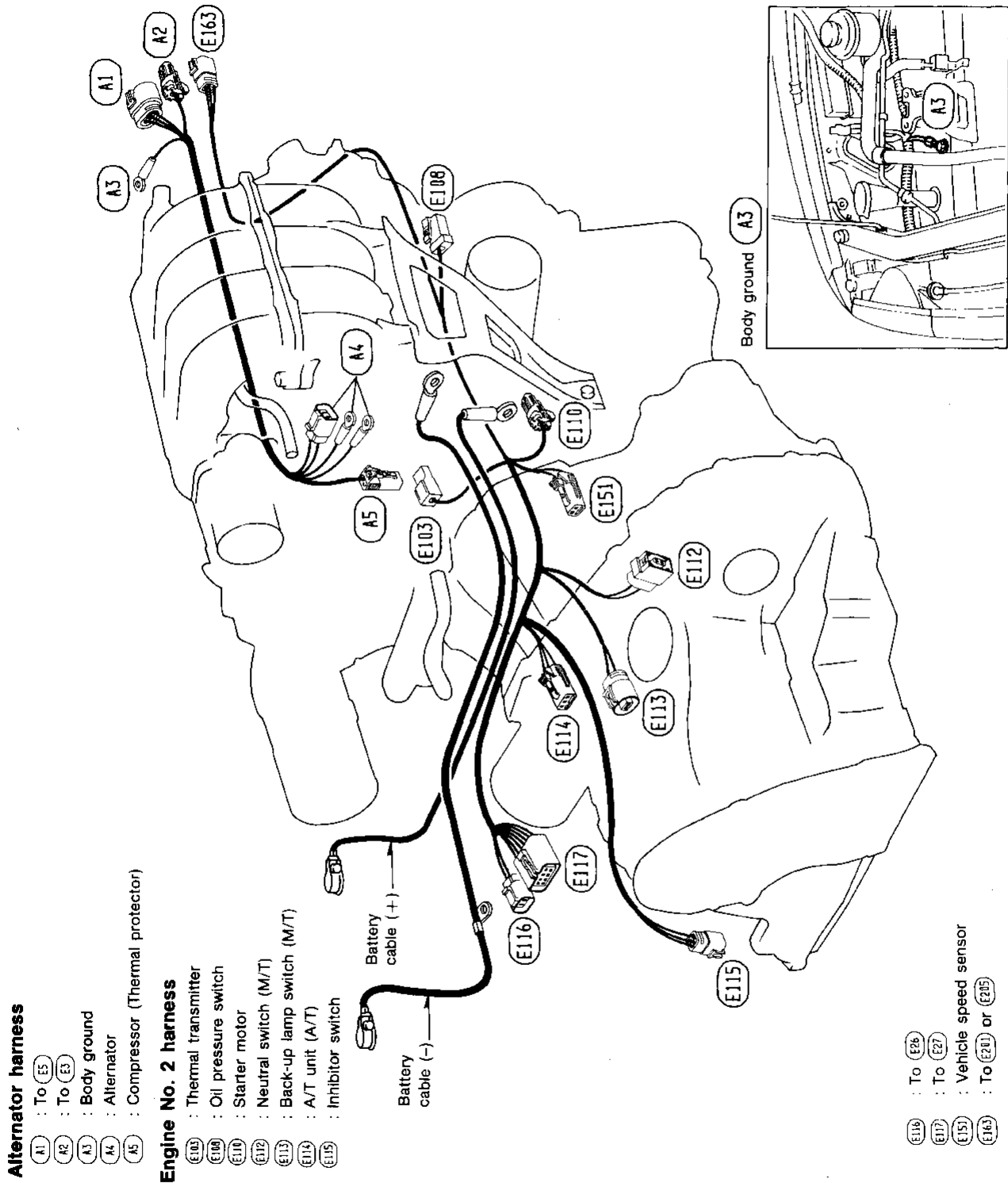

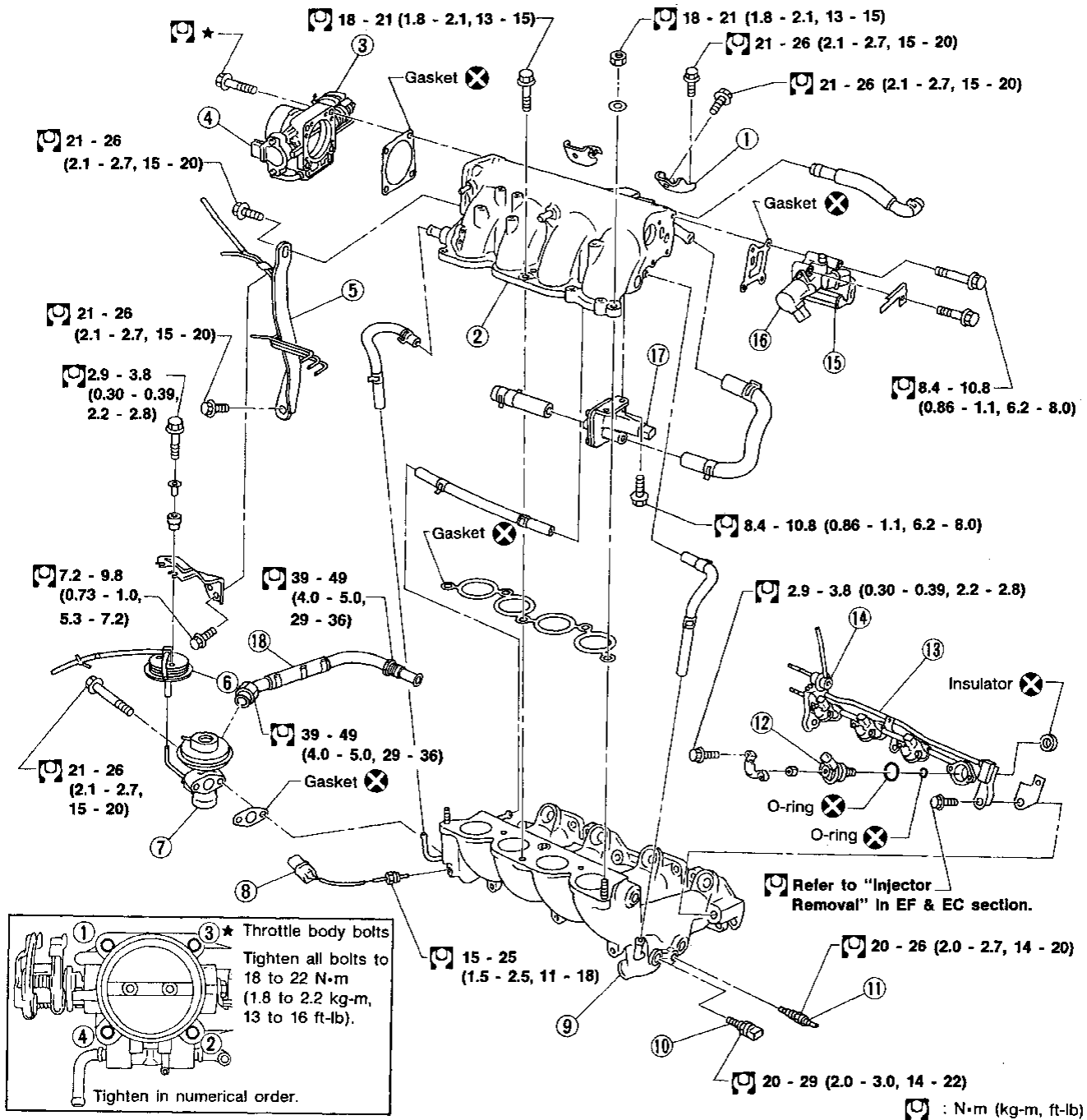

- ① Intake manifold collector support
- ② Intake manifold collector
- ③ Throttle body
- ④ Throttle position sensor
- ⑤ Intake manifold collector support
- ⑥ EGRC-BPT valve

- ⑦ EGR valve
- ⑧ EGR temperature sensor
- ⑨ Intake manifold
- ⑩ Engine coolant temperature sensor
- ⑪ Thermal transmitter
- ⑫ Injector

- ⑬ Fuel tube assembly
- ⑭ Pressure regulator
- ⑮ IACV-FICD valve
- ⑯ IACV-AAC valve
- ⑰ IACV-air regulator
- ⑱ EGR tube

GI

MA

**EM**

LC

EF & EC

FE

CL

MT

AT

FA

RA

BR

ST

BF

SEM715E

HA

EL

IDX

**Removal (Cont'd)**

30. Remove front engine mounting.

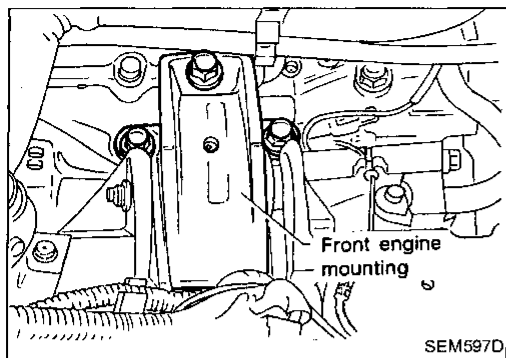

31. Remove front cover.

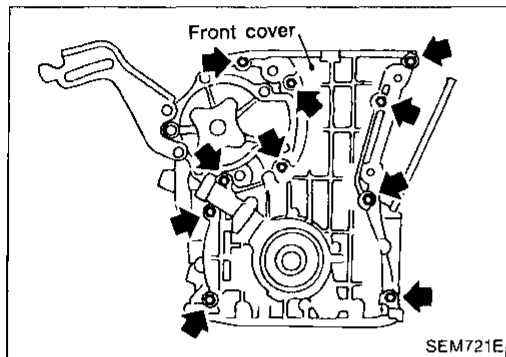

32. Remove timing chain guides and timing chain.

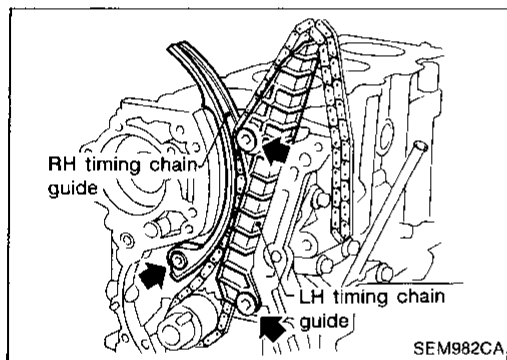

**Inspection**

**Check for cracks and excessive wear at roller links. Replace chain if necessary.**

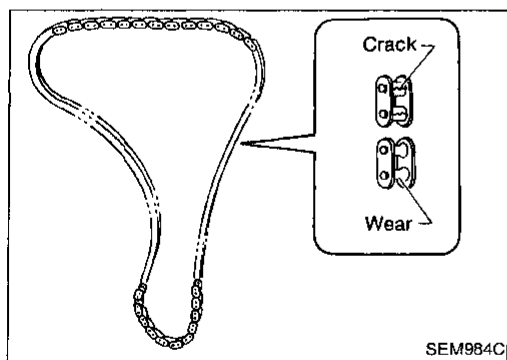

**Installation**

1. Install crankshaft sprocket on crankshaft.

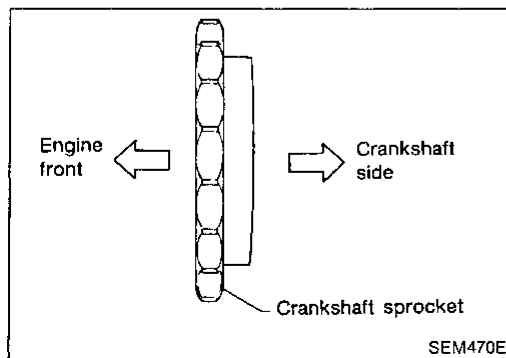

Disassembly (Cont'd)

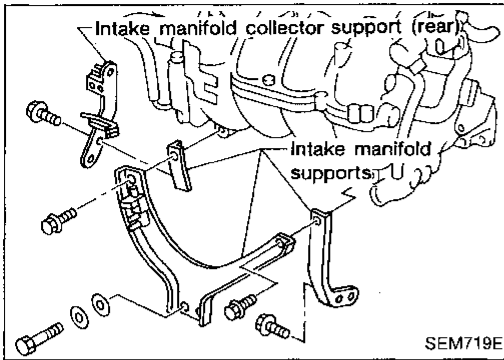

7. Remove intake manifold supports and intake manifold collector supports (both on rear and upper sides).

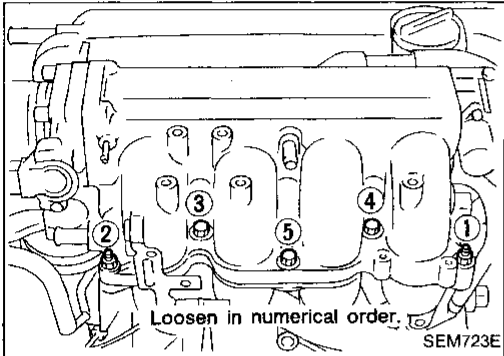

8. Remove intake manifold collector from intake manifold.

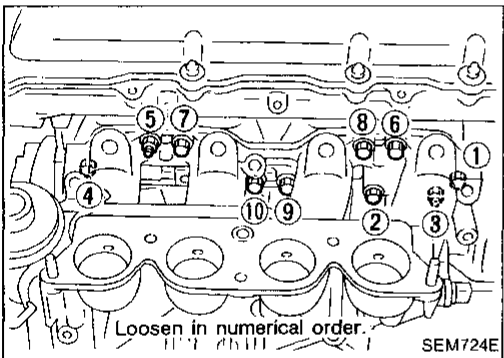

9. Remove fuel tube assembly. Refer to "Injector Removal and Installation" in EF & EC section.
10. Remove power steering oil pump bracket and oil filter bracket.
11. Remove intake manifold.

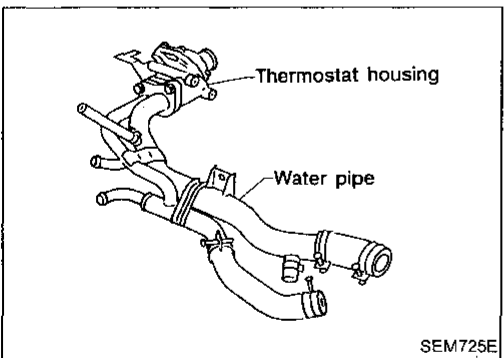

12. Remove thermostat housing with water pipe.

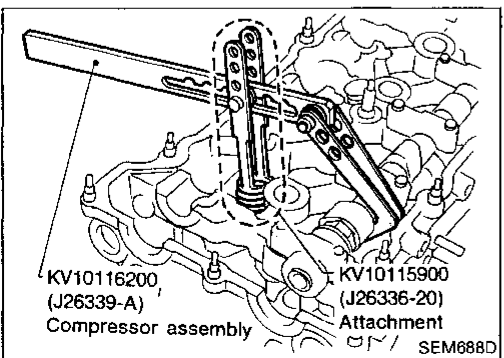

13. Remove valve components with Tool.

GI

MA

EM

LC

EF & EC

FE

CL

MT

AT

FA

RA

BR

ST

BF

HA

EL

IDX

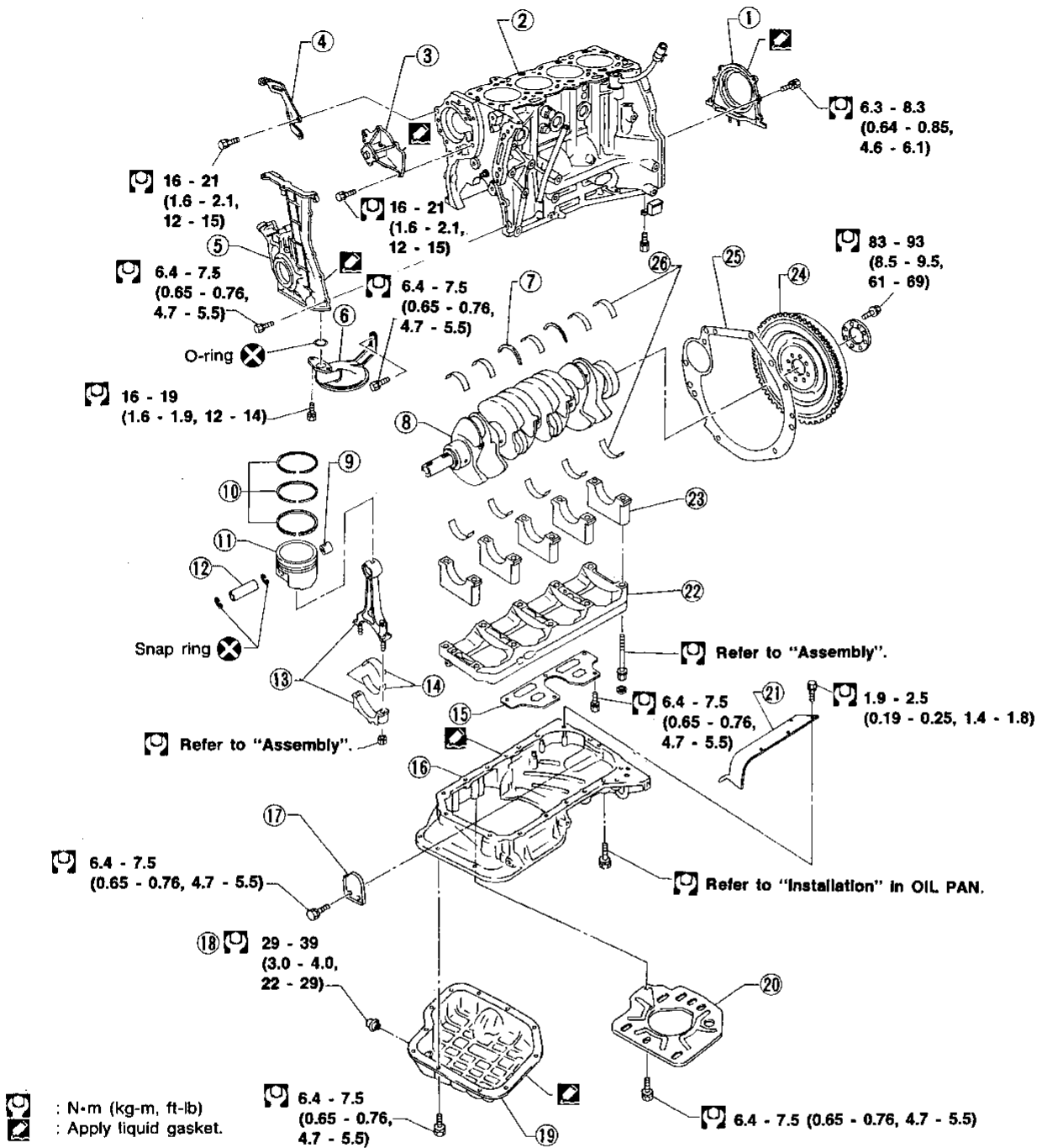

SEM501E

- |  |  |  |
|--|--|--|
| <ul style="list-style-type: none"> <li>① Rear oil seal retainer</li> <li>② Cylinder block</li> <li>③ Water pump</li> <li>④ Power steering oil pump adjusting bar</li> <li>⑤ Front cover with oil pump</li> <li>⑥ Oil strainer</li> <li>⑦ Thrust bearing</li> <li>⑧ Crankshaft</li> <li>⑨ Connecting rod bushing</li> </ul> | <ul style="list-style-type: none"> <li>⑩ Piston rings</li> <li>⑪ Piston</li> <li>⑫ Piston pin</li> <li>⑬ Connecting rod</li> <li>⑭ Connecting rod bearing</li> <li>⑮ Baffle plate</li> <li>⑯ Aluminum oil pan</li> <li>⑰ Rear cover plate</li> <li>⑱ Drain plug</li> </ul> | <ul style="list-style-type: none"> <li>⑲ Steel oil pan</li> <li>⑳ Baffle plate</li> <li>㉑ Side gallery baffle plate</li> <li>㉒ Main bearing beam</li> <li>㉓ Main bearing cap</li> <li>㉔ Flywheel or drive plate</li> <li>㉕ Rear plate</li> <li>㉖ Main bearing</li> </ul> |
|--|--|--|

**Inspection and Adjustment (Cont'd)**

**VALVE**

Unit: mm (in)

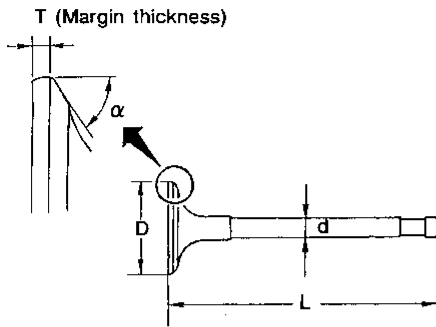

SEM188

<b>Valve head diameter "D"</b>	
Intake	34.0 - 34.2 (1.339 - 1.346)
Exhaust	30.0 - 30.2 (1.181 - 1.189)
<b>Valve length "L"</b>	
Intake	101.19 - 101.61 (3.9839 - 4.0004)
Exhaust	102.11 - 102.53 (4.0201 - 4.0366)
<b>Valve stem diameter "d"</b>	
Intake	5.965 - 5.980 (0.2348 - 0.2354)
Exhaust	5.945 - 5.960 (0.2341 - 0.2346)
<b>Valve seat angle "α"</b>	
Intake	45°15' - 45°45'
Exhaust	
<b>Valve margin "T"</b>	
Intake	1.1 (0.043)
Exhaust	1.3 (0.051)
<b>Valve margin "T" limit</b>	More than 0.5 (0.020)
<b>Valve stem end surface grinding limit</b>	Less than 0.2 (0.008)
<b>Valve clearance</b>	
Intake	0 (0)
Exhaust	0 (0)

**Valve spring**

Free height	mm (in)	49.36 (1.9433)	
Pressure N (kg, lb) at height mm (in)	Standard	569.00 - 641.57 (58.02- 65.42, 127.93 - 144.25) at 30.0 (1.181)	
		Limit	549.2 (56.0, 123.5) at 30.0 (1.181)
		Out-of-square	mm (in)

**Hydraulic lash adjuster (HLA)**

Unit: mm (in)

HLA outer diameter	16.980 - 16.993 (0.6685 - 0.6690)
HLA guide inner diameter	17.000 - 17.020 (0.6693 - 0.6701)
Clearance between HLA and HLA guide	0.007 - 0.040 (0.0003 - 0.0016)

**Valve guide**

Unit: mm (in)

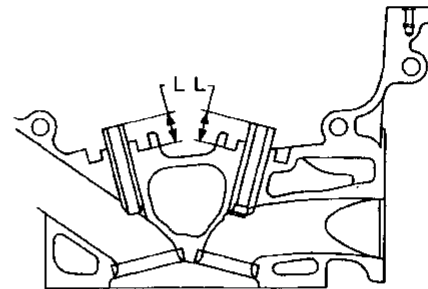

SEM083D

		Standard	Service
Valve guide	Outer diameter	Intake	10.023 - 10.034 (0.3946 - 0.3950)
		Exhaust	10.023 - 10.034 (0.3946 - 0.3950)
Valve guide	Inner diameter (Finished size)	Intake	6.000 - 6.018 (0.2362 - 0.2369)
		Exhaust	6.000 - 6.018 (0.2362 - 0.2369)
Cylinder head valve guide hole diameter	Intake	9.975 - 9.996 (0.3927 - 0.3935)	10.175 - 10.196 (0.4006 - 0.4014)
	Exhaust	9.975 - 9.996 (0.3927 - 0.3935)	10.175 - 10.196 (0.4006 - 0.4014)
Interference fit of valve guide		0.027 - 0.059 (0.0011 - 0.0023)	
		Standard	Limit
Stem to guide clearance	Intake	0.020 - 0.053 (0.0008 - 0.0021)	0.1 (0.004)
	Exhaust	0.040 - 0.073 (0.0016 - 0.0029)	0.1 (0.004)
Valve deflection limit		0.2 (0.008)	
Projection length "L"		14.0 - 14.2 (0.551 - 0.559)	

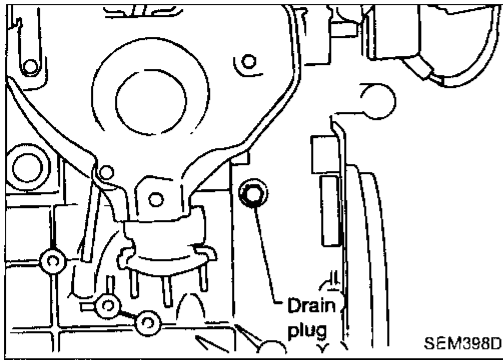

**CAUTION:**

- After removing timing chain, do not turn crankshaft and camshaft separately, or valves will strike piston heads.

**Removal**

1. Drain engine coolant from radiator and cylinder block. Be careful not to spill coolant on drive belts.
2. Release fuel pressure. Refer to "Releasing Fuel Pressure" in EF & EC section.
3. Remove the following belts.
  - Power steering pump drive belt
  - Alternator drive belt
  - Air conditioner drive belt
4. Remove power steering pump bracket.
5. Remove air duct to intake manifold collector.
6. Remove front right-side wheel.
7. Remove front right-side splash cover.
8. Remove front undercovers.
9. Remove front exhaust tube.

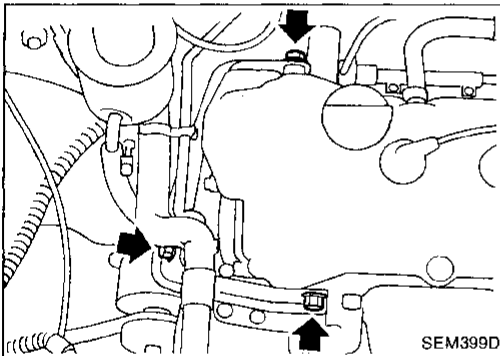

10. Remove engine front mounting bracket.

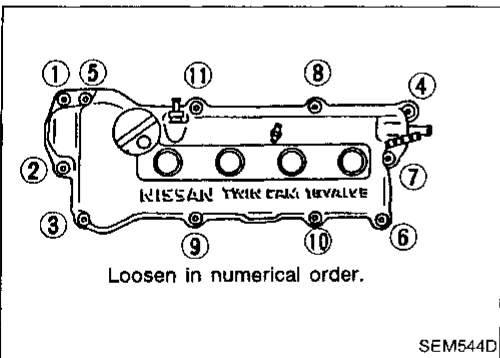

11. Remove rocker cover.
12. Remove distributor cap.
13. Remove all spark plugs.
14. Remove intake manifold support.

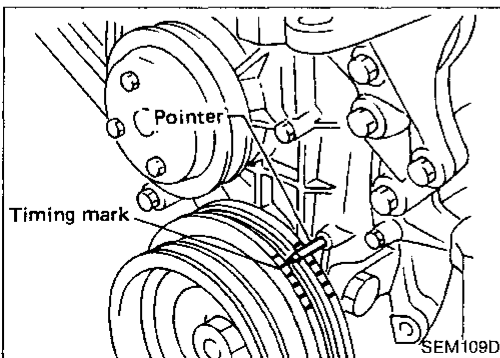

15. Set No. 1 piston at TDC on its compression stroke.

## CYLINDER HEAD

## Inspection (Cont'd)

## CAMSHAFT CAM HEIGHT

1. Measure camshaft cam height.

**Standard cam height:**

**Intake**

40.60 - 40.79 mm (1.5984 - 1.6059 in)

**Exhaust**

39.880 - 40.070 mm (1.5701 - 1.5776 in)

**Cam wear limit:**

0.20 mm (0.0079 in)

2. If wear is beyond the limit, replace camshaft.

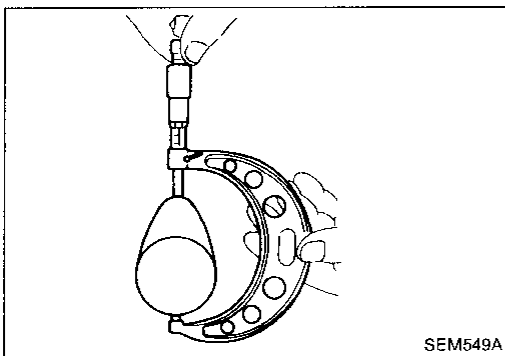

## CAMSHAFT JOURNAL CLEARANCE

1. Install camshaft bracket and tighten bolts to the specified torque.

2. Measure inner diameter of camshaft bearing.

**Standard inner diameter:**

**No. 1 bearing**

28.000 - 28.021 mm (1.1024 - 1.1032 in)

**No. 2 to No. 5 bearings**

24.000 - 24.021 mm (0.9449 - 0.9457 in)

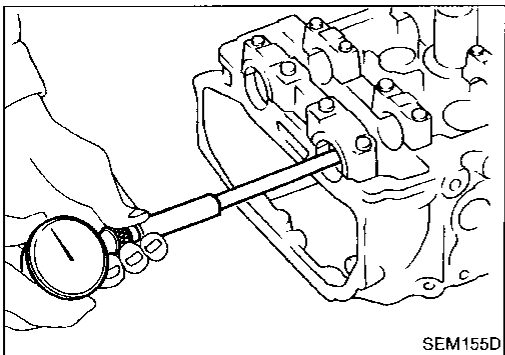

3. Measure outer diameter of camshaft journal.

**Standard outer diameter:**

**No. 1 journal**

27.935 - 27.955 mm (1.0998 - 1.1006 in)

**No. 2 to No. 5 journals**

23.935 - 23.955 mm (0.9423 - 0.9431 in)

4. If clearance exceeds the limit, replace camshaft and/or cylinder head.

**Camshaft journal clearance:**

**Standard 0.045 - 0.086 mm (0.0018 - 0.0034 in)**

**Limit 0.15 mm (0.0059 in)**

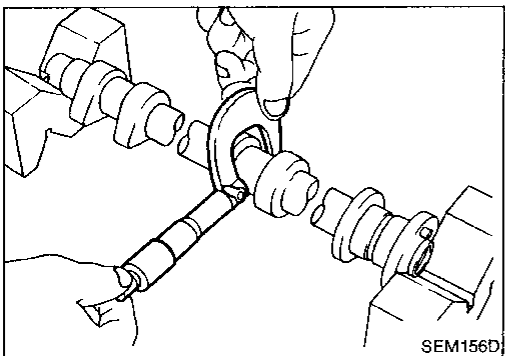

## CAMSHAFT END PLAY

1. Install camshaft in cylinder head.

2. Measure camshaft end play.

**Camshaft end play:**

**Standard**

0.070 - 0.143 mm (0.0028 - 0.0056 in)

**Limit**

0.20 mm (0.0079 in)

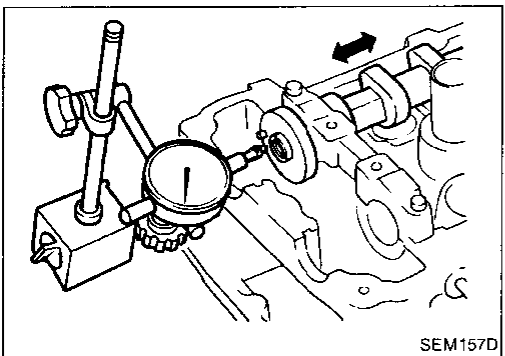

## CAMSHAFT SPROCKET RUNOUT

1. Install sprocket on camshaft.

2. Measure camshaft sprocket runout.

**Runout (Total indicator reading):**

**Limit 0.15 mm (0.0059 in)**

3. If it exceeds the limit, replace camshaft sprocket.

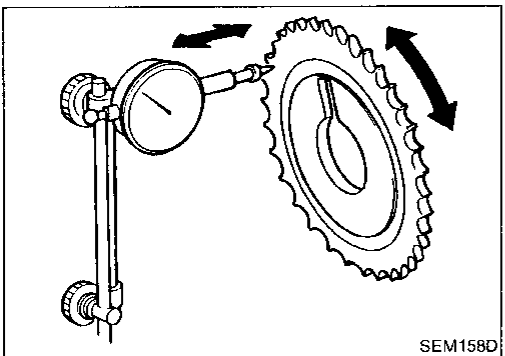

## Inspection (Cont'd)

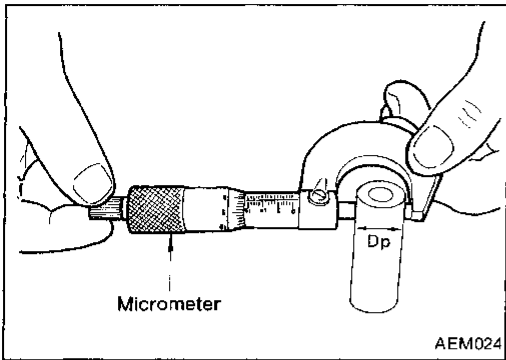

2. Measure outer diameter of piston pin "Dp".

**Standard diameter "Dp":**

**18.989 - 19.001 mm (0.7476 - 0.7481 in)**

3. Calculate piston pin clearance.

**$dp - Dp = -0.004$  to  $0$  mm ( $-0.0002$  to  $0$  in)**

If it exceeds the above value, replace piston assembly with pin.

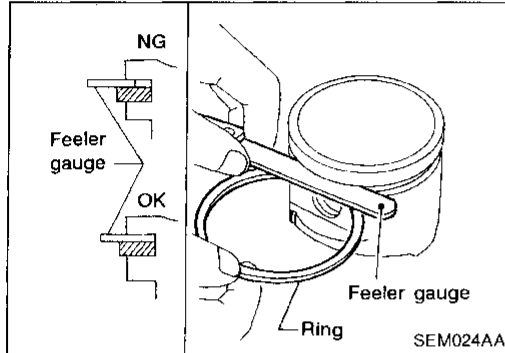

## PISTON RING SIDE CLEARANCE

**Side clearance:**

**Top ring**

**0.040 - 0.080 mm (0.0016 - 0.0031 in)**

**2nd ring**

**0.030 - 0.070 mm (0.0012 - 0.0028 in)**

**Max. limit of side clearance:**

**0.2 mm (0.008 in)**

If out of specification, replace piston and/or piston ring assembly.

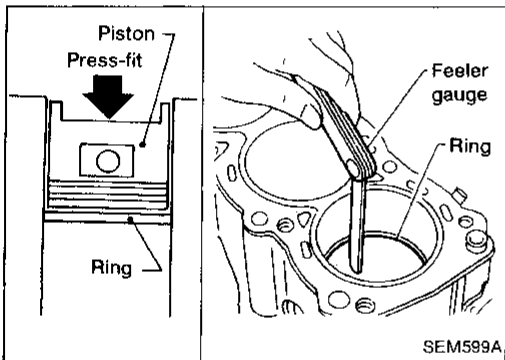

## PISTON RING END GAP

**End gap:**

**Top ring 0.20 - 0.35 mm (0.0079 - 0.0138 in)**

**2nd ring 0.37 - 0.52 mm (0.0146 - 0.0205 in)**

**Oil ring 0.20 - 0.60 mm (0.0079 - 0.0236 in)**

**Max. limit of ring gap:**

**1.0 mm (0.039 in)**

If out of specification, replace piston ring. If gap still exceeds the limit even with a new ring, rebore cylinder and use oversized piston and piston rings.

**Refer to SDS (EM-113).**

- When replacing the piston, check the cylinder block surface for scratches or seizure. If scratches or seizure is found, hone or replace the cylinder block.

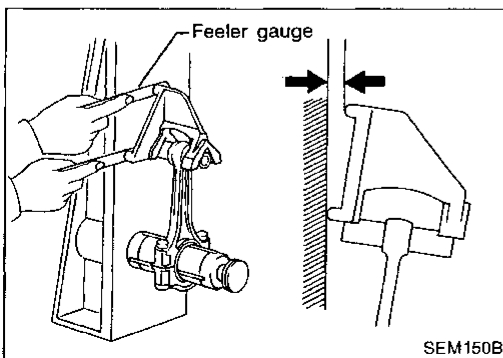

## CONNECTING ROD BEND AND TORSION

**Bend limit:**

**0.15 mm (0.0059 in)**

**per 100 mm (3.94 in) length**

**Torsion limit:**

**0.3 mm (0.012 in)**

**per 100 mm (3.94 in) length**

If it exceeds the limit, replace connecting rod assembly.

Inspection and Adjustment (Cont'd)

PISTON, PISTON RING AND PISTON PIN

Piston pin

Piston

Unit: mm (in)

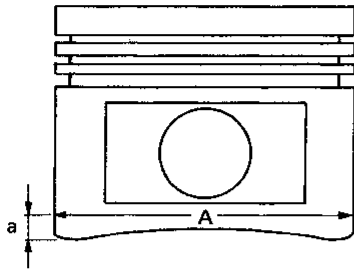

SEM416D

Piston skirt diameter "A"	
Standard	
Grade No. 1	75.975 - 75.985 (2.9911 - 2.9915)
Grade No. 2	75.985 - 75.995 (2.9915 - 2.9919)
Grade No. 3	75.995 - 76.005 (2.9919 - 2.9923)
0.5 (0.020) oversize (service)	76.475 - 76.505 (3.0108 - 3.0120)
1.0 (0.039) oversize (service)	76.975 - 77.005 (3.0305 - 3.0317)
"a" dimension	9.5 (0.374)
Piston pin hole inner diameter	18.987 - 18.999 (0.7475 - 0.7480)
Piston pin outer diameter	18.989 - 19.001 (0.7476 - 0.7481)
Piston to bore clearance	0.015 - 0.035 (0.0006 - 0.0014)

Piston ring

Unit: mm (in)

		Standard	Limit
Side clearance	Top	0.040 - 0.080 (0.0016 - 0.0031)	0.2 (0.008)
	2nd	0.030 - 0.070 (0.0012 - 0.0028)	
End gap	Top	0.20 - 0.35 (0.0079 - 0.0138)	1.0 (0.039)
	2nd	0.37 - 0.52 (0.0146 - 0.0205)	
	Oil	0.20 - 0.60 (0.0079 - 0.0236)	

Unit: mm (in)

Piston pin outer diameter	18.989 - 19.001 (0.7476 - 0.7481)
Piston pin to piston clearance	- 0.004 to 0 (- 0.0002 to 0)
Piston pin to connecting rod, bushing clearance	0.005 - 0.017 (0.0002 - 0.0007)

CONNECTING ROD

Unit: mm (in)

Center distance	140.45 - 140.55 (5.5295 - 5.5335)
Bend limit [per 100 (3.94)]	0.15 (0.0059)
Torsion limit [per 100 (3.94)]	0.3 (0.012)
Connecting rod bushing inner diameter* (small end)	19.000 - 19.012 (0.7480 - 0.7485)
Connecting rod big end inner diameter	43.000 - 43.013 (1.6929 - 1.6934)
Side clearance	
Standard	0.20 - 0.47 (0.0079 - 0.0185)
Limit	0.52 (0.0205)

\*: After installing in connecting rod

CRANKSHAFT

Unit: mm (in)

Main journal dia. "Dm"	
Grade No. 0	49.956 - 49.964 (1.9668 - 1.9671)
Grade No. 1	49.948 - 49.956 (1.9665 - 1.9668)
Grade No. 2	49.940 - 49.948 (1.9661 - 1.9665)
Pin journal dia. "Dp"	
Grade No. 0	39.968 - 39.974 (1.5735 - 1.5738)
Grade No. 1	39.962 - 39.968 (1.5733 - 1.5735)
Grade No. 2	39.956 - 39.962 (1.5731 - 1.5733)
Center distance "r"	43.95 - 44.05 (1.7303 - 1.7342)
Out-of-round (X - Y)	
Standard	Less than 0.005 (0.0002)
Taper (A - B)	
Standard	Less than 0.002 (0.0001)
Runout [TIR*]	
Standard	Less than 0.05 (0.0020)
Free end play	
Standard	0.060 - 0.180 (0.0024 - 0.0071)
Limit	0.3 (0.012)

\*: Total indicator reading

## FRONT AXLE

### Wheel Hub and Knuckle (Cont'd)

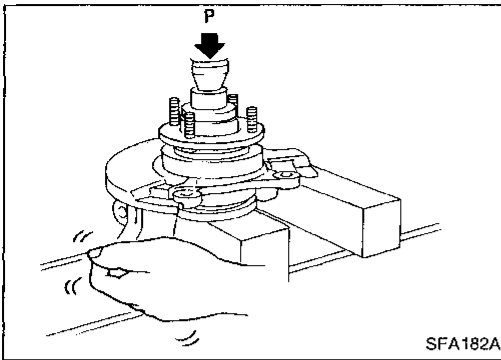

- b. Spin knuckle several turns in both directions.
- c. Make sure that wheel bearings operate smoothly.

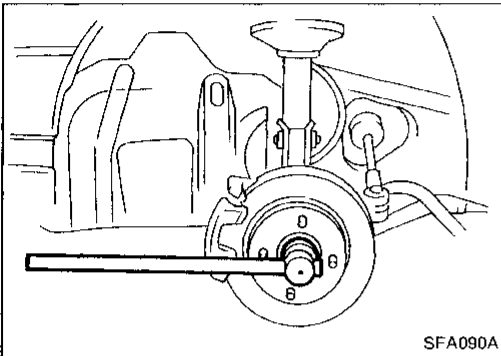

### Drive Shaft

#### REMOVAL

- Remove wheel bearing lock nut.
- Remove brake caliper assembly.

**Brake hose need not be disconnected from brake caliper. Be careful not to depress brake pedal, or piston will pop out.**

**Do not puller or twist brake hose.**

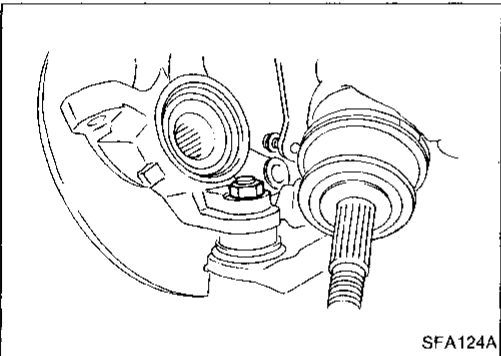

- Remove tie-rod ball joint.
- Separate drive shaft from knuckle by lightly tapping it. If it is hard to remove, use a puller.

**When removing drive shaft, cover boots with shop towel to prevent damage to them.**

Refer to FRONT AXLE — Wheel Hub and Knuckle. (FA-8)

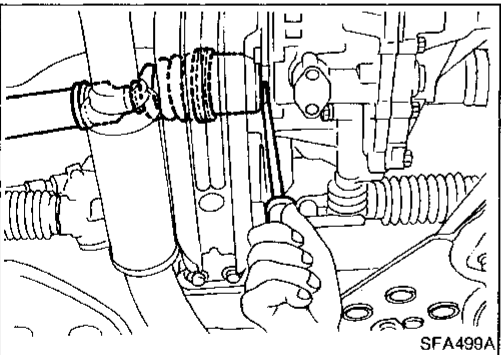

1. Remove right drive shaft from transaxle.

— Models without support bearing —

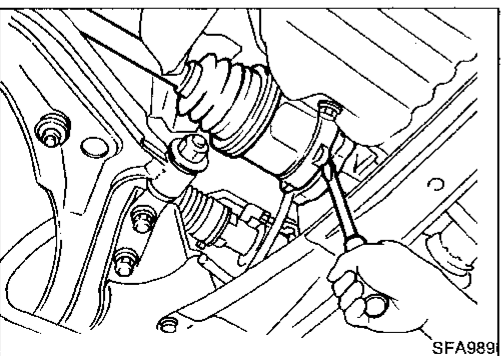

— Models with support bearing —

# FRONT SUSPENSION

## Transverse Link and Lower Ball Joint (Cont'd)

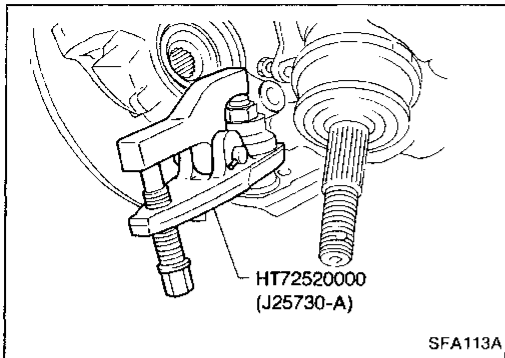

5. Separate lower ball joint stud from knuckle with Tool.  
Refer to FRONT AXLE — Wheel Hub and Knuckle. (FA-8)

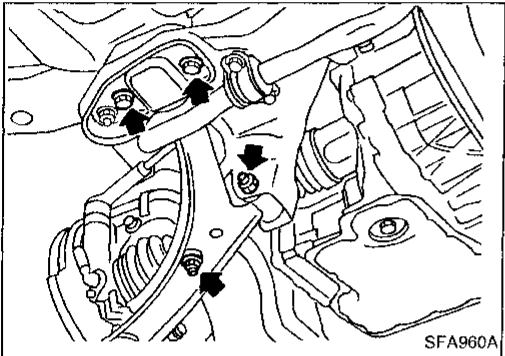

6. Remove bolts and nuts as shown at left.

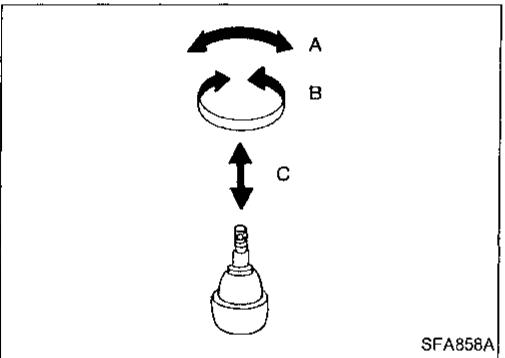

### INSPECTION

- Check ball joint for play. If ball stud is worn, play in axial direction is excessive or joint is hard to swing, replace lower ball joint.  
Before checking, turn ball joint at least 10 revolutions so that ball joint is properly broken in.

#### Swinging force "A":

(measuring point: cotter pin hole of ball stud)

7.8 - 57.9 N (0.8 - 5.9 kg, 1.8 - 13.0 lb)

#### Turning torque "B":

0.5 - 3.4 N·m (5 - 35 kg-cm, 4.3 - 30.4 in-lb)

#### Vertical end play "C":

0 mm (0 in)

- Check dust cover for damage. Replace it and cover clamp if necessary.

GI

MA

EM

LC

EF &  
EC

FE

CL

MT

AT

FA

RA

BR

ST

BF

HA

EL

IDX

## PRECAUTIONS

### Engine Oils (Cont'd)

6. First Aid treatment should be obtained immediately for open cuts and wounds.
7. Use barrier creams, applying them before each work period, to help the removal of oil from the skin.
8. Wash with soap and water to ensure all oil is removed (skin cleansers and nail brushes will help). Preparations containing lanolin replace the natural skin oils which have been removed.
9. Do not use gasoline, kerosine, diesel fuel, gas oil, thinners or solvents for cleaning skin.
10. If skin disorders develop, obtain medical advice without delay.
11. Where practicable, degrease components prior to handling.
12. Where there is a risk of eye contact, eye protection should be worn, for example, chemical goggles or face shields; in addition an eye wash facility should be provided.

GI

MA

EM

LC

EF &  
EC

### ENVIRONMENTAL PROTECTION PRECAUTIONS

Burning used engine oil in small space heaters or boilers can be recommended only for units of approved design. The heating system must meet the requirements of HM Inspectorate of Pollution for small burners of less than 0.4 MW. If in doubt check with the appropriate local authority and/or manufacturer of the approved appliance.

FE

CL

Dispose of used oil and used oil filters through authorized waste disposal contractors to licensed waste disposal sites, or to the waste oil reclamation trade. If in doubt, contact the local authority for advice on disposal facilities.

MT

It is illegal to pour used oil on to the ground, down sewers or drains, or into water courses.

AT

**The regulations concerning the pollution of the environment will vary from country to country.**

FA

### Precautions for Fuel

RA

Use unleaded gasoline with an octane rating of at least 87 AKI (Anti-Knock Index) number (research octane number 91).

BR

#### **CAUTION:**

**Do not use leaded gasoline. Using leaded gasoline will damage the three way catalyst.**

ST

BF

HA

EL

IDX

# IDENTIFICATION INFORMATION

## Identification Number (Cont'd) IDENTIFICATION PLATE

NISSAN MOTOR CO., LTD. JAPAN		
型式	TYPE TIPO	△
CHASSIS NO. NO. OF CHASSIS		△
MODEL MODELO		△
○ カラー COLOR TRIM トリム COLOR GUARNICION		△ △ ○
エンジン ENGINE ジン MOTOR		△ △ CC
ミッション TRANS. AXLE アクスル TRANS. EA		△ △
	工場 PLANT PLANTA	
日産自動車株式会社		MADE IN JAPAN

- 1 Type
- 2 Vehicle identification number (Chassis number)
- 3 Model
- 4 Body color code
- 5 Trim color code
- 6 Engine model
- 7 Engine displacement
- 8 Transmission model
- 9 Axle model

SGI315

### ENGINE SERIAL NUMBER

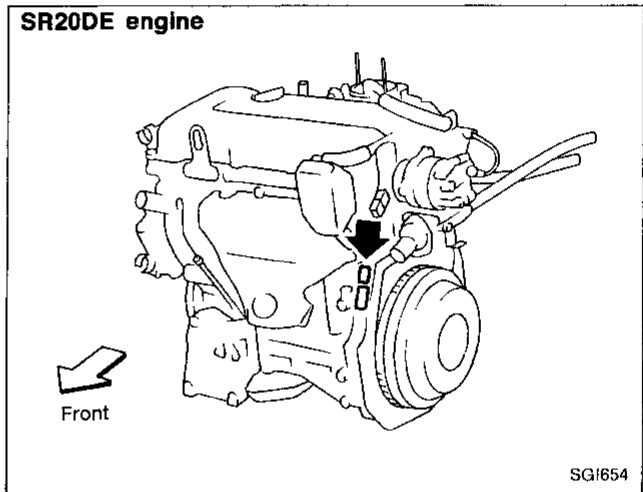
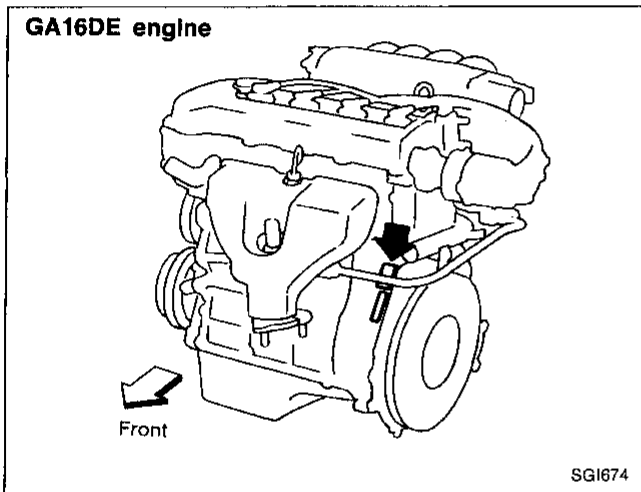

### MANUAL TRANSAXLE NUMBER

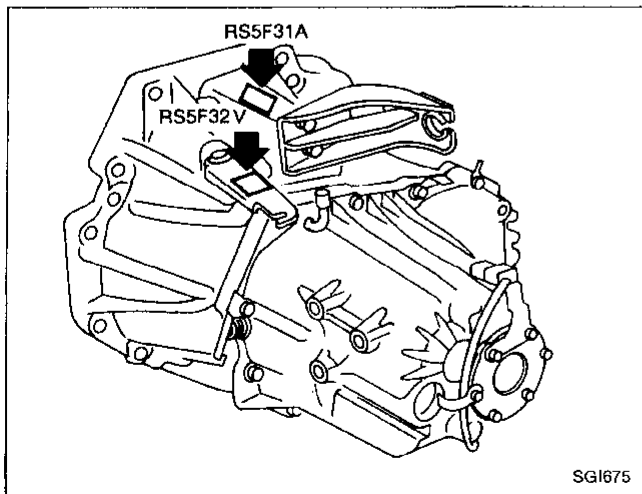

### AUTOMATIC TRANSAXLE NUMBER

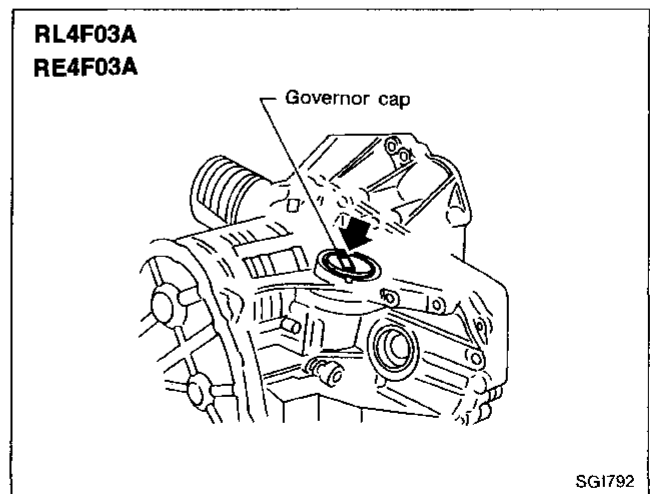

# PRECAUTIONS

## Supplemental Restraint System "AIR BAG"

The Supplemental Restraint System "Air Bag" helps to reduce the risk or severity of injury to the driver in a frontal collision. The Supplemental Restraint System consists of an air bag (located in the center of the steering wheel), sensors, a control unit, warning lamp, wiring harness and spiral cable. Information necessary to service the system safely is included in the **BF section** of this Service Manual.

### WARNING:

- a. To avoid rendering the SRS inoperative, which could lead to personal injury or death in the event of a severe frontal collision, all maintenance must be performed by an authorized NISSAN dealer.
- b. Improper maintenance, including incorrect removal and installation of the SRS, can lead to personal injury caused by unintentional activation of the system.
- c. All SRS electrical wiring harnesses and connectors are covered with yellow outer insulation. Do not use electrical test equipment on any circuit related to the SRS "Air Bag".

## Introduction

To prevent the ozone layer from being destroyed, the HFC-134a (R-134a) refrigerant has replaced the previously used CFC-12 (R-12).

The new and previous service tools, refrigerant, lubricant, etc. are not interchangeable due to differences in their physical properties and characteristics.

Always service the HFC-134a (R-134a) air conditioning system using the specified tools, lubricant and refrigerant, observing the following precautions:

## Identification

### IDENTIFICATION LABEL FOR VEHICLE

AIR CONDITIONER		NISSAN
	REFRIGERANT	COMPRESSOR LUBRICANT
TYPE (PART NO.)	R134a	①
AMOUNT	③	②

**CAUTION PRÉCAUTION**

- REFRIGERANT UNDER HIGH PRESSURE
- SYSTEM TO BE SERVICED BY QUALIFIED PERSONNEL
- IMPROPER SERVICE METHODS MAY CAUSE PERSONAL INJURY.
- CONSULT SERVICE MANUAL.
- THIS AIR CONDITIONER SYSTEM COMPLIES WITH SAE J-639.

NISSAN MOTOR CO., LTD. Tokyo, Japan

- ① : Lubricant type and service part number
- ② : Amount of lubricant
- ③ : Amount of refrigerant

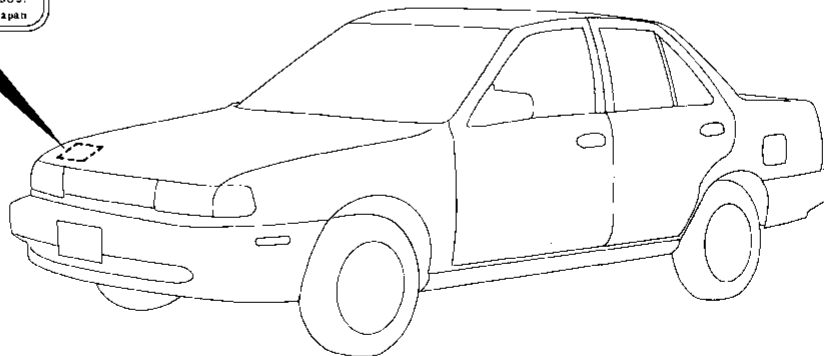

RHA194E

# SERVICE PROCEDURES

## HFC-134a (R-134a) Service Procedure

### SETTING OF SERVICE TOOLS AND EQUIPMENT

#### DISCHARGING REFRIGERANT

##### WARNING:

Avoid breathing A/C refrigerant and lubrication oil vapor or mist. Exposure may irritate eyes, nose and throat. Use only approved recovery/recycling equipment to discharge HFC-134a (R-134a) systems. If accidental system discharge occurs, ventilate work area before resuming work.

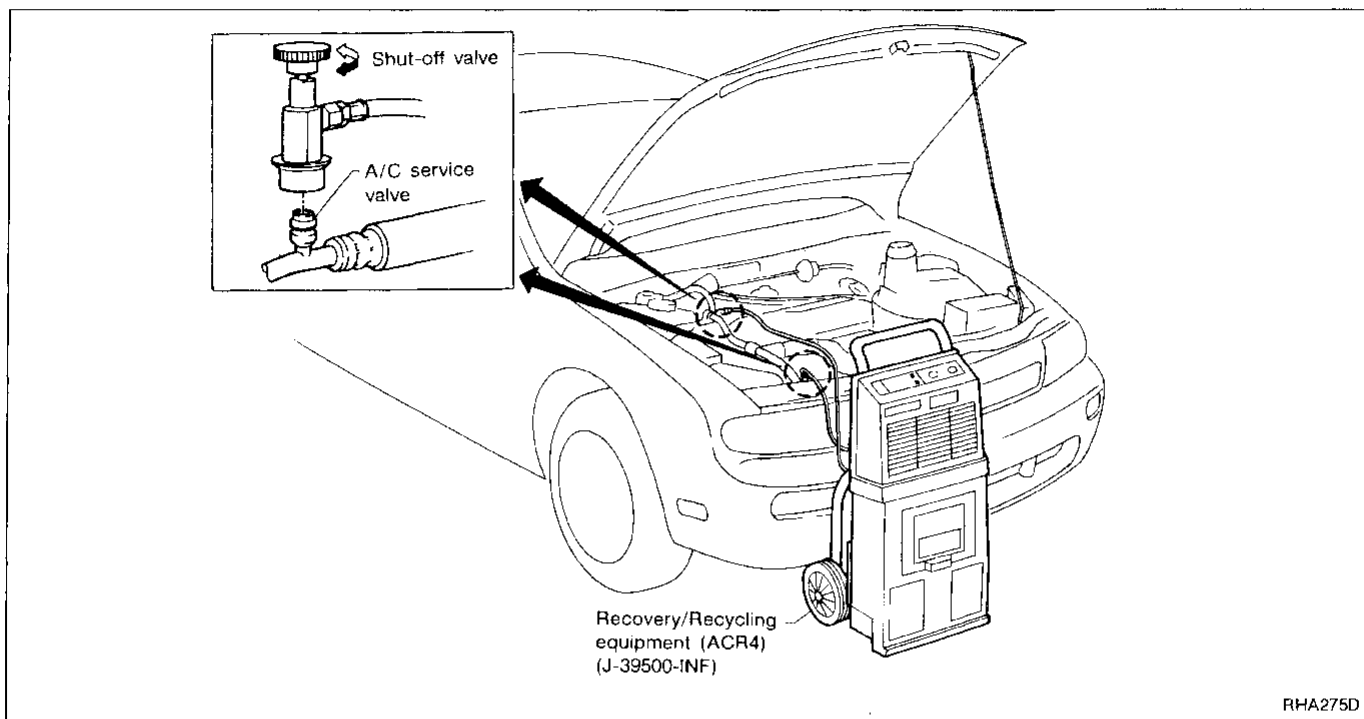

#### EVACUATING SYSTEM AND CHARGING REFRIGERANT

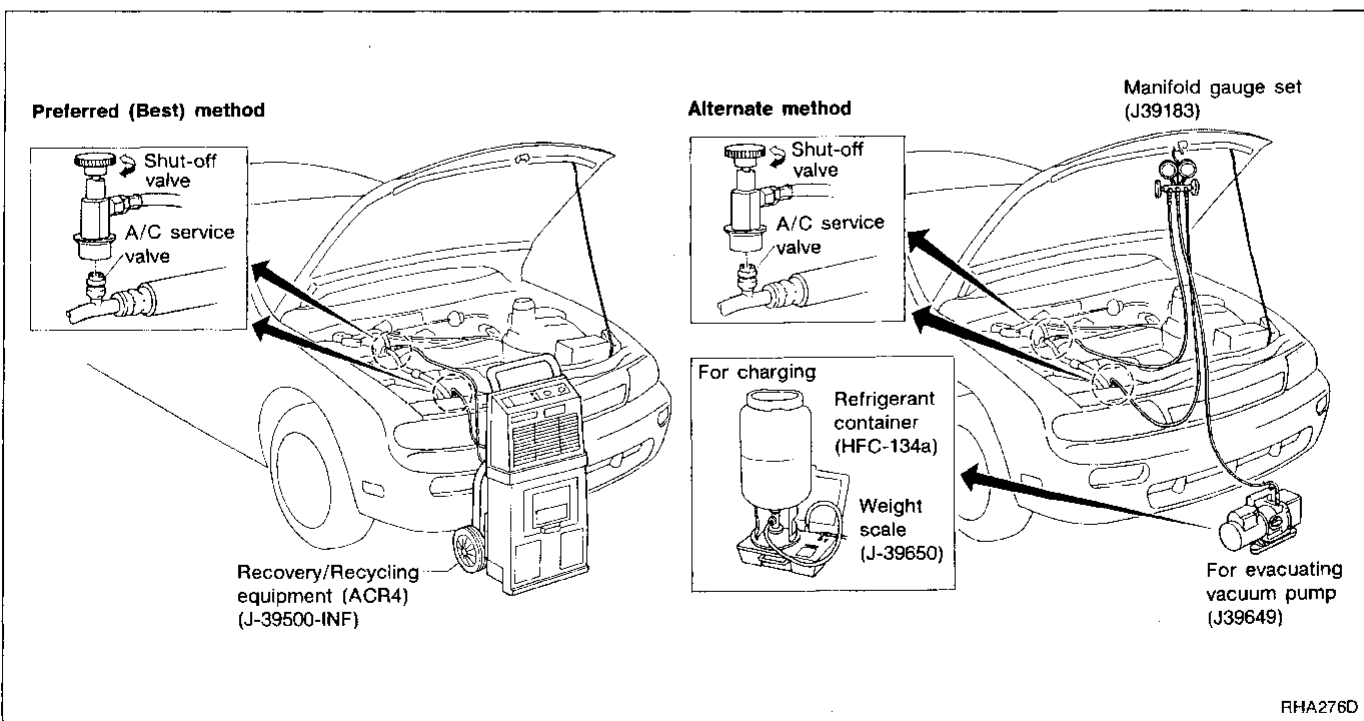

## DIAGNOSES — Overall System

### Operational Check (Cont'd)

#### 4. Check temperature decrease

- 1) Slide temperature control lever to full cold.
- 2) Check for cold air at discharge air outlets.

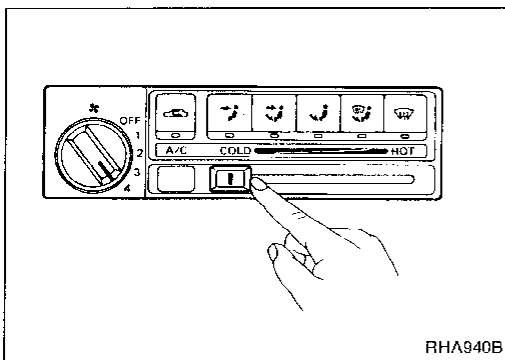

#### 5. Check temperature increase

- 1) Slide temperature control lever to full hot.
- 2) Check for hot air at discharge air outlets.

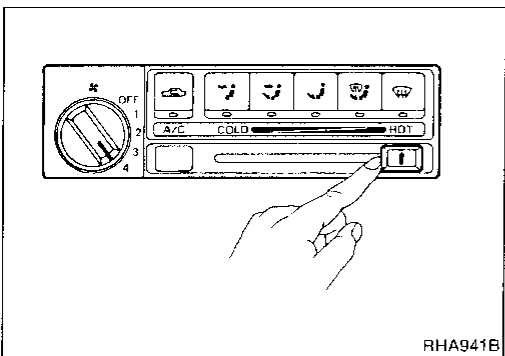

#### 6. Check air conditioner switch

Move the fan control lever to the desired (1 to 4-speed) position and push the air conditioner button to turn ON the air conditioner.

The indicator light should come on when air conditioner is ON.

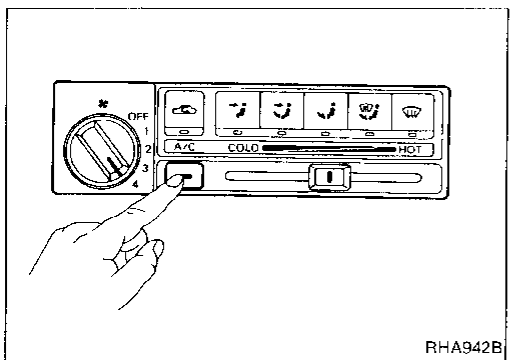

# TROUBLE DIAGNOSES

## Preliminary Check (Cont'd)

### PRELIMINARY CHECK 5

#### Noise

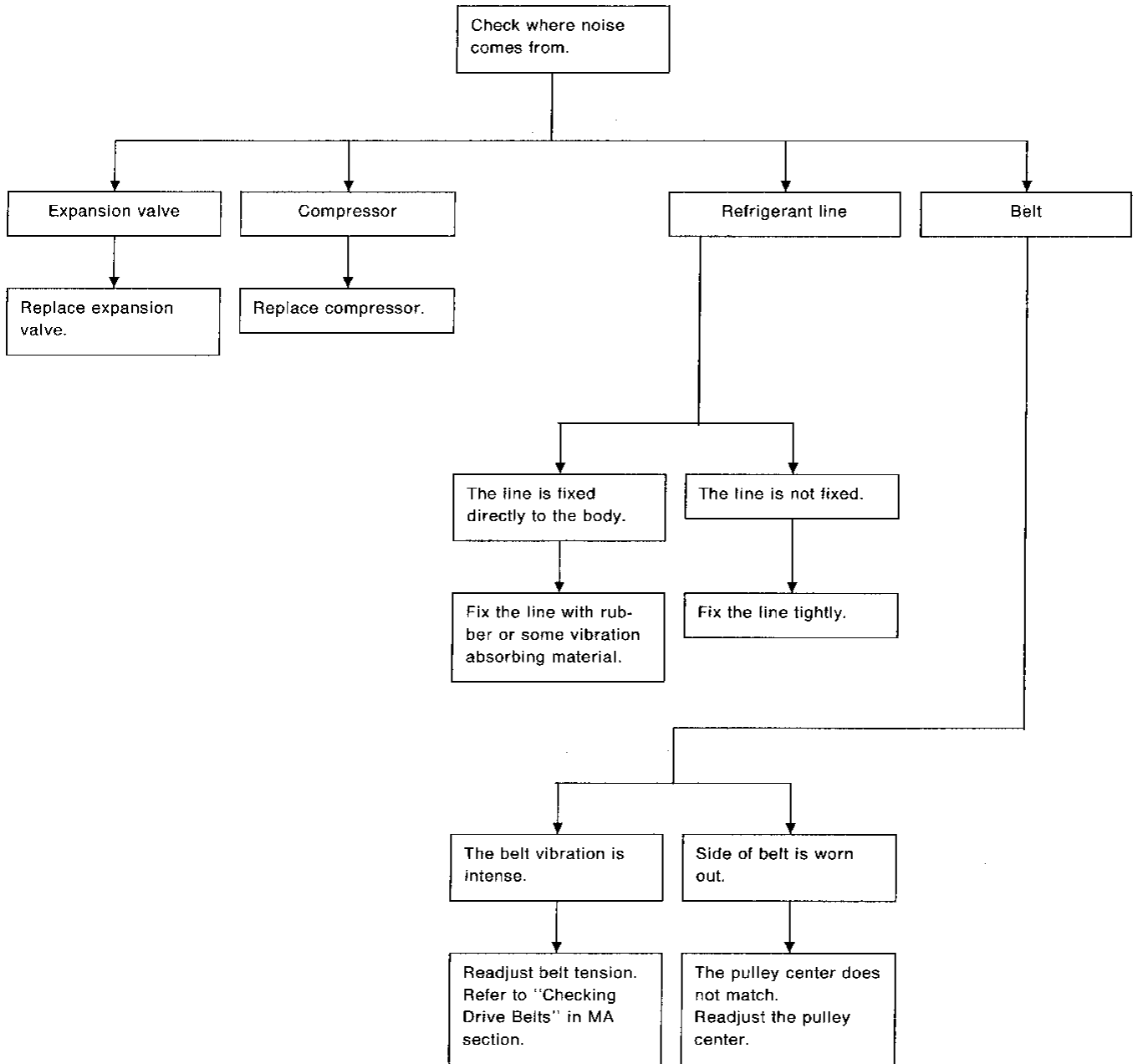

GI

MA

EM

LC

EF &  
EC

FE

CL

MT

AT

FA

RA

BR

ST

BF

**HA**

EL

IDX

# TROUBLE DIAGNOSES

	INCIDENT	Flow chart No.
1	Fan fails to rotate.	1
2	Fan does not rotate at 1-speed.	2
3	Fan does not rotate at 2-speed.	3
4	Fan does not rotate at 3-speed.	4
5	Fan does not rotate at 4-speed.	5

## Diagnostic Procedure 1

### SYMPTOM: Blower motor does not rotate.

- Perform **PRELIMINARY CHECK 2** before referring to the following flow chart.

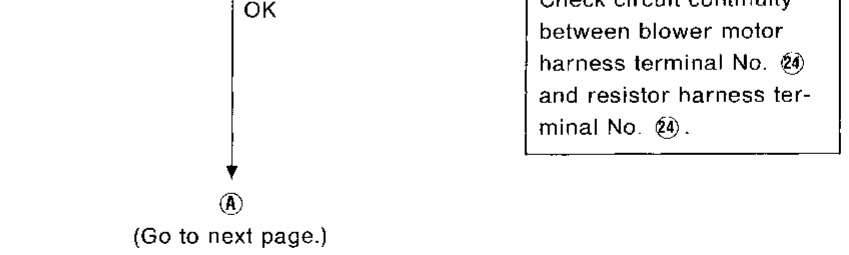
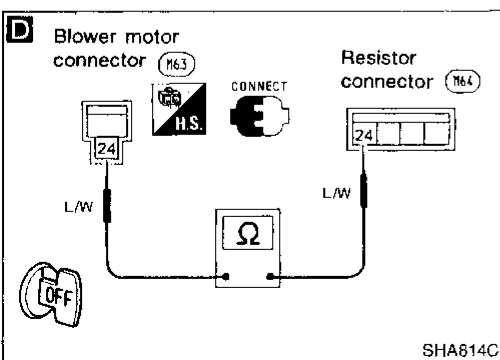
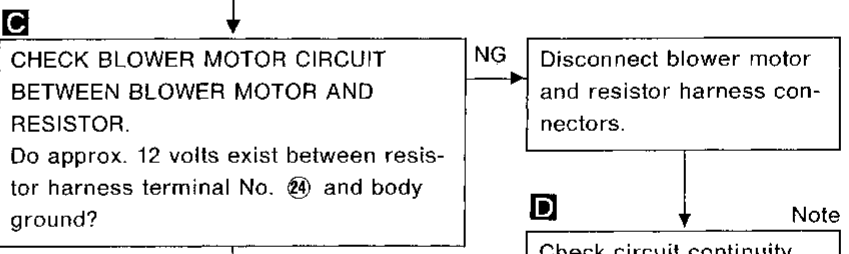
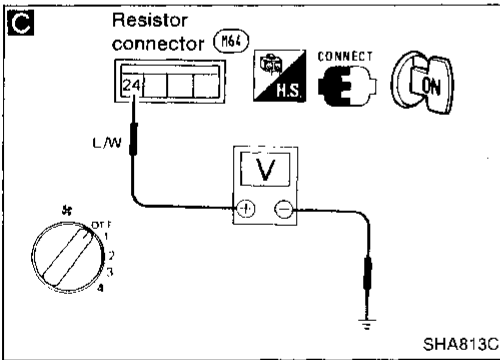
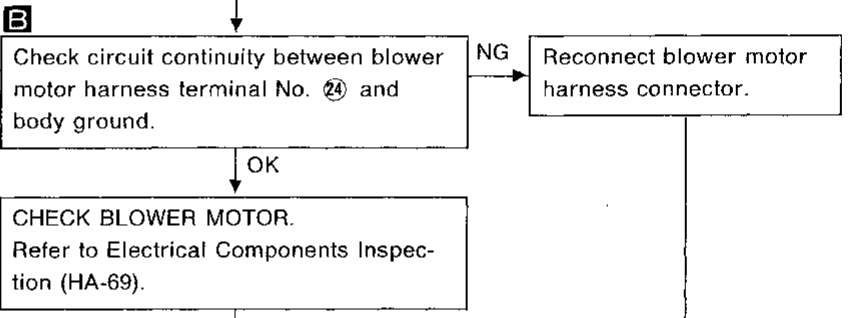
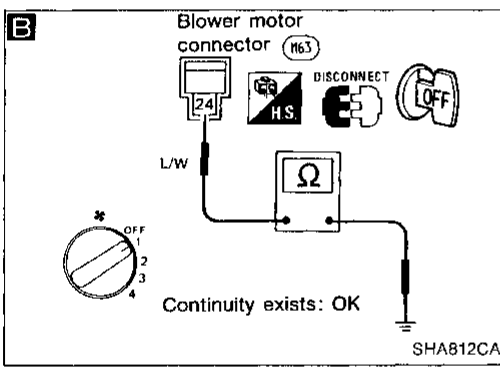
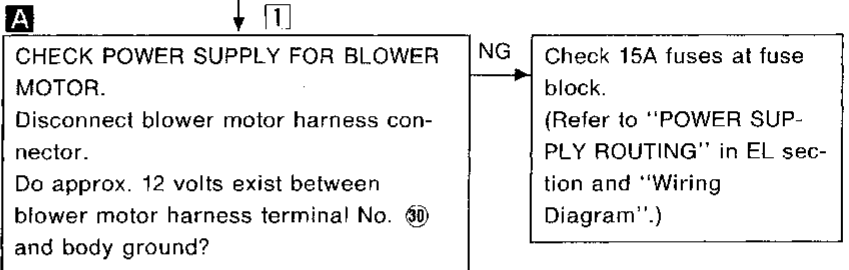
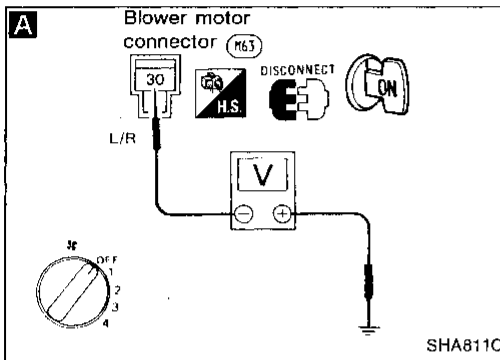
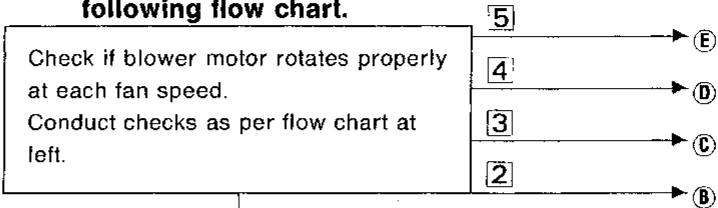

**Note:**  
If the result is NG after checking circuit continuity, repair harness or connector.

# TROUBLE DIAGNOSES

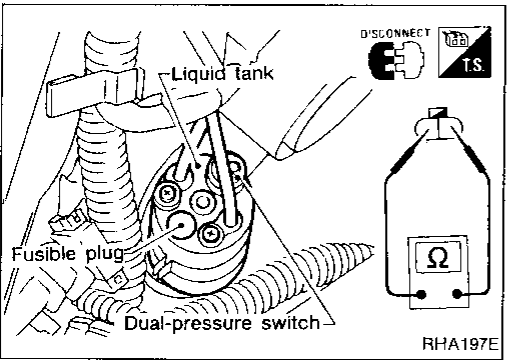
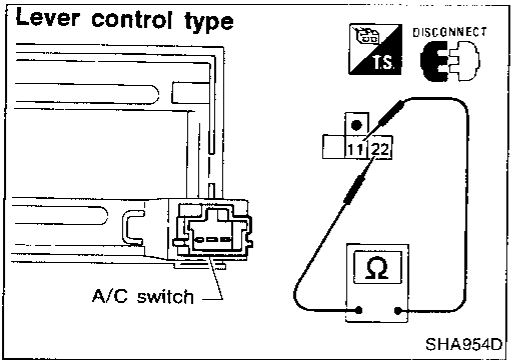
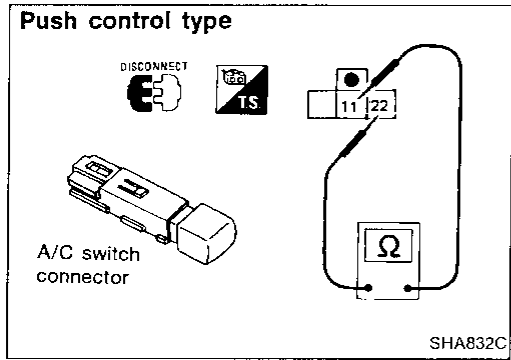

## Electrical Components Inspection

### A/C SWITCH

Check continuity between terminals at each switch position.

Switch condition	Terminal No.		Continuity
	⊕	⊖	
A/C			
ON			Yes
ON	②②	①①	
OFF			

### DUAL-PRESSURE SWITCH

High-pressure side line pressure kPa (kg/cm <sup>2</sup> , psi)	Operation	Continuity
Decreasing to 157 - 196 (1.6 - 2.0, 23 - 28) Increasing to 2,452 - 2,844 (25 - 29, 356 - 412)	Turn OFF	Does not exist
Increasing to 157 - 216 (1.6 - 2.2, 23 - 31) Decreasing to 1,765 - 2,354 (18 - 24, 256 - 341)	Turn ON	Exists

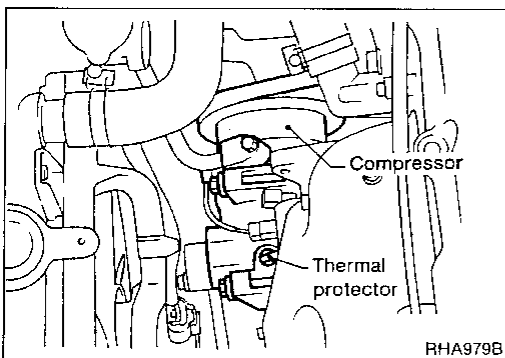

### THERMAL PROTECTOR

Temperature of compressor °C (°F)	Operation
Increasing to approx. 135 - 145 (275 - 293)	Turn OFF
Decreasing to approx. 120 - 130 (248 - 266)	Turn ON

CI  
VA  
EM  
LC  
EF & EC  
FE  
CL  
MT  
AT  
FA  
RA  
BR  
ST  
BF  
HA  
EL  
IDX

# ALPHABETICAL INDEX

## A

ABS (anti-lock brake system).....	BR-28
ABS actuator .....	BR-35
ABS circuit diagram.....	BR-33
ABS component parts and connector locations.....	BR-45
ABS control unit.....	BR-35
ABS hydraulic circuit.....	BR-32
ABS self-diagnosis.....	BR-44
ABS symptom chart.....	BR-42
ABS system components.....	BR-30
ABS trouble diagnoses.....	BR-38
ABS wheel sensors.....	BR-35
ABS wiring diagram.....	BR-34
A/C air flow.....	HA-8
A/C circuit diagram (manual A/C) .....	HA-44
A/C component layout.....	HA-7
A/C compressor clutch removal and installation .....	HA-23
A/C compressor mounting.....	HA-19
A/C compressor precaution .....	HA-5
A/C control operation (manual A/C).....	HA-6
A/C diagnostic work flow (manual A/C).....	HA-26
A/C harness layout (manual A/C).....	HA-42
A/C HFC134a (R134a) system identification .....	HA-2
A/C HFC134a (R134a) system introduction.....	HA-2
A/C HFC134a (R134a) system precaution.....	HA-3
A/C HFC134a (R134a) system service procedure.....	HA-15
A/C HFC134a (R134a) system service tools.....	HA-11
A/C HFC134a system service equipment precaution .....	HA-13
A/C lubrication oil.....	HA-21
A/C operational check .....	HA-27
A/C performance chart.....	HA-29
A/C performance test diagnoses .....	HA-30
A/C push control .....	HA-73
A/C relay .....	HA-68
A/C service data specification .....	HA-78
A/C switch .....	HA-67
A/C symptom chart (manual A/C).....	HA-36
A/C trouble diagnoses (manual A/C).....	HA-35
A/C wiring diagram (manual A/C) .....	HA-48
Acceleration cut control (SR engine) ..	EF&EC-26
Accelerator control system.....	FE-2
Accelerator wire adjustment.....	FE-2
Activated carbon canister (GA engine).....	EF&EC-206
Activated carbon canister (SR engine).....	EF&EC-18

Activated carbon canister inspection (GA engine).....	EF&EC-381
Air bag .....	BF-86
Air bag caution labels.....	BF-88
Air bag precautions .....	GI-2
Air bag removal and installation.....	BF-92
Air bag scrapping.....	BF-96
Air bag system trouble diagnoses .....	BF-98
Air bleeding for brake system .....	BR-3
Air cleaner filter replacement (GA engine).....	MA-19
Air cleaner filter replacement (SR engine) .....	MA-12
Air control cable adjustment.....	HA-70
Air Spoiler (Rear).....	BF-81
Alternator .....	EL-22
Angular tightening application.....	EM-2
Anti-freeze coolant.....	MA-8
ASCD (automatic speed control device).....	EL-70
AT control unit (RE4F03V).....	AT-94
AT fluid temperature sensor (RE4F03V).....	AT-98
AT mode switch (RE4F03V).....	AT-99
Audio .....	EL-67
Automatic transaxle number .....	GI-18
Automatic transmission fluid .....	MA-8
Automatic transmission fluid replacement.....	MA-23
Auxiliary air control (AAC) (GA engine).....	EF&EC-205
Auxiliary air control (AAC) (SR engine).....	EF&EC-16

## B

Back-up lamp.....	EL-32
Back-up lamp switch (MT).....	MT-6
Ball joint front axle.....	FA-24
Battery.....	EL-11
Baulk ring (MT) (RS5F31A).....	MT-11
Baulk ring (MT) (RS5F32V).....	MT-31
Belt inspection (drive belt) (GA engine).....	MA-16
Belt inspection (drive belt) (SR engine) .....	MA-9
Blower motor.....	HA-69
Blower resistor.....	HA-69
Body alignment.....	BF-82
Boring/horning cylinder block (GA engine).....	EM-102
Brake booster.....	BR-12
Brake control valve (Proportioning Valve).....	BR-7
Brake fluid .....	MA-8
Brake fluid change.....	BR-3
Brake fluid level .....	MA-24

## Lubrication Circuit

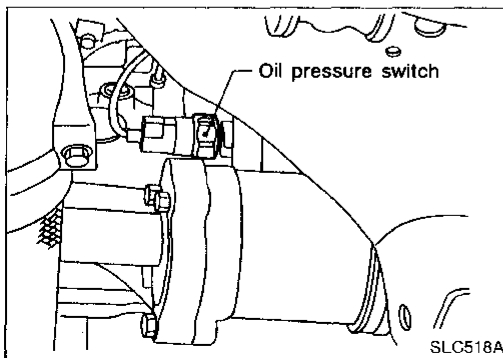
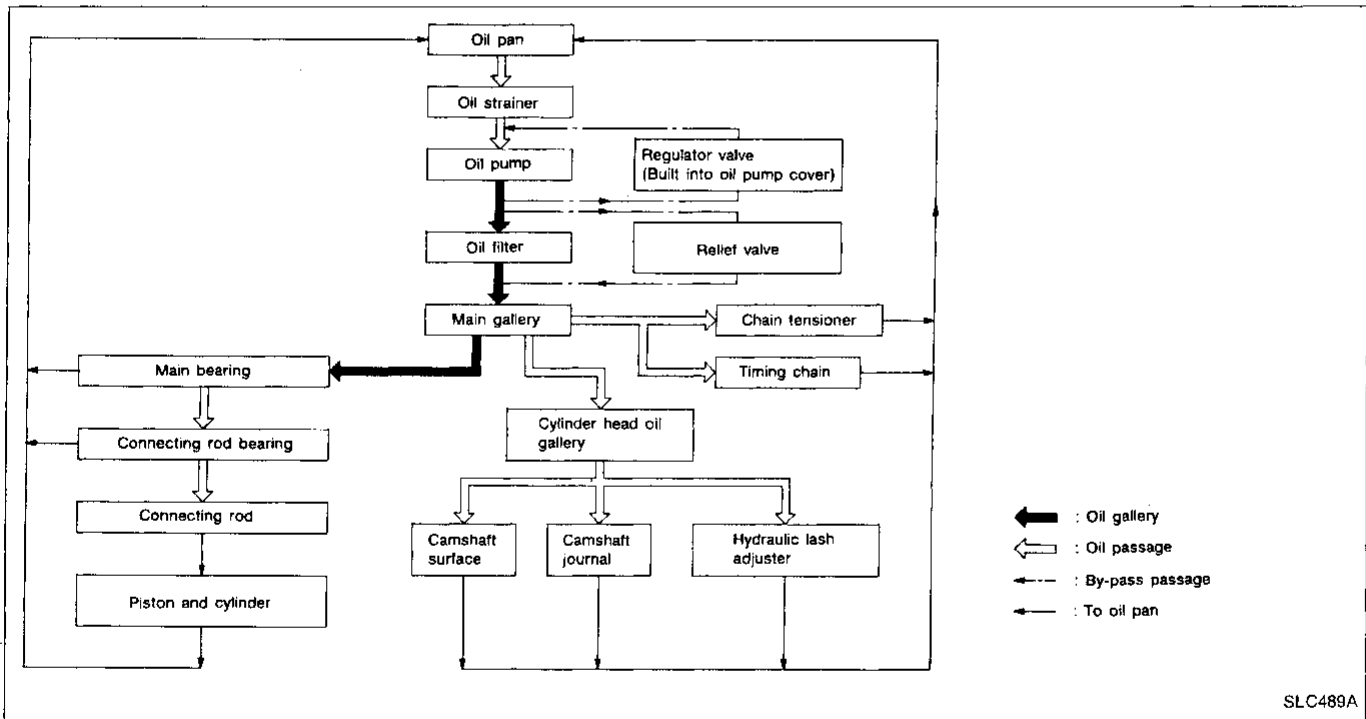
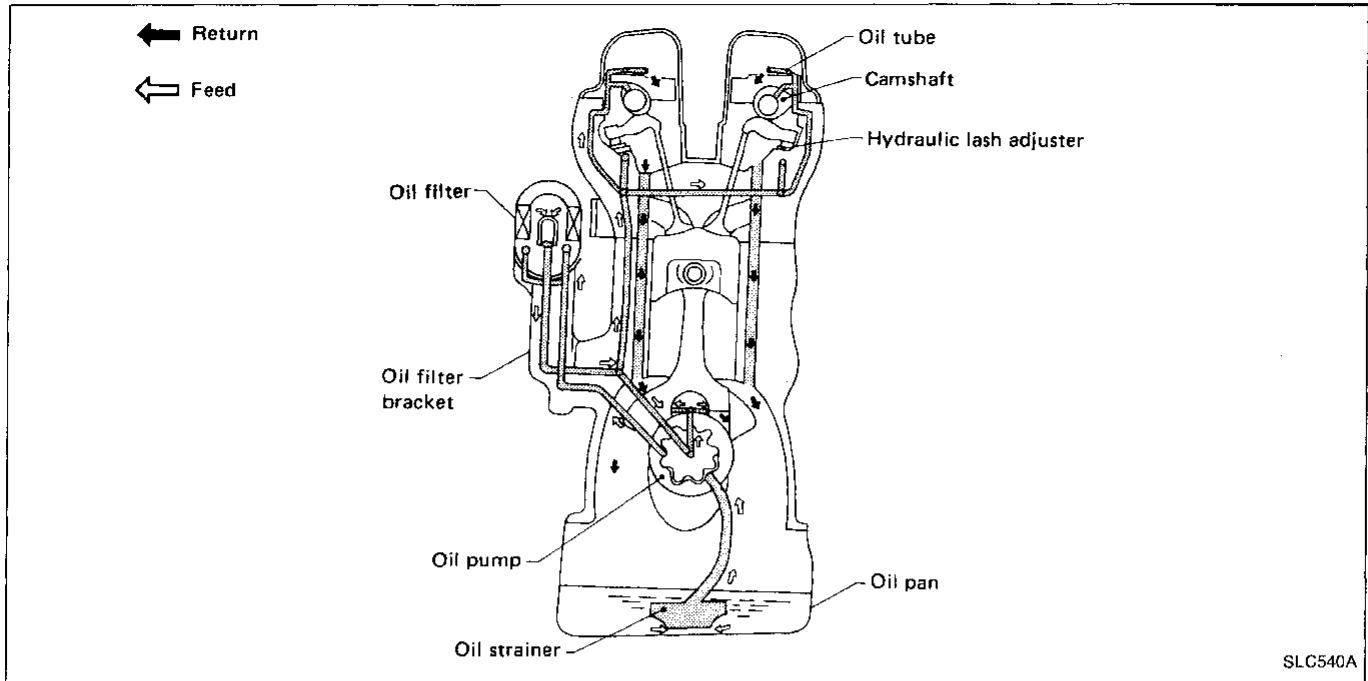

## Oil Pressure Check

### WARNING:

- Be careful not to burn yourself, as the engine and oil may be hot.
  - Oil pressure check should be done in "Neutral" position.
1. Check oil level.
  2. Remove oil pressure switch.

**Water Pump (Cont'd)**

**CAUTION:**

- When removing water pump assembly, be careful not to get coolant on timing chain.
- Water pump cannot be disassembled and should be replaced as a unit.
- After installing water pump, connect hose and clamp securely, then check for leaks using radiator cap tester.

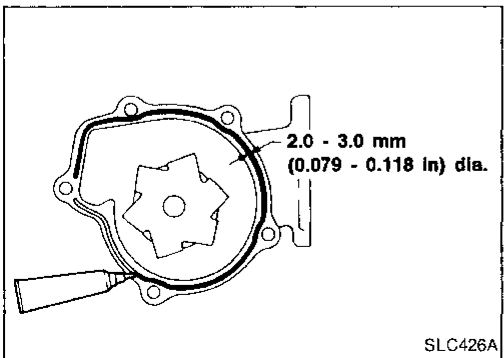
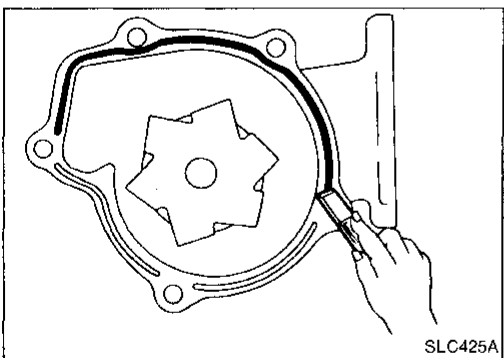
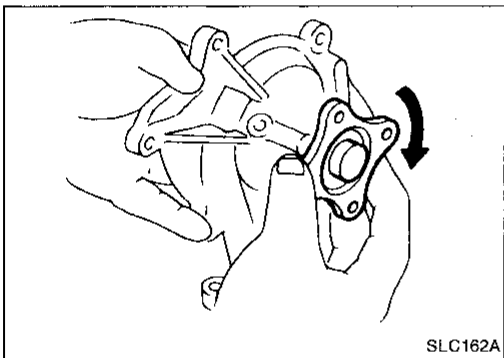
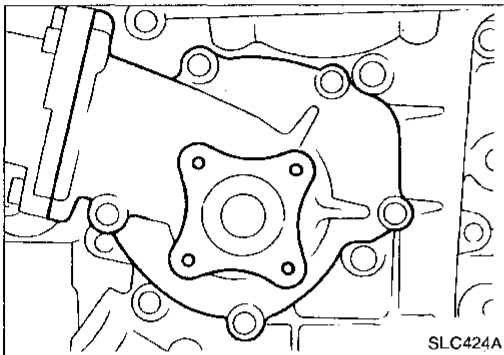

**REMOVAL**

1. Drain coolant from radiator and cylinder block.
2. Remove drive belts for compressor, power steering pump and alternator.
3. Remove water pump pulley.
4. Remove water pump.

**INSPECTION**

1. Check for badly rusted or corroded body assembly and vane.
2. Check for rough operation due to excessive end play.

**INSTALLATION**

- Before installing water pump, remove liquid gasket from mating surface of water pump using a scraper.

**Be sure liquid gasket in grooves is also removed.**

- Remove liquid gasket from mating surface of front cover.
- Remove all traces of liquid gasket using white gasoline.

- Apply liquid gasket to mating surface of pump housing as shown.

GI

MA

EM

LC

FF &  
EC

FE

CL

MT

AT

FA

RA

BR

ST

BF

HA

EL

IDX

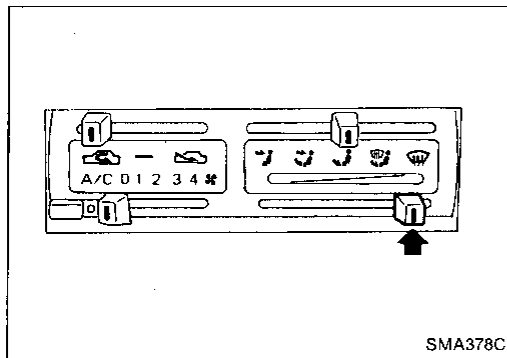

### Changing Engine Coolant

**WARNING:**

To avoid being scalded, never change the coolant when the engine is hot.

1. Move heater "TEMP" control lever all the way to "HOT".

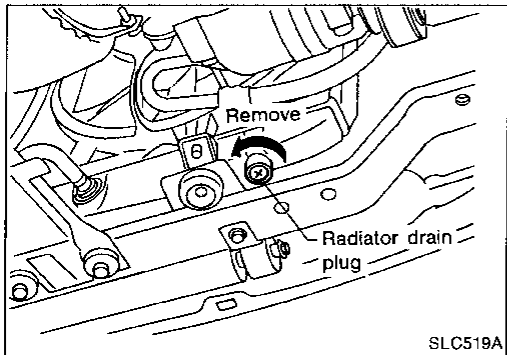

2. Remove radiator drain plug and radiator filler cap.
3. Remove reservoir tank, drain coolant, then clean reservoir tank. Install it temporarily.

- Be careful not to allow coolant to contact drive belts.

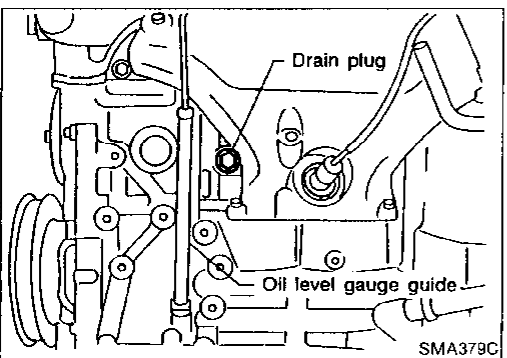
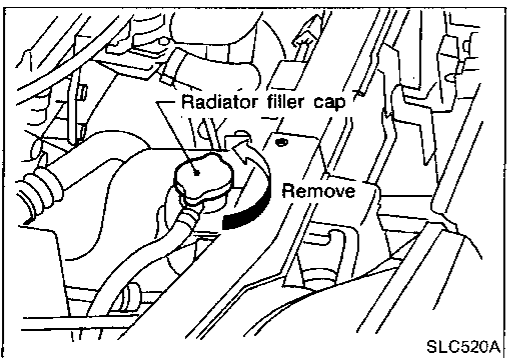

4. Remove cylinder block drain plug and air relief plug.
5. Install radiator drain plug and tighten cylinder block drain plug securely.
6. Fill radiator and reservoir tank with water. Air relief plug is reinstalled once coolant spills from the air relief hole during refill. Then fill radiator and reservoir tank with water.

**Air relief plug:**

: 10 N·m (1.0 kg-m, 7 ft-lb)

7. Reinstall radiator cap.
8. Warm up engine until cooling fan operates, then race engine 2 or 3 times under no-load.

- Make sure that air conditioner switch is "OFF".

9. Stop engine and wait until it cools down.
10. Repeat step 2 through step 9 until clear water begins to drain from radiator.
11. Drain water.

- Apply sealant to the thread of drain plug.

: 8 - 12 N·m (0.8 - 1.2 kg-m, 5.8 - 8.7 ft-lb)

12. Reinstall reservoir tank.

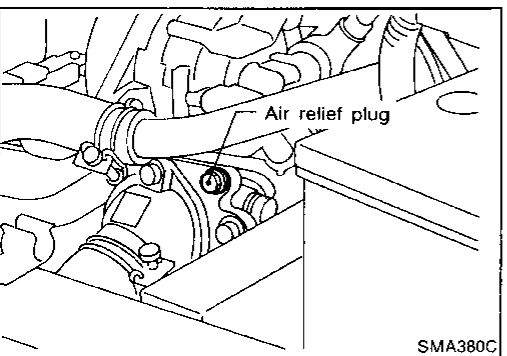

# CHASSIS AND BODY MAINTENANCE

## Checking A/T Fluid (Cont'd)

- 1) Park vehicle on level surface and set parking brake.
- 2) Start engine and then move selector lever through each gear range, ending in "P".
- 3) Check fluid level with engine idling.
- 4) Remove dipstick and wipe it clean with lint-free paper.
- 5) Re-insert dipstick into charging pipe as far as it will go.
- 6) Remove dipstick and note reading. If level is at low side of either range, add fluid to the charging pipe.

**Do not overfill.**

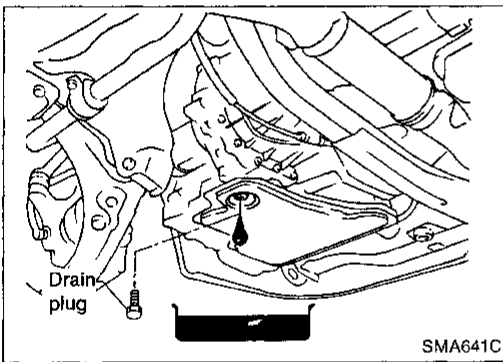
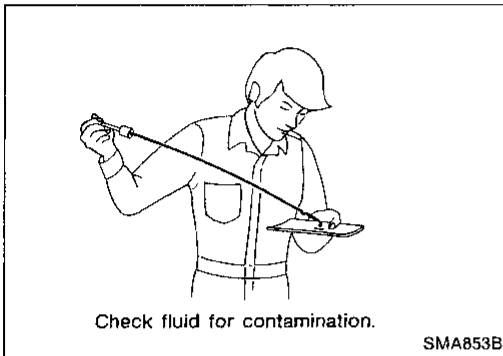

2. Check fluid for contamination. If fluid is very dark or smells burned, or contains frictional material (clutches, band, etc.), check operation of A/T. Refer to section AT for checking operation of A/T.

## Changing A/T Fluid

1. Warm up A/T fluid.
2. Stop engine.
3. Drain A/T fluid from drain plug and refill with new A/T fluid. Always refill same volume with drained fluid.

**Oil grade:**

**Genuine Nissan ATF or equivalent type DEXRON™ II-E**

**Oil capacity (With torque converter):**

**7.0 liters (7-3/8 US qt, 6-1/8 Imp qt)**

**Drain plug:**

**⌚: 29 - 39 N·m (3.0 - 4.0 kg·m, 22 - 29 ft·lb)**

4. Run engine at idle speed for five minutes.
5. Check fluid level and condition. Refer to "Checking A/T Fluid". If fluid is still dirty, repeat step 2. through 5.

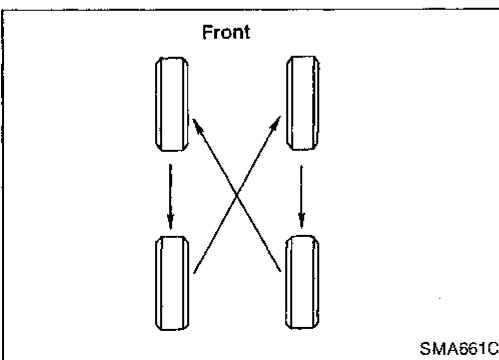

## Balancing Wheels

- Adjust wheel balance using road wheel center.  
**Wheel balance (Maximum allowable unbalance):**  
Refer to SDS.

## Tire Rotation

**Do not include the T-type spare tire when rotating the tires.**

**Wheel nuts:**

**⌚: 98 - 118 N·m (10.0 - 12.0 kg·m, 72 - 87 ft·lb)**

# REMOVAL AND INSTALLATION

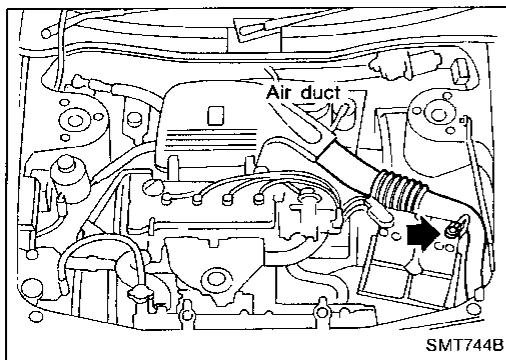

## Removal

1. Remove battery negative terminal.
2. Remove air duct.

GI

MA

EM

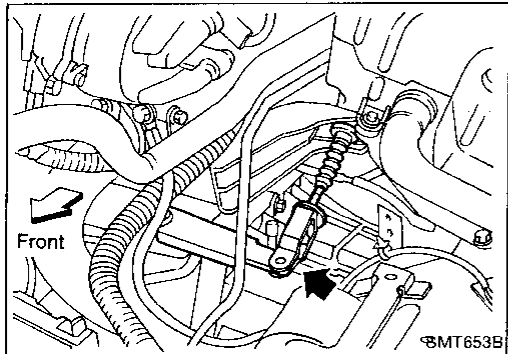

3. Disconnect clutch control cable.
4. Disconnect speedometer cable from transaxle.
5. Disconnect back-up lamp switch, neutral switch and ground harness connectors.
6. Remove starter motor from transaxle.

LC

EF &  
EC

FE

CL

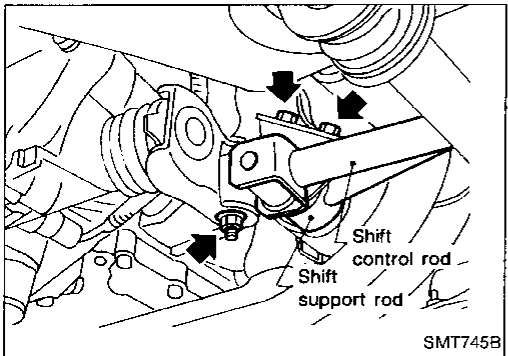

7. Remove shift control rod and support rod from transaxle.
8. Drain gear oil from transaxle.
9. Remove exhaust front tube.
10. Draw out drive shafts from transaxle — Refer to section FA.

MT

AT

FA

RA

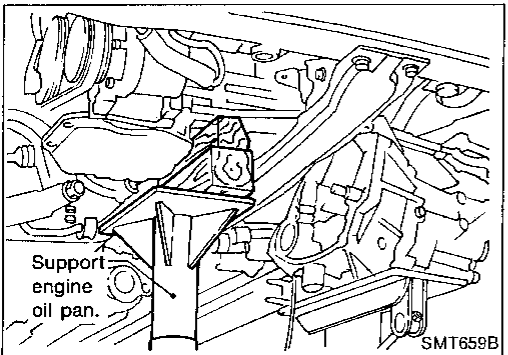

11. Support engine by placing a jack under oil pan.

### CAUTION:

**Do not place jack under oil pan drain plug.**

12. Remove rear and LH mounts.
13. Remove bolts securing transaxle.
14. Lower transaxle while supporting it with a jack.

BR

ST

BF

HA

EL

IDX

Mainshaft and Gears (Cont'd)

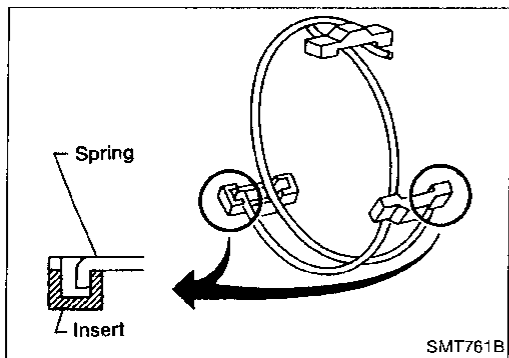

- Be careful not to hook front and rear ends of spread spring to the same insert.

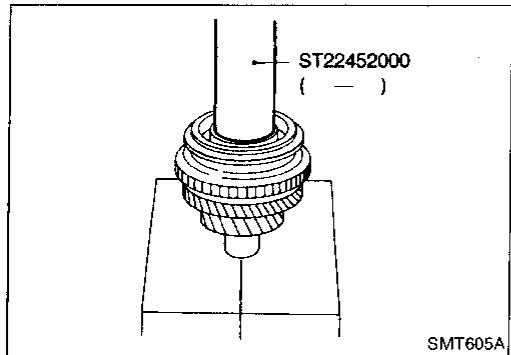

2. Install 1st gear needle bearing and 1st main gear.
3. Press on 1st & 2nd synchronizer.

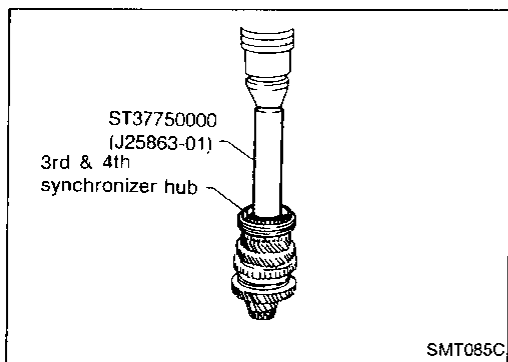

4. Install steel ball, 2nd main gear, 2nd & 3rd bushing, 3rd main gear and 3rd & 4th synchronizer with Tool.
- Apply multi-purpose grease to steel ball before installing it.
  - 2nd & 3rd bushing has a groove in which steel ball fits.

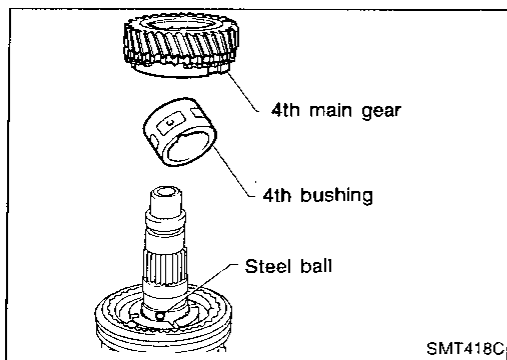

5. Install steel ball, 4th bushing and 4th main gear.
- Apply multi-purpose grease to steel ball before installing it.
  - 4th bushing has a groove in which steel ball fits.

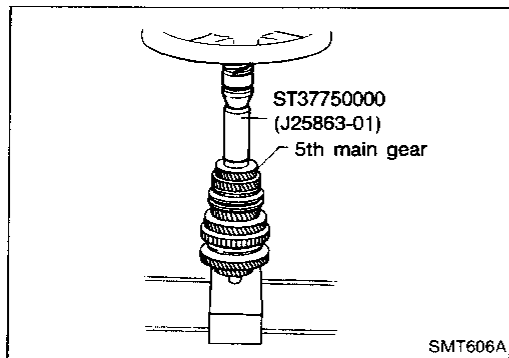

6. Press on 5th main gear.

CLICK HERE TO **DOWNLOAD** THE COMPLETE MANUAL

- Thank you very much for reading the preview of the manual.
- You can download the complete manual from: [www.heydownloads.com](http://www.heydownloads.com) by clicking the link below



- Please note: If there is no response to CLICKING the link, please download this PDF first and then click on it.

CLICK HERE TO **DOWNLOAD** THE COMPLETE MANUAL