

YAMAHA

XTZ660 ('91)

3YF-ME1

SERVICE MANUAL

CLICK HERE TO **DOWNLOAD** THE COMPLETE MANUAL

- Thank you very much for reading the preview of the manual.
- You can download the complete manual from: www.heydownloads.com by clicking the link below



- Please note: If there is no response to CLICKING the link, please download this PDF first and then click on it.

CLICK HERE TO **DOWNLOAD** THE COMPLETE MANUAL

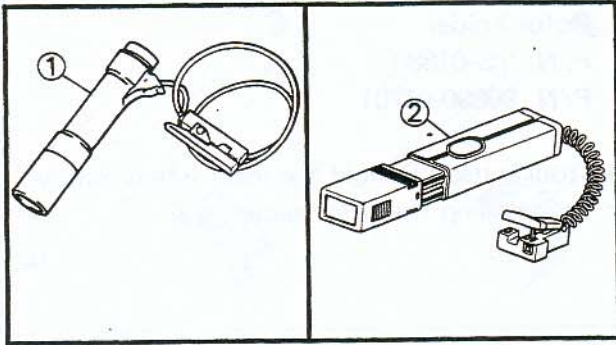

3. Inductive timing light
 P/N. YM-33277-A-①
 P/N. 90890-03141-②

This tool is necessary for checking ignition timing.

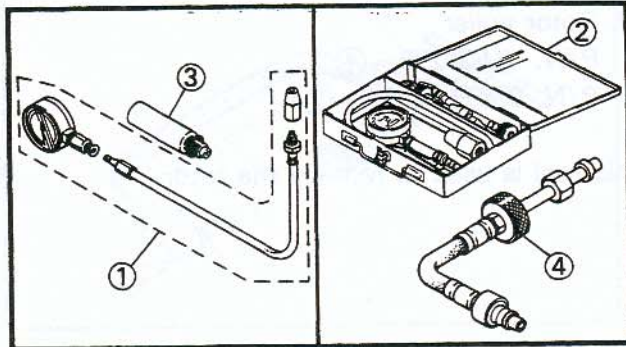

4. Compression gauge
 P/N. YU-33223-①
 P/N. 90890-03081-②
 Adapter (M12)
 P/N. YU-33223-3-③
 P/N. 90890-04082-④

These gauges are used to measure the engine compression.

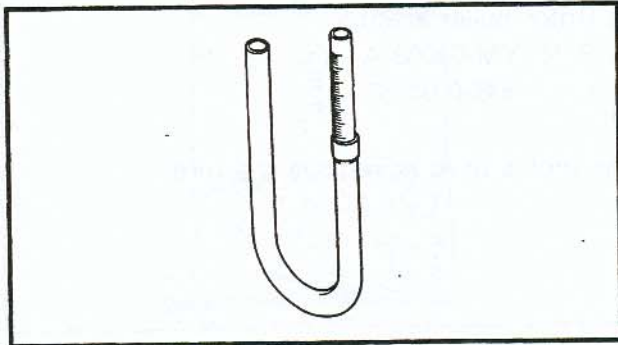

5. Fuel level gauge
 P/N. YM-01312-A
 P/N. 90890-01312

This gauge is used to measure the fuel level in the float chamber.

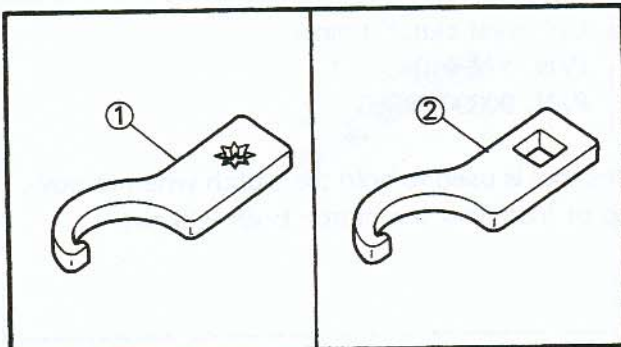

6. Steering nut wrench
 P/N. YM-38520-①
 P/N. 90890-01443-②

This tool is used to adjust the spring preload of rear shock absorber.

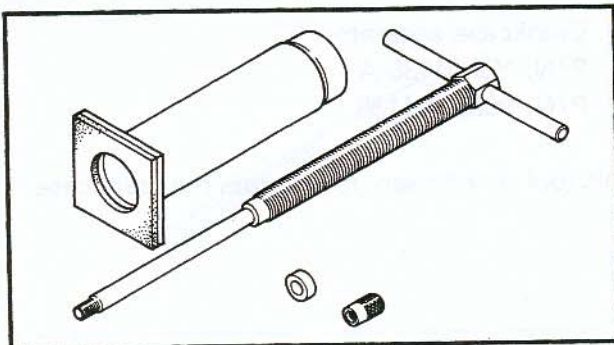

FOR ENGINE SERVICE

1. Piston pin puller
 P/N. YU-01304
 P/N. 90890-01304

This tool is used to remove the piston pin.



MAINTENANCE SPECIFICATIONS

ENGINE

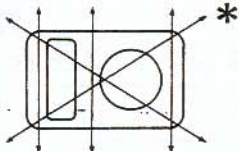
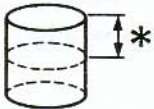
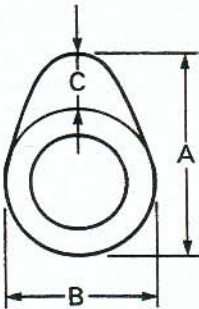
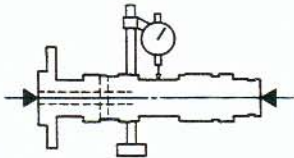
| Model | XTZ660 |
|---|---|
| <p>Cylinder Head: Warp Limit*</p>  | <p>0.03 mm (0.0012 in) * Lines indicate straightedge measurement.</p> |
| <p>Cylinder: Bore Size/Measuring Point*</p>  <p><Wear limit></p> | <p>100.005 ~ 100.045 mm (3.9372 ~ 3.9388 in) 50 mm (1.97 in) 100.1 mm (3.941 in)</p> |
| <p>Camshaft: Drive Method Camshaft Outside Diameter Shaft-to-cap Clearance Cam Dimensions: Intake</p>  <p>Exhaust</p> <p>Camshaft Runout Limit</p>  | <p>Chain drive (Left) 22.967 ~ 22.980 mm (0.9042 ~ 0.9047 in) 0.020 ~ 0.054 mm (0.0008 ~ 0.0021 in) "A" 35.69 ~ 35.79 mm (1.4051 ~ 1.4091 in) < Limit > 35.54 mm (1.3992 in) "B" 30.06 ~ 30.16 mm (1.1835 ~ 1.1874 in) < Limit > 29.91 mm (1.1776 in) "C" 5.74 mm (0.2260 in) Exhaust "A" 36.50 ~ 36.60 mm (1.4370 ~ 1.4409 in) < Limit > 36.35 mm (1.4311 in) "B" 30.11 ~ 30.21 mm (1.1854 ~ 1.1894 in) < Limit > 29.96 mm (1.1795 in) "C" 6.55 mm (0.2579 in) 0.03 mm (0.0012 in)</p> |
| <p>Timing Chain: Chain Type/No. of Links Chain Adjustment Method</p> | <p>75 RH 2015/126 Links Automatic</p> |
| <p>Rocker Arm/Rocker Arm Shaft: Rocker Arm Inside Diameter Shaft Outside Diameter Arm-to-shaft Clearance</p> | <p>12.000 ~ 12.018 mm (0.472 ~ 0.473 in) 11.976 ~ 11.991 mm (0.471 ~ 0.472 in) 0.009 ~ 0.042 mm (0.0004 ~ 0.0020 in)</p> |

MAINTENANCE SPECIFICATIONS

SPEC



CHASSIS

| Model | XTZ660 |
|--|---|
| Steering System: Steering Bearing Type | Taper Roller Bearing |
| Front Suspension: Front Fork Travel Front Spring Free Length < Limit > Spring Rate: K1 Stroke K1 Optional Spring Oil Capacity Oil Level Oil Grade Enclosed Air Pressure: Standard | 220 mm (8.66 in) 407 mm (16.02 in) < 402.9 mm (15.86 in) > 4.25 N/mm (0.425 kg/mm, 23.80 lb/in) 0.0 ~ 220 mm (0.0 ~ 8.66 in) No 669 cm ³ (23.5 Imp oz, 22.6 US oz) 94 mm (3.70 in) From top of inner tube fully compressed without spring. Fork oil 10W or equivalent Zero |
| Rear Suspension: Shock Absorber Travel Spring Free Length Fitting Length Spring Rate K1 Stroke K1 Optional Spring Enclosed Gas Pressure: Standard | 66 mm (2.60 in) 222 mm (8.74 in) 212 mm (8.35 in) 125 N/mm (12.5 kg/mm, 700 lb/in) 0.0 ~ 83.0 mm (0.0 ~ 3.3 in) No 1.500 kPa (15 kg/cm ² , 213 psi) |
| Swingarm: Free Play Limit Side Clearance | 1.0 mm (0.039 in) at swingarm end Move swingarm end side to side 0.4 ~ 0.7 mm (0.016 ~ 0.028 in) at swingarm pivot |
| Front Wheel: Type Rim Size Rim Material Rim Runout Limit Vertical Lateral | Spoke wheel 21 × 1.85 Aluminum 2 mm (0.08 in) 2 mm (0.08 in) |
| Rear Wheel: Type Rim Size Rim Material Rim Runout Limit Vertical Lateral | Spoke wheel 17 × 2.75 Aluminum 2 mm (0.08 in) 2 mm (0.08 in) |
| Drive Chain: Type/Manufacturer No. of Links Chain Free Play | 520V6/DAIDO, 520SM0Z9/RK 110 20 ~ 45 mm (0.79 ~ 1.77 in) |



LUBRICATION DIAGRAM

- ① Oil tank
- ② Oil pump
- ③ Oil strainer (engine)

- A Feed
- B Scavenge

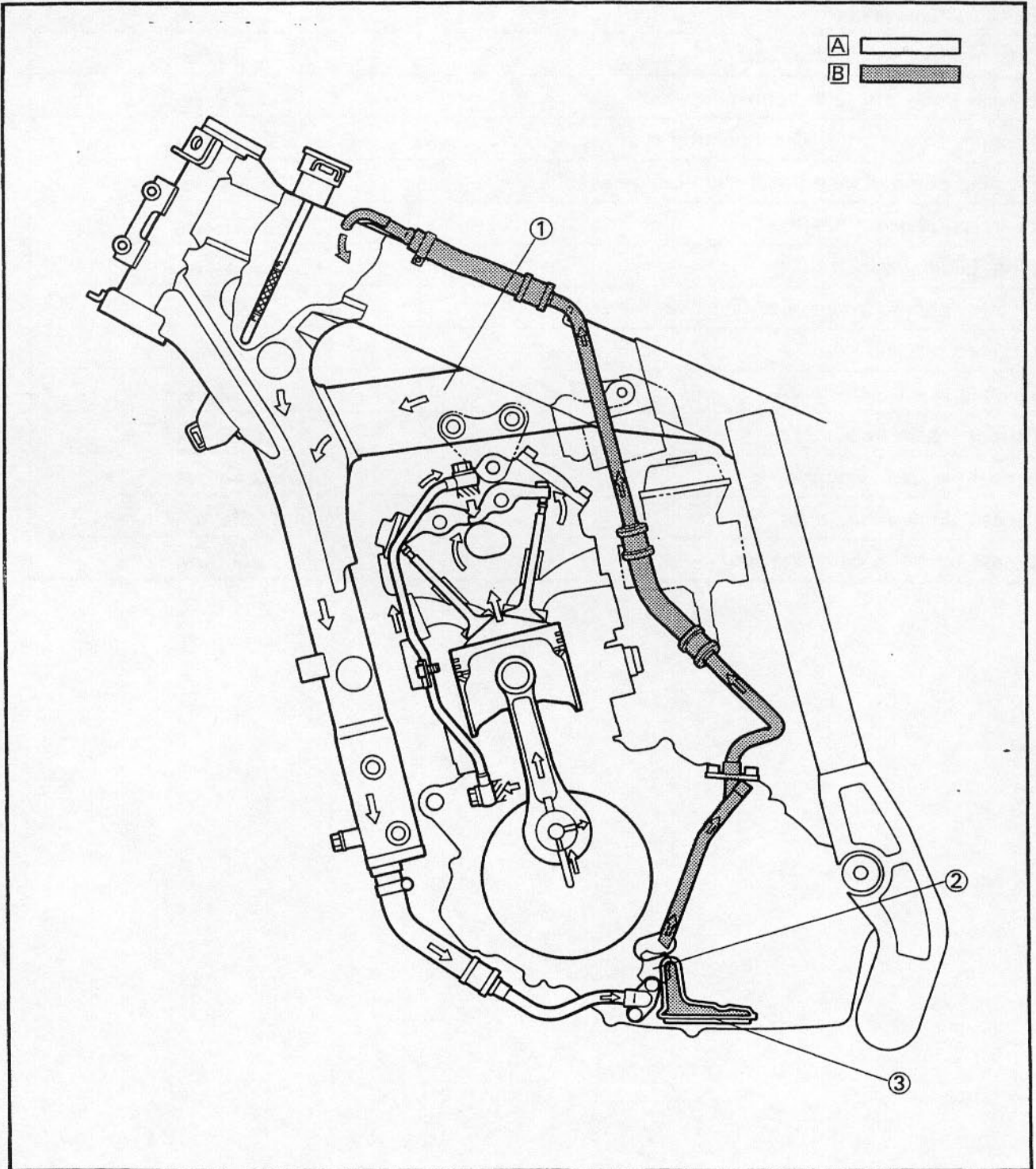

| | |
|---------------------------------------|-------------|
| TIRE INSPECTION | D-11 |
| WHEEL INSPECTION | D-13 |
| SPOKES INSPECTION AND TIGHTENING..... | D-13 |
| CABLE INSPECTION AND LUBRICATION..... | D-13 |
| LEVER AND PEDAL LUBRICATION | D-13 |
| SIDESTAND LUBRICATION | D-13 |
| REAR SUSPENSION LUBRICATION | D-14 |
| ELECTRICAL | D-14 |
| BATTERY INSPECTION | D-14 |
| FUSE INSPECTION | E-1 |
| HEADLIGHT BEAM ADJUSTMENT | E-2 |
| HEADLIGHT BULB REPLACEMENT | E-2 |

VALVE CLEARANCE ADJUSTMENT

INSP
ADJ

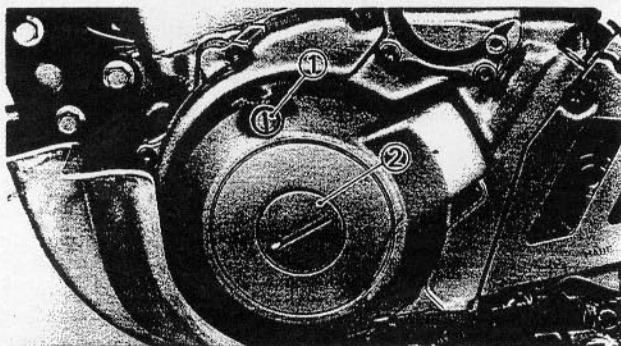

6. Remove:
- Plug ①
 - Plug ②

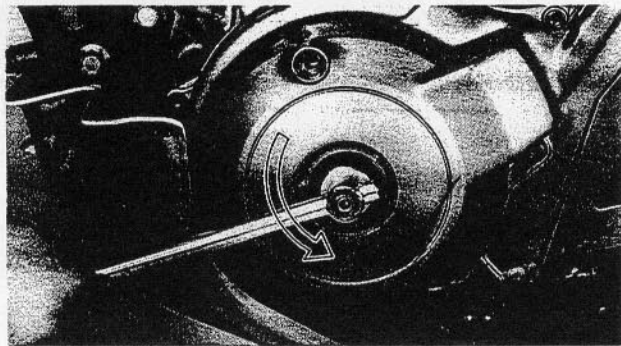

7. Turn the crankshaft counterclockwise with a wrench.

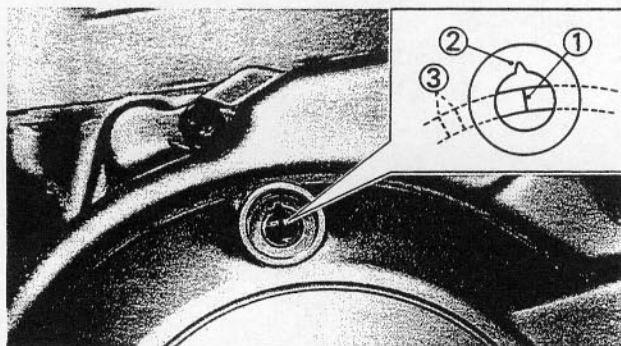

8. Align:
- "T" mark ①
- With stationary pointer ②.

NOTE: _____
Make sure the piston is at the T.D.C. on compression stroke.

③ Ignition timing mark

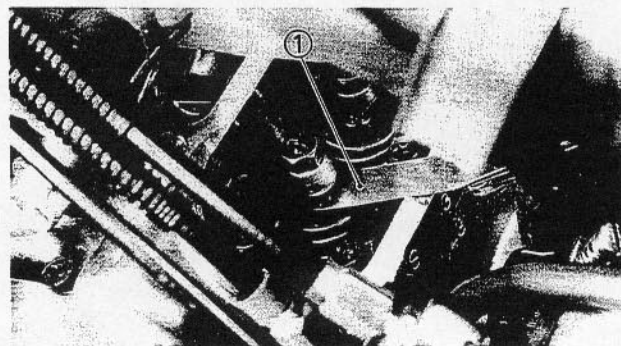

9. Check:
- Valve clearance
- Measure the valve clearance by using a feeler gauge ①.
Out of specification → Adjust.



Valve clearance (cold):

Intake:

0.10 ~ 0.15 mm (0.004 ~ 0.006 in)

Exhaust:

0.15 ~ 0.20 mm (0.006 ~ 0.008 in)

ENGINE OIL LEVEL INSPECTION

INSP
ADJ



Bolts (fuel tank, cowling and fuel tank, side cover):

7 Nm (0.7 m•kg, 5.1 ft•lb)

Bolt (seat):

10 Nm (1.0 m•kg, 7.2 ft•lb)

ENGINE OIL LEVEL INSPECTION

CAUTION:

Do not add any chemical additives. Engine oil also lubricates the clutch and additives could cause clutch slippage.

WARNING

Never remove the oil tank cap just after high speed operation. The heated oil could spurt out, causing danger. Wait until the oil cools down to approximately 70°C (158°F).

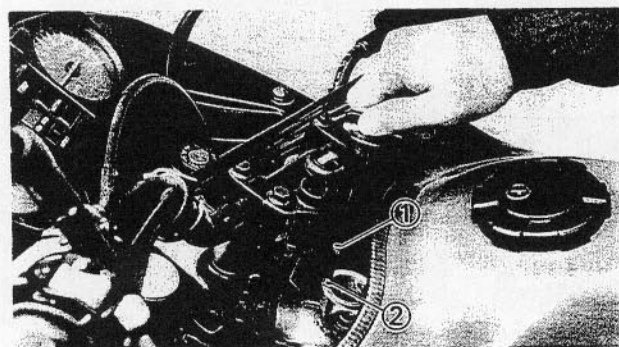
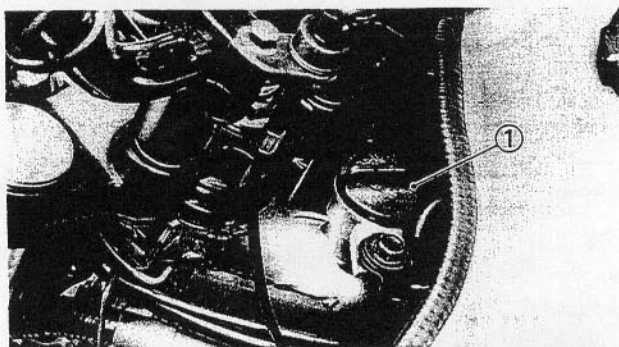

1. Place the motorcycle on a level place.

2. Remove:

- Oil tank cap ①

3. Inspect:

- Oil level

Oil level should be between the maximum level ① and minimum level ②.

NOTE:

- Be sure the motorcycle is positioned straight up when checking the oil level.
- When inspecting the oil level, do not screw the oil level gauge into the oil tank. Insert the gauge lightly.

Oil level is incorrect → Add the oil up to the minimum level.



Recommended oil:

SAE 20W40 type SE motor oil or
SAE 10W30 type SE motor oil

EXHAUST SYSTEM INSPECTION/ COOLANT LEVEL INSPECTION

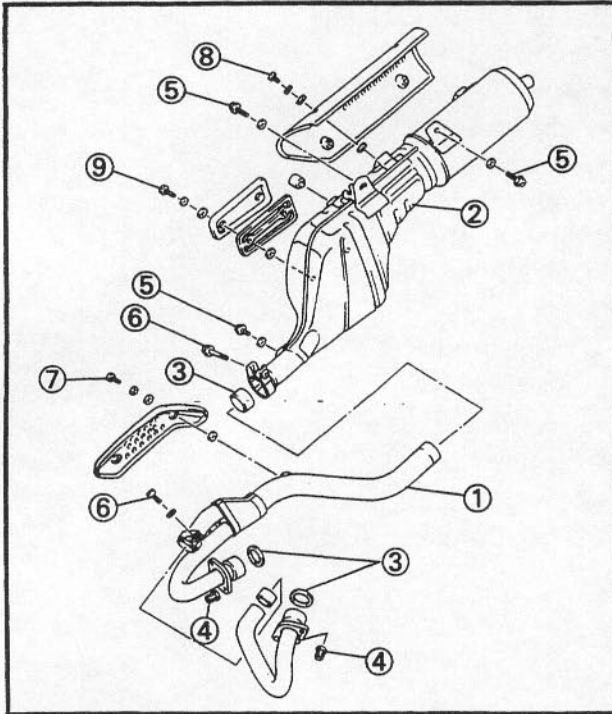

EXHAUST SYSTEM INSPECTION

1. Inspect:

- Exhaust pipe ①
- Muffler ②
- Crack/Damage → Replace.
- Gasket ③
- Exhaust gas leaks → Replace.



Nut ④ (exhaust pipe):

10 Nm (1.0 m•kg, 7.2 ft•lb)

Bolt ⑤ (muffler):

40 Nm (4.0 m•kg, 29 ft•lb)

Bolt ⑥ (clamp):

20 Nm (2.0 m•kg, 14 ft•lb)

Screw ⑦ (protector):

7 Nm (0.7 m•kg, 5.1 ft•lb)

Use LOCTITE®.

Screw ⑧ (protector):

7 Nm (0.7 m•kg, 5.1 ft•lb)

Use LOCTITE®.

Screw ⑨ (protector):

7 Nm (0.7 m•kg, 5.1 ft•lb)

Use LOCTITE®.

YB2AD000

COOLANT LEVEL INSPECTION

1. Place the motorcycle on a level place.

NOTE:

Position the motorcycle straight up when inspecting the coolant level.

2. Remove:

- Air scoop (right)

3. Inspect:

- Coolant level

Coolant level should be between maximum ① and minimum ② marks.

Coolant level low → Add soft water (tap water) to proper level.

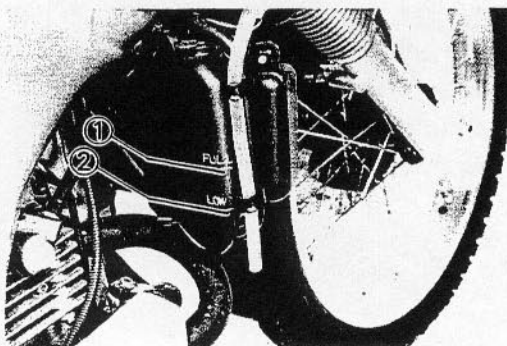



BRAKE LIGHT SWITCH ADJUSTMENT

NOTE:

The brake light switch is operated by movement of the brake pedal.

Proper adjustment is achieved when the brake light comes on just before the brake begins to take effect.

1. Check:

- Brake light operating timing
Incorrect → Adjust.

2. Adjust:

- Brake light operating timing

Adjustment steps:

Hold the switch body ① with your hand so that it does not rotate and turn the adjusting nut ②.

BRAKE HOSE INSPECTION

1. Inspect:

- Brake hose
Crack/Damage → Replace.
Refer to the "FRONT AND REAR BRAKE" section in the CHAPTER 7.

- A** Front
- B** Rear

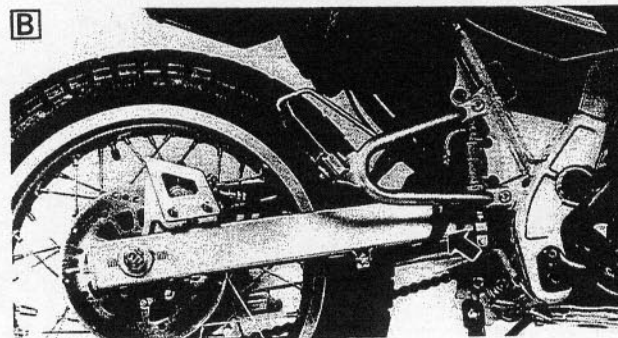
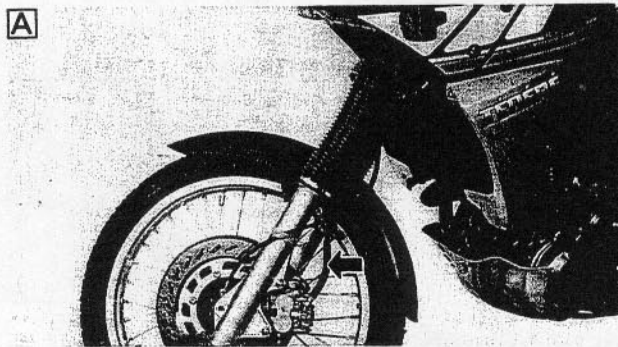
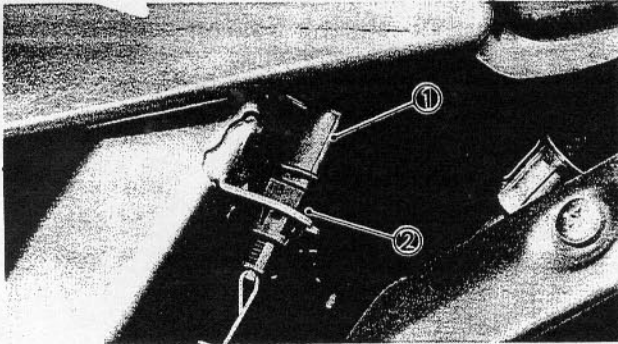

TIRE INSPECTION

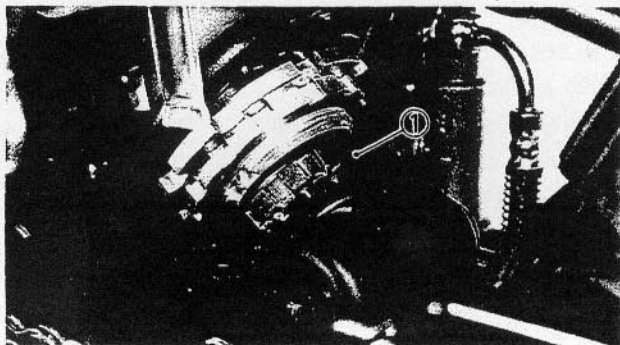

Adjustment steps:

Damping

- Adjust the damping with the damping adjuster ①.

| | Hard | | | S.T.D. | Soft |
|-------------------|------|---|---|--------|------|
| Adjuster position | 5 | 4 | 3 | 2 | 1 |

CAUTION:

Never attempt to turn the adjuster beyond the maximum or minimum setting.

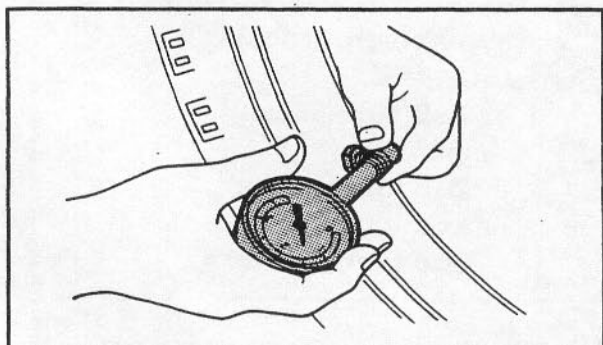

YB2A3014

TIRE INSPECTION

1. Measure:

- Tire pressure
- Out of specification → Adjust.

⚠ WARNING

- Tire inflation pressure should be checked and adjusted when the temperature of the tire equals the ambient air temperature. Tire inflation pressure must be adjusted according to total weight of cargo, rider, passenger, and accessories (fairing, saddlebags, etc. if approved for this model), and vehicle speed.
- Proper loading of your motorcycle is important for the handling, braking, and other performance and safety characteristics of your motorcycle. Do not carry loosely packed items that can shift. Securely pack your heaviest items close to the center of the motorcycle, and distribute the weight evenly from side to side. Properly adjust the suspension for your load, and check the condition and pressure of your tires. **NEVER OVERLOAD YOUR MOTORCYCLE.** Make sure the total weight of the cargo, rider, passenger, and accessories (fairing, saddlebags, etc. if approved for this model) does

BATTERY INSPECTION



Charging method using a variable-current (voltage) type charger

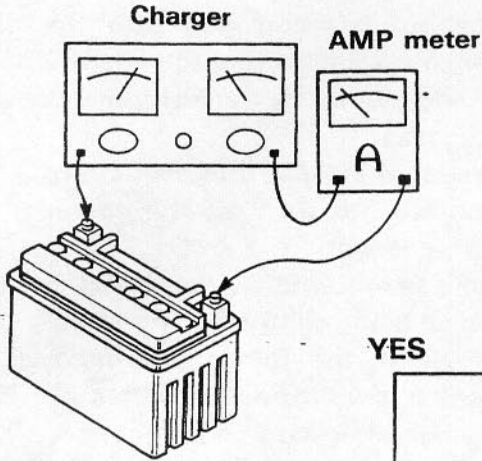

Measure the open-circuit voltage prior to charging.

NOTE: _____
Voltage should be measured 30 minutes after the machine is stopped.

Connect a charger and AMP meter to the battery and start charging.

NOTE: _____
Set the changing voltage at 16~17V. (If the setting is lower, charging will be insufficient. If too high, the battery will be over-charged.)

Make sure the current is higher than the standard charging current written on the battery.

YES

NO

By turning the charging voltage adjust dial, set the charging voltage at 20~25V.

Adjust the voltage so that current is at standard charging level.

YES

Monitor the amperage for 3~5 minutes to check if the standard charging current is reached.

NO

Set the timer according to the charging time suitable for the open-circuit voltage. Refer to the "Battery condition checking steps" section.

If current does not exceed standard charging current after 5 minutes, replace the battery.

In case that charging requires more than 5 hours, it is advisable to check the charging current after a lapse of 5 hours. If there is any change in the amperage, readjust the voltage to obtain the standard charging current.

Measure the battery open-circuit voltage after having left the battery unused for more than 30 minutes.
12.8V or more—Charging is complete.
12.7V or less—Recharging is required.
Under 12.0V—Replace the battery.

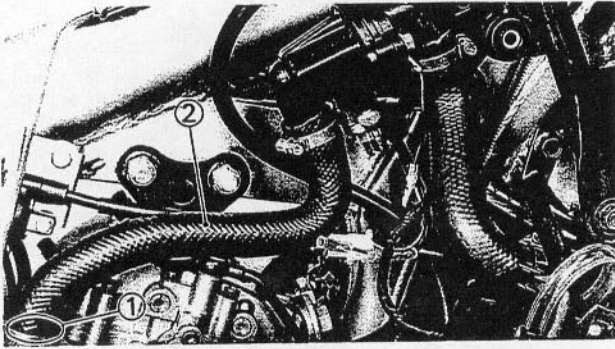

4. Loosen:
 - Screws ① (hose clamp)

5. Disconnect:
 - Radiator hose ②

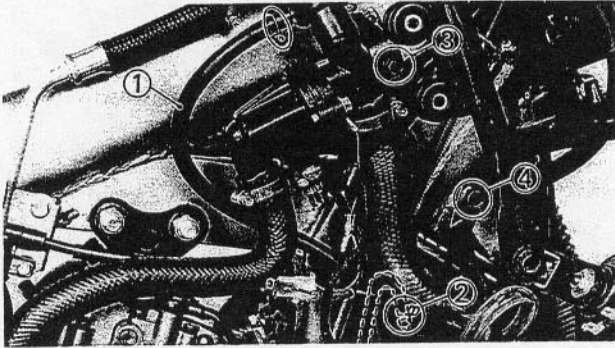

6. Disconnect:
 - Recovery tank hose ①
 - Breather hose ② (recovery tank)

7. Remove:
 - Bolt ③ (conduction)
 - Bolt ④ (radiator stay)

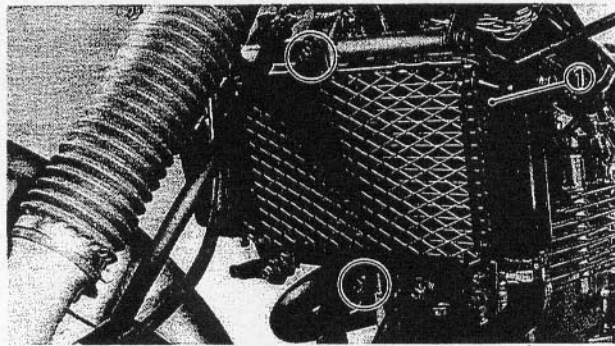

8. Remove:
 - Radiator ①

YB241005

EXHAUST PIPE AND MUFFLER

1. Loosen:
 - Bolt ① (clamp)
 - Bolt ② (clamp)

2. Remove:
 - Muffler ①

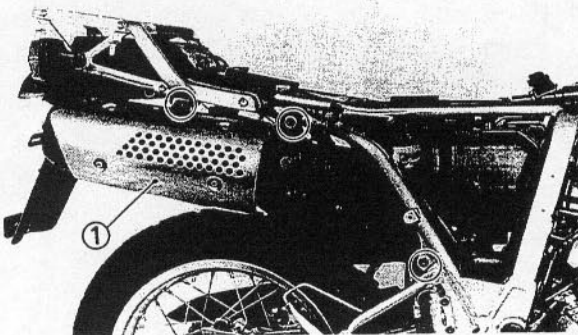
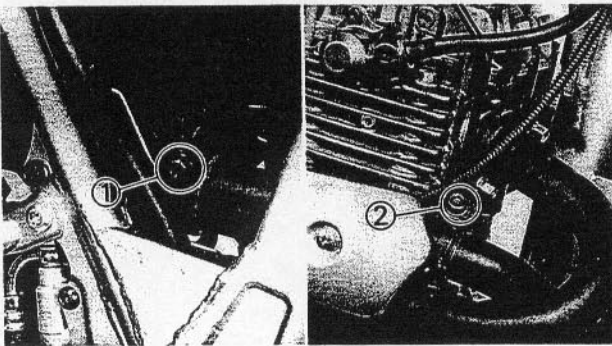

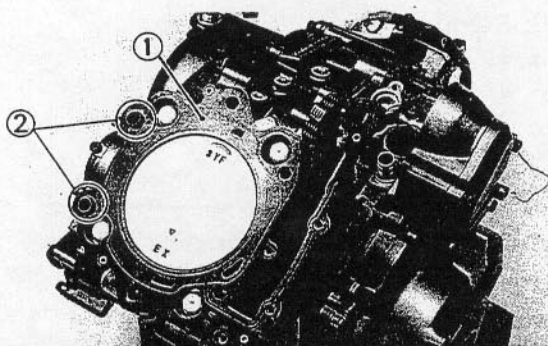

15. Remove:

- Gasket ① (cylinder head)
- Dowel pins ②

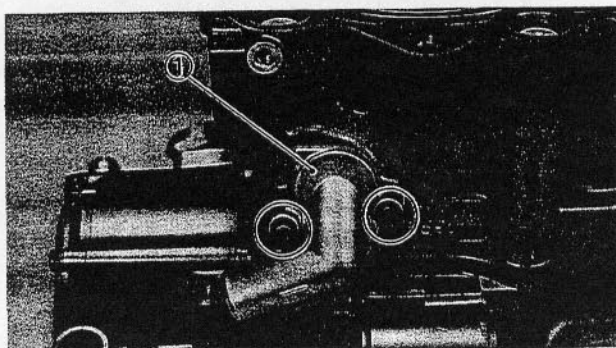

16. Remove:

- Pipe ①

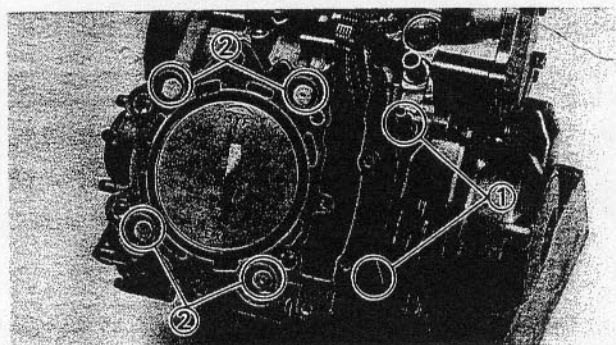

17. Remove:

- Bolts ①
- Bolts ②

NOTE: _____

Working in a crisscross pattern, loosen the bolts 1/4 turn each. Remove them after all are loosened.

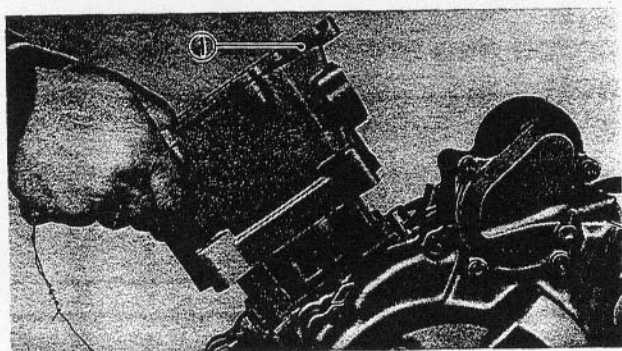

18. Remove:

- Cylinder ①

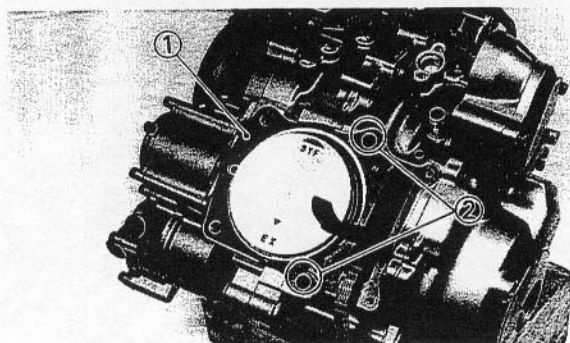

19. Remove:

- Gasket ① (cylinder)
- Dowel pins ②

**NOTE:**

- Fully tighten the tool holding bolts, but make sure the tool body is parallel with the case. If necessary, one screw may be backed out slightly to level tool body.
- As pressure is applied, alternately tap on the front engine mounting boss, transmission shafts, and shift cam.

CAUTION:

Use soft hammer to tap on the case half. Tap only on reinforced portions of case. Do not tap on gasket mating surface. Work slowly and carefully. Make sure the case halves separate evenly. If one end "hangs up," take pressure off the push screw, realign, and start over. If the cases do not separate, check for a remaining case screw or fitting. Do not force.

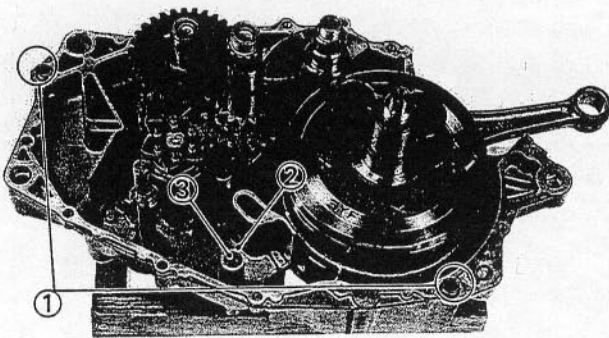

4. Remove:

- Dowel pins ①
- Dowel pin ②
- O-ring ③

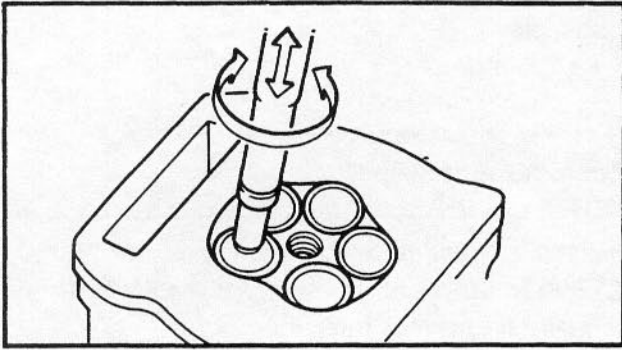

NOTE: _____

To obtain the best lapping results, lightly tap the valve seat while rotating the valve back and forth between your hands.

- Apply fine lapping compound to the valve face and repeat the above steps.

NOTE: _____

Be sure to clean off all compound from the valve face and valve seat after every lapping operation.

- Apply a Mechanic's bluing dye (Dykem) to the valve face.
- Install the valve into the cylinder head.
- Press the valve through the valve guide and onto the valve seat to make a clear pattern.
- Measure the valve seat width again.
If the valve seat width out of specification, reface and lap the valve seat.

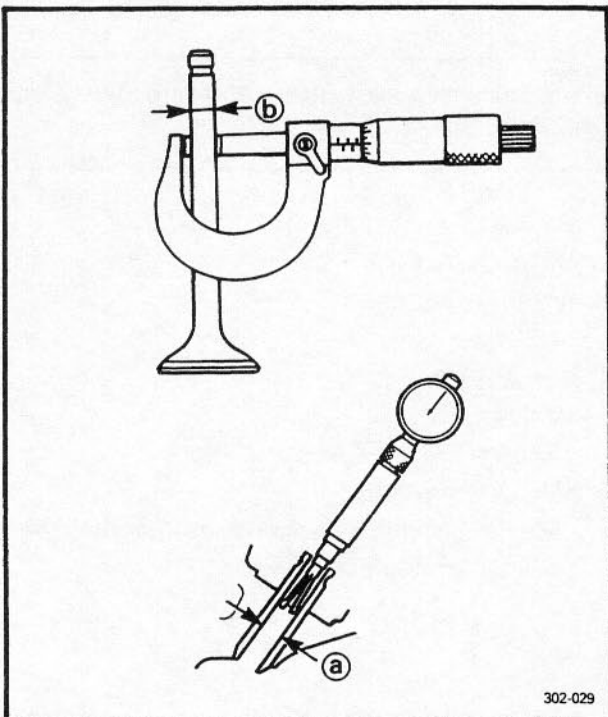

YB243003

VALVE AND VALVE GUIDE

1. Measure:

- Stem-to-guide clearance

$$\text{Stem-to-guide clearance} = \text{Valve guide inside diameter (a)} - \text{Valve stem diameter (b)}$$

Out of specification → Replace valve guide.



Stem-to-guide clearance:

Intake:

0.010 ~ 0.037 mm

(0.0004 ~ 0.0014 in)

< Limit > : 0.08 mm (0.0031 in)

Exhaust:

0.025 ~ 0.052 mm

(0.001 ~ 0.002 in)

< Limit > : 0.10 mm (0.0039 in)

302-029

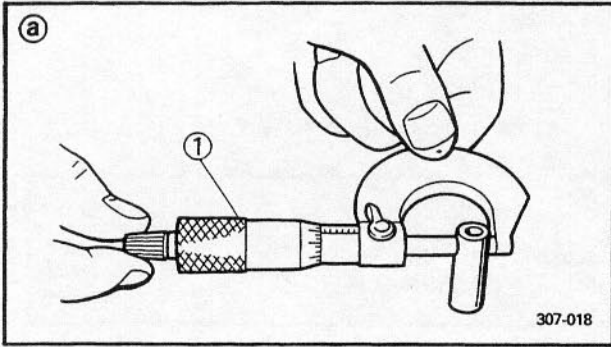

2. Measure:

- Piston pin-to-piston clearance

Measurement steps:

- Measure the piston pin outside diameter (a).
If out of specification, replace the piston pin.



Outside diameter (piston pin):
21.991 ~ 22.000 mm
(0.8658 ~ 0.8661 in)

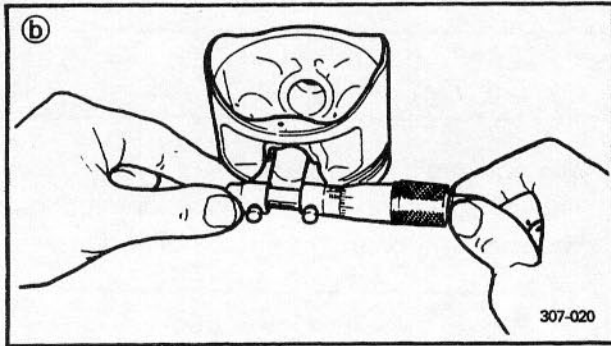

- Measure the piston inside diameter (b).
- Calculate the piston pin-to-piston clearance with following formula:

$$\text{Piston pin-to-piston clearance} = \text{Bore size (piston pin) (b)} - \text{Outside diameter (piston pin) (a)}$$

- If out of specification, replace the piston.



Piston pin-to-piston clearance:
0.004 ~ 0.024 mm
(0.0002 ~ 0.0009 in)
Limit: 0.07 mm (0.003 in)



YB243020

CIRCLIP AND WASHER

1. Inspect:

- Circlips
- Washers

Damage/Looseness/Bends → Replace.

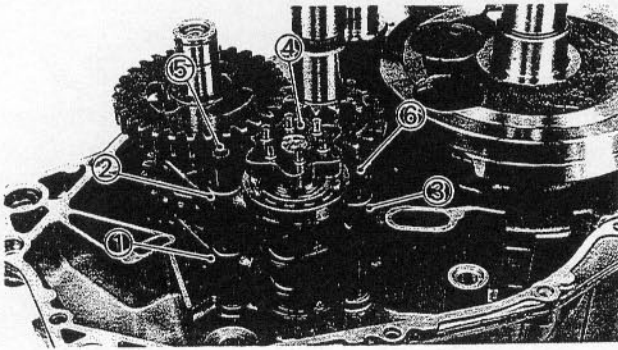

6. Install:

- Shift fork 1 "L" ①
- Shift fork 3 "R" ②
- Shift fork 2 "C" ③
- Shift cam ④
- Guide bar (long) ⑤
- Guide bar (short) ⑥

NOTE:

Install the shift forks with the embossed mark on each shift fork facing right side of the engine.

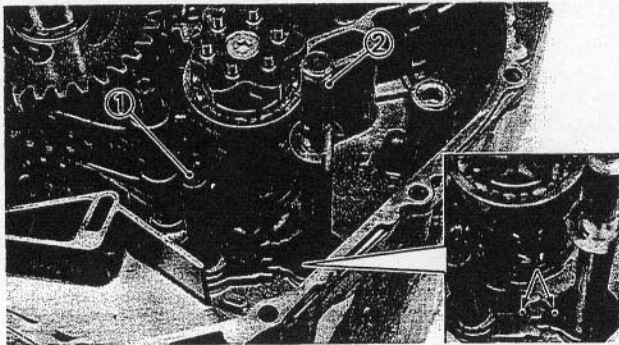

7. Install:

- Shift shaft 2 ①
- Shift shaft ②

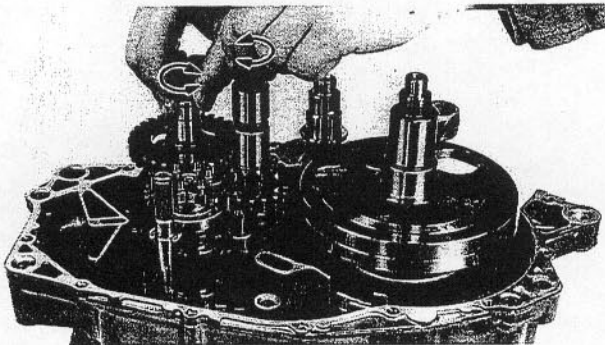

8. Check:

- Transmission operation unsmooth operation
→ Repair.

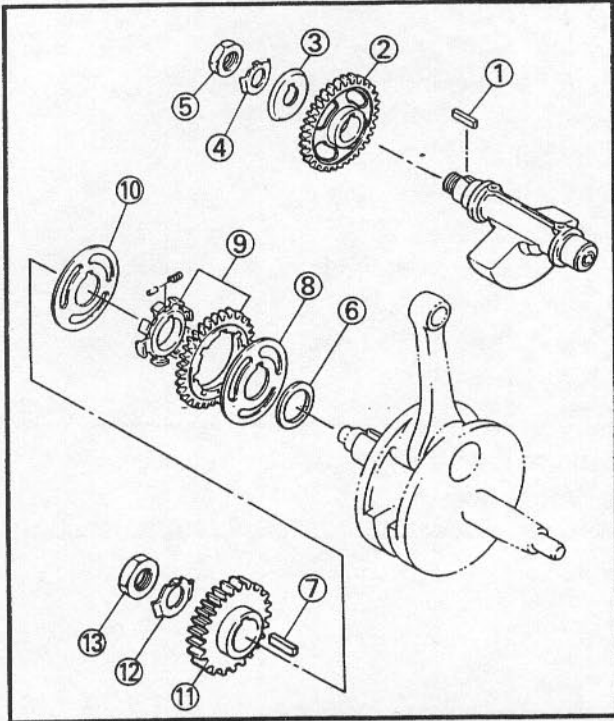

CLUTCH AND BALANCER GEAR

1. Install:

- Key ①
- Balancer gear ②
- Plate ③
- Lock washer ④
- Nut ⑤ (balancer gear)
- Plate washer ⑥
- Key ⑦
- Plate ⑧
- Balancer drive gear ⑨
- Plate ⑩
- Primary drive gear ⑪
- Lock washer ⑫
- Nut ⑬ (primary drive gear)



Nut (balancer gear):

60 Nm (6.0 m•kg, 43 ft•lb)

Nut (primary drive gear):

120 Nm (12.0 m•kg, 85 ft•lb)

NOTE:

- When installing the drive gear, align the punched mark ⑭ on the drive gear with the punched mark ⑮ on the balancer gear.
- Place a folded rag or aluminum plate between the teeth of the balancer drive gear and balancer gear.
- Take care not to damage the gear teeth.

2. Bend the lock washer tab along the nut flats ⑯.

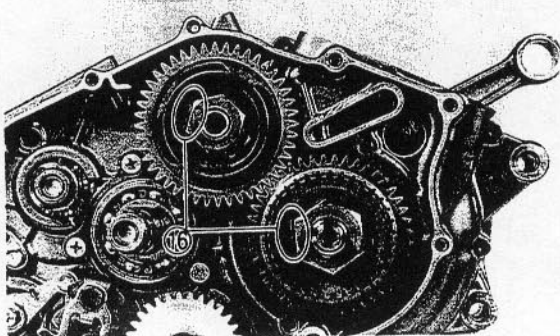
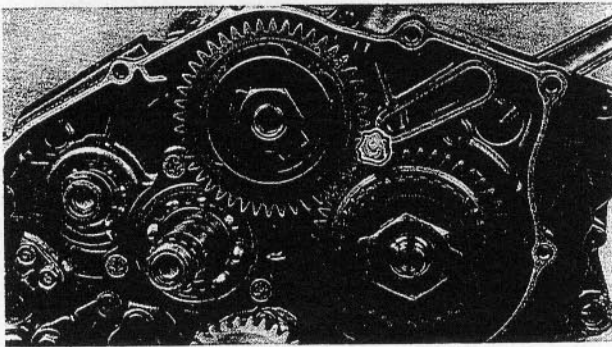
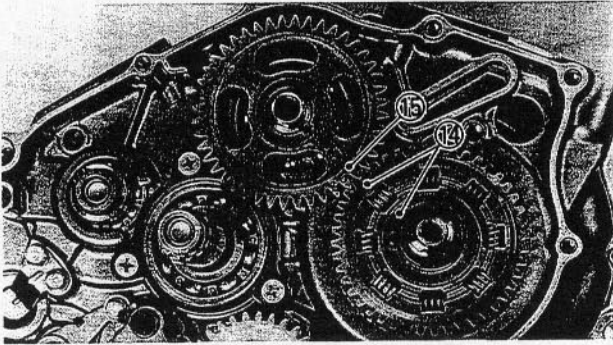

CLICK HERE TO **DOWNLOAD** THE COMPLETE MANUAL

- Thank you very much for reading the preview of the manual.
- You can download the complete manual from: www.heydownloads.com by clicking the link below



- Please note: If there is no response to CLICKING the link, please download this PDF first and then click on it.

CLICK HERE TO **DOWNLOAD** THE COMPLETE MANUAL



CYLINDER

- ① Cylinder head gasket
- ② Cylinder
- ③ O-ring
- ④ Cylinder gasket
- ⑤ Dowel pin

A TIGHTENING SEQUENCE:

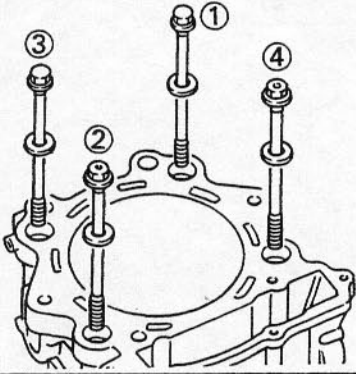

B BORE SIZE:
 100.005 ~ 100.045 mm (3.9372 ~ 3.9388 in)
< LIMIT >:
 < 100.1 mm (3.941 in) >

C PISTON-TO-CYLINDER CLEARANCE:
 0.050 ~ 0.070 mm (0.0020 ~ 0.0028 in)
< LIMIT >:
 < 0.15 mm (0.0059 in) >

42 Nm (4.2 m·kg, 30 ft·lb)

10 Nm (1.0 m·kg, 7.2 ft·lb)

D USE NEW ONE

38 Nm (3.8 m·kg, 27 ft·lb)

D USE NEW ONE

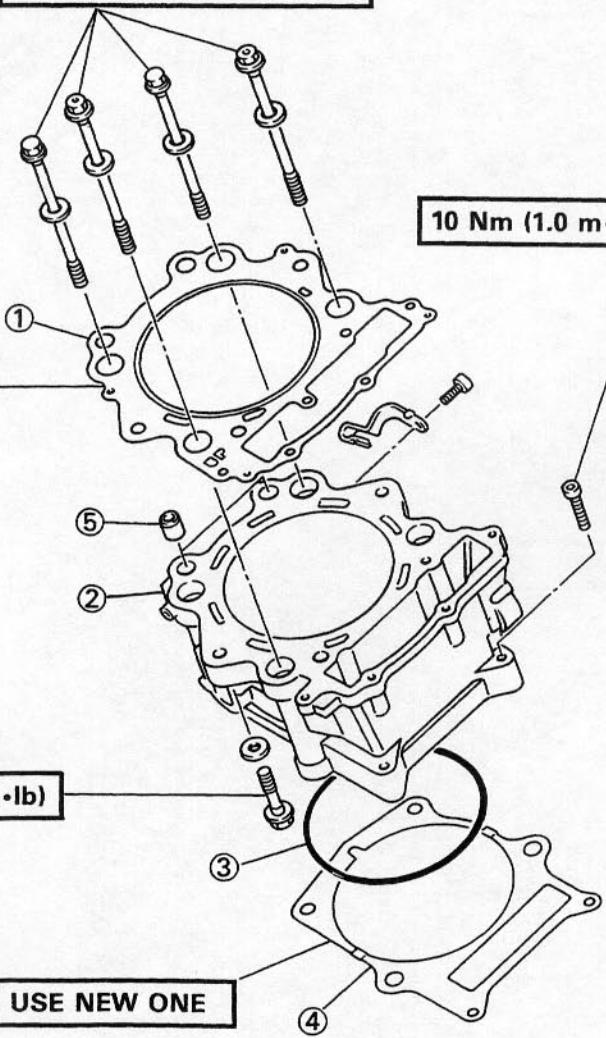

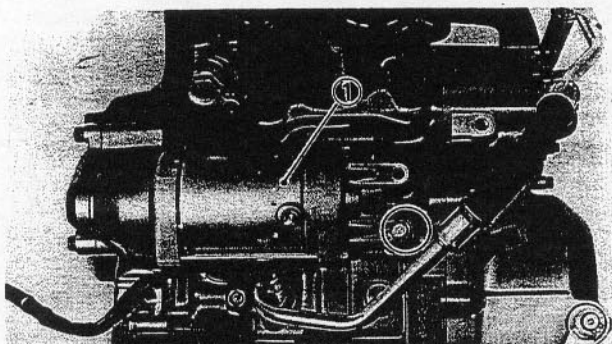

5. Install:

- Starter motor ①



Bolt (starter motor):
10 Nm (1.0 m•kg, 7.2 ft•lb)

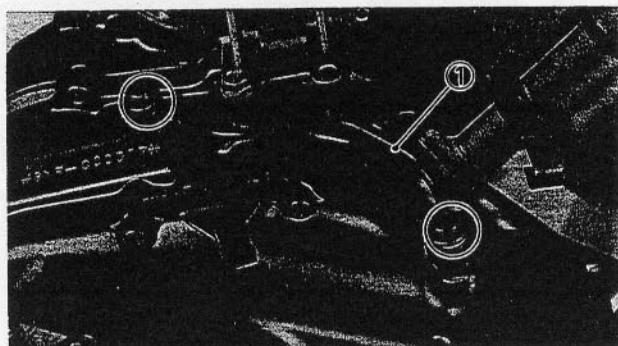

6. Install:

- Oil pipe ①



Union bolt:
20 Nm (2.0 m•kg, 14 ft•lb)

Bolt:
10 Nm (1.0 m•kg, 7.2 ft•lb)

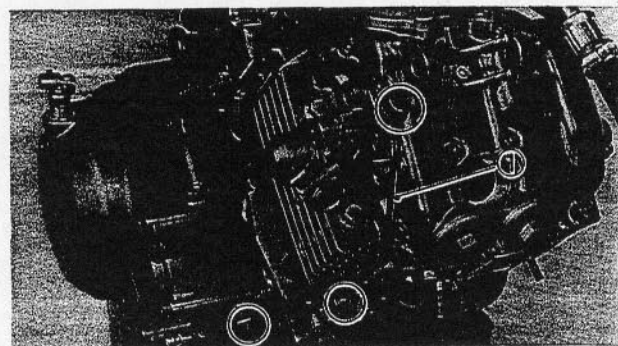

7. Install:

- Oil pipe ①



Union bolt (oil pipe):
20 Nm (2.0 m•kg, 14 ft•lb)

YB244014

REMountING ENGINE

When remounting the engine, reverse the removal procedure. Note the following points.

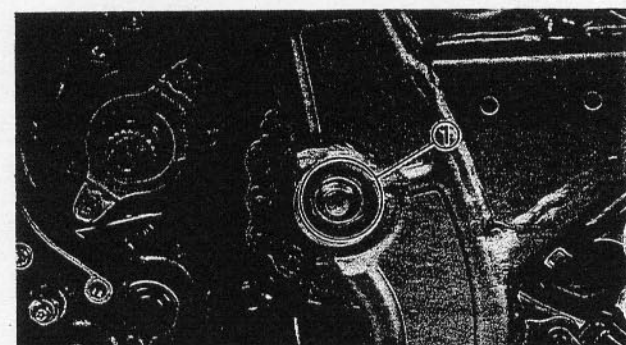

1. Install:

- Pivot shaft ①
- Mounting bolt ② (front—upper)
- Mounting bolt ③ (rear—lower)
- Mounting bolts ④ (front—lower)

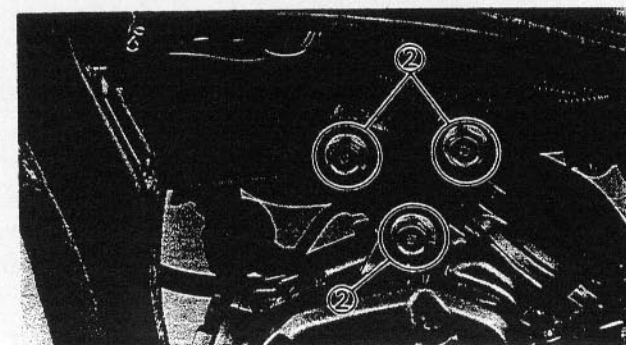

RADIATOR

COOL

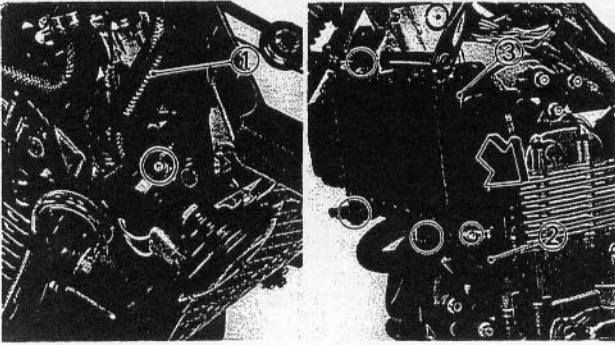

4. Disconnect:
 - Radiator hose ① (from conduction)
 - Radiator hose ② (to water pump)

5. Remove:
 - Radiator assembly ③

6. Remove:
 - Fan motor assembly ①
 - Radiator protector ②

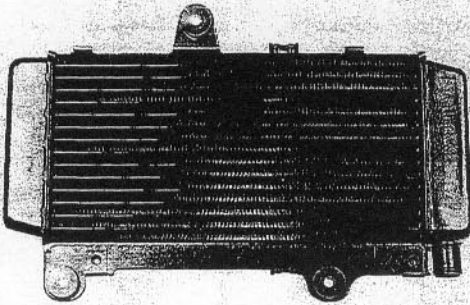
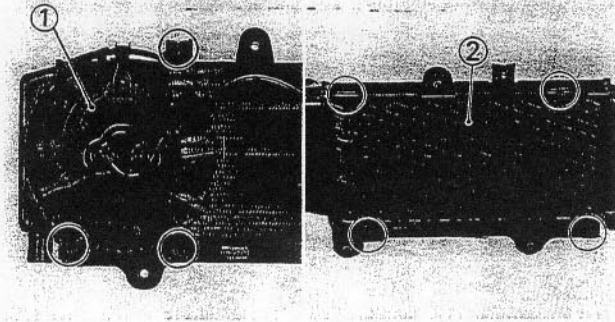

YB351002

INSPECTION

1. Inspect:
 - Radiator
 - Obstruction → Blow out with compressed air through rear of radiator.
 - Flattened fins → Repair.
 - Coolant hoses
 - Cracks/Damage → Replace.

2. Inspect:
 - Radiator cap
 - Vacuum valve

Inspection steps:

- Measure radiator cap pressure using the radiator cap tester.
- Check vacuum valve for spring tension and seating condition.



Radiator cap tester:
P/N. YU-24460-1, 90890-01325
Adapter:
P/N. YU-33984, 90890-01352



SECTIONAL VIEW

- ① Jet needle (primary)
- ② Valve seat
- ③ Needle valve
- ④ Needle jet (primary)
- ⑤ Main jet (primary)
- ⑥ Pilot screw
- ⑦ Jet needle (secondary)
- ⑧ Needle jet (secondary)
- ⑨ Main jet (secondary)

- A** Primary carburetor
- B** Secondary carburetor

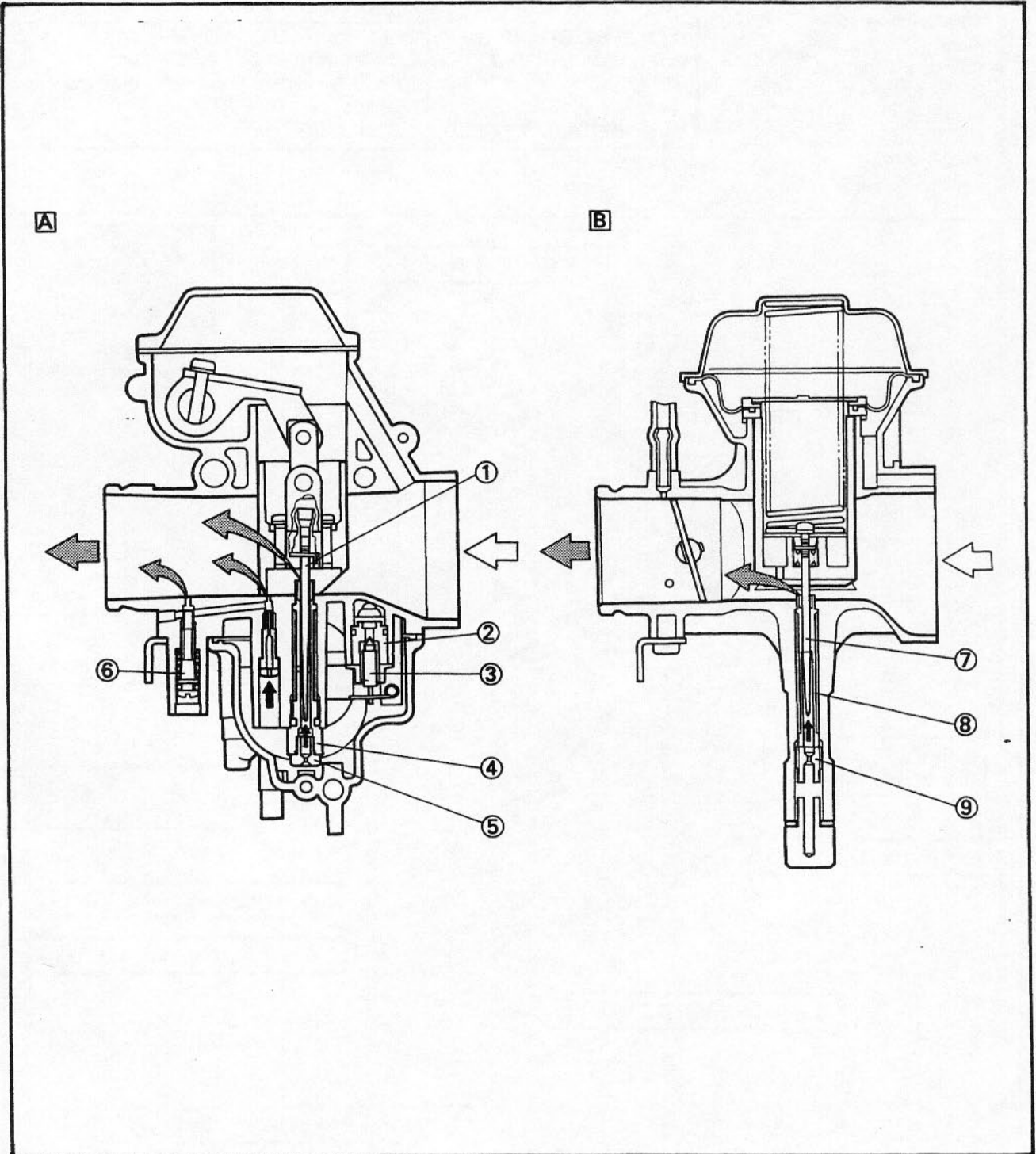
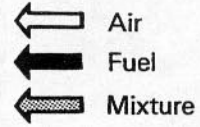

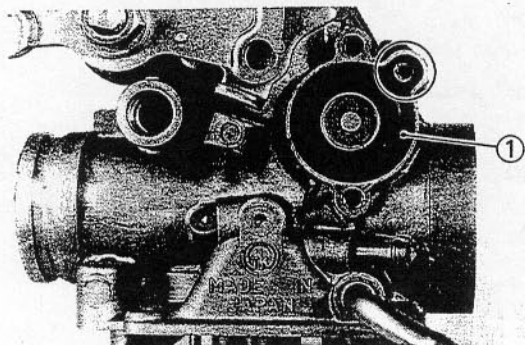

7. Install:

- Rubber diaphragm ① (coasting enricher)

NOTE: _____

Match the tab on the rubber diaphragm to the matching recess in the coasting enricher.

8. Connect:

- Starter plunger (to the starter cable)

9. Install:

- Throttle stop screw

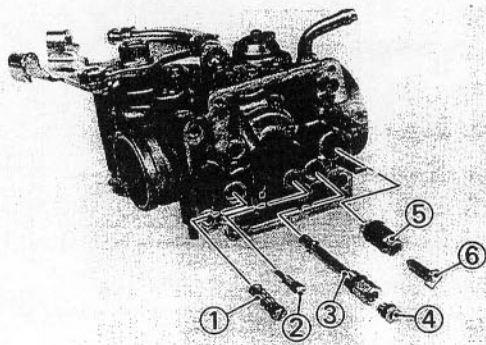

10. Install:

- Pilot screw ①
- Pilot jet ②
- Needle jet ③
- Main jet ④
- Valve seat ⑤
- Needle valve ⑥ (with float)

| | |
|---|---|
|  | <p>Needle jet: 2 Nm (0.2 m•kg, 1.4 ft•lb)</p> <p>Main jet: 1.6 Nm (0.16 m•kg, 1.2 ft•lb)</p> <p>Screw (valve seat): 2 Nm (0.2 m•kg, 1.4 ft•lb)</p> |
|---|---|

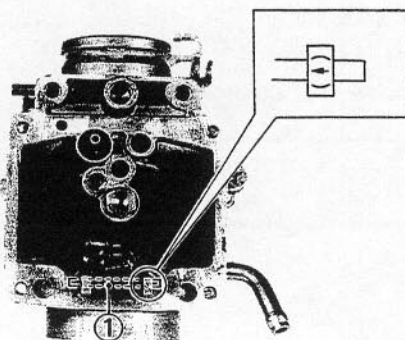

11. Install:

- Float pin ①

NOTE: _____

Install the float pin reverse to the arrow.

CHASSIS

FRONT WHEEL

- ① Wheel axle
- ② Collar
- ③ Dust cover
- ④ Oil seal
- ⑤ Bearing
- ⑥ Collar
- ⑦ Front wheel
- ⑧ Bearing
- ⑨ Gear unit (speedometer)
- ⑩ Damper rubber
- ⑪ Disc cover

| TIRE AIR PRESSURE (COLD): | | |
|--------------------------------|--|--|
| Cold tire pressure | Front | Rear |
| Up to 90 kg (198 lb) load* | 200 kPa (2.00 kg/cm ² , 28 psi) | 200 kPa (2.00 kg/cm ² , 28 psi) |
| 90 kg (198 lb) ~ Maximum load* | 200 kPa (2.00 kg/cm ² , 28 psi) | 225 kPa (2.25 kg/cm ² , 32 psi) |

*Load is the total weight of cargo, rider, passenger and accessories.

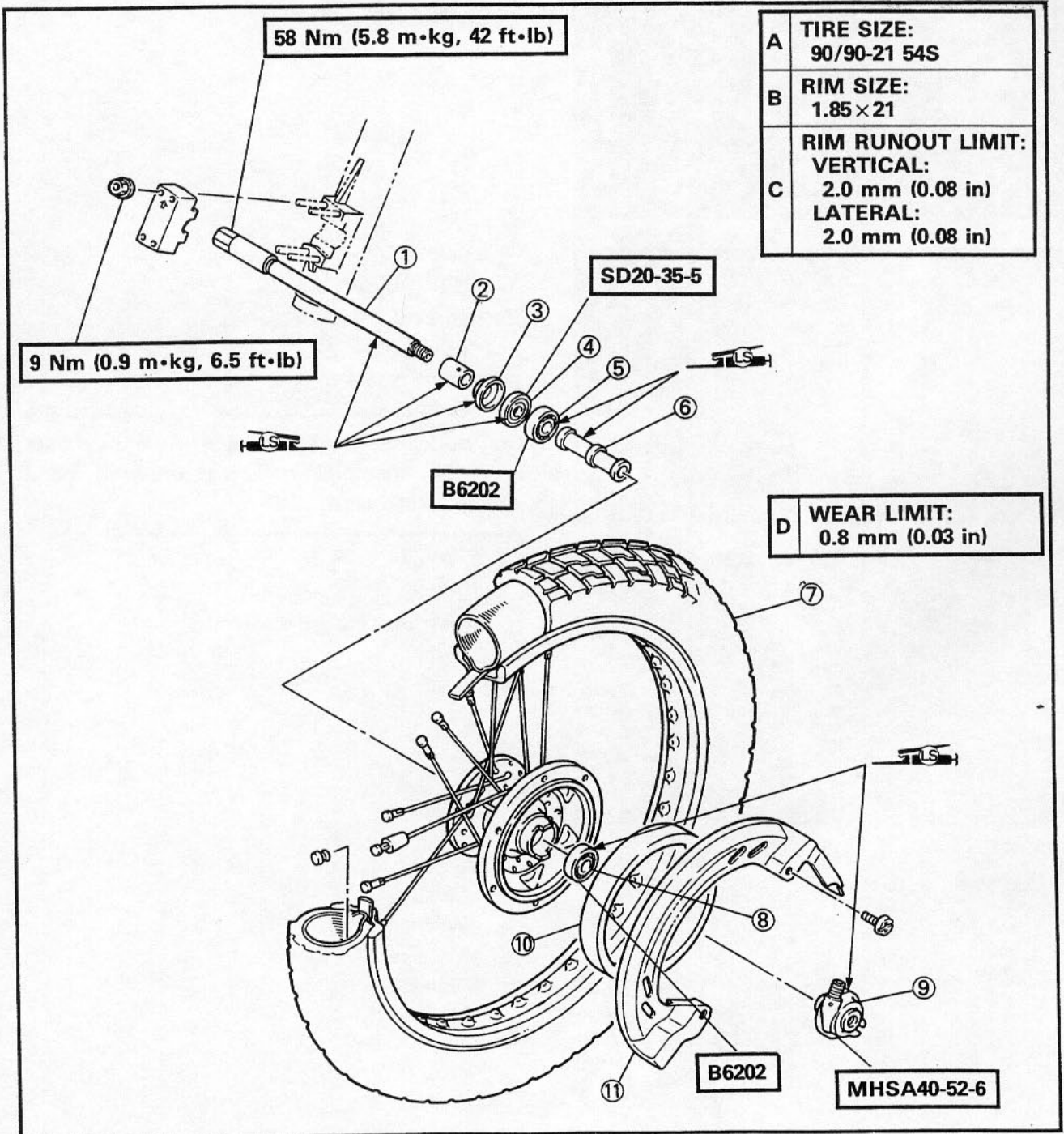



4. Check:

- Oil seals
- Wheel bearings

Refer to the "FRONT WHEEL—INSPECTION" section.

5. Inspect:

- Caliper bracket ①
Cracks/Damage → Replace.

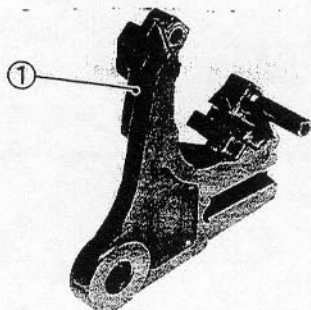

INSTALLATION

Reverse the "Removal" procedure.
Note the following points.

1. Lubricate:

- Wheel axle
- Bearings
- Oil seals (lip)



Lithium soap base grease

2. Adjust:

- Drive chain slack



Drive chain slack:
20 ~ 45 mm (0.79 ~ 1.77 in)

Refer to the "DRIVE CHAIN SLACK ADJUSTMENT" section in the CHAPTER 3.

3. Tighten:

- Axle nut
- Locknut



Axle nut:
100 Nm (10.0 m•kg, 72 ft•lb)
Locknut (chain puller):
15 Nm (1.5 m•kg, 11 ft•lb)

2. Remove:

- Bolts (caliper body)
- Retaining bolts
- Brake pads
- Pad spring

Refer to the "BRAKE PAD REPLACEMENT" section.

3. Remove:

- Union bolt ①
- Copper washers ②

NOTE: _____

Place the container under the caliper to catch the standing brake fluid.

4. Remove:

- Caliper bracket ①
- Piston ②
- Dust seal ③
- Piston seal ④

Removal steps:

- Blow compressed air into the tube joint opening to force out the piston from the caliper body.

⚠ WARNING _____

- Never try to pry out the piston.
- Cover the piston with a rag. Use care so that piston does not cause injury as it is expelled from the cylinder.

Rear Brake

1. Loosen:

- Union bolt ①

NOTE: _____

Loosen slightly so that brake fluid does not leak out.

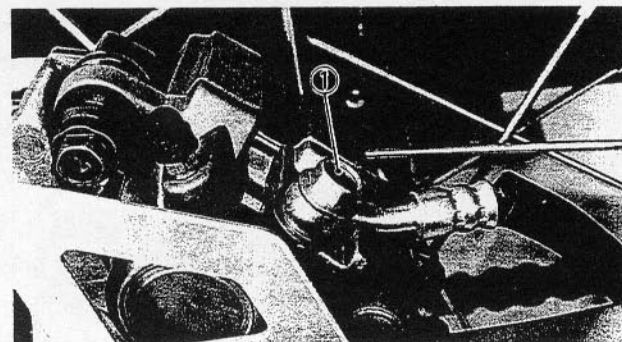
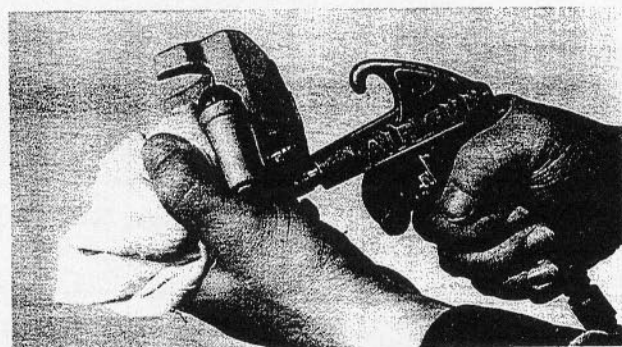
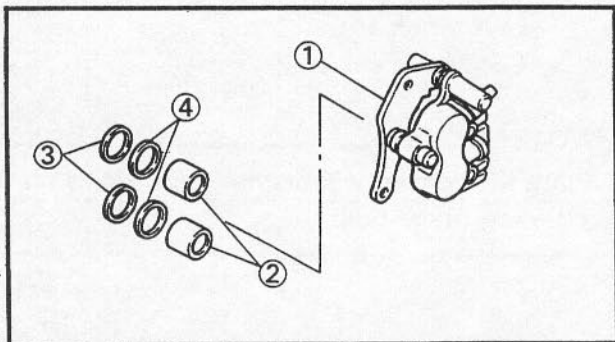
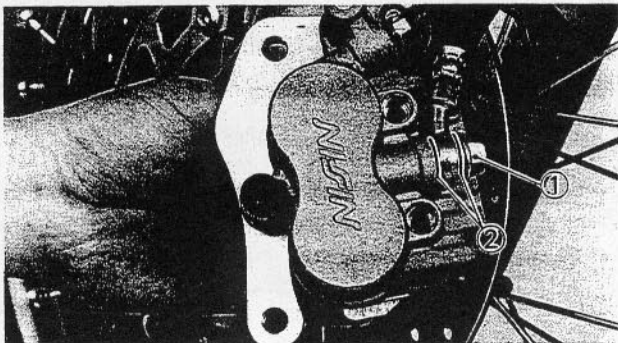

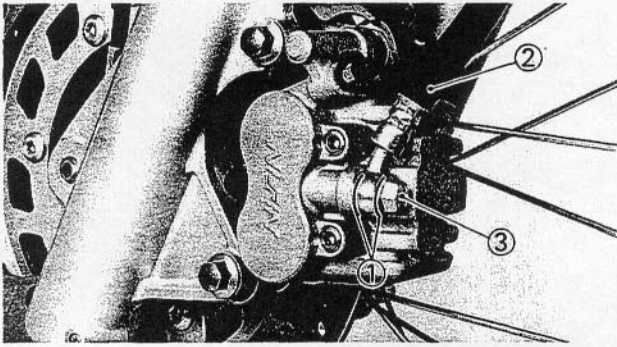

4. Install:
- Copper washers ①
 - Brake hose ②
 - Union bolt ③

 **Union bolt:**
26 Nm (2.6 m•kg, 19 ft•lb)

CAUTION: _____

When installing the brake hose, lightly touch the pipe portion (a) of the brake hose with the projection (b) on brake caliper.

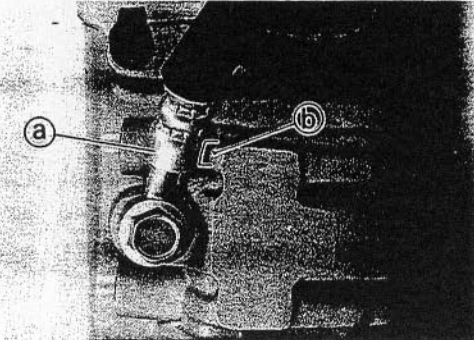

! WARNING _____

- Proper hose routing is essential to insure safe motorcycle operation. Refer to the "CABLE ROUTING" section in the CHAPTER 2.
- Always use new copper washers.

5. Fill:
- Brake fluid

 **Recommended brake fluid:**
DOT #4

CAUTION: _____

Brake fluid may erode painted surfaces or plastic parts. Always clean up spilled fluid immediately.

! WARNING _____

- Use only the designated quality brake fluid: otherwise, the rubber seals may deteriorate, causing leakage and poor brake performance.
- Refill with the same type of brake fluid; mixing fluids may result in a harmful chemical reaction and lead to poor performance.
- Be careful that water does not enter the master cylinder when refilling. Water will significantly lower the boiling point of the fluid and may result in vapor lock.

FRONT FORK

- ① Cap bolt
- ② O-ring
- ③ Spacer
- ④ Spring seat
- ⑤ Fork spring
- ⑥ Inner fork tube
- ⑦ Damper rod
- ⑧ Oil lock piece
- ⑨ Retaining clip
- ⑩ Dust seal
- ⑪ Oil seal
- ⑫ Washer
- ⑬ Guide bush
- ⑭ Outer fork tube
- ⑮ Axle holder
- ⑯ Fork boot
- ⑰ Cable band (speedometer cable)

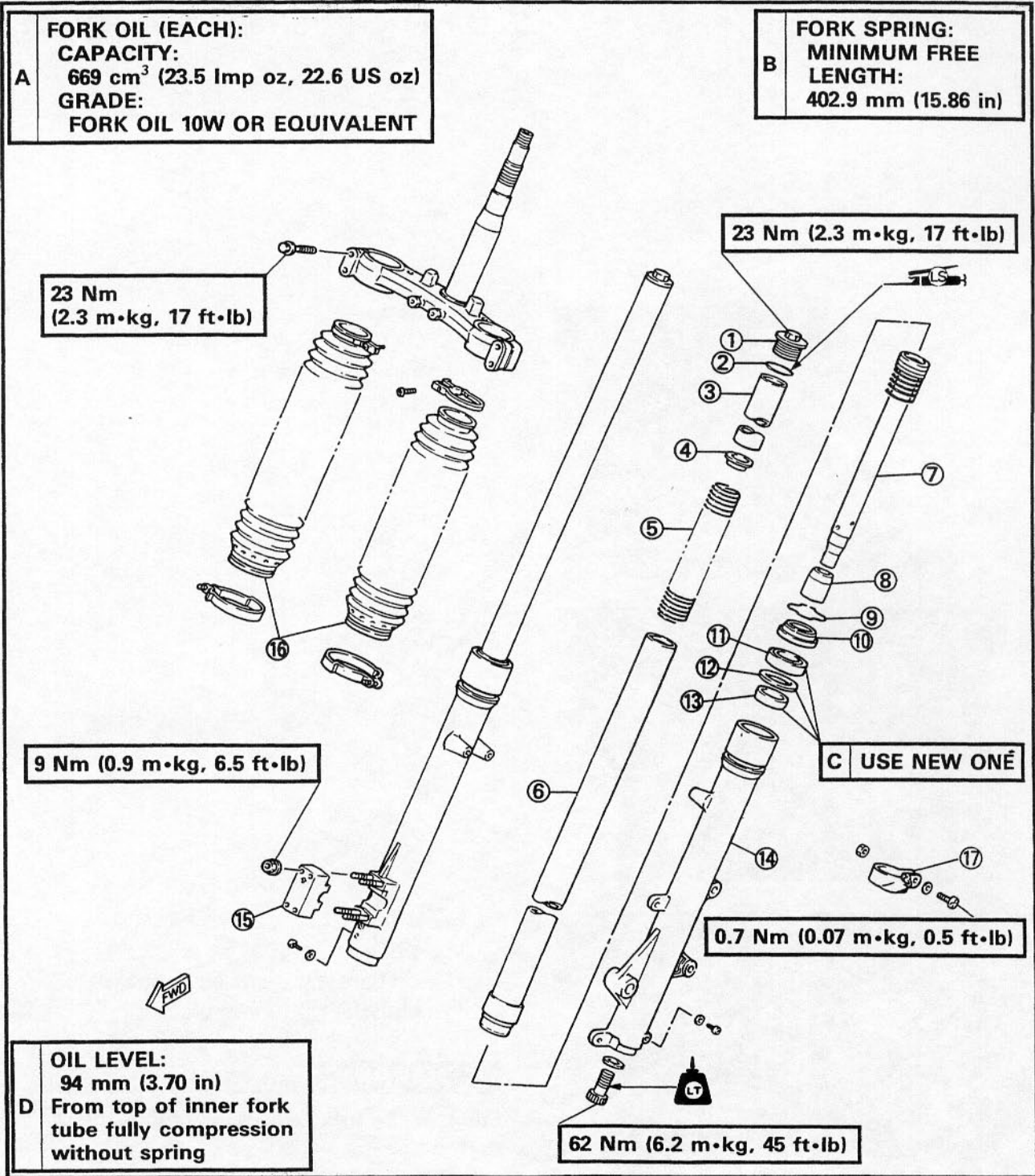

**⚠ WARNING**

Proper hose routing is essential to insure safe motorcycle operation. Refer to the "CABLE ROUTING" section in the CHAPTER 2.

5. Install:

- Front wheel



Wheel axle:

58 Nm (5.8 m·kg, 42 ft·lb)

Nut (axle holder):

9 Nm (0.9 m·kg, 6.5 ft·lb)

Refer to "FRONT WHEEL—INSTALLATION" section.

NOTE: _____

Apply a light coat of lithium soap base grease onto the clutch cable end.

13. Connect:

- Bands

14. Install:

- Guard (left)

15. Install:

- Throttle grip
- Handlebar switch (right)
- Grip end

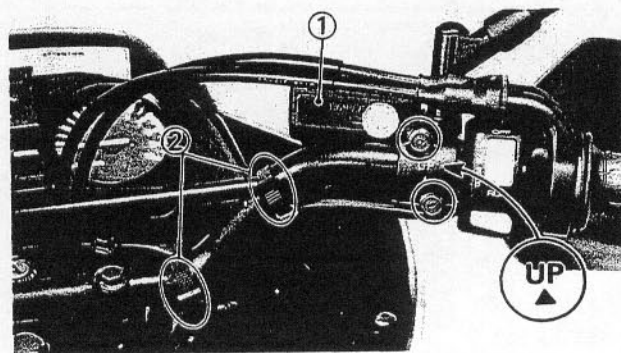
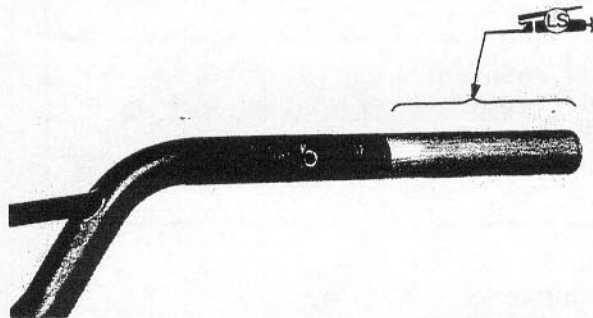
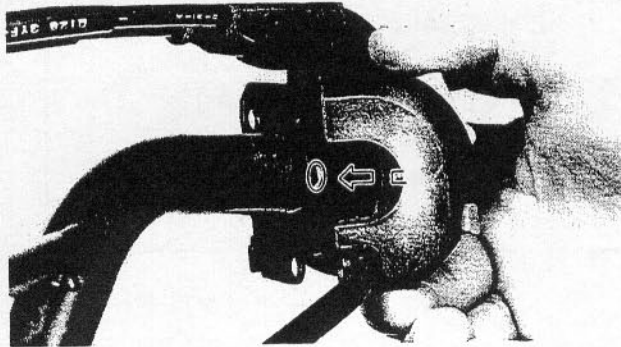

 **Grip end:**
26 Nm (2.6 m•kg, 19 ft•lb)

NOTE: _____

- Before installing the throttle grip onto the handlebar, apply a light coat of lithium soap base grease onto the handlebar end and install the throttle grip to the handlebar.
- When installing the handlebar switch (right) make sure its projection fits into the hole as shown.

16. Install:

- Brake master cylinder ①

NOTE: _____

- Install the master cylinder bracket with the "UP" mark facing upward.
- Tighten first the upper bolt, then the lower bolt.

 **Bolt (master cylinder bracket):**
7 Nm (0.7 m•kg, 5.1 ft•lb)

17. Connect:

- Bands ②

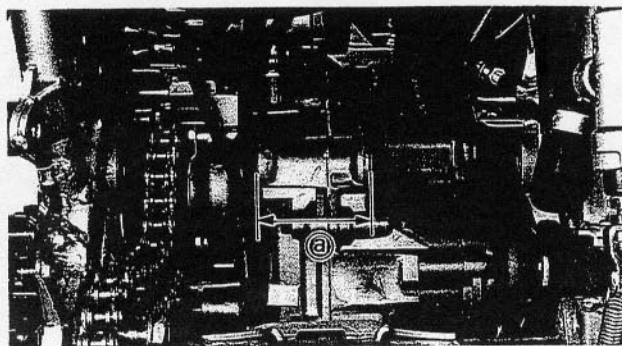

YB276005

SIDE CLEARANCE ADJUSTMENT

1. Measure:

- Engine mounting boss width (a)

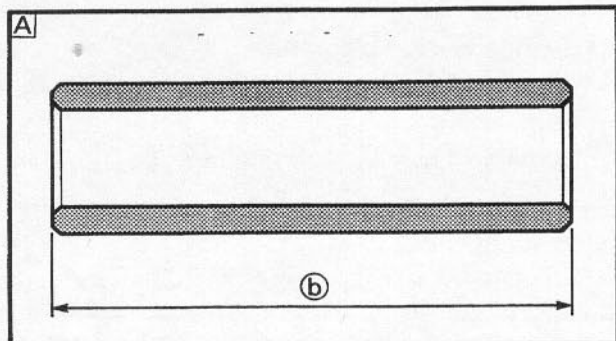

2. Measure:

- Bush length (b) and (c)
- Out of specification → Replace.



Specified length:

b: 80.95 ~ 81.10 mm
(3.187 ~ 3.193 in)

c: 74.90 ~ 75.00 mm
(2.949 ~ 2.953 in)

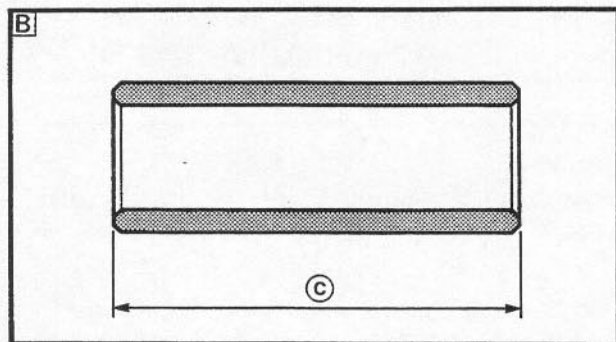

- A** Bush (right hand)
- B** Bush (left hand)

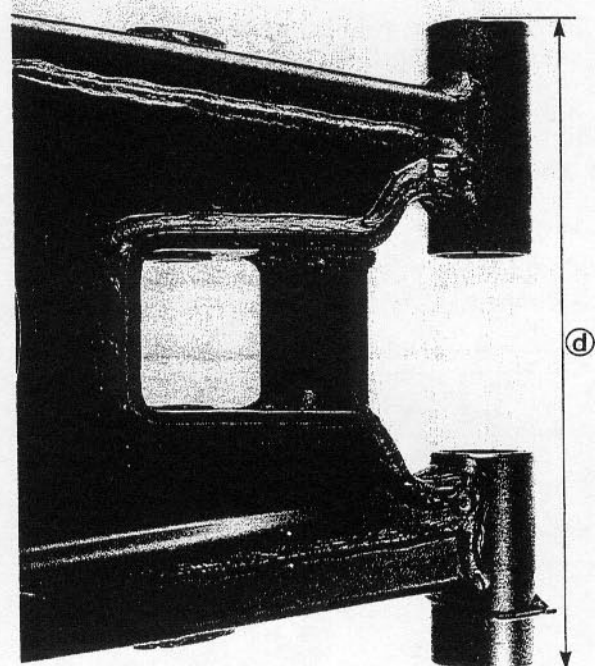

3. Measure:

- Pivot width (d)

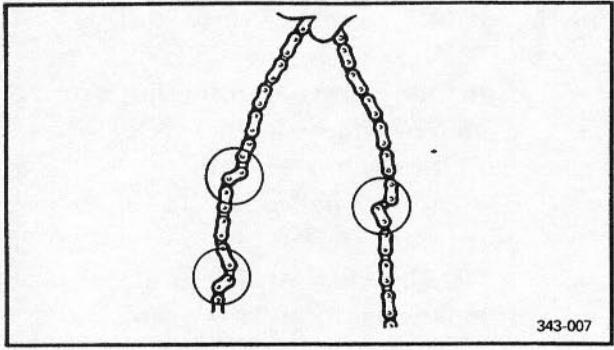

343-007

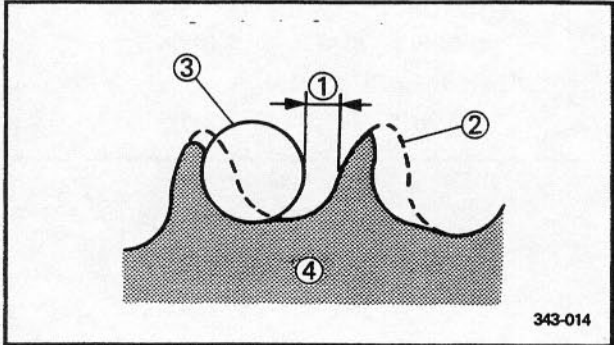

343-014

5. Inspect:
- Drive chain stiffness
Stiff → Clean and lubricate or replace.

6. Inspect:
- Drive sprocket
 - Driven sprocket
More than 1/4 teeth ① wear → Replace sprocket.
Bent teeth → Replace sprocket.

- ② Correct
- ③ Roller
- ④ Sprocket

Replacement steps:

- Straighten the lock washer tabs and remove the driven sprocket.
- Install a new driven sprocket and lock washers.

⚠ WARNING _____

Always use new lock washers.

| | |
|---|--|
|  | <p>Nut (driven sprocket): 60 Nm (6.0 m•kg, 43 ft•lb)</p> |
|---|--|

- Bend the washer tabs along the nut flats.

YB277003

INSTALLATION

Reverse the "REMOVAL" procedure.
Note the following points.

1. Install:
- Drive chain
 - Swingarm
Refer to the "REAR SHOCK ABSORBER AND SWINGARM" section.



YB281002

CHECKING SWITCH FOR TERMINAL CONNECTION

Before checking the switch, refer to the connection chart as shown above and check for the correct terminal connection (closed circuit) by the color combination.

To explain how to check the switch, the main switch taken for example in the following.

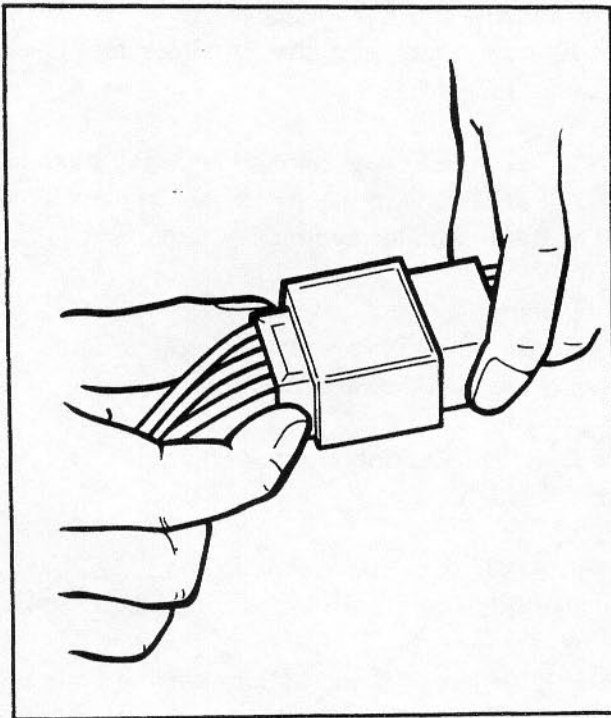

1. Disconnect the main switch coupler from the wireharness.

CAUTION: _____

Never disconnect the main switch coupler by pulling the leads. Otherwise, leads may be pulled off the terminals inside the coupler.

2. Inspect whether any lead is off the terminal inside the coupler. If it is, repair it.

NOTE: _____

If the coupler is clogged with mud or dust, blow it off by compressed air.



- Connect the pocket tester ($\Omega \times 1\text{ k}$) to the ignition coil.

Tester (+) lead \rightarrow Spark plug lead ①
 Tester (-) lead \rightarrow \oplus terminal

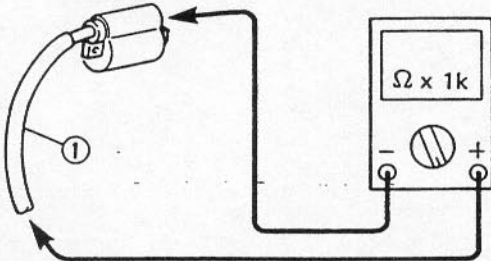

- Check the secondary coil for specified resistance.



Secondary coil resistance:
 10.4 ~ 15.6k Ω at 20°C (68°F)
 (Spark plug lead - \oplus terminal)

BOTH MEET SPECIFICATIONS

Ignition coil is faulty, replace it.

7. Main switch

- Disconnect the main switch coupler from the wire harness.
- Check the switch component for the continuity between "Red ① and Brown ②". Refer to the "CHECKING OF SWITCHES" section.

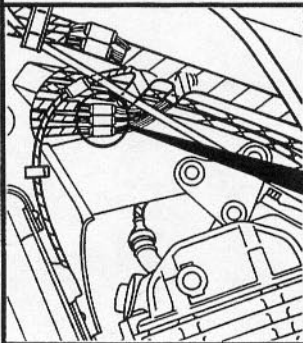

| | R | Br | L | L/R |
|------|---|----|---|-----|
| ON | ○ | ○ | ○ | ○ |
| OFF | | | | |
| LOCK | | | | |
| P | ○ | | | ○ |

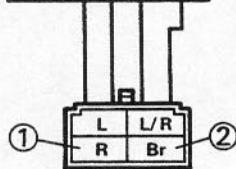

INCORRECT

Main switch is faulty, replace it.

CORRECT

*



8. Neutral switch

- Disconnect the neutral switch lead from the wireharness.
- Check the switch component for the continuity between "Sky blue ① and Ground". Refer to the "CHECKING OF SWITCHES" section.

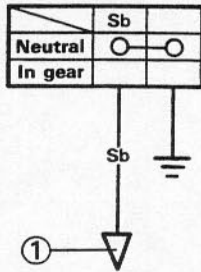
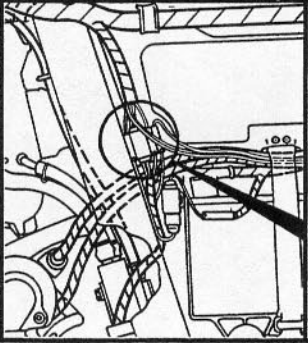

INCORRECT

Neutral switch is faulty, replace it.

CORRECT

9. Sidestand switch

- Disconnect the sidestand switch coupler from the wireharness.
- Check the switch component for the continuity between "Black/White ① and Black ②". Refer to the "CHECKING OF SWITCHES" section.

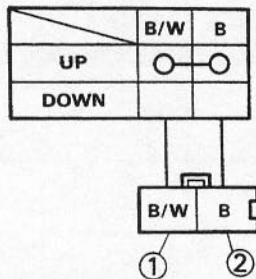
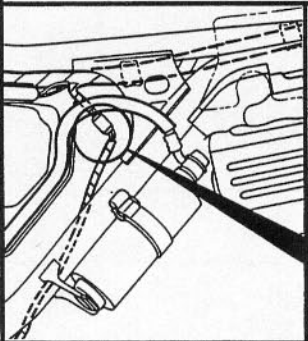

INCORRECT

Sidestand switch is faulty, replace it.

CORRECT

10. Clutch switch

- Disconnect the clutch switch coupler from the wireharness.
- Check the clutch switch component for the continuity between "Black/Yellow ① and Black ②". Refer to the "CHECKING OF SWITCHES" section.



TROUBLESHOOTING

THE BATTERY IS NOT CHARGED.

Procedure

Check:

1. Fuse (main)
2. Battery
3. Charging voltage
4. Stator coil resistance
5. Wiring connection
(Entire charging system)

NOTE:

- Remove the following parts before troubleshooting.
 - 1) Seat
 - 2) Side cover (left)
- Use the following special tool(s) in this troubleshooting.



Inductive tachometer:
P/N YU-08036-A, 90890-03113



Pocket tester:
P/N YU-03112, 90890-03112

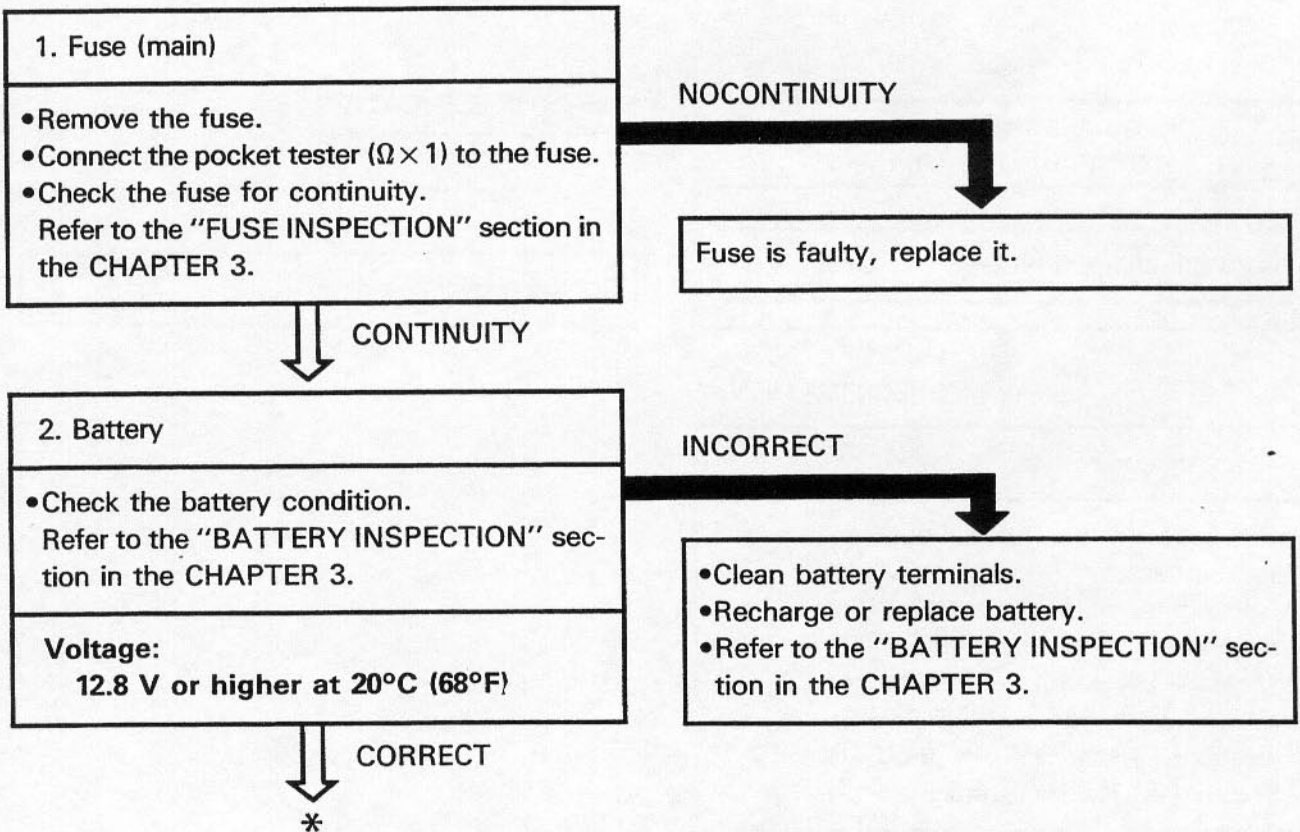



2. Neutral switch

- Disconnect the neutral switch lead from the wireharness.
- Check the switch component for the continuity between "Sky blue ① and Ground". Refer to the "CHECKING OF SWITCHES" section.

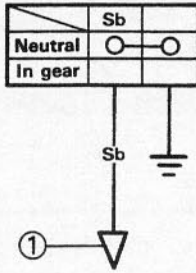
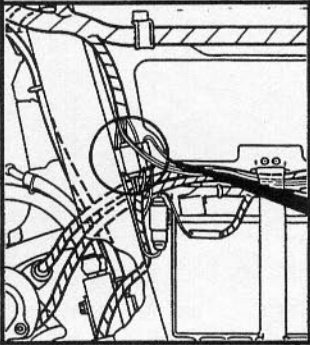

INCORRECT

Neutral switch is faulty, replace it.

CORRECT

3. Voltage

- Connect the pocket tester (DC20V) to the bulb socket connector.

Tester (+) lead → Brown lead ①
 Tester (-) lead → Black lead ②

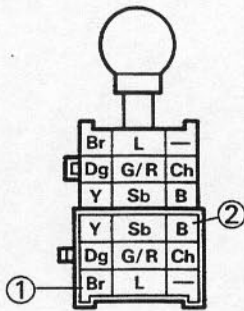
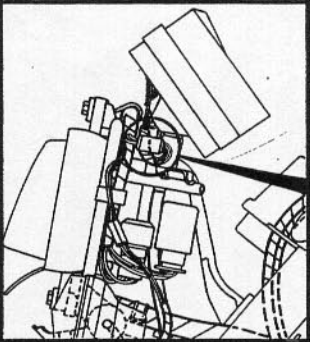

OUT OF SPECIFICATION

Wiring circuit from main switch to bulb socket connector is faulty, repair.

MEETS SPECIFICATION (12V)

 **Thermo unit:**
15 Nm (1.5 m•kg, 11 ft•lb)
Water resistant sealant

CAUTION: _____
Avoid overtightening.

OUT OF SPECIFICATION

Thermo unit is faulty, replace it.

MEET SPECIFICATIONS

5. Voltage

- Connect the pocket tester (DC20V) to the temperature gauge leads.

Tester (+) lead → Brown lead ①
Tester (-) lead → Black lead ②

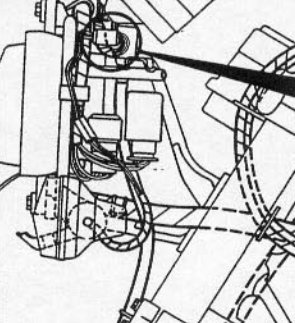

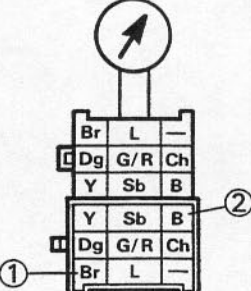

- Turn the main switch to "ON".
- Check for voltage (12V) on the "Brown" lead at the temperature gauge connector.

OUT OF SPECIFICATION

Wiring circuit from main switch to temperature gauge connector, repair.

MEETS SPECIFICATION (12V)

6. Wiring connection

Check the entire cooling system for connections. Refer to the "WIRING DIAGRAM" section.

POOR CONNECTION

Correct.

CORRECT

Replace tempmeter gauge.

CLICK HERE TO **DOWNLOAD** THE COMPLETE MANUAL

- Thank you very much for reading the preview of the manual.
- You can download the complete manual from: www.heydownloads.com by clicking the link below



- Please note: If there is no response to CLICKING the link, please download this PDF first and then click on it.

CLICK HERE TO **DOWNLOAD** THE COMPLETE MANUAL