

SP200

SUZUKI

SP200

SERVICE MANUAL

99500-41072-03E

(英)

CLICK HERE TO **DOWNLOAD** THE COMPLETE MANUAL

- Thank you very much for reading the preview of the manual.
- You can download the complete manual from: www.heydownloads.com by clicking the link below



- Please note: If there is no response to CLICKING the link, please download this PDF first and then click on it.

CLICK HERE TO **DOWNLOAD** THE COMPLETE MANUAL

FUEL LINE

Inspect: 1 000 km (600 miles), 5 000 km (3 000 miles), 10 000 km (6 000 miles), 15 000 km (9 500 miles)

Replace: Every 4 years

Inspect the fuel line for damage and fuel leakage. If any defects are found, the fuel line must be replaced.

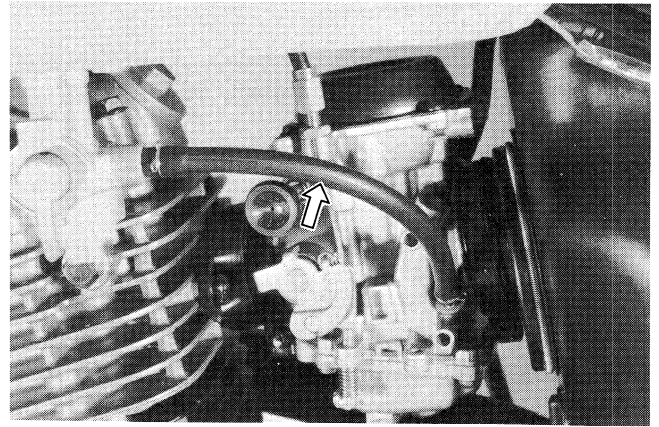

FUEL STRAINER CUP

Clean: 1 000 km (600 miles), 10 000 km (6 000 miles)

Clean the strainer cup with non-flammable cleaning solvent.

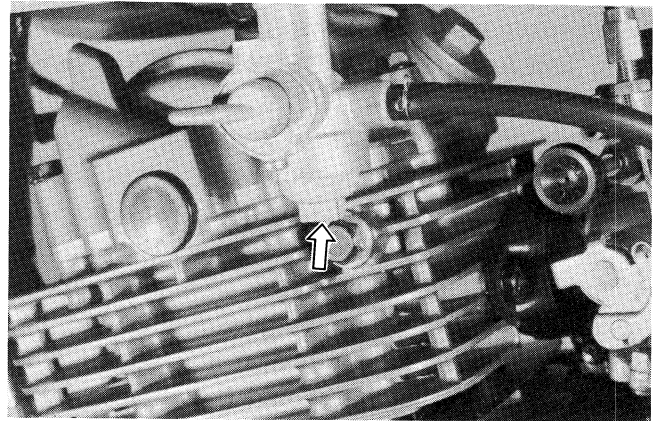

ENGINE OIL AND OIL FILTER

Replace (Change): 1 000 km (600 miles), 5 000 km (3 000 miles), 10 000 km (6 000 miles), 15 000 km (9 500 miles)

The oil should be changed while the engine is hot. Oil filter replacement at the above intervals should be done together with engine oil change.

- Keep the motorcycle upright, supported by jack.
- Place an oil pan below the engine and remove the engine oil drain plug ① and oil filler cap ② to drain engine oil.
- Remove the oil filter cap by removing the three nuts ③.
- Pull out the old oil filter ④ and install the new one.
- Replace the oil filter cap and tighten the nuts ③ securely.

NOTE:

Before installing the oil filter and oil filter cap, check to be sure that the spring ⑤ and new O-rings (⑥ and ⑦) are installed correctly.

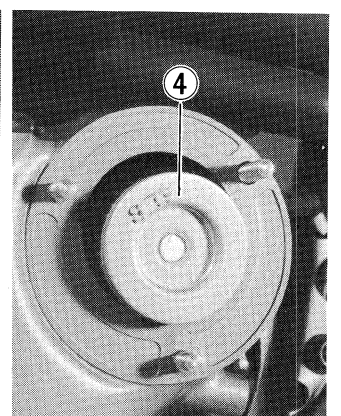
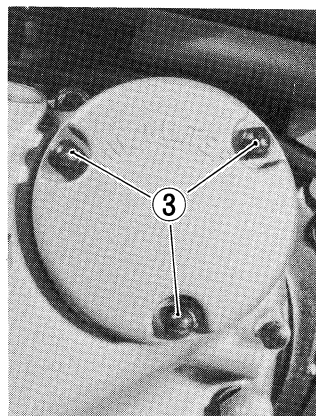
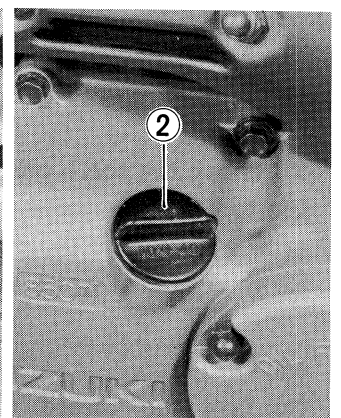
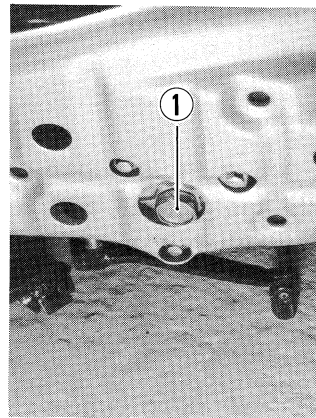

2-19 PERIODIC MAINTENANCE AND TUNE-UP PROCEDURES

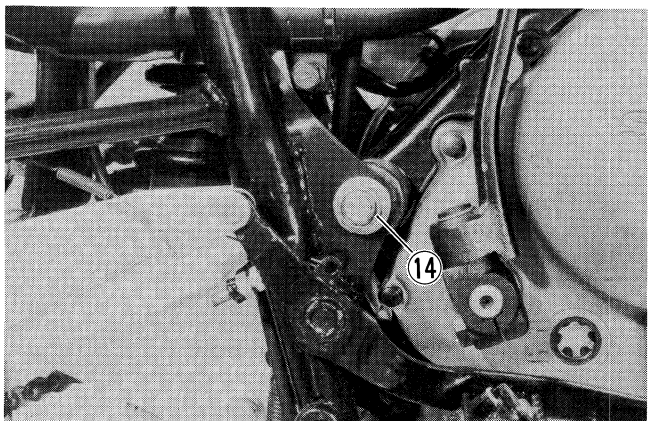
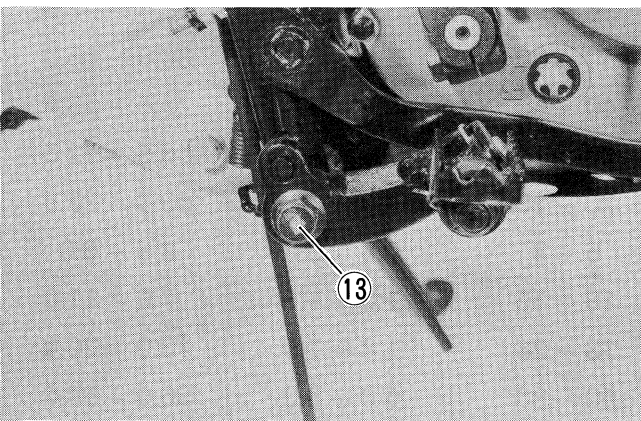
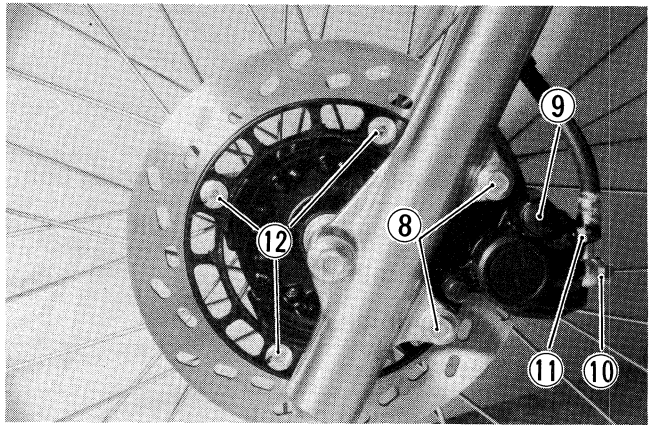
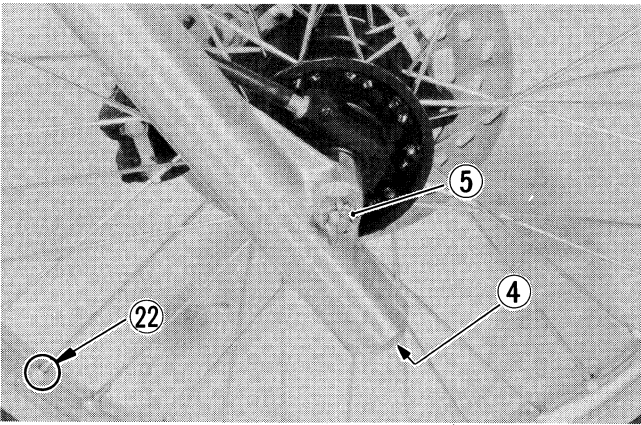
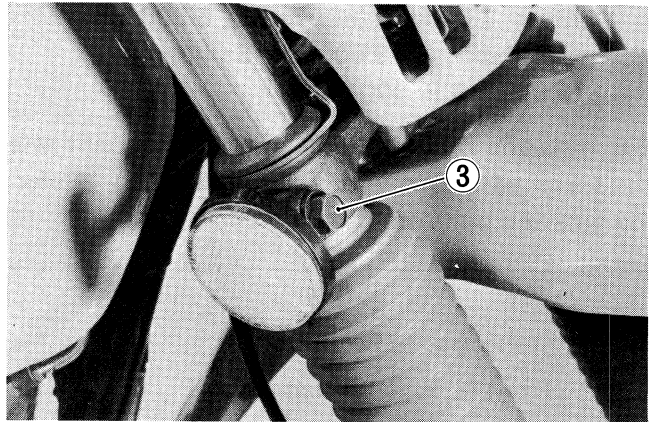
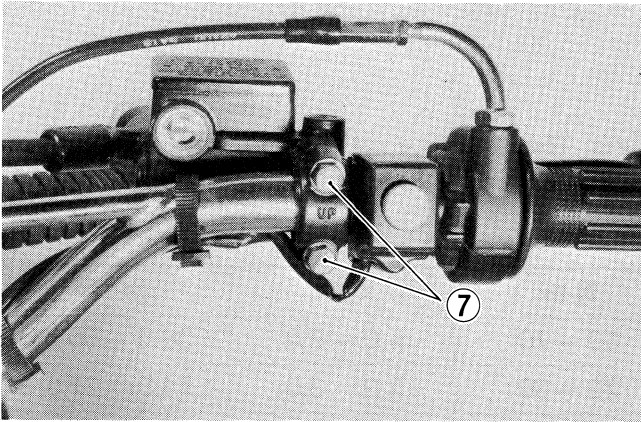
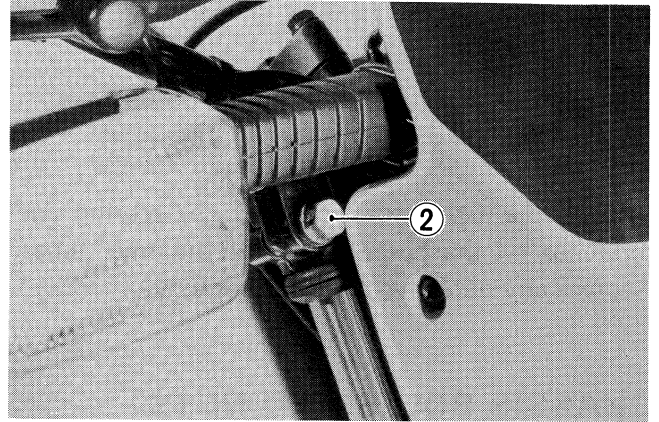
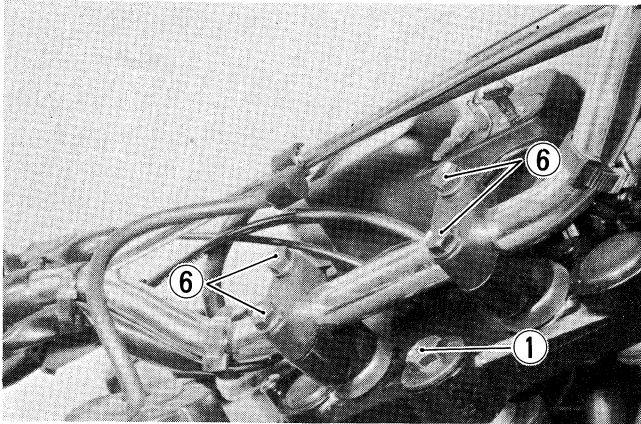

ENGINE REMOUNTING

The engine can be mounted in the reverse order of removal.

- Insert the engine mounting bolts and swingarm pivot shaft from left side. Install the bolts properly as shown in the following illustration.

NOTE:

The engine mounting nuts are self-locking. Once the nut has been removed, it is no longer of any use. Be sure to use new nuts and tighten them to the specified torque.

Tightening torque

Diam.: 8 mm		
Length: 50 mm (A)	37 – 45 N·m	
80 mm (B)	(3.7 – 4.5 kg·m)	
52 mm (D)	27.0 – 32.5 lb-ft)	
70 mm (E)		
Diam.: 8 mm	8 – 12 N·m	
Length: 115 mm (C)	(0.8 – 1.2 kg·m)	
	4.5 – 8.5 lb-ft)	

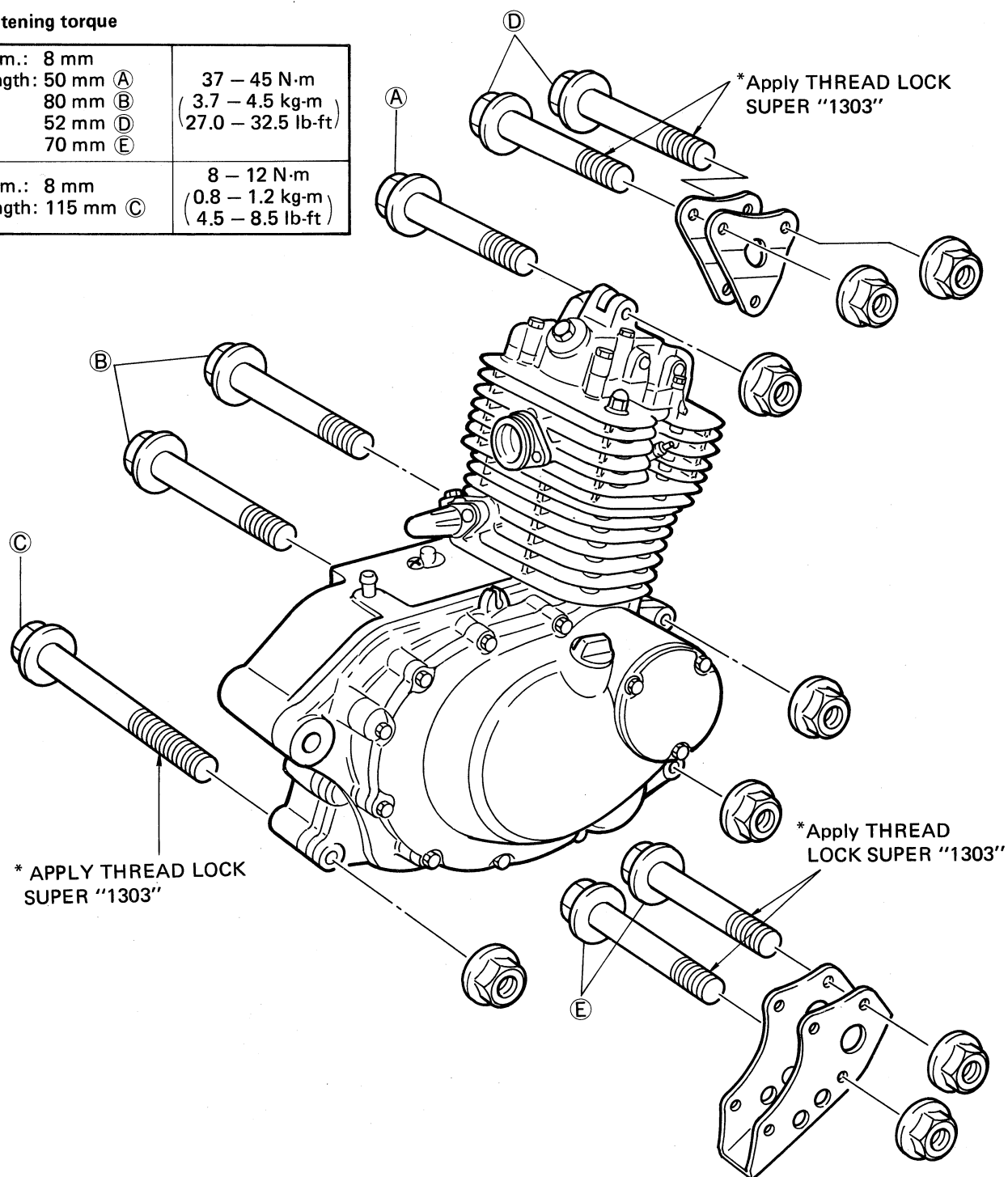

- Remove the crankcase securing bolts.
 - Ⓐ Wire clamp
- Separate the crankcase into 2 parts, right and left with a crankcase separating tool.

09920-13120

Crankcase separating tool

NOTE:

Fit the crankcase separating tool, so that the tool plate is parallel with the end face of the crankcase.

CAUTION:

The crankshaft and transmission components must remain in the left crankcase half. This is necessary because the gearshift cam stopper is mounted on the left crankcase half and will be damaged if the transmission components remain in the right half.

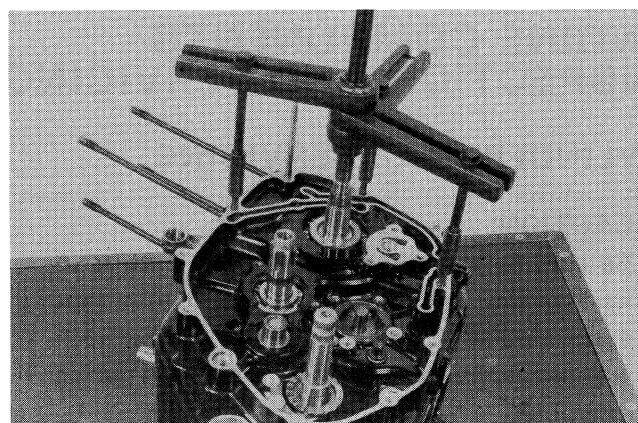
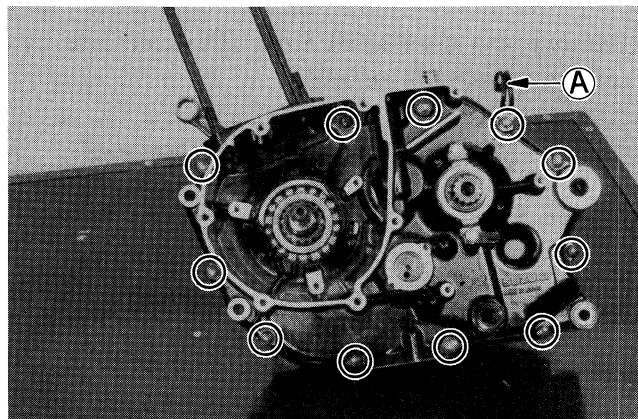

- Remove the gearshift cam stopper spring ①.
- Draw out the gearshift fork shafts ②, and then remove the gearshift forks ③, countershaft assembly ④, driveshaft assembly ⑤ and gearshift cam ⑥.
- Remove the circlip ⑦, spring guide ⑧ and return spring ⑨, and then pull out the kick starter shaft ⑩ from the other side.

09900-06107

Snap ring pliers

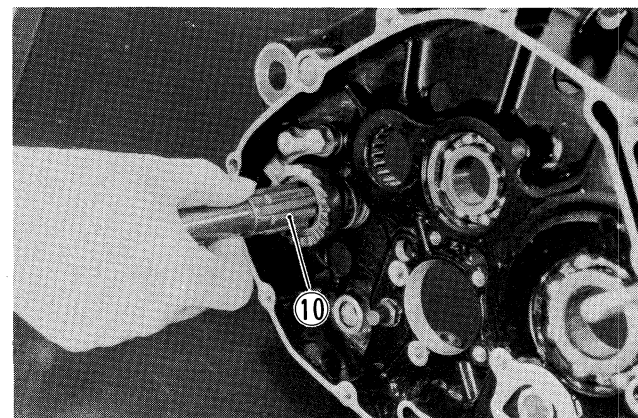
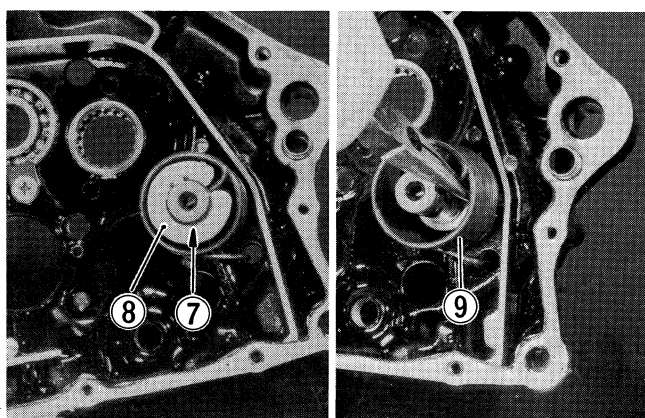
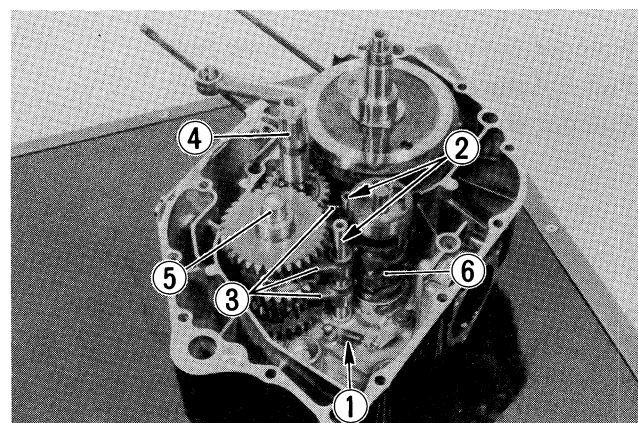

- Install the valve springs, making sure that the close-pitch end ① of each spring goes in first to rest on the head. The coil pitch of both the inner and outer springs vary: the pitch decreases from top to bottom, as shown in the illustration.

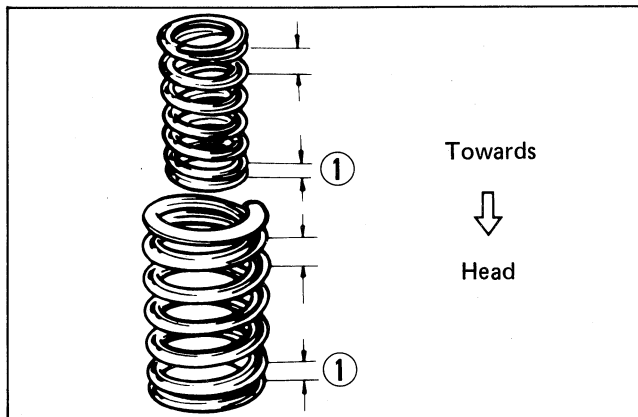

- Fit a valve spring retainer, compress the springs with a valve spring compressor and fit the cotter halves to the stem end.

09916-14510	Valve spring compressor
-------------	-------------------------

09916-84510	Tweezers
-------------	----------

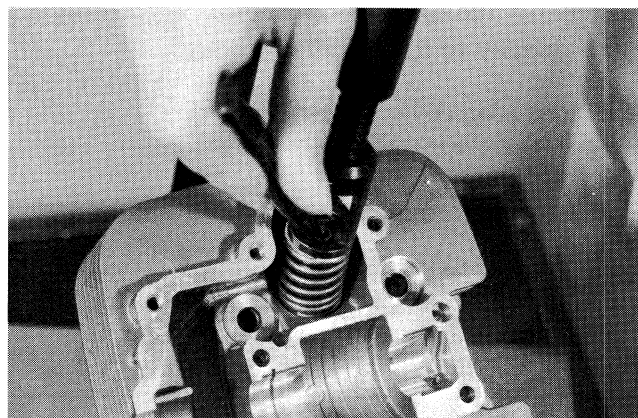

CAMSHAFT

The camshaft should be checked for runout and also for wear of cams and journals if the engine has been noted to produce abnormal noise or vibration or to lack output power. Any of these malconditions could be caused by a worn camshaft.

CAMSHAFT CAM WEAR

Worn-down cams are often the cause of mistimed valve operation resulting in reduced output power. The limit of cam wear is specified for both intake and exhaust cams in terms of cam height H , which is to be measured with a micrometer. Replace camshaft if found it worn down to the limit.

09900-20202	Micrometer (25 – 50 mm)
-------------	----------------------------

Cam height

Height H	Service Limit
Intake cam	33.710 mm (1.3272 in)
Exhaust cam	33.180 mm (1.3063 in)

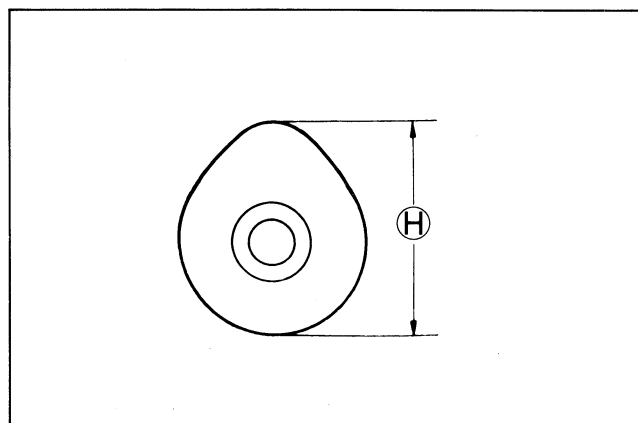
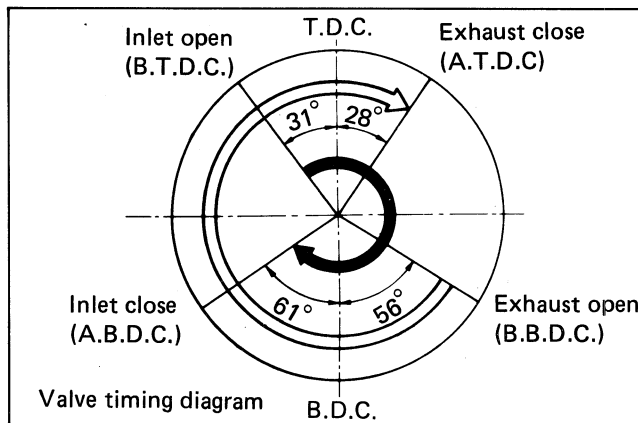

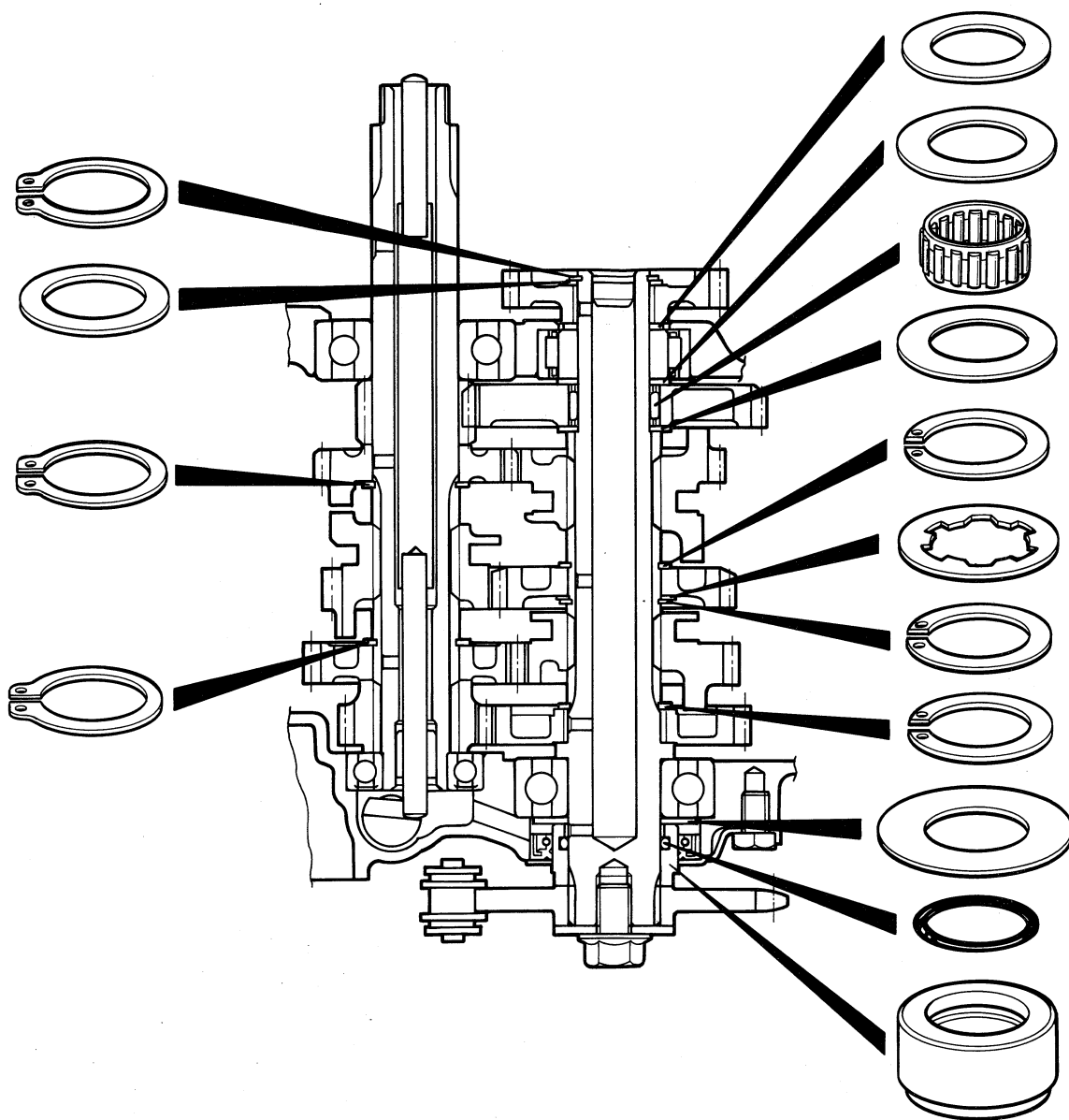

CLUTCH

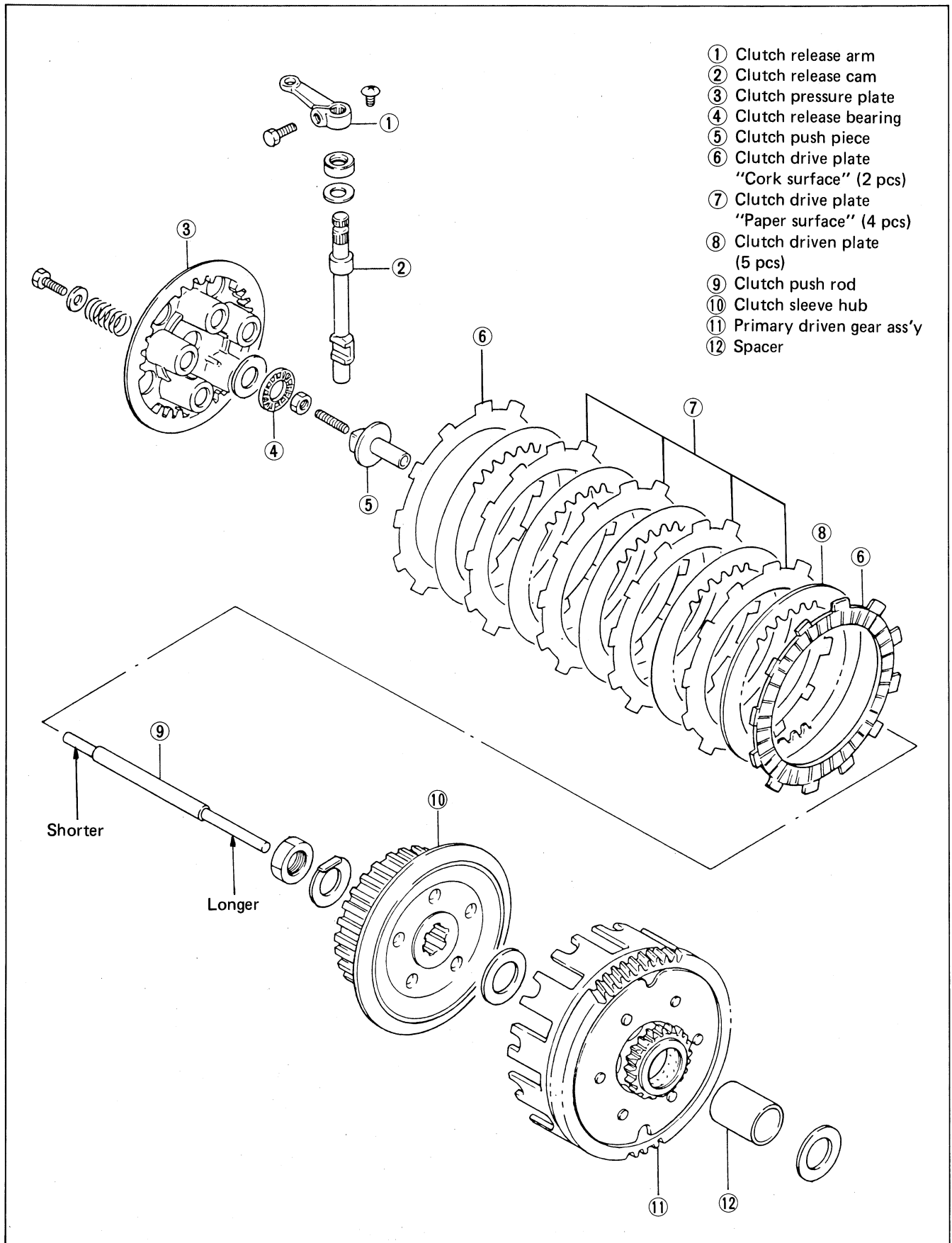

- Bend up the washer tongue positively to lock the bolts.

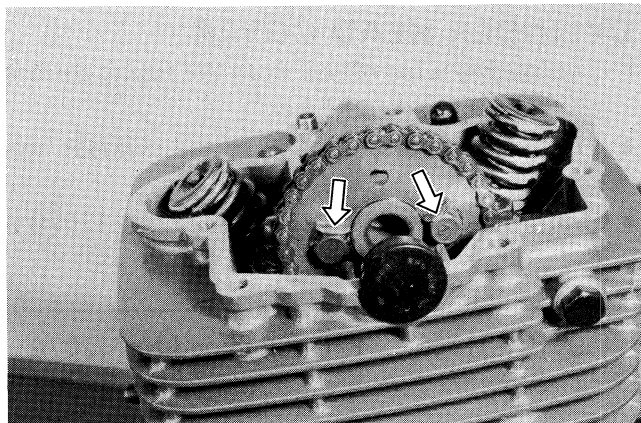

- Apply SUZUKI MOLY PASTE to the camshaft journals.

99000-25140	Suzuki moly paste
-------------	-------------------

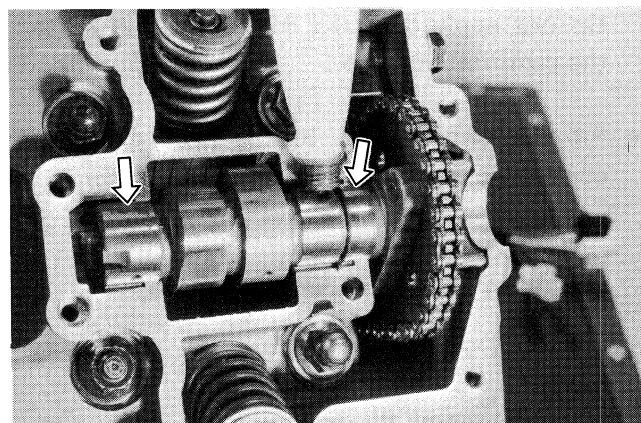

DE-COMPRESSION SHAFT VALVE ROCKER ARM AND SHAFT

- Apply SUZUKI MOLY PASTE to the de-compression shaft and rocker arm shafts.

CAUTION:

- * Use a new O-ring ① on the rocker arm shafts to prevent oil leakage.
- * Use a new gasket ② on the set bolts to prevent oil leakage.

99000-25140	Suzuki moly paste
-------------	-------------------

- After inserting the de-compression shaft and rocker arm shafts, tighten the set bolts ③.

NOTE:

Use a conically recessed top bolt (Set bolt ③) to retain the rocker arm shaft.

Tightening torque (Set bolt ③)	8 – 10 N·m (0.8 – 1.0 kg·m) (6.0 – 7.0 lb·ft)
-----------------------------------	---

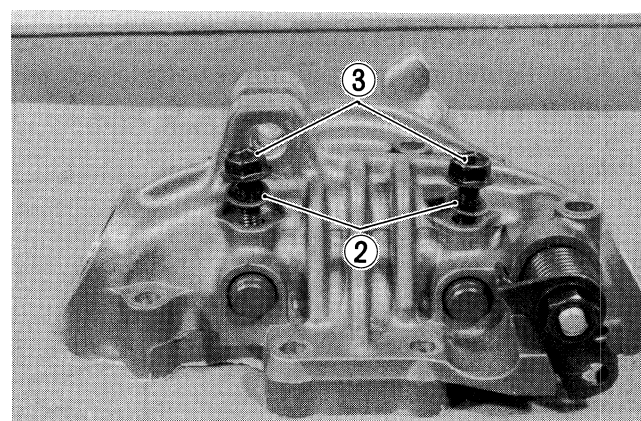
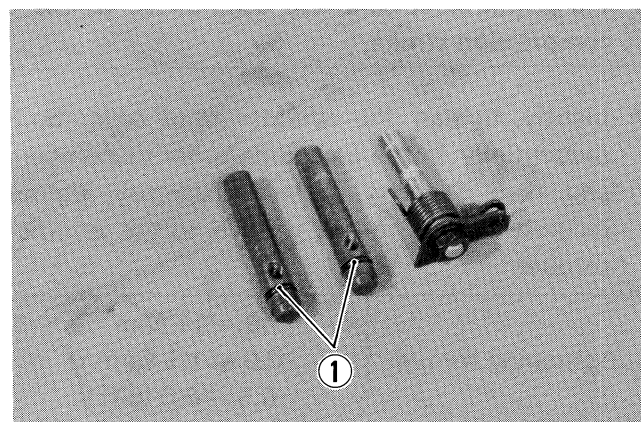

4-7 FUEL AND LUBRICATION SYSTEM

- While turning the throttle valve shaft, place the throttle valve in the groove so that the I.D. number (# 125) ② of the throttle valve faces up-side. Tighten the throttle valve securing screws with applying thread lock "1342."

99000-32050

Thread lock "1342"

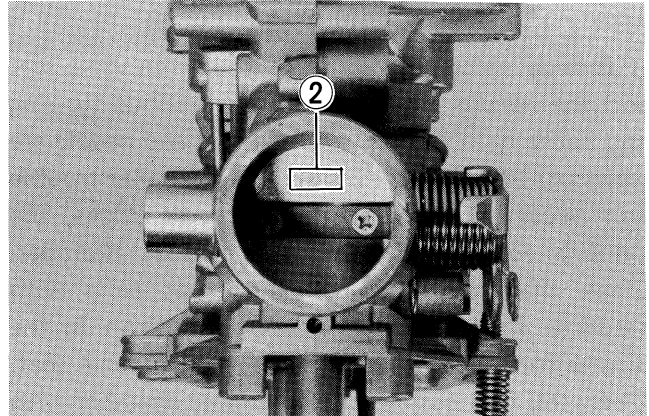

- Set the throttle valve in such a way that its top end ① meets the foremost by-pass ②. This is accomplished by turning throttle valve stop screw.

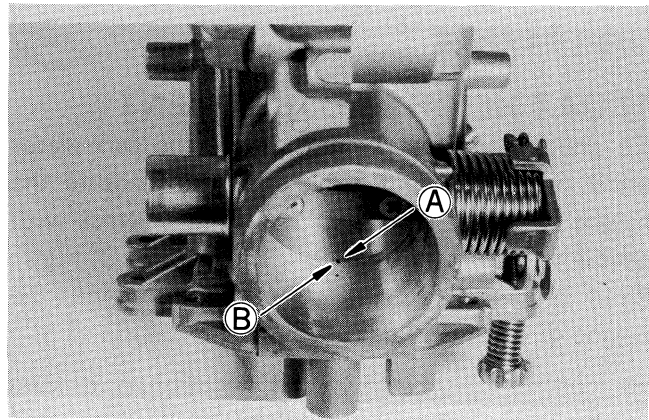

CARBURETOR REMOUNTING

Remount the carburetor by reversing the sequence of removal steps, and following adjustments and inspection are necessary after remounting the carburetor.

- * Throttle cable play (Refer to page 2-11)
- * Idling adjustment (Refer to page 2-10)

INSPECTION

MAGNETO COIL

- Remove the left and right frame covers and seat. (Refer to page 3-3)
- Disconnect the pick-up, power source and charging lead wires.
- Using the pocket tester, measure the resistance between the lead wires in the following table.

09900-25002	Pocket tester
-------------	---------------

Magneto coil resistance	
Pick-up	BI/Y – G/W 94 – 140 Ω (Range: x 100 Ω)
Power source	Br – P 97 – 146 Ω (Range: x 100 Ω)
Charging	Y – Y 0.1 – 1.0 Ω (Range: x 1 Ω)



WIRE COLOR

BI/Y : Blue with Yellow tracer
 G/W : Green with White tracer
 Br : Brown
 P : Pink
 Y : Yellow

CAUTION:

When replacing the magneto coils, apply a small quantity of **THREAD LOCK "1342"** to the threaded parts of screws.

99000-32050	Thread Lock "1342"
-------------	--------------------

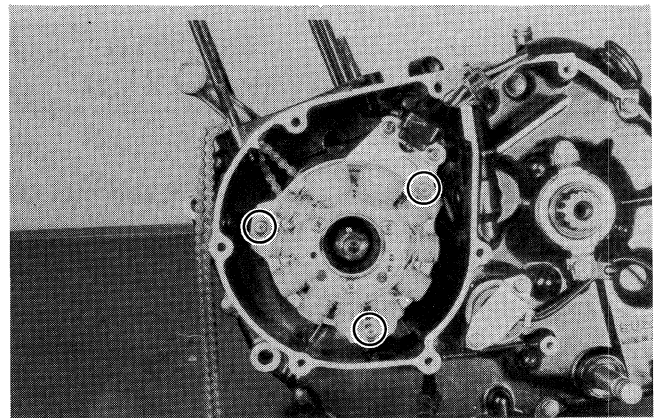

CAUTION:

Bond No. 1207B should be applied to the groove of magneto lead wire grommet.

99104-31140	Suzuki Bond No. 1207B
-------------	-----------------------

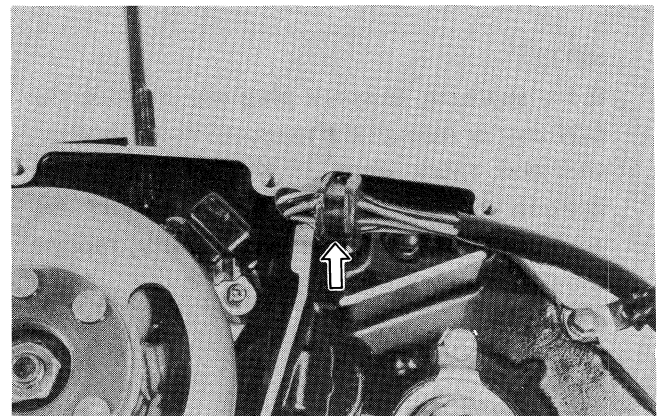

CLICK HERE TO **DOWNLOAD** THE COMPLETE MANUAL

- Thank you very much for reading the preview of the manual.
- You can download the complete manual from: www.heydownloads.com by clicking the link below



- Please note: If there is no response to CLICKING the link, please download this PDF first and then click on it.

CLICK HERE TO **DOWNLOAD** THE COMPLETE MANUAL

Charge battery with current as described in the tables shown below.

Maximum charging current	1.4A
--------------------------	------

Charging time

The charging time for a new battery is determined by the number of months that have elapsed since the date of manufacture.

Confirmation for date of manufacture

Date of manufacture is indicated by a three-part number ①, as shown in the photograph, each indicating month, date and year.

Near the end of charging period, adjust the specific gravity of electrolyte to value specified. After charging, adjust the electrolyte level to the MAX. LEVEL with DISTILLED WATER.

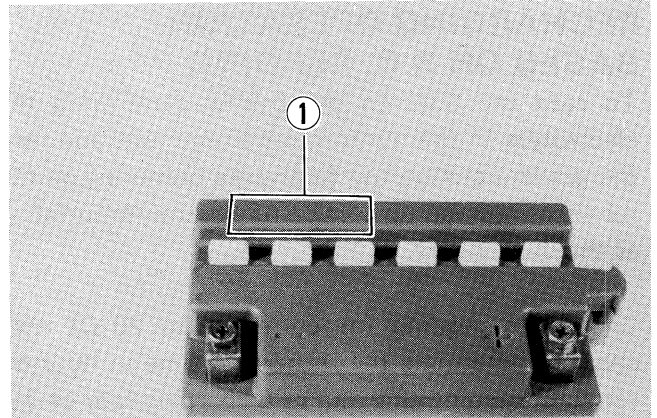

Months after manufacturing	Within 6	Within 9	Within 12	Over 12
Necessary charging hours	20	30	40	60

SERVICING

Visually inspect the surface of the battery container. If any signs of cracking or electrolyte leakage from the sides of the battery have occurred, replace the battery with a new one.

If the battery terminals are found to be coated with rust or an acidic white powdery substance, then this can be cleaned away with sandpaper.

Check the electrolyte level and add distilled water, as necessary to raise the electrolyte to each cell's MAX. level.

Check the battery for proper charge by taking an electrolyte S.G. reading. If the reading is 1.22 or less, as corrected to 20°C (68°F), it means that the battery is still in a run-down condition and needs recharging.

NOTE:

First, remove the ⊖ lead wire.

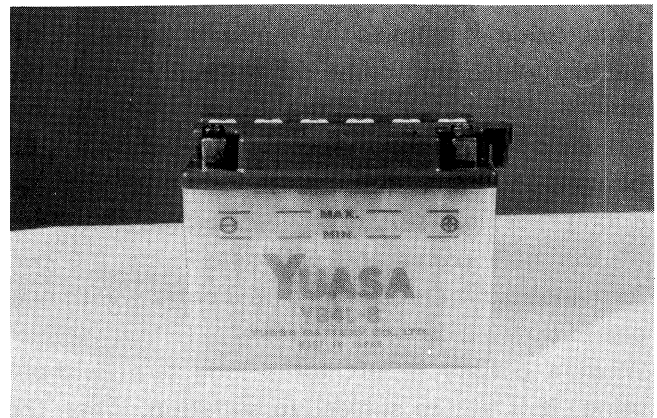

Check the disc for wear by using a micrometer. Its thickness can be checked with disc and wheel in place. Replace the disc if the thickness exceeds the service limit.

09900-20205	Micrometer (0 – 25 mm)
Service Limit	3.0 mm (0.12 in)

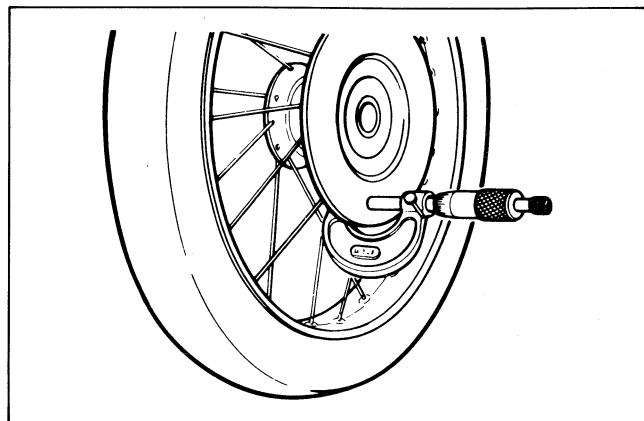

With the disc mounted on the wheel, check the disc for face runout with a dial gauge, as shown. Replace the disc if the runout exceeds the service limit.

09900-20606	Dial gauge (1/100 mm)
09900-20701	Magnetic stand Not available in U.S.A.
Service Limit	0.30 mm (0.012 in)

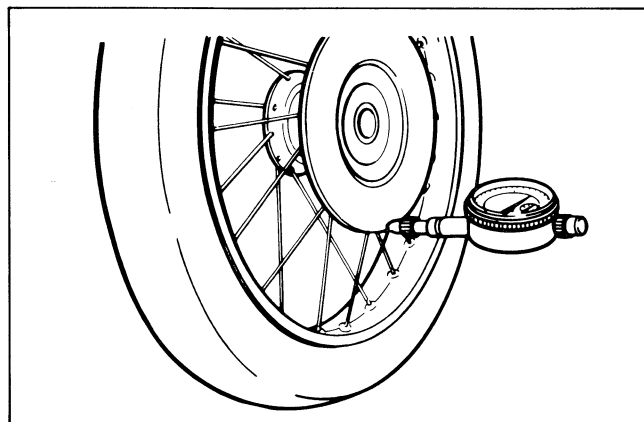

DISC SERVICING

- Take off the front wheel. (Refer to page 7-1)
- Remove the disc mounting bolts and separate the disc from the wheel hub.
- Make sure that the brake disc is clean and free of any greasy matter. Apply thread lock "1360" to the disc mounting bolts and tighten them to the specified torque.

99000-32130	Thread lock "1360"
Tightening torque	18 – 28 N·m (1.8 – 2.8 kg-m) (13.0 – 20.0 lb-ft)

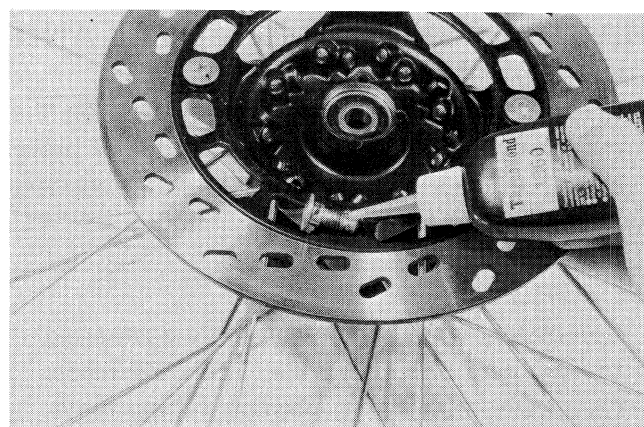

STOPPER RING

- Install a new stopper ring into the ring groove.

CAUTION:

- * Always use a new stopper ring.
- * After installing a stopper ring, always insure that it is completely seated in its groove and securely fitted.

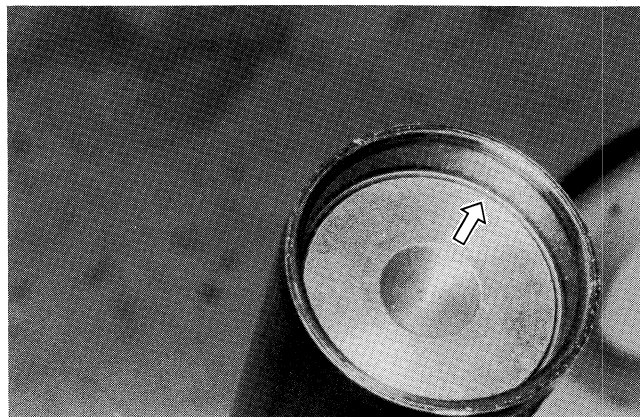

FRONT FORK REMOUNTING

- When installing the front fork assembly, align the top surface ① of the inner tube to the top surface ② of the steering stem upper bracket.

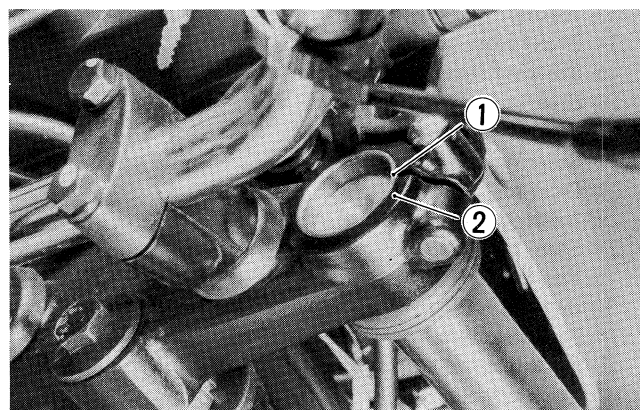

SPOKE NIPPLE

Check to be sure that all nipples are tight, and retighten them as necessary using special tool.

Tightening torque	4 – 5 N·m (0.4 – 0.5 kg-m) (3.0 – 3.5 lb-ft)
-------------------	--

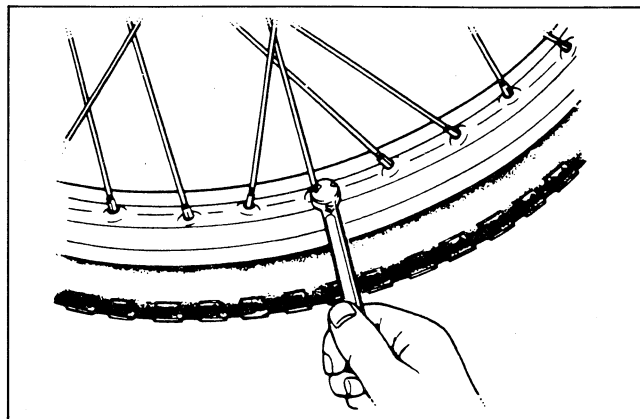

REAR SPROCKET

Inspect the sprocket teeth for wear. If they are worn as illustrated, replace the sprocket and drive chain.

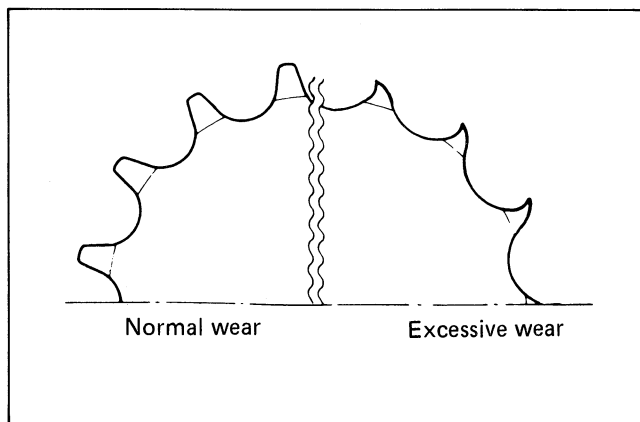

BRAKE DRUM

Measure the brake drum I.D. to determine the extent of wear. If the limit is exceeded by the wear noted, replace the drum. The value of this limit is indicated inside the drum.

Service Limit	130.7 mm (5.15 in)
---------------	--------------------

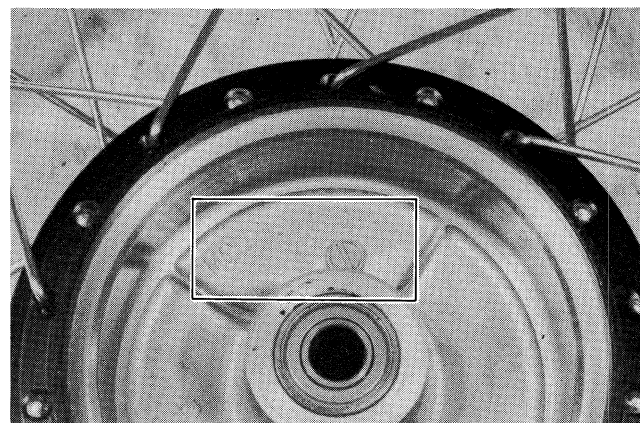

BRAKE SHOE

Check the brake shoes and decide whether they should be replaced or not from the thickness of the brake shoe linings.

Service Limit	1.5 mm (0.06 in)
---------------	------------------

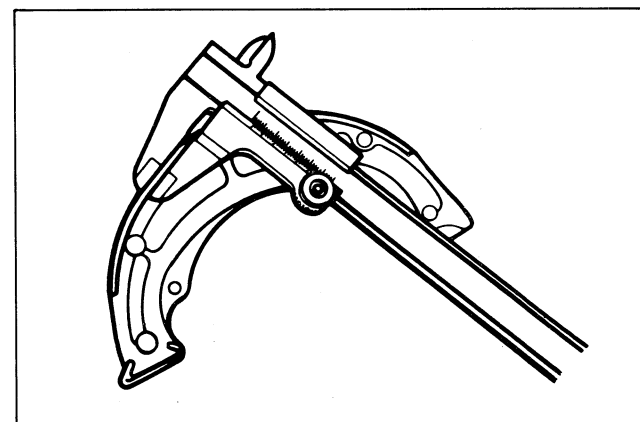

CAUTION:
 Replace the brake shoes as a set, otherwise braking performance will be adversely affected.

REASSEMBLY AND REMOUNTING

Reassemble and remount the rear suspension in the reverse order of disassembly and removal. Pay attention to the following points:

SHOCK ABSORBER

- Apply grease to the spherical ball bearings and dust seals before installing.

99000-25030	Suzuki super grease "A"
-------------	-------------------------

(Refer to page 7-40 for details)

- Install the upper and lower spherical ball bearings by using an appropriate socket wrench.
- Install new stopper rings into the ring groove.

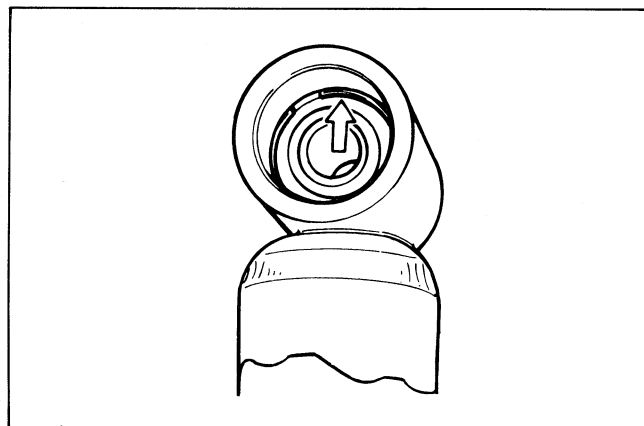
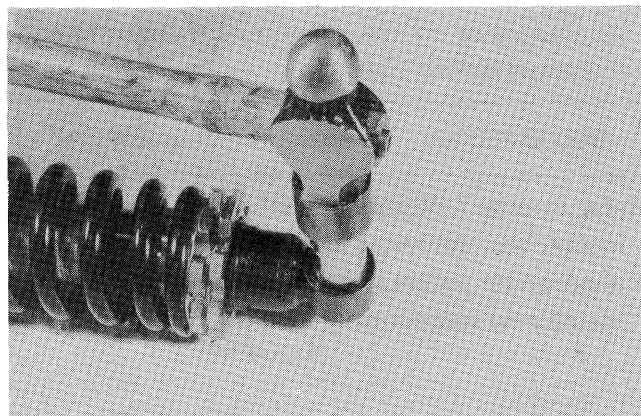

CUSHION LEVER

- Install the cushion lever center bearing by using the hydraulic press and bearing installer.

09913-76010	Bearing installer Not available in U.S.A.
-------------	--

NOTE:

Install the center bearing at 7 mm depth from the cushion lever hole surface.

- Apply grease to the bearing, spacer and dust seals. (Refer to page 7-40 for details)

99000-25030	Suzuki super grease "A"
-------------	-------------------------

NOTE:

Install the dust seals at 2 mm depth from the cushion lever hole surface.

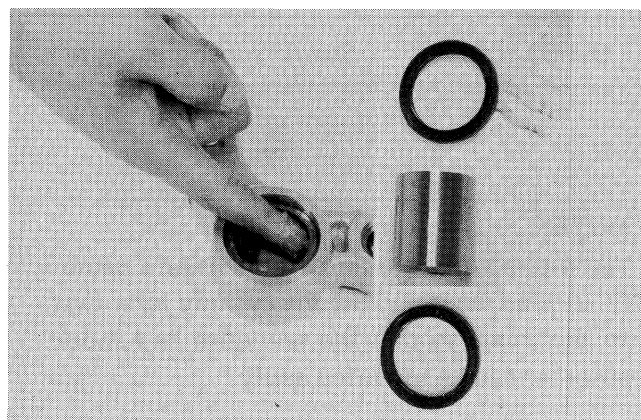

CHASSIS

Complaint	Symptom and possible causes	Remedy
Heavy steering.	<ol style="list-style-type: none"> 1. Steering stem nut overtightened. 2. Broken bearing in steering stem. 3. Distorted steering stem. 4. No enough pressure in tires. 	Adjust. Replace. Replace. Adjust.
Wobbly handle.	<ol style="list-style-type: none"> 1. Loss of balance between right and left front forks. 2. Distorted front fork. 3. Distorted front axle or crooked tire. 	Replace. Repair or replace. Replace.
Wobbly front wheel.	<ol style="list-style-type: none"> 1. Distorted wheel rim. 2. Worn-down front wheel bearings. 3. Defective or incorrect tire. 4. Loose nut on axle. 5. Incorrect front fork oil level. 	Replace. Replace. Replace. Retighten. Adjust.
Front suspension too soft.	<ol style="list-style-type: none"> 1. Weakened springs. 2. Not enough fork oil. 	Replace. Refill.
Front suspension too stiff.	<ol style="list-style-type: none"> 1. Fork oil too viscous. 2. Too much fork oil. 3. Distorted front fork inner tube. 	Replace. Drain excess oil. Replace.
Noisy front suspension.	<ol style="list-style-type: none"> 1. Not enough fork oil. 2. Loose bolts or nuts on suspension. 	Refill. Retighten.
Wobbly rear wheel.	<ol style="list-style-type: none"> 1. Distorted wheel rim. 2. Worn-down rear wheel bearings or swingarm bushings. 3. Defective or incorrect tire. 4. Worn swingarm and rear cushion related bearings. 5. Loose nuts or bolts on rear suspension. 6. Loosen nut on axle. 	Replace. Replace. Replace. Replace. Retighten. Retighten.
Rear suspension too soft.	<ol style="list-style-type: none"> 1. Weakened shock absorber spring. 2. Shock absorber spring length improperly set. 3. Oil leakage of shock absorber. 	Replace. Adjust. Replace.
Rear suspension too stiff.	<ol style="list-style-type: none"> 1. Shock absorber spring length improperly set. 2. Shock absorber shaft bent. 3. Swingarm bent. 4. Worn swingarm and rear cushion related bearings. 	Adjust. Replace. Replace. Replace.
Noisy rear suspension.	<ol style="list-style-type: none"> 1. Loose nuts or bolts on rear suspension. 2. Worn swingarm and rear cushion related bearings. 	Retighten. Replace.

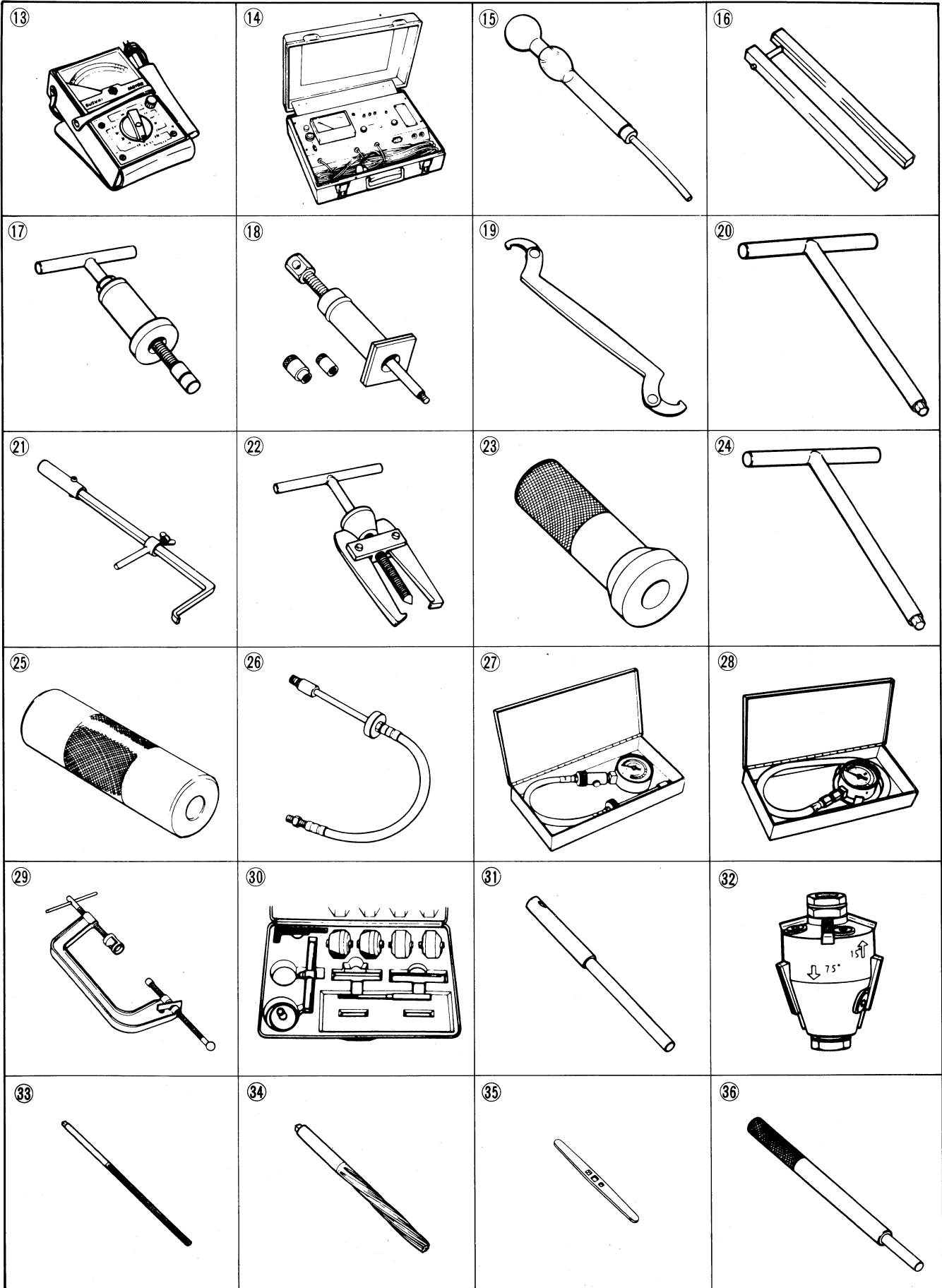

WATTAGE

Unit: W

ITEM		SPECIFICATION
Headlight	HI	45
	LO	45
Tail/Brake light		8/23
Turn signal light		23
Speedometer light		3.4
Turn signal indicator light		3.4
High beam indicator light		1.7
Neutral indicator light		3.4
Side stand check light		3.4

BRAKE + WHEEL

Unit: mm (in)

ITEM	STANDARD		LIMIT
Master cylinder bore	12.700 – 12.743 (0.4999 – 0.5017)		—
Master cylinder piston diam.	12.657 – 12.684 (0.4983 – 0.4994)		—
Brake caliper cylinder bore	33.960 – 34.036 (1.3370 – 1.3400)		—
Brake caliper piston diam.	33.884 – 33.934 (1.3340 – 1.3360)		—
Brake disc thickness	3.3 – 3.7 (0.13 – 0.15)		3.0 (0.12)
Brake disc runout	—		0.3 (0.01)
Rear brake pedal free travel	20 – 30 (0.8 – 1.2)		—
Rear brake pedal height	10 (0.4)		—
Brake drum I.D.	—		130.7 (5.15)
Brake lining thickness	—		1.5 (0.06)
Wheel rim runout	Axial	—	2.0 (0.08)
	Radial	—	2.0 (0.08)
Wheel axle runout	Front	—	0.25 (0.010)
	Rear	—	0.25 (0.010)
Tire size	Front	80/80 – 21 45P	—
	Rear	110/80 – 18 58P	—
Tire tread depth	Front	—	3.0 (0.12)
	Rear	—	3.0 (0.12)

ITEM	STANDARD		LIMIT
Shift fork to groove clearance	0.10–0.30 (0.004–0.012)		0.50 (0.020)
Shift fork groove width	No.1, No.2 & No.3	5.00–5.10 (0.197–0.201)	—
Shift fork thickness	No.1, No.2 & No.3	4.80–4.90 (0.189–0.193)	—
Drive chain	Type	D.I.D.: 520VC. 6 TAKASAGO: RK520MO-Z2	—
	Links	112	—
	20-pitch length	—	319.4 (12.57)
Drive chain slack	25–35 (1.0–1.4)		—

CARBURETOR

ITEM	SPECIFICATION
Carburetor type	*MIKUNI TM28SS
Bore size	*28 mm (1.1 in)
I.D. No.	*42A20
Idle r/min.	1 450 ± 50 r/min.
Float height	*14.2 ± 1.0 mm (0.56 ± 0.04 in)
Main jet (M.J.)	*# 115
Main air jet (M.A.J.)	0.6 mm
Jet needle (J.N.)	*5FP85-3rd
Needle jet (N.J.)	*P-6
Cut-away (C.A.)	*1.5
Pilot jet (P.J.)	*# 25
Pilot air jet (P.A.J.)	*0.9 mm
By-pass (B.P.)	*0.8 mm
Pilot outlet (P.O.)	*0.6 mm
Starter jet (G.S.)	*#37.5
Pilot screw (P.S.)	* 5/8 turn out
Throttle cable play	0.5–1.0 mm (0.02–0.04 in)

ELECTRICAL

Unit: mm (in)

ITEM	SPECIFICATION		NOTE
Ignition timing	7° B.T.D.C. Below 1 950 r/min. and 37° B.T.D.C. Above 3 800 r/min.		
Spark plug	Type	NGK: D8EA N.D.: X24ES-U	
	Gap	0.6–0.7 (0.024–0.028)	
Spark performance	Over 8 (0.3) at 1 atm.		
Ignition coil resistance	Primary	0–0.5 Ω	⊕ tap– ⊖ tap
	Secondary	13–15 kΩ	Plug cap– ⊕ tap

Specifications marked with asterisks (*) are exclusive to DR200G.

- Remove the float chamber body by removing the four screws.

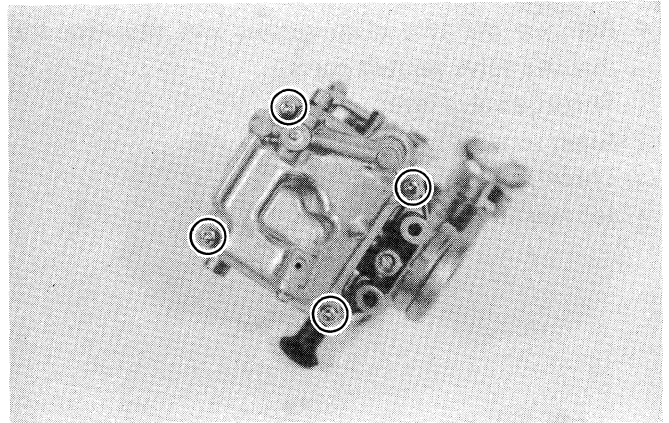

- Pull out the float pin and remove the float.

CAUTION:

When removing the float pin, be careful not to damage the carburetor body.

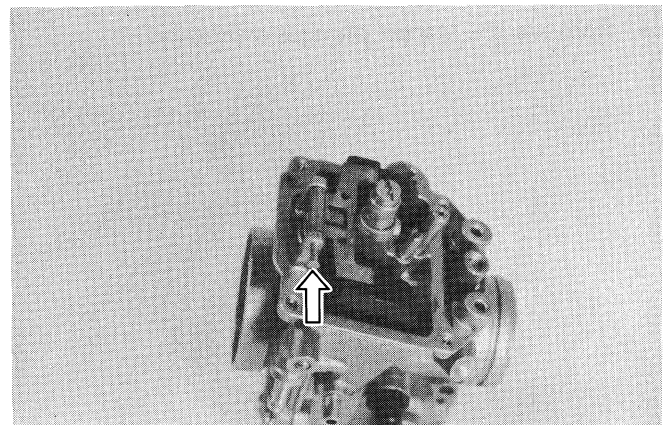

- Remove the needle valve ①, main jet ② (needle jet), pilot jet ③ and pilot screw ④.
- Remove the needle jet from the bore side.

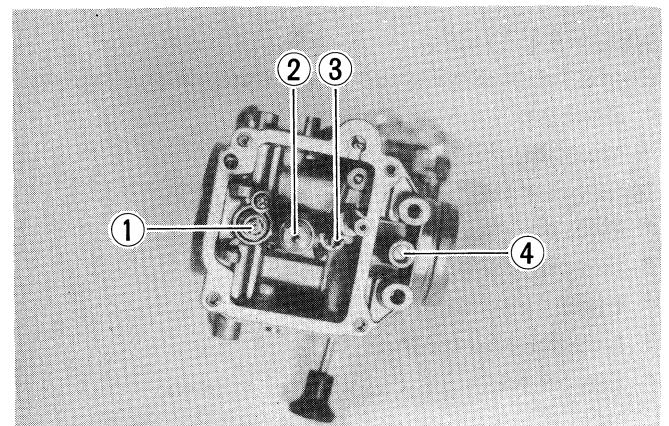

- Remove the accelerating plunger and spring from the float chamber body.

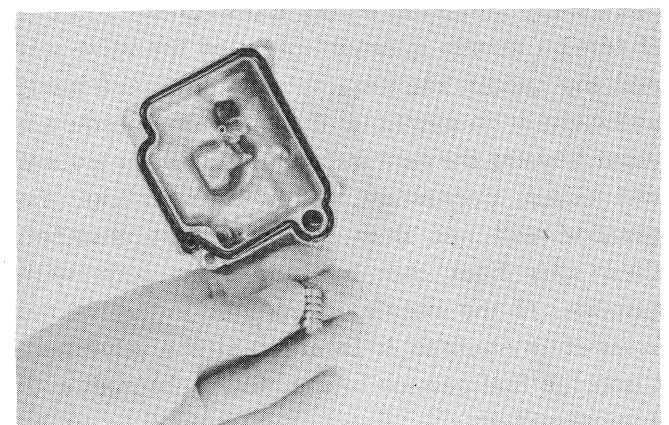

HOSE ROUTING

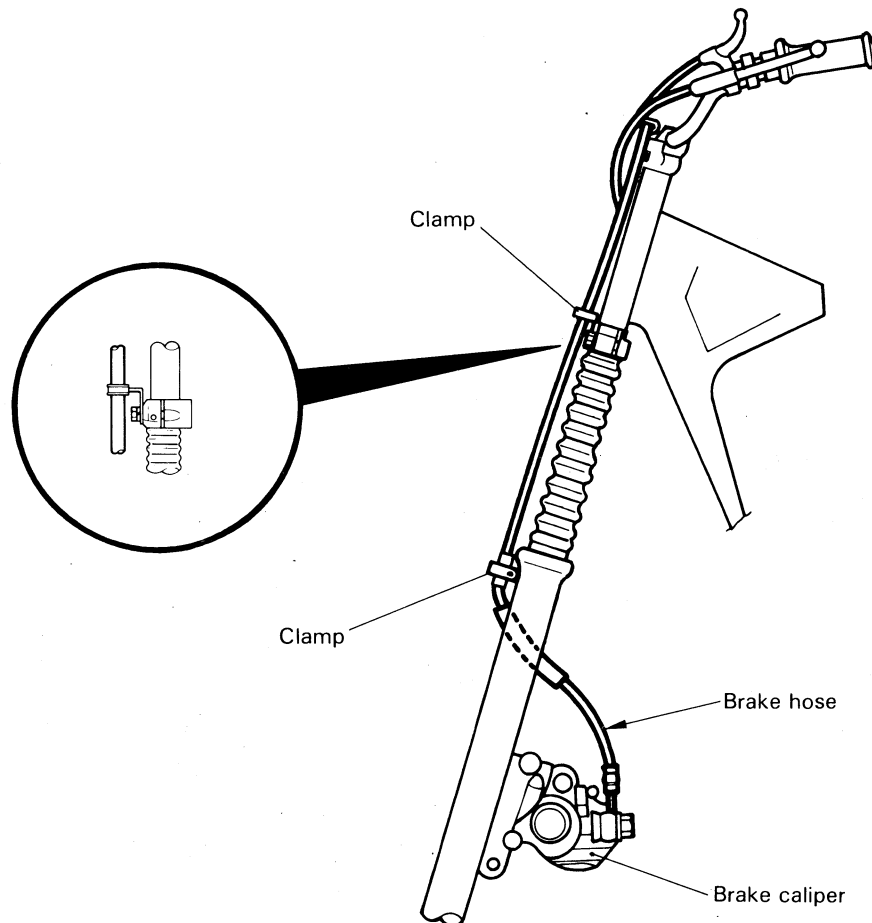
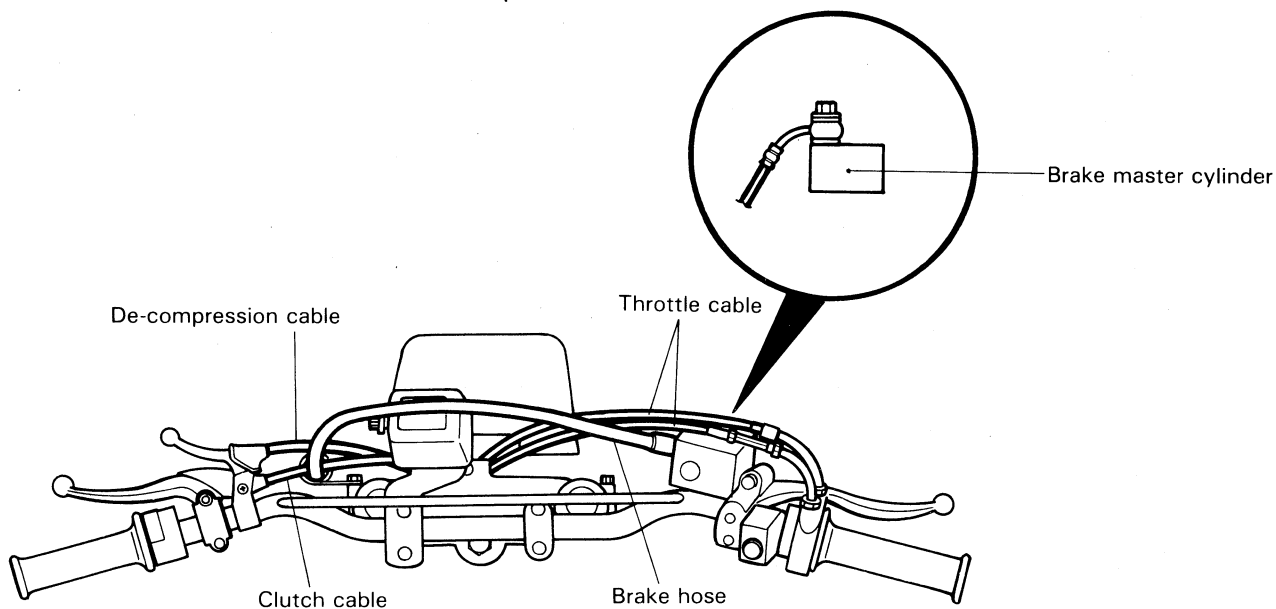

ITEM	STANDARD		LIMIT
Camshaft journal holder I.D.	22.012–22.025 (0.8666–0.8671)		—
Camshaft journal O.D.	21.959–21.980 (0.8645–0.8654)		—
Cam chain 20-pitch length	—		129.0 (5.08)
Rocker arm I.D.	IN. & EX.	12.000–12.018 (0.4724–0.4731)	—
Rocker arm shaft O.D.	IN. & EX.	11.977–11.995 (0.4715–0.4722)	—
Cylinder head distortion	—		0.05 (0.002)
Cylinder head cover distortion	—		0.05 (0.002)

CYLINDER + PISTON + PISTON RING

Unit: mm (in)

ITEM	STANDARD		LIMIT
Compression pressure	1 100–1 500 kPa (11–15 kg/cm ²) (156–213 psi)		900 kPa (9 kg/cm ²) (128 psi)
Piston to cylinder clearance	0.040–0.050 (0.0015–0.0019)		0.120 (0.0047)
Cylinder bore	66.000–66.015 (2.5984–2.5990)		66.090 (2.6020)
Piston diam.	65.955–65.970 (2.5966–2.5972) Measure at 15 (0.59) from the skirt end.		65.880 (2.5937)
Cylinder distortion	—		0.05 (0.002)
Piston ring free end gap	1st	R Approx. 7.5 (0.30)	6.0 (0.24)
	2nd	R Approx. 9.4 (0.37)	7.5 (0.30)
Piston ring end gap	1st & 2nd	0.10–0.25 (0.004–0.010)	0.70 (0.028)
Piston ring to groove clearance	1st	—	0.180 (0.0071)
	2nd	—	0.150 (0.0059)
Piston ring groove width	1st	1.01–1.03 (0.039–0.040)	—
	2nd	1.21–1.23 (0.047–0.048)	—
	Oil	2.01–2.03 (0.079–0.080)	—
Piston ring thickness	1st	0.97–0.99 (0.038–0.039)	—
	2nd	1.17–1.19 (0.046–0.047)	—
Piston pin bore	16.002–16.008 (0.6299–0.6302)		16.030 (0.6311)

ITEM	STANDARD		LIMIT
Shift fork to groove clearance	0.10–0.30 (0.004–0.012)		0.50 (0.020)
Shift fork groove width	No.1, No.2 & No.3	5.00–5.10 (0.197–0.201)	—
Shift fork thickness	No.1, No.2 & No.3	4.80–4.90 (0.189–0.193)	—
Drive chain	Type	D.I.D.: 520VC. 6 TAKASAGO: RK520MO-Z2	
	Links	112	
	20-pitch length	—	319.4 (12.57)
Drive chain slack	25–35 (1.0–1.4)		—

CARBURETOR

ITEM	SPECIFICATION
Carburetor type	MIKUNI TM28SS
Bore size	28 mm (1.1 in)
I.D. No.	42A20
Idle r/min.	1 450 ± 50 r/min.
Float height	14.2 ± 1.0 mm (0.56 ± 0.04 in)
Main jet (M.J.)	# 115
Main air jet (M.A.J.)	0.6 mm
Jet needle (J.N.)	5FP85-3rd
Needle jet (N.J.)	P-6
Cut-away (C.A.)	1.5
Pilot jet (P.J.)	# 25
Pilot air jet (P.A.J.)	0.9 mm
By-pass (B.P.)	0.8 mm
Pilot outlet (P.O.)	0.6 mm
Starter jet (G.S.)	#37.5
Pilot screw (P.S.)	⁵ / ₈ turn out
Throttle cable play	0.5–1.0 mm (0.02–0.04 in)

ELECTRICAL

Unit: mm (in)

ITEM	SPECIFICATION		NOTE
Ignition timing	7° B.T.D.C. Below 1 950 r/min. and 37° B.T.D.C. Above 3 800 r/min.		
Spark plug	Type	NGK: D8EA N.D.: X24ES-U	
	Gap	0.6–0.7 (0.024–0.028)	
Spark performance	Over 8 (0.3) at 1 atm.		
Ignition coil resistance	Primary	0–0.5 Ω	⊕ tap – ⊖ tap
	Secondary	13–15 kΩ	Plug cap – ⊕ tap

CLICK HERE TO **DOWNLOAD** THE COMPLETE MANUAL

- Thank you very much for reading the preview of the manual.
- You can download the complete manual from: www.heydownloads.com by clicking the link below



- Please note: If there is no response to CLICKING the link, please download this PDF first and then click on it.

CLICK HERE TO **DOWNLOAD** THE COMPLETE MANUAL