

■ SAFETY RULES FOR LIFT TRUCK OPERATORS

◆ General

The safety rules and regulations in this section are representative of some, but not all rules and regulations that apply to lift trucks. Rules are paraphrased without representation that they have been reproduced verbatim.

All lift truck users should be familiar with their Local, Regional, and National regulations. Operate this lift truck in accordance with local regulations.

The most effective way of reducing the risk of serious injuries, or even death, to you and others, is for you to know how to operate the lift truck properly. Drive alertly and avoid maneuvers or conditions that could cause accidents.

Be professional.

Do not operate your lift truck if it is in need of maintenance, repair or appears to be unsafe in any way. Report all unsafe conditions immediately to your supervisor, then contact your authorized Cat lift truck dealer.

Do not attempt any adjustments or repairs unless you are trained and authorized to do so.

Continuing improvement and advancement of product design may have caused changes to your lift truck, which are not included in this publication. Whenever a question arises regarding your lift truck, or this publication, please contact your authorized Cat lift truck dealer for the latest available information.

All lift truck users should be familiar with their Local, Regional, and National regulations.

CLICK HERE TO **DOWNLOAD** THE COMPLETE MANUAL

- Thank you very much for reading the preview of the manual.
- You can download the complete manual from: www.heydownloads.com by clicking the link below



- Please note: If there is no response to CLICKING the link, please download this PDF first and then click on it.

CLICK HERE TO **DOWNLOAD** THE COMPLETE MANUAL

► Mast Vertical Switch (Optional)

When the mast is placed at a tilt-back position without load, push the tilt lever forward while pressing the switch. The mast stops at a vertical position.

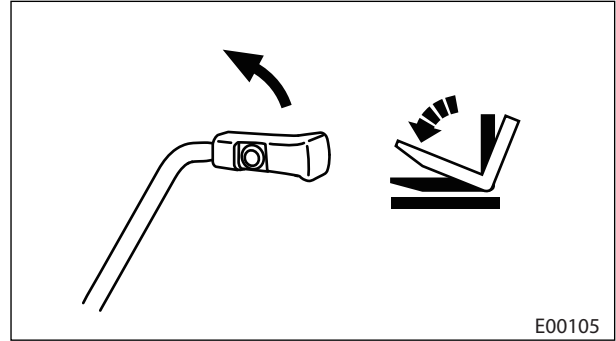

► Attachment Lever (Optional)

The mast interlock will not work for the attachment levers. Therefore, when the attachment lever is operated, some of the attachments will move, even though the engine is not running or the key switch is in the OFF position, as a result of the handling load or of its own weight.

► To Remove Wheel

(1) Loosen the wheel nuts about two rotations.

Note: Only loosen the wheel nuts. Do not remove them.

(2) Position the jack under the lift truck at the specified jacking point.

Note: For jacking point, see 10-4 "To Raise Front Wheel" and 10-5 "To Raise Rear Wheel".

(3) Raise the lift truck by operating the jack until the tire just clears the ground.

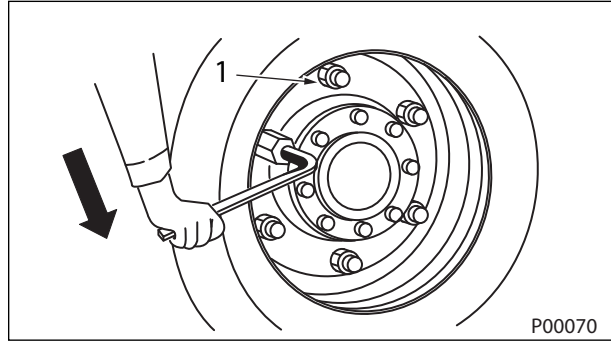

1. Wheel nut

(4) Remove the wheel nuts (loosened in Step 1).

(5) Firmly hold the wheel with both hands and remove it from the lift truck.

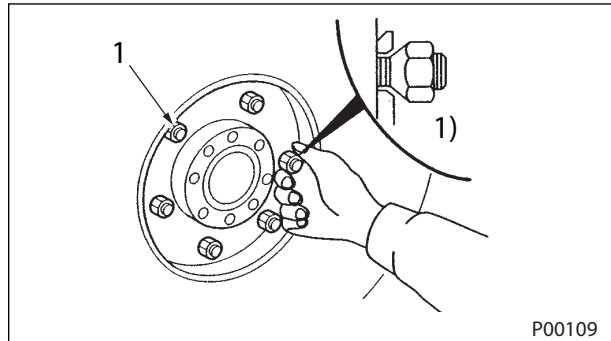

1. Wheel nut

1) Countersink

⚠ WARNING

DO NOT loosen rim bolts.

⚠ CAUTION

Be careful NOT to strip the bolt threads when removing the wheel.

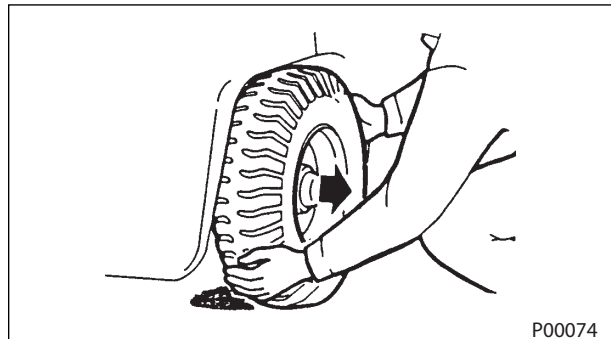

P00074

MAINTENANCE

- (1) Remove the filler cap.

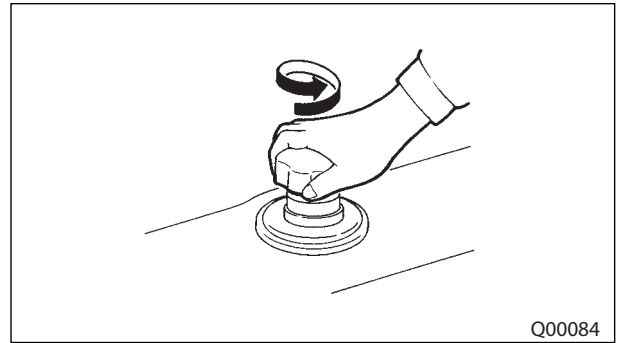

- (2) Remove the hydraulic tank drain plug. Allow the oil to drain. Clean and install the drain plug.
- (3) Fill the hydraulic tank. See 12-11 "Refill Capacities". Put the filler cap back on.
- (4) Start the engine and operate the hydraulic controls and the steering system through a few cycles to fill the filters and lines.
- (5) Retract all hydraulic cylinders and stop the engine.

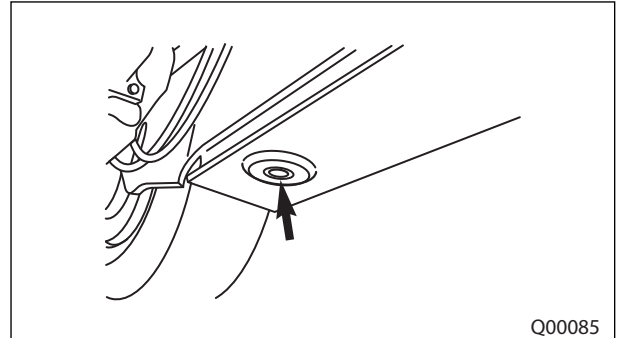

- (6) Remove the filler cap and the dip stick. Keep the oil level at the HIGH mark on the dip stick.

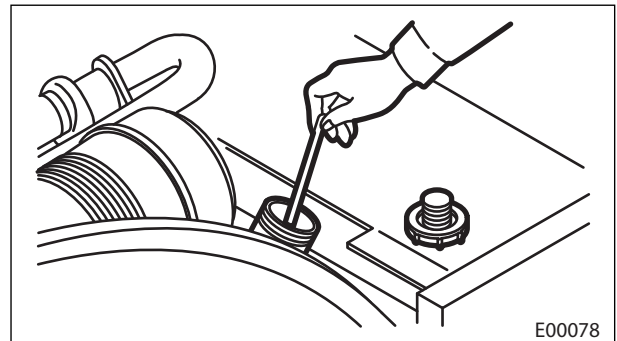

- (7) Put the drain plug back in place.

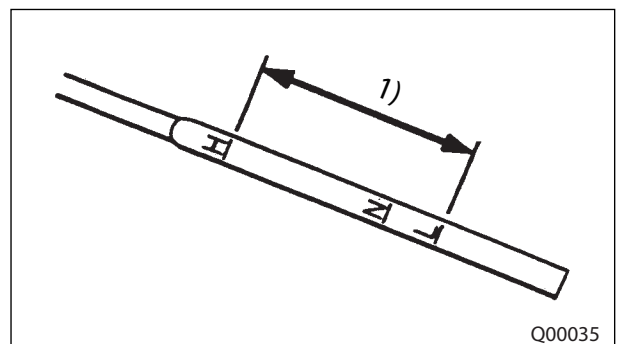

1) Correct level range

⚠ WARNING

Travel safely on grades with a loaded lift truck!

When ascending or descending grades loaded lift trucks must be driven with the load upgrade.

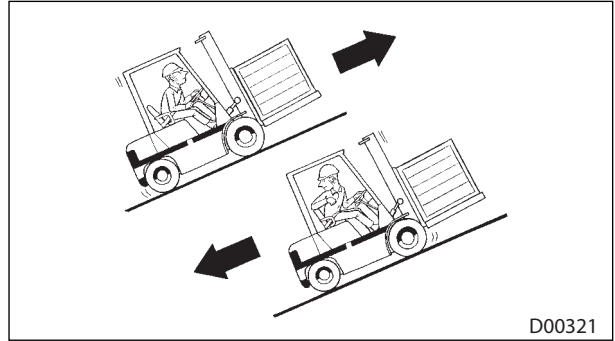

⚠ WARNING

Travel safely on grades with an empty lift truck!

Unloaded lift trucks must be operated on all grades with the forks downgrade.

When descending grades, use service brake and engine brake.

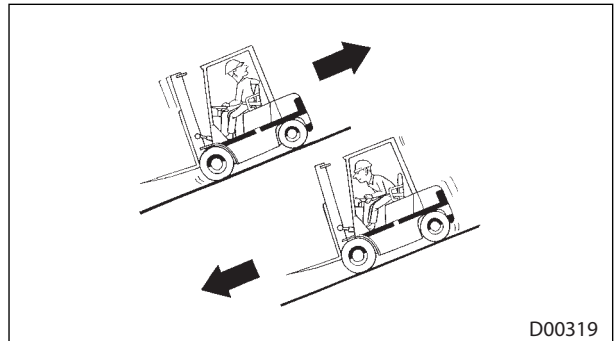

⚠ WARNING

Be particularly careful when driving up or down a steep slope!

Use extreme care to reduce the risk of fork tips or the bottom of the pallet from touching the ground.

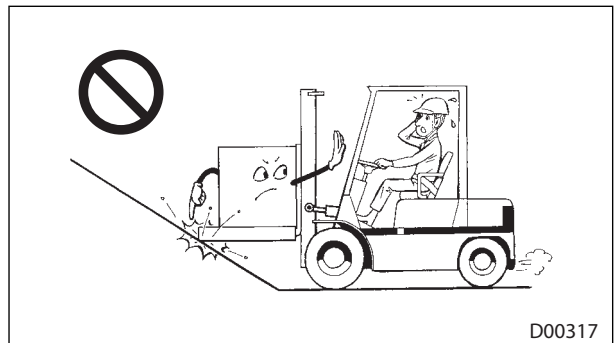

⚠ WARNING

Starting the lift truck on an upgrade carefully!

When starting the lift truck on an upgrade, BE SURE to use the parking brake.

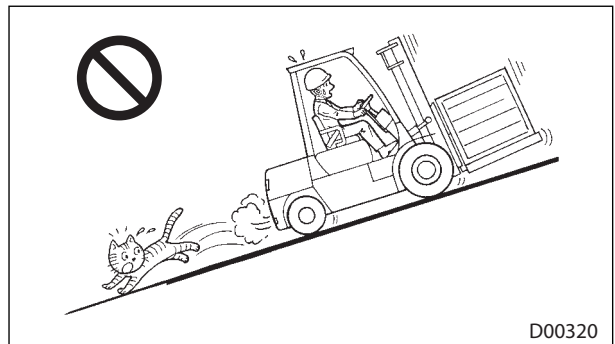

► For Standard LPG Tank

- (1) Park the lift truck on level ground.
- (2) Lower the forks until the fork tips touch the ground.
- (3) Apply the parking brake.
- (4) Place the direction lever in the NEUTRAL position.
- (5) Run the engine at low idle.
- (6) Discharge the static electricity.
- (7) Close the fuel valve on the LPG tank. Run the engine until it stops, then turn the key switch to the OFF position.
- (8) Disconnect the fuel supply line.
- (9) Loosen the retaining clamps, and remove the tank.
- (10) Make sure the replacement tank is the correct type.

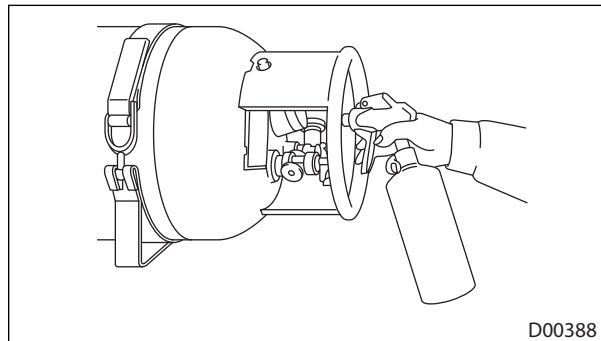

- (11) Inspect the replacement tank for damage such as dents, scrapes, or gouges and for leakage at valves or threaded connections.
- (12) Check for debris in the relief valve and for damage to various valves and the liquid level gauge.
- (13) Inspect the couplings for deterioration, damage, or missing flexible seals.
- (14) When lifting the tank for mounting, hold with both hands to prevent injury, and check the tank clamp lock.
- (15) Clamp the tank securely.
- (16) Connect the fuel supply line.
- (17) Open the fuel valve by turning it slowly counterclockwise. If the fuel valve is opened too quickly, a back pressure check valve will shut off the fuel supply. If this happens, close the fuel valve completely, wait five seconds, and then open the fuel valve very slowly.
- (18) Check the LPG fuel lines and fittings with a soap solution after filling the tank or when looking for leaks.

MAINTENANCE

► Tires and Rims

Check

⚠ WARNING

- Make sure the replacement tire is of the same size, type, and load range. See manufacturer name plate located on the front of the lift truck for correct tire size.
- When replacing tires, replace them in sets, even if only one of the tires is damaged. If new and used tires are used on the same axle, tilting of the mast and rapid tire wear will result.
- Use only tires recommended by the manufacturer.

⚠ CAUTION

The lift truck tires are highly inflated. Even slight damage to the tire or rim may cause a blowout of the tire.

How to check

- Are all the tires free of cuts, gouges, or foreign objects?
- Are all the rims free of distortion or cracks?
- Is the tread groove depth more than 5 mm (0.2 in.) when checked with a tire depth gauge?
If not, replace the tire.

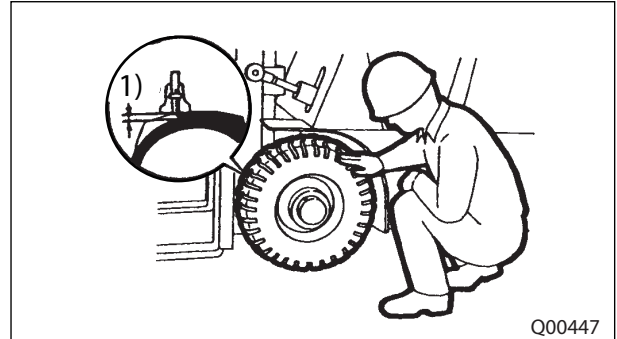

Q00447

1) Limit: 5 mm (0.2 in.)

Note:

- For replacing tires, see 10-1 "Replacing Tires".
- Contact your authorized Cat lift truck dealer when requesting to replace tires.



Operation & Maintenance Manual

MC/FC

GP15N	CT34A-02001-up	DP15N	CT16E-01001-up
GP18N	CT34A-41001-up	DP18N	CT16E-41001-up
GP20CN	CT34A-61001-up	DP20CN	CT16E-61001-up
GP20N	CT17E-01001-up	DP20N	CT18D-01001-up
GP25N	CT17E-53001-up	DP25N	CT18D-55001-up
GP30N	CT13G-02001-up	DP30N	CT14F-04001-up
GP35N	CT13G-51001-up	DP35N	CT14F-53001-up

When a serious warning of the lift truck and an engine moderate warning occur simultaneously

On main display, the diagnostic code **1)** will glow. Also, all of the five warning icons **1** shown in the illustration on the right will blink and the engine check indicator icon **2** will glow. When recovered from the serious warning of the lift truck, the diagnostic code **2)** will glow.

Also, the engine check indicator icon **2** and multi-purpose warning icon **3** stay ON.

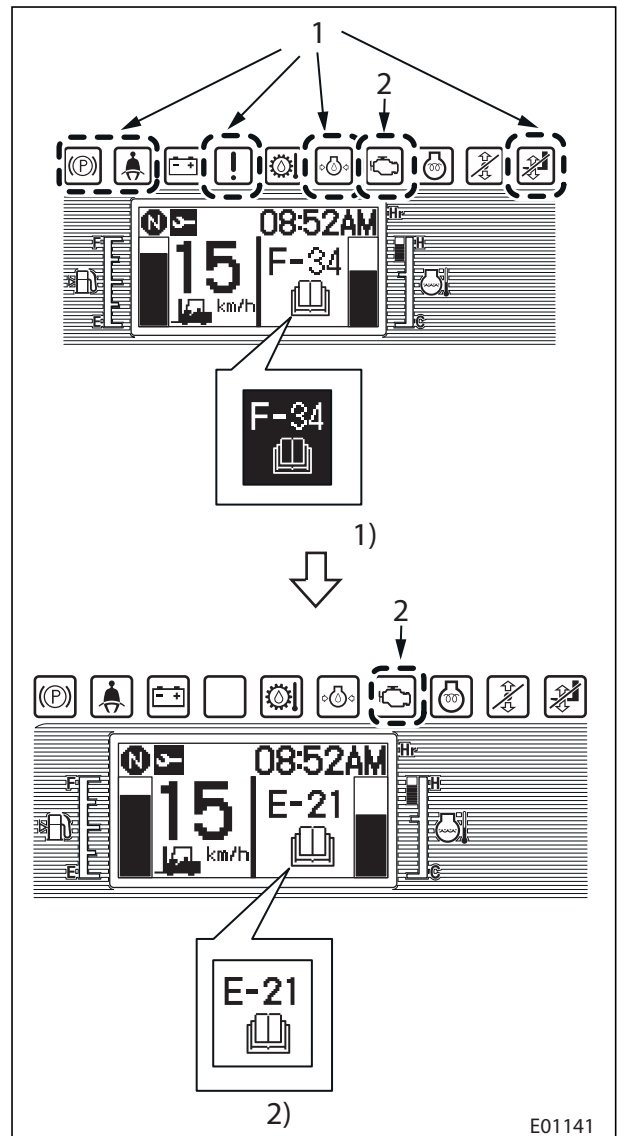

- 1. All warning icons blink
- 2. Engine check indicator icon glows
- 1) The diagnostic code with white characters on a black background glows
- 2) The diagnostic code with black characters on a white background glows

⚠ WARNING

Be careful not to drag the forks.

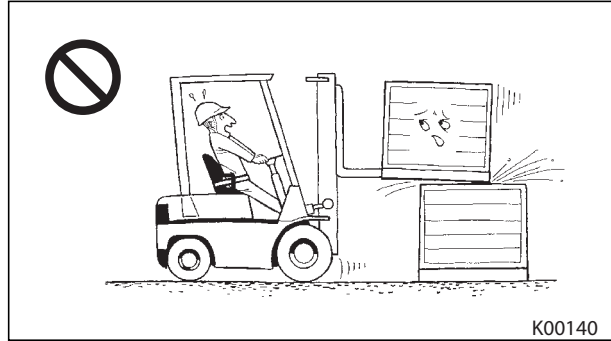

⚠ WARNING

- DO NOT travel with the mast tilted FORWARD or with the load in the elevated position. This will increase the possibility of the lift truck tipping over.
- DO NOT tilt the mast with the load in the elevated position.
- DO NOT leave the lift truck with the load in the elevated position.

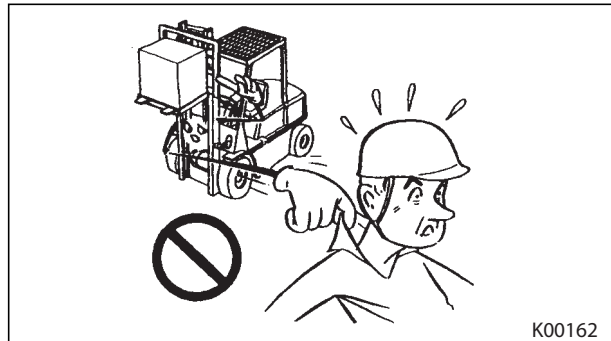

◆ Working on Grades

▶ Normal Travel position

- Keep the forks or the load at a safe travel height, which is 15 to 20 cm (6 to 8 in.) from the ground.
- Tilt the mast back more than 6° when the lift truck is empty. Tilt the mast fully BACKWARD when the lift truck is loaded.

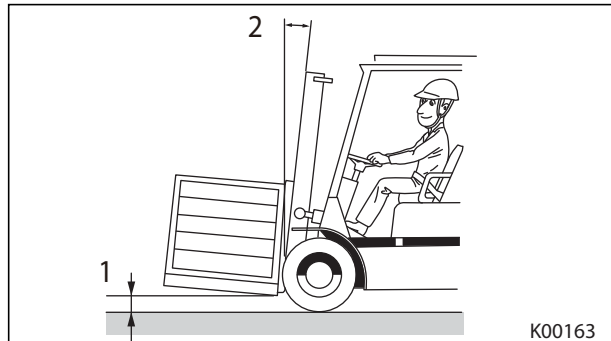

1. 15 to 20 cm (6 to 8 in.) 2. 6° Tilt back

▶ Traveling on a Grade

⚠ WARNING

- DO NOT continuously use the brake pedal alone. This could result in brake failure and an accident.
- DO NOT use the inching pedal when traveling down a grade. This prevents the engine from acting as a brake.
- DO NOT place the direction lever in the NEUTRAL position when traveling down a grade.

Travel up a grade in the FORWARD direction and down a grade in the REVERSE direction when the lift truck is loaded. When travelling down a long grade, switch the speed selector switch to 1 speed, and use engine brake and service brake.

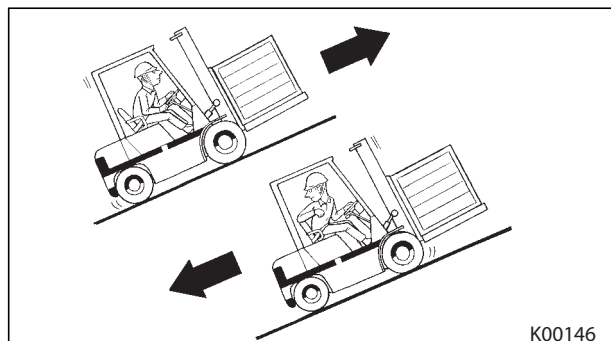

■ SERVICE DATA

◆ Fuel Information

Use only fuel recommended in this section.

▶ Diesel Fuel Specifications

- Types of Fuel
The recommended fuels provide maximum engine service life and performance. They are distillate fuels. They are commonly called diesel fuel, furnace oil, gas oil or kerosene (for cold weather operation). Mitsubishi Caterpillar Forklift Inc. strongly recommends the use of fuels that meet the recommended fuels specification.
- Fuel Sulfur Content
The percentage of sulfur in the fuel will affect the engine oil recommendations. Fuel sulfur is chemically changed during combustion to form both sulfurous and sulfuric acid. These chemically attack metal surfaces and cause corrosive wear.
- Any API classification performance of oil should have sufficient TBN for fuels with less than 0.5% sulfur. For fuels with 0.5% to 1.5% sulfur by weight, engine oil must have a TBN of 20 times the percentage of fuel sulfur as measured by the ASTM (American Society of Testing Materials) D-2896 method. (ASTM D-2896 can normally be found at your local technological society, library or college.)

▶ Liquefied Petroleum (LPG)

Specifications

Use grade HD5 LPB. LP-Gas is a highly volatile fuel with an octane rating of 100 to 140. Follow local ordinances regarding storage and/or filling of LP-Gas tanks.

⚠ WARNING**Inspect a trailer before entering!**

- The brakes on the highway trucks or trailers must be applied, and wheel chocks or other positive mechanical means must be used to prevent unintentional movement of highway trucks and trailers.
- DO NOT travel along the edge of the dock. The lift truck may fall off the dock.
- Before starting work, check the allowable load of dock plate, and if it does not have enough strength to withstand the weight of the lift truck carrying a load, do not use it.
- When entering a trailer, use outriggers so that trailer will not sink.
- Travel slowly on dock plate when getting in or out of trailers or railroad.
- Ask the driver of the trailer not to move the trailer until the work is completed.
- Use any anchoring equipment available in the dock to secure the trailer or railroad, and also secure the dock plate to prevent it from falling off.
- Obey the instructions of the supervisor when working as a team.

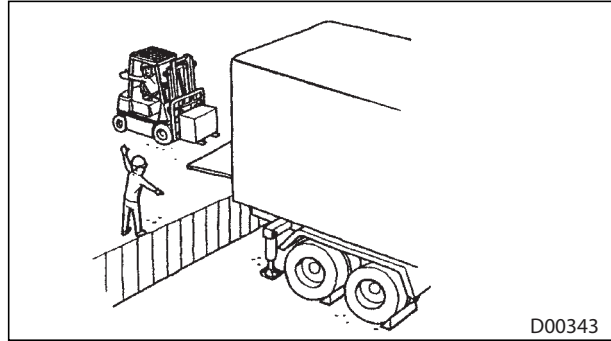

D00343

⚠ WARNING**Fork positioner operation!**

- DO NOT operate the fork positioner while carrying loads.
- DO NOT handle off-center loads.

⚠ WARNING**Side shifter operation!**

When sideshifting to pick up loads, BE SURE that forks are centered under the load. DO NOT side shift while traveling with loads.

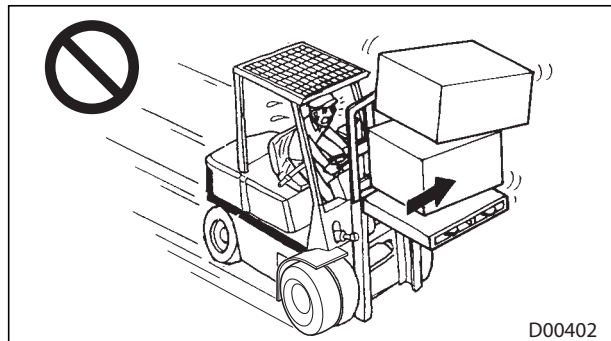

D00402

⚠ WARNING

DO NOT raise or lower a load while side shifted, as it is dangerous.

DO NOT side shift the forks with the load raised higher than 150 cm (59 in.) unless safety is assured by the load stack or carrier deck just below the forks.

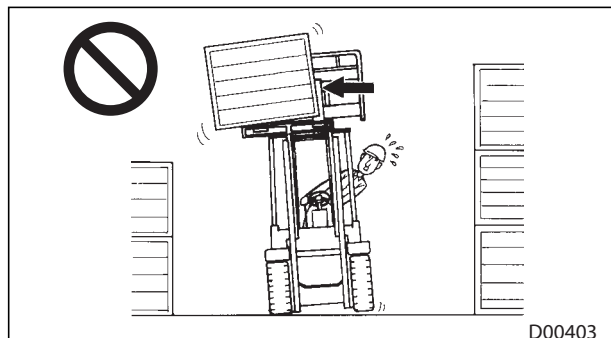

D00403

⚠ WARNING

DO NOT turn sharply, even with an empty raised mast, to avoid a tipover!

A lift truck with a raised mast will tipover more easily than a lift truck with a lowered mast because the stability of the lift truck worsens.



⚠ WARNING

Wear a hard hat if recommended or required by your employer or applicable regulations.



⚠ WARNING

Be aware of the stability of an empty lift truck!

An empty lift truck will tipover more easily than a loaded one in a lowered position.

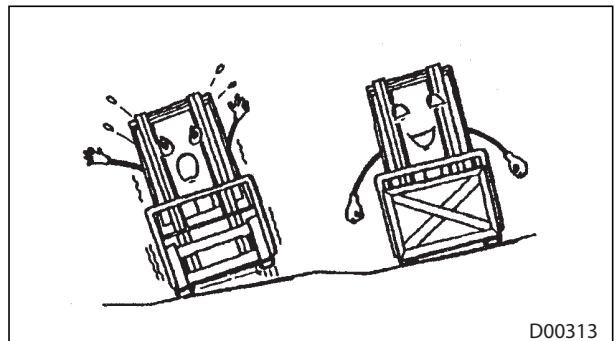

◆ How to Survive in a Tipover

⚠ DANGER

DO FASTEN YOUR SEAT BELT!

Remember, your chances for survival with the seat belt fastened in a tipover are better if you stay in the lift truck.

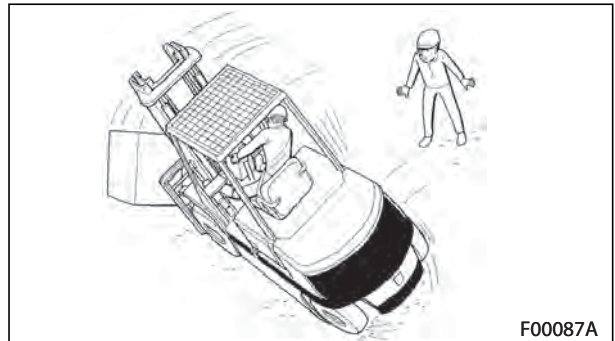

Item	Service	Page
Mast Support	Lubricate	11-37
King Pins	Lubricate	11-38
Universal Joint	Lubricate	11-38

► **Every 200 Service Hours or Monthly, Whichever Comes First**

Item	Service	Page
Mast Strip Sliding Surfaces	Lubricate	-
Lift Chains	Lubricate	-

► **Every 500 Service Hours or 3 Months, Whichever Comes First**

Item	Service	Page
Bolts and Nuts (Frame & Chassis)	Check	-
Differential Oil	Check oil level	-
Tilt Socket Pins	Lubricate	-
Tie Rod Pins	Lubricate	-
Mast Support	Lubricate	-
King Pins	Lubricate	-
Mounting Bush of Rear Axle	Lubricate	-
Fuel Filter (LPG Models)	Clean	-
Battery	Check specific gravity of electrolyte	-
Engine Oil/Oil Filter	Replace	-
Brake Drum Nuts & Bolts	Check	-
Brake Drum & Shoes	Check	-
Radiator Fin	Check / Clean	-
Electrical Wires	Check	-
Engine Idle Speed	Check	-
Intake & Exhaust Valve	Check Clearance	-
Positive Crankcase Ventilation Valves & Hoses	Check clearance	-
Tar in Vaporizer	Check / Drain	-
Injection Nozzle (LPG Models)	Check	-
Spark Plug	Check gap	-
Universal Joint	Lubricate	-

► **Every 1000 Service Hours or 6 Months, Whichever Comes First**

Item	Service	Page
Transmission Oil / Wash Strainer	Replace / Clean	-
Hydraulic Tank Return Oil Filter / Wash Strainer	Replace / Clean	-

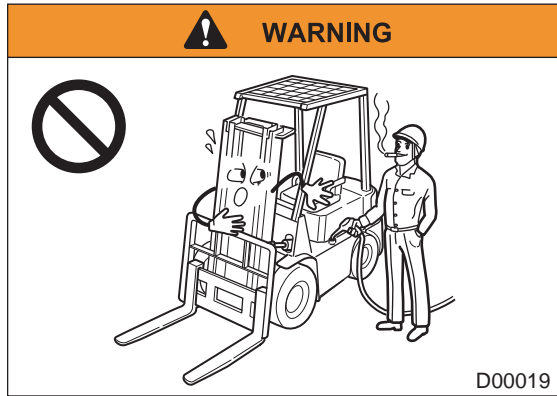

No smoking while refueling!

DO NOT fill the fuel tank while the engine is running or the operator is on the lift truck. Keep away from flames or spark sources. Turn off all electrical switches on the lift truck. Pump fuel in a well-ventilated area.

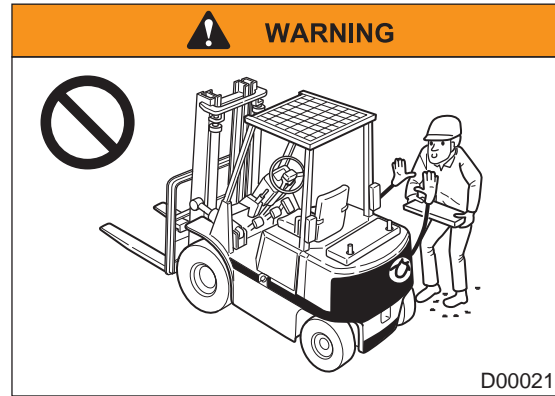

Unauthorized addition or modification is prohibited!

DO NOT add to or modify the lift truck unless authorized in writing by the manufacturer to do so. Any changes approved by the manufacturer require a new capacity plate and decals after modification.

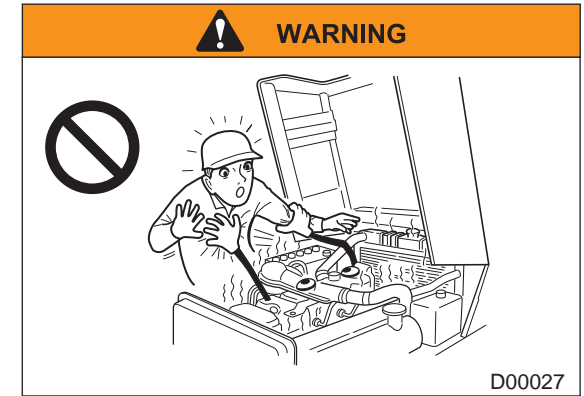

Avoid being splashed by scalding hot coolant!

Wait until the engine cools before opening or loosening the radiator cap. If you cannot wait, use a heavy cloth and gloves to protect yourself. Stand to the side, protect your face, and slowly loosen cap.



Know all signals and traffic rules!

Know who is responsible for signaling. Learn to tell at a glance what the signal means, and what action you should take.



Know the lift truck and attachments!

Read and understand the operating, inspection and maintenance instructions in the OPERATION & MAINTENANCE MANUAL and the decal on the lift truck.

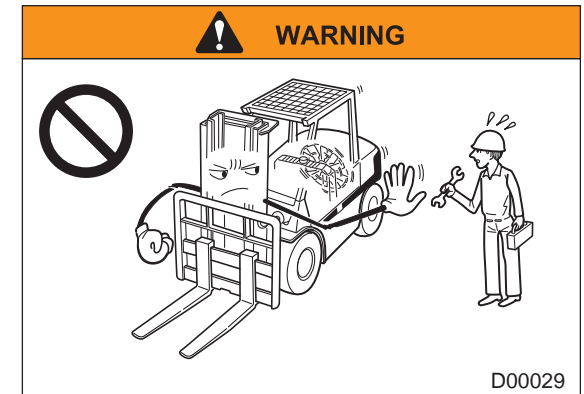

Turn OFF the key switch before servicing!

DO NOT service this lift truck while engine is running unless absolutely necessary.

◆ **How to Survive in a Tipover**

! DANGER

Remember, your chances for survival with the seat belt fastened in a tipover are better if you stay in the lift truck. If the lift truck starts to tip over:

- DO NOT jump off!
- Firmly hold on to the steering wheel.
- Brace your feet.
- Lean away from impact.
- Lean forward.

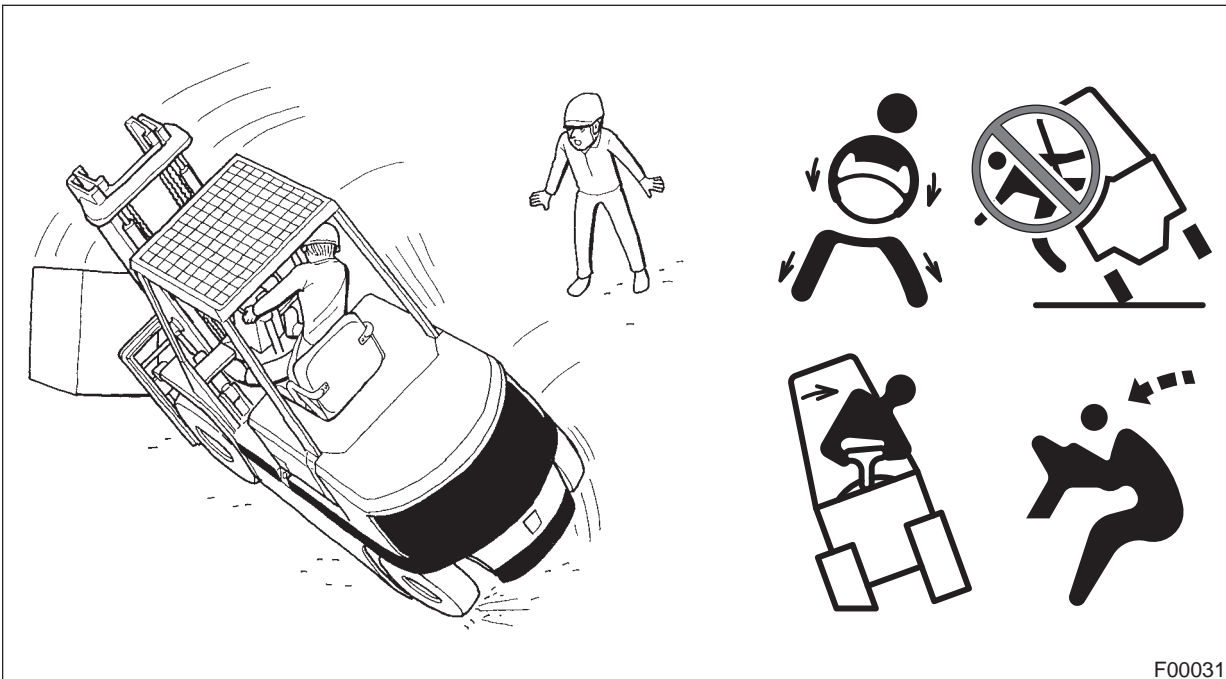

F00031

! WARNING

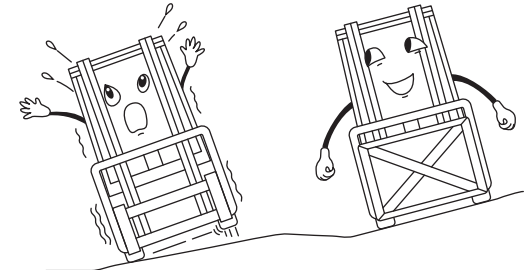

D00073

Be aware of the stability of an empty lift truck!

An empty lift truck will tip over more easily than a loaded one in a lowered position.

• **Engine Coolant**

.Check Coolant Level

Park the lift truck on level ground with forks lowered until fork tips touch the floor, parking brake applied, direction lever in neutral position and engine stopped. Block the wheels securely.

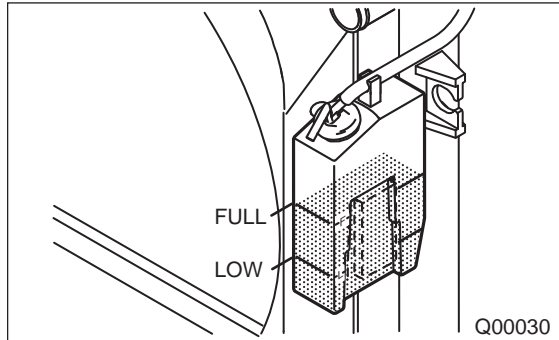

1. Raise the engine hood.
2. Maintain the coolant level between the FULL and LOW marks on the reserve tank.
3. Close and secure the hood.

Adding Coolant

! WARNING

Keep fire away from undiluted antifreeze as it is FLAMMABLE.

! CAUTION

DO NOT add water only. This dilutes the anti-freeze/summer coolant protection and adversely affects the engine. BE SURE to premix antifreeze/summer coolant (ASC) with tap water (soft water).
If coolant has to be added frequently, have your authorized Cat lift truck dealer check the cooling system.

! CAUTION

- Recommended concentration range of ASC is 30% to 60% by volume.
- ASC of less than 30% concentration does not provide sufficient corrosion protection.
- Concentrations over 60% adversely affect freeze protection and heat transfer rates.
- Avoid mixing different brands of coolant.
- Select an ASC suitable for use in engines using aluminum alloy parts.
- Select an ASC which contains silicate of less than 0.2% by weight.

◆ Decals for Dual Fuel Only

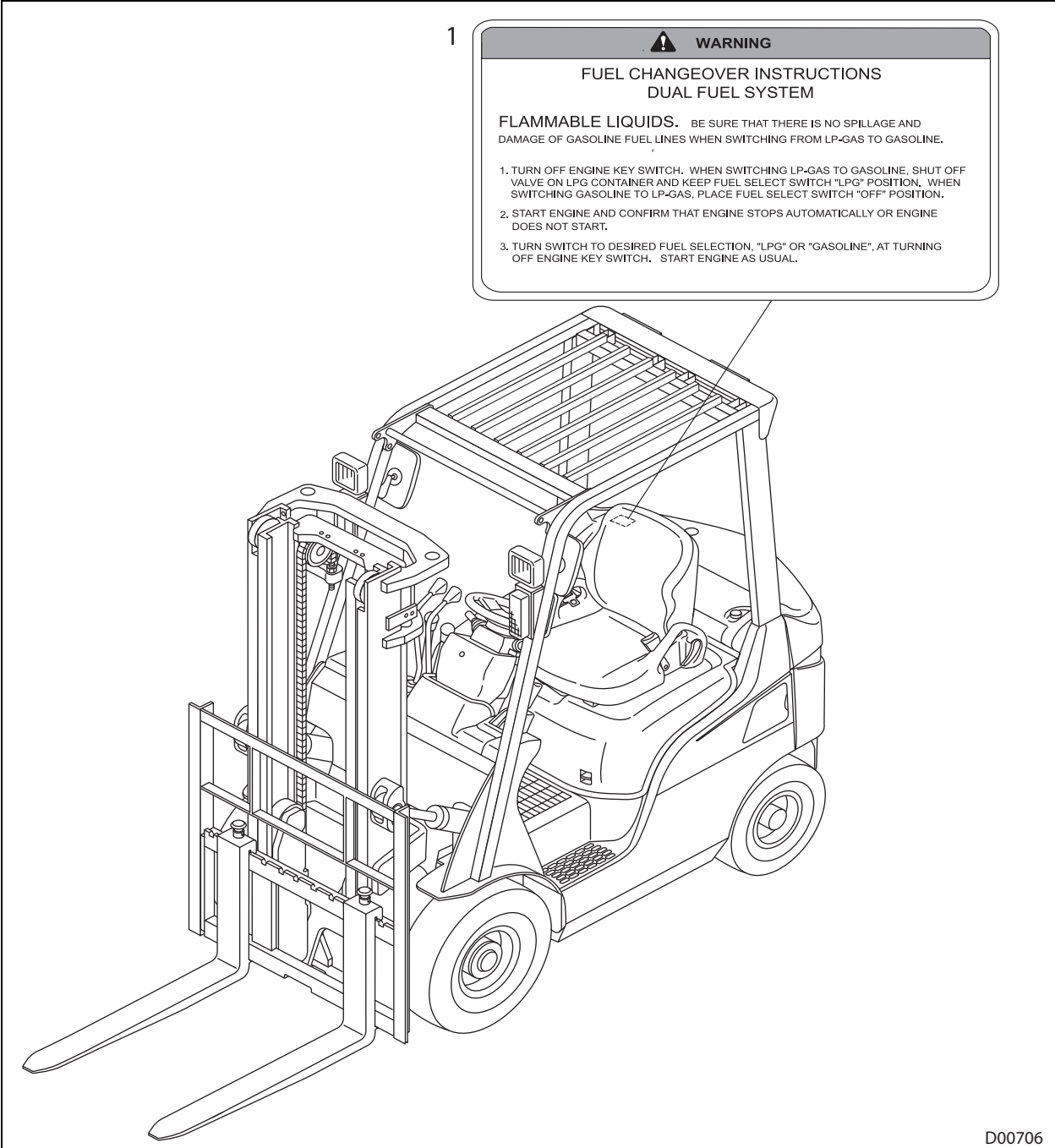

1. Dual Fuel Inst. decal

◆ Operator Seat

► Seat Adjustment

⚠ WARNING

Adjust the operator seat slide forward and back position before starting the engine. After adjusting, check the operator seat to make sure it is properly locked. DO NOT adjust the operator seat while the lift truck is in motion.

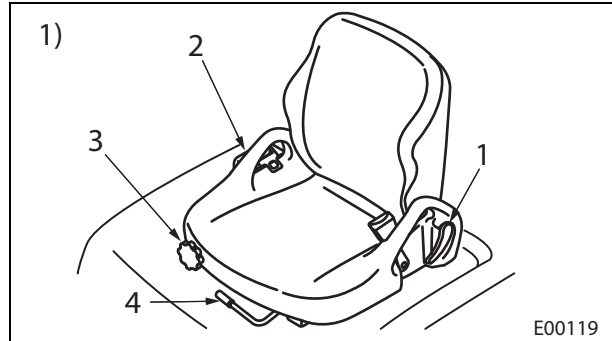

- | | |
|--------------------|-------------------|
| 1) MC model | 3. Adjusting knob |
| 1. Reclining lever | 4. Side lever |
| 2. Seat belt | |

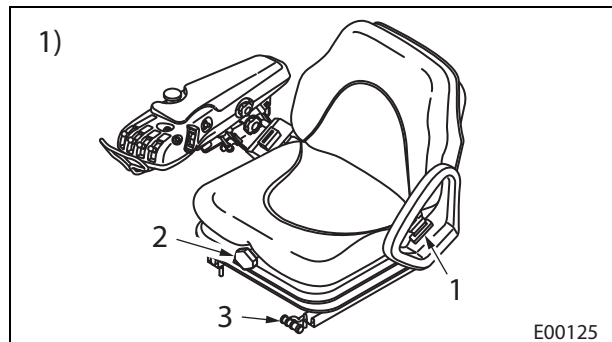

- | | |
|--------------|-------------------|
| 1) FC model | 2. Adjusting knob |
| 1. Seat belt | 3. Side lever |

► Forward and Back Adjustment

Move the lever, slide the seat to one of the eleven positions, and release the lever.

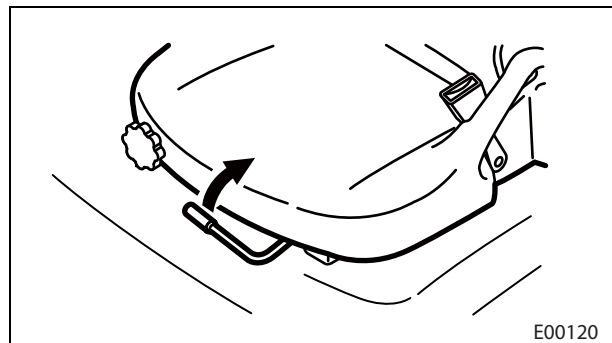

⚠ WARNING

Your lift truck comes equipped with a genuine Cat Lift Truck operator restraint system and an operator presence switch. Should it become necessary to replace the seat for any reason, it must only be replaced with a genuine Cat Lift Truck operator restraint system equipped with an operator presence switch.

◆ Stalled Engine

If the engine stalls, hydraulic pressure is lost in the power steering. This increases your steering effort.

In this case, stop your Lift truck in a safe area and restart the engine.



► Before Starting the Engine Again

Check the following items, and remove the cause of the stall.

- Lack of fuel
- Engine overloading

(23) Put the reserve tank filler cap back on.

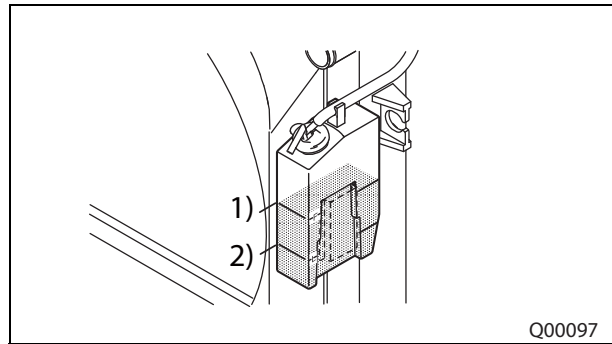

1) FULL

2) LOW

Q00097

► Fuel Filter (LP-Gas Engine)

Change

Note: Park the lift truck in an authorized refueling area with the forks lowered until the fork tips touch the floor or ground, parking brake applied, direction lever in the neutral position, engine stopped and the wheels blocked. The engine must be cooled down.

- (1) Close the fuel valve on the LP-Gas tank. The fuel shutoff valve turns clockwise to close. Run the engine until fuel in the fuel line runs out and the engine stops. Turn the key switch to OFF.
- (2) Raise the engine hood.

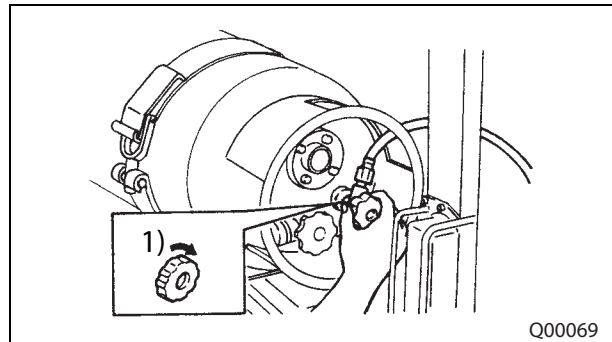

1) Close

Q00069

- (3) Disconnect the fuel line.
- (4) Remove the fuel lock filter.

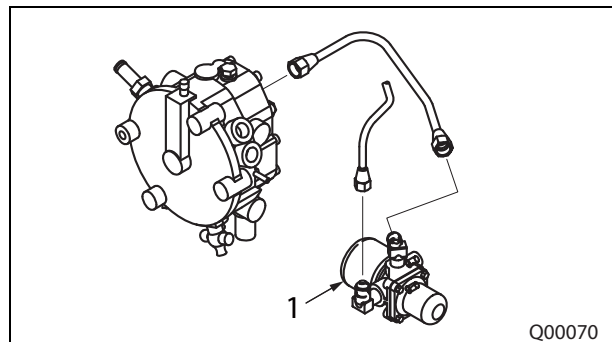

1. Fuel lock filter

Q00070

OPERATION

Powershift model

(1) Release the accelerator pedal.

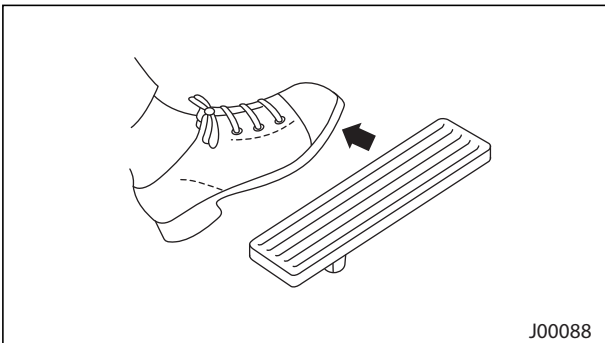

(2) Press the brake pedal and come to a complete stop.

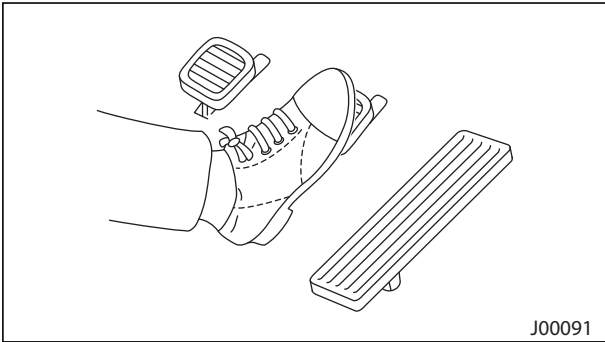

(3) Pull the parking brake lever all the way back.

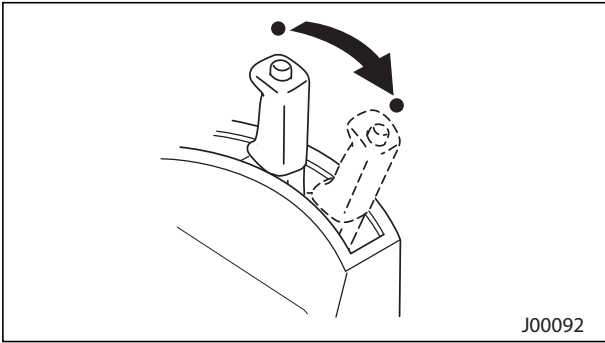

(4) Place the direction lever to the NEUTRAL position.

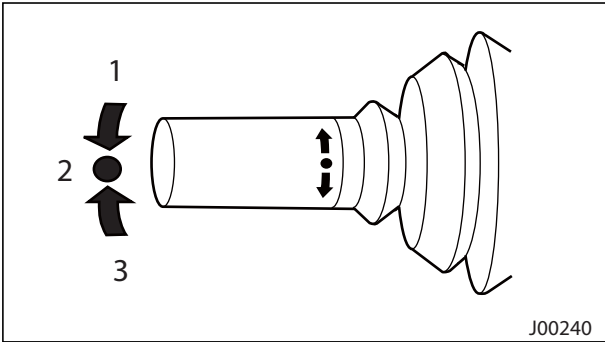

- 1. Forward (F)
- 2. Neutral (N)
- 3. Reverse (R)

MAINTENANCE

► Inching Pedal (Powershift Model)

- Is the free play correct?
- Does the inching pedal return to the full, upward position?

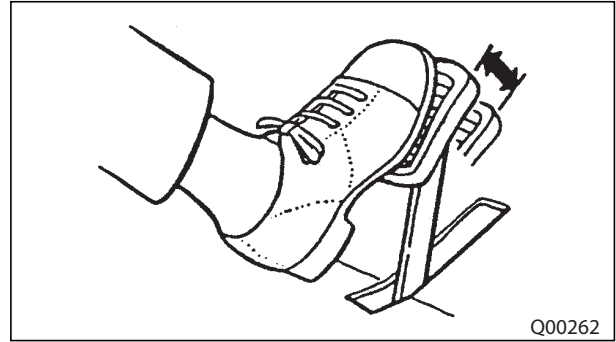

Q00262

Correct free play

Models	Value
1 to 3.5 ton	2.5 to 7.5 mm (0.1 to 0.3 in.)

► Clutch Pedal (Manual Model)

Check the play of clutch pedal.

Play	
1 to 3.5 ton	0.6 mm (0.02 in.)

► Accelerator Pedal

- Can you press the accelerator pedal smoothly without any sign of rubbing?
- Does the accelerator pedal return to the full, upward position?

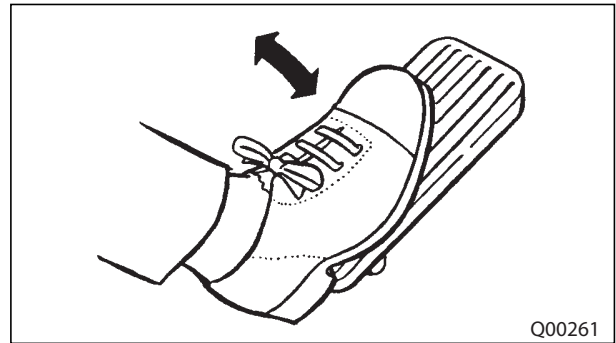

Q00261

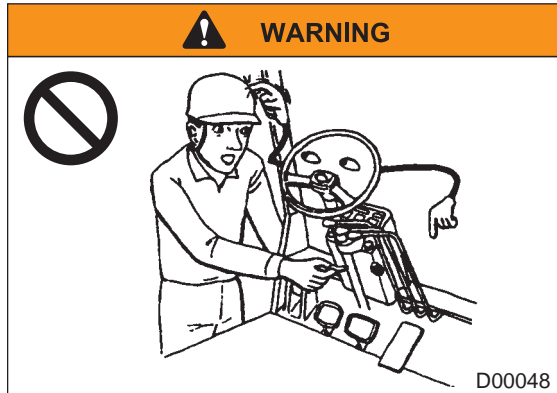

Start the engine only when seated in the normal operating position!



Face the lift truck when mounting and dismounting!

Maintain a three point contact (one foot and two hands) with the floor and handholds. **DO NOT** get on or off the moving lift truck. **DO NOT** jump on or off the lift truck. **DO NOT** use the control levers or steering wheel as handholds when entering or leaving the operator's compartment.

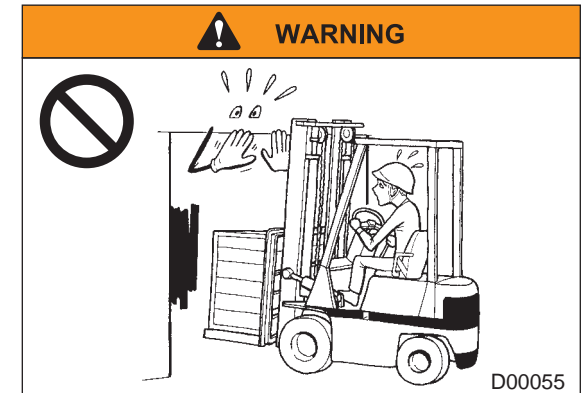

Always check overhead clearance!

Serious accidents and damages could be caused by the mast and overhead guard hitting pipes, beams or other overhead obstructions. Watch out for power lines.



DO NOT operate a damaged or defective lift truck!

If the lift truck is damaged, take it out of service until it has been restored to safe operating condition. Park it in a non-operating area and remove the key. Attach a "DO NOT OPERATE" or similar warning tag to the lift truck. Contact your authorized Cat lift truck dealer for repairs.



Adjust the operator's seat before operating the lift truck!

DO NOT adjust the operator's seat while the lift truck is in motion.

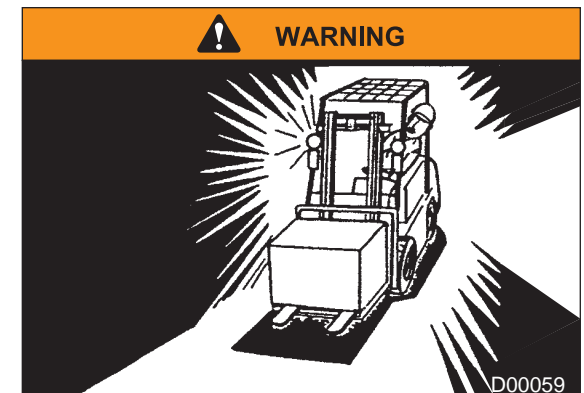

Use lights in dark, dim areas!

Even with lights on, **DO NOT** assume people see you and will move out of your way.

◆ Starting LP-Gas Engine



WARNING



LP-Gas fuel is flammable and could cause injuries and fires. Inspect LP-Gas fuel lines and fittings for leaks.

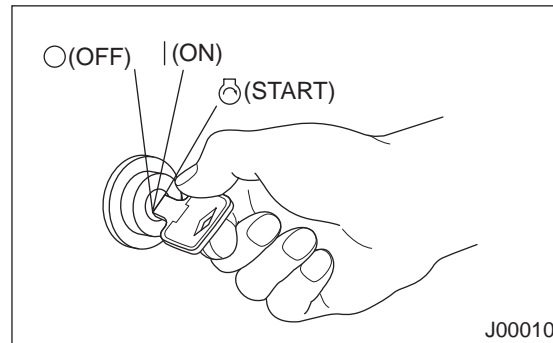

CAUTION

- DO NOT leave the key in the | (ON) position when the engine is NOT running.
- This may cause the battery to run down.



1. Open the fuel valve by turning it slowly counterclockwise. Observe the LP-Gas gauge (if equipped).
2. Turn the key switch to the  (START) position. Release it when the engine starts.
3. If the engine does not start, DO NOT press on the accelerator. Turn the key switch to the  (OFF) position, then repeat step 2.

- **Brake Hoses, Pipes and Joints**

Check

– Hoses, pipes and joints should be checked for damage, cracks and brake fluid leaks.

- **Fuel Hoses, Pipes and Joints**

Check

– Hoses, pipes and joints should be checked for damage, cracks and fuel leaks.

- **Hydraulic Hoses, Pipes and Joints**

Check

– Hoses, pipes and joints should be checked for damage, cracks and hydraulic oil leaks.

CHAPTER 1 GENERAL INFORMATION

Truck model	Class		2 ton class		3 ton class	
	Gasoline engine truck		GP20N GPE20N GP20ZN GPE20ZN	GP25N GPE25N GP25ZN GPE25ZN	GP30N GPE30N	GP35N GPE35N
	Diesel engine truck		DP20N	DP25N	DP30N	DP35N
Capacity	kg		2000	2500	3000	3500
Load center	mm (in.)		500 (19.7)	500 (19.7)	500 (19.7)	500 (19.7)
Lift speed	Loaded	mm/s (fpm)	GP20N: 520 (102.4) GPE20N: 580 (114.2) GP20ZN: 580 (114.2) GPE20ZN: 640 (126.9)	GP25N: 520 (102.4) GPE25N: 580 (114.2) GP25ZN: 580 (114.2) GPE25ZN: 640 (126.9)	GP30N: 460 (90.6) GPE30N: 510 (100.4)	GP35AN: 390 (76.8) GPE35AN: 430 (84.6)
			DP20N: 630 (124.0)	DP25N: 630 (124.0)	DP30N: 500 (98.4)	DP35AN: 420 (82.7)
	Unloaded	mm/s (fpm)	GP20N: 600 (118.1) GPE20N: 590 (116.1) GP20ZN: 660 (129.9) GPE20ZN: 660 (129.9)	GP25N: 600 (118.1) GPE25N: 590 (116.1) GP25ZN: 660 (129.9) GPE25ZN: 660 (129.9)	GP30N: 530 (104.3) GPE30N: 530 (104.3)	GP35AN: 450 (88.6) GPE35AN: 440 (88.6)
			DP20N: 660 (129.9)	DP25N: 660 (129.9)	DP30N: 530 (104.3)	DP35AN: 450 (104.3)
Travel speed (Powershift Truck)	Loaded	mm/s (fpm)	19.0 (11.8)	19.0 (11.8)	19.0 (11.8)	19.0 (11.8)
	Unloaded	mm/s (fpm)	19.5 (12.1)	19.5 (12.1)	19.5 (12.1)	19.5 (12.1)

7.3 Lightning-related Problem

Condition		Possible cause	Action
Lights (in general)	Will not glow (blink) with the switch turned on	Battery is discharged	Charge or replace battery
		Burned-out fuse	Check and correct the cause, then replace
		Disconnection or poor connection	Repair or replace
		The ground wire is faulty	Remove corrosion from the terminal or retighten
		Blow-out bulb	Replace
	Light glows (blinks) dimly	Battery is weak	Check and charge
		Switch contact is faulty	Repair or replace
		Terminal contact is poor	Repair
		Lens are dirty	Clean
		Water drops on the inside of the lenses	Dry and replace the packing
		Bulb life has expired	Replace
Head light	Light will not turn on	Defective light switch conductivity	Replace
		Blow-out bulb	Replace
Turn signal light	Light does not blink	Turn signal switch continuity is faulty	Replace
		Turn signal relay is faulty	Replace
	Light will not go off	Turn signal relay is faulty	Replace
	Light blinks too slowly	Bulb wattage is smaller than the specification	Replace it with a specified wattage bulb
		Turn signal relay is faulty	Replace
	Light blinks too fast	Bulb wattage is larger than the specification	Replace it with a specified wattage bulb
		Blow-out bulb	Replace
		Turn signal relay is faulty	Replace
Other lights	Back-up light does not glow	Back-up light switch is faulty	Correct if improperly installed, or replace if internally defective
		Blow-out bulb	Replace
	Licence plate light does not glow	Defective light switch conductivity	Replace
		Blow-out bulb	Replace

10.3 LED Blink Pattern

When diagnostic codes cannot be identified due to meter panel failure etc., or due to a VCM1-M communication circuit problem, GSE cable damage or no presence of GSE, diagnostic codes can be identified, to some extent, by the LED blink pattern of the VCM1-M controller.

Note: Place the key switch in the ON position for checking.

LED blink pattern	LED blinking status
A	<p>Lighting 1.2 (sec.)</p> <p>OFF 1.2 1.2</p>
B	<p>Lighting 1.2 0.3 (sec.)</p> <p>OFF 0.6 2.7</p>
C	<p>Lighting 1.2 0.3 0.3 (sec.)</p> <p>OFF 0.6 0.6 1.8</p>
D	<p>Lighting 1.2 0.3 0.3 0.3 (sec.)</p> <p>OFF 0.6 0.6 0.6 0.6 0.9</p>
E	<p>Lighting 1.2 0.3 0.3 0.3 0.3 (sec.)</p> <p>OFF 0.6 0.3 0.3 0.3 0.9</p>
F	<p>Lighting</p> <p>OFF (No change: LED light remains ON or OFF.)</p>

Diagnosis	Attachment 3 Lever Neutral Warning (F14)
Logic conditions	· Attachment 3 lever open angle is 20% or more. (when key switch is ON)  F14
Recovery	Auto recovery when the lever is placed in neutral.
Action	· Turn OFF all solenoid outputs of operating functions. · Turn OFF the unload solenoid.
LED blink pattern	C

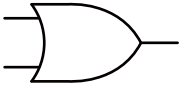
Diagnosis	Shift Lever Warning (F16)
Logic conditions	· Shift lever overlap input · No shift lever signal (1800 ms continuity)  F16
Recovery	Auto recovery
Action	· Turn OFF the T/M forward/backward solenoids outputs.
LED blink pattern	C

Diagnosis	Vehicle Speed Warning (F17)
Logic conditions	· Speed > 30 km/h (18.6 MPH) (400 ms continuity)  F17
Recovery	Auto recovery
Action	· With T/M shift lock control, neglects the speed. · Speed of 0 km/h (0 MPH) is sent to other controllers.
LED blink pattern	C

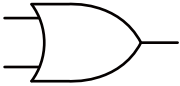
Diagnosis	Oil pressure sensor main warning (F30)
Logic conditions	· Input signal is 0.1V or less (400 ms continuity) · Input signal is 4.9 V or more (400 ms continuity)  F30
Recovery	Turn on power again after registering vehicle set up data.
Action	· Indication only
LED blink pattern	A

Clutch disc

Item		Specified value	
1	Facing thickness	Standard	6.0 ± 0.3 mm (0.236 ± 0.011 in.)
		Limit	One side: 1.6 mm (0.063 in.)
			Both sides: 5.2 mm (0.205 in.)
-	Disc runout (at rim)	Standard	0.7 to 1.2 mm (0.028 to 0.047 in.)

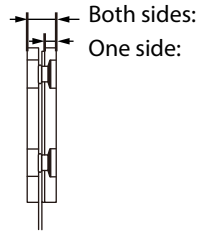

502980

4. Torque Converter Transmission, Disassembling

4.1 Preparation

Draining transmission oil

- (1) Install a wire so that the torque converter assembly will not slip out.
- (2) Remove the oil drain plug and drain the transmission oil.

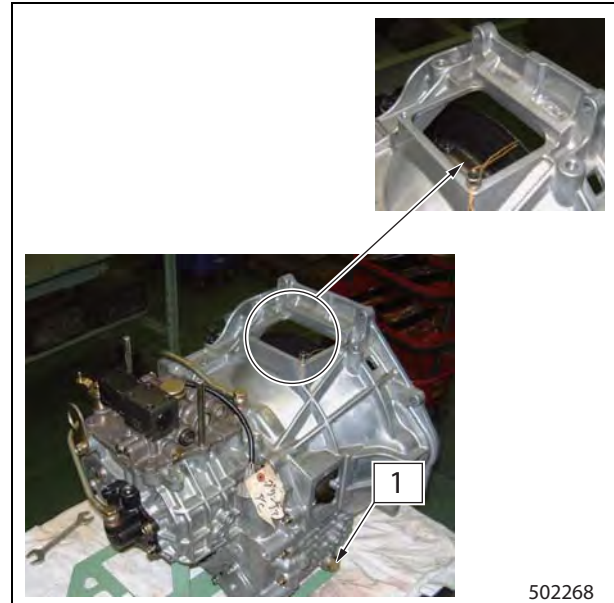

1. Oil drain plug

Item	Capacity
Transmission oil	10 L (2.64 US gal.) (All models)

Setting transmission on stand

Place the transmission in the stand (special tool).



1. Special tool (stand)

Special tool	Part number
Stand	91A68-03500



1. Main orifice plug

Ref.	Tightening torque
1	6 to 8 N·m (0.6 to 0.8 kgf·m) [4.43 to 5.90 lbf·ft]

Plug, Installing

- (1) Secure the control valve body in a vise.
- (2) Install O-ring to each plug (seven in total) and install the plugs on the control valve body by tightening to the specified torque.

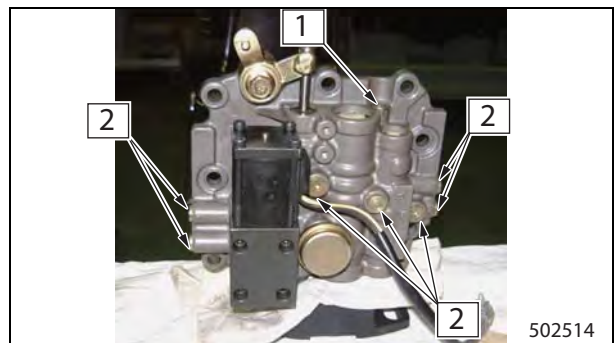

1. Main orifice plug

2. Plug

Ref.	Tightening torque
2	6 to 8 N·m (0.6 to 0.8 kgf·m) [4.43 to 5.90 lbf·ft]

6.3 Suggestions for Disassembly

Return spring, Removing

Remove return spring from shoe guide plate using special tool.

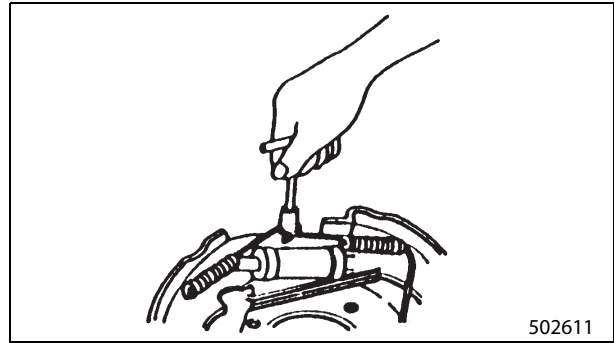

Special tool	Part number
Spring remover	64309-15411

Hold-down spring, Removing

Remove shoe hold-down spring from backing plate using special tool.

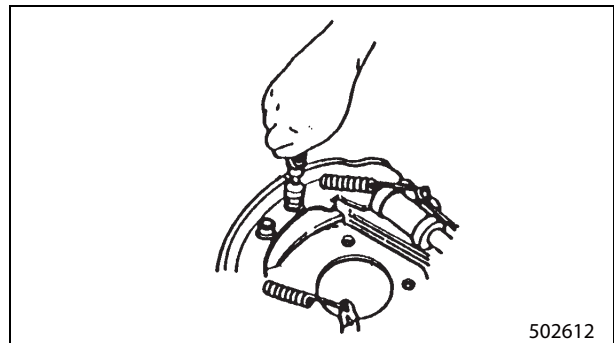

Special tool	Part number
Spring retainer	64309-15412

Cylinder with a return pipe

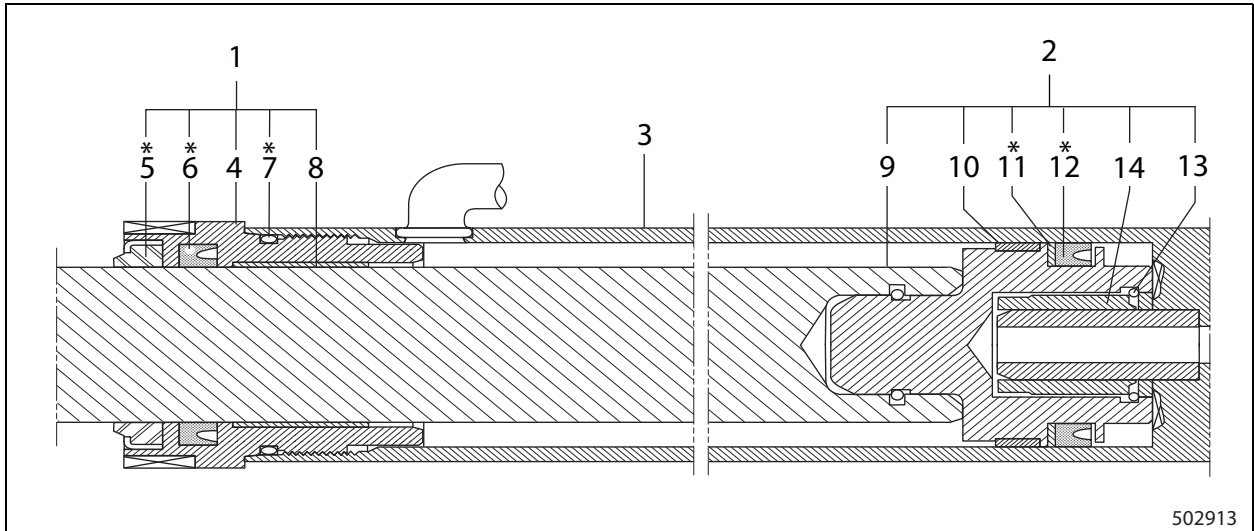

- | | |
|--|--|
| <ul style="list-style-type: none"> 1. Head subassembly 2. Piston rod subassembly 3. Cylinder tube subassembly 4. Cylinder head 5. Wiper ring* 6. U-ring* 7. O-ring* 8. Bushing | <ul style="list-style-type: none"> 9. Piston rod assembly 10. Bushing 11. Back-up ring 12. U-ring 13. Snapping 14. Cushion bearing |
|--|--|

Note: Parts marked with * are cylinder repair kits. Presence or absence of spacer depends on the specification.

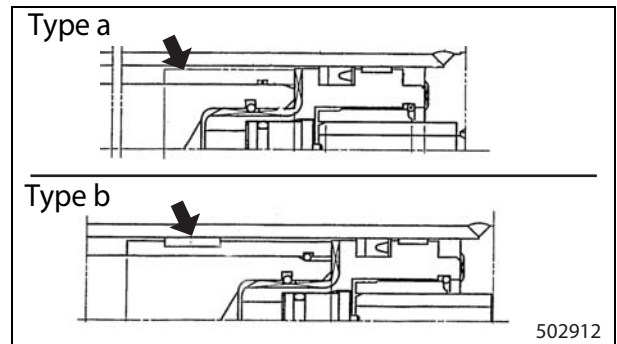

With spacer

14.2 Suggestions for Disassembly

Removing piston

Be careful not to damage the piston seals and cylinder bore surface when pulling out the piston from the cylinder.

1.24 Adjusting Mast Tilt Angle (All Mast Models)

- (1) Adjust tire air pressure and park the truck on level ground.
- (2) Tilt the mast fully backward and turn the engine OFF.
- (3) Measure the backward tilt angle of the right and left masts.
- (4) Adjust the cylinder stroke by loosening the tilt cylinder socket bolt and then turn the tilt cylinder rod so that the backward tilt angle of the mast on each side is the same.

Note: Once the backward tilt angle has been properly adjusted, there is no need for forward tilt adjustment as it is determined by the tilt cylinder stroke.

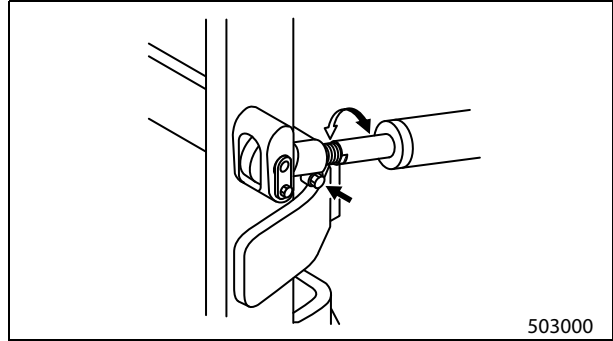

Item	Forward tilt angle	Backward tilt angle
Standard tilt angle	6°	12°

- (5) After adjustment, tighten the tilt cylinder socket bolts to the specified torque.

Item	Tightening torque
Tilt cylinder socket bolt	157 to 182 N·m (16.0 to 18.6 kgf·m) [115.80 to 134.24 lbf·ft]

1.25 Inspecting and Adjusting Right and Left Lift Cylinder Stroke (All Mast Models)

Inspection

- (1) Slowly raise the inner mast, and observe how the piston rods, left and right, stop at the moment the inner mast reaches its maximum height.
- (2) If the top of the inner mast jolts at that moment, adjust shim thickness.
Abnormal condition can be detected by a little time lag in stopping between the piston rods, left and right, and shaking of the rod with a longer cylinder stroke.

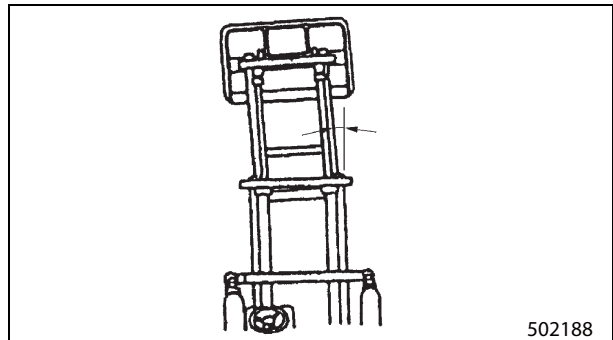

Adjustment

- (1) Raise the inner mast, place wood blocks under the right and left sides of the inner mast, and lower the mast until it rests on the wood blocks.
- (2) Remove the set bolt at the top of lift cylinder which showed earlier stroke end, retract the piston rod, and insert shims at the top of piston rod end.

Note: When retracting the piston rod, push the lift lever to lowering direction for releasing the oil in the cylinders.

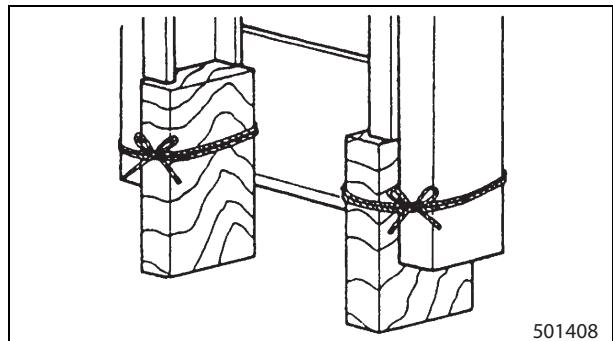

3.29 Service Data

Item			Specified value			
			1 ton class	2 ton class	3 ton class	
Chain length (20 links)			Standard	317.5 mm (12.500 in.)	381 mm (15.00 in.)	508 mm (20.00 in.)
			Limit	327 mm (12.87 in.)	392 mm (15.43 in.)	523 mm (20.59 in.)
Main roller outside diameter		S	Standard	99 mm (3.90 in.)	113.8 mm (4.480 in.)	113.8 mm (4.480 in.)
		M	Standard	100 mm (3.94 in.)	115 mm (4.53 in.)	115 mm (4.53 in.)
		L	Standard	101 mm (3.98 in.)	116 mm (4.57 in.)	116 mm (4.57 in.)
		LL	Standard	102 mm (4.02 in.)	117 mm (4.61 in.)	117 mm (4.61 in.)
Side roller external diameter			Standard	42 mm (1.65 in.)	42 mm (1.65 in.)	42 mm (1.65 in.)
Triplex mast size (reference)	1	Width of outer mast	Standard	610 mm (24.02 in.)	670 mm (26.38 in.)	670 mm (26.38 in.)
	2	Width of outer mast	Standard	516 mm (20.31 in.)	568 mm (22.36 in.)	568 mm (22.36 in.)
	3	Width of inner mast	Standard	426 mm (16.77 in.)	468 mm (18.43 in.)	468 mm (18.43 in.)
	4	Width of lift bracket	Standard	317 mm (12.48 in.)	357 mm (14.06 in.)	357 mm (14.06 in.)
Mast	5	Clearance between main roller rolling face and mast	Standard	1.0 mm (0.039 in.) or less		
	6	Clearance between main roller side face and mast	Standard	0.1 to 0.5 mm (0.004 to 0.020 in.)		
	7	Clearance between mast and mast strip	Standard	0.1 to 0.5 mm (0.004 to 0.020 in.)		
Lift bracket	5	Clearance between main roller rolling face and inner mast	Standard	1.0 mm (0.039 in.) or less		
	6	Clearance between middle roller side face and inner mast thrust face	Standard	0.1 to 0.5 mm (0.004 to 0.020 in.)		
	6	Clearance between lower roller side face and inner mast thrust face	Standard	0.1 to 0.5 mm (0.004 to 0.020 in.)		
	8	Clearance between side roller rolling face and inner mast	Standard	0.1 to 0.5 mm (0.004 to 0.020 in.)		
Distortion of finger bar			Standard	5 mm (0.20 in.) [0.20 in.] or less		

3.24 List of Lights

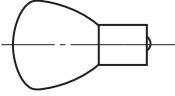
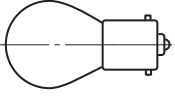
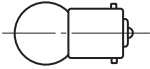
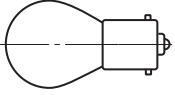
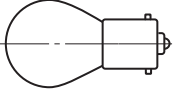
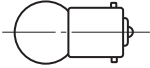
Item		Qty	Lens color	Bulb	Remark	
				Figure		
Type of lights	Head light	2	Colorless		STD	
	Combination light (front)	Turn signal light	2	Orange		STD Mounted on the overhead guard
		Clearance light	2	Colorless		
	Combination light (rear)	Turn signal light	2	Orange		STD
		Tail light and stop light	2	Red		STD
		Backup light	2	Colorless		STD

3. Console Box

3.1 Disassembly

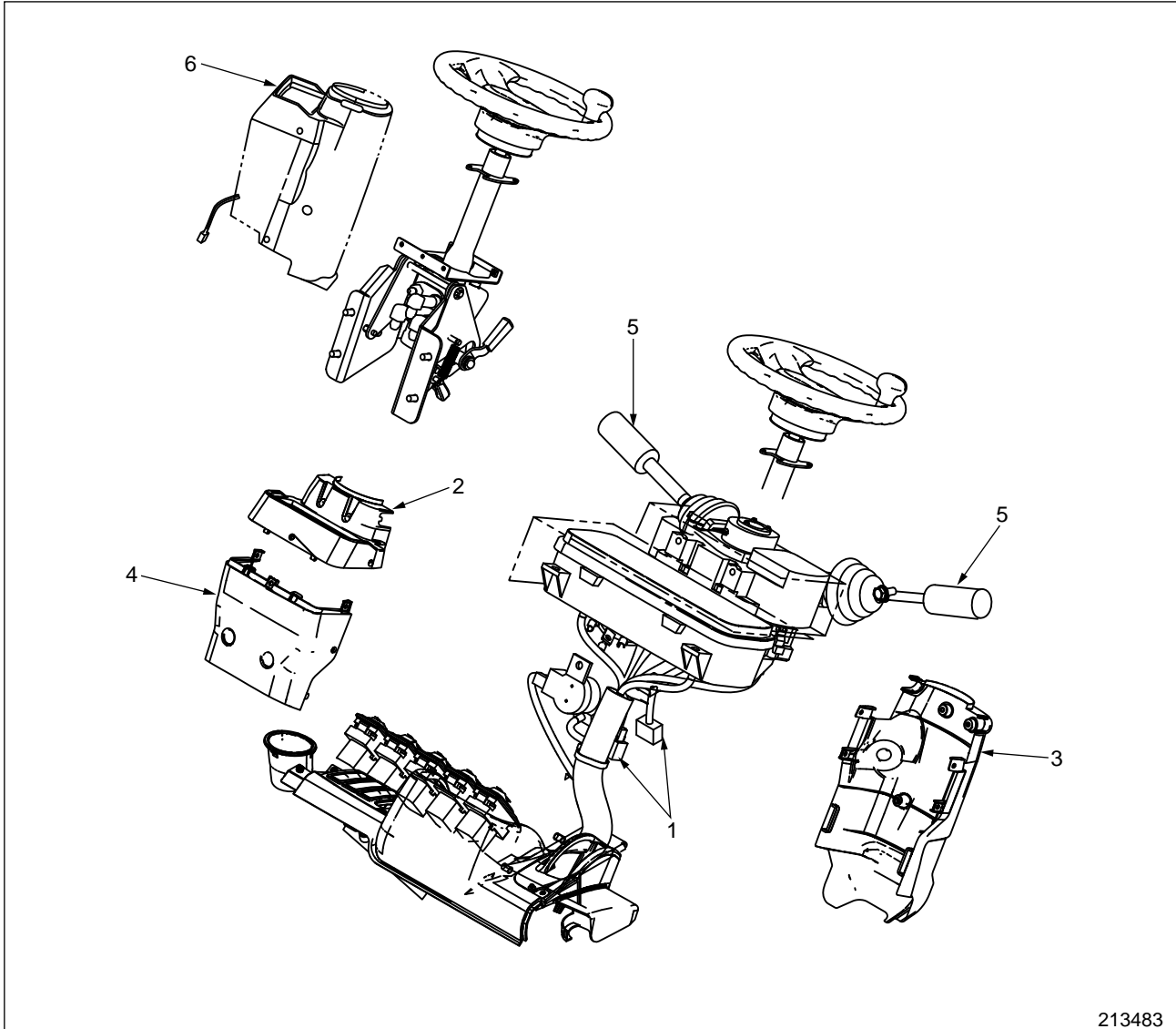

213483

3.1.1 Start by

Place the key switch to the OFF position, and remove the cable from the ground side of the battery.

3.1.2 Removal sequence

- (1) Disconnect the electrical wiring from connector 1.
- (2) Remove the screw using a Phillips screwdriver and remove cover 2.
- (3) Remove the screw and then, remove cover (U-Re) 3.
- (4) Remove the screw and then, remove cover (U-Fr) 4.
- (5) Remove direction lever (FNR lever), turn signal lever 5.
- (6) Remove the bolt and then, remove console box assembly 6.

3.1.3 Installation

To install, follow the removal sequence in reverse.

- (5) Display the output monitor screen (VCM-1M) from the service tool.
- (6) Place the direction lever in the FORWARD position. Make sure that shift lever (F) Input and T/M control valve (F) output indicate ON and the T/M control valve current is 2000mA or around on the screen. (Fig. 2-2)

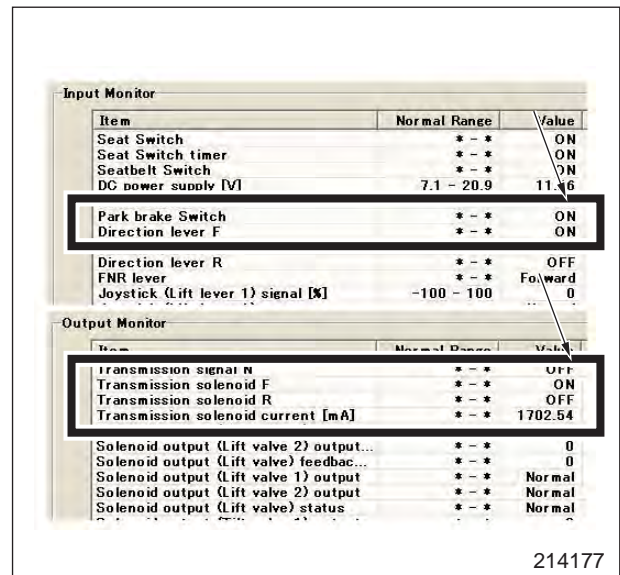

Fig. 2-2 Input/output monitor screen

- (7) Leave the operator's seat. Make sure that seat switch is turned OFF. Then, by the function of the seat delay counter, Seating flag turns OFF in a few seconds after seat switch indicates OFF. (Fig. 2-3 and Fig 2-4)

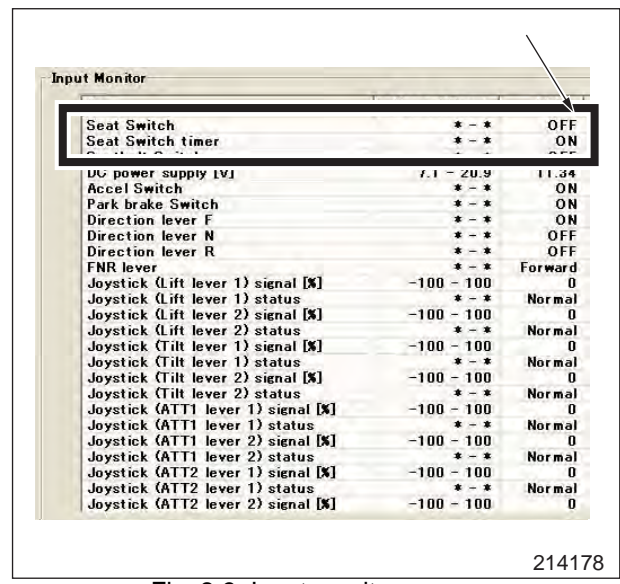

Fig. 2-3 Input monitor screen

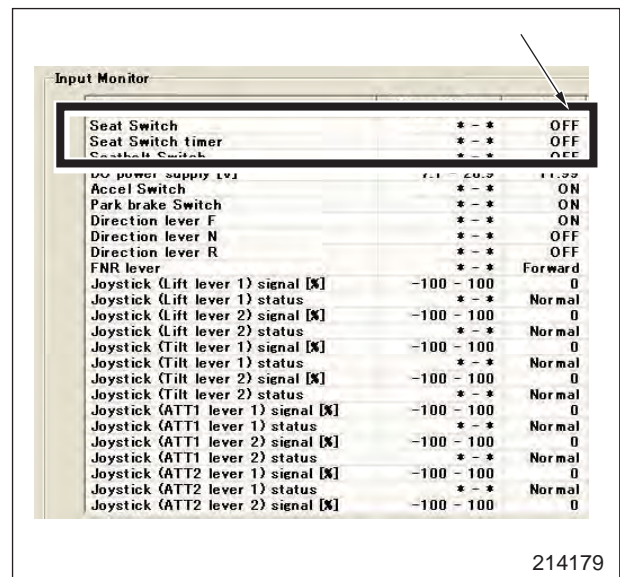

Fig. 2-4 Input monitor screen

4.6 Transmission Housing, Disassembly

4.6.1 Output gear oil seal, Removal

- (1) Install transmission housing to special tool (stand kit, 91A68-00020).

Part name	Part number
Stand kit	91A68-00020

- (2) Remove the output gear oil seal.

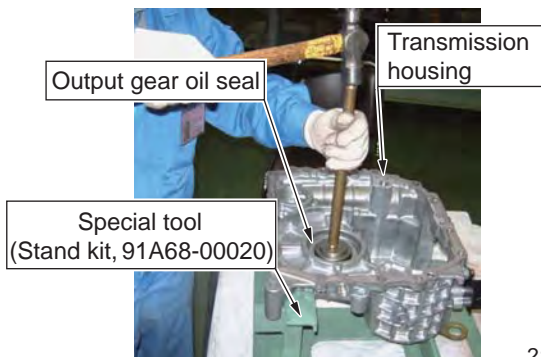

214944

4.6.2 Input shaft bearing outer race, Removal

- (1) Remove transmission housing from special tool (stand kit, 91A68-00020), and place transmission housing so that the mounting surface of servo case faces upward on a wooden block.
- (2) Special tool (Installer and Remover, 91A68-02300).

Part name	Part number
Installer & Remover	91A68-02300

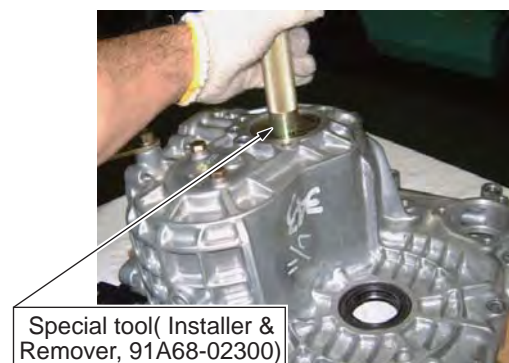

214945

4.6.3 Idler gear bearing outer race, Removal

- (1) Remove two drain plugs together with gasket.
- (2) Tighten special tool (bolts, 67281-15400), and remove idler gear bearing outer race.

Part name	Part number
Bolt	67281-15400



214946



214947

10.Service Data

Unit: mm(in.)

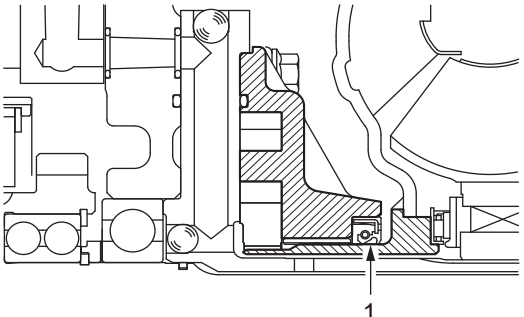
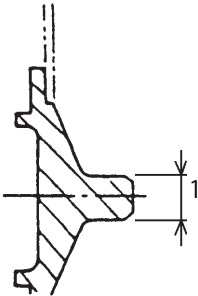
Item		Truck type		
		1 ton class	2 ton class	3 ton class
Main oil pressure, Engine at 1600 ± 100 min ⁻¹ (rpm)	MPa (kgf/cm ²)[psi]	A	Forward:1.25 ± 0.03 (12.75 ± 0.31)[181.3 ± 4.4]	
Clutch oil pressure, Engine at 1600 ± 100 min ⁻¹ (rpm)	MPa (kgf/cm ²)[psi]	A	Forward: 1.21 ± 0.03(12.34 ± 0.31)[175.5 ± 4.4] Reverse:1.18 ± 0.03(12.03 ± 0.31)[171.1 ± 4.4]	
Torque converter inlet oil pressure, Engine at 1600±100 min ⁻¹ (rpm)	MPa (kgf/cm ²)[psi]	A	Forward:0.39 ± 0.02(3.98 ± 0.20)[56.6 ± 2.9]	
Lubrication oil pressure, Engine at 1600 ± 100 min ⁻¹ (rpm)	MPa (kgf/cm ²)[psi]	A	Forward:0.05 ± 0.02(0.51 ± 0.20)[7.3 ± 2.9]	
Travel time for 10m starting acceleration (no load)	sec.	A	5 seconds, maximum	
Stall speed in theory		K21:1930 ± 100 min ⁻¹ (rpm)		
		K25: 2008 ± 100 min ⁻¹ (rpm)		
		S4Q2: 2550 ± 100 min ⁻¹ (rpm)		
		S4S: 2100 ± 100 min ⁻¹ (rpm)		
Pump boss	Diameter of fitting surface in contact with oil seal 1	A	42 ^{-0.085} _{-0.035} (1.654 ^{-0.0033} _{-0.0014})	
		B	41.85 (1.648)	
				
		213675		
Pilot boss	Diameter of shank 1	A	15 ^{-0.007} _{-0.042} (0.591 ^{-0.0003} _{-0.0017})	
		B	14.95 (0.589)	
				
		213676		

A: Standard value B: Repair or service limit

4. Troubleshooting

Foot Brake	Lack of braking force	Oil leaking past primary cup in master cylinder	*Replace piston cup(s) if cylinder is free from unacceptable wear. Replace the cup(s) and fluid with genuine parts if the cup(s) is distorted.
		Oil leaking past cups in wheel cylinder	
		Oil leaking from oil pipe connection	Retighten, or replace pipe and connector.
		Shoe linings worn	Replace.
		Shoe linings dirty with oil or grease	Clean or replace.
	Excessive pedal stroke	Air trapped in brake fluid lines	Bleed air at master and wheel cylinders.
		Piston cup defective in master cylinder	Replace.
		Not enough fluid in reservoir tank	Refill.
		Push rod to piston clearance too large in master cylinder	Adjust.
		Brake fluid leakage	Refer to * above.
		Automatic adjuster inoperative	Ensure that cable guide and adjusting spring are correctly installed. If still inoperative, replace cable, spring, lever and adjusting screw.
	Uneven braking (wheel brake is more effective on one side than on the other)	Lining or drum dirty with oil or grease in less effective brake	Clean with cleaner. If lining still dirty, replace.
		Wobbly or loose-mounted drum in less effective brake	Replace drum. If loose, readjust and retighten.
		Wheel tires inflated unequally	Reinflate to specification.
	Brake squeals	Lining glazed	Sand.
		Worn linings	Replace shoe and lining assemblies.
		Backing plate securing bolts loose	Retighten.
		Wheel bearings loose	Readjust preload and retighten.
		Brake drum dirty	Clean with cleaning solvent.
	Brake squeals (clicking)	Anchored ends of shoes rattling on anchor	Repair or replace.
		Shoe ledges badly worn	Replace backing plate.
		Pistons badly worn in wheel cylinder	Replace wheel cylinder.
	Abnormal noise during traveling	Lining to drum clearance too small	Adjust.
Brake drum badly distorted		Repair or replace.	
Will not apply	Linings worn to the service limit	Replace.	
	Lining to drum clearance too large	Adjust.	
Parking brake	Lever stroke is too small	Lining to drum clearance too small	Adjust.
	Will not apply	Parking brake cable longer than specification	Check lining to drum clearance. If brake will still not apply, readjust cable length.
		Lever lacks operating force	Adjust.

Unit: mm (in.)

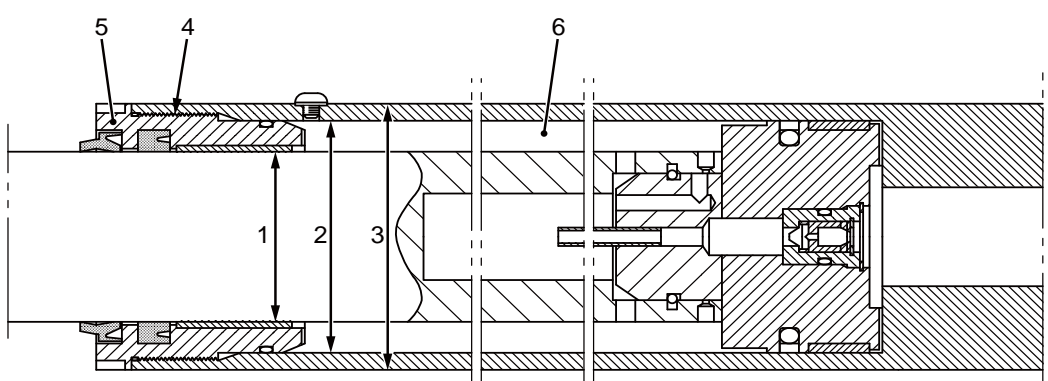
Item			Truck type			
			1 ton class	2 ton class	3 ton class	
First cylinder for duplex mast and triplex mast	Rod outside diameter 1	A	55 (2.17)	55 (2.17)	65 (2.56)	
	Cylinder inside diameter 2	A	70 (2.76)	75 (2.95)	85 (3.35)	
	Cylinder outside diameter 3	A	82 (3.23)	86 (3.39)	97(3.82)	
	Thread size of cylinder head 4	A	M75	M80	M90	
	Tightening torque of cylinder head 5	N·m (kgf·m) [lbf·ft]	A	382 (39) [282]	422±96.1 (43 ± 9.8) [311 ± 70.9]	490±113 (50 ± 12) [361 ± 83]
	Sealed-in amount of cushion oil 6	cc (cu in.)	A	75 to 85 (4.6 to 5.2)	75 to 85 (4.6 to 5.2)	90 to 100 (5.5 to 6.1)
 <p>The diagram shows a cross-section of a hydraulic cylinder. Callout 1 points to the rod diameter, callout 2 to the inner diameter, callout 3 to the outer diameter, callout 4 to the head thread, callout 5 to the head nut, and callout 6 to the cushion oil chamber. Dimensions 1, 2, and 3 are indicated by vertical arrows on the left side of the cylinder.</p>						
213853						

A: Standard value

4.2.3 Installing Mast Strips (all mast models)

(1) Measuring and adjusting clearance G2 between the mast strip and inner mast

- ◆ Maintain a clearance between the mast strip and inner mast. Insert a thickness gauge to measure clearance G2. Adjust the clearance with shims (k) to 0.1 to 0.5 mm (0.004 to 0.020 in.).

Unit: mm (in.)

Clearance G2	0.1 to 0.5 (0.004 to 0.020)
--------------	--------------------------------

◆ Adjusting method

If clearance G2 is excessive, increase the thickness of shims (k) as required.

- ◆ Check the smooth movement by moving slowly up and down the bracket.

At the factory, shims (k) are usually adjusted to 1mm (0.039 in.) for the shipment.

4.2.4 Installing second lift cylinder

(1) Install the cylinder brackets to the lift cylinders as shown in the illustration on the right.

(2) Set the lift cylinders complete with the brackets between the outer and inner masts.

(3) Install the lift cylinder rods to the inner mast as shown in the illustration. If shims (l) are used, be sure to reinstall them. Usually shims (l) are not used.

(4) Secure the lower end of each lift cylinder on outer mast with mounting bolts.

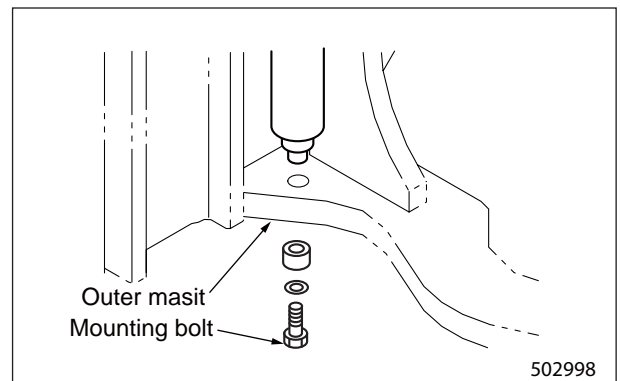
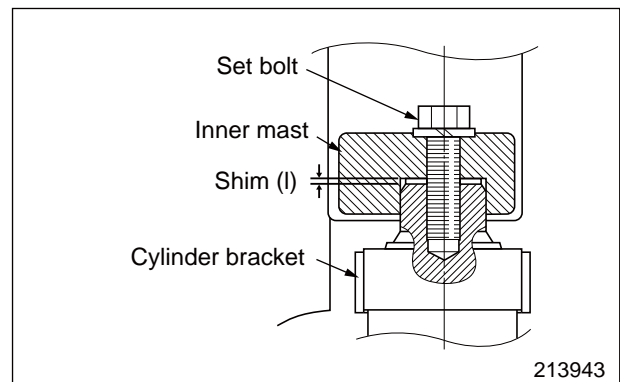
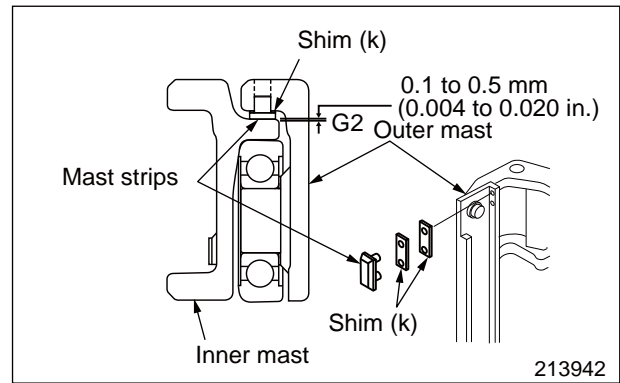

- (f) Lower the lift bracket slightly from the top so that the side roller comes in contact with the inner mast.

Measure the clearance G_1 between the side roller and inner mast. If clearance is out of specification, it is necessary to add shims to the seat of the roller bracket to adjust to correct clearance.

For adjustment and installation procedures, refer to "Adjusting clearance G_1 between the side roller and the inner mast" on (5) Adjusting clearance G_1 between the side roller and inner mast.

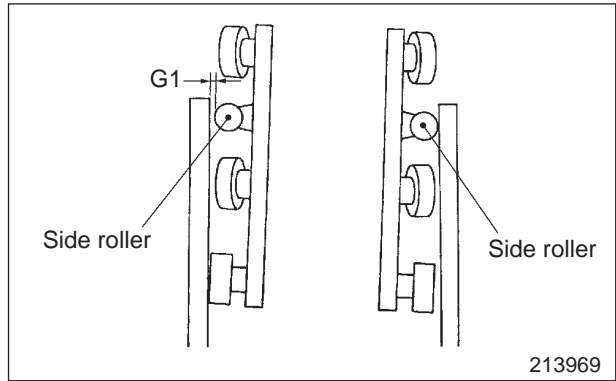

- (g) With the lift bracket at the top, check clearance G between the lower roller and inner mast. If clearance is out of specification, it is necessary to add shims to the seat of the roller to adjust to correct clearance.

For adjustment and installation procedures, refer to "Adjusting clearance G between the lower roller and inner mast" on (3) Adjusting clearance G between the lower rollers and inner mast.

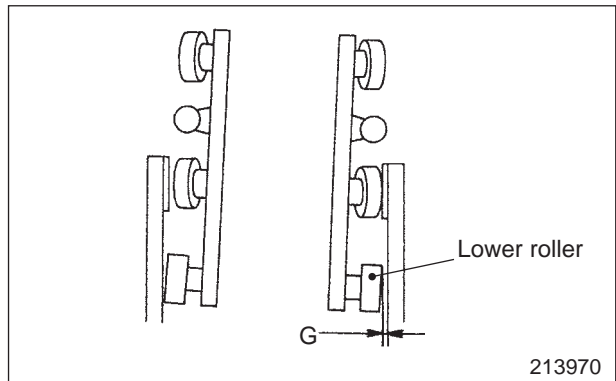

22.5 Mast Roller Clearance Adjustment

- (1) Back-to-front clearance check on mast main rollers

- (a) Tilt the mast fully backward.
- (b) Using feeler gauges, measure clearance F between the inner mast lower roller and outer mast.

Unit: mm (in.)

F	1 (0.039) maximum
-----	-------------------

- (c) If clearance is out of specification, use oversize rollers. For mast roller replacement and installation procedures, refer to "Installing mast rollers" on 12.2.2 Installing Mast Rollers.

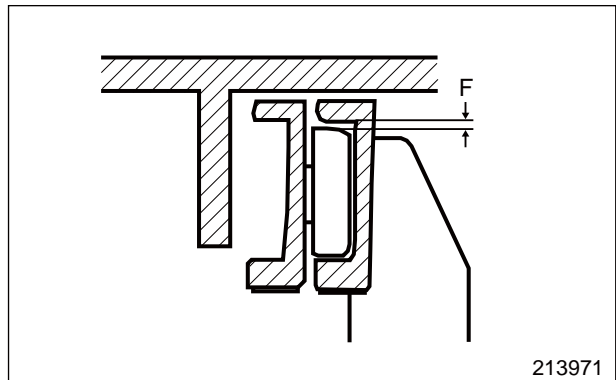

- (2) Right-to-left clearance inspection on inner mast main rollers

- (a) Raise the mast to the top.
- (b) Set a dial indicator on the inside of the outer mast with its contact point rested on the inner mast.
- (c) Go over to the opposite side of the mast, and push the inner mast against the outer mast. Set the indicator to zero (0).

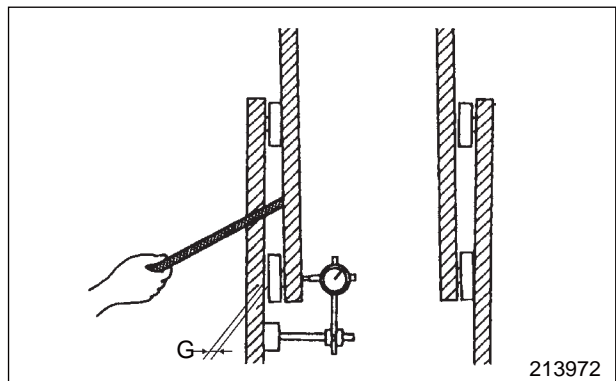

6.3 Special Service Tools (for Powershift Transmission)

Ref. No..	Part number	Name	Application	Truck type		
				1 ton class	2 ton class	3 ton class
1	67281-05100	Bolt	Removal of oil pump Removal of Idler gear bearing outer race	<input type="radio"/>	<input type="radio"/>	<input type="radio"/>
2	91268-04100	Installer	Removal of angular bearing Installation of Input spacer Installation of bearing	<input type="radio"/>	<input type="radio"/>	<input type="radio"/>
3	91268-05500	Installer	Installation of output gear oil seal	<input type="radio"/>	<input type="radio"/>	<input type="radio"/>
4	91A68-00010	Clutch pack stand kit	Disassembly and reassembly of clutch pack	<input type="radio"/>	<input type="radio"/>	<input type="radio"/>
5	91A68-00020	Stand kit	Transmission assembly fixed base	<input type="radio"/>	<input type="radio"/>	<input type="radio"/>
6	91A68-01300	Stand	Idler shaft assembly fixed base Output gear fixed base Input shaft assembly fixed base	<input type="radio"/>	<input type="radio"/>	<input type="radio"/>
7	91A68-01400	Plate 1	Compress of clutch spring	<input type="radio"/>	<input type="radio"/>	<input type="radio"/>
8	91A68-01500	Plate 2	Compress of clutch spring	<input type="radio"/>	<input type="radio"/>	<input type="radio"/>
9	91A68-01700	Installer	Installation of bushing	<input type="radio"/>	<input type="radio"/>	<input type="radio"/>
10	91A68-01800	Stand	Forward gear assembly fixed base Reverse gear assembly fixed base Oil pump assembly fixed base	<input type="radio"/>	<input type="radio"/>	<input type="radio"/>
11	91A68-01800	Puller	Removal of input spacer & bearing Removal of forward gear assembly Removal of reverse gear assembly	<input type="radio"/>	<input type="radio"/>	<input type="radio"/>
12	91A68-01900	Remover	Removal of bearing Removal of input spacer & bearing Removal of forward gear assembly Removal of reverse gear assembly	<input type="radio"/>	<input type="radio"/>	<input type="radio"/>
13	91A68-02100	Stand	Idler shaft assembly fixed base	<input type="radio"/>	<input type="radio"/>	<input type="radio"/>
14	91A68-02200	Installer	Installation of outer race	<input type="radio"/>	<input type="radio"/>	<input type="radio"/>

Weak battery	Alternator belt	Slipping	Adjust the tension.
	Alternator	Stator coil grounded or open circuit	Repair or replace.
		Rotor coil open	Replace.
		Brushes poorly seating on slip rings	Clean holder and polish slip rings.
		Brush movement defect	Adjust, replace brushes if worn.
		Diode short circuit or open circuit	Replace.
	Regulator	Regulating voltage is too low	Adjust.
	Battery	Defective or inappropriate electrolyte	Refill or adjust the S.G.
		Defective cell plates (internal short-circuit)	Replace.
		Poor terminal connections due to insufficient tightening torque	Clean and tighten.
	Wiring	Open or loose connection between the key switch and regulator IC terminal	Repair.
		Fuse blown in the above mentioned circuit or poor contact in the holder	Replace fuse or repair the holder's contact part.
		Open or loose connection between the regulator terminal F and alternator terminal F	Repair.
Battery Excessive charging	Wiring	Regulator IC and F terminals shorted or incorrectly wired	Repair.
		Defective grounding of regulator terminal F	Repair.
	Regulator	Pressure coil open circuit	Replace.
		Regulating voltage too high	Adjust.

CLICK HERE TO **DOWNLOAD** THE COMPLETE MANUAL

- Thank you very much for reading the preview of the manual.
- You can download the complete manual from: www.heydownloads.com by clicking the link below



- Please note: If there is no response to CLICKING the link, please download this PDF first and then click on it.

CLICK HERE TO **DOWNLOAD** THE COMPLETE MANUAL

Diagnosis	RI01 error (F41)
Logic conditions	CAN receiving abnormal flag from output unit _____ F41
Recovery	Recovers automatically
Action	Indication only
LED blink pattern	B

Diagnosis	RI01 PWM power error (F44)
Logic conditions	CAN receiving abnormal flag from output unit _____ F44
Recovery	Recovers automatically
Action	Indication only
LED blink pattern	B

Diagnosis	RI01 communication error (F45)
Logic conditions	CAN receiving from output unit is impractical. (100 msec continuity) _____ F45
Recovery	Recovers automatically
Action	Activates with default values of output unit incoming data.
LED blink pattern	B

Diagnosis	RI02 error (F46)
Logic conditions	CAN receiving abnormal flag from input unit _____ F46
Recovery	Recovers automatically
Action	Indication only
LED blink pattern	B

Diagnosis	RI02 communication error (F49)
Logic conditions	CAN receiving from input unit is impractical. (100 msec continuity) _____ F49
Recovery	Recovers automatically
Action	Activates with default values of output unit incoming data.
LED blink pattern	B

5.5.2 Input shaft

- (1) Inspect spline for wear and damage.
- (2) Inspect grooves A and B for wear and damage. Measure the width of grooves A and B.
- (3) Inspect oil passage C for clogging. If clogging is found, remove set screw, and clean the oil passage using compressed air.

Note: 1. If set screw is removed, apply LOCKTITE 242 to the set screw when reinstalling.

2. Be sure to use clean compressed air which is filtered through an air-filter.

Input shaft groove

Unit: mm (in.)

-	A	B
Standard Value	2.5 (0.098)	2.8 (0.110)
Repair limit	3.0 (0.118)	3.0 (0.118)

- (4) Inspect looseness between clutch drum and input shaft.

5.5.3 Gear

Inspect gear and spline for wear and damage.

5.5.4 Drum

Inspect sliding area of clutch piston for wear and damage.

5.5.5 Friction plates and mating plates

- (1) Inspect plates for seizure, local contact, deformation and damage.
- (2) Inspect spline for wear and damage.
- (3) Measure the thickness of each plate.

Note: If any of above abnormalities is found, replace all plates.

Unit: mm (in.)

Friction plate	A	2.6 ± 0.1 (0.12 ± 0.004)
	B	2.2 (0.087)
Mating plate	A	1.6 ± 0.1 (0.063 ± 0.004)
	B	1.4 (0.055)

A: Standard value B: Repair or service limit

Part name	Part number	Quantity
Friction plate	91B24-00800	10
Mating plate	91324-12601	12

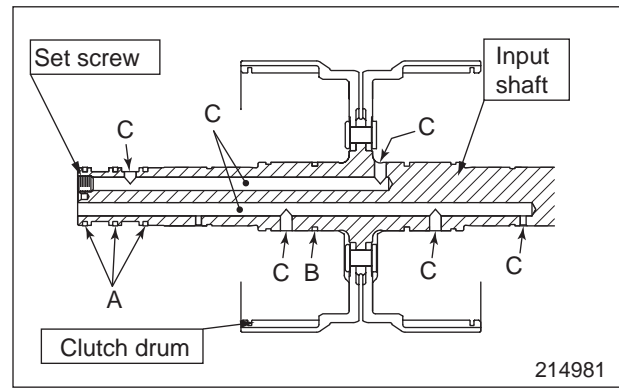

Input shaft cross-section

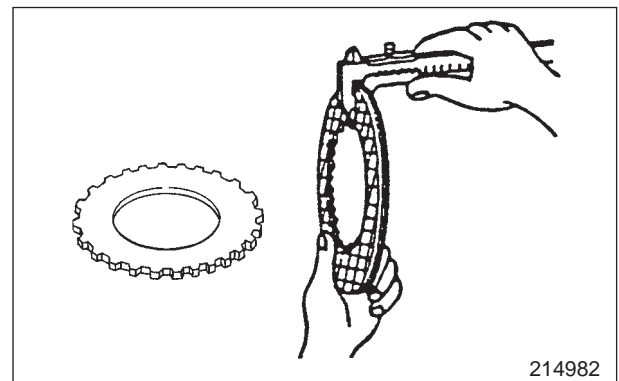

Friction plates and mating plates

2.2.2 Installation

To install, follow the removal sequence in reverse. Also follow the instructions given below.

- (1) After connecting the parking brake cable, make sure that the brake lever operating effort is within the specification.

Unit: N (kgf) [lbf]

Items	Truck type		
	1 ton class	2 ton class	3 ton class
Parking brake lever operating effort	150 to 200 (15.3 to 20.4) [34 to 45]	200 to 250 (20.4 to 25.5) [45 to 56]	230 to 250 (23.5 to 25.5) [52 to 56]

- (2) Before installing the mast, bleed trapped air in the brake fluid circuits. For bleeding, refer to "Chapter 9 BRAKE SYSTEM. "
- (3) After installing the mast, make sure that tilt angles, forward and backward, are correct and that the lift chains, right and left, are equal in tension. Refer to "Chapter 12 MAST AND FORKS."
- (4) Fill the front axle housing with oil up to the plug hole level.

Unit: liter (cu.in.)

Items	Truck type		
	1 ton class	2 ton class	3 ton class
Refill capacity of transfer and differential	5.5 (335.6)	9.3 (567.5)	8.7 (530.9)

2.3.2 Installation

Install in the following sequence.

- (1) Place the projection (a) on the steering sensor of the combination switch at the front as shown in the illustration.
- (2) Apply a light coating of grease to a sliding area of the horn contact under the steering wheel boss.
- (3) Reassemble the steering wheel in a straight-ahead position. (The projections of the combination switch fit into the pits on the steering wheel.) Completely fit the projections into the pits by turning the steering wheel in the right and left directions several times.
- (4) Before tightening the steering wheel nut, check that automatic return of the combination switch functions.
- (5) If automatic return does not function, repeat the sequence (3) and (4) above.
- (6) Tighten the steering wheel nut to the specified torque.

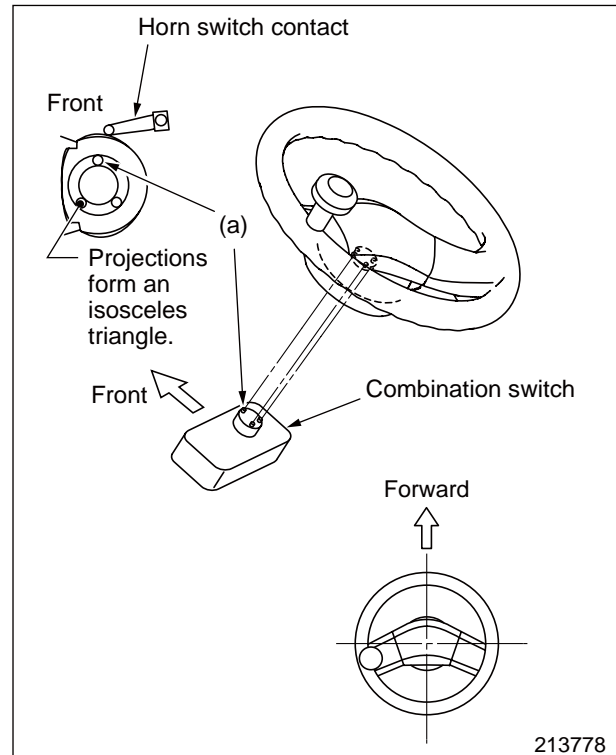

Inspection after Installation

Steering effort

- (1) Pull the hand brake lever.
- (2) Run the engine to warm the hydraulic oil to an operation temperature of 40 to 60 °C (104 to 140 °F).
- (3) Attach a spring scale to the rim (or a spoke) of the steering wheel, and measure the steering effort required to turn the steering wheel clockwise or counterclockwise from the straight-ahead position. Steering effort should be the value specified below or lower.

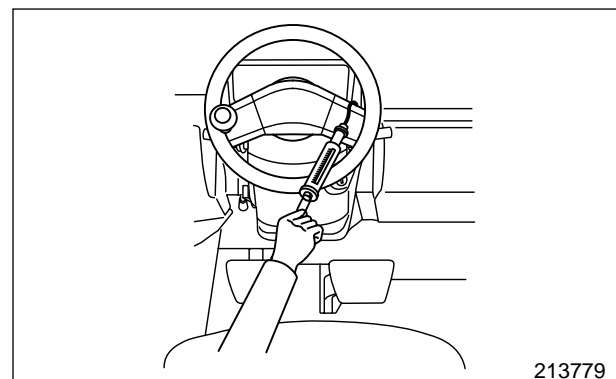

Unit: N (kgf) [lbf]

Steering effort (at steering wheel rim)	13 (1.3) [2.92]
--	-----------------------

6.1.8 Unload Valve

- 1 Solenoid valve
- 2 Valve

T1 : Tank port (return passage)

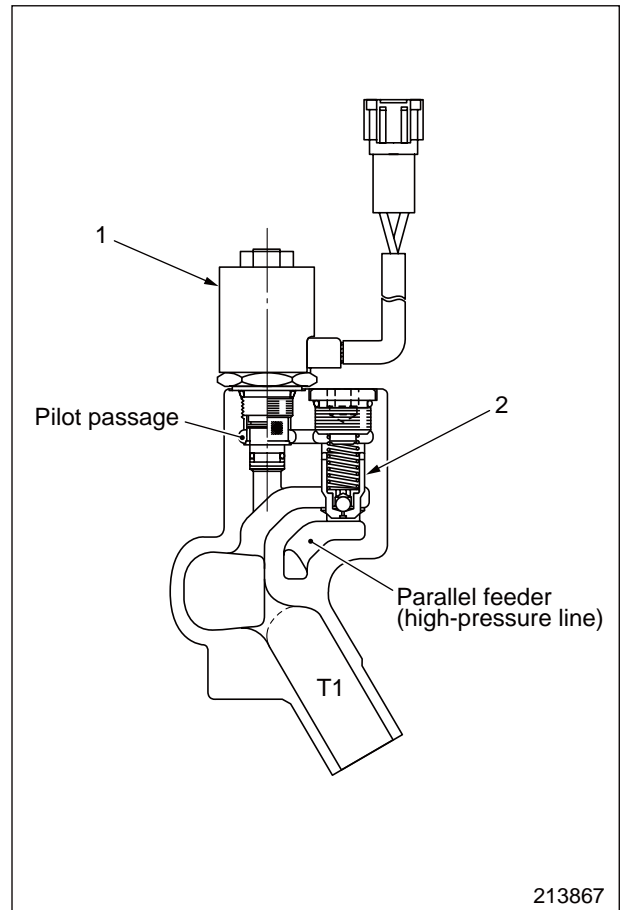

213867

The above illustration shows the unload valve when the engine stops.

When the seat switch is "open", solenoid valve 1 is open and pilot oil in the back of valve 2 is connected to the T1 passage.

Therefore, oil in the parallel feeder (high-pressure line) lightly pushes up valve 2, flowing to the T1 port.

Namely, as hydraulic pressure cannot be held, the cylinder cannot be moved even if the valve operating lever is moved.

When an operator sits on the seat, the seat switch is turned ON, actuating solenoid valve 1 to block the pilot passage. Thus, the parallel feeder can hold oil pressure.

This valve is a safety valve.

Duplex Mast Installation

To install, follow the removal sequence in reverse. Also follow the instructions given below.

(1) Mast Support

(a) Apply grease to the inner surfaces of caps and mast support bushings.

(b) 1 ton class:

When installing caps, make sure the wider chamfered side faces toward the center of the chassis.

(c) 2, 3 ton classes:

Chamfering is the same both in the right and left sides. Be sure to reassemble in the same position as it was.

(d) When applying grease, place wood blocks under the mast. By doing so, it is easily greased.

(2) Adjusting chain tension

Refer to the "Chain Tension Adjustment."

(3) Bleeding lift cylinders

In the duplex mast, the second lift cylinders are provided with air bleeding screws.

After installing the mast, start the engine, raise and lower the lift bracket with several strokes and loosen the screws to bleed.

After proper operation is confirmed, check the oil level in the hydraulic tank.

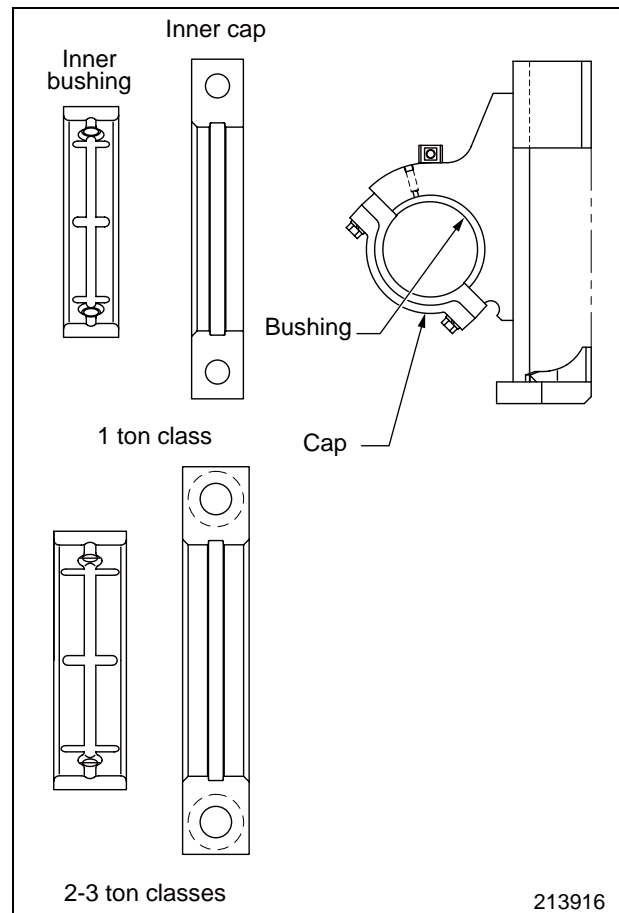

213916

2.3 Electric System

CAUTION

- ♦Be sure to conduct maintenance work on level and hard ground.
- ♦Stop the engine, and remove the starter key.
- ♦Make sure that sufficient space is available for the lift truck to move around and that no one or no obstacle is around the lift truck.

(1) Check alternator.

Service Hours	1st Month (200 hrs) only
	Every 6 months (1000 hrs)

- ♦Run the engine, and check the alternator for any unusual noise or vibration.
- ♦Check battery performance by reading specific gravity.

Note: Refer to Chapter 3, Electrical System, 4 Battery Maintenance for details.

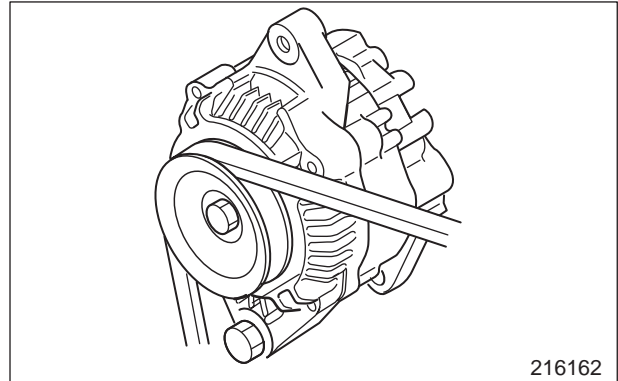

(2) Check back-up lamps.

Service Hours	Prestart (Daily/10 hrs)
---------------	-------------------------

- (a) Turn the key switch to the ON position.
- (b) Place the direction lever in the reverse.
- (c) Check that the back-up lamps turn on.

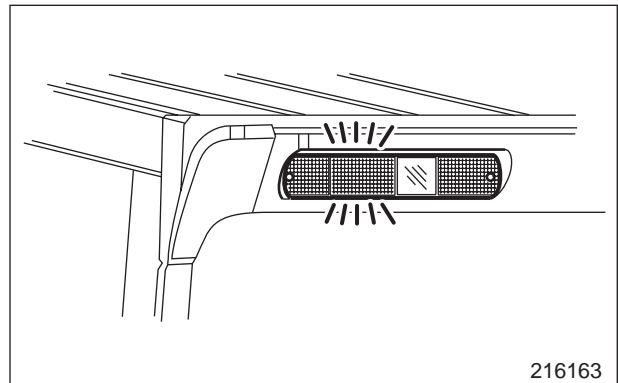

(3) Check battery. (Electrolyte level)

Service Hours	Prestart (Daily/10 hrs)
---------------	-------------------------

- ♦Check that the electrolyte level is within the specified range.

Note: Refer to Chapter 3, Electrical System, 4 Battery Maintenance for details.

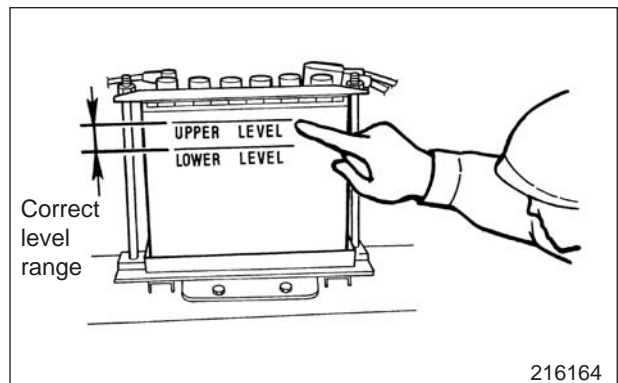

(15) Install the brake cover to the brake housing.

Tightening torque

Hexagon socket bolt	$38.1 \pm 7.6 \text{ N}\cdot\text{m}$ $(3.89 \pm 0.76 \text{ kgf}\cdot\text{m})$ $[28.12 \pm 5.61 \text{ lbf}\cdot\text{ft}]$
---------------------	---

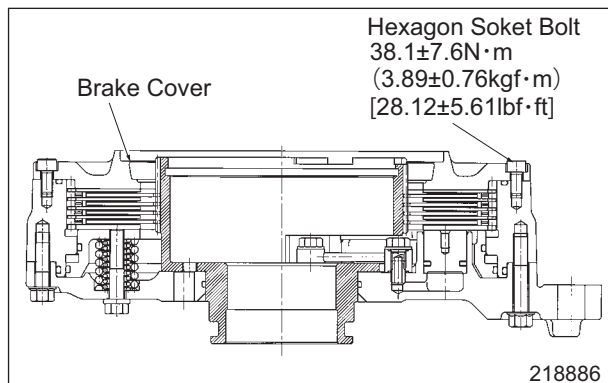

(16) Install the taper plug to the piston housing.

Tightening torque

Taper plug	$29.4 \pm 2.9 \text{ N}\cdot\text{m}$ $(3.0 \pm 0.3 \text{ kgf}\cdot\text{m})$ $[21.7 \pm 2.1 \text{ lbf}\cdot\text{ft}]$
------------	---

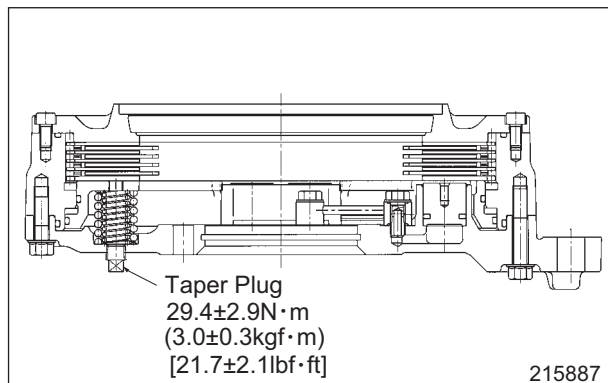

Removal and Installation

Fan Belt Removal

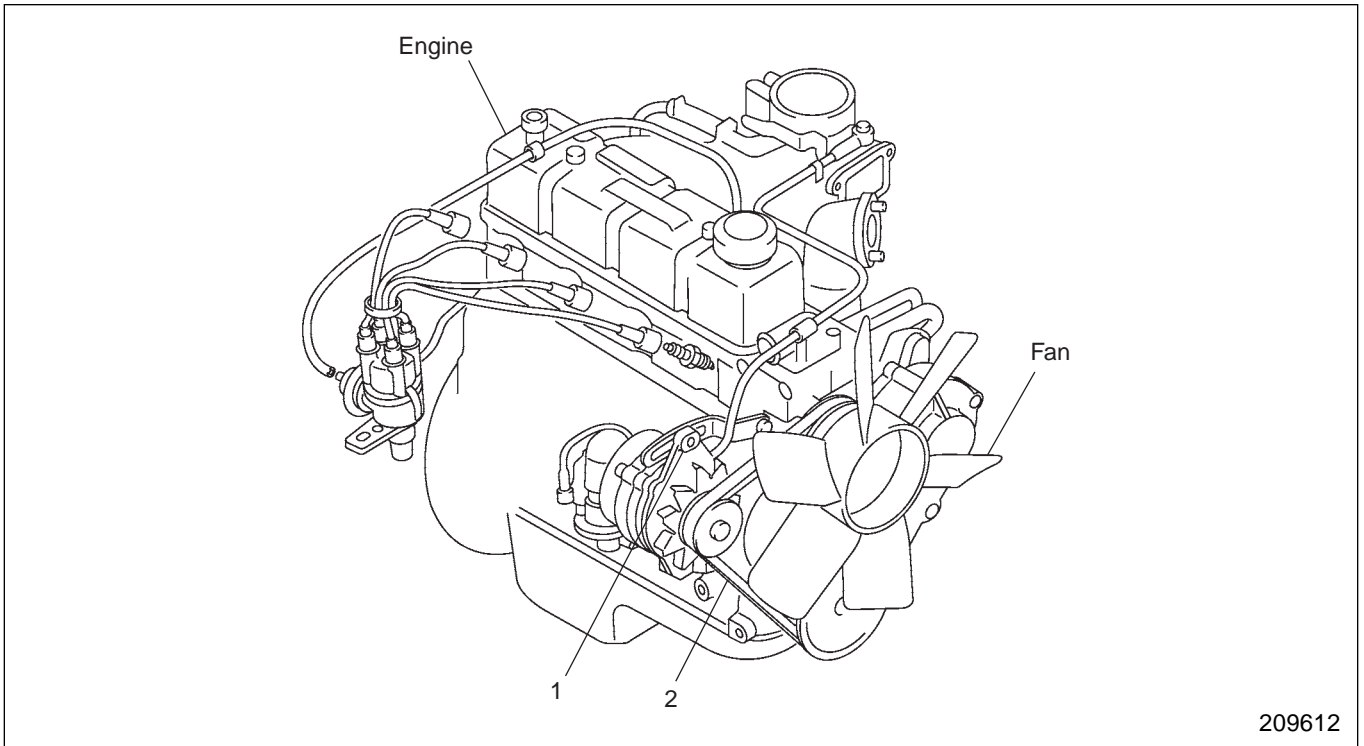

Sequence

- 1 Tension pulley assembly, Bolt
- 2 Fan belt

Start by:

Remove the radiator cover.

Suggestion for Removal

- (1) Loosen the tension pulley lock bolt by three or four turns. If the bolt is loosened insufficiently, the tension pulley will not move.

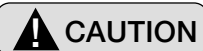

Do not loosen the lock bolt to such an extent that the bolt would be removed.

- (2) Move the tension pulley fully toward the fan, then remove the belt.

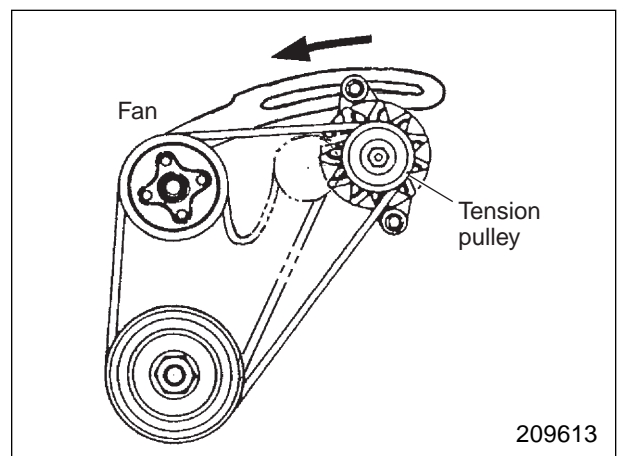

Fuse, Starter, Alternator, License Lamp

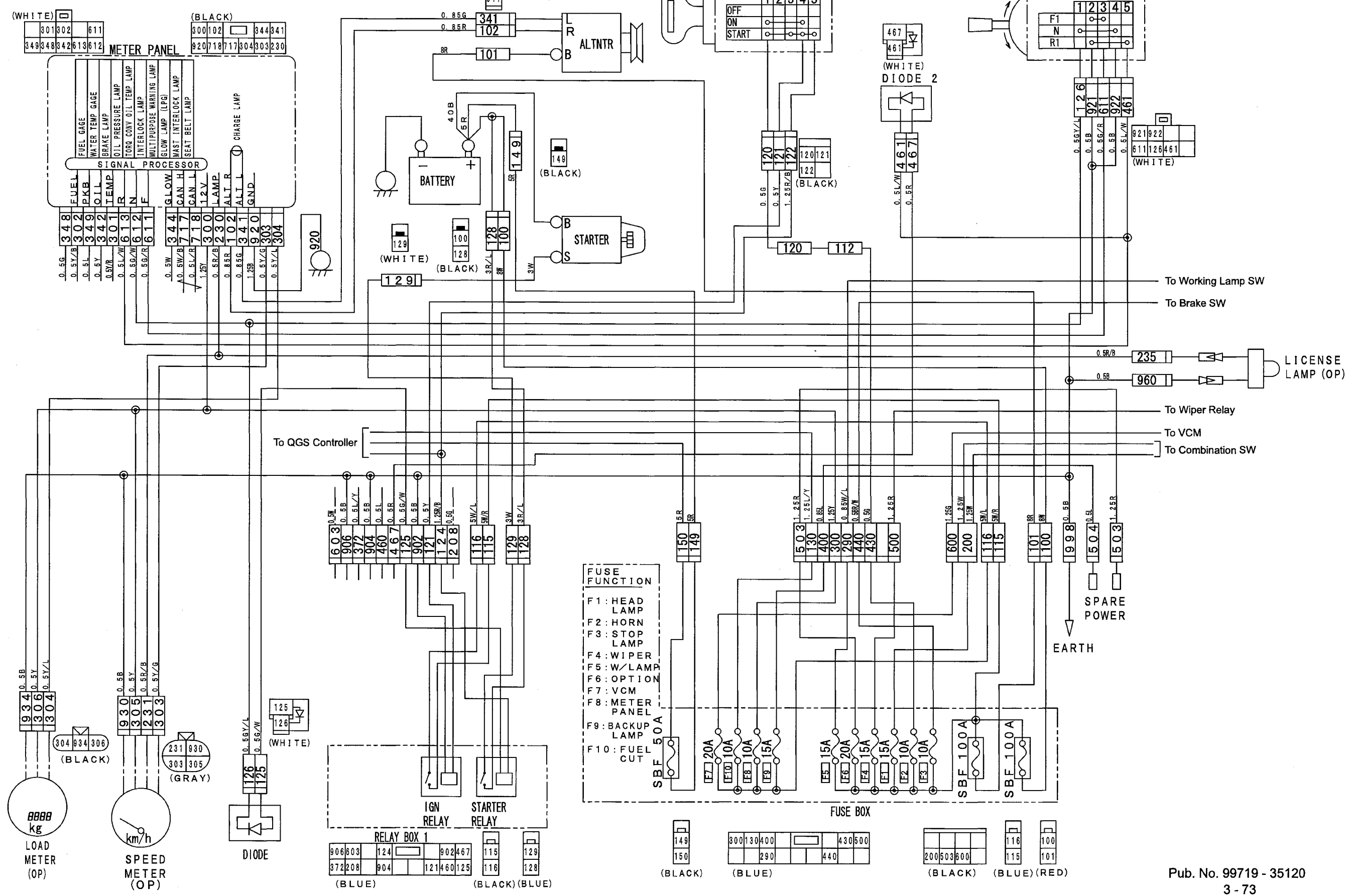

Removal and Installation (MC Models)

Removal of Engine and Transmission Assembly (for Gasoline-engine Trucks)

The engine and transmission are installed as an assembled unit. The engine may be removed independently of the transmission, but the transmission can only be removed together with the engine.

Notice: There are two types of transmission, namely the torque converter drive type (powershift transmission) and the direct drive type (manual transmission). Removal procedures vary for direct drive type transmissions according to whether they have a dry-type clutch or a wet-type clutch.

Overhead guard, covers, air cleaner and other components

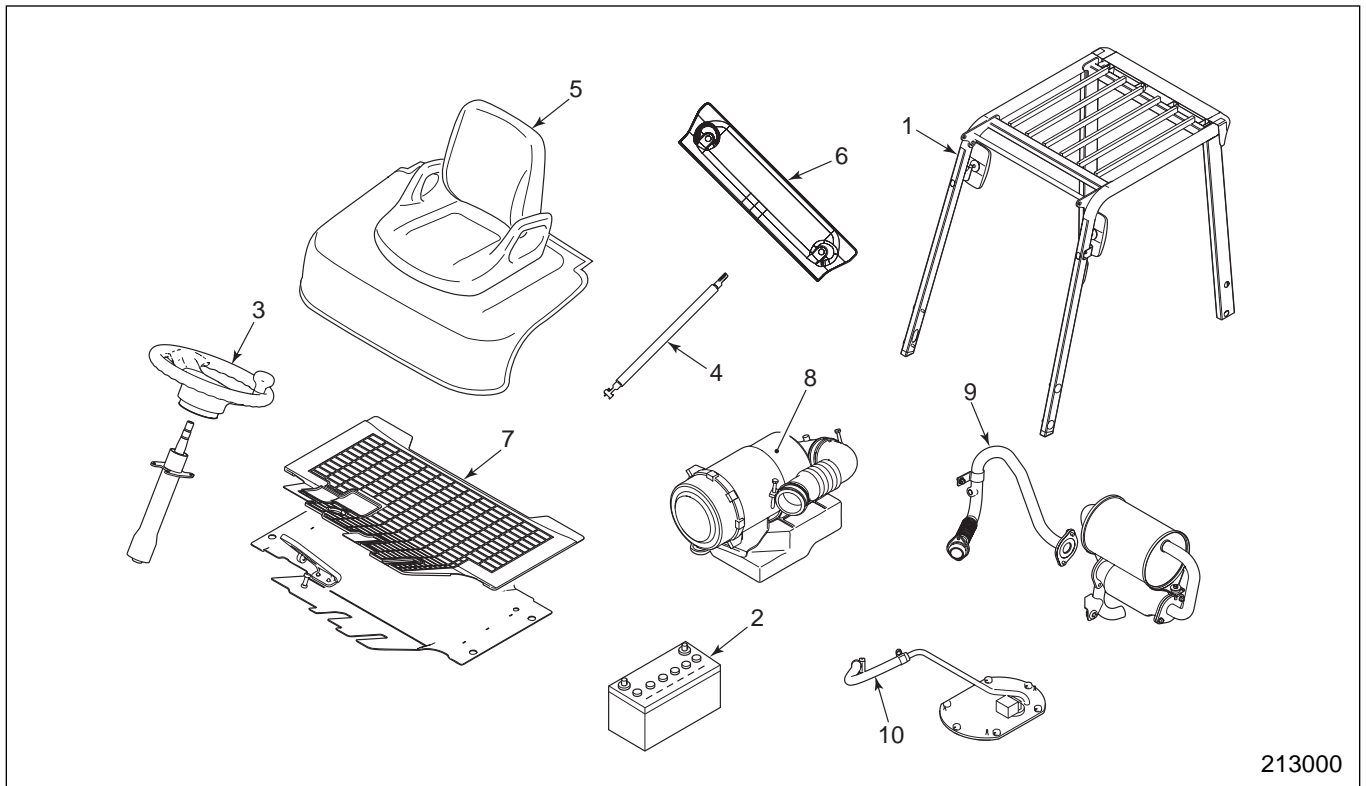

213000

Sequence

- | | | | |
|---|---------------------------|----|------------------------|
| 1 | Overhead guard, Headlamps | 6 | Radiator cover |
| 2 | Batteries, Cables | 7 | Floor plate, Floor mat |
| 3 | Steering wheel | 8 | Air hose, Air cleaner |
| 4 | Gas springs | 9 | Exhaust pipe |
| 5 | Engine cover, Seat | 10 | Fuel hoses |

Main Shaft Assembly

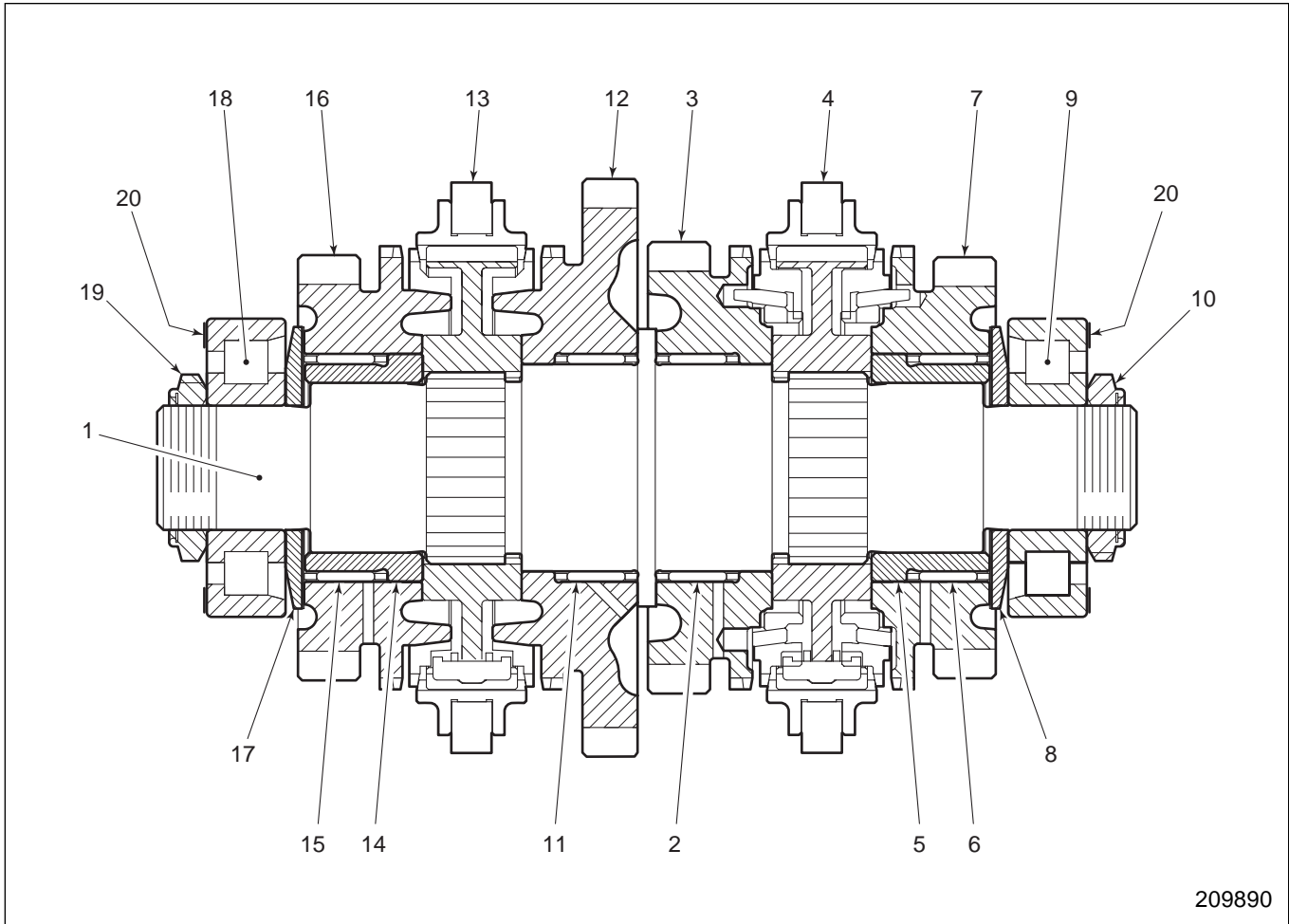

209890

Sequence

- | | | | |
|----|--------------------------------|----|--------------------------------|
| 1 | Main shaft assembly | 11 | Needle bearing |
| 2 | Needle bearing | 12 | Low gear |
| 3 | Reverse gear | 13 | Synchromesh assembly (H and L) |
| 4 | Synchromesh assembly (F and R) | 14 | Synchro gear sleeve |
| 5 | Synchro gear sleeve | 15 | Roller bearing |
| 6 | Roller bearing | 16 | High gear |
| 7 | Forward gear | 17 | Thrust washer |
| 8 | Thrust washer | 18 | Roller bearing |
| 9 | Roller bearing | 19 | Nut |
| 10 | Nut | 20 | Shim |

FRONT AXLE AND REDUCTION DIFFERENTIAL

(2) Hub bearing preload adjustment and lock nut

- (a) Install the nut hand-tight with a socket wrench (special tool).

Special tool needed

Truck Model	1 ton class	2, 3 ton classes
Item		
Socket wrench	91268 - 00800	03703 - 59001

- (b) Rotate the hub and tap its periphery with a soft-head mallet for snug assembling.
- (c) Fully tighten the lock nut to obtain hub bearing preload within the specified limits.

Notice: To check the hub bearing preload, hook a spring scale on the hub bolt, then pull it to measure the tangential force of the hub bolt.

Unit: N (kgf) [lbf]

Truck Model	1 ton class	2, 3 ton classes
Item		
Tangential force of hub bolt (increment from when preload is zero)	5.6 to 56 (0.6 to 5.7) [1.2 to 12.5]	4.5 to 45 (0.5 to 4.6) [1.0 to 10.1]
Starting torque of hub rotation (increment from when preload is zero)	0.5 to 4.9 N·m (0.05 to 0.5 kgf·m) [0.35 to 3.7 lbf·ft]	

- (d) Fit the lock ring into place and tighten the lock bolt.
- (e) Check the preload again.
- (3) Drain plug
- (a) Tighten the drain plug to the specified torque.

Tightening torque	127.5 ± 9.8 N·m (13.0 ± 1.0 kgf·m) [94.0 ± 7.2 lbf·ft]
-------------------	--

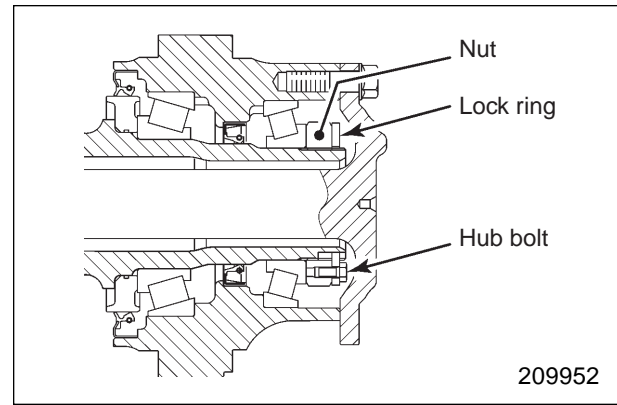

HYDRAULIC SYSTEM

Structure and Functions	13 – 1
Outline	13 – 1
Hydraulic Circuit Diagram (for trucks with MC control valve)	13 – 2
Hydraulic Circuit Diagram (for trucks with FC control valve)	13 – 3
Hydraulic Tank	13 – 4
Hydraulic Pump (Gear Pump)	13 – 5
Control Valve	13 – 6
Flow Regulator Valve (for trucks fitted with FC control valve only)	13 – 7
Down Safety Valve	13 – 7
Lift Cylinder	13 – 8
Tilt Cylinder	13 – 14
Disassembly and Reassembly	13 – 15
Hydraulic Pump	13 – 15
Removal and Installation	13 – 15
Disassembly and Reassembly	13 – 16
Lift cylinder	13 – 18
Removal and Installation	13 – 18
Disassembly and Reassembly	13 – 24
Tilt cylinder	13 – 27
Removal and Installation	13 – 27
Disassembly and Reassembly	13 – 28
Flow regulator valve	13 – 30
Disassembly and Reassembly	13 – 30
Piping	13 – 31
Suction Strainer and Return Filter	13 – 32

Main Relief Valve, Pilot Relief Valve and Unloader Valve

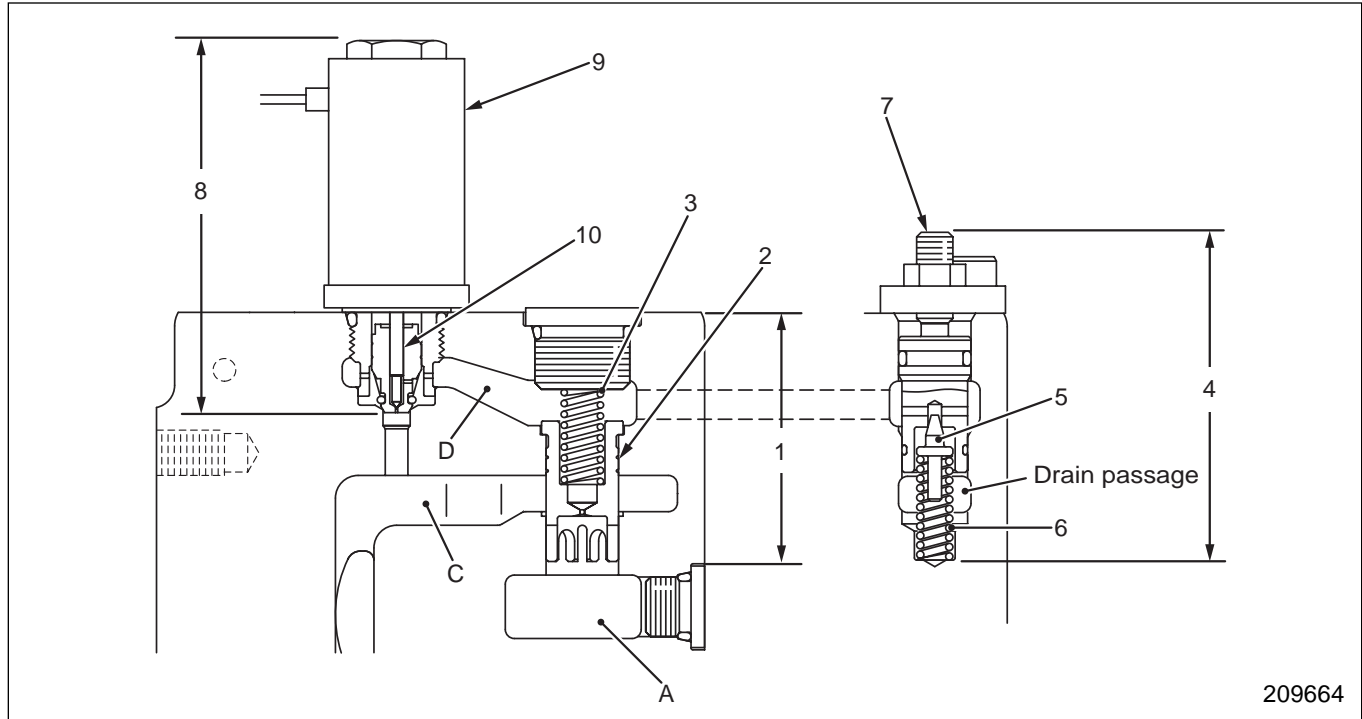

- | | | |
|----------------------|----------------------------|---------------------------------|
| 1 Main relief valve | 6 Spring | A: Extra flow (EF flow) passage |
| 2 Dump valve | 7 Pressure adjusting screw | C: Drain passage |
| 3 Spring | 8 Unloader valve | D: Oil passage |
| 4 Pilot relief valve | 9 Solenoid | |
| 5 Poppet valve | 10 Needle valve | |

Function of Component Valves

The pilot relief valve 4 and unloader valve 8 are arranged in parallel to serve as pilot valves for the main relief valve 1. To be more specific, when either valve 4 or 8 opens, the dump valve 2 overcomes the force of the spring 3 to lift, releasing high pressure oil in the oil passage A into the drain passage C.

Pilot Relief Valve 4

This is a pilot valve for the main relief valve. When pressure in the system exceeds the specified limit, the poppet valve 5 overcomes the force of the spring 6 to move downward, releasing oil in the back of the dump valve 2 into the drain passage. As a result, the dump valve of the main relief valve lifts to release some of EF flow into the drain passage.

The screw 7 is for set pressure adjustment. Tightening it clockwise increases set pressure. For set pressure and setting procedure, refer to “Inspection and Adjustment.”

Unloader Valve

The unloader valve 8, located between the back of the dump valve 2 and an oil passage connecting to the drain passage C as shown in the illustration, is a solenoid valve serving as a pilot relief valve for the main relief valve 1. When the solenoid is energized by electric current that flows through it, the needle valve 10 protrudes to close the oil passage D. When the solenoid is not energized, it has the needle valve 10 retracted in it. Therefore, the oil passage D is open.

When the operator leaves the seat and the cargo handling levers are in the neutral position, the solenoid is not activated and oil in the passage D is released into the drain passage C. This causes the dump valve 2 of the main relief valve to lift, releasing all extra flow of oil into the drain passage C. This valve thus ensures safety and helps save engine output.

When the operator moves a cargo-handling lever, the solenoid 9 is energized. The needle valve 10 protrudes to close the oil passage D, making the entire extra flow line (including pilot oil for proportional electromagnetic pressure reducing valve) ready to work normally.

Installation of a fitting with straight threads and O-ring seal

1. Apply grease or hydraulic oil to the O-ring and O-ring seat in the housing side.
2. Turn lock nut 3 to move it as close to fitting body 2 as possible. Place washer 4 and O-ring seal 5 against the lock nut.
3. Tighten the fitting by hand. Once O-ring seal 5 is placed in the position of housing and washer 4 comes in contact with the surface of housing, turn it back to adjust the mounting direction. Never loosen more than 1 turn.
4. Tighten lock nut 3 to the specified torque.

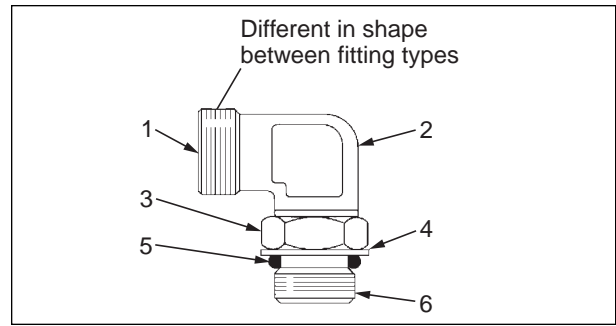

Elbow body assembly

- | | |
|--|--|
| 1 End of fitting body (connects to tube) | 4 Backup washer |
| 2 Fitting body | 5 O-ring seal |
| 3 Lock nut | 6 End of fitting that goes into other part |

SAFETY



WARNING

The proper and safe lubrication and maintenance for these lift trucks, recommended by Mitsubishi Forklift Trucks, are outlined in the **OPERATION & MAINTENANCE MANUAL**.

Read and understand the OPERATION & MAINTENANCE MANUAL before performing any lubrication or maintenance on these trucks.

Improper performance of lubrication or maintenance procedures is dangerous and could result in injury or death.

The serviceman or mechanic may be unfamiliar with many of the systems on this truck. This makes it important to use caution when performing service work. A knowledge of the system and/or components is important before the removal or disassembly of any component.

Because of the size of some of the truck components, the serviceman or mechanic should check the weights noted in this Manual. Use proper lifting procedures when removing any components.

Following is a list of basic precautions that should always be observed.

- (1) Read and understand all warning plates and decals on the truck before operating, lubricating or repairing the product.
- (2) Always wear protective glasses and protective shoes when working around trucks. In particular, wear protective glasses when using a hammer or sledge on any part of the truck or its attachments with a hammer or sledge. Use welders gloves, hood/goggles, apron and other protective clothing appropriate to the welding job being performed. Do not wear loose fitting or torn clothing. Remove all rings from fingers when working on machinery.
- (3) Do not work on any truck that is supported only by lift jacks or a hoist. Always use blocks or jack stands to support the truck before performing any disassembly.
- (4) Lower the forks or other implements to the ground before performing any work on the truck. If this cannot be done, make sure the forks or other implements are blocked correctly to prevent them from dropping unexpectedly.



WARNING

Do not operate these trucks unless you have read and understood the instructions in the OPERATION & MAINTENANCE MANUAL. Improper truck operation is dangerous and could result in injury or death.

- (5) Use steps and grab handles (if applicable) when mounting or dismounting a truck. Clean any mud or debris from steps, walkways or work platforms before using. Always face truck when using steps, ladders and walkways. When it is not possible to use the designed access system, provide ladders, scaffolds, or work platforms to perform safe repair operations.
- (6) To avoid back injury, use a hoist when lifting components which weigh 23 kg or more. Make sure all chains, hooks, slings, etc., are in good condition and are of the correct capacity. Be sure hooks are positioned correctly. Lifting eyes are not to be side loaded during a lifting operation.
- (7) To avoid burns, be alert of the hot sections and hot fluids in lines, tubes and compartments, even when idle or off.
- (8) Be careful when removing cover plates. Gradually remove the last two bolts or nuts located at opposite ends of the cover or device and pry cover loose to relieve any springs or other pressures, before removing the last two bolts or nuts completely.
- (9) Be careful when removing filler caps, breathers and plugs on the truck. Hold a rag over the cap or plug to prevent being sprayed or splashed by liquids under pressure. Be aware that the danger of being sprayed or splashed is even greater if the truck has just been stopped because fluids can be hot.
- (10) Always use tools that are in good condition and be sure you understand how to use them before performing any service work.
- (11) Reinstall all fasteners with same part number. Do not use a lesser quality fastener if replacements are necessary.
- (12) If possible, make all repairs with the truck parked on a level, hard surface. Block truck so it does not roll while working on or under truck.

6. Wire Color

Wire colors listed in the table below show standard colors (base colors). For wiring composed of two colors, the first color shows a base color and the second color a marking color.

Example: The wire color of B/W shows that its base color is B with a marking W.

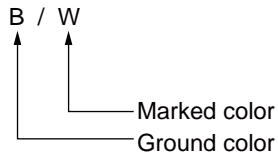

Note: For wiring identification, the same color, in principle, must be used for the circuit from the power supply to the load.

⚠ CAUTION

Be careful that allowable current differs between solid wires and stranded wires even if they are of the same gauge.

6.1 List of Wire Colors

Wire color	Color
B	BLACK
W	WHITE
R	RED
G	GREEN
Y	YELLOW
BR	BROWN
L	BLUE
LG	LIGHT GREEN
OR	ORANGE
P	PINK
GY	GRAY
SB	LIGHT BLUE
PU	PURPLE

CONTROLLERS

Diagnosis	Sensor battery error (F31)
Logic conditions	Sensor battery is 2.5V or less (20-millisecond continuity)  F31
Recovery	Turn on power again.
Action	Photoelectronic sensor: keeps the status before error occurs. 12V DC power: not considered as an error. Wheel angle sensor: No knob deviation correction control by not considering as an error. Tilt angle sensor, Oil pressure sensor [lift]: No tilt auto-stop control by not considering as an error. Speed sensor: not considered as an error. Speed value is effective. No error detection in current break, short or leaks of solenoid [unload/lift lock], T/M control valve [F/R], Knob position solenoid/tilt lock solenoid. (Solenoid outputs remains the status before error occurs.)
LED blink pattern	B

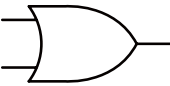
Diagnosis	Oil pressure sensor (lift) error (F32)
Logic conditions	Input signal is 0.1V or less Input signal is 4.9V or more (400-millisecond continuity)  F32
Recovery	Turn on power again.
Action	No tilt action with the load indication OFF and the tilt auto-stop SW ON.
LED blink pattern	D

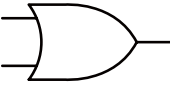
Diagnosis	Speed sensor error (F34)
Logic conditions	Input signal is 1.3V or less Input signal is 4.9V or more (400-millisecond continuity)  F34
Recovery	Turn on power again.
Action	With T/M shift lock control, neglect of speed. On the lift trucks with ECM, maximum speed limit value plus 1km/h is transmitted. On non-electric control engine, 0km/h is transmitted.
LED blink pattern	D

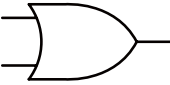
Diagnosis	Wheel sensor error (F36)
Logic conditions	Input signal is 0.27V or less (10 degrees) Input signal is 4.72V or more (170 degrees) (400-millisecond continuity)  F36
Recovery	Turn on power again.
Action	No knob deviation correction control
LED blink pattern	D

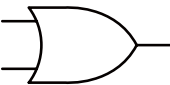
Diagnosis	Wheel sensor error (F38)
Logic conditions	Input signal is 0.1V or less Input signal is 4.9V or more (400-millisecond continuity)  F38
Recovery	Turn on power again.
Action	No tilt action with the tilt auto-stop ON.
LED blink pattern	D

4. Adjustment

4.1 Bleeding Clutch Hydraulic System

Bleeding the hydraulic system of the clutch is a two-man operation. Start the engine, then proceed to bleed the system with the engine idling.

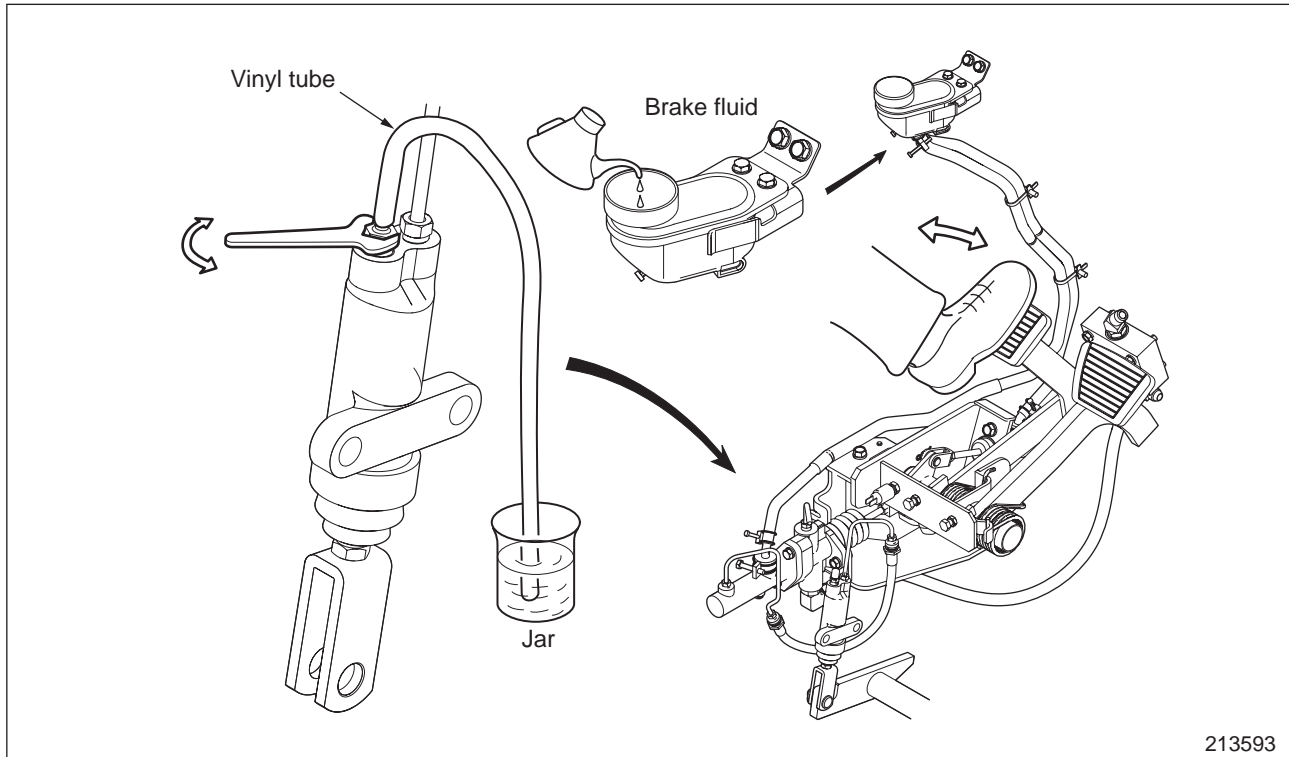

213593

- (1) Fill the reservoir with brake fluid. Keep the reservoir more than half full of fluid during bleeding operation.
- (2) Remove the bleeder cap. Connect one end of a transparent vinyl tube (6mm in inside diameter) to the bleeder valve. Place the other end of the tube into a transparent jar filled with brake fluid. (Be sure that the tube is in the fluid.)
- (3) One person slowly pumps the clutch pedal full stroke several times. Hold the clutch pedal down after depressing for the last time.
- (4) The other person loosens the bleeder valve with a wrench (10 mm (0.40 in.)). This causes the brake fluid in the system to flow out with trapped air into the jar.
- (5) Tighten the bleeder valve and slowly remove foot pressure from the clutch pedal.
- (6) Repeat the steps (3), (4) and (5) until no more air bubbles are seen in the jar.
- (7) Reinstall the bleeder cap and refill the reservoir with the brake fluid up to the specified level.

Precautions

- (1) Maintain the proper fluid level in the reservoir during bleeding operation.
- (2) Use care not to spill brake fluid on painted surfaces.
- (3) When refilling the reservoir, do not mix different types of brake fluid.
- (4) Connect the vinyl tube liquid-tight.
- (5) After bleeding, refill the reservoir slowly up to the specified liquid level.
- (6) Release the clutch pedal slowly. If not, air could be drawn back into the system.
- (7) Do not remove foot pressure from the clutch pedal before tightening the bleeder valve.
- (8) Do not reuse the brake fluid in the jar. It may contain foreign substances like dirt.

5. Powershift Transmission, Reassembly

5.1 Transmission Housing, Reassembly

5.1.1 Output gear oil seal, Installation

- (1) With Servo case mounting surface facing upward, place transmission housing on wooden blocks.
- (2) Using the special tool (installer, 91268-05500), install output gear oil seal.

Part name	Part number	Quantity
Oil seal	91A24-08600	1

Part name	Part number
Installer	91268-05500



214973

5.2 Torque Converter Housing, Reassembly 1

5.2.1 Torque converter relief plate and relief cover, Installation

Install torque converter relief plate and relief cover.

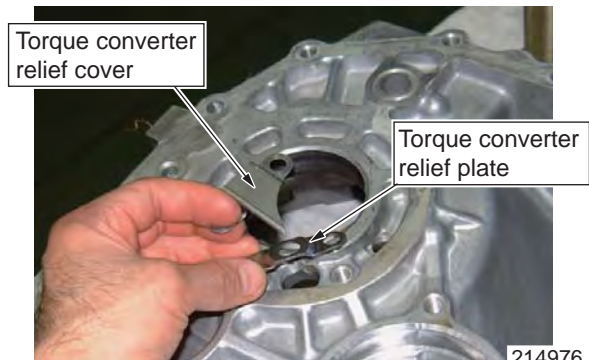

214976

5.2.2 Baffle plate, Installation

Install baffle plate using 2 bolts.



214977

Suggestions for Removal

In the case of double wheels, remove the outer wheel nuts and outer wheel. Then, remove the inner wheel nuts and inner wheel.

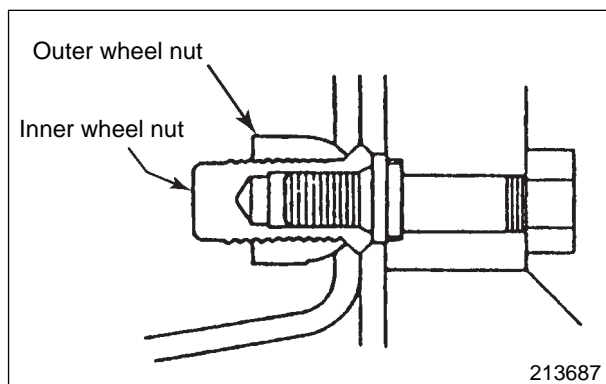

2.1.2 Installation

To install, follow the removal sequence in reverse. Also follow the instructions given below.

- (1) Tighten the wheel nuts evenly to the specified torque so that the wheels will not wobble during operation.

Unit: N·m (kgf·m) [lbf·ft]

Items	Truck type	
	1 ton class	2 ton class 3 ton class
Tightening torque	156.9 ± 15.7 (16.00 ± 1.601) [115.7 ± 11.58]	377.8 ± 37.8 (38.5 ± 3.855) [279.00 ± 27.88]

1.4 Steering Column

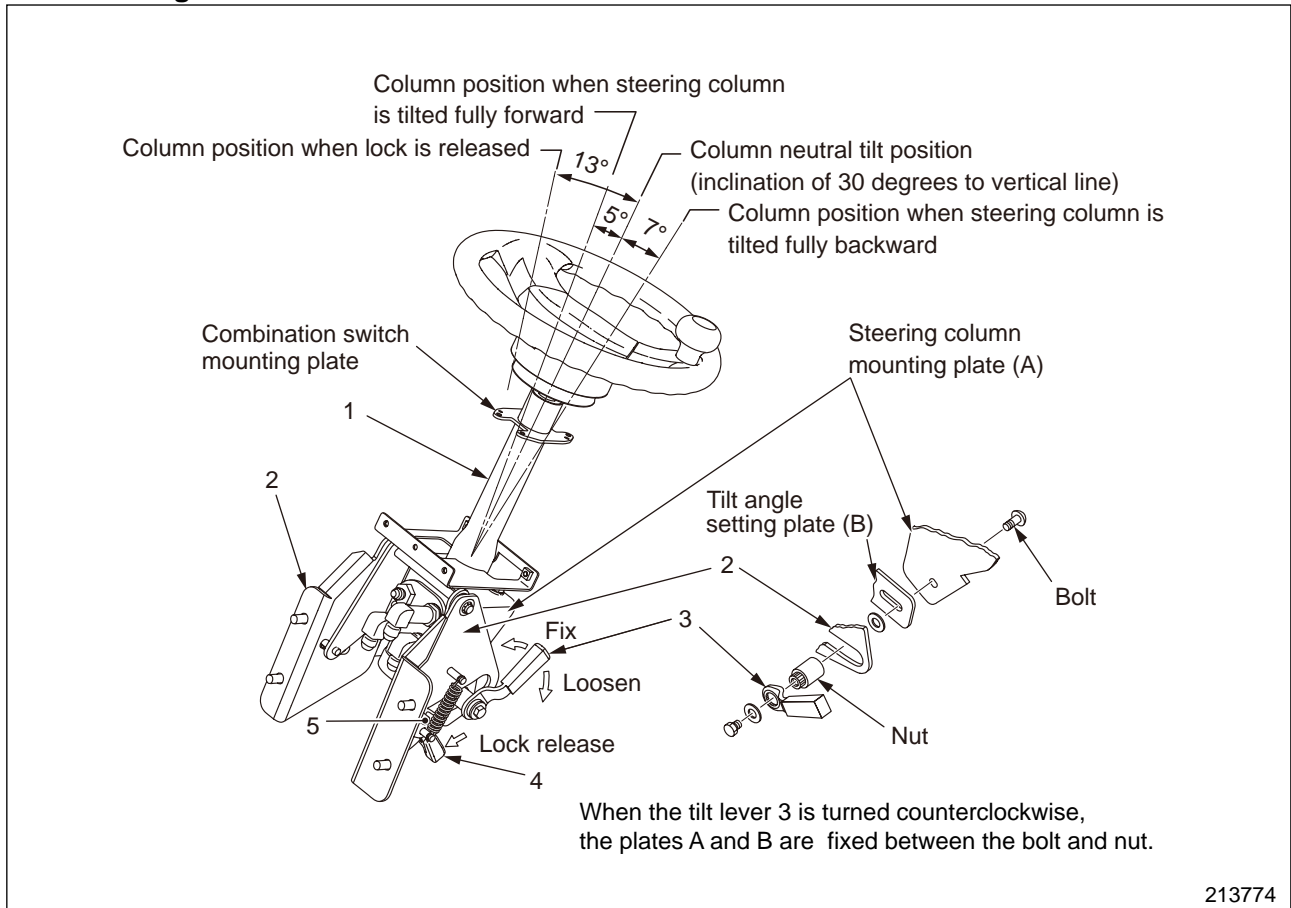

Main Components

- 1 Steering Column
- 2 Bracket (secured to truck body)
- 3 Tilt lock lever
- 4 Column lock lever
- 5 Lock pin

The steering column tilt angle is adjustable in the range of 5 degrees forward and 7 degrees backward as shown in the illustration.

To adjust the tilt angle, lock the column lock lever 4 first, and loosen the tilt lock lever 3 by turning it clockwise. Then, tilt the steering column 1 to the optimal angle and turn the tilt lock lever counterclockwise (pulling upward) to lock.

The column lock lever 4 is used to tilt the steering column forward for the convenience of the operator to get on and off the lift truck and during maintenance. Tilt the steering column forward by pushing down the tilt lock lever 3 to disengage the column lock lever 4 from the lock pin 5.

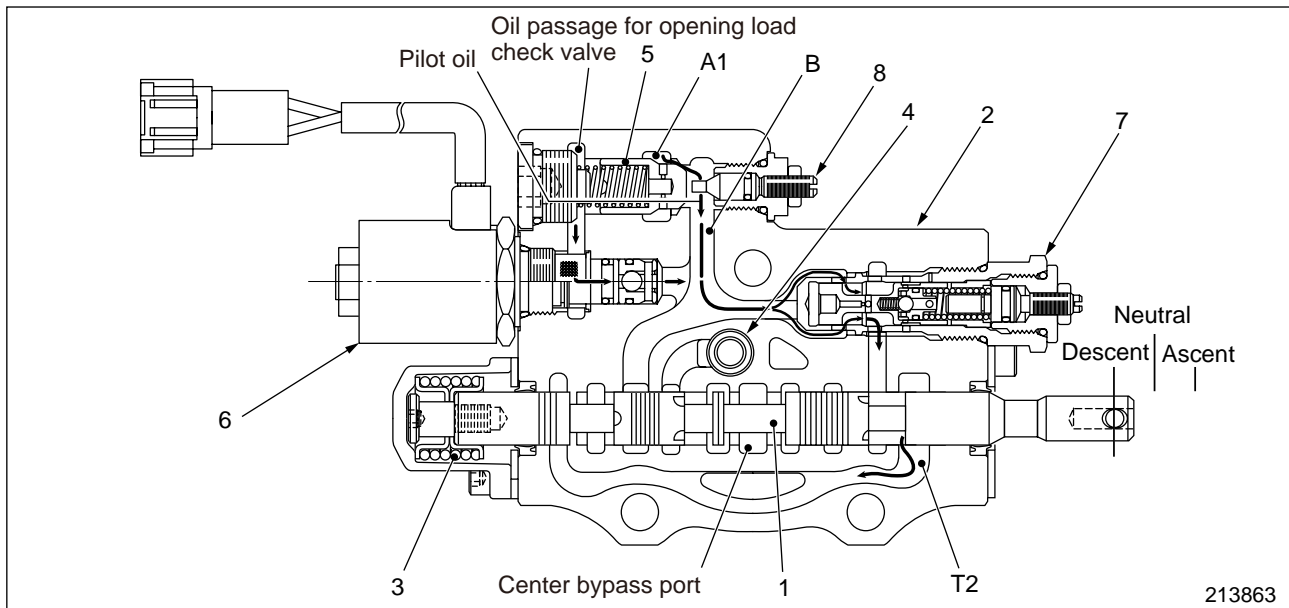

Descending position of lift cylinder :

The above illustration shows the lift control valve when spool 1 is at "descending position."

Spool 1, pushed in body 2, is at the position as shown in the illustration. The center bypass port is not blocked. The secondary port of flow regulator valve 7 is open to the T2 port (return passage).

When an operator sits on the seat, Vehicle Control Module (VCM1-M) detects it, making an electric current flow to solenoid valve 6 to activate the solenoid.

When the solenoid activates, pilot oil behind load check valve 5 is released to the passage B. Thus, load check valve 5 moves to the left (in the illustration) by pressure of the A1 port and oil in the A1 port flows to the T2 port via flow regulator valve 7.

Shut-off valve 8 forcibly opens load check valve 5 if the load check valve does not automatically activate due to malfunction of solenoid 6 or any other reason. Just loosen the lock nut and push in the screw.

Action of flow regulator valve

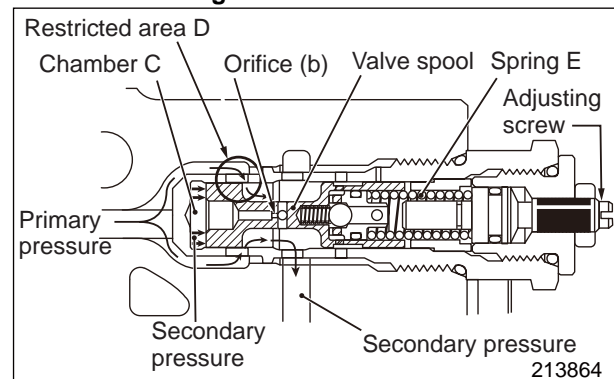

The flow regulator valve keeps the maximum speed constant during cylinder descent regardless of the load weight on the fork.

Oil from the A1 port (primary pressure) passes through the restricted area D and its pressure is reduced. This pressure-reduced oil (secondary pressure) flows to chamber C through the orifice (b) and moves the valve spool to the right against the spring E, restricted area D. The degree of this restriction is greater as the primary pressure is higher. Thus, the secondary pressure is made constant. If the secondary pressure is constant, the outflow volume is constant.

The right part of this valve is a mechanism to stabilize valve spool movement. Do not adjust this valve in field.

10. Structure and Functions

10.1 Duplex Mast (Dual Full-Free Panoramic 5F15C to 5F35C)

Notice: For hydraulic lines, refer to "12.2.7 Installing Hydraulic Lines."

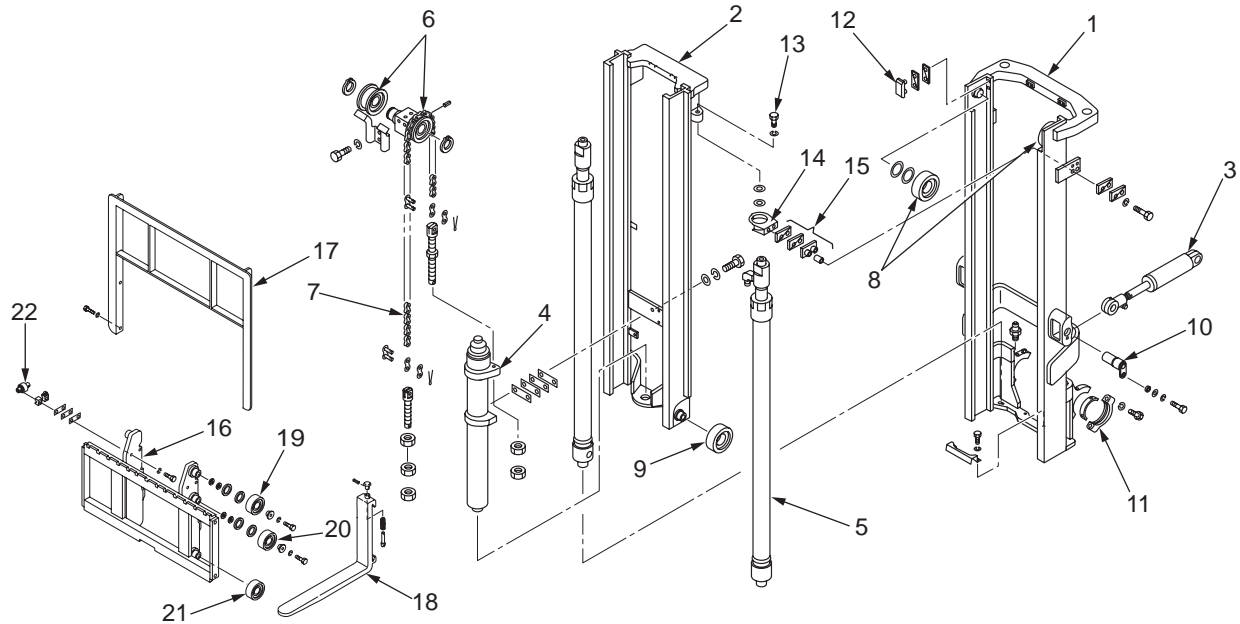

214833

Major Components (most parts come in pairs, left and right)

- | | | |
|-----------------------------|---------------------------------------|-------------------------------|
| 1 Outer mast | 9 Inner mast roller | 17 Backrest |
| 2 Inner mast | 10 Tilt socket mounting pin | 18 Forks |
| 3 Tilt cylinder | 11 Mast support cap | 19 Lift bracket upper roller |
| 4 First lift cylinder (one) | 12 Mast strip | 20 Lift bracket middle roller |
| 5 Second lift cylinder | 13 Lift cylinder upper mounting bolts | 21 Lift bracket lower roller |
| 6 Chain wheel | 14 Cylinder bracket | 22 Side roller |
| 7 Chain | 15 Cylinder clamps | |
| 8 Outer mast roller | 16 Lift bracket | |

In the duplex mast, the first cylinder raises the forks without increasing the overall mast height (free-lift) until the upper edge of the backrest exceeds the top of the mast.

The mast assembly consists of the inner mast, outer mast, lift bracket, first lift cylinder and second lift cylinders.

The first lift cylinder raises the lift bracket, while the second cylinders operate the inner mast and lift bracket.

The first cylinder is equipped with the upstroke cushioning including internal drain and the second cylinder equipped with the down cushioning.

For mast operation, refer to "Mast Operation" on 10.2 Mast Operation.

2. Maintenance Note

2.1 Brake System

CAUTION

- ♦ Be sure to conduct maintenance work on level and hard ground.
- ♦ Stop the engine, and remove the starter key.
- ♦ Make sure that sufficient space is available for the lift truck to move around and that no one or no obstacle is around the lift truck.

(1) Check brake drum bolts.

Service Hours	Every 3 months (500 hrs)
---------------	--------------------------

- ♦ Check the threads for damage or burrs.

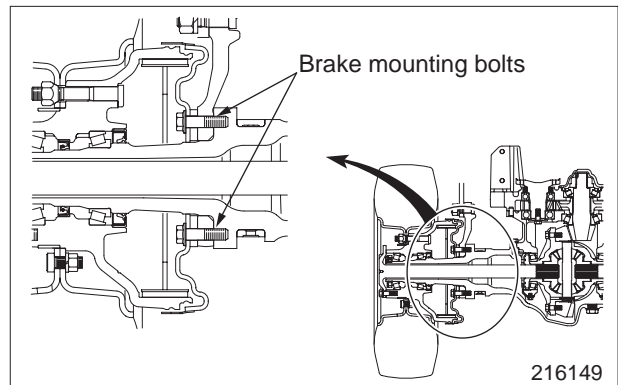

(2) Check brake drum and shoes.

Service Hours	Every 3 months (500 hrs)
---------------	--------------------------

- ♦ Check the drum inner surface for uneven wear or scratches.
- ♦ Check shoes and lining for cracks or damage.
- ♦ If oil contamination or deformation is found, replace the brake lining with a new one.
- ♦ Measure the brake lining thickness. If the lining thickness exceeds a service limit, replace the lining with a new one.

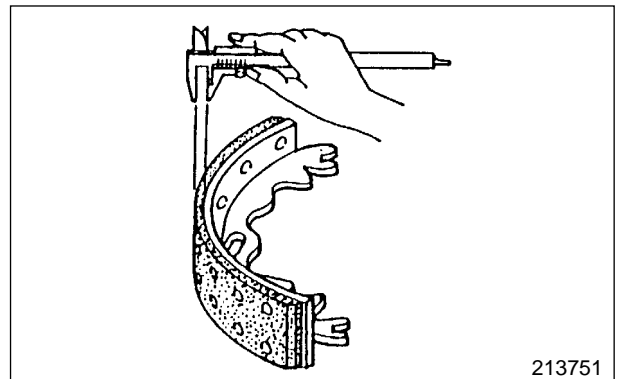

Unit: mm (in.)

Items		Weight class	
		1 ton class	2 ton class 3 ton class
Thickness of linings	A	4.87 (0.19)	5.7 (0.22)
	B	1.0 (0.04)	

Note: Refer to Chapter 11 BRAKE SYSTEM, 2.2 Wheel Brakes for details.

Gasoline models

Equipped with K15, K21, or K25 gasoline engine

Diesel models

Equipped with S4Q2 or S4S diesel engine

Powershift trucks

Trucks equipped with powershift transmission

Manual transmission trucks

Trucks equipped with manual transmission (2 types of clutch; dry and wet)

3. Symbols and Abbreviations

Symbol or abbreviation	Meanings
OP.	Option
R1/4	Taper pipe thread (external) 1/4 inch (formerly PT1/4)
Rc1/8	Taper pipe thread (internal) 1/8 inch (formerly PT1/8)
G1/4A	Straight pipe thread (external) 1/4 inch (formerly PF1/4-A)
Rp1/8	Straight pipe thread (internal) 1/8 inch (formerly PS1/8)

4. Units

- SI Units are used in this manual.
- The following table shows the conversion of SI unit and customary unit:

Item	SI unit	Metric unit	Yard-pound unit
Force	1 N	0.102 kgf	0.225 lbf
Pressure	1 MPa	10.1972 kgf/cm ²	145.038 psi
Torque	1 N·m	0.102 kgf·m	0.7376 lbf·ft
Length	1 mm	-	0.039 in.
	1 m	-	3.281 feet
Weight	1 kg	-	2.205 lb
Temperature	1 °C	-	°F = 1.8 x °C + 32
Volume	1 L	-	0.264 US.gal.

Engine coolant temperature - the number of dots on screen

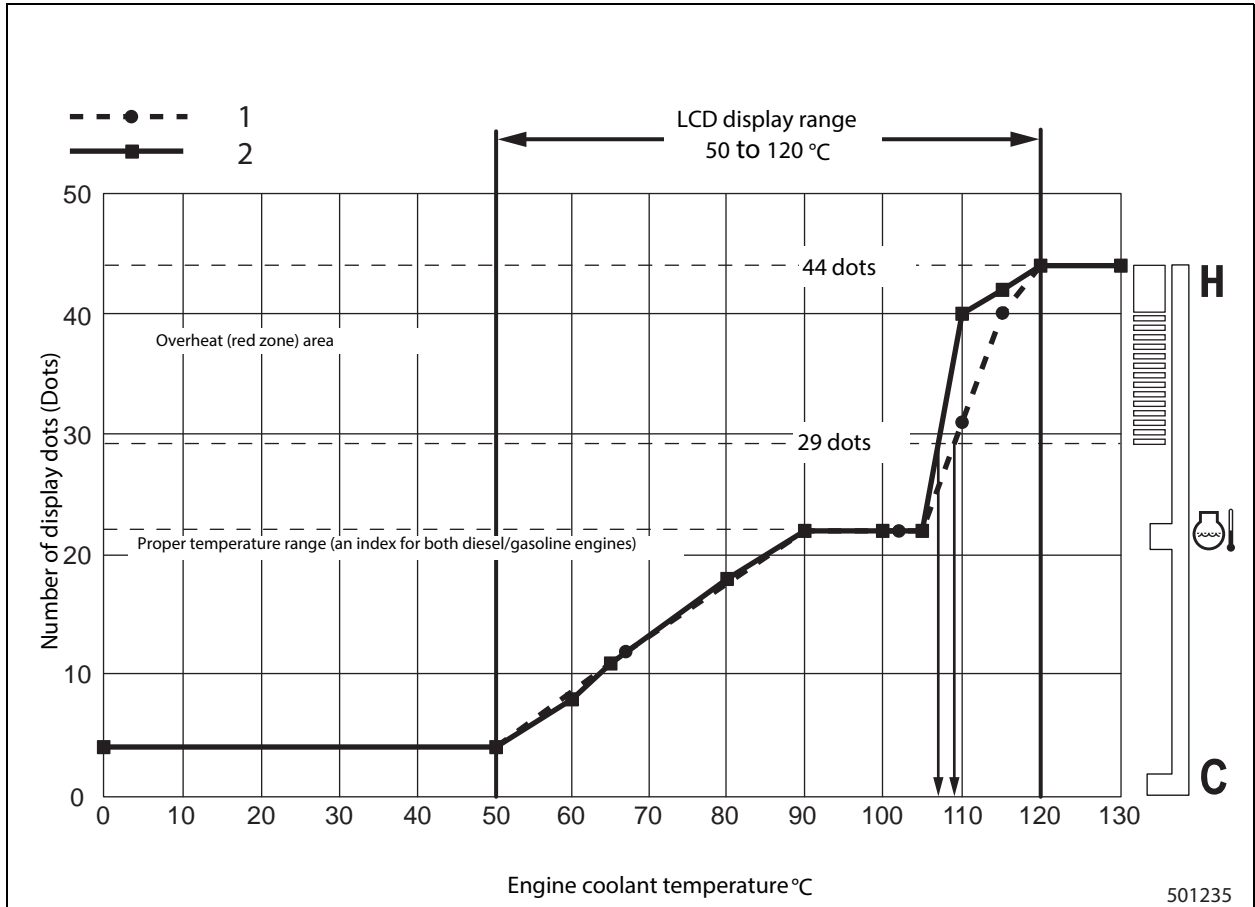

1. Diesel engine models
2. Gasoline engine models

Note: Red zone is 29 dots or more.
 Diesel models: about 109 °C (228 °F) or higher
 Gasoline models: about 107 °C (225 °F) or higher

Travel direction display

The truck traveling direction is displayed. If the direction lever is not in the N (NEUTRAL) position when starting the engine, the symbol "N" blinks and the engine will not start. If an operator leaves the seat while the engine is running and the direction lever is not in the N (NEUTRAL) position, the symbol "N" blinks and the transmission is electrically shifted to the NEUTRAL.

Note:

- Travel direction display is switched by the signal from the direction lever.
- Manual T/M truck shows N (NEUTRAL) only, and does not show forward and reverse.
 Also, blinking N (Driving interlock indication) is not shown.

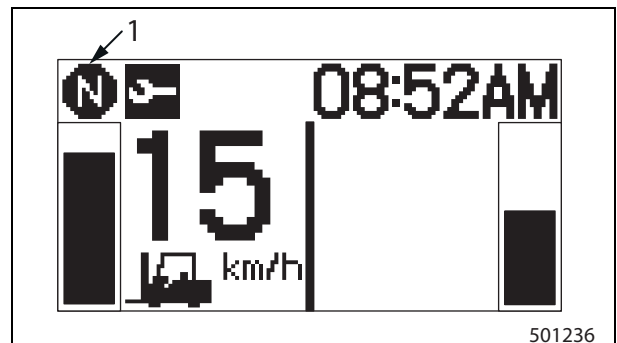

1. Truck direction indicator

6.2 Seat Belt Warning Light, Checking the Operation

- (1) Connect the service tool to the VCM-1M controller.
- (2) Turn the key switch to the ON position and start the engine.
- (3) Display the input monitor screen of the service tool.
- (4) Make sure that the seat switch status is turned OFF when the seat belt is not fastened or not buckled properly. Also check that the seat belt warning light in the meter panel glows.

Item	Normal Range	Value
Seat Switch	* - *	ON
Seat Switch timer	* - *	ON
Seatbelt Switch	* - *	OFF
Accel Switch	* - *	ON
Park brake Switch	* - *	ON
Direction lever F	* - *	OFF
Direction lever N	* - *	ON
Direction lever R	* - *	OFF
FNR lever	* - *	Neutral
Joystick (Lift lever 1) signal [%]	-100 - 100	0
Joystick (Lift lever 1) status	* - *	Normal
Joystick (Lift lever 2) signal [%]	-100 - 100	0
Joystick (Lift lever 2) status	* - *	Normal
Joystick (Tilt lever 1) signal [%]	-100 - 100	0
Joystick (Tilt lever 1) status	* - *	Normal
Joystick (Tilt lever 2) signal [%]	-100 - 100	0
Joystick (Tilt lever 2) status	* - *	Normal
Joystick (ATT1 lever 1) signal [%]	-100 - 100	0
Joystick (ATT1 lever 1) status	* - *	Normal
Joystick (ATT1 lever 2) signal [%]	-100 - 100	0
Joystick (ATT1 lever 2) status	* - *	Normal
Joystick (ATT2 lever 1) signal [%]	-100 - 100	0
Joystick (ATT2 lever 1) status	* - *	Normal
Joystick (ATT2 lever 2) signal [%]	-100 - 100	0
Joystick (ATT2 lever 2) status	* - *	Normal

501411

If Seat belt switch does not indicate ON

Check the seat belt switch operation and wiring connections by referring to 4-38 "Harness Codes", 4-40 "VCM-1M Controller", and 4-44 "Seat Switch".

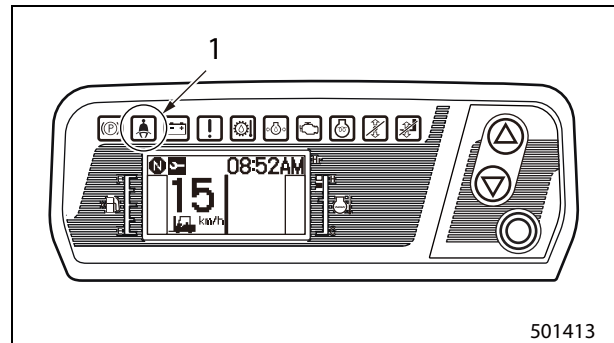

1. Lighting

- (5) Make sure that the seat belt switch turns ON and the seat belt warning light in the meter panel goes out when the seat belt is properly fastened.

Item	Normal Range	Value
Seat Switch	* - *	ON
Seat Switch timer	* - *	ON
Seatbelt Switch	* - *	ON
Accel Switch	* - *	ON
Park brake Switch	* - *	ON
Direction lever F	* - *	OFF
Direction lever N	* - *	ON
Direction lever R	* - *	OFF
FNR lever	* - *	Neutral
Joystick (Lift lever 1) signal [%]	-100 - 100	0
Joystick (Lift lever 1) status	* - *	Normal
Joystick (Lift lever 2) signal [%]	-100 - 100	0
Joystick (Lift lever 2) status	* - *	Normal
Joystick (Tilt lever 1) signal [%]	-100 - 100	0
Joystick (Tilt lever 1) status	* - *	Normal
Joystick (Tilt lever 2) signal [%]	-100 - 100	0
Joystick (Tilt lever 2) status	* - *	Normal
Joystick (ATT1 lever 1) signal [%]	-100 - 100	0
Joystick (ATT1 lever 1) status	* - *	Normal
Joystick (ATT1 lever 2) signal [%]	-100 - 100	0
Joystick (ATT1 lever 2) status	* - *	Normal
Joystick (ATT2 lever 1) signal [%]	-100 - 100	0
Joystick (ATT2 lever 1) status	* - *	Normal
Joystick (ATT2 lever 2) signal [%]	-100 - 100	0
Joystick (ATT2 lever 2) status	* - *	Normal

501416

Securing pressure plate assembly

Tighten the mounting bolts to the specified torque, and remove the bolts and washers (special tools to compress the pressure springs).

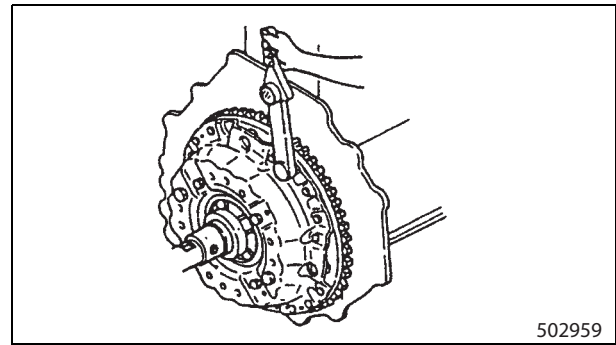

502959

Item	Tightening torque
Plate mounting bolt	17N·m (1.7 kgf·m) [12.54 lbf·ft]

Adjusting release lever height

Press the clutch gauge (for adjusting release lever clearance) against the side of the clutch cover. Watching the clearance between the release lever and the gauge, adjust the lever height.

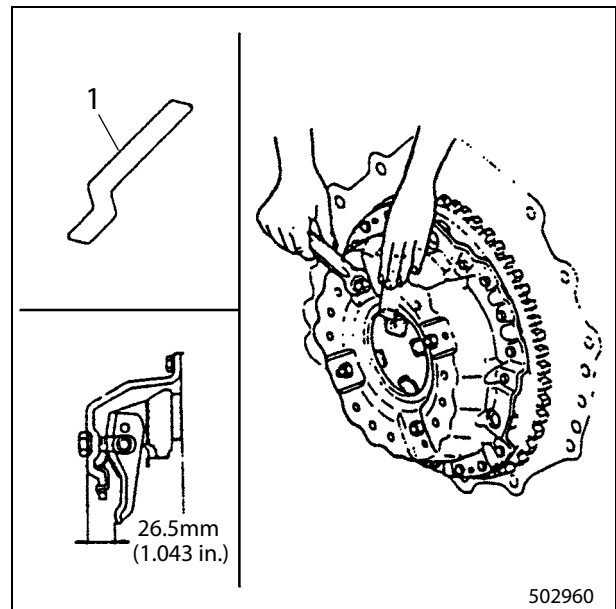

502960

1. Clutch gauge

Special tool	Part number
Clutch gauge	91268-02200

- (3) Remove transmission gasket.
- (4) Remove O-rings.

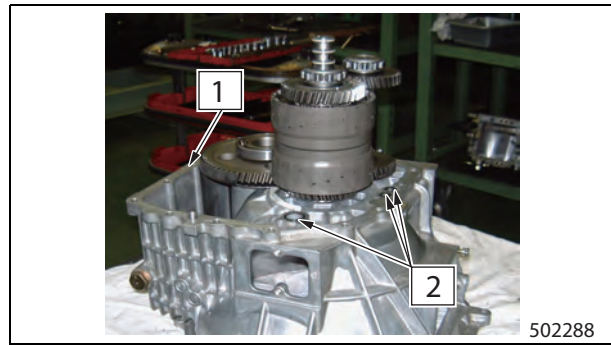

502288

1. Transmission gasket 2. O-ring

4.5 Input Shaft, Idler Shaft and Output Gear, Removing

Input shaft and idler shaft, Removing

- (1) Install guide bolts in two places at the bottom of torque converter housing, and raise the housing.

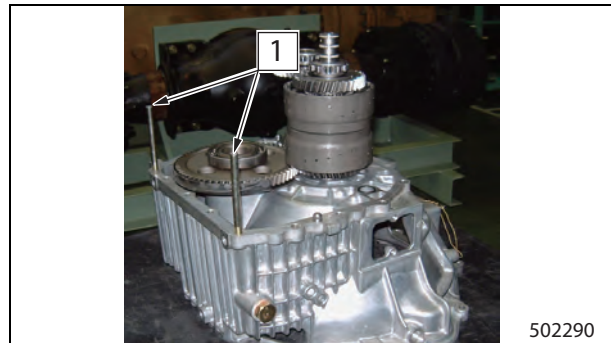

502290

1. Guide bolt

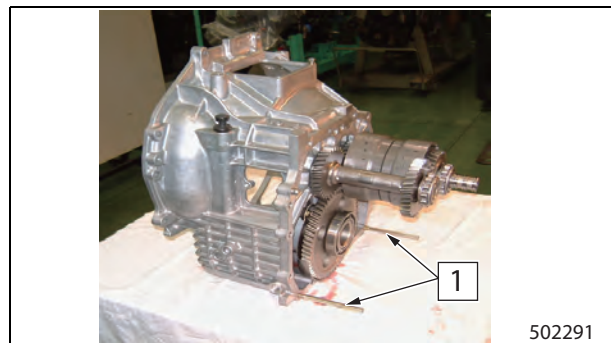

502291

1. Guide bolt

- (2) Wrap a wire around input shaft and idler shaft, and slightly raise them.

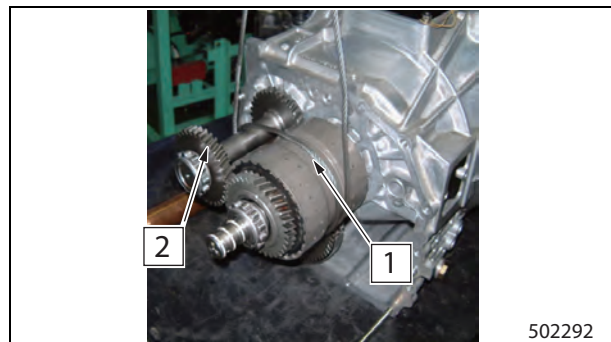

502292

1. Input shaft assembly 2. Idler shaft assembly

9. Troubleshooting

Condition		Possible cause	Action
Not enough output power	Engine	Engine lacks power	Adjust engine
		Poor engine performance	Adjust engine
	Torque converter	Oil level too low	Refill
		Air being sucked in	Tighten or replace O-ring
		Main regulator valve spool malfunction	Repair or replace
		Settling of spring in main regulator valve	Replace spring
		Worn gears in oil pump, resulting in reduced capacity	Disassemble/inspect. If defective, replace
		Magnet strainer clogged	Replace
		Seal rings or O-rings worn	Inspect. If defective, replace
		Seizure of stator freewheel	Replace torque converter assembly
		Impeller damaged or rubbing	Replace torque converter assembly
		Transmission	Air being sucked on suction side
	Outlet pressure too low to suppress internal bubble formation		Adjust pressure
	Water mixed in oil		Change oil
	Oil level too low		Refill
	Maladjusted pedal linkage (brake shift and forward/reverse)		Adjustment
	Main oil pressure too low, resulting in slipping clutches		Adjustment
	Seal rings or O-rings worn		Inspect. If defective, replace
	Clutch piston damaged		Replace
	Friction plate seized or dragging		Replace
Wheels	High-resistance loads on wheels	Check and/or adjust brake system	

12.2 Manual Adjustment Procedure

Using a screwdriver through a hole on the back of the backing plate, adjust the drum-to-lining clearance to specification by rotating the adjusting screw wheel. Adjust to 0.25 to 0.5 mm (0.0098 to 0.020 in.) (1 ton class), 0.1 to 0.35 mm (0.004 to 0.0138 in.) (2, 3 ton classes) at the highest point of the shoe width.

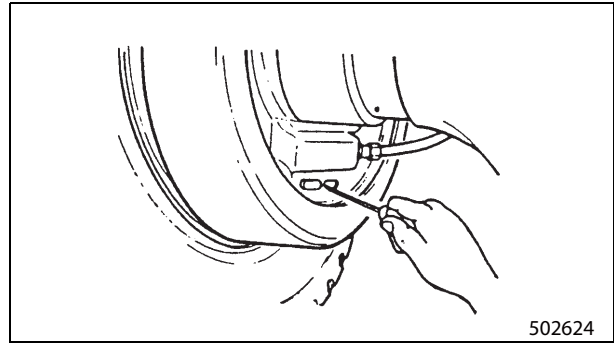

502624

Item	Specified value	
	1 ton class	2, 3 ton classes
Change in shoe diameter by one tooth of wheel	0.03 mm (0.0012 in.)	0.026 mm (0.0010 in.)

26. Suction Strainer and Return Filter, Removing

26.1 Removal Sequence

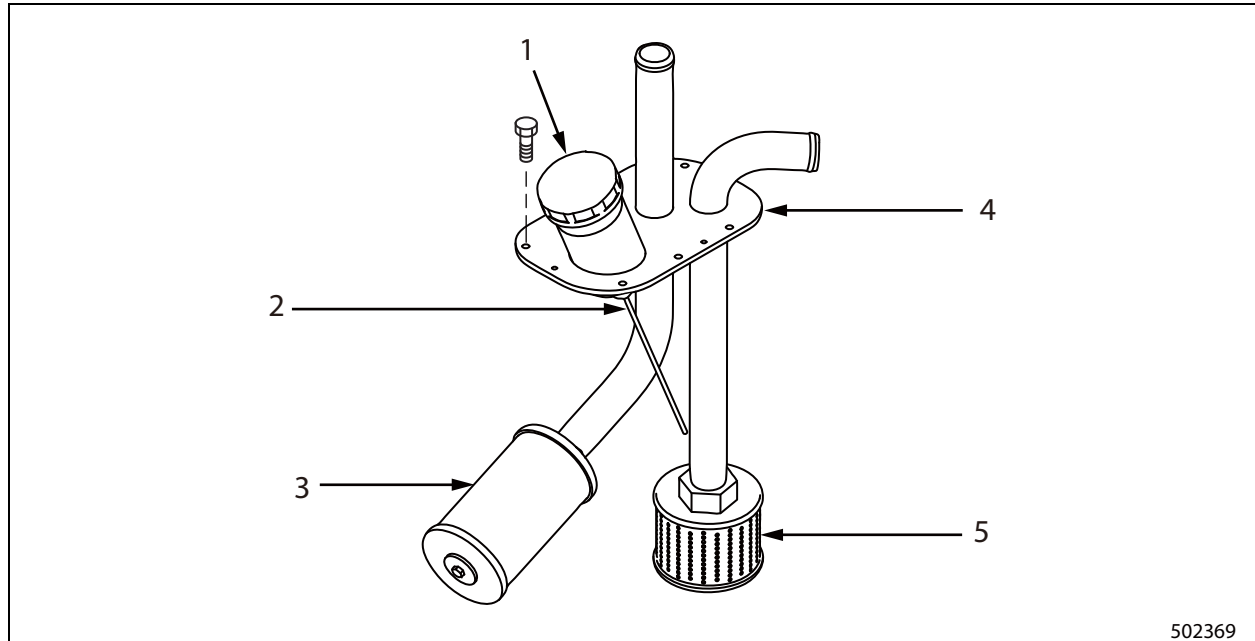

- | | |
|----------------|---------------------|
| 1. Cap | 3. Return filter |
| 2. Level gauge | 4. Tank cover |
| | 5. Suction strainer |

26.2 Suggestions for Removal

- (1) Remove the suction hose from the pump.
- (2) Remove the hose of the return line from the control valve.
- (3) Remove all the tank cover mounting bolts.
- (4) Lift the tank cover. Cover can be removed from the tank in assembled condition shown in the figure.
- (5) Remove the suction strainer and return filter.

27. Suction Strainer and Return Filter, Inspecting

- (1) Wash the suction strainer.
- (2) The return filter requires periodic replacements. Replace the filter every oil change. Also replace the filter one month after the purchase a new lift truck or one month after every overhaul.

28. Suction Strainer and Return Filter, Installing

To install, follow the removal sequence in reverse.

28.1 Suggestions for Installation

- (1) Tighten the strainer and filter to the specified torque.

Part name	Tightening torque
Return filter	49 ± 9.8 N·m (5.0 ± 0.99 kgf·m) [36.14 ± 7.22 lbf·ft]
Suction filter	49 ± 9.8 N·m (5.0 ± 0.99 kgf·m) [36.14 ± 7.22 lbf·ft]
Tank cover mounting bolt	5.1 to 6.5 N·m (0.52 to 0.66 kgf·m) [3.762 to 4.794 lbf·ft]

- (2) Securely install the pump suction hose to prevent air from being sucked.

2.6 Mast and Lift Bracket, Disassembly Sequence

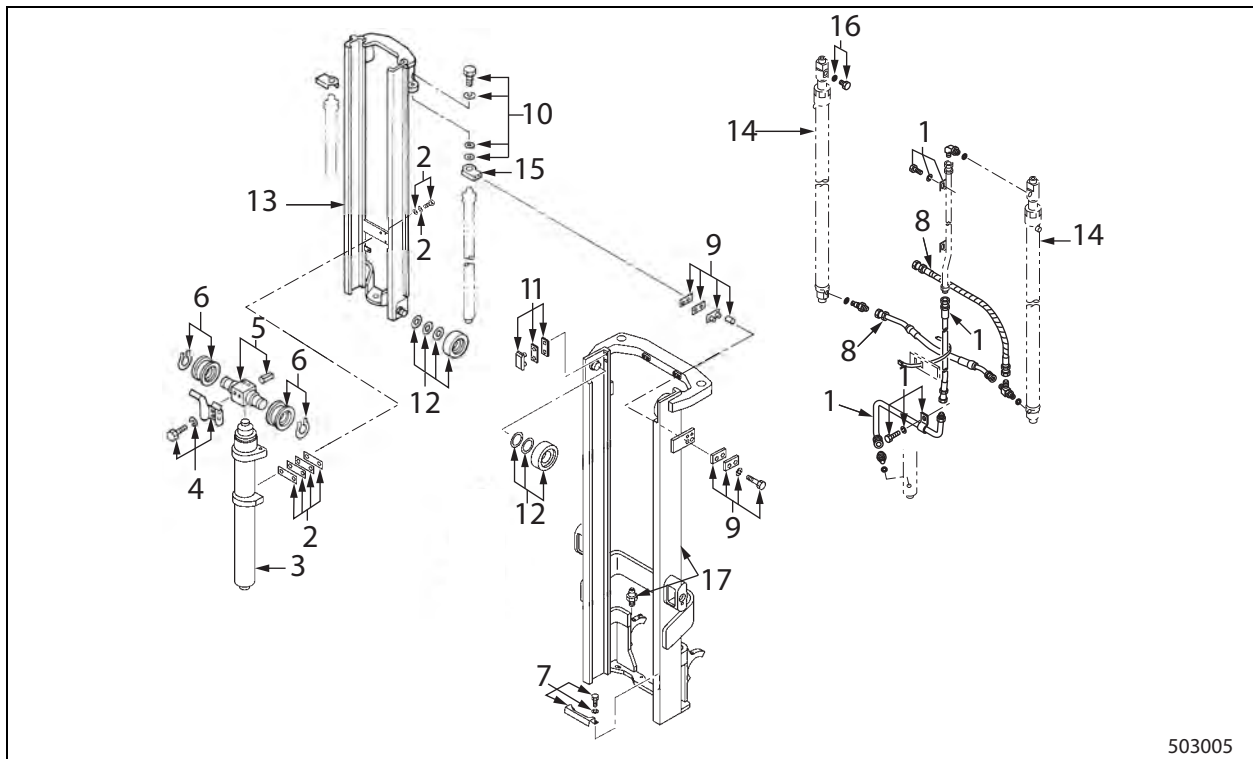

503005

- | | |
|---|-------------------------------|
| 1. Lift hose (high pressure), Clamp | 10. Set bolt, Washer, Shim |
| 2. Shims, Bolts, Washers | 11. Mast strip, Shims |
| 3. First lift cylinder | 12. Mast main roller |
| 4. Chain guard | 13. Inner mast |
| 5. Chain wheel support, Pin | 14. Second lift cylinder |
| 6. Chain wheels, Snap rings | 15. Cylinder bracket |
| 7. Hose guard, Bolt, Washer | 16. O-ring, Plug |
| 8. High-pressure hose | 17. Outer mast, Grease nipple |
| 9. Seats, Shims, Cushions, Collars, Clamps, Clamp bolts | |

Note: The lift bracket disassembly procedure is the same as that of the simplex mast.

2.7 Preparation for Disassembly of Mast and Lift Bracket

Lay the mast assembly horizontally on wood blocks with the lift bracket side facing up.

Place a wood block as a wedge to prevent the inner mast from sliding.

Before disassembling the mast and fork assembly, measure and record all clearances between each lift bracket and roller and between each mast and roller. Recorded measurements will be helpful when replacing rollers or selecting shims to adjust clearances.

3. Periodic Replacement Parts

The important parts (marked with *) and elements for safe operation listed below must be replaced at every designated replacement period.

No.	Periodic Replacement Parts	Replacement period			Remark
		Year span (year)	Month span (month)	Service hours span (hour)	
1	* Brake master cylinder hoses and rubber parts	1		2000	
2	* Rubber parts for brake wheel cylinder	1		2000	
3	* Clutch master cylinder hoses and rubber parts (Manual transmission truck only)	1		2000	
4	* Clutch release cylinder hoses and rubber parts (Manual transmission truck only)	1		2000	
5	* LPG repair kit (LPG model only)	1		2000 to 4000	
6	* Hydraulic hose (high-pressure hose)	1 to 2		2000	
7	* Power steering cylinder rubber parts	2		4000	
8	* Power steering cylinder hose	2		4000	
9	* Lift chain	2		4000	
10	* Fuel hoses	2		4000	
11	Engine oil filter		3	500	Also 1 month after delivery
12	Fuel filter (diesel)		6	1000	Also 1 month after delivery
13	Fuel filter (G and dual G/L non electronic control engine)		6	1000	Also 1 month after delivery
14	Hydraulic tank return oil filter		6	1000	Also 1 month after delivery
15	Air cleaner element		6	1000	Cleaning should be conducted every month (every 2 weeks in a dusty environment)
16	LPG fuel filter	1		2000	
17	Spark plug		18	3000	Check every month

Note: "*" indicates safety critical parts.

4.7 Horn

Check that the horn sounds when applying the specified voltage to both terminals of the horn, T1 and T2.

Replace the horn with a new one if it does not sound or its sound is abnormal.

Operating voltage: 10 to 14.5 V

Note: Refer to the illustration for the horn installed position.

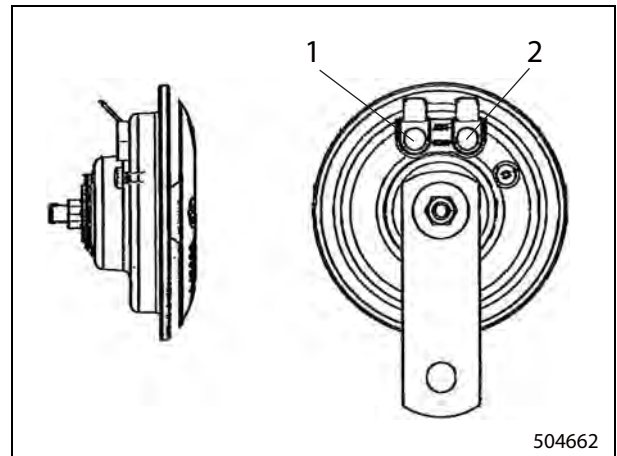

1. T-1

2. T-2

VCM controller signal allocation (MC model)

CN1			CN2		
Pin No.	Circuit No.	Harness destination	Pin No.	Circuit No.	Harness destination
1	-		1	610	Seat
2	-		2	609	Seat
3	676	Lift SW	3	-	
4	677	Tilt SW	4	623	Tilt horizontal SW
5	-		5	-	
6	723	Speed select SW	6	-	
7	722	Power select SW	7	642	LPG/Gas Selector SW
8	707	Junction	8	345	Coolant level sensor
9	708	Junction	9	346	Air dust sensor
10	704	Tilt angle sensor	10	343	Oil temperature SW
11	705	Tilt angle sensor	11	374	LPG warning
12	706	Tilt angle sensor	12	-	
13	-		13	-	
14	663	Hydraulic sensor	14	-	
15	662	Hydraulic sensor	15	670	T/M control solenoid
16	664	Hydraulic sensor	16	671	T/M control solenoid
17	-		17	672	T/M control solenoid
18	-		18	-	
19	-		19	679	Tilt lock solenoid
20	-		20	678	Tilt lock solenoid
21	-		21	-	
22	-		22	-	
23	-		23	-	
24	630	Unload solenoid	24	-	
25	628	Lift lock solenoid	25	603	Relay box
26	631	Unload solenoid	26	127	ECM
27	625	Circuit No. 371 (Warning buzzer to Relay box)	27	702	Speed sensor
28	-		28	703	Speed sensor
29	LPG: 156 Diesel: 716	ECM (156) Resistor (716)	29	-	
30	LPG: 155 Diesel: 715	ECM (155) Resistor (715)	30	-	
31	600	Fuse box	31	-	
32	975	Circuit No. 910 (ECM to GND)	32	-	
33	601	Circuit No. 600 (Fuse box)	33	-	
34	976	Circuit No. 975 (ECM to GND)	34	-	

11.6 E-31 (Throttle Control Warning)

Diagnostic code E-31

Electronic control throttle control warning signal.

The code definition for DTC E-31

Mechanical malfunctions occur to the actuator.

Examples: Sticking throttle plate. It can be stuck open or closed from carbon type buildup in the throttle bore and plate. The internal springs can fail and not allow the throttle plate to open or close.

Electronic malfunction

This affects throttle sensor calibrated position during key ON or startup. When the ECM sees the actual position and it is outside the set parameters it will open the relay. Code E31 will set after. The MIL lamp will illuminate.

The system detects a short to ground or open during key ON or running. The Fail Safe System will deactivate the throttle relay and the throttle body will become non-operational. Engine will only idle. Fuel injection is inhibited.

This is the Fail Safe function. System defaults to engine idle at 800 min^{-1} .

The most frequent failure we see is open circuits at the chassis harness connector to the ETC. Wires will fatigue and break. We then perform Pin Point Testing.

Check wires one at a time by removing the wire and pin from the connector.

Installing oil seal

- (1) Install oil seal using installer (special tool).
- (2) Apply grease on the lip portion.

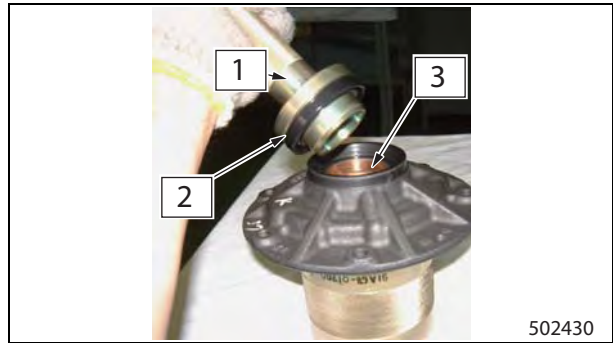

1. Special tool (Installer) 3. Bushing
2. Oil seal

502430

Part name	Part number	Qty
Oil seal	91A24-07900	1

Assembling Oil pump assembly

- (1) With the internal and drive gears mounting side facing up, place the oil pump body on the stand (special tool).
- (2) Install internal and drive gears to the pump body and apply oil to the gears.
- (3) Rotate the drive gear by hand and make sure the drive gear rotates freely.

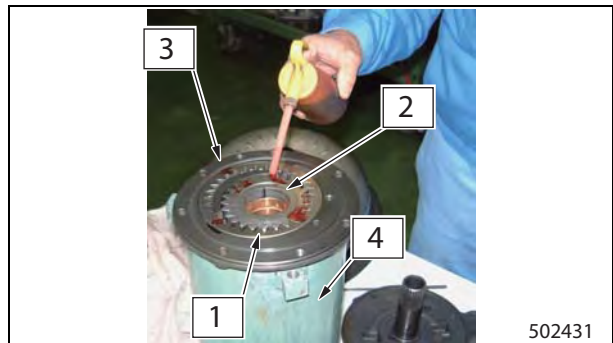

1. Internal gear 3. Pump body
2. Drive gear 4. Special tool (Installer)

502431

- (4) Install O-ring.
- (5) Install guide bolt and install stator shaft.

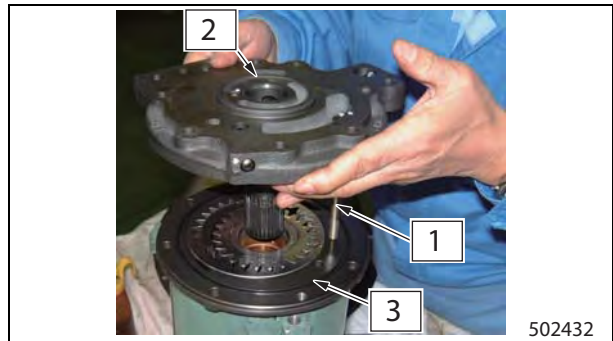

1. Guide bolt 3. O-ring
2. Stator shaft

502432

Part name	Part number	Qty
O-ring	91A24-08300	1

Adjusting reduction pinion preload

- After installing the tapered roller bearing, measure gap between the reduction pinion and tapered roller bearing to determine the required total shim thickness. The standard value of total shim thickness is 1.25 mm (0.049 in.).
- Five different thicknesses of shims are available. Use appropriate shims and tighten the plate.

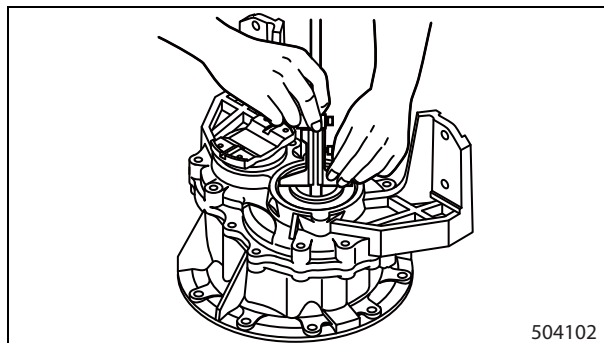

Shim thickness	Part number
0.05 mm (0.0020 in.)	97E27-01400
0.1 mm (0.0039 in.)	97E27-00800
0.2 mm (0.0079 in.)	97E27-00900
0.5 mm (0.020 in.)	97E27-01100
1.0 mm (0.0394 in.)	97E27-01200

- Hook a spring scale onto the bolt hole of the input flange, and pull it in the tangential direction to check the preload for the tapered roller bearing (the force when the flange starts rotating). Adjust the preload by increasing or decreasing the shims.

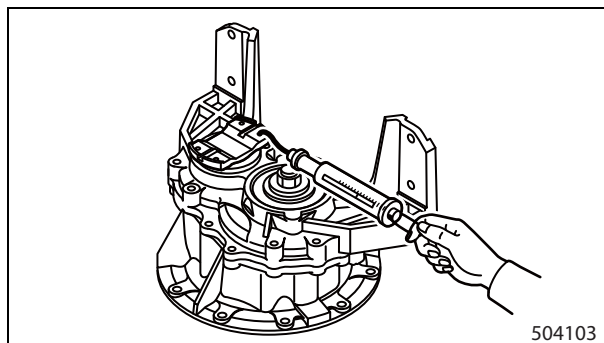

Tangential force (spring scale reading)
34.32 to 49.03 N (3.5 to 5.0 kgf) [7.7 to 11.0 lbf]

12. Troubleshooting

Condition	Possible Causes		Action
Stiff steering wheel operation	Defect in flow priority valve	No steering flow - Foreign materials clogged in spool pit - Fatigued or damaged spring in the spool	Disassemble and clean Replace spring
		Malfunction of relief valve - Low relief pressure - Damaged valve seating surface - Fatigued or damaged spring	Adjust relief pressure Replace valve assembly Replace springs and adjust relief pressure
		Oil leak from relief valve	
		- Damaged O-rings on the valve body circumference	Replace O-rings
		Defect in steering valve	Clogging in gerotor
	Malfunction by spool seizure due to foreign material		Replace
	Damaged bearing		Replace
	Excessive tightening of end cap mounting bolt		Assemble
	Defect in steering cylinder	Bent piston rod	Repair or replace
		Faulty piston seal	Replace
	Misalignment	Faulty installation of steering valve to tilt column	Readjust
	Other defects	Flattened pipe	Replace
Unstable steering operation	Defect in steering valve	Seizure of spool or sleeve	Replace
		Breakage of centering spring	Replace
	Other defects	Trapped air	Bleed
		Flattened pipe	Replace
		Faulty piston seal of steering cylinder	Replace

36. Removing MC Control Valve

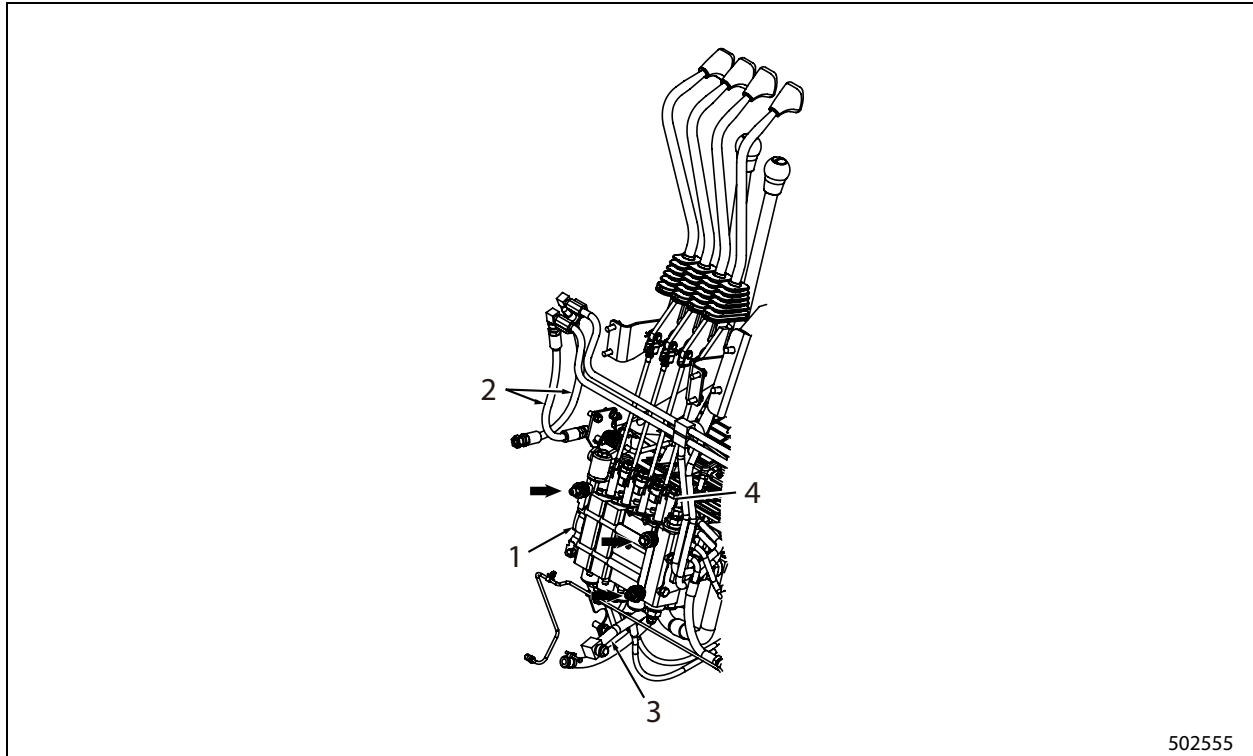

- | | |
|---------------------|---------------|
| 1. MC control valve | 3. Lift hose |
| 2. Tilt hoses | 4. Clevis pin |

36.1 Suggestions for Removal

- (1) Remove the floor plate.
- (2) Remove the clevis pin of the control lever rod and separate the rod from the control valve spool.
- (3) Disconnect each piping from the valve.
 - Pump delivery hose
 - Tilt pipe
 - Lift pipe
 - Return hose
 - Supply pipe to steering valve
 - Return hose from the steering valve
- (4) Separate the solenoid valve and harness of the micro-switch from the connector.
- (5) Remove valve mounting bolts and nuts (arrows in the illustration above) and remove the valve.

37. Installing MC Control Valve

To install, follow the reverse of removal sequence.

37.1 Suggestions for Installation

Check the hydraulic oil level. Replenish it to the specified level if the level is low.

1.26 Troubleshooting

Condition	Possible cause	Action
Lift bracket and inner mast do not move smoothly	Clearance between lift rollers and side rollers is incorrect	Adjust forward/backward and right/left clearances
	Defective roller rotation	Lubricate side rollers and replace other rollers
	Incorrect clearance on mast strip	Adjust shim thickness
Lift bracket or inner mast is tilted	Excessive clearance on side roller	Increase shim stack thickness
	Uneven tension between chains on right and left side	Adjust chain tension
	Shim adjustments are unequal between left and right lift cylinders (at the maximum height)	Adjust shim stack thickness
Mast makes noise	Defective roller rotation	Adjust or replace rollers after inspection
Drift (natural descent) of lift cylinders	Lift cylinder packing is damaged	Replace
	Sliding (inside) surface of lift cylinder tube is damaged	Replace
Whole mast shakes	Mast-support bushing or metal worn	Tighten or replace bushing metal
Mast is distorted	Off-center load or overload	Replace mast assembly
Fork tips are different in height	Distortion of finger bar	Repair or replace
	Distortion of forks	
	Uneven loading	

3.23 Adjusting Clearance Between Lift Bracket Roller and Inner Mast (All Mast Models)

Measuring back-to-front clearance on lift bracket main rollers

- (1) Raise the forks a little from the ground.
- (2) Insert a bar between the upper part of lift bracket and the inner mast, and push the inner mast to one side. Using feeler gauges, measure the clearance 1) between the main roller and inner mast on the opposite side.
- (3) If clearance 1) is out of specification, use oversize rollers. Remove lift bracket from mast and replace rollers with proper sized rollers. For roller replacement procedure, refer to 12-81 "Selecting roller of correct outer diameter".

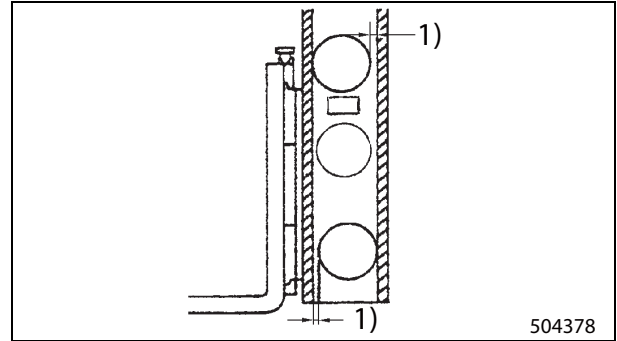

1) Clearance between main roller rolling face and inner mast

Ref.	Item	Standard
1)	Clearance between main roller rolling face and inner mast	1.0 mm (0.039 in.) or less

Measuring right-to-left clearance on lift bracket main rollers and side rollers

- (1) Raise the mast to the top.
- (2) Set a dial indicator on the inner mast with its contact point rested on the side of the lift bracket.
- (3) Go to the opposite side of the mast, and push the lift bracket to one side with a bar. Set the indicator to zero.
- (4) Insert a bar between the inner mast and lift bracket on the indicator side, and push the lift bracket to the opposite side.

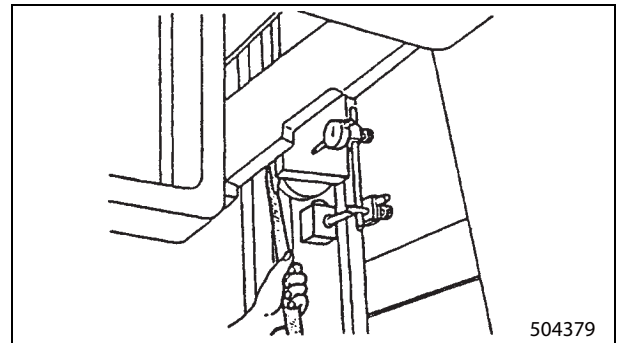

- (5) Read the indicator. This reading is the clearance 1) between middle roller and thrust plate. If clearance 1) is out of specification, it is necessary to add shims to the seat of the roller to adjust to correct clearance.

Note: Upper rollers are free from checking and adjusting.

For adjustment, refer to 12-82 "Adjusting clearance 2) between middle roller side face and thrust plate".

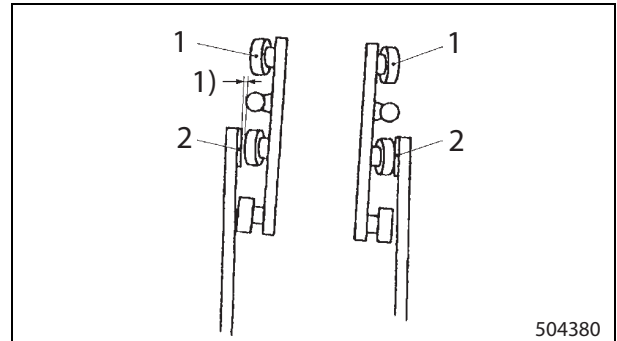

1. Upper roller
2. Thrust plate

1) Clearance between middle roller side face and inner mast thrust plate

Ref.	Item	Standard
1)	Clearance between middle roller side face and inner mast thrust plate	0.1 to 0.5 mm (0.004 to 0.020 in.)

3. Disassembling and inspecting damper, gear case, timing gear and camshaft

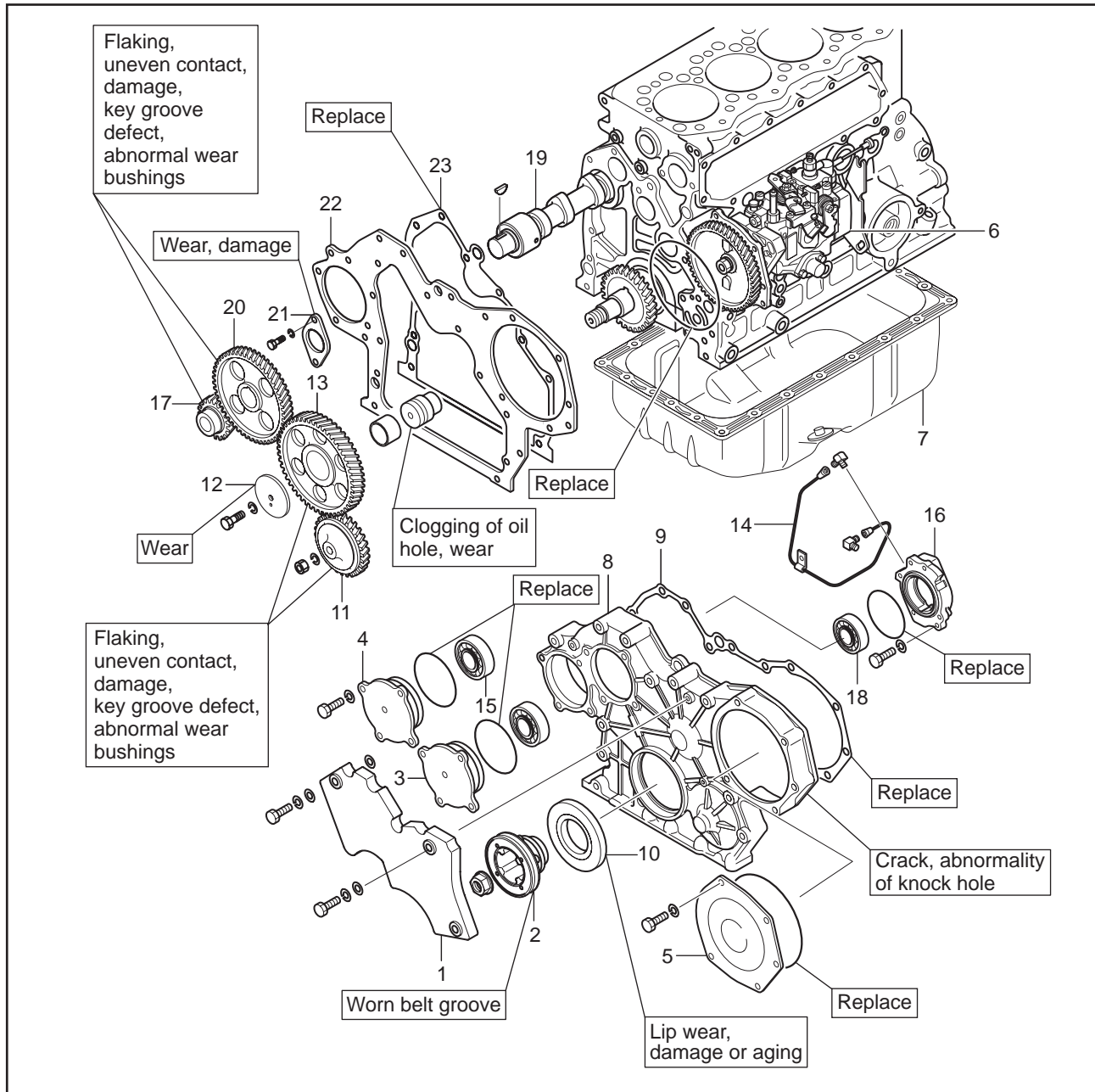

Disassembling and inspecting damper, gear case, timing gear and camshaft

Disassembling sequence

- | | | |
|-----------------------|---------------------------|---------------------------|
| 1 Insulator cover | 9 Gasket | 17 PTO drive gear |
| 2 Crankshaft pulley | 10 Oil seal | 18 PTO drive gear bearing |
| 3 Bearing case | 11 Oil pump gear | 19 Camshaft |
| 4 Bearing case | 12 Thrust plate | 20 Camshaft gear |
| 5 cover | 13 Idler gear | 21 Thrust plate |
| 6 Fuel injection pump | 14 Oil pipe | 22 Front plate |
| 7 Oil pan | 15 PTO drive gear bearing | 23 Gasket |
| 8 Timing gear case | 16 PTO bearing case | |

3.2 Installing fuel injection pipe

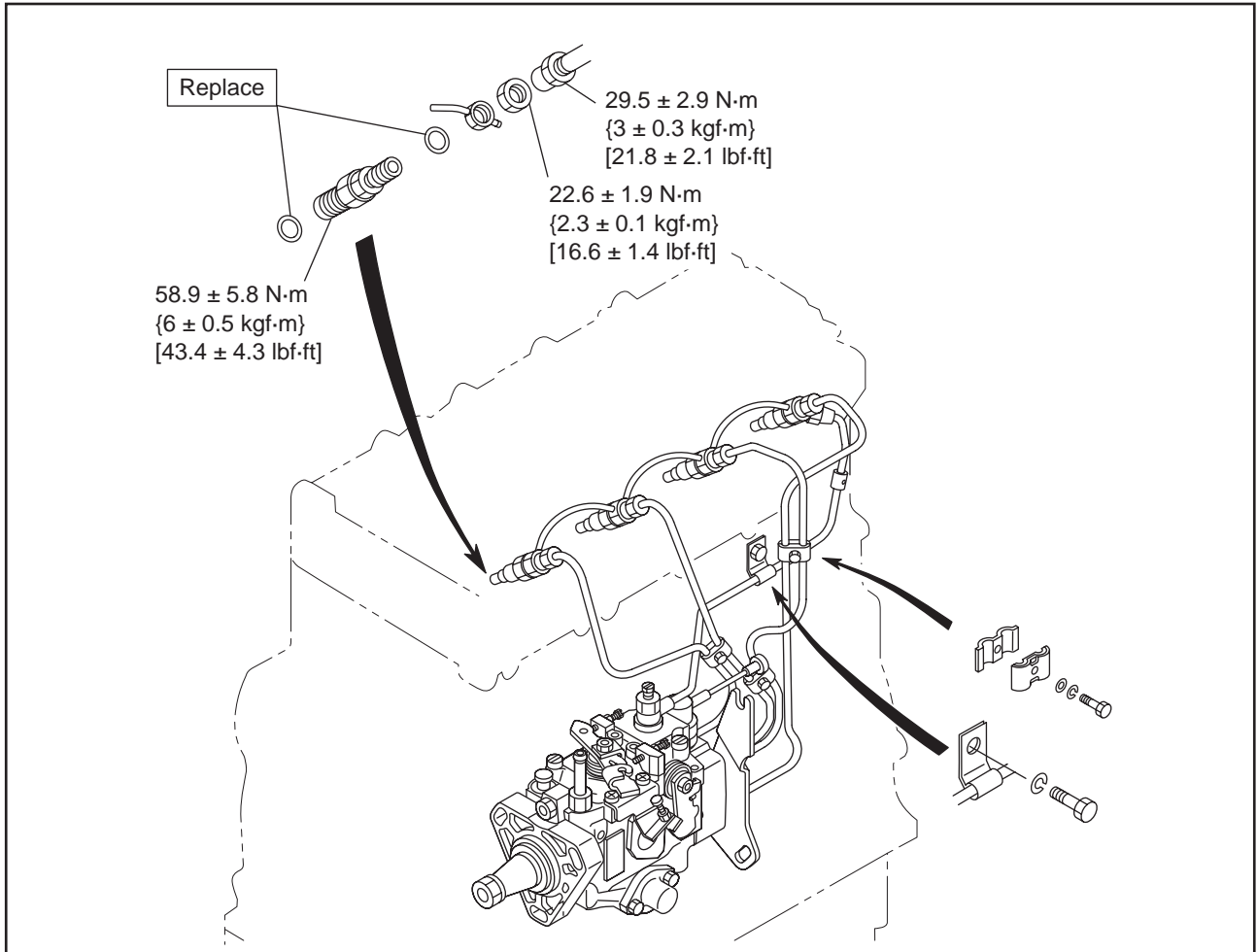

Installing fuel injection pipe



Service Manual

S4S Diesel Engine

194618-up

DP20N	P4000
DP25N	P5000
DP30N	P6000
DP35N	P7000

For use with DP20N, DP25N, DP30N, DP35N,
P4000, P5000, P6000, P7000 Chassis Service Manual.

99729-88100

3. Inspecting and repairing timing gear and camshaft

3.1 Measuring timing gear backlash

Measure the backlash of the timing gears by using one of the following two methods; measure the gear play with the dial gauge plunger applied to a tooth flank on the pitch circle at a right angle to the tooth axis, or measure the clearance between gears by inserting a thickness gauge between the gears at the tooth-to-tooth contacting area. Replace the faulty gear pair if the limit is exceeded.

Item	Standard	Limit
Timing gear backlash	0.05 to 0.15 mm [0.0020 to 0.0059 in.]	0.25 mm [0.0098 in.]

Note: With the injection pump gear attached to the pump, install the injection pump gear to the front plate.

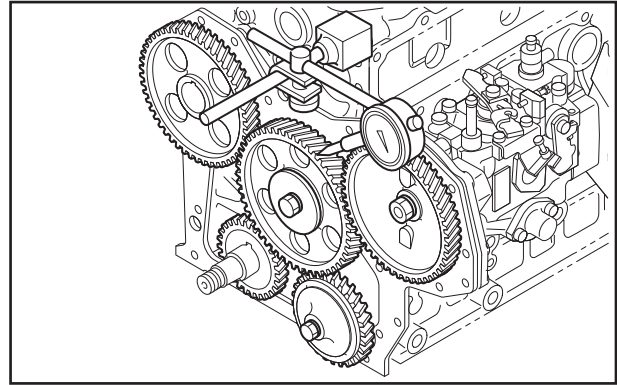

Measuring timing gear backlash

3.2 Measuring idler gear and camshaft gear end play

Using a thickness gauge or dial gauge, measure the end play of idler gear and camshaft gear. If the measured value exceeds the limit, replace the thrust plate with a new one.

Item	Standard	Limit
End play	Idler gear 0.05 to 0.20 mm [0.0020 to 0.0079 in.]	0.35 mm [0.0138 in.]
	Camshaft 0.10 to 0.25 mm [0.0039 to 0.0098 in.]	0.30 mm [0.0118 in.]

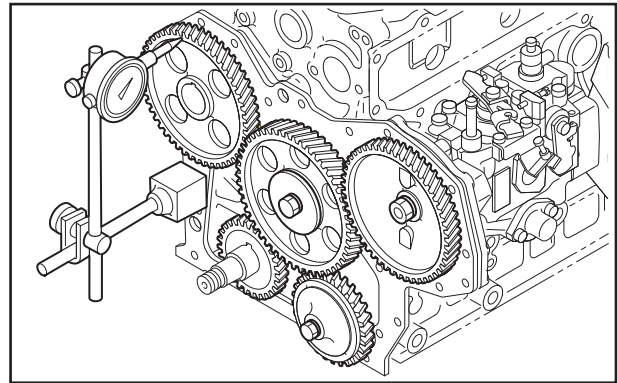

Measuring idler gear and camshaft gear end play

3.3 Measuring cam lift

Measure the minor and major axis of cam to determine cam lobe lift. If the lift is less than the limit, replace the camshaft with a new one.

Item	Nominal	Standard	Limit
Cam lift	Inlet 6.684 mm [0.2631 in.]	6.384 to 6.784 mm [0.2513 to 0.2671 in.]	6.184 mm [0.2435 in.]
	Exhaust 6.720 mm [0.265 in.]	6.420 to 6.820 mm [0.2528 to 0.2685 in.]	6.220 mm [0.2449 in.]

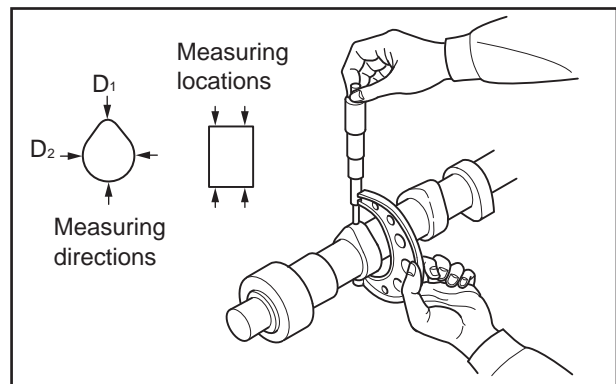

Measuring cam lift

CLICK HERE TO **DOWNLOAD** THE COMPLETE MANUAL

- Thank you very much for reading the preview of the manual.
- You can download the complete manual from: www.heydownloads.com by clicking the link below



- Please note: If there is no response to CLICKING the link, please download this PDF first and then click on it.

CLICK HERE TO **DOWNLOAD** THE COMPLETE MANUAL