

CASE

PROFESSIONAL PARTNER

SCHEMATIC SET CRAWLER EXCAVATOR

CX800 TIER 3

87539044 NA

Issued 06-2006

CLICK HERE TO **DOWNLOAD** THE COMPLETE MANUAL

- Thank you very much for reading the preview of the manual.
- You can download the complete manual from: www.heydownloads.com by clicking the link below



- Please note: If there is no response to CLICKING the link, please download this PDF first and then click on it.

CLICK HERE TO **DOWNLOAD** THE COMPLETE MANUAL



WARNING: Use insulated gloves or mittens when working with hot parts.



WARNING: Lower all attachments to the ground or use stands to safely support the attachments before you do any maintenance or service.



WARNING: Pin sized and smaller streams of hydraulic oil under pressure can penetrate the skin and result in serious infection. If hydraulic oil under pressure does penetrate the skin, seek medical treatment immediately. Maintain all hoses and tubes in good condition. Make sure all connections are tight. Make a replacement of any tube or hose that is damaged or thought to be damaged. **DO NOT** use your hand to check for leaks, use a piece of cardboard or wood.



WARNING: When removing hardened pins such as a pivot pin, or a hardened shaft, use a soft head (brass or bronze) hammer or use a driver made from brass or bronze and a steel head hammer.



WARNING: When using a hammer to remove and install pivot pins or separate parts using compressed air or using a grinder, wear eye protection that completely encloses the eyes (approved goggles or other approved eye protectors).



WARNING: Use suitable floor (service) jacks or chain hoist to raise wheels or tracks off the floor. Always block machine in place with suitable safety stands.



WARNING: When servicing or repairing the machine, keep the shop floor and operator's compartment and steps free of oil, water, grease, tools, etc. Use an oil absorbing material and/or shop cloths as required. Use safe practices at all times.



WARNING: Some components of this machine are very heavy. Use suitable lifting equipment or additional help as instructed in this Service Manual.



WARNING: Engine exhaust fumes can cause death. If it is necessary to start the engine in a closed place, remove the exhaust fumes from the area with an exhaust pipe extension. Open the doors and get outside air into the area.



WARNING: When the battery electrolyte is frozen, the battery can explode if (1), you try to charge the battery, or (2), you try to jump start and run the engine. To prevent the battery electrolyte from freezing, try to keep the battery at full charge. If you do not follow these instructions, you or others in the area can be injured.

Engine

Name	ISUZU, 6WG1X
Type: 4-cycle, water-cooled, overhead camshaft, common rail injection (electric control), with air-cooling type inter-cooler turbo with air-cooling.	
No. of cylinders - bore x stroke	6-dia. 147 mm x 154 mm (5.78 x 6.06 in)
Displacement	15.7 L (4.15 gal)
Compression ratio	16
Rated output	345 ± 7.0 kW / 1850 min ⁻¹
Maximum torque	2250 N•m (1659.51 lb-ft) / 1500 min ⁻¹
Engine dimensions (LxWxH)	1462x1017x1422 mm (57.55 x40.03x55.98 in)
Oil pan	All direction 35°, inclinable
Oil pan capacity	Maximum: 52 L (13.73 gal) Minimum: 37 L (9.77 gal) (excluding oil filter)
Direction of rotation	Right (viewed from fan side); compliant with
Starter, reduction type	24 V, 7 kW
Alternator, AC type	24 V, 50 A
Battery	2x 12V/24V,140 Ah/5 Hr

Cooling system

Fan drive system	hydraulic drive
Fan type	diameter 1016 mm (40 in), suction type-6blades, resin & steel
Radiator capacity	205.7kW
Fin type	wavy
Fin space	2.0 mm (0.07 in)
Oil cooler capacity	174.4 kW
Fin type	plate
Fin space	3.0 mm (0.11 in)
Inter-cooler capacity	63.3 kW
Fin type	triangular straight
Fin space	2.0 mm (0.07 in)
Fuel cooler capacity	3.58 kW
Fin type	wavy
Fin space	2.0 mm (0.07 in)
Coolant capacity	36 L (9.51 gal) (engine only)

Capacity of coolant and lubricants

Coolant	108 L (28.53 gal)
Fuel.....	900 L (237.75 gal)
Lubricant for engine	52 L (13.73 gal)
Lubricant for travel reduction gear (per side)	13.8 L (3.64 gal)
Lubricant for swing reduction gear (per side)	4.7 L (1.24 gal)
Hydraulic oil	720 L (190.20 gal)
Capacity of hydraulic oil tank	310 L (81.89 gal)

Hydraulic oil filter

Suction filter (inside tank)	150 mesh
Return filter (inside tank)	10 μ m
Nephron filter (inside housing).....	1 μ m
Pilot line filter (inside housing).....	10 μ m

Idler wheel

Dimensions

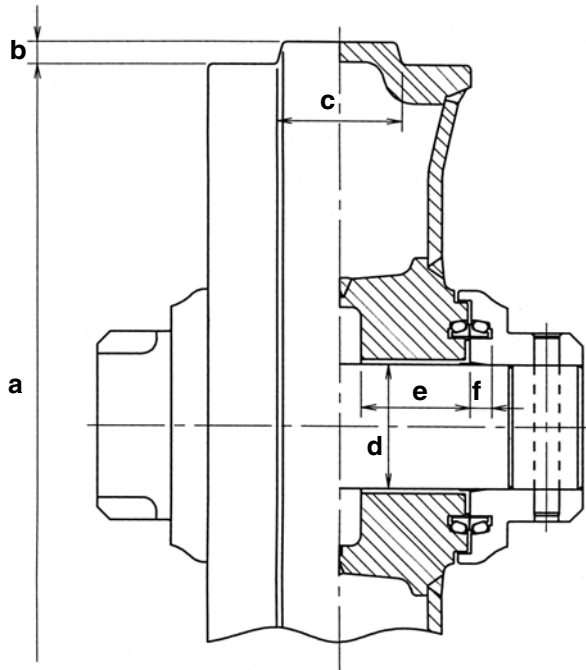

Mark		Dimension	
		mm	in
$\varnothing a$	Standard	830	32.67
	Limit	824	32.44
b	Standard	22.5	0.88
	Limit	25.5	1.00
c	Standard	127	4.99
	Limit	125	4.92
$\varnothing d$ (shaft)	Standard	125	4.92
	Limit	124	4.88
$\varnothing d$ (bushing)	Standard	125	4.92
	Limit	126	4.96
e (bushing)	Standard	110	4.33
	Limit	109.5	4.31
f	Standard	21.6	0.85
	Limit	-	-

700-6-10-00-10B

Gauge

Unit in mm

[Unit: mm]

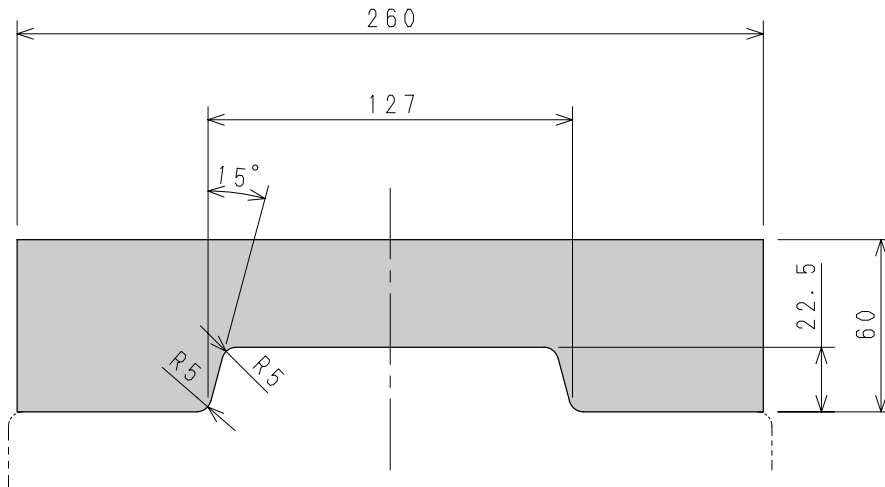

800-6-10-03-14B

SPECIAL TORQUE SETTINGS

No.	Component	Screw	Wrench (mm)	Torque setting
1 *	Travel motor and reduction gear assembly	M27	41	1307-1526 Nm (964 - 1125 lb-ft)
2 *	Sprocket	M27	41	1307-1526 Nm (964 - 1125 lb-ft)
3 *	Idler wheel			
4 *	Upper roller	M20	30	521-608 Nm (384-448 lb-ft)
5 *	Lower roller	M27	41	1307-1526 Nm (964-1125 lb-ft)
6 *	Chain guide	M30	46	1307-1526 Nm (964-1125 lb-ft)
7	Track pad	M27	30	1588-1869 Nm (1171-1378 lb-ft)
8	Counterweight	M42	65	2256-2550 Nm (1664-1880 lb-ft)
9*	Turntable (frame)	M30	46	1800-2100 Nm (1328-1549 lb-ft)
10*	Turntable (upperstructure)	M30	46	1800-2100 Nm (1328-1549 lb-ft)
11 *	Swing motor and reduction gear assembly	M24	36	900-1050 Nm (664-775 lb-ft)
12 *	Engine	M24	36	902-1049 Nm (665-774 lb-ft)
13 *	Engine bracket	M14	22	173-202 Nm (128-149 lb-ft)
14	Radiator	M20	30	520-608 Nm (384-448 lb-ft)
15 *	Hydraulic pump	M12	19	109-127 Nm (80-94 lb-ft)
16 *	Hydraulic reservoir	M20	30	471-258 Nm (347-419 lb-ft)
17 *	Fuel reservoir	M20	30	471-258 Nm (347-419 lb-ft)
18 *	Control valve	M20	30	343-392 Nm (253-289 lb-ft)
19 *	Hydraulic swivel	M12	19	109-127 Nm (80-94 lb-ft)
		M16	24	267-312 Nm (197-230 lb-ft)
20	Cab	M16	24	78-80 Nm (58-59 lb-ft)
21	Battery	M10	17	20-29 Nm (15-21 lb-ft)
22	Frame	M36	55	2550-2942 Nm (1880-2170 lb-ft)
23	Frame	M30	46	1781-2078 Nm (1314-1533 lb-ft)
24	Air cleaner			

NOTE: Use Loctite 262 or an equivalent on retaining screws of those components marked with an asterisk (*).

Feet to meters

ft.	0	1	2	3	4	5	6	7	8	9	ft.
	m	m	m	m	m	m	m	m	m	m	
----		0.305	0.610	0.914	1.219	1.524	1.829	2.134	2.438	2.743	----
10	3.048	3.353	3.658	3.962	4.267	4.572	4.877	5.182	5.486	5.791	10
20	6.096	6.401	6.706	7.010	7.315	7.620	7.925	8.230	8.534	8.839	20
30	9.144	9.449	9.754	10.058	10.363	10.668	10.973	11.278	11.582	11.887	30
40	12.192	12.497	12.802	13.106	13.411	13.716	14.021	14.326	14.630	14.935	40
50	15.240	15.545	15.850	16.154	16.459	16.764	17.069	17.374	17.678	17.983	50
60	18.288	18.593	18.898	19.202	19.507	19.812	20.117	20.422	20.726	21.031	60
70	21.336	21.641	21.946	22.250	22.555	22.860	23.165	23.470	23.774	24.079	70
80	24.384	24.689	24.994	25.298	25.603	25.908	26.213	26.518	26.822	27.127	80
90	27.432	27.737	28.042	28.346	28.651	28.956	29.261	29.566	29.870	30.175	90
100	30.480	30.785	31.090	31.394	31.699	32.004	32.309	32.614	32.918	33.223	100

Meters to feet

m	0	1	2	3	4	5	6	7	8	9	m
	ft.	ft.	ft.	ft.	ft.	ft.	ft.	ft.	ft.	ft.	
----		3.2808	6.5617	9.8425	13.1233	16.4042	19.6850	22.9658	26.2466	29.5275	----
10	32.8083	36.0891	39.3700	42.6508	45.9316	49.2125	52.4933	55.7741	59.0549	62.3358	10
20	65.6166	68.8974	72.1783	75.4591	78.7399	82.0208	85.3016	88.5824	91.8632	95.1441	20
30	98.4249	101.7057	104.9866	108.2674	111.5482	114.8291	118.1099	121.3907	124.6715	127.9524	30
40	131.2332	134.5140	137.7949	141.0757	144.3565	147.6374	150.9182	154.1990	157.4798	160.7607	40
50	164.0415	167.3223	170.6032	173.8840	177.1648	180.4457	183.7265	187.0073	190.2881	193.5690	50
60	196.8498	200.1306	203.4115	206.6923	209.9731	213.2540	216.5348	219.8156	223.0964	226.3773	60
70	229.6581	232.9389	236.2198	239.5006	242.7814	246.0623	249.3431	252.6239	255.9047	259.1856	70
80	262.4664	265.7472	269.0281	272.3089	275.5897	278.8706	282.1514	285.4322	288.7130	291.9939	80
90	295.2747	298.5555	301.8364	305.1172	308.3980	311.6789	314.9597	318.2405	321.5213	324.8022	90
100	328.0830	331.3638	334.6447	337.9255	341.2063	344.4872	347.7680	351.0488	354.3296	357.6105	100

Miles to kilometers

miles	0	1	2	3	4	5	6	7	8	9	miles
	km	km	km	km	km	km	km	km	km	km	
----		1.609	3.219	4.828	6.437	8.047	9.656	11.265	12.875	14.484	----
10	16.093	17.703	19.312	20.921	22.531	24.140	25.750	27.359	28.968	30.578	10
20	32.187	33.796	35.406	37.015	38.624	40.234	41.843	43.452	45.062	46.671	20
30	48.280	49.890	51.499	53.108	54.718	56.327	57.936	59.546	61.155	62.764	30
40	64.374	65.983	67.592	69.202	70.811	72.420	74.030	75.639	77.249	78.858	40
50	80.467	82.077	83.686	85.295	86.905	88.514	90.123	91.733	93.342	94.951	50
60	96.561	98.170	99.779	101.389	102.998	104.607	106.217	107.826	109.435	111.045	60
70	112.654	114.263	115.873	117.482	119.091	120.701	122.310	123.919	125.529	127.138	70
80	128.748	130.357	131.966	133.576	135.185	136.794	138.404	140.013	141.622	143.232	80
90	144.841	146.450	148.060	149.669	151.278	152.888	154.497	156.106	157.716	159.325	90
100	160.934	162.544	164.153	165.762	167.372	168.981	170.590	172.200	173.809	175.418	100

Section

4001

ELECTRICAL AND ELECTRONIC CIRCUIT AND TROUBLESHOOTING

B47. Boost pressure sensor

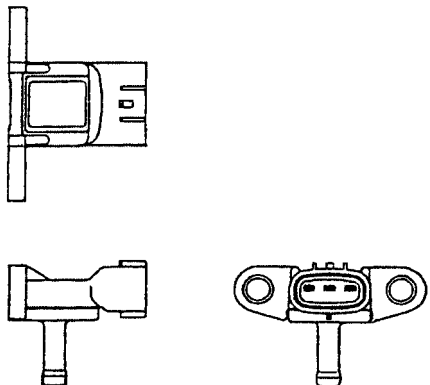

700.1.04.01.23AK

B48. Atmospheric pressure sensor

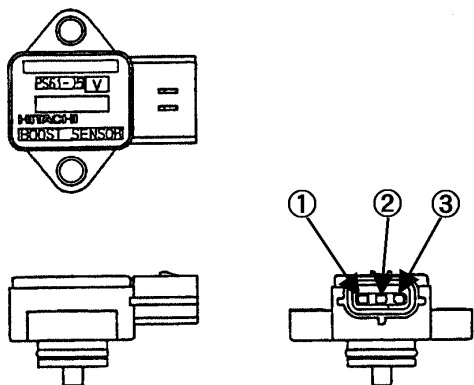

700.1.04.01.23AJ

- 1 Power, positive (+)
- 2 Power, negative (-)
- 3 Output

B49. Crankshaft position sensor

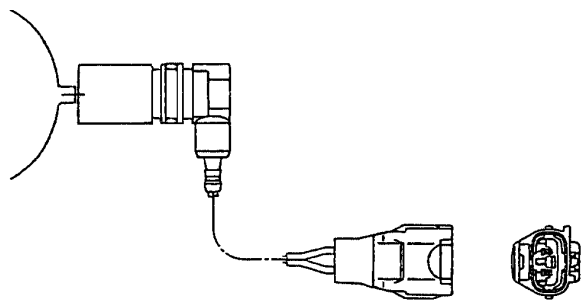

700.1.04.01.23AL

B50. Camshaft position sensor (or G sensor)

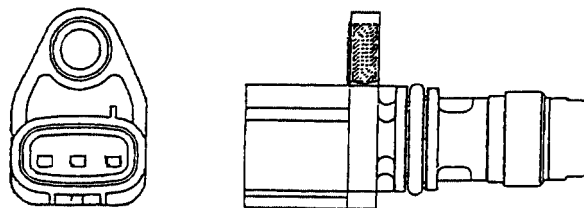

700.1.04.01.23AM

B51. Boost temperature sensor

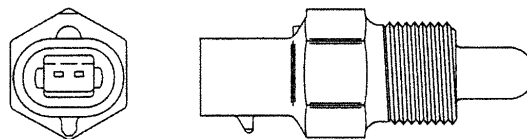

700.1.04.01.23AH

R5. Fuel level sensor

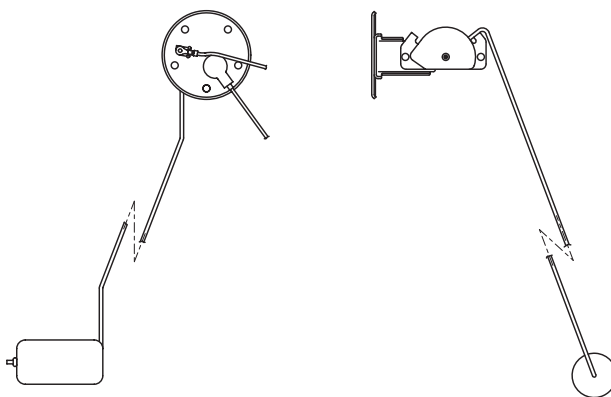

700.1.04.01.23AO

S62. Vacuum sensor

Operating negative pressure: $6.27 \pm 0.29\text{kPa}$.

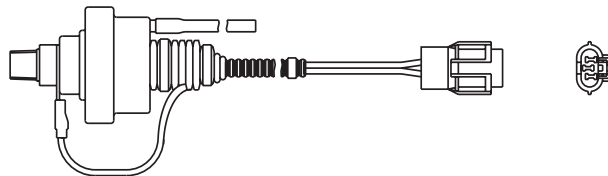

700.1.04.01.23AN

B) Load pre-fetch control

1) Purpose

Pump current is controlled as measures against black smoke.

2) Circuit configuration

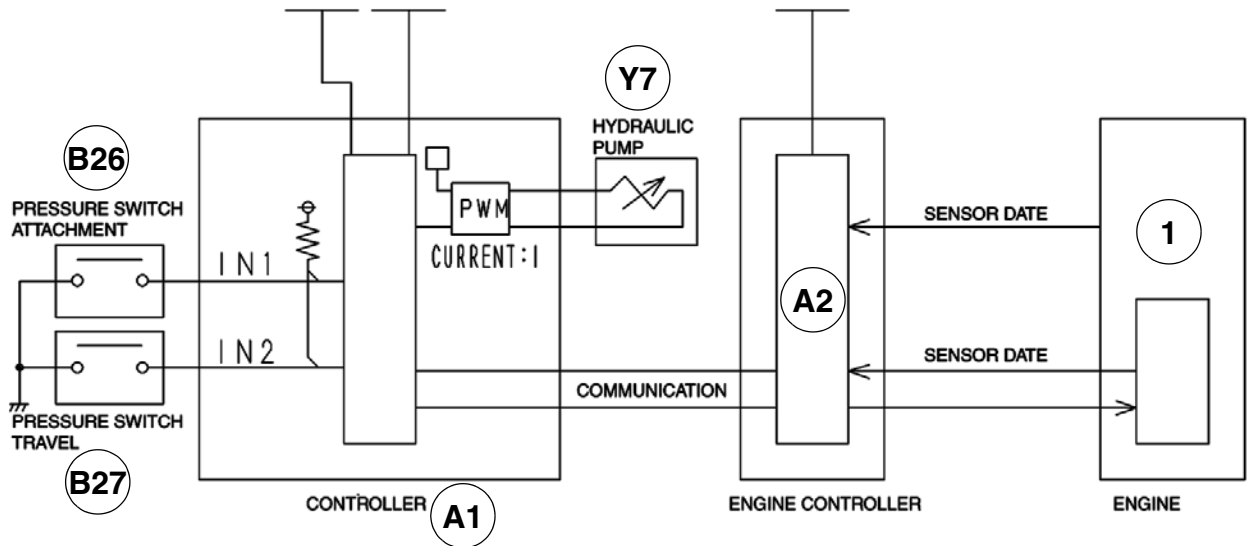

- 1 Engine
- A1 Computer/Controller
- A2 Engine controller

- B26 Upper pilot pressure switch (yellow band)
- B27 Travel pilot pressure switch
- Y7 Main pump proportional solenoid

700.1.04.01.23AU

3) Operation

1. When no operation is carried out (attachment and travel pressure switches OFF), the pump current is always 0 mA regardless of operation mode and engine speed.
2. When attachment or travel pressure switch is turned ON, the controller provides pump current so that it can get to the set current for the work mode being selected after 0.8 second.

* No control for decreasing transient load has been employed for machines above current model of CX330.

Control for decreasing transient load is illustrated below:

Since engine response (or returning property) has been improved (or no difference between target speed and actual speed), if an abrupt engagement of the lever from inching operation is carried out, and when difference between target speed and actual speed reaches within 150 min^{-1} , pump current of 0 mA is to be applied to ease the engine load.

This is for the purpose of taking measures against black smoke and of prevention from engine stop.

AUTO WARM UP

1) Circuit configuration

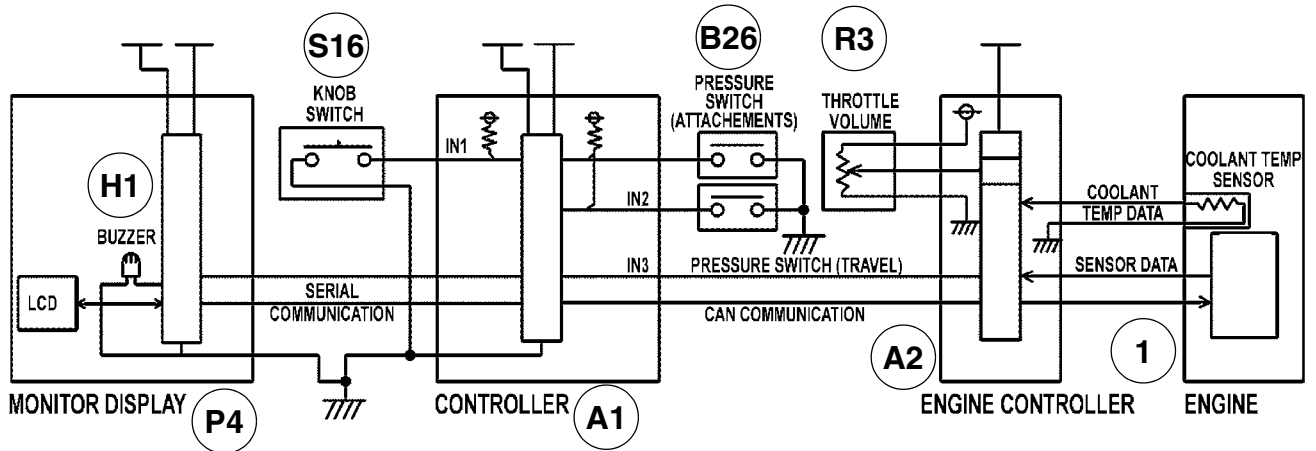

- 1 Engine
- A1 Computer/Controller
- A2 Engine controller
- B26 Upper pilot pressure switch (yellow band)

- H1 Audible warning device
- P4 Monitor display
- R3 Throttle volume
- S16 One touch idle

700.1.04.01.23BB

2) Operation

1. A coolant temperature sensor is installed inside the engine. The signal from this sensor goes out to the engine controller and is converted into a temperature value. The engine controller then transmits the coolant temperature data to the controller via CAN communication.
2. If the coolant temperature is below 50°C (122°F) after engine starts, the controller transmits the auto warm-up signal to the engine controller via CAN communication.
3. The engine controller executes the auto warm-up control upon receiving the signal transmission from the controller.
4. The controller terminates the auto warm-up control on the following conditions. The engine controller terminates the auto warm-up control once the command is cancelled.
 - *When one of the following switches turns on: attachment pressure switch, travel pressure switch, and knob switch (one-touch idle switch).
 - *When throttle volume is changed.
 - *When engine speed stays above 1800 min⁻¹ for 3 minutes.
5. Once auto warm-up control is cancelled, the controller does not initiate auto warm-up control again unless key switch is turned from OFF to ON.
6. While controller is executing the auto warm-up control, an "AUTO WARM UP" message is displayed on the monitor's LCD.

2) Timing diagram

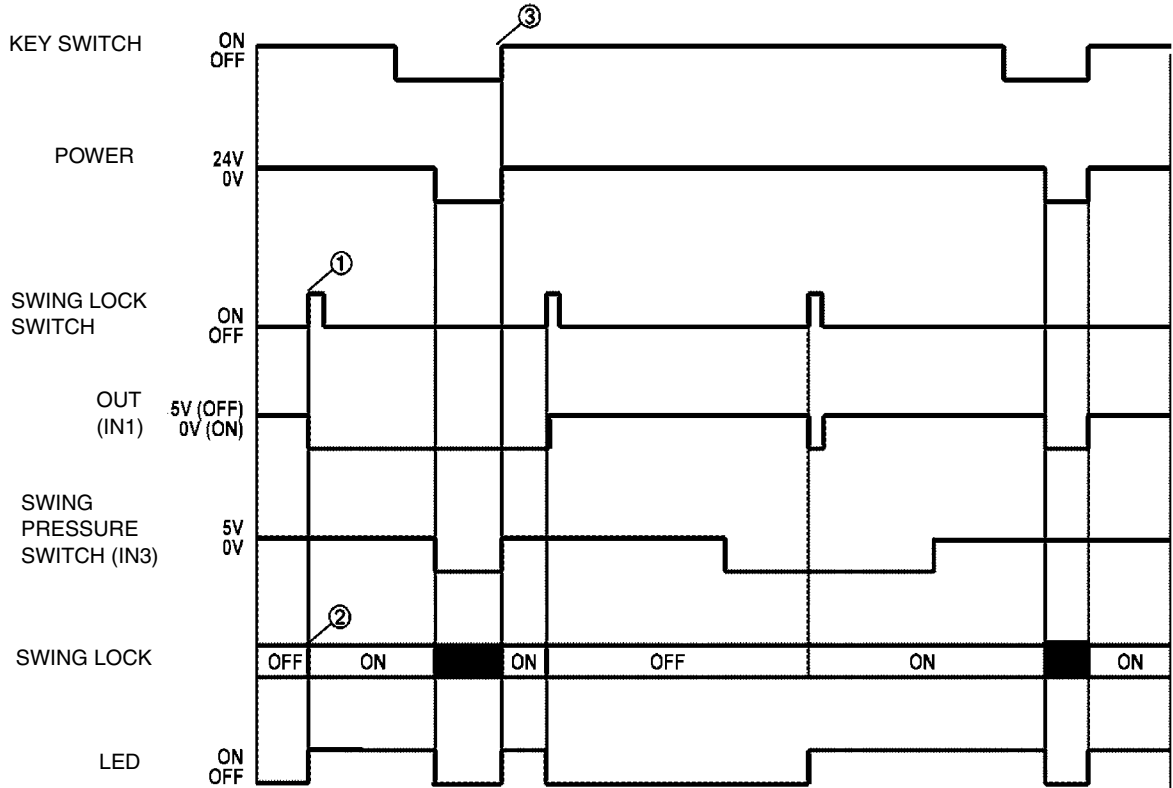

700-1-04-01-23 BT2

3) Swing brake auto control

1) Overview

The auto control of the swing brake takes place when the swing lock is OFF.

The auto control also releases the mechanical brake automatically during a digging operation as well as during swing operation. If the operation is halted, the auto control turns on the mechanical brake automatically.

The detailed conditioning for ON/OFF of the swing mechanical brake is shown below.

- The swing brake will be turned OFF based on the following conditions.
 1. Pressure switch (swing) is ON
 2. $P1 > 15 \text{ MPa}$ (2175 psi) or $P2 > 15 \text{ MPa}$ (2175 psi)
- The swing brake will be turned ON based on the following conditions.
 1. Pressure switch (attachment) stays OFF for 5 seconds
 2. Key switch is OFF
- The swing mechanical brake will be deactivated once when the pump delivery pressure (P1 or P2) grows over 15 MPa (2175 psi) during travel. However, it will take effect in 5 seconds.

4. Reversing fan control

Flowing direction of air is reversed by reversing fan revolution so that trifling dust clogged in the radiator core is possible to be removed.

Since heat radiation capacity declines while the fan rotation is being reversed by which overheat of the engine becomes possible, do not operate any control lever.

Change over of mode

1) Outline

- 1) Turning ON fan reversing switch (momentary) after the key switch has been turned ON allows the fan to change rotation from normal mode to reverse mode. During this period, the buzzer gives warning sound of 2Hz from the monitor to inform that the fan is rotated in reverse mode. When the reversing switch is turned ON again, it changes rotation from reverse to normal and the buzzer stops sounding.
- 2) For reverse mode, previous data are to be reset. This means that turning OFF the key switch in either of mode, reverse or normal, allows it to be operated in normal mode when the key switch is turned ON next time.
- 3) When warning message «OVER HEAT» is displayed on the monitor, it will not be operated in reverse mode. The fan reversing switch functions and the mode can be switched over after overheated condition is released and warning message «OVER HEAT» is disappeared from the monitor.
- 4) When the message «ELEC PROBLEM» is displayed on the monitor due to functioning of «power transistor protection», it will not be operated in reverse mode as stated above.

2) Time chart

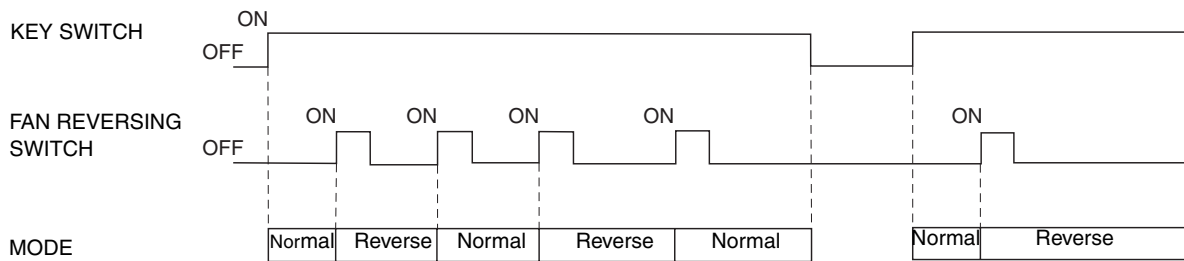

700-1-04-01-23CG

ACCESS AND CONTENTS OF MONITOR DISPLAYS (Diagnostic mode)

Access to monitor displays

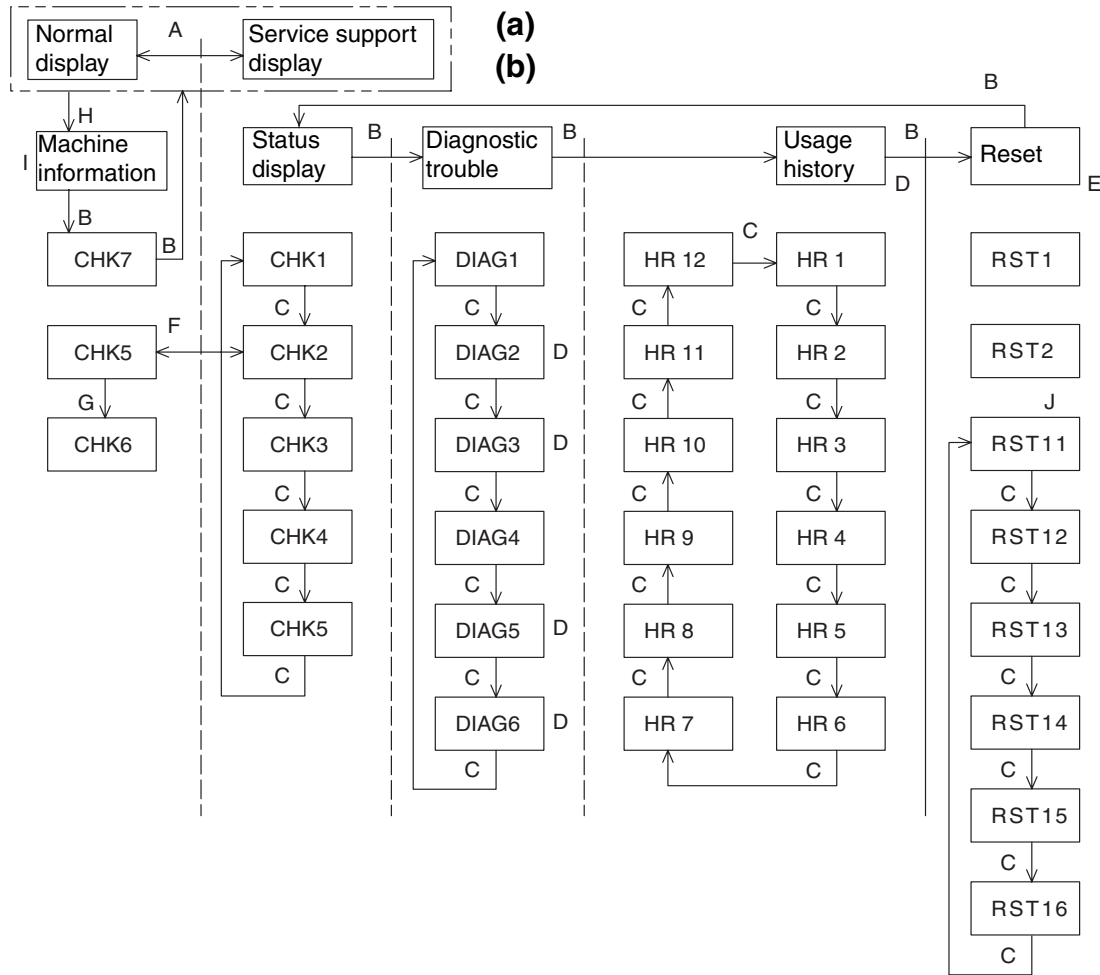

800.1.04.04.08A

a) Bar graph (Hydraulic oil temperature, coolant temperature, fuel level)

b) Mode (Travel, work, auto, idle)

Operating Switches

- To be switched after the travel & work mode switch has been turned ON for more than 3 seconds.
- To be switched when the auto mode switch is turned ON.
- To be switched when the buzzer stop switch is turned ON.
- Data is to be cleared after the work mode switch has been turned ON for more than 10 seconds (buzzer sounds when the data have been cleared).
- Reset function is to be selected when the buzzer stop switch is turned ON, the selected function is to be reset when the travel mode switch is turned ON, and the data are to be reset after the work mode switch has been turned ON for more than 10 seconds (buzzer sounds when the data have been reset).
- Output with the protection circuit actuated is to be checked when the travel mode switch is turned ON.
- Automatic detection of short circuit is to be indicated after the travel mode switch has been turned ON for more than 10 seconds.
- To be switched after the auto mode switch has been turned ON for more than 10 seconds.
- Selected machine model is to be cleared after the auto mode switch has been turned ON for further 10 seconds (buzzer sounds when it has been cleared).
- To be switched after the one-touch idle switch has been turned ON for more than 10 seconds at anytime while the service support screen is being displayed.

5. Screen HR5

HR 5	MODE II.H	4	0	0	0	0
	1	0	0	0	0	0
	2	0	0	0	0	0
	3	0	0	0	0	0
	5	0	0	0	0	0
	6	0	0	0	0	0
	7	0	0	0	0	0

[P2 pressure distribution]

- 1 : Time P2 10 MPa or less
- 2 : Time P2 10 to 15 MPa
- 3 : Time P2 15 to 20 MPa
- 4 : Time P2 20 to 25 MPa
- 5 : Time P2 25 to 30 MPa
- 6 : Time P2 30 to 35 MPa
- 7 : Time P2-35 MPa

6. Screen HR6

HR 6	MODE II.H	4	0	0	0	0
	1	0	0	0	0	0
	2	0	0	0	0	0
	3	0	0	0	0	0
	5	0	0	0	0	0
	6	0	0	0	0	0
	7	0	0	0	0	0

[Engine speed distribution]

- 1 : Time N 1175 min⁻¹ or less
- 2 : Time N 1175 to 1375 min⁻¹
- 3 : Time N 1375 to 1575 min⁻¹
- 4 : Time N 1575 to 1775 min⁻¹
- 5 : Time N 1775 to 1975 min⁻¹
- 6 : Time N 1975 to 2175 min⁻¹
- 7 : Time N 2175 min⁻¹ or more

7. Screen HR7

HR 7	MODE II.H	4	0	0	0	0
	1	0	0	0	0	0
	2	0	0	0	0	0
	3	0	0	0	0	0
	5	0	0	0	0	0
	6	0	0	0	0	0
	7	0	0	0	0	0

[Coolant temperature distribution]

- 1 : Time TW 77°C or less (Marks 1 and 2 on the bar graph)
- 2 : Time TW 77 to 82°C (Mark 3 on the bar graph)
- 3 : Time TW 82 to 97°C (Mark 4 on the bar graph)
- 4 : Time TW 97 to 100°C (Mark 5 on the bar graph)
- 5 : Time TW 100 to 103°C (Mark 6 on the bar graph)
- 6 : Time TW 103 to 105°C (Mark 7 on the bar graph)
- 7 : Time TW 105°C or more (Mark 8 on the bar graph)

8. Screen HR8

HR 8	MODE II.H	4	0	0	0	0
	1	0	0	0	0	0
	2	0	0	0	0	0
	3	0	0	0	0	0
	5	0	0	0	0	0
	6	0	0	0	0	0
	7	0	0	0	0	0

[Hydraulic Oil temperature distribution]

- 1 : Time TO 45°C or less (Marks 1 and 2 on the bar graph)
- 2 : Time TO 45 to 60°C (Mark 3 on the bar graph)
- 3 : Time TO 60 to 80°C (Mark 4 on the bar graph)
- 4 : Time TO 80 to 88°C (Mark 5 on the bar graph)
- 5 : Time TO 88 to 95°C (Mark 6 on the bar graph)
- 6 : Time TO 95 to 98°C (Mark 7 on the bar graph)
- 7 : Time TO 98°C or more (Mark 8 on the bar graph)

Entering injector ID code (after injector has been replaced)

RST	MODE Lo,S	4	6	B	1	8
11						
1	5	5	3	A	5	3
2	3	6	1	F	6	5
3	1	9	4	4	7	4

MODE Hi : Upper 2 places of figure on each line

MODE Lo : Lower 2 places of figure on each line

553A	6B18	Injection ID code
361F	3017	
1944	5200	
0000	4F	

800.1.04.04.08L.2

- 1 Select the replaced injector number 1 (RST11) with the buzzer stop switch.
- 2 Each time the auto mode switch is turned ON, 2 places of figure to be selected will shift in the order of "1Hi → 1Lo → 2Hi → 2Low → 3Hi → 3Lo → 4Hi → 4Lo → 5Hi → 5Lo → 6Hi → 7Hi → 1Hi . . ." (Selected line will change from "light-on-dark" to "dark-on-light" indication.)
- 3 Keep on entering the ID code and enter lower 2 places of figure on 2nd line here. (At this time, the 2nd line is indicated "light-on-dark" and the mode shows "Lo".) For setting the upper place of 2 places, since the figure shifts in the order of "0 → 1 → 2 . . . 9 → A → B → C → D → E → F → 0 . . ." each time the travel mode switch is turned ON, select "1" here. For setting the lower place of 2 places, since the figure shifts in the order of "0 → 1 → 2 . . . 9 → A → B → C → D → E → F → 0 . . ." each time the travel mode switch is turned ON, select "F" here.
- 4 Check that any line does not indicate "light-on-dark" after completion of entering all ID codes by repeating steps 2) and 3) above, then turn the work mode switch ON for more than 10 seconds to allow data communication with the engine controller (ECM). The buzzer sounds when the data have been written correctly.

NOTE : The buzzer will not sound in case where any one of figures has been mistakenly entered. When the key is turned OFF without sounding the buzzer, the ID codes already memorized remain unchanged.

- 5 Turn OFF the key switch.
- 6 Access the engine information setting screen again to check that the data have been rewritten correctly.

CLICK HERE TO **DOWNLOAD** THE COMPLETE MANUAL

- Thank you very much for reading the preview of the manual.
- You can download the complete manual from: www.heydownloads.com by clicking the link below



- Please note: If there is no response to CLICKING the link, please download this PDF first and then click on it.

CLICK HERE TO **DOWNLOAD** THE COMPLETE MANUAL

Overheating (continued)

Troubleshooting	Cause	Action
<p>2. The hydraulic temperature bar-graph displays 8 bars. Key switch ON</p> <p>The hydraulic oil temperature sensor (B2) temperature is abnormal compared to maintenance assistance CHK1 (comparison between the actual temperature and that indicated). See hydraulic oil temperature in CHK1 OT. Measure the actual temperature</p> <p>YES</p> <p>See problem code M0020 for the oil temperature sensor (B2) using maintenance diagnostic (DIAG 4)</p> <p>YES</p> <p>Disconnect connector CND3 on the hydraulic oil temperature sensor (B2) to measure the resistance. (Refer to the table below for the resistance).</p> <p>NO</p> <p>Disconnect the CN23 connector to measure the resistance between the male terminals OL and BO. (Refer to the table below for the resistance).</p> <p>YES</p> <p>OUI</p> <p>Disconnect connector CN1 to measure the resistance between the female terminals OL and BO. (Refer to the table below for the resistance).</p> <p>NO</p> <p>YES</p>	<p>Defective hydraulic oil temperature sensor (B2)</p> <p>Bad connection on the hydraulic oil temperature sensor connector (B2)</p> <p>Bad connections on CN23</p> <p>Defective computer/controller (A1) or bad connection on CN1</p>	<p>Replace the hydraulic oil temperature sensor (B2)</p> <p>Clean the hydraulic oil temperature sensor connecting terminal (B2)</p> <p>Clean the connecting terminal on CN23</p> <p>Replace the computer/controller (A1) or clean the connecting terminals on CN1</p>
<p>Note: In the event of a short-circuit, the bar-graph goes off completely.</p>		

Section

8001

**SPECIFICATIONS, TROUBLESHOOTING,
INSPECTIONS AND HYDRAULIC PRESSURE SETTING**

CHECKING AND SETTING PROCEDURE

Location of secondary relief valves

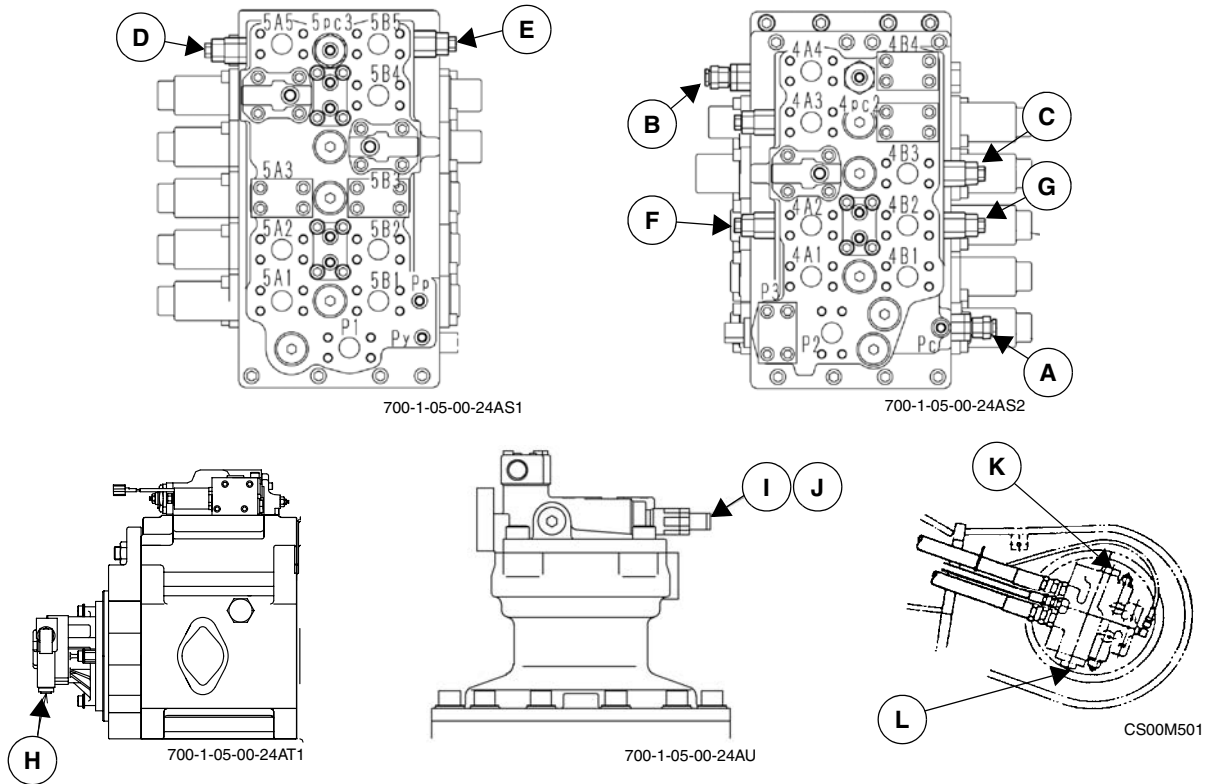

Item	Description	Tool used		Set pressure	Pressure for 1 turn of the screw (or for 1 shim*)
		Look nut	Adjusting screw		
A	Main relief (standard pressure)	30 mm	22 mm	4554 psi	2553 psi
	Main relief (power boost)	41 mm	27 mm	4975 psi	
B	Boom raising port secondary relief	13 mm	Hexagon wrench 4 mm	5265 psi	xxx psi
C	Boom lowering port secondary relief				xxx psi
D	Dipper out port secondary relief				xxx psi
E	Dipper in port secondary relief				xxx psi
F	Bucket open port secondary relief				xxx psi
G	Bucket close port secondary relief				xxx psi
H	Pilot circuit main relief				24 mm
I	RH swing port secondary relief	38 mm	30 mm	3843 psi	638. psi
J	LH swing port secondary relief				
K	Reverse travel secondary relief			xx psi	xx psi
L	Forward travel secondary relief				

HYDRAULIC FUNCTIONS

List of functions

Functions	Description	Pages
Travel Circuits		
High speed travel circuit	High speeds can be achieved by setting the two-step inclinatory angle of the travel motor to the smaller angle side. Load pressure applied to the travel motor automatically changes the speed to a lower one. Travel load pressure does not control the controller.	Page 6
Low speed travel circuit	Low speeds can be achieved by setting the two-speed inclinatory angle of the travel motor to the larger angle side.	Page 8
Straight travel circuit	Maintains machine's straight travel even when attachment or swing operations are performed during its travel.	Page 10
Swing Circuits		
Swing parking circuit	When the swing lever is in neutral, the swing parking is activated and the swing is fully held. When the swing lever is operated, the parking brake is released by signals from the pressure switch. When the swing lever is in neutral, the parking brake is released by load pressure generated by attachment operation. The parking brake starts to operate 5 seconds after the swing lever comes in neutral and after the load pressure has become lower than the specified values. When the swing lock switch is turned on, the parking brake starts to operate. At the same time, pilot pressure works on both ends of the swing spool.	Page 12
Swing push digging	When swinging and arm operation are conducted simultaneously, swing pushing function can be obtained by the swing override throttle valve integrated in the control valve.	Page 16
Free swing operation	An orifice leak is opened between the A and B ports of the swing motor. This will provide smoother starts and stops of the swing during hoisting operation.	Page 18
Vibration backlash	The reversal prevention valve attached to the swing motor reduces backlashes that occur when the swing stops	
Arm (Dipper) Circuits		
Arm-out circuit	Switching over arm (1) and (2) spools makes hydraulic oil flows merge, achieving faster speed.	Page 18
Arm-in load holding	Load holding valve integrated in the control valve reduces natural drop on the arm-in side. Arm-in pilot pressure enables arm-in operation by releasing the load holding valve.	Page 20
Arm-in circuit	The regenerative circuit and forced regenerative release valve in the arm (1) spool function achieves faster arm speed.	Page 22
Boom Circuits		
Boom-up circuit	Switching over boom (1) and (2) spools makes hydraulic oil flows merge, achieving faster speed. When operating in combination with the bucket, flow rate to the boom side is secured by the priority valve for boom.	Page 24
Boom-down load holding	Load holding valve integrated in the control valve reduces natural drop of the boom. Boom-down pilot pressure enables boom-down operation by releasing the load holding valve.	Page 28

Swing Parking Circuit (Lever in Neutral / Swing Locked)

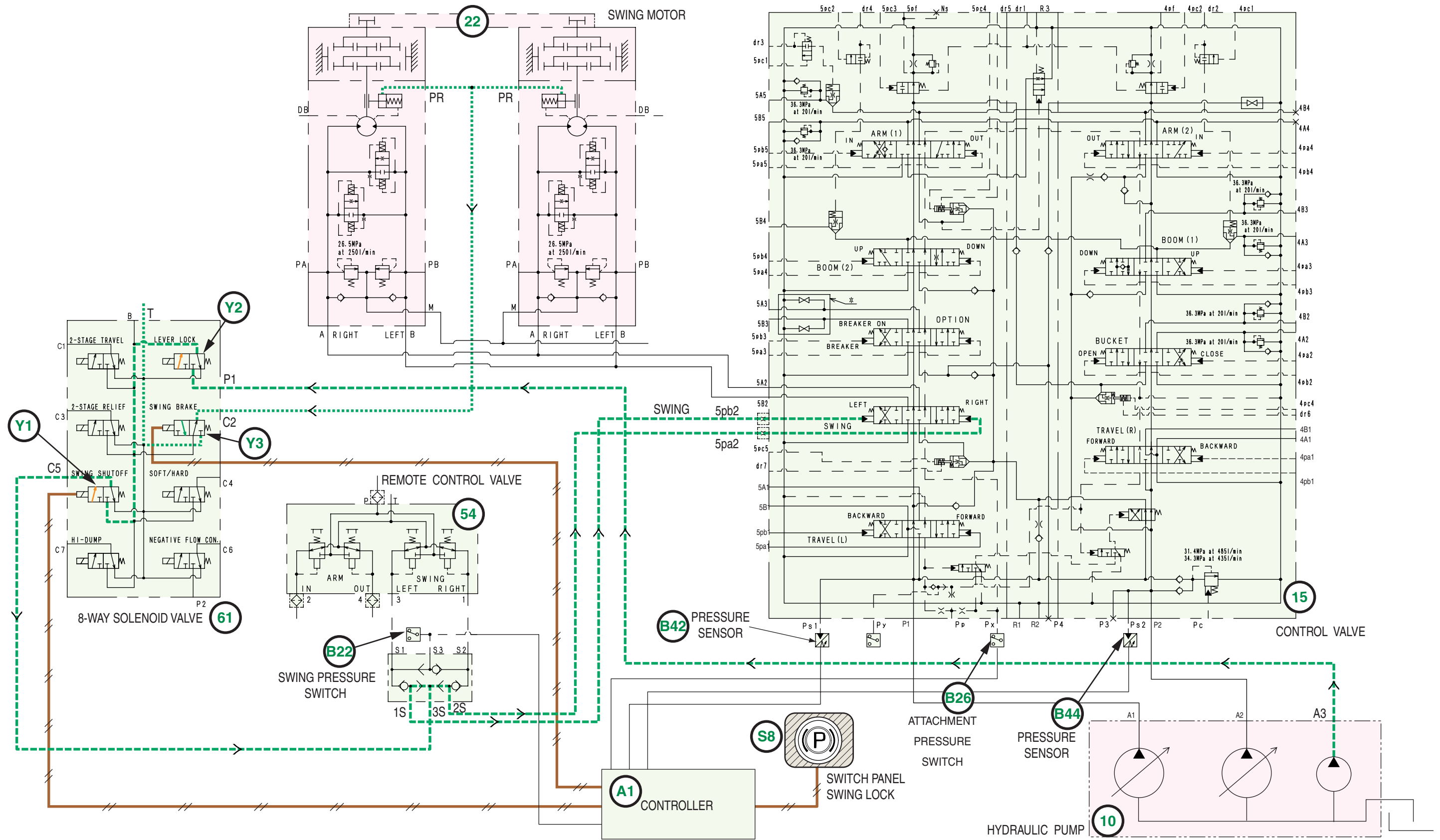

Arm-In Load Holding

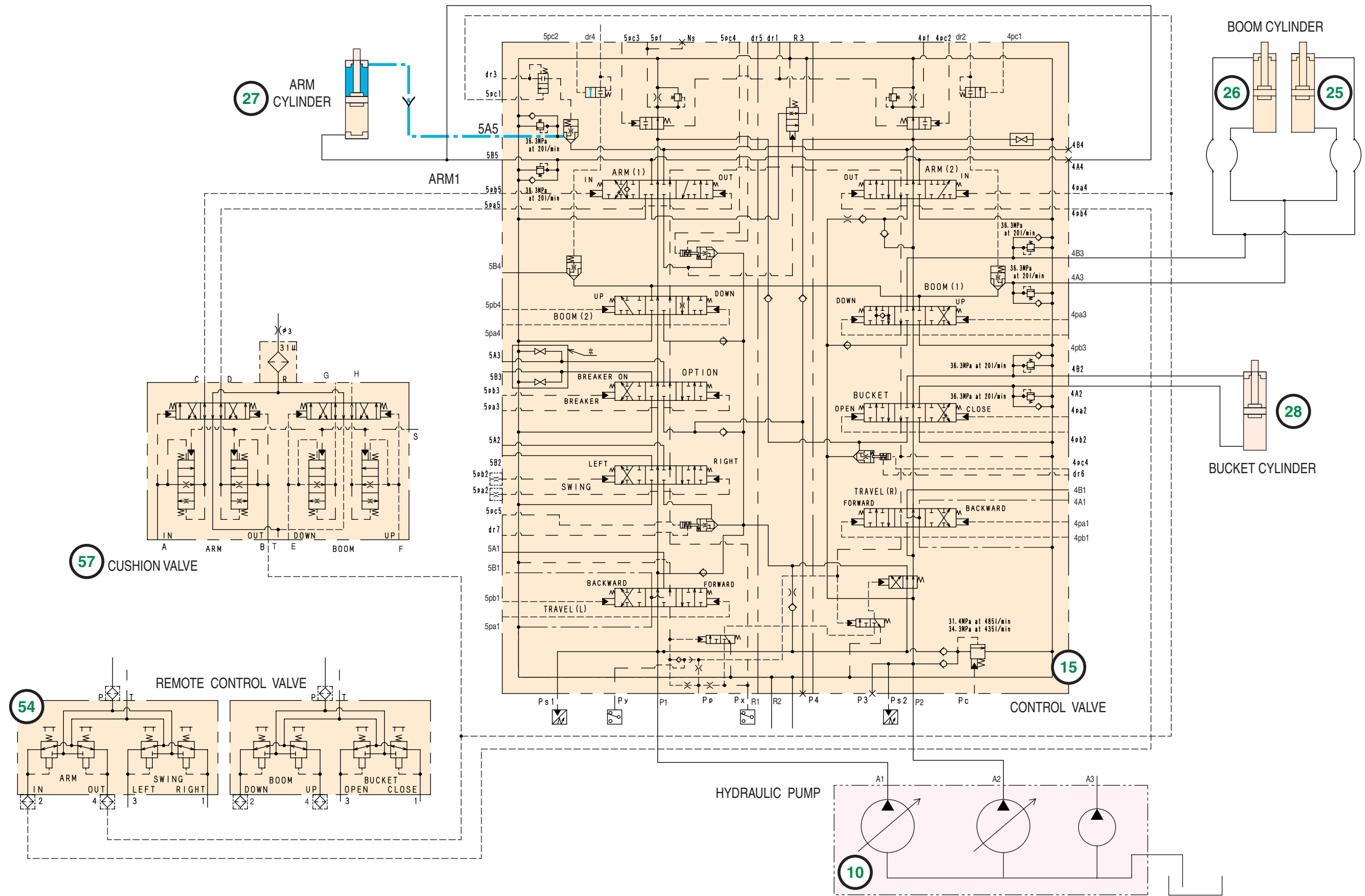

Boom-Down Circuit

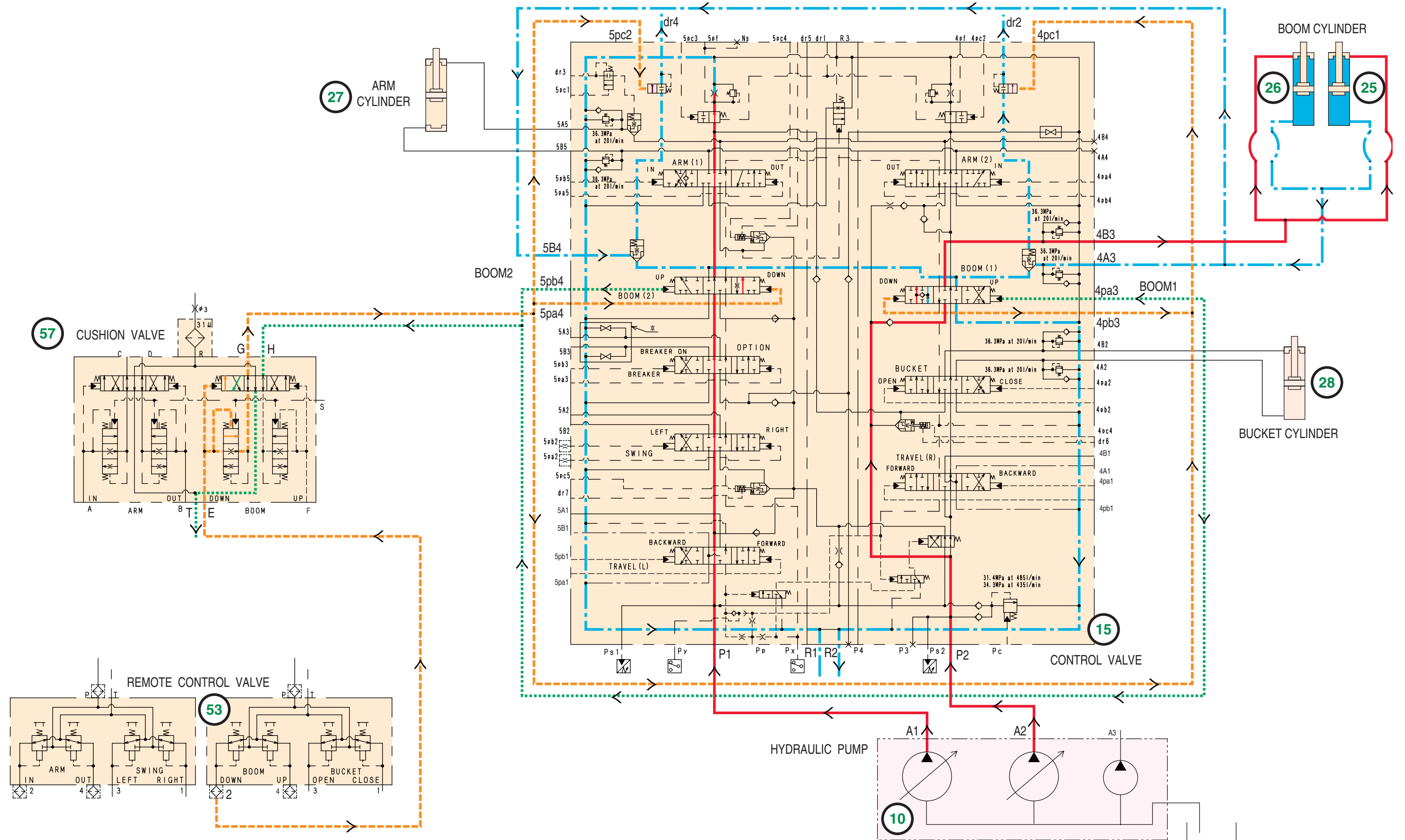

HYDRAULIC PUMP

Operation Principle

The rotary group consists of the drive shaft F (111), cylinder block (021), piston (151), shoe (152), retainer (153), spherical bush (156), and cylinder spring (157). The drive shaft's ends are supported by the bearing (123, 124). The shoe forms a spherical joint caulked by the piston. It contains a pocket area in order to reduce the thrust force, which is generated by the loading pressure, and slide lightly on the shoe plate (211). The sub group of the piston shoe is pressed on the shoe plate by the cylinder spring via the retainer and spherical bush in order to move smoothly on the shoe plate. The cylinder block is also pressed on the valve plate (313) by the cylinder spring.

The swash plate group consists of the swash plate (212), shoe plate (211), swash plate support (251), tilting bush (214), tilting pin (531), and servo piston (532). The swash plate is supported on the swash plate support by the cylindrical part formed on the opposite side of the shoe sliding side.

When the servo piston moves to the right and left due to the regulator controlling hydraulic force being led to the hydraulic compartment, the swash plate is able to swing the swash plate support and change the tilting angle (α) via the spherical part of the tilting pin. The hydraulic compartment is located on the both sides of the servo piston.

The valve block group consists of the valve cover (311,312), booster (130), spline coupling (114), valve plate (313, 314), and valve plate pin (885). Spline coupling connects both drive shafts (F) and (R) between valve covers (F) and (R) to transfer torque. Booster is connected to the spline coupling and functions to pressurize suction pressure by centrifugal force for raising the suction capacity. The valve plate which has two claw shaped ports installed on the valve block. It feeds and collects oil from the cylinder block. Oil which is switched by the valve plate flows to the external pipe through the valve block.

When the drive shaft is driven by the motor (electric motor, engine, or others), the cylinder block rotates simultaneously via the spline connection. If the swash plate is leaned, the piston located inside the cylinder block rotates with the cylinder block and exerts the reciprocal motions in relation to the cylinder correspondingly. Therefore, when focusing on one specific piston. In one full rotation, the piston moves toward the direction which is leaving apart from the valve plate (process of intake oil) during the first 180 degrees, and moves toward the direction which is coming to the valve plate (process of discharging oil) during the remaining 180 degrees. When the swash plate's angle is 0 degrees, the piston does not stroke, and therefore, oil will not be discharged.

Description

NO.	PART NAME	QTY	COUNSTITUENT PART(QTY)
4	GEAR PUMP	1st	ZX15LHRZ1
11	PISTON ASSY	2st	151(9PC),152(9PC)
13	CYLINDER (R) ASSY	1st	012(1PC),313(1PC)
14	CYLINDER (L) ASSY	1st	012(1PC),314(1PC)
30	SWASH PLATE ASSY	2st	212(1PC),214(1PC)
530	TILTING PIN ASSY	2st	531(1PC),548(1PC)

NO.	PARTNAME	QTY	NO.	PARTNAME	QTY	NO.	PARTNAME	QTY
111	DRIVE SHAFT (F)	1	311	VALVE COVER (F)	1	710	O-RING	2
113	DRIVE SHAFT (R)	1	312	VALVE COVER (R)	1	717	O-RING	4
114	SPLINE COUPLING	1	313	VALVE PLATE (R)	1	718	O-RING	1
115	COUPLING	1	314	VALVE PLATE (L)	1	724	O-RING	19
123	ROLLER BEARING	2	401	HEX.SOCKET HEAD BOLT	4	725	O-RING	2
124	NEEDLL BEARING	2	402	HEX.SOCKET HEAD BOLT	4	728	O-RING	2
127	BEARING SPACER	4	406	HEX.SOCKET HEAD BOLT	4	732	O-RING	2
130	BOOSTER	1	407	HEX.SOCKET HEAD BOLT	4	774	OIL SEAL	1
012	CYLINDER BLOCK	2	415	HEX.SOCKET HEAD BOLT	2	789	BACK-UP RING	2
151	PISTON	18	416	HEX.SOCKET HEAD BOLT	4	792	BACK-UP RING	2
152	SHOE	18	466	PLUG	2	808	NUT	4
153	RETAINER	2	468	PLUG	4	824	STOP RING	2
156	SPHERICAL BUSH	2	490	PLUG	31	825	LOCKING RING	1
157	CYLINDER SPRING	18	491	RESTRICTOR	4	885	VALVE PLATE PIN	2
211	SHOE PLATE	2	492	PLUG	5	887	SPRING PIN	5
212	SWASH PLATE	2	531	TILTING PIN	2	901	EYE BOLT	2
214	TILTING BUSH	2	532	SERVO PISTON	2	953	SET SCREW	2
251	SWASH SUPPORT PLATE	2	534	STOPPER (L)	2	954	SET SCREW	2
253	WASHER	8	535	STOPPER (S)	2	956	SET SCREW	8
261	FRONT COVER	1	548	FEED BACK PIN	2	981	NAME PLATE	1
263	REAR COVER	1	702	O-RING	2	983	PIN	2
271	PUMP CASING	2	706	O-RING	1			

[2] When the plunger operates.

1) Boom up [$P_v > P_c$] (4pc1 Pilot signal: OFF)

The plunger moves to the right and the oil in the high pressured oil passage enters into the room [3]. Being the room [1] is connected to the room [2] through the throttle [4], the pressure here is equal in the P_c and the puppet C opens by the pressure P_v , and the oil in the high pressured oil passage is supplied to the cylinder head side.

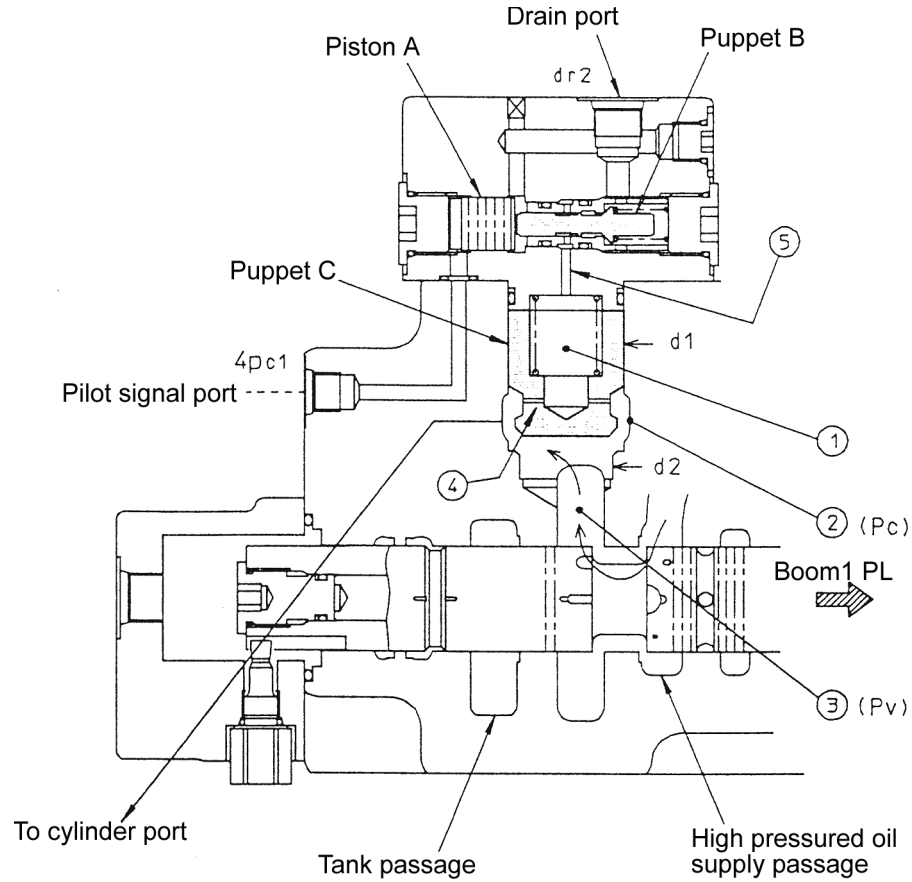

3. Relief Valve (Refer to fig. 2)

[1] Consider the P port is pressurized by the tank pressure, There are initial pressure acting on P,R ports as showing on fig. 2-A).

The relief valve begin to work under the summary of the force by multiplying of the pressurized area (A1) of the plunger (301) and the pressure P, the spring (321) force, the pushing force to the plunger (301) by the pressure of "g" chamber (Pg). First, the pressure of "g" chamber remains certain value during the period that the piston 2 (303) begins moving and ends stroking, P remains the low pressure as P2. Next, the spring (321) force gets stronger during the period that the piston 1 (302) is moving, P raises gradually.

According to such action, raise of the relief pressure P is controlled by the pressure raising time t1 from P1 to Ps. The sequent is shown on fig. 2-B) to D), the following explain the relation between the moving condition of each part and the relief pressure.

[2] Status showing on fig. 2-B)

The P port is pressurized and the pressure in "g" chamber is produced with action from restriction "m" inside the plunger (301). This pressure acts on the pressurized area (A2-A3) of the piston 2 (303), the right forward force and the spring (322) force produce the pressure (Pg1), the plunger (301) moves to right. The relationship shows on the next diagram.

$P1 \times A1 = Fsp1 + Pg1 \times A2$ Fsp1: the initial set force of the spring (321).

During raising of the piston 2 (303), the exhausting oil of the dumping chamber h exhaust from the R port side with acting of the slit around the piston 2.

[3] Status showing on fig. 2-C)

After the piston 2 (303) reaches the stroke end, the force caused by the pressure in "g" chamber acting on the pressurized area A4 of the piston 1 (302) overcomes the spring (321) force, the piston 1 (302) begins to move.

When the moving of the piston 1 (302) begins, the f chamber acts to the dumping chamber with the adjusting plug (401) and the exhausting shaft setting on the sliding part of the piston 1 (302). So that the pressure of "g" chamber raises smoothly until the piston 1 (302) reaches the end of adjusting plug (401). Also, the spring (321) is pressed, the deflection increases, the installation load expands.

The relief pressure P raises smoothly from P2 to Ps.

[4] Status showing on fig. 2-D)

To stop the piston 1 (302) from moving left beyond the end of the adjusting plug (401), the pressure of "g" chamber is Ps, as well as the relief pressure. The normal relief operation is under such status.

As per the above sequence of [1] to [4], the relief pressure varies as fig. 2-E).

The following explain the action during relief pressure reduction.

When there is no additional pressure acting to the P port, the P port pressure as well as the "g" chamber pressure drop to the tank pressure. So that the opening plunger (301) moves left and sets on the seat (341). In the meantime, the piston 1 (302) is moved right by the spring and back to formal status. Also the piston 2 (303) is moved left by the spring and turned back. In this case, the ball check valve installed above is opening, oil supplied from R port, the piston 2 (303) is made with a slow returning structure.

4. Operation of Forward / Reverse Changeover Valve

[1] When ON-OFF solenoid for changeover valve is demagnetized

- When ON-OFF solenoid for changeover valve [1] is demagnetized, pressure oil from the pump is shut off by ON-OFF changeover valve [2] allowing port C to lead to the tank circuit.
- This allows the changeover spool [3] to be pushed to the right by the changeover spool spring [4] and the motor port MA opens to let the pressure oil flow in and as a result the motor makes forward rotation (CW).

[2] When ON-OFF solenoid for changeover valve is magnetized

- When ON-OFF solenoid for changeover valve [1] is magnetized, ON-OFF change over valve [2] switches over and pressure oil from the pump enters in the port C to let it flow into the chamber D.
 - Pressure oil in the chamber D overcomes the changeover spool spring [4] to push the changeover spool [3] to the left.
- This allows the motor port MB to open and pressure oil flows in and as a result the motor makes reverse rotation (C.C.W.).

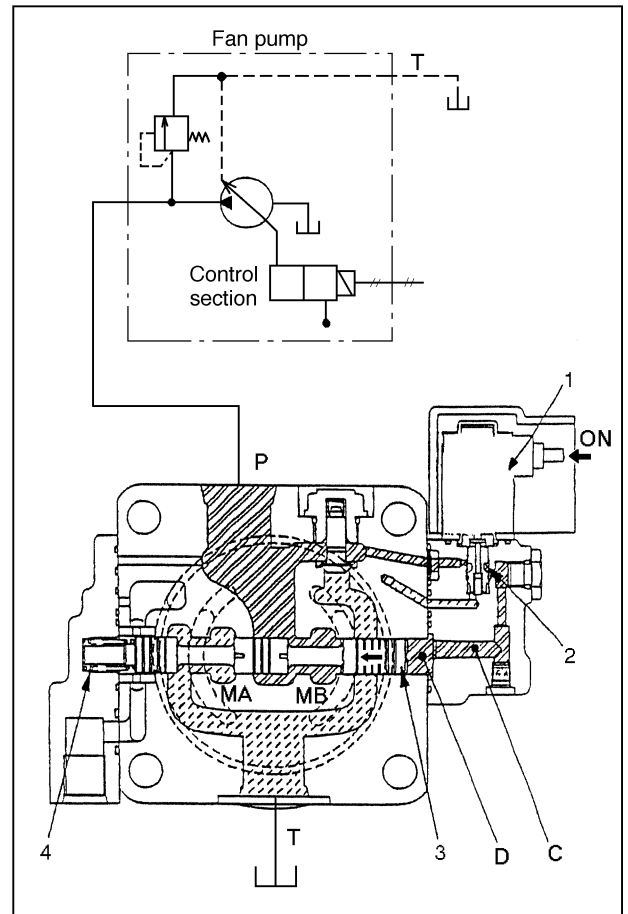
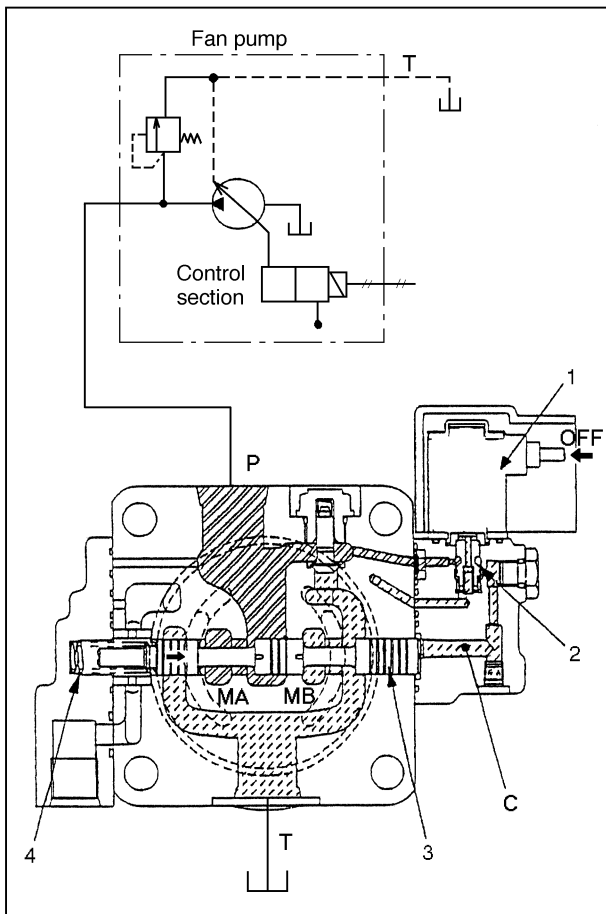

Overall layout

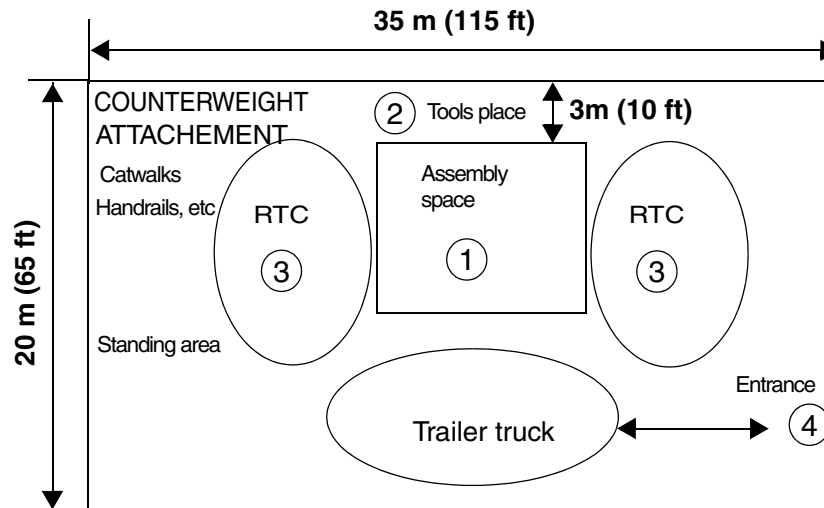

NOTE:

1. Space for assembling needs 6.5 x 8 m (22x27 ft).
2. Compound plywood is placed in the area for tools and jigs for preventing dirt and dust.
3. Rough terrain crane (RTC) must extend outriggers. RTC 45 T 2 sets (One set is for unloading the steel plates and setting the stools, another set is for setting the components).
4. Entrance/Exit is always clears from any obstacle to truck passage.

IMPORTANT : *The working area must have a warning sign reading «No person other than the concerned is authorized to enter this area».*

Fitting the lower piping covers

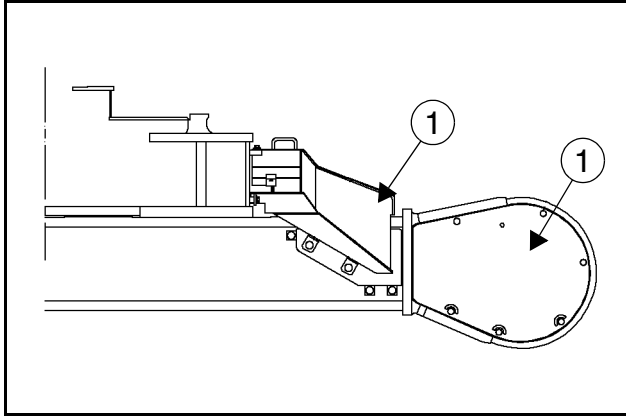

700-1-06-02-05E1

1. Fit the piping covers (1).
2. Apply Loctite to the screws. Tighten them to a torque of 137 Nm (101 lb-ft, 14 kgf.m).

Other fittings

- 1: Fit the catwalks
- 2: Fit the handrails.

MOUNTING THE COUNTERWEIGHT

Purpose

To mount the counterweight.

CAUTION : *No person must be present under the lifted counterweight.*

NOTE: *Tightening torque for the counterweight is 2256 to 2550 Nm (1664 to 1880 lb-ft, 230 to 260 kgf.m).*

CHECKING WORK

To check there is no abnormality on the machine after it is assembled

- | | |
|--|--|
| <ol style="list-style-type: none"> 1. Check the oil quantity at the transportation stage, and add oil if necessary.
200 litres drum
Hand pump (T29) 2. Grease
Grease pump (T30)
Grease gun (with 10 cartridge) | <ol style="list-style-type: none"> 3. Touch up the paint work
Wipe out dirt
Paint with a brush (T31)
Spray with a gun
Compressor (T3)
Set of painting tool 4. Front side of the right platform
Fitting handrails 5. Machine body check
Engine oil
Water
Reduction oil
Any other abnormal point 6. Operational check. |
|--|--|

OPERATIONAL TESTING AFTER ASSEMBLY WORK

1. Items to be attended to after assembly.
Actuate each actuator and the machine, with the engine at minimum speed.
When each actuator starts, check the correct movement direction by using the inching control with the control lever.
CAUTION : *When control for each movement starts, make sure no person is located around the machine.*
2. Procedure for operational testing and the items to be attended to after the assembling work is completed.

CLICK HERE TO **DOWNLOAD** THE COMPLETE MANUAL

- Thank you very much for reading the preview of the manual.
- You can download the complete manual from: www.heydownloads.com by clicking the link below



- Please note: If there is no response to CLICKING the link, please download this PDF first and then click on it.

CLICK HERE TO **DOWNLOAD** THE COMPLETE MANUAL