

**4608 / 4609 / 4610
TRACTOR
REPAIR TIME SCHEDULE**

Form Number 4283520M2

Contents

Section	Description
1	Accessories
2	Brake System
3	Cab
4	Chassis
5	Decals
6	Drive Train System
7	Electrical System
8	Engine, Fuel, and Exhaust System
9	Hydraulic System
10	Implement Lift System
11	Steering System

CLICK HERE TO **DOWNLOAD** THE COMPLETE MANUAL

- Thank you very much for reading the preview of the manual.
- You can download the complete manual from: www.heydownloads.com by clicking the link below



- Please note: If there is no response to CLICKING the link, please download this PDF first and then click on it.

CLICK HERE TO **DOWNLOAD** THE COMPLETE MANUAL

4608 / 4609 / 4610 UTILITY TRACTOR
ENGINE, FUEL AND EXHAUST SYSTEM

Item



Description

10

INLET AND EXHAUST MANIFOLD

1	72 05 09	2.0
9	72 65 03	1.0
12	72 06 00	2.75
13	72 65 00	2.75
14	52 05 13	0.75
19	59 23 07	1.0

EXHAUST MANIFOLD
INTAKE MANIFOLD GASKET
INTAKE MANIFOLD
INTAKE MANIFOLD GASKET
AIR PIPE
SOLENOID

SIS0225

SIS0225

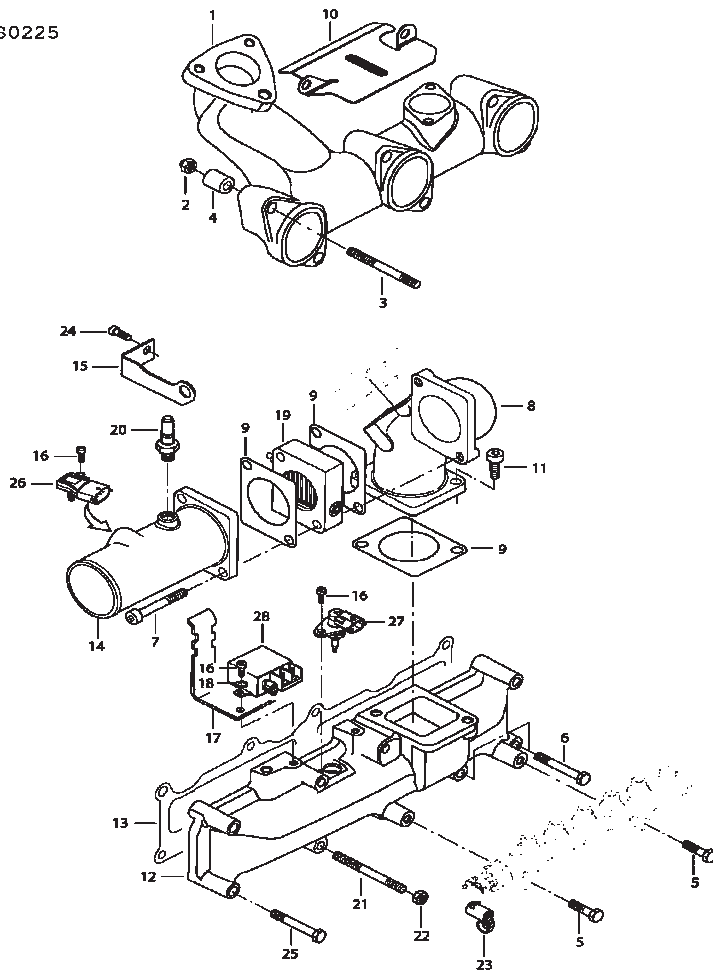

4608 / 4609 / 4610 UTILITY TRACTOR
ENGINE, FUEL AND EXHAUST SYSTEM

Item



Description

20

ALTERNATOR AND STARTER

MFC12836

1	59 06 00	1.0	ENGINE FAN
2	59 06 02	1.0	SPACER
3	59 22 00	1.0	PULLEY, WATERPUMP
6	58 10 00	0.5	FLYWHEEL ASSY.
7	58 36 00	0.5	RING GEAR
11	14 01 09	0.8	STARTER
13	14 01 02	1.0	GENERATOR

MFC12836

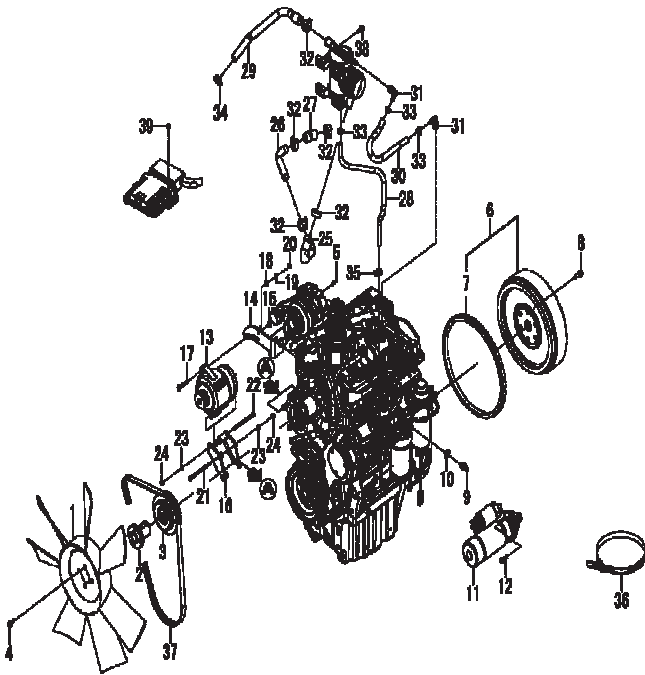

4608 / 4609 / 4610 UTILITY TRACTOR
STEERING SYSTEM

Item



Description

30

STEERING WHEEL

1	17 01 01	0.5	STEERING WHEEL
5	17 01 78	0.5	FRONT COVER
6	17 01 78	0.5	REAR COVER
8	17 01 31	1.0	STEERING SHAFT
9	17 01 64	1.0	U-JOINT

MFC12725

MFC12725

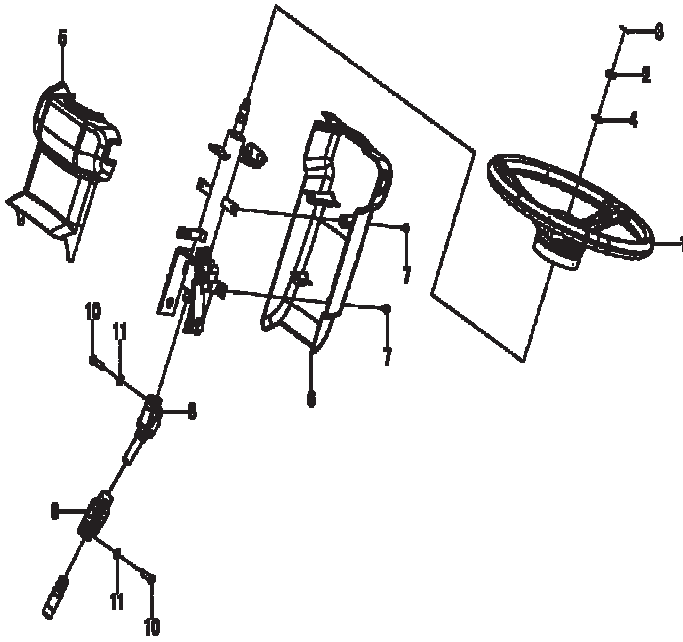

4608 / 4609 / 4610 UTILITY TRACTOR
DRIVE TRAIN SYSTEM

Item



Description

40

MAIN CLUTCH

1

58 37 00

6.5

FLYWHEEL DAMPENER

MFC12691

MFC12691

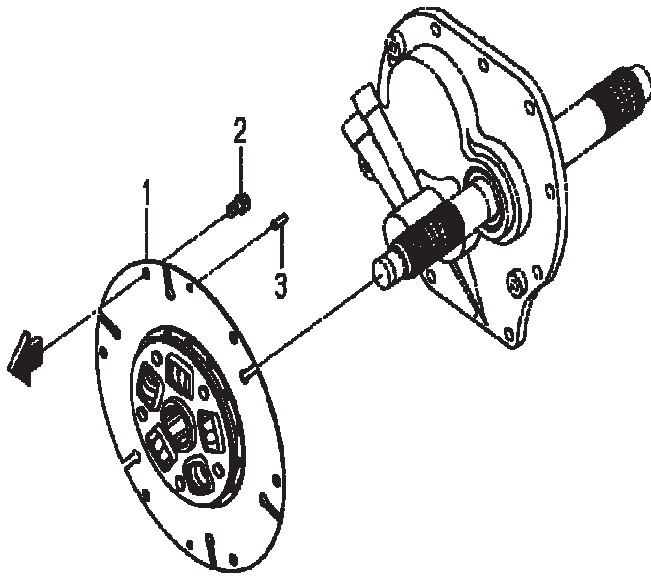

4608 / 4609 / 4610 UTILITY TRACTOR
DRIVE TRAIN SYSTEM

Item



Description

50

RANGE GEAR

MFC12703

1	19 02 27	15.0	GEAR
2	19 02 28	15.0	BUSHING
3	19 02 29	15.0	NEEDLE BEARING
4	19 02 30	15.0	COLLAR
5	19 02 31	15.0	GEAR HUB
6	19 02 32	15.0	COUPLING
7	19 02 33	15.0	SNAPRING
8	19 02 34	15.0	HELICAL GEAR
9	19 02 35	15.0	NEEDLE BEARING
10	19 02 36	15.0	WASHER
11	19 02 37	15.0	WASHER
12	19 02 38	15.0	PLATE

MFC12703

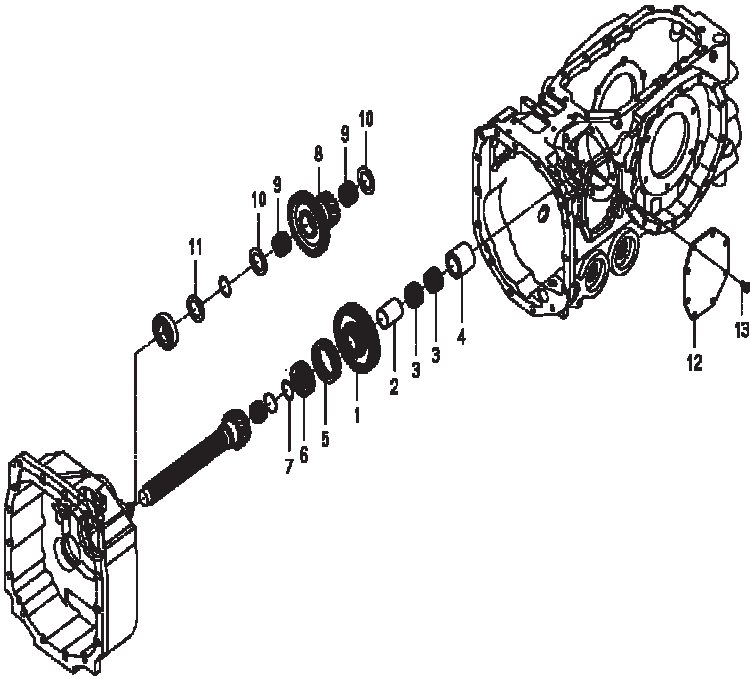

CLICK HERE TO **DOWNLOAD** THE COMPLETE MANUAL

- Thank you very much for reading the preview of the manual.
- You can download the complete manual from: www.heydownloads.com by clicking the link below



- Please note: If there is no response to CLICKING the link, please download this PDF first and then click on it.

CLICK HERE TO **DOWNLOAD** THE COMPLETE MANUAL

4608 / 4609 / 4610 UTILITY TRACTOR
DRIVE TRAIN SYSTEM

Item



Description

60

LEVER

1	17 01 75	1.5	LEVER BRACKET
5	17 01 75	1.5	ARM
9	19 10 07	0.2	LEVER ROD
10	19 10 02	0.1	HANDLE
13	19 10 07	0.2	LEVER ROD

MFC12715

MFC12715

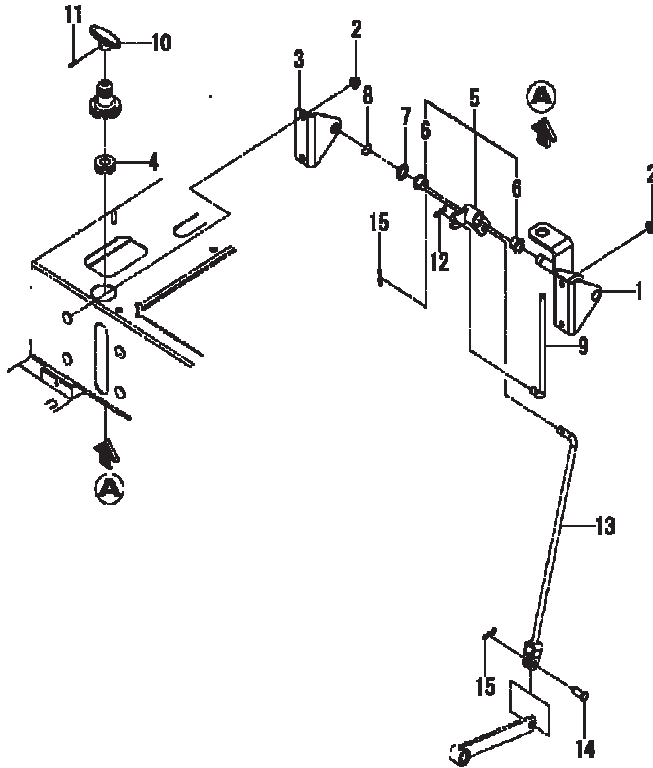

4608 / 4609 / 4610 UTILITY TRACTOR
HYDRAULIC SYSTEM

Item



Description

70

HYDRAULIC PUMP AND PLUMBING

23	22 01 26	1.5	RELIEF VALVE
24	22 01 26	1.5	RELIEF VALVE
29	22 04 30	1.0	PRESSURE HOSE
34	22 01 26	1.5	VALVE
37	22 06 13	1.5	LINE FILTER
40	22 01 26	1.5	SLOW RETURN VALVE
41	22 01 12	1.5	SLOW RETURN SHAFT
43	22 01 12	1.5	RETURN ROD
50	22 01 26	1.5	PRIORITY VALVE

MFC12746

MFC12746

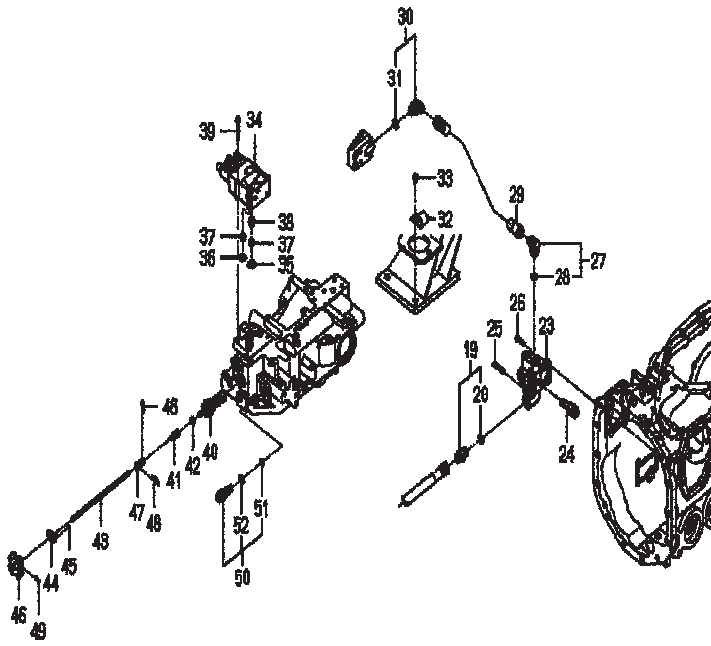

4608 / 4609 / 4610 UTILITY TRACTOR
ELECTRICAL SYSTEM

Item



Description

80

ENGINE ELECTRICAL

1	14 01 12	1.5	ENGINE HARNESS
2	14 01 12	1.5	ENGINE HARNESS
3	13 04 10	0.5	BATTERY TERMINAL
5	13 04 11	0.5	CABLE

MFC12782

MFC12782

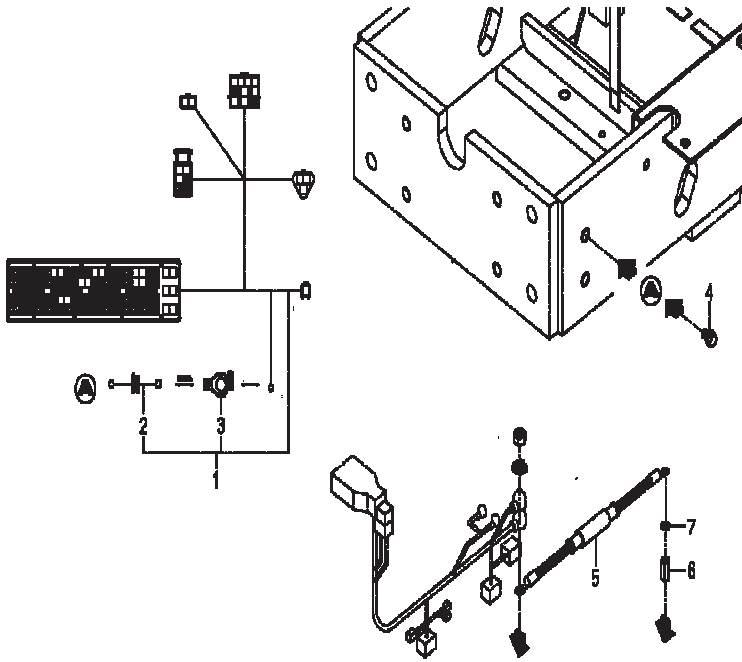

4608 / 4609 / 4610 UTILITY TRACTOR
ELECTRICAL SYSTEM

Item



Description

90

SWITCHES

1	60 39 00	0,5	HAZARD LIGHT SWITCH
3	60 39 00	0,5	SWITCH
4	60 39 00	0,5	SWITCH
5	60 39 00	0,5	SWITCH
9	60 39 00	0,5	SWITCH
10	14 04 66	0,5	BULB
11	14 01 36	0,5	SOCKET

MFC12792

MFC12792

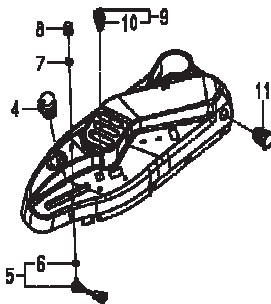
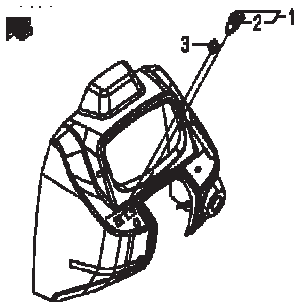

4608 / 4609 / 4610 UTILITY TRACTOR
CAB

Item



Description

100

CAB INTERIOR

MFC12804

- 1 28 03 28
- 5 28 03 28
- 6 28 03 28

- 1.5 FENDER COVER, LEFT HAND
- 1.5 COVER, LEFT HAND
- 1.5 COVER, RIGHT HAND

MFC12804

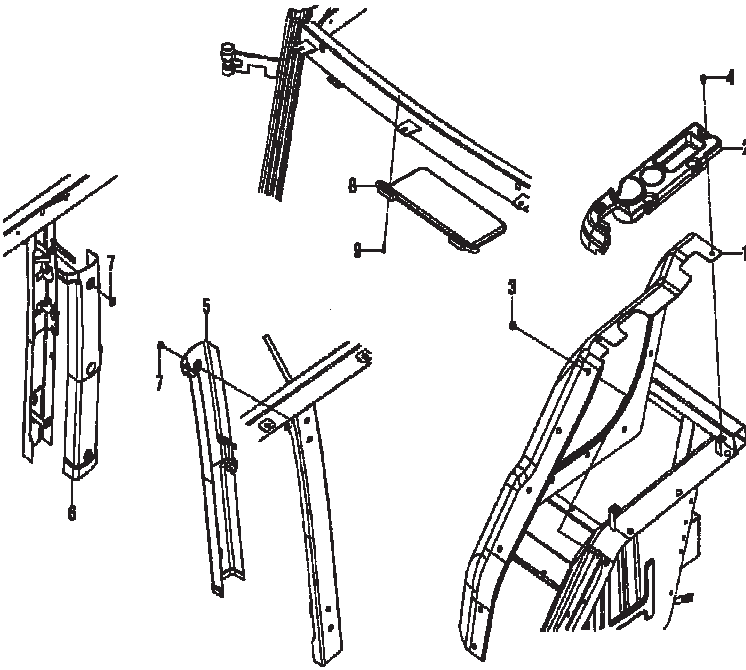

4608 / 4609 / 4610 UTILITY TRACTOR
CHASSIS

Item



Description

110

SEAT

1	26 06 00	0.2	OPERATORS SEAT
3	28 06 23	0.5	SEAT PANEL

MFC12770

MFC12770

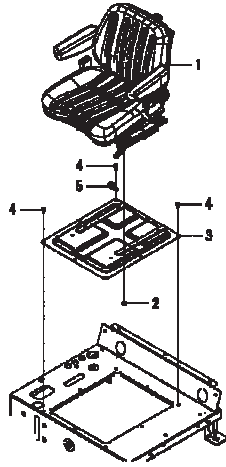

4608 / 4609 / 4610 UTILITY TRACTOR
DECALS

Item



Description

120

CHASSIS DECALS

1	28 02 22	0.25	DECAL, MASSEY FERGUSON
2	28 02 20	0.25	DECAL, MASSEY FERGUSON, LEFT HAND
3	28 02 20	0.25	DECAL, MASSEY FERGUSON, RIGHT HAND
4	28 00 47	0.25	DECAL, 4610
5	17 01 61	0.25	DECAL, STEERING

MFC12811

MFC12811

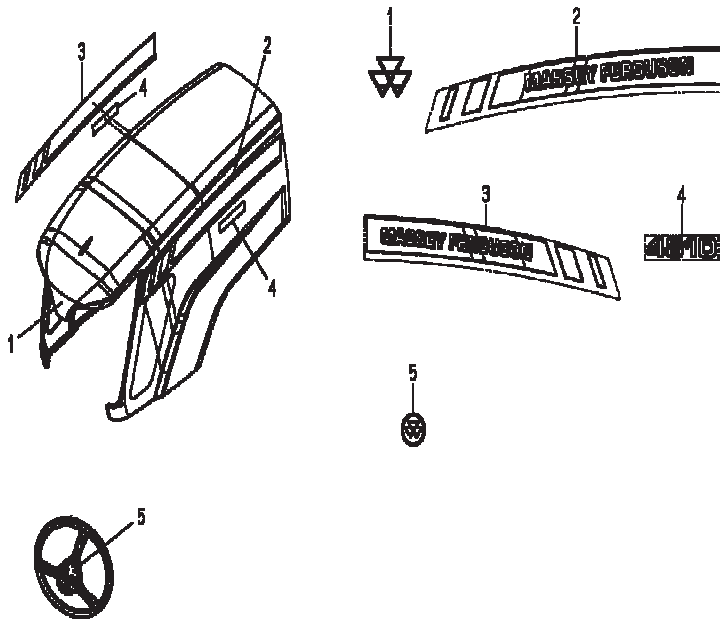

CLICK HERE TO **DOWNLOAD** THE COMPLETE MANUAL

- Thank you very much for reading the preview of the manual.
- You can download the complete manual from: www.heydownloads.com by clicking the link below



- Please note: If there is no response to CLICKING the link, please download this PDF first and then click on it.

CLICK HERE TO **DOWNLOAD** THE COMPLETE MANUAL