

DHW Draper Header REPAIR TIME SCHEDULE

Form Number 79034451 B Rev.

Contents

Section	Description
1	Drives
2	Electrical
3	Sickle
4	Draper
5	Frame and Shields
6	Hydraulics
7	Decals and Kits

CLICK HERE TO **DOWNLOAD** THE COMPLETE MANUAL

- Thank you very much for reading the preview of the manual.
- You can download the complete manual from: www.heydownloads.com by clicking the link below



- Please note: If there is no response to CLICKING the link, please download this PDF first and then click on it.

CLICK HERE TO **DOWNLOAD** THE COMPLETE MANUAL

5200 / DHW DRAPER HEADER
SICKLE

Item



Description

10

SICKLE ASSEMBLY (22 FOOT)
(700721821 KNIFE ASSEMBLY)

1	DR 01 05	1.5	NYLON BUSHING
2	HD 02 12	1.25	KNIFE HEAD
4	HD 02 06	0.1	END SICKLE SECTION
9	HD 02 17	0.1	SICKLE SECTION
10	HD 02 08	1.0	LEFT KNIFE ASSEMBLY
10	HD 02 17	0.1	SICKLE SECTION
11	HD 02 01	1.25	BACKING BAR
12	HD 02 11	1.25	BOTTOM JOINER
14	HD 02 09	1.0	RIGHT KNIFE ASSEMBLY
15	HD 02 07	0.1	END SICKLE SECTION
16	HD 02 02	1.25	BACKING BAR
17	HD 02 16	1.25	TOP JOINER

700721821-0

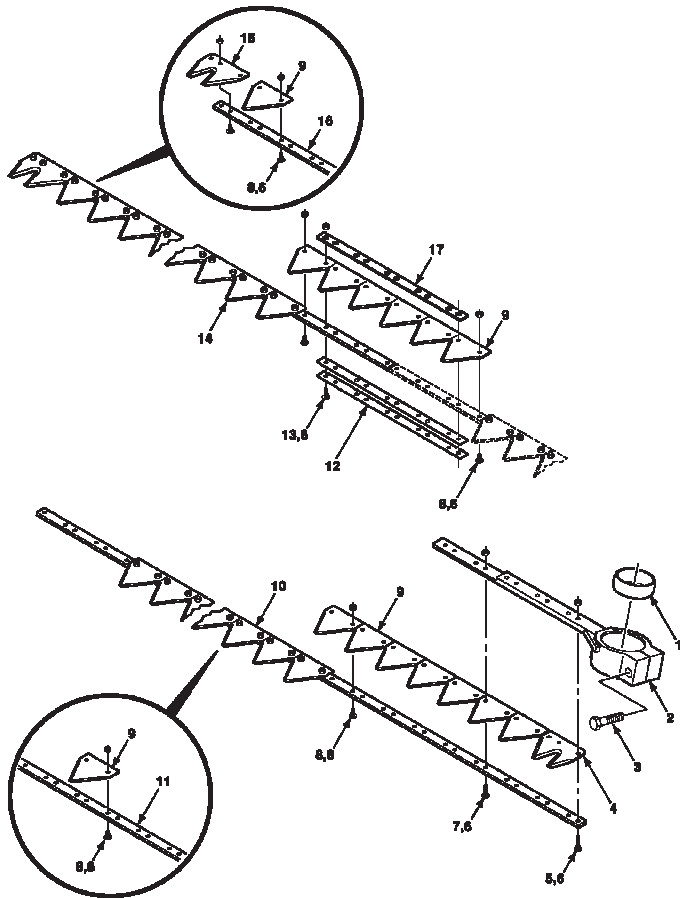

700 721 821-0

5200 / DHW DRAPER HEADER
DRAPER

ROLLER MOUNTING-RIGHT

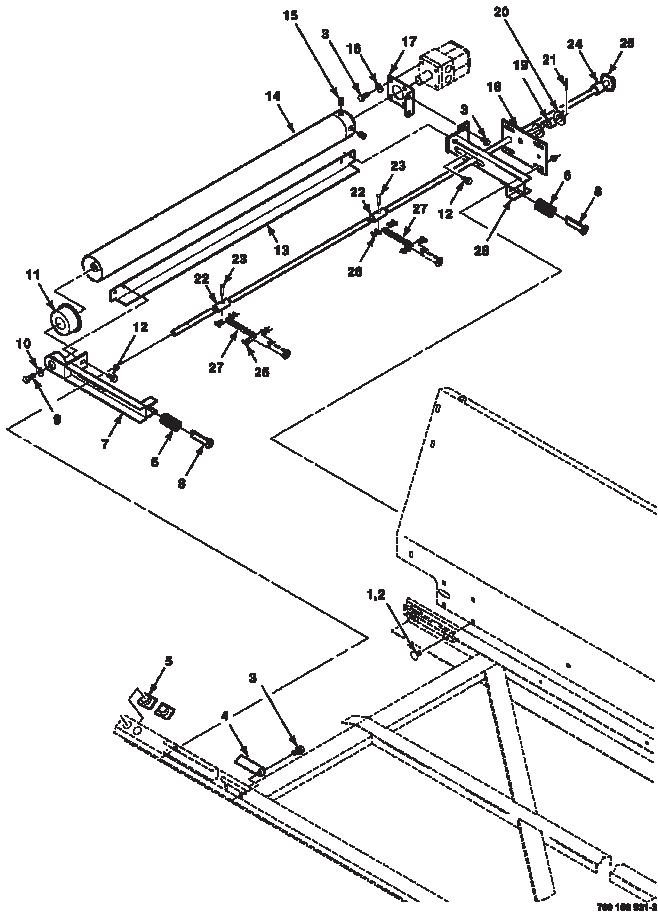

Item



Description

20

4	MF 02 17	1.0	HOLD DOWN
5	MF 03 39	0.5	PLASTIC SLIDER
6	DR 07 01	1.5	TENSIONER SPRING
7	DR 07 06	3.0	FRONT TENSIONER BRACKET
8	DR 07 04	1.0	CHAIN CONNECTOR
11	DR 01 08	2.0	ROLLER BEARING
13	DR 04 02	1.5	ROLLER BRACE
14	DR 14 03	2.0	DRIVE ROLLER
14	DR 14 01	2.0	RUBBER COATED ROLLER
17	DR 09 01	2.5	MOTOR MOUNT
18	DR 07 08	2.0	TENSIONER PLATE
19	DR 07 07	1.0	TENSIONER LATCH
22	DR 07 10	2.0	TENSIONER COLLAR
24	DR 07 11	2.0	TENSIONER SPACER
25	DR 07 13	2.0	TENSIONER ROD
26	DR 07 02	1.0	NO. 40 CONNECTOR LINK
27	DR 07 05	2.0	TENSIONER CHAIN
28	DR 07 03	3.0	REAR TENSIONER BRACKET

700152921-2

5200 / DHW DRAPER HEADER
DRAPER

Item



Description

30

DECK ASSEMBLY-RIGHT (36 FOOT)

- | | | | |
|----|----------|-----|----------------|
| 1 | MF 02 17 | 1.0 | HOLD DOWN |
| 3 | DR 04 01 | 2.0 | ROLLER PLATE |
| 8 | DR 07 12 | 2.0 | ROLLER SPACER |
| 9 | DR 01 08 | 2.0 | ROLLER BEARING |
| 10 | DR 08 05 | 2.0 | ROLLER SHAFT |
| 11 | DR 06 03 | 2.0 | IDLER TUBE |
| 15 | MF 03 39 | 0.5 | PLASTIC SLIDER |
| 16 | MF 01 09 | 3.0 | DRAPER DECK |
| 17 | MF 03 12 | 0.5 | CLAMP PLATE |
| 18 | MF 03 11 | 0.5 | SPACER |
| 20 | MF 04 08 | 2.0 | WINDBOARD |
| 23 | MF 03 09 | 0.5 | LONG RETAINER |

700156622-0

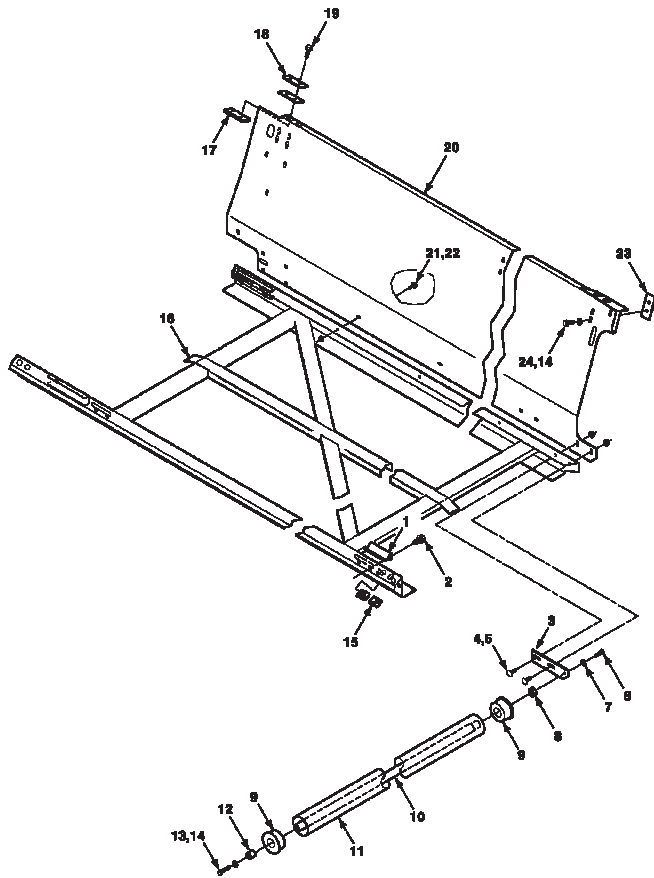

700 100 822-0

5200 / DHW DRAPER HEADER
FRAME AND SHIELDS

Item



Description

40

HYDRAULIC SHIELDS (18 FOOT)

2	SH 03 01	0.4	MOUNTING PLATE
7	SH 05 02	0.1	CLAMP
8	SH 03 03	0.4	LINE CLAMP
9	SH 06 03	0.25	TRIM
10	HY 05 03	0.1	HOSE RETAINER
11	SH 02 10	0.25	HYDRAULIC LINE SHIELD
14	SH 02 20	0.25	HYDRAULIC LINE SHIELD
15	SH 02 05	0.25	FLOW CONTROL SHIELD

[A] THE APPROPRIATE SAFETY DECALS MUST
BE ORDERED AND FITTED TO THIS PART

700156651-0

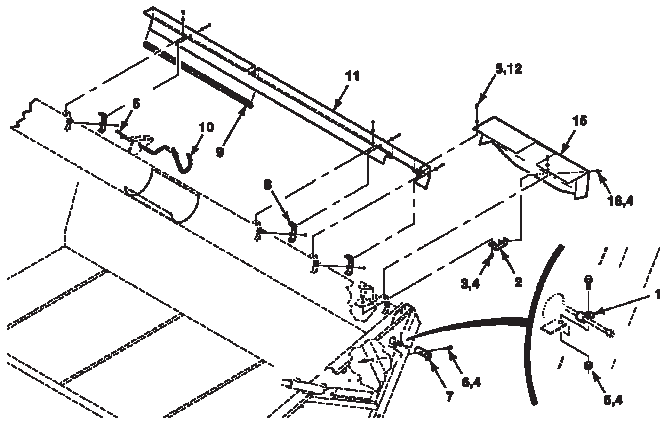
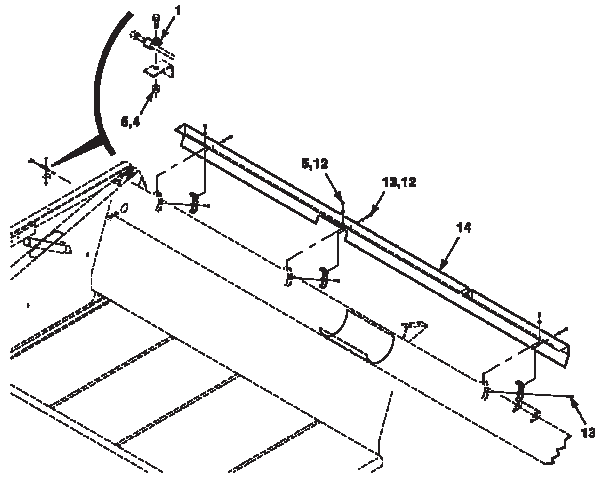

700 100 001-0

CLICK HERE TO **DOWNLOAD** THE COMPLETE MANUAL

- Thank you very much for reading the preview of the manual.
- You can download the complete manual from: www.heydownloads.com by clicking the link below



- Please note: If there is no response to CLICKING the link, please download this PDF first and then click on it.

CLICK HERE TO **DOWNLOAD** THE COMPLETE MANUAL

5200 / DHW DRAPER HEADER
HYDRAULICS

REEL AND SICKLE DRIVE-LEFT
(25 FOOT)

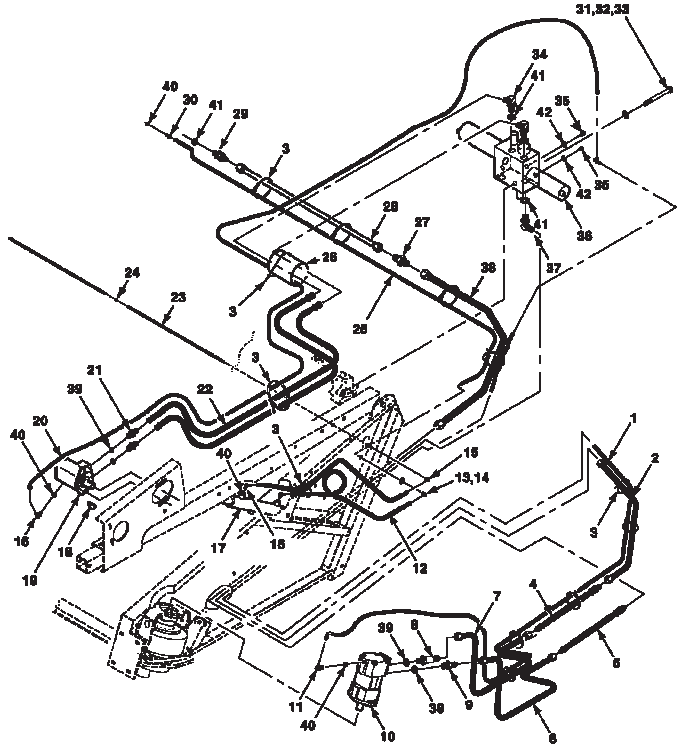

700 100 820-0

Item



Description

50

1	HY 03 17	1.0	HYDRAULIC HOSE
2	HY 11 16	1.0	HYDRAULIC LINE
4	HY 03 18	1.0	HYDRAULIC HOSE
5	HY 03 31	1.0	HYDRAULIC LINE
6	HY 11 28	1.0	HYDRAULIC LINE
7	HY 11 29	1.0	HYDRAULIC LINE
10	HY 02 01	1.5	KNIFE DRIVE MOTOR
12	HY 03 05	1.0	HYDRAULIC HOSE
17	HY 06 01	1.0	REEL LIFT MASTER CYLINDER
19	HY 02 03	1.5	REEL DRIVE MOTOR
19	HY 08 02	1.5	SEAL KIT
20	HY 03 27	1.0	HYDRAULIC HOSE
22	HY 03 24	1.0	HYDRAULIC HOSE
23	HY 11 01	1.0	HYDRAULIC LINE
25	HY 03 20	1.0	HYDRAULIC HOSE
26	SH 06 04	0.75	NYLON SLEEVE
28	HY 11 20	1.0	HYDRAULIC LINE
36	HY 04 04	1.0	FLOW CONTROL VALVE
36	HY 04 10	1.0	FLOW CONTROL VALVE
38	HY 11 27	1.0	HYDRAULIC LINE
40	HY 19 01	0.5	O-RING, ANY

700156633-0

5200 / DHW DRAPER HEADER
HYDRAULICS

Item



Description

60

CONVEYOR DRIVE HYDRAULIC-LEFT
(30 FOOT)

- | | | | |
|----|----------|-----|--------------------|
| 1 | HY 03 14 | 1.0 | HYDRAULIC HOSE |
| 2 | HY 03 25 | 1.0 | HYDRAULIC HOSE |
| 3 | HY 19 01 | 0.5 | O-RING, ANY |
| 4 | HY 02 04 | 2.0 | DRAPER DRIVE MOTOR |
| 4 | HY 08 02 | 1.5 | SEAL KIT |
| 10 | HY 11 08 | 1.0 | HYDRAULIC LINE |
| 14 | HY 11 19 | 1.0 | HYDRAULIC LINE |
| 15 | HY 03 01 | 1.0 | HYDRAULIC HOSE |
| 16 | HY 11 09 | 1.0 | HYDRAULIC LINE |
| 17 | HY 03 04 | 1.0 | HYDRAULIC HOSE |
| 19 | HY 11 21 | 1.0 | HYDRAULIC LINE |

700156654-1

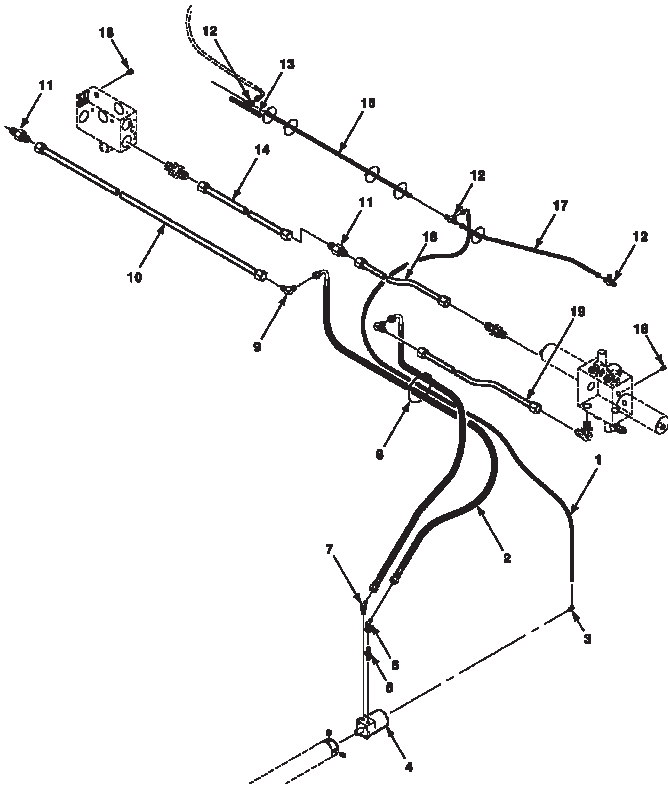

700 156 654-1

5200 / DHW DRAPER HEADER
HYDRAULICS

Item			Description	70
------	--	---	-------------	----

CONVEYOR DRIVE HYDRAULIC-LEFT
(DOUBLE SWATH)

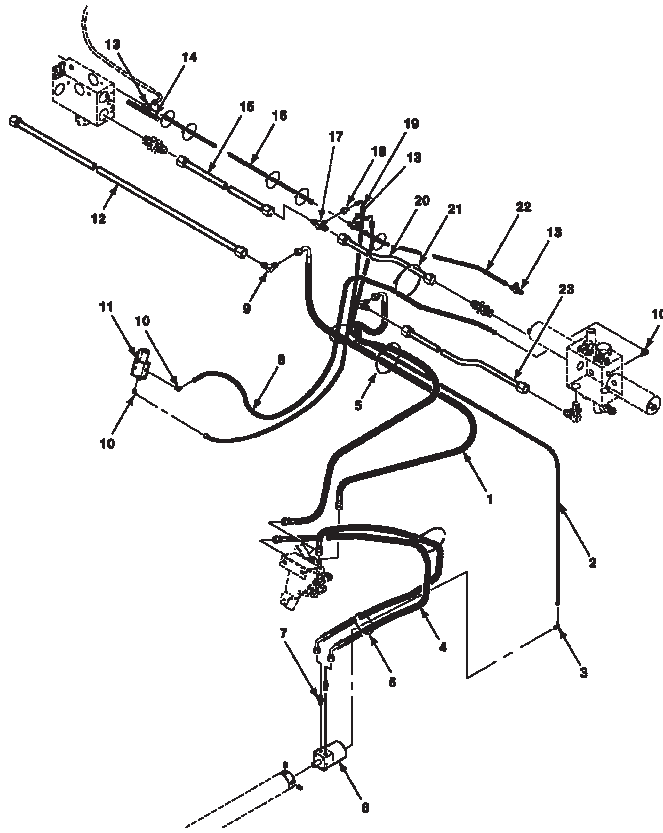

1	HY 03 25	1.0	HYDRAULIC HOSE
2	HY 03 14	1.0	HYDRAULIC HOSE
3	HY 19 01	0.5	O-RING, ANY
4	HY 03 26	1.0	HYDRAULIC HOSE
6	HY 02 04	2.0	DRAPER DRIVE MOTOR
6	HY 08 02	1.5	SEAL KIT
8	HY 03 07	1.0	HYDRAULIC HOSE
8	HY 03 06	1.0	HYDRAULIC HOSE
11	HY 04 13	1.0	VALVE ASSEMBLY
12	HY 11 08	1.0	HYDRAULIC LINE
15	HY 11 17	1.0	HYDRAULIC LINE
15	HY 11 18	1.0	HYDRAULIC LINE
15	HY 11 19	1.0	HYDRAULIC LINE
16	HY 03 28	1.0	HYDRAULIC HOSE
16	HY 03 30	1.0	HYDRAULIC HOSE
16	HY 03 01	1.0	HYDRAULIC HOSE
19	HY 03 35	1.0	HYDRAULIC HOSE
20	HY 11 09	1.0	HYDRAULIC LINE
22	HY 03 04	1.0	HYDRAULIC HOSE
23	HY 11 21	1.0	HYDRAULIC LINE

700156659-1

700 156 659-1

5200 / DHW DRAPER HEADER
DECALS AND KITS

Item			Description	80
------	--	---	-------------	----

PICKUP REEL KIT-22 FOOT (UNIVERSAL)
(71375020 PICKUP REEL KIT)

5	HD 03 07	0.25	INNER PLATE
6	HD 05 08	0.75	BAT ARM
7	HD 05 09	0.5	BAT ARM BRACE
8	HD 04 05	1.0	BEARING
9	HD 03 05	0.5	TIP PLATE
13	HD 05 31	4.0	22 FOOT REEL BAT
14	HD 05 12	0.1	PLASTIC TINE
15	HD 04 06	0.5	BEARING HOLDER
20	HD 06 06	0.5	END SHIELD
21	HD 03 08	0.1	WIRE TINE
23	HD 06 05	0.5	END SHIELD

[A] RIGHT SIDE ONLY [B] LEFT SIDE ONLY		
700904451-1		

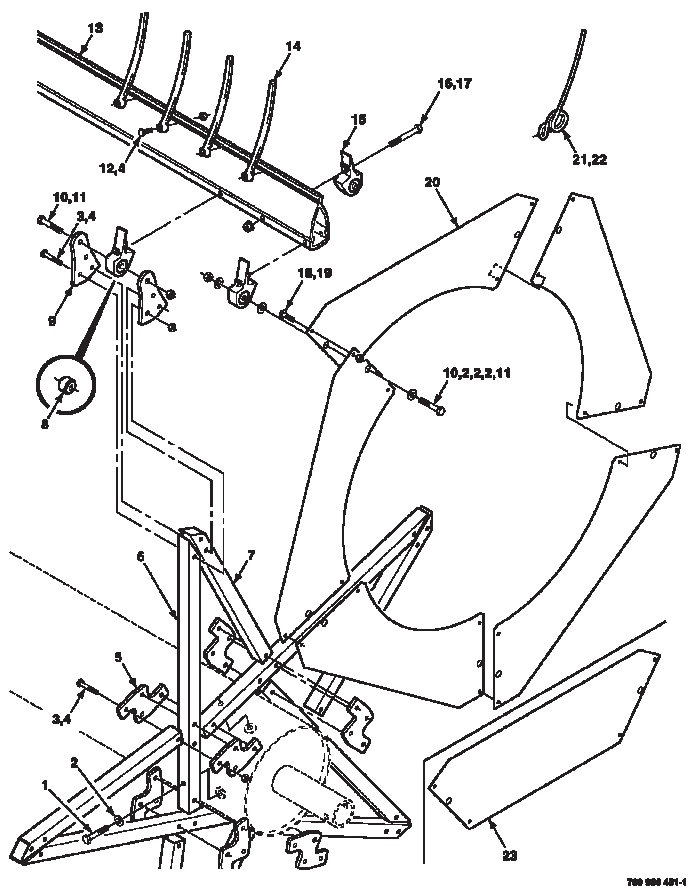

5200 / DHW DRAPER HEADER
DECALS AND KITS

Item



Description

90

PICKUP REEL KIT-22 FOOT (HARTCARTER)
(71401111 PICKUP REEL KIT)

1	DR 08 02	2.5	DRIVING SHAFT
5	HD 04 01	0.1	BEARING STRAP
6	HD 04 02	0.1	HALF BEARING
7	HD 05 18	7.0	CENTER SHAFT
8	HD 05 02	0.5	REEL ARM
9	HD 05 03	0.5	ANCHOR PLATE
10	DR 08 01	2.0	DRIVEN SHAFT
11	SH 06 02	0.5	END SHIELD

700951965-1

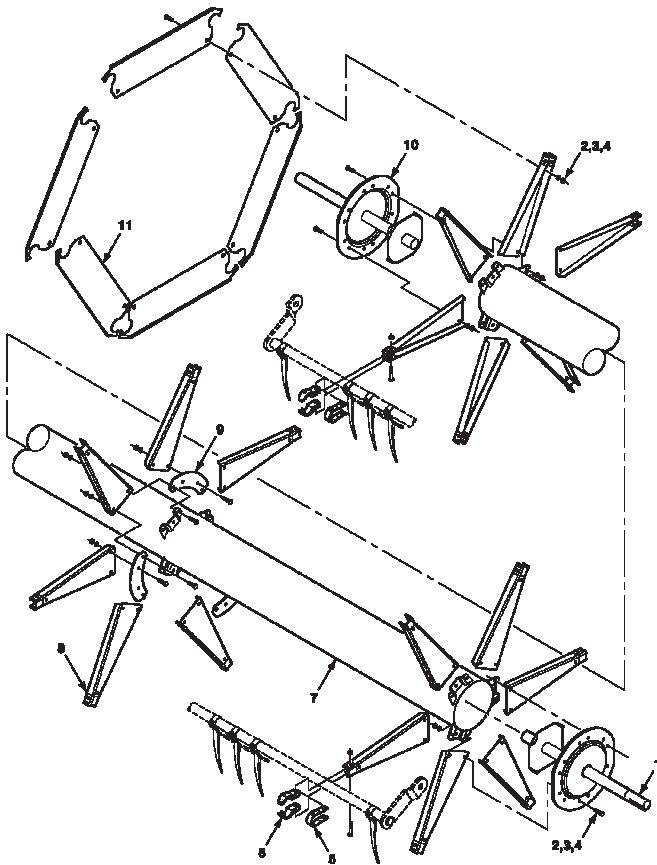

700 001 000-1

**5200 / DHW DRAPER HEADER
DECALS AND KITS**

Item



Description

100

GAUGE WHEEL KIT (FIXED)
(71393027 GAUGE WHEEL KIT)
(LEFT SIDE SHOWN, RIGHT SIDE OPPOSITE)

2	WT 01 01	0.5	RIM
3	PD 05 05	0.5	DUST CAP
6	PD 04 02	1.0	CONE BEARING
8	WT 02 01	0.5	VALVE STEM
9	PD 02 05	1.0	LEFT SUPPORT
9	PD 02 06	1.0	RIGHT SUPPORT
10	PD 05 06	1.5	SEAL
11	PD 05 07	1.5	WHEEL HUB
13	PD 04 05	1.0	BEARING CUP
14	PD 05 02	0.25	JACK LEVER

700904481-0

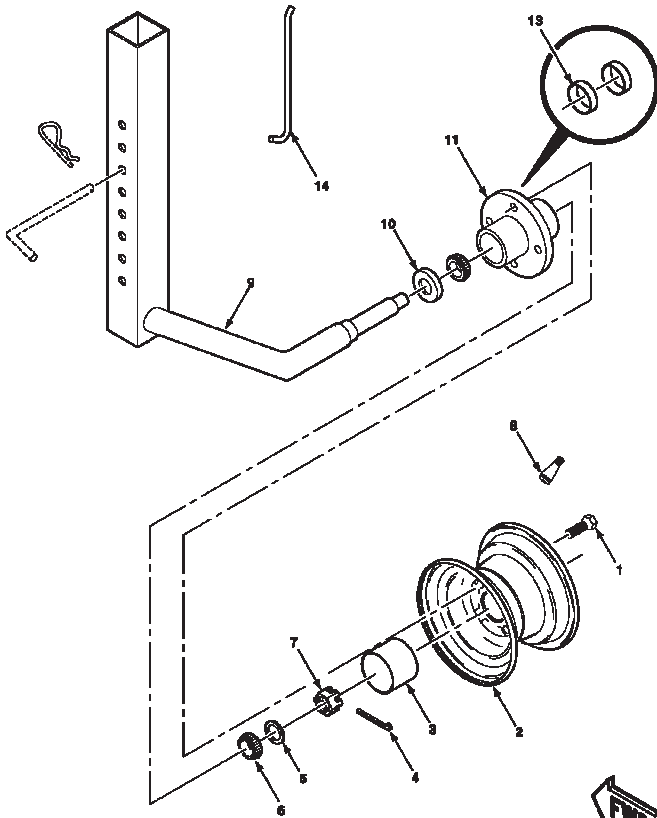

700 900 4481-0

CLICK HERE TO **DOWNLOAD** THE COMPLETE MANUAL

- Thank you very much for reading the preview of the manual.
- You can download the complete manual from: www.heydownloads.com by clicking the link below



- Please note: If there is no response to CLICKING the link, please download this PDF first and then click on it.

CLICK HERE TO **DOWNLOAD** THE COMPLETE MANUAL