

# 644H and 644H MH Loader Repair

## TECHNICAL MANUAL 644H and 644H MH Loader Repair TM1638

TM1638 15JAN04 (ENGLISH)

For complete service information also see:

644H and 644H MH Loader Operation and Test .....	TM1637
8.1 L Engine Repair .....	CTM86
8.1 L Engine Operation and Diagnostics ...	CTM134
Alternators and Starting Motors .....	CTM77
Electronic Fuel Injection Systems .....	CTM68

**Worldwide Construction  
And Forestry Division**  
LITHO IN U.S.A.

CLICK HERE TO **DOWNLOAD** THE COMPLETE MANUAL

- Thank you very much for reading the preview of the manual.
- You can download the complete manual from: [www.heydownloads.com](http://www.heydownloads.com) by clicking the link below



- Please note: If there is no response to CLICKING the link, please download this PDF first and then click on it.

CLICK HERE TO **DOWNLOAD** THE COMPLETE MANUAL

4WD Loader Safety Features

# JOHN DEERE 4WD LOADER SAFETY FEATURES

Please remember, the operator is the key to preventing accidents.

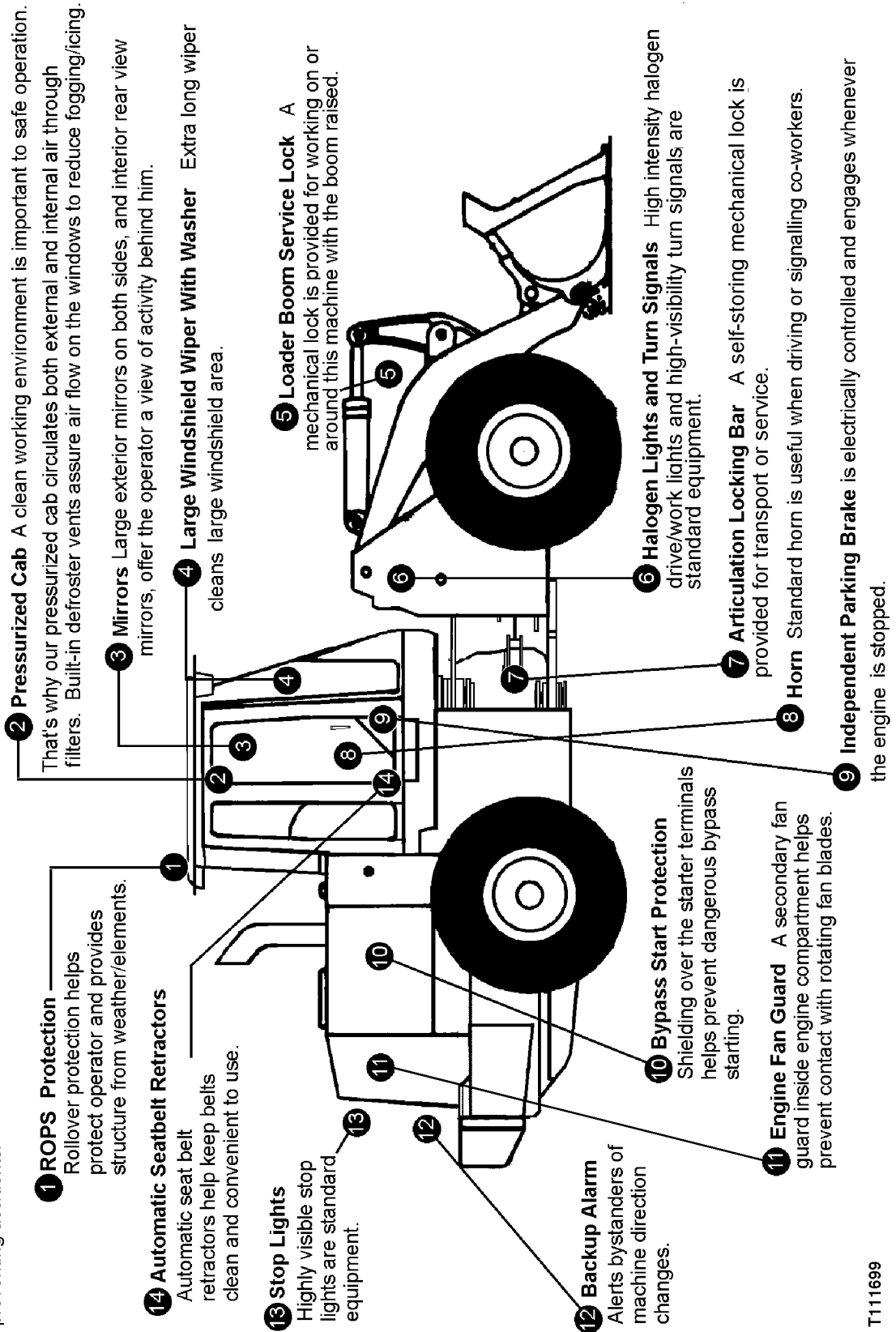

T111699

T111699 -19-04NOV98

TX,05\_JC2303 -19-09NOV98-1/1

### Keep Riders Off Machine

Only allow the operator on the machine. Keep riders off.

Riders on machine are subject to injury such as being struck by foreign objects and being thrown off of the machine. Riders also obstruct the operator's view resulting in the machine being operated in an unsafe manner.

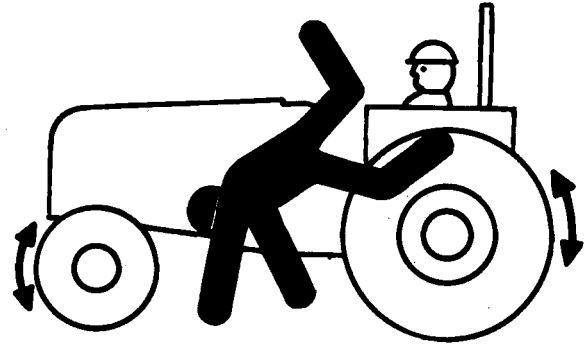

DX,RIDER -19-03MAR93-1/1

TS290 -JUN-23AUG88

### Handle Fuel Safely—Avoid Fires

Handle fuel with care: it is highly flammable. Do not refuel the machine while smoking or when near open flame or sparks.

Always stop engine before refueling machine. Fill fuel tank outdoors.

Prevent fires by keeping machine clean of accumulated trash, grease, and debris. Always clean up spilled fuel.



DX,FIRE1 -19-03MAR93-1/1

TS202 -JUN-23AUG88

### Prepare for Emergencies

Be prepared if a fire starts.

Keep a first aid kit and fire extinguisher handy.

Keep emergency numbers for doctors, ambulance service, hospital, and fire department near your telephone.

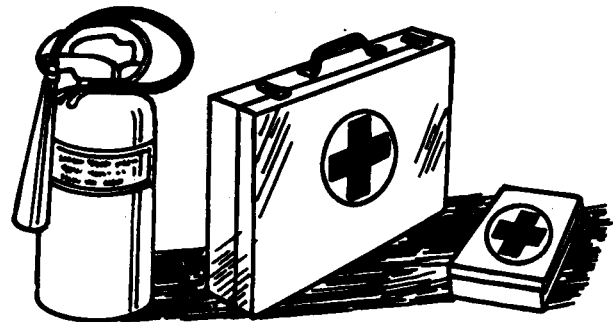

DX,FIRE2 -19-03MAR93-1/1

TS291 -JUN-23AUG88

# Section 01 Wheels

01

## Contents

### Page

#### Group 0110—Powered Wheels And Fasteners

##### Wheel

Remove and Install . . . . .01-0110-1

##### Tire

Remove . . . . .01-0110-2

Install . . . . .01-0110-4



**CAUTION:** The approximate weight of axle and differential is 885 kg (1950 lb).

**Specification**

Axle and Differential—Weight ..... 885 kg (1950 lb) approximate

12. Install low-lift jack (B) under axle and differential.
13. Remove nuts (A) to remove cap screws. Lower axle and differential.
14. Repair or replace axle or differential. (See procedure in this group.)
15. Clean mounting surface on axle housings and loader frame.
16. Install axle and differential.

Install a washer under head of cap screws and a washer under the nuts. Hold the cap screws and tighten the nuts.

**Specification**

Frame-to-Axle Housing Cap  
Screw and Nut—Torque..... 675 N•m (500 lb-ft)

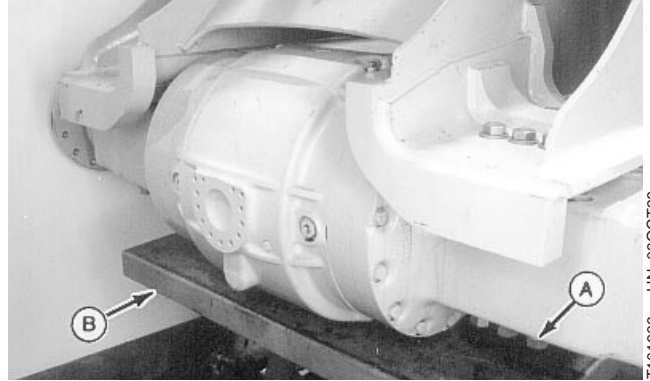

A—Nut  
B—Low-Lift Jack

T101609 -UN-03OCT96

02  
0200  
3

Continued on next page

CED.OUOE002,1492 -19-14MAY98-4/6

Removal And Installation

- |                            |                           |                              |                                 |
|----------------------------|---------------------------|------------------------------|---------------------------------|
| 1—Special Jam Nut (2 used) | 8—Thrust Bearing (6 used) | 14—Cap Screw (6 used)        | 20—Elbow Fitting                |
| 2—Fitting (2 used)         | 9—Thrust Plate            | 15—Cap Screw (6 used)        | 21—Lubrication Fitting (2 used) |
| 3—Pipe Plug                | 10—Washer (4 used)        | 16—Seal (2 used)             | 22—Washer (10 used)             |
| 4—Hydraulic Hose           | 11—Cap Screw (4 used)     | 17—Cap Screw (4 used)        | 23—Bushing (2 used)             |
| 5—Elbow Fitting (3 used)   | 12—O-Ring                 | 18—Front Oscillating Support | 24—Lubrication Fitting          |
| 6—Rear Oscillating Support | 13—Cover                  | 19—Hydraulic Hose            |                                 |
| 7—Bushing (2 used)         |                           |                              |                                 |

*NOTE: Axle oscillation support assembly does not contain any shims for setting end play. If excessive end play is incurred due to wear, end play should be no greater than 0.762 mm (0.03 in). This can be checked with dial indicator measuring between front support and the differential housing. If greater than 0.762 mm (0.03 in.) thrust bearings should be replaced. Also check thrust plate (between both thrust bearings) for wear on front side. Disk should not have more than 0.254 mm (0.01 in.) wear step on face that contacts front thrust bearings. If out of specification, replace thrust plate and thrust bearings.*

**Specification**

Axle-to-Oscillation Support—  
End Play ..... 0.762 mm (0.03 in) maximum

1. Remove rear axle and differential assembly. See this group.
2. Remove front oscillating support.
3. Remove cap screws (14 and 11) from pivot cover (13) and thrust plate (9) in rear oscillating support.
4. Remove rear oscillating support.
5. Repair and replace parts as necessary.
6. Inspect thrust bearings (8) and bushings (7) for wear.
7. Lube thrust bearings and bushings with grease and pack cavity of cover (13).

02  
0200  
13

Continued on next page

CED,OUOE002,1495 -19-14MAY98-2/3

*Axle Shaft, Bearings, Reduction Gears*

Driver Disk (5-1/4 in.) . . . . . JDG986

To install differential bearing cup.

CED,OUOE003,1003 -19-25JUN98-8/14

Driver Disk (6-1/2 in.) . . . . . JDG1154

Install ring gear cover bearing cup

CED,OUOE003,1003 -19-25JUN98-9/14

02  
0250  
5

Driver Disk (2-3/4 in.)

To remove differential lock piston.

CED,OUOE003,1003 -19-25JUN98-10/14

Driver Disk (8-3/4 in.) . . . . . JDG1153

To install differential housing bearing cup.

CED,OUOE003,1003 -19-25JUN98-11/14

Driver Disk (3-1/2 in.)

Remove oil dam.

CED,OUOE003,1003 -19-25JUN98-12/14

Driver Disk (4-1/2 in.)

Install shield into counterbore.

CED,OUOE003,1003 -19-25JUN98-13/14

Driver Disk (5-1/2 in.) . . . . . JDG135

To remove snap ring.

CED,OUOE003,1003 -19-25JUN98-14/14

Remove sun pinion shaft (A) and brake pack (B).

A—Sun Pinion Shaft  
B—Brake Pack

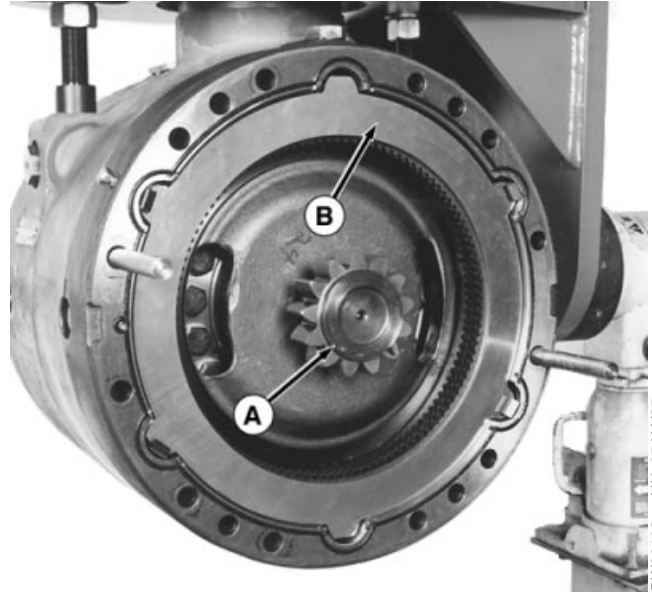

RW36102 -UN-07JAN97

02  
0250  
15

TX,02,111708 -19-15MAY98-6/6

### Install Final Drive Assembly

Install O-ring packing (A) on ring gear.

A—O-Ring Packing on Ring Gear



RW36103 -UN-02JAN97

Continued on next page

TX,02,111709 -19-15MAY98-1/3

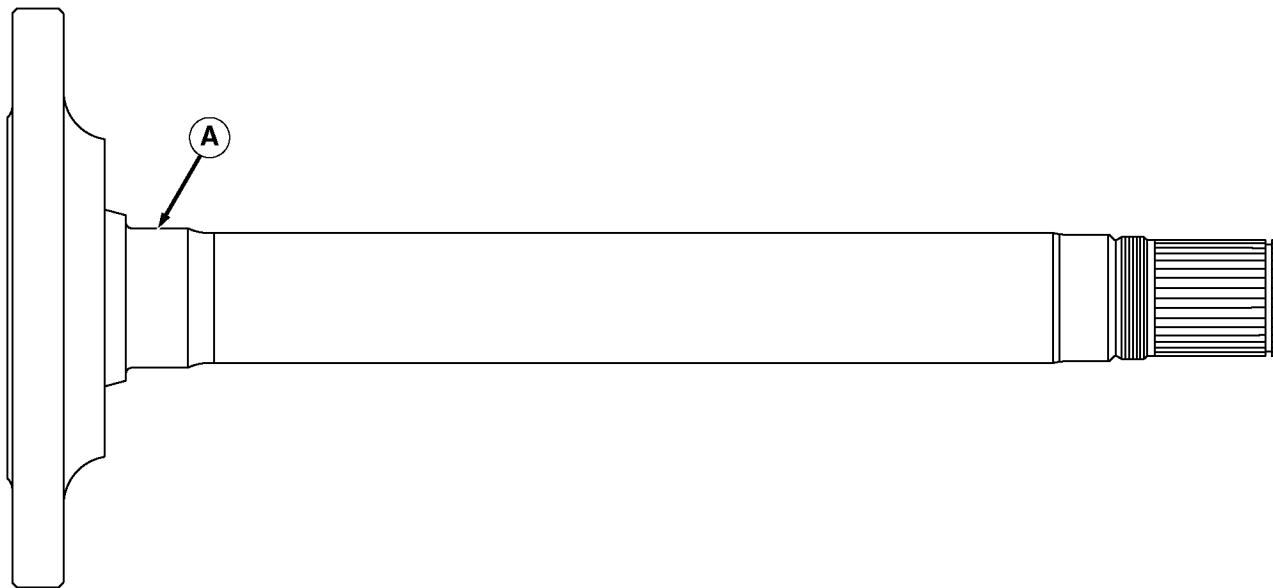

02  
0250  
25

RW56111 -UN-02JAN97

**A—Axle Shaft Outer Bearing  
Surface Diameter**

Inspect axle shaft outer bearing adjoining surface.

Replace parts as required.

**Specification**

Axle Shaft Outer Bearing	
Surface—Diameter .....	114.357—114.383 mm (4.502—4.503 in.) new

Inspect and clean seal bore in axle shaft. Bore must be clean and free of foreign material.

CED,OUOE002,1500 -19-15MAY98-4/4

3. Install differential. See Install Differential in this group.

Rotate the differential housing several times in both directions to seat and roll-in the bearings.



RW36242 -UN-18FEB97

02  
0250  
35

CED,OUOE002,1502 -19-15MAY98-2/10

4. Install JDG1156 Stand-Off Gauge Blocks (A) and JDG1126 Housing Preload Measuring Bar (B) on differential case cover surface (C).

5. Record 142.88 mm (5.625 in.) nominal dimension from top of bar to differential case cover surface.

*NOTE: The nominal dimension of preload measuring bar is 127 mm (5.000 in.). The nominal dimension of the gauge block is 15.88 mm (0.625 in.).*

6. Measure and record distance from top of bearing cone surface (D) to top of bar using a depth micrometer (E). Measure in four different locations around the cone surface and average the readings.

7. Subtract the dimension from Step 5 from the average dimension from Step 6. The result is bearing cone surface-to-cover surface dimension.

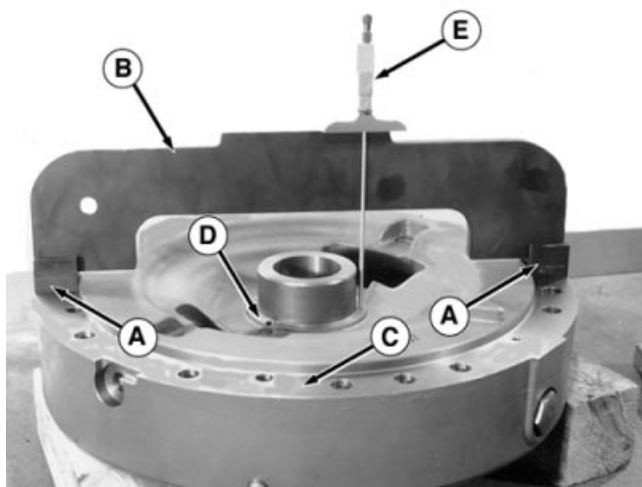

RW36508 -UN-19JUN97

- A—JDG1156 Stand-Off Gauge Block
- B—JDG1126 Housing Preload Measuring Bar
- C—Differential Case Cover-to-Case Surface
- D—Bearing Cone Surface
- E—Depth Micrometer

Continued on next page

CED,OUOE002,1502 -19-15MAY98-3/10

Remove differential lock bevel gear (A).

A—Differential Lock Bevel Gear

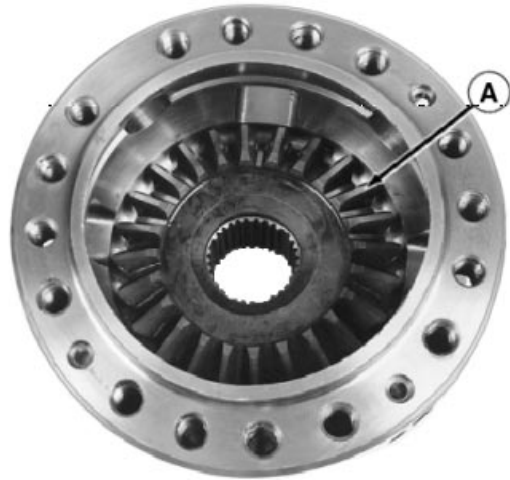

RW36238 -UN-18FEB97

02  
0250  
45

CED,OUOE002,1516 -19-19MAY98-8/30

Remove thrust washer (A).

A—Thrust Washer

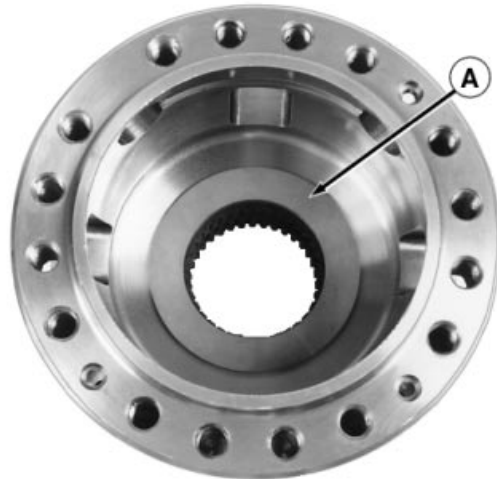

RW36239 -UN-18FEB97

CED,OUOE002,1516 -19-19MAY98-9/30

Remove needle roller bearing (A) and needle bearing thrust washer (B).

A—Needle Roller Bearing  
B—Thrust Washer

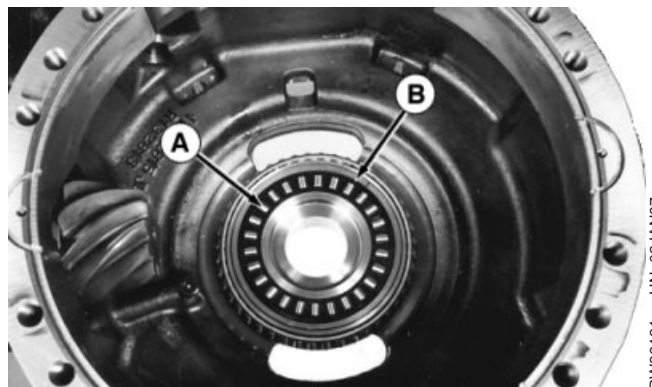

RW36121 -UN-02JAN97

Continued on next page

CED,OUOE002,1516 -19-19MAY98-10/30

## Disassemble, Inspect, And Assemble Standard Differential

Remove differential. See Remove Differential in this group.

CED.OUOE002,1517 -19-19MAY98-1/13

02  
0250  
55

Inspect bearing cup (A) in case.

*NOTE: The differential bearing preload shims are under the cup. DO NOT lose or misplace.*

Remove cup and shims if necessary.

Install shims in place and install new cup tight against shims using correct driver disk.

A—Bearing Cup

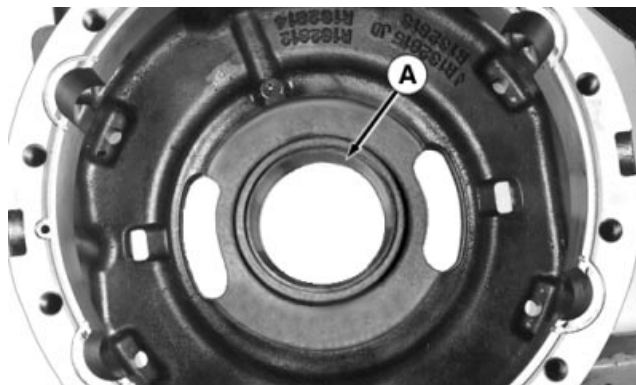

RW36159 -JUN-08JAN97

CED.OUOE002,1517 -19-19MAY98-2/13

Remove cover-to-housing cap screws (A).

A—Cap Screw (16 used)



RW36233 -JUN-18FEB97

Continued on next page

CED.OUOE002,1517 -19-19MAY98-3/13

Inspect housing cover and bearing cup (A).

Remove cup and replace as necessary.

Install bearing cup tight against bottom surface using correct driver disk.

A—Bearing Cup



RW36259 -JUN-24FEB97

02  
0250  
65

CED,OUOE002,1519 -19-19MAY98-8/20

*NOTE: Tabbed thrust washer may come out with the cover.*

Remove tabbed thrust washer (A) and thrust spacer (B).

Inspect the thrust spacer (B) and replace as necessary.

Inspect the ring gear (C) and replace as necessary.

**IMPORTANT: Differential ring gear and pinion shaft are serviced as a matched set. Be sure number stamped on ring gear and pinion end of shaft are the same. Make all input shaft and differential adjustments when replacing ring gear and pinion shaft.**

Remove ring gear from housing by striking the underside of the ring gear with a soft hammer.

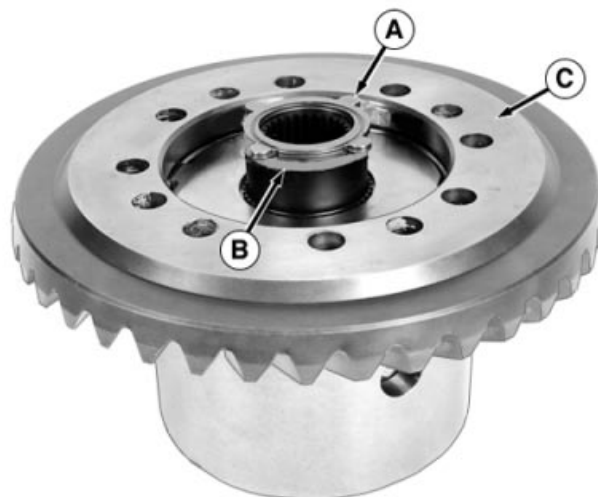

A—Thrust Washer  
B—Thrust Spacer  
C—Ring Gear

RW36246 -JUN-19FEB97

Continued on next page

CED,OUOE002,1519 -19-19MAY98-9/20

Install thrust washer (B) and tabbed thrust washer (A).

Install housing cover and remove the guide pins.

- A—Thrust Washer
- B—Thrust Spacer



02  
0250  
75  
RW36273 -JUN-27FEB97

CED,OUOE002,1521 -19-19MAY98-2/3

**NOTE:** The housing cover cap screws have pre-applied **LOCTITE®** on the threads. Use only the specified cap screws.

Install and tighten cap screws (A).

Tighten cover-to-ring gear-to-housing cap screws.

**Specification**

Cover-to-Ring Gear-to-Housing	
Cap Screw—Torque .....	375 N•m (277 lb-ft)

Install differential. See Install Differential in Group 30.

- A—Cap Screw (16 used)



RW36233 -JUN-18FEB97

*LOCTITE is a trademark of Loctite Corp.*

CED,OUOE002,1521 -19-19MAY98-3/3

- Remove nut and yoke. Press shaft (C) out of housing using JDG1093 Input Shaft Removal Tool (A) and a bottle jack (B).

A—JDG1093 Input Shaft Removal Tool  
 B—Bottle Jack  
 C—Shaft

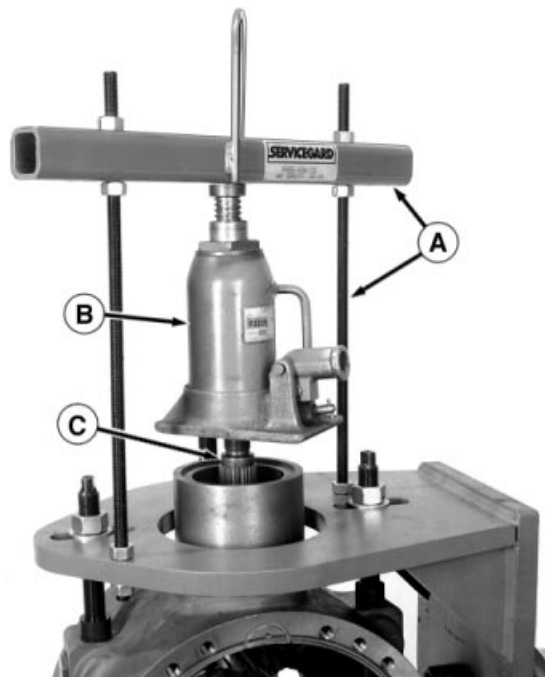

RW36212 -UN-10JAN97

02  
0250  
85

TX,02,111669 -19-30JUN98-3/6

- Install bevel pinion shaft (A) through case.
- Hold the shaft in position using a bottle jack under the pinion shaft.

**IMPORTANT:** Install spacer (C) first with ID chamfer facing away from shims and then shims.

*NOTE:* Newer spacers (C) have a chamfer on both sides. Older spacers have a chamfer on one side only.

*Suggested shim pack of 1.50 mm (0.059 in.) plus spacer. The suggested shim pack is OVERSIZE to provide enough end play so that a measurement may be taken.*

- Install 1.50 mm (0.059 in.) shim pack (B) with spacer against spiral bevel shaft shoulder to provide end play.
- Install outer bearing cone onto the shaft.

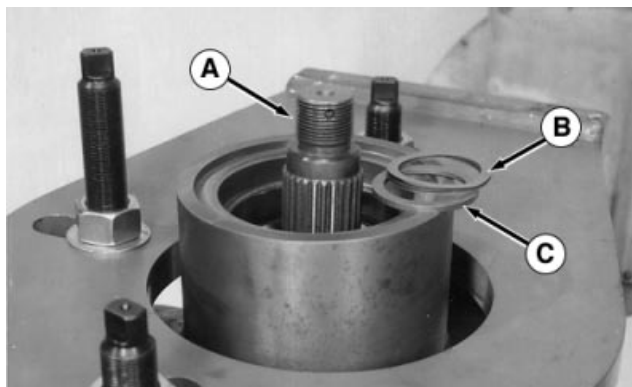

A—Bevel Pinion Shaft  
 B—Shim Pack  
 C—Spacer

RW36213 -UN-07JAN97

Continued on next page

TX,02,111669 -19-30JUN98-4/6

Remove parts (A—C) from housing (D).

Inspect parts and replace as necessary.

Assemble in reverse order.

- A—Needle Roller Bearing
- B—Shift Collar
- C—Needle Roller Bearing Thrust Washer
- D—Collar Assembly Housing
- E—Collar Assembly Spring Retainer Plate

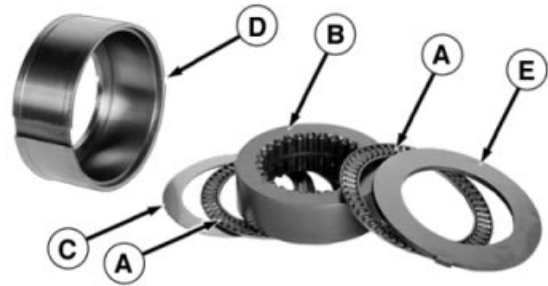

RW36299 -UN-17MAR97

02  
0250  
95

CED,OUOE002,1526 -19-19MAY98-10/25

Remove collar engagement springs (A) from housing.

Inspect springs.

**Specification**

Collar Engagement Spring—Free  
 Length ..... 73 mm (2.874 in.) approximate  
 Test Length..... 44.45 mm at 352—431 N  
 (1.750 in. at 78—96 lb-force)

- A—Collar Engagement Spring (4 used)

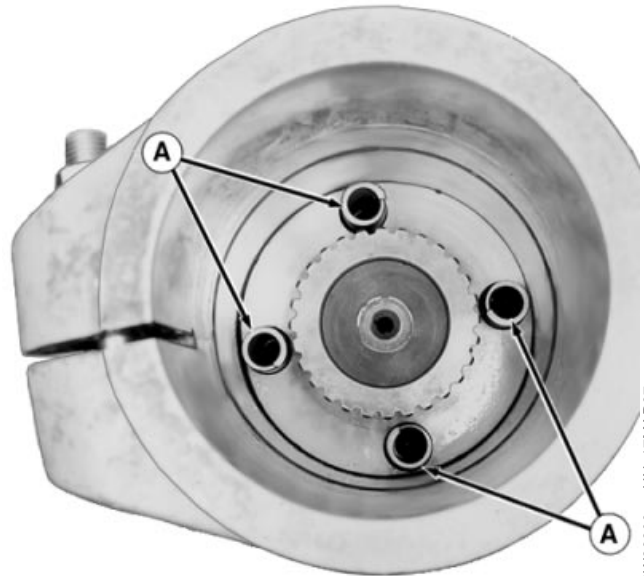

RW36300 -UN-17MAR97

Continued on next page

CED,OUOE002,1526 -19-19MAY98-11/25

# Section 03 Transmission

## Contents

	Page		Page
<b>Group 0300—Removal And Installation</b>			
Transmission		Converter Relief Valve	
Remove and Install . . . . .	03-0300-1	Remove, Disassemble and Install . . . . .	03-0360-19
		Replace Oil Pipes And Tubes . . . . .	03-0360-21
<b>Group 0350—Gears, Shafts, Bearings And Power Shift Clutch</b>			
Torque Converter		<b>Group 0399—Dealer Fabricated Tools</b>	
Remove (Engine Removed). . . . .	03-0350-1	DFT1149 Pre-Load Clutch Pack Compression	
Install (Engine Removed). . . . .	03-0350-3	Ring Tool. . . . .	03-0399-1
Torque Converter and Housing		DFT1063 Lifting Bracket . . . . .	03-0399-2
Remove . . . . .	03-0350-6	DFT1158 Torque Converter Adapter	
Install. . . . .	03-0350-8	Plate . . . . .	03-0399-3
Clutches, Input and Output Shafts			
Remove . . . . .	03-0350-11		
Clutches, Output and Input Shafts			
Install. . . . .	03-0350-18		
Clutch Pack KV and KR			
Disassemble . . . . .	03-0350-26		
Assemble. . . . .	03-0350-29		
Clutch Pack K1, K2 and K3			
Disassemble . . . . .	03-0350-36		
Assemble. . . . .	03-0350-39		
Clutch Pack K4			
Disassemble . . . . .	03-0350-48		
Assemble. . . . .	03-0350-49		
Input Shaft			
Dissassemble . . . . .	03-0350-56		
Assemble. . . . .	03-0350-57		
<b>Group 0360—Hydraulic System</b>			
Transmission Pump			
Remove . . . . .	03-0360-1		
Converter Minimum Pressure Regulator			
Valve			
Remove and Install . . . . .	03-0360-3		
Transmission Pump			
Install. . . . .	03-0360-4		
Hydraulic Control Valve			
Remove . . . . .	03-0360-6		
Install. . . . .	03-0360-7		
Cross Section View . . . . .	03-0360-9		
Transmission Control Valve			
Disassemble . . . . .	03-0360-10		
Assemble. . . . .	03-0360-13		

03

- Remove hex head screws and separate input shaft from drive plate.

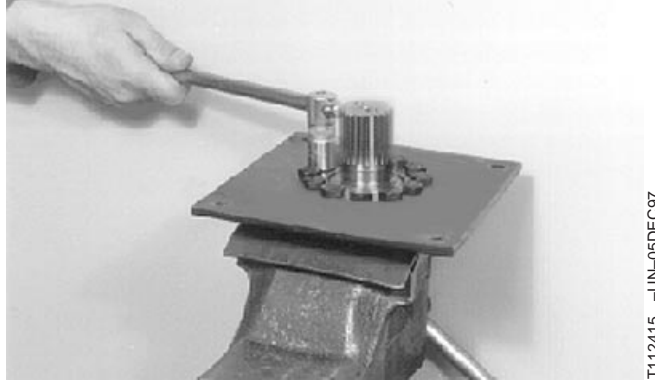

CED,OUOE002,1541 -19-20MAY98-8/9

T112415 -UN-05DEC97

- Remove speed sensor (A) from converter housing.
- Remove cap screws (B) and remove converter housing, if necessary.

A—Speed Sensor  
B—Cap Screw (17 used)

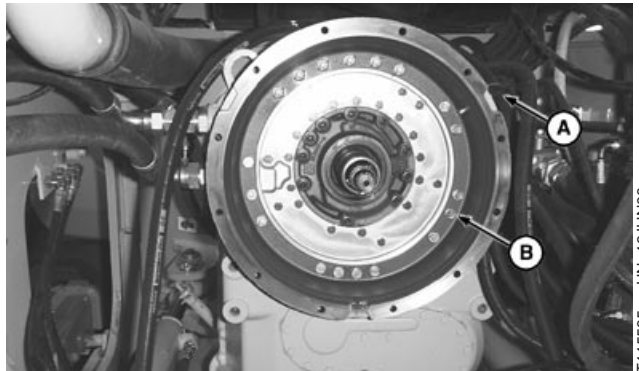

CED,OUOE002,1541 -19-20MAY98-9/9

T115535 -UN-12JUN98

03  
0350  
3

### Install Torque Converter (Engine Removed)

- Fasten converter housing using cap screws (B), if removed.

A—Speed Sensor  
B—Cap Screw (17 used)

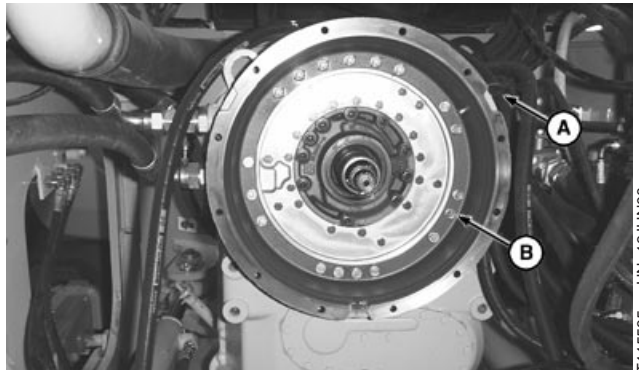

CED,OUOE002,1542 -19-27JUL98-1/8

T115535 -UN-12JUN98

- Fasten input shaft to plate with hex head screws and tighten.

#### Specification

Input Shaft-to-Drive Plate  
(M12/10.9) Hex Head Screw—  
Torque ..... 115 N•m (85 lb-ft)

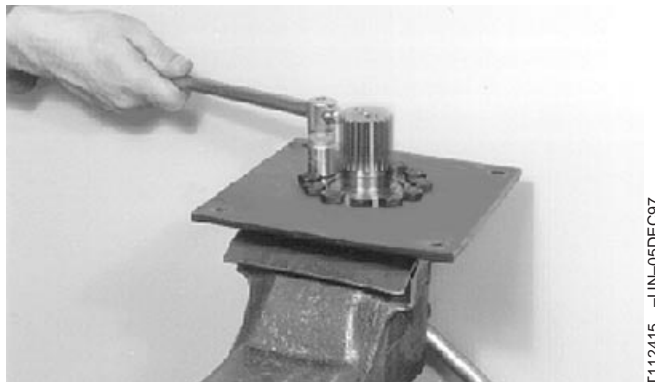

Continued on next page

CED,OUOE002,1542 -19-27JUL98-2/8

T112415 -UN-05DEC97

Figure shows the proper position of the single clutches as well as of the input and output.

- KV—Low Range Forward Clutch
- KR—Reverse Clutch
- K1—First Speed Clutch
- K2—Second Speed Clutch
- K3—Third Speed Clutch
- K4—High Range Forward Clutch
- AN—Input
- AB—Output

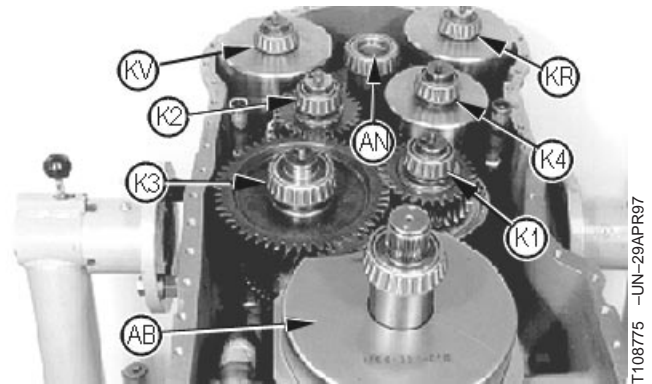

T108775 -UN-29APR97

03  
0350  
13

TX,0350,ME280 -19-20MAY98-6/19

**NOTE:** For the removal of clutches, the output shaft must be removed first.

Loosen socket head screws from covers and remove output shaft with covers.

**IMPORTANT:** Remove sealing rings from clutch pack shafts (cover side only) before installing cover. Sealing rings may be damaged while removing and installing clutch packs later.

Place cover back on transmission until it contacts the mounting surface so clutch packs can be removed from housing for repair or inspection.



T108776 -UN-18APR97

Continued on next page

TX,0350,ME280 -19-20MAY98-7/19

Lubricate and install both O-rings into the groove of the oil pipes.



T109075 -UN-29APR97

CED,OUOE003,1009 -19-25JUN98-20/32

Apply TY16021 High Flex Form-In-Place Gasket to mounting face of cover.

*NOTE: Pay attention to the engagement of the oil pipe with the bores in the housing cover.*

Install housing cover carefully against gearbox housing until contact is obtained, using lifting device.

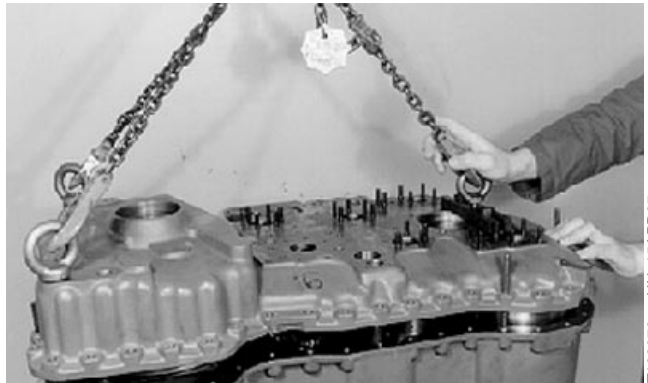

T109076 -UN-15APR97

CED,OUOE003,1009 -19-25JUN98-21/32

03  
0350  
23

Install dowel pins.

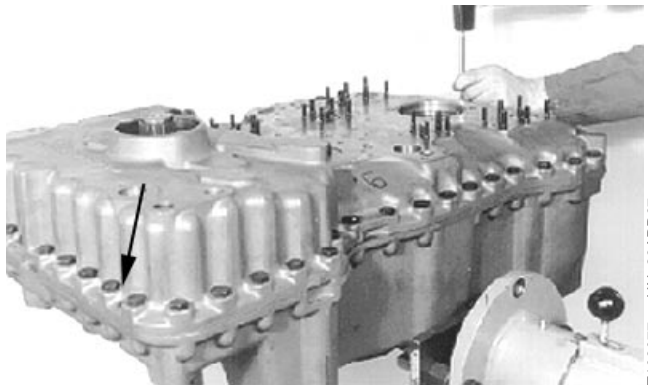

T109077 -UN-29APR97

CED,OUOE003,1009 -19-25JUN98-22/32

*NOTE: Locate hanger in same position as it was removed.*

Install housing cover using hex head screws.

**Specification**

Housing Cover Hex Head  
Screw—Torque..... 46 N•m (34 lb-ft)

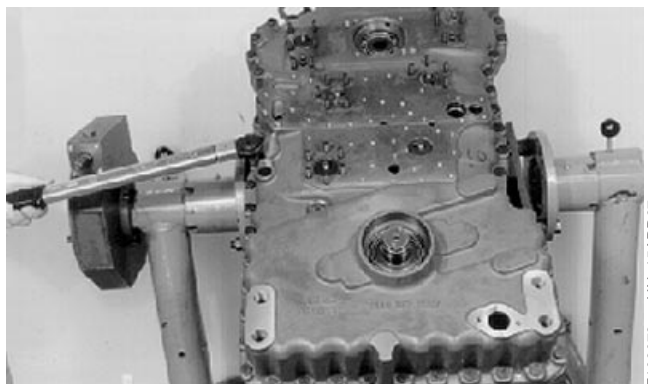

T109078 -UN-15APR97

Continued on next page

CED,OUOE003,1009 -19-25JUN98-23/32

Adjust plate clearance to specification.

**Specification**

KV and KR Clutch Pack Plate—

Clearance ..... 2.7—2.9 mm  
(0.106—0.114 in.)

*NOTE: For the adjustment of the plate clearance there are snap rings of different thickness available through parts system that can be used if proper clearance is unable to be obtained. To ensure proper measuring results, install plates temporarily without oil.*

Press end shim and measure the dimension from the end face/plate carrier to the end shim with depth gauge. Record Dimension No. 1.

Press end shim against snap ring (upward) until contact and measure with gauge. Record Dimension No. 2.

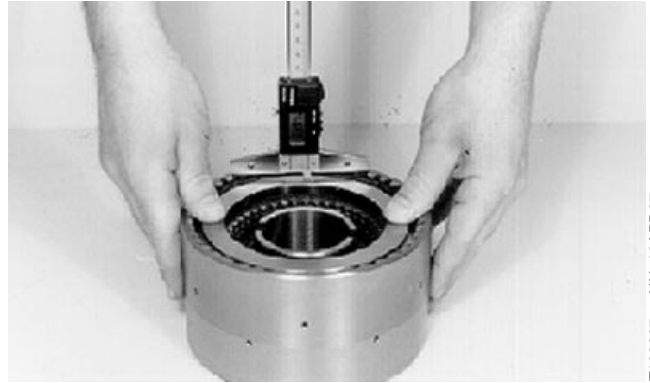

T108667 -JUN-10APR97



T108668 -JUN-10APR97

03  
0350  
33

Example for Clutch Pack Clearance Check	
Dimension No. 1	7.25 mm (0.285 in.)
Dimension No. 2	4.55 mm (0.179 in.)
Difference = Plate Clearance	2.7 mm (0.106 in.)
Specification = Pack Clearance	2.7—2.9 mm (0.106—0.114 in.)

If a clutch pack clearance is not in specification, correct by using the proper corresponding snap ring from service parts to increase or decrease clearance. Snap rings come in various sizes.

After proper clearance is obtained remove disks and plates from assembly.

Add oil to plates and disks.

Reassemble clutch pack assembly.

Continued on next page

CED,OUOE002,1545 -19-20MAY98-8/18

Press end shim against snap ring (upward) until contact and measure with gauge. Record dimension (No 2).

Example for Clutch Pack Clearance Check	
Dimension No 1	8.50 mm (0.335 in.)
Dimension No 2	6.00 mm (0.236 in.)
Difference = Plate Clearance	2.50 mm (0.079 in.)
Specification = Pack Clearance	2.4—2.6 mm (0.094—0.102 in.)

If a clutch pack clearance is not in specification, correct by using the proper corresponding snap ring from service parts to increase or decrease clearance. Snap rings come in various sizes.

After proper clearance is obtained remove disks and plates from assembly.

Add oil to plates and disks.

Reassemble clutch pack assembly.

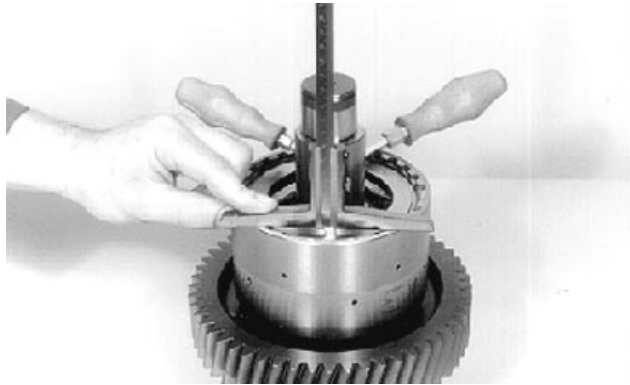

T108740 -UN-09MAY97

03  
0350  
43

Continued on next page

CED,OUOE002,1547 -19-20MAY98-11/23

Install end shim and snap ring.

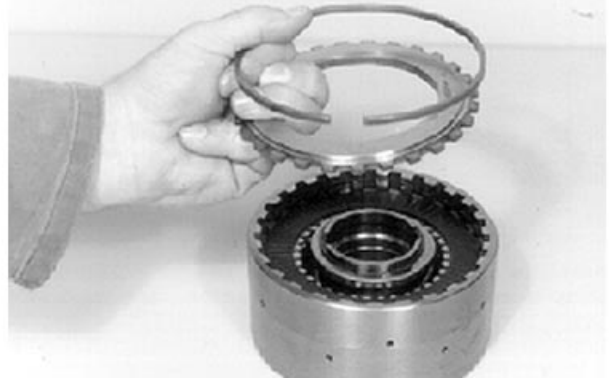

T108985 -UN-09MAY97

CED,OUOE002,1549 -19-15JUN98-10/21

Adjust plate clearance to specification.

**Specification**

K4 Clutch Pack—Clearance..... 1.2—1.4 mm (0.047—0.055 in.)

*NOTE: For the adjustment of the plate clearance there are snap rings of different thickness available through parts system that can be used if proper clearance is unable to be obtained! To ensure proper measuring result, install plates temporarily without oil.*

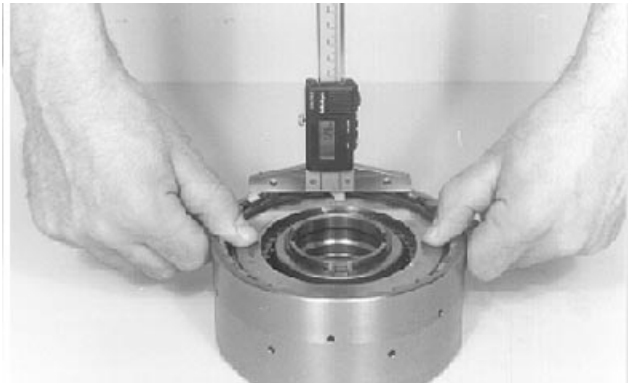

03  
0350  
53

T108986 -UN-14APR97

Press end shim and measure the dimension from the end face/plate carrier to the end shim with depth gauge.  
Record dimension (No. 1).

Example for Clutch Pack Clearance Check	
Dimension No. 1	7.20 mm (0.283 in.)
Dimension No. 2	6.00 mm (0.236 in.)
Difference = Plate Clearance	1.2 mm (0.047 in.)
Specification = Pack Clearance	1.2—1.4 mm (0.047—0.055 in.)

Continued on next page

CED,OUOE002,1549 -19-15JUN98-11/21

Loosen hex. head screws and remove oil feed housing.  
Remove flat gasket.

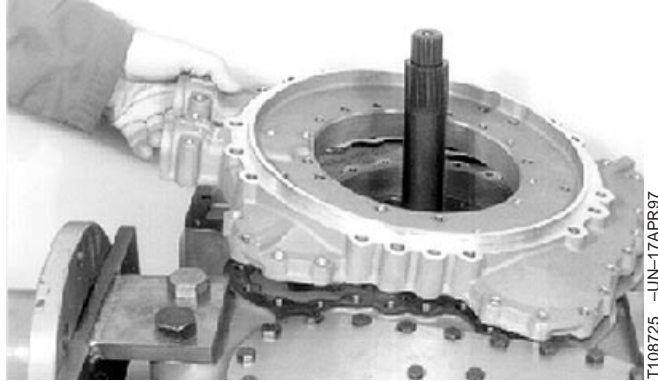

TX,0360,ME278 -19-21MAY98-5/5

T108725 -UN-17APR97

### Remove And Install Converter Minimum Pressure Regulator Valve

Remove converter minimum pressure regulator valve out of the housing bore.

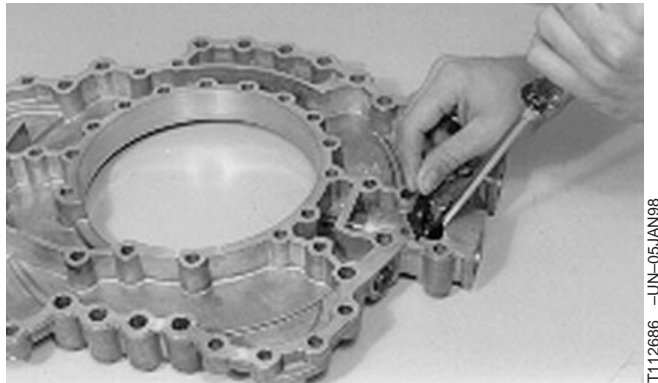

TX,0350,ME279 -19-21MAY98-1/2

T112686 -UN-05JAN98

03  
0360  
3

Inspect and replace parts as required.

*NOTE: Install pressure plate facing toward lock plate as show in photo.*

Install converter minimum pressure regulator valve into housing bore.

- 1—Piston
- 2—Compression Spring
- 3—Pressure Plate
- 4—Lock Plate

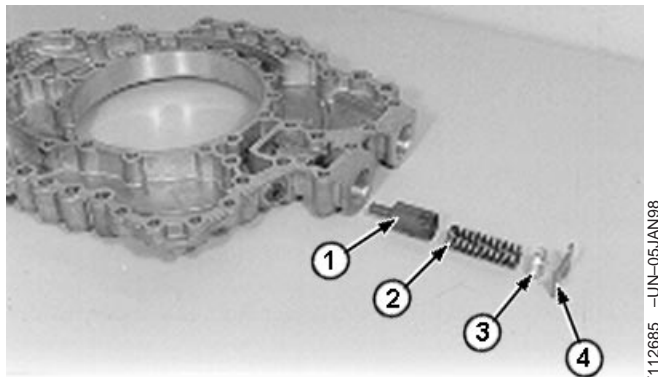

Minimum Pressure Regulator Valve

TX,0350,ME279 -19-21MAY98-2/2

T112685 -UN-05JAN98

12. Loosen screw to housing (9), remove housing and gasket (10).
13. Remove three pressure control valve pistons (29) and compression springs (30).
14. Remove three damping valve pistons (11) and compression springs (12).
15. Remove pressure reducing valve piston (14) compression spring (13).
16. Inspect and replace parts as necessary.

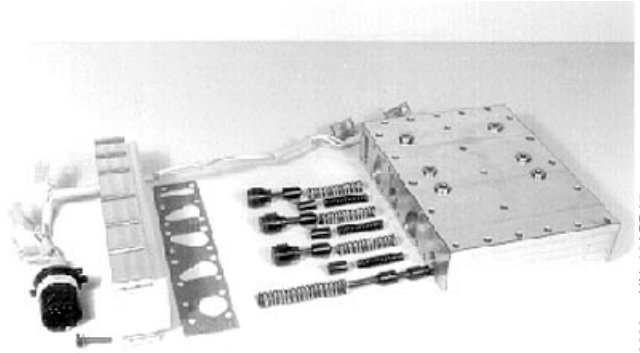

T108683 -JUN-16APR97

03  
0360  
13

TX,0360,ME274 -19-21MAY98-7/7

### Assemble Transmission Control Valve

1. Check all components for damage and replace if necessary.
2. Prior to the installation, check free travel of moving parts in the housing.
3. Oil components prior to the reassembly.
4. Insert orifices (31) (if removed) until contact is obtained (6 pieces, see arrows).
5. Install screens (37) if removed (Transmission S.N. 000588—)

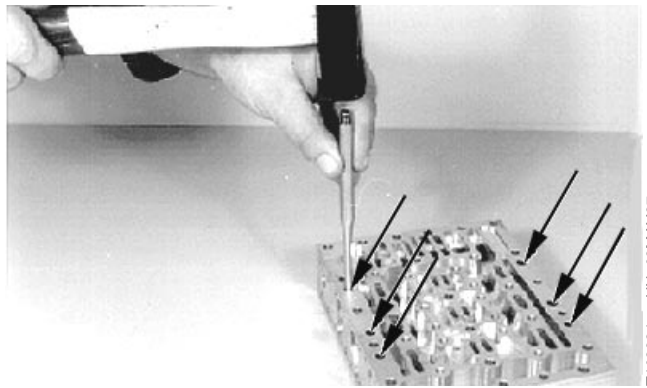

T108684 -JUN-09MAY97

TX,0360,ME275 -19-21MAY98-1/21

6. Install three pressure control valve pistons (29) and compression springs (30).
7. Install three damping valve pistons (11) and compression springs (12).
8. Install system Pressure reducing valve piston (14) compression spring (13).

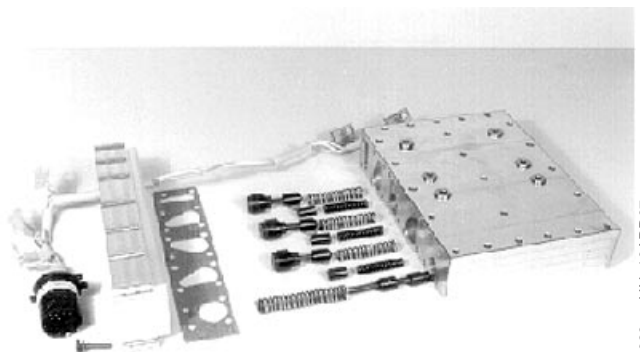

T108683 -JUN-16APR97

Continued on next page

TX,0360,ME275 -19-21MAY98-2/21

**DFT1149 Pre-Load Clutch Pack Compression Ring Tool**

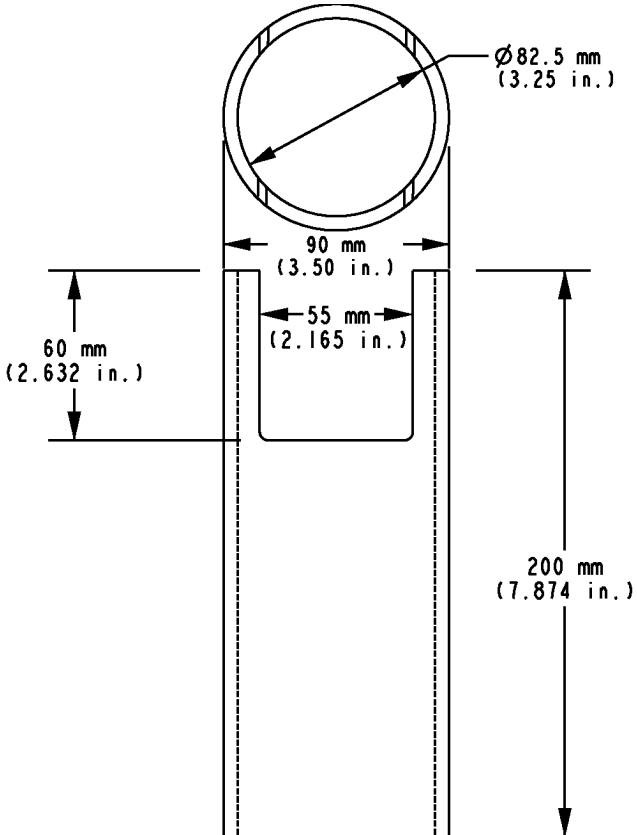
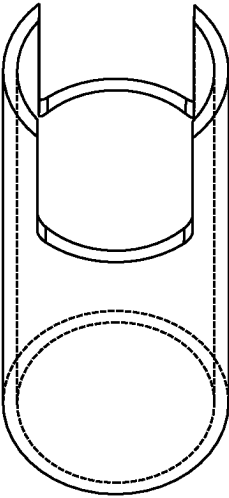

T109434

The Clutch Pack Compression Ring Tool is used to compress the piston compression ring so snap ring can be removed.

Material is standard pipe (see dimensions above) with window cut out to allow for access when removing snap ring.

TX,0399,ME296 -19-08MAY97-1/1

03  
0399  
1  
T109434 -UN-07MAY97

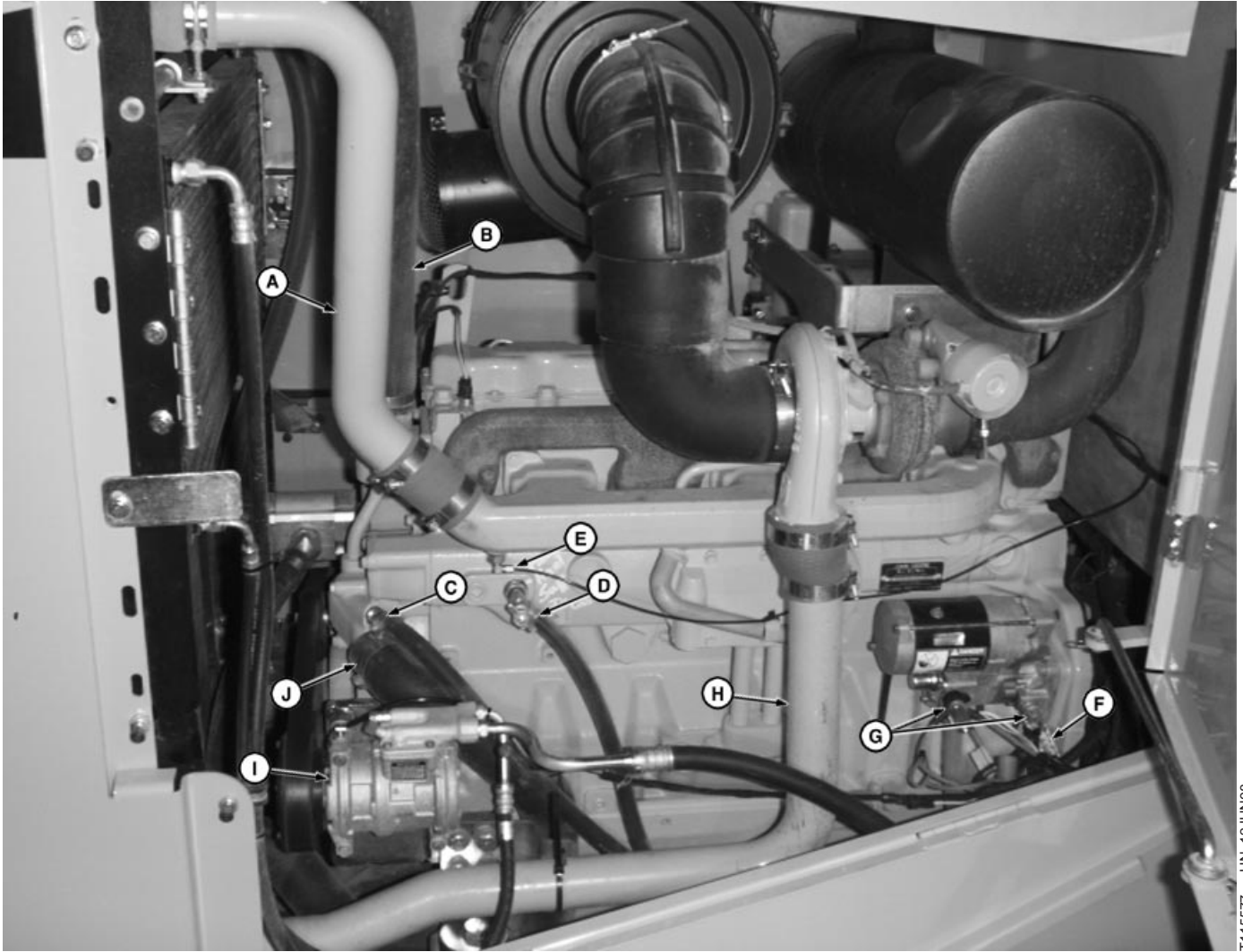

04  
0400  
5

T115577 -UN-12JUN98

A—Upper Air-to-Air Cooler  
B—Upper Radiator Hose  
C—Cab Return Heater Hose

D—Cab Inlet Heater Hose  
E—Fuel Starting Aid Line  
F—Ground Strap

G—Battery Cables  
H—Lower Air-to-Air Cooler  
I—Air Conditioning  
Compressor

J—Lower Radiator Hose

14.

Continued on next page

CED,OUOE002,1562 -19-03SEP02-5/10

CLICK HERE TO **DOWNLOAD** THE COMPLETE MANUAL

- Thank you very much for reading the preview of the manual.
- You can download the complete manual from: [www.heydownloads.com](http://www.heydownloads.com) by clicking the link below



- Please note: If there is no response to CLICKING the link, please download this PDF first and then click on it.

CLICK HERE TO **DOWNLOAD** THE COMPLETE MANUAL

## Remove And Install Engine Coolant Heater

**CAUTION:** Coolant may be hot. Wait until radiator is cool to the touch before draining.

1. Drain cooling system.

**Specification**

Cooling System—Capacity..... 29 L (31 qt)

2. Remove power cord (A). Loosen nut (C) and pull heating element (G) from block.

**CAUTION:** DO NOT plug coolant heater into electrical power unless heating element is immersed in coolant. Sheath could burst and result in personal injury.

Use a heavy-duty grounded cord to connect coolant heater to electrical power.

3. Disassemble parts (B—G).
4. Replace parts as necessary.
5. Assemble parts (A—G). Put heating element in cylinder block so flats on threaded portion of element are vertical.
6. Turn element clockwise and then counterclockwise until element contacts casting. Move element to the center position.
7. Hold element using a wrench. Tighten nut.

**Specification**

Engine Coolant Heater Nut—  
Torque ..... 34 N•m (25 lb-ft)

8. Install power cord (A).



T6642EK -UN-01NOV88

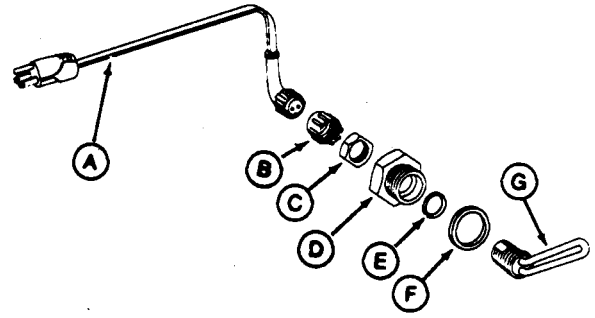

T6427AO -UN-21OCT88

- A—Power Cord
- B—Cap
- C—Nut
- D—Adapter
- E—Gasket
- F—O-Ring
- G—Heating Element

05  
0505  
3

Continued on next page

CED,OUOE002,1568 -19-26MAY98-1/2

## Cooling System

6. Disconnect upper (B) and lower (E) radiator hoses and hose to coolant recovery reservoir.
7. Disconnect transmission and hydraulic oil cooler hoses (C, D, G, and H).
8. Disconnect upper (A) and lower (F) air-to-air cooler tubes.

A—Upper Air-to-Air Cooler Tube  
B—Upper Radiator Hose  
C—Oil Cooler Outlet Hose  
D—Transmission Cooler Outlet Hose  
E—Lower Radiator Hose  
F—Lower Air-to-Air Cooler Tube  
G—Oil Cooler Inlet Hose  
H—Transmission Cooler Inlet Hose

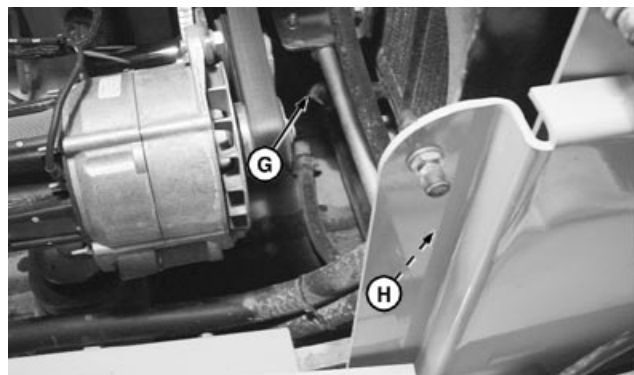
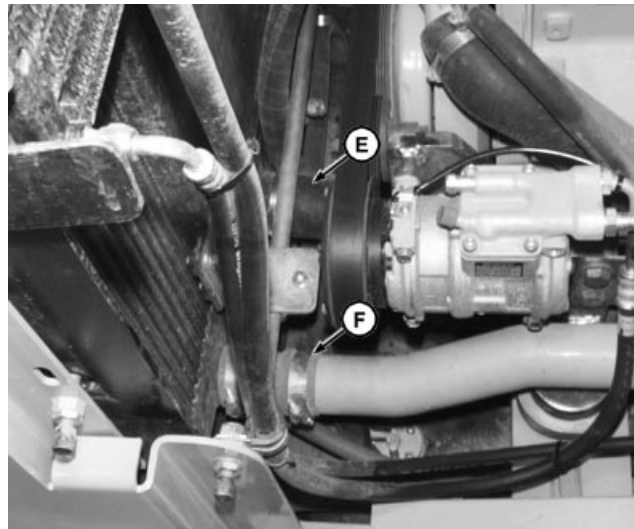
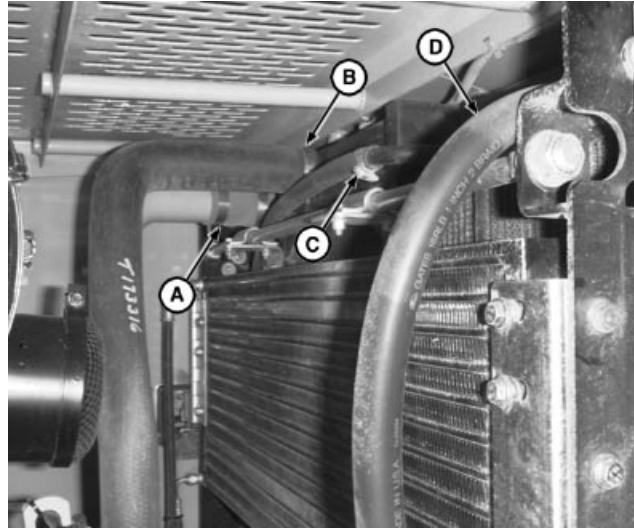

Continued on next page

CED,OUOE002,1572 -19-23AUG02-3/12

05  
0510  
9

3. Apply foam strips (A) to both sides of radiator (4 pieces required).

**A—Foam Strip (4 used)**



T111950 -UN-19NOV97

TX,05,RP3341 -19-23AUG02-3/7

4. Assemble side plate (B) to oil cooler (C).

**B—Side Plate**  
**C—Oil Cooler**



T109356B -UN-30APR97

Continued on next page

TX,05,RP3341 -19-23AUG02-4/7

05  
0510  
19

## Intake System

1—Band (2 used)	8—Cap	14—Filter Element	20—Nut
2—Washer (4 used)	9—Elbow Fitting	15—Cover	21—Clamp
3—Screw (4 used)	10—Adapter	16—Valve	22—Precleaner
4—Air Cleaner Housing	11—O-Ring	17—Air Cleaner Assembly	23—Screw (4 used)
5—Clamp	12—Air Filter Restriction Sensor	18—Nut (4 used)	24—Tube
6—Valve	13—Filter Element	19—Plate	25—Spring
7—Clamp			

### (S.N. 585561—)

1. Remove four screws (3) and bands (1).
2. Disconnect wiring harness connector from air filter restriction switch.
3. Remove and install parts as needed.
4. Inspect elements for wear or damage and replace as necessary.
5. Install parts.
6. Connect wiring harness connector to air filter restriction switch.

TX,0520,111296 -19-27MAY98-5/6

7. Tighten hose clamps (A and B) until air intake hose protrudes around clamp band.
8. Test air intake system. (See Air Intake System Leakage Test in this group.)

A—Clamp  
B—Clamp

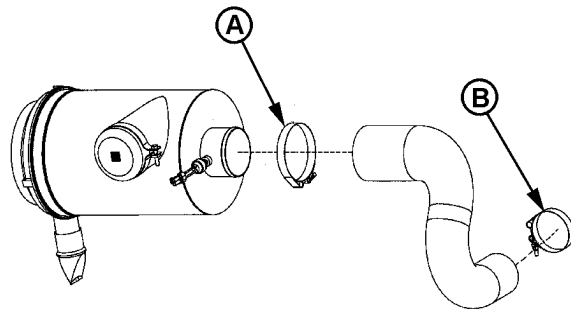

T108196

UN-17MAR97

TX,0520,111296 -19-27MAY98-6/6

05  
0520  
5

*External Fuel Supply Systems*

- |                          |                          |                        |                         |
|--------------------------|--------------------------|------------------------|-------------------------|
| 1—Fuel Tank              | 9—Sender                 | 17—Bolt (4 used)       | 25—Clamp                |
| 2—Drain Valve            | 10—Screw (5 used)        | 18—Flange Nut (4 used) | 26—Hose                 |
| 3—Elbow Fitting (2 used) | 11—Clamp                 | 19—Screw (2 used)      | 27—Screw                |
| 4—Clamp (2 used)         | 12—Hose (as needed)      | 20—Clamp (2 used)      | 28—Clamp                |
| 5—Clamp (8 used)         | 13—Filler Neck           | 21—Hose                | 29—Adapter              |
| 6—Elbow Fitting          | 14—Hose Fitting (2 used) | 22—Clamp (2 used)      | 30—Filler Neck Assembly |
| 7—Elbow Fitting          | 15—Filler Cap            | 23—Hose (as needed)    | 31—Fuel Tank            |
| 8—Gasket                 | 16—O-Ring                | 24—Hydraulic Hose      |                         |

Continued on next page

CED.OUOE002.1588 -19-27MAY98-2/7

05  
0560  
3

# Section 09 Steering System

## Contents

### Page

#### Group 0960—Hydraulic System

Essential Tools . . . . .	09-0960-1
Service Equipment and Tools . . . . .	09-0960-1
Other Material . . . . .	09-0960-1
Specifications . . . . .	09-0960-2
Steering Valve	
Remove and Install . . . . .	09-0960-3
Steering Column	
Remove and Install . . . . .	09-0960-8
Steering Cylinder	
Remove and Install . . . . .	09-0960-9
Disassemble and Assemble Steering	
Cylinder . . . . .	09-0960-10
Steering Cylinder Bushings	
Remove and Install . . . . .	09-0960-10

## Remove And Install Steering Cylinder

**CAUTION:** Prevent possible injury from unexpected machine frame movement. Install frame locking bar to both frames before you work in the frame pivot area.

Escaping fluid under pressure can penetrate the skin causing serious injury. Avoid the hazard by relieving pressure before disconnecting hydraulic or other lines. Tighten all connections before applying pressure. Search for leaks with a piece of cardboard. Protect hands and body from high pressure fluids.

If an accident occurs, see a doctor immediately. Any fluid injected into the skin must be surgically removed within a few hours or gangrene may result. Doctors unfamiliar with this type of injury should reference a knowledgeable medical source. Such information is available from Deere & Company Medical Department in Moline, Illinois, U.S.A.

1. Install frame locking bar (C). Stop engine.
2. Turn steering wheel back and forth to release hydraulic pressure in the system.
3. Disconnect lines from cylinder. Close all openings using caps and plugs.

**CAUTION:** The approximate weight of the steering cylinder is 28 kg (61 lb).

### Specification

Steering Cylinder—Weight ..... 65 kg (143 lb) approximate

4. Remove pin from rod and head end of cylinder.
5. Remove cylinder from unit.
6. See Disassemble Cylinder. TMH120A. (Group 01) See Assemble Cylinder. TMH120A. (Group 01)
7. Install cylinder and connect lines.

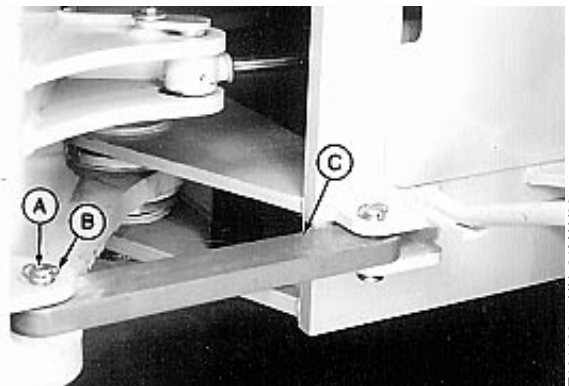
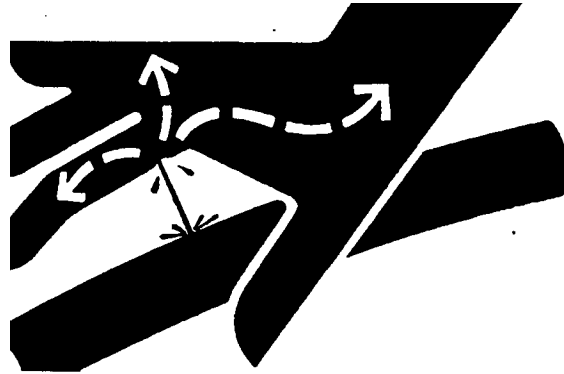

A—Pin  
B—Retaining Ring  
C—Frame Lock Bar

X9811 -UN-23AUG88

T101186 -UN-21MAY96

09  
0960  
9

## Hydraulic System

### Specification

Brake Accumulator Nitrogen

Charge—Pressure..... 1137 kPa (11.4 bar) (165 psi)

4. With machine OFF apply brakes approximately 30 times to discharge both brake accumulators.
5. Remove shielding trim on front and right side of cab for access.
6. Remove clamp and return hose from brake valve.

TX,1060,JC2284 -19-25JUN98-3/4

7. Pinch off return hose (A) with vise grip to stop reservoir hydraulic oil from draining back.
8. Disconnect hoses and electric connectors.
9. Remove cap screws and brake valve.
10. Replace parts as necessary.
11. Install brake valve.
12. Connect hoses and electric connectors.
13. Check for slight clearance between brake valve plunger and roller spinning freely on brake pedal.

**A—Return Hose**

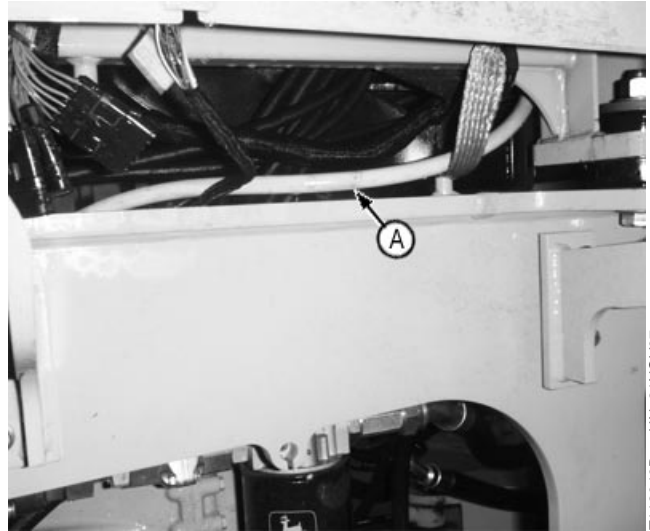

T112343B -UN-21NOV97

TX,1060,JC2284 -19-25JUN98-4/4

10  
1060  
3

Active Elements

- 1—Brake
- 2—Plate
- 3—Gasket
- 4—Housing
- 5—Bearing (2 used)
- 6—Bearing Cup
- 7—Bearing Cone
- 8—Universal Driveshaft
- 9—Snap Ring

- 10—Washer
- 11—Yoke
- 12—Washer
- 13—Nut
- 14—Retainer
- 15—Seal (2 used)
- 16—Seal (2 used)
- 17—Fitting (2 used)
- 18—Relief Valve

- 19—O-Ring (2 used)
- 20—Spring (16 used)
- 21—Compression Spring (18 used)
- 22—Pin (2 used)
- 23—Brake Disk
- 24—Piston
- 25—O-Ring
- 26—O-Ring

- 27—Screw (6 used)
- 28—Brake Disk (7 used)
- 29—Brake Disk (7 used)
- 30—Washer (4 used)
- 31—Cap Screw (4 used)
- 32—Yoke
- 33—Elbow Fitting
- 34—O-Ring
- 35—O-Ring

1. Remove nut (13), washer (12) and yoke (11).

**CAUTION: Cover and cap screws are under pressure. Remove cap screws evenly to avoid possible injury.**

2. Remove cap screws (27) evenly.

3. Remove cover plate (2) from housing (4).

4. Remove shaft with brake disks (28) and separator plates (29).

5. Remove brake disk (23) from housing.

6. Remove springs (20), compression springs (21) and spring retainer (14).

7. Remove seals (15 and 16) from housing.

8. Remove bearing cup (6).

9. Remove piston (24) from cover plate.

10. Remove O-rings (25 and 26) from piston.

11. Remove seals (15 and 16) and bearing cup (6) from cover plate.

CED,OUOE002,1601 -19-27MAY98-2/7

12. Remove bearing cone (A) using a bearing puller from one end of shaft.

13. Remove bearing, disks, and plates from shaft.

14. Press other bearing off shaft.

15. Replace parts as necessary.

16. Press bearing cup (6) against shoulder in cover plate.

17. Lubricate O-rings (25 and 26) and piston (24) with J20C oil. Install inner and outer O-rings on piston.

A—Bearing Cone

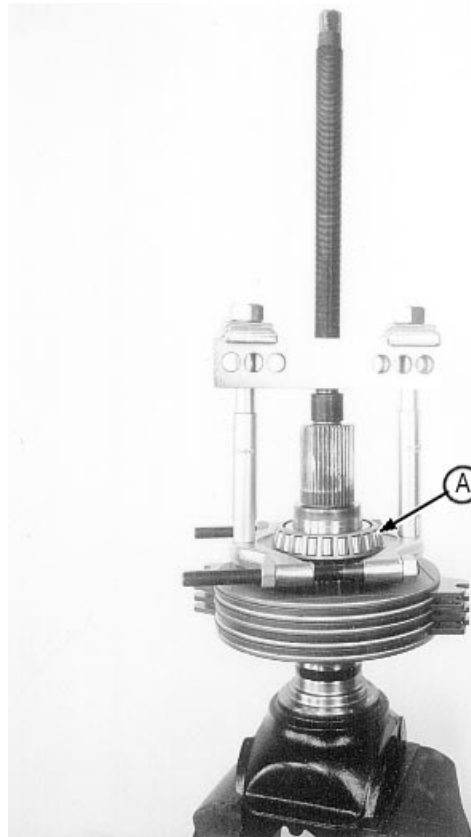

Continued on next page

CED,OUOE002,1601 -19-27MAY98-3/7

T112152 -UN-06NOV97

11  
1111  
5

## Weld Major Structure



**CAUTION:** Avoid potentially toxic fumes and dust. Hazardous fumes can be generated when paint is heated by welding, soldering, or using a torch. Do all work outside or in a well ventilated area. Dispose of paint and solvent properly.

If you sand or grind paint, avoid breathing the dust. Wear an approved respirator. If you use solvent or paint stripper, remove stripper with soap and water before welding. Remove solvent or paint stripper containers and other flammable material from area. Allow fumes to disperse at least 15 minutes before welding or heating.



TSS220 -JUN-23AUG88

Remove paint before welding.

**IMPORTANT:** Disconnect battery ground strap or turn battery disconnect switch to OFF (if applicable).

Disconnect both negative and positive battery cables and microprocessor unit (if applicable).

**IMPORTANT:** Have only a qualified welder do this job. Connect welder ground clamp close to each weld area so electrical current does not pass through any bearings.

Remove or protect all parts that can be damaged by heat or weld splatter.

Use one of the following weld processes:

- AWS-E-7018 covered electrode with shielded metal arc welding (SMAW) process.
- AWS-ER-70S-3f wire electrode with gas metal arc welding (GMAW) process.
- AWS-E70T-1 or E71T-1 wire electrode with flux core arc welding (FCAW) process.

Continued on next page

TX,17,RP3351 -19-04JUN98-1/2

## Frame Installation

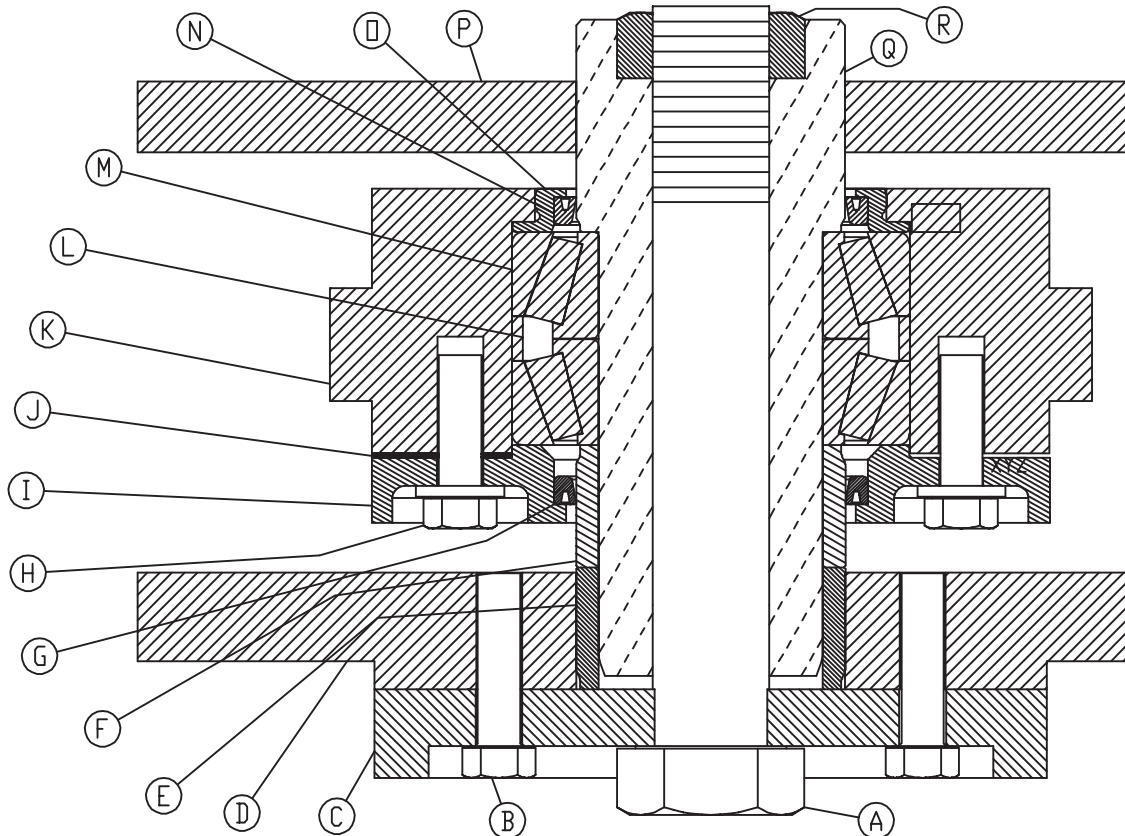

T154053

Lower Pivot Bearing and Seal (S.N 583403—)

A—Pin Retaining Cap Screw	F—Spacer (Engine Frame)	K—Loader Frame	O—Spacer
B—Cap Screw (6 used)	G—Cover Seal	L—Bearing Spacer	P—Loader Frame
C—Plate	H—Cap Screw (6 used)	M—Bearing (2 used)	Q—Lower Pivot Pin
D—Engine Frame	I—Cover	N—Spacer Seal	R—Nut
E—Spacer (Engine Frame)	J—Shims (as needed)		

1. Remove pin retaining cap screw (A), cap screws (B) and plate (C). Remove pivot pin (Q) and separate machine frames.
  2. Remove cap screws (H), cover (I) with seal (G) and spacers (J).
- NOTE: Spacer seal can not be pushed through spacer. Remove seal and spacer to remove seal.*
3. Remove (L, M, N and O) from engine frame, using a puller disk against seal spacer (O). Remove seal (N) from seal spacer (O).
  4. Remove spacer (E) from engine frame bore.
  5. Replace parts as necessary.
  6. Press spacer (E) into engine frame bore flush with bottom of frame.
  7. Apply a light coat of JDM J13E4 grease to rollers in bearings (M).
  8. Press seal into seal spacer, with lips facing out. Seal must seat against the seal spacer shoulder.
  9. Install seal spacer to bottom of bore.
  10. Press first bearing cup into engine frame bore against spacer.

Continued on next page

CED,OUOE002.1623 -19-18APR02-2/3



**CAUTION:** Escaping fluid under pressure can penetrate the skin causing serious injury. Avoid the hazard by relieving pressure before disconnecting hydraulic or other lines. Tighten all connections before applying pressure. Search for leaks with a piece of cardboard. Protect hands and body from high pressure fluids.

If an accident occurs, see a doctor immediately. Any fluid injected into the skin must be surgically removed within a few hours or gangrene may result. Doctors unfamiliar with this type of injury should reference a knowledgeable medical source. Such information is available from Deere & Company Medical Department in Moline, Illinois, U.S.A.

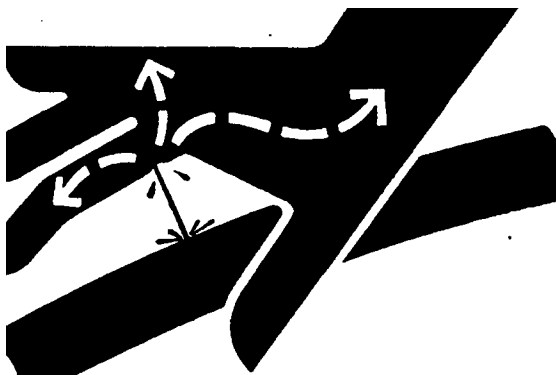

X9811 -UN-23AUG88

18  
1800  
3

- Disconnect the five hoses (A) from steering valve. Plug and cap hoses.

A—Hose (5 used)

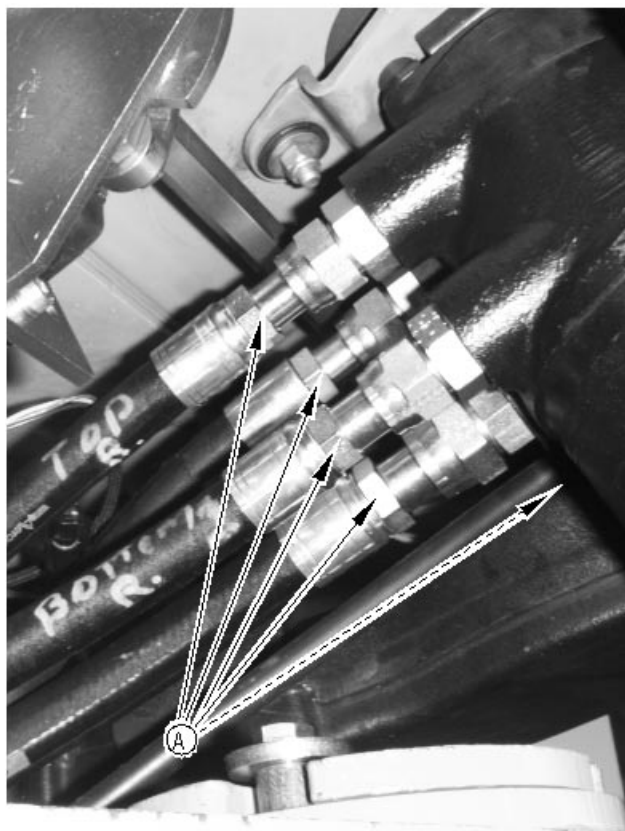

T104543C -UN-07MAR97

CED,OUOE002,1635 -19-05JUN98-3/7

- Disconnect brake valve return hose (A) and brake valve work port hoses (B). Plug and cap hoses.

A—Brake Valve Return Hose  
B—Brake Valve Work Port Hose

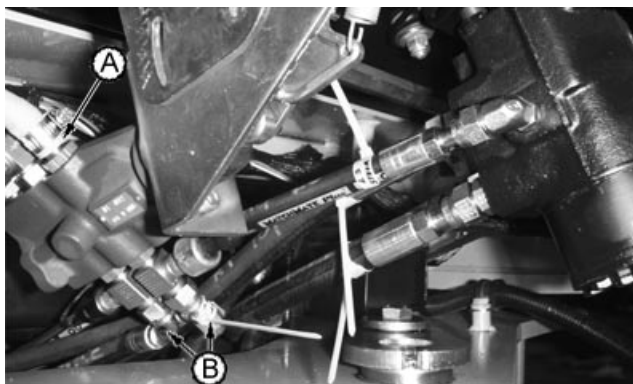

T107920B -UN-24MAR97

Continued on next page

CED,OUOE002,1635 -19-05JUN98-4/7

## R134a Refrigerant Recovery, Recycling And Charging Station Installation Procedure

**CAUTION:** Do not remove high pressure relief valve (A). Air conditioning system will discharge rapidly causing possible injury.

**IMPORTANT:** Use correct refrigerant recovery, recycling and charging stations. **DO NOT** mix refrigerant, hoses, fittings, components or refrigerant oils.

*NOTE: JT02046 and JT02050 recovery and charging stations can be substituted for the JT02045 station.*

1. Close both high and low pressure valves on refrigerant recovery, recycling and charging station (H).
2. Remove cap from low pressure test port (G).
3. Connect low pressure blue hose (D) from refrigerant recovery, recycling and charging station (H) to low pressure test port (G) on compressor.
4. Connect high pressure red hose (C) to high pressure quick disconnect (B).
5. Follow the manufacturer's instructions when using the refrigerant recovery, recycling and charging station.

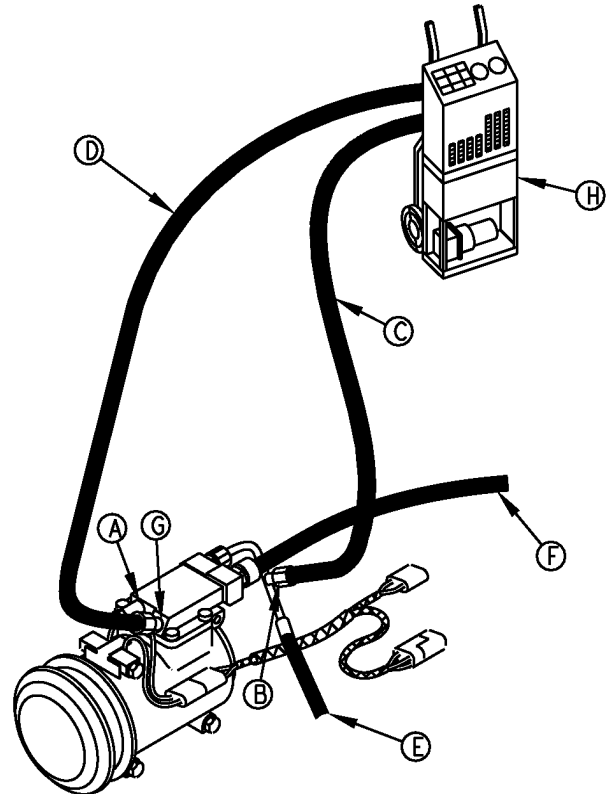

T110345

- A—High Pressure Relief Valve
- B—High Pressure Test Port
- C—Red Hose
- D—Blue Hose
- E—High Pressure Hose
- F—Low Pressure Hose
- G—Low Pressure Test Port
- H—Refrigerant Recovery/Recycling and Charging Station

18  
1830  
5

T110345 -UN-09JUL97

CED,OUOE003,1026 -19-24JUL98-1/1

Heating And Air Conditioning

1—Nut	18—Resistor	35—Bolt	52—O-Ring
2—Seal	19—Cover	36—Hose	53—Ring
3—Impeller	20—Housing, Heater Module	37—Plate	54—O-Ring
4—Pressurizer Blower Motor	21—Screw	38—Housing	55—O-Ring
5—Cap Screw	22—Isolator	39—Valve	56—A/C Low Pressure Switch
6—Tube	23—Filter	40—Valve	57—Grommet
7—Screw	24—Nut	41—Hose	58—Grommet
8—Clamp	25—Housing	42—Tube	59—Clip
9—Tube	26—Latch	43—Clamp	60—Cable
10—Bracket	27—Rivet	44—Tube	61—Lock Washer
11—Air Duct	28—Filter Element	45—Tube	62—Nut
12—Tie Band	29—Pressurizer Blower Motor	46—Tube	63—Knob
13—Clip	30—Seal	47—A/C High Pressure Switch	64—Control
14—Thermostat	31—Evaporator Core	48—Screw	65—Seal
15—Air Duct	32—Air Duct	49—Plate	66—Hose
16—Air Plenum	33—Hose	50—Screw	67—Gasket
17—Screw	34—Knob	51—Plug	

18  
1830  
15

CED,OUOE003,1031 -19-24JUL98-2/2

## Remove And Install Receiver-Dryer And Condenser

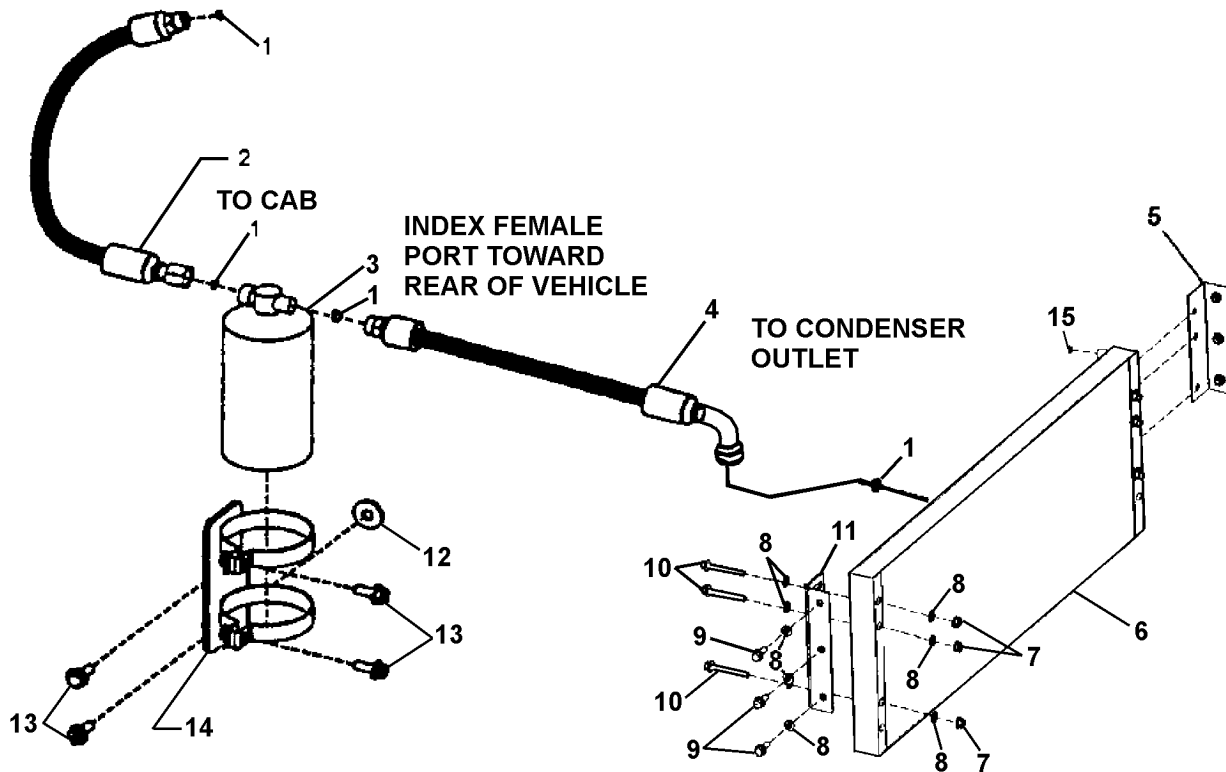

T112716

- |                   |                   |            |            |
|-------------------|-------------------|------------|------------|
| 1—O-Ring (4 used) | 5—Hinge           | 9—Screw    | 13—Screw   |
| 2—Hose            | 6—Vapor Condenser | 10—Screw   | 14—Bracket |
| 3—Receiver-Dryer  | 7—Nut, Flange     | 11—Bracket | 15—O-Ring  |
| 4—Hose            | 8—Washer          | 12—Washer  |            |

### Receiver Dryer:

1. Recover refrigerant. (See procedure in this group.)
2. Discharge the system.
3. Disconnect lines (2 and 4) from receiver-dryer.
4. Remove receiver-dryer.

**IMPORTANT:** A new receiver-dryer must always be installed after purging the system. DO NOT use a flushed or used receiver/dryer. Contamination of system can cause component failure.

5. Apply refrigerant oil to new O-rings. Remove plugs from receiver-dryer and immediately connect lines (2 and 4).
6. Add 15 mL (0.5 fl. oz.) refrigerant oil to system. See procedure in this group.)
7. Evacuate and charge the system. (See procedure in this group.)

### Condenser:

1. Recover refrigerant. (See procedure in this group.)
2. Disconnect the condenser-to-compressor hose and condenser-to-receiver-dryer hose.

Continued on next page

CED,OUOE003,1032 -19-24JUL98-1/2

18  
1830  
25

T112716 -19-06JAN98

3. Hold the clutch hub using JDG747 Compressor Clutch Spanner (A) and remove the clutch shaft bolt (B).
4. Remove the clutch hub (C). Remove the shims (H) from the clutch hub and save for installation.
5. Remove and discard snap ring (D). Remove the pulley (E) using a plastic hammer or JDG220 Puller, JDG748 Jaws, and JDG771 Forcing Screw.
6. Disconnect the clutch coil lead wire. Remove and discard the snap ring (F) and remove the clutch coil (G).

*NOTE: The bearing in the pulley is NOT serviceable.*

7. Check pulley bearing operation. Replace pulley and bearing as required.

8. Install the clutch coil and new snap ring with flat side of the snap ring down. Connect the clutch coil lead wire.
9. Install the pulley and new snap ring with flat side of the snap ring down. Apply grease to the shims (H) and install to the clutch hub.
10. Install clutch hub and shaft bolt and tighten. Install dust cover.

**Specification**

Clutch Hub Shaft Bolt—Torque .....	14 N•m (120 lb-in.)
Compressor Clutch Coil—	
Current Draw .....	2.8—3.5 amps at 24 Volts 20°C (68°F)
Resistance .....	2.8—4.5 ohms at 20°C (68°F)
Compressor Relief Valve—	
Pressure.....	Opens at 3030 kPa (30 bar) (440 psi)

TX,18,DY5297 -19-09MAY97-2/2

**Check Clutch Hub Clearance—R134a**

*NOTE: The clutch coil is NOT polarity sensitive.*

1. Check pulley-to-clutch hub clearance using a dial indicator. Mount the gauge to the pulley as illustrated and connect a set of jumper wires from the compressor to a 12V battery.
2. Rotate the pulley and check clearance in three equally spaced locations around the clutch hub. Correct clearance is 0.35—0.65 mm (0.014—0.026 in). Add or remove shims as required.

**Specification**

Pulley-to-Clutch Hub—Clearance..... 0.35—0.65 mm (0.014—0.026 in)

3. Tighten clutch shaft bolt to 14 N•m (120 lb-in.) after correct clearance is obtained.

**Specification**

Clutch Hub Shaft Bolt—Torque..... 14 N•m (120 lb-in.)



RW21159 -UN-24JUN92

TX,1830,BA636 -19-26MAR93-1/1

# Group 1910 Hood Or Engine Enclosure

## Remove And Install Hood

- 1—Hood
- 2—Washer (4 used)
- 3—Screw (4 used)

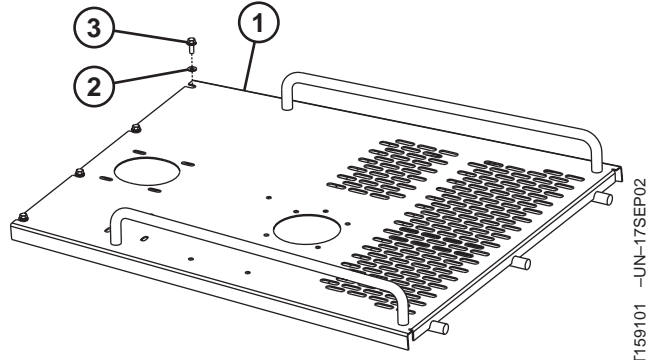

TX,19,1111039 -19-05JUN98-1/1

19  
1910  
1

## Ride Control Accumulator Safety

1. Stop engine.



**CAUTION:** Prevent possible injury from unexpected boom or bucket movement when equipped with ride control. Always be sure the ride control accumulator energy is discharged when working on hydraulic components. To do this: With boom raised slightly, turn ignition switch to ON position. Cycle the ride control switch from OFF to ON (center position). Boom will jump up unexpectedly if ride control accumulator is energized. Press boom enable switch and move the control lever into the float position and hold for 5 seconds.

2. If equipped with position). Boom ride control. With boom raised slightly, turn ignition switch to ON position. Cycle the ride control switch from OFF to ON (center will jump up unexpectedly if ride control accumulator is energized. Press boom enable switch and move the control lever into the float position and hold for 5 seconds.

## Remove And Install Loader Bucket Tilt Linkage

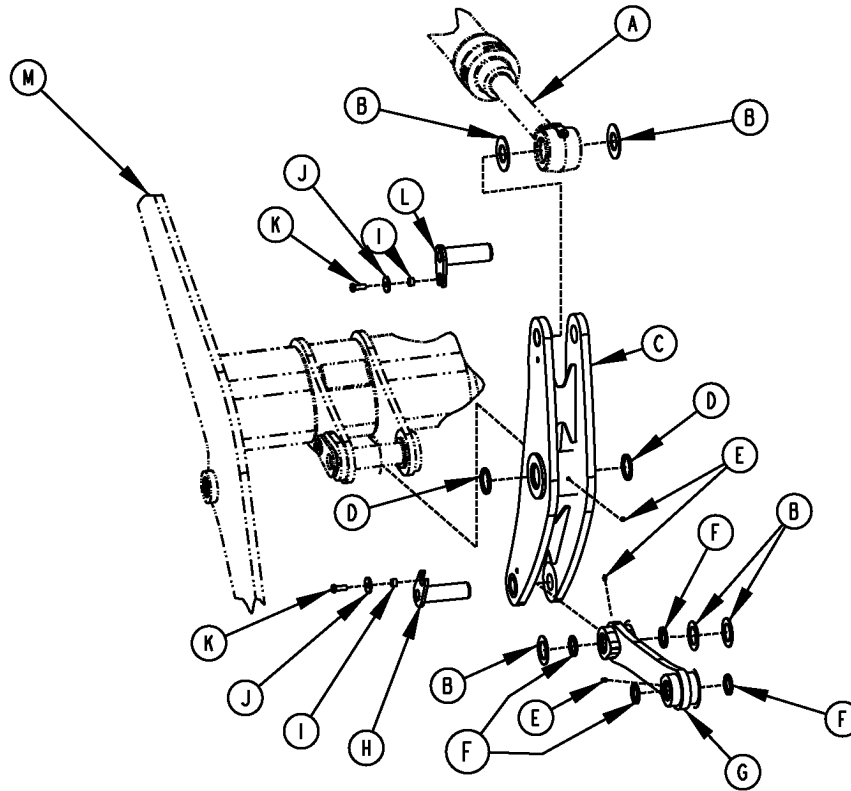

T108207

- |                      |                           |                   |                      |
|----------------------|---------------------------|-------------------|----------------------|
| A—Bucket Cylinder    | E—Grease Fitting (3 used) | H—Pin             | K—Cap Screw (2 used) |
| B—Shim (As Required) | F—Seal (4 used)           | I—Spacer (2 used) | L—Pin                |
| C—Bellcrank          | G—Bucket Link             | J—Washer (2 used) | M—Loader Boom        |
| D—Shim (As Required) |                           |                   |                      |

Lower bucket to the ground.

**CAUTION:** Approximate weight of bellcrank with bushings is 366 kg (806 lb).

Approximate weight of bellcrank pivot pin is 12 kg (26 lb).

Approximate weight of bucket link with bushings is 34 kg (75 lb).

### Specification

Bellcrank with Bushings—	
Weight.....	366 kg (806 lb) approximate
Bellcrank Pivot Pin—Weight.....	12 kg (26 lb) approximate
Bucket Link with Bushings—	
Weight.....	34 kg (75 lb) approximate

Remove parts as necessary.

Install shims (B) bellcrank-to-bucket link and bellcrank-to-bucket cylinder (D) bellcrank-to-loader boom to obtain maximum clearance.

### Specification

Bellcrank-to-Bucket Link—	
Clearance.....	3 mm (0.12 in.) maximum
Bellcrank-to-Bucket Cylinder—	
Clearance.....	3 mm (0.12 in.) maximum
Bellcrank-to-Loader Boom—	
Clearance.....	3 mm (0.12 in.) maximum

Apply NEVER-SEEZ® Lubricant or an equivalent to bore of bellcrank pivot pin.



**CAUTION:** Escaping fluid under pressure can penetrate the skin causing serious injury. Avoid the hazard by relieving pressure before disconnecting hydraulic or other lines. Tighten all connections before applying pressure. Search for leaks with a piece of cardboard. Protect hands and body from high pressure fluids.

If an accident occurs, see a doctor immediately. Any fluid injected into the skin must be surgically removed within a few hours or gangrene may result. Doctors unfamiliar with this type of injury may call the Deere & Company Medical Department in Moline, Illinois, or other knowledgeable medical source.

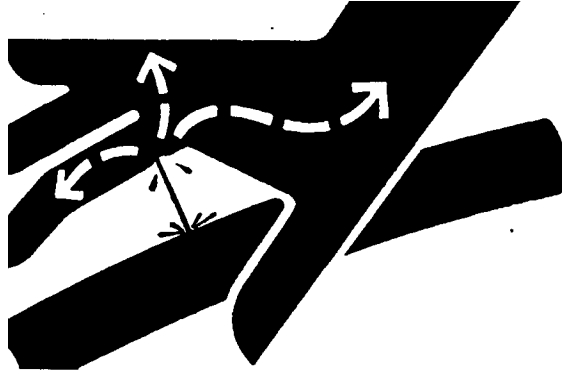

X9811 -UN-23AUG88

9. Drain hydraulic reservoir. Approximately 117 L (31 gal).

**Specification**

Hydraulic Reservoir—Capacity..... 117 L (31 gal) approximate

10. Remove transmission filter assembly (A). Move out of the way.

11. Disconnect transmission connector (B).



T115788 -UN-12JUN98

A—Transmission Filter Assembly  
B—Transmission Connector

31  
3160  
7

Continued on next page

CED,OUOE002,1659 -19-09JUN98-2/4

15. Remove flat head screws with a 5/32 Allen wrench and remove guide plate (A).

A—Guide Plate

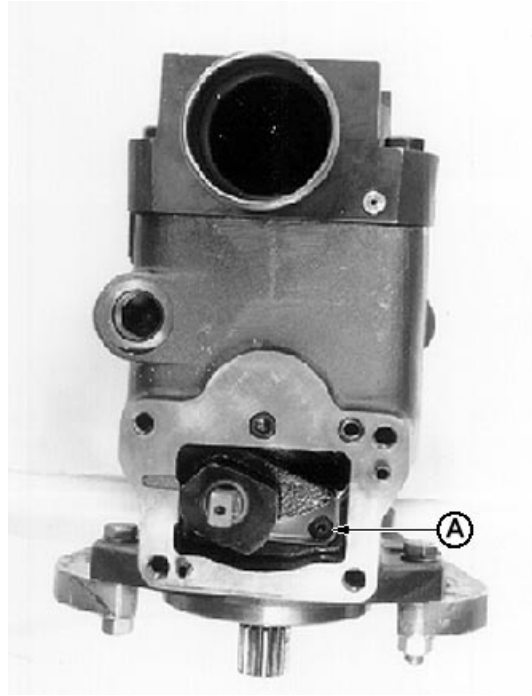

T104799 -UN-04NOV96

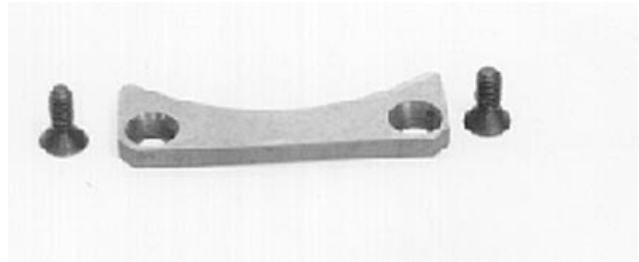

T103484 -UN-04NOV96

Continued on next page

CED,OUOE002,1661 -19-09JUN98-15/44

31  
3160  
17

40. Rotating Group

Place the cylinder barrel, wear surface down on a clean cloth. Place the shoe retainer spring in the center of the barrel with the fulcrum ball on top of it. Insert pistons into their corresponding (numbered) holes of the shoe retainer. As a unit, fit the pistons into their corresponding (numbered) bores in the cylinder barrel. **DO NOT FORCE.**

- A—Respective Piston Bore
- B—Shoe Assembly
- C—Shoe Retainer

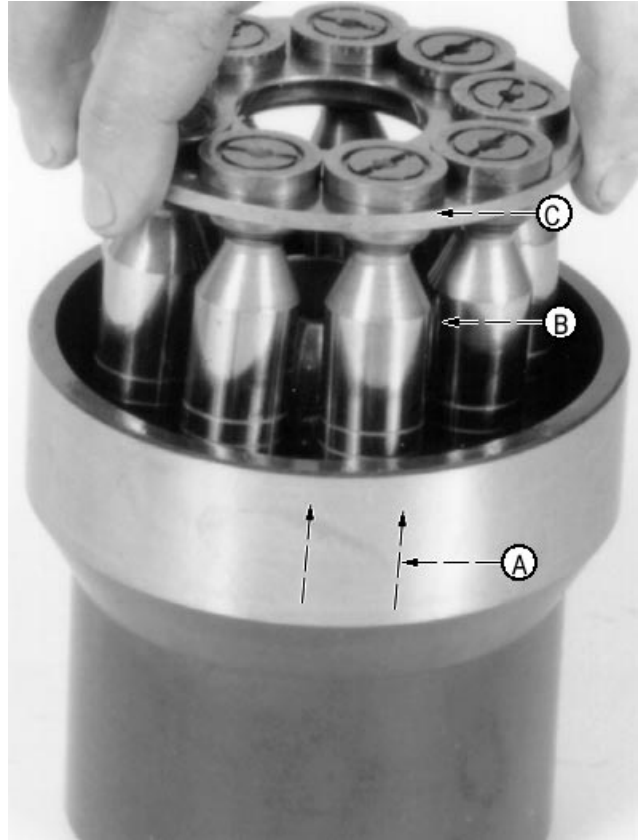

CEB,OUOE002,1661 -19-09JUN98-37/44

T104036 -UN-04NOV96

31  
3160  
27

41. Support the weight of the cylinder barrel as cylinder spline is passed over the tail shaft, to avoid scratching or damage. Push cylinder forward until the cylinder spline reaches the drive shaft spline and rotate the cylinder slightly to engage shaft splines. Continue to slide cylinder forward until it encounters the cylinder bearing. Lifting the tail shaft slightly helps cylinder and cylinder bearing engagement. Continue pushing cylinder forward until the piston shoes contact the swashblock.

At this point, the back of the cylinder should be located approximately 10.2 mm (0.4 in) outside the back of the pump housing.

*NOTE: Make sure the rotate group has spring action. This assures correct assembly in relation to the spline.*

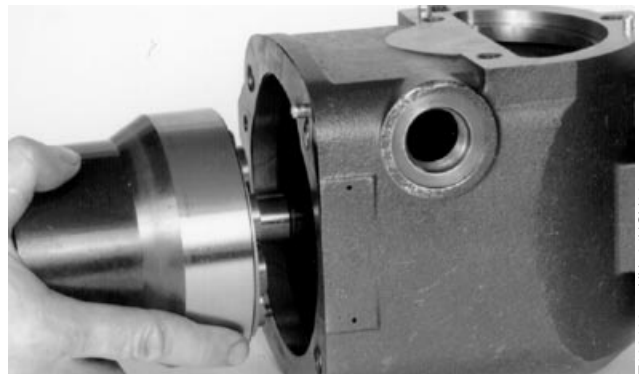

T103482 -UN-04NOV96

### Disassemble And Assemble Auxiliary Valve Section And Bucket Section

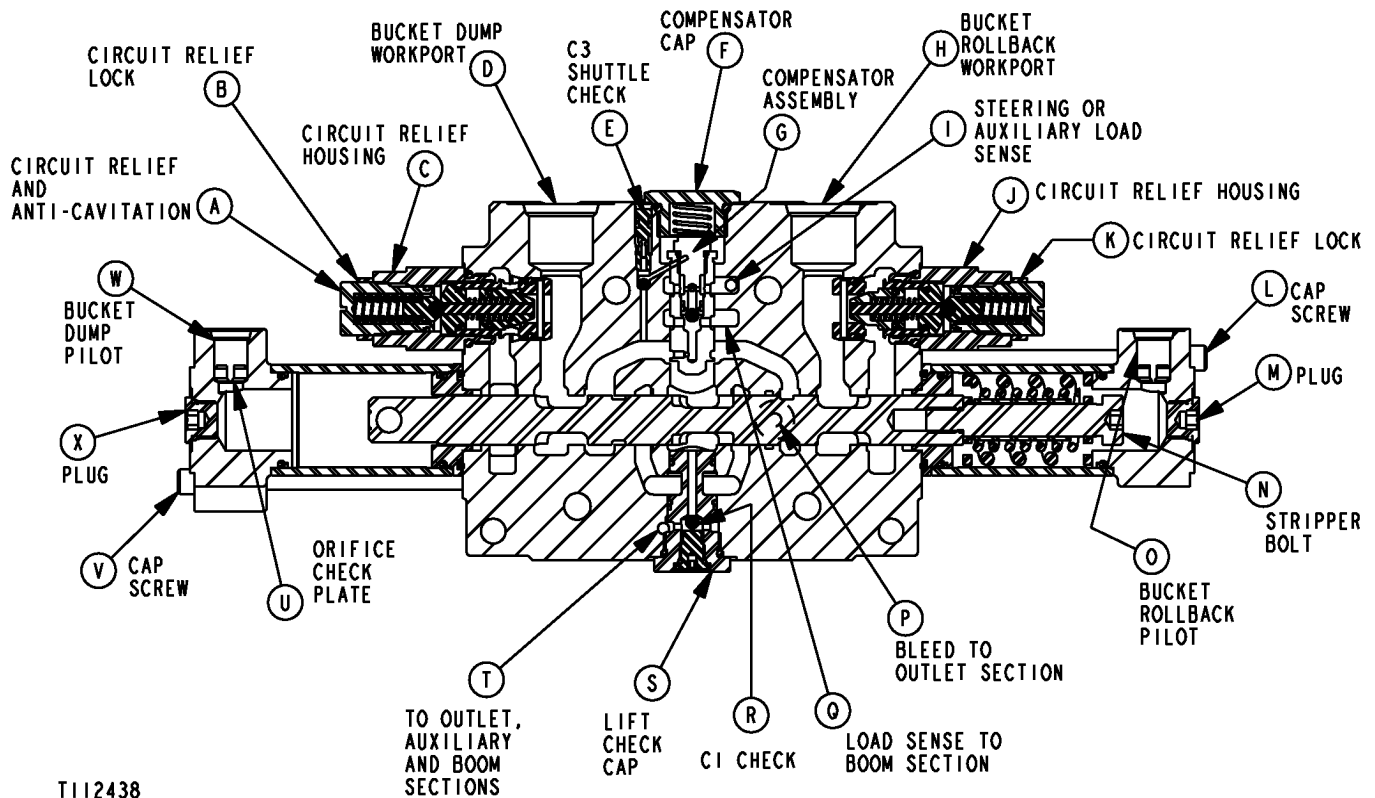

T112438

Bucket Section Shown

NOTE: Bucket valve section shown.

1. Disassemble valve.

**IMPORTANT: Coat all internal surfaces with clean hydraulic oil.**

2. Replace all O-rings and backup rings.

3. Apply thread lock and sealer (high strength) to the following components:

- Cap Screws (L and V).
- Stripper Bolt-to-Spool (N).

4. Torque components to specification.

**Auxiliary Valve Section:—Specification**

Circuit Relief Lock (B)—Torque.....	20 N•m (175 lb-in.)
Circuit Relief Housing (C)—Torque.....	102 N•m (75 lb-ft)
Compensator Cap (F)—Torque.....	102 N•m (75 lb-ft)
Hex Head Screw (J)—Torque .....	11 N•m (100 lb-in.)
Lift Check Hex Head Cap (O)—Torque.....	169 N•m (125lb-ft)
Socket Head Screw (S)—Torque.....	11 N•m (100 lb-in.)
Port Plug (T)—Torque .....	20 N•m (175 lb-in.)
Circuit Relief Cap (V)—Torque.....	115 N•m (85 lb-ft)

31  
3160  
37

T112438 -19-05DEC97

TX,31,RP3377 -19-09JUN98-1/1

## Hydraulic System

1—Grip	19—Push Bar	35—Retainer (2 used) (Tool Carrier 3 used)	46—Spring
2—Sleeve	20—Grommet (4 used)	36—Plunger (2 used) (Tool Carrier 1 used)	47—Spring
3—Nut	21—Strap (4 used)	37—Plunger (2 used) (Tool Carrier 3 used)	48—Housing
4—Retainer	22—Terminal Nipple (8 used)	38—Shim (as required) (0.1 mm / .004 in)	49—O-Ring
5—Boot	23—Washer	39—Shim (as required) (0.2mm / .007 in)	50—Plug
6—Nut (4 used)	24—Pin contact (8 used)	40—Shim (as required) (0.4mm / .015 in)	51—Plug (2 used)
7—Lever	25—Nut	41—Spool (2 used)	52—Valve
8—Set Screw	26—connector	42—Spool	53—Label
9—Washer	27—O-Ring	43—Spool	54—O-Ring (6 used)
10—Washer	28—Electrical Coil (3 used)	44—Spring	55—Adapter (5 used)
11—Plug	29—Retainer (3 used)	45—Feel Position Kit	56—O-Ring (6 used)
12—Plate	30—Tube		57—Adapter
13—Washer	31—Back Up Ring		58—Plate
14—Nut	32—Seal		59—Screw (4 used)
15—U-Join (center post)	33—Ring (2 used)		60—Locknut (3 used)
16—Ball joint socket (3 used)	34—Retainer (2 used) (Tool Carrier 1 used)		61—Nut
17—Cap Screw (4 used)			62—Spool
18—Housing (top)			

Item	Measurement	Specification
Lever Housing-to-Valve Housing Allen Screw	Torque	8.5 N•m (75 lb-in.)
Lever Adjuster Sleeve Hex Nut	Torque	11 N•m (100 lb-in.)
Universal Joint Hex Nut	Torque	28 N•m (250 lb-in.)

TX,31,ME155 -19-04SEP02-5/29

31  
3160  
47

### Replacing Quickshift Switch In Controller Lever

1. Remove Pilot Controller from machine.
2. Place controller in bench vice.
3. Slide boot and retainers (B) down with hands from grip at (A).

A—Grip  
B—Boot and Retainer

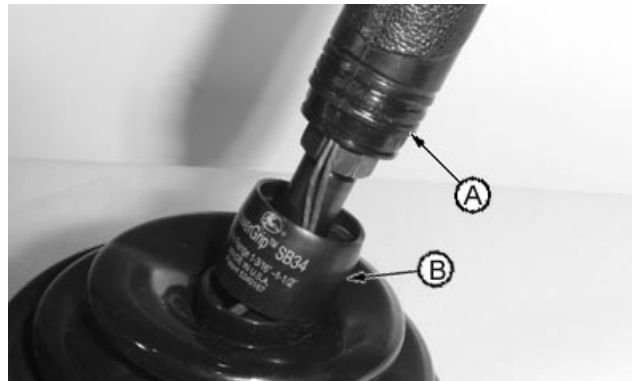

T1105756B -UN-19DEC96

Continued on next page

TX,31,ME155 -19-04SEP02-6/29

**IMPORTANT: When removing spool retainer do not lose shims located between retainer and spool spring guide.**

7. Remove spool assembly and springs (B, C, D, E, F, G, I, and J). If equipped remove feel position assembly (H).
8. Inspect and replace parts as necessary
9. Apply KRYTOX™ GPL202 fluorinated grease to sliding surfaces of adjuster sleeves and push bar top where it contacts the adjusting screw.
10. Install spool assembly and retainer in same bores if using existing parts.
11. Install retainers and (coils if equipped).
12. Install lever housing assembly onto valve housing. Note index marks scribed when disassembly for proper alignment to proper ports. Tighten four allen screws to 8.5 N•m (75 lb-in.)

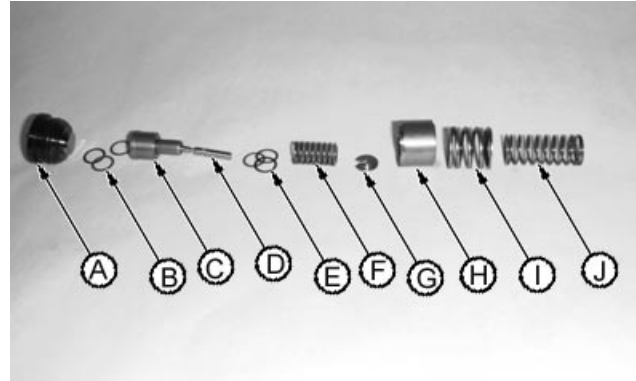

Controller Spool Assembly With Retainer With Feel Position

- A—Retainer (With Seals)
- B—Shims (Spool Positioning)
- C—Guide (Spring)
- D—Spool
- E—Shims (Metering Adjustment)
- F—Spring (Spool)
- G—Retainer Plate (Spool Spring)
- H—Feel Assembly
- I—Spring (Feel Position)
- J—Spring (Return)

**Specification**

Pilot Controller Lever	
Hosing-to-Valve Housing Allen	
Screw—Torque.....	8.5 N•m (75 lb-in.)

KRYTOX is a trademark of E.I. DuPont, DeNemours and Co. Inc.

Continued on next page

TX,31,ME155 -19-04SEP02-21/29

T105763B -UN-19DEC96

31  
3160  
57

## Hydraulic System

1—Grip	16—Plate	31—Seal	46—Feel Position Kit
2—Grip (with quickshift)	17—Nut	32—Backup Ring	47—Spring
3—Hex Nut	18—Bar	33—Retainer	48—Spring
4—Retainer	19—Universal Joint	34—Retainer	49—Housing
5—Tie Band	20—Ball Joint Socket	35—Fitting	50—Weatherpack Nipple
6—Boot	21—Strap	36—Grommet	51—Terminal
7—O-Ring	22—Grommet	37—Plunger	52—Connector
8—Set Screw	23—Cap Screw	38—Plunger	53—Two Lever Controller Assembly
9—Nut	24—Lever Housing	39—Shim (0.4mm / .015 in)	54—Nut
10—Plug	25—Lever Housing	40—Shim (0.2mm / .007 in)	55—Washer
11—Lever	26—Washer	41—Shim (0.1mm / .004 in)	56—Sleeve
12—Nut	27—Tube	42—Spool	57—Universal Joint
13—Washer	28—Coil	43—Spool	58—Spool
14—Adjuster Sleeve	29—Retainer	44—Spool	
15—Lever	30—Stop Ring	45—Spring	

### Disassemble And Assemble

See Pilot Controller Valve (Single Lever Controller), Disassemble and Assemble in this group.

Perform Pilot Control Valve Pressure Test. (See Section 9025-25.)

Perform Pressure Reducing Valve Pressure Test. (See Section 9025-25.)

31  
3160  
67

LS10960,0000029 -19-28OCT02-4/4

### Pilot Controller Repair (Two Lever Controller) (S.N. 585561—)

<b>SERVICE EQUIPMENT AND TOOLS</b>
------------------------------------

JDG1385 STC Fitting Disconnect Tool
-------------------------------------

#### Remove and Install

1. Stop engine.
2. Relieve hydraulic pressure by using boom lever switch and place controller in boom float position.

Continued on next page

LS10960,0000024 -19-04SEP02-1/5

## Remove And Install Ride Control



**CAUTION:** Hydraulic oil may escape at pressure high enough to penetrate skin from components in the Ride Control solenoid circuit if components are removed without discharging the accumulator. Hydraulic oil in accumulator can be stored at pressures equal to or above system relief pressures.

If ride control is **NOT** operational, the ride control accumulator must be discharged by releasing gas charge before starting repair of control valve or any of it's components

If ride control is operational: With boom raised slightly, turn ignition switch to **ON** position. Cycle the ride control switch from **OFF** to **ON** (center position). Boom will jump up unexpectedly if ride control accumulator is energized. Press boom enable switch and move the control lever into the float position and hold for 5 seconds.

1. With boom raised slightly, turn ignition switch to **ON** position. Cycle the ride control switch from **OFF** to **ON** (center position). Boom will jump up unexpectedly if ride control accumulator is energized. Press boom enable switch and move the control lever into the float position and hold for 5 seconds.

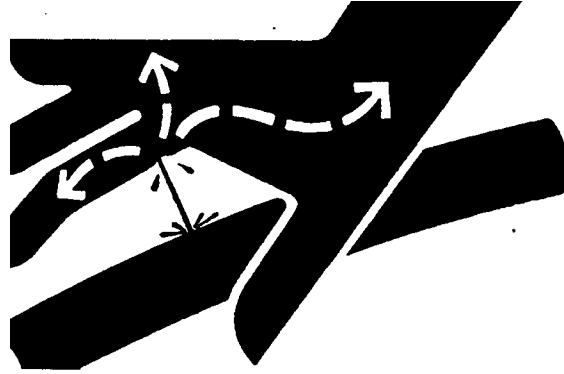

X9811 -UN-23AUG88

31  
3160  
77

Continued on next page

CED,OUOE002,1677 -19-11JUN98-1/2

CLICK HERE TO **DOWNLOAD** THE COMPLETE MANUAL

- Thank you very much for reading the preview of the manual.
- You can download the complete manual from: [www.heydownloads.com](http://www.heydownloads.com) by clicking the link below



- Please note: If there is no response to CLICKING the link, please download this PDF first and then click on it.

CLICK HERE TO **DOWNLOAD** THE COMPLETE MANUAL