

TOYOTA

LAND CRUISER

REPAIR MANUAL

CHASSIS
&
BODY

 TOYOTA MOTOR SALES CO., LTD.

CLICK HERE TO **DOWNLOAD** THE COMPLETE MANUAL

- Thank you very much for reading the preview of the manual.
- You can download the complete manual from: www.heydownloads.com by clicking the link below



- Please note: If there is no response to CLICKING the link, please download this PDF first and then click on it.

CLICK HERE TO **DOWNLOAD** THE COMPLETE MANUAL

Fig. 2-1

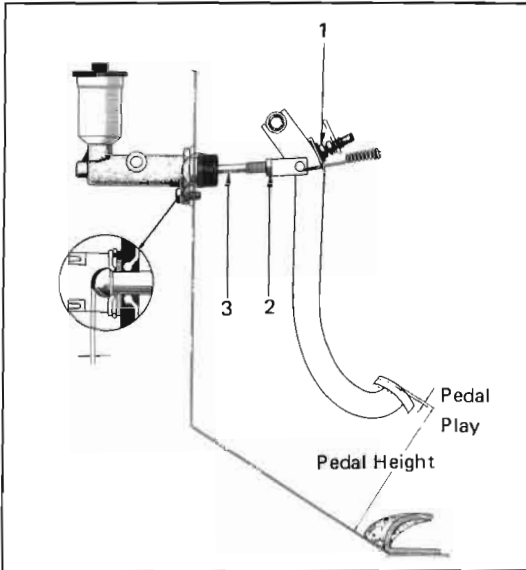

Fig. 2-2

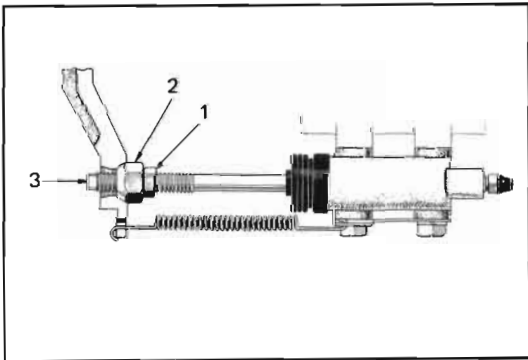
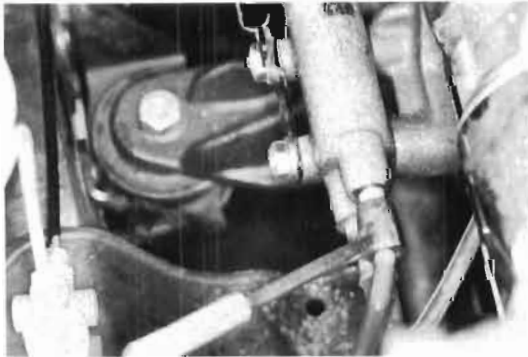

Fig. 2-3



4. Depress the clutch pedal several times, and then while holding it depressed, loosen the bleeder plug about one-third to one-half turn. When the fluid pressure in the cylinder is almost depleted retighten the plug. Repeat this operation until there are no more air bubbles in the system.

ADJUSTMENT

CLUTCH PEDAL

1. Loosen the lock nut (2) and the push rod (3).
2. Adjust the pedal height by turning the stop bolt (1).

Standard pedal height

	w/brake booster mm (in.)	w/o brake booster mm (in.)
FJ, HJ, BJ40 series	215 (8.46)	198 (7.86)
FJ55 series	185 (7.28)	172 (6.77)

(From asphalt sheet top surface)

3. Adjust the pedal play by loosening the lock nut (2) and turning the push rod (3).

Pedal play 0.5-3.0 mm (0.02-0.12 in.) at pedal top

RELEASE CYLINDER

Adjust the play at release fork tip by loosening the lock nut (1), and turning the push rod (3) tip with a spanner while holding the push rod nut (2) with a wrench.

Fork tip play FJ, HJ series 3-4 mm

(0.12-0.16 in.)

BJ series 2-3.5 mm

(0.08-0.14 in.)

BLEEDING CLUTCH SYSTEM

If any work is performed on the clutch system or if any air enters in the clutch line, remove the air by bleeding the system.

– Caution –

1. When bleeding make certain that the brake fluid in the master cylinder reservoir does not become empty.
2. Do not allow brake fluid to remain on painted surfaces.
 1. Jack up the car and support it on stands.
 2. Fill the master cylinder reservoir.
 3. Attach a vinyl tube to the release cylinder bleeder plug, and insert the other end of tube into a container.
5. When the bubbles stop, depress and hold the clutch pedal and tighten the bleeder plug.
6. After completing the bleeding operation, apply fluid pressure on the pipe line and check for leakage.
7. Replenish the fluid in the reservoir to the specified level.

Fig. 2-30

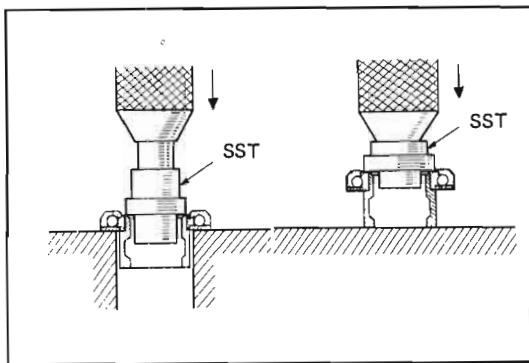
**Release Bearing Replacement**

1. Using SST [09315-00021], remove the bearing.



2. Using SST [09315-00021], install the bearing.

Fig. 2-31

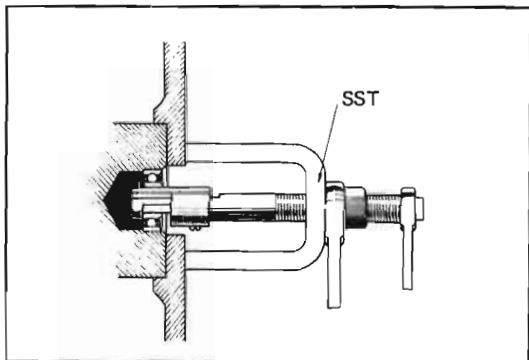
**Pilot Bearing**

With the bearing still installed on the crankshaft, inspect it for excessive wear, sticking, and abnormal noise.

Replace the bearing if found defective.

1. Using SST [09303-55010 . . . FJ & HJ series, 09303-35010 . . . BJ series], remove the bearing from the crankshaft.

Fig. 2-32

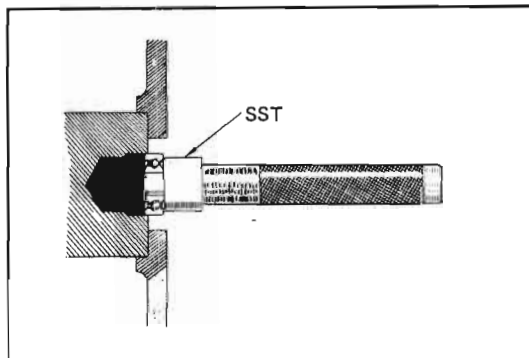

2. Coat the new bearing with multipurpose grease, and using SST [09304-47010 . . . FJ & HJ series, 09304-30012 . . . BJ series], drive the bearing into the crankshaft.

ASSEMBLY

[FJ & HJ Series]

Perform the disassembly in reverse order.

– Note –

1. Coat multipurpose grease on the sliding surfaces of all parts to be assembled.
2. Make sure to align the mating marks when assembling the pressure plate to the clutch cover.
3. When assembling the clutch cover to pressure plate in the HJ series, use a press in the same manner as during disassembly.

Fig. 3-10



Remove the back up light switch
– Caution –
Back up light switch must always be removed before taking off the transfer assembly.

Fig. 3-11

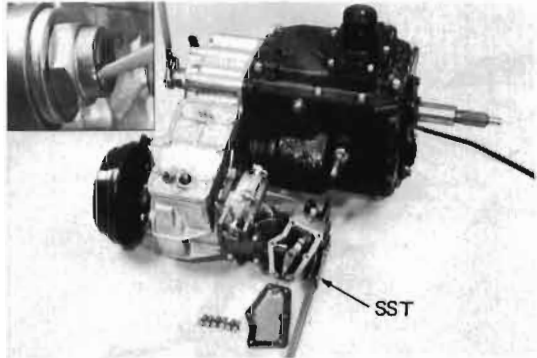

Loosen the staked parts of the nuts.
Use SST [09330-00020] to hold the companion flange from turning, and remove the nut.
– Note –
Have the front drive engaged.

Fig. 3-12

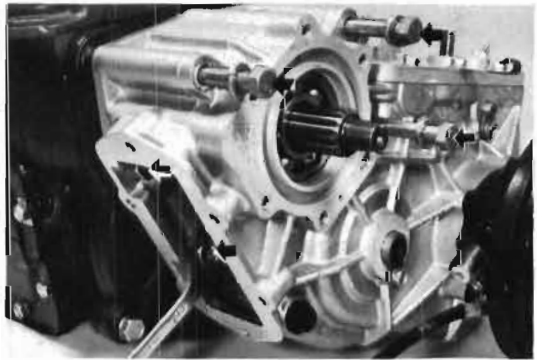

Remove the five bolts.

Fig. 3-13

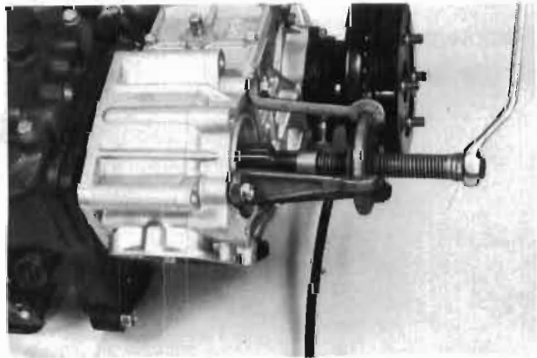

Using a puller, separate the transfer assembly.
– Caution –
When pulling the transfer case away from the transmission, hold on to the power take-off gear to prevent it from dropping out of the case.

Fig. 3-35

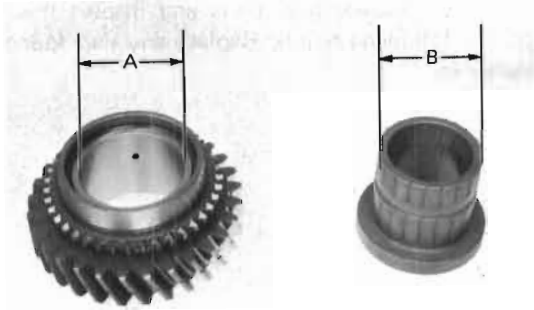

3. **Third gear oil clearance (A – B)**
Limit 0.12 mm (0.0047 in.)
Standard 0.07 – 0.12 mm
 (0.0028 – 0.0047 in.)

Fig. 3-36



Synchronizer Ring

Fit the synchronizer ring on the gear and measure the clearance.

Third and fourth gear synchronizer ring clearances

Limit 0.8 mm (0.031 in.)

Fig. 3-37

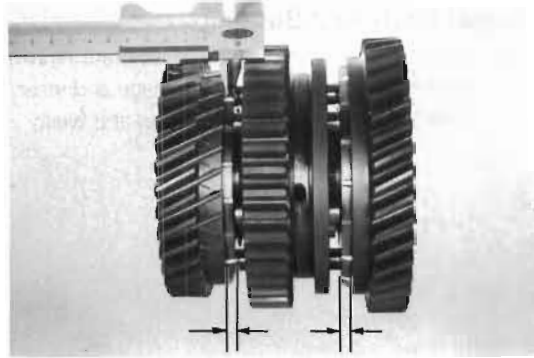

Synchronizer Ring No.1 Dimensions

Second gear limit 1.8 mm (0.071 in.)

First gear limit 2.8 mm (0.110 in.)

Fig. 3-38



Clutch Hub Sleeve, Clutch Hub, Shifting Keys, And Shifting Key Springs

1. Disassemble the clutch hub and sleeve.
2. Inspect the splines of hub and hub sleeve for damage and wear.
3. Inspect the center humped part of keys for damage and wear.
4. Inspect the key springs for weakening and damage.

Fig. 3-63

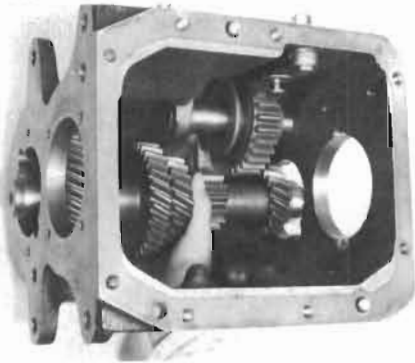

Lay the countershaft on the bottom of transmission case.

Fig. 3-64

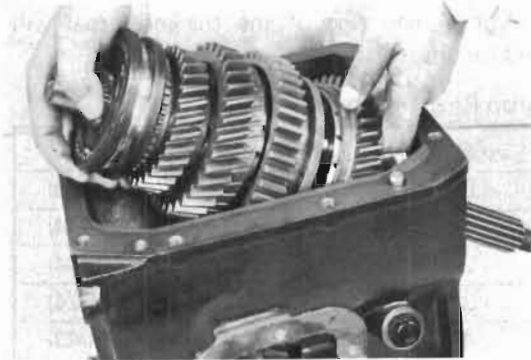

Install The Output Shaft Assembly

1. Insert the output shaft assembly into the case.

Fig. 3-65

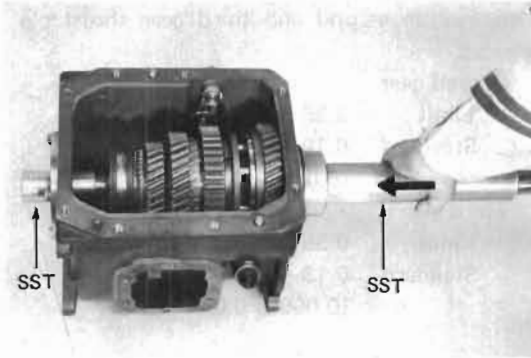

2. Mount SST[09314-36010].
3. Using SST[09309-36020], drive in the bearing.
4. Remove SST[09314-36010].

Fug. 3-66



Install The Input Shaft, Bearing, And Ring.

1. Apply grease to the input shaft and assemble in the 17 bearing rollers.

Fig. 3-86

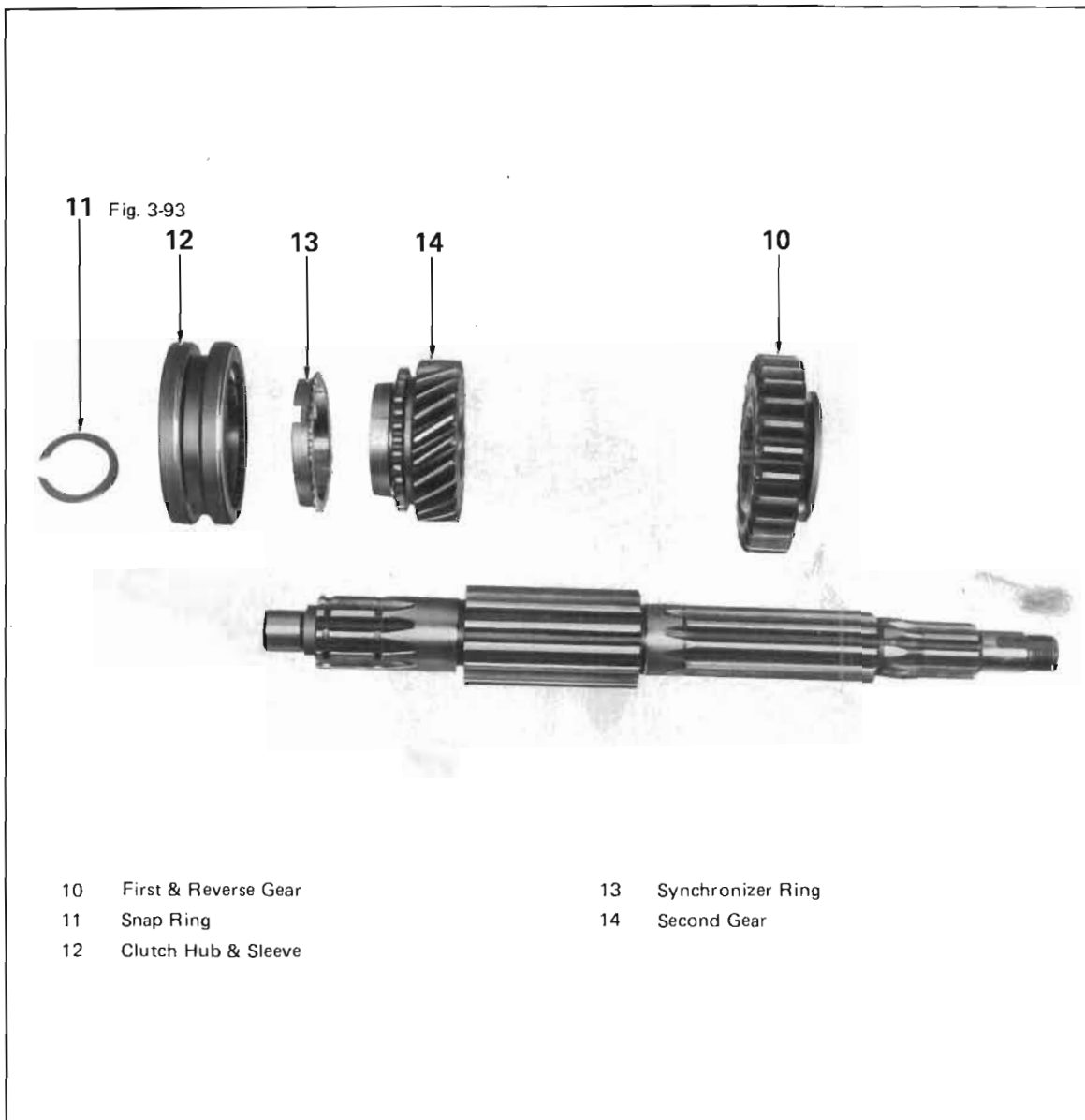

Fig. 3-87



Drive out the shaft toward the front.

– Caution –

Cover the locking ball hole with finger so as to prevent the locking ball from jumping out.

Fig. 3-118

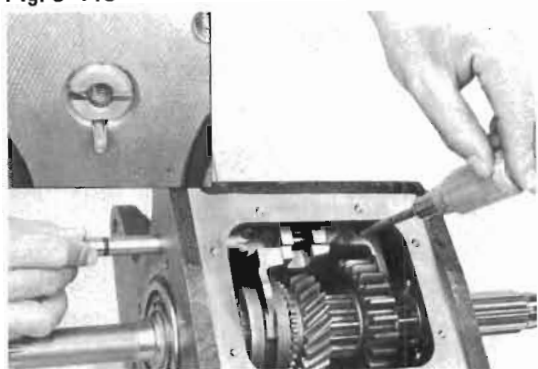

While holding down the locking ball, drive in the shaft, and then lock the shaft with straight pin.

Fig. 3-119

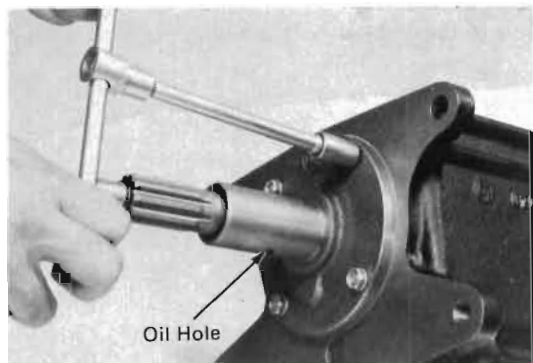

Install the retainer with its oil hole positioned downward.

Fig. 3-141



Gears

Inspect the teeth, thrust faces, inside diameter surfaces, and coned parts for damage and wear.

Fig. 3-142

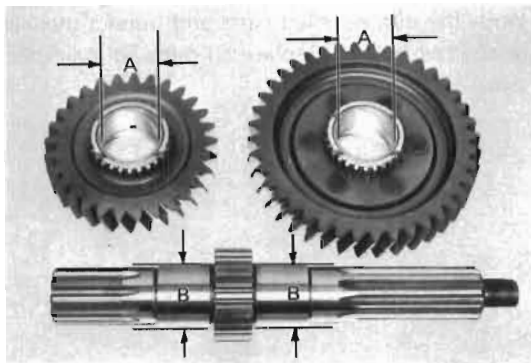

Oil Clearance (A – B)

High and low speed output gears

Limit 0.09 mm (0.004 in.)

Standard 0.035 – 0.081 mm

(0.00138 – 0.00319 in.)

Fig. 3-143



Bearings

Inspect for damage and wear.

Fig. 3-144

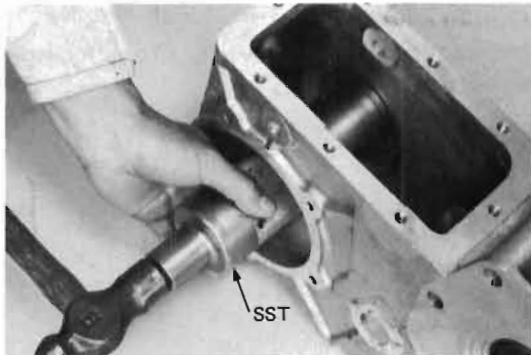

Bearing Race Replacement

1. Using SST[09316-60010], drive out the outer race.

PROPELLER SHAFT

	page
PROPELLER SHAFT	4-2

INSTALLATION

Install the parts in the order numbered in figure.

Fig. 5-10

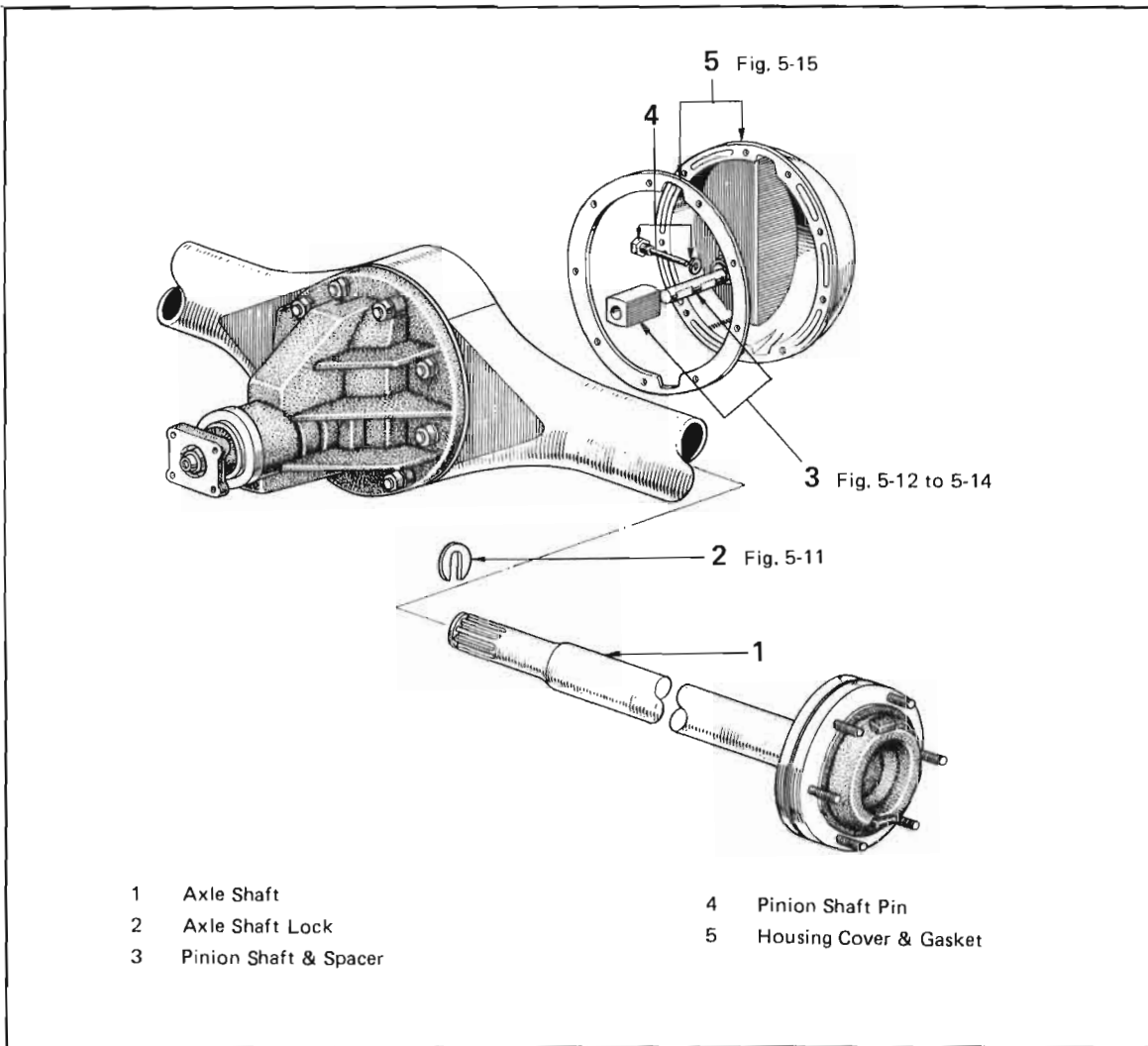
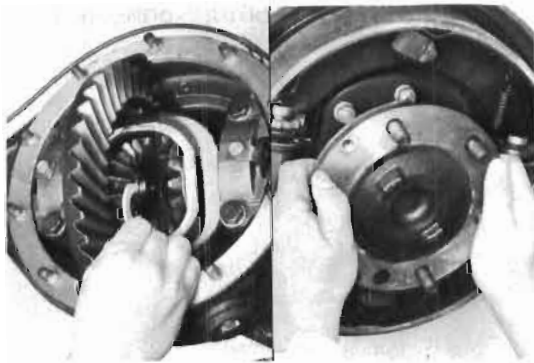

Fig. 5-11



After installing the lock to the shaft, pull the shaft fully toward the outer side of vehicle.

DIFFERENTIAL

REMOVAL

After draining out the oil, remove the parts in the order numbered below.

Fig. 5-35

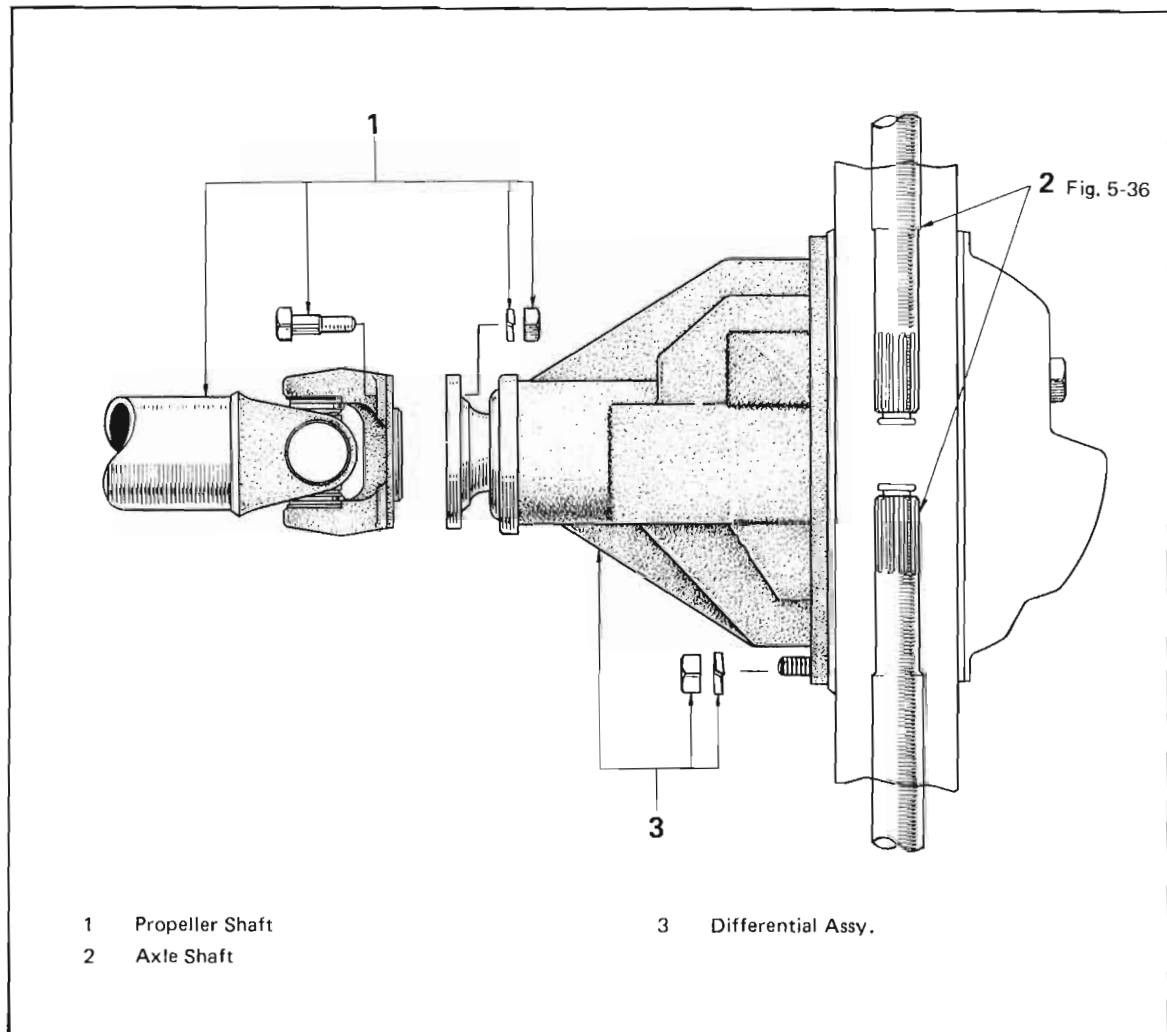
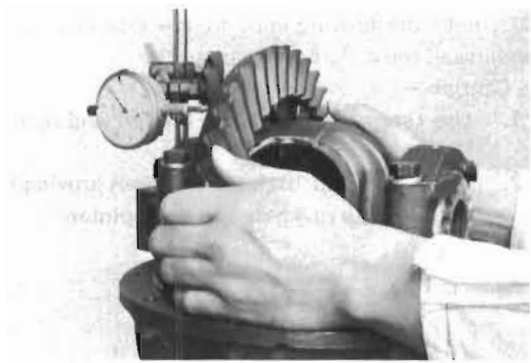

Fig. 5-36

SEE
REAR AXLE SHAFT
SECTION

Remove the axle shafts.

Fig. 5-64



3. Mount a dial gauge to the carrier with the plunger set on the rear face of ring gear.
4. Tighten the adjusting nut until side play is removed, and from this zero-play position, tighten the adjusting nut further one to two notches.
5. Tighten the bearing caps at the specified torque.

**Tightening torque 9.0 – 11 kg-m
(65.1 – 79.6 ft-lb)**

Fig. 5-65



6. Measure the overall preload.
**Specified preload (starting)
(For both new and old bearing)
4 – 6 kg-cm (3.5 – 5.2 in-lb)
+ Drive pinion preload**

Fig. 5-66

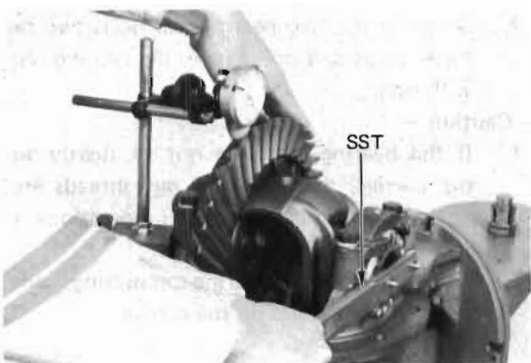

Backlash adjustment

1. Loosen the bolts installing the left and right bearing caps until the spring washers are loosely compressed.
2. Adjust the backlash to the specified value by using SST [09504-00010] and turning the left and right adjusting nuts by equal amounts (such as loosening the left side one notch and tightening the right side one notch).

**Specified backlash 0.15 – 0.20 mm
(0.0059 – 0.0079 in.)**

Fig. 5-67



3. Tighten the bearing cap bolts at the specified torque.

**Tightening torque 9.0 – 11 kg-m
(65.1 – 79.6 ft-lb)**

Fig. 6-14

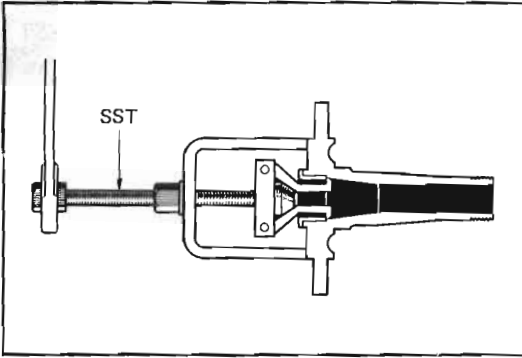

2. Bushing replacement
 - a. Remove the bushing with SST[09612-65012].

Fig. 6-15

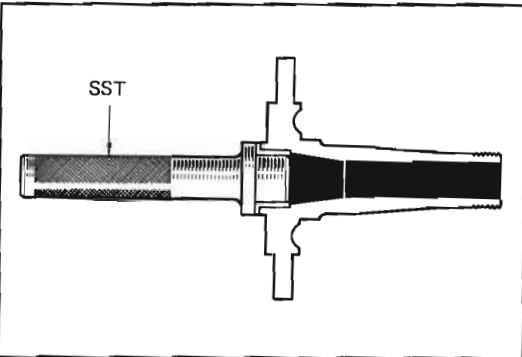

- b. Install the new bushing with SST [09618-60010].

Fig. 6-16



Steering Knuckle Bearing

1. Inspect for wear, damage, and rusting.

BEARING 4T30303D

Fig. 6-17

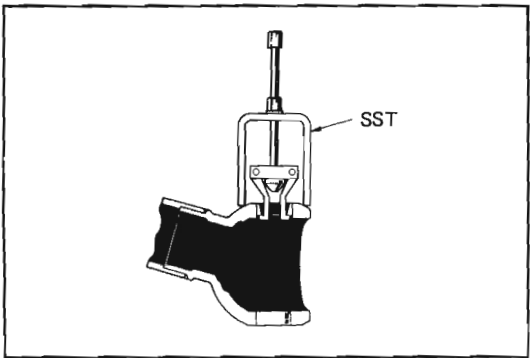

2. Outer race replacement
 - a. Remove the bearing outer race with SST [09612-65012].

Fig. 6-47

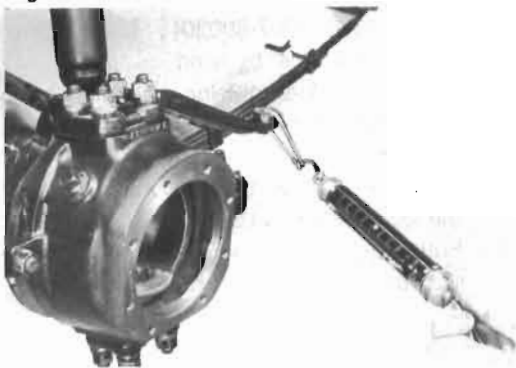

1. Measure the knuckle bearing preload.
Specified pull 1.8 – 2.3 kg
(3.9 – 5.0 lb)

2. Install the tie rod end to the knuckle arm.

– Caution –

If the specified pull is not indicated, correct by varying the number of upper and lower adjusting shims by equal amounts.

Fig. 6-48



Position the flat part of the outer shaft in vertical direction and install the drive shaft assembly.

– Caution –

1. Use care not to damage the oil seal lip.
2. Pack Molybdenum disulphide lithium base grease into the knuckle to about three-fourth of the knuckle volume.

Fig. 6-49

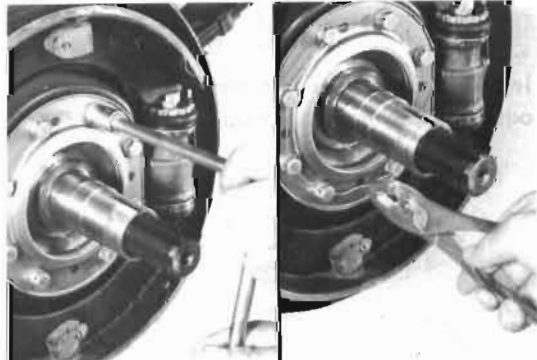

Install the nuts and lock them with the lock wire.

Tightening torque 1.5 – 2.2 kg-m
(10.9 – 16.0 ft-lb)

Fig. 6-50



Pack multipurpose grease into the hub and bearing.

Apply multipurpose grease to the oil seal lip.

INSTALLATION

Install the parts in the order shown below.

Fig. 6-78

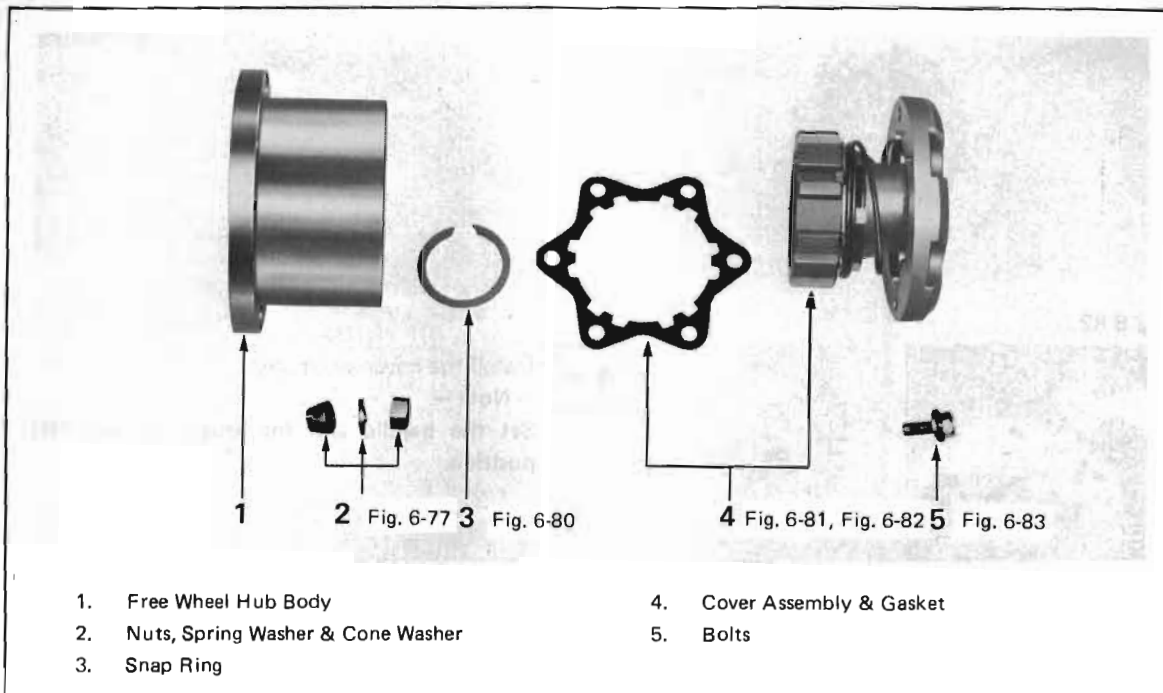
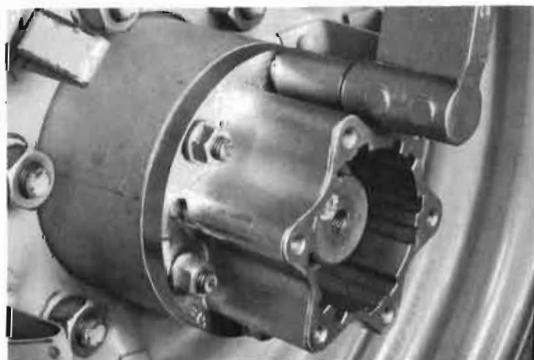

Fig. 6-79



Tighten six nuts to the specified torque.
Tightening torque 2.5 – 3.5 kg-m
 (18.1 – 25.3 ft-lb)

Fig. 6-80



Use SST [09905-00010].
 — Note —
 Gripping a bolt, pull the axle shaft out to install the snap ring.

ASSEMBLY

Assemble the parts in the order numbered below.

Fig. 7-13

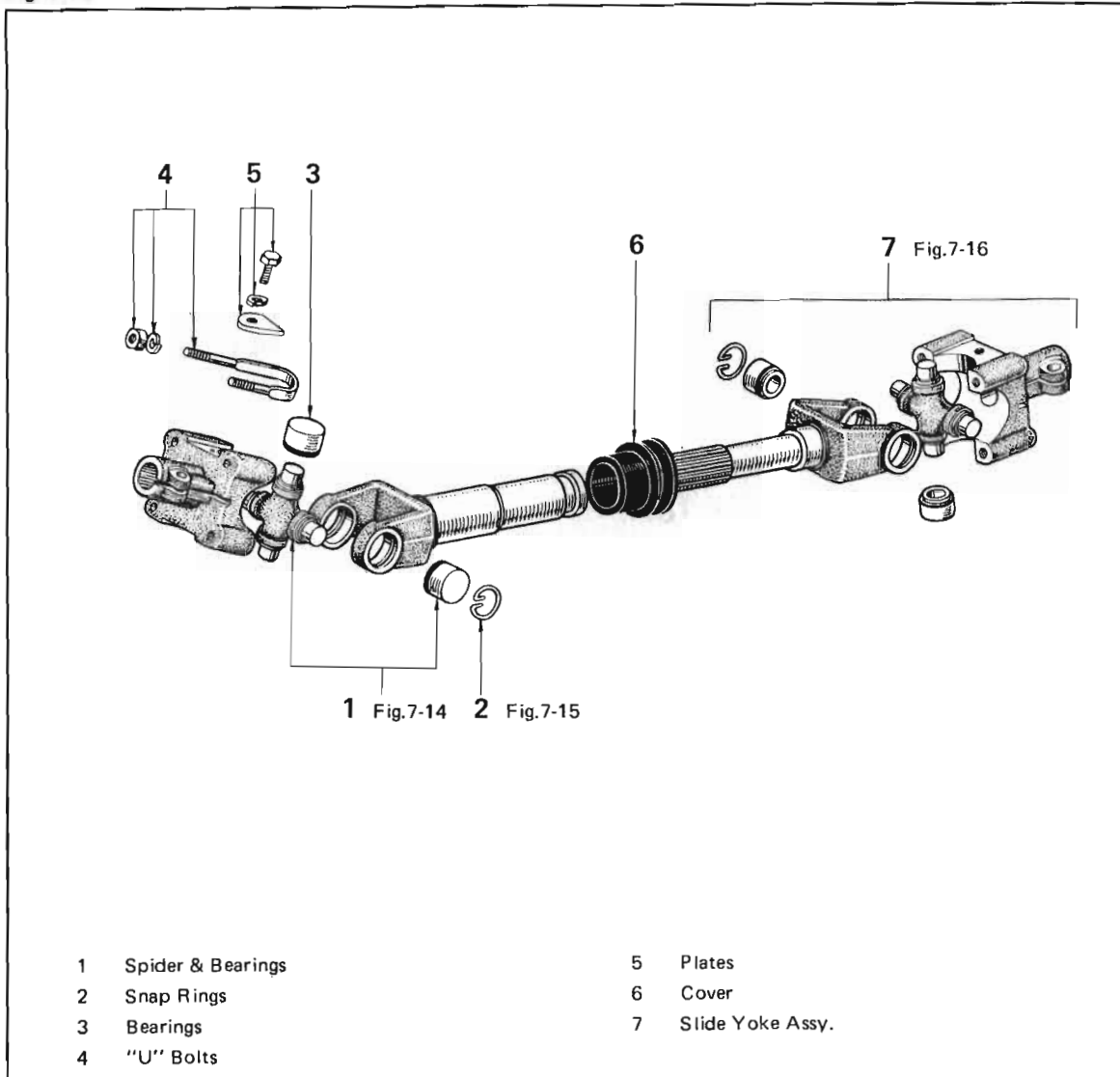
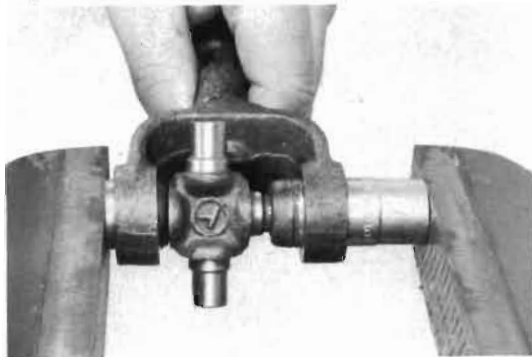

Fig. 7-14



Using a vise, assemble the bearings.

ASSEMBLY

Assemble the parts in the order numbered below.

Fig. 7-39

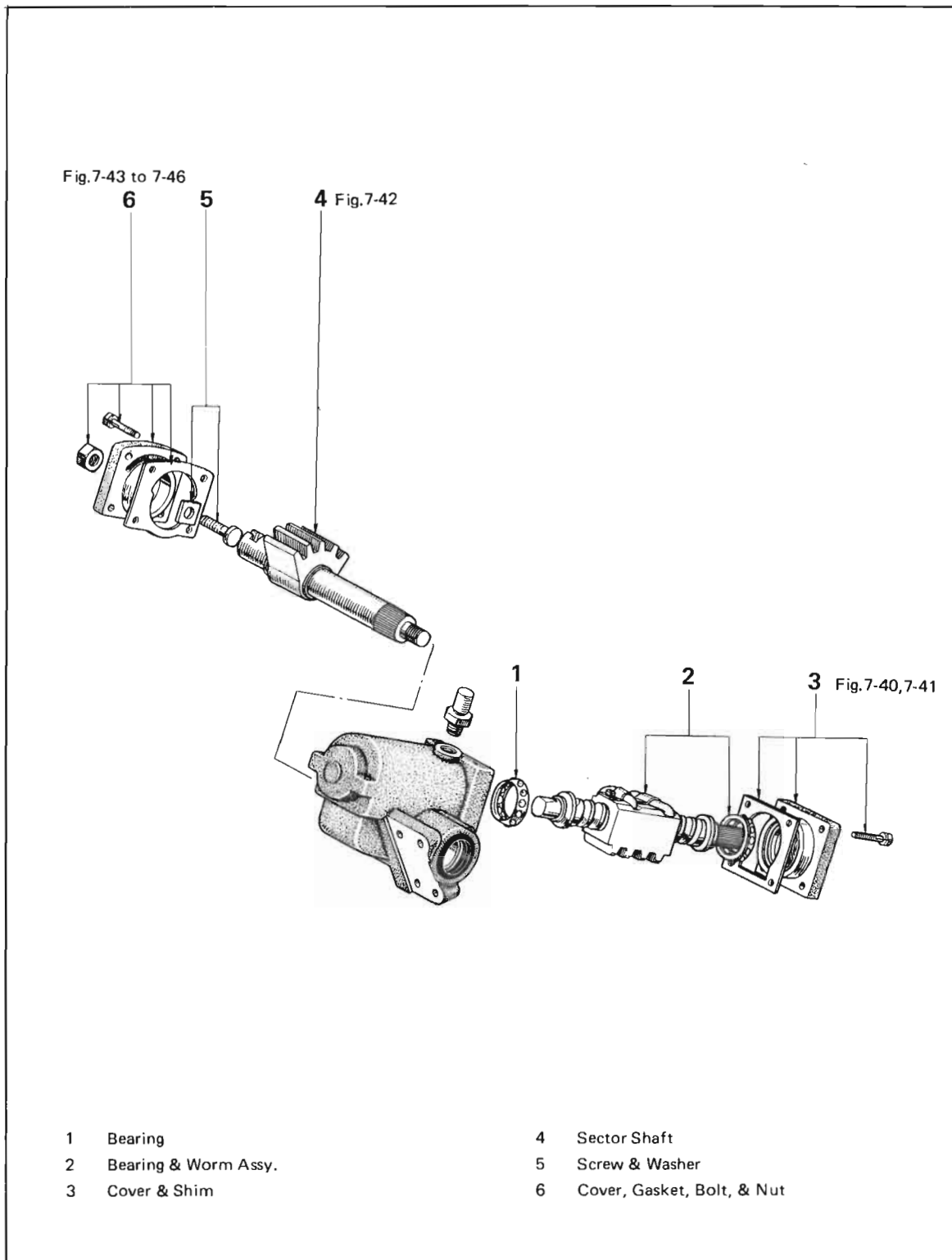

FRONT WHEEL ALIGNMENT

Fig. 7-64

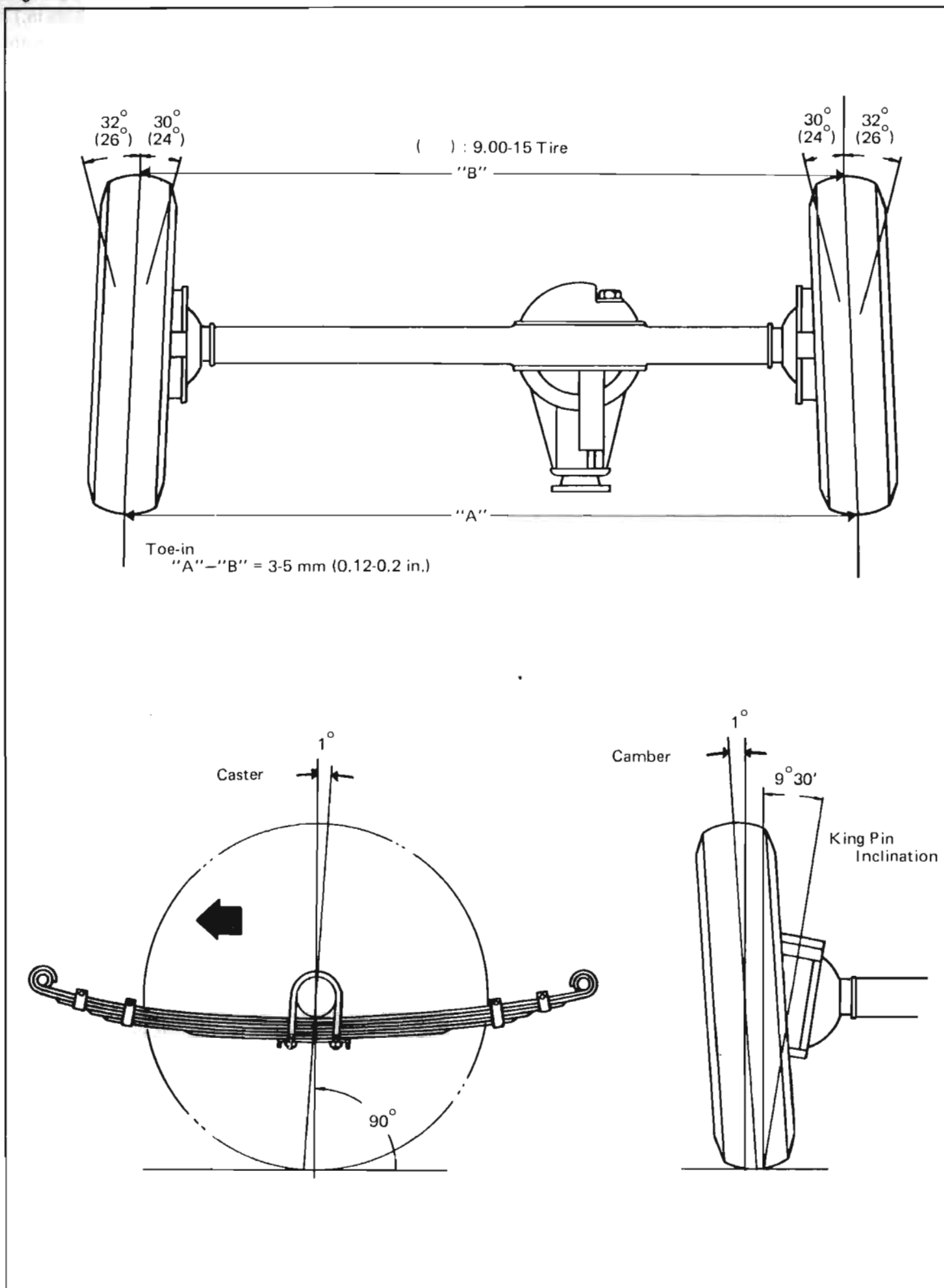

ASSEMBLY

Assemble the parts in the order numbered below.

Fig. 8-15

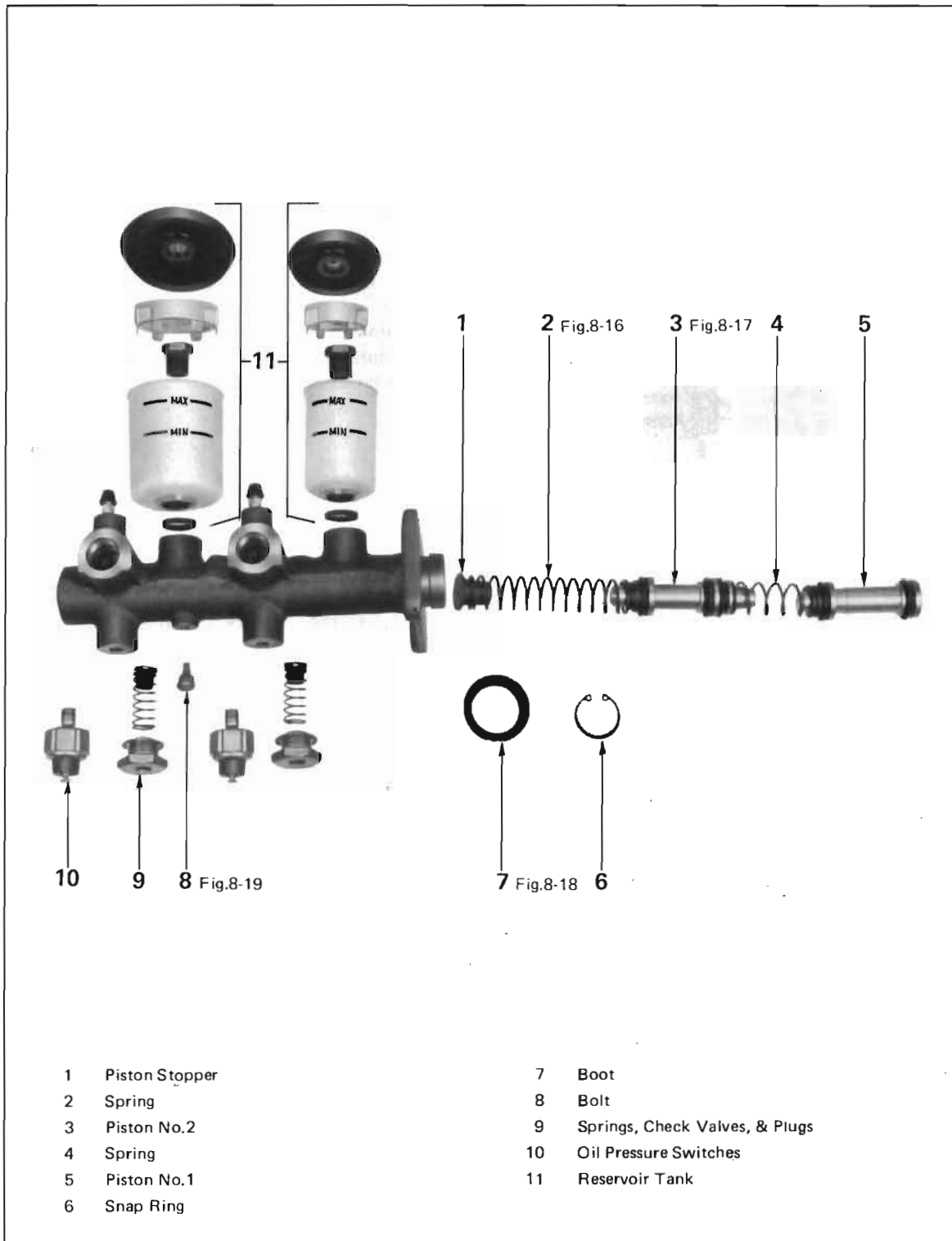

- | | | | |
|---|----------------|----|--------------------------------|
| 1 | Piston Stopper | 7 | Boot |
| 2 | Spring | 8 | Bolt |
| 3 | Piston No.2 | 9 | Springs, Check Valves, & Plugs |
| 4 | Spring | 10 | Oil Pressure Switches |
| 5 | Piston No.1 | 11 | Reservoir Tank |
| 6 | Snap Ring | | |

CLICK HERE TO **DOWNLOAD** THE COMPLETE MANUAL

- Thank you very much for reading the preview of the manual.
- You can download the complete manual from: www.heydownloads.com by clicking the link below



- Please note: If there is no response to CLICKING the link, please download this PDF first and then click on it.

CLICK HERE TO **DOWNLOAD** THE COMPLETE MANUAL

Fig. 8-40

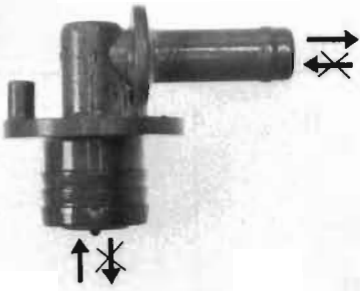

Vacuum Check Valve

Check the operation of valve.

Fig. 8-64

**Diaphragm**

Inspect for damage.

Fig. 8-65

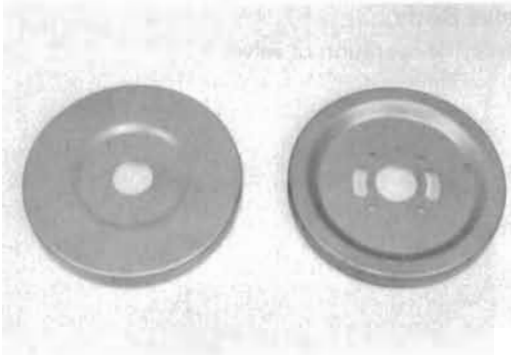
**Diaphragm Plate**

Inspect for cracks or damage.

Fig. 8-66

**Center Plate And Seal**

Inspect for cracks or damage.

Fig. 8-67

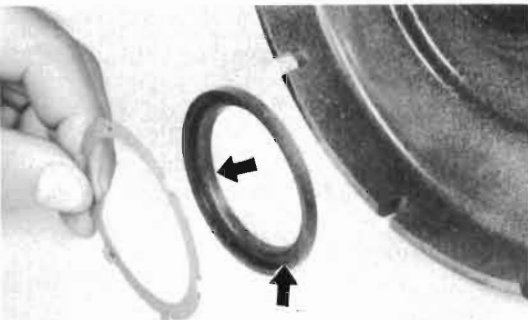

Apply silicon grease to the face indicated, and install the seal in the center plate.

Fig. 8-92



Drive out the pins from the casing until flush with the inner face of end frame, and remove the end frame with the pins attached.

Fig. 8-93



INSPECTION



Inspect the disassembled parts on the following points, and replace all parts found defective.

End Cover And Casing

Inspect for damage and wear.

Casing bore wear limit 58.19 mm (2.291 in.)

Fig. 8-94

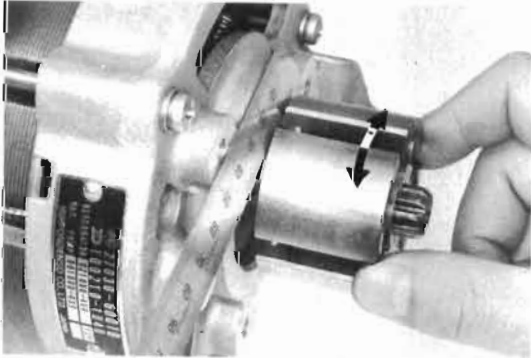

Alternator Shaft And Rotor

Check the rotor-to-spline play

Limit (on rotor) 2.4 mm (0.095 in.)

Fig. 8-95

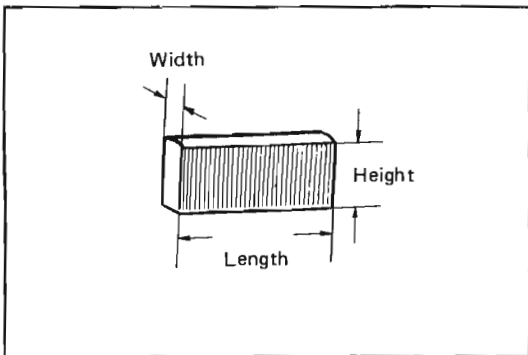

Blades

Inspect for damage and wear.



Height limit	mm (in.)	12 (0.47)
Width limit	mm (in.)	0.92 (0.272)
Length limit	mm (in.)	34.98 (1.377)

FRONT BRAKE(DISC TYPE)

REMOVAL

Remove the parts in the order shown below.

Fig. 8-119

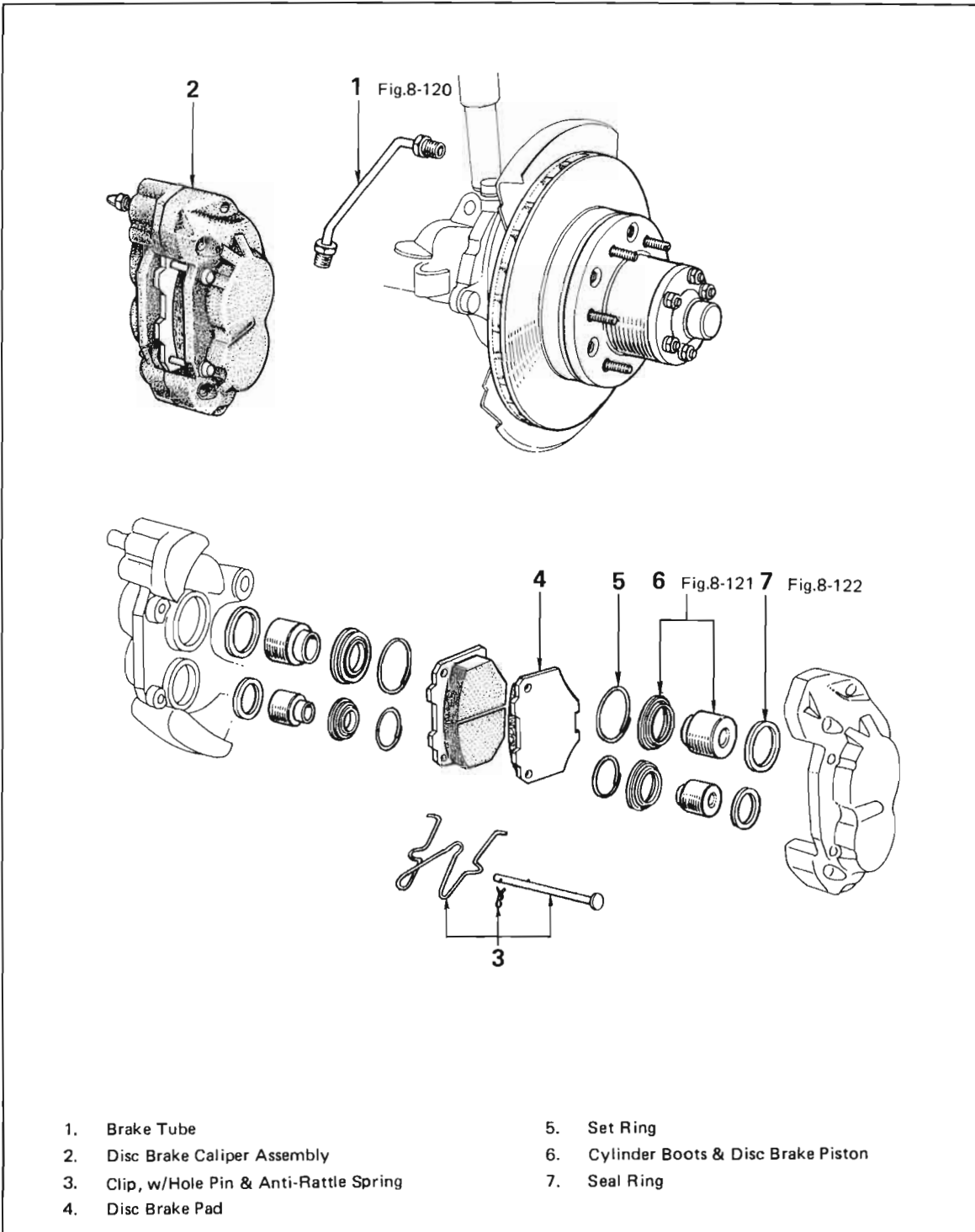

- | | |
|--|---------------------------------------|
| 1. Brake Tube | 5. Set Ring |
| 2. Disc Brake Caliper Assembly | 6. Cylinder Boots & Disc Brake Piston |
| 3. Clip, w/Hole Pin & Anti-Rattle Spring | 7. Seal Ring |
| 4. Disc Brake Pad | |

Fig. 8-144

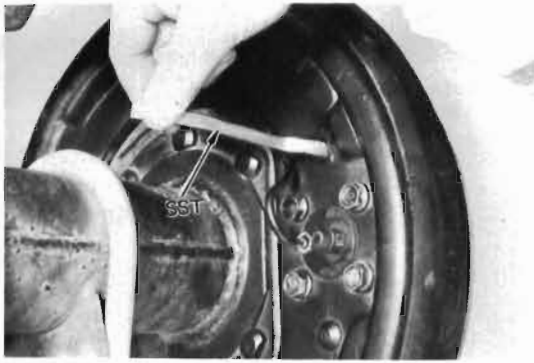

Return the wheel cylinder adjusting nut with SST [09704-10010] and then remove the drum.

Fig. 8-145

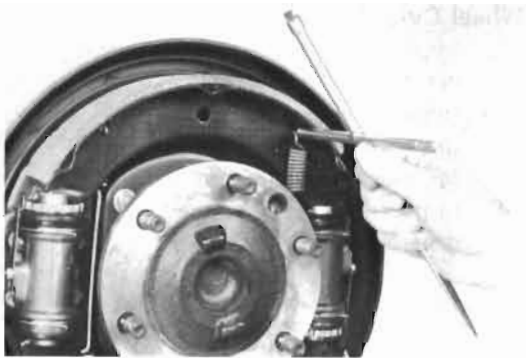

Remove with SST [09703-30010].

Fig. 8-146

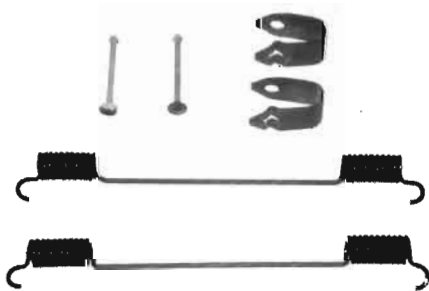

INSPECTION

Inspect the disassembled parts on the following points and replace all defective parts found.

Springs And Pins

Inspect for damage and deformation.

Fig. 8-147



Shoes And Linings

Inspect for wear, damage, and deformation.



Lining thickness limit 1.5 mm (0.06 in.)

FRONT WINCH

	page
CUTAWAY VIEW	9- 2
POWER TAKE-OFF	9- 3
WINCH	9-10

Fig. 9-20

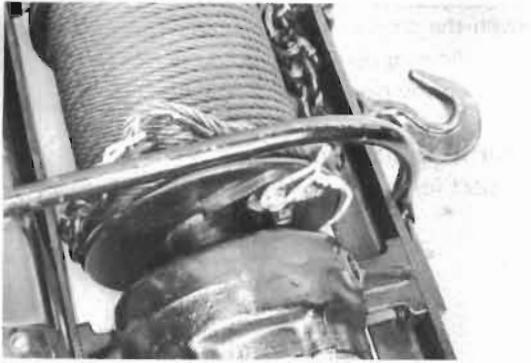

Keep the wire rope end tied together with a wire as shown in the photo.

Fig. 9-21



Remove the front and rear base members, and the roller bracket supports.

Fig. 9-22



Remove the winch end bracket assembly.

BODY

	page
FJ55 SERIES	
HOOD.....	11- 2
FRONT DOOR	11- 4
REAR DOOR	11- 8
WINDSHIELD	11-10
TAIL GATE.....	11-14
ROOF HEADLINING	11-23
FJ40 SERIES	
HOOD.....	11-27
DOOR.....	11-28
BACK DOOR	11-33

Fig. 11-27

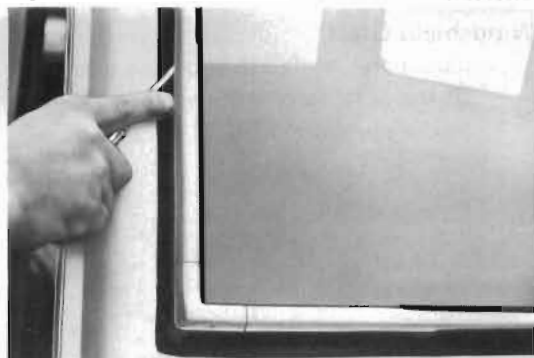

1. Remove the moulding with a screwdriver or similar tool.

Fig. 11-28



2. Using a screwdriver, remove the adhesive attaching the weatherstrip to the body.

Fig. 11-29

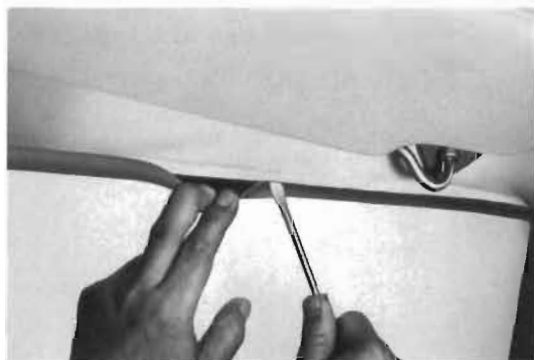

3. From inside the car, push out the weatherstrip upper side toward the outside with a screwdriver.

Fig. 11-30



4. Push the glass surface near the upper side of the weatherstrip toward the outside, and remove the glass with the weatherstrip attached.

– Note –

Apply force uniformly on the glass when pushing it out.

Fig. 11-60

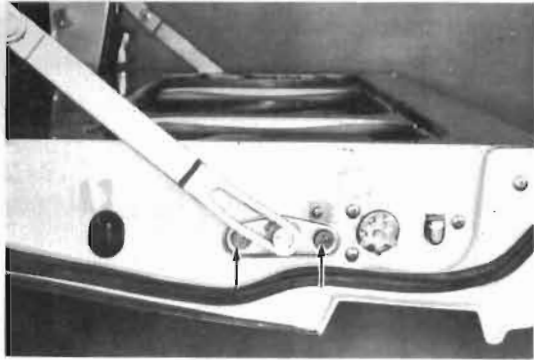

7. Remove the tail gate support stay from the tail gate, and take off the tail gate.

Fig. 11-61



8. Remove the hinges from the body.

Fig. 11-62



9. Remove the torsion cover (1), and pull out the torsion bar (2).

Fig. 11-63



Installation

Install by performing the removal in reverse order.

— Note —

When attaching the tail gate to the hinges, insert a wood piece between the torsion bar and body.

Fig. 11-90

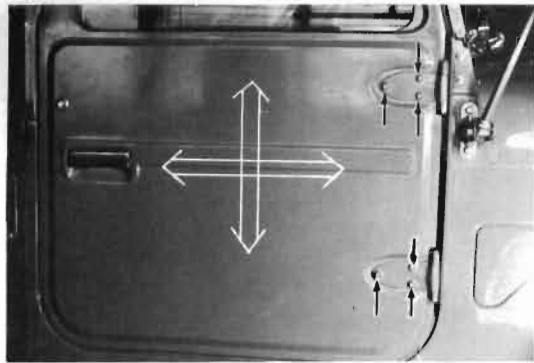

Fig. 11-91

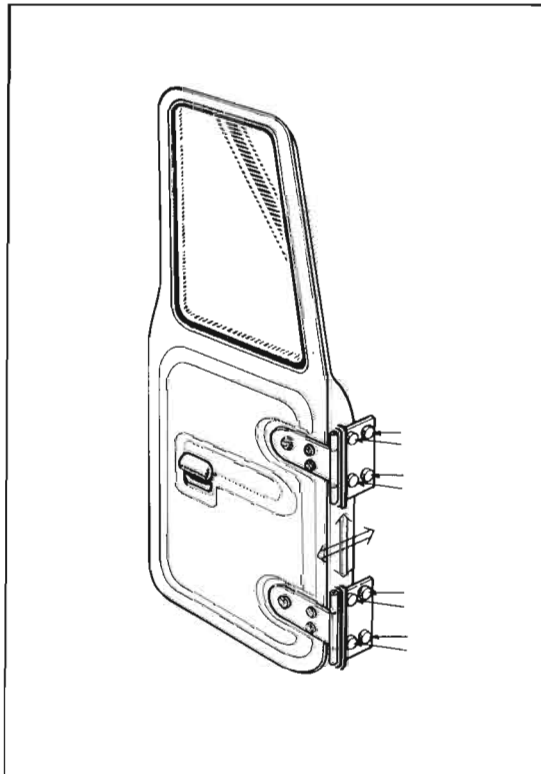
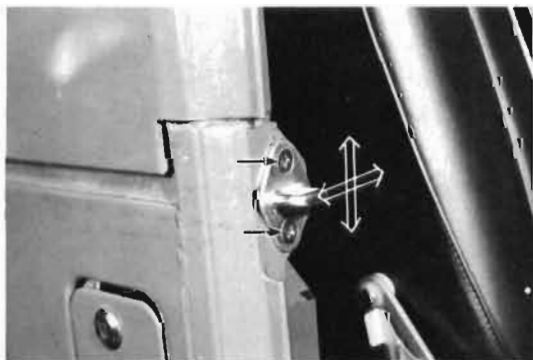

Fig. 11-92



ADJUSTMENT

Door

1. Adjust the door in front-rear and vertical directions by loosening the door hinges at the door.

2. Adjust the surface difference with fender and in vertical direction by loosening the door hinges at the body.

3. Correct improper door closure by adjusting the door lock striker.

HEADLIGHT & TAIL LIGHT

Fig. 12-10

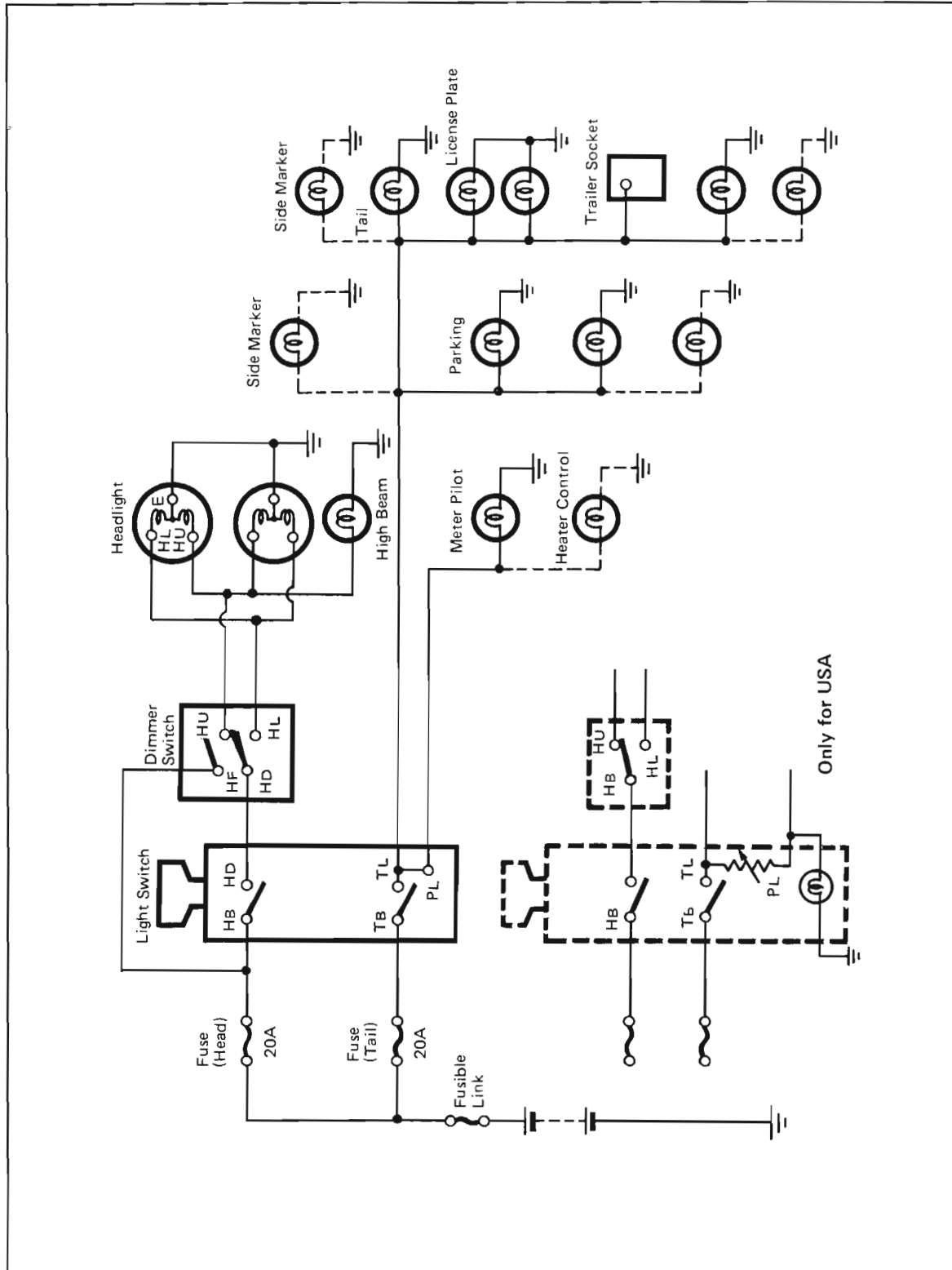
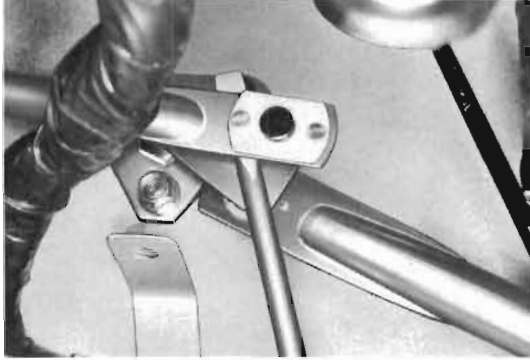

Fig. 12-30



(2) Take out the pivot.

Fig. 12-31



4. Wiper link removal

(1) Disconnect the wiper link and pivot.

Fig. 12-32

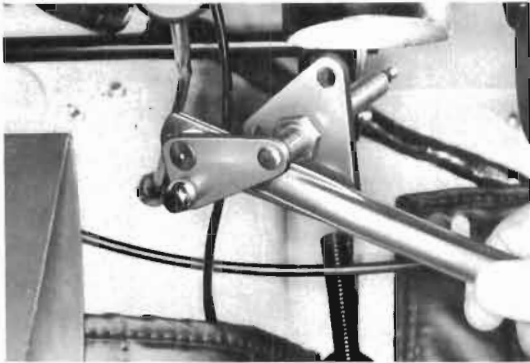

(2) Remove the three bolts attaching the pivot, and take off the wiper link.

Fig. 12-33

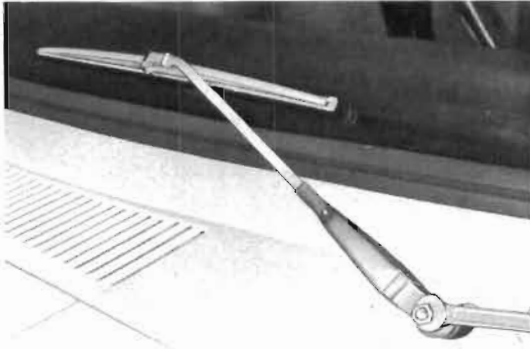

INSTALLATION

Perform the removal in reverse order.

– Note –

Install the wiper blades after installing the wiper motor and verifying the auto stop position.

FUEL GAUGE & WATER TEMPERATURE GAUGE

INSPECTION

Fig. 12-53

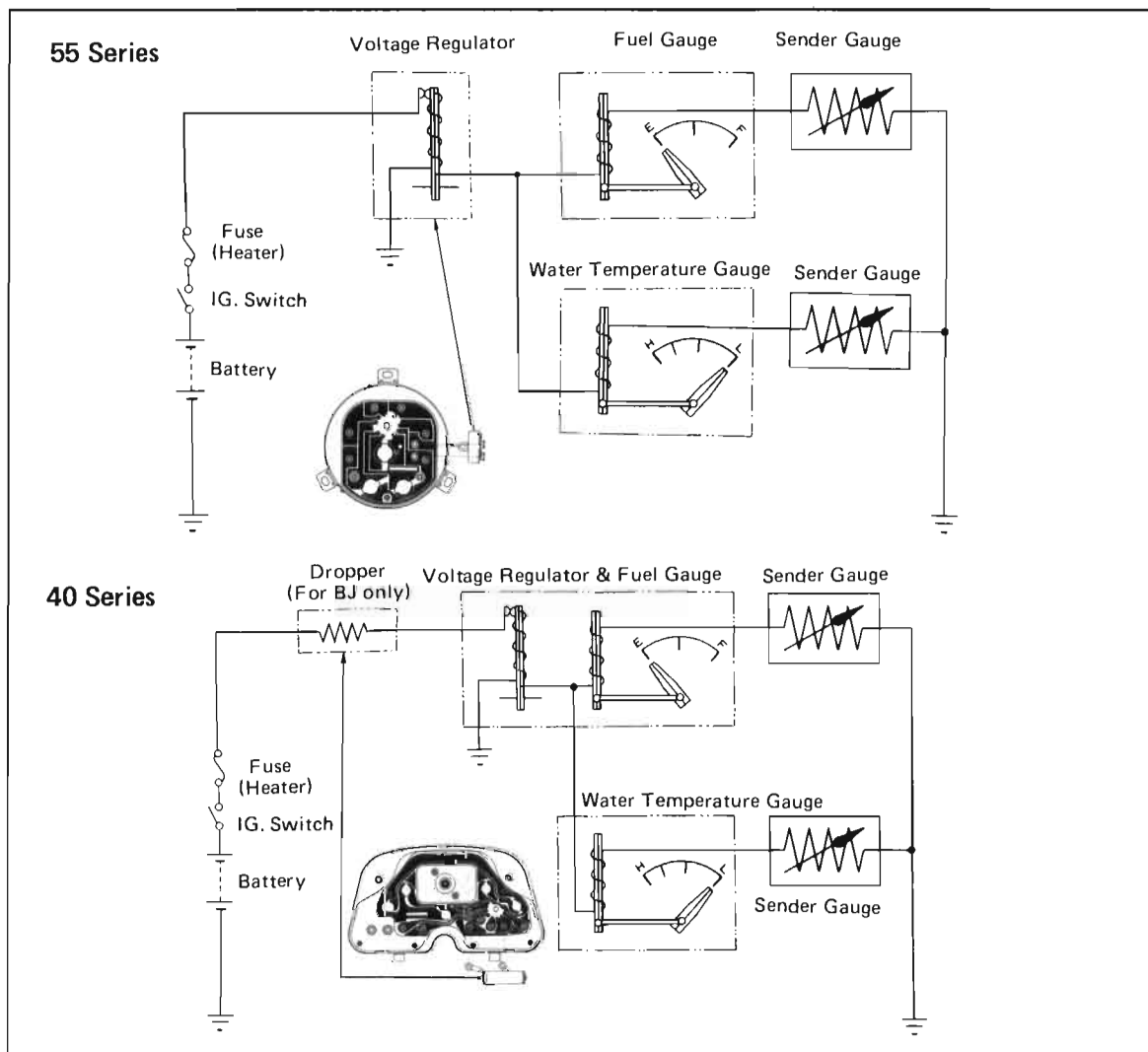
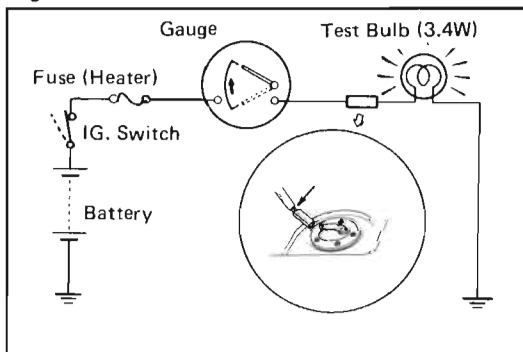

Fig. 12-54



Fuel Receiver Gauge

1. Pull out the connector from the fuel sender gauge and ground the terminal through a 3.4W bulb. When the ignition switch is turned on, the bulb should light (but start to flash after few seconds) and the gauge pointer should deflect, if the gauge is in proper condition.

Fig. 12-77

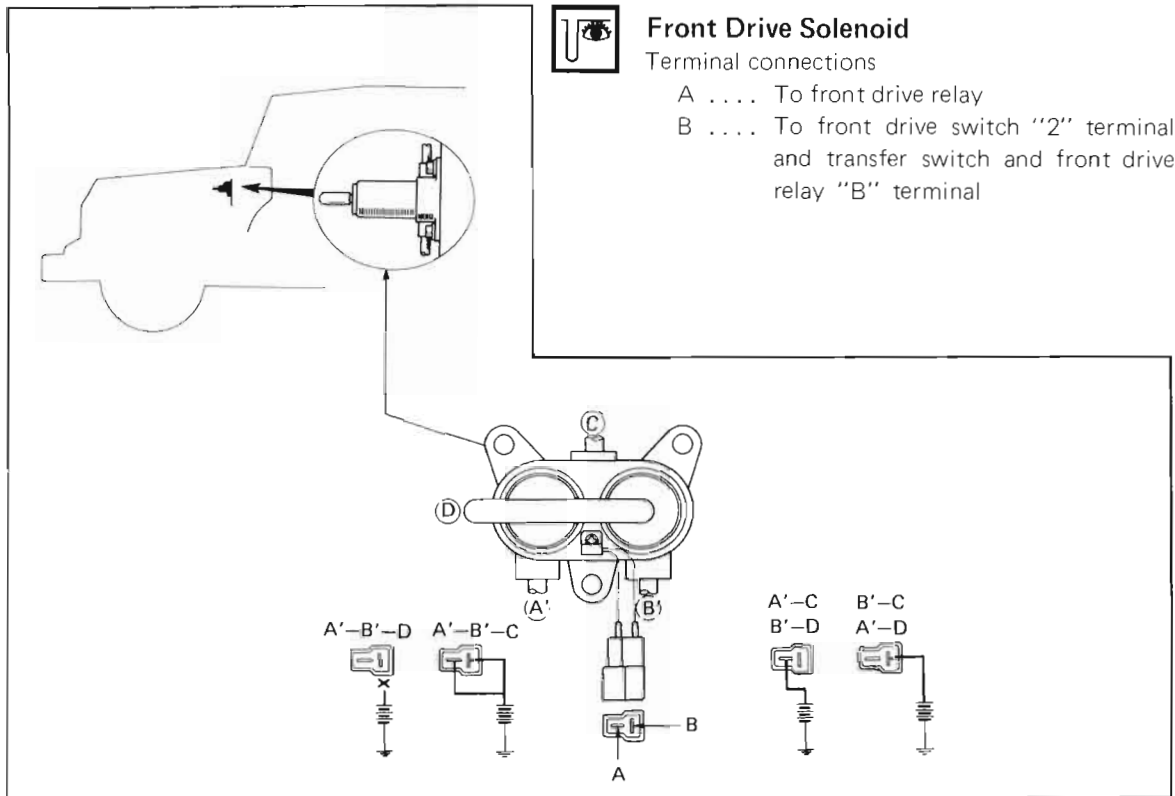
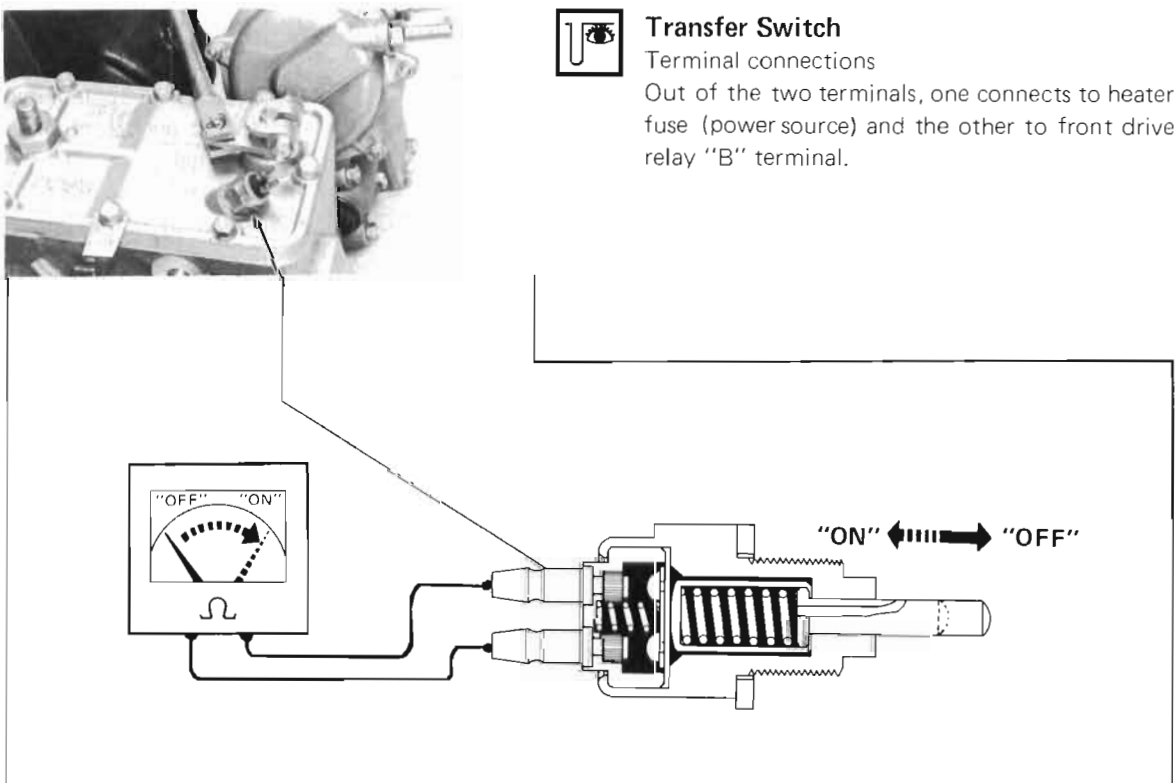

Fig. 12-78



HEATER RADIATOR

Removal

Remove the parts in the order numbered below.

Fig. 12-99

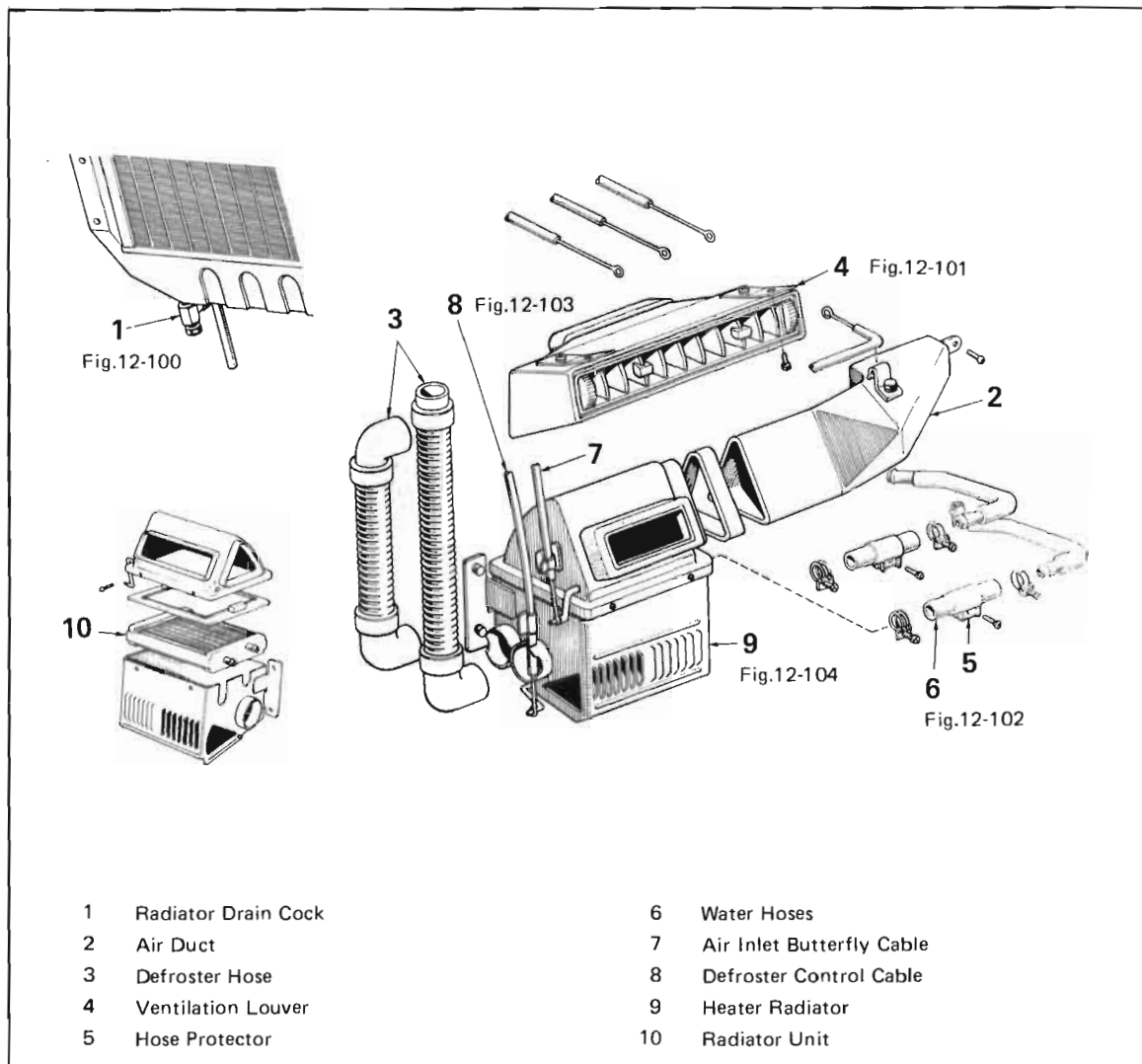

Fig. 12-100



1. Drain out the coolant through the radiator drain cock.

TRANSMISSION & TRANSFER

Illustration	Tool No.	Tool Name
	09305-60010	Gear Shift Lever Remover
	09309-36020	Transmission Rear Bearing Replacer
	09311-60010	Counter Gear Needle Roller Guide Shaft (For 3-Speed Transmission)
	09314-36010	Output Shaft Front Retainer (For 4-Speed Transmission)
	09316-60010	Transmission & Transfer Bearing Replacer
	09318-60011	Transfer Low Speed Gear Holding Tool (For Transfer)
	09319-60010	Transfer Idler Gear Shaft Remover (For Transfer)
	09323-60010	Transfer Guide Shaft (For 3-Speed Transmission)
	09330-00020	Companion Flange Holding Tool
	09506-35010	Differential Drive Pinion Rear Bearing Replacer (For 4-Speed Transmission)

STEERING

Location	kg-m (ft-lb)
Steering Gear Housing X Gear Housing End Cover	3.0 – 4.5 (21.7 – 32.5)
Steering Gear Housing X Sector Shaft End Cover	3.0 – 4.5 (21.7 – 32.5)
Steering Gear Housing X Gear Housing Bracket	4.0 – 5.5 (28.9 – 39.8)
Sector Shaft X Pitman Arm	16.5 – 19.5 (119 – 141)

BRAKE

Location	kg-m (ft-lb)
Transfer Output Shaft X Parking Brake Drum X Nut	11 – 14 (80 – 101)
Disc Brake Disc X Front Axle Hub	4.0 – 5.5 (28.9 – 39.8)
Disc Brake Caliper X Steering Knuckle	7.5 – 10.5 (54.2 – 76.0)

FRONT WINCH

Location	kg-m (ft-lb)
Power Take-Off Output Shaft X Universal Joint Flange X Nut	1.5 – 2.2 (10.9 – 15.9)
Front Winch Worm Bearing Retainer X Winch Gear Case	1.9 – 3.1 (14 – 22)

LUBRICANT

Place Used	Oil Capacity			Classification
	Liter	US qt	Imp.qt	
Transmission 4-Speed	3.1	3.3	2.7	SAE90, API GL-4
3-Speed	1.7	1.8	1.5	
Transfer	1.7	1.8	1.5	
Front Differential FJ, BJ, HJ Series	2.5	2.6	2.2	SAE90, API GL-5
Rear Differential FJ40 & BJ40	2.4	2.6	2.1	
FJ43 & BJ43	2.7	2.9	2.4	
FJ45, HJ45 & FJ55	2.9	3.1	2.6	
Steering	0.6	0.6	0.5	SAE90, API GL-4
Front Winch	0.6	0.6	0.5	
Ball Joint & Propeller Shaft Spider Grease				NLGI No.1 or No.2
Wheel Bearing Grease				NLGI No.2
Steering Knuckle & Axle Shaft Grease				Molybdenum Disulphide Lithium Base Grease
Brake Fluid				For USA : DOT 3 Other : DOT 3 or SAEJ 1703 (SAE 70R-3)

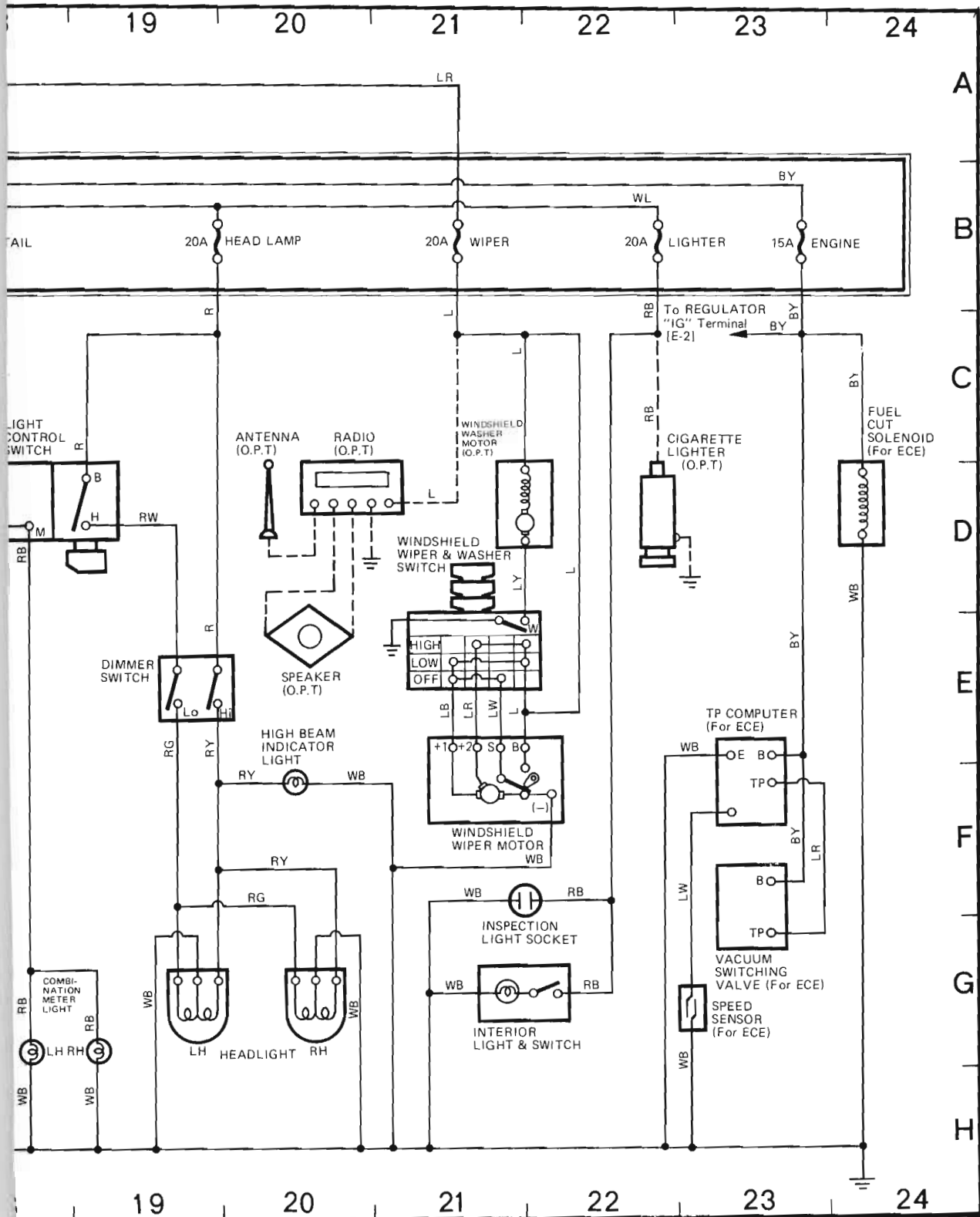

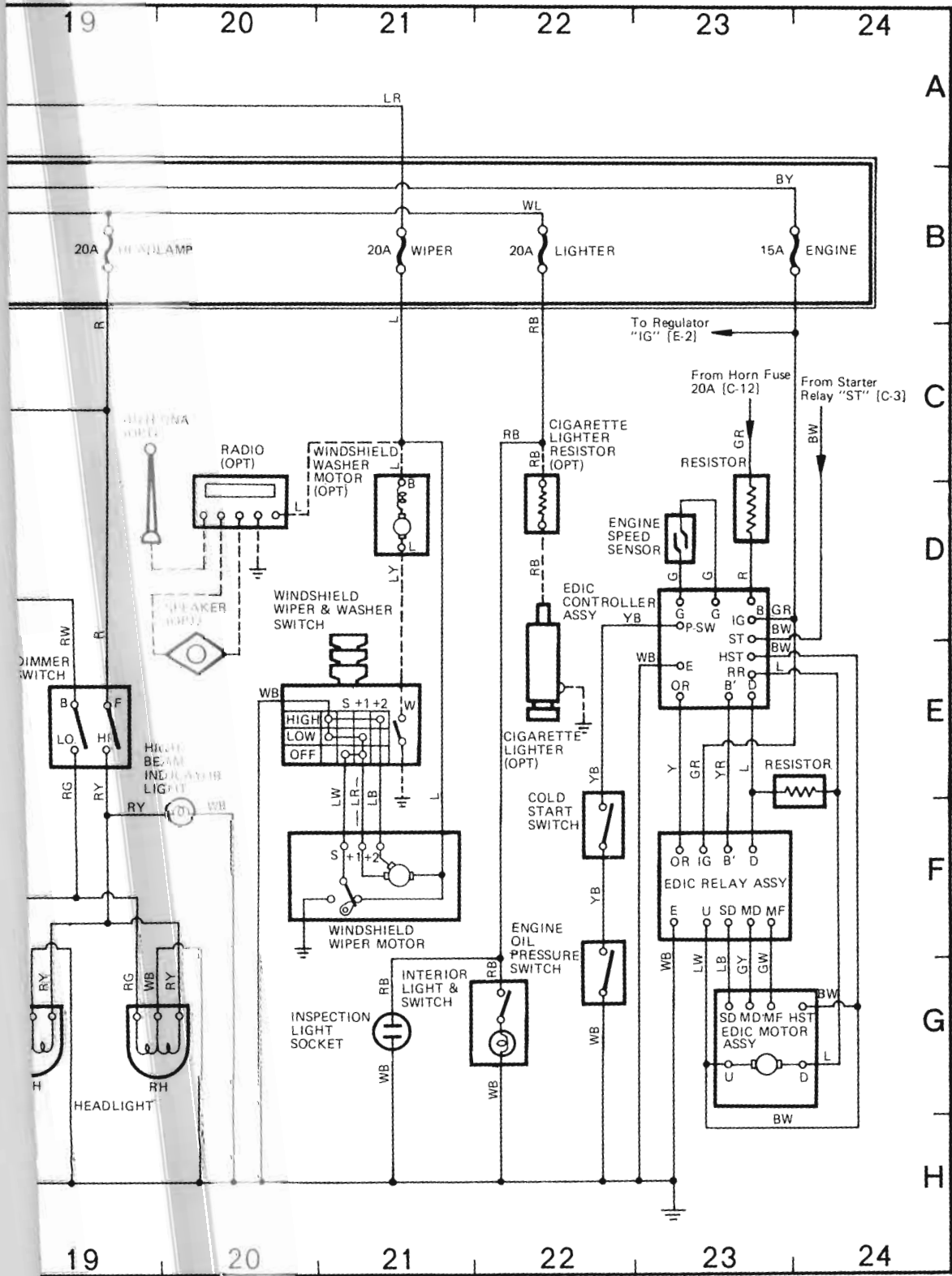

CLICK HERE TO **DOWNLOAD** THE COMPLETE MANUAL

- Thank you very much for reading the preview of the manual.
- You can download the complete manual from: www.heydownloads.com by clicking the link below



- Please note: If there is no response to CLICKING the link, please download this PDF first and then click on it.

CLICK HERE TO **DOWNLOAD** THE COMPLETE MANUAL