



BP 249 Z. I.
44 158 ANCENIS CEDEX FRANCE
TEL : 02 40 09 10 11

YOUR DEALER

REF : 547774 EN (07 / 01 / 2002)

MSI 20 G
MSI 25 G
MSI 30 G

REPAIR MANUAL

CLICK HERE TO **DOWNLOAD** THE COMPLETE MANUAL

- Thank you very much for reading the preview of the manual.
- You can download the complete manual from: www.heydownloads.com by clicking the link below



- Please note: If there is no response to CLICKING the link, please download this PDF first and then click on it.

CLICK HERE TO **DOWNLOAD** THE COMPLETE MANUAL

FOREWORD

This repair manual describes the description, construction, trouble shooting, removal, disassembly, inspection and repair, assembly and installation of the various components of the 4Y model engine equipped on the Toyota Forklift Trucks.

You are encouraged to become thoroughly familiar with this manual so as to make the most of the outstanding performance and durability features of these vehicles mounted with the 4Y engine and to perform the proper servicing to maintain them in tip-top running condition.

This repair manual contains the latest information available as of August 1986.

For any changes thereafter, you are asked to consult the Parts & Service News. Toyota reserves the right to make changes in specifications and descriptions without incurring any obligation and without previous notice.

TOYOTA MOTOR CORPORATION









STANDARD BOLT AND NUT TIGHTENING TORQUE JUDGEMENT

Standard bolt and nut tightening torques are not indicated; therefore tightening torque must be judged as below:

- Find out the type of the bolt from the list below.
Then, find the bolt tightening torque from the table.
- The nut tightening torque can be judged from the bolt type. (See the table.)

LIST OF BOLT TYPES AND STRENGTH

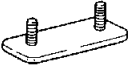
1. Judging by part

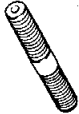
Shape and description		Type
Hexagon bolt	 Number in relief or hallmark on the head	4 = 4T 5 = 5T 6 = 6T 7 = 7T
Standard bottom surface	 No mark	4T
Hexagon bolt (Collared bottom)	 No mark	4T
Hexagon bolt (Standard bottom surface)	 Two relief lines on the head	5T
Hexagon bolt (Collared bottom)	 Two relief lines on the head	6T
Hexagon bolt	 Three relief lines on the head	7T
Welded bolt		4T
Welding bolt	 No mark	4T
Stud bolt	 Approximately 2mm (0.08 in.) hollow on either or both ends	6T

2. Judging by part No.

Hexagon bolt

Sample number
91111-40610

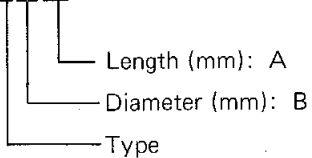

Length (mm): A
Diameter (mm): B
Type

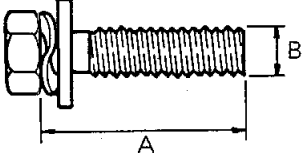

Stud bolt

Sample number
92132-40614

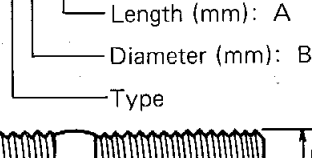

Length (mm): A
Diameter (mm): B
Type

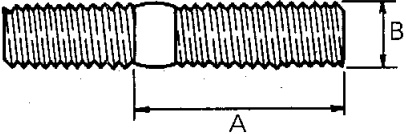

ENGINE OVERHAUL

	Page
ENGINE SECTIONAL VIEWS.....	2-2
CYLINDER HEAD	2-4
TIMING GEAR & CAMSHAFT	2-25
CYLINDER BLOCK	2-41

CYLINDER HEAD INSPECTION AND CLEANING

1. Piston and cylinder block top surface cleaning
 - (1) Rotate the crankshaft to bring each piston to the top dead center. Use a gasket scraper and remove the carbon deposit on top of the piston.
 - (2) Use the scraper and remove the gasket adhering on the cylinder block top surface.
 - (3) Use an air gun to blow off oil and foreign matters from bolt holes.

Caution:

Use cloth to prevent splashing of oil.

2. Cylinder head gasket removal
 - (1) Use the scraper and clean the cylinder head bottom surface and manifold installation surface.

Caution:

Do not damage the cylinder head during cleaning.

3. Cylinder head combustion chamber cleaning
 - (1) Use a wire brush to remove the carbon from the combustion chambers.

Caution:

Do not damage the surface to be in contact with the head gasket.

4. Valve guide bush cleaning
 - (1) Use a solvent and clean the inner surface of the valve guide bush.

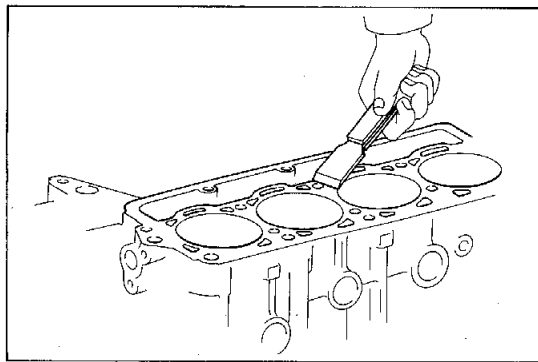

Cleaning the Cylinder Block

EM2532

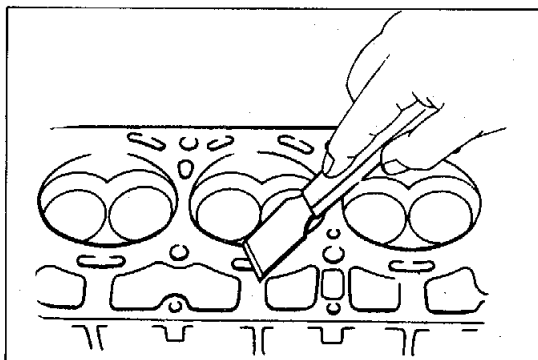

Cleaning the Cylinder Head

EM2412

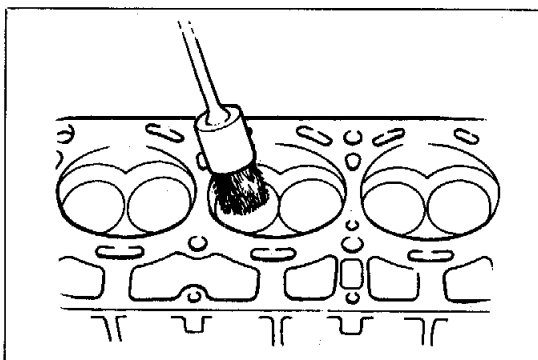

Cleaning the Cylinder Head Combustion Chambers

EM2411

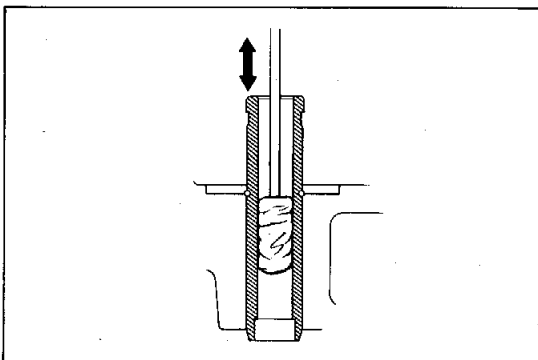

Cleaning the Valve Guide Bush

EM0028

- (4) Evenly tighten 13 cylinder head bolts in the illustrated order in several steps.

T = 9.0 kg-m (65 ft-lb)
(M12)

T = 1.95 kg-m (14 ft-lb)
(M8)

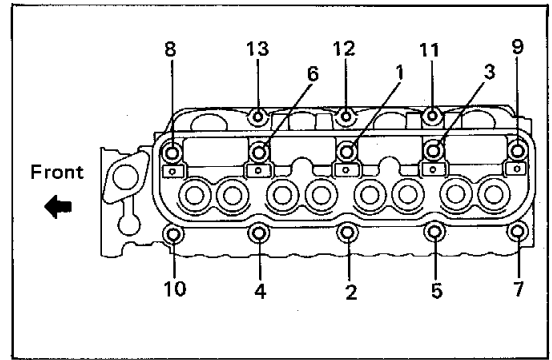

Tightening the Cylinder Head Bolts

EM2416

2. Push rod and valve rocker shaft ASSY installation

(1) Install each push rod ① at its original position before removal.

(2) Use the SST and position the push rods as illustrated.

SST 09270-71010

Caution:

Check that the push rod is surely in the lifter push rod seat portion.

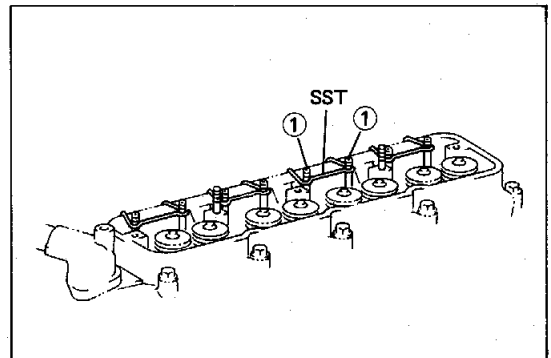

Installing the Push Rods

EM2392

(3) Install the valve rocker shaft ASSY to the cylinder head.

(4) Evenly tighten 3 bolts and 2 nuts in the illustrated order in several steps.

T = 2.40 kg-m (17 ft-lb)

Caution:

Keep the push rods from leaving the rocker arm, and tighten the bolts and nuts.

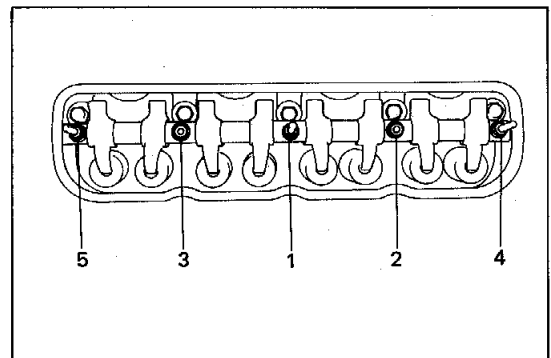

Installing the Valve Rocker Shaft ASSY

EM2417

3. Water pump ASSY installation

(1) Install a new gasket.

(2) Install the water pump ASSY.

(3) Tighten 4 set bolts.

T = 1.85 kg-m (13 ft-lb)

(4) Install the water inlet hose.

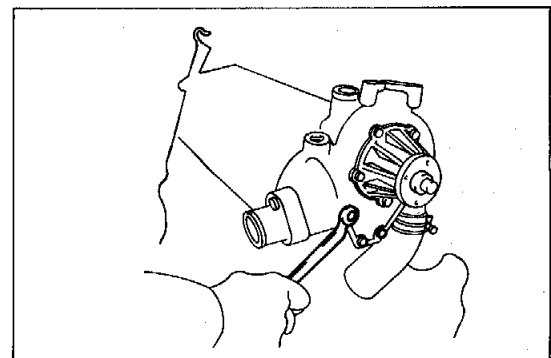

Installing the Water Pump ASSY

KAJS6

19. Thrust plate and camshaft removal
- (1) Remove two bolts, and remove the thrust plate.
 - (2) Extract the cam shaft.

Caution:

Do not damage the camshaft bearing.

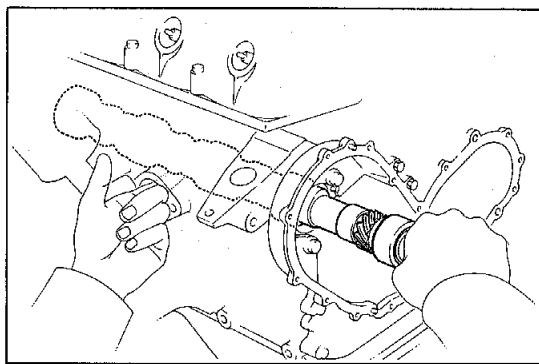

Removing the Camshaft

KAJS13

CYLINDER BLOCK

COMPONENTS

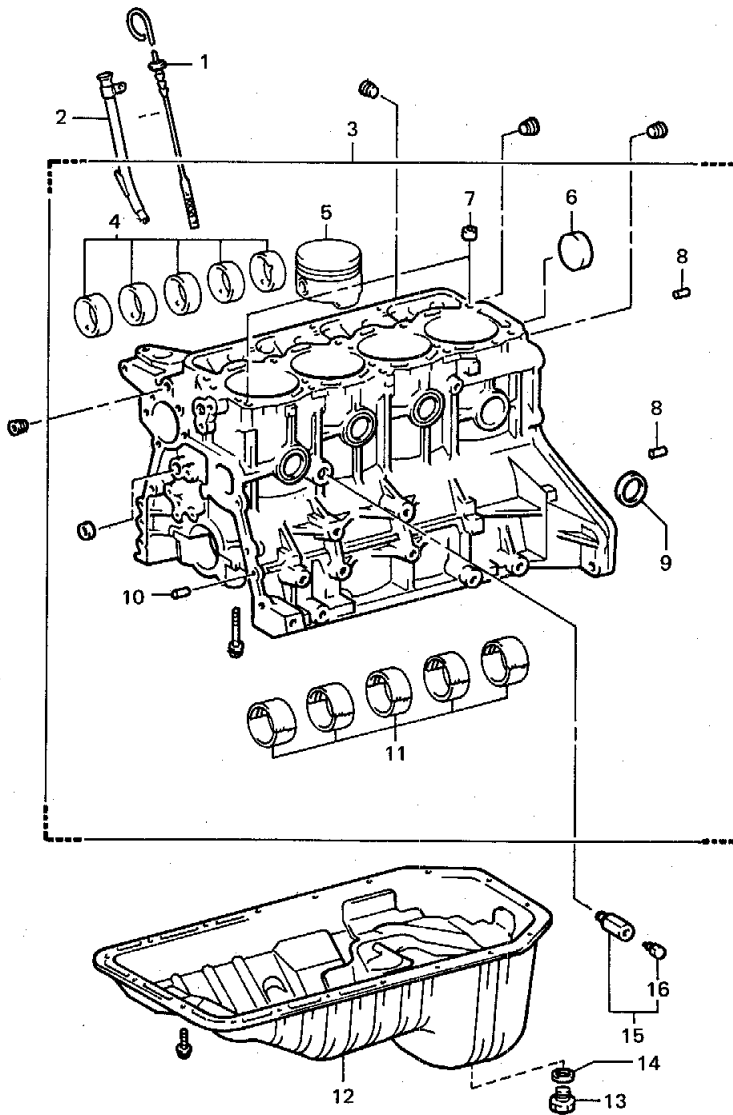

- | | |
|-----------------------------|-------------------------|
| 1. Oil level gauge SUB-ASSY | 9. Tight plug No. 2 |
| 2. Oil level gauge guide | 10. Straight pin |
| 3. Cylinder block SUB-ASSY | 11. Crankshaft bearing |
| 4. Camshaft bearing set | 12. Oil pan SUB-ASSY |
| 5. Piston SUB-ASSY | 13. Plug |
| 6. Tight plug No. 1 | 14. Gasket |
| 7. Ring pin | 15. Drain cock SUB-ASSY |
| 8. Straight pin | 16. Drain cock plug |

- (2) Arrange the removed pistons, piston pins, piston rings and connecting rods in the order of the corresponding cylinders.

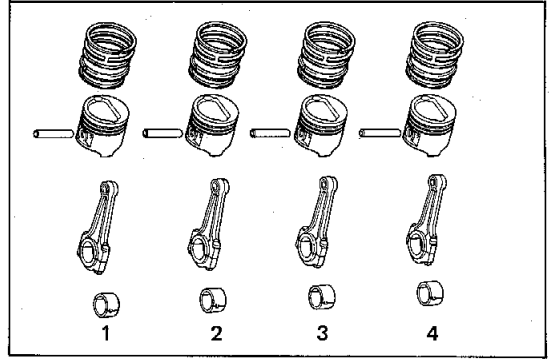

Arranging the Pistons, Piston Pins, Rings and Rods

EM1403

PISTON AND CONNECTING ROD INSPECTION

1. Piston cleaning

- (1) Use a scraper and remove the carbon from the top surface of each piston.

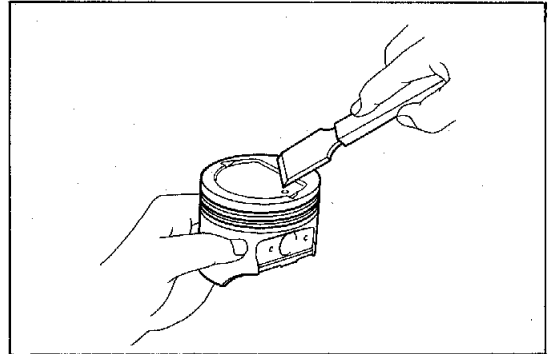

Cleaning the Piston (1)

EM2550

- (2) Remove the carbon from each ring groove with an unnecessary piston ring.

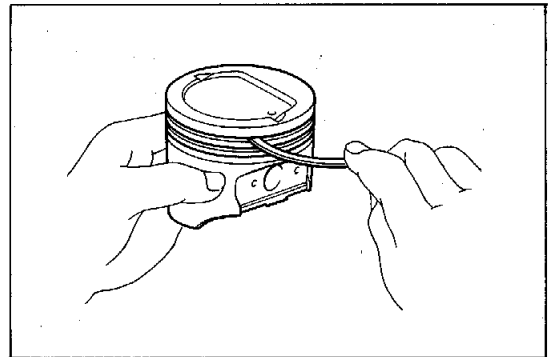

Cleaning the Piston

EM2336

- (3) Wash each piston with a solvent.

Caution:

Do not use a hard wire brush.

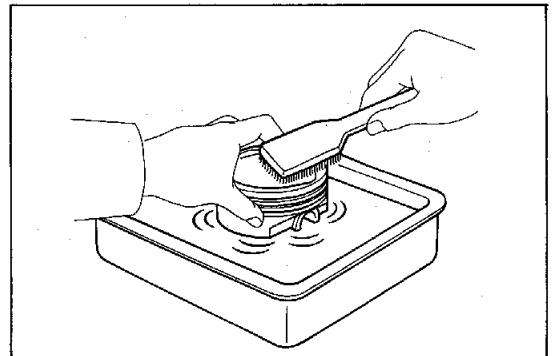

Washing the Piston

EM2551

CYLINDER BLOCK ASSEMBLY

Caution:

- Thoroughly clean the parts to be assembled.
- Coat engine oil on the sliding contact and rotating surfaces before assembly.
- Replace gaskets, oil seal and other non-reusable parts with new ones.

1. Crankshaft bearing installation

Caution:

Keep the bearing outer surfaces (in contact with the cylinder block or bearing caps) free from oil.

- (1) Install the upper bearing having an oil groove on the whole periphery, with the cylinder block oil hole and lock groove as the guide.
- (2) Install the lower bearing by fitting with the bearing cap lock groove.
- (3) Install the upper thrust washer to the No. 3 journal supporting portion, with the oil grooves facing outward.
- (4) Install the lower thrust washer to the No. 3 bearing cap, with the oil grooves facing outward.

Reference:

Coat engine oil on the rear face of the thrust washer to prevent falling.

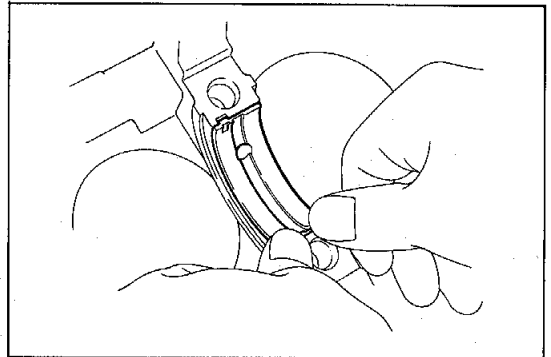

Crankshaft Bearing Installation

EM0388

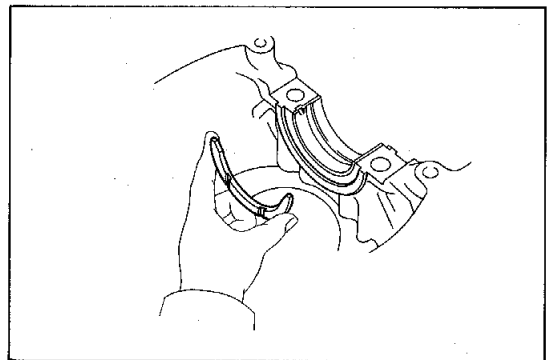

Installing the Upper Thrust Washer

EM0247

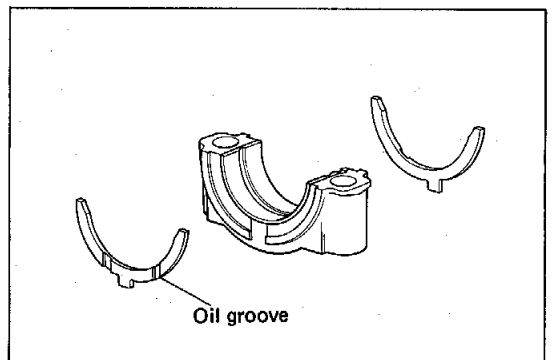

Installing the Lower Thrust Washer

EM1703

COMPONENTS

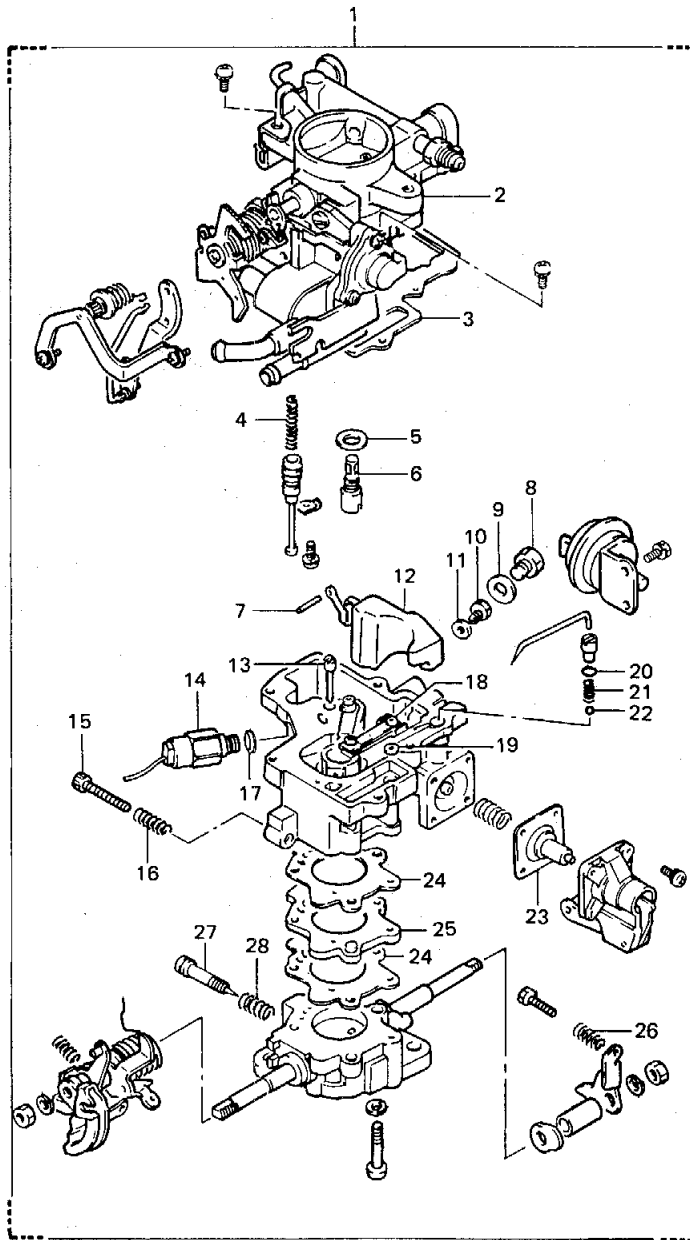

- | | | |
|-----------------------------|------------------------------|---------------------------------|
| 1. Carburetor ASSY | 11. Gasket | 21. Spring |
| 2. Air horn | 12. Float | 22. Steel ball |
| 3. Air horn gasket | 13. Slow jet | 23. Accelerating pump diaphragm |
| 4. Spring | 14. Solenoid valve | 24. Gasket |
| 5. Needle valve seat gasket | 15. Throttle adjusting screw | 25. Insulator |
| 6. Needle valve | 16. Spring | 26. Spring |
| 7. Float lever pin | 17. Gasket | 27. Idle adjusting screw |
| 8. Main passage plug | 18. Hot idle compensator | 28. Spring |
| 9. Gasket | 19. Gasket | |
| 10. Main jet | 20. O-ring | |

Carburetor Components

KAJM9

7. Power valve sliding inspection

- (1) Push the power valve rod ① lightly with a finger, and check that it slides smoothly.

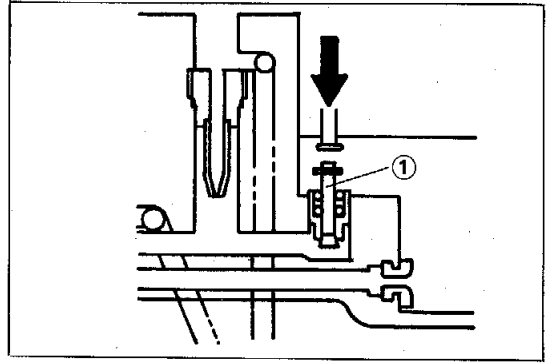

Inspecting the Power Valve Sliding Status

KAJS39

8. Idle adjusting screw inspection

- (1) Check that the tapered portion of the idle adjusting screw is not stepped and that the threaded portion is not damaged.

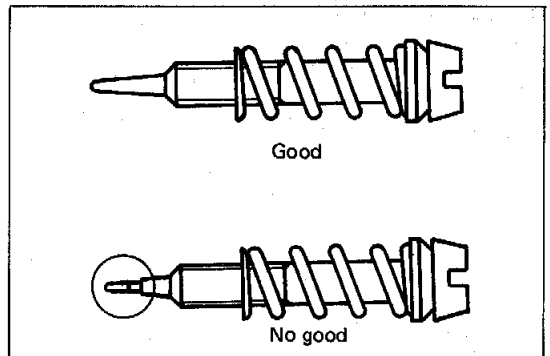

Inspecting the Idle Adjusting Screw

KAJS40

10. Idle-up actuator inspection

- (1) Check that the rod moves when a negative pressure is applied to the diaphragm chamber.
- (2) Check that the rod quickly returns to the original position when the negative pressure is set from the state in (1) to zero.

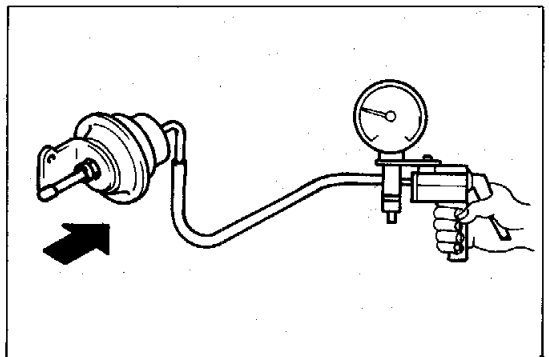

Inspecting the Idle-up Actuator

KAJS41

FAST IDLE CAM ADJUSTMENT

Caution:

- Adjust the fast idle when the ambient temperature is $25 \pm 2^\circ$.
- Do not make adjustment unless it is absolutely necessary.

1. Turn the adjust screw ① to bring the I mark ③ on the fast idle cam ② to the center of the fast adjust lever roller pin ④. Tighten the lock nut.
2. After I mark alignment, adjust the fast idle opening angle ⑤ (See to 3-24)

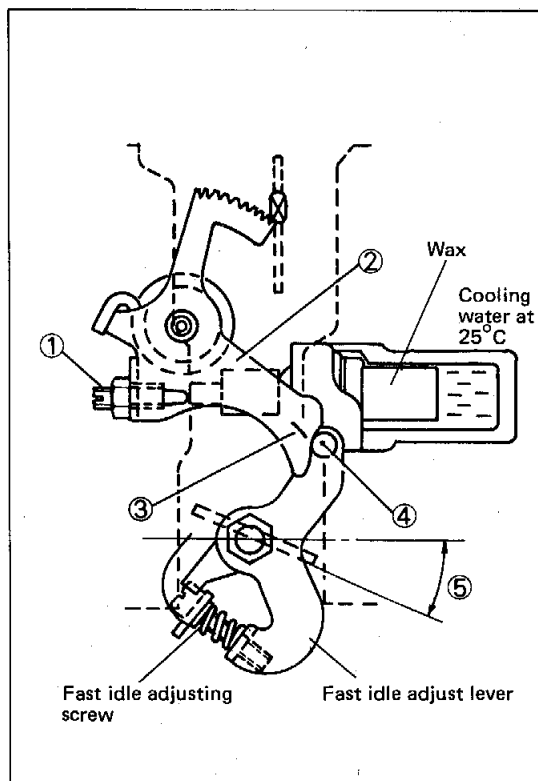

Adjusting the Fast Idle Cam

KAJS48

CHOKE VALVE ADJUSTMENT

Caution:

Do not make adjustment unless it is absolutely necessary.

1. After I mark alignment, match the rack ① and pinion ② positions when the ambient temperature is $25 \pm 2^\circ\text{C}$.
2. Turn the pinion until the leftmost tooth of the rack matches the pinion teeth on both sides of the matching mark ③.
3. Turn the pinion lever ④ clockwise until the choke lever is at 16 to 21° degrees from the horizontal level. Tighten set screws ⑤ and ⑥.

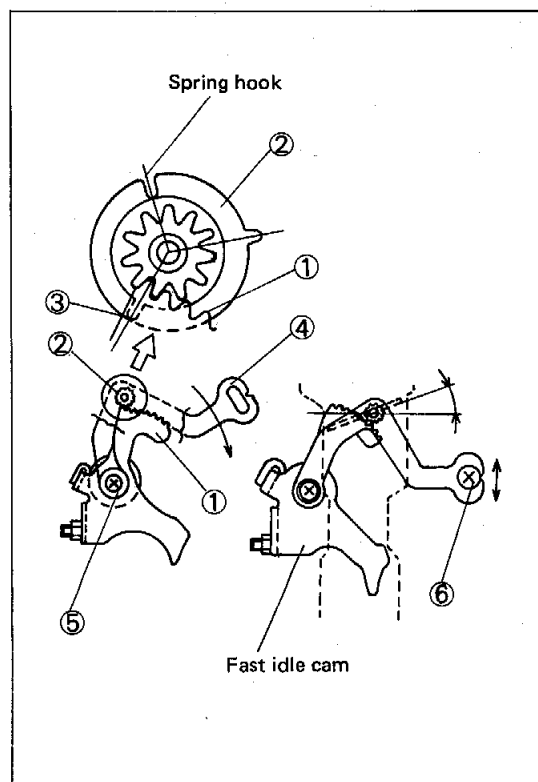

Adjusting the Choke Valve

KAJS49

PCV SYSTEM

	Page
GENERAL	4-2
VENTILATION VALVE	4-2

2. Water bypass flange installation
 - (1) Drive in the bypass flange to the water pump inlet portion. The notch on the flange shall face the inlet mounting bolt hole direction.
3. Thermostat installation
(See page 5-5.)

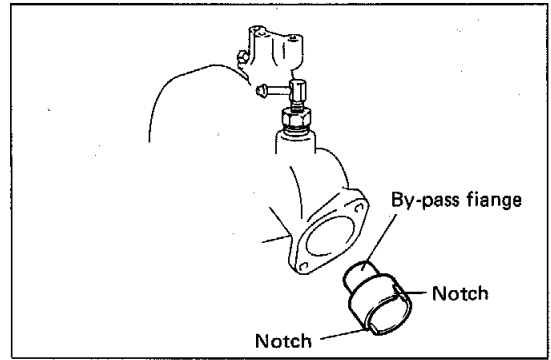

Installing the Water Bypass Flange

KAJS92

4. Water pump installation
 - (1) Remove the old gasket adhered on the water pump and cylinder block.
 - (2) Install the water pump with a new gasket in-between, and tighten four set bolts.
T = 1.85 kg-m
 - (3) Connect the water inlet hose to the water pump.
 - (4) Install the water outlet pipe union bolt.
5. Radiator outlet hose installation
Fan pulley, V-belt and fan installation.
See page 1-3 for V-belt adjustment.

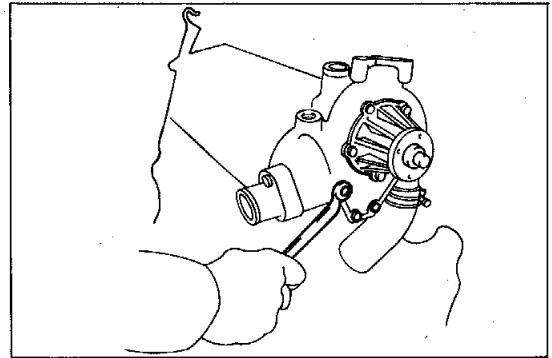

Installing the Water Pump Cover

KAJS66

6. Coolant filling
(See page 5-5.)
7. Water leak check

4. Drive and driven rotor inspection

- (1) Use a thickness gauge, and measure the clearance between the driven rotor and pump body.

Standard:

0.1 – 0.15 mm (0.0039 – 0.0059 in.)

Limit: 0.2 mm (0.008 in.)

If the clearance exceeds the limit, replace the rotors as a set.

If necessary, replace the whole oil pump ASSY.

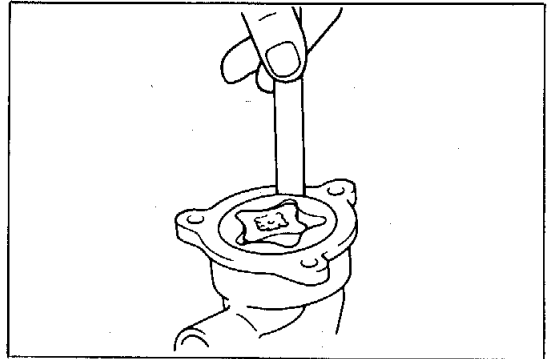

Measuring the Clearance between Driven Rotor and Body

LU0300

- (2) Use a straight edge and thickness gauge, and measure the rotor side clearance.

Standard:

0.03 – 0.07 mm (0.0012 – 0.0028 in.)

Limit: 0.15 mm (0.0059 in.)

If the clearance exceeds the limit, replace the rotors as a set.

If necessary, replace the whole oil pump ASSY.

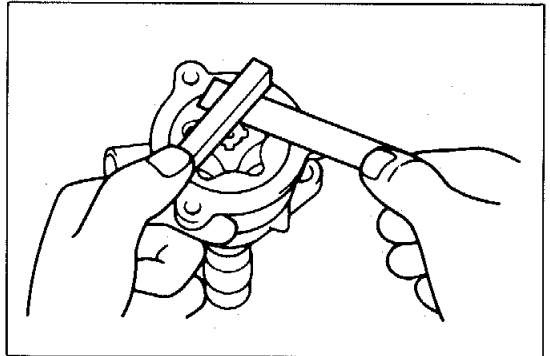

Measuring the Rotor Side Clearance

LU0302

- (3) Use the thickness gauge and measure the tip clearance between the drive and driven rotors.

Standard:

0.07 – 0.12 mm (0.0028 – 0.0047 in.)

Limit: 0.02 mm (0.008 in.)

If the clearance exceeds the limit, replace the rotors as a set.

If necessary, replace the whole oil pump ASSY.

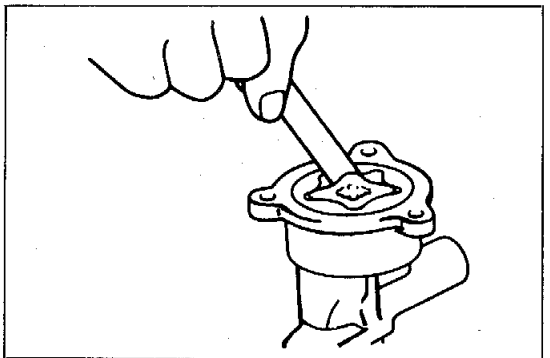

Measuring the Rotor Tip Clearance

LU0301

5. Drive and driven rotor removal

- (1) Remove the drive and driven rotors from the pump body.

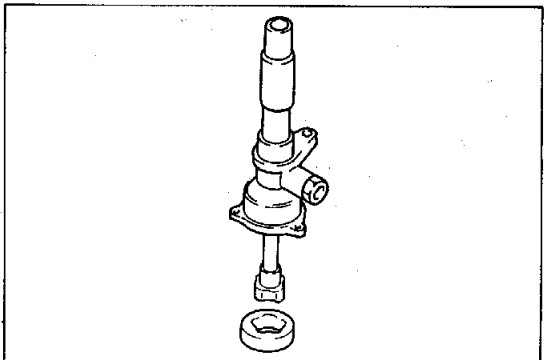

Removing the Rotors

KAJS71

14. Distributor cap with resistive cord installation
 - (1) Install the gasket to the distributor housing.
 - (2) Install the distributor cap and tighten 3 screws.
15. Install new O-ring to the housing.

Note:

Coat engine oil thinly on the O-ring.

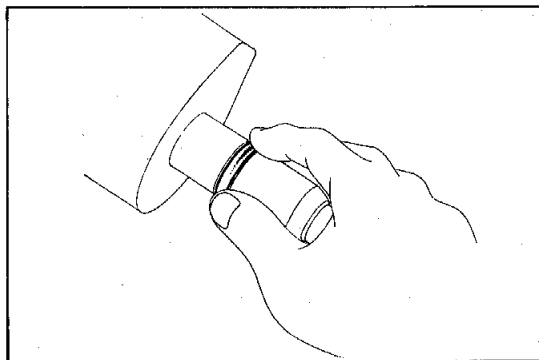

Installing the O-ring

IG0522

DISTRIBUTOR INSTALLATION

1. Set No. 1 cylinder compression TDC as follows:
 - (1) Remove No. 1 spark plug.
 - (2) Cover the hole of No. 1 spark plug with a finger tip. Turn the crankshaft clockwise. When pressure is felt, No. 1 cylinder is at the compression TDC.
 - (3) Install No. 1 spark plug.
2. Oil pump drive shaft groove setting
 - (1) Set the shaft groove to point about 1 o'clock (30°) direction as viewed from above.

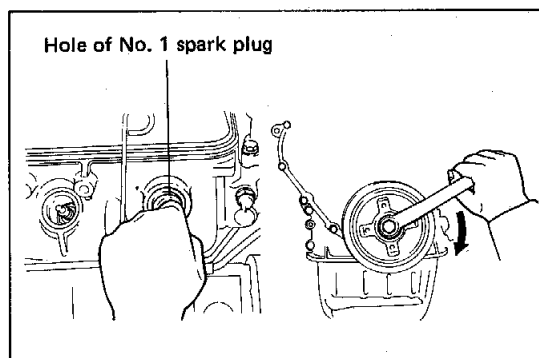

Setting No.1 Cylinder Compression Top Dead Center

IG0082, KAJ586

3. Distributor installation
 - (1) Align the housing groove with the spiral gear drill mark. (Do not align with the spiral gear straight pin.)
 - (2) Insert the distributor parallel with the engine.

Caution:

Insert the distributor by nearly aligning the block installation screw hole with the center of installation flange groove.

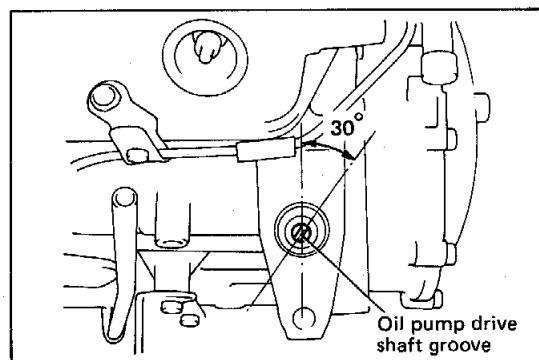

Oil Pump Drive Shaft Groove Position

IG0084

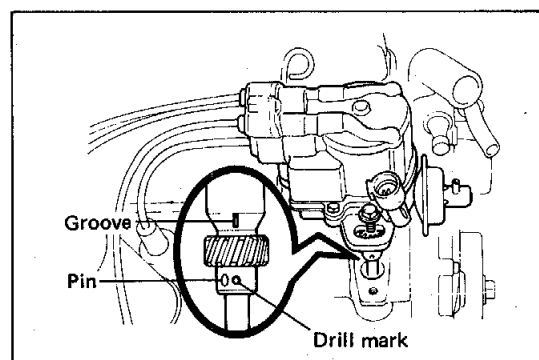

Installing the Distributor

IG0087

- (3) Temporarily tighten the set bolts.

7. Brush test

- (1) Inspect roughening of the contact surface and the brush length.

Standard: 15 mm (0.591 in.)

Limit: 10 mm (0.394 in.)

- (2) For contact surface repair or brush replacement, wrap sand paper around the commutator to correct the brush surface.

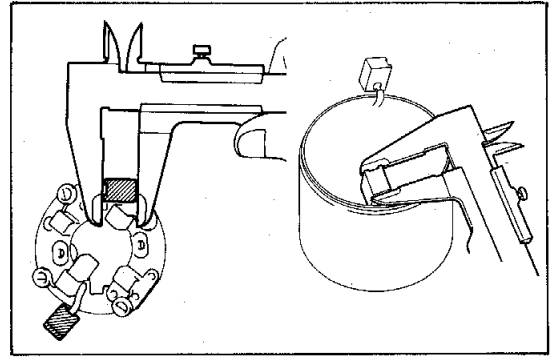

Inspecting the Brush

ST0017,0018

8. Brush spring inspection

- (1) Check the brush spring for smooth movement. Measure the installed load.

Standard: 1785 – 2415 g

(3.93 – 5.32 lb)

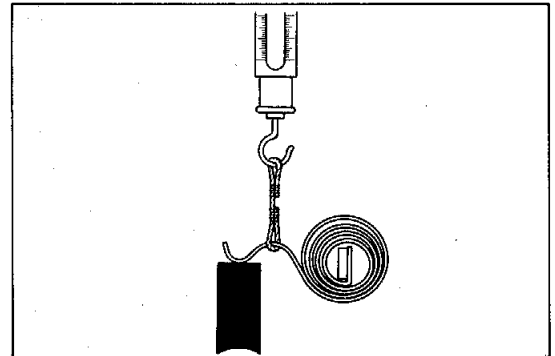

Inspecting the Brush Spring

ST0019

9. Brush holder inspection

- (1) Inspect the insulation between the positive and negative brushes.

Standard: No conduction

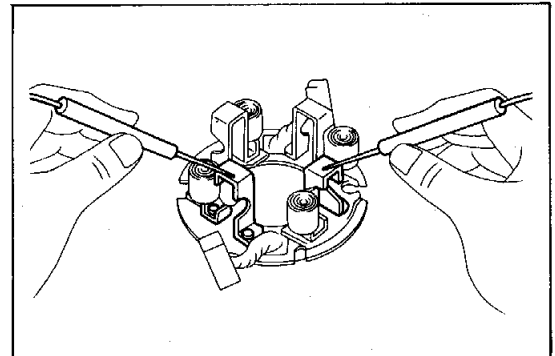

Inspecting the Brush Holder

ST0062

10. Clutch and gear inspection

- (1) Inspect wear and damages of the gear.
 (2) Check that the gear is locked when rotated in the driving direction (counterclockwise). Check that the gear movement is smooth when turned in the opposite (clockwise) direction.

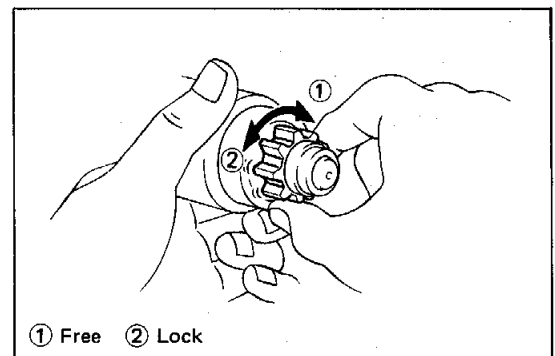

① Free ② Lock

Inspecting the Clutch & Gear

ST0020

Caution:

The following description explains removal and installation procedures of the alternator ASSY on the vehicle.

REMOVAL

1. Battery negative terminal removal
2. Alternator wiring disconnection.
3. V belt loosening
4. Alternator ASSY removal

DISASSEMBLY

1. Terminal insulator removal
2. Rear end cover removal
 - (1) Screws (3 pcs.)
 - (2) Rear end cover
3. Brush holder SUB-ASSY removal
 - (1) Screws (2 pcs.)
 - (2) Brush holder SUB-ASSY
4. IC regulator ASSY removal
 - (1) Screw (3 pcs.)
 - (2) IC regulator ASSY

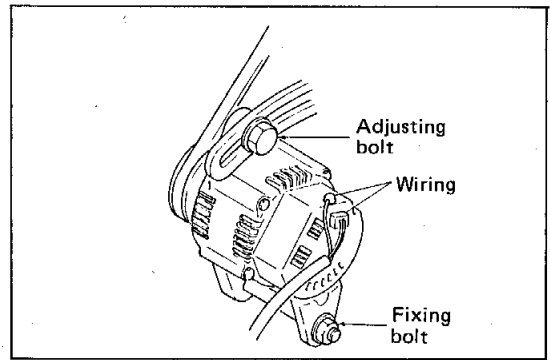

Alternator ASSY

KAJS83

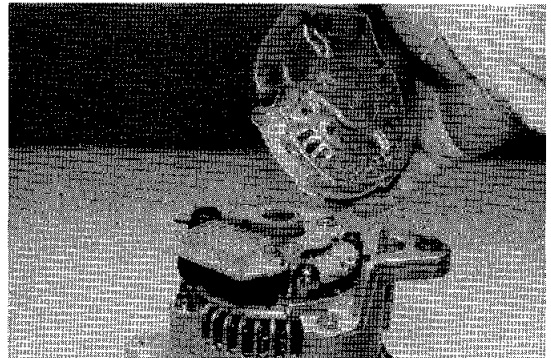

Removing the Rear End Cover

KAH21-7

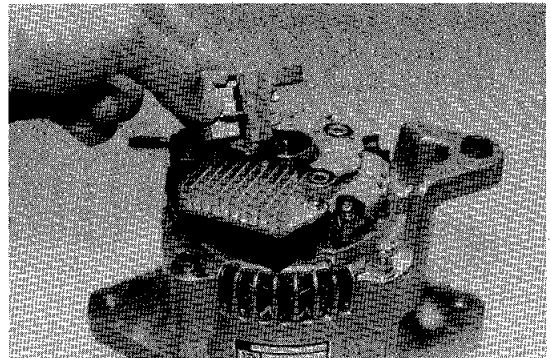

Removing the Brush Holder SUB-ASSY

KAH21-12

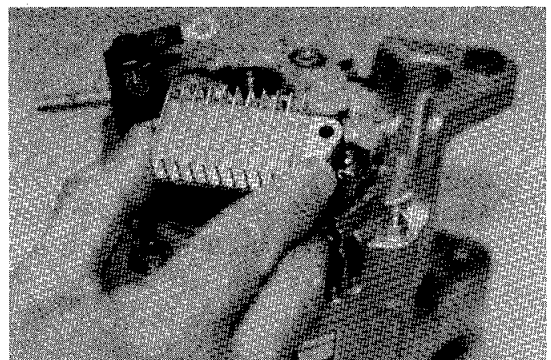

Removing the IC Regulator

KAH21-16







CLICK HERE TO **DOWNLOAD** THE COMPLETE MANUAL

- Thank you very much for reading the preview of the manual.
- You can download the complete manual from: www.heydownloads.com by clicking the link below

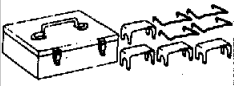

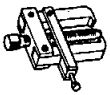
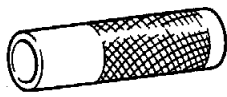
- Please note: If there is no response to CLICKING the link, please download this PDF first and then click on it.

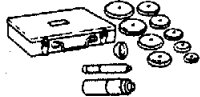
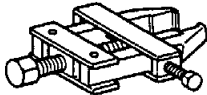
CLICK HERE TO **DOWNLOAD** THE COMPLETE MANUAL

SST Description Section			1	2	3	5	6	8	9
SST Part Name									
SST Part Number									
SST									
	09270-71010	Tool set, rocker arm support		○					
	09276-71010	Tool, valve lifter		○					
	09286-46011	Puller, injection pump spline shaft						○	
	09381-41950-71	Replacer, H.S.T. pump bearing		○					○
	09410-40120-71	Replacer, steering worm bearing		○					
	09608-35014	Tool set, axle hub and drive pinion bearing		○					
	09820-00021	Puller, alternator rear bearing							○
	09860-11011	Carburetor driver set			○				
	09950-20017	Puller, universal		○					

Commutator	Ellipticity mm (in.)	Standard	0.02 (0.0008)
		Limit	0.05 (0.0020)
	Outside diameter mm (in.)	Standard	30 (1.18)
		Limit	29 (1.14)
	Undercut mm (in.)	Standard	0.5 – 0.8 (0.020 – 0.031)
		Limit	0.2 (0.008)
Brush	Length mm (in.)	Standard	15 (0.591)
		Limit	10 (0.394)
	Spring installed load g (lb)	Standard	1785 – 2415 (3.93 – 5.32)

CHARGING SYSTEM

ALTERNATOR

Nominal voltage		V	12
Maximum output		A	35
Unloaded characteristics	Adjusted voltage V	Standard	14.2 – 14.8
	Adjusted current A	Standard	10 or less
Brush length	mm (in.)	Standard	10.5 (0.413)
		Limit	1.5 (0.059)
Slip ring outside diameter	mm (in.)	Standard	14.4 (0.567)
		Limit	14.0 (0.551)
Rotor coil resistance		Ω	2.9 Ω or less
Resistance between stator coil and each phase		Standard	0.1 M Ω or more
Resistance between slip ring and rotor core		Standard	1 Ω

CONTENTS

1 – SPECIFICATIONS 4

2 – DIMENSIONS 5

3 – DIAGRAM 6

4 – OPERATION 8

5 – TECHNICAL SHEET 11

VACUUM FUELOCK FILTER REPAIR METHOD

VFF30

12-3-2 EN

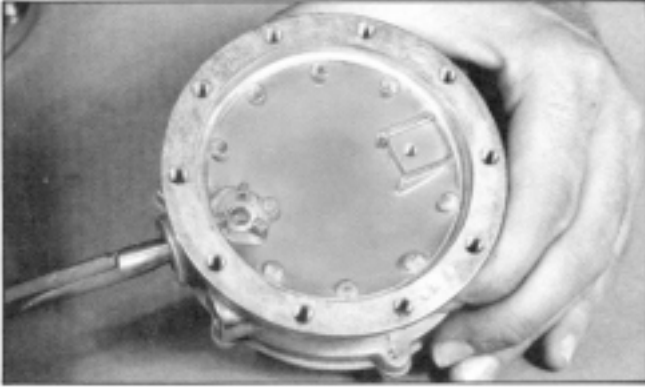

21. Insert seal retainer washer in slot to hold "O" ring in place.



22. Insertion of valve operating pin will retain washer and "O" ring in place.

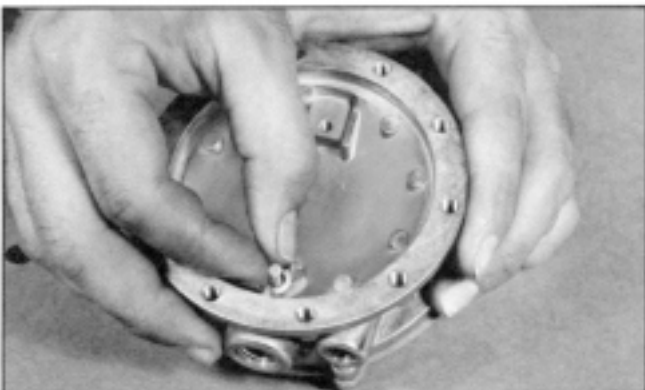

23. Insert pin, lubricated with silicone grease, through hole in retainer washer and "O" ring. Again rotate head of pin gently in a circular motion to ease pin into place through washer, "O" ring and body housing.



24. Shows valve operating pin in place in valve jet.

CONTENTS

1 – REPAIR ADVICE	4
2 – REPAIR METHOD	5
3 – TECHNICAL SHEET.....	9
4 – SERVICING.....	10

WHEEL DRIVE GEAR 207094

30-3-61EN



Mount a proper fitting into the hole that is still open on the cover to connect the drive gear to the compressed air supply at a pressure of 0.5 bar. Then use the specific instruments designed to check the pressure inside the reducer and check for any leaks.

After the test, if a leak was found in the oil sump, the water immersion test must be performed to locate the leak.

The immersion test can also be carried out as the only alternative test if specific instruments are not available to check the pressure. Just leave the drive gear attached to the compressed air tube and always at a pressure of 0.5 bar.

Then immerse the drive gear with the relative connections, into a tank of water and note if any air bubbles rise to the surface.

If so, this means that the drive gear leaks. Therefore, find the point where the air comes out of the drive gear, remove the water and take the necessary actions.

5.3 Wheel drive gear braking torque test:



Lock the hub-ring gear of the wheel drive gear with the motor side facing up.

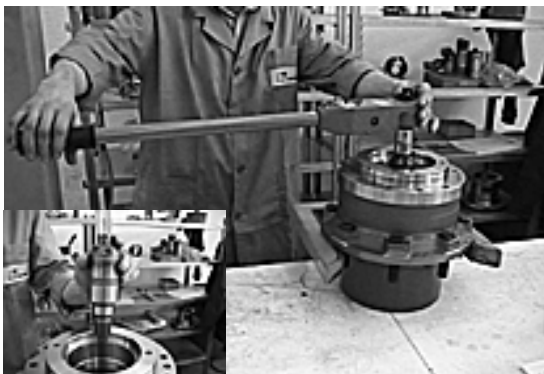

Check the torque using a special torque wrench with precision +/- 4% that is properly connected to the brake shaft.

With the brake closed: the brake must slide with an applied torque of 220 Nm with a tolerance of +/- 10%..

With the brake under pressure, use a depth gauge, for example, to measure the distance from the engine surface to the brake piston surface.

Repeat the same operation after releasing the pressure on the brake.

Then determine the difference between the two values measured.

The result must be 1.5 ± 0.5 mm.

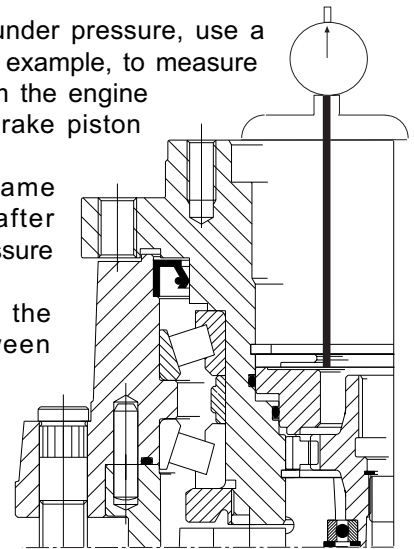

ATTENTION: if the measured

value does not comply with the rating, this means that : a part was mounted incorrectly , thus review the assembly procedure, or there is an incorrect spacing dimension of the parts that are needed to obtain this value. In this case, contact the "S.A.V." service department.

6. WHEEL DRIVE GEAR DISASSEMBLY:

In general, there is nothing particularly difficult about disassembling our drive gears - just reverse the assembly steps and try not to ruin the parts comprising the unit. Only in some cases is it necessary to be familiar with or have the necessary instructions.

For this type of drive gear, in order to work on the "brake" part or the "reduction" part, it is not necessary to disassemble the drive gear from the middle: it is necessary in order to work on the "bearing" part or "seal" part.

Drain the lubricating oil from the wheel drive gear, removing the plugs on the cover M10x1 DIN 908.

6.1 "Reduction" unit disassembly:



Remove the retaining ring BR D.205 from its seat that keeps the cover locked.

CYLINDER DISASSEMBLY

70-3-80-M43 EN

L.H. LIFTING CYLINDER

MSI 20 / 25 / 30 G + BUGGIE

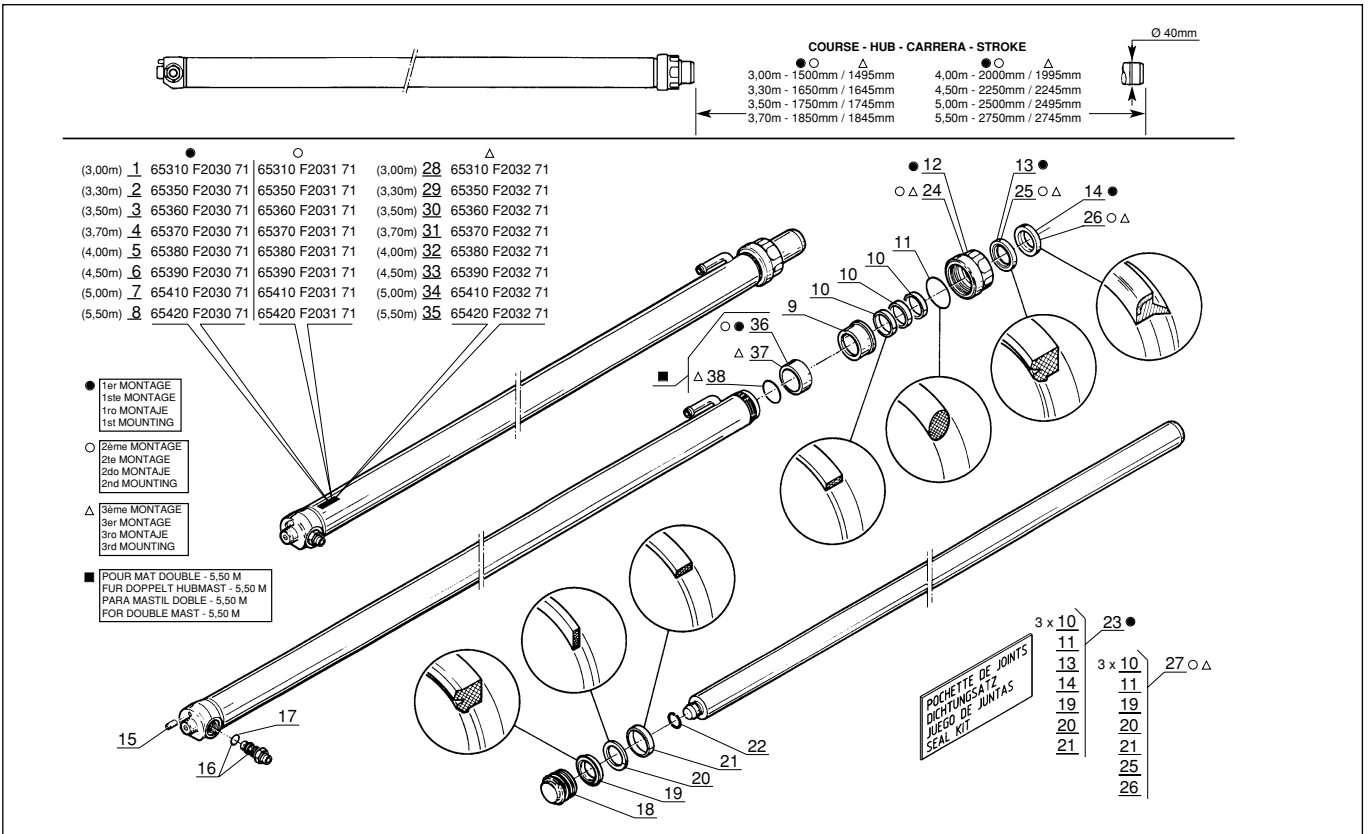

R.H. LIFTING CYLINDER

MSI 20 / 25 / 30 G + BUGGIE

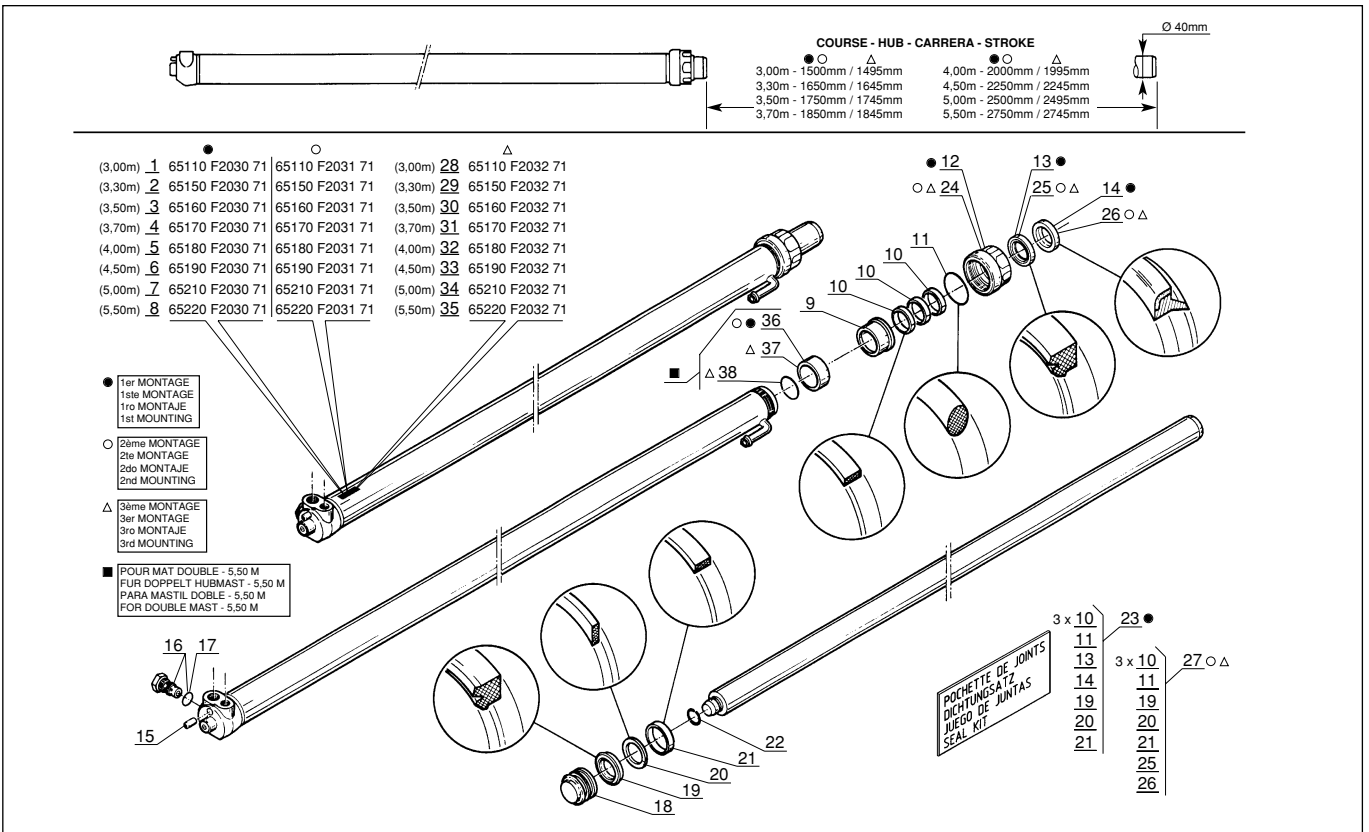



GROUP 75

HYDROSTATIC

REPAIR INSTRUCTIONS

Sealing of the drive shaft

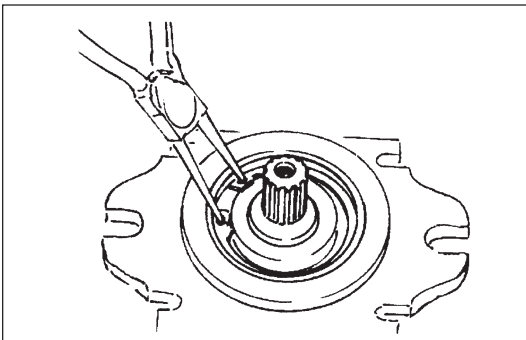
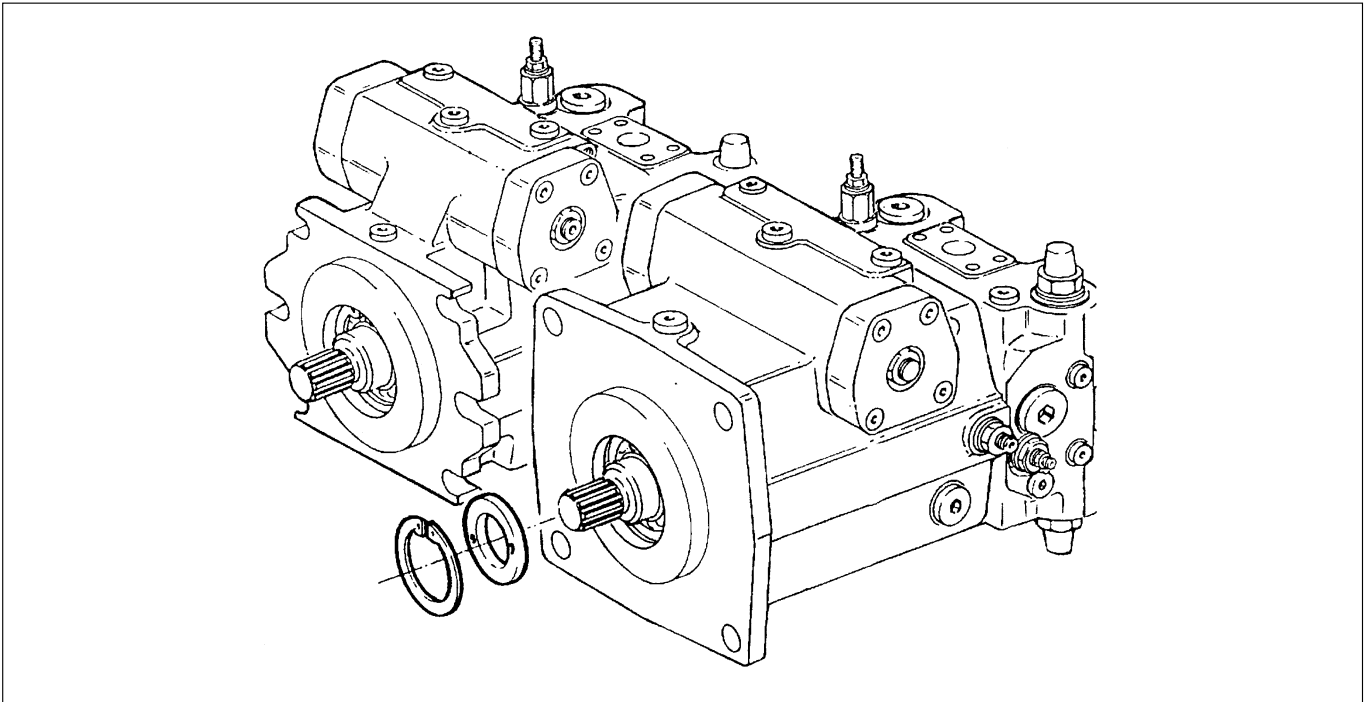

Protecting the drive shaft.
Remove retaining ring.

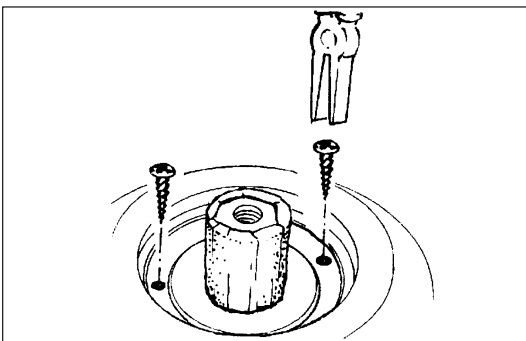

Screw in sheet metal screw into the holes fitted with rubber.
Pull out shaft seal with pliers.

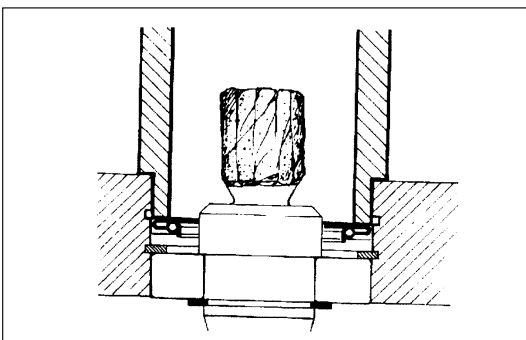

Press-in shaft seal with bush to stop.
Assemble retaining ring.

REPAIR INSTRUCTIONS

Sealing of the regulator valve

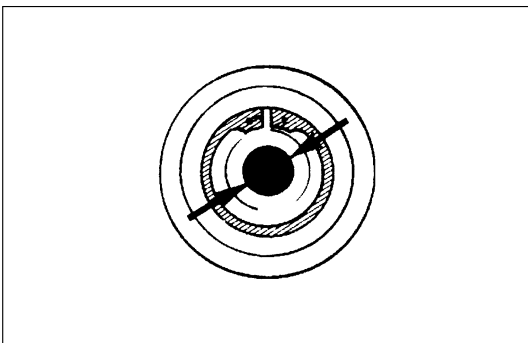
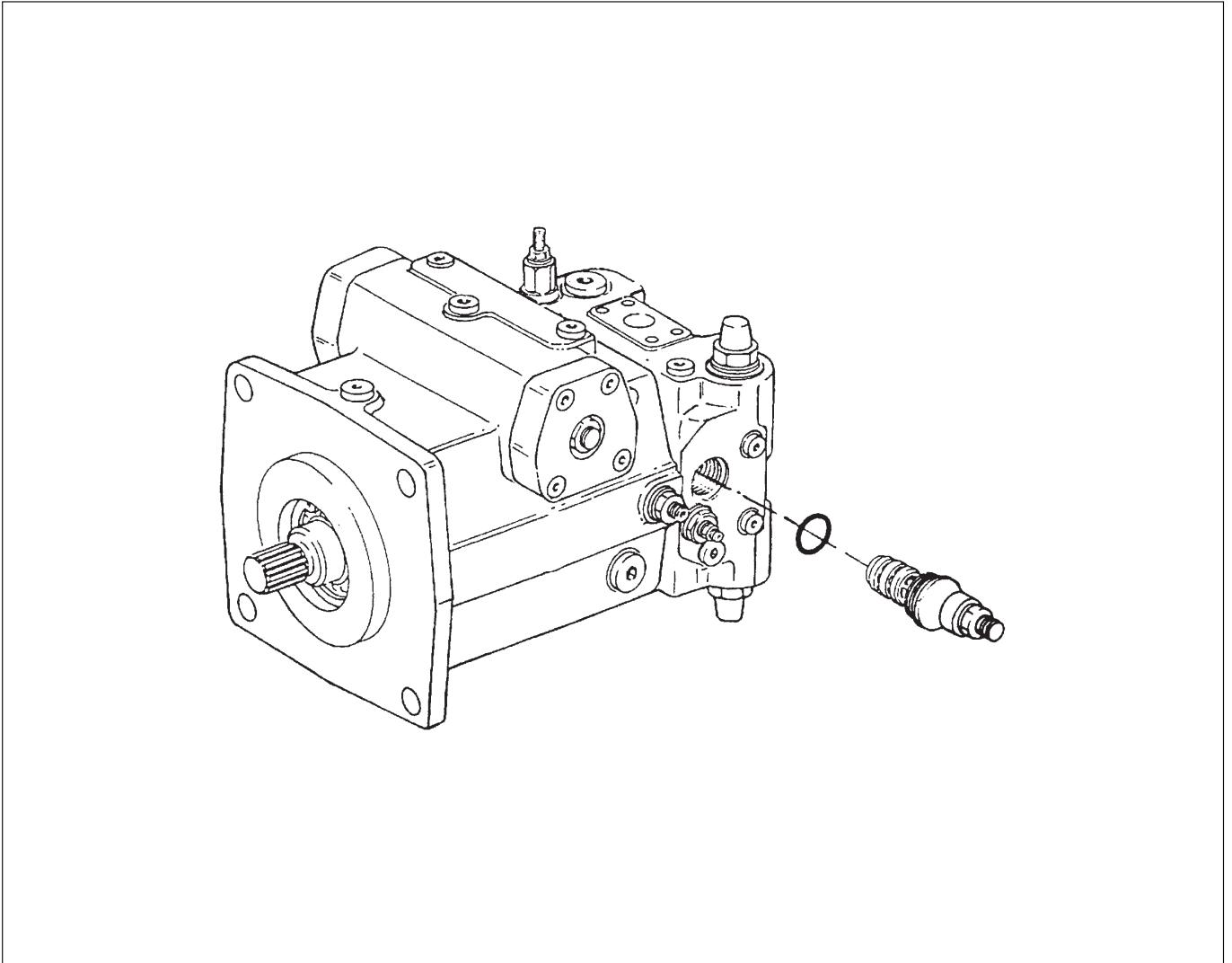

Inspect orifice.
No damage.

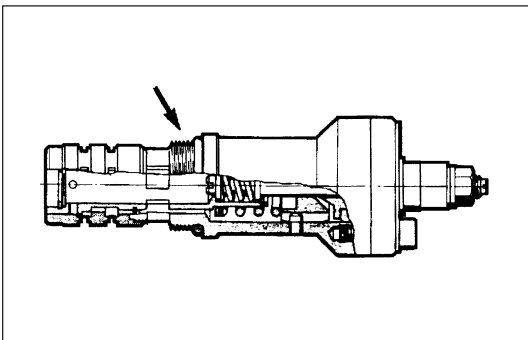

Cover threads.
Insert O-ring.

REPAIR NSTRUCTIONS

Installation of the rotary group

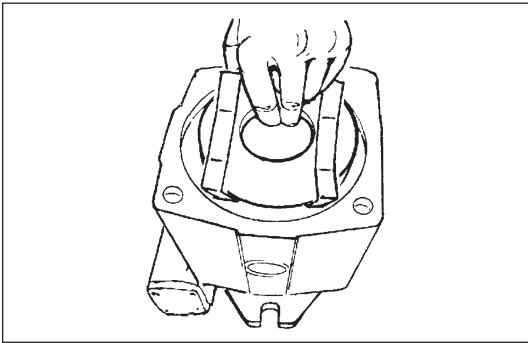

Insert completely swivel cradle into the housing.
Pay attention for correct seat of the swivel cradle in the housing.

 Remove auxiliary device.

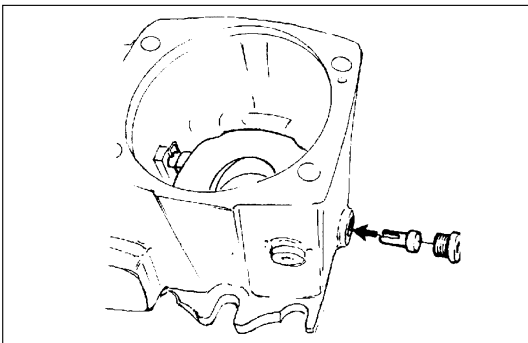

Assemble articulating pins.

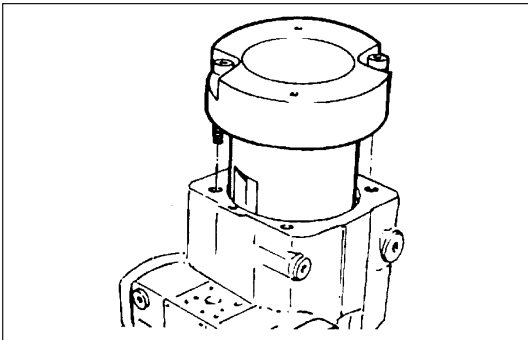

Assemble device for fixation of the swivel cradle.

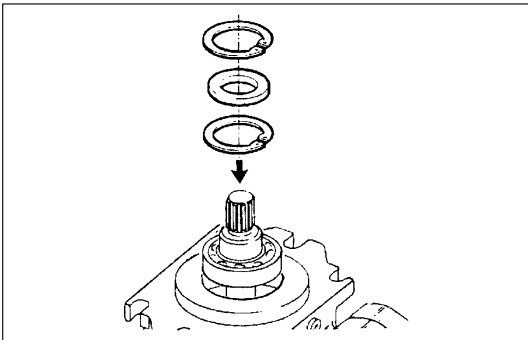

Assemble drive shaft with bearings and radial seal rings.

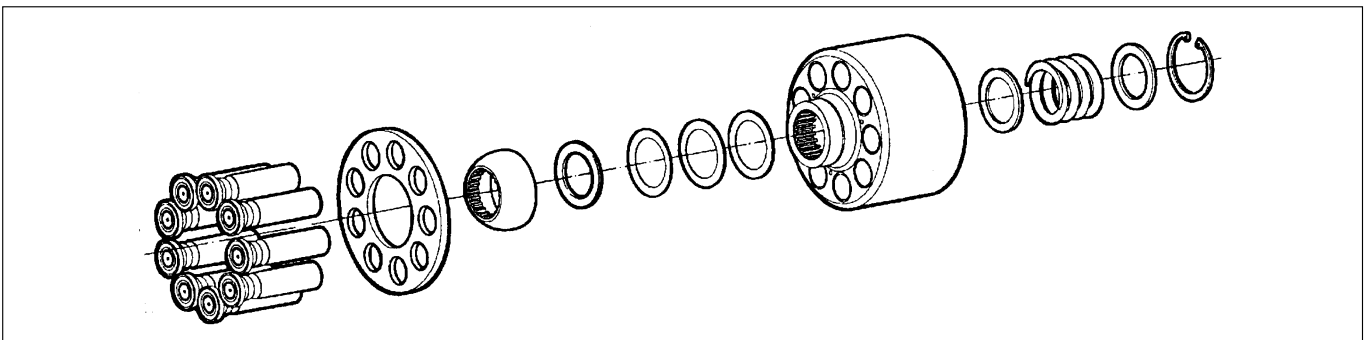

REPAIRS

MOTOR A2FE

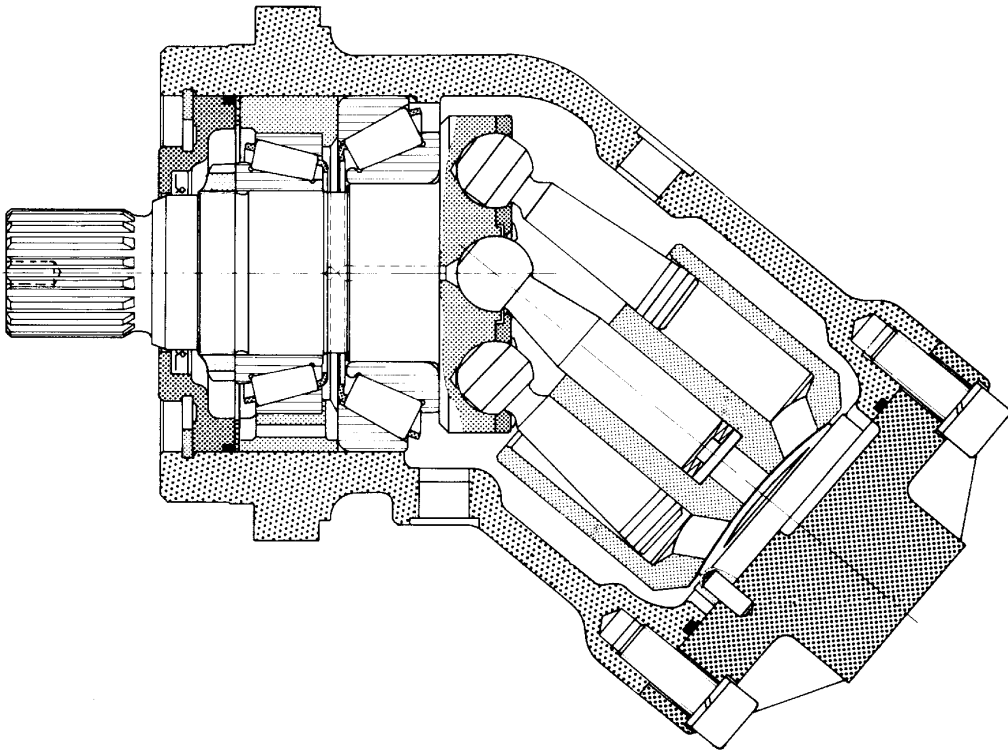

FITTING THE ROTOR

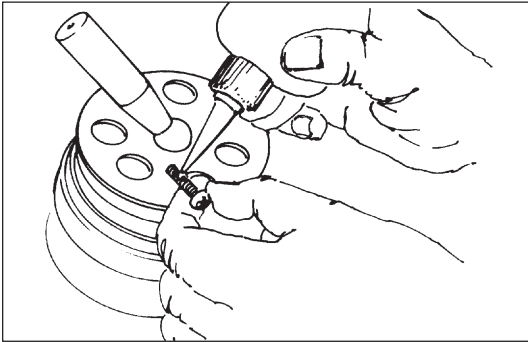

- 36** Apply a small amount of Loctite to the screws only.

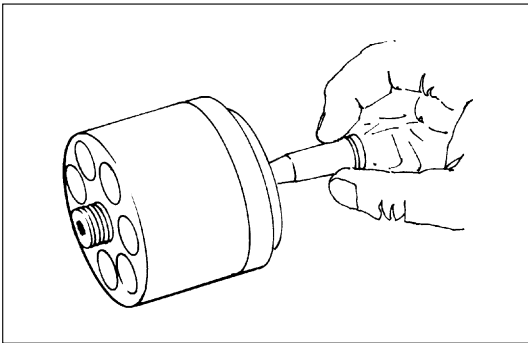

- 37** Assemble the shoes and the Belleville washers with grease (use a screwdriver).

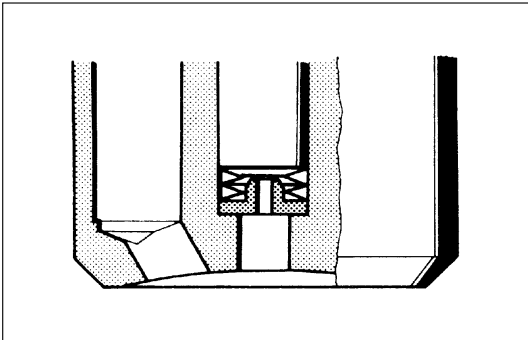

- 38** Ensure that all parts are correctly fitted.

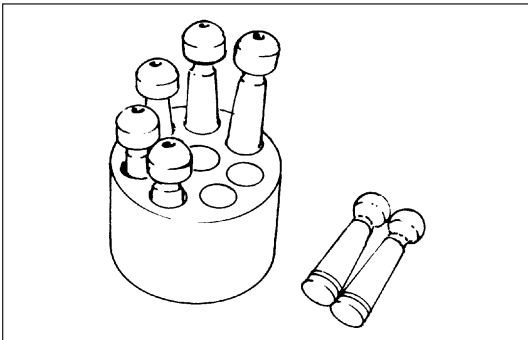

- 39** Fit the pistons.

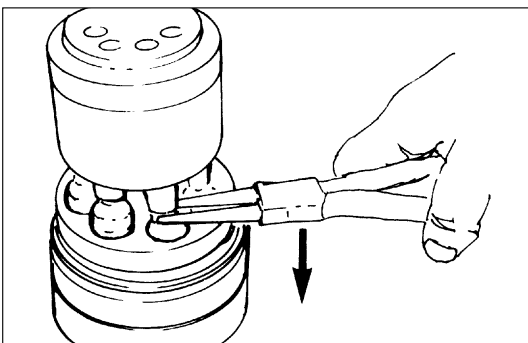

- 40** Press the pistons firmly into the collars with the cylinder block held centrally.

MSI 20 G BUGGIE
MSI 25 G BUGGIE
MSI 30 G BUGGIE

HYDROSTATIC TRANSMISSION CIRCUIT

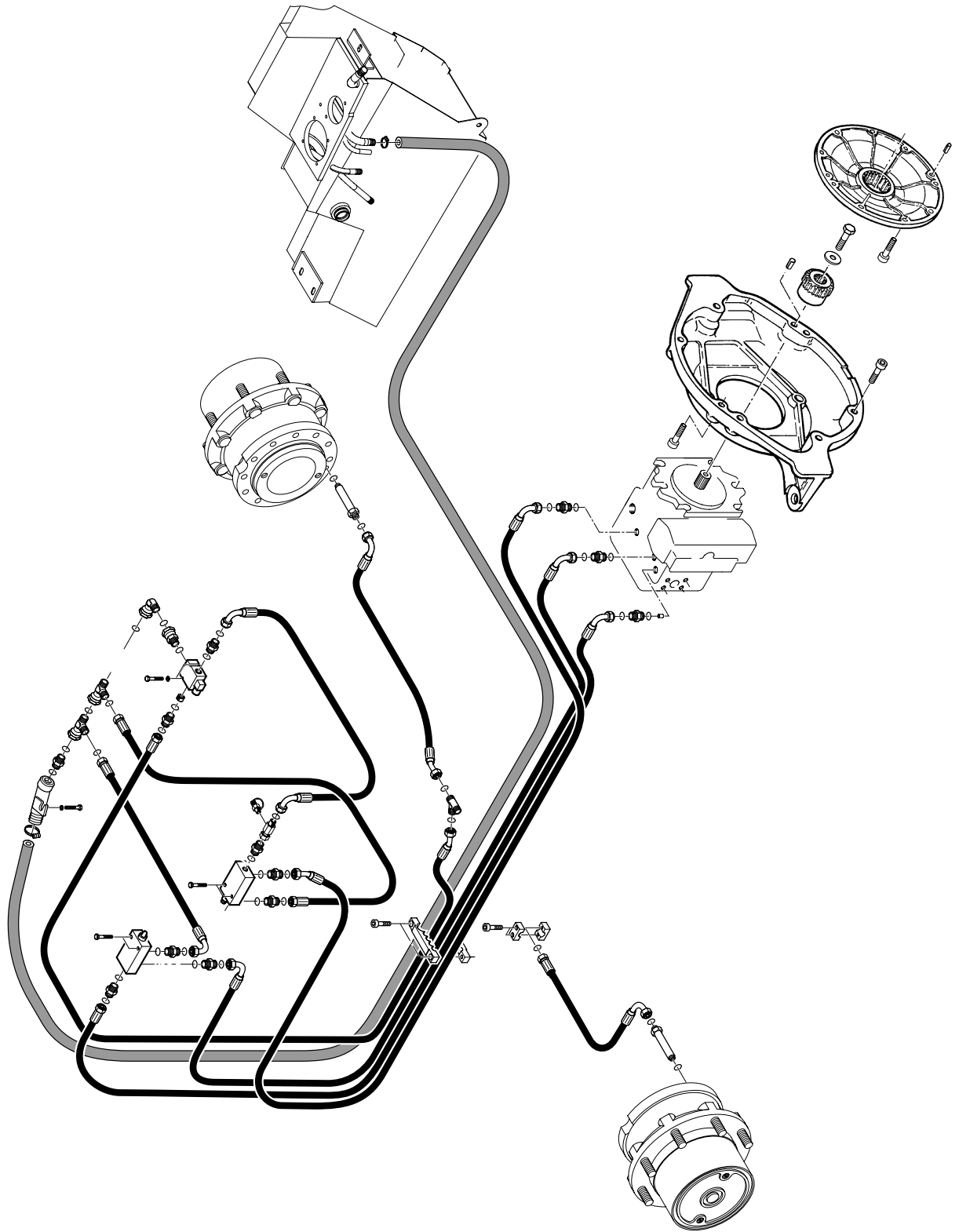

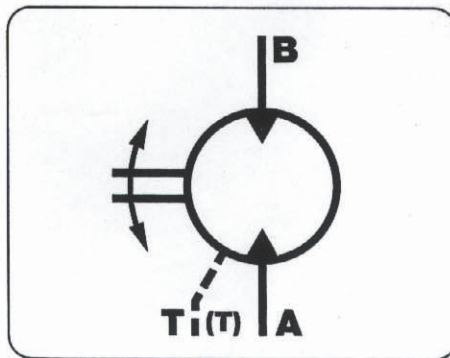
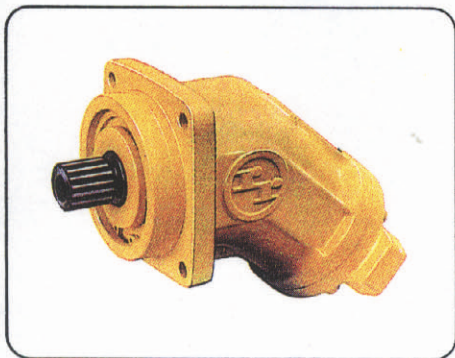

MANNESMANN REXROTH

Hydromatik
Brueninghaus Hydraulik

A2FM
Moteur à cylindrée fixe

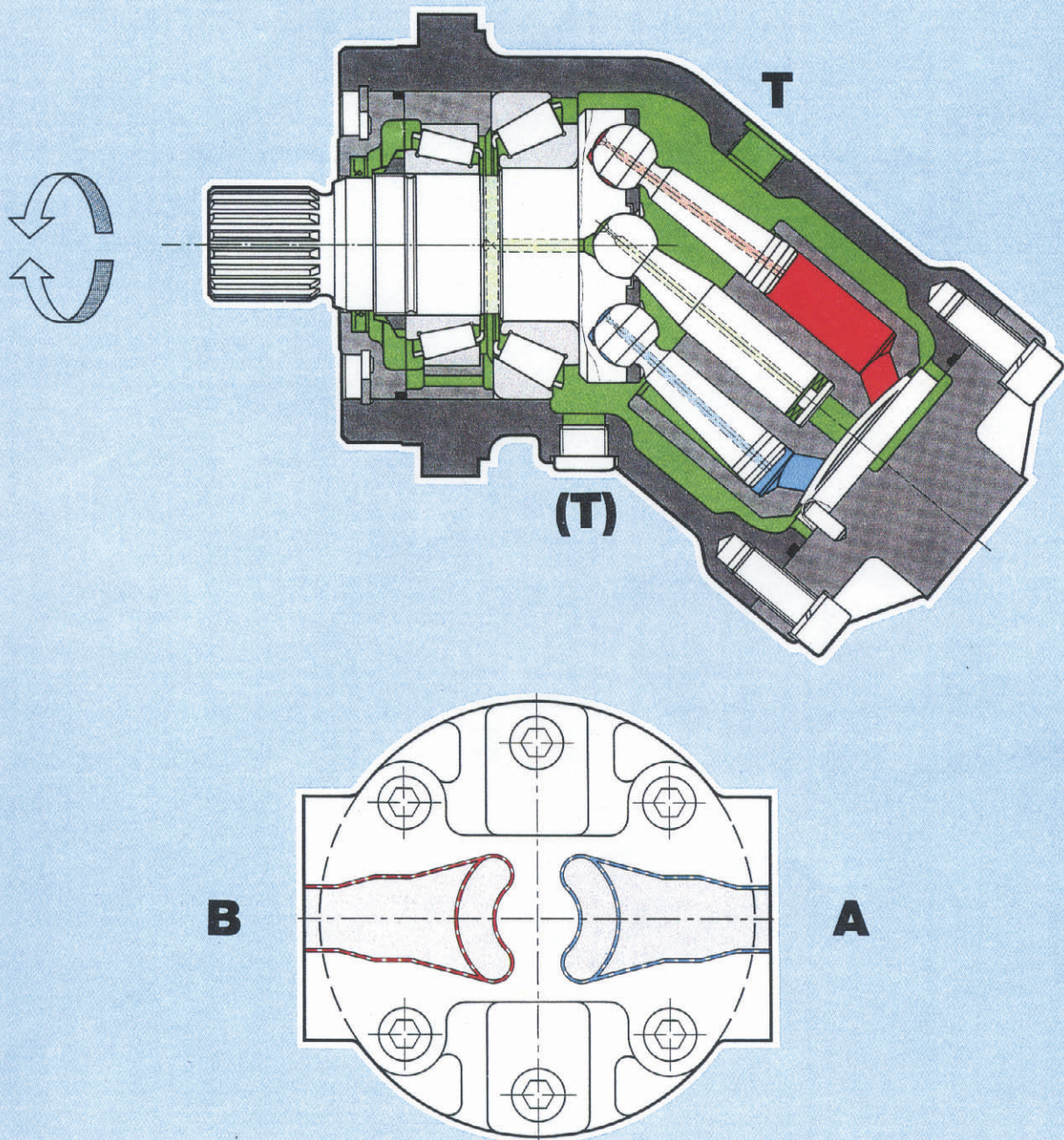

Hochdruck High Pressure Haute pression Alta pressione Alta presión	Högtryck высокое давление ciñnienie wysokie 高 圧 ضغط عالٍ	Niederdruck Return Line Pressure Basse pression Bassa pressione Baja presión	Lågtryck низкое давление ciñnienie niskie 低 圧 ضغط واطئ	Saugdruck Suction Pressure Pression d'aspiration Pressione d'aspirazione Presion des aspiration	Sugtryck давление всасывания ciñnienie ssania 吸 油 口 压 力 ضغط السحب	Lecköldruck Case Drain Pressure Pression de drainage Pressione di trafilamento Presion de drenaje	Dräneringstryck давление утечки ciñnienie odprowadzania przecieków 泄 油 口 压 力 ضغط الزيت المسرب	Steuerdruck Pilot Pressure Pression de pilotage Pressione di pilotaggio Presion de pilotaje	Styrtryck управляющее давление ciñnienie sterowania 操 制 压 力 ضغط التحكم	Stelldruck Control Pressure Pression de commande Pressione di posizionamento Presion de taraje	Ställtryck установочное давление ciñnienie nastawcze 操 制 压 力 ضغط التنظيم
---	--	--	--	---	--	--	--	---	---	--	---

Pressure relief valve adjustment :

- Remove the lead seal A.
- Take off the cap B.
- Loosen the locknut D.
- Adjust the screw E to increase the pressure.
- Refit the cap having installed a new lead seal.

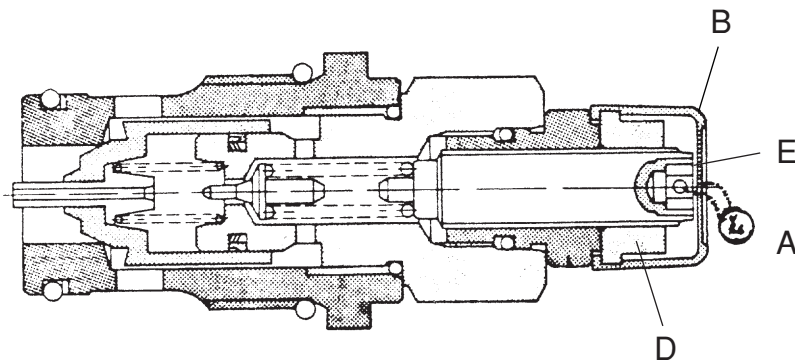

ADJUSTING THE PEDALS AND TH7 VALVES ON MSI 20 G
MSI 25 G
MSI 30 G

FIG. 2 :

- Adjust the screw 03 for secure a dimension $E=6\text{mm}$ (brake pedal released).
- Tighten the locknut 02.
- Adjust the proximity detector 37 for secure a dimension $B=3\text{mm}$
- Tighten the locknut 02.

FIG. 3 :

- Adjust the braking boss 06. Dimension $C =$ approximately 13 mm (in relation to the TH7 body 16).
- Fine down the adjustment to obtain a pressure reading on the gauge of 25 to 30 bar (engine idling speed $900 \pm \begin{smallmatrix} 50 \\ 0 \end{smallmatrix}$ rpm).
- Tighten the locknut 17.

FIG. 2

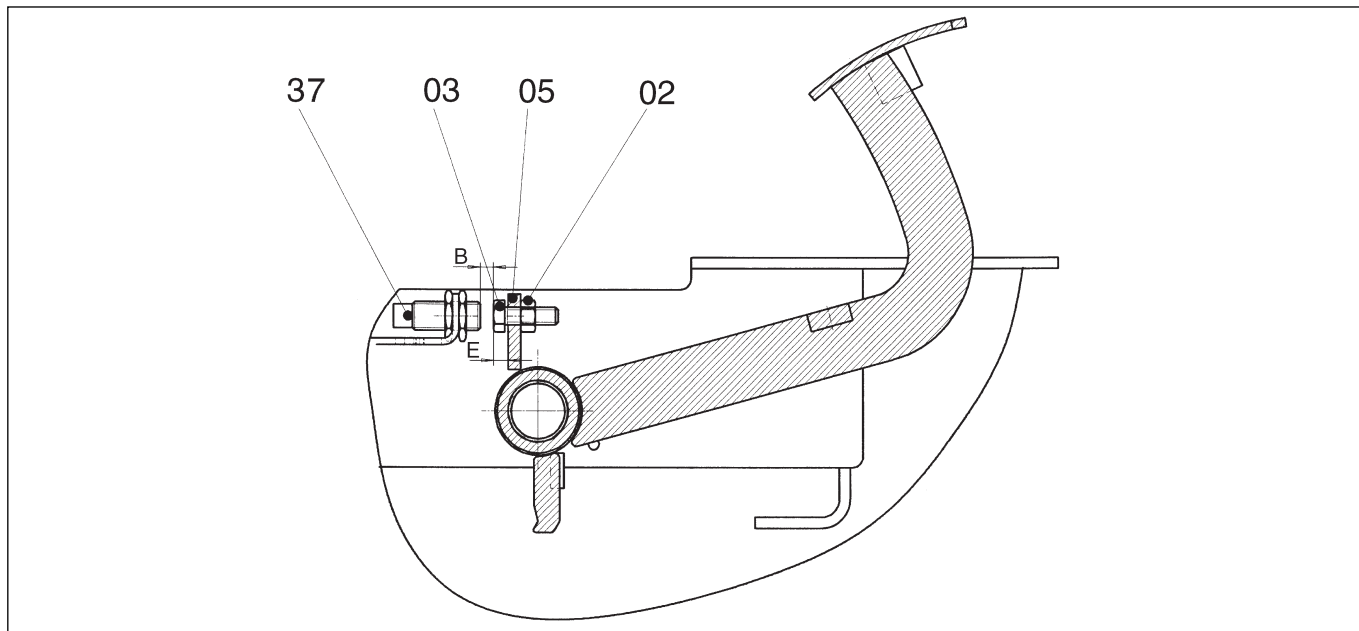
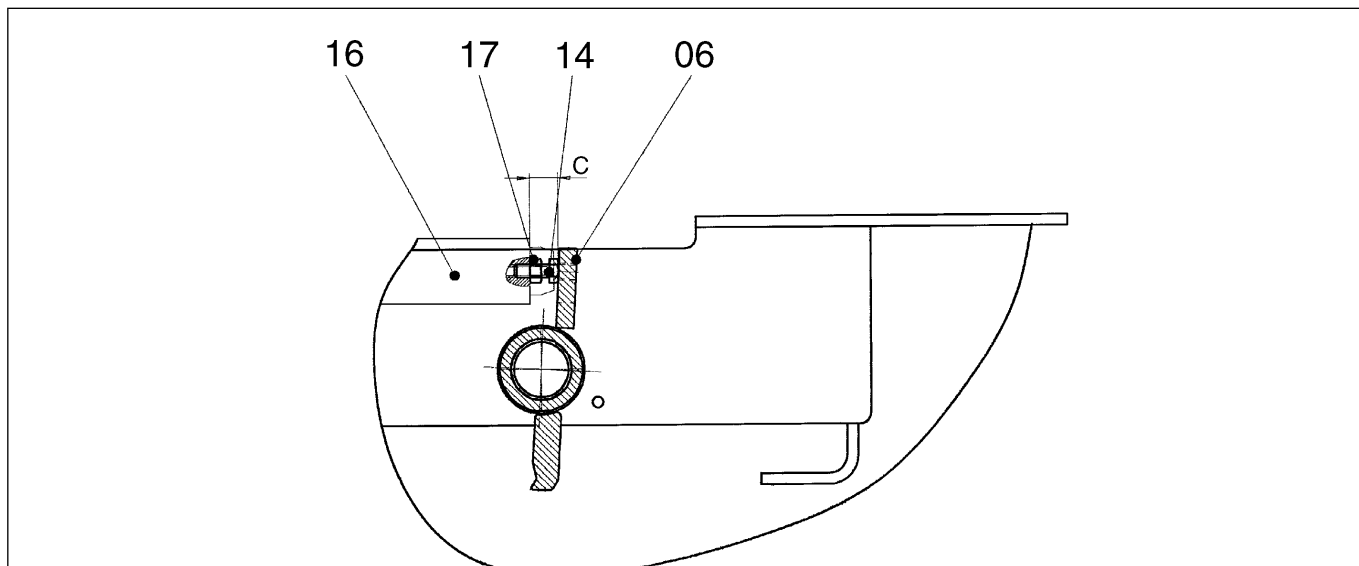

FIG. 3



CLICK HERE TO **DOWNLOAD** THE COMPLETE MANUAL

- Thank you very much for reading the preview of the manual.
- You can download the complete manual from: www.heydownloads.com by clicking the link below



- Please note: If there is no response to CLICKING the link, please download this PDF first and then click on it.

CLICK HERE TO **DOWNLOAD** THE COMPLETE MANUAL