



647428EN (11/12/2019)

MRT 1440 EASY 400 ST3B S1

MRT 1640 EASY 400 ST3B S1

MRT 1840 EASY 400 ST3B S1

MRT 1840 EASY 360 ST3B S1

REPAIR MANUAL

CLICK HERE TO **DOWNLOAD** THE COMPLETE MANUAL

- Thank you very much for reading the preview of the manual.
- You can download the complete manual from: www.heydownloads.com by clicking the link below



- Please note: If there is no response to CLICKING the link, please download this PDF first and then click on it.

CLICK HERE TO **DOWNLOAD** THE COMPLETE MANUAL

00.2 GENERAL CHARACTERISTICS AND SPECIFICATION

00.2.1 CHARACTERISTICS MRT 1440

Designation		Value
Truck weight with standard equipment (Forks)		12825 Kg
Ground distribution with standard equipment (Forks)	Front axle	5575 Kg
	Rear axle	7250 Kg
Overall width		2,40 m
Overall height		2,97 m
Overall length (without forks)		5,34 m
Ground clearance		0,34 m
Pulling force		8600 daN

DIMENSIONS

#	mm	in
A	1200	47,24
A1	150	5,91
A2	1320	51,97
A3	50	1,97
B	290	11,42
C	5060	199,21
C1	5350	210,63
D	1015	171,26
E	2320	39,96
F	1015	91,34
G	340	39,96
H	2375	13,39
I	2970	93,50
J	2040	116,93
K	1930	80,31
L	2400	75,98
M	3720	94,49
N	3980	146,46
O	160	156,69
P	3900	6,30
Q	3410	153,54
R	3951	134,25
S	4301	155,55
S1	3600	169,33
T	5520	141,73
U	950	217,32
V	950	37,40
Y	12°	
Z	105°	

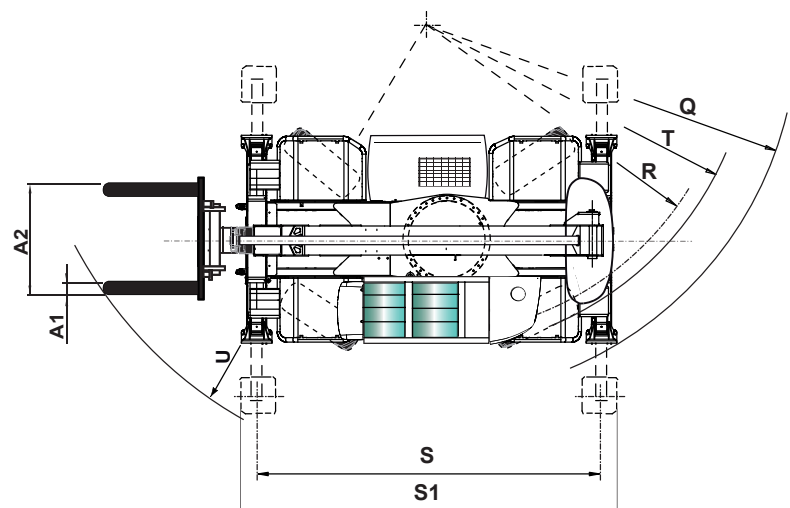
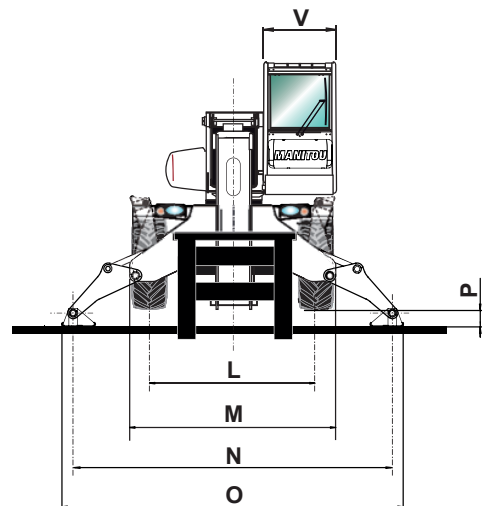
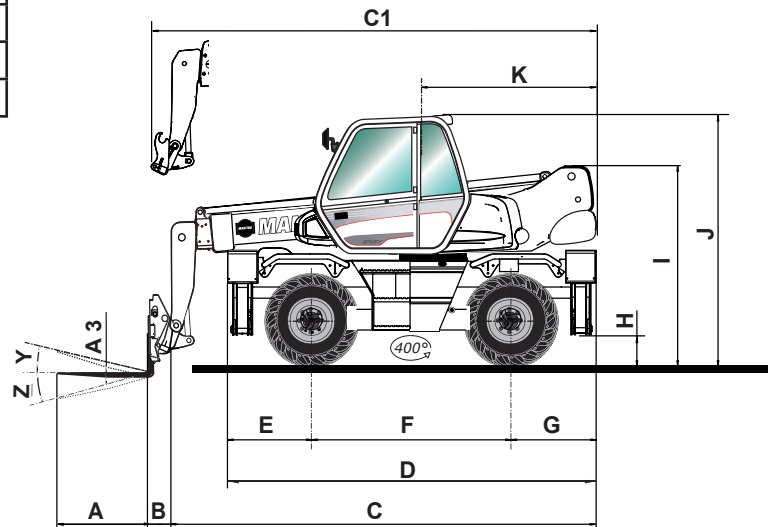
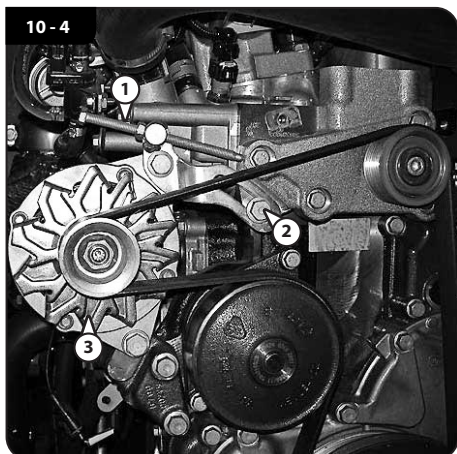









TABLE OF CONTAINS

10.1	POSITION OF THE ENGINE COMPONENTS	23
10.1.1	ENGINE COMPONENTS	23
10.1.2	WATER + AIR COOLING CIRCUIT	25
10.1.3	INTAKE AND EXHAUST	26
10.1.4	HYDRAULIC OIL COOLING CIRCUIT	27
10.1.5	FUEL CIRCUIT.....	28
10.2	CHECKING AND ADJUSTING THE ENGINE	29
10.2.1	POSITION OF THE COMPONENTS	29
	<i>PREPARATION AND SAFETY INSTRUCTIONS</i>	29
	<i>A - REMOVING THE ALTERNATOR BELT</i>	30
	<i>B - REMOVING THE ALTERNATOR</i>	32
	<i>C - REMOVING THE STARTER MOTOR</i>	33
	<i>D - REMOVING THE EGR VALVE</i>	34
	<i>E - REMOVING THE INJECTORS</i>	35
	<i>F - REMOVING THE ENGINE COOLING WATER PUMP</i>	36
10.2.2	ENGINE TIGHTENING TORQUE	37
	<i>ASSEMBLING THE ENGINE</i>	37
10.3	REMOVING THE ENGINE	38
	<i>GENERAL INFORMATION</i>	38
	<i>PREPARATION AND SAFETY INSTRUCTIONS</i>	38
	<i>SPECIFIC TOOLING</i>	38
10.3.1	REMOVING THE ENGINE	39

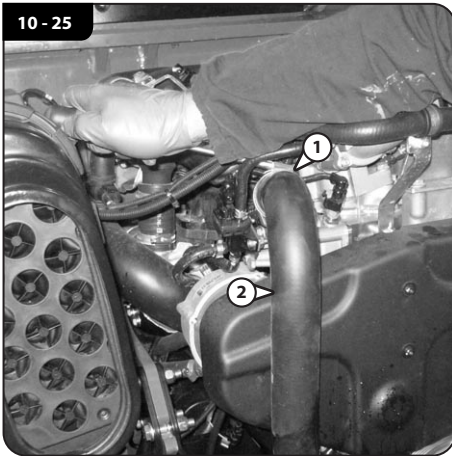




Unscrew the belt tensioner screw (1,  10-4).
Slacken the screws (2,  10-4) to free the alternator (3,  10-4).

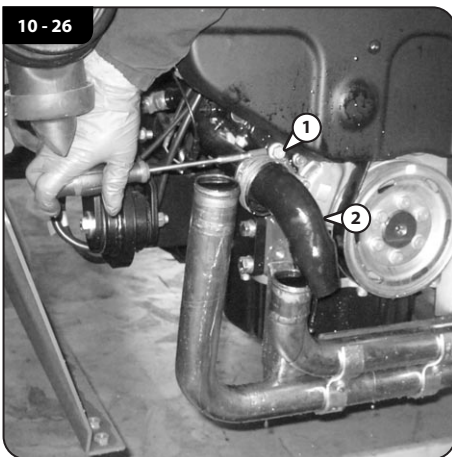




Turn the alternator (1,  10-5) to slacken and remove the belt (2,  10-5).

To reassemble, repeat the operation in reverse order.





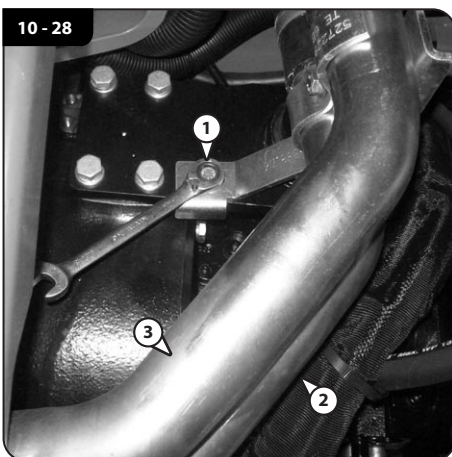
Slacken the clamp (1,  10 - 25) and remove the hose (2,  10 - 25) from the engine.



Slacken the clamp (1,  10 - 26) and remove the hose (2,  10 - 26) from the engine.



Slacken the screws (1,  10 - 27) which secure the iron tubes (2, 3,  10 - 28) on the front of the engine.





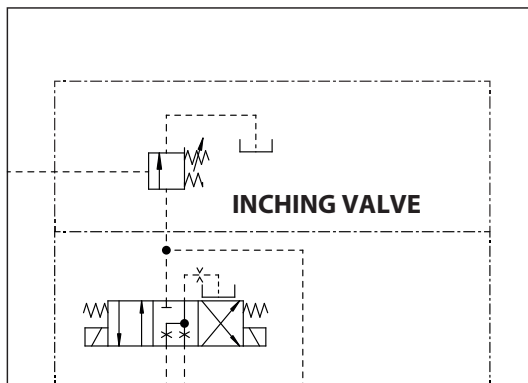
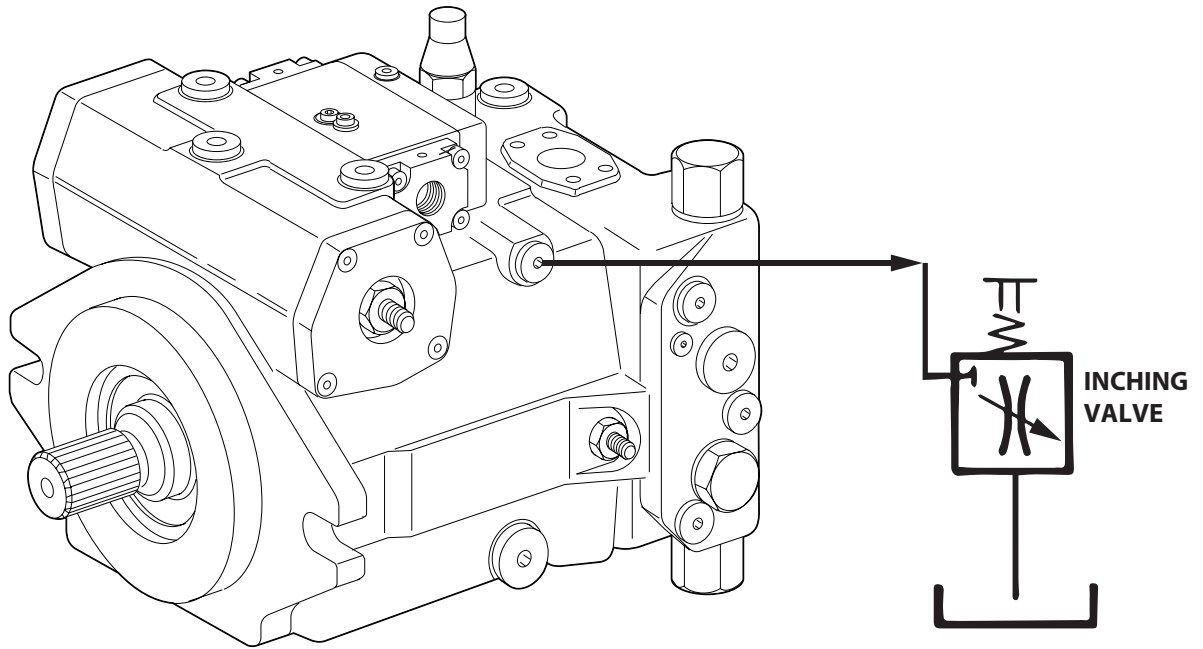
Slacken the screws (1,  10 - 28) which secure the iron tubes (2, 3,  10 - 28) on the rear of the engine.

TABLE OF CONTENTS

20.1	FEATURES AND TECHNICAL SPECIFICATIONS OF THE TRANSMISSION	53
20.1.1	REXROTH HYDROSTATIC TRANSMISSION	53
	<i>SPECIFIC ADVANTAGES OF HYDROMATIC TRANSMISSIONS</i>	53
20.1.2	MAIN CIRCUIT OF HYDROSTATIC TRANSMISSIONS	54
20.1.3	DESCRIPTION OF THE WORKING OF THE A4 VG..DA/A6 VM..DA HYDROMATIC TRANSMISSION	55
	<i>GENERAL INFORMATION</i>	55
20.1.4	TRANSMISSION KINEMATIC CHAIN	56
20.1.5	HYDROSTATIC TRANSMISSION	57
20.1.6	TRANSMISSION HYDRAULIC SYSTEM	57
	<i>A4 VG / 56 DA / 18 PUMP</i>	58
	<i>A4 VG / DA PUMP SECTION</i>	59
20.1.7	WORKING OF THE "DA" CONTROL CARTRIDGE	60
20.1.1	INCHING CIRCUIT	61
20.1.8	DR VALVE	62
	<i>ROLE</i>	63
	<i>OPERATION</i>	63
	<i>CROSS-SECTION VIEW OF DR VALVE</i>	64
	<i>A6 VM / DA ENGINE</i>	65
20.2	TRANSMISSION LAYOUTS	67
20.2.1	HYDROSTATIC TRANSMISSION LAYOUT - FORWARD MOVEMENT	67
20.2.2	HYDROSTATIC TRANSMISSION LAYOUT - REVERSING MOVEMENT	68
20.3	POSITION OF THE TRANSMISSION COMPONENTS	69
20.3.1	HYDROSTATIC TRANSMISSION CIRCUIT	69
20.4	CHECKING AND ADJUSTING THE TRANSMISSION	71
20.4.1	A 4 VG - A 6 VM TRANSMISSION	71
	<i>CHECKS BEFORE STARTING UP THE TRANSMISSION OR AFTER A REPAIR</i>	71
	<i>STARTING UP</i>	71
20.4.2	TRANSMISSION ADJUSTMENT POINTS	72
	<i>A 4VG PUMP</i>	72
	<i>A 6VM ENGINE</i>	72
20.4.3	CHECKING AND ADJUSTING THE TRANSMISSION	73
	<i>CHECKING AND ADJUSTING THE BOOST PRESSURE</i>	73
	<i>ADJUSTING THE PUMP MECHANICAL "0"</i>	74
	<i>CHECKING AND ADJUSTING THE BEGINNING OF THE CONTROL</i>	75
	<i>CHECKING AND RECORDING THE END OF ADJUSTMENT</i>	76
	<i>CHECKING AND ADJUSTING THE HP LIMITERS</i>	77



20.1.1 INCHING CIRCUIT



20.4 CHECKING AND ADJUSTING THE TRANSMISSION

20.4.1 A 4 VG - A 6 VM TRANSMISSION

CHECKS BEFORE STARTING UP THE TRANSMISSION OR AFTER A REPAIR

- Check the oil level in the tank.
- Check to ensure that all the connections of the hose pipes are tightened properly.
- Check the electrical connections of the solenoid valves.
- Ensure that the circuit is filled properly, and at the same time fill the oil filter before fitting it.
- Check to ensure the control air tubes are fitted correctly:
 - X1 pump with X2 motor,
 - X2 pump with X1 motor.
- In all the cases, the control air connection is opposite to the HP hose pipes. (For example: if the HP hose pipe for forward movement is to the RH of the motor, the forward movement control air hose pipe will be to the LH, and the other way around for the reversing).
- Connect the boost pressure socket pressure gauges - control air - HP - casing.

STARTING UP:

- For reasons of safety, place the vehicle on stands.
- Let the I.C. engine run without moving the vehicle to bleed the circuit properly. (disconnect the wire of the stop solenoid valve on the injection pump).
- Make sure that the boost pressure increases at least to 15 bar on running the starter motor.

"DO NOT start up the transmission with insufficient boost pressure, as there is risk of wear of the transmission".

- Reconnect the stop solenoid valve on the injection pump.
- Run the I.C. engine for a few minutes at minimum speed. Boost pressure 35 - 40 bar.

Unstability of the needle indicates air intake (emulsified oil in the tank, and cavitation noise of the transmission).

"Inverter in neutral" in the two HP circuit inlets. The pressure is equal to the boost pressure.

- Heat the oil in the circuit by accelerating progressively (keep the hand brake locked to allow measurement of the HP with load blocked).
- When the oil is at a minimum temperature of 50° - 60° check the engine speed: at minimum, at maximum without load. (See technical specifications).

REGULATION OF ENGINE A 6 VM

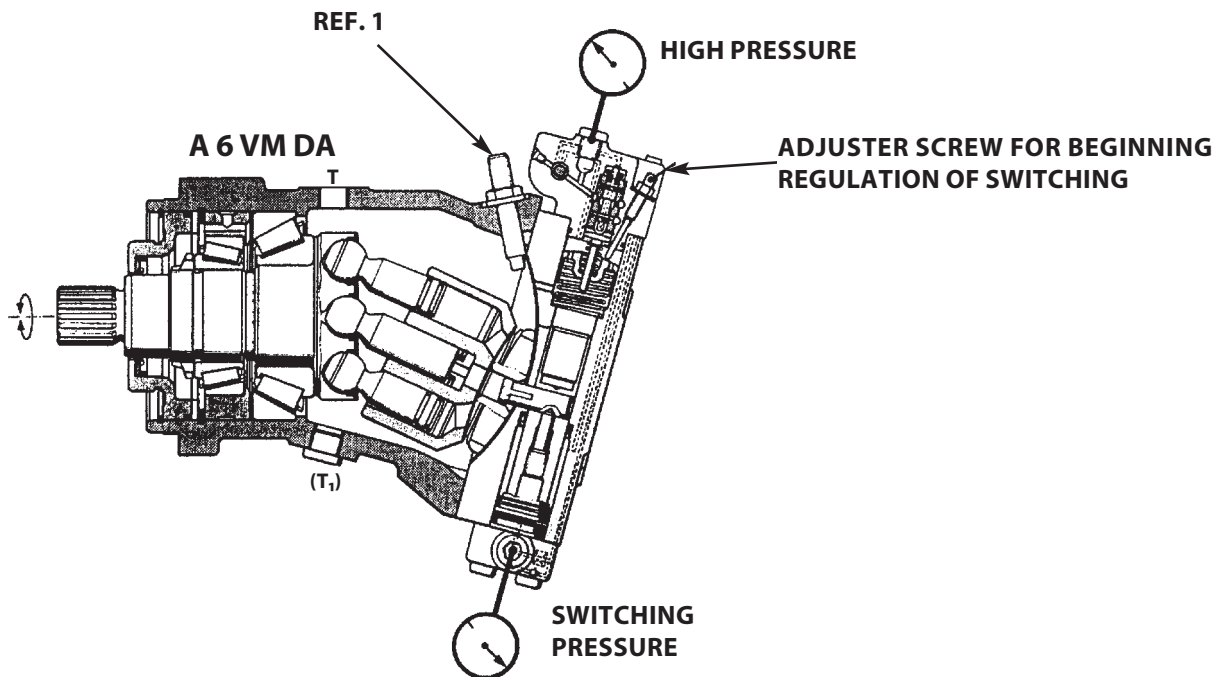
CHECK MINIMUM DISPLACEMENT (MAX SPEED):

- The checking is done with: the truck on level ground, engine running at max. speed, moving forwards,
- Connect the two 600 bar scale pressure gauges as shown in the Figure. At max. vehicle speed, the two pressures must be equal. Taking into account the ratio of the control cylinder surface, this means that the engine is switched in minimum displacement.
- For actual checking of the speed (check the vehicle's technical specifications).

⚠ WARNING

This adjustment (Ref. 1) must be made on the bench by the manufacturer, it must not be changed, except with permission from the Parent Company.

Ref.1 - MINIMUM DISPLACEMENT ADJUSTER SCREW (on tightening the screw the disk moves downwards, the displacement will thus increase while the speed will decrease).






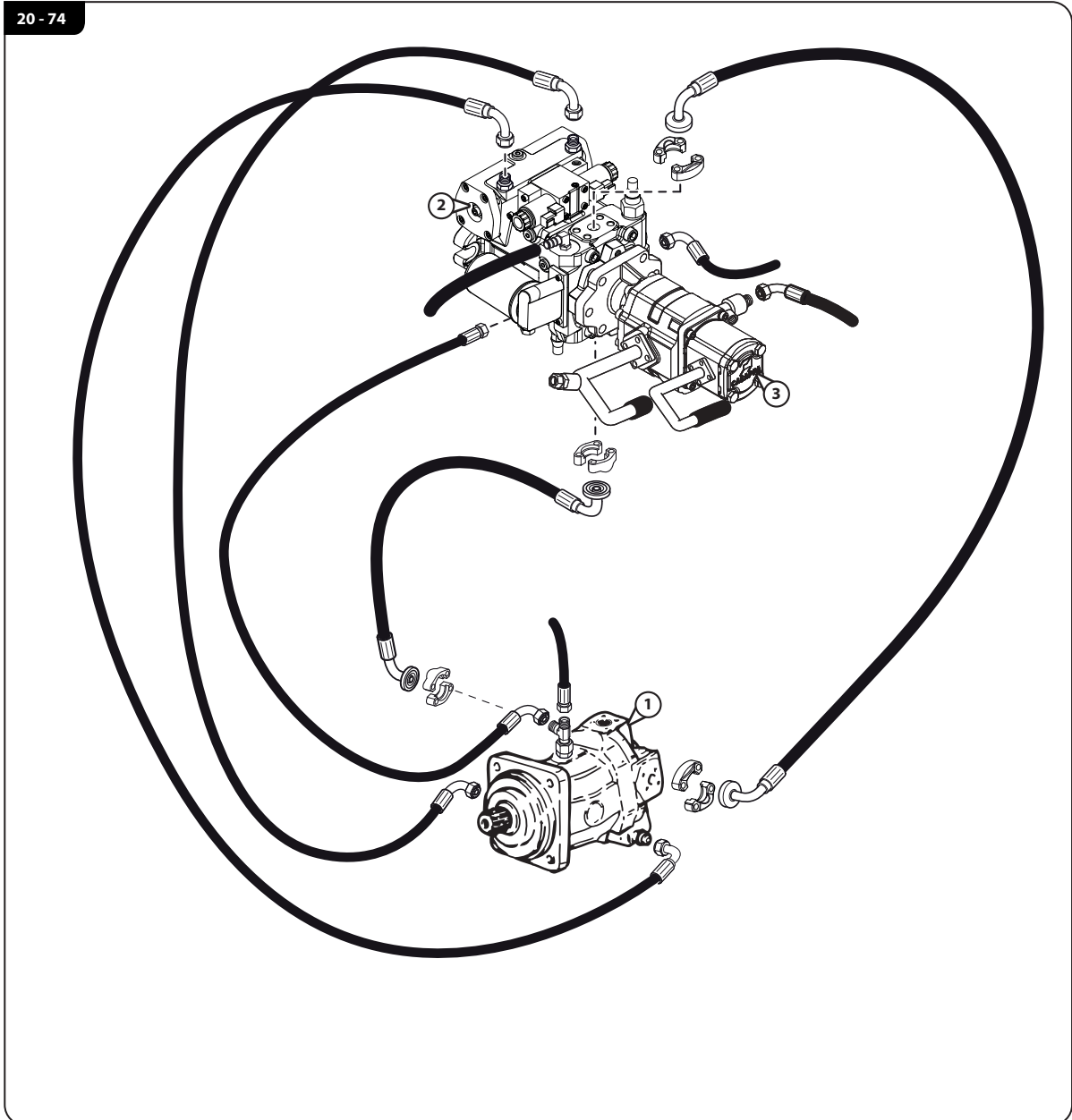
CHECKING THE BEGINNING OF THE ADJUSTMENT

- When the vehicle is at max. speed, press progressively on the brakes to increase the HP (the inching valve must be bypassed).
- Observe the two pressures. When the HP reaches a value of 260 - 280 bar, the switching pressure will drop and the HP will continue to increase up to the DR valve calibration value.
- The initial adjustment of the switching can be set by means of the adjuster screw on the engine.



MAX. DISPLACEMENT (MAX. TRACTION FORCE)

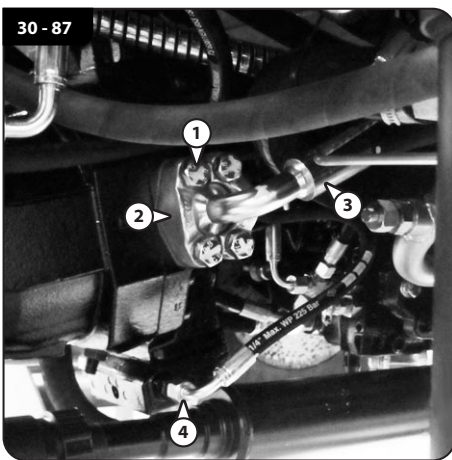
- To make this adjustment, the lift truck must be blocked (brakes locked). The checking is done at max. engine speed with the vehicle moving forwards.
- The switching pressure (greater cross-section side of the control cylinder) must be close to zero bar. If necessary, adjust the adjuster screw (tighten to increase the switching pressure, slacken to decrease the pressure).
- The traction force must be checked (at the hook) (for the values, see Use and Maintenance Manual).









Wash and dry all the pipes of the hydraulic fluid system and suction thoroughly, fit the pipes on the services pump (3,  20 - 14), on the hydrostatic pump (2,  20 - 14) and on the hydraulic motor (1,  20 - 14), taking care to position these correctly back in place according to the markings made with the marker pen in the dismantling phase.

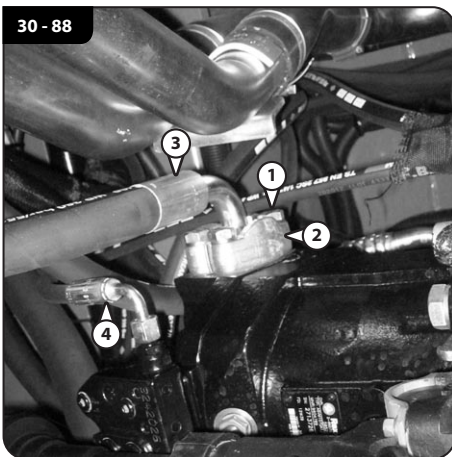




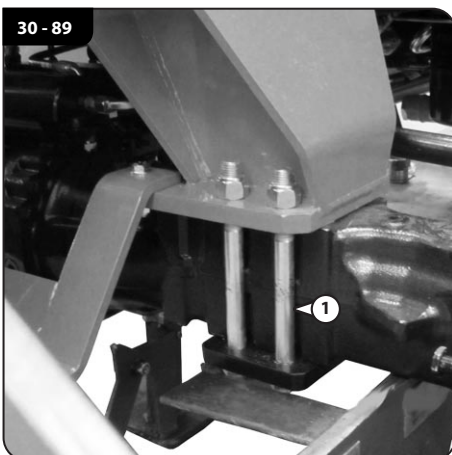
Disconnect the tube (1, ) concerned with the working of the parking brake.
Disconnect the electrical connection (2, ) of the wheels alignment sensor.



Unscrew the connecting screws (1, ) (1, ) of the flange (2, ) (2, ) on the two sides of the hydrostatic motor and disconnect the tubes (3, ) (3, ).
Disconnect the hydraulic tubes (4, ) (4, ).



Disconnect the tubes from the "T" connector above the engine and disconnect the electric wiring from the connector.




Secure the front axle and the hydrostatic motor to an overhead crane or elevator suitable for the weight to be supported.
Slacken the screws (1, ) fixing the front axle to the chassis (on the LH).

TABLE OF CONTAINS

40.1	FEATURES AND TECHNICAL SPECIFICATIONS OF THE BRAKES	113
40.1.1	SERVICE BRAKE	113
40.1.2	PARKING BRAKE	114
40.2	POSITION OF THE BRAKES COMPONENTS	115
40.2.1	THE BRAKES COMPONENTS	115
40.3	CHECKING AND ADJUSTING THE BRAKES	116
40.3.1	BLEEDING THE BRAKES AND ADJUSTING THE INCHING	116
	<i>PREPARATION AND SAFETY INSTRUCTIONS</i>	116
	<i>BRAKES BLEEDING PROCEDURE</i>	117
	<i>DEACTIVATE THE NEGATIVE BRAKE</i>	118
	<i>SETTING THE GEAR IN NEUTRAL (FOR TOWING)</i>	118
	<i>INCHING CONTROL</i>	118
	<i>BRAKES SYSTEM LAYOUT</i>	119
40.4	SPECIAL TOOLS FOR THE BRAKES	121
40.4.1	HYDRAULIC BRAKE VENTING VALVE	121



40.4 SPECIAL TOOLS FOR THE BRAKES

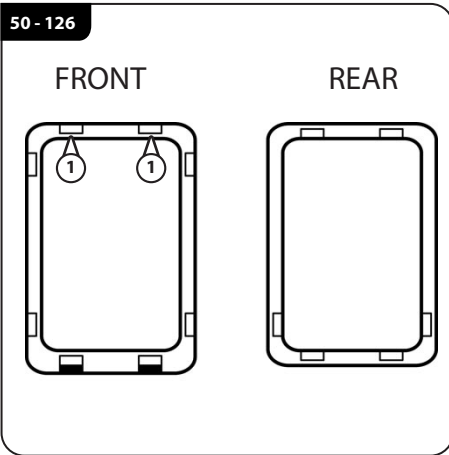
40.4.1 HYDRAULIC BRAKE VENTING VALVE




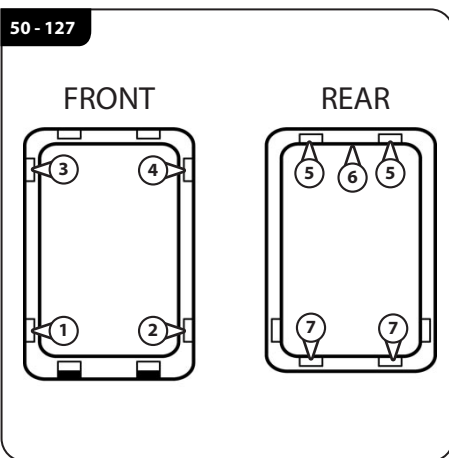
Venting valve complete with components necessary for venting the brakes hydraulic systems for all Manitou products.



MANITOU reference

Hydraulic brake venting valve	554019
Spare parts:	
Maximum pressure gauge	719980
Minimum pressure gauge	719981
Diaphragm	661913
Brake tube	661914






Insert the sliding blocks (1,  50 - 5) in the upper part of the outer boom, in front, using shims if necessary, and block using fixing screws.



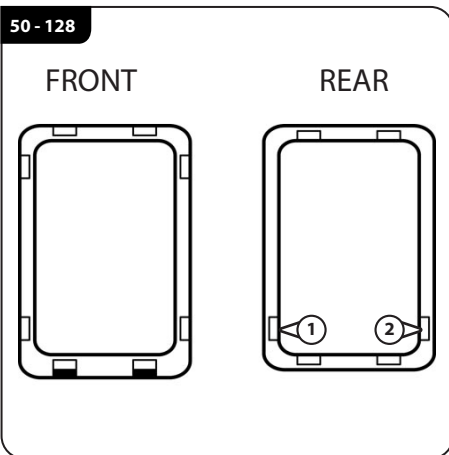
Align the 1st extension boom in relation to the outer boom. Insert the lateral sliding blocks (1,2,  50 - 6) in the front lower part of the 1st extension boom, using shims if necessary, and block. Insert the sliding blocks (3,4,  50 - 6) in the upper part, using shims if necessary, and block.


Note: the shims of the sliding blocks (1, 2, 3, 4,  50 - 6) may be different.

Retract the 1 extension boom in the outer boom completely. Also make sure the two rear upper sliding blocks (5,  50 - 6) of the 1st extension boom adhere perfectly to the upper surface of the outer boom, using shims, if necessary.

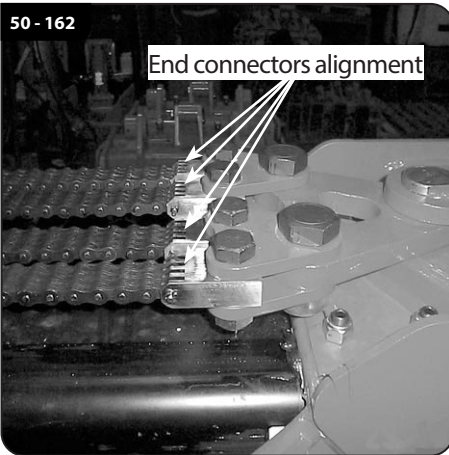
Block the upper part of the telescopic boom with a clamp, on the rear side (6,  50 - 6) to fit the lower sliding blocks (7,  50 - 6), using shims, if necessary.


Block the sliding blocks by means of fixing screws. Remove the clamp.



Align the 1st extension boom in relation to the outer boom. Insert the lateral sliding blocks (1, 2,  50 - 7) in the rear lower part of the 1st extension boom, using shims if necessary, and block.

Note: the shims of the sliding blocks (1, 2,  50 - 7) may be different.

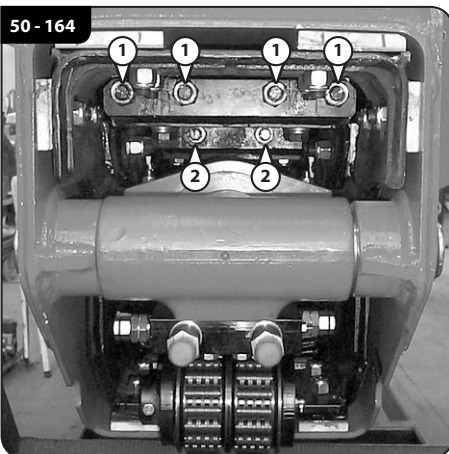
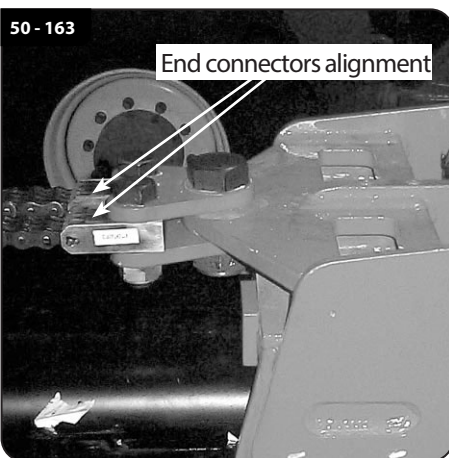


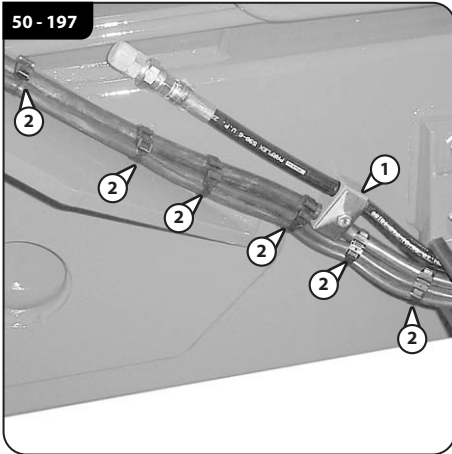
Check to make sure the end connectors of the upper chains are aligned. If this is not the case, act on the nuts of the rear tie-rods (1, 2,  50 - 43).



Tighten all the lock nuts on the chain fixing tie-rods.

Extend the boom completely to grease it along the entire length near the sliding blocks and lubricate the chains (see the "Lubricants" Table in the Use and Maintenance Manual).


Close the boom, leaving it extended by about 10-20 cm.

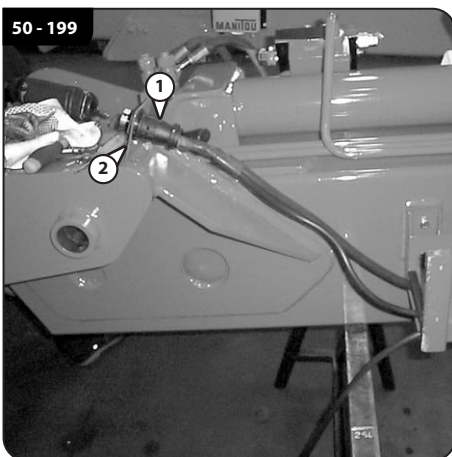







Release the electric cables and hydraulic tube in the rear part of the tubular element by removing the collar (1,  50 - 76) and all the clamps (2,  50 - 76).





Release the electric cables and the hydraulic drainage tube from the sheath (1,  50 - 77).

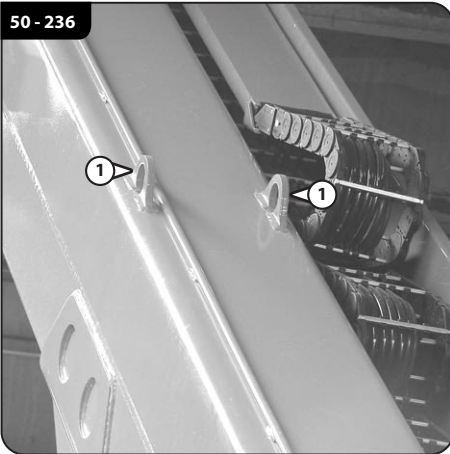



Disconnect the multiple power socket (1,  50 - 78) for the platform from the pinholder plate (2,  50 - 78).

Remove the plate (2,  50 - 78) for the electric socket at the back on the RH of the outer boom.







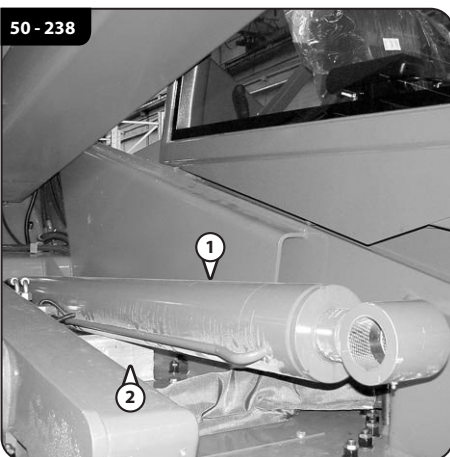
Remove the cables (1,  50 - 79) for the platform socket and the hydraulic tube for drainage (1,  50 - 70) at the top of the boom, completely, from the back of the chainholder tube.





Secure the boom to an overhead crane or an elevator by means of the eyelets provided for the purpose (1,  50 - 115) in the upper part of the boom.



Secure the lift cylinder (1,  50 - 116) to a support. Slacken the stop screw (2,  50 - 116), the nut (3,  50 - 116) and remove the lift cylinder hinge pin (4,  50 - 116) of the rod-boom side.



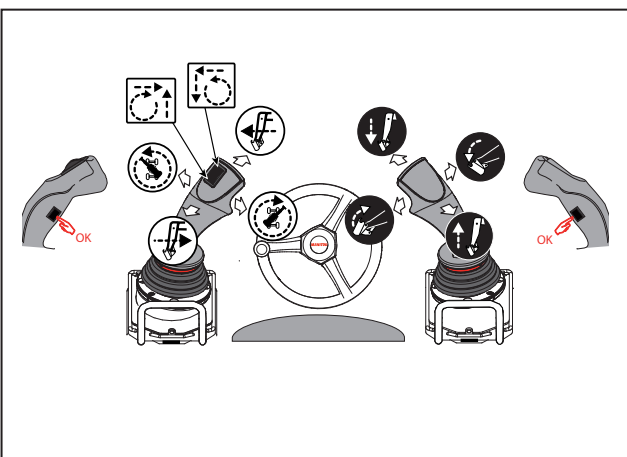
Place the lift cylinder (1,  50 - 117) on the turret, resting it on a wooden beam (2,  50 - 117) and retract the rod using the control in the cab.

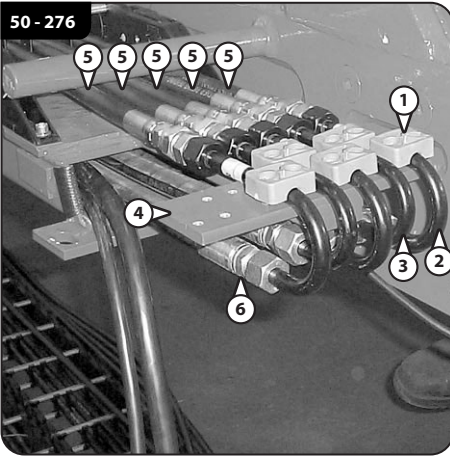
Lower the telescopic boom to an almost horizontal position by acting on the overhead crane or elevator used.




Stop the I.C. engine.





Reactivate the ignition key to position "I" (ignition key-dashboard contact) and carry out all possible movements with the commands to discharge residual pressure from the hydraulic circuit.

Deactivate the ignition key and disconnect the terminals from the battery.

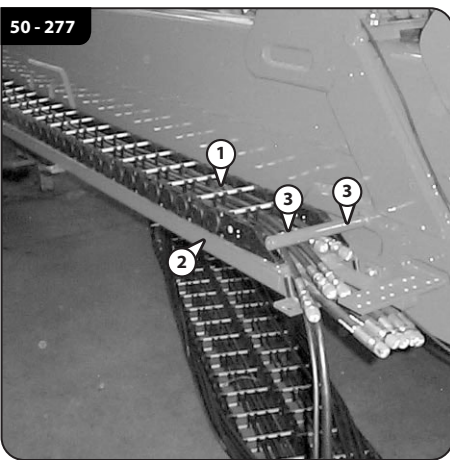







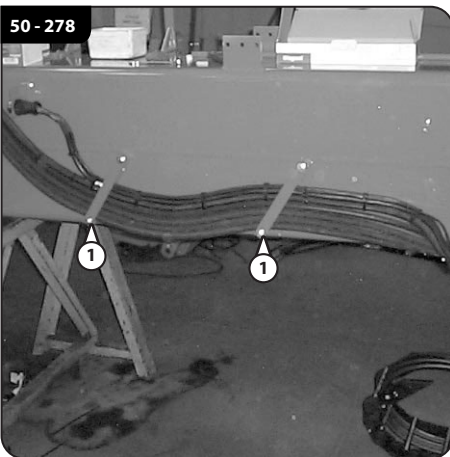
Remove the locking collars (1,  50 - 155) of the iron tubes (2,3,  50 - 155) from the fixing plate on the outer boom chain-holder tube (4,  50 - 155).


Disconnect the iron tubes (2,3,  50 - 155) from the hydraulic pipes (5,  50 - 155) inside the first tube-holder chain; disconnect the iron tubes (2,3,  50 - 155) from the hydraulic pipes (6,  50 - 155) inside the outer boom chain-holder tube.

During this operation, mark the hydraulic tubes for correct reassembly.



Dismantle the first tube-holder chain (1,  50 - 156) from the chain-holder tube (2,  50 - 156) by removing the screws concerned (3,  50 - 156).



Free the hydraulic pipes and electric cables from the outer boom by removing the brackets (1,  50 - 157).



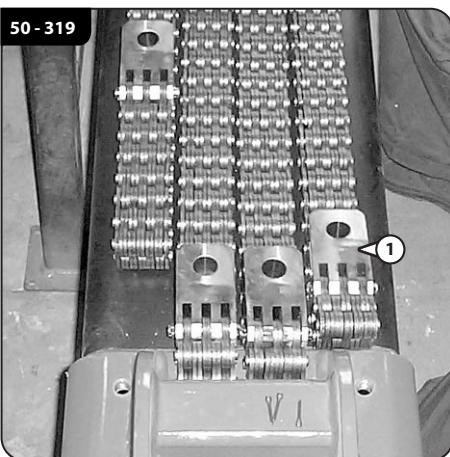
Remove the hydraulic pipes and electric cables from the chain-holder tube.




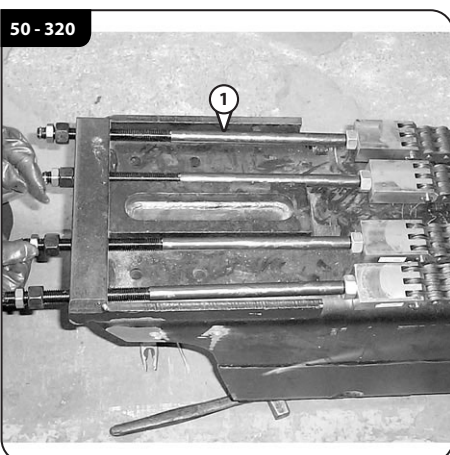
Secure the chains (1,  50 - 196) to the III extension boom.




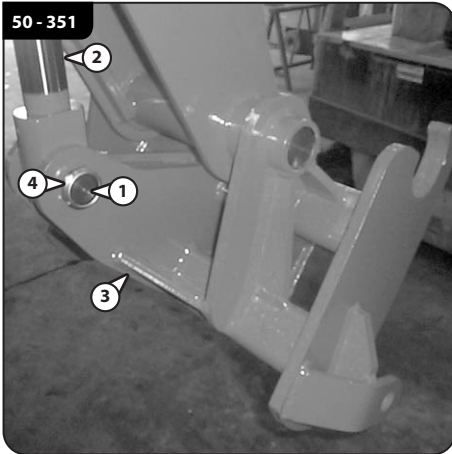
Using an overhead crane or elevator, extend the III extension boom from the II extension boom, keeping the chains resting on the upper part stretched taut, as they can get entangled.








Remove the upper end connectors in the front part of the four chains (1,  50 - 198) for extension of the II extension boom.

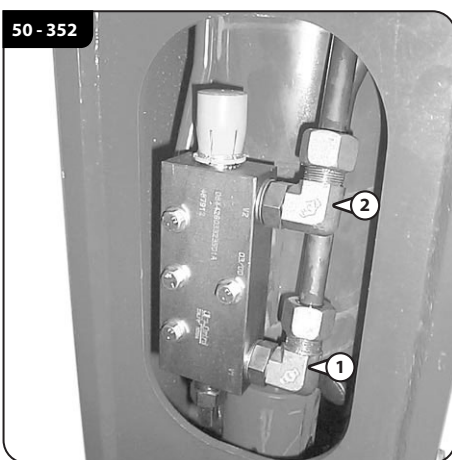



Remove the tier rods (1,  50 - 199) fixing the II extension boom extension chains, through the holes provided at the tail end of the II extension boom.

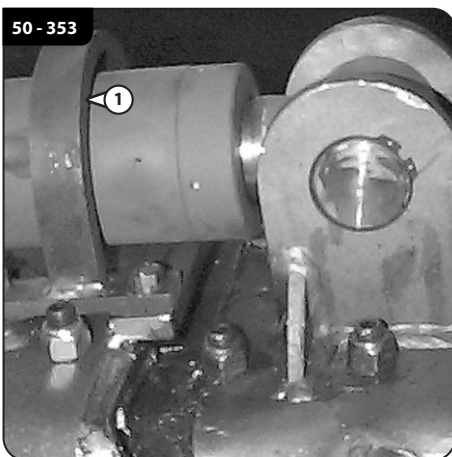


Grease the hinge pin (1, ) 50 - 230) of the rod side of the slewing cylinder (2, ) 50 - 230) with the quick-coupling (3, ) 50 - 230) and insert it in its hole.

Screw the lock nut (4, ) 50 - 230) of the cylinder hinge pin (2, ) 50 - 230).





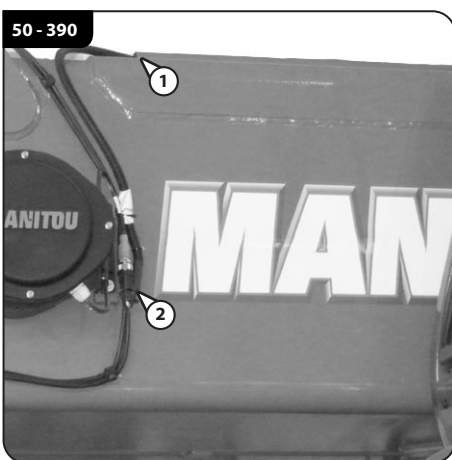
Tighten the unions (1,2, ) 50 - 231) correctly to the valve on the slewing cylinder.





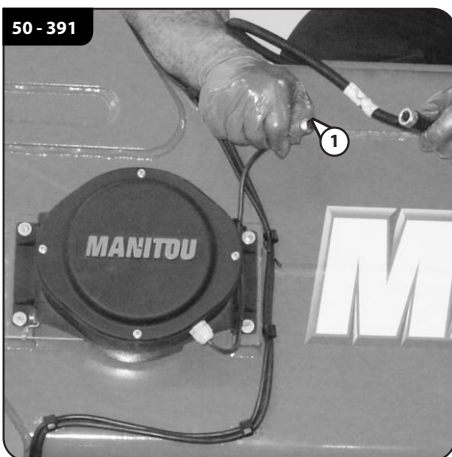
Fit the I extension cylinder cover (1, ) 50 - 232) at the top of the telescopic boom.



Refit the rear cover plate (1,  50 - 268) of the turret by means of the fixing screws (2,  50 - 268).
Remove the cover of the "M.S.S." roll-over protection system cable reel cover.




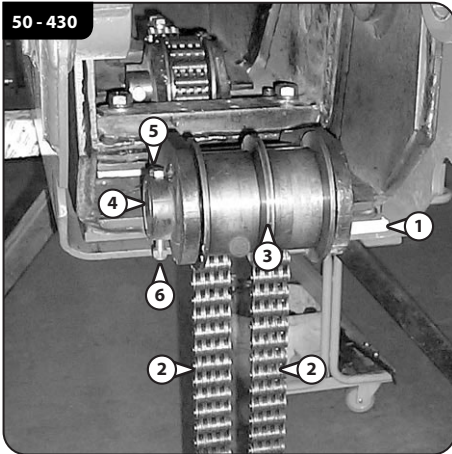
Take the "M.S.S." system roll-over protection connector and insert it completely into the protective metallic tube (1,  50 - 269) present in the upper part of the boom, and refit the clamps (2,  50 - 269).






Reconnect the cable reel connector (1,  50 - 270).






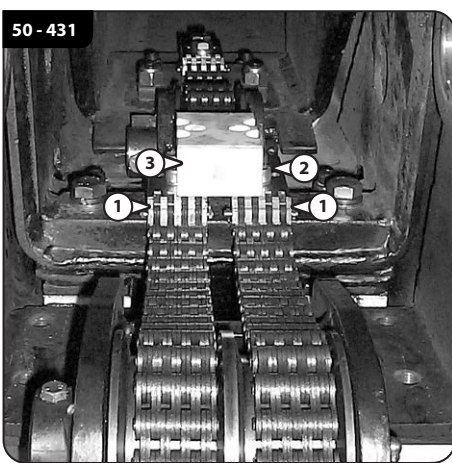
Lift the quick-coupling (1,  50 - 271) using an overhead crane or an elevator and place it in its seat on the boom head.





Lift the I extension boom in the rear part inside the outer boom after placing a sliding block (1,  50 - 309) under it temporarily. The chains (2,  50 - 309) will thus be freed.


Fit the pulley (3,  50 - 309) in the upper rear part of the I extension boom, insert shims to prevent the pulley from rubbing against the boom structural steel frame.

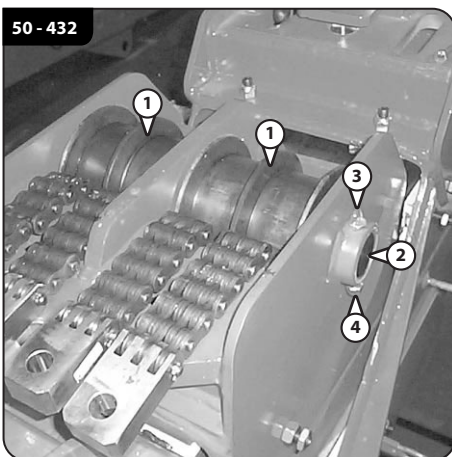
Grease and insert the pin (4,  50 - 309) in the hole concerned and fix it by means of the screw (5,  50 - 309) and the nut (6,  50 - 309).







Fix the end connectors (1,  50 - 310) of the 2 chains to the II extension boom and by means of the screws (2,  50 - 310) on which Loctite threadlock blue 243 must be applied.

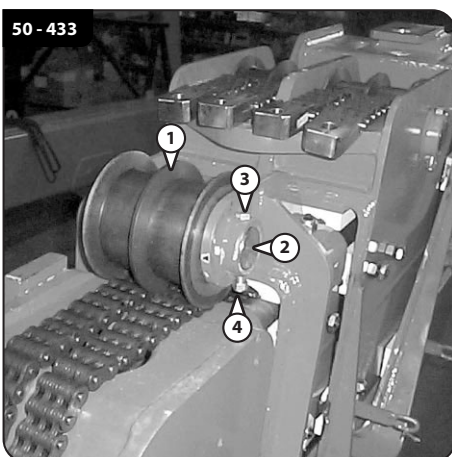
Tighten the screws (2,  50 - 310) using a tightening torque of 70 Nm.


Fit the sliding block (3,  50 - 310) for the sliding of the extension cylinder.






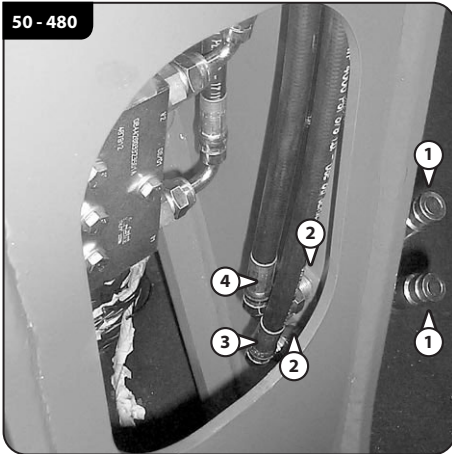
Fit the pulley (1,  50 - 311) in the upper front part of the I extension boom, insert shims to prevent the pulleys from rubbing against the boom structural steel frame.




Grease and insert the pin (2,  50 - 311) in the hole concerned and block it by means of the screw (3,  50 - 311) and the nut (4,  50 - 311).

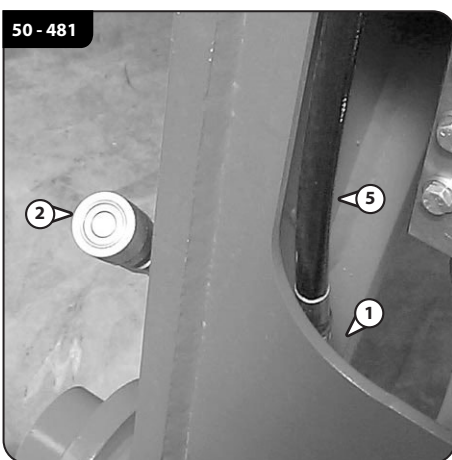





Fit the pulley (1,  50 - 312) in the upper front part of the II extension boom, insert shims to prevent the pulley from rubbing against the boom structural steel frame.

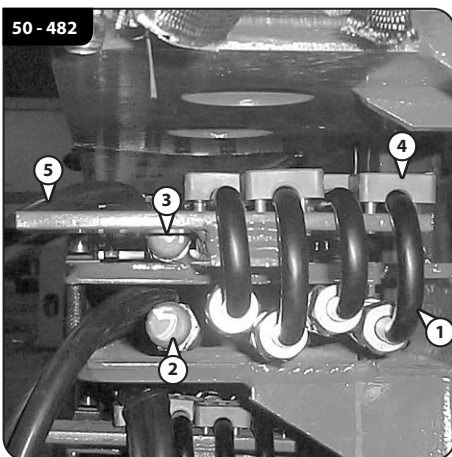
Grease and insert the pin (2,  50 - 312) in the hole concerned and block it by means of the screw (3,  50 - 312) and the nut (4,  50 - 312).








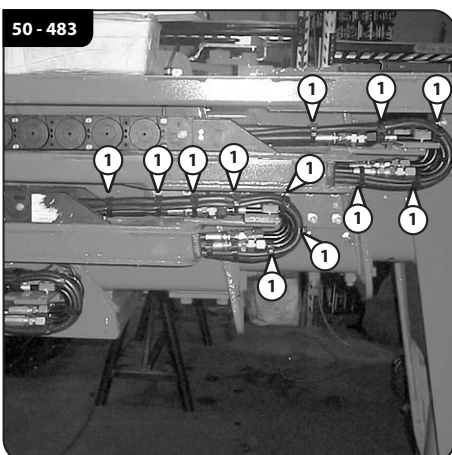
Protect the tubes for the optional accessory deriving from the first tubes numbered (3,4,  50 - 359) with a sheath, insert these into the upper opening at the head of the boom and connect it to the union (2,  50 - 359) of the quick-coupling (1,  50 - 359) on the LH side of the head of the boom.




Protect the drainage tube deriving from the tube numbered (5,  50 - 360) with a sheath, insert it into the upper opening at the head of the boom and connect it to the union (1,  50 - 360) of the quick-coupling (2,  50 - 360) on the RH side of the head of the boom.

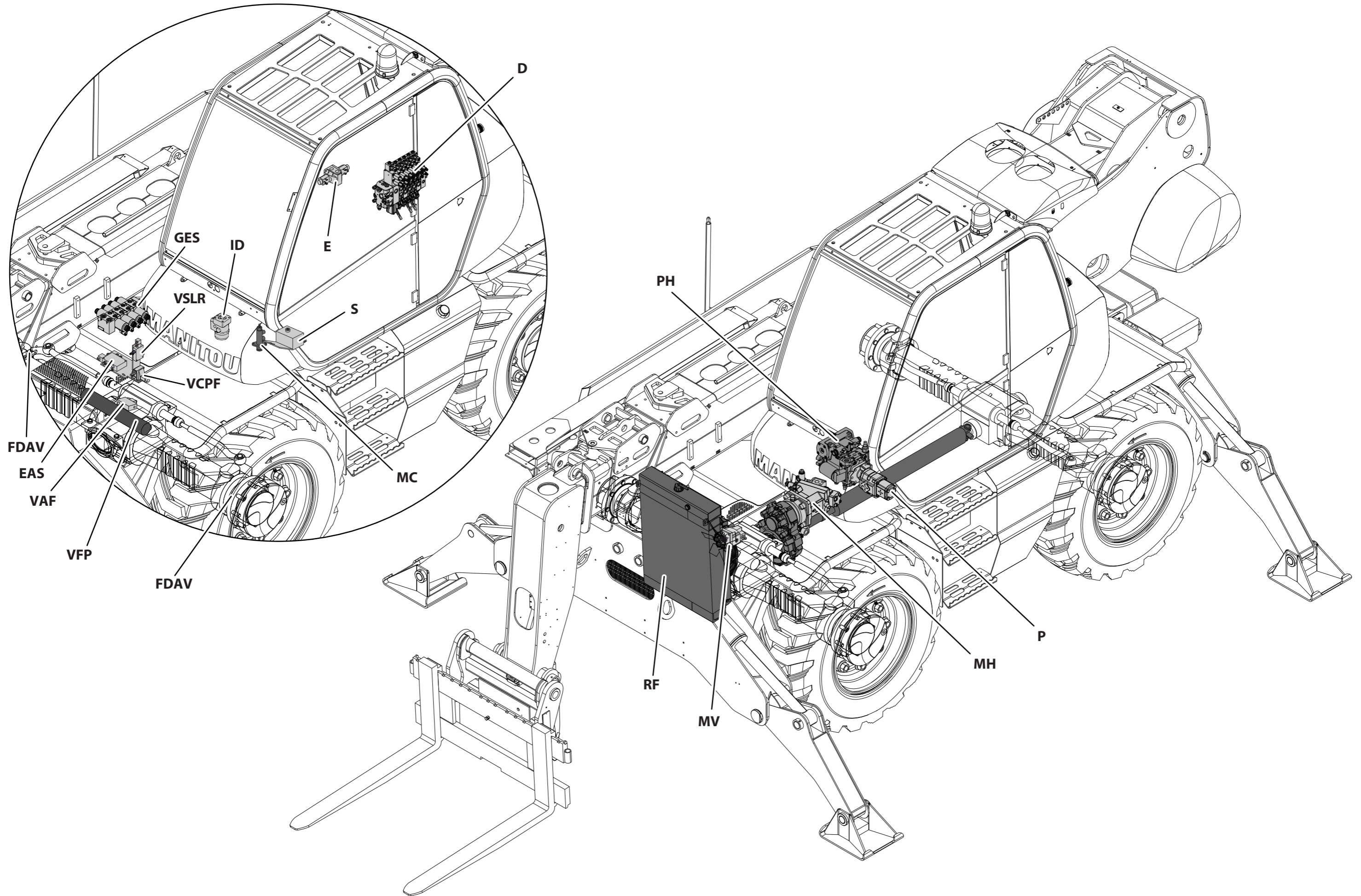


Connect the iron tubes (1,  50 - 361) to the tubes (2,  50 - 361) inside the tubular element and then the tubes (3,  50 - 361) inside the chain by following the sequence from inside the boom towards the outside, alternating the long and short connectors. Fix the connectors with the collars (4,  50 - 361) to the chain-holder tube (5,  50 - 361).



Secure the electric cables to the hydraulic pipes by means of clamps (1,  50 - 362) in the passages between the chain-holder tubes and tube-holder chains.

70.2.1 DIAGRAM 1 - HYDRAULIC COMPONENTS LOCATION





70 - 519



PISTON AND LOCKING NUT



DISASSEMBLY

Hold the rod in a vice fitted with jaw facings, tighten to prevent the unit from rotating.

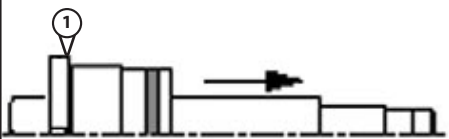
Unlock the nut (1,  70 - 11) and unscrew completely using a polygonal wrench or, depending on the version, remove the screw pin (2,  70 - 11) using a hex wrench.

70 - 520



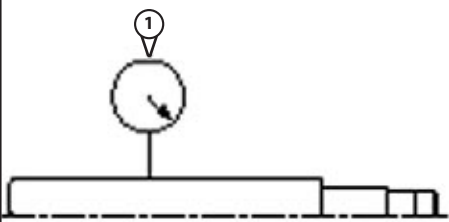
Remove the piston (1,  70 - 12) by pulling it out manually or, depending on the model, unscrewing the piston (1,  70 - 12) with the help of a pin spanner.

70 - 521




Remove the ring nut (1,  70 - 13) by sliding it along the rod.

70 - 522



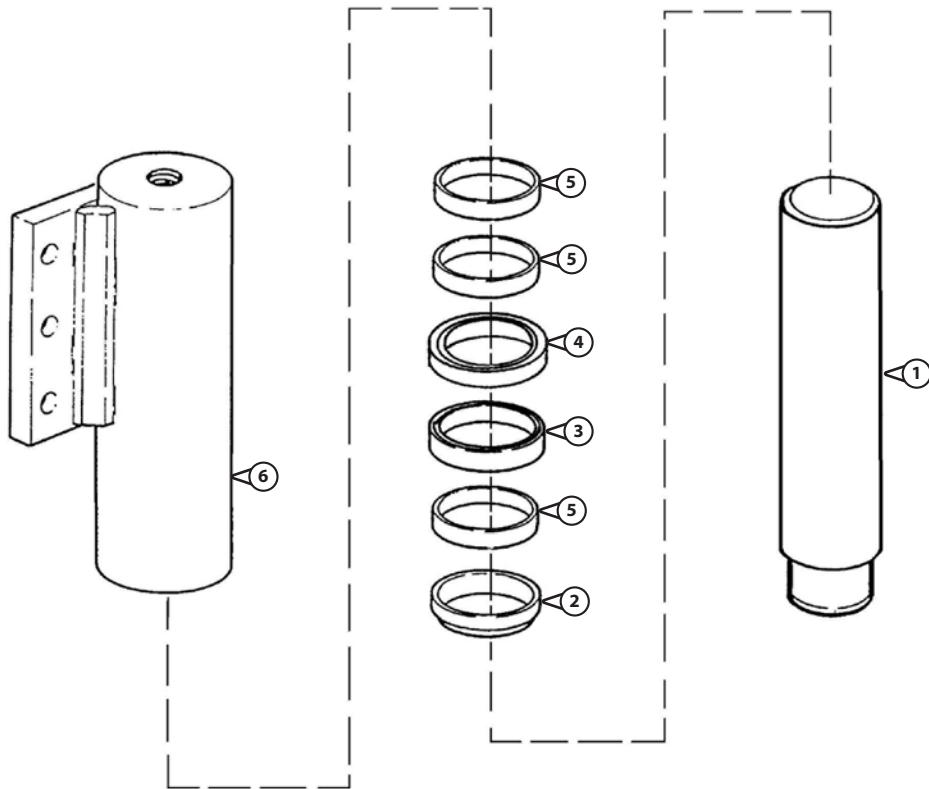
CHECK

Use a comparator (1,  70 - 14) to check the linearity of the rod along its entire length.


Check to make sure the rod is not cracked, corroded or scratched.


REAR AXLE BLOCKING CYLINER

70 - 535



DISASSEMBLY

Remove the rod (1,  70 - 27) from the cylinder jacket.

Remove the gasket (2,  70 - 27), the anti-extrusion rings (3,4,  70 - 27) and the guide rings (5,  70 - 27) of the cylinder (6,  70 - 27).

Change the gaskets and components, if necessary.

REASSEMBLY



Operation reverse to that for disassembly.

Note: Smear hydraulic fluid on the gaskets.

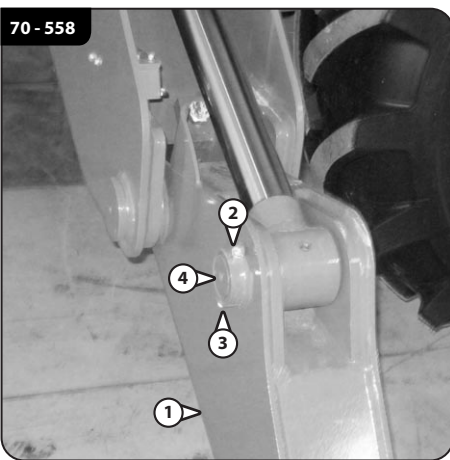
70.4.4 REMOVING THE STABILIZERS ASCENT AND DESCENT CYLINDERS







To remove the inclination cylinder, dismantle the mudguard to avoid accidental breakage.

Slacken the screws (1, ) 70 - 49) and remove the mud guard (2, ) 70 - 49).

Using the controls in the cab, bring the stabilizer leg close to the ground.



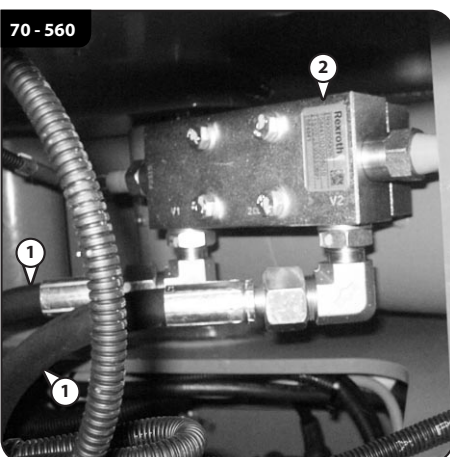
Hook up the stabilizer arm on the foot side (1, ) 70 - 50) to an overhead crane or an elevator.



Slacken the stop screw (1, ) 70 - 50) the nut (3, ) 70 - 50) and remove the pin (4, ) 70 - 50).



Rest the foot end of the stabilizers arm on the ground.

Retract the stabilizer rod completely using the controls in the cab.

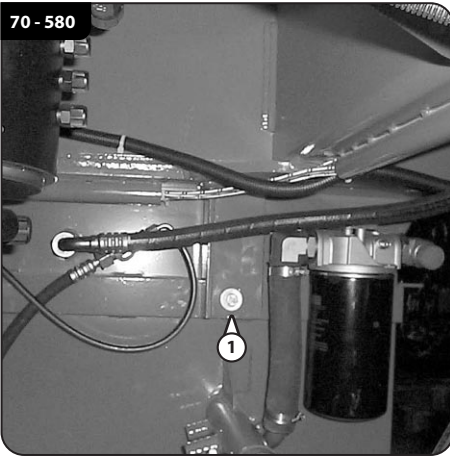



Disconnect the hydraulic pipes (1, ) 70 - 52) on the stabilizers inclination cylinder valve (2, ) 70 - 52).

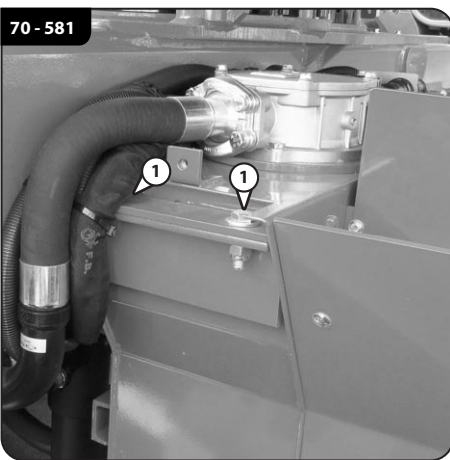
Close the orifices using the caps meant for the purpose to prevent dirt from entering inside.



70.5.1 REFITTING THE TANK

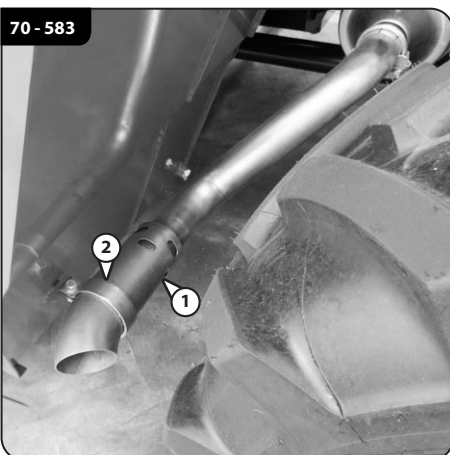
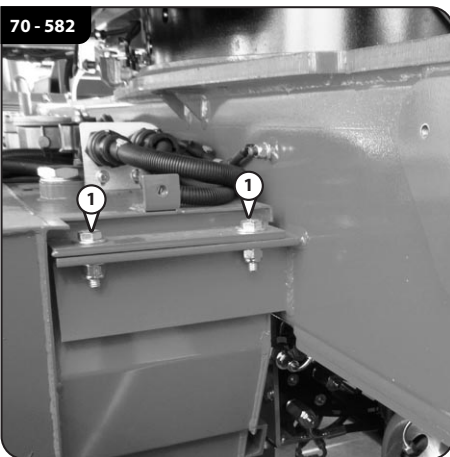
REFITTING THE HYDRAULIC FLUID AND FUEL TANK





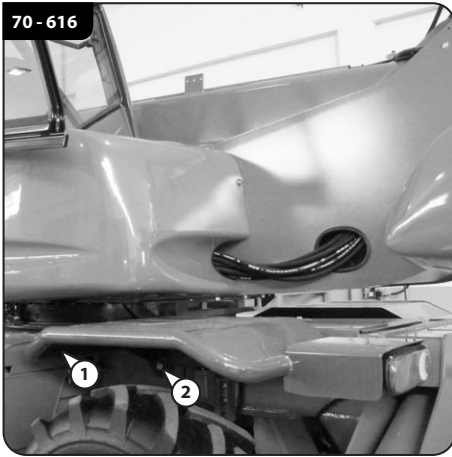
Position the tank on the chassis.
Tighten the screw (1,  70 - 72) on the inner side of the tank connected to the chassis.





Fit the screws on the front (1,  70 - 73) and rear (1,  70 - 74) of the tank.



Fix the silencer (1,  70 - 75) on the tank, securing it by means of the clamp (2,  70 - 75).



Refit the mudguard (1,  70 - 108) removed earlier by means of the screws (2,  70 - 108).

CLICK HERE TO **DOWNLOAD** THE COMPLETE MANUAL

- Thank you very much for reading the preview of the manual.
- You can download the complete manual from: www.heydownloads.com by clicking the link below



- Please note: If there is no response to CLICKING the link, please download this PDF first and then click on it.

CLICK HERE TO **DOWNLOAD** THE COMPLETE MANUAL

80.1 ELECTRICAL FEATURES AND SPECIFICATIONS

80.1.1 SOFTWARE

SOFTWARE VERSION

The software version installed on the vehicle's MC2M board is seen on the display in the cab when the panel is switched on.



MNT_XXX_YYY

80

The first 7 alphanumeric characters (MNT_XXX) displayed identify the machine type, while the remaining 4 identify the number of the software version.

Further details regarding the software versions installed on the electronic control devices of the vehicle are available in the advanced diagnostics pages that can be accessed by means of the F key.

To display these, press F5 on the display and then press F10.

MOVEMENTS ALLOWED FROM THE CAB WITH ROLLOVER PROTECTION EXCLUSION KEY ACTIVATED					
	BOOM WITHIN H=3m	BOOM WITHIN H=3m	BOOM BEYOND H=3m	BOOM BEYOND H=3m	NOTES
	BOOM RETRACTED	BOOM EXTENDED	BOOM RETRACTED	BOOM EXTENDED	
STABILIZERS RAISED	√				
STABILIZERS LOWERED	√	√			
TURRET ROTATION	√	√			
SLEWING UPWARDS	√	√			
SLEWING DOWNWARDS	√	√			
BOOM ASCENT	√ (only up to H=3m)	√ (only up to H=3m)			
BOOM DESCENT	√	√	√	√	
BOOM RETRACTION	√	√			
BOOM EXTENSION					
OPTION 1	√	√			
OPTION 2	√	√			

NOTE: The data given in the afore-mentioned Tables are applicable for all positions of the turret.

MACHINE ON TYRES WITH FIXED/ORH PLATFORM

MOVEMENTS ALLOWED FROM THE CAB					
	BOOM WITHIN H=3m	BOOM WITHIN H=3m	BOOM BEYOND H=3m	BOOM BEYOND H=3m	NOTES
	BOOM RETRACTED	BOOM EXTENDED	BOOM RETRACTED	BOOM EXTENDED	
STABILIZERS RAISED	√				
STABILIZERS LOWERED	√	√			
TURRET ROTATION	√	√			
SLEWING UPWARDS	√	√			
SLEWING DOWNWARDS	√	√			
BOOM ASCENT	√ (only up to H=3m)	√ (only up to H=3m)			
BOOM DESCENT	√	√	√	√	
BOOM RETRACTION	√	√			
BOOM EXTENSION					
OPTION 1	√	√			
OPTION 2	√	√			

VEHICLE ON STABILIZERS WITH RADIO CONTROL IN TILTING CONDITION

MOVEMENTS ALLOWED FROM THE CAB					
	BOOM WITHIN H=3m	BOOM WITHIN H=3m	BOOM BEYOND H=3m	BOOM BEYOND H=3m	NOTES
	BOOM RETRACTED	BOOM EXTENDED	BOOM RETRACTED	BOOM EXTENDED	
STABILIZERS RAISED	√				
STABILIZERS LOWERED	√	√	√		
TURRET ROTATION	√	√	√		The turret can be brought to the central position only if 1 of the 2 proximity switches +/-5° is reading.
SLEWING UPWARDS					
SLEWING DOWNWARDS					
BOOM ASCENT					
BOOM DESCENT					
BOOM RETRACTION					
BOOM EXTENSION					
OPTION 1					
OPTION 2					

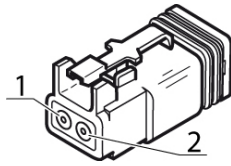


MOVEMENTS ALLOWED FROM THE CAB WITH PLATFORM EXCLUSION KEY ACTIVATED					
	BOOM WITHIN H=3m	BOOM WITHIN H=3m	BOOM BEYOND H=3m	BOOM BEYOND H=3m	NOTES
	BOOM RETRACTED	BOOM EXTENDED	BOOM RETRACTED	BOOM EXTENDED	
STABILIZERS RAISED	√				
STABILIZERS LOWERED	√	√			
TURRET ROTATION	√	√	√	√	The turret can be brought to the central position only if 1 of the 2 proximity switches +/-5° is reading.
SLEWING UPWARDS					
SLEWING DOWNWARDS	√	√	√	√	
BOOM ASCENT					
BOOM DESCENT					
BOOM RETRACTION	√	√	√	√	
BOOM EXTENSION					
OPTION 1	√	√	√	√	
OPTION 2					







R12	363
R13	364
R14	364
R15	365
R16	365
R35	423
R74	424
R75	424
R76	424
R77	424
R78	425
R79	425
R80	425
R81	426
R82	426
R83	426
RS232	393
S1	472
S2	472
S3	472
S4	473
S5	473
S6	473
S8	349
S11	348
S12	348
S13	348
S14	348
S16	348
S17	348
S18	348
S19	348
S21	444
S22	444
S23	356
S23A	356
S24	356
S25	356
S26	356
S26A	356
S30	349
S31	349
S100	348
STR2	393

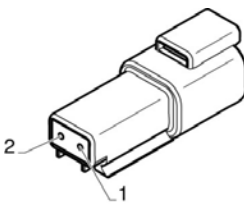
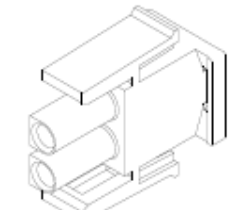
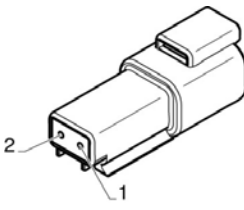
STR3	394
T1	349
TLM	394
TV	426
VIEW	394
X1	369
X1	426
X1	447
X1	462
X2	356
X2	429
X2	446
X2	462
X3	351
X3	357
X3	358
X4	358
X4	359
X4	370
X4	371
X5	352
X5	372
X7	436
X9	460
X9	465
X10	454
X11	444
X11	455
X11	463
X11	468
X11A	464
X11A	467
X12	428
X12	444
X13	445
X14	401
X14	445
X14	456
X15	445
X15	457
X16	350
X16	428
X16	429
X16	445

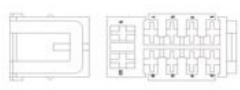
X16	462
X17	445
X18	445
X20	395
X20	396
X20	430
X21	397
X21	430
X21	431
X21	432
X22	433
X22	458
X23	434
X23	459
X24	350
X26	357
X28	351
X29	357
X30	358
X31	358
X32	358
X32	435
X33	358
X33	435
X34	446
X37	435
X38	398
X39	398
X40	435
X42	436
X46	460
X47	464
X51	401
X51	474
X53	402
X53	474
X55	398
X70	398
X71	353
X75	402
X76	402
X86	465
X88	437
X90	465

X101	426
X103	427
X105	463
X105	463
X105	466
X106	466
X107	427
X107	466
X108	466
X109	466
X500	353
X503	436
X504	436
XA	467
XA	469
XA/C	438
XA/C	439
XAS	398
XB	468
XB	469
XBI	372
XBS	398
XCD	399
XD+	373
XD1	446
XDK	439
XMS	402
XPA	439
XRA	461
XRB	461
XRC	461
XRD	373
XRS	373
XS1	439
XS2	440
XSC	353
XSP	402
XSR	402
XVR	399

Ref.	Pin	Wire colour	Section	Destination	Pin	Image			
X500	1	White*		MC2M-2	23				
				X16	26				
				X71	3				
	2	Brown*		MC2M-2	25				
				X16	25				
				X71	4				
X71	1	Orange		PSC	7				
				X3	23				
				XSC	1				
	2	Black		GND					
				3	White*			MC2M-2	23
								X16	26
	X500	1							
	4	Brown*		MC2M-2	25				
				X16	25				
X500				2					
XSC	1	Orange	1,5	PSC	7				
				X3	23				
				X71	1				
	2	Black		GND					
	4	Light blue-Yellow		X5	1				
	8	Black-Blue		X3	29				
	9	Red-Blue		X3	27				
	10	White-Yellow	1,5	X3	25				
	11	Grey-Purple	1,5	X3	28				
	12	Yellow-Purple	1,5	X3	26				
	13	Purple-Blue		PSC	1				
	14	Purple-Black		PSC	2				
	15	Purple-Red		PSC	3				
	16	Purple-Green		PSC	4				
	17	Purple-White		PSC	5				
	18	Light blue-Red		X16	10				
	19	Green-Brown		X16	16				
	20	Green-Yellow		X16	20				
	21	Grey		MC2M-3	L15				
	22	Green		MC2M-3	L20				
	23	Blue		MC2M-3	L26				
	24	Purple		MC2M-3	L29				
	25	Pink		MC2M-3	L5				
	26	Yellow #1		MC2M-3	R36				
	27	Pink-Blue #1		MC2M-2	10				
	28	Pink-Black		MC2M-2	6				
	29	Green-Grey		X16	7				
	30	Light blue-Grey #1		X16	11				
	31	Brown #1		MC2M-3	R37				

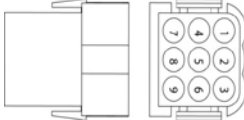
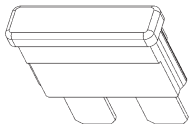
Ref.	Pin	Wire colour	Section	Destination	Pin	Image
R11	30	Purple	1,5	F14	OUT	  
				R13	30	
	85	Black		R1	85	
				R3	85	
				R4	85	
				R6	85	
				R9	85	
				R10	85	
				R12	85	
				R13	85	
				R14	30	
				R14	85	
				R16	85	
86	Blue-Black			X1	T	
				X1	U	
87	Green	1,5		X5	12	
R12	30	Orange	1,5	F13	OUT	  
				R10	30	
	85	Black		R1	85	
				R3	85	
				R4	85	
				R6	85	
				R9	85	
				R10	85	
				R11	85	
				R13	85	
				R14	30	
				R14	85	
				R16	85	
86	White-Pink			X1	T	
				X1	U	
87	Grey-Black	1,5		X5	11	
				X5	22	

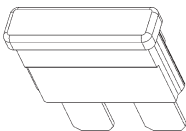
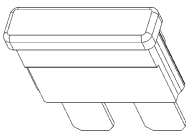
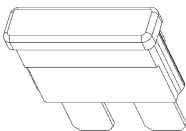
<i>Ref.</i>	<i>Pin</i>	<i>Wire colour</i>	<i>Section</i>	<i>Destination</i>	<i>Pin</i>	<i>Image</i>
XD+	1	Grey-Blue	1,5	X1	N	
				X4	13	
				XRD	1	
	2	Grey-Purple	1,5	X5	14	
XRD	1	Grey-Blue		X1	N	
				X4	13	
				XD+	1	
	2	Grey-Red		F7	OUT	
				X5	25	
				XRS	1	
XRS	1	Grey-Red		F7	OUT	
				X5	25	
				XRD	2	
	2	Brown-Red		X5	24	

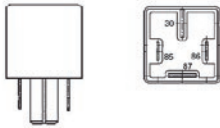
Ref.	Pin	Wire colour	Section	Destination	Pin	Image	
14	1	Orange-Yellow		I26	3		
				I26	4		
				I1	5		
				I27	1		
				I70	5		
				I77	3		
				I35	3		
				I69	1		
				I24	3		
				I24	4		
				I24	6		
				I9	5		
				I51	1		
				I10	1		
				I73	1		
				X20	E		
				I76	1		
				I78	1		
				I79	1		
	5	Yellow-Green		STR2	5		
	9	Black		GND			
	10	Red-Green #13			I1		10
					I70		10
					I77		10
					I35		10
					I27		6
					I31		10
					I30		10
					I29		10
					I28		10
					I9		10
					I2		10
					I54		10
I24					10		
I76					10		
X20	G						
I78	10						
I79	10						
XAS	1						



Ref.	Pin	Wire colour	Section	Destination	Pin	Image	
L30	1	Brown-Red		I26	8		
				X55	1		
				X21	2		
	2	Black		GND			
L31	1	Brown-Yellow		I26	2		
				XBS	1		
				GND			
	2	Black		GND			
RS232	1	Blue*		X20	J		
	2	Brown*		X20	K		
STR2	1	Green-White		I24	2		
	2	Green-Grey		I24	8		
	3	Brown-White		I69	2		
	4	Brown-Grey		I69	3		
	5	Yellow-Green		I4	5		
	6	White*			VIEW		6
					X21		34
	8	Red-Black		1,5	X21		14
	9	Light blue-White			I2		1
	10	Light blue			I2		7
	11	Pink-Green			X21		20
	12	Pink-Red			X21		21
	13	Light blue-Yellow			TLM		4
	14	Brown*			VIEW		5
					X21		33
	15	Grey-Yellow			X21		15
	16	Grey-Pink			X21		16
	17	Pink-Brown			X21		23
	18	Pink-Blue			X21		24
	19	Pink			I35		1
	20	Orange			I35		7
	21	Purple-Yellow			X20		T
					I70		1
22	Purple			X21	8		
23	Black			GND			

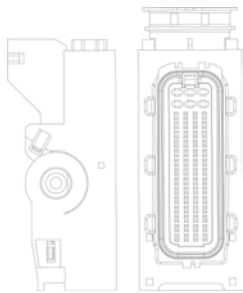
DASHBOARD WIRING

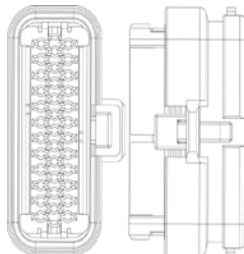
Ref.	Pin	Wire colour	Section	Destination	Pin	Image	
DL	1	Yellow-Red	1,5	X16	4		
	2	Blue	1,5	X16 X21	9 28		
	3	Blue-Black	1,5	X16 X21	8 27		
	4	Pink-Red		X21	21		
	5	Pink-Black		DL F44	9 OUT		
	6	Pink-Yellow		X20 R79	L C		
	7	Pink-Green		X21	20		
	8	Purple		X21	8		
	9	Pink-Black		DL F44	5 OUT		
	DM	1	White-Orange		X21		1
5		Light blue		X37	4		
7		Pink		F34	OUT		
8		Pink-Brown		X21	23		
9		Pink-Blue		X21	24		
F33	IN			R78	87		
				F71	IN		
				F52	IN		
				F55	IN		
				F57	IN		
				F41	IN		
	OUT	Red-Green #13			X20		G
					I66		10
					I7		10
					I59		10
					I57		10
					I56		10
					I68		10
					I58		10
I67	10						
X20	G						

Ref.	Pin	Wire colour	Section	Destination	Pin	Image
F64	IN			R35	87	
				F54	IN	
				F35	IN	
				F59	IN	
				F69	IN	
				F48	IN	
				F72	IN	
				F34	IN	
				F67	IN	
				F66	IN	
				F51	IN	
				F43	IN	
				F44	IN	
	F46	IN				
	OUT	Pink	1,5	R77	87	
F65	IN			R74	87	
				F37	IN	
				F42	IN	
				F68	IN	
				F45	IN	
	F62	IN				
	OUT	Red-Brown	1,5	X22	23	
F66	IN			R35	87	
				F54	IN	
				F35	IN	
				F64	IN	
				F69	IN	
				F48	IN	
				F72	IN	
				F34	IN	
				F67	IN	
				F59	IN	
				F51	IN	
				F43	IN	
				F44	IN	
	F46	IN				
	OUT	Blue	2,5	I67	1	

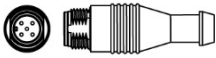

Ref.	Pin	Wire colour	Section	Destination	Pin	Image	
R35	30	Red	10	F60	IN		
				KEY	1		
				F36	IN		
				F61	IN		
				R78	30		
				X1	1		
				F74	IN		
				XA/C	1		
				XA/C	2		
				XA/C	A		
				XA/C	B		
				F70	IN		
				F40	IN		
				F49	IN		
	R74	30					
	85	Black		GND			
	86	Purple-Red			R81		30
					R74		86
	87	Brown	10	10	F59		IN
					F35		IN
					F64		IN
					F69		IN
					F51		IN
					F72		IN
					F43		IN
					F67		IN
					F66		IN
					F54		IN
					F44		IN
					F34		IN
F46	IN						
F48	IN						

Ref.	Pin	Wire colour	Section	Destination	Pin	Image
X22	1	Yellow-Red	1,5	F55	OUT	 
	2	Grey-Red		X51	5	
	3	Blue-Pink	1,5	X22 R82	4 87	
	4	Blue-Pink		X22 R82	3 87	
	5	Blue-Green	1,5	X22	6	
	6			R75	87	
	7			X22	5	
	8			R75	87	
	9	Yellow-Grey		X7	P	
	10	Pink-Red		F50	OUT	
	11	Brown-Pink		X21	5	
	12	Orange-Blue		F56	OUT	
	13	Grey	1,5	I7	5	
	14	Green-Grey		X21	19	
	15	Green-Brown		X21	18	
	16	Green-Red		X21	17	
	17	Light blue-Yellow		R76	86	
	18	Light blue-Green		I22	11	
	19	Grey-Purple		XDK X16	2 3	
	20	Grey-Green		R77	86	
	21	Pink-Black	1,5	R77	30	
	22	Brown-Blue		X21	25	
	23			X37	6	
	24	Red-Green	1,5	F52	OUT	
	25	Yellow-Black #1	1,5	F53	OUT	
	26	Red-Brown	1,5	F65	OUT	
	27	Green	1,5	X12	5	
	28	White-Red		MA	2	
	29			F39	OUT	
	30	Brown-Red		X21	2	
	31	Brown-Green		X21	3	
32	Pink-White		R75	86		
33	Pink-Yellow		R82	86		
34	Purple-White		X20	U		
35	Purple-Yellow		X20	T		

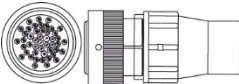
Ref.	Pin	Wire colour	Section	Destination	Pin	Image
EIC1	1	Brown*		ECM-A1	15	
	2	White*		ECM-A1	60	
	3	Blue-Pink		ECM-A1	6	
	4	Red-Blue		ECM-A1	14	
	5	White*		ECM-A1	26	
	6	Brown*		ECM-A1	41	
	7	Grey-White		ECM-A1	11	
	8	Black-Blue		ECM-A1	28	
	9	Brown*		ECM-A1	59	
	10	White*		ECM-A1	44	
	11	Shield	/	ECM-A1	58	
				EIC1	13	
				EIC1	24	
	12	Red-White		ECM-A1	13	
	13	Light blue-Black		ECM-A1	58	
				EIC1	11	
				EIC1	24	
	14	Light blue-Orange		ECM-A1	57	
	15	Yellow-Black		ECM-A1	23	
	16	Yellow-Blue		ECM-A1	38	
	17	Brown-White		ECM-A1	10	
	18	Brown-Green		ECM-A1	40	
	19	Brown-Black		ECM-A1	25	
	20	Light blue-Yellow		ECM-A1	55	
	21	Purple-White		ECM-A1	12	
	22	Purple-Black		ECM-A1	27	
	23	Purple-Green		ECM-A1	43	
	24	Light blue-Black		ECM-A1	58	
				EIC1	13	
				EIC1	11	
	25	Blue-Black		ECM-K1	81	
	26	Blue		ECM-K1	82	
	27	Brown*		ECM-A1	4	
	28	White*		X11	3	
				X1	P	
				XD1	A	
				X34	4	
	29	Brown*		ECM-A1	50	
	30	White*		ECM-A1	35	
	33	Pink-White		ECM-A1	9	
	34	Pink-Green		ECM-A1	39	
	35	Pink-Black		ECM-A1	24	
	37	Brown*		ECM-A1	49	
38	White*		ECM-A1	34		
41	Light blue-White		ECM-A1	8		
42	Light blue-Green		ECM-A1	53		
43	Light blue-Black		ECM-A1	37		

Ref.	Pin	Wire colour	Section	Destination	Pin	Image
MDCP	1	Blue*		Negative from battery		
	3	Red-Black	1,5	MC2M-1	1	
				MC2M-1	2	
				MC2M-1	3	
				X23	1	
	4	Light blue-Yellow		X22	15	
	13	Red-Black		MC2M-2	1	
				MDCP	16	
				X23	10	
	14	Red-Yellow #1		X9	M	
	16	Red-Black		MC2M-2	1	
				MDCP	13	
				X23	10	
	17	Brown*		MC2M-2	7	
				X23	13	
	18	White*		MC2M-2	26	
				X23	14	
	19	Brown*		MC2M-2	25	
				X9	P	
				X11	18	
				X14	U	
				X23	16	
				XRA	4	
	20	White*		MC2M-2	23	
				X9	Q	
				X11	20	
				X14	V	
				X23	17	
	XRA	5				
	24	Grey-Pink		X9	N	
	25	Grey-Yellow		X9	D	
	26	Grey-Blue		X9	E	
	27	Orange-Purple		X9	O	
28	Orange-Yellow		X9	G		
29	Brown-Blue		X9	H		
30	Brown-Grey		X9	J		
31	White-Grey		X9	K		
33	Grey-Black		X22	12		
			MC2M-3	L8		

BOOM WINDER CABLE

Ref.	Pin	Wire colour	Section	Destination	Pin	Image
X105	1	Green		X105	1	
	2	Yellow		X105	2	
	3	Brown*		X105	3	
	4	White*		X105	4	
X105	1	Green		X105	1	
	2	Yellow		X105	2	
	3	Brown*		X105	3	
	4	White*		X105	4	

PLATFORM INTERFACE WIRING

Ref.	Pin	Wire colour	Section	Destination	Pin	Image
X11	1	Grey-Black	2,5	X11A	1	
	2	Black	2,5	X11A	2	
	3	Orange-Black		X11A	3	
	4	Orange-Yellow		X11A	4	
	5	Green-Brown		X11A	5	
	6	Green-Grey		X11A	6	
	7	Green-Yellow		X11A	7	
	8	Green-White		X11A	8	
	9	Grey-Red		X11A	9	
	10	Grey-Black		X11A	10	
	11	Green		X11A	11	
	12	Blue		X11A	12	
	13	Brown-Black		X11A	13	
	14	Brown-Green		X11A	14	
	15	Black-Yellow		X11A	15	
	16	Black-White		X11A	16	
	17	Orange-Green		X11A	17	
	18	Brown*		X11A	18	
	19	Pink-Green		X11A	19	
	20	White*		X11A	20	
	21	Blue-White	1,5	X11A	21	
	22	Blue-Yellow	1,5	X11A	22	
	23	White-Red		X47	1	
	24	Brown-Purple		X47	2	
	25	Blue-Green	1,5	X11A	25	
	26	Blue-Black	1,5	X11A	26	
	27	Brown*		X11A	27	
	28	Orange-Yellow		X11A	28	
	29	White*		X11A	29	

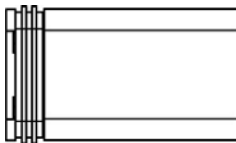
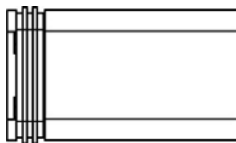

Ref.	Pin	Wire colour	Section	Destination	Pin	Image
S4	1	Orange	0,75	S1	1	
				S2	1	
				S3	1	
				S5	1	
				S6	1	
				C1	29	
	3	Black	0,75	S1	3	
				S2	3	
				S3	3	
				S5	3	
4	White	0,75	S6	3		
			C1	30		
C1	26					
1	1					
S5	1	Orange	0,75	S1	1	
				S2	1	
				S3	1	
				S4	1	
				S6	1	
				C1	29	
	3	Black	0,75	S1	3	
				S2	3	
				S3	3	
				S4	3	
4	White	0,75	S6	3		
			C1	30		
C1	27					
1	1					
S6	1	Orange	0,75	S1	1	
				S2	1	
				S3	1	
				S4	1	
				S5	1	
				C1	29	
	3	Black	0,75	S1	3	
				S2	3	
				S3	3	
				S4	3	
4	White	0,75	S5	3		
			C1	30		
C1	28					
1	1					

DIAGRAM 2

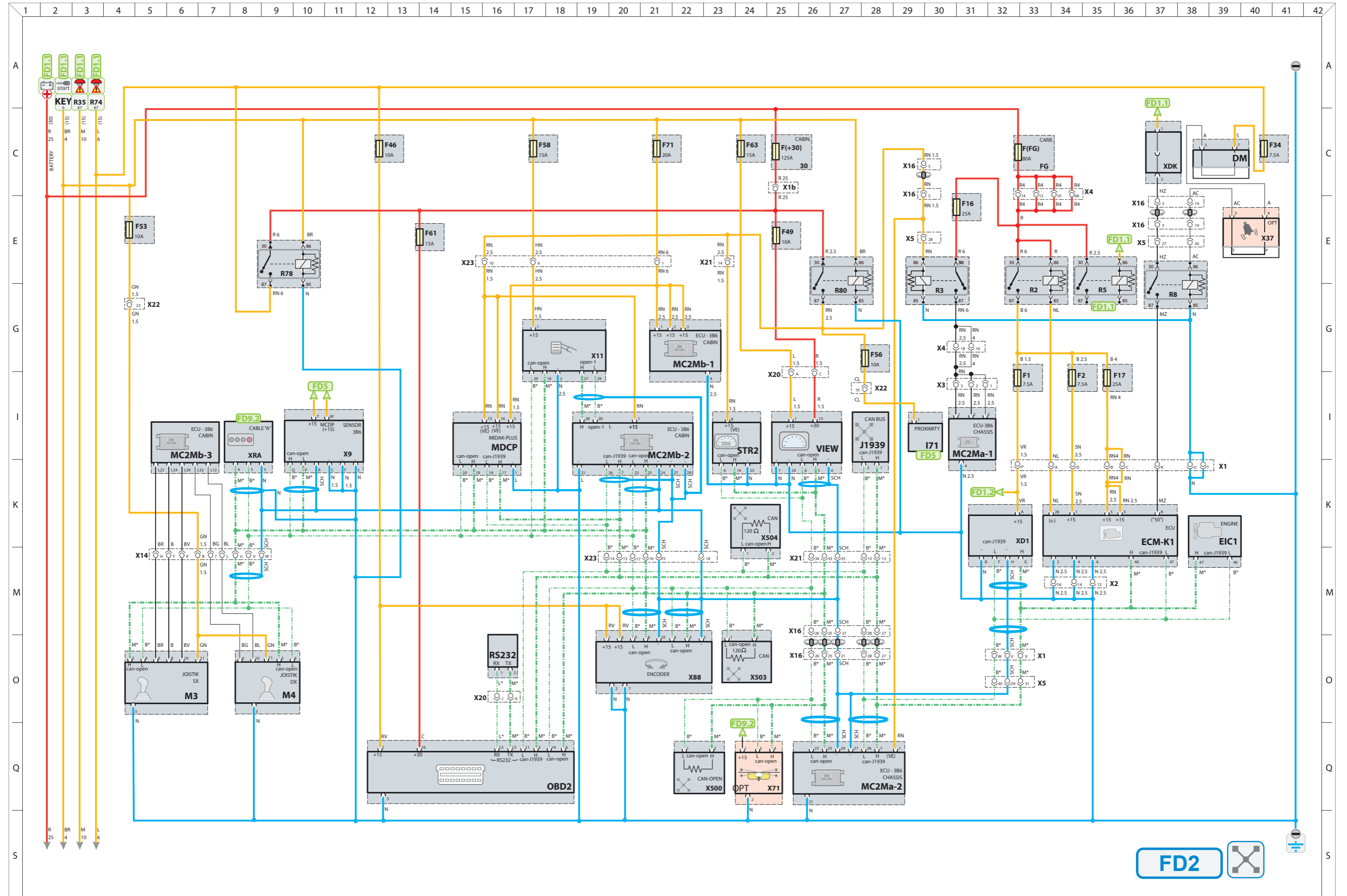


DIAGRAM 6

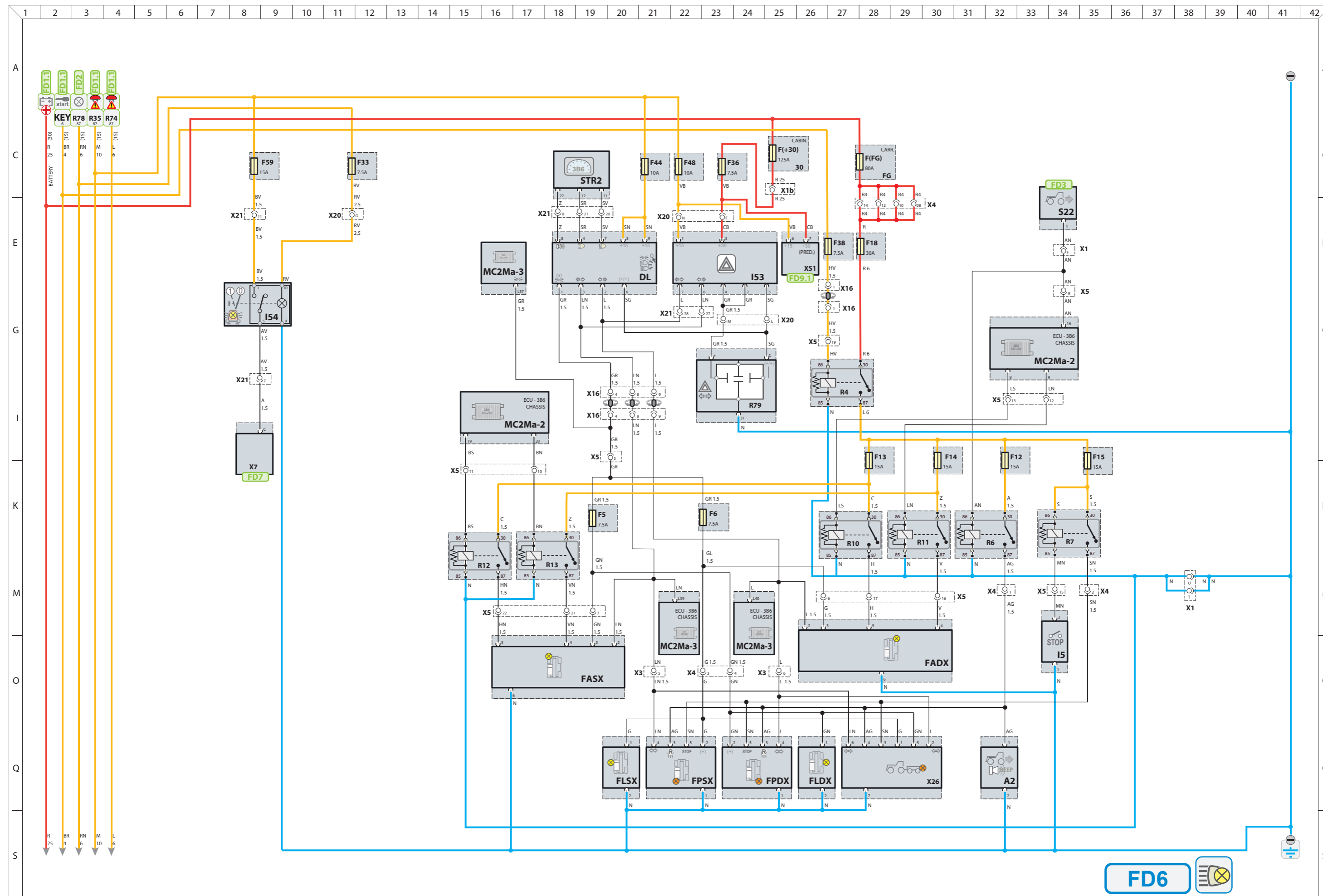


DIAGRAM 10

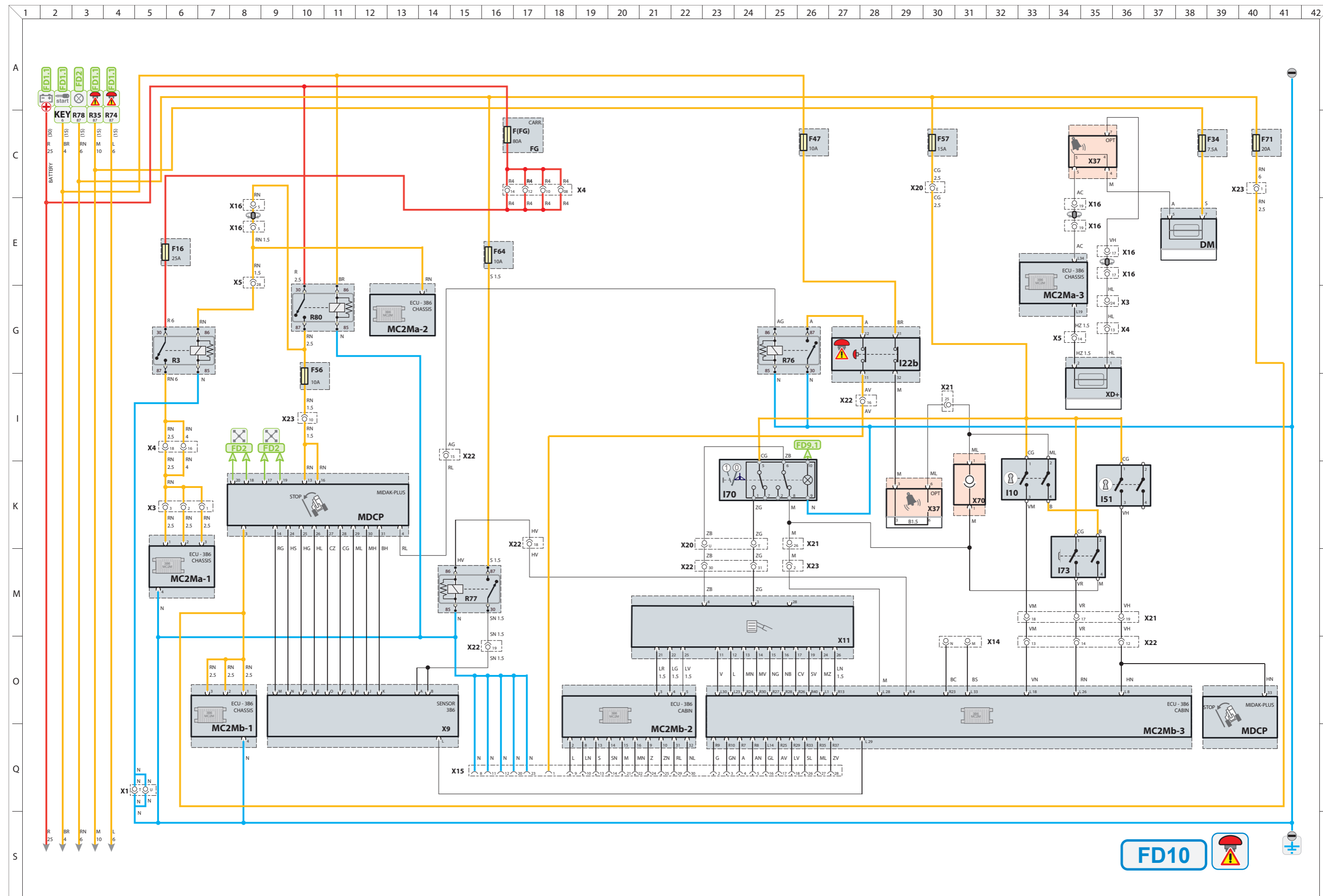


DIAGRAM 3

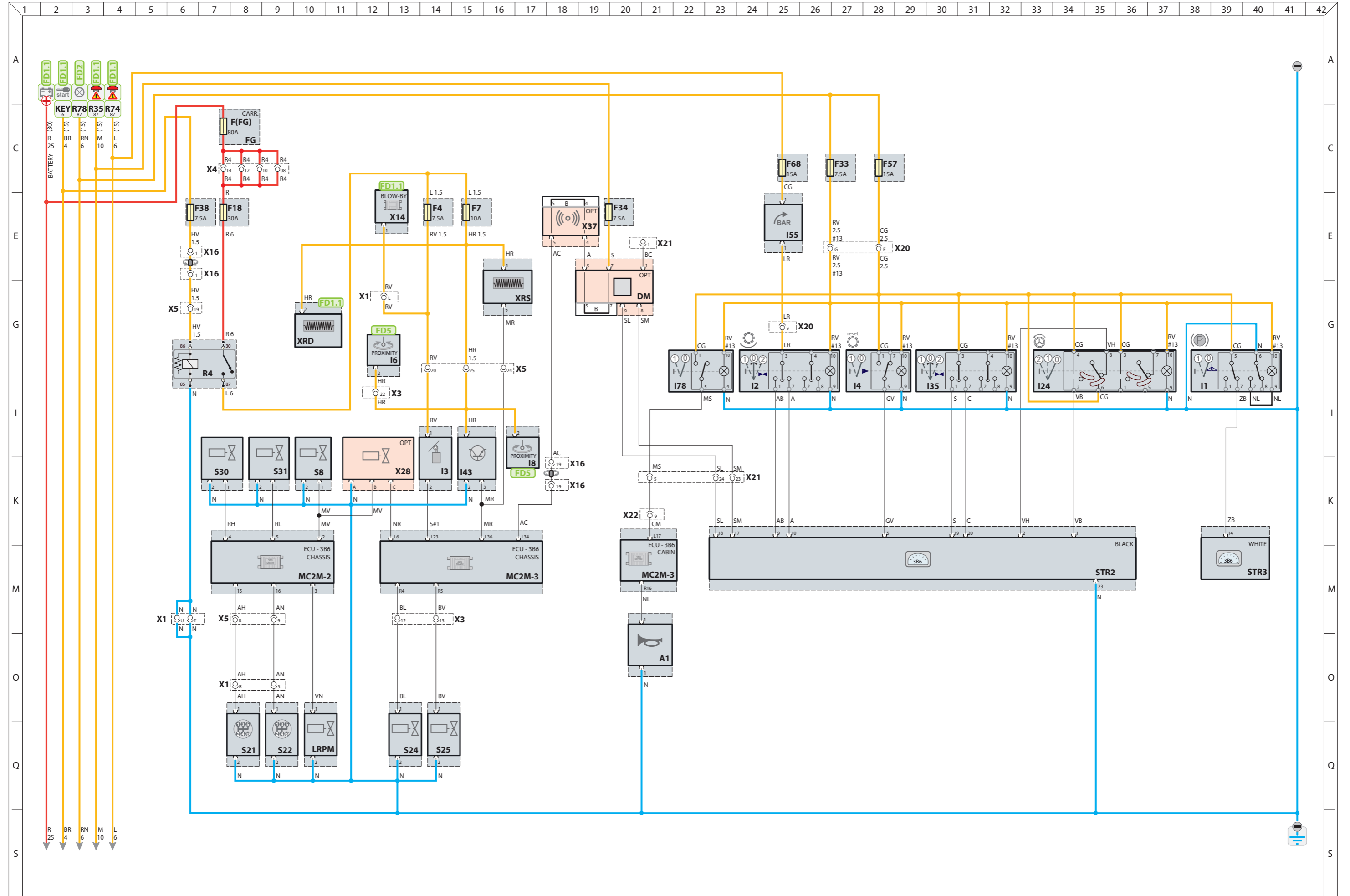
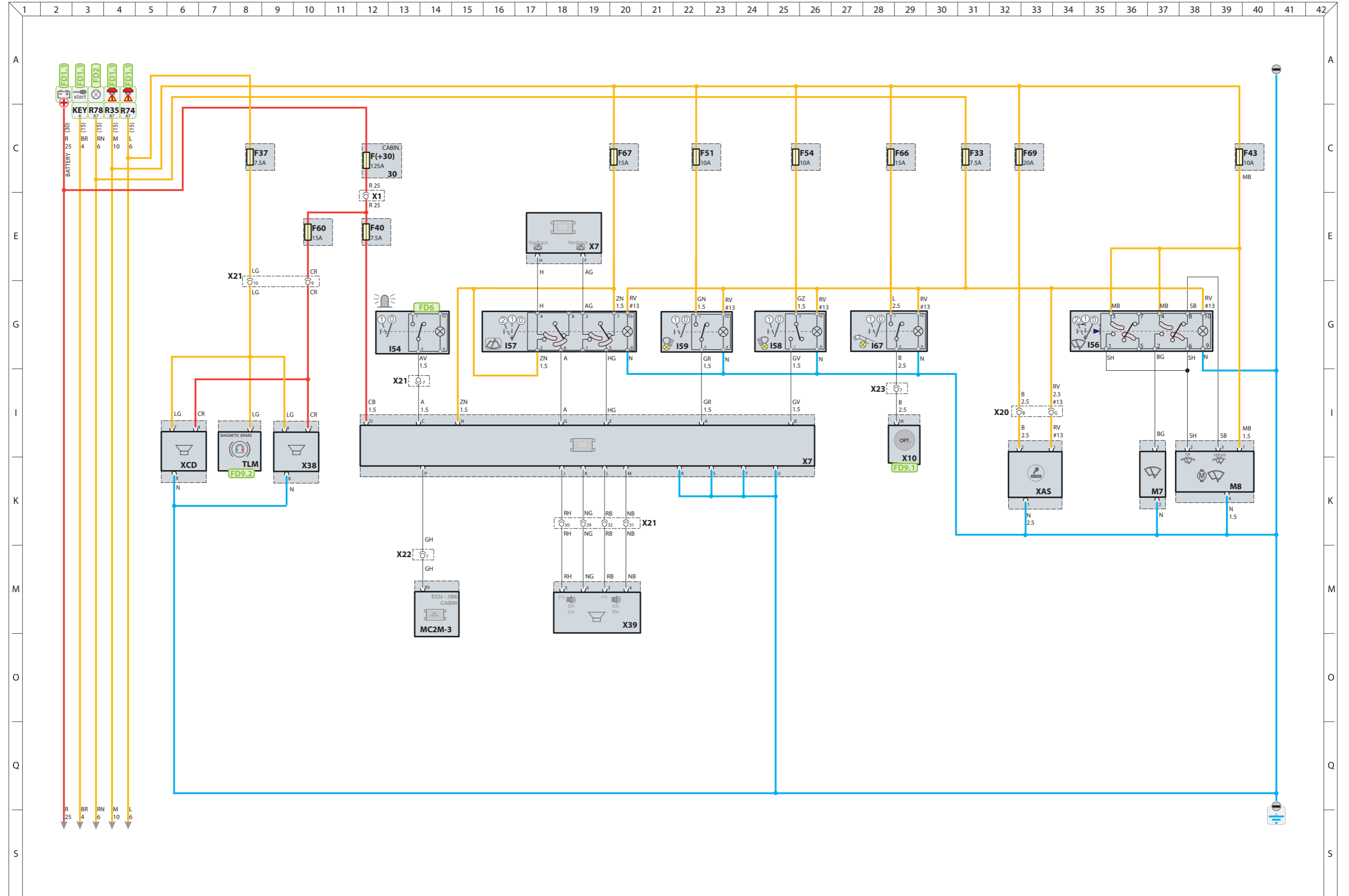


DIAGRAM 7



Ref.	Description	Position on wiring diagram						Observations
		Assembly 1	Assembly 2	Chassis	Turret	Cab	Engine	
M7	Windscreen wiper pump connector		Q23			M23		
M8	Front windscreen wiper motor connector		Q33			I26		
M10	Heating 1°/2° speed fan connector		Q31			I31		
M11	Heater pump	E13			M36			FOR MRT 360° ONLY
M12	Pneumatic seat	G18/G19				M11		
MA	Winch micro switch set-up connector		Q32			I31		
MC2M-1	3B6 control unit - chassis part	E21		K27/K28				
MC2M-2	3B6 control unit - chassis part	E22		K27/K28				
MC2M-3	3B6 control unit - chassis part	E23/E24		K27/K28				
MC2M-1	3B6 control unit - cab part	G14			Q33/Q34			
MC2M-2	3B6 control unit - cab part	G14			Q34/Q35			
MC2M-3	3B6 control unit - cab part	G14			O34/O35			
MDCP	Midak-plus connector (Roll-over protection)	G14			O35			
OBD2	Diagnostics connector		O31			I26		
R35	Turret line functions "15" positives activation remote control switch MRT EASY EN13849		Q32			K27		
RS232	XRS232 connector		C31			I33		
S8	Parking brake solenoid valve	I27		M17				
S11	RH front beam solenoid valve	K24		K17				
S12	LH front beam solenoid valve	K25		K18				
S13	LH rear beam solenoid valve	K25		K18				
S14	RH rear beam solenoid valve	K26		K18				
S16	RH front stabilizer solenoid valve	K24		I14				
S17	LH front stabilizer solenoid valve	K25		I14				
S18	LH rear stabilizer solenoid valve	K25		I13				
S19	RH rear stabilizer solenoid valve	K26		I13				
S21	Forward movement solenoid valve	M22				K18		
S22	Reversing solenoid valve	M22				K20		
S23	RH-axle-block solenoid valve	M10/M11		C25				
S23A	RH-axle-block-micro switch	M11		C24				
S24	Crab steering solenoid valve	K15		E24				
S25	Concentric steering solenoid valve	K15		E24				
S26	LH-axle-block solenoid valve	I10/I11		G34				
S26A	LH-axle-block-micro switch	I11		G33				
S30	Low speed solenoid valve	I26		K18				
S31	High speed solenoid valve	I26		K18				
S100	Fans diverter solenoid valve	K27		M12				valid up to machine S/N 765922
STR2	3B6 primary instrument inputs/outputs		E33			I33/I34		
STR3	3B6 primary instrument inputs/outputs		E34			I33/I34		
T1	Fuel level sensor	G16		I28				
TLM	Telma magnetic braking set-up connector		E31			K34		
TV	TV cameras video set-up connector		O32			I30		
VIEW	3B6 main instrument power supply		C32			I33		
X1	Direct positive from battery for powering turret	E23				G32		
X1b	Direct positive from battery for powering turret		M21			S27		
X2	Engine line-rear chassis line interface connector	K23		I15		I27		
X3	Front chassis line-rear chassis line interface connector	K23		I18				
X4	Rear chassis line connector	E22		M26				

Ref.	Description	Position on wiring diagram						Observations
		Assembly 1	Assembly 2	Chassis	Turret	Cab	Engine	
X5	Front chassis line connector	E22		M27				
X7	Cab system interface connector		O21			Q31		
X9	3B6 sensors connection connector	I12			M30			
X10	Optional connector	I12			M33			
X11	Boom/platform functions interface connector	G12			M30			
X11b	Water in fuel sensor	O22					M18	
X12	Heater unit connector		Q33			G26		
X12b	Intercooler-fan	O23					K18	
X13	Spark plugs	O23					O17	
X14	Cab system - driver's seat interface connector	G16			Q30	O14		
X14b	Blow-by-heater	M17					I13	
X15	Walvoil connector (boom/cab movements)	G12			M33			
X15b	Alternator-d+	M17					K13	
X16	Connector to rotary manifold	G17	O21	I26		Q31		
X16b	Ignition-50°	M17					K15	
X17	Air-filter-switch	M16					I13	
X18	Air-temperature	M16					G14	
X20	Cab system interface connector		Q32			G31		
X21	Cab system interface connector		Q32			G31		
X22	Cab-turret line interface connector	G16	O21		Q31	Q24		
X23	Cab-turret line interface connector	G16	O21		Q31	S24		
X26	Trailer connector	K7		C35				
X28	Hydraulic braking solenoid valve connector	G24		I19				OPTIONAL
X30	Positive from battery	M7		C37				
X31	DPF pressure sensor (exhaust gas pressure)	K16		E27				
X32	Inlet doc sensor (exhaust gas temperature)	K16		E27				
X32b	Thermostat connector		C19			E22		
X33	Inlet DPF sensor (inlet air temperature)	K16		E27				
X33b	Display ambient thermostat connector		C19			E22		
X34	Probe-lambda connector	M17					I16/I17	
X37	Anti-theft device connector		O31			G22		
X38	Standard vehicle radio power supply connector		I35			K41		
X39	Loudspeakers vehicle radio connector		I36			K41		
X40	Big mixer bucket connector		Q31			I26		
X42	Heater thermostat diagnostics connector		Q31			K26		
X46	Set-up connector	I8			K36			OPTIONAL
X47	Micro chain	I30/I33/I34			A17/A18			FOR MRT 1840 ONLY
X51	Platform inclination switch	G18				M5		
X53	Optional exclusion switch	E19				O9		
X55	Folding stabilizers configuration		O32			E26		
X70	Radio control switch by-pass		E31			K34		
X71	Levelling sensor	G23		K19				OPTIONAL
X75	Seat inclination/micro switch	G19				M11		
X76	Pneumatic seat set-up connector	G19				M12		
X86	Boom suspension	I7			K36			OPTIONAL
X88	Rotary manifold encoder connector		O21			S26		
X90	Optionals power supply set-up connector	K4			G36			OPTIONAL
X101	Heater signal connector		C19			E22		
X103	Heating fan switch set-up connector		C18			G22		
X105	3B6 cable reel connector	K5			G36			

80.11.2 FUNCTIONS

MC2M T (turret)

It is the master unit which controls the vehicle movement.

The main functions are:

Read the input power and check the output:

- Detect and control the signals from the other units of the vehicle;
- Check the joysticks and control movements;
- Measure the engine data from the can bus;
- Interface with the transmission;
- Interface with the directional control valve;
- Interface with the accessories identification;
- Interface with the TERA7 display.

MC2M C (chassis)

It is a slave unit for reading and activating the output.

The main functions are:

- Read the input power and check the output;
- Communicate with the other units of the vehicle;
- Interface with the TERA7 display.

IO-CORE (TERA 7)

It is a slave unit for reading and activating the output.

The main functions are:

- Read the input power and check the output;
- Communicate with the other units of the vehicle;
- Interface with the TERA7 display.

MIDAC PLUS (LMI)

It is a slave unit for reading and activating the output.

The main functions are:

- Read the input power and check the output;
- Detect and control the signals from the other units of the vehicle;
- Interface with the TERA7 display.
- Interface with the directional control valve;
- LMI Function
-

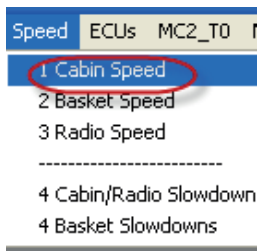
SPEED CONTROL FROM CAB

The speed of each movement can be adjusted within 0-100%.
If the value is 100% it means maximum control at the valve. Lower values reduce the speed proportionally.

Note: The speed value is proportional to the reel travel and not to the speed of the boom controlled, because this depends on the sections, the load and the available capacity of the pump.

To adjust the speed from the cab, the parameters in the Table below must be modified.
To calibrate the speed, just set the required value.
The column on the RH shows examples of values recorded on a prototype.

Movement	Associated parameter	Default value
Boom up	P100	
Boom down	P101	
Rotate to the RH	P102	
Rotate to the LH	P103	
Forks up	P104	
Forks down	P105	
NA	P106	
NA	P107	
Telescopic boom out	P108	
Telescopic boom in	P109	
Accessory 1	P110	
Accessory 2	P111	
Winch up	P112	
Winch down	P113	

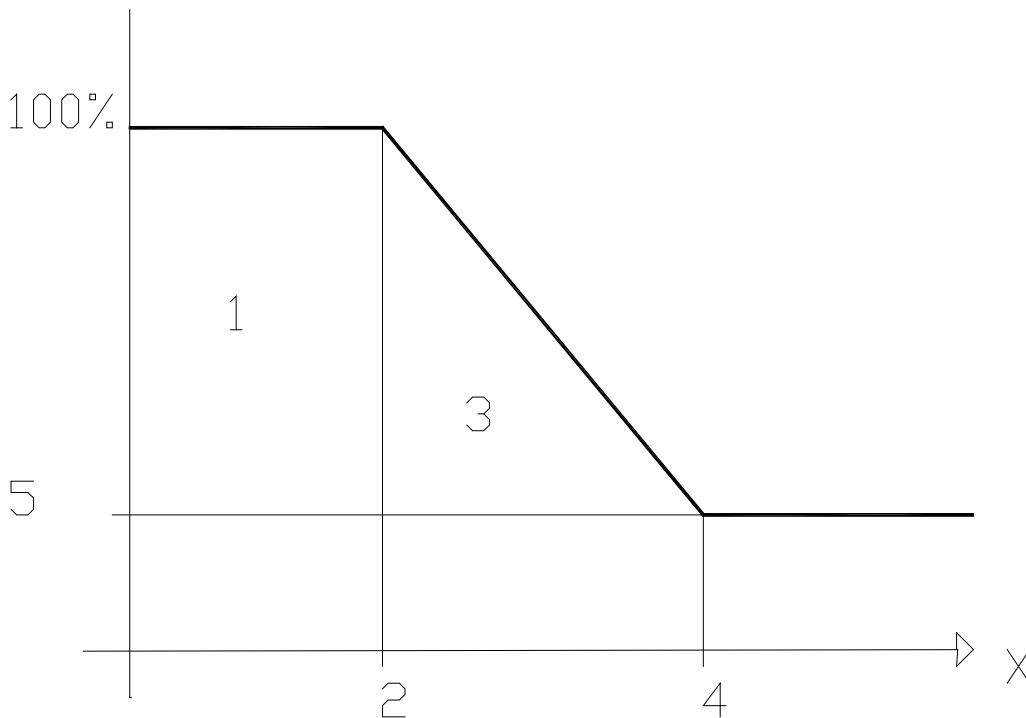


ID	Npar	T1	Value	Um	Range	Cabin Speed Regulations
0	P100		100	%	40 - 100	Boom Lift
1	P101		100	%	40 - 100	Boom Down
2	P102		100	%	40 - 100	Rotation Cw
3	P103		100	%	40 - 100	Rotation Ccw
4	P104		100	%	40 - 100	Forks Up
5	P105		100	%	40 - 100	Forks Down
6	P108		100	%	40 - 100	Boom extend
7	P109		100	%	40 - 100	Boom retract
8	P110		100	%	40 - 100	Option Direction 1
9	P111		100	%	40 - 100	Option Direction 2
10	P112		100	%	40 - 100	Winch Up
11	P113		100	%	40 - 100	Winch Down
12						
13						
14						
15						
16						
17						

SLOW MOVEMENTS

Some of the positions near the end of motion of the vehicle are reached only by means of slow movements to have a safe and uniform reaction of the manoeuvres.

The Diagram below shows the slow motion condition:



- X** - Reference value, depends on movement selected. For example, boom angle or boom length.
- Y** - Actual joystick speed. For example, 50% means that the speed activated by the system is only half that of the joystick.
- 1** - Area in which slow motion is still excluded. The maximum speed is permitted.
- 2** - Quota (angle or length) when the slow motion begins.
- 3** - Area in which slow motion is active. For the same position of the joystick, the speed is reduced while approaching the end of motion.
- 4** - End of slow motion programmed electronically. Beyond this point, the maximum permitted speed is equal to the value at point 5.
- 5** - Maximum permitted speed at the end of the slow motion area. Set as 0 to stop the movement. Set a value higher than the dead band to have minimum speed.

Code	Description
IDS_ALARM502	Pressure High chamber compensation B: Min
IDS_ALARM503	Pressure High chamber compensation B: Max
IDS_ALARM504	Pressure High chamber compensation : Congruency A-B
IDS_ALARM518	Switch err. Stabilize front right:Congruency
IDS_ALARM519	Switch err. Stabilize front left:Congruency
IDS_ALARM520	Switch err. Stabilize rear right:Congruency
IDS_ALARM521	Switch err. Stabilize rear left:Congruency
IDS_ALARM522	Switch err. Outrigger front right: Congruency
IDS_ALARM523	Switch err. Outrigger front left:Congruency
IDS_ALARM524	Switch err. Outrigger rear right:Congruency
IDS_ALARM525	Switch err. Outrigger rear left:Congruency
IDS_ALARM527	Overload condition 1
IDS_ALARM528	Overload condition 2
IDS_ALARM529	Overload condition 3
IDS_ALARM530	Fault condition output Pin [Pin - Extra CutOff]
IDS_ALARM531	Extra CutOff From LMI
IDS_ALARM532	LMI: By-Pass Key activated
IDS_ALARM536	Can bus time out from Tools Recognition
IDS_ALARM537	Fault from Tools Recognition: Blk
IDS_ALARM538	Fault from Tools Recognition: Error Code

P04: Boom	
a AA.A BB.B CC.C I DD.D EE.E FF.F	LMI and vehicle unit boom angles and lengths Top row: AA.A: LMI angle BB.B: vehicle angle CC.C: angular difference between LMI and vehicle Bottom row: DD.D LMI length EE.E vehicle length FF.F: length difference between LMI and vehicle
P05: stabilizers	
Stb AAA BBB CCC DDD	stabilizers percentages AAA: forwards to the LH BBB: forwards to the RH CCC: backwards to the LH DDD: backwards to the RH
P06: Rotax	
Rot AAAA BBBB CCCC DDDD EEEE	AAAA: turret angle BBBB: error code from rotax CCCC: angle 1 from rotax DDDD: angle 2 from rotax EEEE: angular difference from rotax (angle 1- angle 2)
P07: Levelling	
Liv T:XXXX SXX E:XX L:XXXX	Chassis inclinations T: transverse L: longitudinal S: status E: error
P09:	
N/U	Not used
P10: Lift boom	main boom lift movement
So 111 222 333	111: sample joystick 0 +/- 1000 222: speed percentage determined by joystick 333: Danfoss control (0 – 1024)
P11: telescopic	telescopic boom motion
Sf 111 222 333	111: sample joystick 0 +/- 1000 222: speed percentage determined by joystick 333: Danfoss control (0 – 1024)
P12: Forks	fork motion
Fo 111 222 333	111: sample joystick 0 +/- 1000 222: speed percentage determined by joystick 333: Danfoss control (0 – 1024)
P13: Slewing	slewing motion
Ro 111 222 333	111: sample joystick 0 +/- 1000 222: speed percentage determined by joystick 333: Danfoss control (0 – 1024)

A list of angle and length values in certain control points is given below.

Boom angles	ACT 1A	ACT1B
Boom closed 0°	1800	1800
Boom open 80°		
Boom length	ACT 1A	ACT1B
Boom closed		
Boom open		
Boom angle	ACT 2A	
Boom closed 0°		
Boom open 80°		
Boom length	ACT 2A	
Boom closed		
Boom open		

EXTENSION AND ANGLE CALIBRATION

This operation consists in the automatic self-calibration of the boom angle and extension sensors in IN/OUT and UP/DOWN conditions.

SENSORS SELF-CALIBRATION IN VEHICLE CLOSED CONDITIONS

A00 S 6.8 W.0 12 Transd. Min	Position the vehicle with the booms completely retracted. Use the "+" and "-" keys to browse through the page shown here. Press ENTER and INDEX to confirm the calibration in "vehicle closed" condition. Check to make sure the angle and extension values displayed are correct. Then proceed with self-calibration of sensors in "vehicle open" condition.
---------------------------------	---

SENSORS SELF-CALIBRATION IN VEHICLE OPEN CONDITIONS

A00 S 6.8 W.0 13 Transd. Max	Extend the booms completely making sure the two lift cylinders and extension are at the end of travel. In this condition the angle and extension readings correspond to the values saved in memory. Use the "+" and "-" keys to browse through the page shown here. Press ENTER and INDEX to confirm the calibration in "vehicle open" condition.
---------------------------------	---

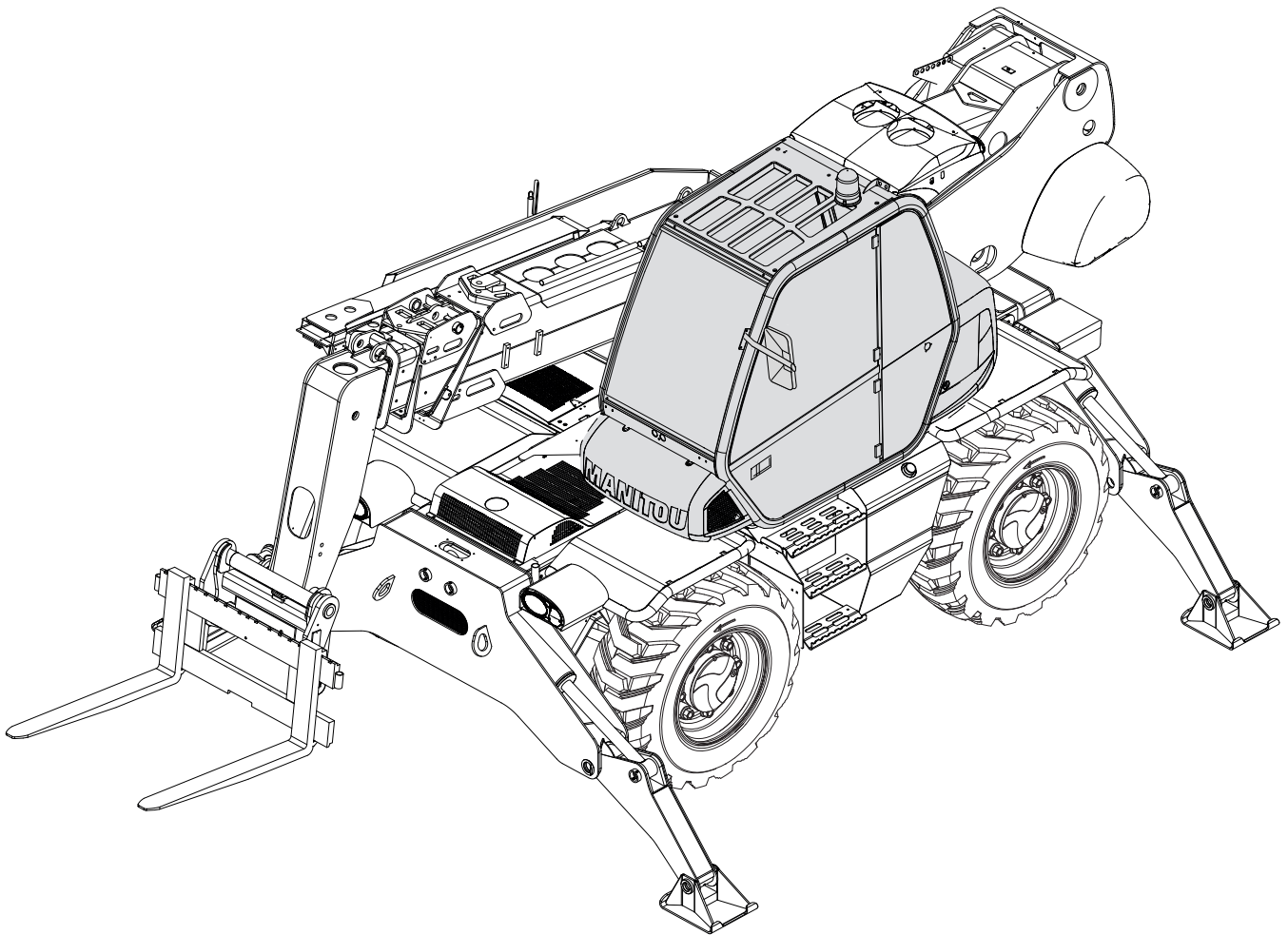
INITIALIZATION OF CALIBRATION PROCEDURE

Following the Load Table for activation of the accessory to be used, first of all check to make sure the load weight value on the display corresponds to some of the loads lifted with known weight.

If the value exceeds the 10% tolerance, it is advisable to refine the calibration starting with this "initialization".

A00 S 6.8 W.0 26 INITIAL WEIGHT	Use the "+" and "-" keys to browse through the menu shown here. Press ENTER to enter the accessories configuration
A00 S 6.8 W.0 Index to confirm	Press INDEX to confirm initialization = cancellation of previous calibration

85.1 DRIVER'S CAB REMOVAL



GENERAL INFORMATION

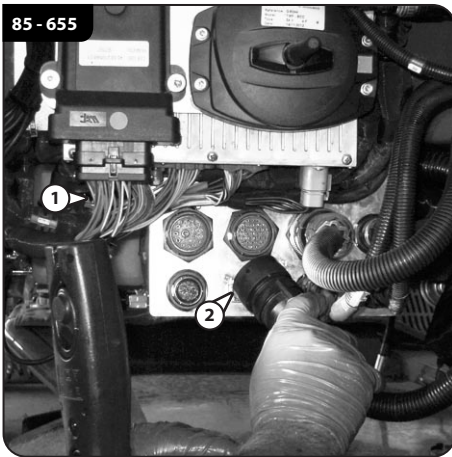
The sequence for disassembly operations must be followed to access the various components. Mark all the hydraulic pipes and electrical connections with a marker pen, before disassembling, to ensure correct positioning in the reassembly phase.



⚠ Discharge pressure from the hydraulic circuit before disconnecting the tubes. Plug all the hydraulic pipes and orifices to prevent impurities from contaminating the hydraulic circuit.

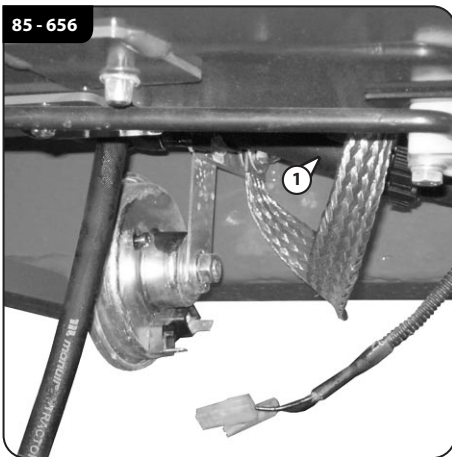
PREPARATION AND SAFETY INSTRUCTIONS

Specific tooling:

- Crane for lifting (5000 kg. minimum).



Reconnect the connectors (1,  85 - 33) on the control unit. Reconnect the electric bulkhead connectors (2,  85 - 33) present under the cab.

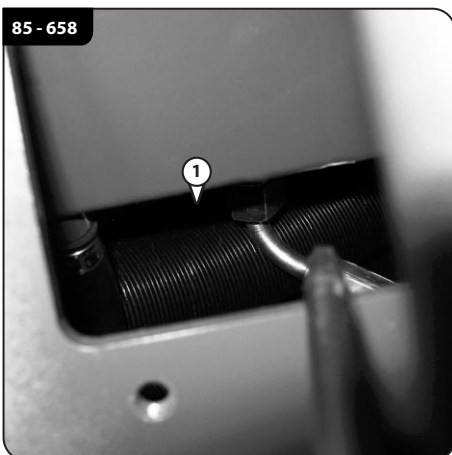



Reconnect the earth wire (1,  85 - 34) of the horn.

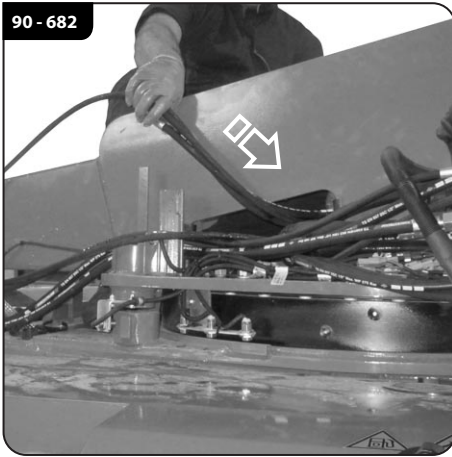
85.2.3 RECONNECT THE CAB HYDRAULIC SYSTEM



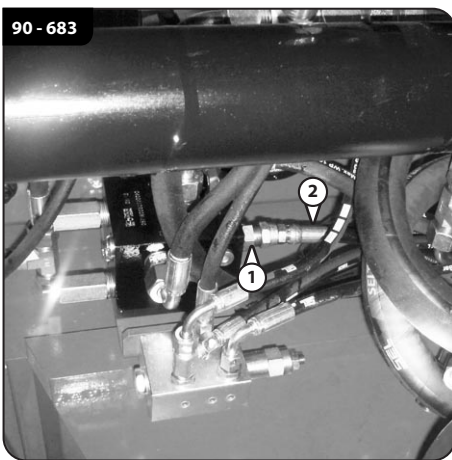
Reconnect the heating pipe (1,  85 - 35) on the outer side to the RH of the cab.





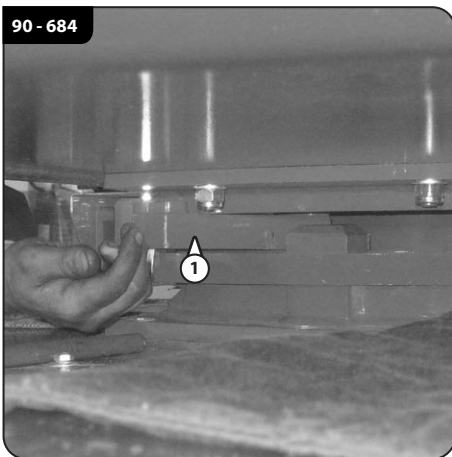
Reconnect the tray drainage tube (1,  85 - 36) of the brakes inside the cab.




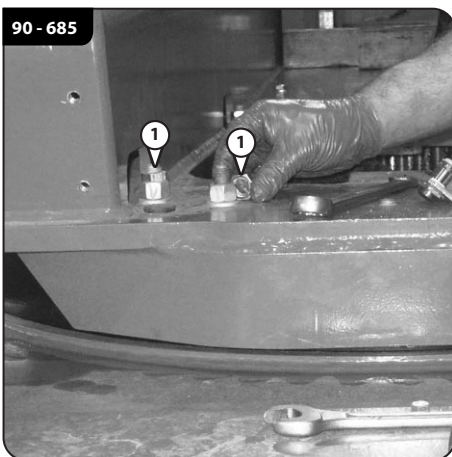
Remove the pipes through the slot on the turret.



Disconnect all the tubes from connectors (1,  90 - 13) on the rotation valve and connect the tubes (2,  90 - 13) of the hydraulic control unit to these.



Remove the block (1,  90 - 14) for rotation of the turret (only the 400° version).



Unscrew lock nuts (1,  90 - 15).

CLICK HERE TO **DOWNLOAD** THE COMPLETE MANUAL

- Thank you very much for reading the preview of the manual.
- You can download the complete manual from: www.heydownloads.com by clicking the link below



- Please note: If there is no response to CLICKING the link, please download this PDF first and then click on it.

CLICK HERE TO **DOWNLOAD** THE COMPLETE MANUAL