

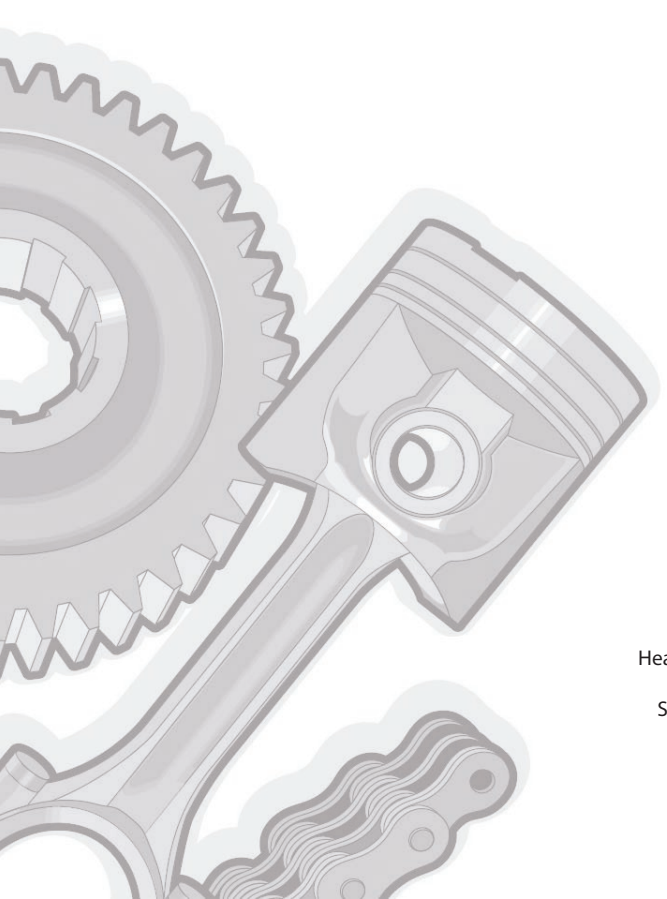

**REPAIR MANUAL
MANUEL DE RÉPARATION
REPARATURANLEITUNG
MANUAL DE REPARACIÓN
MANUALE RIPARAZIONE**

This document has been printed from  myedoc



MANITOU BF

Head office: 430, Rue de l'Aubinière
44150 Ancenis - FRANCE
Share capital: 39,548,949 euros
857 802 508 RCS Nantes
Tel: +33 (0)2 40 09 10 11
www.manitou.com

CLICK HERE TO **DOWNLOAD** THE COMPLETE MANUAL

- Thank you very much for reading the preview of the manual.
- You can download the complete manual from: www.heydownloads.com by clicking the link below



- Please note: If there is no response to CLICKING the link, please download this PDF first and then click on it.

CLICK HERE TO **DOWNLOAD** THE COMPLETE MANUAL

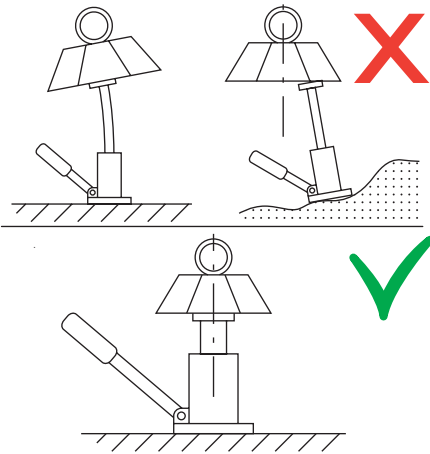

When lifting or shoring a component of the machine, make sure the equipment used is suitable for at least the load for which it is subjected by the component and that it meets the national standards for lifting devices.

When using a jack, make sure it is used on a flat, uniform surface, is sturdy enough to support the load, that its lifting capacity is sufficient and that it is correctly placed and positioned under the machine.

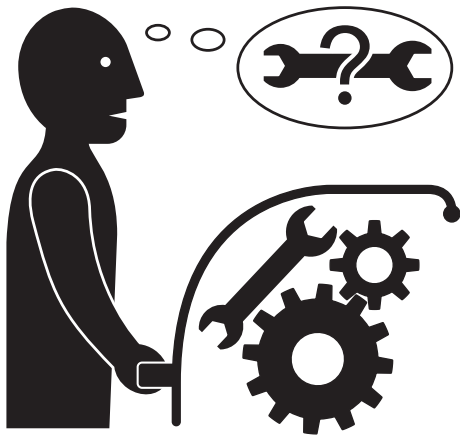

Make sure no object or tool which could cause an accident is left in the machine.



Never control any leaks using a hand.

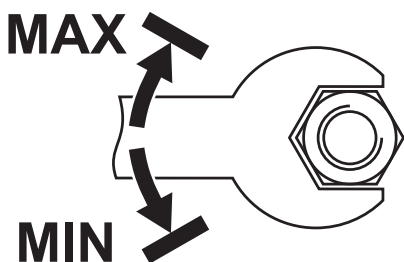
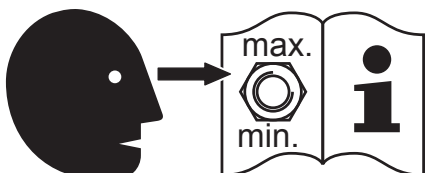

Never adjust a component to over the maximum capacity indicated by the manufacturer.

ELECTRONIC CONTROL MODULE

The MR2-PLD electronic control module (1) is the regulator and computer for the fuel circuit. The MR2-PLD receives signals from the sensors to control the engine's tuning and speed.

The electronic circuit is made up of the MR2-PLD, sensors on the engine and inputs from the whole of the machine by the ADM2 (2) located in the cab. The MR2-PLD is the computer. The personalization module is the computer software. The personalization module contains the performance curves.

The performance curves define the following characteristics of the engine:

- Engine power
- Torque curves
- Engine rate (RPM)
- Engine noise
- Exhaust and emissions

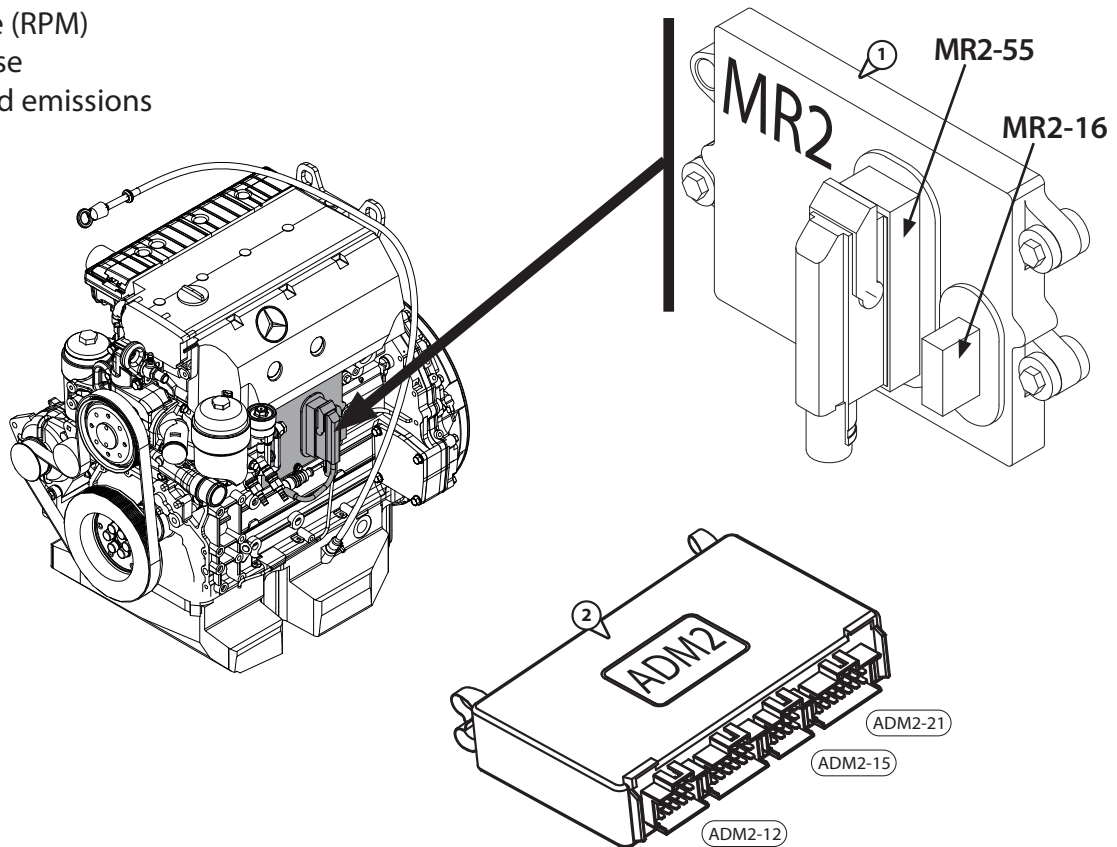

ENGINE GROUND

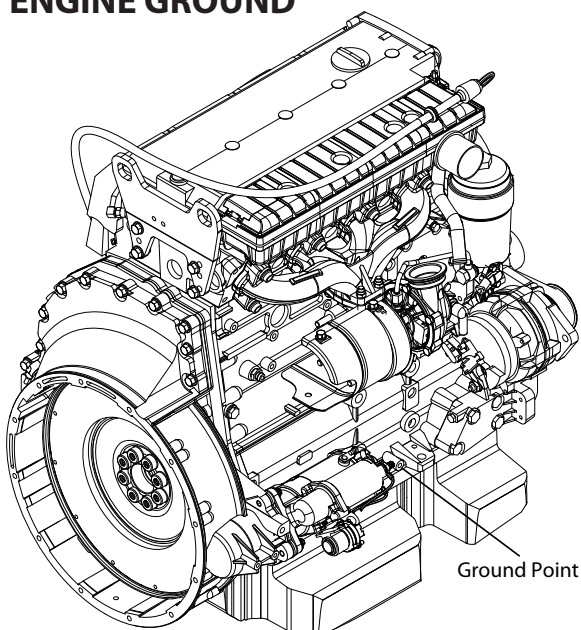

ENGINE COMPONENTS REMOVAL AND REFIT

10

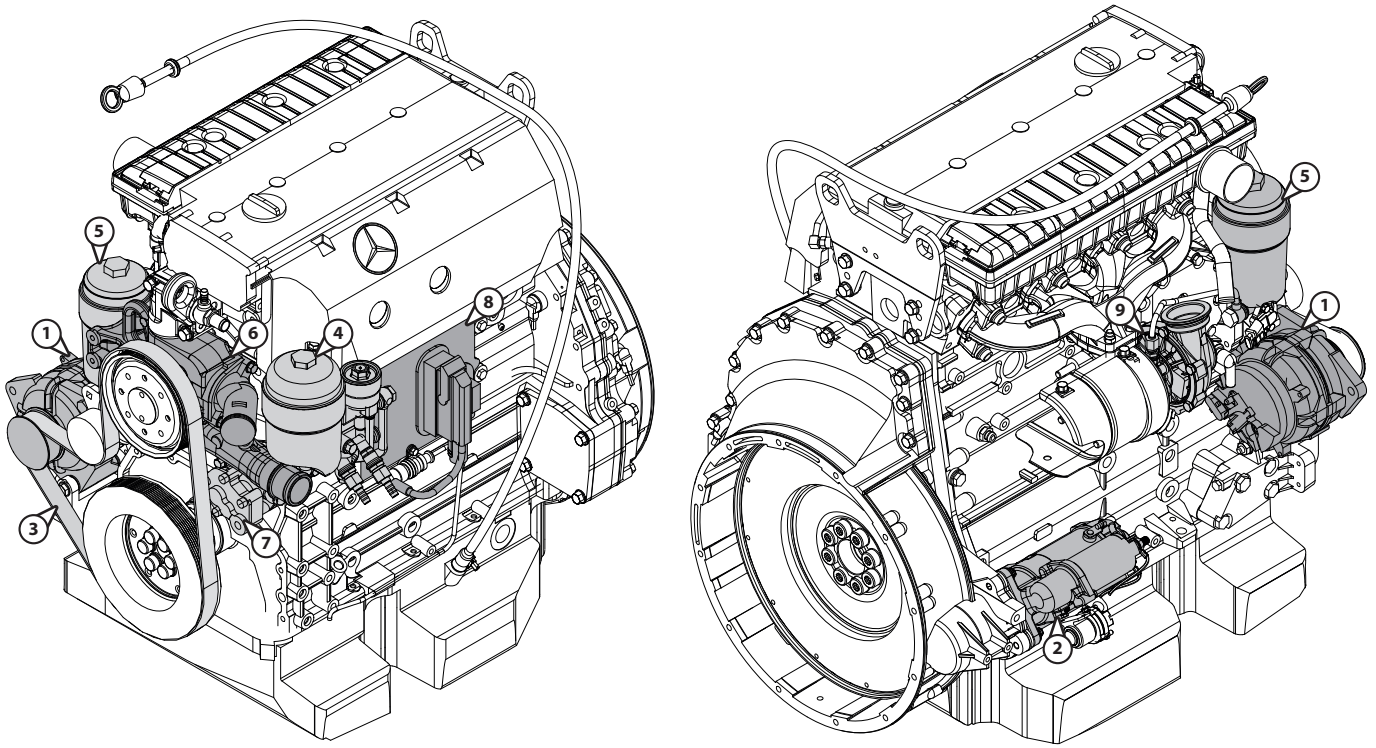

Key:

- 1 - Alternator
- 2 - Starter
- 3 - Belt
- 4 - Fuel fi lter
- 5 - Oil fi lter
- 6 - Water pump
- 7 - Fuel pump
- 8 - PLD
- 9 - Turbocompressor

PREPARATION AND SAFETY INSTRUCTIONS

- Activate battery cut-out.
- Open I.C. engine cover.
- Use battery cut-out to deactivate power supply.

Graph showing Fan Drive operating cycle

10

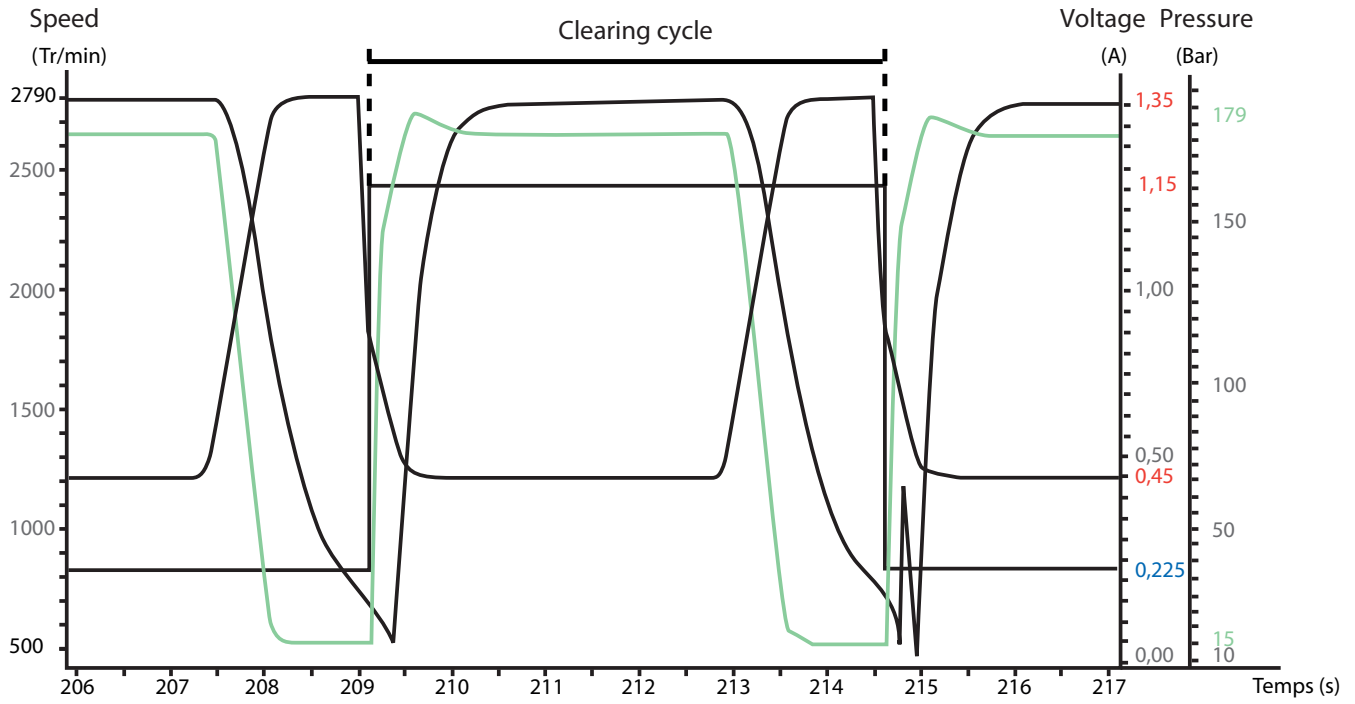

- Key:
- Control voltage
 - Changeover voltage
 - Fan circuit pressure
 - Fan speed

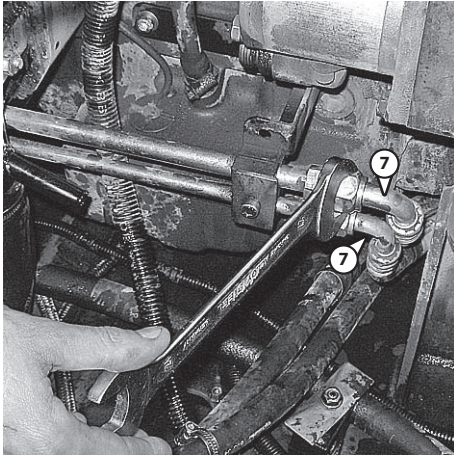

Empty the air conditioning circuit, then remove its hoses (Item 7) using a 27 mm spanner.

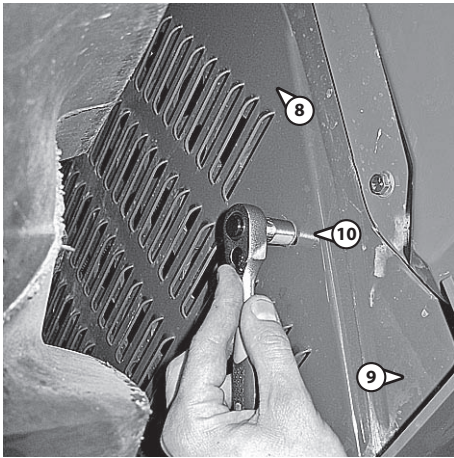

Remove the protective cover (Item 8) from the back of the engine bay (Item 9), unscrewing the bolts (Item 10) with a 10 mm spanner.

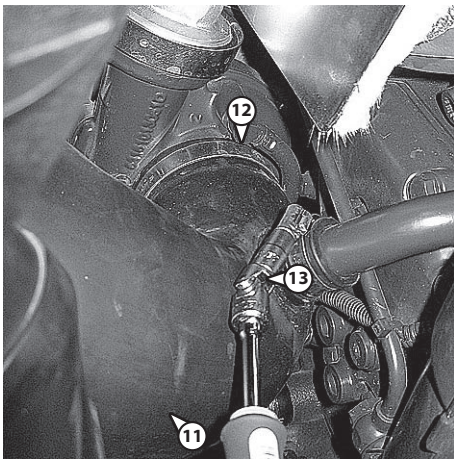

Remove the air inlet hose (Item 11), unscrewing the three hose clips (Item 12) with a 7 mm spanner.

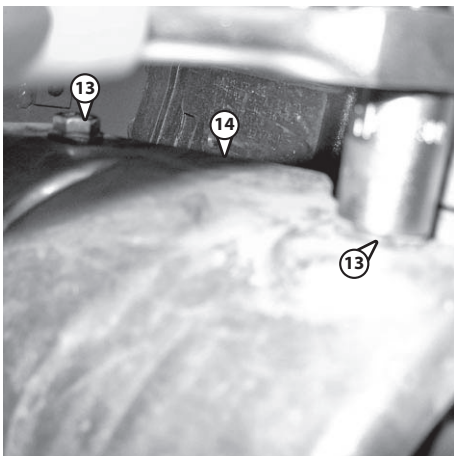

Remove the four fixing bolts (Item 13) from the protective grille (Item 14) between the compensator and the turbo, using a 13 mm spanner.
Remove the protective grille.

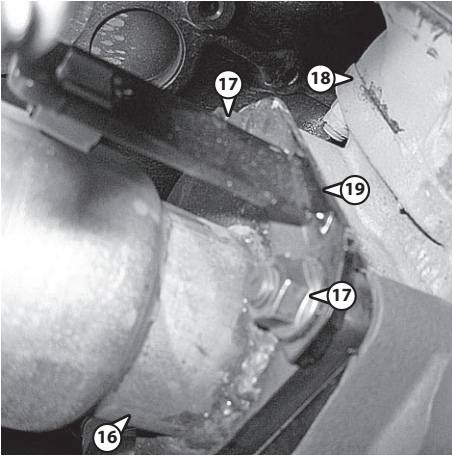

Fit the compensator (Item 16). Fix the four fixing bolts (Item 17) behind the turbo (Item 18), without forgetting the protective grille's fitting lug (Item 19).

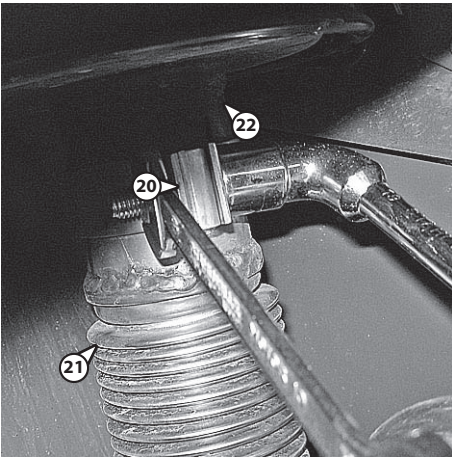

Fit the clamp (Item 20) between the compensator (Item 21) and the exhaust system (Item 22).

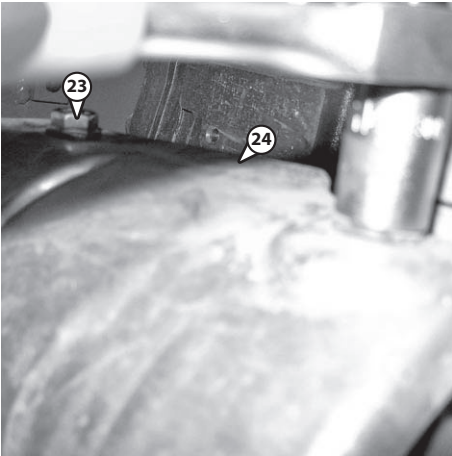

Fit the compensator protective grille (Item 23); Tighten the four bolts (Item 24) with a 13 mm spanner.

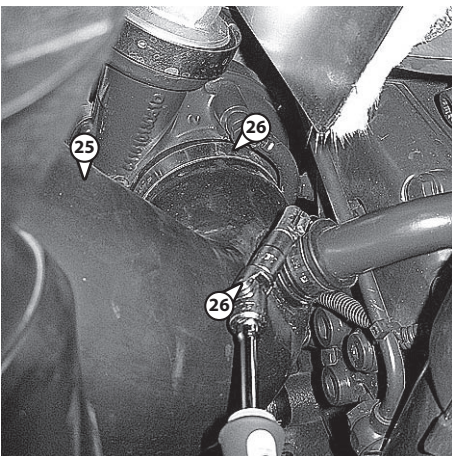

Re-fit the air intake hose (Item 25) between the filter and the turbo; secure it with the three hose clips (Item 26) and tighten with a 7 mm spanner.

OPERATING PRINCIPLE

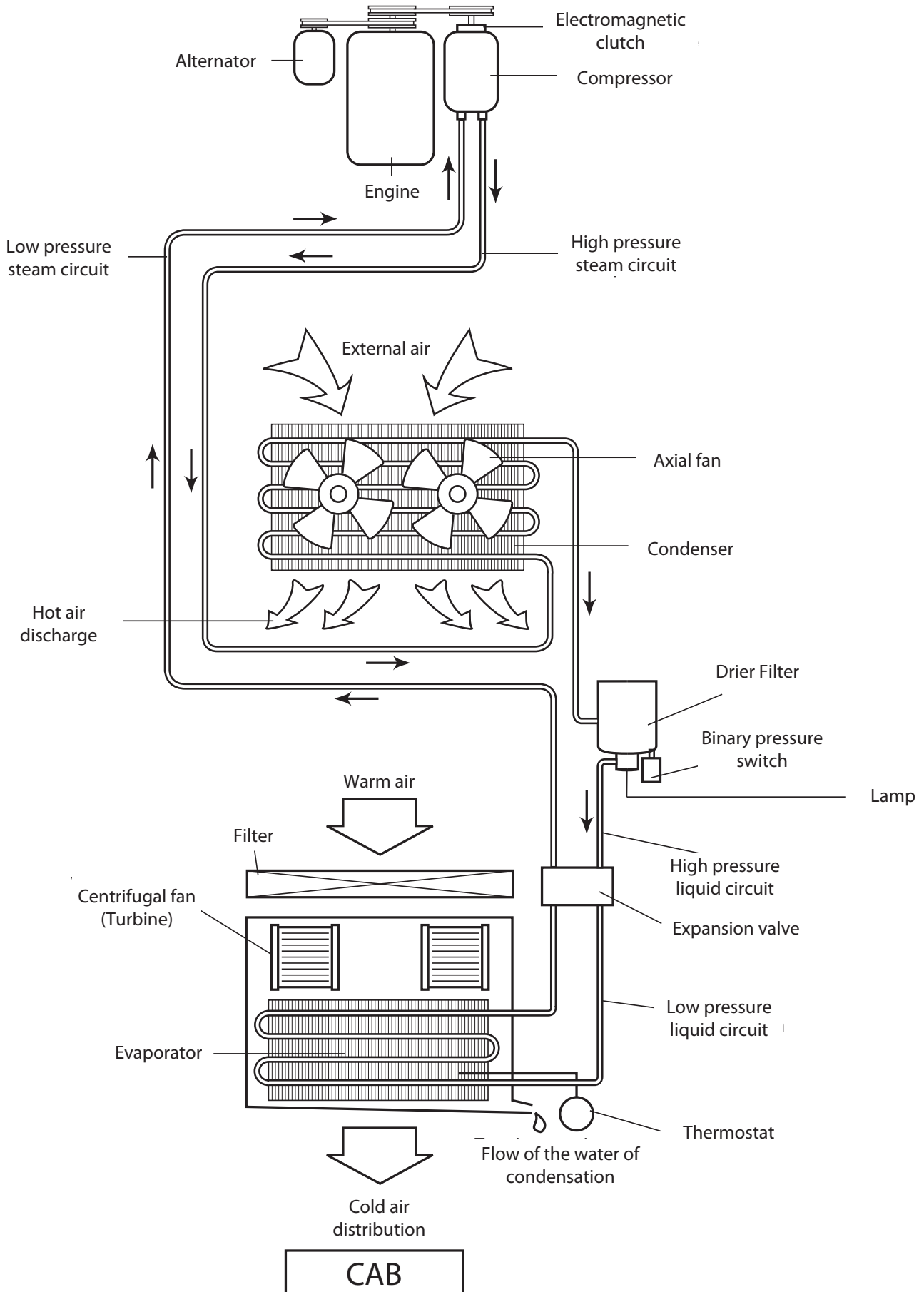

Standard tightening torque to be used when no mention is made in the dismantling and re-assembly instructions.

- (*)
- Tightening torques are given for black or zinc finish fasteners with light lubrication.
 - Tightening torques are given for automatic slip and reset torque wrenches and direct read dial torque wrenches.
 - For more information, consult French Standard NF E25-030.

Tightening torque in Nm (*)					
Thread Ø	Class 5.6	Class 5.8	Class 8.8	Class 10.9	Class 12.9
M3	0,54	0,76	1,16	1,7	2
M4	1,24	1,74	2,66	3,91	4,57
M5	2,47	3,46	5,2	7,7	9
M6	4,29	6	9,1	13,4	15,7
M8	10,4	14,6	22	32	38
M10	20	28	44	64	75
M12	35	49	76	111	130
M14	57	79	121	178	209
M16	88	124	189	278	325
M18	122	171	261	384	449
M20	173	243	370	544	637
M22	238	334	509	748	875
M24	298	418	637	936	1095
M27	442	619	944	1386	1622
M30	600	840	1280	1880	2200

REGULATION END MONITORING AND SETTING

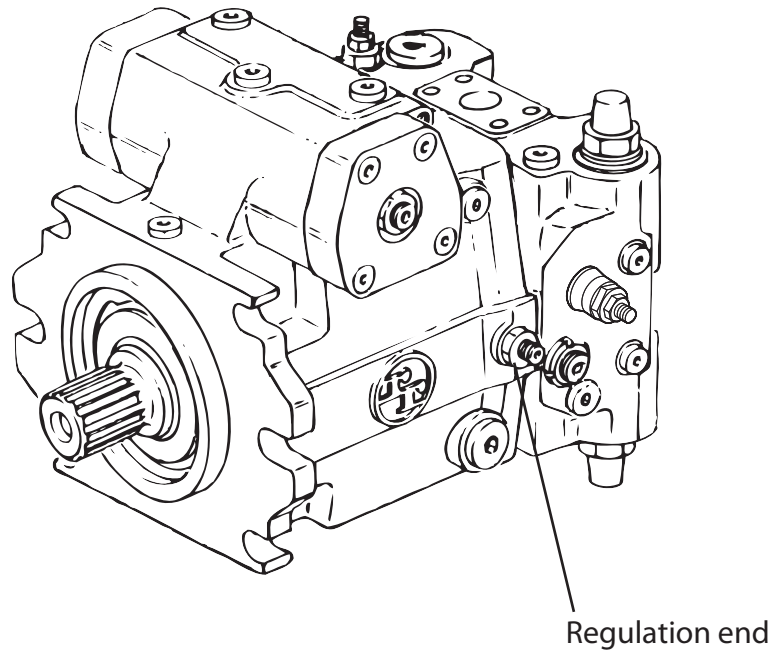

Setting the pump regulation end point at 1700 rpm is done by turning the eccentric screw that varies the port plate setting (shifting by rotation). This has the effect of increasing or reducing the reactive forces on the inclinable plate.



This setting is done on the workshop bench. There is no need for the setting to be retouched.

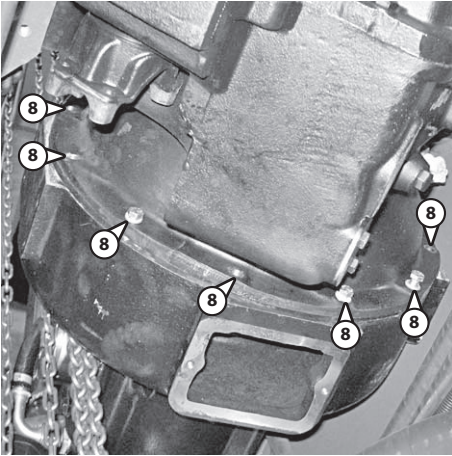

Remove the twelve retaining screws (Item 8) between the angle gear box and the gear box using a 14 mm spanner.

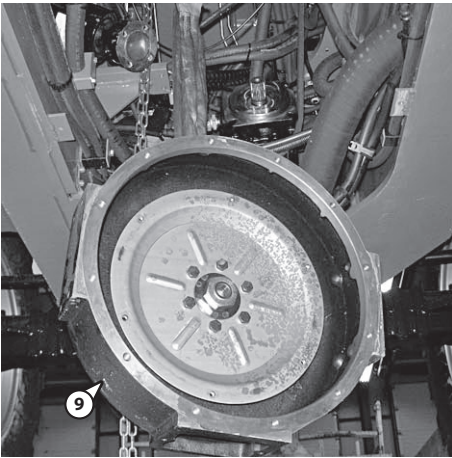

Lower the angle gear box (Item 9), verifying that nothing touches during lowering.

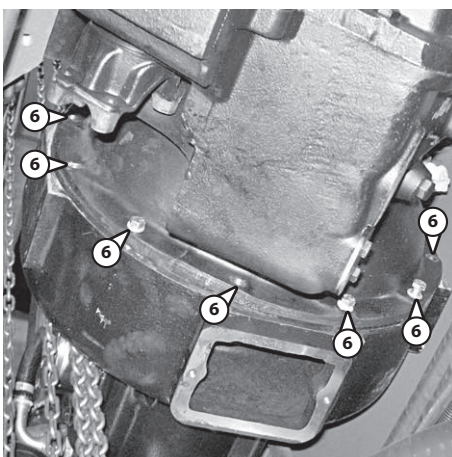
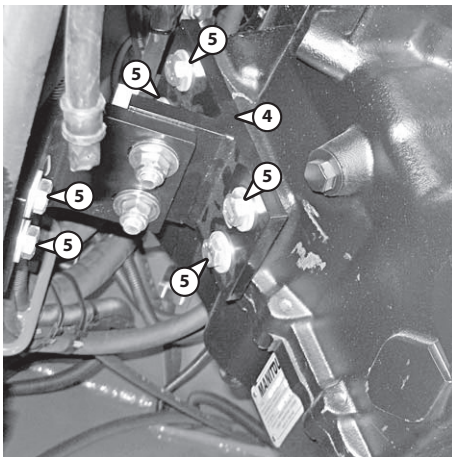
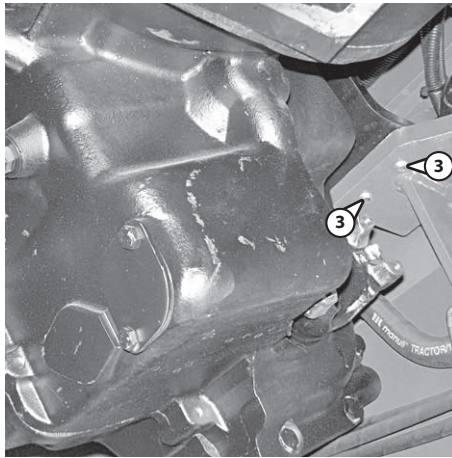
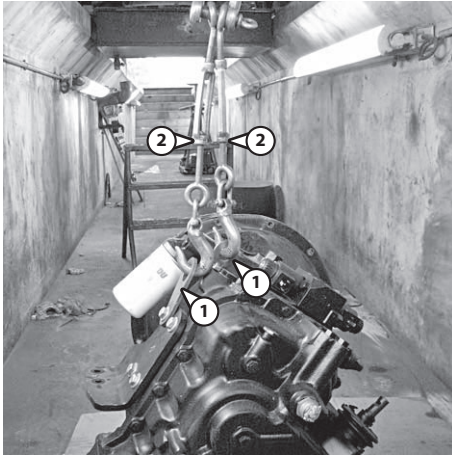

GEAR BOX

GEAR BOX REMOVAL

Install the lifting rings (Item 1) on the gear box.
Place the angle gear box under the carriage.
Install the tie rods (Item 2) on the gear box and install a pulley.

Lift the gear box using the pulley and align the gear box with the angle gear box.

Fasten the gear box to the rated engine frame (two screws) (Item 3) using a 19 mm spanner.

Fasten the support bracket (Item 4) to the gear box and the rated cab frame (six screws) (Item 5) using a 19 mm spanner.

Align the gear box with the angle gear box, then tighten the twelve retaining screws (Item 6) using a 14 mm spanner.

TIGHTENING TORQUE

AXLE

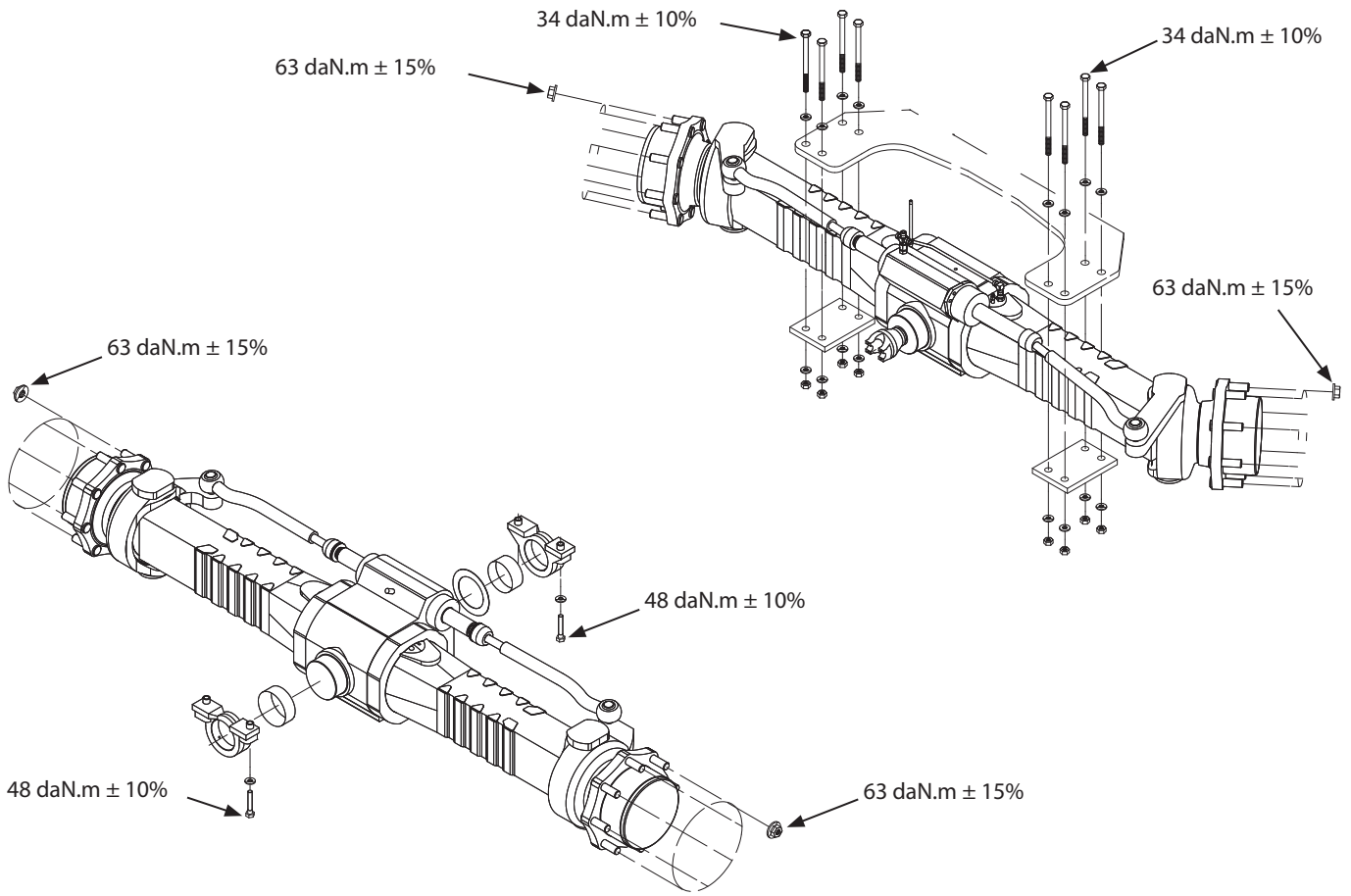

30

MLT 845 SERVICE BRAKE**SETTING BRAKE PEDAL HEIGHT****1) - BRAKE PEDAL**

- Adjust the height of the brake pedal (A) to 95 mm in relation to the cab floor (without carpet) using the stop (B).
- Tighten the locknut E.
- Adjust the brake pedal free play (A) (3 to 4 mm play) by turning the push rod (C)
- Tighten the locknut (D).

2) - TRANSMISSION CUT-OFF SWITCH

- Pedal at rest (touching the stop (B)).
- Move the switch mounted on its bracket (F) so that it is resting on the brake pedal arm (A), ensuring 41 mm free play. Pre-tighten the switch support fixing screws.
- Adjust the position of the switch (F) so that the transmission cut-off is activated when the pedal is 85 mm above the cab floor (see diagram).

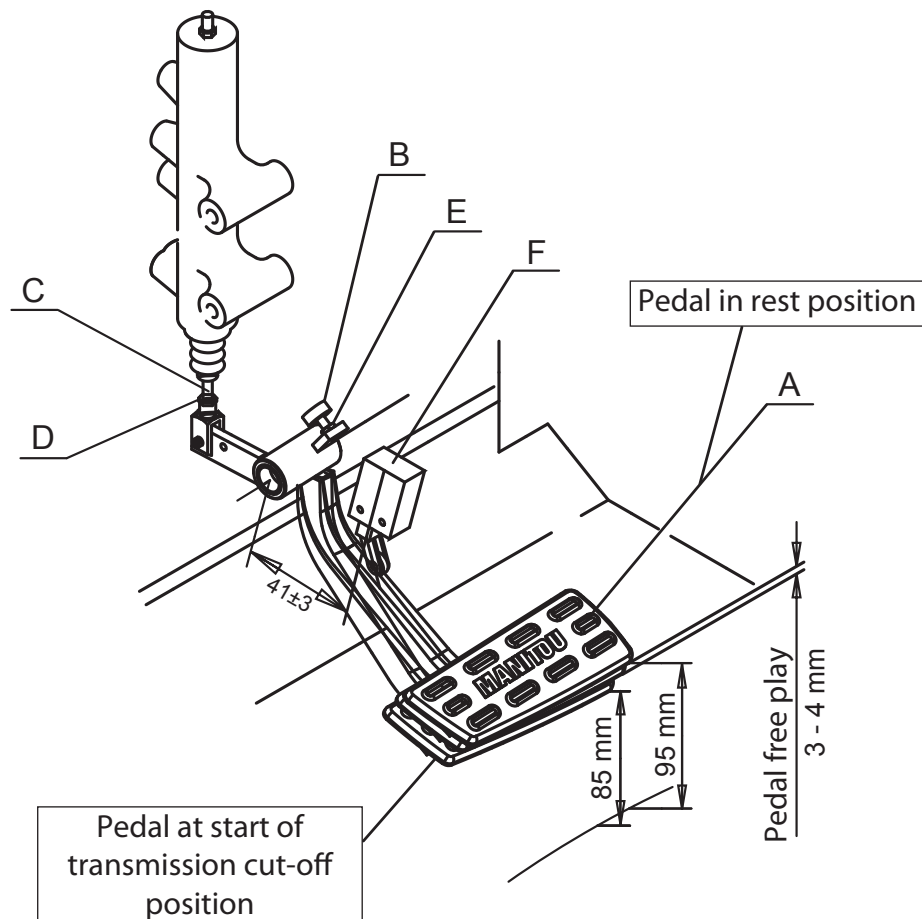

COMPONENT CODE INDEX

Item	Designation
CSP	Piloted safety valve
T1	Telescope 1
VI	Tilt cylinder
VT	Telescoping cylinder

LOCATIONS OF THE MAIN COMPONENTS OF THE 8M BOOM

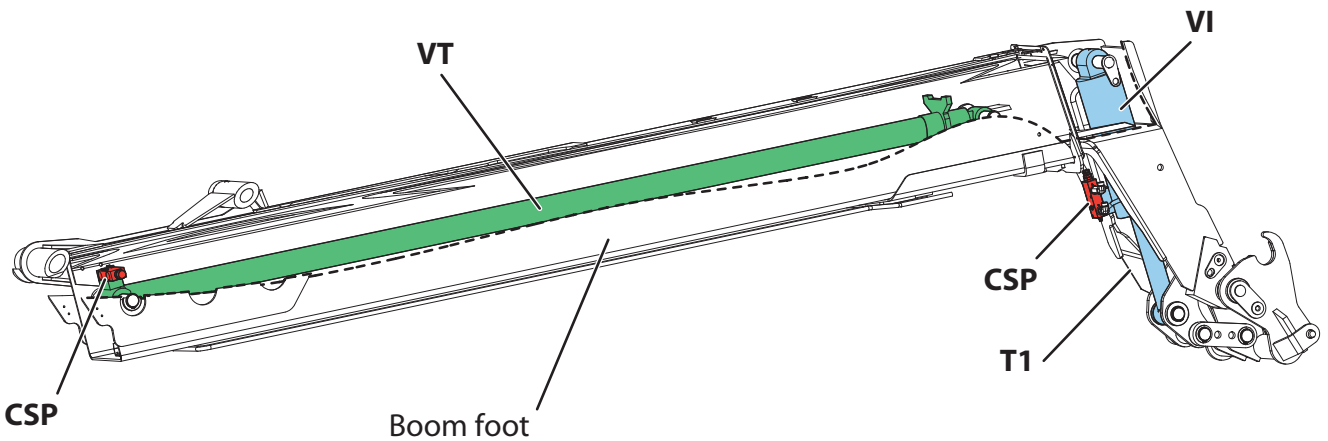
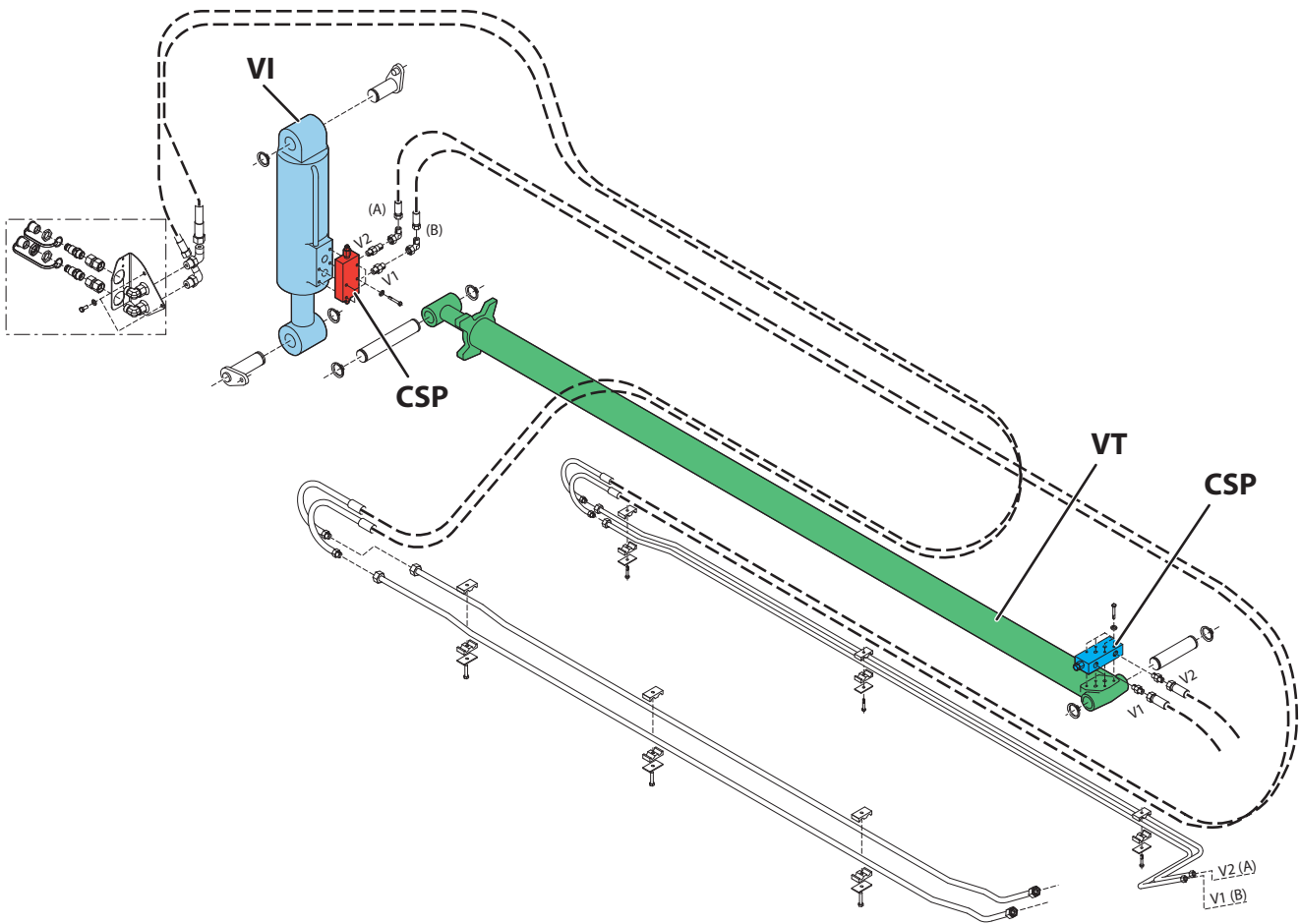

DUPLEX BOOM

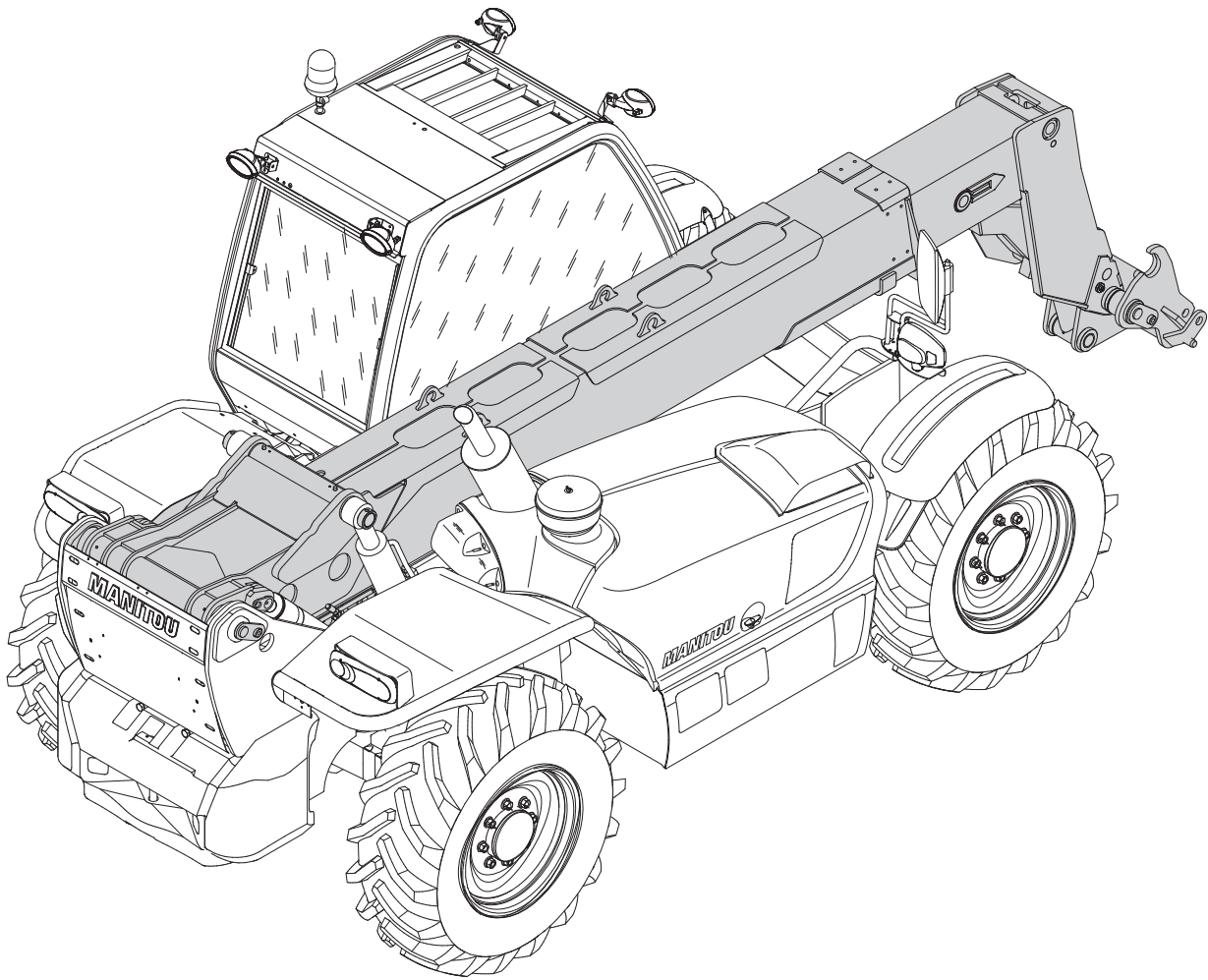

50

PREPARATION AND SAFETY INSTRUCTIONS

- Stabilise the machine on a horizontal floor.
- Fully retract the telescope.
- If an attachment is mounted on the carriage, remove it.
- Position the boom on an axle stand in order to keep it horizontal.
- Decompress all hydraulic elements.
- Deactivate the battery power supply using a battery cut-off.

Whole boom weight \approx 2 050 kg

Specific tools:

- Lifting crane (minimum 2 500 kg).
- Pulleys
- Axle stand
- Mallet
- Trestles

Values for information purposes only.

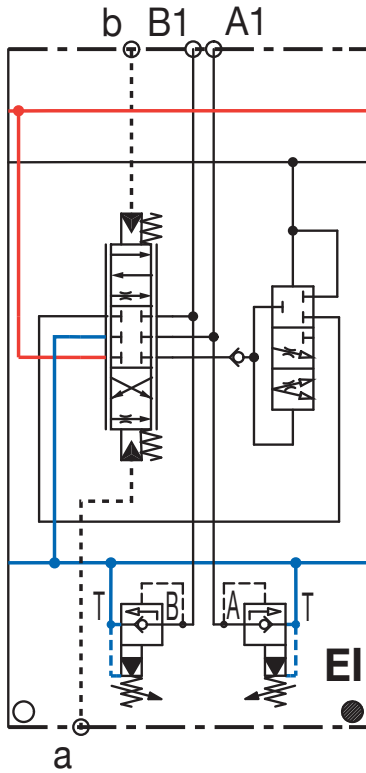

Hydraulic control
(At "rest")

- The hydraulic pressure arrives at the entry module with pump stand-by pressure.
- The Pressure balance ensures communication between the main pressure line through the valveblock to the receiver feed.
- It takes the receiver pressure and communicates it to the pump.
- There is a priority between the receiver feed and pressure information transmission to avoid any rapid pressure increase as a result of a delay in slide opening relative to pump control.

70

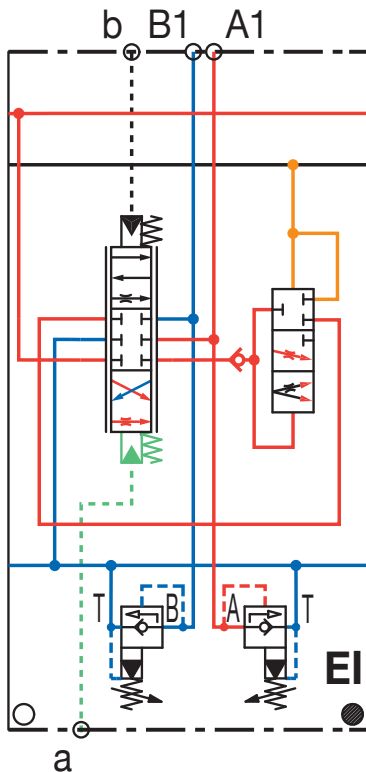

Hydraulic control
(Setting "a")

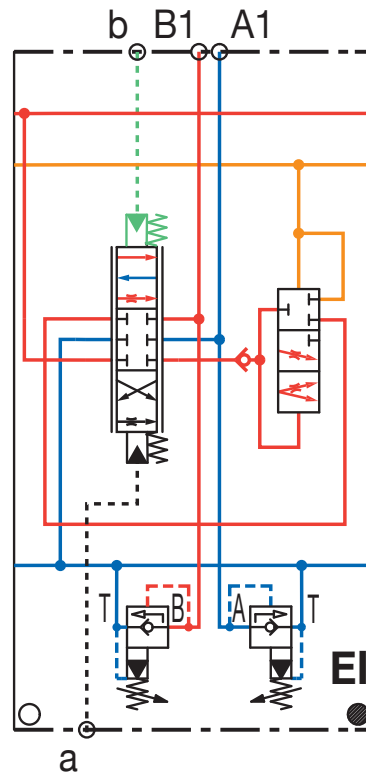

Hydraulic control
(Setting "b")

CLICK HERE TO **DOWNLOAD** THE COMPLETE MANUAL

- Thank you very much for reading the preview of the manual.
- You can download the complete manual from: www.heydownloads.com by clicking the link below



- Please note: If there is no response to CLICKING the link, please download this PDF first and then click on it.

CLICK HERE TO **DOWNLOAD** THE COMPLETE MANUAL

Values indicative only

Flow of fluids

Small displacement position 60%

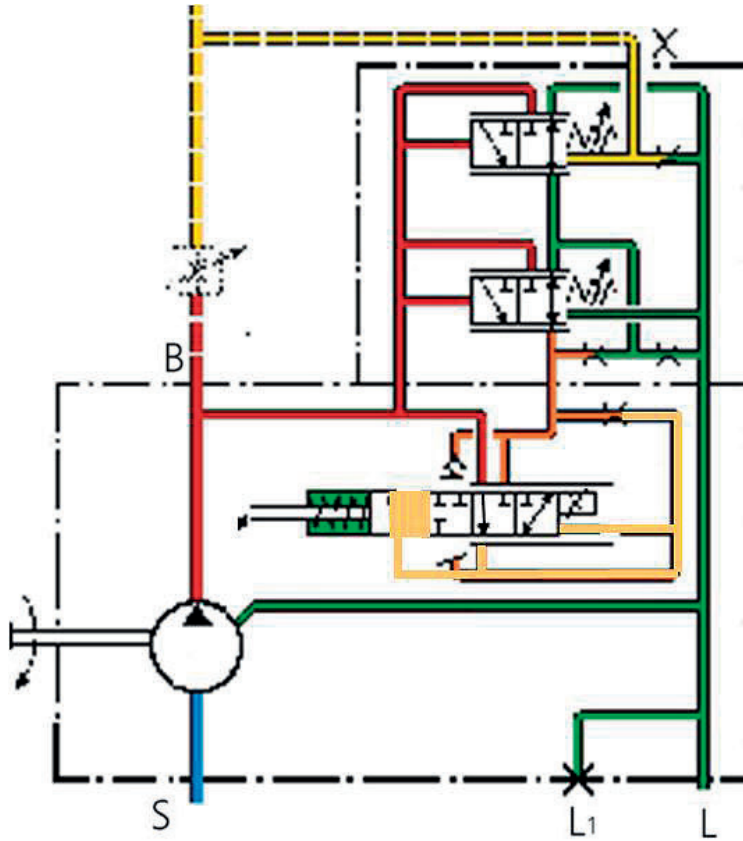

70

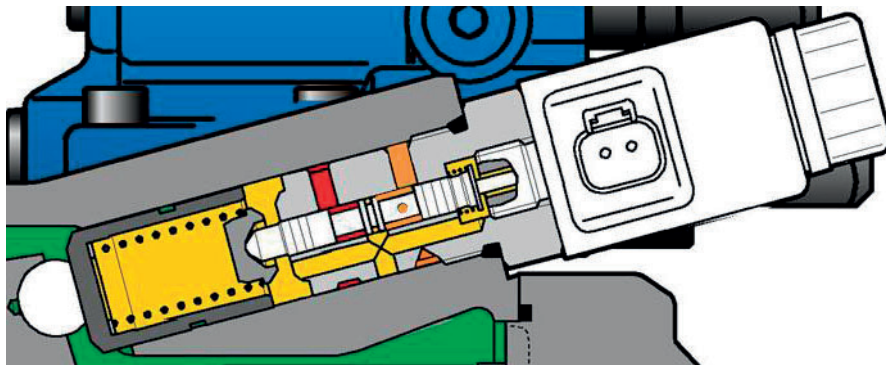

Notes: _____

PRESSURE TAKE-OFF POINTS

VALUES

<i>Machine</i>	<i>N° of pressure ports</i>	<i>Values (bars) Typical</i>
MLT 845-120 H Series 4-E3 MLT 845-120 Series 5-E3	PP-1	270

LOCALIZATION

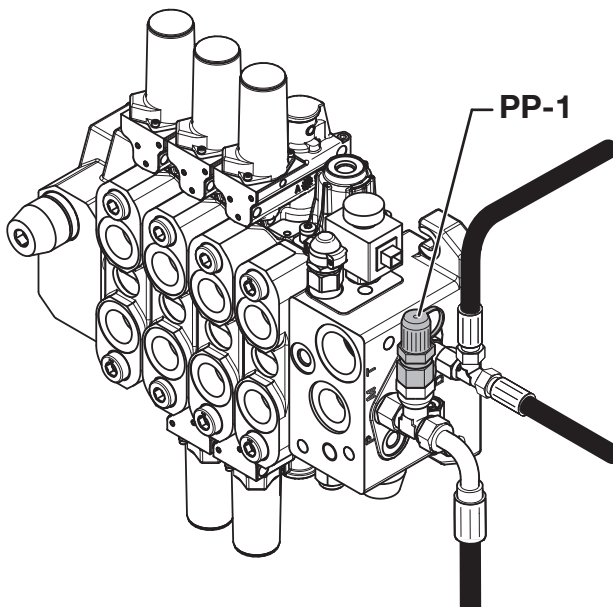

MLT 845-120 H Series 4-E3
MLT 845-120 Series 5-E3

5.3 DIS-ASSEMBLY OF FLOW DIVIDER REGULATION SUB-ASSEMBLY

NOTE: It is not necessary to remove the distribution unit from the machine to change the limiter.

- !** *With the machine stopped:*
- Put all the machine's receivers connected to the distribution unit in their rest positions.
 - With the machine stopped, release all stored pressure by moving the distribution slides.

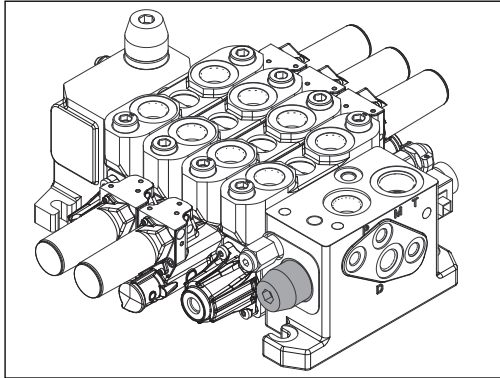

NOTE:

- Attach a vacuum pump to the tank to limit the escape of oil during this operation.
- Catch any leaked oil in an appropriate container.
- Remove the plug (12 mm Allen key)
- Remove the stop and the spring.

Refitting: tightening torque: cf. § 6.

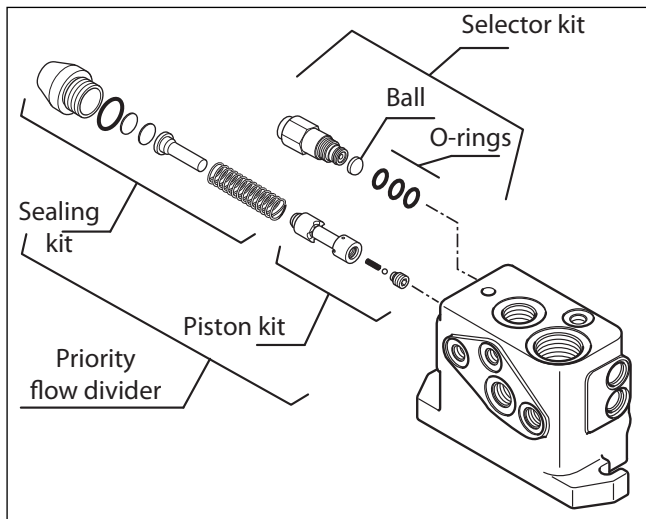

- Replace any defective parts.
- Replace the O-rings on the plugs.
- Re-assembly is the reverse of dis-assembly.

5.4 FLUSHING VALVE REMOVAL

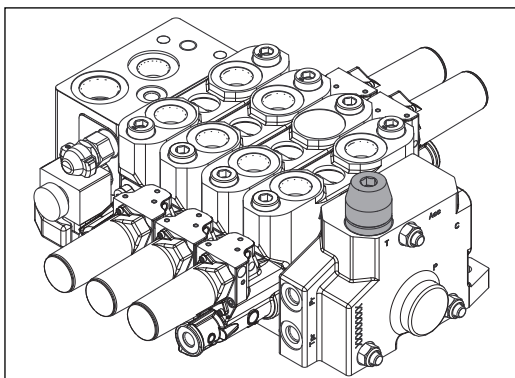

NOTE: There is no need to remove the control block from the telehandler for this operation.



- Telehandler switched off:**
- Place all actuators connected to the control block in their rest position.
 - Release all stored pressure by moving the distribution slides.



Remove the distributor (Item 26).

KEY KEY OPERATED STARTER SWITCH

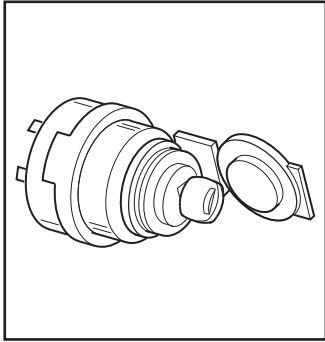

		PIN	Function
<p>X54</p>	1	+ Battery	
	2	+ Battery	
	3	Not used	
	4	Preload shunt	
<p>X55</p>	5	+ Post contact (+APC)	
	6	+ Post contact (+APC)	
	7	Starter	
	8	Preheating Shunt	
	9	Preheating relay control	
	10	Not used	

Corresponding connector

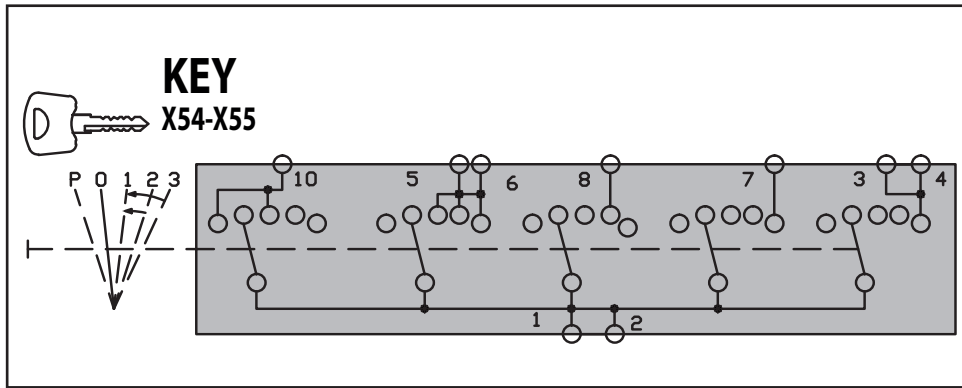

Diagram

	PIN	Minimum	Typical	Maximum
Switchable current		/	8 A	/
On line drop		/	300 mV	/

Notes: _____

X14 HORN

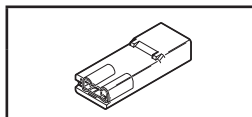
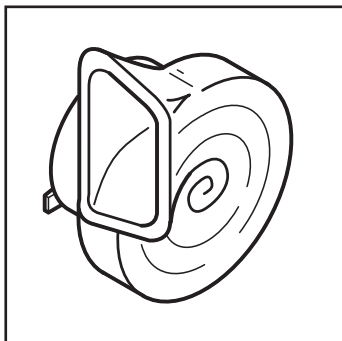

Corresponding connector

PIN	Function
1	Horn power supply

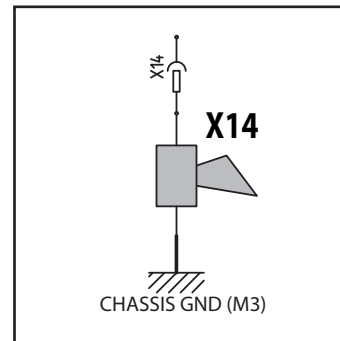

Diagram

	PIN	Minimum	Typical	Maximum
Supply voltage		9 V	12 V	15 V
Resistance (10%)		/	2,17 Ω	/
Nominal frequency			500 \pm 20 Hz	
Average current			6 A	

Note:
- Sound level 107 dB(A) / 13V.

Notes: _____

X15+X21 WHEEL ALIGNMENT SENSOR

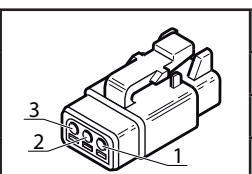
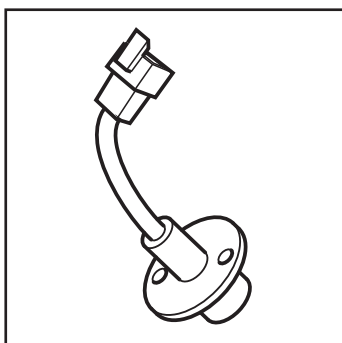

Corresponding connector

PIN	Function
A	Signal
B	Power supply
C	Ground

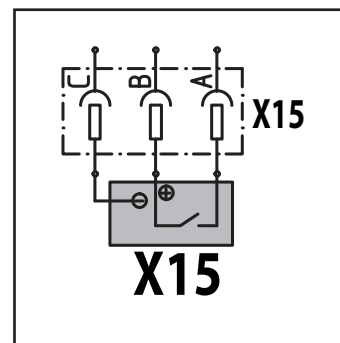

Diagram

	PIN	Minimum	Typical	Maximum
Supply voltage		/	12 V	/
Direct current		/	10 mA	/
Outlet logic		Switch closed = wheels aligned		
Type of outlet		PNP at Vbat		

Notes: _____

Electrical connectors					
Harness type	Item	Name of component	Designation	Position on diagram	Hydraulic code equivalence
Main	M3	X14	HORN GROUND	G40	
Cab	P09	P09	ROOF WINDSCREEN WIPER MOTOR	Q8	
Cab	P10	P10	REAR WINDSCREEN WIPER MOTOR	Q10	
Cab	P12A	P12A	HEATING	O16	
Cab	P12B	P12B	HEATING	O17	
Main/Electric plate	X04		ELECTRIC PLATE	E7	
Main	X13	X13	FRONT RIGHT HEADLIGHT	Q40	
Main	X14	X14	HORN	G40	
Main	X16	X16	REAR RIGHT HEADLIGHT	Q33	
Main	X17	X17	REAR RIGHT HEADLIGHT	Q27	
Main	X19		REAR TRAILER CONNECTOR (OPTION)	K29	
Main	X20	X20	REVERSING SOUND ALARM (OPTION)	O29	
Main/Cab	X26		MAIN/CAB INTERFACE	M9	
Main	X30	X30	HEATING FAN SWITCH	I24	
Main/Electric plate	X39		ELECTRIC PLATE	G33	
Main/Electric plate	X41		ELECTRIC PLATE	E40	
Main/Electric plate	X45		ELECTRIC PLATE POWER SUPPLY (KEY SWITCH)	A4	
Main	X70	M3	WINDSCREEN WASHER PUMP	Q23	
Main	X73	S16	BRAKE CIRCUIT PRESSURE SWITCH	O26	
Main	X74	X74	FRONT LEFT HEADLIGHT	Q35	
Main	X77	X77	FRONT WINDSCREEN WIPER MOTOR	Q20	
Main	X79	X79	FRONT WINDSCREEN WIPER SWITCH	M24	
Main	X149	X149	REAR AND ROOF WINDSCREEN WIPER SWITCH	K24	
Main	X150	X150	REVOLVING LIGHT SWITCH	G4	
Main	X151	X151	FRONT AND REAR WORKING LIGHT SWITCH	K4	
Main	X154	V5	DIODE POSITION LIGHT / WORKING LIGHTS	G30	
	X155	V5	DIODE POSITION LIGHT / WORKING LIGHTS	G32	
Electric plate	X188	X188	LIGHT COMMUTATOR SWITCH	C36	
Main/Electric plate	X308		ELECTRIC PLATE	E18	
Main	X329	F33	WORKING LIGHTS FUSE	C4	
Main	X330		WORKING LIGHT ON BOOM (OPTION)	E4	

Electrical components			
Item	Designation	Position on diagram	Hydraulic code equivalence
V5	DIODE POSITION LIGHT / WORKING LIGHTS	G31	
V6	DIODE	E34	
X13	FRONT RIGHT HEADLIGHT	Q40	
X14	HORN	G40	
X16	REAR RIGHT HEADLIGHT	Q33	
X17	REAR RIGHT HEADLIGHT	Q28	
X18	REAR LICENSE PLATE LIGHT	O33	
X20	REVERSING SOUND ALARM (OPTION)	O29	
X30	HEATING FAN SWITCH	I24	
X74	FRONT LEFT HEADLIGHT	Q35	
X77	FRONT WINDSCREEN WIPER MOTOR	Q20	
X79	FRONT WINDSCREEN WIPER SWITCH	M24	
X149	REAR AND ROOF WINDSCREEN WIPER SWITCH	K24	
X150	REVOLVING LIGHT SWITCH	G4	
X151	FRONT AND REAR WORKING LIGHT SWITCH	K4	
X152	WORKING LIGHT SWITCH ON BOOM (OPTION)	E24	
X187	WARNING SWITCH	E31	
X188	LIGHT COMMUTATOR SWITCH	A34	
X210	LEFT SIDE WORKING LIGHT	C23	
X211	RIGHT SIDE WORKING LIGHT	C21	

Fuses and relays			
Item	Current	Designation	Position on diagram
F3	10A	HORN + STOP LIGHT	C19
F5	7,5A	LEFT INDICATOR LIGHTS	E37
F6	7,5A	RIGHT SIDELIGHT	E34
F7	7,5A	LEFT SIDELIGHT	E33
F8	7,5A	ROTATING LIGHT	C9
F9	15A	REAR WORKING LIGHTS	C9
F10	15A	FRONT WORKING LIGHTS	C10
F16	10A	WARNING INDICATOR LIGHTS	C17
F17	10A	FRONT WINDSCREEN WIPER	C18
F18	15A	MAIN BEAM HEADLIGHTS	E36
F19	7,5A	RIGHT INDICATOR LIGHTS	E37
F20	15A	DIPPED BEAM HEADLIGHTS	E35
F21	15A	DIGICODE + ROOF LIGHT + WARNING	C7
F22	25A	LIGHT COMMUTATOR SWITCH	C7
F23	15A	REAR WINDSCREEN WIPER + ROOF WINDSCREEN WIPER	C11
F24	15A	HEATING + AIR CONDITIONING	C12
F33	15A	WORKING LIGHTS	C4

Electrical components			
Item	Designation	Position on diagram	Hydraulic code equivalence
K6	FLASHING/WARNING UNIT	C31	
M3	WINDSCREEN WASHER PUMP	Q24	
P06	ROTATING LIGHT	O7	
P07	FRONT LEFT WORKING LIGHTS	Q15	
P08	REAR LEFT WORKING LIGHTS	Q16	
P09	ROOF WINDSCREEN WIPER MOTOR	Q8	
P10	REAR WINDSCREEN WIPER MOTOR	Q10	
P12A	HEATING	O16	
P12B	HEATING	O17	
P14	REAR RIGHT WORKING LIGHTS	Q19	
P15	FRONT RIGHT WORKING LIGHTS	Q18	
P16	CEILING LIGHT	Q13	
S16	BRAKE CIRCUIT PRESSURE SWITCH	O27	

Connectors	Diag. 1	Diag. 2	Diag. 3	Diag. 4	Diag. 5	Diag. 6
X117/B					√	
X118	√	√	√			
X118.S	√	√				
X118P			√			
X118S			√			
X119					√	
X121	√	√	√			
X134					√	
X149				√		
X150				√		
X151				√		
X154				√		
X155				√		
X165		√				
X188				√		
X193	√					
X205						√
X206						√
X208						√
X209						√
X215						√
X221						√
X223						√
X224						√
X224						√
X225						√
X226						√
X227						√
X228						√
X229						√
X232						√
X238		√				
X239						√
X240					√	
X241					√	
X242					√	
X243					√	
X245						√
X246						√
X247						√
X248						√
X249						√
X300		√				
X308	√	√	√	√		√
X310		√				
X311	√	√				
X315			√			
X316			√			
X317	√					
X318	√	√				√
X319		√				
X320		√			√	√

Electrical connectors					
Harness type	Item	Name of component	Designation	Position on diagram	Hydraulic code equivalence
Main	M3	X14	HORN GROUND	G40	
Cab	P09	P09	ROOF WINDSCREEN WIPER MOTOR	Q8	
Cab	P10	P10	REAR WINDSCREEN WIPER MOTOR	Q10	
Cab	P12A	P12A	HEATING	O16	
Cab	P12B	P12B	HEATING	O17	
Main/Electric plate	X04		ELECTRIC PLATE	E7	
Main	X13	X13	FRONT RIGHT HEADLIGHT	Q40	
Main	X14	X14	HORN	G40	
Main	X16	X16	REAR RIGHT HEADLIGHT	Q33	
Main	X17	X17	REAR RIGHT HEADLIGHT	Q28	
Main	X19		REAR TRAILER CONNECTOR	K29	
Main	X20	X20	REVERSING SOUND ALARM (OPTION)	O30	
Main/Cab	X26		MAIN/CAB INTERFACE	M9	
Main	X30	X30	HEATING FAN SWITCH	I24	
Main/Electric plate	X39		ELECTRIC PLATE	G33	
Main/Electric plate	X41		ELECTRIC PLATE	E40 - K31	
Main/Electric plate	X45		ELECTRIC PLATE POWER SUPPLY (KEY SWITCH)	A4	
Main	X70	M3	WINDSCREEN WASHER PUMP	Q23	
Main	X73	S16	BRAKE CIRCUIT PRESSURE SWITCH	O26	
Main	X74	X74	FRONT LEFT HEADLIGHT	Q35	
Main	X77	X77	FRONT WINDSCREEN WIPER MOTOR	Q20	
Main	X79	X79	FRONT WINDSCREEN WIPER SWITCH	M24	
Main	X149	X149	REAR AND ROOF WINDSCREEN WIPER SWITCH	K24	
Main	X150	X150	REVOLVING LIGHT SWITCH	G4	
Main	X151	X151	FRONT AND REAR WORKING LIGHT SWITCH	K4	
Main	X154	V5	DIODE	G30	
	X155	V5	DIODE	G32	
Cab	X188	X188	LIGHT COMMUTATOR SWITCH	C36	
Main/Electric plate	X308		ELECTRIC PLATE	E18	
Main	X329	F33	WORKING LIGHTS FUSE	C4	
Main	X330		WORKING LIGHT ON BOOM (OPTION)	E4	
Main	X336	V7	DIODE	M30	
Main	X337	V7	DIODE	M28	

Electrical components			
Item	Designation	Position on diagram	Hydraulic code equivalence
P16	CEILING LIGHT	Q13	
S16	BRAKE CIRCUIT PRESSURE SWITCH	O27	
V5	DIODE	G31	
V6	DIODE	E34	
V7	DIODE	M29	
X13	FRONT RIGHT HEADLIGHT	Q40	
X14	HORN	G40	
X16	REAR RIGHT HEADLIGHT	Q33	
X17	REAR RIGHT HEADLIGHT	Q28	
X18	REAR LICENSE PLATE LIGHT	O33	
X20	REVERSING SOUND ALARM (OPTION)	O30	
X30	HEATING FAN SWITCH	I24	
X74	FRONT LEFT HEADLIGHT	Q35	
X77	FRONT WINDSCREEN WIPER MOTOR	Q20	
X79	FRONT WINDSCREEN WIPER SWITCH	M24	
X149	REAR AND ROOF WINDSCREEN WIPER SWITCH	K24	
X150	REVOLVING LIGHT SWITCH	G4	
X151	FRONT AND REAR WORKING LIGHT SWITCH	K4	
X152	TELESCOPE WORKING LIGHT SWITCH (OPTION)	E24	
X187	WARNING SWITCH	E30	
X188	LIGHT COMMUTATOR SWITCH	C36	
X210	LEFT SIDE WORKING LIGHT	C23	
X211	RIGHT SIDE WORKING LIGHT	C21	

Fuses and relays			
Item	Current	Designation	Position on diagram
F3	10A	HORN + STOP LIGHT	C19
F5	7,5A	LEFT INDICATOR LIGHTS	E38
F6	7,5A	RIGHT SIDELIGHT	E34
F7	7,5A	LEFT SIDELIGHT	E33
F8	7,5A	ROTATING LIGHT	C9
F9	15A	REAR WORKING LIGHTS	C10
F10	15A	FRONT WORKING LIGHTS	C10
F16	10A	WARNING INDICATOR LIGHTS	C17
F17	10A	FRONT WINDSCREEN WIPER	C18
F18	15A	MAIN BEAM HEADLIGHTS	E36
F19	7,5A	RIGHT INDICATOR LIGHTS	E37
F20	15A	DIPPED BEAM HEADLIGHTS	E35
F21	15A	DIGICODE + ROOF LIGHT + WARNING	C7
F22	25A	LIGHT COMMUTATOR SWITCH	C8
F23	15A	REAR WINDSCREEN WIPER + ROOF WINDSCREEN WIPER	C11
F24	15A	HEATING + AIR CONDITIONING	C12
F33	15A	WORKING LIGHTS	C4

Electrical components			
Item	Designation	Position on diagram	Hydraulic code equivalence
K6	FLASHING/WARNING UNIT	C31	
M3	WINDSCREEN WASHER PUMP	Q24	
P06	ROTATING LIGHT	O7	
P07	FRONT LEFT WORKING LIGHTS	Q15	
P08	REAR LEFT WORKING LIGHTS	Q16	
P09	ROOF WINDSCREEN WIPER MOTOR	Q8	
P10	REAR WINDSCREEN WIPER MOTOR	Q10	
P12A	HEATING	O16	
P12B	HEATING	O17	
P14	REAR RIGHT WORKING LIGHTS	Q19	
P15	FRONT RIGHT WORKING LIGHTS	Q17	

Item	DESIGNATION	Position on harness diagram							Comments
		Harness assembly	Electric plate	Cab	Main	Engine	Distributor	Fan	
X99	STRAIN GAUGE	O9			E4				
X100	BOOM ANGLE SENSOR	M2			C11				
X104	LSU ELECTROVALVE PUMP (OPTION)	K18			G15				
X104/A	LSU PUMP ELECTROVALVE	K18							(Not H)
X109	MODULE RC2-2	K15			G4				(H)
	NOT USED (OPTION)	K15			G4				(Not H)
X109/A	CASAPPA ELECTRONICS CONTROL UNIT	K15							(Not H)
X109/B	CASAPPA ELECTRONICS CONTROL UNIT	K15							(Not H)
X112	PUSH BUTTON + CONTINUE FLOW INDICATOR LAMP	E32			I26				
X113	CONTINUE FLOW POTENTIOMETER	E32			I27				
X114	EMERGENCY STOP	G38			K40				
X115	OBD CONNECTOR DIAGNOSTICS	I15			G22				
X116	EASY CONNECT SYSTEM (ECS) (NF)	I32			E31				
X117	ATTACHMENT LOCKING SWITCH (OPTION)	E38			M2				
X118	DIGICODE CONNECTOR	I25			I22				
X119	OVERRIDE SWITCH	E40			M2				
X121	MAIN/ENGINE INTERFACE	K17			A3	K33			
X134	RETRACTED BOOM SENSOR	M3			C10				
X149	REAR AND ROOF WINDSCREEN WIPER SWITCH	E39			M10				
X150	REVOLVING LIGHT SWITCH	E39			M10				
X151	FRONT AND REAR WORKING LIGHT SWITCH	C39			I9				
X154	DIODE POSITION LIGHT / WORKING LIGHTS	I27			I17				
X165	FUEL LEVEL SENSOR	K23			C37				
X188	LIGHT COMMUTATOR SWITCH	E36	S10						
X193	OPTIONAL CONNECTOR	I27			I16				
X300	HAND BRAKE RELAY	C41			S30				
X301	SNAIL SPEED	A40			I28				(H)
X302	SLOW SPEED	A40			I29				(H)
X303	REVERSE GEAR RELAY	A40			I30				(H)
X304	SLOW SPEED SWITCH	E33			Q14				(H)
X305	FAST / SLOW SPEED SWITCH	E32			Q14				(H)
X306	SLOW SPEED	E32			Q14				(H)
X307	FAST SPEED	E32			S14				(H)
X308	ELECTRIC PLATE	A37	I4		Q40				
X309	ACCELERATOR PEDAL SWITCH	C39			S29				(H)
X310	REVERSE GEAR INFORMATION	A41			I30				(H)
X311	REVERSE GEAR SHUTTLE CONNECTOR	A35	Q8		I21				
X312	SNAIL SPEED ELECTROVALVE	M22			C26				(H)
X313	REVERSE GEAR ELECTROVALVE	M22			C26				(H)
X314	FAST SPEED ELECTROVALVE	M22			C26				(H)
X315	FUSE DIAGNOSTICS	I17			C3				
X316	FUSE DIAGNOSTICS	I17			C3				
X317	INDICATOR LAMP FAULT + SPU	I17			A7				
X318	ELECTRIC PLATE GROUND CONNECTOR	C41	Q13		I37				
X319	BRAKE CIRCUIT CONNECTOR	A38	G6		Q39				
X320	CONNECTOR (OPTION)	A39			S17				
X321	NOT USED (OPTION)	C39			S27				(H)
X322	NEUTRAL SWITCH INFORMATION (OPTION)	C39			S28				(H)
X323	HAND BRAKE SWITCH	E39			K2				
X324	NOT USED (OPTION)	C39			I9				

LONGITUDINAL STABILITY INDICATOR (LLMI)

ERROR CODES

The error codes are indicated by LEDs A3 to A7 on the warning device and longitudinal stability limiter.

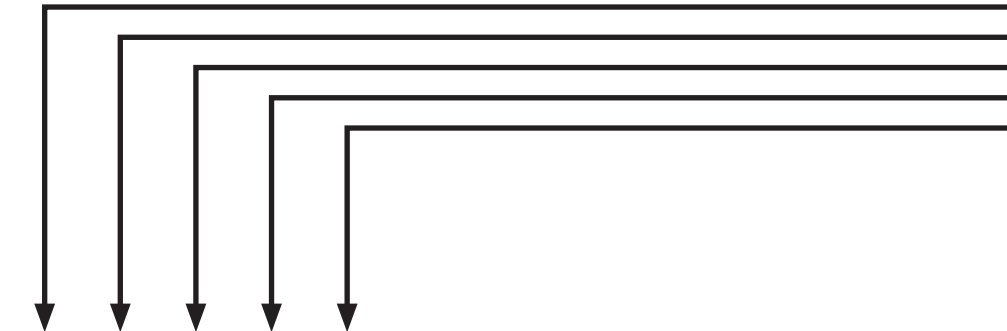
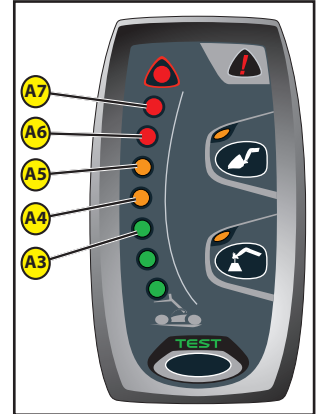

LEDS					ERROR CODES
A7	A6	A5	A4	A3	DESCRIPTIONS
☀	☀	☀	☀	☀	Regulating fault (fault detected during the test).
☀	☀	☀	☀	○	Lowering regulating valve fault.
☀	☀	☀	○	☀	Safety valve cut-off fault (fault detected during the test).
☀	☀	☀	○	○	Safety valve fault.
☀	☀	○	☀	☀	Gauge calibration fault (fault detected during the test). Resetting the longitudinal stability limiter and warning device may resolve the problem. (◀: 3 - MAINTENANCE: G - OCCASIONAL MAINTENANCE)
☀	☀	○	☀	○	Angle calibration fault (fault detected during the test).
☀	☀	○	○	☀	Inclination cut-off valve fault.
☀	○	☀	☀	☀	Strain gauge fault.
☀	○	☀	☀	○	Jib angle sensor fault.
☀	○	☀	○	☀	Telescope or attachment control fault.
☀	○	☀	○	○	Telescope retracted sensor fault.
☀	○	○	☀	☀	Computer earth output fault.
☀	○	○	☀	○	Aggravating hydraulic movement cut-off disable fault.
☀	○	○	○	○	Fan drive valve fault.
○	☀	☀	☀	○	Stability indicator fault.
○	☀	☀	○	☀	Electronic handling controller fault.
○	☀	☀	○	○	Hydraulic control lever control setting fault.
○	☀	○	☀	☀	Transmission cut-off output fault.
○	☀	○	○	☀	Electronic handling controller supply fault.
○	☀	○	○	○	Telescope retracted sensor fault (fault detected during the test).
○	○	☀	☀	☀	Tilt cut-off valve fault (according to model)
○	○	☀	☀	○	Boom head solenoid valve fault. (OPTION)
○	○	☀	○	☀	Button fault, accessory hydraulic easy attachment (OPTION)
○	○	☀	○	○	Electrovalve attachment hydraulic control and electrical jib provision fault button. (OPTION)
○	○	○	☀	☀	Forced operation indicator fault (OPTION)
○	○	○	☀	○	Electric handling controller 10 V output fault.
○	○	○	○	☀	Forced operation button fault (OPTION)

CHARACTERISTICS OF THE ATTACHMENT SCREWS

The bolts used are delivered with the strain gauge.

- Bolt H, M10x30 pitch 1.5 Class 10.9.

PRECAUTIONS FOR ASSEMBLY AND TIGHTENING TORQUE

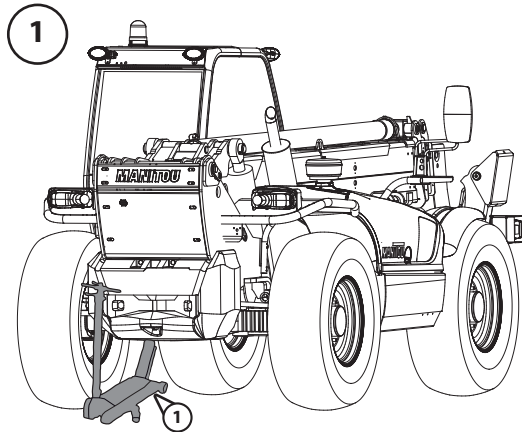

The two components (strain gauge and axle) must be kept at the same temperature for at least 4 hours before commencing assembly.

The strain gauge should be assembled with a completely unloaded axle.

To ensure this:

- 1 - Lift the rear axle from the floor using a hydraulic jack (Item 1) (Part No Manitou 505507).
- 2 - Make the machine safe by placing 2 stands (Item 2) (Part No Manitou 554772) on each side of the chassis.
- 3 - Remove the jack to completely unload the rear axle.

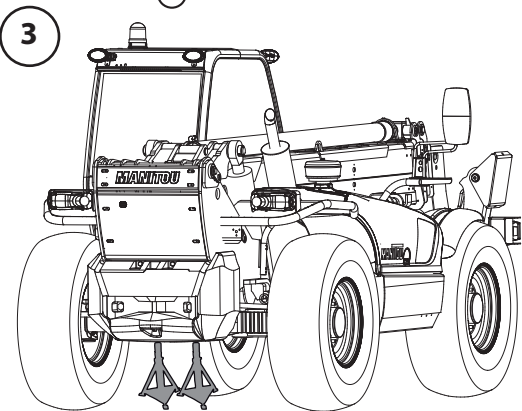
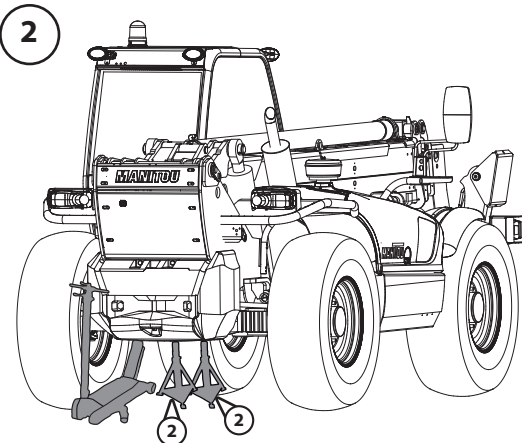

PLD MERCEDES (MR2)		
Fault N°	Fault	Repair instructions
0 25 09	oil level sensor open circuit fault	<ul style="list-style-type: none"> - check oil level sensor B14, replace if necessary. - check wire N3/33 - B14/1 for open circuit fault, repair or replace if necessary. - check wire N3/49 - B14/2 for open circuit fault, repair or replace if necessary - perform functional check
0 25 15	oil level sensor measuring range exceeded	<ul style="list-style-type: none"> - check oil level, correct if necessary. - check wire N3/33 - B14/1 if shortened to battery voltage, repair or replace if necessary. - check oil level sensor B14 resistance, replace if necessary - nominal value: 20-25 Ohm - perform functional check.
0 25 16	oil level sensor remains under measuring range	<ul style="list-style-type: none"> - check oil level, correct if necessary. - check wire N3/33 - B14/1 for ground short, repair or replace if necessary. - check oil level sensor B14 resistance, replace if necessary. nominal value: 20-25 Ohm - perform functional check.
0 25 17	oil level sensor measured value not plausible	<ul style="list-style-type: none"> - check oil level during engine standstill, correct if necessary. - check calibration of oil pan type, correct if necessary. - calibration of oil level sensor, correct if necessary. - check cable, plug, plug connections and electrical components for damage, correct connection, loose contact and corrosion, repair if necessary. - check oil level sensor B14 resistance, replace if necessary. nominal resistance: 22 Ohm when oil pan filled. - perform functional check.
0 40 24	internal fault: auxiliary controller defective	<ul style="list-style-type: none"> - check all affected connectors, plug connections and electrical components for damage, loose contact, corrosion etc. and repair if necessary. - if fault code is still present, renew and program control unit - perform functional check.
0 40 37	internal fault: cylinder number implausible	<ul style="list-style-type: none"> - check all affected connectors, plug connections and electrical components for damage, loose contact, corrosion etc. and repair if necessary. - if fault code is still present, renew and program control unit. - perform functional check.
0 40 38	internal fault: high resistance starter driver (redundant-/auxiliary path)	<ul style="list-style-type: none"> - if fault code 07543 is present, remove this fault code first. - check all affected connectors, plug connections and electrical components for damage, loose contact, corrosion etc. and repair if necessary. - if fault code is still present, renew and program control unit. - perform functional check.
0 40 40	internal fault: level detection starter defective	<ul style="list-style-type: none"> - check all affected connectors, plug connections and electrical components for damage, loose contact, corrosion etc. and repair if necessary. - if fault code is still present, renew and program control unit. - perform functional check.

PLD MERCEDES (MR2)		
Fault N°	Fault	Repair instructions
1 57 26	contact recognition injector-/solenoid valve: no contact cylinder 8	refer to example of fault code 15026...
1 57 27	control failure injector-/solenoid valve: control cylinder 8 disturbed	refer to example of fault code 15027...
1 64 09	heater flange: open circuit fault (heater flange defective)	Condition: The heating flange becomes after Kl. 15 uniquely briefly switched on. Here if no break-down of the battery voltage is recognized, the heating flange is classified as defective. Error threshold and cyclic duration are deposited in the data record.
1 70 06	proportional valve 1: short circuit to ground (-lead)	note: ECU engine control (e.g. MR-PLD) wrong calibration. - check parametrization. - parameter 06 has to be set to NOT ACTIVE - if not, then the data set of ECU engine control (e.g. MR-PLD) is wrong - replace and program ECU engine control (e.g. MR-PLD). - perform functional check.
1 70 07	proportional valve 1: shortened to battery voltage (-lead)	
1 70 09	proportional valve 1: open circuit fault	note: ECU engine control (e.g. MR-PLD) wrong calibration. - check parametrization. - parameter 06 has to be set to NOT ACTIVE - if not, then the data set of ECU engine control (e.g. MR-PLD) is wrong - replace and program ECU engine control (e.g. MR-PLD). - perform functional check.
1 71 06	proportional valve 3: short circuit to ground (-lead)	note: ECU engine control (e.g. MR-PLD) wrong calibration / short circuit to ground - check calibration, correct if necessary. Parameter 008 has to be set to NOT ACTIVE. - if the calibration is OK, check wire N3/41 - Y70/1 for short circuit to ground, repair or replace if necessary. - if still no fault can be detected, replace and program ECU engine control (e.g. MR-PLD). - perform functional check.
1 71 07	proportional valve 3: shortened to battery voltage (-lead)	

CLICK HERE TO **DOWNLOAD** THE COMPLETE MANUAL

- Thank you very much for reading the preview of the manual.
- You can download the complete manual from: www.heydownloads.com by clicking the link below



- Please note: If there is no response to CLICKING the link, please download this PDF first and then click on it.

CLICK HERE TO **DOWNLOAD** THE COMPLETE MANUAL