



**GENUINE PARTS CATALOGUE  
CATALOGUE PIÈCES D'ORIGINE  
ORIGINAL ERSATZTEILKATALOG  
CATALOGO DE PIEZAS LEGITIMAS  
CATALOGO RICAMBI ORIGINALI**

This document has been printed from 

### **MANITOU BF**

Head office: 430, Rue de l'Aubinière  
44150 Ancenis - FRANCE  
Share capital: 39,548,949 euros  
857 802 508 RCS Nantes  
Tel: +33 (0)2 40 09 10 11  
[www.manitou.com](http://www.manitou.com)

CLICK HERE TO **DOWNLOAD** THE COMPLETE MANUAL

- Thank you very much for reading the preview of the manual.
- You can download the complete manual from: [www.heydownloads.com](http://www.heydownloads.com) by clicking the link below



- Please note: If there is no response to CLICKING the link, please download this PDF first and then click on it.

CLICK HERE TO **DOWNLOAD** THE COMPLETE MANUAL

<b>FMI</b>	<p>Failure Mode Identifier: identifies the type of fault:</p> <ul style="list-style-type: none"> <li>0 – The data is valid but the data is above the normal operational range.</li> <li>1 – The data is valid but the data is below the normal operational range.</li> <li>2 – The data is erratic, intermittent, or incorrect.</li> <li>3 – The voltage is above normal or the voltage is shorted high.</li> <li>4 – The voltage is below normal or the voltage is shorted low.</li> <li>5 – The current is below normal or the circuit is open.</li> <li>6 – The current is above normal or the circuit is grounded.</li> <li>7 – The mechanical system is not responding properly.</li> <li>8 – There is an abnormal frequency, an abnormal pulse width, or an abnormal time period.</li> <li>9 – There has been an abnormal update.</li> <li>10 – There is an abnormal rate of change.</li> <li>11 – The failure mode is not identifiable.</li> <li>12 – The device or the component is damaged.</li> <li>13 – The device requires calibration.</li> <li>14 – There is a special instruction for the device.</li> <li>15 – The signal from the device is high (least severe).</li> <li>16 – The signal from the device is high (moderate severity).</li> <li>17 – The signal from the device is low (least severe).</li> <li>18 – The signal from the device is low (moderate severity).</li> <li>19 – There is an error in the data from the device.</li> <li>20 – There is an error in the data from the device (high).</li> <li>21 – There is an error in the data from the device (low).</li> <li>31 – The device has failed and the engine has shut down.</li> </ul>
<b>gr.</b>	Greek: signifies a word of Greek origin.
<b>h</b>	hours: unit of measurement for time derived from the second (1 h = 3600 s).
<b>HC</b>	Hydrocarbon: organic compound consisting exclusively of carbon (C) and hydrogen (H) atoms.
<b>Hz</b>	Hertz: One hertz is equivalent to one event per second ( $s^{-1}$ or 1/s).
<b>HS</b>	High Side: power side power supply.
<b>HVAC</b>	Heating, Ventilation and Air-Conditioning: in-cab heating, ventilation and air-conditioning block.
<b>HMI</b>	Human-Machine Interface: dashboard screens.
<b>i.V.</b>	Interactive View: 2 <sup>nd</sup> generation MANITOU machine diagnostics software.
<b>JSM</b>	Joystick Switch & Move: joystick serving to perform all telescope movements, as well as to control machine forward and reverse movements with one hand.
<b>lat.</b>	Latin: signifies a word of Latin origin.
<b>LIN</b>	Local Interconnect Network.
<b>LLMI</b>	Limit Load Moment Indicator: strain gauge ensuring machine stability.

## MI 50L-60-70D\_ST3B-S2 &amp; US

MI 50L-60-70D_ST3B-S2 & US						
Performance parameters	5.1	Speed of travel laden (1st/2nd)	mph (km/h)	3.7 / 7.4 / 11.2 (6 / 12 / 18)	3.7 / 7.4 / 11.2 (6 / 12 / 18)	3.7 / 7.4 / 11.2 (6 / 12 / 18)
	5.1.1	Speed of travel unladen (1st/2nd)	mph (km/h)	3.7 / 7.4 / 14.9 (6 / 12 / 24)	3.7 / 7.4 / 14.9 (6 / 12 / 24)	3.7 / 7.4 / 14.9 (6 / 12 / 24)
	5.2	Speed of rise laden	ft/min (m/s)	74.8 (0.38)	70.9 (0.36)	70.9 (0.36)
	5.2.1	Speed of rise unladen	ft/min (m/s)	90.6 (0.46)	90.6 (0.46)	80.7 (0.41)
	5.3	Speed of lowering laden	ft/min (m/s)	94.5 (0.48)	94.5 (0.48)	94.5 (0.48)
	5.3.1	Speed of lowering unladen	ft/min (m/s)	82.7 (0.42)	82.7 (0.42)	82.7 (0.42)
	5.5	Nominal towing power laden	lbf (N)	14118 (62800)	14118 (62800)	14118 (62800)
	5.5.1	Nominal towing power unladen	lbf (N)	8093 (36000)	8093 (36000)	8093 (36000)
	5.7	Slope laden	%	43	39	34
	5.7.1	Slope unladen	%	-	-	-
	5.9	Acceleration time laden	s	4.6	4.6	4.6
5.9.1	Acceleration time unladen	s	-	-	-	
5.10	Service brake		Hydraulics	Hydraulics	Hydraulics	
Engine specification	7.1	Engine manufacturer / Type		Deutz TCD3.6 + DOC	Deutz TCD3.6 + DOC	Deutz TCD3.6 + DOC
	7.2	Useful power	hp (KW)	74 (55.4)	74 (55.4)	74 (55.4)
	7.3	Rated speed	rpm	2200	2200	2200
	7.4	Number of pistons/Capacity	cu.in. (cm3)	4 / 220 (3,600)	4 / 220 (3,600)	4 / 220 (3,600)
	7.5	Fuel consumption according to VDI cycle	gph (L/h)	2.48 (9.4)	2.48 (9.4)	2.48 (9.4)
Miscellaneous	8.2	Working hydraulic pressure for attachments	Psi (Bar)	2828 (195)	2828 (195)	2828 (195)
	8.3	Oil flow rate for attachments	gpm (L / min)	14.5 (55)	14.5 (55)	14.5 (55)
	8.4	Sound level at driver's ears according to DIN 12053	dB (A)	84	84	84
	8.5	Towing hook / DIN type		-	-	-
		Average weighted acceleration on driver's body (according to NF EN 13059)	m/s <sup>2</sup>	1.2	1.2	1.2
		Battery	V/Ah	2 x 12 / 90Ah	2 x 12 / 90Ah	2 x 12 / 90Ah
		Diesel tank capacity	g (L)	29 (110)	29 (110)	29 (110)
		Transmission manufacturer		ZF	ZF	ZF
		Type		Powershift	Powershift	Powershift
	Number of speeds (F/R)		3 / 3	3 / 3	3 / 3	

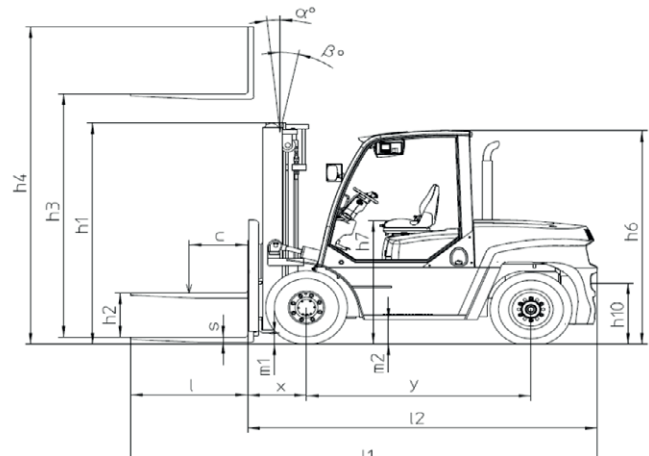
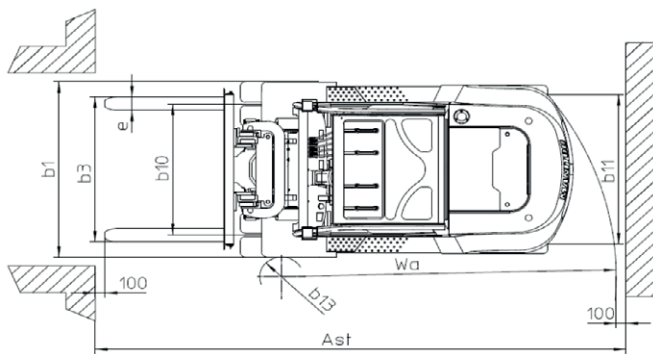

## 00.5.2 METRIC - IMPERIAL UNIT CONVERSION

### CONVERSION COEFFICIENTS:

<b>Metric Unit (S.I)</b>	<b>Coefficient</b>	<b>Imperial Unit US</b>
°C (Celsius degree)	x 1.8 + 32	= °F (Fahrenheit degree)
cm <sup>3</sup> (centimeter cube)	x 0.06102	= cu.in. (cubic inches)
cv (cheval vapeur)	x 0.9859	= hp (horsepower)
bar (bar)	x 14.51	= psi (pound-force/square inch)
g (gram)	x 0.0353	= oz av (ounce avoirdupois) (oz : lat. onza)
kg (kilogram)	x 2.2046	= lb (pound) (lat . libra)
km/h (kilometer per hour)	x 0.6214	= mph (miles per hour)
kW (kilowatt)	x 1.34048	= hp (horsepower)
ℓ (liter)	x 0.2642	= gal US (US gallon)
ℓ (liter)	x 1.0567	= qt US (quart US gallon)
m (meter)	x 3.2808	= ft (foot)
m (meter)	x 39.37	= in (inch)
mℓ (milliliter)	x 0.0338	= fl oz (fluid ounce) (fl : fluid, oz : lat. onza)
mm (millimeter)	x 0.03937	= in (inch)
μm (micrometer)	x 0.03937	= mil (thousands of an inch)
N (Newton)	x 0.2248	= lbf (pound-force) (lb : lat. libra, f : force)
N.m (Newton meter)	x 0.7376	= ft-lb (pound-force-foot) (ft : foot, lb : lat. libra)
rad/s (radian/second)	x 9.5493	= rpm (revolution per minute)
t (metric ton)	x 2204.62	= lb (pound) (lat. libra)
tr/min (tour per minute)	x 1	= rpm (revolution per minute)

### OTHER UNIT CONVERSIONS:

<b>Unit</b>	<b>Coefficient</b>	<b>Unit</b>
in (inch) (pouce)	x 12	= ft (foot)
oz av (once avoirdupois)	x 16	= lb (pound) (lat. libra)
mm (millimeter)	x 1000	= m (meter)
μm (micrometer)	x 1000	= mm (millimeter)
kg (kilogram)	x 1000	= t (metric ton)
° (angle degree)	x 57.2958	= rad (radian)



Strap the radiator (1).



Remove the side fastening screws (1).

Remove the radiator.

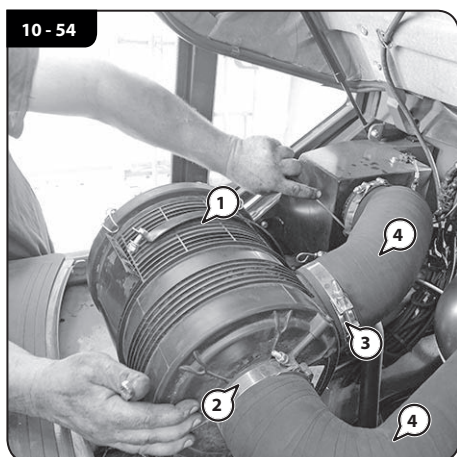
**10.4.2 REMOVE THE AIR FILTER.**

- Open the driver's seat cover.
- Undo the retaining collars (1).
- Undo the outlet hose clamps (2).
- Undo the inlet hose clamps (3).
- Pull out the hoses (4).

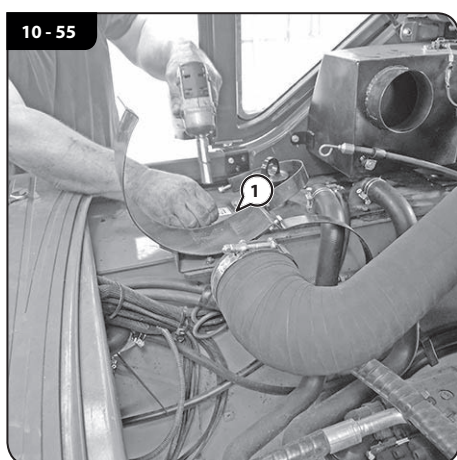

- Remove the air filter.
- Remove the lower support if required (1).

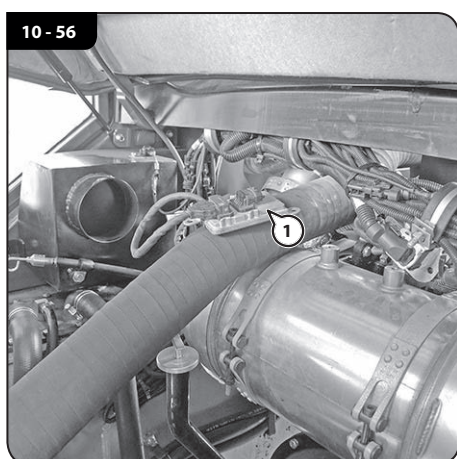
**10.4.3 REMOVE THE CATALYTIC CONVERTER.**

- Remove the air filter. (◀ **10.4.2 REMOVE THE AIR FILTER.**, 46)
- Disconnect the lambda sensor (1).

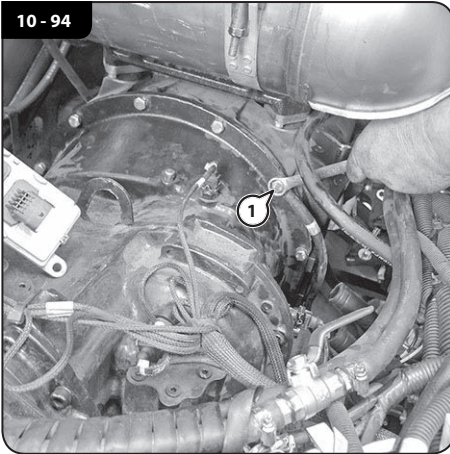

Ground wire (1).

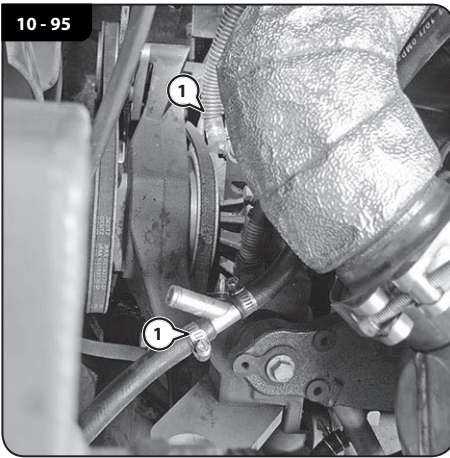

Heating hoses (1).

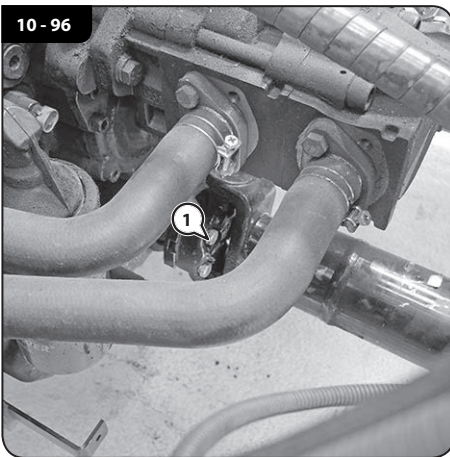

Disassemble the front universal joint (1).

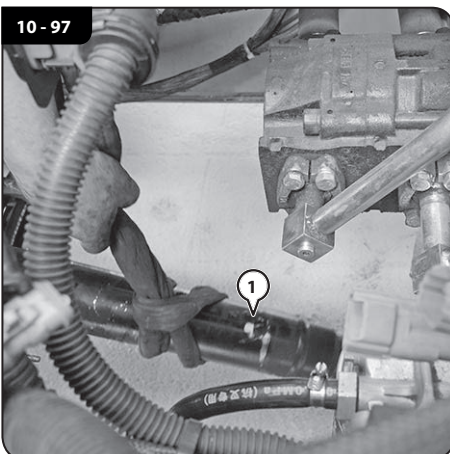

Remove the front universal joint (1).

No.	Designation	No.	Designation	No.	Designation
1	Turbine shaft	11	Internal friction plate	21	Low speed
2	Elastic connector plate	12	External friction plate	22	Connection flange
3	Turbine	13	Circular plate	23	Parking brake sprocket
4	Guide wheel	14	Buffer	24	Parking brake shaft
5	Pump wheel	15	Shaft assembly F	25	Internal expansion mechanical parking brake
6	Bearing shaft	16	Forward gear I	26	High speed
7	Tensioner	17	Reverse gear	27	Output shaft
8	Pump drive gear	18	Reverse gear I	28	Reverse gear II
9	Oil pump assembly	19	Reverse gear	-	-
10	Forward gear II	20	Shaft assembly R	-	-

When forward gear 1 is engaged, the forward 1 clutch is activated and the forward 2, reverse 1 and reverse 2 clutches are at rest, according to the following sequence: part 1 → part 15 → part 16 → part 21 → part 27 → part 22.

When forward gear 2 is engaged, the forward 2 clutch is activated and the forward 1, reverse 1 and reverse 2 clutches are at rest, according to the following sequence: part 1 → part 15 → part 10 → part 26 → part 27 → part 22.

When reverse gear 1 is engaged, the reverse 1 clutch is activated and the forward 1, forward 2 and reverse 2 clutches are at rest, according to the following sequence: part 1 → part 15 → part 17 → part 19 → part 20 → part 18 → part 21 → part 27 → part 22.

When reverse gear 2 is engaged, the reverse 2 clutch is activated and the forward 1, forward 2 and reverse 1 clutches are at rest, according to the following sequence: part 1 → part 15 → part 17 → part 19 → part 20 → part 28 → part 26 → part 27 → part 22.

The forward and reverse clutches are controlled by the control valve assembly. The internal gear pump constitutes the oil pump assembly, the oil pump supplies the pressurised oil system. Once used by the torque converter, the oil is introduced into the vehicle's radiator, then on the friction plate, the bearings and the gearbox pinions.

The gearbox has a parking brake.

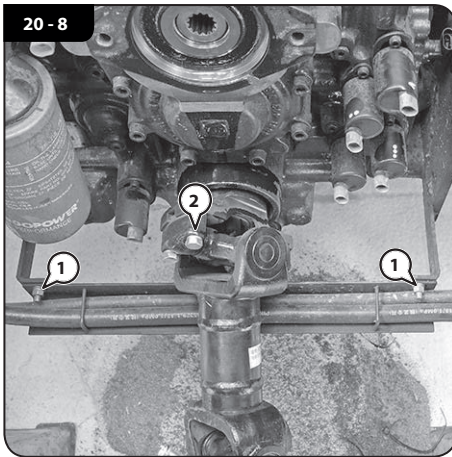

Remove the mast hose support (1).  
Remove the universal joint (2).

Remove the driver's seat cover. (◀ **90.1.2 REMOVE THE DRIVER'S SEAT COVER.**, ☞ 244)

Remove the hydraulic pump. (◀ **REMOVE THE HYDRAULIC PUMP.**, ☞ 41)

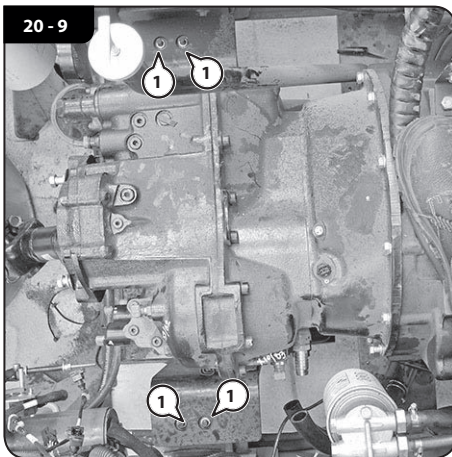

Loosen the gearbox supports (1).

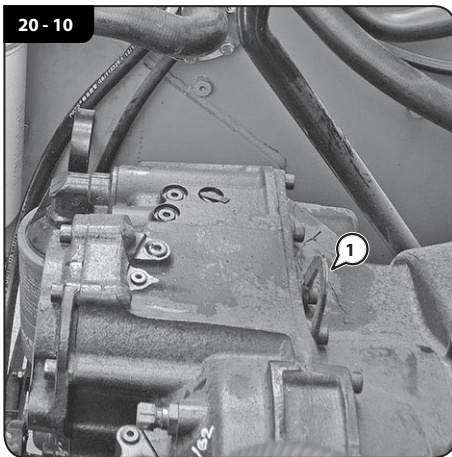

Sling the gearbox on the hook (1).

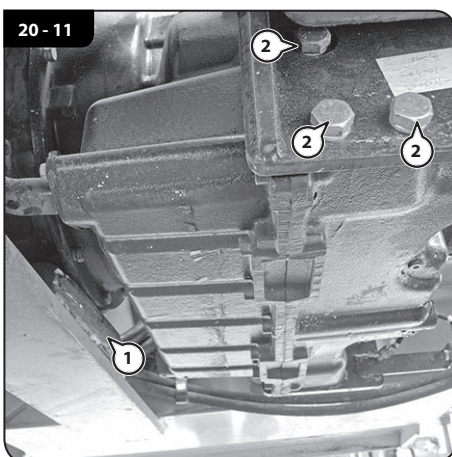

Wedge under the engine (1).  
Remove the 3 screws either side of the gearbox (2).

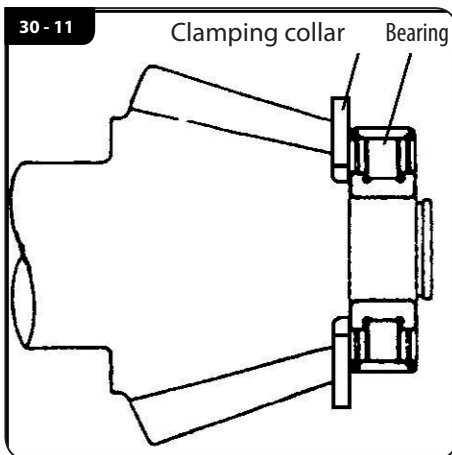

**DISASSEMBLING THE HELICAL DRIVE GEAR**

Using a bearing extractor, remove the bearings and the snap rings on the helical drive gear.

Remove the bearing cages and the screws on the caps.

Remove the lock nuts from the flange yoke, the washers, the flange yoke, the cap, the oil seal and the spacer rings.

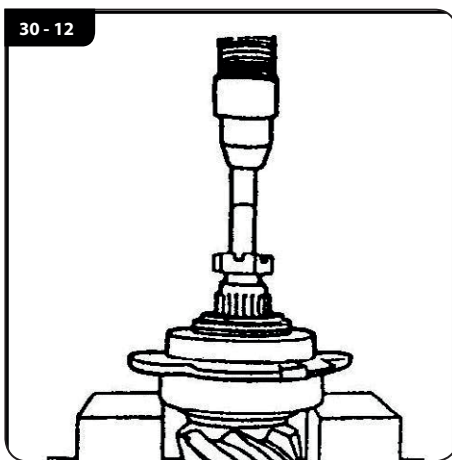

Apply pressure to the helical drive gear and pull the bearing cages.

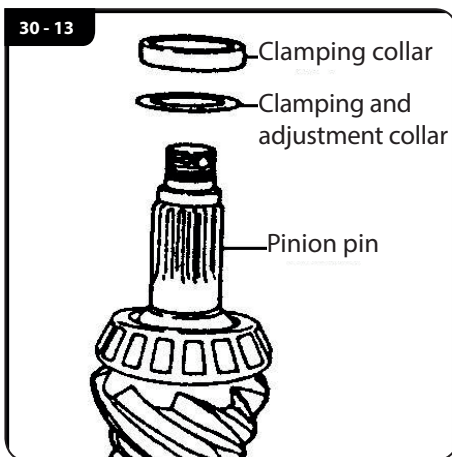

Remove the adjusting spacer and the spacer from the helical drive gear.

Remove the taper bearings with a bearing extractor.

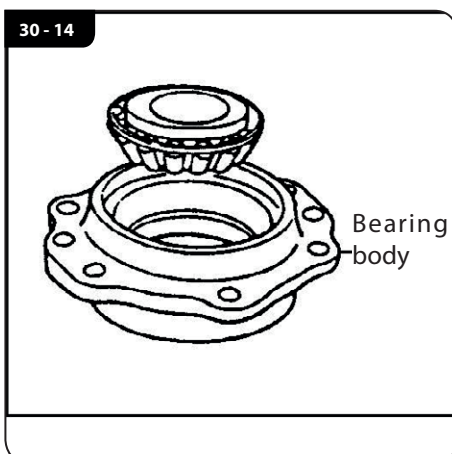

Remove the taper bearings on the bearing cages.

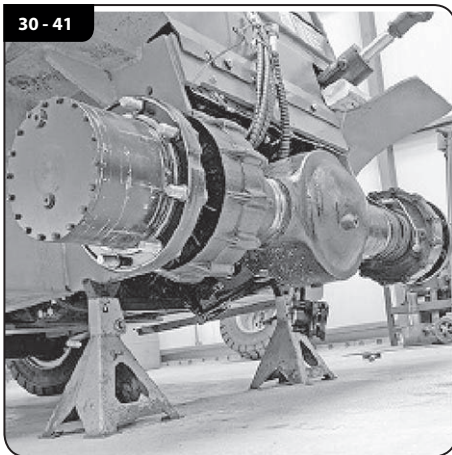

Axle released.

### **REMOVE THE FRONT AXLE**

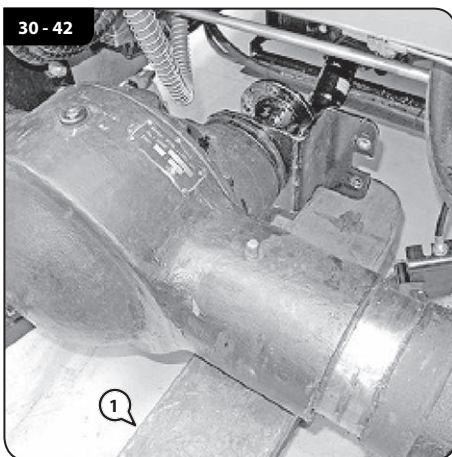

Place a pallet truck under the axle (1).

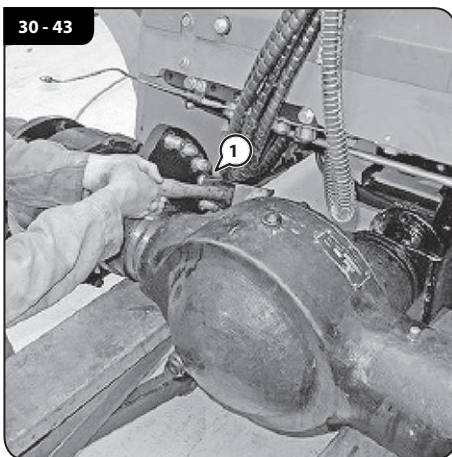

Remove the retaining nuts and take out the pins (1).

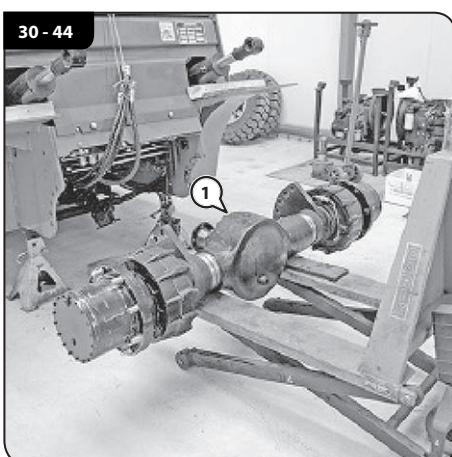

Remove the axle (1).

## 40.1.5 OIL-IMMERSED DISC BRAKE SYSTEM (8T - 10T) - DIAGRAM 1

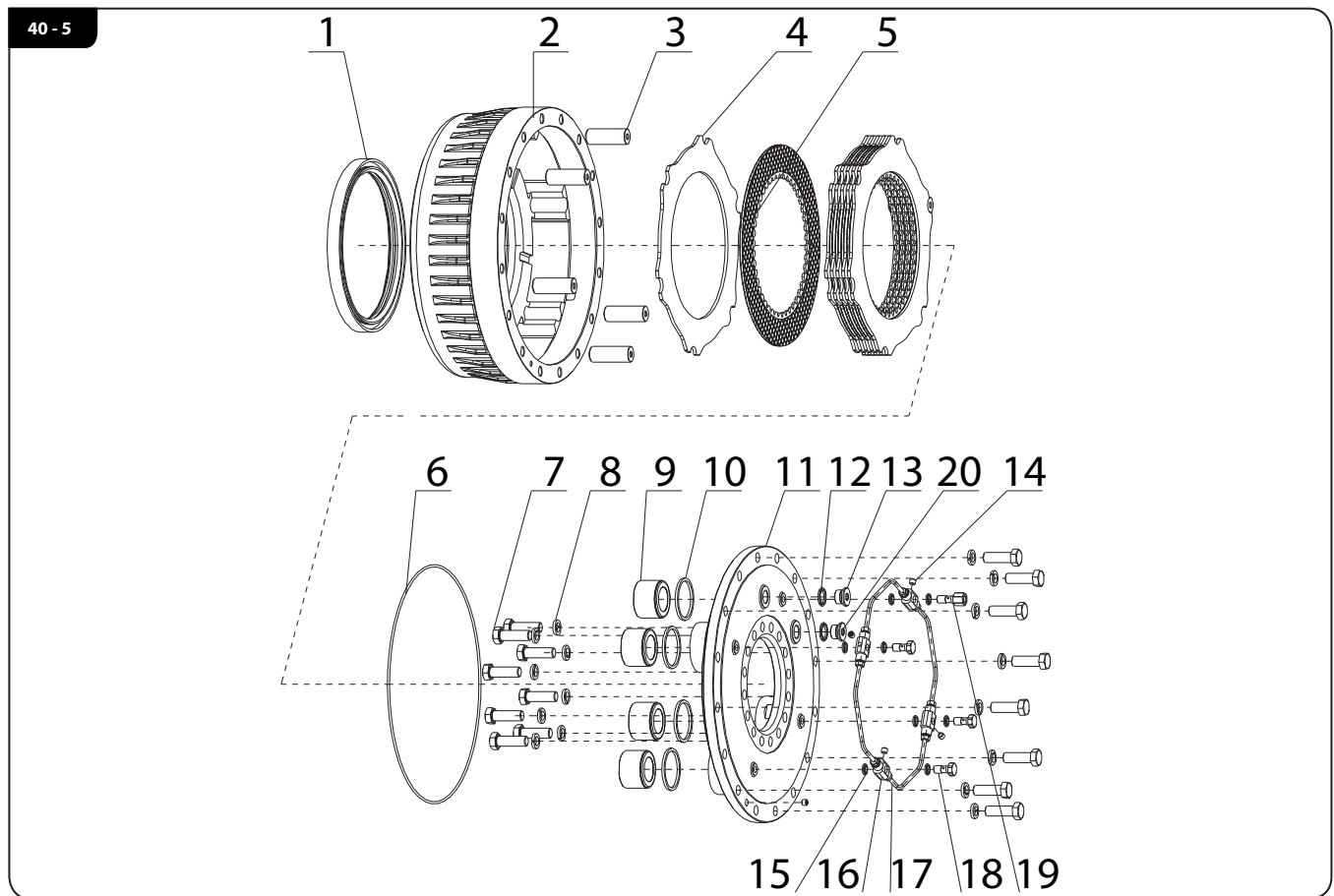

- 1 - Lip seal
- 2 - Brake housing
- 3 - Needle bearing
- 4 - Brake disc
- 5 - Friction disc
- 6 - O-ring seal
- 7 - Screw

- 8 - Washer
- 9 - Piston
- 10 - Seal
- 11 - Cylinder body
- 12 - Washer
- 13 - Filler plug
- 14 - Bleed screw

- 15 - Washer
- 16 - Connector
- 17 - Brake fluid hoses.
- 18 - Screw
- 19 - Screw
- 20 - Level plug

## 60.3 CHECKING AND ADJUSTMENT OF MASTS

### 60.3.1 MAST DISASSEMBLY

#### LIFTING CYLINDER DISASSEMBLY

Place the masts flat on the ground.

Undo the bolts on the lowering cylinder piston rod.

Undo the U bolts and the clamping screws on the outer mast.

Slide the inner mast.

Remove the lifting and lowering cylinder.

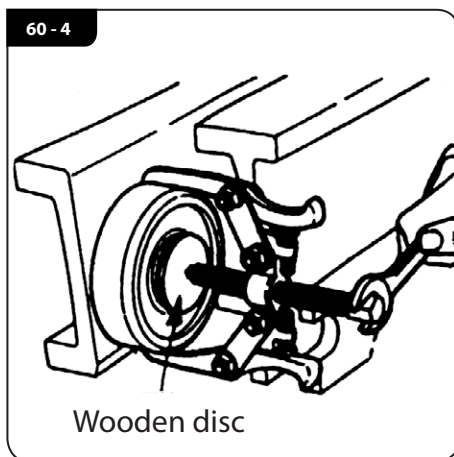

#### ROLLER DISASSEMBLY

Pull the inner mast downwards.

Make two discs of wood approximately 10 mm (0.394 in) thick and with a diameter large enough to cover the seat of the roller.

Pull the primary roller and the side rollers.

If there is no extractor, make sure not to break the roller when you disassemble it (tap symmetrically left and right, top and bottom).

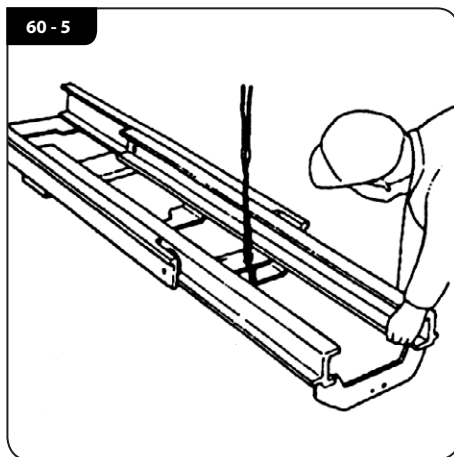

#### OUTER MAST REMOVAL

Unroll a steel cable in the middle of the inner mast. Using a lifting device, slide it upwards.

#### CHECKING

Inspect the rollers, roller seats and the other parts involved. Replace the damaged parts.

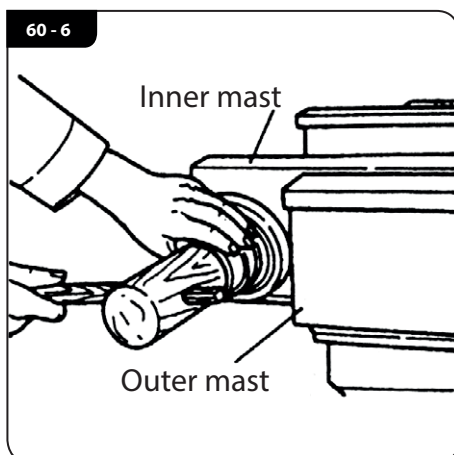

### 60.3.2 MAST ASSEMBLY AND ADJUSTMENT

#### ROLLER ASSEMBLY

Slide the inner mast into the outer mast and fit the rollers.

## 60.4 REMOVAL - REFITTING ON MAST 50L - 60 - 70 D

### 60.4.1 REMOVE THE FORKS.

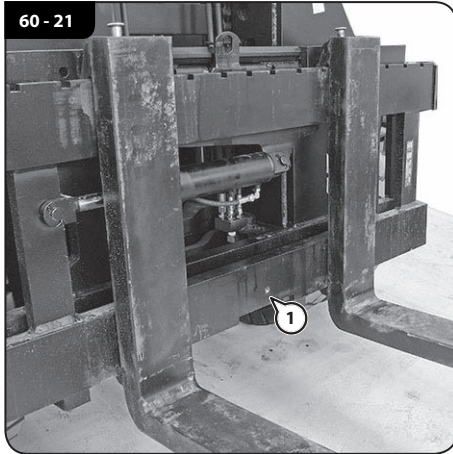

Raise the carriage.  
Remove the fork stop screw (1).

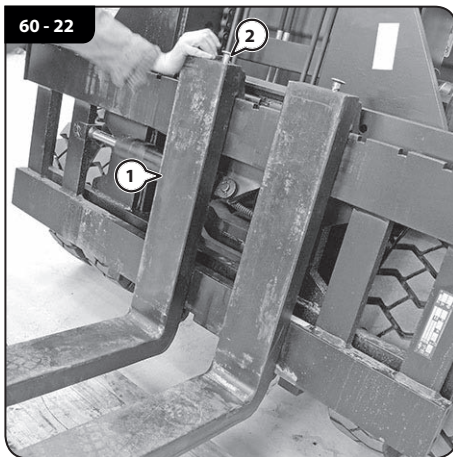

Slide the fork (1) towards the centre of the carriage by lifting the studs (2).

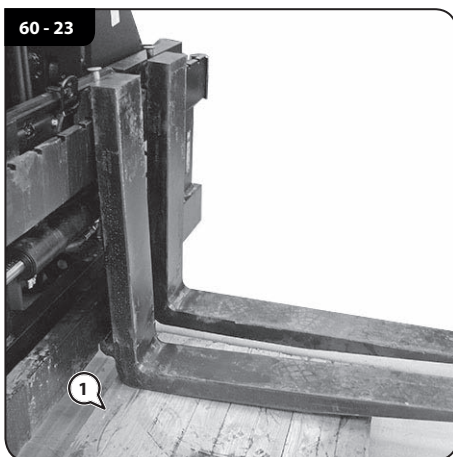

Wedge under the fork (1) to lift it up and remove it.

Repeat the operation for the other fork.

### 70.1.8 ONE-WAY FLOW CONTROL VALVE

The one-way flow control valve is installed on the forklift truck's lifting return circuit. It is situated in front of the lifting cylinder oil inlet. It is a one-way throttle valve.

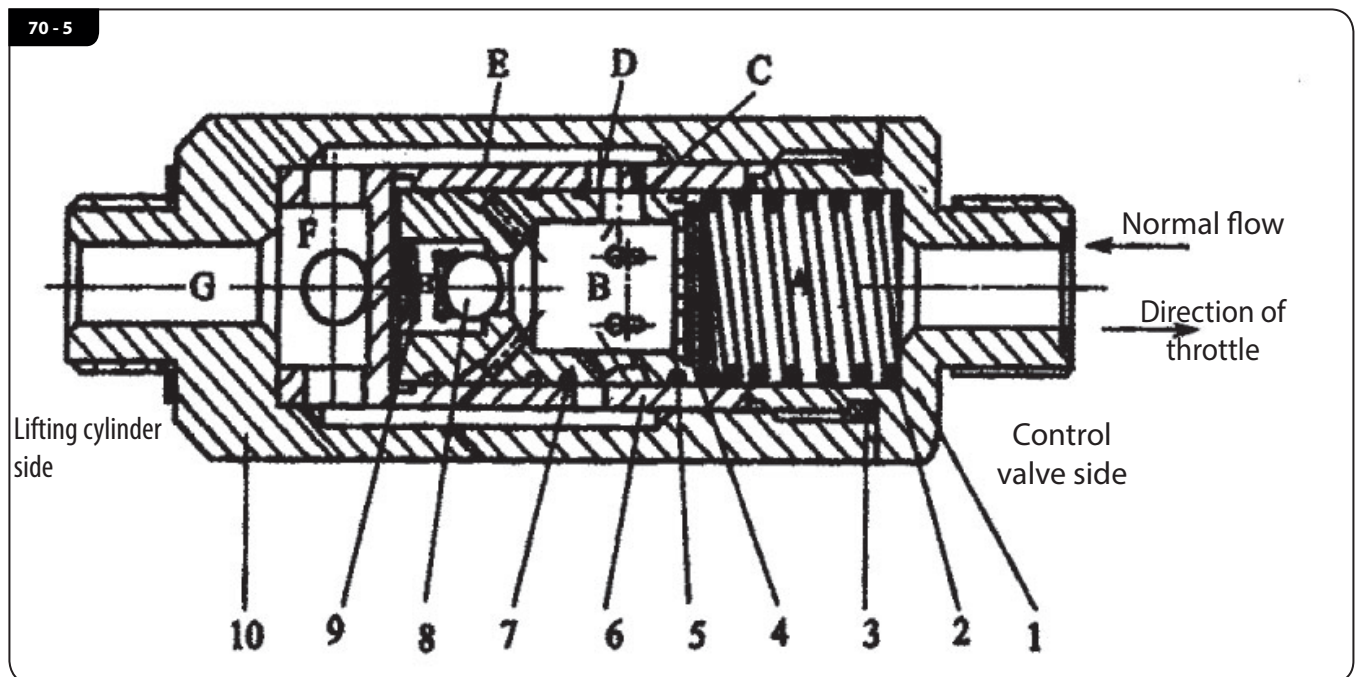

- 1 - Flow control valve
- 2 - Valve chamber

- 3 - Spring
- 4 - Locator nut

This valve opens fully when the cylinder is lifted. The whole flow rate passes through it quickly. When the cylinder is lowered, the holes A and B for the oil to travel from the valve obstruct some of it. This creates a throttle effect and the oil flow rate decreases. The fork lowering speed decreases

<b>Fault</b>	<b>Cause</b>	<b>Solutions</b>
<b>The tilting cylinders are not synchronised</b>		Adjust the tilting cylinder piston so that the threading at the end goes further into the observation port on the ring. Secure the connection by adjusting the piston rod. The movements of the two cylinders must be synchronised.
	There is air in the system	Bleed using the bleed valve
	The gear pump bearings are worn	Replace the bearings
	The gear pump side plate is damaged	Replace the side plate

#### 70.4.2 TROUBLESHOOTING (CONTROL VALVE)

<b>Fault</b>	<b>Cause</b>	<b>Solutions</b>
<b>The pressure in the safety valve is unstable or does not increase</b>	The pressure adjusting screws are loose	Readjust the pressure and block
	The adjustment spring is deformed or damaged	Replace
	The safety valve core is damaged or broken	Replace or disassemble, rinse and refit
	The pump is not working	Repair the pump
<b>Start the engine, move the lever forwards and backwards, tilt the mast forwards</b>	The tilt blocking valve is damaged or worn	Replace the valve core assembly and the tilt blocking valve
	The tilt blocking spring is broken	Replace the spring
	The tilt blocking valve O-ring is damaged	Replace the O-ring
<b>Instability when tilting mast forwards</b>	The tilt pressure reducing valve is not working	Replace the tilt pressure reducing valve assembly
<b>When putting the lever in neutral, the fork carriage moves down</b>	The valve body and the valve rod are abraded and the gap is too large	Replace with a valve rod with the specified gap
	The position of the valve rod is not centred	Position the valve rod in the centre
	The cylinder seal is not good	Repair the cylinder
	The overload valve is abraded or foreign material has got in	Replace or clean the overload valve

**CHECKING THE LIGHT SWITCH**

Disconnect the wires and measure the contacts of the circuit.  
Using a multimeter (set to ohm), check the light lever's positions.

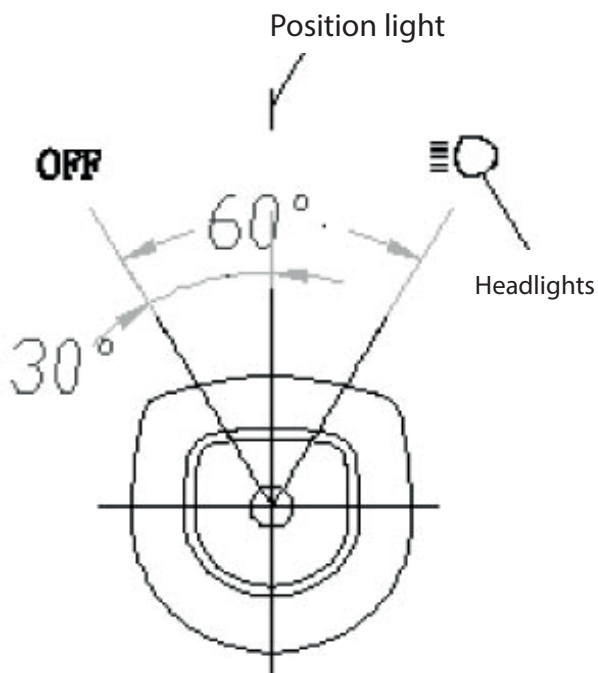

Position	PIN No. contact
Headlights	4-6
Sidelights	4-5
OFF	No malfunction

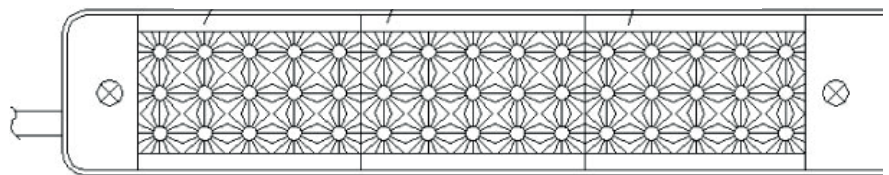
**80.1.5 HEADLIGHTS AND TAIL LIGHTS****Bulb specifications**

Lights	Specifications
Headlamp cluster	
Headlights	24V-70W
Direction indicator lights	24V-21W
Sidelights	24V-5W
(LED) tail light cluster	
Direction indicator lights	(3.2V-20mA)×15
Stop lights, sidelights	(3.2V-20mA)×15
Reversing lights	(3.2V-20mA)×15

COMPONENTS		
Item	Designation	Position on diagram
E02	Sensing control box	E5
E06		B13
FT		A5
G1	12V 90Ah maintenance battery	A2
G2	24V 60A alternator	A7
H01	Horn	I3
H02	12V alarm reversal	F9
H03	Alarm	G9
H1_1	Front left position light	J9
H1_2	Front left indicator light	G9
H2_1	Front right lamp	J9
H2_2	Front right indicator light	G9
H3	35W front lamp	J9
H4	35W front lamp	J9
H5_1	Rear right sidelight	J9
H5_2	Rear right indicator light	G9
H5_3	Right brake light	H9
H5_4	Right hand reverse light	F9
H6_1	Rear left position light	J9
H6_2	Rear left indicator light	G9
H6_3	Left brake light	G9
H6_4	Left hand reverse light	F9
H7	Hazard warning light indicator	E6
H11	Oil pressure indicator lamp	D6
H12	12V alarm	C6, D6
H14	Fault alarm indicator	C6, E6
H16	Parking brake indicator lamp	E6
M1	Starter	B9
M5	Rear windscreen wiper motor	I5
M6	Rear windscreen washer motor	I6
M7	Fan engine	I9
M8	Windscreen wiper motor	I7
M9	Windscreen washer motor	I8
P1	12V water temperature gauge	D6
P2	12V oil gauge	D6
P3	24V timer	D6
QK		C2
S1	Lighting switch	J5
S2	Horn button	I5
S3	Brake light switch	G5
S4	Warning switch	G5
S5	Indicator light switch	G5
S6	Circuit breaker	A1
S8	Seat switch	F2
S9	Handbrake switch	F2, D9
S10		C11
S102	Oil temperature indicator	D8
S103	Water temperature sensor	D8
S104	Oil level sensor	D8
S106	Accumulator pressure switch	F2
F1		F2
F2		E2
R1		F2
R2		E2
T	Accelerator pedal	C14
V1	2A / 600V diode	E4
V2	2A / 600V diode	E4
V3	2A / 600V diode	E3
V4	2A / 600V diode	E3
Y1	Forward electrovalve	E9
Y2	High speed electrovalve	E9

COMPONENTS		
Item	Designation	Position on diagram
Y3	Reversal valve	E9
Y4	Mast lifting electrovalve	F9
Y5	Mast tilting electrovalve	F9

## 80.2.5 MI 50L-60-70 G\_DUALFUEL

## PARTS LIST

FUSES AND RELAYS			
Item	Power	Designation	Position on diagram
F1		55A fuse	B1
F2		55A fuse	C1
F3	15A	Fuse	J2
F4	10A	Fuse	I2
F5	10A	Fuse	G2
F6	10A	Fuse	G2
F7	15A	Fuse	E2
F8	10A	Fuse	D2
F9	10A	Fuse	D2
F13	10A		H2
F14	20A		I2
K1		12V starter relay	B5
K3		12V light relay	J5
K5		12V neutral relay	E6
K6		12V shuttle relay	E7
K7		12V neutral relay	F7
K8		12V high-to-low speed change relay	E8
K9		Basing lifting mast 12V relay	F8
K10		12V indicator light	G5
K13			H6

Controller EO2		
Input output	Colour	Designation
1	black	A1/ACC
1	grey	B+
2	black	Hand brake alarm
4	grey	Shuttle
4	black	Mast raise - lower
5	grey	high-to-low speed transfer
5	black	high speed electrovalve
6	grey	Accumulator
6	black	shuttle electrovalve
7	grey	handbrake switch
7	black	forward electrovalve
8	grey	Seat
8	black	Starter
9	grey	forward switch
9	black	Alarm
10	grey	
12	black	B-

Engine connector (EO6)	
Input output	Designation
1A	Acc
3C	
3C"	Charge indicator
4D	
5E	Oil pressure indicator
6F	Starter relay signal
7G	Fault indicator
9J	accelerator pedal signal
10K	accelerator pedal signal
11L	Accelerator pedal ground
12H	Accelerator pedal switch
15R	Accelerator pedal ground
16S	Accelerator pedal switch



Unscrew the electric cable attachment (1).

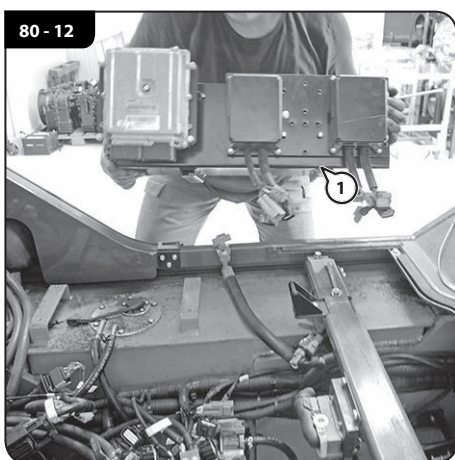

Remove the ECU assembly (1).

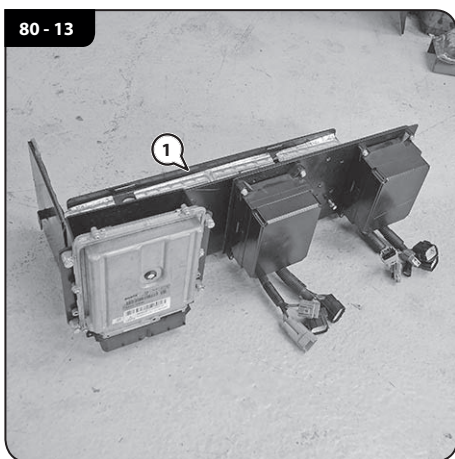

DTC Engine Control Unit EDC17CV52					
Hexadecimal		Decimal		KWP Code	Description
SPN	FMI	SPN	FMI		
012A1	02	4769	2	1403	"Sensor exhaust gas temperature OxiCat downstream (regeneration); plausibility error"
012A1	03	4769	3	1034	"Sensor error exhaust gas temperature downstream (DOC); signal range check high"
012A1	04	4769	4	1035	"Sensor error exhaust gas temperature downstream (DOC); signal range check low"
7F149	05	520521	5	1015	"Actuator error EGR-Valve (2.9;3.6) or Throttle-Valve (4.1;6.1;7.8); signal range check low."
7FB00	01	523008	1	648	Manipulation control was triggered
7FB00	02	523008	2	649	Timeout error in Manipulation control
7FB01	09	523009	9	825	The pressure relief valve (PRV) has reached the number of allowed activations.
7FB01	0A	523009	10	833	Open time of Pressure Relief Valve (PRV) for wear out monitoring had exceeded
7FB52	02	523090	2	362	Engine brake Pre-Selection switch. Plausibility error.
7FBCB	09	523211	9	164	Timeout error of CAN-Receive-Frame EBC1.
7FBCC	09	523212	9	171	Timeout error of CAN-Receive-Frame ComEngPrt. Engine Protection.
7FBCE	0C	523213	12	174	Timeout error of CAN-Transmit-Frame ERC1.
7FBD0	09	523216	9	198	Timeout error of CAN-Receive-Frame PrHtEnCmd. Pre-heat command, engine command.
7FBE8	09	523240	9	179	Timeout CAN-message FunModCtl. Function Mode Control.
7FC42	0E	523330	14	919	Immobilizer status; fuel blocked
7FC42	0E	523330	14	920	"DFC to block the fuel by Sia No detail informationen!"
7FC42	0E	523330	14	921	"DFC to indicate that TEN-code or UC-code received if ECU is learned. No detail informationen!"
7FC42	0E	523330	14	922	DFC to indicate that no code is received via CAN. No detail informationen!
7FC42	0E	523330	14	923	DFC to indicate that wrong code is received. No detail informationen!
7FC56	04	523350	4	565	Injector cylinder-bank 1; short circuit
7FC58	04	523352	4	566	Injector cylinder-bank 2; short circuit
7FC5A	0C	523354	12	567	Injector powerstage output defect
7FCCE	02	523470	2	826	Pressure relief valve is forced to open, perform pressure increase.
7FCCE	02	523470	2	827	Pressure Relief Valve (PRV) forced to open. Performed by pressure increase.
7FCCE	07	523470	7	876	Maximum rail pressure exceeded (PRV).
7FCCE	0B	523470	11	831	Pressure Relief Valve (PRV) error; Rail pressure out of tolerance range.
7FCCE	0B	523470	11	832	"Rail pressure out of tolerance range. The PRV can not be opened at this operating point with a pressure shock."
7FCCE	0C	523470	12	828	Pressure Relief Valve (PRV) forced to open. Shutoff conditions.
7FCCE	0C	523470	12	829	Pressure Relief Valve (PRV) forced to open. Warning conditions.
7FCCE	0E	523470	14	830	Open Pressure Relief Valve (PRV)
7FD1E	0C	523550	12	980	Terminal 50 was operated too long
7FD51	0D	523601	13	948	Failure of sensor supply voltage 3.
7FD52	00	523602	0	462	High fan speed, warning threshold exceeded.
7FD52	00	523602	0	463	High fan speed, shut off threshold exceeded.
7FD53	09	523603	9	126	Timeout Error of CAN-receive-frame AMB; Ambient temperature sensor.
7FD55	09	523605	9	300	Timeout error of CAN-Receive-Frame TSC1AE. Traction Control.
7FD56	09	523606	9	301	Timeout error of CAN-Receive-Frame TSC1AR. Retarder.
7FD5C	03	523612	3	644	Reported Over Voltage of Supply
7FD5C	04	523612	4	646	Reported UnderVoltage of Supply
7FD5C	0C	523612	12	387	Internal software error ECU. Injection cut off.
7FD5C	0C	523612	12	612	Internal ECU monitoring detection reported error
7FD5C	0C	523612	12	613	"ECU reported internal software error Internal ECU monitoring detection reported error"
7FD5C	0C	523612	12	614	ECU reported internal software error
7FD5C	0C	523612	12	615	ECU reported internal software error.
7FD5C	0C	523612	12	616	ECU reported internal software error
7FD5C	0C	523612	12	617	ECU reported internal software error
7FD5C	0C	523612	12	618	ECU reported internal software error
7FD5C	0C	523612	12	619	Injection system,electrical error injectors
7FD5C	0C	523612	12	620	ECU reported internal software error
7FD5C	0C	523612	12	621	ECU reported internal software error
7FD5C	0C	523612	12	623	ECU reported internal software error
7FD5C	0C	523612	12	624	ECU reported internal software error
7FD5C	0C	523612	12	625	ECU reported internal software error

### 80.5.4 CUMMINS ENGINE FAULT DETECTION

The engine ECU detection port is under the protective grille in the cab, to the left of the cross beam (on the gearbox on the left).

There are two fault diagnosis switches:

- One fault control switch; 2 positions "ON" & "OFF";
  - ⇒ "ON" position to read the error codes;
  - ⇒ "OFF" position to record the error codes.
- A pulse switch (+) or (-) to run through the error codes.
  - ⇒ "+" pulse for reading the next error code on the dashboard;
  - ⇒ "-" pulse for reading the previous error code on the dashboard.

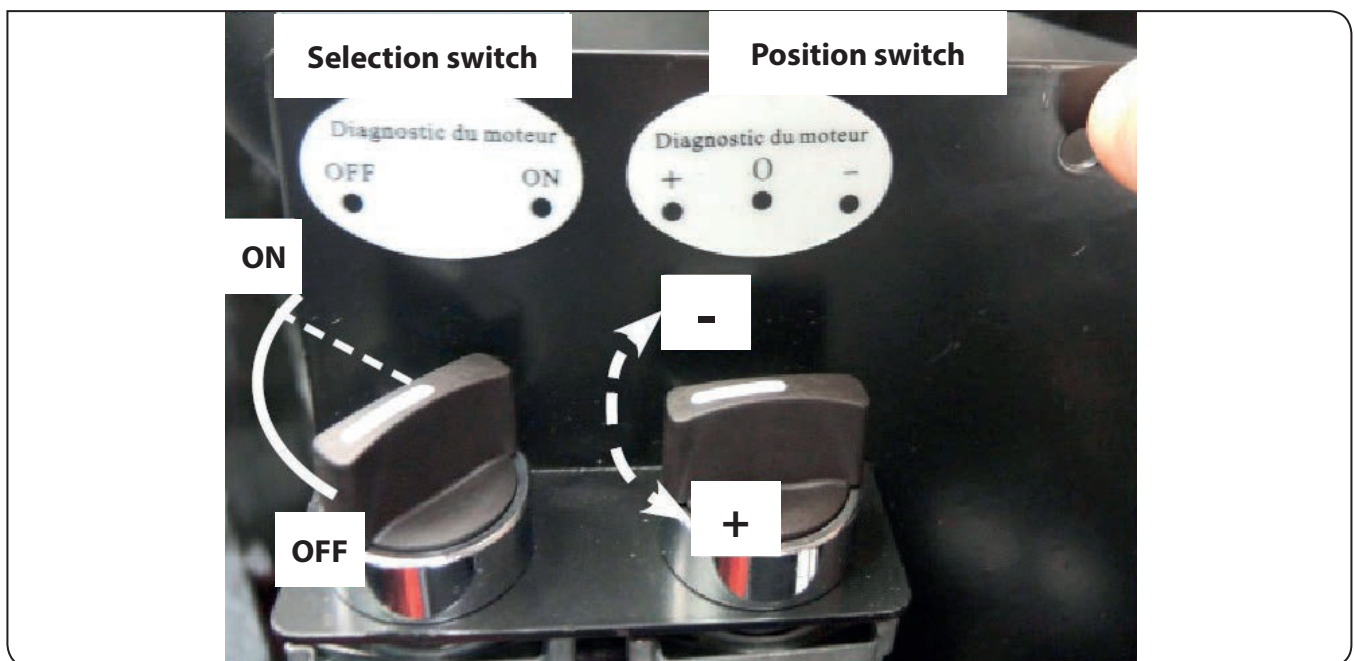

DTC 2		DTC PSI	Description
SPN	FMI		
110	0	217	ECT higher than expected stage 2
110	16	1521	CHT higher than expected stage 1
110	0	1522	CHT higher than expected stage 2
168	17	562	Vbat voltage low
168	15	563	Vbat voltage high
173	0	2428	EGT temperature high
174	4	182	FT voltage low
174	3	183	FT voltage high
441	3	1411	EMWT1 voltage high
441	4	1413	EMWT1 voltage low
441	15	1415	EMWT1 higher than expected stage 1
441	0	1417	EMWT1 higher than expected stage 2
442	3	1412	EMWT2 voltage high
442	4	1414	EMWT2 voltage low
442	15	1416	EMWT2 higher than expected stage 1
442	0	1418	EMWT2 higher than expected stage 2
443	3	1419	ERWT1 voltage high
443	4	1421	ERWT1 voltage low
443	15	1423	ERWT1 higher than expected stage 1
443	0	1425	ERWT1 higher than expected stage 2
444	3	1420	ERWT2 voltage high
444	4	1422	ERWT2 voltage low
444	15	1424	ERWT2 higher than expected stage 1
444	0	1426	ERWT2 higher than expected stage 2
515	15	219	RPM higher than max allowed govern speed
515	16	1111	RPM above fuel rev limit level
515	0	1112	RPM above spark rev limit level
558	5	2130	IVS stuck at-idle, FPP1/2 match
558	6	2131	IVS stuck off-idle, FPP1/2 match
628	13	601	Microprocessor failure - FLASH
629	31	606	Microprocessor failure - COP
629	31	1612	Microprocessor failure - RTI 1
629	31	1613	Microprocessor failure - RTI 2
629	31	1614	Microprocessor failure - RTI 3
629	31	1615	Microprocessor failure - A/D
629	31	1616	Microprocessor failure - Interrupt
630	12	604	Microprocessor failure - RAM
636	8	16	Crank and/or cam could not synchronise during start
636	2	336	CRANK input signal noise
636	4	337	Crank signal loss
639	12	1626	CAN-J1939 Tx fault
639	12	1627	CAN-J1939 Rx fault
639	13	1628	J1939 CAN address/engine number conflict
639	9	1629	J1939 TSC1 message receipt loss
645	4	2618	Tach output ground short
645	3	2619	Tach output short to power
651	5	261	Injector 1 open or short to ground
651	6	262	Injector 1 coil shorted
652	5	264	Injector 2 open or short to ground
652	6	265	Injector 2 coil shorted
653	5	267	Injector 3 open or short to ground
653	6	268	Injector 3 coil shorted
654	5	270	Injector 4 open or short to ground
654	6	271	Injector 4 coil shorted
655	5	273	Injector 5 open or short to ground
655	6	274	Injector 5 coil shorted
656	5	276	Injector 6 open or short to ground
656	6	277	Injector 6 coil shorted
657	5	279	Injector 7 open or short to ground
657	6	280	Injector 7 coil shorted
658	5	282	Injector 8 open or short to ground

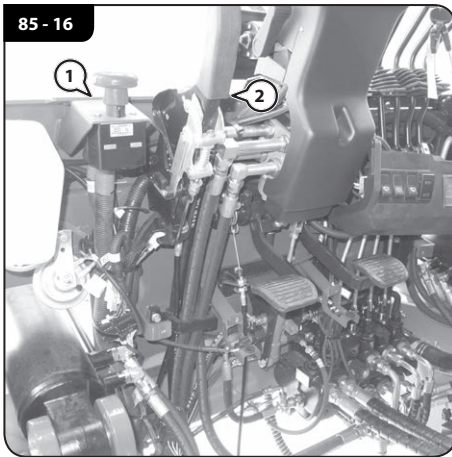

Take out the emergency stop button (1).

Remove the handbrake (2).

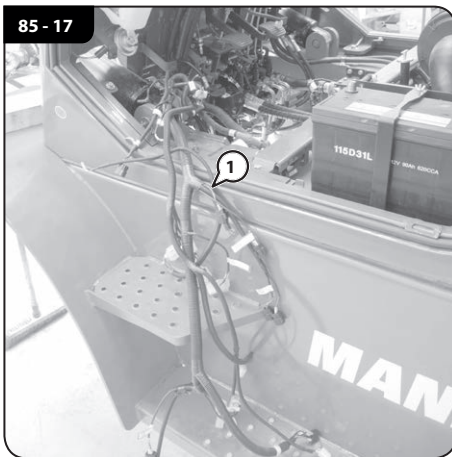

Check that the connectors are disconnected, then remove the electrical harness (1) and remove it from the truck.

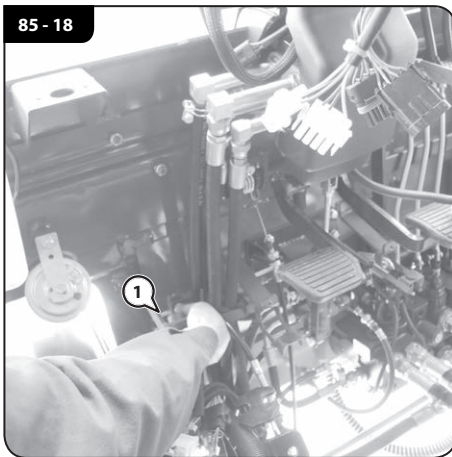

### **DISCONNECT THE HYDRAULIC CIRCUITS**

Remove the retaining flange (1) from the steering hoses.

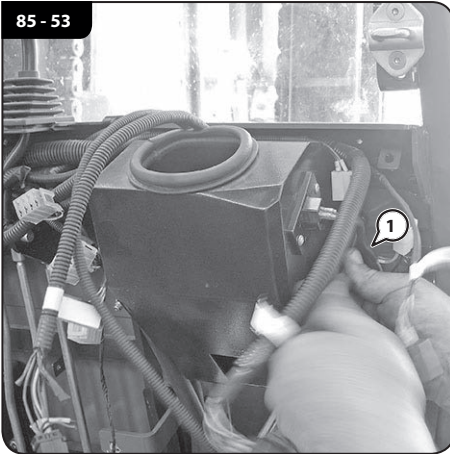

Remove the heater casing (1).

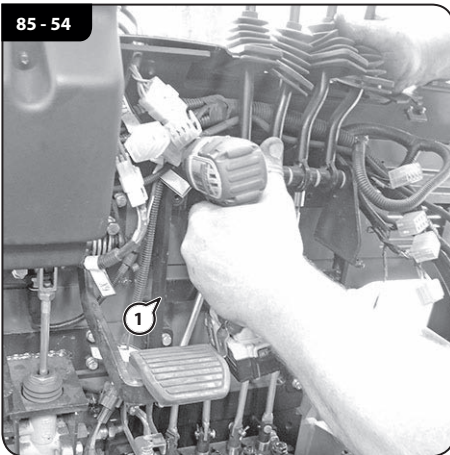

Undo the distributor lever bracket (1).



Identify all connectors (1).

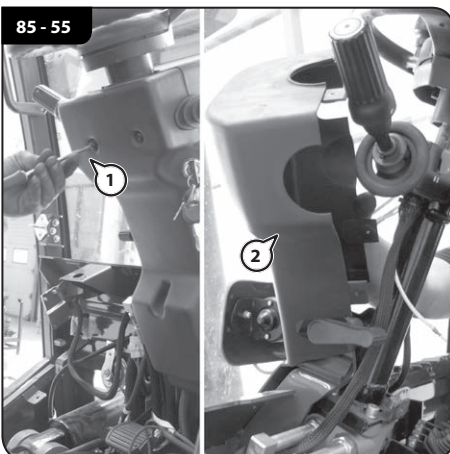

Remove the front (1) and rear (2) steering column cover.

CLICK HERE TO **DOWNLOAD** THE COMPLETE MANUAL

- Thank you very much for reading the preview of the manual.
- You can download the complete manual from: [www.heydownloads.com](http://www.heydownloads.com) by clicking the link below



- Please note: If there is no response to CLICKING the link, please download this PDF first and then click on it.

CLICK HERE TO **DOWNLOAD** THE COMPLETE MANUAL

## 90.2.2 REMOVE THE DRIVER'S SEAT COVER.

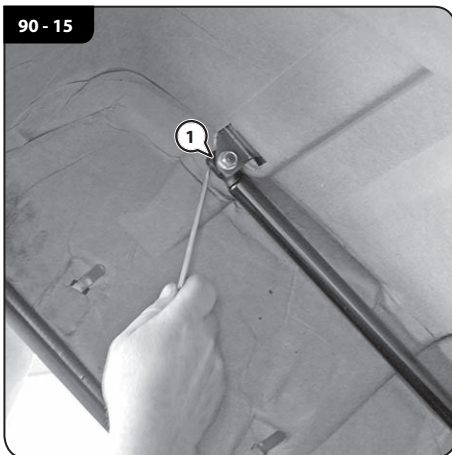

Remove the seat. (↩ **85.1.1 REMOVE THE DRIVER'S SEAT**, 📄 233)

Unclip the gas struts (1).



Unscrew the two knobs (1) to fully open the two door leaves.



First remove the air inlet (1) for the right door opening.



Gently raise the cover to remove the rear plate (1).



<i>MI 50L-60-70G-S2 &amp; US</i>						
<b>Engine specification</b>	7.1	Engine manufacturer / Type		PSI 4.3L CERT	PSI 4.3L CERT	PSI 4.3L CERT
	7.2	Useful power	hp (KW)	99 (74)	99 (74)	99 (74)
	7.3	Rated speed	rpm	2300	2300	2300
	7.4	Number of pistons/Capacity	cu.in. (cm3)	V6 / 262 (4300)	V6 / 262 (4300)	V6 / 262 (4300)
	7.5	Fuel consumption according to VDI cycle	gph (L/h)	3.9 (14.9)	3.9 (14.9)	3.9 (14.9)
<b>Miscellaneous</b>	8.2	Working hydraulic pressure for attachments	Psi (Bar)	2828 (195)	2828 (195)	2828 (195)
	8.3	Oil flow rate for attachments	gpm (L / min)	31.7 (120)	31.7 (120)	31.7 (120)
	8.4	Sound level at driver's ears according to DIN 12053	dB (A)	88	88	88
	8.5	Towing hook / DIN type		-	-	-
		Average weighted acceleration on driver's body (according to NF EN 13059)	m/s <sup>2</sup>	0.9	0.9	0.9
		Battery	V/Ah	12 / 90Ah	12 / 90Ah	12 / 90Ah
		Gas tank capacity	lb (kg)	29 (13)	29 (13)	29 (13)
		Transmission manufacturer		Hangcha	Hangcha	Hangcha
		Type		Powershift	Powershift	Powershift
		Number of speeds (F/R)		2 / 2	2 / 2	2 / 2



LINKS TO REPAIR MANUALS:

<b>MANUAL REFERENCE NUMBER</b>	<b>DESIGNATION</b>
647549EN	ENGINE DEUTZ AG - TCD 3.6 L4 _ (MI D - ST3B S2 - ST4 S2 & US)
647522EN	ENGINE PSI 4.3L _ (MI G S2)
647523EN	CUMMINS ENGINE QSB 3.3 & QSB 4.5 _ (MI-X D C ST3A S2)
647734EN	ENGINE PSI 4X _ (MI G S2 US)
647735EN	ENGINE PSI 4X MANUEL DE DÉPANNAGE _ (MI G S2 US)

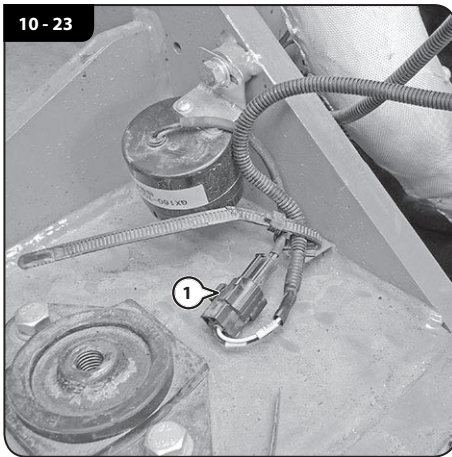

Disconnect the side buzzer (1).

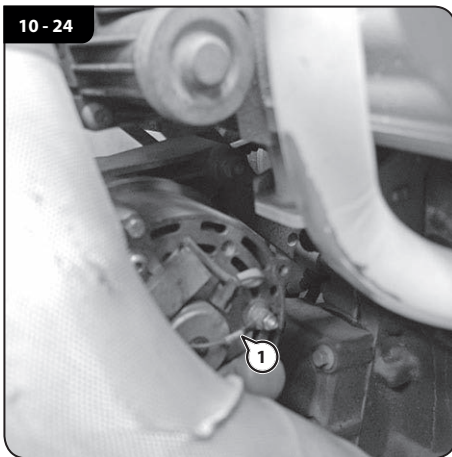

Disconnect the alternator wires (1).

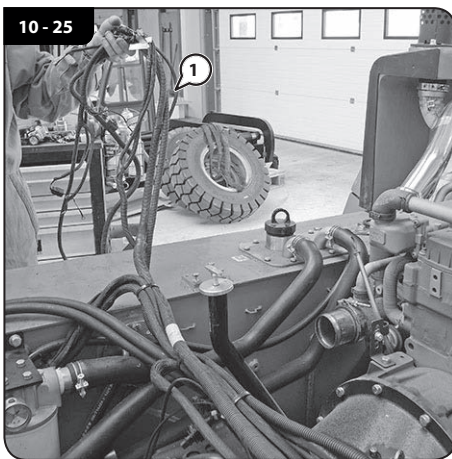

Disconnect all of the rear right connectors (1) after having identified them.

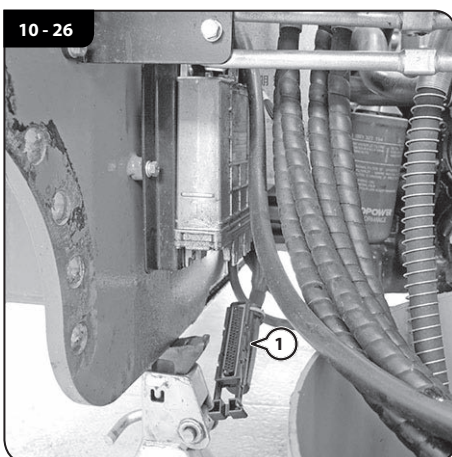

Disconnect the transmission ECU plug (1).

#### 10.4.4 REMOVE THE EXHAUST LINE.

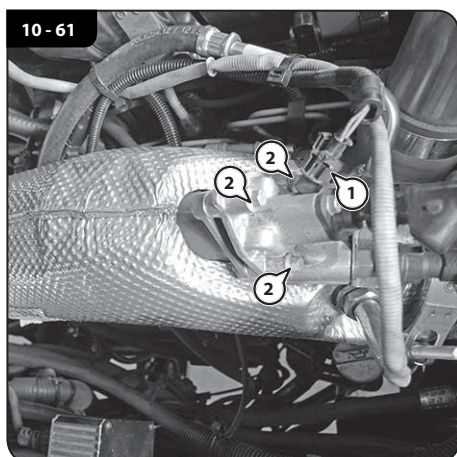

Remove the DEF injector.  
Important: Quickly replace the circuit components to avoid crystallisation of the DEF when exposed to air. If the circuit or some of its components are obstructed: rinse with hot water.

Disconnect the probe wire (1).

Remove the 3 fixing screws (2).

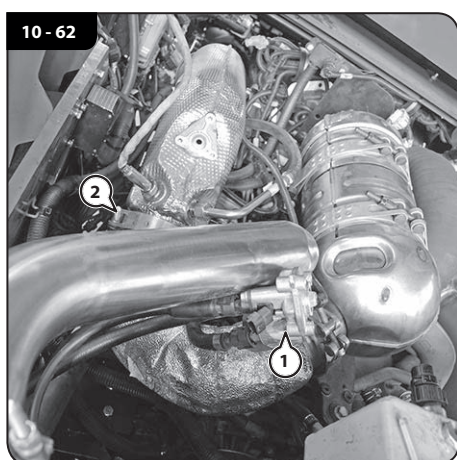

Set the block (1) aside.

Undo the clamp (2).

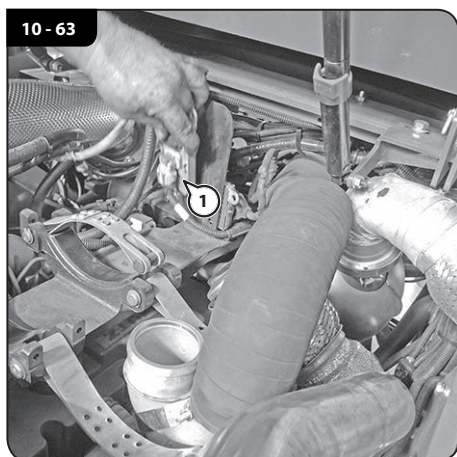

Remove the lambda sensor (1).

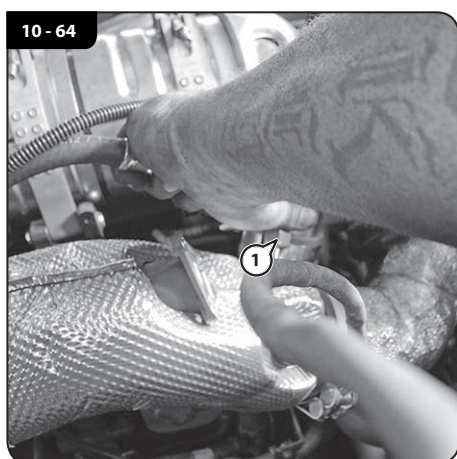

Disconnect the hose (1).

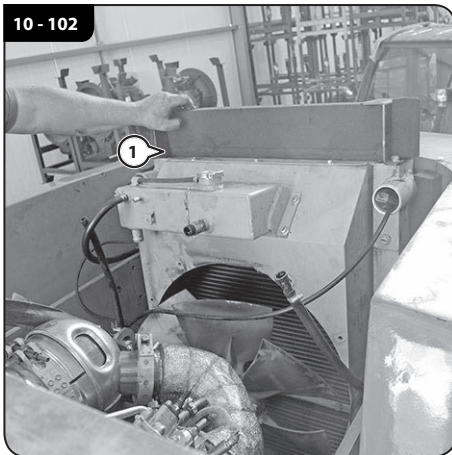

Tip the radiator backwards (1) to release the propeller.

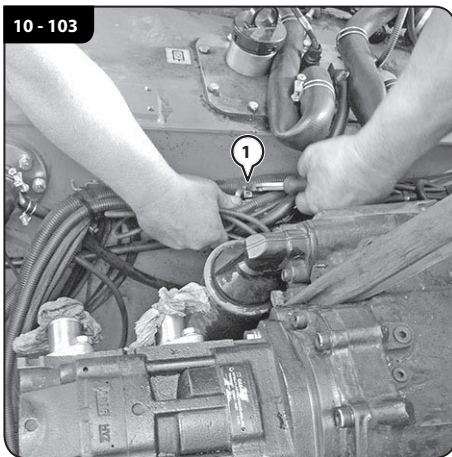

Cut some of the harness attachments (1).

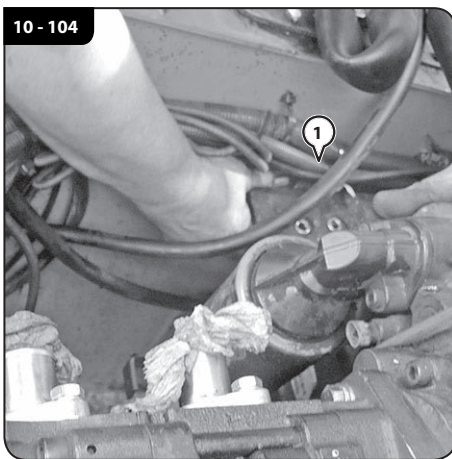

Start to lift up the engine-gearbox assembly to pass the harnesses through (1).

Lift up the engine-gearbox assembly (1).

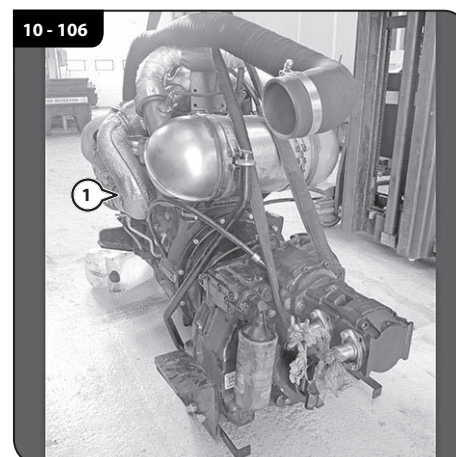
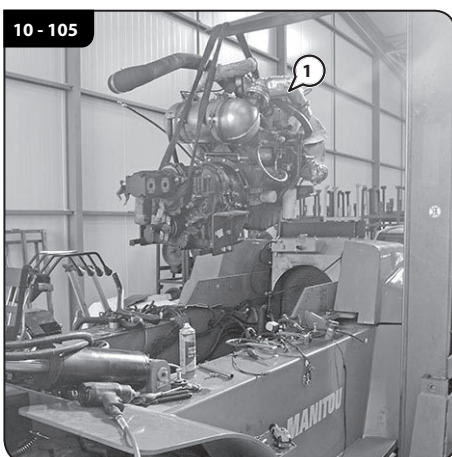

## 20.2.4 STRUCTURAL PRESENTATION

### HYDRODYNAMIC TRANSMISSION GEARBOX

#### Structural presentation

The figure presents the structure of the hydrodynamic transmission gearbox and the operating principles are described below.

Depending on the requirements of the vehicle in terms of performance, the hydrodynamic transmission gearbox comprises a torque converter and a gearbox. The engine's power comes from the torque of the torque converter transmitted to the forward clutch (12) of the gearbox, connected at the end of the turbine shaft. The gearbox has the following main components: the forward clutch (12), the reverse clutch (15), the tensioner (3), the pump drive gear (4), the oil pump assembly (5), the control valve assembly (9), the high speed (16), the low speed (17), the connecting flange (18), the output shaft (19), the internal expansion mechanical parking brake (20), the parking brake shaft (21) and the parking brake sprocket (22). Part (8) is the gearbox housing, which also acts as a fuel tank.

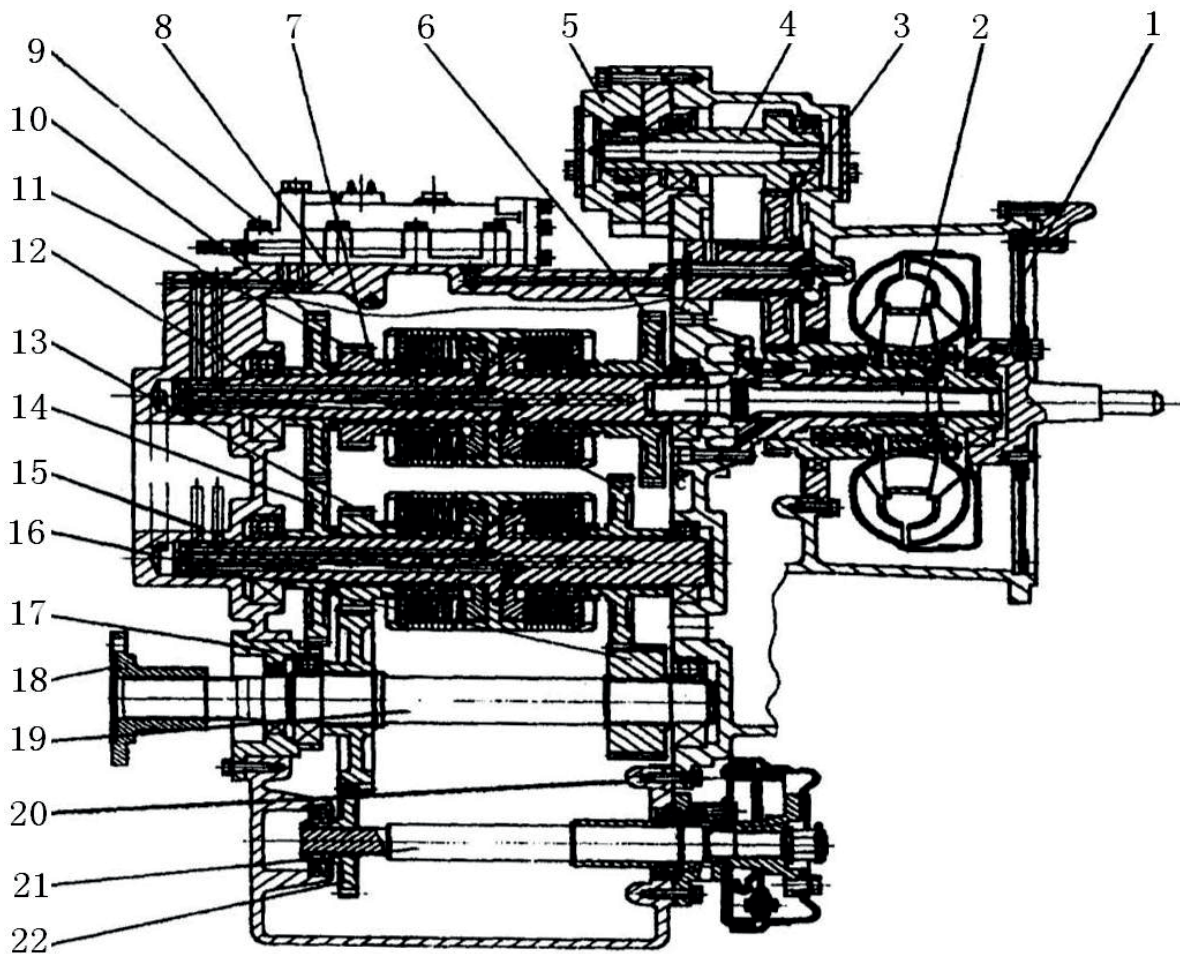

No.	Designation	No.	Designation	No.	Designation
1	Elastic connector plate	9	Control valve assembly	17	Low speed
2	Turbine shaft	10	Reverse gear	18	Connection flange
3	Tensioner	11	Reverse gear II	19	Output shaft
4	Pump drive gear	12	Forward clutch	20	Internal expansion mechanical parking brake
5	Oil pump assembly	13	Reverse gear I	21	Reverse clutch
6	Forward gear II	14	Reverse gear	22	Parking brake sprocket
7	Forward gear I	15	Reverse clutch	23	-
8	Casing	16	High speed	24	-

## 20.3.2 REMOVE THE GEARBOX. MI 80 - 100 D

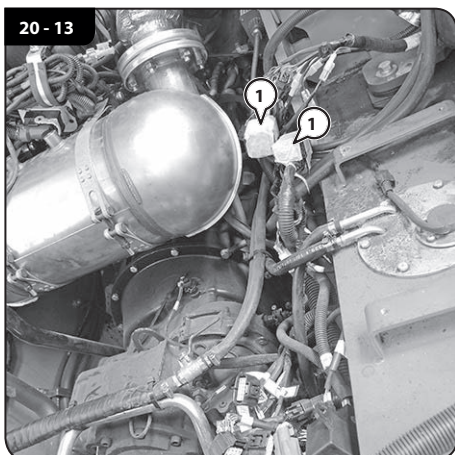

Remove the driver's seat cover. (◀ **90.2.2 REMOVE THE DRIVER'S SEAT COVER.**, ☞ 246)

Remove the batteries. (◀ **80.4.1 REMOVE THE BATTERIES.**, ☞ 184)

Remove the ECUs. (◀ **80.4.2 REMOVE THE ECUS.**, ☞ 185)

Hold the cables back (1).

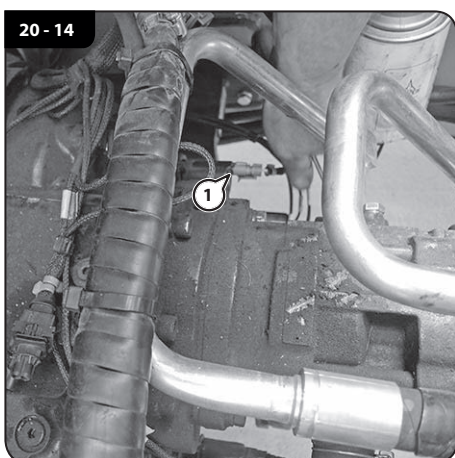

Identify and disconnect the connectors (1, ☞ 20 - 14)

& (1, ☞ 20 - 15).

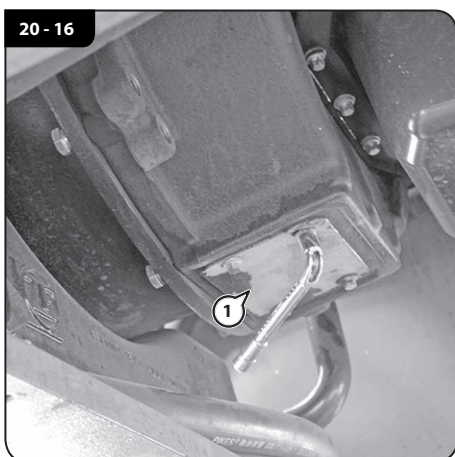
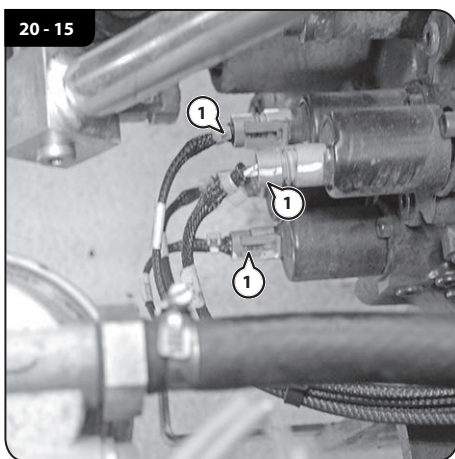

Remove the lower converter access panel (1).

	<i>REMOVE THE FRONT AXLE</i> .....	106
30.5.2	FRONT AXLE REMOVAL MI 80 - 100 D .....	107
	<i>REMOVE THE WHEELS</i> .....	107
	<i>REMOVE THE FRONT AXLE</i> .....	108
<b>30.6</b>	<b>STEERING AXLE REMOVAL - REFITTING</b> .....	<b>110</b>
30.6.1	REMOVING THE AXLE .....	110
<b>30.8</b>	<b>SPECIFIC TOOLING</b> .....	<b>110</b>
30.8.1	SQUARE SOCKET .....	110

- 4 - Choose an adjusting spacer for tightening the lock nuts to the recommended torque 343-441 N.m (253-325 ft-lb). The initial torque of the helical drive gear is 2.0-3.9 N.m (1.48-2.88 ft-lb).
- 5 - Remove the flange yoke and the cap (handbrake support) before pre-tightening.

Coat the oil seal in lubricant and fit it into the cap (handbrake support).

Fit the spacer ring and the flange yoke.

### **FITTING THE DIFFERENTIAL HOUSING**

Fit the left differential housing, facing the inner surface of the half-axle bearings.

Fit the half-axle gear and the matching side gear as well as the drive shaft and the corresponding adjusting spacer on the differential housing.

Measure the clearance between the half-axle gear and the side gear. (Clearance: 0.19-0.25 mm (0.0075-0.0098 in). If the clearance is not in this range, replace the side gear and the half-axle gear.)

#### **Warning**

When measuring, the side gear must not move.

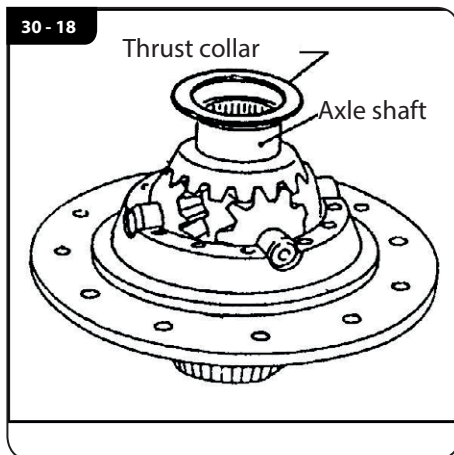

Install the half-axle gear and the stop washer.

The half-axle gear is fitted opposite the right differential housing.

Then make a mark on the differential housing.

Install the differential housing. Coat the attaching screws with Loctite and tighten to the recommended torque of 100 N.m (73.76 ft-lb).

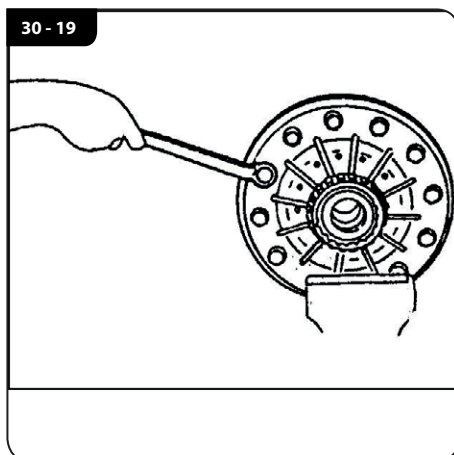

Install the helical drive gear. Coat the attaching screws with Loctite and tighten to the recommended torque of 120 N.m (88.51 ft-lb).

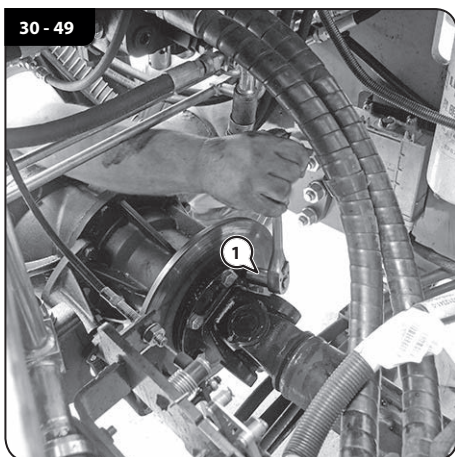

### REMOVE THE FRONT AXLE

Disconnect the universal joint (1).

Apply the handbrake to turn the disc.

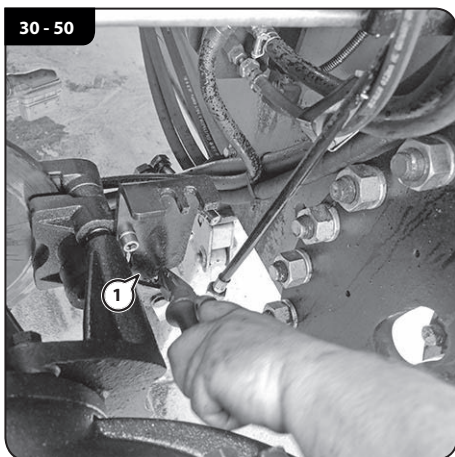

Remove the handbrake pin (1).

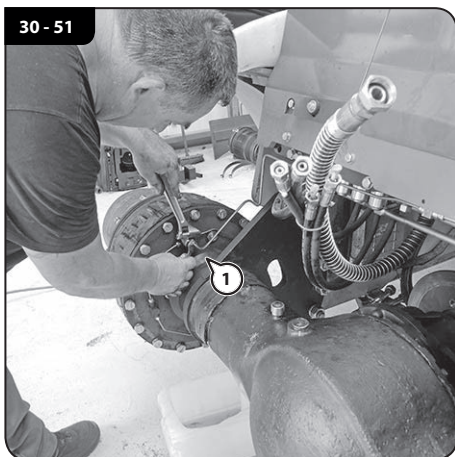

Unscrew the brake pipe at the axle (1).

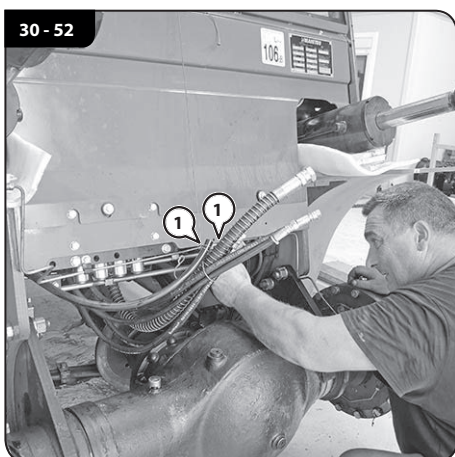

Undo the pipe at the central connector (1).

### 40.2.3 PARKING BRAKE LEVER

After use, if the travel of the lever has increased, braking is not as easy. It should be adjusted quickly.

Main aspects of adjustments:

- Adjust the internal expansion mechanical braking system before adjusting the parking brake;
- Install a brake cable and a fastening nut B;
- Adjust nut A until, when the lever is tightened, the force of the lever (point P) is greater than 15 kg (33.07 lb);
- Coat the guide C with enough universal automotive lithium grease.

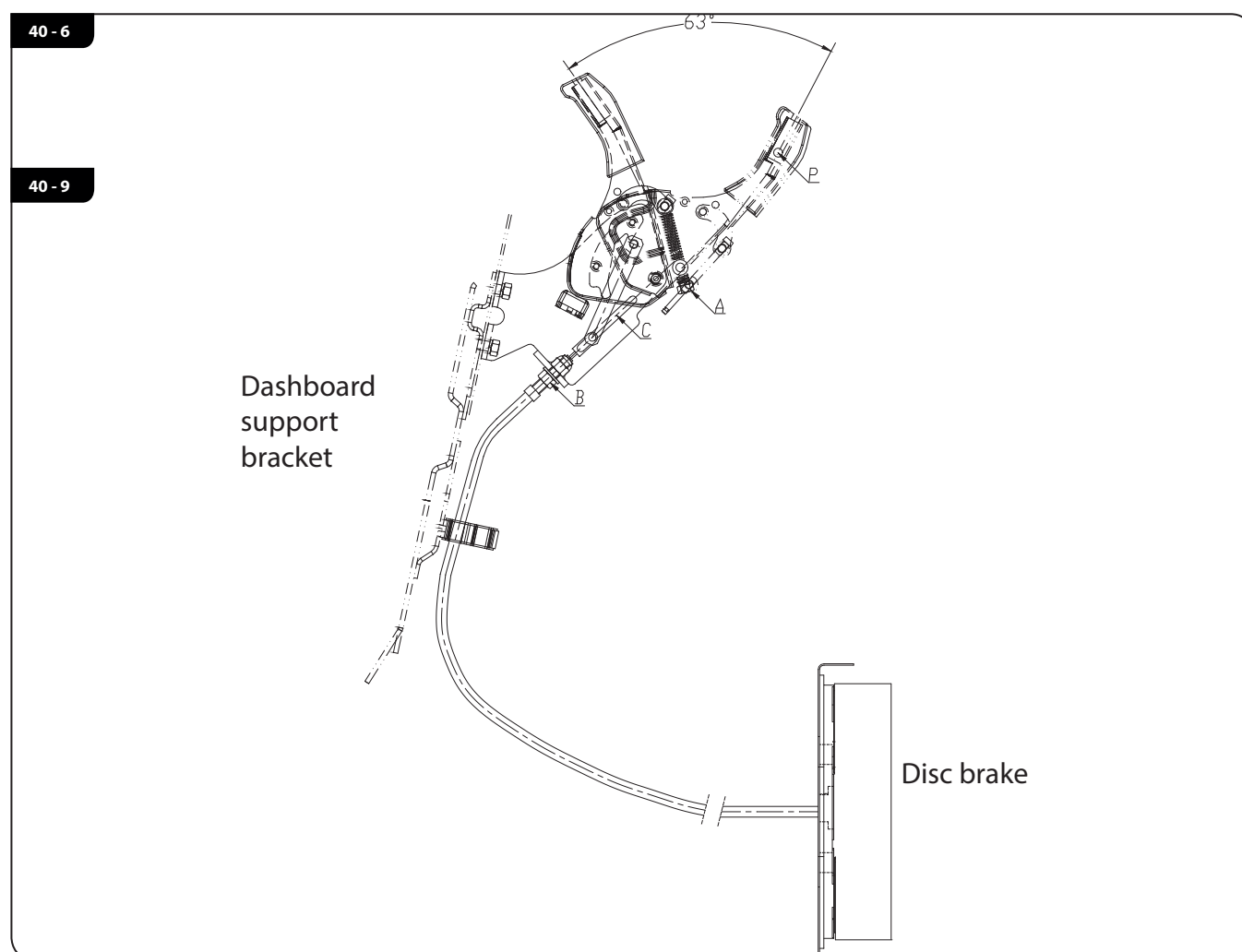

### 60.3.4 LIFTING CHAIN ADJUSTMENT

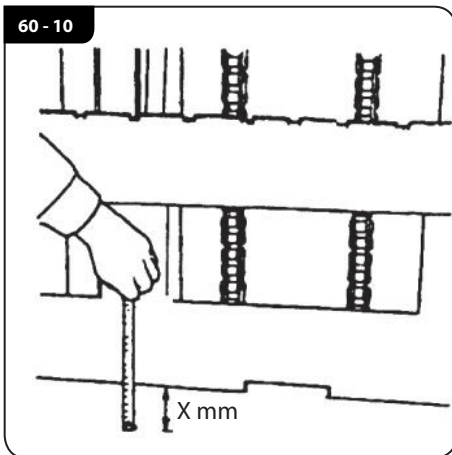

Insert the carriage into the inner mast.

Install the chain and screw the two nuts on the upper part.

Straighten the mast in vertical position and lower it completely.

Adjust the nut on the lower part of the chain so that the carriage plate under the forks is off the ground by X:

⇒ 5 t - 7 t = 127 mm (5 in).

⇒ 8 t - 10 t = 160 mm (5 in).

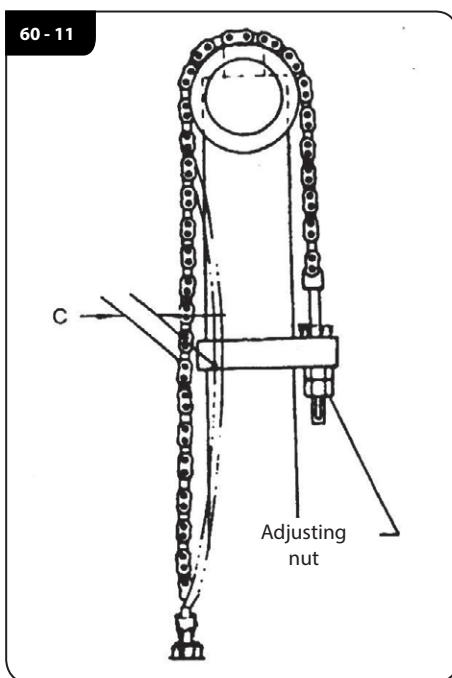

To adjust the chain tension, first lower the lifting cylinder until the forks touch the ground.

Adjust the chain using the adjusting nuts (three on each side).

Press with a finger in the middle of the chain to obtain a tension with a dimension of: (C: 25 mm (0.98 in) - 30 mm (1.18 in)).

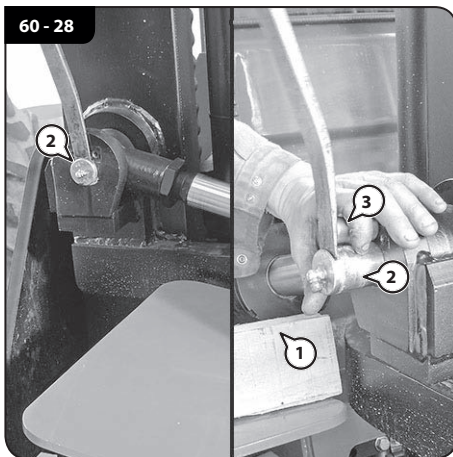

Wedge (1) under the tilting cylinders.

Take out the tilting cylinder head pivot pins (2).

Completely remove the pins using a spacer (3) or an extractor.



Release the mast (1).

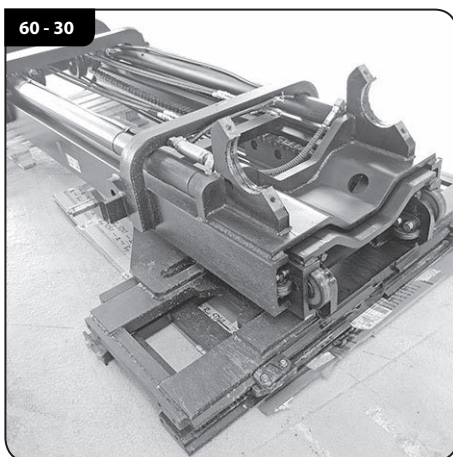

## 70.1.10 HYDRAULIC CONTROL VALVE

### STRUCTURE AND PRINCIPLE

The hydraulic control valve has several parts:

- ⇒ An inlet;
- ⇒ An outlet;
- ⇒ A slider mechanism.

The main pressure relief valve controls the oil pressure in the circuit. The pressure is set in the factory. The user should not adjust it arbitrarily.

The steering pressure relief valve is used to adjust the pressure in the power steering oil circuit. The slider mechanism controls the movements of the tilting, lifting and fork movement cylinders. Operation of the levers modifies the oil flow rate and enables the cylinders to be checked. The tilt blocking valve has a locking valve at the front.

### 3 TO 5-WAY VALVE BANK

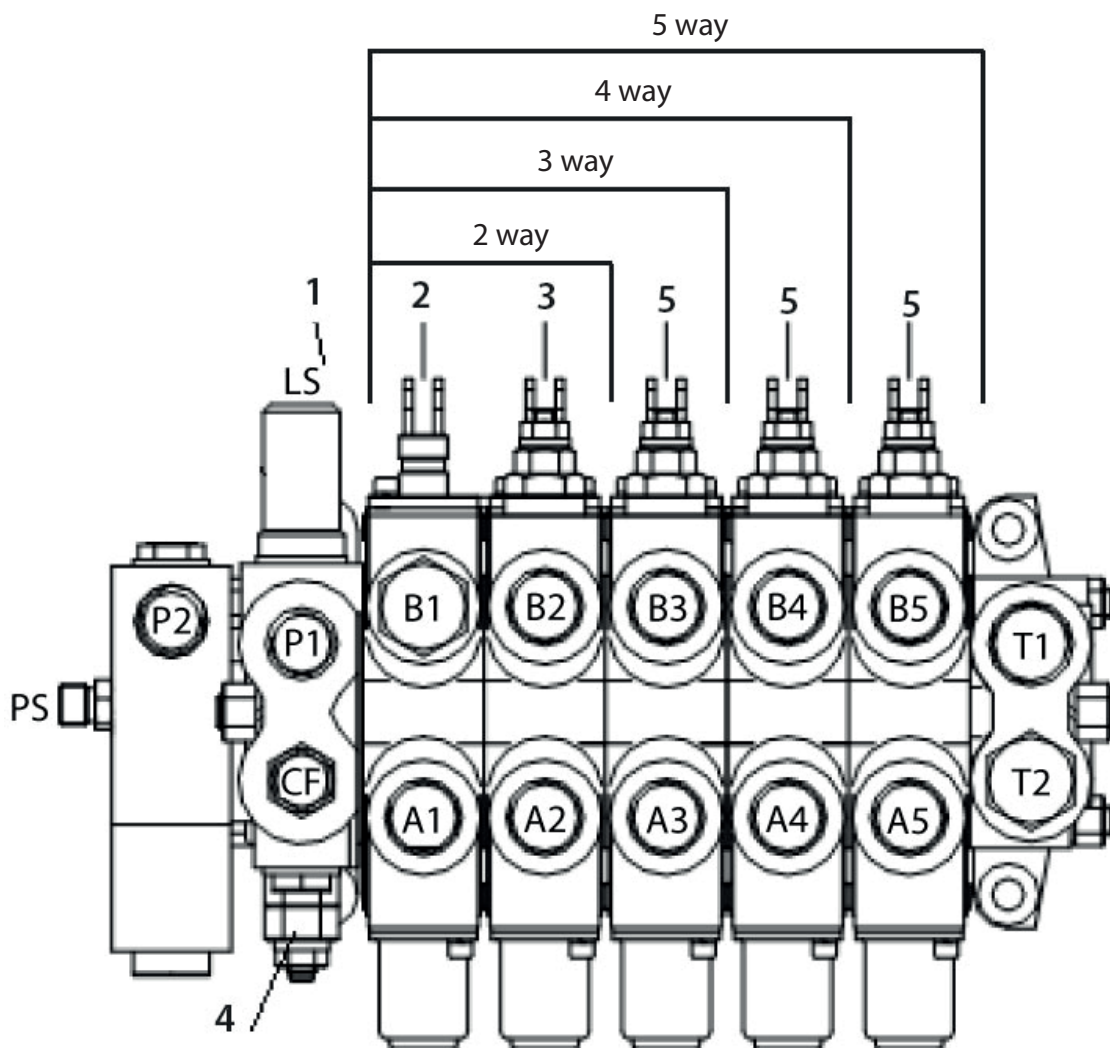

- 1 - Rotating safety valve (behind LS valve)
- 2 - Lifting cylinder
- 3 - Tilting cylinder

- 4 - Main safety valve
- 5 - Attachment elements

## 70.4.3 STEERING SYSTEM

<i>Faults</i>	<i>Causes</i>	<i>Symptoms</i>	<i>Means of elimination</i>
<b>Oil leaks</b>	Screws loose at the junction	-	Tighten the screws
	Sealing ring damaged on the junction surface or on the bearing shell	-	Replace the seal
	Adjusting washers damaged	-	Replace the adjusting washers
<b>Steering hard</b>	Not enough oil is supplied by the hydraulic pump	It is easy to turn the steering wheel slowly, but difficult to turn it quickly	Check if the hydraulic pump is working properly
	Air in the steering system	Foam in the oil, abnormal noises The steering wheel turns but the cylinders do not work	Remove the air from the system Check for leaks in the oil suction lines
	The oil level in the tank is below the required level	-	Add oil to the required level
	The oil viscosity is too high	-	Use the recommended oil
	The ball valve inside the valve box is not working	It is difficult to turn the steering wheel slowly and quickly and there is no pressure in the steering	Add steel balls if they are missing Clean them if they are jammed
	The pressure in the steering system is lower than the working pressure	Unladen or with a light load, the steering is light. It hardens as the load increases	Check the cause, restore or increase the pressure in the system (without exceeding 160 bar (2321.6 psi))
<b>The steering is not working properly</b>	The leaf spring is broken	The steering wheel does not come back automatically	Replace the leaf spring
	The pin extractor or the drive shaft is broken or deformed	The suspension pressure visibly increases until rotation becomes impossible	Replace the pin extractor or the linkage shaft
	The passage between the rotor and the linkage shaft is broken or deformed	The steering wheel turns on its own or swings from right to left	Linkage shaft gearing sticks with the wheel on the rotor hole that sticks
<b>Turns without human action</b>	The stator calibration diameter or the steering play is too great	While stopped and during rotation, the steering wheel turns but the cylinder does not work	Replace the stator

## 80.2 ELECTRICAL SCHEMATIC DIAGRAMS

### 80.2.1 MI 50L-60-70 D ST3B S2 & US

#### PARTS LIST

FUSES AND RELAYS			
Item	Current	Designation	Position in diagram
F1	50A		A2
F2	50A		A2
F3	20A		A4
F4	30A		A4
F5	10A		A5
F6	7.5A		A8
F7	5A		A8
F8	10A		A7
F9	10A		A14
F10	10A		A12
F11	10A		A10
F15	10A		H9
F16	20A		I9
K1		Starter relay	F1
K2		preheat relay	C3
K3		ignition relay	A3, F1
K4		neutral relay	C4
K5		Fuel relay	D4
K6		Forward/reverse switch relay	C8
K12		Tool relay	E11
K13		Indicator light relay	B12
K14		Headlight relay	C14
K15		Rear armrest warning relay	D12

COMPONENTS		
Item	Designation	Position on diagram
<b>G1</b>	Battery	C1
<b>G2</b>	Alternator	B1
<b>H01</b>	Horn	F11
<b>H02</b>	Reverse Warner	F8
<b>H03</b>	Horn	C11
<b>H1-1</b>	Front lamp	F14
<b>H1-2</b>	Front lamp	F13
<b>H1-3</b>	Front lamp	F13
<b>H2-1</b>	Front lamp	F14
<b>H2-2</b>	Front lamp	F14
<b>H2-3</b>	Rear lamp	F13
<b>H3-1</b>	Rear lamp	F14
<b>H3-2</b>	Rear lamp	F14
<b>H3-3</b>	Rear lamp	F13
<b>H3-4</b>	Rear lamp	F13
<b>H3-5</b>	Rear lamp	F12
<b>H3-6</b>	Rear lamp	F12
<b>H3-7</b>	Rear lamp	F8
<b>H3-8</b>	Rear lamp	F8
<b>H4-1</b>	Working light	F13
<b>H4-2</b>	Working light	F13
<b>H5</b>	Rotating beacon light	F12
<b>M1</b>	24V / 4KW Starter	D2
<b>M5</b>	Rear windscreen wiper motor	I11
<b>M6</b>	Rear windscreen washer motor	I12
<b>M7</b>	Fan engine	I13
<b>M8</b>	Windscreen wiper motor	J11
<b>M9</b>	Windscreen washer motor	J12
<b>P</b>	CAN display	E4, D7
<b>R1</b>	Preheat	D3
<b>S1</b>	Emergency stop button	B1
<b>S2</b>	Preheat and starter switch	A3
<b>S3</b>	Seat switch	B10
<b>S3~</b>	Seat belt switch	B10
<b>S4</b>	Parking brake switch	C9
<b>S5</b>	Automatic/Manual switch	C9
<b>S8</b>	Air filter switch	C7
<b>S9</b>	Lamp switch	C12
<b>S10</b>	Revolving light switch	C12
<b>S11</b>	Lighting switch	B14, C12
<b>S12</b>	Horn button	C11
<b>S13</b>	Rear armrest warning button	D12
<b>S14</b>	Accumulator alarm switch	C7

COMPONENTS		
Item	Designation	Position on diagram
<b>S101</b>	Water level sensor	C6
<b>S102</b>	Water-in-fuel alarm switch	C6
<b>S103</b>	Oil quality sensor	E7
<b>TB</b>	Electronic accelerator pedal	B6
<b>Y1</b>	Solenoid valve tool	F11
<b>OPTION</b>		
<b>CH1</b>	Roof light	H13
<b>CK1</b>	heating relay	H12
<b>CM1</b>	front windscreen wiper motor	J11
<b>CM2</b>	front windscreen washer motor	J12
<b>CM3</b>	rear windscreen wiper motor	I11
<b>CM4</b>	rear windscreen washer motor	I12
<b>CS1</b>	front windscreen wiper switch	J12
<b>CS2</b>	front windscreen washer switch	J12
<b>CS3</b>	rear windscreen wiper switch	I11
<b>CS4</b>	heating switch	H11
<b>CS5</b>	roof light switch	H11

COMPONENTS		
Item	Designation	Position on diagram
CH1	Sidelight	H9
CM1	Front windscreen wiper motor	I7
CM2	Front windscreen washer motor	I8
CM3	Rear windscreen wiper motor	I5
CM4	Rear windscreen washer motor	I6
CS1	Front windscreen wiper switch	I8
CS2	Front windscreen washer switch	I8
CS3	Rear windscreen wiper motor	I6
CS4	Heating switch	H5
CS5	Reading switch	H5
E02	Tutor system controller	E5
E06		B13
FT		A5
G1	12V 90Ah battery	A2
G2	24V 60A alternator	A7
H01	horn	I3
H02	Horn	F9
H03	Alarm	G9
H1_1	Front left position light	J9
H1_2	Front left direction indicator lights	G9
H2_1	Front right lamp	J9
H2_2	Front right direction indicator lights	G9
H3	35W front lamp	J9
H4	35W front lamp	J9
H5_1	Rear right position light	J9
H5_2	Rear right direction indicator lights	G9
H5_3	Right brake light	H9
H5_4	Right hand reverse light	F9
H6_1	Rear left position light	J9
H6_2	Rear left direction indicator lights	G9
H6_3	Left brake light	G9
H6_4	Left hand reverse light	F9
H8	Hazard warning light indicator	G9
H9	Working light	G9
H10	Charge indicator	C6
H11	Oil pressure indicator	D6
H12	Oil temperature indicator	D6
H13	Neutral position indicator	E6
H15	Fault indicator	C6
H16	Air filter indicator	D6
H17	Parking indicator	E6
M1	24V 4.5KW starter	B9
M5	Rear windscreen wiper motor	I5
M6	Rear windscreen washer motor	I6
M7	Fan engine	I9
M8	Windscreen wiper motor	I7
M9	Windscreen washer motor	I8
P1	24V water thermometer	D6
P2	24V fuel gauge	D6
P3	24V timer	D6
S1	Lighting switch	J5
S2	Horn button	I5
S3	Brake light switch	G5
S4	Hazard warning light switch	G5
S5	Indicator light switch	G5
S6	ALBIGHT	A1
S7	Preheat and starter switch	C2
S8	Accumulator switch	F2
S9	Seat switch	F2
S10	Handbrake switch	F2
S11	Rear work lamp switch	G5

COMPONENTS		
Item	Designation	Position on diagram
S102	Oil temperature sensor	D8
S103	Water temperature sensor	D8
S104	Fuel level sensor	D8
S106	Air filter alarm	D9
SF1	Forward switch	F2
SF2	High speed forward switch	E2
SR1	Shuttle	F2
SR2	High speed reversal switch	E2
TB	Accelerator pedal	C14
V1	2A / 600V diode	E3
V2	2A / 600V diode	E3
V3	2A / 600V diode	E3
V4	2A / 600V diode	E3
Y1	Forward electrovalve	E9
Y2	High speed electrovalve	E9
Y3	Reversal valve	E9
Y4	Mast lifting electrovalve	F9
Y5	Mast tilting electrovalve	F9
Y1	Forward electrovalve	E9
Y2	High speed electrovalve	E9
Y3	Reversal valve	E9
Y4	Mast lifting electrovalve	F9
Y5	Mast tilting electrovalve	F9

Controller EO2		
Input output	Colour	Designation
1	black	A1/ACC
1	grey	B+
2	black	Hand brake alarm
4	grey	Shuttle
4	black	Mast raise - lower
5	grey	high-to-low speed transfer
5	black	high speed electrovalve
6	grey	Accumulator
6	black	shuttle electrovalve
7	grey	handbrake switch
7	black	forward electrovalve
8	grey	Seat
8	black	Starter
9	grey	forward switch
9	black	Alarm
10	grey	
12	black	B-
B8		neutral indicator

## 80.2.6 MI 50L-60-70 G\_SINGLEFUEL

## PARTS LIST

FUSES AND RELAYS			
Item	Power	Designation	Position on diagram
F1		55A cable fuse	B1
F2		55A cable fuse	C1
F3	15A	Fuse	J2
F4	10A	Fuse	I2
F5	10A	Fuse	G2
F6	10A	Fuse	G2
F7	15A	Fuse	G2
F8	10A	Fuse	D2
F13	10A	Fuse	H2
F14	20A	Fuse	I2
K1		12V starter relay	B5
K3		12V light relay	J5
K5		12V neutral relay	E6
K6		12V shuttle relay	E7
K7		12V neutral relay	F7
K8		12V high-to-low speed change relay	E8
K9		Basing lifting mast 12V relay	F8
K11		12V indicator light	G5
K12		Heating relay	H6

Engine connector (EO6)	
Input output	Designation
1A	Acc
3C"	Charge indicator
5E	Oil pressure alarm indicator
6F	Starter relay signal
7G	Fault indicator
9J	accelerator pedal signal
10K	accelerator pedal signal
11L	Accelerator pedal ground
12M	Accelerator pedal switch
15R	Accelerator pedal ground
16S	Accelerator pedal switch

## 80.5 TROUBLESHOOTING

### 80.5.1 STARTER MAINTENANCE

<i>Engine</i>		
<i>Symptom</i>	<i>Cause</i>	<i>Treatment</i>
<b><i>The starter is not working</i></b>	The battery does not have enough capacity	Replace the batteries or charge them
	The starter circuit is interrupted	Repair or replace the wiring, the starter relay, etc.
	The electromagnetic switch is broken	Replace or repair the electromagnetic switch
	The gearing of the coil winding and the pinion gear is not correct	Replace or repair
	The contact with the brushes is not good	Adjust the position of the brushes, Clean the surface of the brushes
	The brushes are worn	Replace
<b><i>The starter turns but does not turn the engine</i></b>	The armature coil is disconnected	Replace the armature coil
	The pinion gear is faulty	Replace
	The coil winding spindle is not good	Repair

### 80.5.2 ALTERNATOR MAINTENANCE

<i>Electric generator</i>			
<i>Symptom</i>	<i>Cause</i>	<i>Treatment</i>	
<b><i>Charging light</i></b>	Charging impossible	The regulator is not working	Replace the regulator
		The magnetic field wiring is damaged	Replace
		The diode is not working	Replace
		The lug wiring is disconnected or the connection is poor	Repair or replace
		The fuses are damaged	Repair
	The charging current is low	The take-up reel is damaged	Replace
		The diode is not working	Replace
		Poor contact with the lugs	Repair or replace
		The machine's load is too high	Reduce the load
		The belt tension is not correct	Adjust
	The charging current is high	The regulator is not working	Replace
		The attachment on the current output return circuit is loose	Repair
	The battery electrolyte has decreased	The battery is not working	Replace or add liquid
	<b><i>Miscellaneous</i></b>	The engine is making an unusual noise	The regulator is not working
The contacts in the engine (bearings, brushes) are not good			Repair or replace
The drive belt tension is not correct			Adjust

DTC Engine Control Unit EDC17CV52					
Hexadecimal		Decimal		KWP Code	Description
SPN	FMI	SPN	FMI		
7FD71	0B	523633	11	881	Longterm adaption factor below threshold
7FD71	0B	523633	11	882	"Nox conversion rate insufficient (SCR-Cat defect, bad DEF quality)"
7FD71	0B	523633	11	883	"Nox conversion rate insufficient (SCR-Cat defect, bad DEF quality); temperature range 1"
7FDB2	0B	523698	11	122	Shut off request from supervisory monitoring function.
7FDB3	03	523699	3	780	Boost pressure control; negative governor deviation below limit
7FDB3	04	523699	4	781	"learning valu too high No detail informationen!"
7FDB8	0C	523704	12	167	Timeout error of CAN-Transmit-Frame EEC3.
7FDBA	0C	523706	12	178	Timeout error of CAN-Transmit-Frame FIEco.
7FDC5	0C	523717	12	125	Timeout error of CAN-transmit-frame AmbCon; Weather environments.
7FDC6	03	523718	3	1100	SCR main relay (primary side); short circuit to battery
7FDC6	03	523718	3	1488	SCR mainrelay; short circuit to battery (only CV56B)
7FDC6	04	523718	4	1101	SCR main relay (primary side); short circuit to ground
7FDC6	04	523718	4	1489	SCR mainrelay; short circuit to ground (only CV56B)
7FDC6	05	523718	5	1098	tank heating valve; open load
7FDC6	05	523718	5	1486	SCR mainrelay; open load (only CV56B)
7FDC6	0C	523718	12	1099	SCR main relay (primary side); powerstage over temperature
7FDC7	03	523719	3	1108	SCR heater DEF supplymodule; short circuit to battery
7FDC7	04	523719	4	1109	SCR heater DEF supplymodule; short circuit to ground
7FDC7	05	523719	5	1087	SCR heater relay DEF supply modul secondary side; open load
7FDC7	05	523719	5	1106	SCR heater relay DEF supplymodule primary side; open load
7FDC8	02	523720	2	914	"DEF supply module heater temperature; plausibility error (normal condition)."
7FDC8	02	523720	2	915	Sensor DEF supply module heater temperature; plausibility error (cold start condition)
7FDC8	08	523720	8	925	DEF supply module heater temperature; duty cycle in failure range.
7FDC8	08	523720	8	926	DEF supply module heater temperature; duty cycle in invalid range.
7FDC9	02	523721	2	916	"Sensor DEF supply module temperature; plausibility error (normal condition)"
7FDC9	02	523721	2	917	"Sensor DEF supply module temperature; plausibility error (cold start condition)"
7FDC9	08	523721	8	930	DEF supply module temperature; duty cycle in failure range.
7FDC9	08	523721	8	931	Urea supply module temperature; duty cycle in invalid range.
7FDC9	0B	523721	11	927	Urea supply module temperature measurement not available.
7FDCA	08	523722	8	928	DEF supply module PWM signal; period outside valid range.
7FDCA	08	523722	8	929	Detect faulty PWM signal from Supply Modul.
7FDDD	0E	523741	14	172	Engine shut off request through CAN.
7FDE8	00	523752	0	692	"Plausibiliti error during Rich to Lean switch over No detail informationen!"
7FDE8	00	523752	0	693	"Monitoring of Nox signal readiness No detail informationen!"
7FDEC	0E	523756	14	575	"special pattern for special cases No detail informationen!"
7FDED	0E	523757	14	576	"special pattern for special cases No detail informationen!"
7FDEE	0E	523758	14	577	"special pattern for special cases No detail informationen!"
7FDEF	0E	523759	14	578	"special pattern for special cases No detail informationen!"
7FDF0	0E	523760	14	579	"special pattern for special cases No detail informationen!"
7FDF6	09	523766	9	281	Timeout error of CAN-Receive-Frame Active TSC1AE.
7FDF7	09	523767	9	282	Timeout error of CAN-Receive-Frame Passive TSC1AE.
7FDF8	09	523768	9	283	Timeout error of CAN-Receive-Frame Active TSC1AR.
7FDF9	09	523769	9	284	Timeout error of CAN-Receive-Frame Passive TSC1AR.
7FE00	09	523776	9	291	Timeout error of CAN-Receive-Frame TSC1TE - active.
7FE01	09	523777	9	292	Passive timeout error of CAN-Receive-Frame TSC1TE. Setpoint.
7FE02	09	523778	9	293	Timeout error of CAN-Receive-Frame TSC1TR.
7FE03	09	523779	9	294	Passive timeout error of CAN-Receive-Frame TSC1TR.
7FE0C	00	523788	0	1299	Wastegate plausibility error off CAN transmit message.
7FE0C	00	523788	0	1300	Timeout Error of CAN-Receive-Frame ComTrbChActr; Wastegate
7FE0C	0C	523788	12	299	Timeout error of CAN-Transmit-Frame TrbCH. Status Wastegate.
7FE11	09	523793	9	202	Timeout error of CAN-Receive-Frame UAA10. AGS sensor service message.
7FE12	09	523794	9	203	Timeout error of CAN-Receive-Frame UAA11. AGS sensor data.
7FE1B	09	523803	9	212	Timeout error of CAN-Receive-Message RxEngPres. Status Burner Air Pump.

## 80.5.5 CUMMINS ENGINE FAULT CODES (DTC)

### ENGINE ECU ERROR CODES LIST

<i>DTC Engine ECU CUMMINS – STAGE IIIB</i>				
<i>FAULT CODE {INDICATOR}</i>	<i>J1939 SPN (S) {FMI}</i>	<i>COLOUR INDICATOR</i>	<i>DESCRIPTION J1939 SPN</i>	<i>CUMMINS DESCRIPTION</i>
111	629 {12}	Red	Controller 1	Electronic control module critical internal failure – Bad intelligent device or component.
115	612 {2}	Red	System 2 diagnostic code	Engine magnetic speed/position lost both of two signals – Data erratic, intermittent, or incorrect.
122	102 {3}	Amber	Boost pressure	Intake manifold 1 pressure sensor circuit – Voltage above normal or shorted to high source.
123	102 {4}	Amber	Boost pressure	Intake manifold 1 pressure sensor circuit – Voltage below normal or shorted to low source.
131	91 {3}	Red	Accelerator pedal position	Accelerator pedal or lever position sensor 1 circuit – Voltage above normal or shorted to high source.
132	91 {4}	Red	Accelerator pedal position	Accelerator pedal or lever position sensor 1 circuit – Voltage below normal or shorted to low source.
133	974 {3}	Red	Remote accelerator	Remote accelerator pedal or lever position sensor 1 circuit – Voltage above normal or shorted to high source.
134	974 {4}	Red	Remote accelerator	Remote accelerator pedal or lever position sensor 1 circuit – Voltage below normal or shorted to low source.
135	100 {3}	Amber	Engine oil pressure	Engine oil rifle pressure 1 sensor circuit – Voltage above normal or shorted to high source.
141	100 {4}	Amber	Engine oil pressure	Engine oil rifle pressure 1 sensor circuit – Voltage below normal or shorted to low source.
143	100 {18}	Amber	Engine oil pressure	Engine oil rifle pressure – Data valid but below normal operational range – Moderately severe level.
144	110 {3}	Amber	Coolant temperature	Engine coolant temperature 1 sensor circuit – Voltage above normal or shorted to high source.
145	110 {4}	Amber	Coolant temperature	Engine coolant temperature 1 sensor circuit – Voltage below normal or shorted to low source.
146	110 {16}	Amber	Coolant temperature	Engine coolant temperature – Data valid but above normal operational range – Moderately severe level.
147	91 {1}	Red	Accelerator pedal position	Accelerator pedal or lever position sensor 1 circuit frequency – Data valid but below normal operational range – Most severe level.
148	91 {0}	Red	Accelerator pedal position	Accelerator pedal or lever position sensor 1 – Data valid but above normal operational range – Most severe level.
151	110 {0}	Red	Coolant temperature	Engine coolant temperature – Data valid but above normal operational range – Most severe level.
153	105 {3}	Amber	Intake manifold 1 temperature	Intake manifold 1 temperature sensor circuit – Voltage above normal or shorted to high source.

DTC 2		DTC PSI	Description
SPN	FMI		
1321	4	616	Start relay ground short
1321	3	617	Start relay short to power
1323	31	301	Cylinder 1 emissions/catalyst damaging misfire
1323	11	1311	Cylinder 1 misfire detected
1324	31	302	Cylinder 2 emissions/catalyst damaging misfire
1324	11	1312	Cylinder 2 misfire detected
1325	31	303	Cylinder 3 emissions/catalyst damaging misfire
1325	11	1313	Cylinder 3 misfire detected
1326	31	304	Cylinder 4 emissions/catalyst damaging misfire
1326	11	1314	Cylinder 4 misfire detected
1327	31	305	Cylinder 5 emissions/catalyst damaging misfire
1327	11	1315	Cylinder 5 misfire detected
1328	31	306	Cylinder 6 emissions/catalyst damaging misfire
1328	11	1316	Cylinder 6 misfire detected
1329	31	307	Cylinder 7 emissions/catalyst damaging misfire
1329	11	1317	Cylinder 7 misfire detected
1330	31	308	Cylinder 8 emissions/catalyst damaging misfire
1330	11	1318	Cylinder 8 misfire detected
1347	5	628	Fuel-pump high-side open or short to ground
1347	6	629	Fuel-pump high-side open or short to power
1348	5	627	Fuel pump relay coil open
1348	4	628	Fuel-pump relay control ground short
1348	3	629	Fuel pump relay coil short to power
1384	31	1625	J1939 shutdown request
1485	5	685	Power relay coil open
1485	4	686	Power relay ground short
1485	3	687	Power relay coil short to power
1692	0	234	Boost control failure
1692	2	236	TIP active
1692	1	299	Boost control underboost failure
2646	5	1665	PWM8 open/ground short
2646	3	1666	PWM8 short to power
2647	5	1669	PWM9 open/ground short
2647	3	1670	PWM9 short to power
3056	3	8906	UEGO return voltage shorted high
3056	4	8907	UEGO return voltage shorted low
3217	3	8910	UEGO sense cell voltage high
3217	4	8911	UEGO sense cell voltage low
3218	3	8908	UEGO pump voltage shorted high
3218	4	8909	UEGO pump voltage shorted low
3221	31	8901	UEGO microprocessor internal fault
3221	3	8904	UEGO cal resistor voltage high
3221	4	8905	UEGO cal resistor voltage low
3222	3	8902	UEGO heater supply high voltage
3222	4	8903	UEGO heater supply low voltage
3222	10	8914	UEGO sensor cell slow to warm up
3222	0	8916	UEGO sensor cell impedance high
3225	3	8912	UEGO pump voltage at high drive limit
3225	4	8913	UEGO pump voltage at low drive limit
3225	10	8915	UEGO pump cell slow to warm up
3225	0	8917	UEGO pump cell impedance high
3225	1	8918	UEGO pump cell impedance low
520200	0	171	Adaptive-learn petrol bank1 high
520200	1	172	Adaptive-learn petrol bank1 low
520201	0	174	Adaptive-learn petrol bank2 high
520201	1	175	Adaptive-learn petrol bank2 low
520202	0	1161	Adaptive-learn LPG high
520202	1	1162	Adaptive-learn LPG low
520203	0	1163	Adaptive-learn NG high
520203	1	1164	Adaptive-learn NG low
520204	0	1155	Closed-loop petrol bank1 high

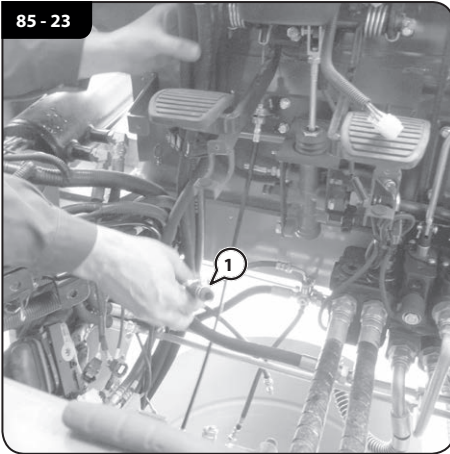

Disconnect the steering pump return hose (1).

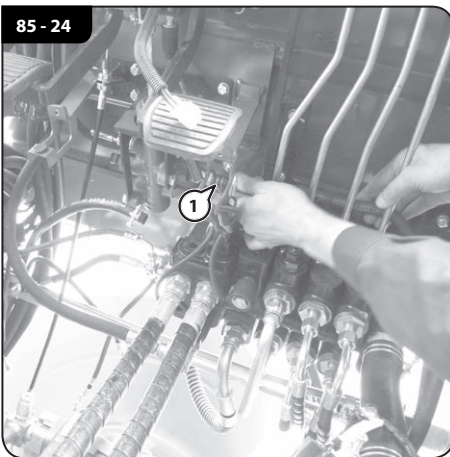

Disconnect the control valve return hose (1).

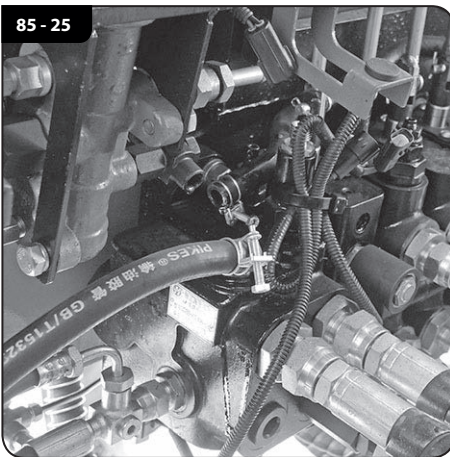

Disconnect the control valve steering head power supply.

Remove the air filter. (◀ **10.3.2 REMOVE THE AIR FILTER**,  33)



Remove the rear left casing (1).

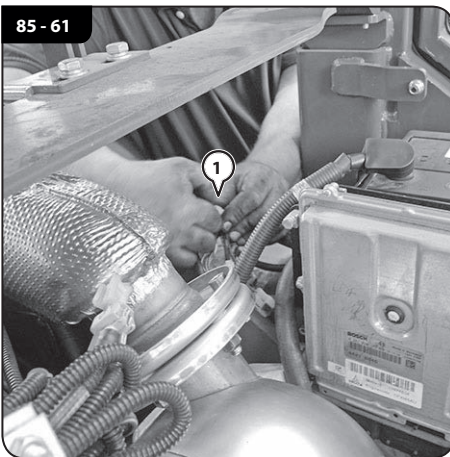

Disconnect the cab harness (1) on the rear left-hand side.

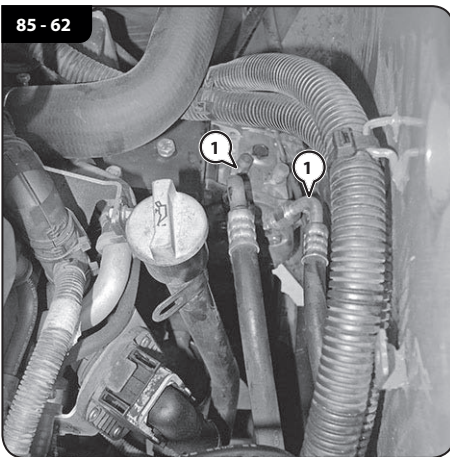

Remove the air-conditioning hoses (1).

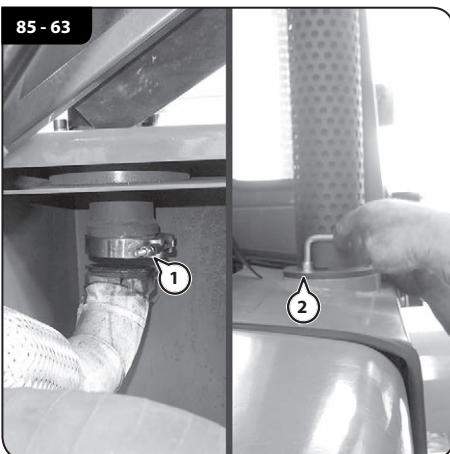

Remove the muffler (1 & 2).

CLICK HERE TO **DOWNLOAD** THE COMPLETE MANUAL

- Thank you very much for reading the preview of the manual.
- You can download the complete manual from: [www.heydownloads.com](http://www.heydownloads.com) by clicking the link below



- Please note: If there is no response to CLICKING the link, please download this PDF first and then click on it.

CLICK HERE TO **DOWNLOAD** THE COMPLETE MANUAL