

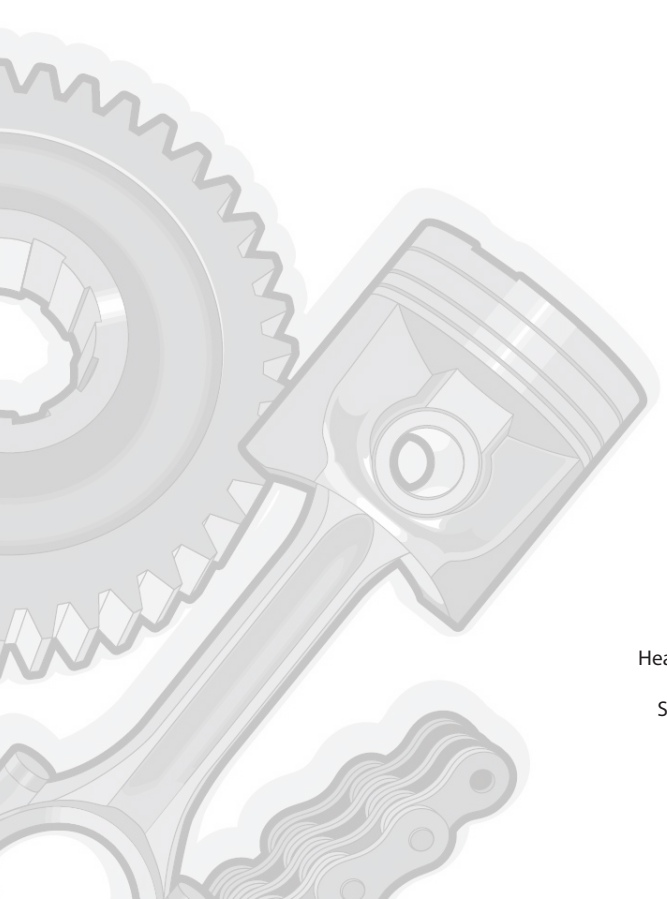

**REPAIR MANUAL  
MANUEL DE RÉPARATION  
REPARATURANLEITUNG  
MANUAL DE REPARACIÓN  
MANUALE RIPARAZIONE**

This document has been printed from  **mye doc**



**MANITOU BF**

Head office: 430, Rue de l'Aubinière  
44150 Ancenis - FRANCE  
Share capital: 39,548,949 euros  
857 802 508 RCS Nantes  
Tel: +33 (0)2 40 09 10 11  
[www.manitou.com](http://www.manitou.com)

CLICK HERE TO **DOWNLOAD** THE COMPLETE MANUAL

- Thank you very much for reading the preview of the manual.
- You can download the complete manual from: [www.heydownloads.com](http://www.heydownloads.com) by clicking the link below



- Please note: If there is no response to CLICKING the link, please download this PDF first and then click on it.

CLICK HERE TO **DOWNLOAD** THE COMPLETE MANUAL

**Transmission**

- Type Hydrostatic
- Type Pump and motor with variable displacement
- Gear box hydraulically operated
  - N° of forward speeds 2
  - N° of reverse speeds 2
- Reverser Electrohydraulic

**Hydraulic circuit**

- Lifting, tilting of telescopic boom and device
- Type of pump Piston type-load sensing
- Delivery 165 l/min
- Pressure 350 bar

**Steering circuit**

- Type of pump Load sensing
- Delivery 165 l/min
- Pressure 205 bar

**Leveling circuit**

- Type of pump Gear pump
- Delivery 25 l/min
- Pressure 205 bar

**Cooling circuits**

Water and intercooler by hydraulic motor

- Type of pump Gear pump
- Delivery 25 l/min
- Pressure 175 bar

Hydraulic oil

- Electrical fan Number 4

**Front and rear tyre:**

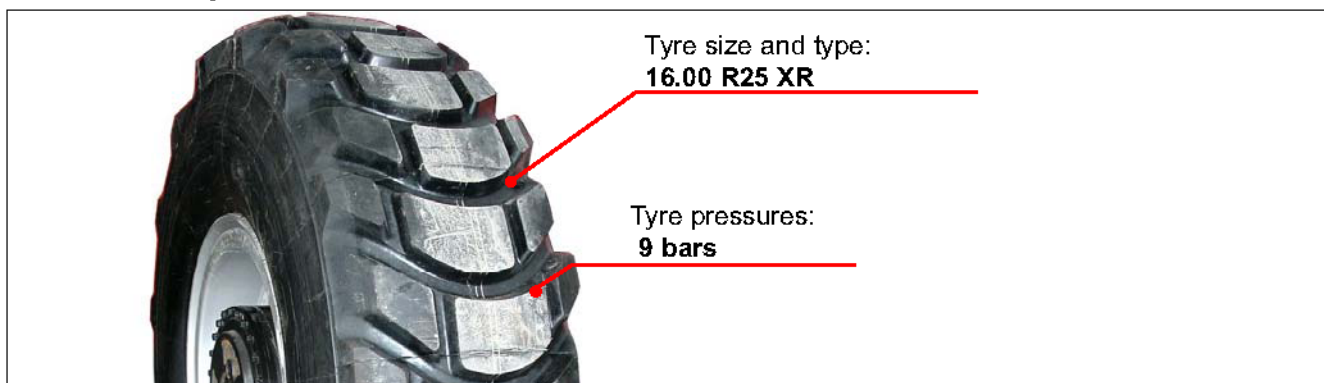

## ***TRANSMISSION OPERATION (REGULATION)***

---

## “DA” CONTROL CARTRIDGE OPERATION

The pilot pressure is drawn via the control cartridge slide valve into the booster circuit. At maximum IC engine speed, the pilot pressure is a few bars lower than the booster pressure.

On idling (850 rpm) the booster flow which passes through the calibrated opening in the control cartridge slide valve is sufficient to create a drop in pressure capable of displacing the slide valve 1 against the force of the spring 2. The pilot pressure is therefore nil.

When the operator accelerates in order to move forward (to approximately 1050 rpm), the booster flow increases; the drop in pressure before the calibrated opening is now sufficient to move the slide valve to the left, against the spring, thus revealing the pilot opening.

When the pilot pressure reaches approximately 6 to 7 bar, the servocontrol cylinder begins to move, tilting the plate of the variable capacity pump. The pump begins to discharge (start of control). The greater the engine speed, the more the booster flow increases thus increases thus leading to a rise in the pilot pressure and therefore increased influence on the pump and greater machine speed.

To halt this process, the operator stops accelerating, the booster flow drops, the pressure drop is reduced and the spring 2 pushes back the slide valve 1 thus closing the booster passage to the pilot conduit. The residual pilot pressure is discharged towards the housing.

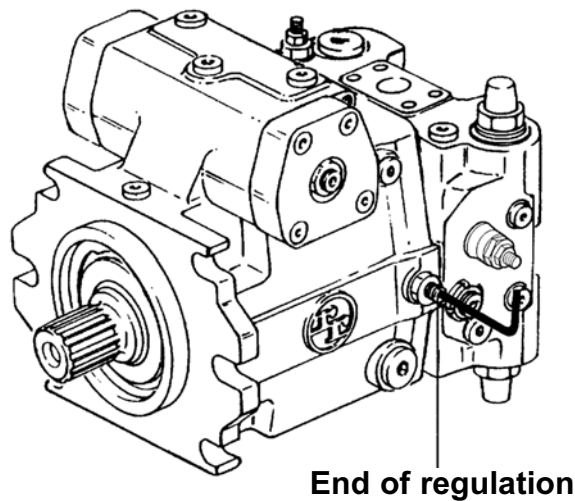
**3B CHECK AND ADJUST END OF REGULATION:****CHECK:**

- The truck is supported on blocks, inching valve by passed, brakes applied (foot and park).
- Drive reverser in forward drive.
- Select forward drive.
- Engine at low idle-check rpm.
- Gradually increase the engine speed (1600÷1800rpm) until the forward HP reading is 465 bar. At this point check engine speed and compare with specifications.

**END OF REGULATION:**

The adjustment of the pump end of regulation is obtained using an eccentric screw which restricts the pump flow creating back pressure against the swash plate.



**This adjustment can only be set using a test bench.**

**It cannot be modified in any way without prior authorization from the manufacturer.**

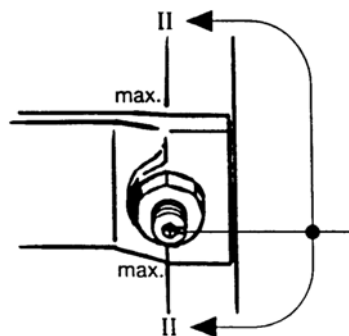

**The slot in the eccentric screw should point towards the boost pump(opposite to A4VG pump where slot pointed to drive shaft). The adjustment must not go beyond 90 to the left or right-Do not exceed or damage may occur.**

**As for the HP adjustment, this adjustment has to be done with the DR valve overcalibrated.**

# *UNIT 4*

# ***AXLES***

### 1.2 - Identification data

Exact reference to the "Model", the "Serial number" and the "Year of Manufacture" of the axle is required when requests for assistance under guarantee are needed or when spare parts are ordered.

These data are written in the plate (fig.1.2), located as shown in fig.1.3. Always refer to the axle data whenever you contact the after-sales service. This will enable immediate replies, while eliminating the risk of misunderstanding and uncertainties in the solution of your problem.

As memorandum we suggest to write down all the axle data.

### 1.3 - Packing and movement

#### 1.3.1 - Packing

Before delivery the axle is accurately inspected. Except for special request or particular shipment as naval transport, the axle is shipped without packing.

#### 1.3.2 - Movement

Axle lifting and transport must be done using suitable means. The axle type AS 372 KR weighs about 1450 kg.

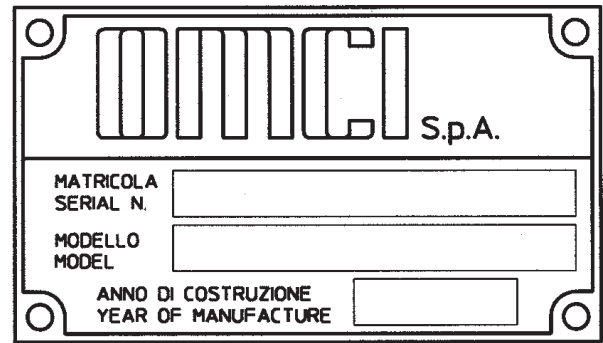

Fig. 1.2

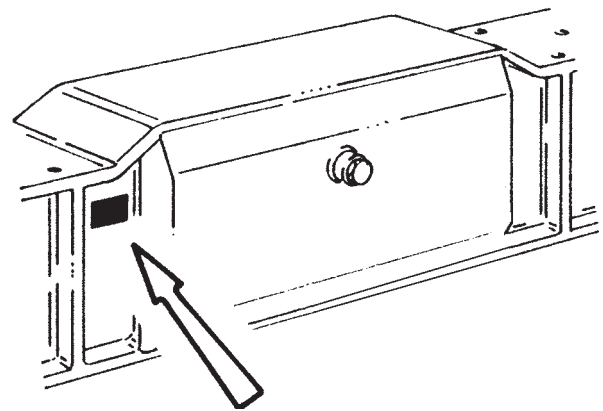

Fig. 1.3



Lift the axle with appropriate means and check the stability. For safety move the axle and its components keeping the load as low as possible. If you use a lift truck the forks must be in the widest position and positioned in the center of axle. Nobody must be near the axle during handling.

### **3 - MAINTENANCE**

- 3.1 - Foreword
- 3.2 - Tests conducted by the Manufacturer
- 3.3 - Routine inspections
- 3.4 - Checking and changing of the oil
- 3.5 - Recommended oils
- 3.6 - Recommended greases
- 3.7 - Greasing points

# 5

## **5 - CLEANING AND INSPECTIONS**

5.1 - Cleaning

5.2 - Bearings

5.3 - Brake disks

5.4 - Seals, oil retaining rings and thrust washer

5.5 - Gears

5.6 - Assemblies

5.7 - Use of thread-locking adhesive (Loctite®) and  
paste seals (silicone)

CLICK HERE TO **DOWNLOAD** THE COMPLETE MANUAL

- Thank you very much for reading the preview of the manual.
- You can download the complete manual from: [www.heydownloads.com](http://www.heydownloads.com) by clicking the link below



- Please note: If there is no response to CLICKING the link, please download this PDF first and then click on it.

CLICK HERE TO **DOWNLOAD** THE COMPLETE MANUAL

### 6.10 - Assembly of the wheel hub gear

- Check that the three planet gears pos.4 fig.6.20 are perfectly clean. Spread their central holes with a film of hard grease. Use grease type FINA MARSON EPL 3, NLGI:3 degree.
- Position the needles pos.3 inside the gears pos.4 so that it's fully filled, placing a spacer ring pos.6 between each row of needles.
- Position the two external thrust washers pos.5 and insert the planet gear into the spider, carefully centering the plug hole. For this purpose use tool OMCI No.2 of chapter 7.
- Having perfectly centered the planet gear, remove the centering tool and mount pin shaft pos.2, taking care to position it so that the milling points towards the circlip pos.1.
- Mount the remaining planetary gears in the same way.
- Having correctly installed the three planet gears and relative pins, position the circlip pos.1 and check if it's correctly installed.
- Apply a continuous thread of silicone to the coupling surface between the wheel hub and the planet spider.
- Mount the axle shaft, inserting it into the central hole of the spindle. Keep it pushed downwards in order to lift the other hand and slightly turn it to center the teeth of the grooved profile. The axle shaft has to enter the hole smoothly and without resistance. If not the case, demount the axle shaft and check for any dents on the grooved profile.
- Apply a drop of Loctite 262 onto the screws pos.1 fig.6.21 and tighten them to specified torque (see chapter 7).
- Fill with oil every part that needs it and lubricate the greasing points. See chapter 3 for further information.  
For quality and quantity see paragraphs 3.5 and 3.6.

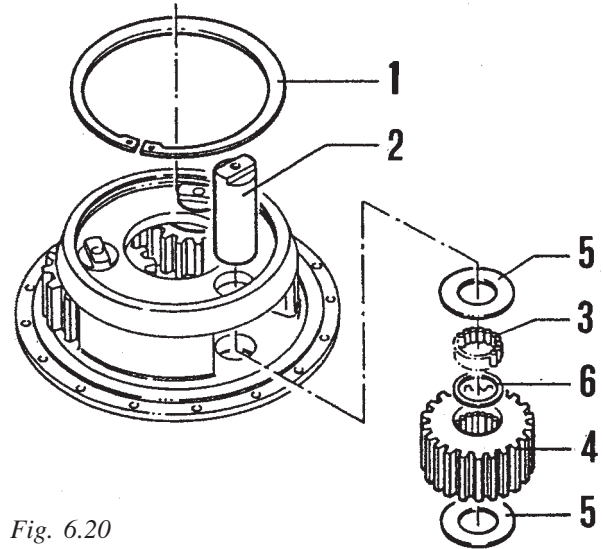

Fig. 6.20

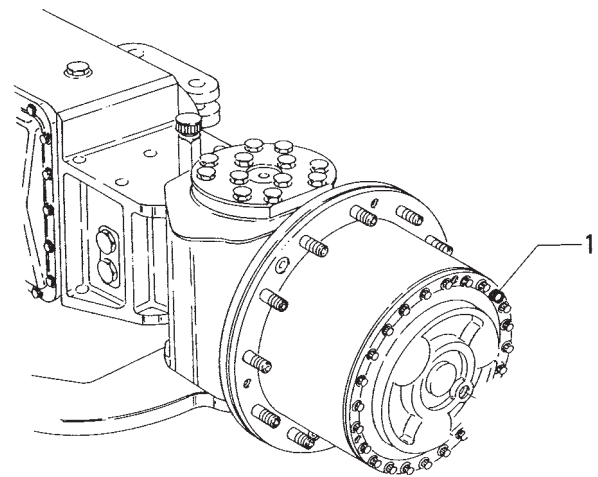
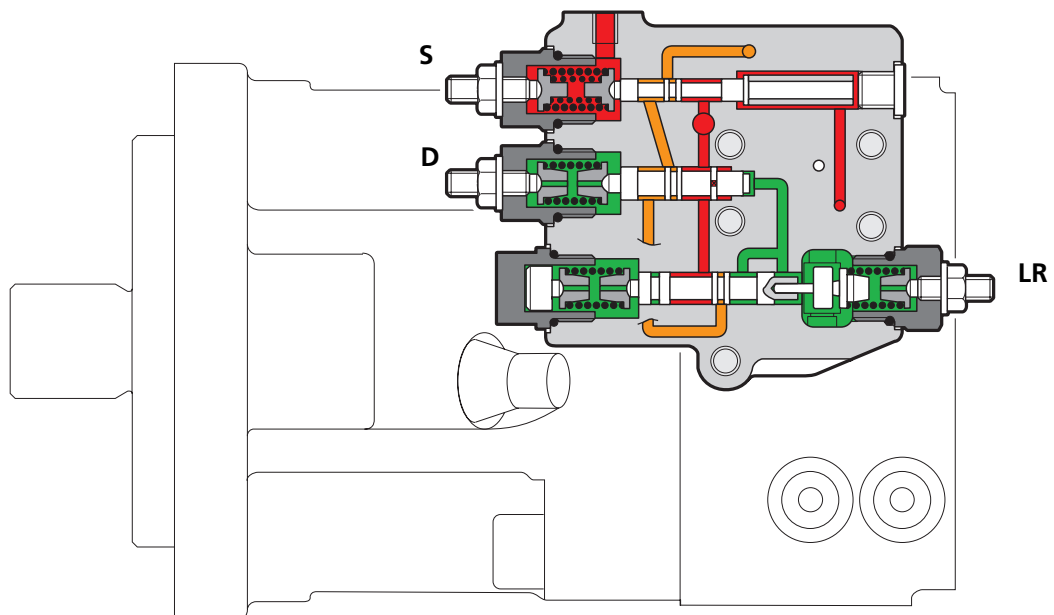
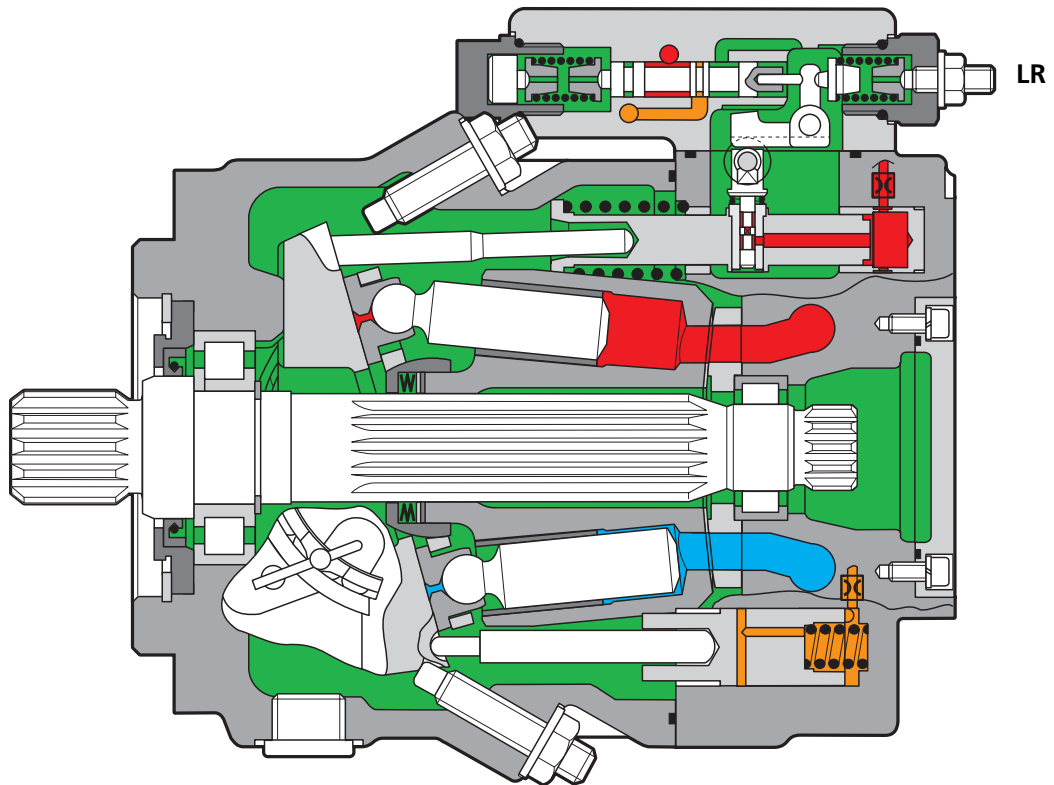

Fig. 6.21

### 6.11 - Assembly of the brake cylinders

For assembly and installation of the brake cylinders see the manual O.M.C.I. cod.031027 CCD.372110.

## A11VO...LRDS



Anschlußplatte, Regler demontieren  
Remove port plate, regulator

Reparaturanleitung A11VO  
Repair Instructions A11VO

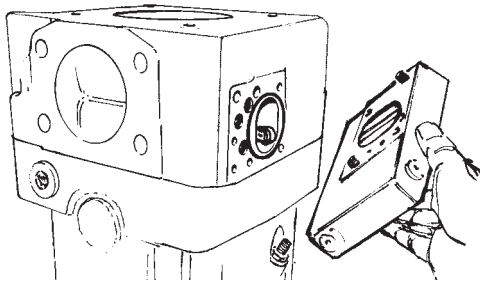

Reglergehäuse abbauen.



Bei Regler mit Meßfeder z.B. DRL, EP, LRDH -  
zuerst Steuerbuchse mit Meßfeder ausbauen,  
dann Reglergehäuse abbauen.

Remove regulator housing.



For control with measuring spring for instance: DRL, EP,  
LRDH - at first remove control bush with measuring spring,  
than remove regulator housing.

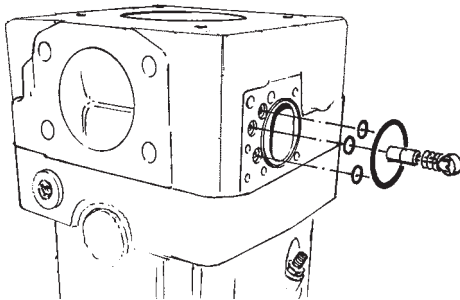

O-Ringe, Meßkolben mit Büchse und  
Feder ausbauen.

Remove O-ring, measuring piston  
with bush and spring.

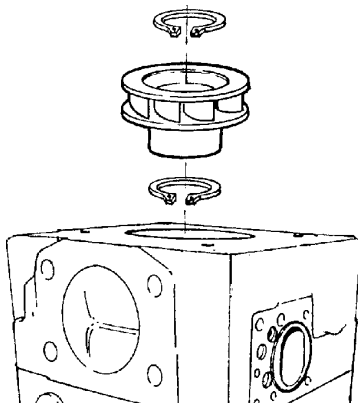

Ausführung mit Impeller!  
Zuerst Impeller ausbauen.



Design with impeller!  
At first remove impeller.

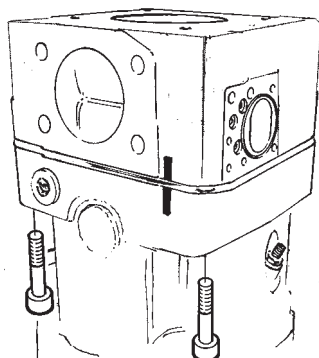

Lage der Anschlußplatte markieren.  
Anschlußplattenbefestigung lösen.

Mark position of the connection plate.  
Loosen connection plate fixation.

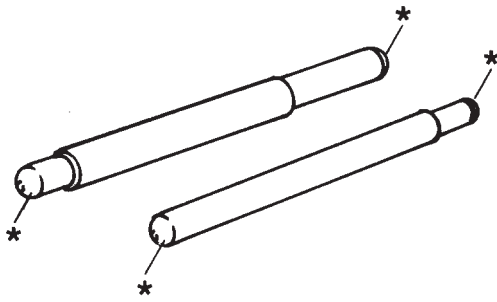

Kontrolle!  
Kugelhöpfe



Geschliffene Seite zur Wiege einbauen!

Inspection!  
Fixing segments



Assemble the grinded side to the cradle!

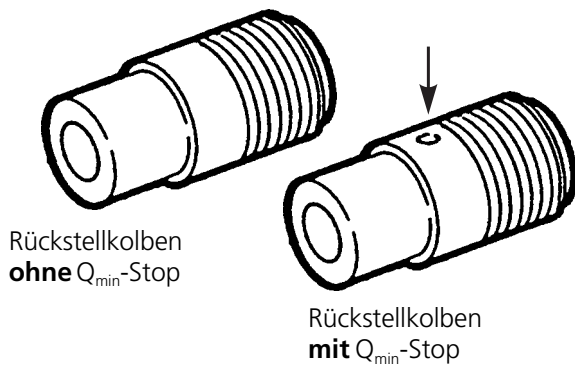

Kontrolle!  
Rückstellkolben (\*)  
Abstimmung über Rückstellstange.



Inspection!  
Piston (\*)  
Adjustment ..

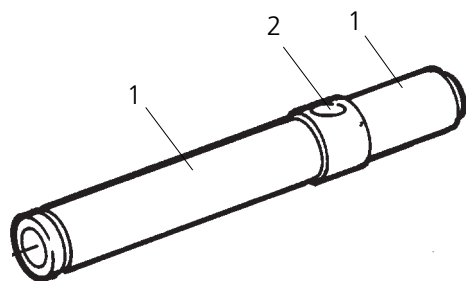

Kontrolle!  
Stellkolben (1),  
Bohrung - Stellbüchse (2).

Inspection!  
Positioning piston (1),  
Boring - control bush (2).

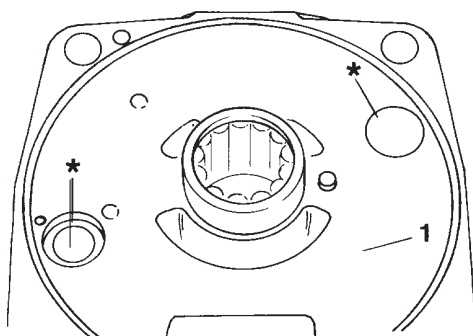

Kontrolle!  
Bohrung (\*),  
Auflagefläche - Steuerplatte (1).

Inspection!  
Boring (\*),  
Contact area control plate (1).

## 1. Vorbereiten Funktionsprüfung

- 1.1 Leistungsdiagramm anfordern
- 1.2 Einbauen, befestigen und Gehäuse füllen
- 1.3 Drehrichtung festlegen

### Anschlüsse / ports

#### A11VO 40 ... 130 LRDS

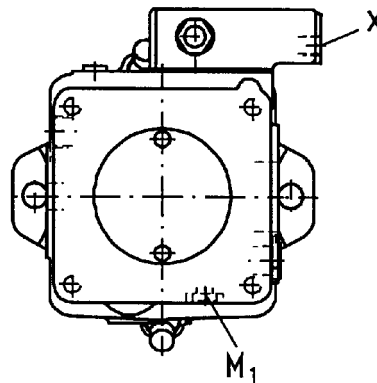
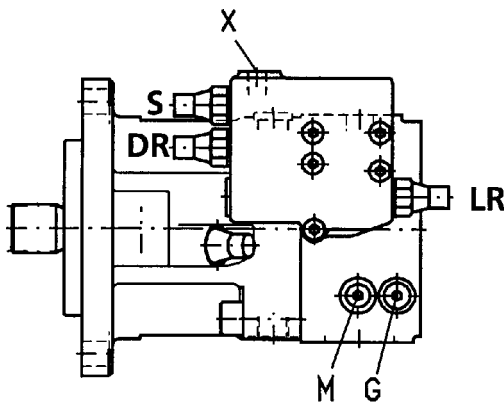

- M:** Meßstelle, Arbeitsanschluß /  
Test ports, pressure port
- M<sub>1</sub>:** Meßstelle, Stellkammer /  
Test port
- LR:** Leistungsregler /  
HP-control
- DR:** Druckabschneidung /  
Pressure cut-off
- X:** Anschluß für  $\Delta P$ -Regler /  
Port for  $\Delta P$ -control
- G:** Anschluß für Stelldruck /  
Port for positioning pressure
- S:** Load-Sensing-regler /  
Load-sensing control

#### A11VO 40 ... 130 LRDH

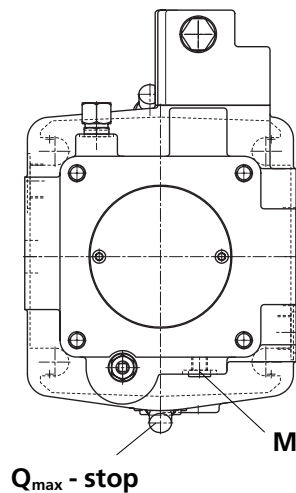
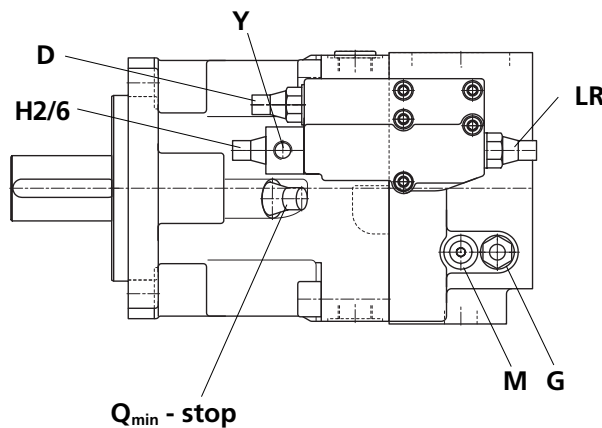

- M:** Meßstelle, Arbeitsanschluß  
Test point, pressure port
- M<sub>1</sub>:** Meßstelle, Stellkammer  
Test point, adjustment  
chamber
- G:** Anschluß für Stelldruck  
Port for adjustment pressure
- LR:** Leistungsregler  
HP-control
- D:** Druckabschneidung  
Pressure cut-off
- H2/6:** Hydraulische Hubbe-  
grenzung  $V_{g \min} - V_{g \max}$   
Hydraulic stroke limiter

## 2. Einstellvorgang

- 2.1 Auf Prüftemperatur fahren
- 2.2 Antriebsdrehzahl
- 2.3  $Q_{\min}$ -Anschlag ausschrauben

## 2. Setting process

- 2.1 Drive to temperature
- 2.2 Input speed
- 2.3 Screw-out  $Q_{\min}$ -stop

**D****2.13 Einstellen Druckregler**

2.14 Mit Belastungsventil Druckregler nach Leistungsdiagramm einstellen.

## Beispiel 4

Druckreglereinstellung = 310 bar  
Betriebsdruck mit Belastungsventil auf ~ 350 bar erhöhen.

Blockierten Druckregler vorsichtig herausdrehen bis 310 bar erreicht wird.  
Einstellschraube kontern.

## Example 4

Setting of constant pressure control = 310 bar  
Increase operation pressure with help of charge valve ~ to 350 bar.

Unscrew carefully blocked constant pressure control up to 310 bar.  
Jam setting screw.

**2.13 Setting of constant pressure**

2.14 Setting with help of the charge valve the constant pressure control as to HP diagram.

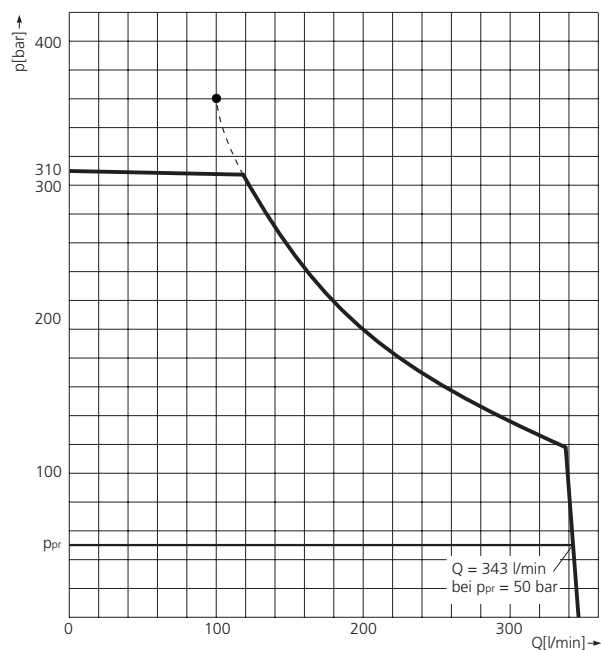

I30	9 Stop pressure switch	M7	15 Front windscreen washer pump	R36	14 4 inputs and 4 outputs circuit
I31	11 Back-up lights switch	M8	15 Rear wiper motor	S1	20 1200 rpm solenoid valve
I32	21 Emergency pump switch	M9	13 Rear aeration solenoid valve	S2	8 Forward movement solenoid valve
I33	17 Manoeuvres manipulator	M10	13 Air conditioner compressor	S3	8 Reverse solenoid valve
I34	10 Levelling switch	M11	13 Cab aeration fan motor	S4	10 LH levelling solenoid valve
I38	11 Air filter pressure switch	M13	21 Pneumatic seat	S5	9 Anti-tilting solenoid valve
IP	6 Ceiling light switch	M14	15 Top wiper motor	S6	10 RH levelling solenoid valve
L1	11 Battery optical indicator	P3	7 Identification plate light	S7	9 Fast movement solenoid valve
L2	11 Turn indicators optical indicator	P17	6 Cab light	S8	9 Slow movement solenoid valve
L3	11 Position lights optical indicator	PPA	10 Provision for front axle alignment	S9	5 Differential block solenoid valve
L4	11 High beam lights optical indicator	PPP	10 Provision for rear axle alignment	S10	17 Boom extension solenoid valve
L5	11 Low beam lights optical indicator		proximity switch	S11	17 Boom retract solenoid valve
L6	11 Air filter clogged optical indicator	R1a	4 Start-up enable relay	S12	18 Optional 1 solenoid valve
L7	11 Oil pressure optical indicator	R1b	19 Work lights power supply relay	S13	18 Optional 2 solenoid valve
L8	11 Oil level optical indicator	R2b	19 Forward movement relay	S14	15 Crab steering solenoid valve
L9	11 Water temperature optical indicator	R3a	8 Reverse relay	S15	15 Concentric steering solenoid
L10	11 Control unit fault optical indicator	R4a	4 Machine locked with key power	S16	17 Optional double solenoid valve
L11	11 Parking brake optical indicator	R4b	4 Machine locked with key power	S19	21 Mixer bucket solenoid valve
L12	11 Brakes oil level optical indicator		supply relay	S20	17 Optional triple solenoid valve
L13	9 Slow speed optical indicator	R5a	7 Low beam lights relay	ST1	12 Hour meter and rev counter
L14	9 Fast speed optical indicator	R5b	14 Oil cooling fan relay	ST2	12 Water temperature instrument
L15	15 Crab steering optical indicator	R6a	7 High beam lights relay	ST3	12 Fuel level instrument
L16	15 Concentric steering optical indicator	R6b	14 Oil cooling fan relay	ST4	9 Anti-tilting control unit
L17	17 Boom top second outlet optical indicator	R7a	11 Parking optical indicator relay	ST5	9 Load cell
L18	17 Control unit fault indicator	R7b	14 Oil cooling fan relay	ST6	9 Load cell
L19	18 Control unit fault indicator	R8a	20 1200 rpm solenoid valve relay	ST7	9 Anti-tilting control unit
L20	9 Anti-tilting exclusion optical indicator	R8b	10 Levelling relay	T1	19 Float
L20b	9 Anti-tilting exclusion optical indicator	R9a	9 Anti-tilting relay	TR	21 Thermo-starter
L21	17 Boom top 3 <sup>rd</sup> outlet optical indicator	R9b	5 Differential block relay	X2	16 Mercedes adm control unit
L22	15 Normal steering optical indicator	R10a	6 Relay intermittence relay	X17	16 Diagnostics connector
M1	4 Starter motor	R10b	5 Horn relay	X21/A	17 RC2-2/20 Rexroth 1 <sup>st</sup> control unit
M2	14 Hydraulic oil cooling fan	R11b	5 Buzzer and reversal lights relay	X21/B	18 RC2-2/20 Rexroth 2 <sup>nd</sup> control unit
M3	14 Hydraulic oil cooling fan	R12a	5 Brake lights relay	X30	16 Mercedes motor control unit
M4	14 Hydraulic oil cooling fan	R12b	14 Oil cooling relay	X31	16 Accelerator pedal connector
M5	14 Hydraulic oil cooling fan	R13	6 Intermittence	X35	20 Antitheft connector
M6	15 Front wiper motor	R14a	21 Air heater relay	X36	20 Car radio connector
		R16b	8 Starter motor relay	X61	21 Basket connector
		R33	9 Slow-fast bistatic relay		
		R34	17 Optional double relay		
		R35	17 Boom top outputs set-reset relay		

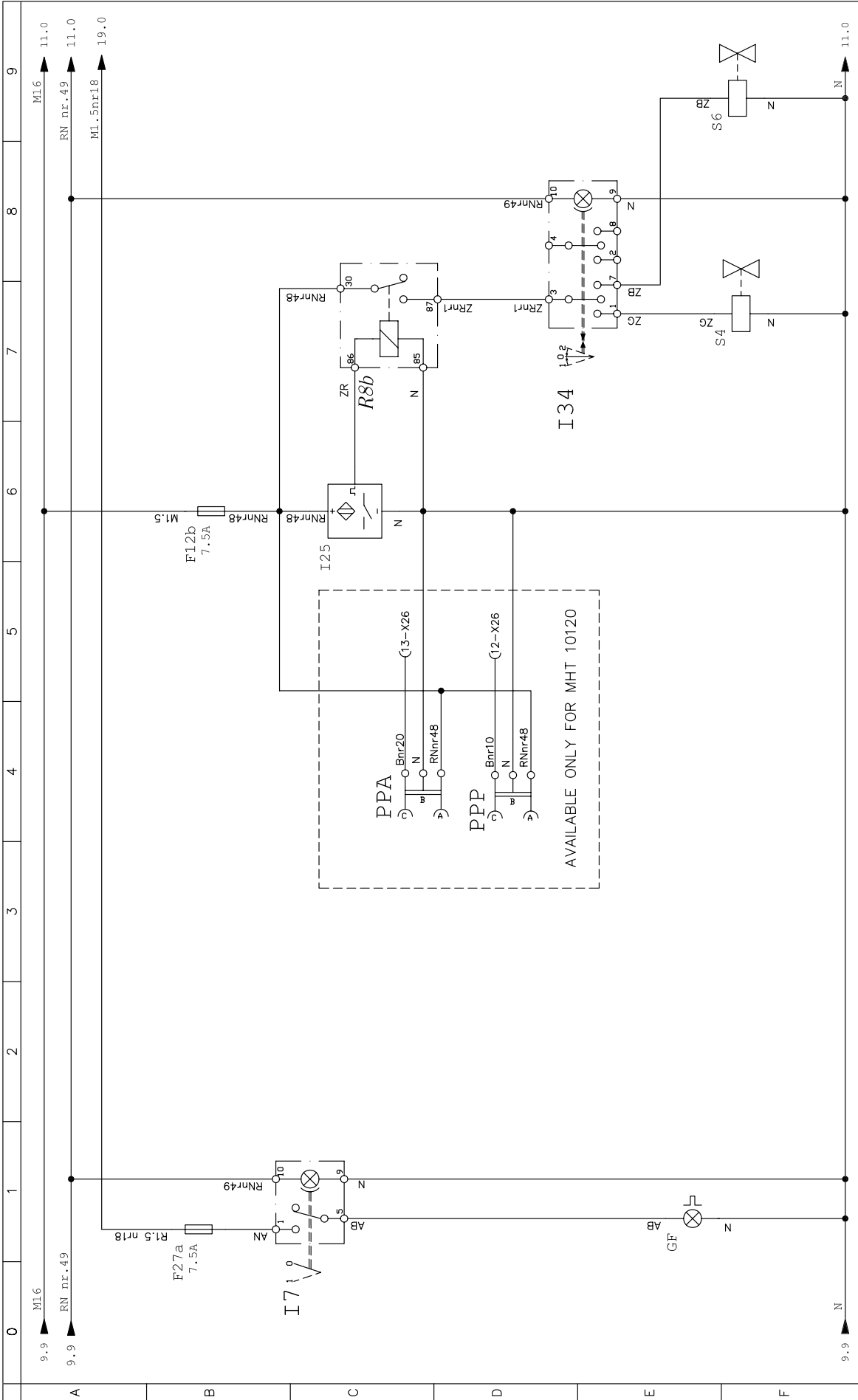

**TAVOLA  
TABLE  
10**

MHT 990-7140-10160 M SERIES DISTRIBUTORE REXROTH (09-2003) / MHT 990-7140-10160 M SERIES DISTRIBUTOR REXROTH (09-2003)  
**MANIP. LIVELLAMENTO E LAMPADA ROTANTE**  
**LEVELLING AND WORKING LAMP**



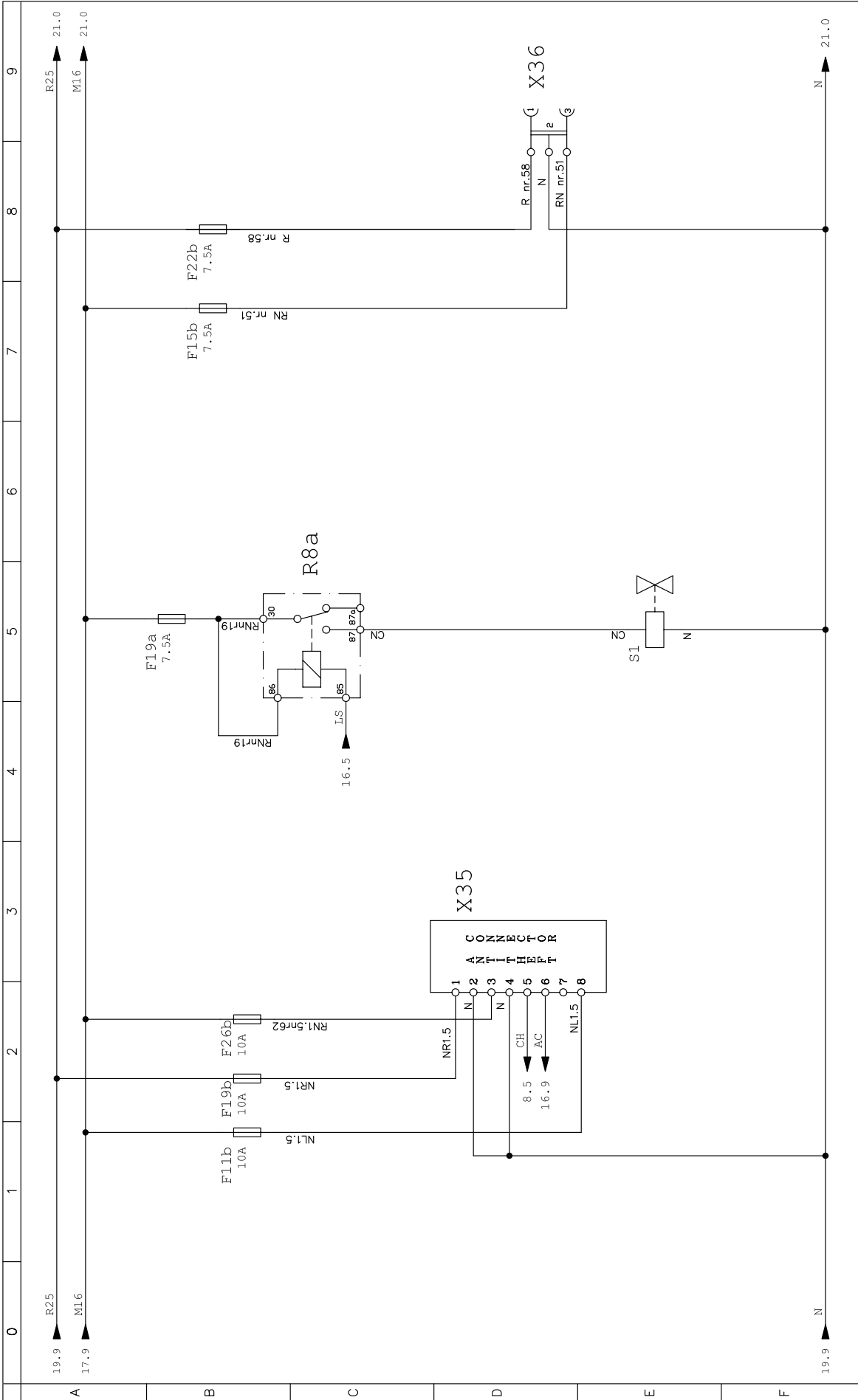

**TAVOLA  
TABLE  
20**

MHT 990-7140-10160 M SERIES DISTRIBUTORE REXROTH (09-2003) / MHT 990-7140-10160 M SERIES DISTRIBUTOR REXROTH (09-2003)

**ANTIFURTO, AUTORADIO  
ANTI-THIEF, RADIO**

**MANITOU**

Denominazione  
Name:

CLICK HERE TO **DOWNLOAD** THE COMPLETE MANUAL

- Thank you very much for reading the preview of the manual.
- You can download the complete manual from: [www.heydownloads.com](http://www.heydownloads.com) by clicking the link below



- Please note: If there is no response to CLICKING the link, please download this PDF first and then click on it.

CLICK HERE TO **DOWNLOAD** THE COMPLETE MANUAL