



GEHL

ALT 950 145 V PLUS D ST5 S1

Telescopic Articulated Loader
Repair Manual

647926 Rev. C 11/20

Original Instructions

CLICK HERE TO **DOWNLOAD** THE COMPLETE MANUAL

- Thank you very much for reading the preview of the manual.
- You can download the complete manual from: www.heydownloads.com by clicking the link below



- Please note: If there is no response to CLICKING the link, please download this PDF first and then click on it.

CLICK HERE TO **DOWNLOAD** THE COMPLETE MANUAL



⚠ WARNING

Never step on a part of the machine that has not been designed for it.



⚠ WARNING

Never wear clothes, jewelry or objects that could get caught during work and cause accidents.

Always wear protection glasses, gloves, safety shoes as well as any other protection required for the work to be carried out.

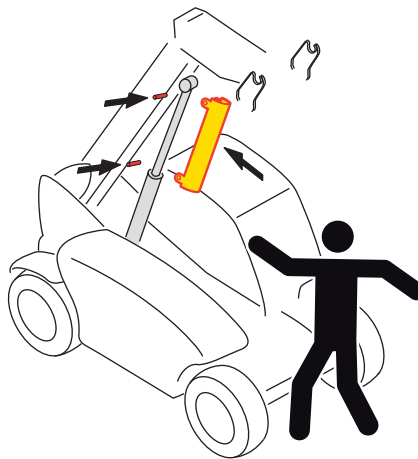
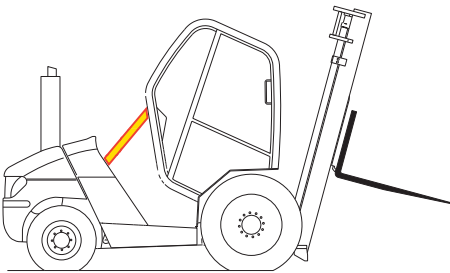

⚠ DANGER

When carrying out maintenance operations near a mobile object, make sure it is securitized.



♻ PROTÉGER L'ENVIRONNEMENT

When changing, or draining oils or fuel, or any other operation with liquids, solids, gases that are harmful to the environment, make sure the necessary precautions are taken to avoid contaminating the environment.

00.4.3 FILTER ELEMENTS AND BELTS

DESCRIPTION	REFERENCE	500 H (WITHIN 6 MONTHS) (1° SERVICE)	PERIODIC REPLACEMENTS
1 Air filter cartridge	299936	Replace	Every 500 hours
2 Transmission oil filter	52587189	-	-
3 Hydraulic oil filter cartridge (exhaust)	53023374	Replace	Every 1000 hours
4 Hydraulic oil filter cartridge (intake)	924767	Replace	Every 500 hours
5 Hydraulic oil filter cartridge (intake)	928872	Replace	Every 500 hours
6 Safety air filter cartridge	299937	Replace	Every 1000 hours
7 Fuel tank plug	925780	Replace	Every 1000 hours
8 Fuel tank plug	925786	-	-
9 Hydraulic oil tank plug	53011245	-	-
10 Hydraulic oil tank plug	52573814	-	-
11 Air filter cartridge internal for cab	53023826	Replace	Every 1000 hours
12 Air filter cartridge external for cab	53023827	Replace	Every 1000 hours
13 Hydraulic oil tank vent	278288	-	-
14 DEF tank vent	943253	-	-
15 DEF tank plug	943254	-	-
16 DEF tank plug	943255	-	-
17 DEF tank plug	943252	-	-
18 Pump diesel exhaust fluid filter	942244	-	-
19 KIT 500h	52587811	-	-
20 KIT 1000h	52587862	-	-
21 Engine oil filter	52587875	Replace	Every 500 hours
22 Fuel pre-filter cartridge	52587874	Clean	-
23 Fuel filter cartridge	52587871	Replace	Every 500 hours
24 Engine belt	52587877	Replace	Every 3000 hours
25 Air conditioning belt	52587879	Replace	Every 3000 hours

reoccurs within a period of 40 operating hours, the counters will continue with the frozen value. If derating step 2 was already active when the error was healed, it will become active again after 2h for Quality or 5h for Tampering. The inducement level 2h or 5h before severe inducement becomes active.

10.2.4 SCR-SYSTEM (EU)

DEF-Level Monitoring (EU)

If no DEF additive is available in the DEF tank, the emission requirements cannot be fulfilled and therefore an inducement must be activated.

Three error messages are available representing the monitoring steps with active engine limitations.

⚠ CAUTION
<i>The override of the errors which belong to the "Level" is possible considering above mentioned limitations.</i>

DEF level monitoring escalation steps:

Level	Level indicator	DEF Lamp (flashing speed)	Warning Lamp (behavior)	Buzzer	System Reaction (EU)
		Symbol	Symbol		Operator Actions
>15%		-	-		-
		-	-		-
<15%		(solid on)	-		-
		Level < 15%	-		fill the def tank
<10%		(slow)	-		-
		Level < 10%	-		fill the def tank
<5%		(flashing)	(solid on)		-
		restriction			refill the def tank
10 min after level < 5%		(medium)	(solid on)		derating step 1 active
		restriction			carry out the override + refill the def tank
15 min after level < 5%		(fast)	(blinking)		derating step 1 active
		restriction			carry out the override + refill the def tank
20 min after level < 5%		(fast)	(blinking)		derating step 2 active
		restriction			call for service.

The machine is fully restored to normal functionality and operation when a tank fill is performed and indicated. A tank fill is assumed when the level exceeds the Reduction level 1 trigger level. If the filled DEF level does not exceed the initial warning level (<10%), the operator warning system remains active.

10.2.7 DPF-SYSTEM (EPA)

The DPF system is a closed soot filter system that accumulates the soot load during operation time of the machine. The filter regeneration is a continuous process (CRT) starting as soon as the necessary conditions at the inlet of the system are reached. These conditions are mainly exhaust temperatures and NOx / Soot-ratio.















The filter load is permanently monitored.

If the regeneration process is not possible for any reason the system triggers additional actions to start the regeneration.

An operator response is required only if these actions are not successful.

⚠ CAUTION
<i>For the warnings based on DPF soot load, it's generally no override possible!</i>

DPF Regeneration strategy:

DPF Regeneration strategy		Description	Standstill Lamp (flashing speed)	Warning Lamp (behavior)	Buzzer	System Reaction (EPA)
Soot level			Symbol	Symbol		Operator Actions
0	Normal operation	No need for regeneration	-	-		no derating
			-	-		-
1	Heat Mode 1 requested	Heat Mode 1 requested	-	-		no derating
			-	-		-
2	Heat Mode 2 requested	Heat Mode 2 requested	-	-		no derating
			-	-		-
3	Standstill required	Standstill required	(slow)	-		no derating
				-		carry out the DPF regeneration
4	Warning Level	Standstill required	(slow)	(solid on)		derating step 1 active
						carry out the DPF regeneration (if necessary) + override
5	Shut Off Level	Service Tool required for standstill	(very fast)	(blinking)		derating step 2 active
						carry out the override + call for service
6	Remove Filter	DPF removal required. No standstill allowed	(very fast)	(blinking)		derating step 2 active
						carry out the override + call for service

⚠ CAUTION
<i>For the warnings based on DPF soot load, it's generally no override possible!</i>

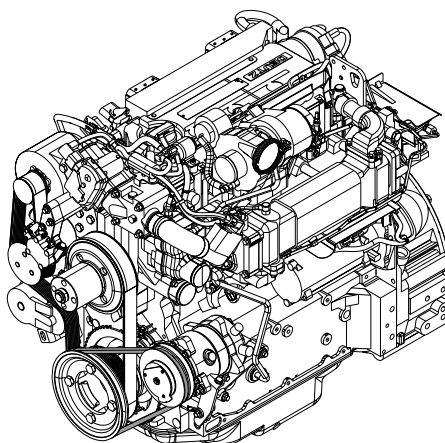

E - REMOVAL A/C BELT (OPTION)

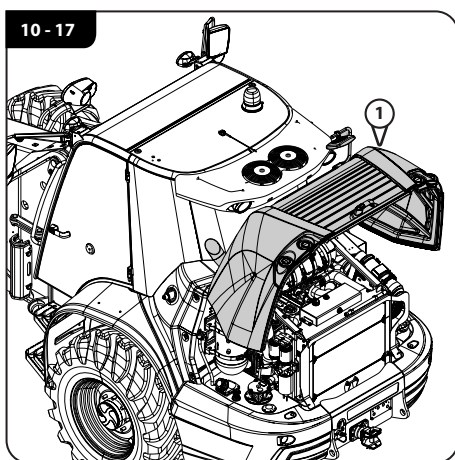

Open the hood (1,  10-17).

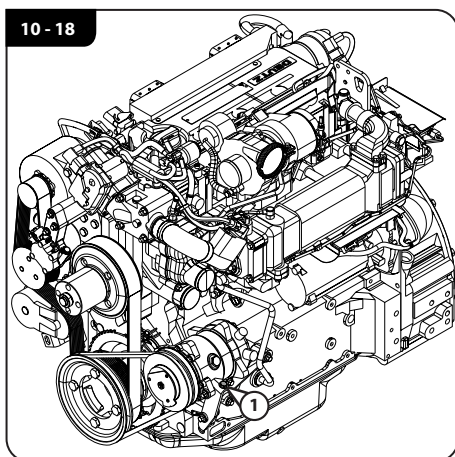

Slacken the compressor tensioning belt screws (1,  10-18).

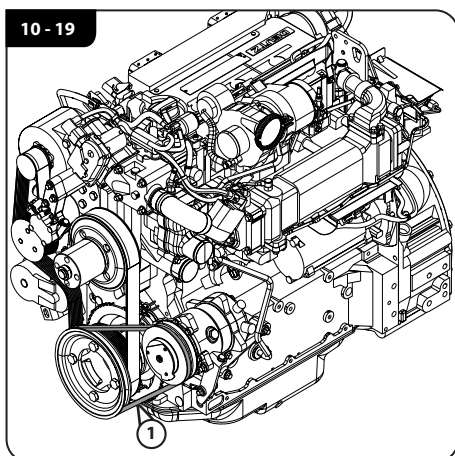

Remove the A/C belt (1,  10-19).

10.6 REMOVING DEF (DIESEL EXHAUST FLUID) CIRCUIT

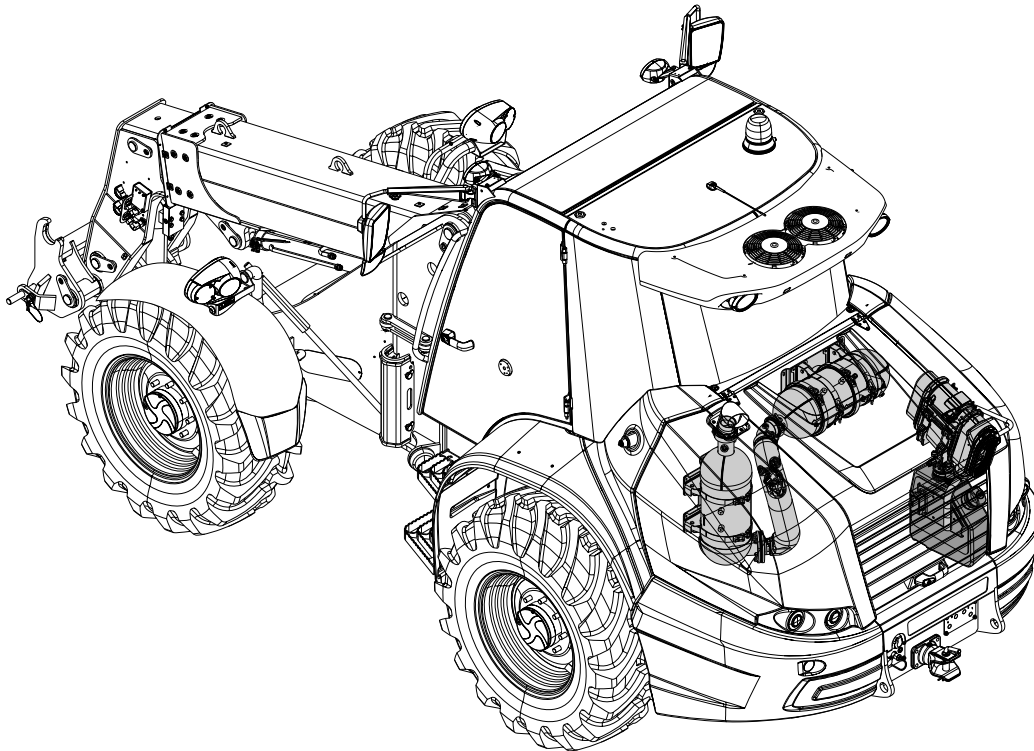

GENERAL INFORMATION

Mark all the hydraulic pipes and electrical connections with a marker pen, before disassembling, to ensure correct positioning in the reassembly phase.

WARNING

Plug all the hydraulic pipes and orifices to prevent impurities from contaminating the hydraulic circuit.

PREPARATION AND SAFETY INSTRUCTIONS

- Stabilize the machine on level ground.
- Drive the machine in forward and reverse several times (wheels straight) in order to relieve any strain on the steering and tires.
- Raise the boom to mid-height and secure it using the lifting cylinder rod locking wedge.
- Deactivate battery power supply by means of the battery cut-off.

WARNING

Operate the battery cut-off no less than 30 seconds after turning off the ignition with the ignition key.

SPECIFIC TOOLING

- Stacker or pallet truck.
- Hydraulic jack + blocks.
- Floor crane or hoist + slings (1000 kg min.).

10.8 ENGINE TROUBLESHOOTING

Engine error codes (↪ **80.4 ELECTRICAL TROUBLESHOOTING**).

Remarks: There will be no synchronisation of ECUs and the machine will not be operational if the screen is disconnected, or if there is a malfunction, or if the ECU software versions are different.
The engine will start and stop after 15 s.

10.9 SPECIFIC ENGINE TOOLING

10.9.1 SPECIAL ENGINE TOOLING

 MR 647549 Special Tools "W 49-01-01".

10.9.2 ELECTRONIC TENSION METER



Electronic tension meter (P/N 895692) for checking belt tension.

20.4 PRESSURE TAKE-OFF POINTS

20.4.1 A4VXG 90 DA SERIES 32 PUMP

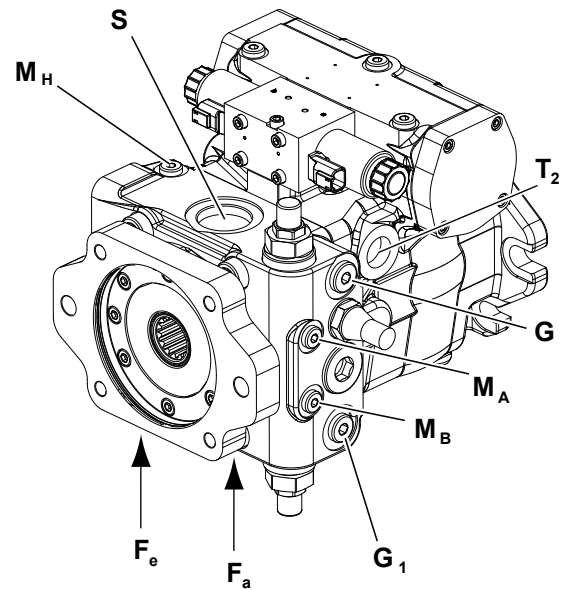
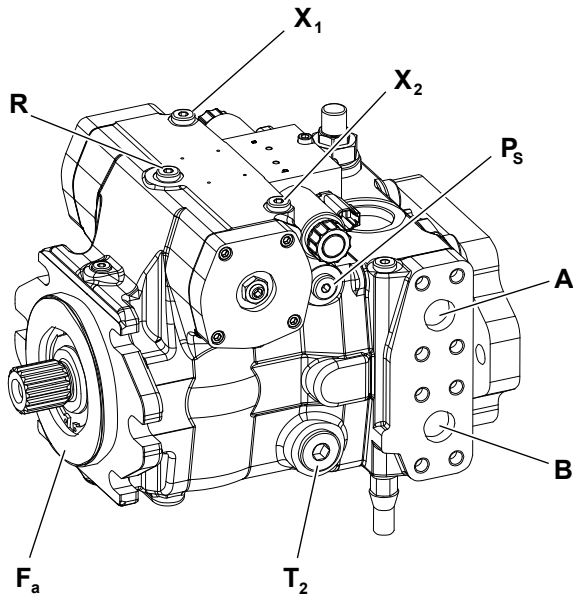

Port	Designation
A , B	Service line
T1	Tank
T2	Tank
X1 , X2	Control pressure (upstream of orifice)
MA , MB	Measuring pressure A, B
G	Boost pressure
PS	Pilot pressure inlet
R	Air bleed
S	Suction
MH	Measuring high pressure
Fa	Boost pressure inlet
Fe	Boost pressure outlet
G1	Pressure port for auxiliary circuit

20.6.6 TROUBLE-SHOOTING

PUMP/MOTOR

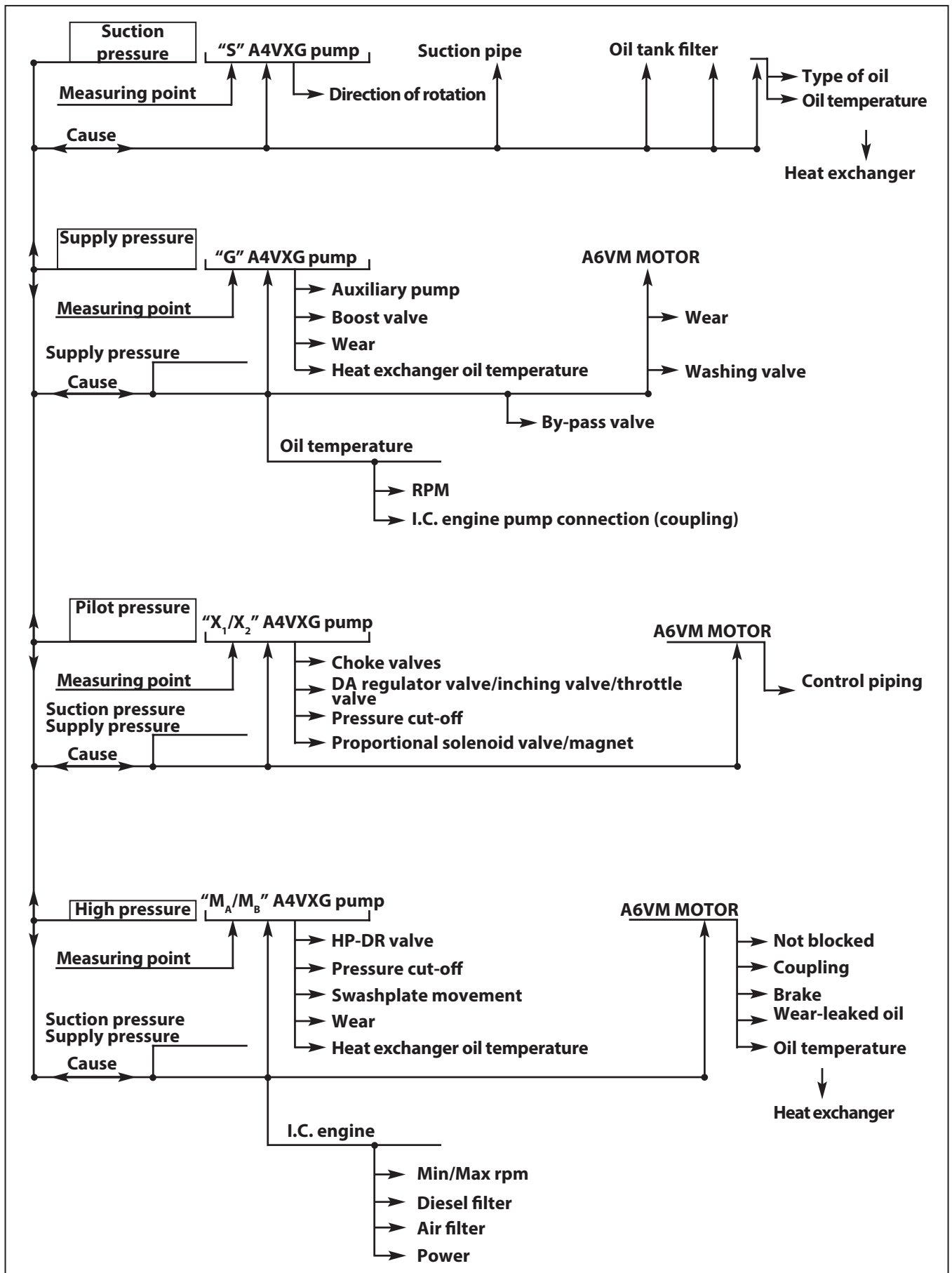

SPN / FMI	SPN / FMI	DTC	Fault / Description	Possible Cause	Reaction	Quit	Save	Debounce time [ms]	Remedy	Note
8034	32820	7F034	Hydmot 1 Safe Output	Smaller motor 1 solenoid faulty	Ramp down --> Machine moves at limited velocity in both direction. Gearbox is locked.	Restart drive controller.	YES	200	Check the wiring pin: 178,185	
FMI = 4, VOLTAGE BELOW NORMAL, OR SHORTED TO LOW SOURCE	4	4	safout_getStatus()							Never occurs
FMI = 5, CURRENT BELOW NORMAL OR OPEN CIRCUIT	5	5	safout_getStatus()	The error occurs during initialization.						
FMI = 6, CURRENT ABOVE NORMAL OR GROUNDED CIRCUIT	6	6	safout_getStatus()							Never occurs
FMI = 11, ROOT CAUSE NOT KNOWN	11	B	safout_getStatus()	The error occurs if initialization is done.						
8035	32821	7F035	Hydmot 2 Safe Output	Bigger motor 2 solenoid faulty	Ramp down to velocity limited --> Machine moves at limited velocity in both direction. Gearbox is locked.	Restart drive controller.	YES	200	Check the wiring pin: 175,186	
FMI = 4, VOLTAGE BELOW NORMAL, OR SHORTED TO LOW SOURCE	4	4	safout_getStatus()							Never occurs
FMI = 5, CURRENT BELOW NORMAL OR OPEN CIRCUIT	5	5	safout_getStatus()	The error occurs during initialization.						
FMI = 6, CURRENT ABOVE NORMAL OR GROUNDED CIRCUIT	6	6	safout_getStatus()							Never occurs
FMI = 11, ROOT CAUSE NOT KNOWN	11	B	safout_getStatus()	The error occurs if initialization is done.						
8036	32822	7F036	Gbx Clutch Output	Gear box clutch solenoid faulty	Ramp down to velocity limited --> Machine moves at limited velocity in both direction. Gearbox is locked.	Restart drive controller.	YES	200	Check the wiring pin: 154	
FMI = 3, VOLTAGE ABOVE NORMAL, OR SHORTED TO HIGH SOURCE	3	3	out_getStatus()							Never occurs
FMI = 4, VOLTAGE BELOW NORMAL, OR SHORTED TO LOW SOURCE	4	4	out_getStatus()							Never occurs
FMI = 5, CURRENT BELOW NORMAL OR OPEN CIRCUIT	5	5	out_getStatus()	The error occurs during initialization.						
FMI = 6, CURRENT ABOVE NORMAL OR GROUNDED CIRCUIT	6	6	out_getStatus()							Never occurs
FMI = 11, ROOT CAUSE NOT KNOWN	11	B	out_getStatus()							Never occurs
FMI = 13, OUT OF CALIBRATION	13	D	out_getStatus()							Never occurs
FMI = 31, CONDITION EXISTS	31	1F	out_getStatus()	The error occurs if initialization is done.						
8037	32823	7F037	Pump Imp. Safe Output	Pump implement solenoid faulty	LLC implement pump doesn't work, No influence on the machine traction	Restart drive controller.	YES	200	Check the wiring pin: 151,179	
FMI = 4, VOLTAGE BELOW NORMAL, OR SHORTED TO LOW SOURCE	4	4	safout_getStatus()							Never occurs
FMI = 5, CURRENT BELOW NORMAL OR OPEN CIRCUIT	5	5	safout_getStatus()	The error occurs during initialization.						
FMI = 6, CURRENT ABOVE NORMAL OR GROUNDED CIRCUIT	6	6	safout_getStatus()							Never occurs
FMI = 11, ROOT CAUSE NOT KNOWN	11	B	safout_getStatus()	The error occurs if initialization is done.						
8038			res_56							

Remove the RH vibration damper support (1,  20 - 10).

With the help of the overhead crane, slightly raise the cab.

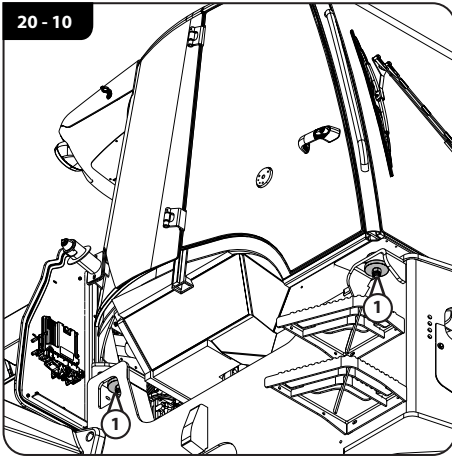

Place the cabin on the appropriate blocks (1,  20 - 11).

Mount the blocks on the frame without tightening the nuts. Fit the cab and finally tighten the nuts.

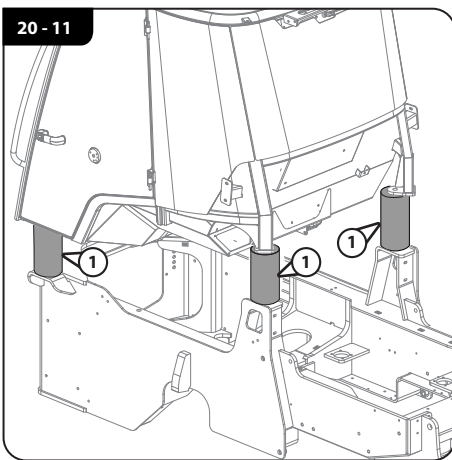

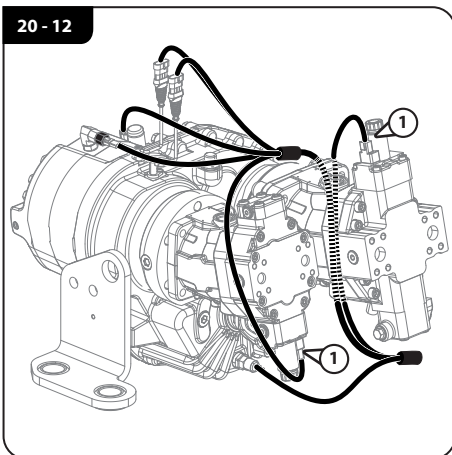

⇒ Carry out the "UNIVERSAL SHAFT REMOVAL" operation  20.7.1

Disconnect the electric connectors (1,  20 - 12) from the hydraulic motors.



Place containers of suitable size to hold the quantity of liquid to be collected under the hydraulic fluid tank drainage cap. Remove the cap and let the oil flow out.

Slacken the screws from the brackets (1,  20 - 13) and remove the tubes (2,  20 - 13) from the hydraulic motors.

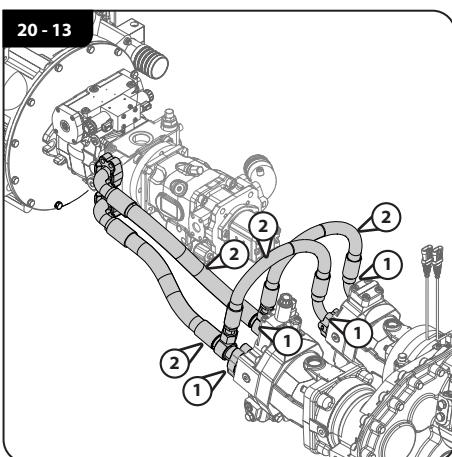

30.1 REMOVING THE AXLE

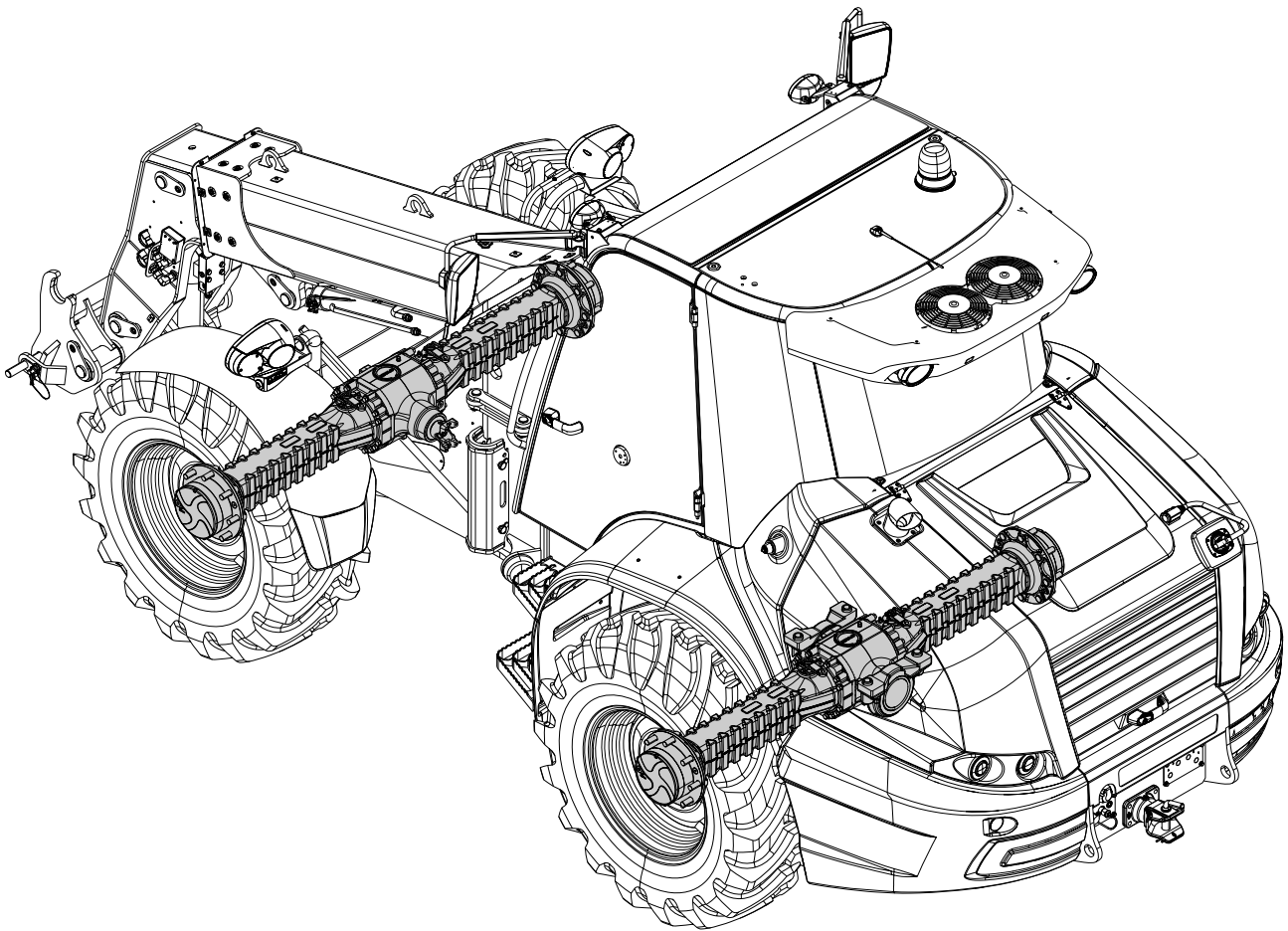

GENERAL INFORMATION

The sequence for disassembly operations must be followed to access the various components.

Mark all the hydraulic pipes and electrical connections with a marker pen, before disassembling, to ensure correct positioning in the reassembly phase.

WARNING

Plug all the hydraulic pipes and orifices to prevent impurities from contaminating the hydraulic circuit.

PREPARATION AND SAFETY INSTRUCTIONS

Park the vehicle on horizontal ground and level it (chassis parallel to front axle).

Lift the machine and place it on the appropriate supports to ensure utmost stability and safety, bringing them to a height necessary to remove the wheels and switch off the I.C. engine.

Specific tools:

- Crane for lifting (5000 kg. minimum).

40.3 BRAKES SYSTEM LAYOUT

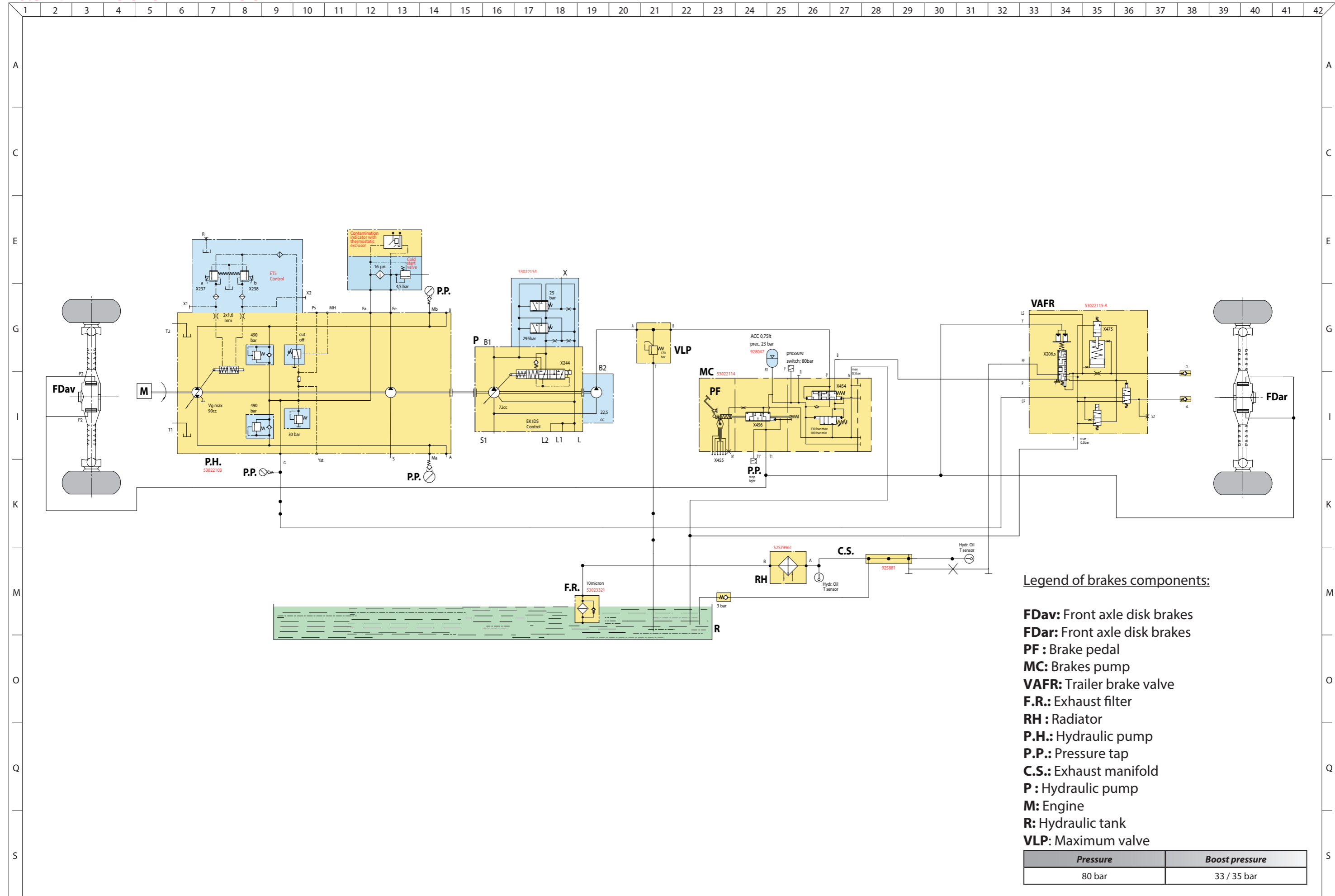

Legend of brakes components:

- FDav:** Front axle disk brakes
- FDar:** Front axle disk brakes
- PF :** Brake pedal
- MC:** Brakes pump
- VAFR:** Trailer brake valve
- F.R.:** Exhaust filter
- RH :** Radiator
- P.H.:** Hydraulic pump
- P.P.:** Pressure tap
- C.S.:** Exhaust manifold
- P :** Hydraulic pump
- M:** Engine
- R:** Hydraulic tank
- VLP:** Maximum valve

Pressure	Boost pressure
80 bar	33 / 35 bar

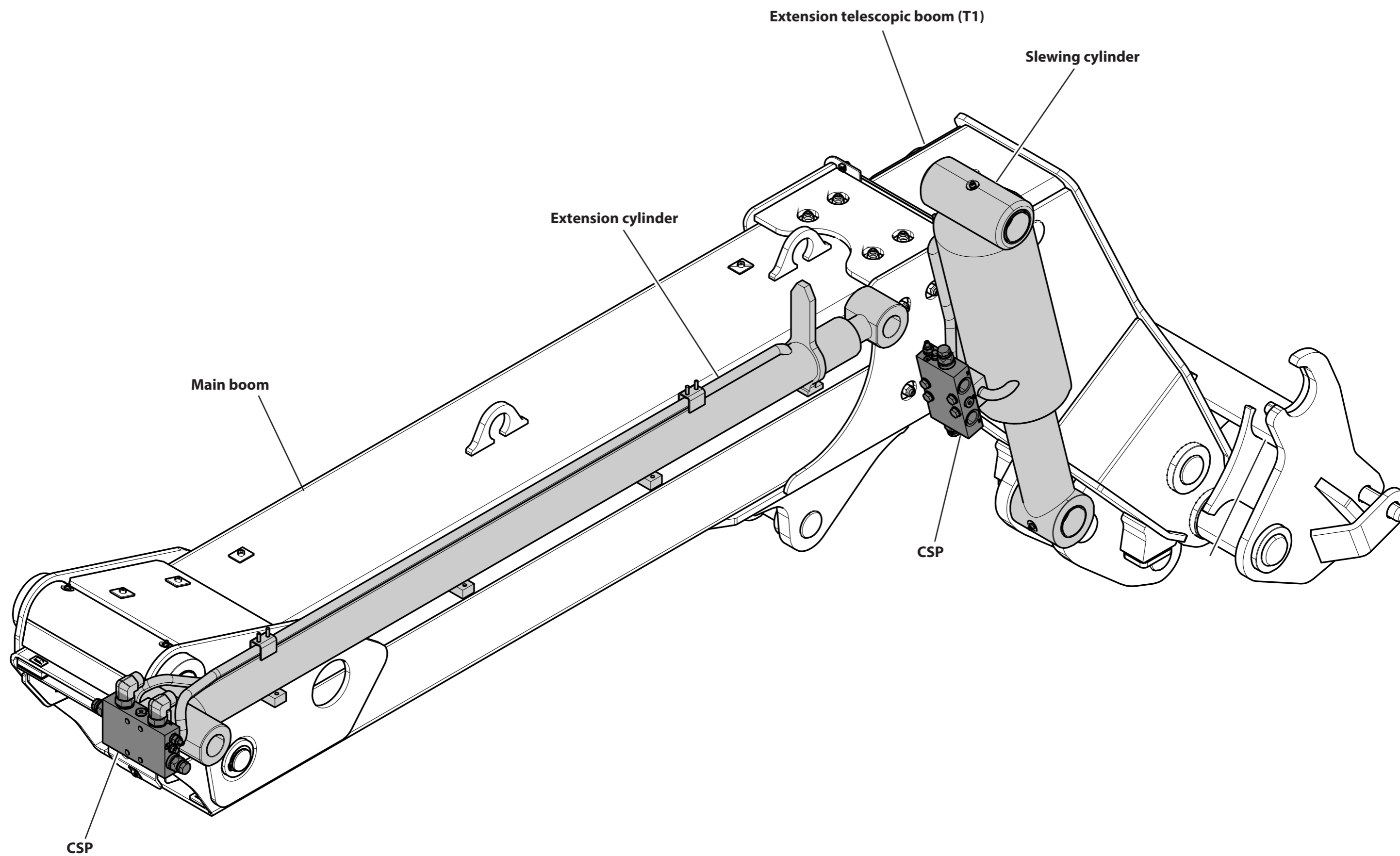

50.2 BOOM COMPONENTS LOCATION

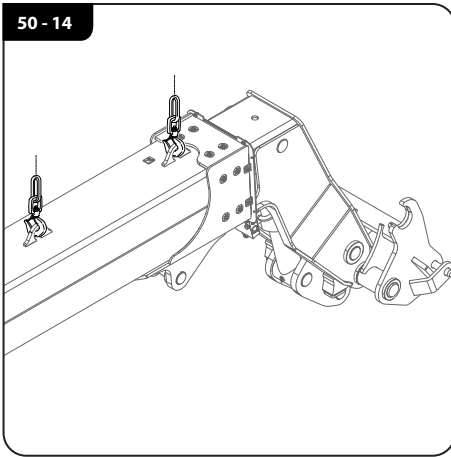



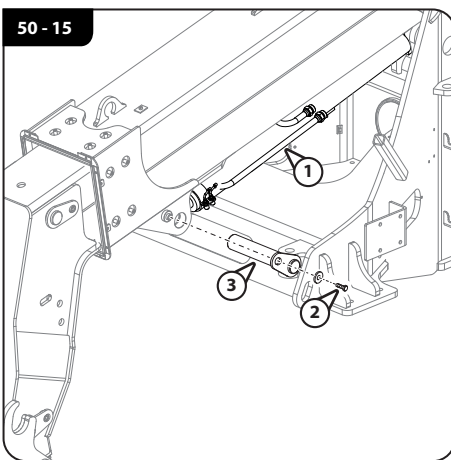

Secure the boom to suitable lifting means.

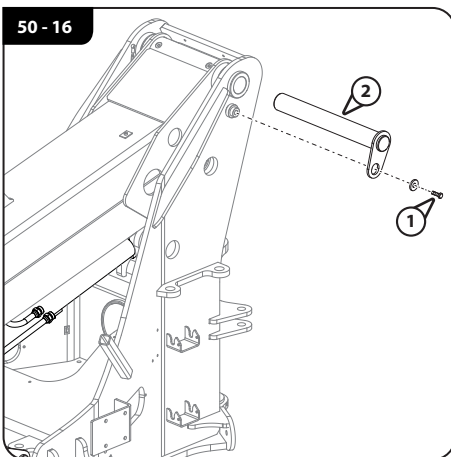

Secure the lift cylinders (1,  50 - 15) to a support.
Slacken the stop screw (2,  50 - 15) and remove the lift cylinders hinge pin (3,  50 - 15) of the rod-boom side.



Slacken the stop screw (1,  50 - 16) and remove the lift cylinders hinge pin (2,  50 - 16) of the rod-boom side.

Ensure that no electric cables or hydraulic pipes remain connected, if they are disconnect them, then remove the boom from the truck, resting it on a horizontal surface or safe supports that can bear the weight.

To reassemble, repeat the operation in reverse order.

70.3 HYDRAULIC CONTROL AND ADJUSTMENT

70.3.1 PRESSURE TEST PORTS

Directional control valve 4 elements

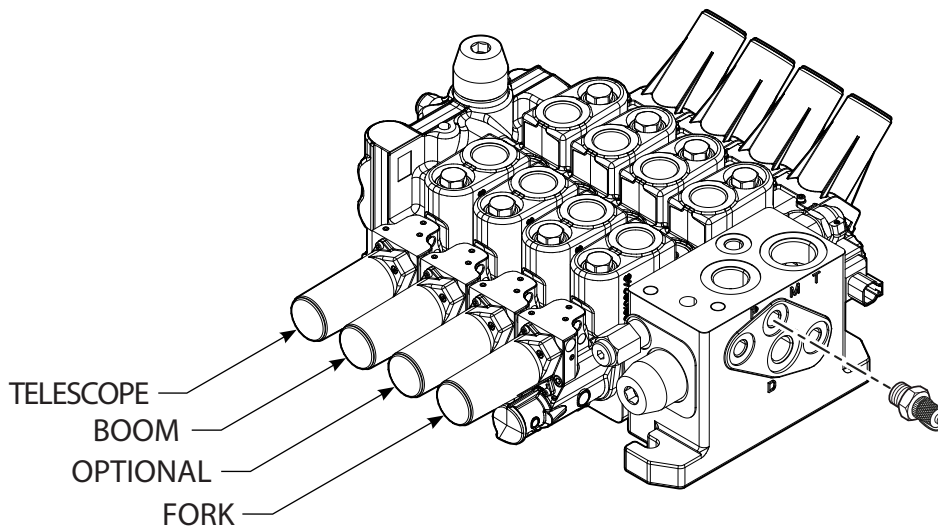
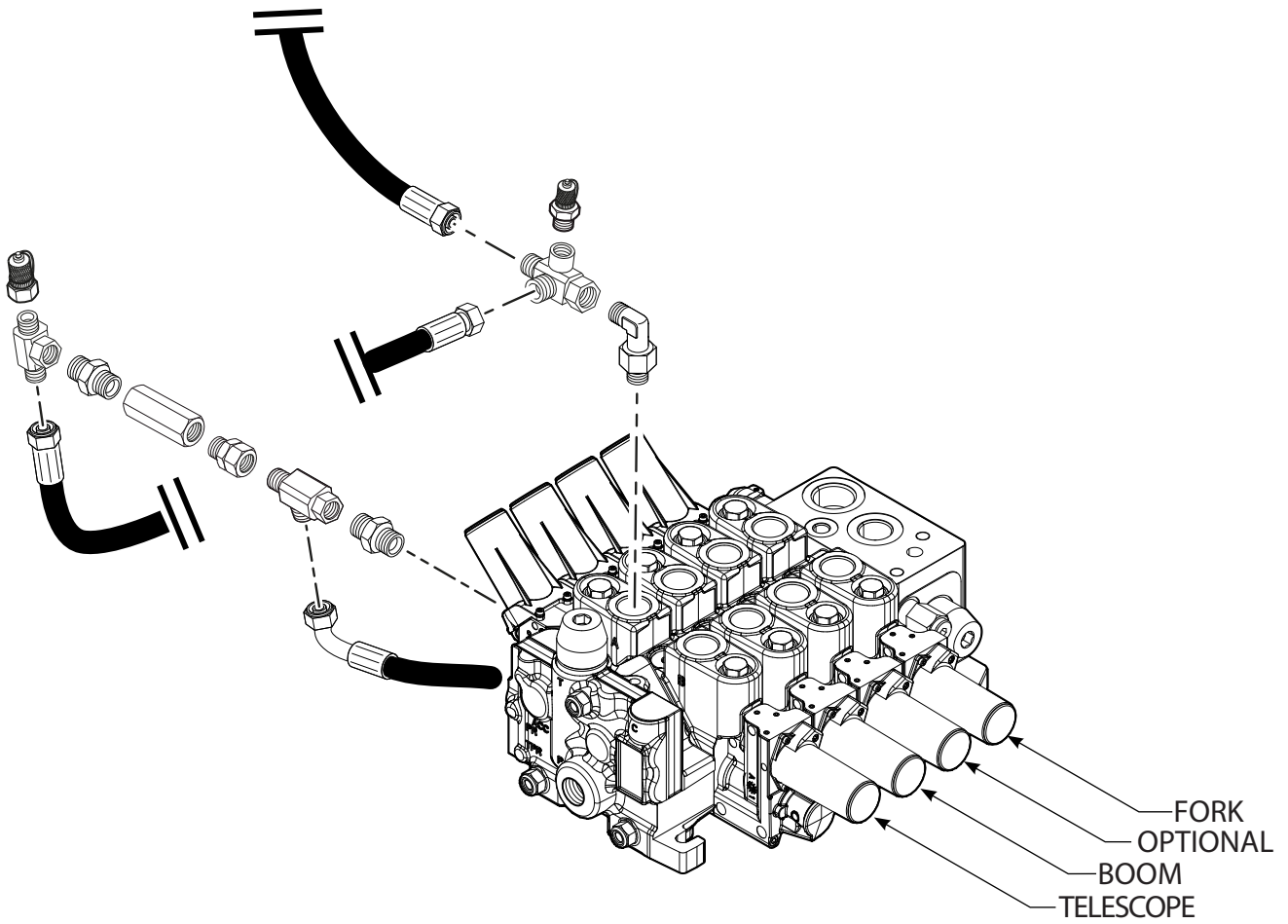



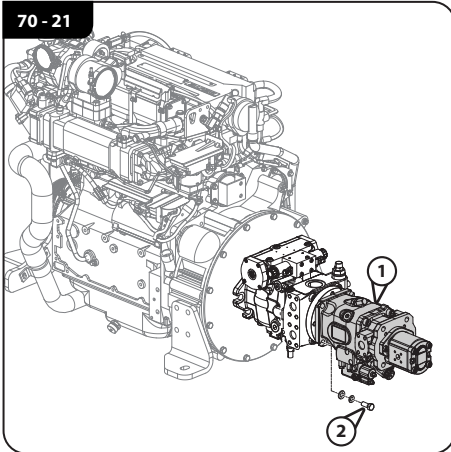

70.4.4 REMOVING THE PUMPS



REMOVING THE SERVICE PUMP



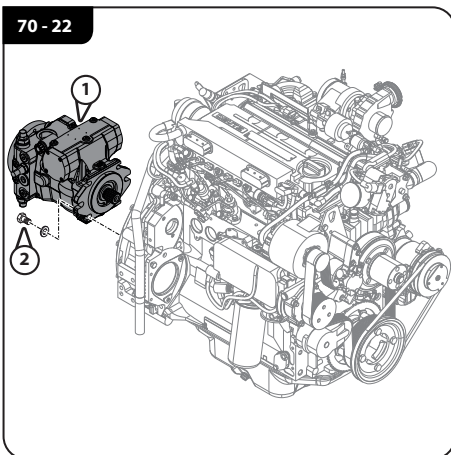

⇒ Carry out the "REMOVING THE ENGINE" operation ◀ 10.5

Secure the service pump (1,  70-21) to appropriate lifting means. Unscrew the screws (2,  70-21) for free service pump (1,  70-21). Remove the service pump (1,  70-21) from the hydraulic pump.







REMOVING THE HYDRAULIC PUMP

First remove the service pump.





Secure the hydraulic pump (1,  70-22) to appropriate lifting means. Unscrew the screws (2,  70-22) for free hydraulic pump (1,  70-22). Remove the hydraulic pump (1,  70-22) from the engine.



CONTROL PANEL





The control panel (1, ) **80 - 2**) with colour screen display shows and informs the operator of all telehandler's working phases.

Four pages are saved in the panel memory and these can be selected by buttons ( , ) **80 - 2**) on the panel.



0. Splash screen (F0, ) **80 - 3**),
1. Driving page (F1, ) **80 - 4**),
2. Working page (F2, ) **80 - 5**),
3. Setting page (subpage) (F3, ) **80 - 6**),
4. Alarms page (F4, ) **80 - 7**).



Push the buttons ( , ) **80 - 2**) to scroll and view the screens.

From "Driving or Working" pages keep pressed the button (, ) **80 - 2**) for 3 seconds to access at the "Setting" subpage. Push button (, ) **80 - 2**) to escape and return in "Driving page" (F1, ) **80 - 2**).

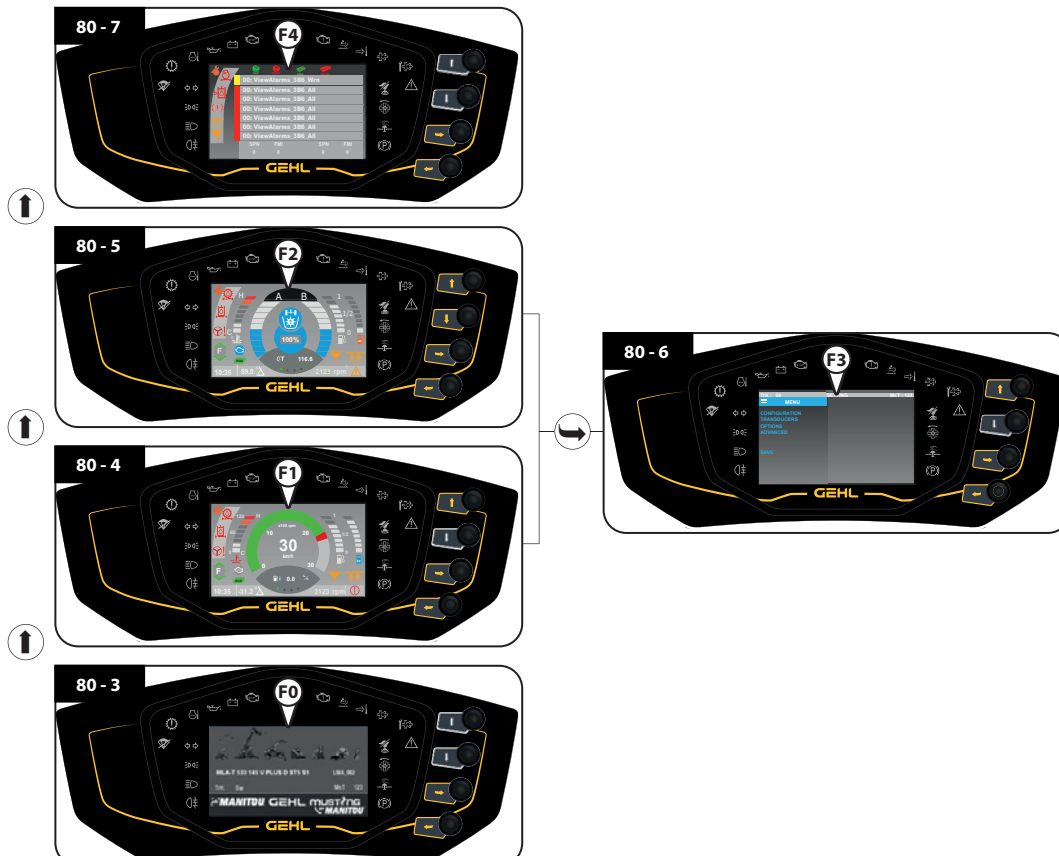
Pages overview:



ALARMS PAGE (F4, 80 - 7)

Once you have entered this page you can only exit with the   arrows on the navigation keypad.

The indicators with the red light on the central unit or the component indicate an error or an anomaly.



1. Warning list (1,  80 - 16)

Example: 123 [code warning] LMI_TXTAL1 [description warning]

2. Alarm list (2,  80 - 16)

Example: 123 [code alarm] LMI_TXTAL1 [description alarm]

3. Messages area (3,  80 - 16)

- Machine alarm code (3a,  80 - 16) is not displayed in normal operating conditions (Show in fault conditionally).
- Machine warning code (3b,  80 - 16) is not displayed in normal operating conditions (Show in fault conditionally).







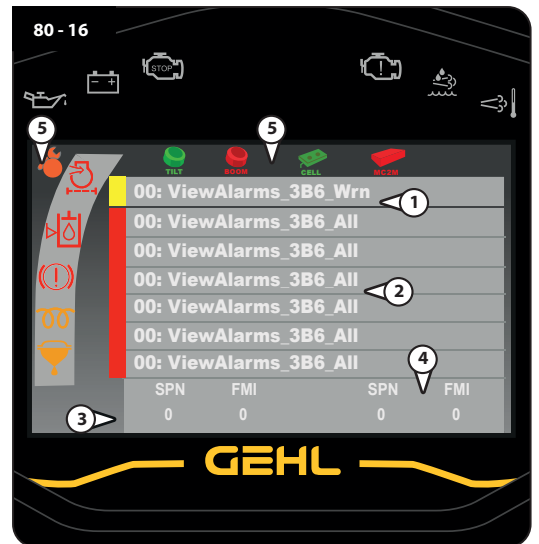

4. Engine unit error codes SPN/FMI (9,  80 - 16)

5. Transmission unit error codes SPN/FMI (9,  80 - 16)



6. Red warning lights (5,  80 - 16)



Symbol

	Display in cab
	MC2M control unit
	Joystick
	Boom angle sensor
	I.C. engine alarm
	LLMI (Safety system)
	Keypad
	Quick coupling potentiometer
	Transmission panel

overview:

Pressing for 10 seconds simultaneously enter and escape (, ) the navigation keypad to enter the page SERVICE.

CLICK HERE TO **DOWNLOAD** THE COMPLETE MANUAL

- Thank you very much for reading the preview of the manual.
- You can download the complete manual from: www.heydownloads.com by clicking the link below



- Please note: If there is no response to CLICKING the link, please download this PDF first and then click on it.

CLICK HERE TO **DOWNLOAD** THE COMPLETE MANUAL

X528 - MC2M (A528)

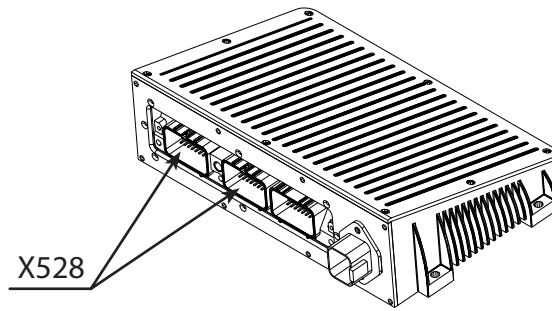

Ref.	Pin	Wire colour	Section	Destination	Function
X528	R3	V	1	X241.p/16	Boom up SV
	R5	V	1	X241.p/15	Boom down SV
	R6	V	1	X241.p/10	SV opt. 1
	R7	V	1	X241.p/13	Boom return SV
	R8	V	1	X241.p/9	SV opt. 2
	R9	V	1	X241.p/14	Boom extension SV
	R15	V	1	X241.p/8	Master SV
	R17	B	1	X519/R3_86	86 reverse light relay
	R23	V	1	SA150	Rear 2nd hydr. opt. SV
	R24	V	1	SA151	Rear opt SV
	R25	B	1	X400.s/12	Hydr. double outlet
	R26	V	1	SA148	Hydr. triple outlet SV
	R27	B	1	SA149	+12 opt. boom from switch
	R28	B	1	X242.p/37	Swivelling angle sig. 1
	R29	B	1	X242.p/38	Swivelling angle sig. 2
	R30	B	1	X242.p/39	ECS sig. from chassis
	R33	B	1	X242.p/24	Boom angle sig. 1
	R35	A	1	X500/4	Park brake micro sig. for detachment
	R38	B	1	X242.p/25	Boom angle sig. 2
	R40	B	5	X454/2	Low press. sig. Brake accumulator
	L1	H	1	X400.s/40	Man. accelerator sig.
	L2	B	1	X500/1	Parking brake indicator light
	L3	B	1	X401/2	Seat micro N.C. sig.
	L4	B	1	X400.s/20	Cont. oil enable sig.
	L5	B	1	X400.s/9	Man present sig.
	L6	B	1	X401/3	Seat micro N.O. sig.
	L7	B	5	X508/1	Eco mode sig.
	L8	V	1	X509/5	Clean Fix SV
	L9	H	1	X510/1	Regeneration inhibited sig.
	L10	B	1	SA54	+50 sig.from em.stop.but.
	L11	A	5	X455/3	Inching pedal sig.
	L12	A	5	X455/6	Inching pedal rid. sig.
	L13	V	1	X241.p/29	Hydr. oil low level sig.
L14	B	1	SA71	Ignition from emergency	
L15	B	1	X400.s/41	Sig.opt. 1 handler	
L16	B	1	X400.s/42	Sig.opt. 2 handler	
L17	B	1	X400.s/6	Handler roller 1 sig.	

Ref.	Pin	Wire colour	Section	Destination	Function
x528	L18	B	1	X400.s/7	Handler roller 2 sig.
	L19	B	1	X400.s/2	Dir.A roller 1 sig.
	L20	B	1	X400.s/3	Dir.B roller 1 sig.
	L21	B	1	X400.s/4	Dir.A roller 2 sig.
	L22	B	1	X400.s/5	Dir.B roller 2 sig.
	L23	B	1	X475/2	Reset manoeuvres sig.
	L24	A	1	SA154	Forward sig.
	L25	A	1	SA155	Reverse sig.
	L26	B	1	X241.p/25	Trailer brake indicator light
	L27	B	1	X464/7	Front wiper 1st speed
	L28	B	1	X464/8	Front wiper 2nd speed
	L29	H	1	SA128	D+ alternator sig.
	L30	B	1	X543/3	N.O. armrest up sig.
	L31	B	1	X242.p/27	Boom susp. press. sig.
	L32	V	1	X242.p/34	Obstructed engine oil filter sig.
	L33	B	1	X101.p/29	Fuel level sig.
	L34	B	1	X464/6	Windscreen washer
	L35	B	1	X242.p/15	N.O. boom withdrawn sig.
	L36	B	1	X242.p/14	N.C. boom withdrawn sig.
	L37				
L38					
L39	B	5	X474/2	Power steering accum. press. sig.	
L40	B	1	X544/5	Heated mirror control sig.	

X245 - SUPERCHARGED AIR COOLER TEMPERATURE SENSOR

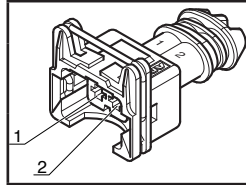
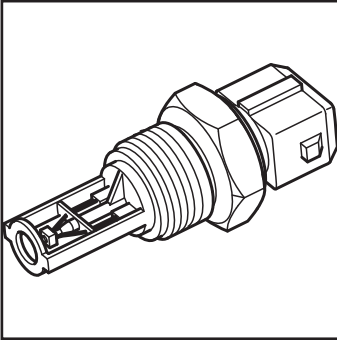

Corresponding connector

PIN	Function
1	Info
2	Ground

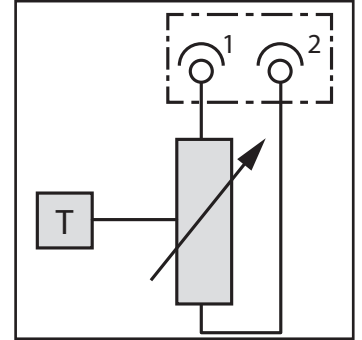

Diagram

Temperature (°C)	Typical (Ω)	Tolerance (Ω)
0	16232	± 894
20	6201	± 282
25	4966	± 221
30	4002	± 169
50	1793	± 57
60	1239	± 42

Comments:

Operating range: -40°C to 150 °C

Type: CTN

Notes: _____

X213 - TRANSMISSION OIL COOLER TEMPERATURE SENSOR

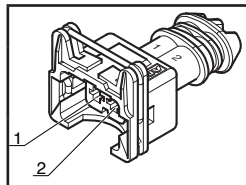
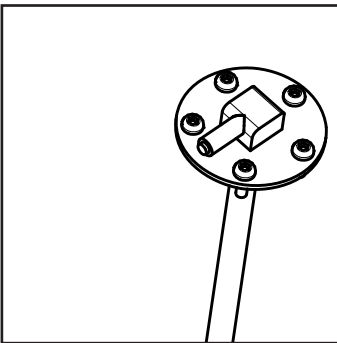

Corresponding connector

PIN	Function
1	info
2	ground

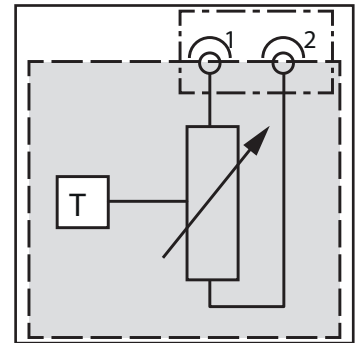

Diagram

	Mini	Maxi
Voltage		25 V
Current		5 mA
Time to reach a constant temperature	4 s (oil)	40 s (air)

Note :

Notes: _____

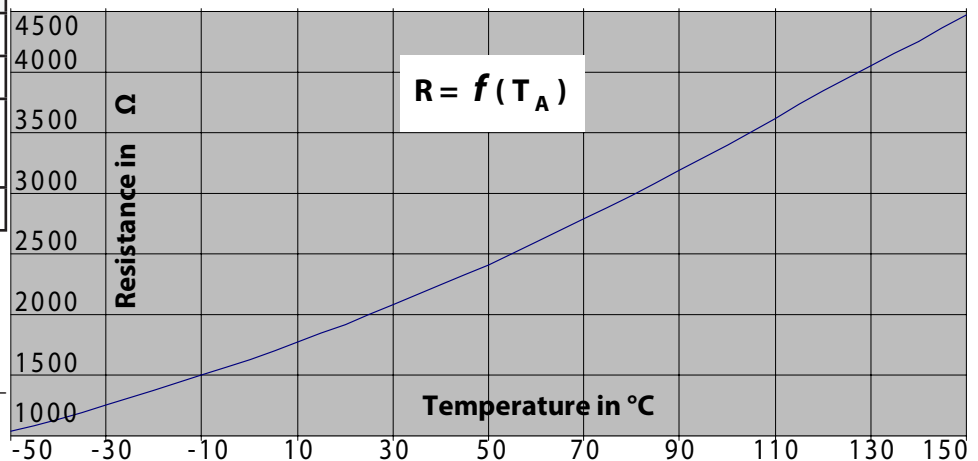

<i>Reference</i>	<i>Pin</i>	<i>Colour</i>	<i>Cross-section</i>	<i>Direction</i>	<i>Wire N°</i>
SA1	-	G	1	X204.p/6	
		G	1	X248.s/2	
		G	1	X208.s/2	
		G	1	X208.s/1	
		G	1	X241.s/23	
SA2	-	G	1	X204.p/2	
		G	1	X208.s/8	
		G	1	X241.s/22	
SA3	-	G	1	X241.s/21	2011
		G	1	X204.p/8	2011
		G	1	X208.s/3	2011
		G	1	X202/2	2011
SA4	-	G	1	X208.s/4	2001
		G	1	X222/3	2001
		G	1	X241.s/20	2001
		G	1	X204.p/5	2001
SA5	-	G	1	X203/1	2000
		G	1	X241.s/18	2000
		G	1	X204.p/7	2000
		G	1	X208.s/5	2000
		G	1	X224/3	2000
SA6	-	G	1	X242.s/32	2002
		G	1	X224/2	2002
		G	1	X208.s/6	2002
		G	1	X204.p/1	2002
SA7	-	G	1	X208.s/7	2003
		G	1	X204.p/4	2003
		G	1	X242.s/31	2003
		G	1	X222/2	2003
SA8	-	C	1	X242.s/30	00F2
		C	1	X221/2	00F2
		C	1	X743/3	00F2
		C	1	X220/1	00F2
SA9	-	Z	1	X218/5	0600
		Z	1	X950/2	0600
		Z	1	X950/5	0600
		Z	1	X242.s/23	0600
		Z	1	X217.p/6	0600
		Z	1	X218/2	0600

Reference	Pin	Colour	Cross-section	Direction	Wire N°
X240	24				
	25				
	26				
	27				
	28	A	0.75	X242.s/35	1339
	29				
	30				
	31	A	0.75	X212/1	1329
	32	Z	0.75	SA26	0609
	33	M	1.5	SA24	0005
	34				
	35				
	36				
	37				
	38				
	39				
	40	C	0.75	X242.s/3	0F80
	41				
	42				
	43				
	44				
	45	R	0.5	SA22	F300
	46	M	1.5	SA24	0005
	47	V	0.75	X234/2	3157
	48				
	49				
	50				
	51				
	52				
	53	G	0.5	SA709	
	54	V	0.5	SA710	
	55	Z	0.75	X212/2	0602
56					
57					
58	R	0.5	SA22	F300	

Reference	Pin	Colour	Cross-section	Direction	Wire N°
X103	85	G	0.5	SA701	
	86	V	0.5	SA702	
	87				
	88				
	89				
	90				
	91	Z	0.75	X101.s/28	0678
X104	1				
	2	B	1.5	X111/19	6781
	3	H	1.5	X140/R1-86	1195
	4	B	0.75	X141/R3-85	7908
	5	V	0.75	X125/11	3258
	6				
	7	H	0.75	X111/52	1063
	8	H	0.75	X111/41	1152
	9	H	0.75	X116/2	1201
	10	H	0.75	B53/1	1004
	11	B	0.75	X112/29	6772
	12				
	13	H	0.75	X112/24	1035
	14	B	0.75	B53/3	6765
	15	H	0.75	X109/2	1201
	16				
	17	Z	0.75	X112/31	0664
	18	B	0.75	X111/24	6783
	19	B	0.75	X125/2	6900
	20	H	0.75	X115/1	1059
	21	B	0.75	X112/22	6771
	22				
	23	H	1.5	X112/32	1110 pin 23
	24	H	1.5	X112/33	1112
	25	H	1.5	X112/20	1160
	26	B	0.75	X108/1	6886
	27	H	0.75	SA531	1188
	28				
	29	H	0.75	X115/3	1218
	30				
	31				
	32	H	0.75	X114/2	1024
	33				
	34				
	35	B	0.75	X112/27	7485

<i>Reference</i>	<i>Pin</i>	<i>Colour</i>	<i>Cross-section</i>	<i>Direction</i>	<i>Wire N°</i>
X880.p	1				
	2				
X880.s	1	H	2.5	X881/87	1030
	2	N	2.5	Gnd5.1	
X881	85	N	1	SA502	
	86	B	1	SA528	6398
	30	R	2.5	X139/18	F507
	87	H	2.5	X880.s/1	1030
	87a				
	1				
	1				
	2				
	3				

Reference	Pin	Colour	Cross-section	Direction	Wire N°
X241.p	1	R	4	X101.p/4	F512
	2				
	3	M	4	SA130	0005
	4	C	2.5	X519/3	0F26
	5	R	0.5	X518/20a	F302
	6	R	1	X518/19	F300
	7	B	1.5	X520/R3_87	6072
	8	V	1	X528/R15	3072
	9	V	1	X528/R8	3117
	10	V	1	X528/R6	3116
	11	V	1	X530/16	3310
	12	V	1	X530/15	3309
	13	V	1	X528/R7	3306
	14	V	1	X528/R9	3305
	15	V	1	X528/R5	3308
	16	V	1	X528/R3	3307
	17	G	1.5	SA811	2047
	18	G	1	X520/1	2000
	19	G	1.5	SA810	2045
	20	G	1	X520/2	2001
	21	G	1	X519/R3_87	2011
	22	G	1.5	X956/R2_87	2015
	23	G	1	X520/R4_87	2012
	24	V	1	SA150	3704
	25	B	1	X528/L26	6846
	26	G	1.5	SA811	2046
	27				
	28	G	1.5	SA810	2044
	29	V	1	X528/L13	3065
X242.p	1	G	2	SA127	2013
	2	B	1	X528/L31	6205
	3	C	1	X518/5	0F80
	4	B	1.5	SA149	6143
	5	G	1	X300.s/15	2081
	6	B	1	X528/R36	6206
	7	V	1	X519/R4_87	3335
	8	B	0.5	SA114	6162
	9	G	0.5	SA102	
	10	V	0.5	SA103	
	11	V	0.5	X501/F	
	12	G	0.5	X501/G	
	13	B	0.5	SA125	6358

Reference	Pin	Colour	Cross-section	Direction	Wire N°
X502	A	C	0.5	X518/3	0F14
	B	N	0.5	Gnd1.1	
	C				
	D				
	E				
	F	V	0.5	SA201	
	G	V	0.5	SA144	
	H	G	0.5	SA143	
	J				
	K				
	L				
	M	G	0.5	SA200	
X506	1	C	1	X518/17	0F69
	2	N	1	Gnd1.3	
	3	L	0.5	SA120	
	4	B	0.5	SA121	
X507	1	C	1.5	X518/8	00F8
	2				
	3				
	4				
	5	B	1.5	X956/R2_30	7417
	6				
	7				
	8				
	9	G	1	X508/9	0F13
		G	1	X400.s/21	0F13
	10	N	1	X508/10	
		N	1	Gnd1.2	
X508	1	B	0.5	X528/L7	7949
	2				
	3				
	4				
	5	C	1	X510/5	00F2
	6				
	7				
	8				
	9	G	1	X507/9	0F13
		G	1	X509/9	0F13
	10	N	1	X507/10	
		N	1	X509/10	

<i>Reference</i>	<i>Pin</i>	<i>Colour</i>	<i>Cross-section</i>	<i>Direction</i>	<i>Wire N°</i>	
X528	L20	B	1	X400.s/3	6881	
	L21	B	1	X400.s/4	6882	
	L22	B	1	X400.s/5	6883	
	L23	B	1	X475/2	6038	
	L24	A	1	SA154	1326	
	L25	A	1	SA155	1327	
	L26	B	1	X241.p/25	6846	
	L27	B	1	X464/7	7264	
	L28	B	1	X464/8	7265	
	L29	H	1	X101.p/24	1007	
	L30	B	1	X543/3	7472	
	L31	B	1	X242.p/2	6205	
	L32	V	1	X242.p/34	3021	
	L33	B	1	X101.p/29	6021	
	L34	B	1	X464/6	6122	
	L35	B	1	X242.p/14	6844	
	L36	B	1	X242.p/15	6845	
	L37					
	L38					
	L39	B	1	X400.s/48	8458	
L40	B	1	X544/5	6743		
X529	1	C	2.5	SA64	0407	
	2	C	2.5	SA64	0407	
	3	C	2.5	SA64	0407	
	4	N	2.5	Gnd1.2		

Reference	Pin	Colour	Cross-section	Direction	Wire N°
X318	1	G	1.5	SA812	2004
	2				
	3				
	4				
	5	C	1.5	X300.p/5	00F6
		C	1	X318/9	00F6
	6				
	7				
	8				
	9	C	1	X318/5	00F6
	10	N	1	X325/10	
		N	1	X316/10	
X319	1				
	2	C	1.5	X300.p/12	00F9
		C	1	X319/9	00F9
	3				
	4	B	1	X300.p/10	6862
	5	B	1	X309/3	6551
	6				
	7	B	1	X309/4	6562
	8				
	9	C	1	X319/2	00F9
	10	N	1	X325/10	
X320.1	-	B	1	X301.p/12	7106
X320.2	-	B	1	X301.p/7	7101
X320.3	-	B	1	X301.p/11	7105
X320.4	-	B	1	X301.p/13	7461
X320.5	-	N	1	Gnd14.2	
X321.1	-	B	1	X301.p/9	7102
X321.2	-	B	1	X301.p/7	7101
X321.3	-	B	1	X301.p/8	7103
X321.4	-	B	1	X301.p/10	7460
X321.5	-	N	1	Gnd14.1	
X323.1	-	G	1	SA800	2081
X323.2	-	N	1	Gnd14.1	
X324.1	-	G	1	SA800	2081
X324.2	-	N	1	Gnd14.2	

Reference	Pin	Colour	Cross-section	Direction	Wire N°
X485	1	B	1	X450,p/13	6584
	2	B	1	X450,p/16	7500
	3	B	1	X476,p/8	6941
	4	B	1	X476,p/7	7497
	5	B	1	X450,p/5	7499
	6	B	1	X476,p/5	7018
	7	B	1	X450,p/12	6585
	8	B	1	X450,p/21	7501
	9	B	1	X476,p/9	7494
	10	B	1	X450,p/10	7496
	11	B	1	X450,p/7	7498
	12	B	1	SA180	7002
X486	1	B	1	X450,p/14	6911
	2	B	1	X450,p/11	6912
	3	B	1	X450,p/9	6914
	4	B	1	X450,p/4	7503
	5	Z	1	X450,p/3	0635
	6				
	7	N	1	SA181	
	8	B	1	SA180	7002
	9	B	1	X450,p/2	7502
	10	B	1	X450,p/15	6914
X487	1				
	2	B	1	X450,p/17	7332
	3				
	4	B	1	X450,p/19	7333
	5				
	6	B	1	X450,p/18	7334
	7				
	8	B	1	X450,p/20	7335

80.2.3 WIRING DIAGRAMS

POSITION OF CONNECTORS BY DIAGRAM

Connector	Diag. 1	Diag. 2	Diag. 3	Diag. 4	Diag. 5	Diag. 6	Diag. 7	Diag. 8	Diag. 9	Diag. 10	Diag. 11.1	Diag. 11.2
A4			√									
A6		√										
A7			√									
A103	√	√		√		√						
A111	√	√		√		√						
A218						√						
A239	√	√	√	√	√							
A471							√					
A528	√	√	√	√	√	√			√	√	√	
A873				√								
A952											√	
A		√										
B1					√							
B3		√										
B4		√										
B5		√										
B6		√										
B53						√						
B100								√				
B101								√				
B109						√						
B110						√						
B113						√						
B114						√						
B115						√						
B116						√						
B121						√						
B122						√						
B123		√										
B124		√										
B125						√						
B126	√											
B127						√						
B131						√						
B132		√										
B201						√						
B205						√						
B212						√						
B213						√						
B214						√						
B215						√						
B220				√								
B221				√								
B234						√						
B401				√								
B454						√						
B456								√				
B474						√						

Connector	Diag. 1	Diag. 2	Diag. 3	Diag. 4	Diag. 5	Diag. 6	Diag. 7	Diag. 8	Diag. 9	Diag. 10	Diag. 11.1	Diag. 11.2
B475						√						
B489							√					
B490							√					
B500				√								
B511										√		
B543						√						
B592								√				
B743						√						
B950						√						
B		√										
C3			√									
C5		√										
C			√									
D3			√									
D5		√										
D6			√									
D			√									
E5		√										
E203									√			
E219									√			
E222									√			
E224									√			
E280A									√			
E280B									√			
E280C									√			
E281A									√			
E281B									√			
E281C									√			
E281D									√			
E303										√		
E304										√		
E305										√		
E306										√		
E307										√		√
E312										√		
E323										√		
E324										√		
E327									√			
E777												√
E778												√
E		√										
EP172												√
EP173												√
EV1						√						
EV1.												√
EV2						√						
EV3						√						
F100												√

DIAGRAM 6 (SENSORS)

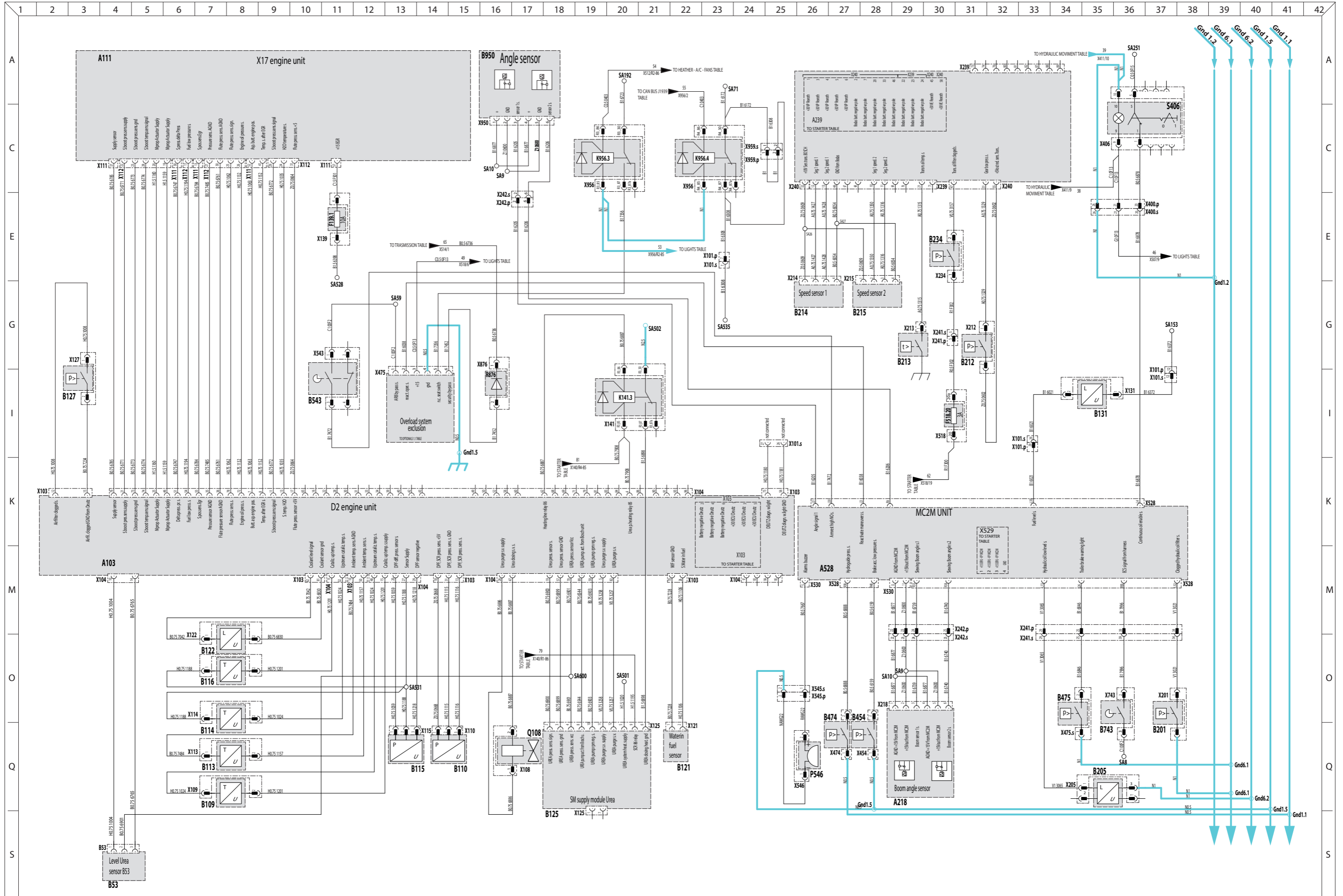

Ref.	Description	3d WIRNING								2d WIRNING						
		Chassis / Rear lamp	Engine	Cabin 1.1	Cabin 1.2	Cabin heating / Armrest	Cabin roof	Opt 1.1	Opt1.2	Cabin	Chassis	Engine	Roof / Bacon lamp / Cabin heating	Cabin armrest / Boom / Arb	Opt 1.1	Opt1.2
X850.1	Contact nc (Ignition)													K3 / K4		
X850.2	Contact nc (Ignition)													K4 / K5		
X851	Start +50 emergency push button					C35										
X851.1	Contact nc (+ 50 start)													K6 / K7		
X851.2	Contact nc (+ 50 start)													K7 / K8		
X870	Rexroth positive push button															
X870.1	Contact nc (+ rexroth)													K9		
X870.2	Contact nc (+ rexroth)													K10 / K11		
X871	Contact nc (- rexroth)					C35										
X871.1	Contact nc (- rexroth)													K11 / K12		
X871.2	Contact nc (- rexroth)													K13 / K14		
X872	Rear view camera			I19 / I20					O13 / O14						I11 / I12	
X872.p	Rear view camera									S20 / S21						
X872.s	Rear view camera									Q20 / Q21						
X873	Tp22 unit			K19 / K20						Q22						
X874	Buzzer			K19 / K20												
X874.p	Buzzer									S24 / S25						
X874.s	Buzzer									Q23 / Q24						
X875	Pulsante test freno rimorchio			I18				C23 / C24		E27 / E28						
X876	diode			C30 / C31 / E30 / E31						C21 / C22						
X877	Diode									C22 / C23						
X880.s	Alternator resistance		M25 / M26									G15 / G16				
X881	Preheating fuel relay		A39 / A40									O4 / O5				
X888A	2ND Boom head exit harness															K24 / K25
X889	2ND Boom head exit inteface															K19
X892	Buzzer									S24 / S25						
X911.s	Boom lights interface								A3							E24 / E25
X950	Angle sensor xsa	S8									C10					
X951	Automatic gras optional	S7 / S8									C11 / C12					
X952	Xes - eco stop										C18					
X955	Auto greaser w.light			O15							M20 / M21					
X956	Relay / fuse module			E18 / E19	M4 / M5						Q41					
X957.s	High beams diode			C30 / C31 / E30 / E31							C24					
X958	Diode			C30 / C31 / E30 / E31							C25					
X959	Bridge connection ECO-STOP			E18 / E19												
X959.p	Bridge connection ECO-STOP										K40 / K41					
X959.s	Bridge connection ECO-STOP										M40 / M41					
X960	Switch eco stop								C20					K19 / K20		
X961	Dead man switch													G6		
X962.s	Ready connector			A26 / A27							M39 / M40					
X1002	Grounding		M2 / M3													
X1003	Starter		C5 / C6 / K6 / K7													
X1004	Alternator		G22 / G23 / O16 / O17													
X1005	Engine		K8 / M8 / Q5 / Q6 / S5 / S6													
X1006	Grounding		M7													

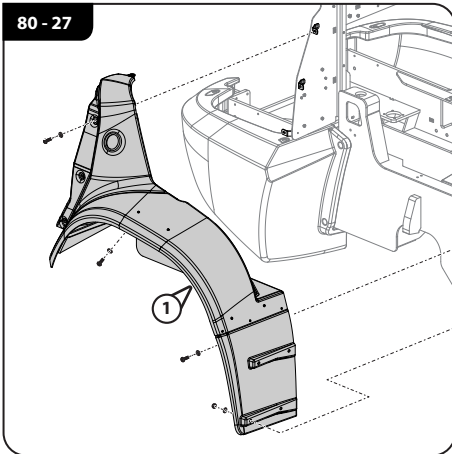

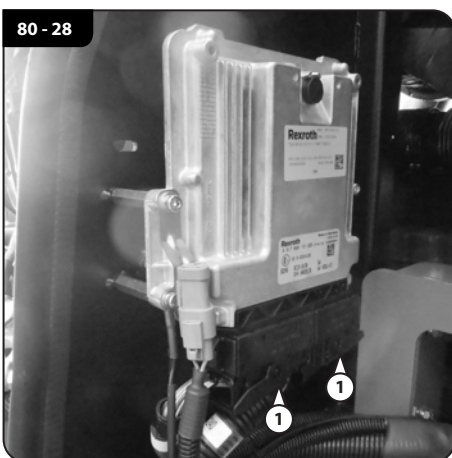

Removing the right mudguard (1,  80 - 27).

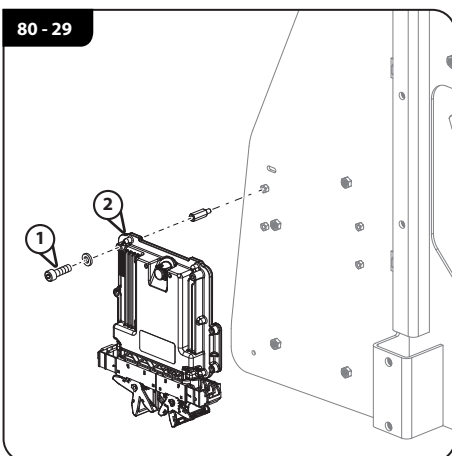

Disconnect the 2 connectors (1,  80 - 28).



Unscrew the screws (1,  80 - 29) and remove the Rexroth ECU (2,  80 - 29).

To reassemble, repeat the operation in reverse order.

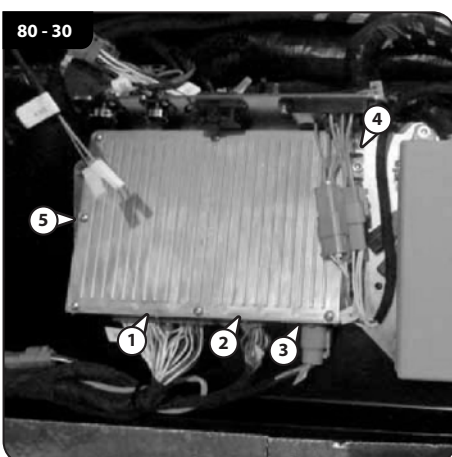

80.4.4 ECU MC2M



Located behind the driver's seat, under the cover.

Disconnect the 3 connectors

X528 (1,  80 - 30)

X530 (2,  80 - 30)

X529 (3,  80 - 30)





Remove the screw (4,  80 - 30) to free the MC2M (5,  80 - 30)

To reassemble, repeat the operation in reverse order.

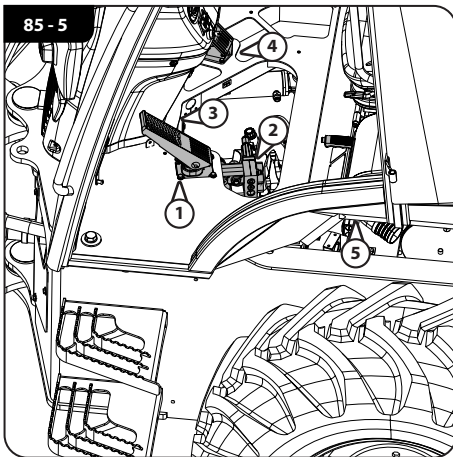
Code	SPN	FMI	Blink code	Error Identification
570	653	5	156	Injector 3 (in firing order): Interruption of electric connection.
571	654	5	161	Injector 4 (in firing order): Interruption of electric connection.
572	655	5	162	Injector 5 (in firing order): Interruption of electric connection.
573	656	5	163	Injector 6 (in firing order): Interruption of electric connection.
575	523756	14	1-5-5	special pattern for special cases No detail informationen!
576	523757	14	1-5-6	special pattern for special cases No detail informationen!
577	523758	14	1-6-1	special pattern for special cases No detail informationen!
578	523759	14	1-6-2	special pattern for special cases No detail informationen!
579	523760	14	1-6-3	special pattern for special cases No detail informationen!
580	651	3	154	Injector 1 (in firing order): Short circuit.
581	652	3	155	Injector 2 (in firing order): Short circuit.
582	653	3	156	Injector 3 (in firing order): Short circuit.
583	654	3	161	Injector 4 (in firing order): Short circuit.
584	655	3	162	Injector 5 (in firing order): Short circuit.
585	656	3	163	Injector 6 (in firing order): Short circuit.
590	655	4	1-6-2	High side to low side short circuit in the injector 5 (in firing order)
591	656	4	1-6-3	High side to low side short circuit in the injector 6 (in firing order)
592	523615	5	135	Metering unit (Fuel-System): Open load.
593	523615	12	135	Metering unit (Fuel-System): Powerstage over temperature.
594	523615	3	135	Metering unit (Fuel-System): Short circuit to battery, highside.
595	523615	4	135	Metering unit (Fuel-System): Short circuit to ground, high side.
596	523615	3	135	Metering unit (Fuel-System): Short circuit to battery, low side.
597	523615	4	135	Metering Unit (Fuel-System): Short circuit to ground, low side.
598	523615	3	1-3-5	Metering unit, short circuit to battery
599	523615	4	1-3-5	Metering unit, short circuit to ground
604	1323	12	2-4-1	Too many recognized misfires in cylinder 1 (in firing order)
605	1323	12	2-4-1	Too many recognized misfires in cylinder 2 (in firing order)
606	1323	12	2-4-1	Too many recognized misfires in cylinder 3 (in firing order)
607	1323	12	2-4-1	Too many recognized misfires in cylinder 4 (in firing order)
608	1323	12	2-4-1	Too many recognized misfires in cylinder 5 (in firing order)
609	1323	12	2-4-1	Too many recognized misfires in cylinder 6 (in firing order)
610	1322	12	2-4-1	-
611	1346	0	2-4-1	Misfire detection monitoring No detail informationen!
612	523612	12	555	Internal ECU monitoring detection reported error
613	523612	12	555	ECU reported internal software error Internal ECU monitoring detection reported error
614	523612	12	555	ECU reported internal software error
615	523612	12	555	ECU reported internal software error.
616	523612	12	555	ECU reported internal software error
617	523612	12	555	ECU reported internal software error
618	523612	12	555	ECU reported internal software error
619	523612	12	555	Injection system,electrical error injectors
620	523612	12	555	ECU reported internal software error
621	523612	12	555	ECU reported internal software error
623	523612	12	555	ECU reported internal software error
624	523612	12	555	ECU reported internal software error
625	523612	12	555	ECU reported internal software error
627	523612	12	555	ECU reported internal software error
628	523612	12	555	ECU reported internal software error
629	523612	12	555	Diagnostic fault check to report the accelerator pedal position error
630	523612	12	555	Diagnostic fault check to report the engine speed error
631	523612	12	555	Error in the plausibility of the injection energizing time

Code	SPN	FMI	Blink code	Error Identification
1659	524114	9	9-3-8	Timeout error of CAN-Transmit-Frame A1DOC
1660	524115	9	9-3-9	Timeout error of CAN-Transmit-Frame AT15
1661	524116	9	1-9-4	Timeout error of CAN-Transmit-Frame SCR2
1662	524117	9	9-4-1	Timeout error of CAN-Transmit-Frame SCR3
1663	524097	9	9-2-1	Timeout error of CAN-Transmit-Frame DPFBrnAirPmpCtl
1664	524098	9	9-2-2	Timeout error of CAN-Transmit-Frame ComDPFBrnPT
1665	524099	9	9-2-3	Timeout error of CAN-Transmit-Frame ComDPFC1
1666	524100	9	9-2-4	Timeout error of CAN-Transmit-Frame ComDPFHisDat.
1667	524101	9	9-2-5	Timeout error of CAN-Transmit-Frame ComDPFstMon
1668	524105	9	9-2-9	Timeout error of CAN-Transmit-Frame ComEGRMsFlw (EGR Steller)
1669	524108	9	9-3-2	Timeout error of CAN-Transmit-Frame ComEGRTVActr (EGR actuator)
1670	524110	9	9-3-4	Timeout error of CAN-Transmit-Frame ComETVActrTO.
1671	524112	9	9-3-6	Timeout ComIntake Throttle Valve Actr.
1672	524118	9	9-4-2	Timeout error of CAN-Receive-Frame ComRxCM1
1675	524103	9	9-2-7	Timeout error of CAN-Receive-Frame ComRxDPFBrnAirPmp
1676	524104	9	9-2-8	Timeout error of CAN-Receive-Frame ComRxDPFCtl.
1677	524106	9	1-9-5	Timeout error of CAN-Receive-Frame ComRxEGRMsFlw1 (EGR actuator)
1678	524107	9	9-3-1	Timeout error of CAN-Receive-Frame ComRxEGRMsFlw2 (EGR actuator)
1679	524109	9	9-3-3	Timeout error of CAN-Receive-Frame ComRxEGRTVActr (EGR actuator)
1680	524111	9	9-3-5	Timeout error of CAN-Receive-Frame ComRxETVActr
1681	524113	9	9-3-7	Timeout error of CAN-Receive-Frame ComRxITVActr
1682	524120	9	9-4-4	Timeout error of CAN-Receive-Frame ComRxSCRHtDiag
1683	524121	9	9-4-5	Timeout error of CAN-Receive-Frame ComRxTrbChActr (wastegate actuator)
1684	524122	9	9-4-6	Timeout error of CAN-Receive-Frame ComRxUQSens (Urea quality)
1685	524123	9	9-4-7	Timeout error of CAN-Receive-Frame ComSCRHtCtl
1686	524124	9	9-4-8	Timeout error of CAN-Receive-Frame ComTxAT1IMG
1687	524125	9	9-4-9	Timeout error of CAN-Receive-Frame ComTxTrbChActr (Wastegate actuator)
1698	524133	2	9-5-6	Override Switch is pressed all the time
1699	524134	0	9-5-7	DPF, ash load exceeds the shutoff threshold
1700	524134	0	9-5-7	DPF, ash load exceeds the warning threshold
1701	524135	0	9-5-8	DPF, soot load exceeds the shutoff threshold
1702	524135	14	9-5-8	DPF, soot load exceeds the service request threshold
1703	524135	0	9-5-8	DPF, soot load exceeds the warning threshold
1705	524156	9	9-7-2	Timeout error of CAN-Receive-Frame ComRxEBC2.
1706	524157	9	9-7-3	Fancontrol; time out for fan governing
1708	524159	0	9-7-5	Fan; short circuit battery or open load
1709	524159	1	9-7-5	Fan; short circuit ground
1710	524160	5	9-7-6	Fan; in/outlet valve 1; open load
1712	524160	3	9-7-6	Fan; in/outlet valve 1; short circuit battery
1713	524160	4	9-7-6	Fan; in/outlet valve 1; open load ground
1714	524161	5	9-7-7	Fan; in/outlet valve 2; open load
1716	524161	3	9-7-7	Fan; in/outlet valve 2; short circuit battery
1717	524161	4	9-7-7	Fan; in/outlet valve 2; open load ground
1718	524162	12	9-7-8	Fan; fancontrol; angle sensor defect
1719	524163	12	9-7-9	Fan; fancontrol; fan or valve defect
1752	2791	7	4-1-5	EGR actuator, actuator blocked
1753	2791	2	4-1-5	EGR actuator, CAN error
1754	2791	13	4-1-5	EGR actuator, EOL calibration error
1755	2791	12	4-1-5	EGR Actuator, internal electrical fault.
1756	2791	13	4-1-5	EGR actuator, learning process aborted.
1757	2791	6	4-1-5	EGR actuator current is above maximum threshold.



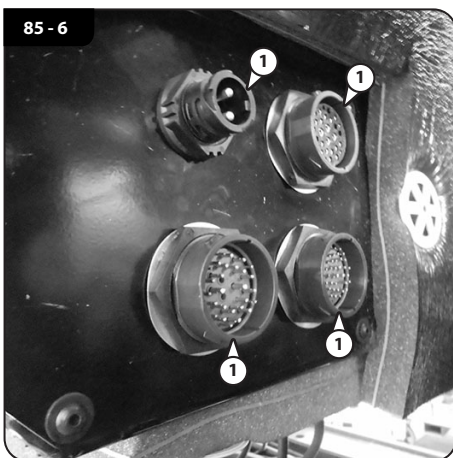

Unscrew the screws (1, ) 85 - 5) and remove the brake pump (2, ) 85 - 5) from the cabin.
Remove the tubes (3, ) 85 - 5) for hydraulic steering under the cab.
Disconnect the pedal accelerator connector (4, ) 85 - 5).
Disconnect the brake stop cable and connector under the cabin (5, ) 85 - 5).



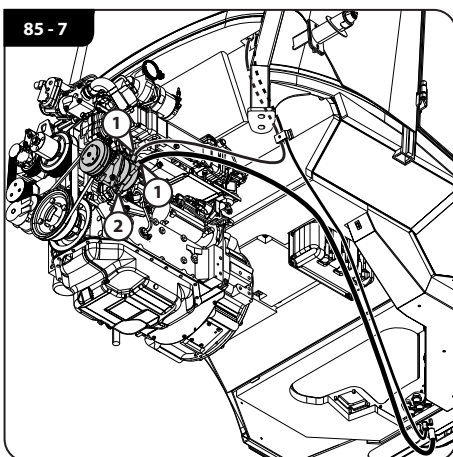

Disconnect the electrical connectors (3, ) 85 - 6) on cabin in the external lower left part.

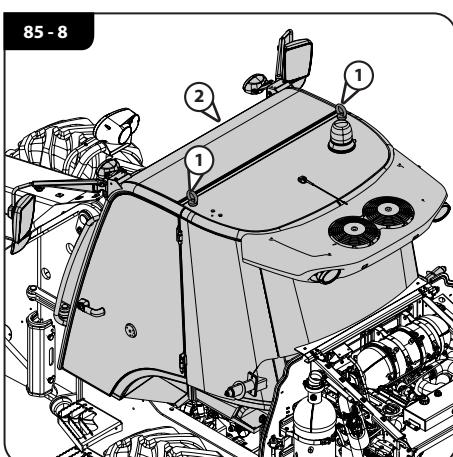

OPTIONAL A/C

If equipped with kit air conditioning remove the tube (1, ) 85 - 7) from compressor (2, ) 85 - 7).



Fit the eyebolts (2, ) 85 - 8) on the cabin (2, ) 85 - 8) and secure it to an overhead crane by means of chains.

CLICK HERE TO **DOWNLOAD** THE COMPLETE MANUAL

- Thank you very much for reading the preview of the manual.
- You can download the complete manual from: www.heydownloads.com by clicking the link below



- Please note: If there is no response to CLICKING the link, please download this PDF first and then click on it.

CLICK HERE TO **DOWNLOAD** THE COMPLETE MANUAL