



BP 249 Z. I.
44 158 ANCENIS CEDEX FRANCE
TEL : +33 (0)2 40 09 10 11

YOUR CONCESSIONARY

REF : 547 343 EN (01 / 02)

**ACCESS
PLATFORM
165 ATJ
REPAIRS MANUAL**

CLICK HERE TO **DOWNLOAD** THE COMPLETE MANUAL

- Thank you very much for reading the preview of the manual.
- You can download the complete manual from: www.heydownloads.com by clicking the link below



- Please note: If there is no response to CLICKING the link, please download this PDF first and then click on it.

CLICK HERE TO **DOWNLOAD** THE COMPLETE MANUAL

TECHNICAL CHARACTERISTICS

165 ATJ

0-1-M.53 EN

GROUPS 10

I.C. ENGINE

Contents

General information	10
Specifications	11
SERVICE OPERATIONS	
Cylinder head assembly	12
Piston and connecting rod assemblies	13
Crankshaft assembly	14
Timing case and drive assembly	15
Cylinder block assembly	16
Engine timing	17
Aspiration system	18
Lubrication system	19
Fuel system	20
Cooling system	21
Flywheel and housing	22
Electrical equipment	23
Auxiliary equipment	24
List of special tools	25

Specifications

11

Basic engine data	11A
Recommended torque tensions	11B

Rocker cover

To remove and to fit

12A-01

Early engines are supplied with an aluminium rocker cover. The latest engines have a plastic rocker cover. Both of these covers have a seal (B1) fitted in the flange.

To remove

- 1 Disconnect the breather pipe.
- 2 Remove the two cap nuts (A1). Each cap nut has a steel washer (A2), a shim washer (A3) and a rubber seal (A4).

Note: The shim washers are not used with the plastic rocker covers.

- 3 Lift off the rocker cover.

To fit

- 1 Check the condition of the rubber seals (A4), the steel washers (A2) and the shim washers (A3) for the cap nuts (A1). If necessary, the seals for the cap nuts can be renewed.

Note: The shim washers are not used with the plastic rocker covers.

- 2 Check the condition of the rocker cover seal (B1). If necessary, the seal can be renewed.
- 3 Clean the seal face of the cylinder head and fit the rocker cover.
- 4 Fit the steel washer, the shim and the seal to each cap nut and fit the cap nuts.

Caution: Damage to the seals can occur if the cap nuts are not tightened centrally through the sealing washer and the rocker cover. If the seals are damaged they must be renewed.

- 5 Tighten the cap nuts to 30 Nm (22 lbf ft) 3,1 kgf m for the aluminium rocker cover, or 20 Nm (15 lbf ft) 2,0 kgf m for the plastic rocker cover.

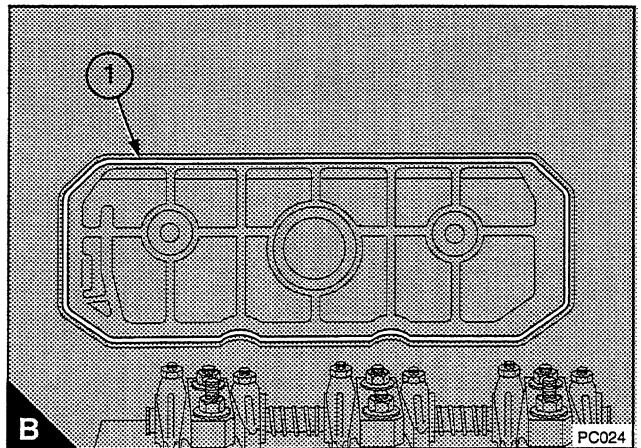
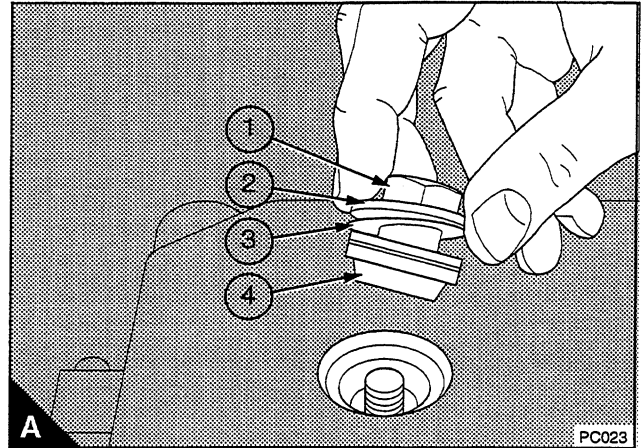

5 Clean and dry the tappets and their parent bores in the cylinder head. Fit the tappets (A1) into their parent bores. As the tappets are in the cylinder head, they can fall when the cylinder head is fitted. To prevent this, use six pieces of rubber hose (B2) to retain each tappet (B4). Cut a piece out of one end of each hose (B3); push this end onto the end of the tappet (B1). The gap in the hose is necessary because there is very little clearance between the cylinder head and the tappet.

6 Carefully fit the cylinder head. Ensure that the cylinder head is fully onto the two location pins, but do not damage the gasket.

7 Remove the pieces of hose which retained the tappets. Lubricate thoroughly the tappets with clean engine lubricating oil. Check that the tappets are free to move in their parent bores.

8 Lightly lubricate the threads of the eight cylinder head setscrews and the thrust faces of the setscrew heads. Lightly lubricate the threads of the studs and the thrust faces of the four nuts. Fit the setscrews and the nuts and tighten them finger tight.

To tighten the setscrews:

Caution:

- Do not tighten the cylinder head fasteners again with the engine hot or after a limited period in service.
- The cylinder head setscrews are tightened in **four increments**, see paragraphs 9 to 12. Cylinder head fasteners which are tightened in one operation can loosen in service.

9 Tighten setscrews 1 - 8 in the correct sequence (C) to 90 Nm (66 lbf ft) 7,2 kgf m.

10 Repeat paragraph 9 to ensure that all the setscrews are tightened to the correct torque.

Continued

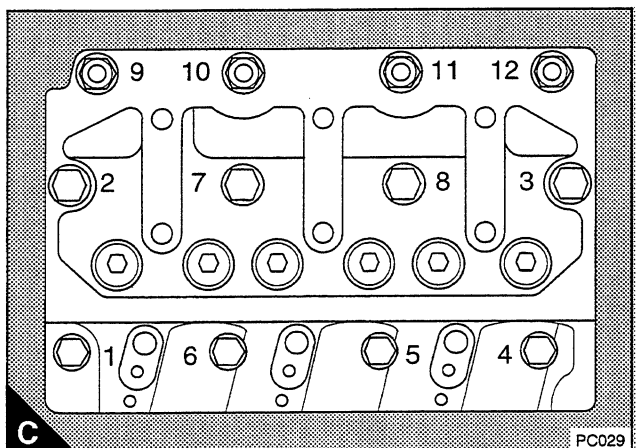
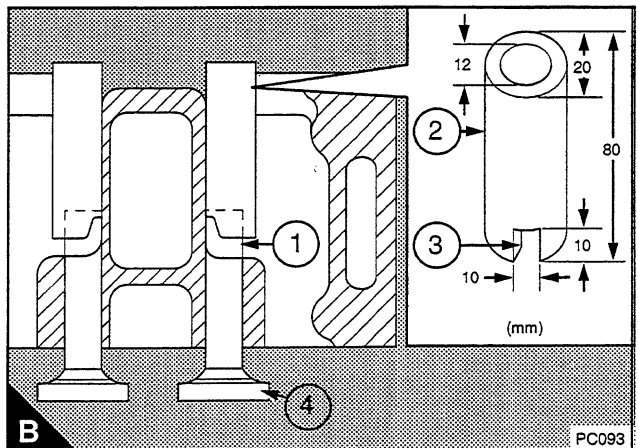
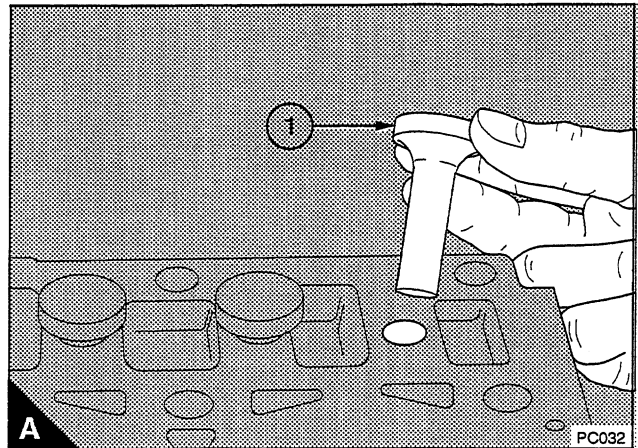

Valve guides

To inspect

12A-10

To check the valve guides for wear: The maximum clearance (A5), between the valve stem and the bore of the guide is 0,15 mm (0.006 in) for inlet valves and 0,14 mm (0.005 in) for exhaust valves. If the clearance, with a new valve fitted, is more than the limit, then a new valve guide (A4) must be fitted.

It is recommended that the procedure given below is used to check the valve guide clearance:

- 1 Put a new valve in the valve guide.
- 2 Put a dial test indicator with a magnetic base (A1) onto the face of the cylinder head
- 3 With the valve lifted 15,0 mm (0.6 in) and the gauge (A2) in contact with the edge of the valve head (A3), move the valve radially away from the gauge. With the valve held in this position, set the gauge zero.
- 4 Move the valve radially across the axis of the cylinder head towards the gauge. Make a note of the reading on the gauge. If the reading is equal to or greater than the data given below, a new valve guide (A4) must be fitted.

Maximum permissible clearance with a valve lift of 15,0 mm (0.6 in) :

- Inlet guide 0,24 mm (0.009 in)
- Exhaust guide 0,28 mm (0.011)

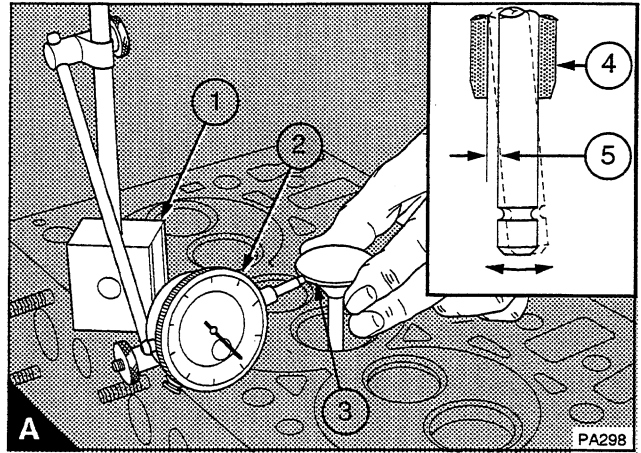

Piston and connecting rod assembly **13**

General description	13A.02
Big end bearing	
13A-01 To remove and to fit	13A.03
13A-02 To inspect	13A.04
Piston and connecting rod assembly	
13A-03 To remove and to fit	13A.05
13A-03A To check the piston height above the cylinder block	13A.08
13A-03B To check the height grade of a piston	13A.09
13A-04 To dismantle and to assemble	13A.10
Piston rings	
13A-05 To remove and to fit	13A.11
13A-06 To inspect	13A.12
Connecting rod	
13A-07 To inspect	13A.13
Small end bush	
13A-08 To remove and to fit	13A.13
Data and dimensions	13A.14

Piston rings

To remove and to fit

13A-05

The piston used in the 900 Series engines have two compression rings and an oil control ring. All the piston rings are above the gudgeon pin. To ensure that the correct piston rings is obtained, always use the full engine number to order new parts.

Caution: Only expand the ring gaps enough to ensure that the ends of the rings do not damage the piston when the ring is removed or put into position.

To remove

Remove the piston rings with a suitable ring expander. Keep the rings with their relevant piston.

To fit

Use a suitable piston ring expander to fit the piston rings.

1 Fit the spring (A3) of the oil control ring in the bottom groove of the piston, with the latch pin (B1) inside both ends of the spring. Fit the oil control ring over the spring. Ensure that the ring gap is at 180° to the latch pin. The manufacturers symbol or the word 'TOP', must be towards the top of the piston.

A new oil control ring has a blue identification mark which must be on the left of the ring gap when the ring is fitted and the piston is upright.

2 Fit the cast iron ring with the taper face (A2) into the second groove of the piston. The manufacturers symbol or the word 'TOP', must be towards the top of the piston.

New second rings have a green identification mark which must be on the left of the ring gap when the ring is fitted and the piston is upright.

The second ring has a chamfer (A4) on the inner, bottom face.

3 Fit the top ring, the manufacturers symbol or the word 'TOP', must be towards the top of the piston. A new top ring has a red identification mark which must be on the left of the ring gap when the ring is fitted and the piston is upright. The top ring has a small curve on the outer face (A1).

4 Ensure that the ring gaps are 120° apart.

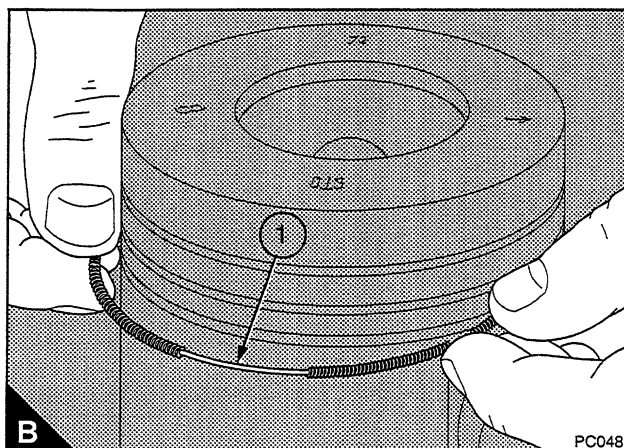
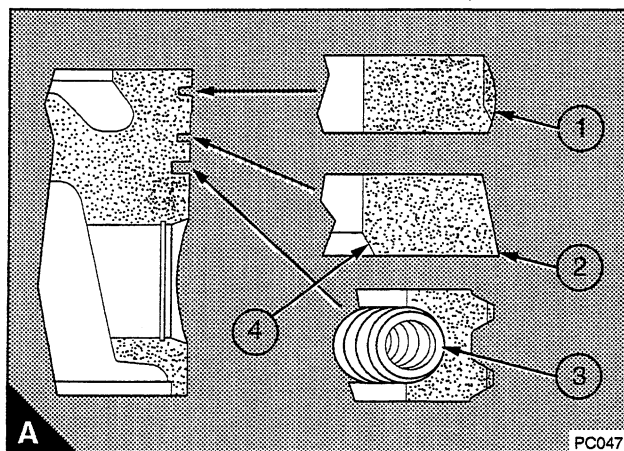

To renew the rear oil seal

14A-03

Special tools:

Replacer tool for rear oil seal, part number 21825540

There are three positions in which the seal can be fitted in the housing (A).

Position "1" (A1) is used when a new seal is first fitted in service.

Position "2" (A2) is used when a new seal is fitted in service and the crankshaft flange is worn in positions "1".

Position "3" (A3) can be used with a new seal in service, if a wet clutch is not used and the crankshaft is new or the crankshaft palm area has been corrected. Ensure that the seal is fitted square in the housing.

If all positions have been used it is permissible to grind the crankshaft flange, see section 11C.

- 1 Remove the seal and housing assembly, operation 14A-02.
- 2 Put the engine side of the housing on a suitable support and press out the seal with a suitable adaptor.
- 3 Lubricate the outer circumference of the seal and the bore of the seal housing with clean engine lubricating oil.
- 4 Put the engine side of the housing on a suitable support. Put the seal into position on the flywheel end of the bore with the spring of the seal towards the housing.
- 5 Use a press and the replacer tool, PD.145D, to fit the seal at the correct depth. The special tool has two sides and is used in accordance with either position "1" or "2". Press the seal into the housing to the correct position with the relevant side of the tool.

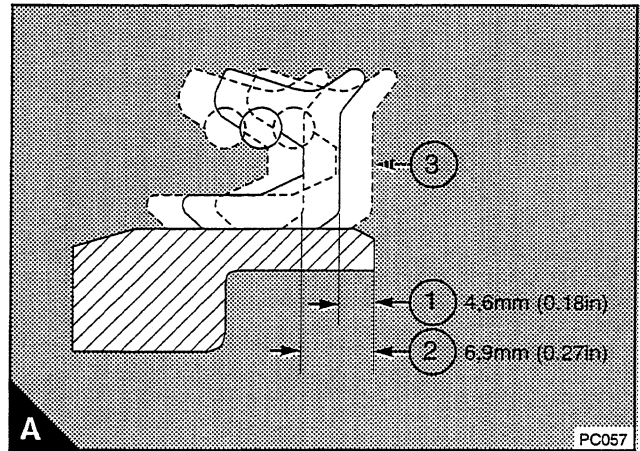

Data and dimensions

Introduction

Note: This information is given as a guide for personnel engaged on engine overhauls. The dimensions which are shown are those which are mainly used in the factory.

Crankshaft

Diameter of main journal	69,812/69,832 mm (2.7485/2.7493 in)
Width of second and third main journals	30,853/31,057 mm (1.2147/1.2227 in)
Width of fourth main journal	46,805/46,881 mm (1.8427/1.8457 in)
Fillet radii of main journal	2,39/2,77 mm (0.094/0.109 in)
Fillet radii of crank pins	3,96/4,37 mm (0.156/1.172 in)
Diameter of crank pins	51,110/57,130 mm (2.2484/2.2492 in)
Width of crank pins	39,67/39,75 mm (1.562/1.565 in)
Crankshaft end-float	0,05/0,38 mm (0.002/0.015 in)
Maximum permissible end-float	0,50 mm (0.020 in)
Maximum permissible wear on main journals and crank pins	0,038 mm (0.0015 in)
Undersizes journals and crank pins	- 0,25 mm (0.010 in)
.....	- 0,51 mm (0.020 in)
.....	- 0,76 mm (0.030 in)

Main bearings

Type	Steel back, aluminium tin face
Width of first bearing	32,11/32,36 mm (1.264/1.274 in)
Width of second and third bearing	23,55/23,80 mm (0.927/0.937 in)
Width of fourth bearing	38,91/39,17 mm (1.532/1.542 in)
Thickness at centre of bearing	2,096/2,102 mm (0.0825/0.0828 in)
Inside diameter	69,875/69,914 mm (2.7510/2.7525 in)
Bearing clearance	0,043/0,102 mm (0.0017/0.0040 in)
Available undersizes bearings	- 0,25 mm (0.010 in)
.....	- 0,51 mm (0.020 in)
.....	- 0,76 mm (0.030 in)

Crankshaft thrust washers

Type	Steel back, aluminium tin face
Position	Each side of rear main bearing
Thickness:	
- standard	3,07/3,12 mm (0.121/0.123 in)
- oversize	3,26/3,31 mm (0.128/0.130 in)

Camshaft gear

To remove and to fit

15A-05**To remove**

- 1 Remove the timing case cover, operation 15A-01.
- 2 Rotate the crankshaft until the marked teeth (A) of the crankshaft gear, the camshaft gear and the fuel pump gear are all in mesh with the idler gear. The marked teeth of the idler gear will not necessarily be in mesh with the marked teeth of the other gears because of the different speed of rotation of the idler gear.
- 3 Remove the three setscrews which retain the gear to the camshaft.
- 4 Remove camshaft gear (B) from camshaft.
- 5 Inspect the gear for wear and any other damage and renew it, if necessary.

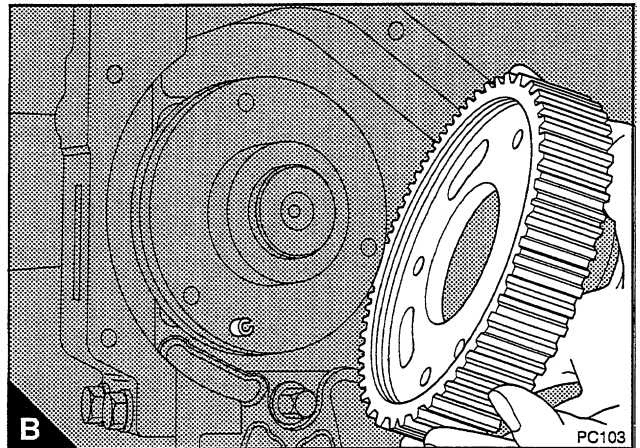
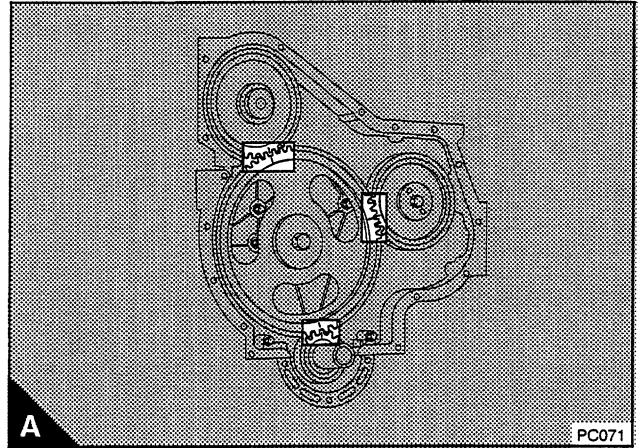

Cylinder block

To dismantle and to assemble **16A-01**

Consumable products:

POWERPART Nutlock

POWERPART Hylosil

To dismantle

- 1 Drain the cooling system. Drain the lubricating oil.
- 2 Remove the engine from the vehicle or machine.
- 3 Remove the alternator drive belt, the alternator and its mounting brackets, see section 23.
- 4 Remove the fan, and the water pump, see section 21.
- 5 Remove the fuel filter, the atomisers and the fuel injection pump, see section 20.
- 6 Remove the fuel lift pump, operation 20A-03.
- 7 Remove the lubricating oil filter assembly and the lubricating oil sump, see section 19.
- 8 Remove the lubricating oil pump, see section 19.
- 9 Remove the starter motor, operation 23B-01.
- 10 Remove the cylinder head assembly, operation 12A-07.
- 11 Remove the timing case and the timing gears, see section 15.
- 12 Remove the piston and connecting rod assemblies, operation 13A-04.
- 13 Remove the camshaft, operation 15A-09.
- 14 Remove the flywheel and the flywheel housing, see section 22.
- 15 Remove the rear oil seal assembly and the crankshaft, see section 14.
- 16 Inspect the cylinder block, operation 16A-02

Aspiration system

18

Engine breather system

18A-01	To renew the engine breather valve	18A.02
--------	--	--------

Lubricating oil pump

To remove and to fit

19A-06

To remove

Warning! Discard the used lubricating oil in a safe place and in accordance with local regulations.

- 1 Remove the drive belt, operation 23A-03. Remove the crankshaft pulley, operation 14A-01.
- 2 Drain the lubricating oil and remove the lubricating oil sump, operation 19A-03.
- 3 Remove the suction pipe and strainer, operation 19A-04.
- 4 Remove the delivery pipe (A1) of the oil pump.
- 5 Remove the timing case cover, operation 15A-01.
- 6 Remove the bridge piece of the timing case, see operation 15A-07.
- 7 Release the circlip (A4) which retains the idler gear (A3) of the oil pump and remove the idler gear. The lubricating oil pump gear must not be removed as this can reduce the interference fit of the gear. A pump which is worn cannot be corrected as separate parts are not available.
- 8 Release the setscrews (A5) and remove the oil pump (A2).

To fit

- 1 Check that the backplate (B1) of the oil pump is secure. Fill the oil pump with clean engine lubricating oil. Ensure that the recess (B2) for the idler shaft (B3) is clean. Fit the oil pump to the main bearing cap and tighten the setscrews (A5) to 22 Nm (16 lbf ft) 2,2 kgf m. Loosely fit the delivery pipe (A1).
- 2 Check the idler gear (A2) and the bush (A3) for wear and other damage. If the gear and/or the bush are damaged, they can be renewed as an assembly or the bush can be renewed as a single item. Check the shaft for the idler gear for wear or other damage. If the shaft is worn or damaged, see "To renew the idler shaft of the oil pump" paragraph 10.

Continued

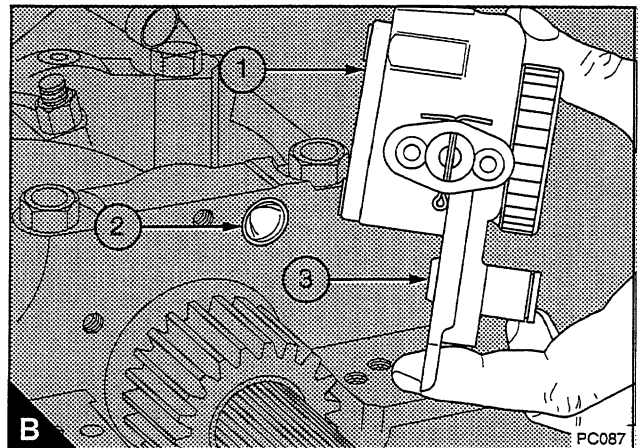
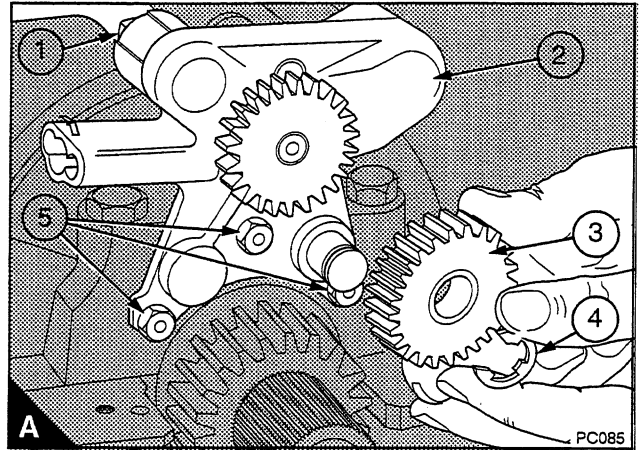

To remove and to fit

20A-02

Caution: Do not allow dirt to enter the fuel system. Before a connection is disconnected, clean thoroughly the area around the connection. After a component has been disconnected, fit a suitable cover to all open connections.

- 1 Remove the fuel leak-off pipe.
- 2 Remove the union nuts of the high-pressure pipe from the atomiser and from the fuel injection pump. Do not bend the pipe. If necessary, remove the pipe clamps.
- 3 Release the clamp setscrew (A1) of the atomiser. Remove the clamp (A3). Remove the atomiser (A5) and its seat washer (A6).
- 4 Check the clamp for damage and, if necessary, renew the clamp. Renew the atomiser seat washer and the dust seal (A4).
- 5 Put the new atomiser and seat washer into position with the leak-off connection (A2) towards the rear of the engine. Ensure that the atomiser is not tilted and fit the clamp with the arms of the clamp fitted squarely on the shoulders of the atomiser. Tighten the clamp setscrew to 22 Nm (16 lbf ft) 2,2 kgf m.

Caution: Do not tighten the union nuts of the high-pressure pipes more than the recommended torque tension. If there is a leakage from the union nut, ensure that the pipe is correctly aligned with the atomiser inlet. Do not tighten the atomiser union nut more, as this can cause a restriction at the end of the pipe. This can affect the fuel delivery.

- 6 Fit the high-pressure fuel pipe and tighten the union nuts to 22 Nm (16 lbf ft) 2,2 kgf m. If necessary, fit the pipe clamps.
- 7 Renew the sealing washers and fit the leak-off pipe. Tighten the banjo bolt to 9,5 Nm (7,0 lbf ft) 1,0 kgf m.
- 8 Operate the engine and check for leakage of fuel and air.

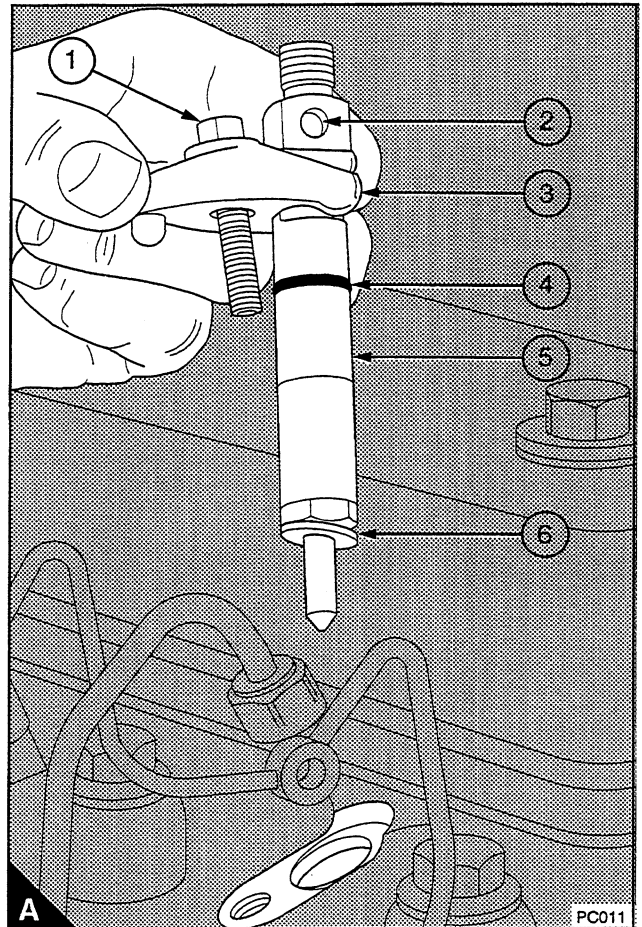

Cooling system **21****General description** 21A.02**Thermostat**

21A-01 To remove, to fit and to test 21A.04

Coolant pump

21A-02 To remove and to fit 21A.05

21A-03 To dismantle and to assemble 21A.07

Fan

21A-04 To remove and to fit 21A.10

Data and dimensions 21A.11

Data and dimensions

Introduction

Note: This information is given as a guide for personnel engaged on engine overhauls. The dimensions which are shown are those which are mainly used in the factory.

Cooling system

Type Thermostat controlled - pump assistance

Water pump

Type Centrifugal, belt driven
 Diameter of shaft 15,905/15,918 mm (0.6262/0.6267 in)
 Diameter of bore in pulley 15,847/15,867 mm (0.6239/0.6247 in)
 Interference fit of pulley on shaft -0,038/-0,071 mm (-0.0015/-0.0028 in)
 Diameter of bore in impeller 15,872/15,893 mm (0.6250/0.6257 in)
 Interference fit of impeller on shaft 0,012/0,046 mm (0.0005/0.018 in)
 Interference fit of water seal in body -0,005/0,281 mm (-0.0002/-0.0111 in)
 Interference fit of water seal on shaft -0,047/-0,136 mm (-0.0019/-0.0054 in)
 Clearance between impeller blades and pump body 0,25/0,50 mm (0.010/0.020 in)
 Dimension, pulley face for fan to rear face of pump body 114,3 mm (4.5 in)

Thermostat

Type wax
 "Starts to open" temperature 80/84°C (176/183°F)
 "Fully open" temperature 96°C (205°F)
 Valve lift:
 - starts to open 0,2 mm (0.008 in)
 - fully open 9,0 mm (0.350 in)

Drive belts**To check****23A-01**

- 1 Renew the belt if it is worn or damaged.
- 2 The condition of the belt should be checked at the intervals shown on page 4.03 in the User's Handbook. The belt should be renewed if there are cracks in the belt or if the belt is contaminated by oil or grease.
- 3 To check the tension, press the belt with the thumb (A) at the centre of the longest free length and check the deflection. With moderate thumb pressure 45 N (10 lbf) 4,5 kgf the correct deflection of the belt is 10 mm (3/8 in).

To adjust tension**23A-02**

- 1 Loosen the pivot fasteners (A2) of the alternator and the fasteners of the adjustment link (A1).
- 2 Change the position of the alternator to give the correct tension. Tighten the adjustment link fasteners and then the pivot link fasteners.
- 3 Check the belt tension again to ensure that it is still correct.

Note: If a new belt is fitted, the belt tension must be checked again after the first 25 hours of operation.

To remove and to fit**23A-03**

- 1 Loosen the pivot fasteners (A2) of the alternator and the adjustment link fasteners (A1). Ensure that the spacer between the link fastener and the timing case is not lost.
- 2 Release all of the tension from the belt and remove the belt.
- 3 Fit the new belt and adjust the tension, operation 23A-02.

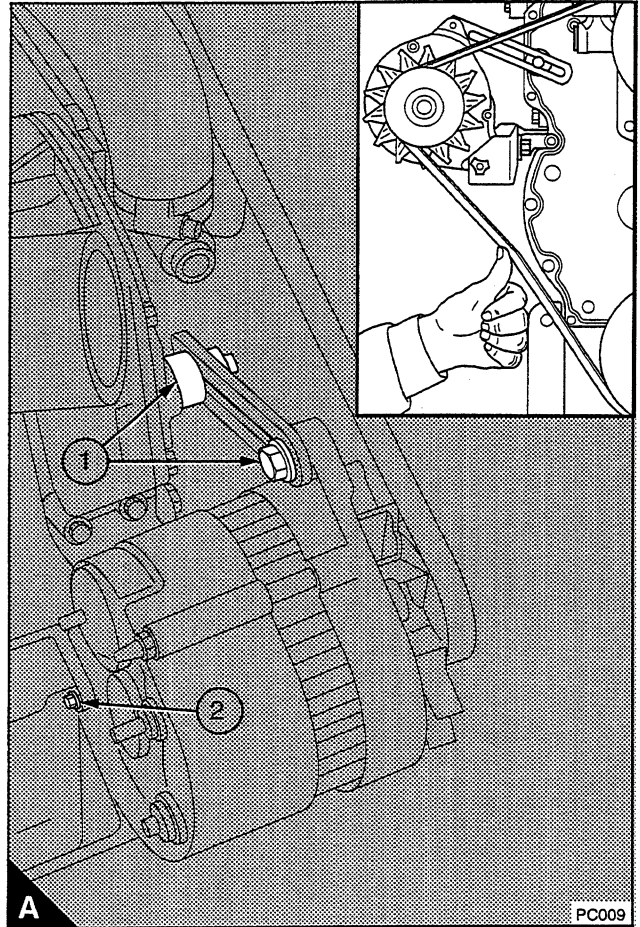

CLICK HERE TO **DOWNLOAD** THE COMPLETE MANUAL

- Thank you very much for reading the preview of the manual.
- You can download the complete manual from: www.heydownloads.com by clicking the link below



- Please note: If there is no response to CLICKING the link, please download this PDF first and then click on it.

CLICK HERE TO **DOWNLOAD** THE COMPLETE MANUAL

Technical data



Introduction

Note: This information is given as a guide for personnel engaged on engine overhauls. The dimensions which are shown are those which are mainly used in the factory.

Electrical equipment

Starter motor

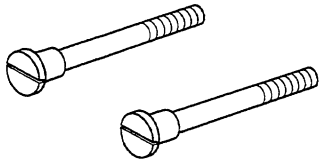
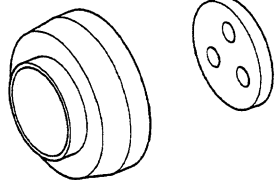
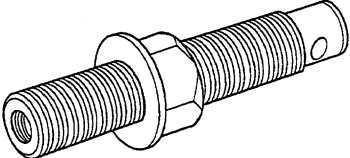
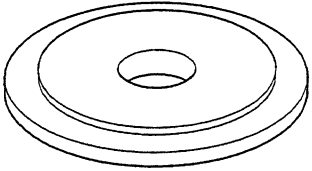
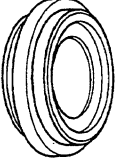
Make	Magneti Marelli M127
Voltage	12V
Number of teeth on pinion	10
Maximum starter cable resistance at 20°C (68°F)	0.0012 ohm

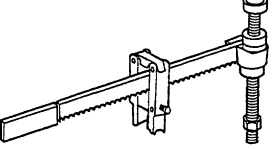
Number	Description	Illustration
PD.155B-5	Adaptors for use with PD.155C. Part number 21825568	
PD.162B	Centralising tool for timing case cover. Part number 21825571	
PD.170	Replacer tool for seal of timing case cover (main tool). Part number 21825577	
PD.170-1	Pressure plate for use with PD.170. Part number 21825578	
PD.170-4	Adaptor for use with PD.170. Part number 21825582	
PD.208	Dial gauge for use with PD.41D. Part number 21825617	
PD.6118B	Valve spring compressor. Part number 21825666	

GROUPS 55

ARMS - PLATFORM

F - REMOVING THE TELESCOPE

- Wedge the basket.
- Hold back the mobile tube with a rope.
- Remove the telescope cylinder (see removing the telescope cylinder).
- Dismantle the head axle 1 (Fig. F1) of the tilt cylinder (12 mm wrench).
- Démontez l'axe de l'articulation 2 (Fig. F1) of the pendular (12 mm wrench and circlip pliers).
- Dismantle the tilt cylinder 3 (Fig. F2).
- Dismantle the hose trough 4 (Fig. F1) (3 screws, 10 mm wrench).
- Pull out the hoses.
- Dismantle the two closing covers 5 (Fig. F4) (8 screws, 10 mm wrench).
- Dismantle the chain 6 (Fig. F3) (2 screws, 4 mm hexagonal wrench).
- Dismantle the chain housing 7 (Fig. F3) (10 mm wrench).
- Dismantle the jib head upper pad 8 (Fig. F4) (13 mm wrench, 4 mm hexagonal wrench)
- Dismantle the jib head lower pad 9 (Fig. F4) (19 mm wrench, 6 mm hexagonal wrench)
- Remove the telescope mobile tube 10 (Fig. F3).

F1

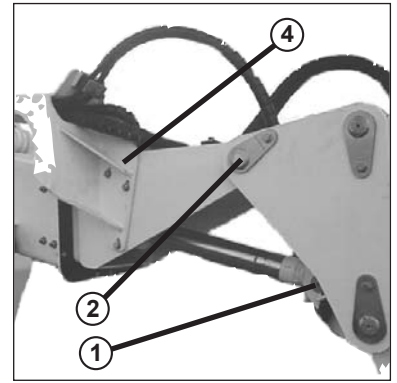

F2

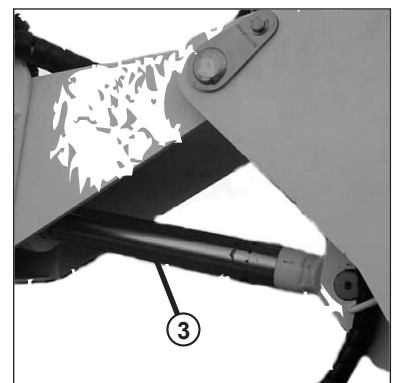

F3

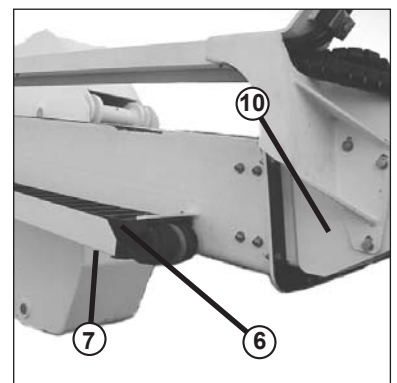

F4

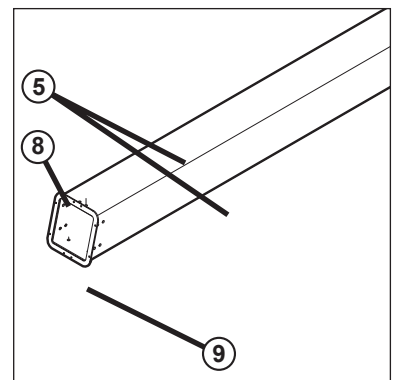

REASSEMBLY

- Carry out the operations described above in the reverse order.

REMOVING THE BASKET ROTATION ENGINE

- Locate the basket rotation engine hoses.
- Dismantle the ring gear case 1 (Fig. A)(3 screws, 10 mm wrench).
- Dismantle the two hydraulic hoses 2 (Fig. A) (19 mm wrench).
- Dismantle the two mounting screws 3 (Fig. A) of the engine (10 mm hex. wrench).
- Remove the engine 4 (Fig. A).

Nota : tightening torque of mountig screws 3 : $8 \pm 10\%$ daN.m

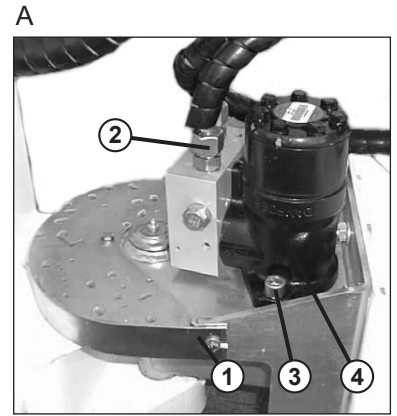

REMOVING THE TURRET ROTATION ENGINE

- Position the platform in such a way as to gain access to the turret rotation engine.
- Disassemble the inner turret casing (4 screws, 10 mm wrench).
- Locate the hoses.
- Disassemble the lower turret polyester casing (7 screws, 10 mm wrench).
- Disassemble the two hydraulic hoses 5 (Fig. B) (19 mm wrench, 24 mm wrench).
- Disassemble from these two ends the hydraulic hose 6 (Fig. B) (19 mm wrench).
- Disassemble the two engine mounting screws 7 (Fig. B) (8 mm hexagonal wrench height 40).
- Remove the engine 8 (Fig. B).

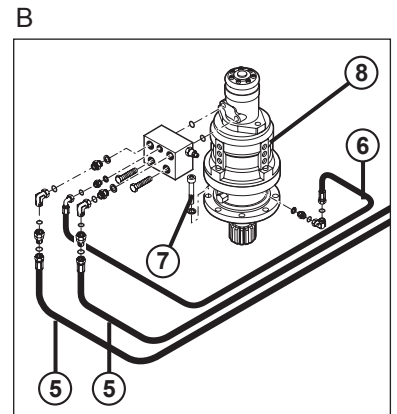

When remounting the engine, use two new mounting screws 7 (Fig. B)
(qualité 12.9) with average locking compound.
(tightening torque : $13.5 \pm 10\%$ daN.m)

REMOVING THE TILT CYLINDER

- Locate the hydraulic hoses.
- Wedge the basket with a hoisting device (lift as much as possible).
- Dismantle the locking axles 1 (Fig. A and B)(13 mm wrench, circlip pliers).
- Remove the cylinder.
- Disconnect the hydraulic hoses (19 mm wrench) and seal them.

REASSEMBLY

- Carry out the operations described above in the reverse order.

A

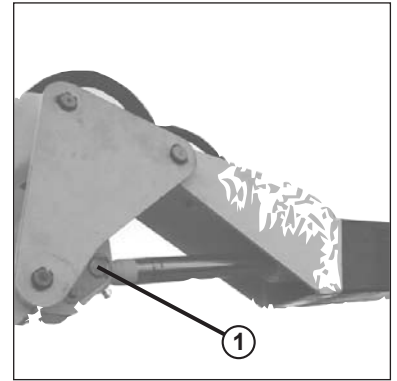

B

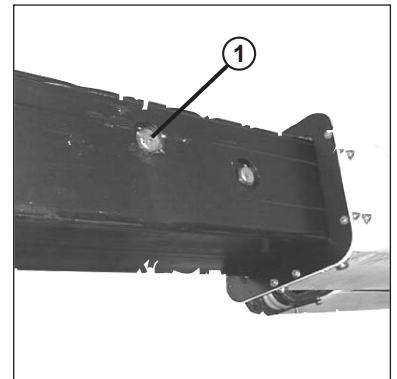

**REMOVING THE AXLE LOCKING CYLINDER
(OSCILLATION)
165ATJ
70-2-70-M.53 EN**

All the pressures are adjusted between 25 et 30°C

- Remove the turret right cowling.

MAIN CIRCUIT (240 BARS)

- Required tooling

- 1 pressure gauge (0-400 bar)549885
- 1 test hose549887

- Connect the pressure gauge onto the pressure tapping point 1 (Fig. A).
- Lower the lower arm as much as possible.
- Read the pressure on the pressure gauge.
- Main circuit pressure = 240 bar.
- If necessary, act upon the pressure limiter 2 (Fig. A) with a 1/4 mm hex. wrench (adjusting screw) after having removed the plug.

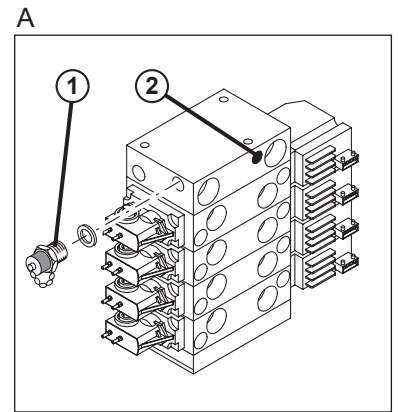

50% SLOPE OPTION

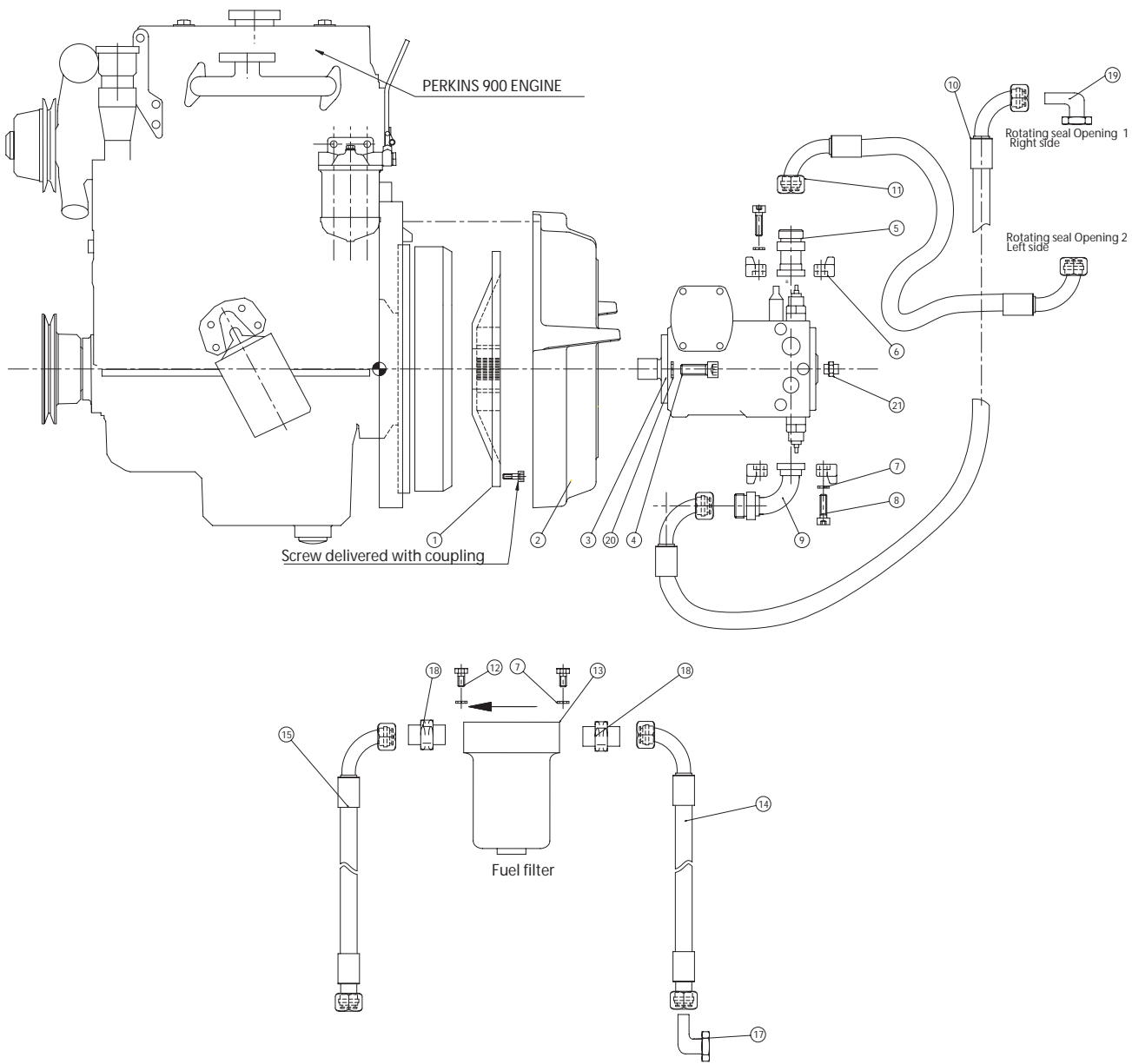

Reparaturanleitung / Repair instructions
A10VG ... 28-63 Baureihe/Series 10

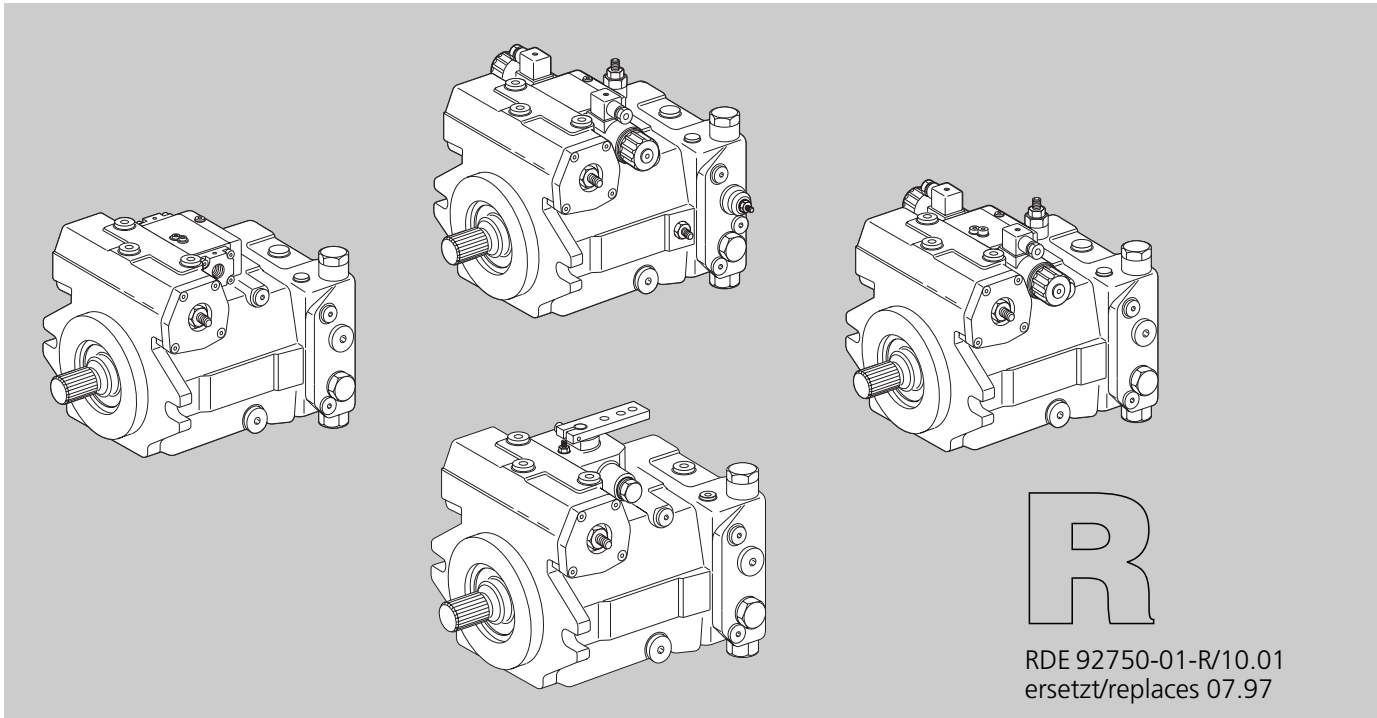

Mobile Hydraulics

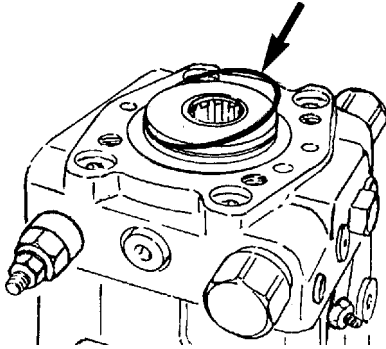

O-Ring ausbauen.

Remove O-ring.

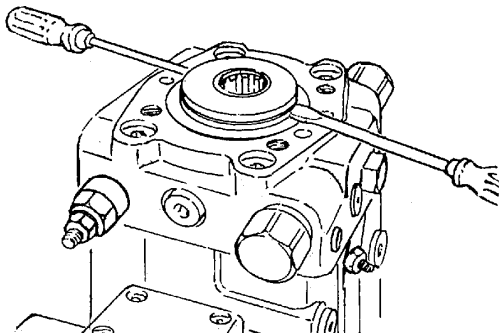

Hilfspumpe abdrücken.

Pry off the boost pump.

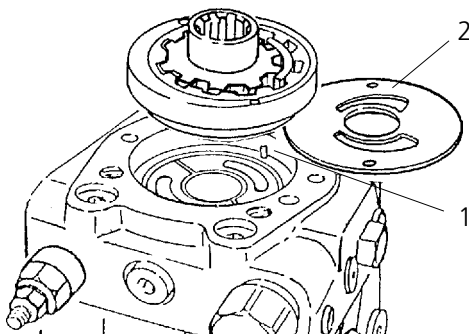

1. Verschleißplatte

2. Fixierstift

1. Wear plate

2. Locating pin

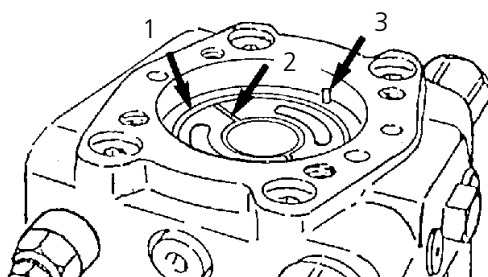

1. Kantsil-Ring

2. Entlastungsnut

3. Fixierstift

1. Kantsil-ring

2. Unloading channel

3. Locating pin

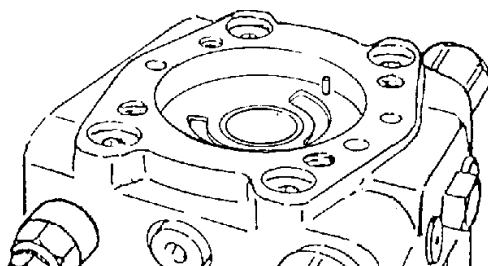

Verschleißplatte einsetzen.

Drehrichtung beachten!

Fit wear plate taking the direction of rotation account.

- * Markierung Montageposition **HD**
- * Marking the assembly position HD

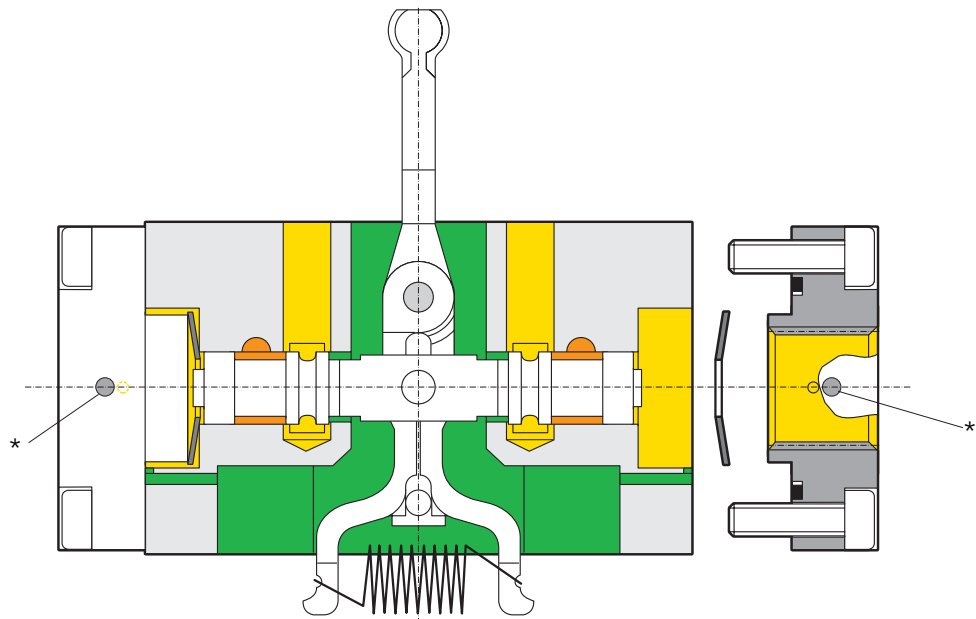
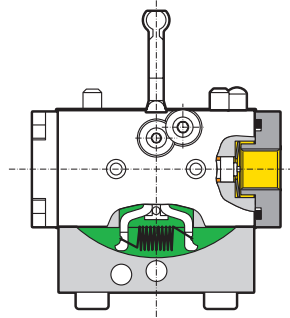
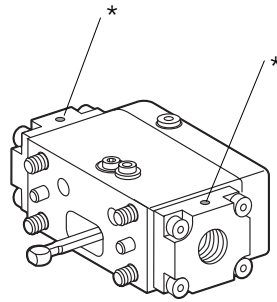

- * Markierung
Montageposition **HD**

- * Assembly position marker **HD**

Wird von EP- auf HD-Ausführung umgebaut -
Deckelposition beachten siehe Markierung

- Leckölkanal offen wird geschlossen.

 Zugfeder tauschen!

Is converted from EP into the HD version -
take note of the cover position, see marker

- The open leakage port is plugged

 Exchange the tension spring!

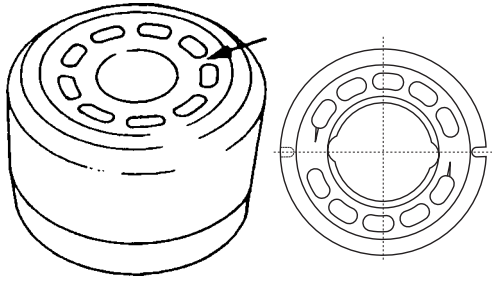

Kontrolle!
Zylindergleitfläche (1) riefenfrei, nicht eingelaufen, keine Einlagerungen, Steuerplatte (2) nicht riefig (nur satzweise austauschen).

Check!
Cylinder sliding surface (1) free of grooves, no wear, no embedded foreign particles. That there are no scratches on the control plate (2). (Only replace them as a set).

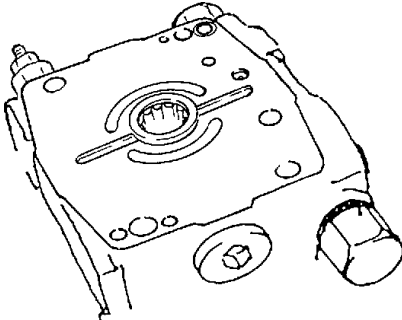

Kontrolle!
Auflagefläche - Steuerplatte ohne Beschädigung.

Check!
Mounting surface - control plate undamaged

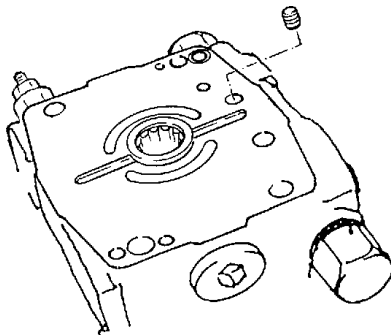

Hinweis:
Bohrung bei DA-Regelung offen. (gültig nur bei A10VG 45).

Information:
Hole for DA-control is open, without DA control valve it is plugged.

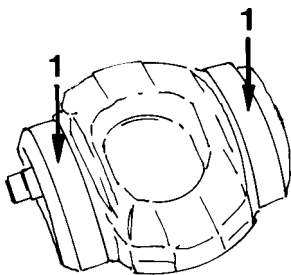

Kontrolle!
Lagerbahnen (1)

Check!
Bearing surfaces (1)

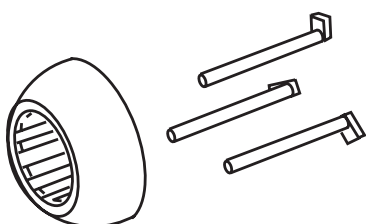

Riefenfrei, keine Einlaufspuren

Free of grooves, no wear.

2. Verschlußschrauben mit Innensechskant und Profildichtung (nach N 02.009).

2. Plugs with internal hexagon and profile seal ring (to N 02.009).

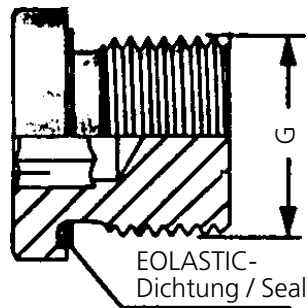

Gewinde / Thread	Anziehdrehmoment / Tightening torque M_A in Nm	Gewinde / Thread	Anziehdrehmoment Tightening torque M_A in Nm
M8 x 1	5	G 1/8 A	10
M10 x 1	10	G 1/4 A	30
M12 x 1,5	20	G 3/8 A	35
M14 x 1,5	30	G 1/2 A	60
M16 x 1,5	35	G 3/4 A	90
M18 x 1,5	40	G 1 A	140
M20 x 1,5	50	G 1 1/4 A	240
M22 x 1,5	60	G 1 1/2 A	300
M26 x 1,5	70		
M27 x 2	90		
M30 x 1,5	100		
M33 x 2	140		
M42 x 2	240		
M48 x 2	300		

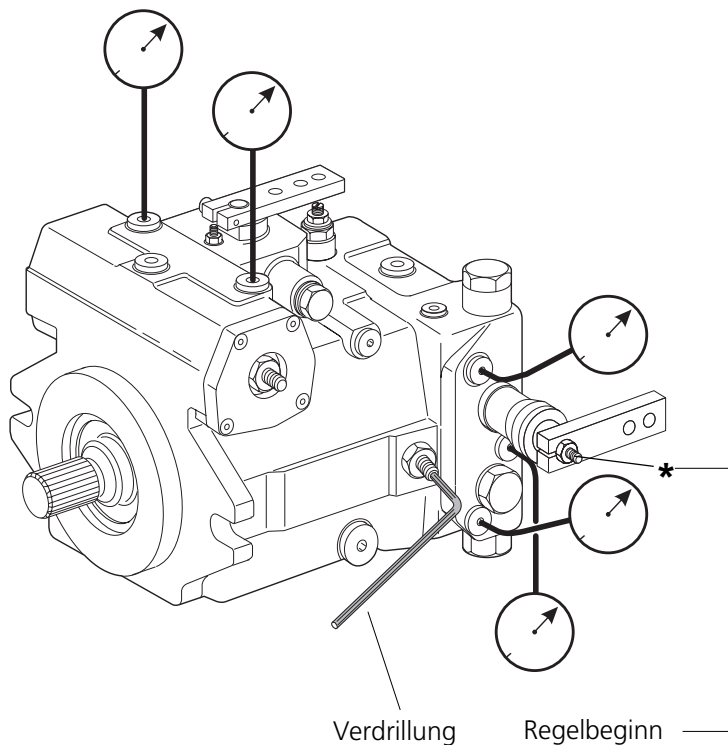

Achtung!
Sicherheitsbestimmungen beachten!

Überprüfung der Einstelldaten
Betriebstemperatur soll während des Überprüfungsprozesses weitgehend konstant gehalten werden.
Antriebsmotor starten, Leerlaufdrehzahl

Blockzustand

Fahrrichtungsschalter "0"
Motordrehzahl langsam steigern bis zur max.
Motordrehzahl, dabei Meßgeräte beobachten.
Speisedruck:
Leerlaufdrehzahl
Psp = ca. 15-20 bar
max. Motordrehzahl
Psp = bar*

Blockzustand

Fahrrichtungsschalter - vorwärts
(Straßengang und Festgebremst)

Einstelldaten Pumpe A4V/DA überprüfen

*** Regelbeginn**

HD 40 - 50 bar
Motordrehzahl . min.¹ * Psp bar*
HD bar
Nachjustierung - Regelbeginnschraube

Regelende

HD bar*
Motordrehzahl min.¹ * Psp bar*
Nachjustierung - Verdrillschraube

Hinweis:
Excenterjustierung - Drehrichtung beachten

Hinweis: * Einstelldaten nach Werksauftrag!

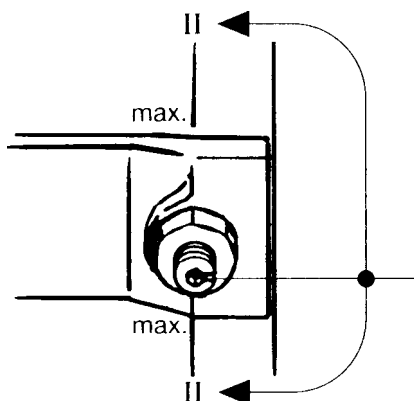

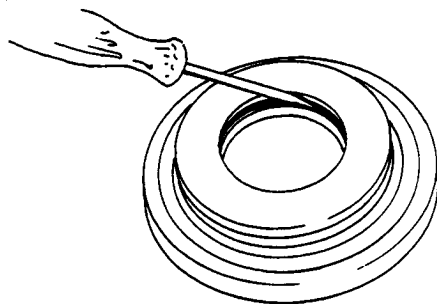

Wellendichtring demontieren.

Remove shaft seal.

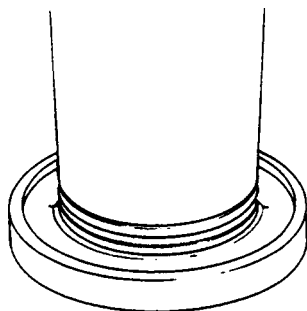

Neuen Wellendichtring lagerichtig mit passender Büchse einpressen.

Press in the new shaft seal, ensuring that it is correctly orientated, using a suitable bush.

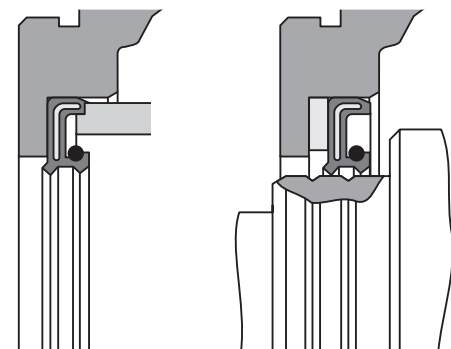

Bei tiefer Laufrille Scheibe vor den Wellendichtring einlegen (max. 1 mm).

If the drive shaft is deeply grooved, insert a shim in front of the shaft seal (max. 1 mm).

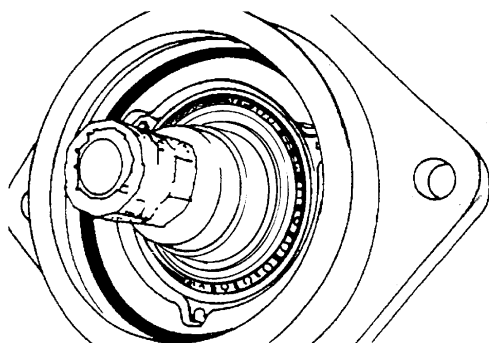

Neuen O-Ring einlegen, auf bündiges Anliegen achten. O-Ring sowie *Dicht- und Staublippe* des Wellendichtringes einfetten. (siehe Serviceinfo)

Fit new O-ring, ensure that it is correctly located. *Grease the O-ring as well as the seal and dust lips of the shaft seal.* (see service information)

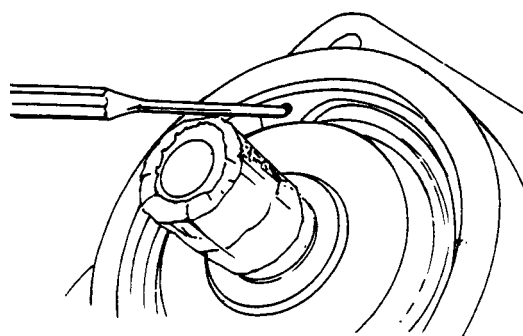

Sicherungsring einbauen.
Sitzkontrolle des Sicherungsringes in der Nut.

Fit circlip.
Check to ensure that the circlip is correctly located within the groove.

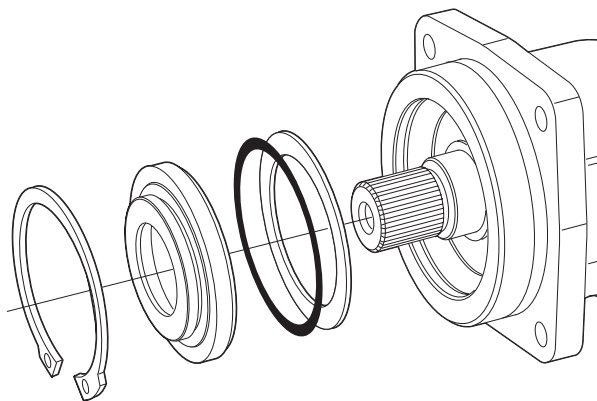

Paßscheibe, O-Ring einlegen. Verschußring montieren.

⚠ O-Ring, Zwischenraum Wellendicht-
ring einfetten (siehe Serviceinfo).

⚠ Fit the shim and O-ring. Then fit the cover.
Grease the O-ring as well as the seal
and dust lip of the shaft seal.

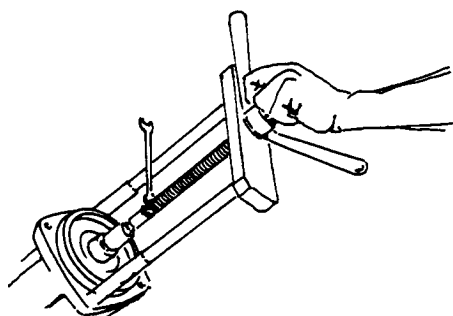

Triebwerk gegen Verschußring ziehen.
Kontrolle: Verschußring spielfrei.

Pull the rotary group against the cover.
Check: to see that the cover is free of play.

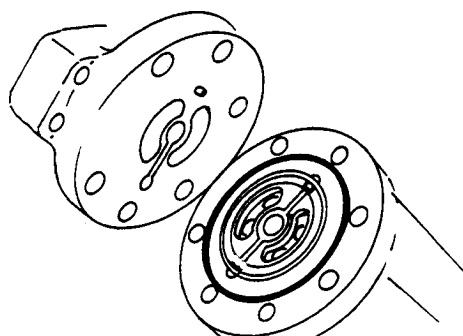

Befestigungsschraube ausbauen.
Steuerplatte lagerichtig aufsetzen.
Fertigmontage

⚠ Abstimmung Pos. D - siehe Serviceinfo

Remove fixing screw. Fit the control plate
into its correct location.
Final assembly

⚠ For adjustment of Pos. D - see service info

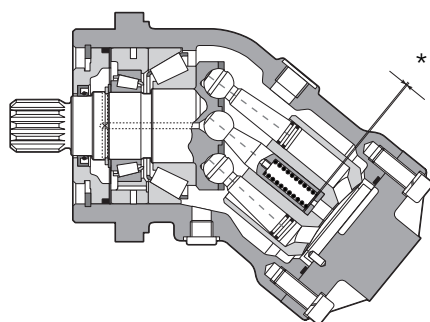

* Pos. D

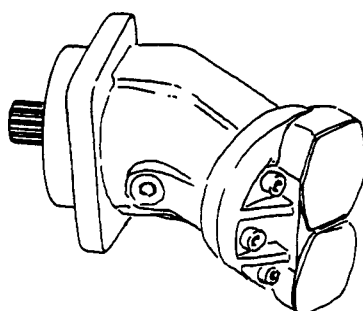

Anschlüsse mit Staubschutz abdichten.
Korrosionsschutz (innen/außen). Fertig!

Seal connections to protect against dust.
Corrosion protection (internal/external).
Assembly complete.

***REPLACING THE ELECTRONIC
BASEBOARD AND MICROPROCESSOR
165ATJ
80-2-10-M.53 EN***

MAIN ELECTRICITY CABINET

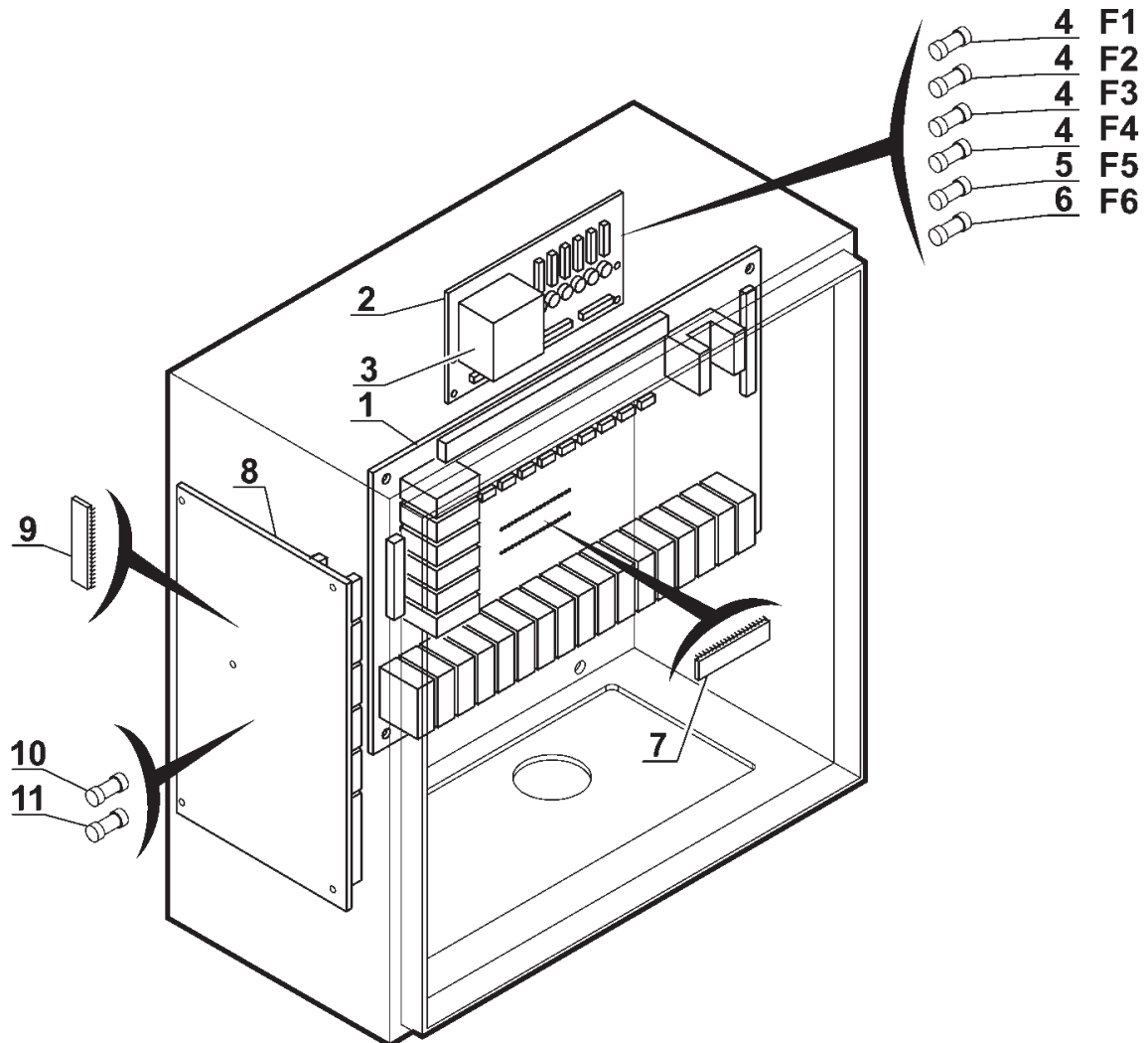

Card1 (mark 1) : On/off component control card. It includes 25 logical inputs with LED display (marked from A to Y) and 23 mechanical relay outputs with LED display (R1 to R23). A programm microcontroller (mark 7) ensures logical operation (programm version MAN X.X). A flashing "RUN" LED indicates that the card is operating correctly.

Card 2 (mark 8) : Proportional component control card. It handles 4 proportional electrovalves (hydrostatic pump and DANFOSS PVG 32 electrovalve) and the manipulator. It includes 24 logical inputs and 12 mechanical outputs. The card is protected by 1 fuse (mark 10). Electronic is protected by 1 fuse. EPROM type memory (mark 9) ensures logical operation (programm version CIMM VX). A flashing "RUN" LED indicates that the card is operating correctly.

Card 3 (mark 2) : Fuse card. Card 1 (inputs and outputs) is protected by 6 fuses. The card also includes the starter motor relay (mark3).

LEDS STATE TABLE PER POSSIBLE MOVEMENT Ref. MICRO W.517700-007

CAVAGE TILTING ELECTROVALVE

Input CI Movement	A	B	C	D	E	F	G	H	I	J	K	L	M	N	O	P	Q	R	S	T	U	V	W	X	Y
<i>Base Control</i>	X	X	X	X	X	X	X	X	X	X	0	0	X	0	1	X	X	X	X	X	X	0	0	0	X
<i>Basket Control</i>	1	X	X	X	X	X	X	X	X	X	0	0	X	0	1	0	0	X	0	0	X	1	0	0	X

Output CI Movement	R1	R2	R3	R4	R5	R6	R7	R8	R9	R10	R11	R12	R13	R14	R15	R16	R17	R18	R19	R20	R21	
<i>Cavage tilting EV</i>	X	X	X	X	X	X	1	X	X	X	X	X	X	X	X	X	X	X	X	X	X	X

0 = Plate led switched off in order to have the movement
 1 = Plate led switched on in order to have the movement
 X = No taking into account of the state0-1 in order to have the movement

LEDS STATE TABLE PER POSSIBLE MOVEMENT Ref. MICRO W.517700-007

MAXI ENGINE SPEED ELECTROVALVE

Input CI Movement	A	B	C	D	E	F	G	H	I	J	K	L	M	N	O	P	Q	R	S	T	U	V	W	X	Y
<i>Basket control</i>	X	X	X	X	1	1	X	0	X	X	X	X	X	X	X	X	X	X	X	X	X	1	X	X	X
	X	X	X	X	1	X	X	0	1	X	X	X	X	X	X	X	X	X	X	X	X	1	X	X	X
	X	X	X	X	X	1	X	0	1	X	X	X	X	X	X	X	X	X	X	X	X	1	X	X	X
	X	1	1	X	X	X	X	1	X	X	X	X	X	X	X	X	X	1	X	X	X	1	X	X	X

Output CI Movement	R1	R2	R3	R4	R5	R6	R7	R8	R9	R10	R11	R12	R13	R14	R15	R16	R17	R18	R19	R20	R21	
<i>Maxi engine speed EV</i>	X	X	X	X	X	X	X	X	X	X	X	X	X	X	X	X	X	X	X	1	X	X

0 = Plate led switched off in order to have the movement
 1 = Plate led switched on in order to have the movement
 X = No taking into account of the state0-1 in order to have the movement

CLICK HERE TO **DOWNLOAD** THE COMPLETE MANUAL

- Thank you very much for reading the preview of the manual.
- You can download the complete manual from: www.heydownloads.com by clicking the link below



- Please note: If there is no response to CLICKING the link, please download this PDF first and then click on it.

CLICK HERE TO **DOWNLOAD** THE COMPLETE MANUAL