

# Repair Manual

## MAN Industrial Diesel Engines

### D2862 LE131-138

**MAN Engines**  
A Division of MAN Truck & Bus



CLICK HERE TO **DOWNLOAD** THE COMPLETE MANUAL

- Thank you very much for reading the preview of the manual.
- You can download the complete manual from: [www.heydownloads.com](http://www.heydownloads.com) by clicking the link below



- Please note: If there is no response to CLICKING the link, please download this PDF first and then click on it.

CLICK HERE TO **DOWNLOAD** THE COMPLETE MANUAL

## 2.1 Explanation of icons

### Warnings

Warnings in this guide are identified by icons. The information has been introduced with signal words that express the extent of risk or danger.

Follow the instructions in all cases and proceed with care in order to prevent accidents, personal injury and material damage.

#### **⚠ DANGER**

**Describes an immediate dangerous situation that will lead to severe injuries or death if it is not avoided.**

For this reason:

- 

#### **⚠ WARNING**

**Describes a potentially dangerous situation that may lead to severe injuries or death if it is not avoided.**

For this reason:

- 

#### **⚠ CAUTION**

**Describes a potentially dangerous situation that may lead to minor or moderate injuries if it is not avoided.**

For this reason:

- 

#### **NOTE**

**Describes a potentially dangerous situation that may lead to damage to property if it is not avoided.**

For this reason:

- 

### Tips and Recommendations

#### **Tip for users**

Tips and recommendations as well as information for efficient and trouble-free operation.

#### **ENVIRONMENTAL NOTE**

Tips on conduct for environmental protection.

### General information

- This symbol indicates a listing at the first level.
- ▶ This symbol displays an action or series of actions.
- 1** This symbol displays the position of a graphic in the text.
- [1] This symbol displays the position of a special tool in the text.

## 2.2 General

Only personnel with the proper training are permitted to perform maintenance or repair work on the engine.

The present manual must be read and understood carefully and completely.

The instructions refer to an engine in a removed<sup>1</sup> and dry<sup>2</sup> condition.

The safety regulations of the overall system must also be observed when working on the installed engine. These are not included in the present manual.

The engine must be located on a suitable device, e.g. the assembly device of MAN Truck & Bus AG.

Observe the safety instructions. Follow the instructions to the letter and proceed cautiously to prevent accidents, personal injury and material damage. Before commencing work, ensure that the latest documentation is used.

### Connecting the charging pressure sensor electrical connection

- ▶ Restore the electrical connection **1**, pushing until the spring shackle engages
- ▶ Check that the electrical connection has engaged by pulling carefully, re-fit it if necessary
- ▶ Route the cable and secure with a cable tie
- ▶ Tighten and trim the cable ties using the cable tie pliers [1]

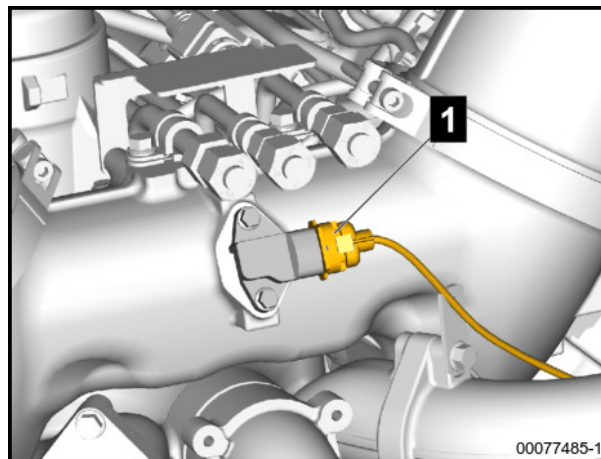

### 3.1.1.2 Removing/installing the EDC fuel temperature sensor

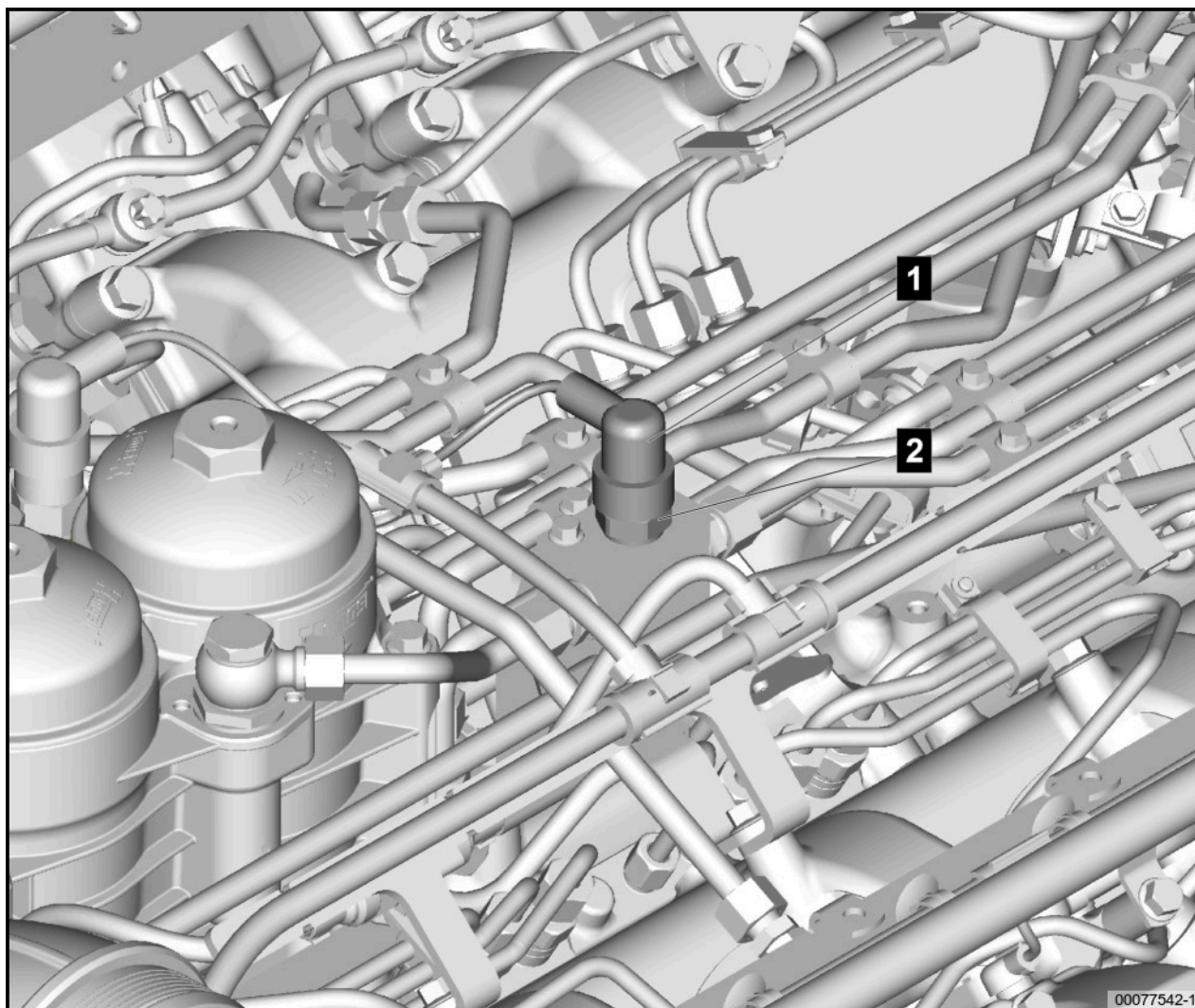

key

- 1** Fuel temperature sensor
- 2** Connect the electrical connection for the fuel temperature sensor

#### Technical data

#### Tightening torques

Fuel temperature sensor..... M16 x 1.5..... 45 +5 Nm

**Technical data****Tightening torques**

Oil pressure sensor..... M18x1.5..... 45 +5 Nm

**Important information****NOTICE****Risk of material damage from incorrectly tightened bolted connections**

Components will be damaged.

For this reason:

- Only use an impact screwdriver to tighten to max. 50% of the prescribed torque.
- Final tightening must always be performed manually using a torque wrench.

**Tip for users**

Restricted operation due to incorrect entries in the diagnostic memory

- Before removing switches or sensors, read out and document the fault memory.
- Always install switches and sensors with new O-rings or seals.
- After installing switches or sensors, read out the fault memory and delete it, if necessary.

**Special tools**

1

**Plug housing wrench**

80.99603-0418

Quantity 1

Disconnecting electrical plug connectors with bayonet catch

2

**Cable tie pliers**

08.02960-0100

Quantity 1

Tightening and cutting the cable ties

**Removing the oil pressure sensor****Disconnecting the oil pressure sensor electrical connection**

- ▶ Mark the installation position of the cable ties
- ▶ Disconnect the cable ties
- ▶ Free the cable
- ▶ Open the bayonet catch **1** using the wrench for plug housing [1]
- ▶ Disconnect the electrical connection **1**

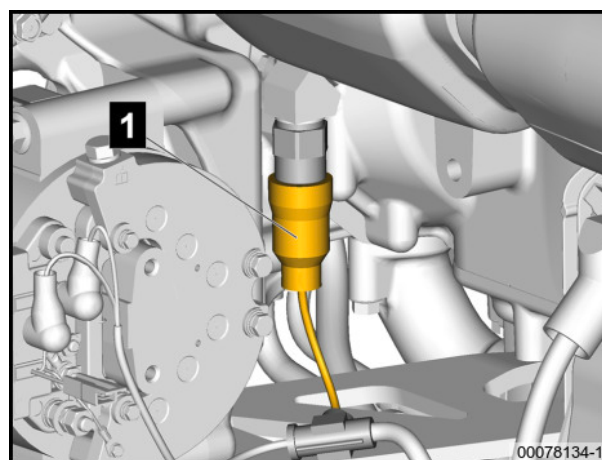

### Installing the temperature sensor

#### Installing the temperature sensor

- ▶ Screw in and tighten the connector **1** with a new sealing ring **2**

Coolant temperatureM16 x 1.5..... ..... 45 +5 Nm  
sensor.....

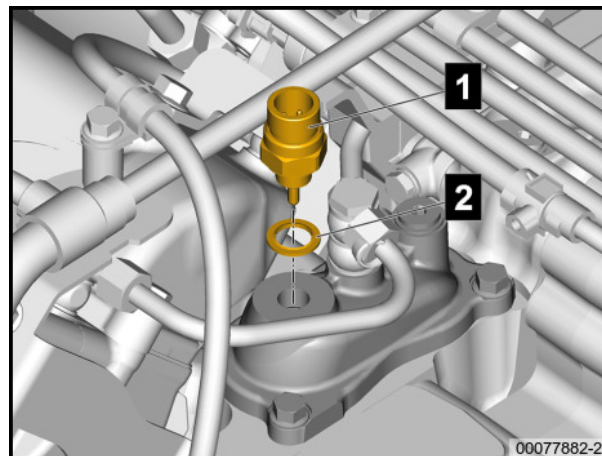

#### Connecting the temperature sensor electrical connection

- ▶ Attach the electrical connection **1** to the temperature sensor
- ▶ Close the bayonet catch **1** using the wrench for the plug housing [1]
- ▶ Route the cable and secure with a cable tie
- ▶ Tighten and trim the cable ties using the cable tie pliers [2].

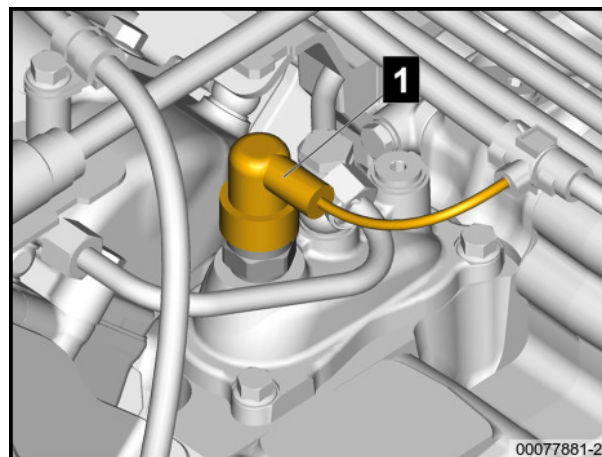

### 3.1.1.9 Removing/installing the crankshaft speed sensor

### Attaching the electrical connection for the master engine control unit

#### NOTICE

#### Risk of damage to components caused by incorrect locking

Irreparable damages to the engine control module.

For this reason:

- When installing the plug, first open the plug lock completely and then insert and lock the plug connector.

- ▶ Insert and lock the plugs **1**, **2**, **3** and **4** into the engine control unit
- ▶ Route the cable harnesses and secure using cable ties
- ▶ Tighten and trim the cable ties using the cable tie pliers [1].

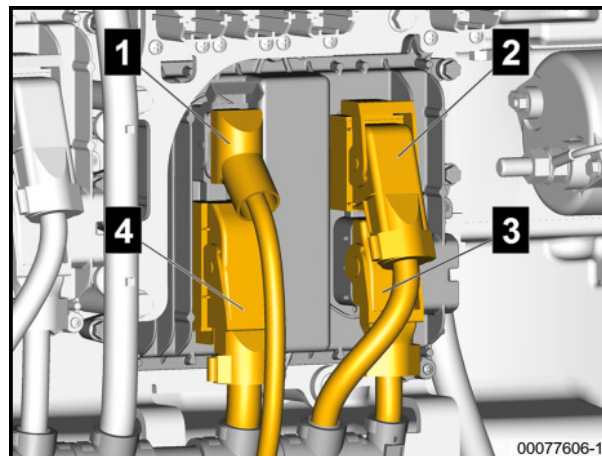

### Attaching the electrical connection for the slave engine control unit

#### NOTICE

#### Risk of damage to components caused by incorrect locking

Irreparable damages to the engine control module.

For this reason:

- When installing the plug, first open the plug lock completely and then insert and lock the plug connector.

- ▶ Insert and lock the plugs **1**, **2**, **3** and **4** into the engine control unit
- ▶ Route the cable harnesses and secure using cable ties
- ▶ Tighten and trim the cable ties using the cable tie pliers [1].

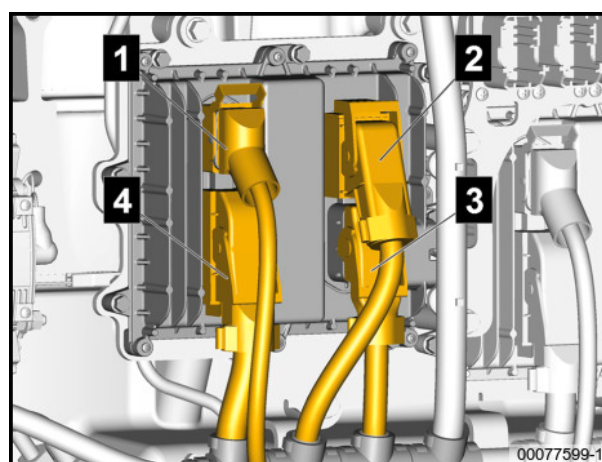

**Connecting the starter motor electrical connection**

▶ Screw on the mounting nut **3** and tighten it

Terminal 30..... M12x1..... 25 Nm

Terminal 31..... M12x1..... 25 Nm

▶ Connect the cable harness **1**

▶ Screw the mounting nuts on terminal 50 and terminal 85

Terminal 50.....M6 x 1..... 4 Nm

Terminal 85.....M6 x 1..... 4 Nm

▶ Attach the protective caps **2**

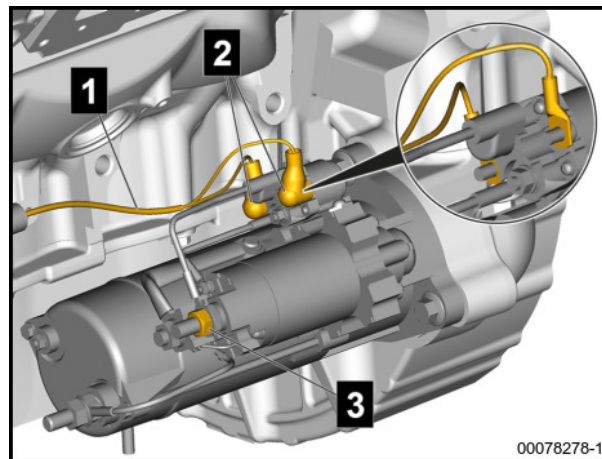

## Removing the coolant manifold on the engine block

### Detaching the coolant line from the left coolant manifold

- ▶ Loosen the retaining nuts **2**
- ▶ Remove the coolant line **1**
- ▶ Unscrew the hollow screw **3** with the sealing ring
- ▶ Remove the coolant line **4**

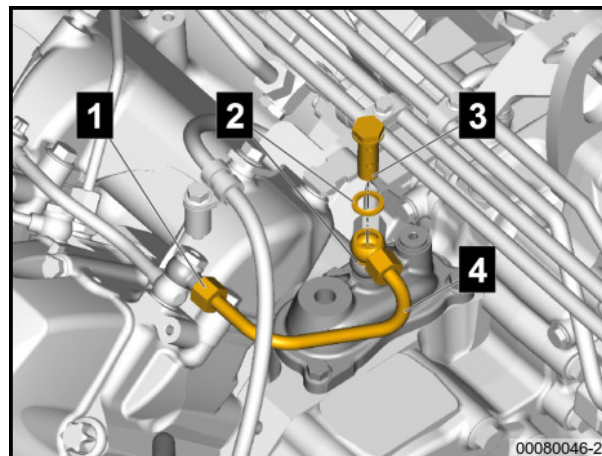

### Detaching the coolant line

- ▶ Loosen the retaining nuts **2**
- ▶ Remove the coolant line **1** with new sealing ring from the coolant manifold **3**

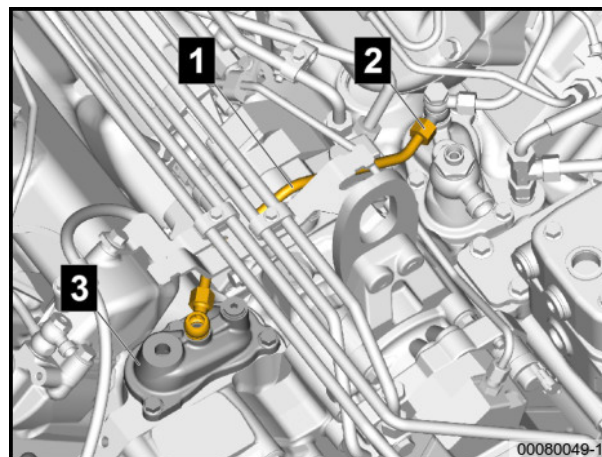

### Detaching the coolant manifold

- ▶ Unscrew the mounting bolts **1**
- ▶ Remove the coolant manifold **2** with O-rings **3**
- ▶ Clean the sealing surfaces

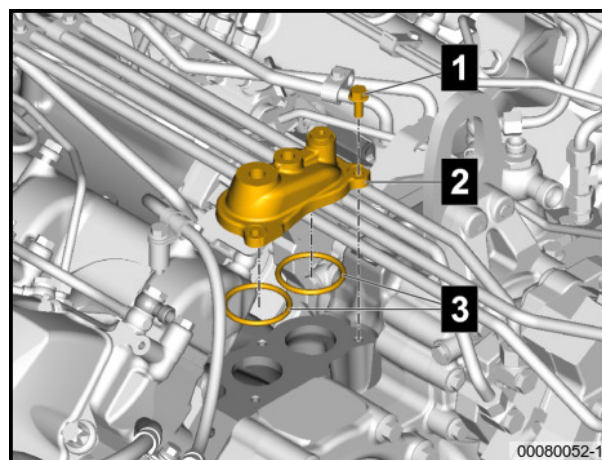

## Installing the coolant manifold on the engine block

### Mounting the coolant manifold

- ▶ Clean the sealing surfaces
- ▶ Apply a thin layer of radiator antifreeze on the new O-rings **3**
- ▶ Insert the new O-rings **3** in the coolant manifold **2**
- ▶ Position the coolant manifold **2**
- ▶ Screw in and tighten the mounting bolts **1**

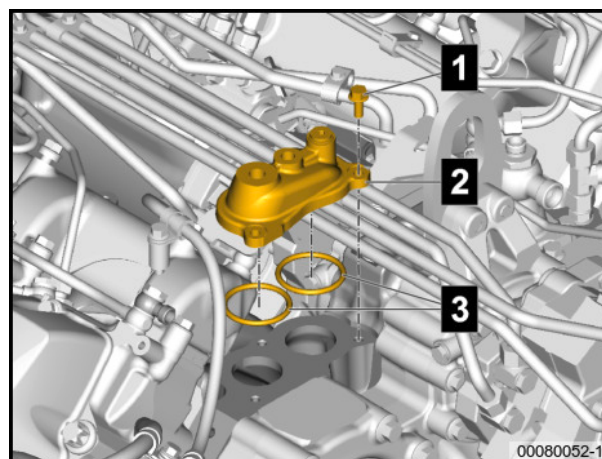

## Installing coolant lines

### Attaching the coolant line

#### Tip for users

Hollow screws are restricted.

- ▶ Attach the coolant line **3** with new seals
- ▶ Screw in and tighten hollow screw connector **5** and hollow screws **4**

Hollow screw, coolant M14x1.5..... 42 Nm  
line on cylinder head.....

- ▶ Position the ring union **1** with new sealing rings
- ▶ Screw in and tighten the hollow bolt **2**

### Attaching the coolant line

- ▶ Screw on the TVE connector **1**
- ▶ Position the coolant line **3**
- ▶ Screw on and tighten retaining nuts **4** and **6**
- ▶ Position the bushing **5**, screw in and tighten the mounting bolt **2**
- ▶ Tighten the TVE connector **1**

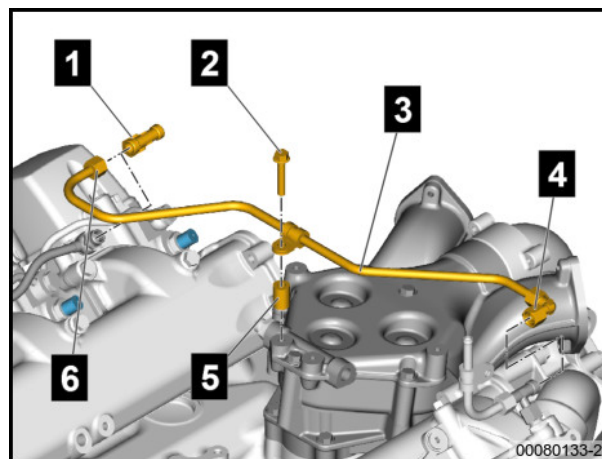
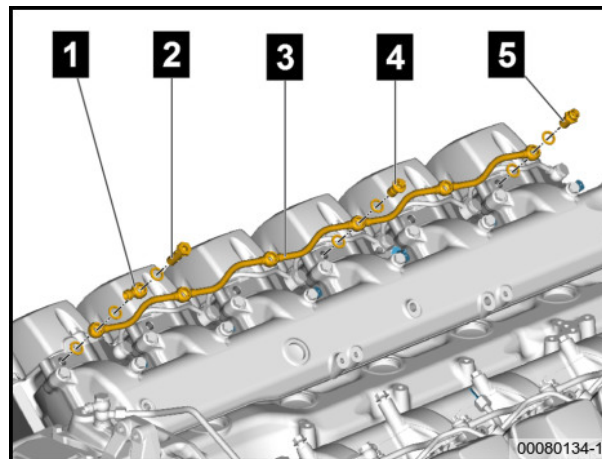

### Attaching the coolant line

- ▶ Position the coolant line **2**
- ▶ Screw on and tighten retaining nuts **1** and **3**

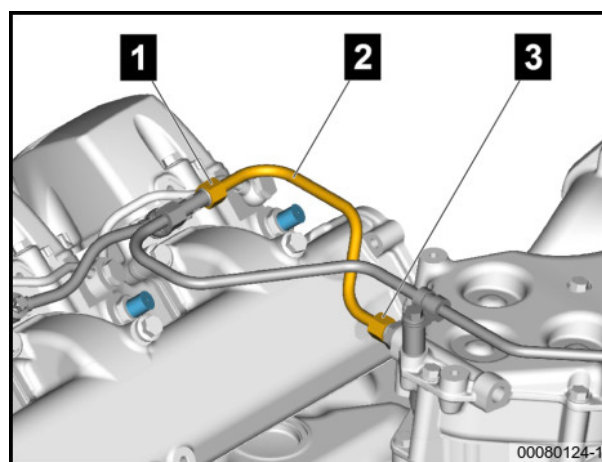

### Attaching the coolant line

- ▶ Position the coolant line **3**
- ▶ Screw on and tighten retaining nuts **1** and **2**

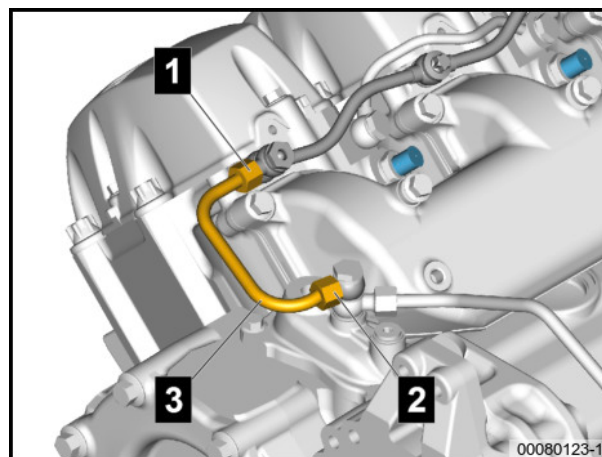

#### 4.1.1.7 Removing/installing the coolant line on the cylinder head (right)

Observe the safety instructions. Follow the instructions to the letter and proceed cautiously to prevent accidents, personal injury and material damage. Before commencing work, ensure that the latest documentation is used.

## 4.1 Cooling system (water cooling)

**Attaching the coolant line**

- ▶ Place the coolant line **2** on the thermostat housing
- ▶ Screw on and tighten the retaining nut on the WVE connector **1**

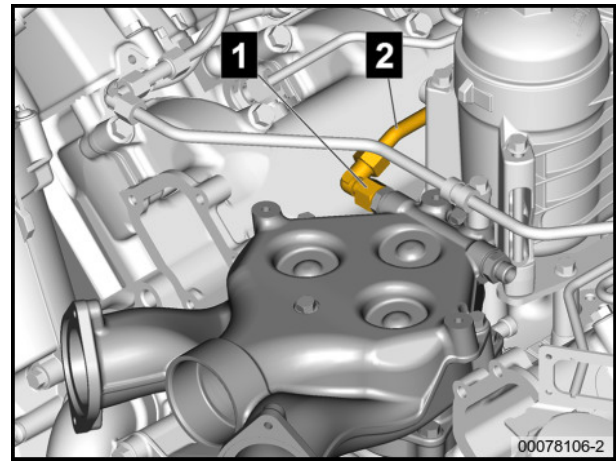
**Attaching the coolant line**

- ▶ Position the coolant line **2**
- ▶ Screw on and tighten the retaining nuts **1**

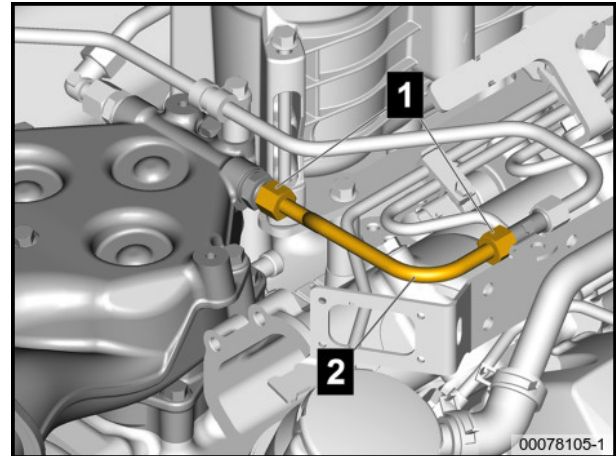
**Mounting the bracket**

- ▶ Position the bracket **2**
- ▶ Screw in and tighten the mounting bolts **1**

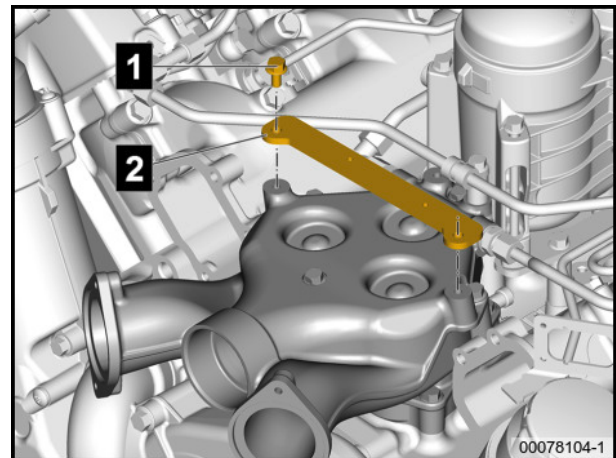
**4.1.2.3 Removing/installing the thermostat insert****Preparations**

- ▶ Removing/installing the thermostat housing , Page 85

## Installing the charge-air pipe

### Assembling the charge-air pipe

#### NOTICE

#### Risk of material damage to components due to leaking hose clips or clamp ring connections

For this reason:

- Adjust the seat of the hose clips or clamp rings by knocking gently with a rubber hammer.
- Tighten the hose clips or clamp rings again using a torque wrench.

- ▶ Insert new O-ring **3** in the groove
- ▶ Attach the cap **1** with clamp ring **2**
- ▶ Tighten the profile clamp **2**

Clamp ring..... M8x70..... 12 ±1 Nm

- ▶ Insert new O-ring **6** in the groove
- ▶ Attach the charge-air manifold **5** with clamp ring **4** as marked
- ▶ Tighten the profile clamp **4**

Clamp ring..... M8x70..... 12 ±1 Nm

### Attaching the charge-air pipe

- ▶ Clean the sealing surfaces
- ▶ Position the charge-air pipe **1** with new seals **3**
- ▶ Screw the mounting bolts **2** and **4** in as marked and tighten

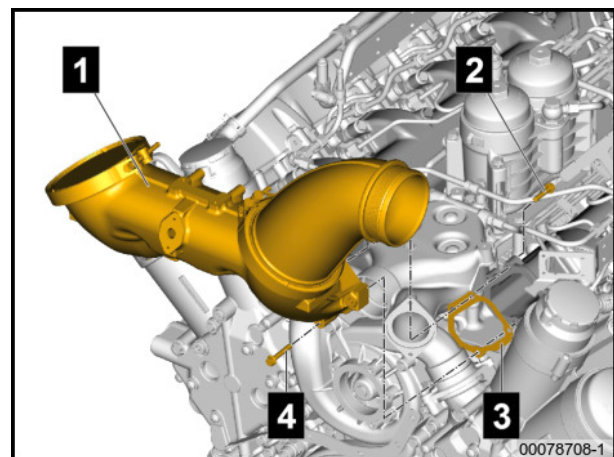
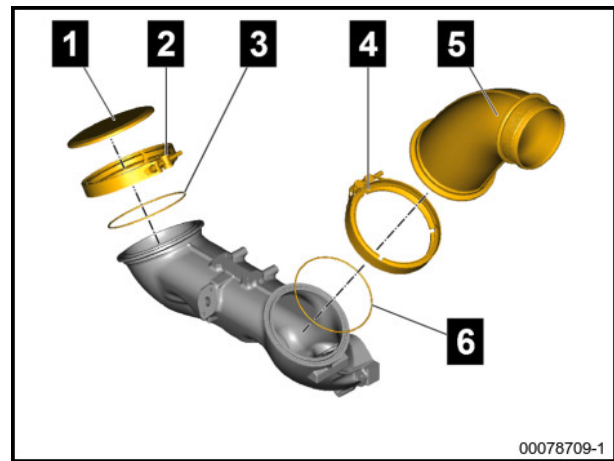

### Attaching the fuel lines

- ▶ Position the fuel lines
- ▶ Screw in and tighten the mounting bolts **3** and **4**
- ▶ Screw the mounting bolts **1** and **2** in with washers and then tighten

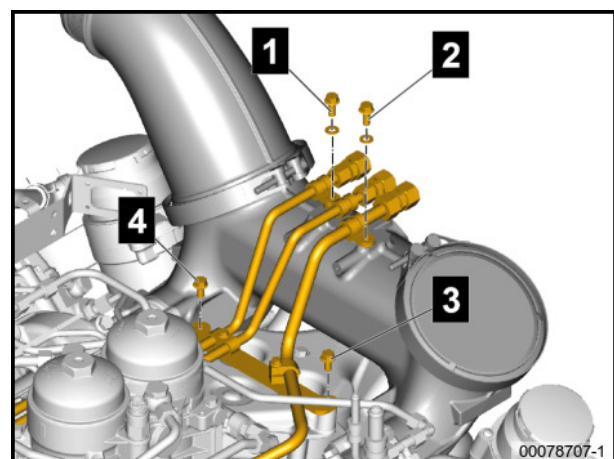

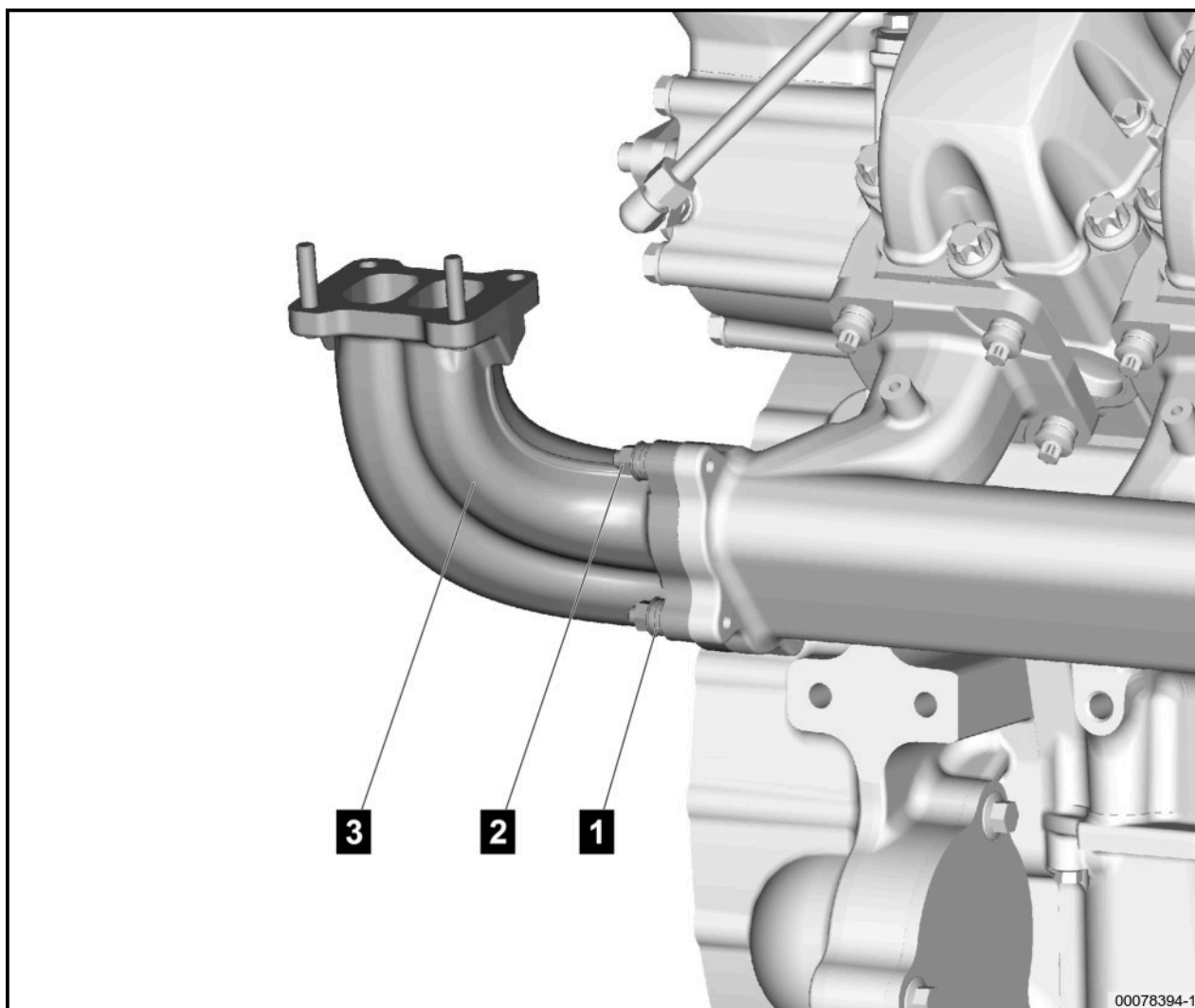

key

- 1** Spacer bush
- 2** Mounting nut
- 3** Exhaust pipe connector

#### Technical data

#### Tightening torques

Mounting nut..... M10-HWF.....	1. Torque.....	25 +5 Nm
Mounting nut..... M10-HWF.....	Final tightening.....	60 +10 °

#### Important information

### **NOTICE**

#### **Risk of material damage from incorrectly tightened bolted connections**

Components may be damaged.

For this reason:

- Only use an impact screwdriver to tighten to max. 50% of the prescribed torque.
- Final tightening must always be performed manually using a torque wrench.

5

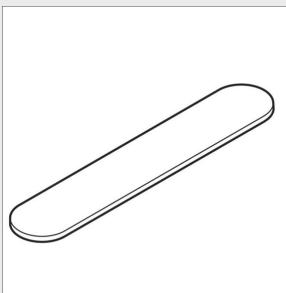
**Feeler gage blade 0.8**

80.99607-0179

Quantity 1

Feeler gage blade 0.8

- Checking and adjusting the valve clearance in conjunction

with:

- Holding device [3]
- Valve wrench size 14 [6]

6

**Valve adjustment spanner size 14**

80.99603-6031

Quantity 1

size 14 Adjust the valve clearance in conjunction with 08.06460-0003

**Valve adjustment wrench insert**

80.99603-0337

Quantity 1

7

**Handle**

08.06460-0003

Quantity 1

Detachable handle 9 x 12 - 150 mm Adjust the valve clearance

**Checking and adjusting the valve clearance****Removing cylinder head cover from cylinder 1**

- ▶ Unscrew the mounting bolts **1**
- ▶ Remove the cylinder head cover **2**

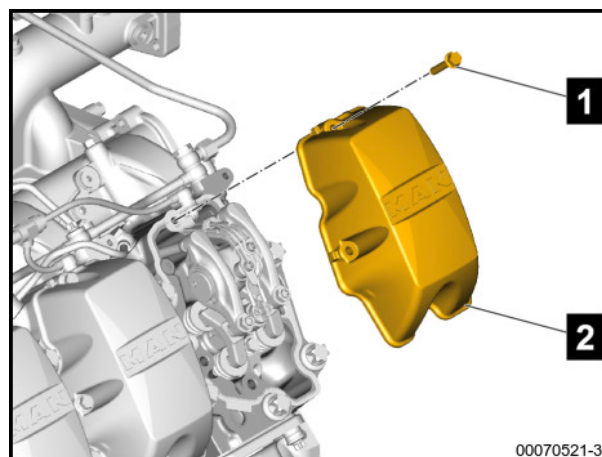

00070521-3

## 4.3.2 Rocker arm components

### 4.3.2.1 Checking the rocker arm

#### Preparations

- ▶ Removing/installing the cylinder head cover, Page 155

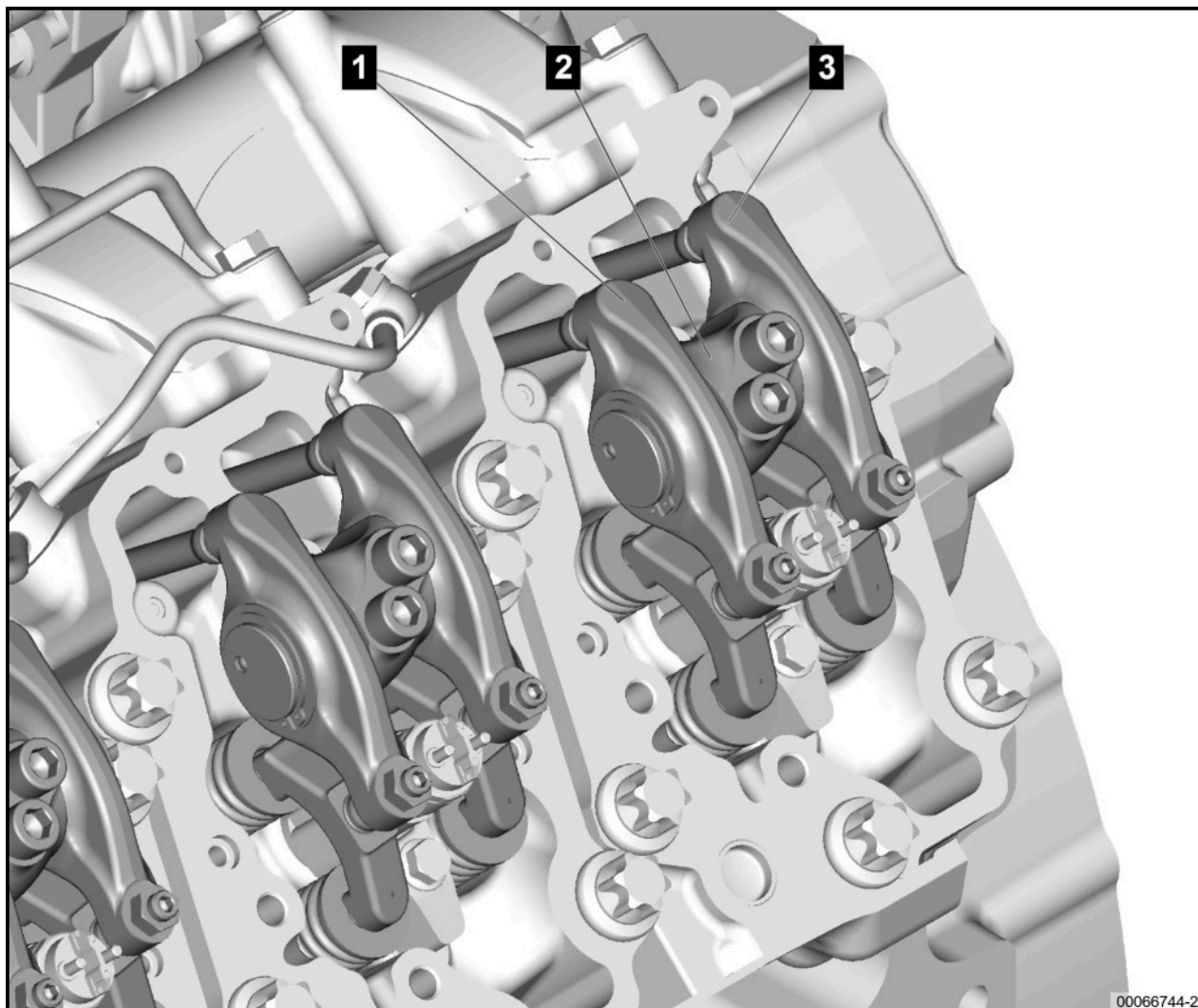

key

- 1** Exhaust valve
- 2** Rocker arm bracket
- 3** Intake valve

#### Technical data

##### Test values and settings

Rocker arm radial play.....	0.030 - 0.066 mm
Rocker arm bearing inner diameter.....	Diameter 34.005 - 34.025 mm

#### Important information

### NOTICE

#### Risk of material damage from incorrectly tightened bolted connections

Components will be damaged.

For this reason:

- Only use an impact screwdriver to tighten to max. 50% of the prescribed torque.
- Final tightening must always be performed manually using a torque wrench.

### Removing the camshaft

- ▶ Push out the camshaft **1** in the direction of the flywheel housing using the guide pin [1]
- ▶ Unscrew the guide pin [1]

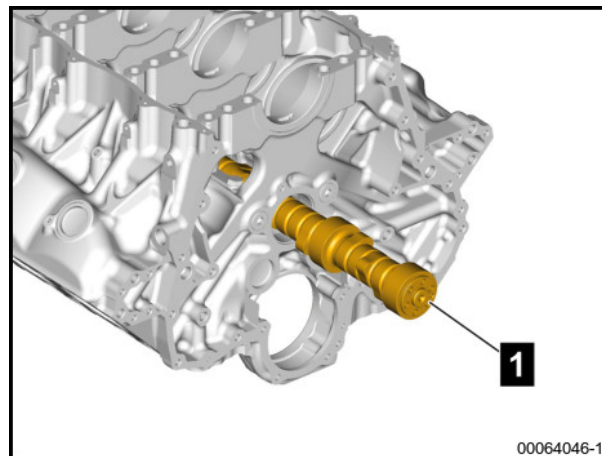

### Removing the oil nozzles

- ▶ Unscrew the mounting bolt **1**
- ▶ Pull the oil nozzle **2** out of the crankcase

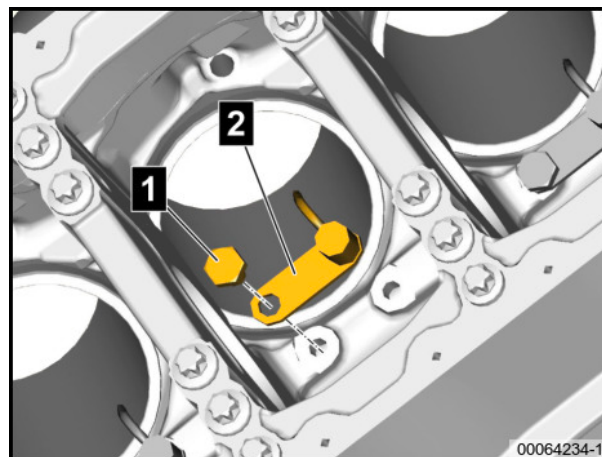

### Unscrewing the anti-turning device

- ▶ Remove anti-turning devices **1** and **2**

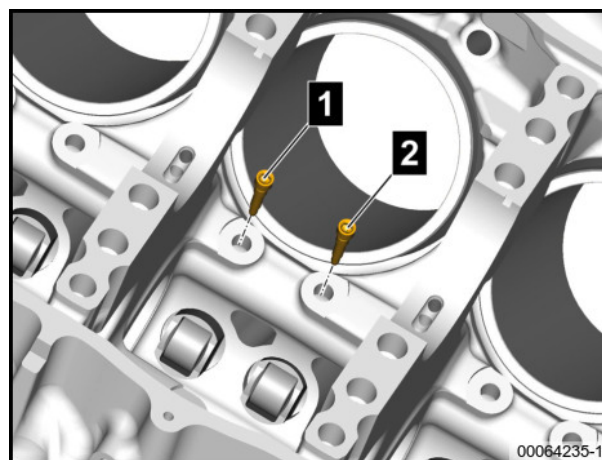

### Removing the roller plunger

- ▶ Pull the roller plunger **1** out of the crankcase **2**

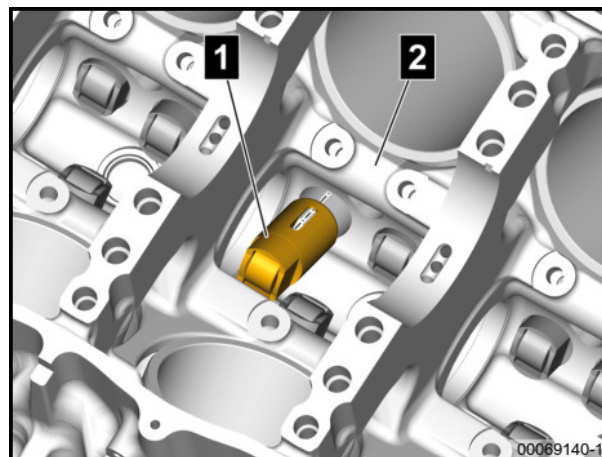

3

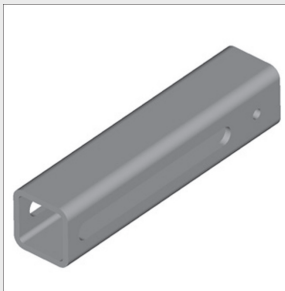
**Support**

80.99606-0551

Quantity 1

Loosening and tightening the cylinder head bolts

4

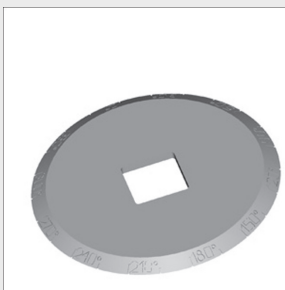
**Angle gage**

80.99607-0172

Quantity 1

Loosening and tightening the cylinder head bolts

5

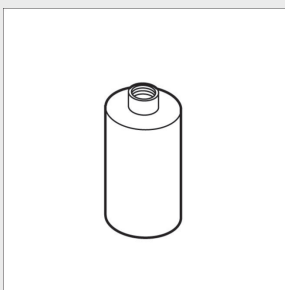
**Column**

80.99606-0641

Quantity 1

Support

- Loosening and tightening the cylinder head bolts in conjunction with:

- Socket wrench insert size 22 [1]
- Power amplifier wrench  $i = 1 : 3,3$  [2]
- Support [3]
- Angle gage [4]
- Stud bolt [6]
- Connecting pin [7]
- Rubber ring 42 mm [8]
- Guide adapter [9]
- Socket wrench insert [10]

6

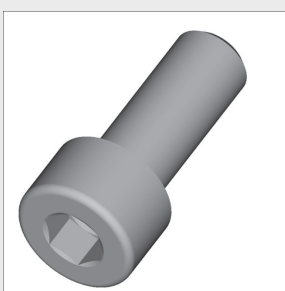
**Stud bolt**

06.02191-0407

Quantity 1

M8 x 20 - 10.9 - MAN 183-PHR Loosening and tightening the cylinder head bolts

7

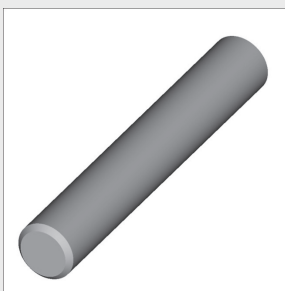
**Connecting pin**

06.22729-0006

Quantity 1

5.5 x 35 for 3/4" inserts, loosening and tightening the cylinder head bolts

## 4.5.1 Oil filter

## 4.5.1.1 Removing/installing the oil filter insert

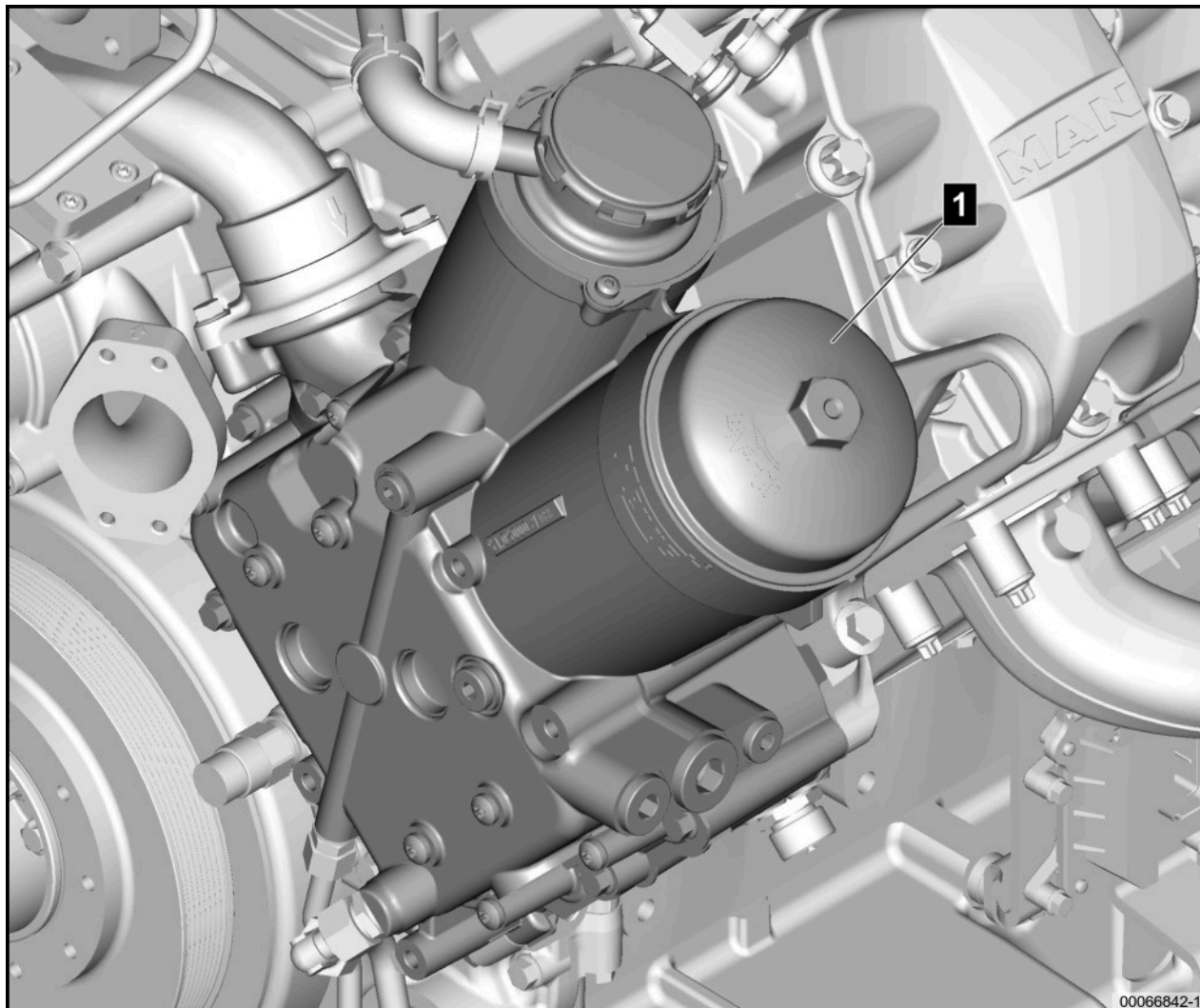

key

**1** Oil filter cover

**Technical data****Tightening torques**

Oil filter cover..... 40 +10 Nm

**Service products**

Engine oil ..... For more information see the MAN service product database

**Important information****NOTICE****Risk of material damage from incorrectly tightened bolted connections**

Components will be damaged.

For this reason:

- Only use an impact screwdriver to tighten to max. 50% of the prescribed torque.
- Final tightening must always be performed manually using a torque wrench.

**ENVIRONMENTAL WARNING**

Use a suitable container to collect any discharging engine oil.

**Literature reference**

For information on engine oil see the MAN service product database.

Observe the safety instructions. Follow the instructions to the letter and proceed cautiously to prevent accidents, personal injury and material damage. Before commencing work, ensure that the latest documentation is used.

### Tightening sequence for right oil module

- ▶ Tighten the mounting bolt **4**
- ▶ Loosen mounting bolts **4** 60°
- ▶ Tighten the mounting bolts **2**, **1**, **5** and **3**
- ▶ Tighten the mounting bolts **4**

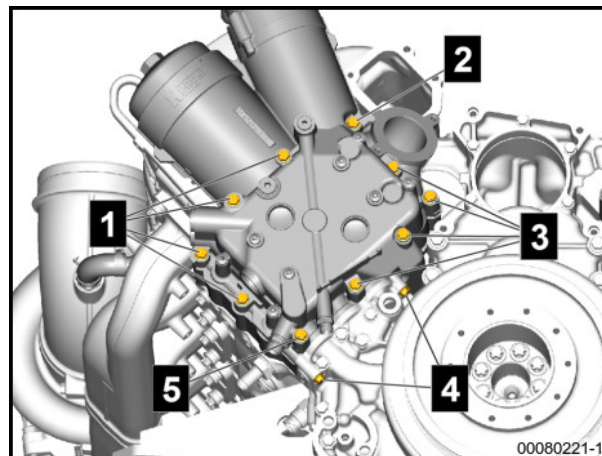

### Attaching right oil return line

- ▶ Position the oil return lines **2** and **5**
- ▶ Screw on the oil return line retaining nuts **2** and **5**
- ▶ Screw the retaining nut on the WVE connector **1**
- ▶ Tighten the oil return line retaining nuts **1**, **3** and the WVE connector **2**
- ▶ Install the fasteners **3** and **4** at the installation position

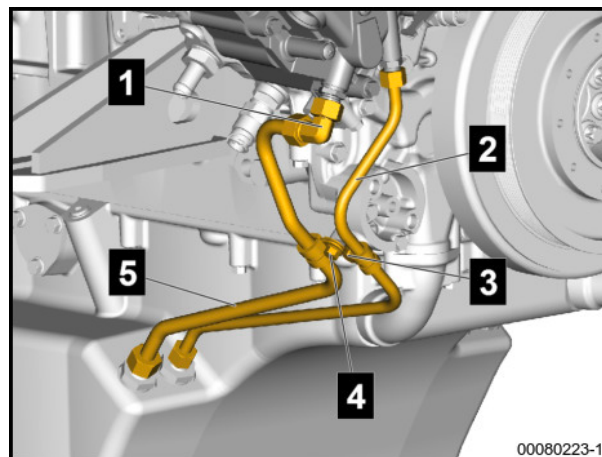

### Attaching the molded hose

- ▶ Position the molded hose **2** with the spring band clamps **1**
- ▶ Mount the spring band clamps **1** using the hose clamp pliers for spring band clamps [1]

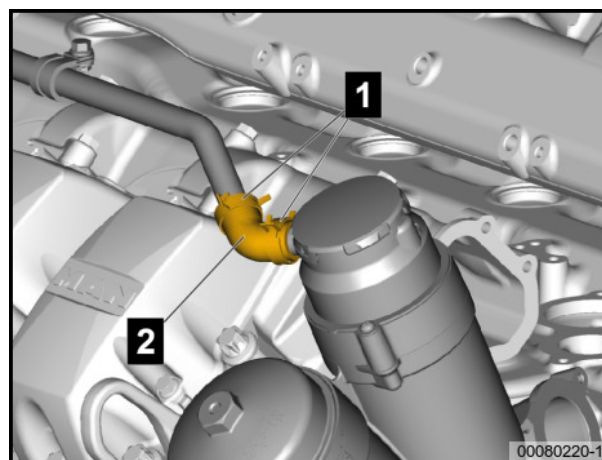

#### 4.5.1.4 Dismantling/assembling the oil module

##### Preparations

- ▶ Removing/installing the oil module (left), Page 161
- ▶ Removing/installing the oil module (right), Page 165

### Removing the manifold for the oil suction line

#### Removing the manifold for left oil suction line

- ▶ Unscrew the mounting bolts **3**
- ▶ Remove manifold **2** with O-ring **1**
- ▶ Pull the coupling pipe **4** out
- ▶ Clean the sealing surfaces

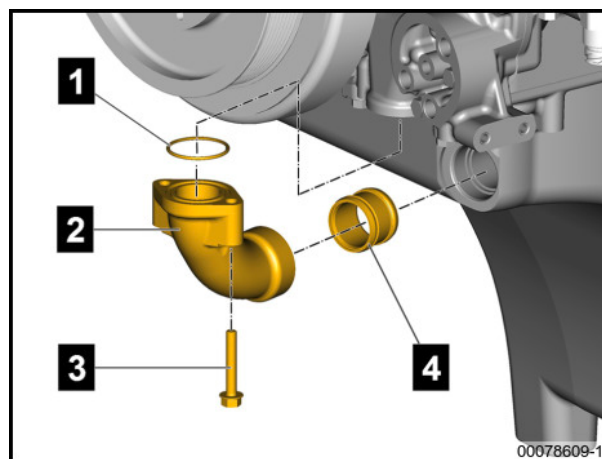

#### Removing the manifold for right oil suction line

- ▶ Unscrew the mounting bolts **3**
- ▶ Remove manifold **2** with O-ring **1**
- ▶ Pull the coupling pipe **4** out
- ▶ Clean the sealing surfaces

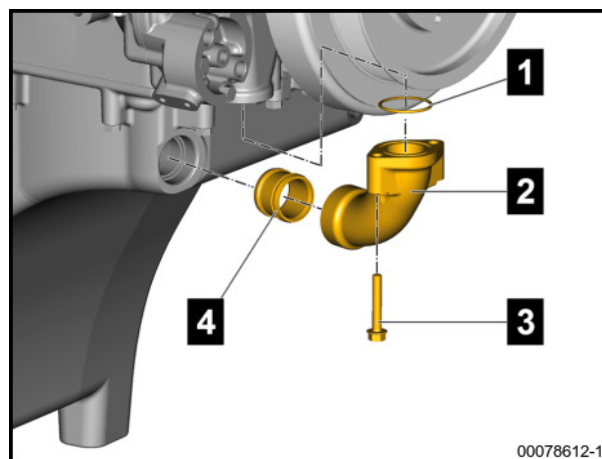

### Installing the manifold for the oil suction line

#### Attaching the manifold for the right oil suction line

- ▶ Clean the sealing surfaces
- ▶ Apply a thin layer of clean engine oil to the new O-ring **1** and new coupling pipe **4**
- ▶ Insert the new coupling pipe **4**
- ▶ Attach the manifold **2** with new O-ring **1**
- ▶ Screw in and tighten the mounting bolts **3**

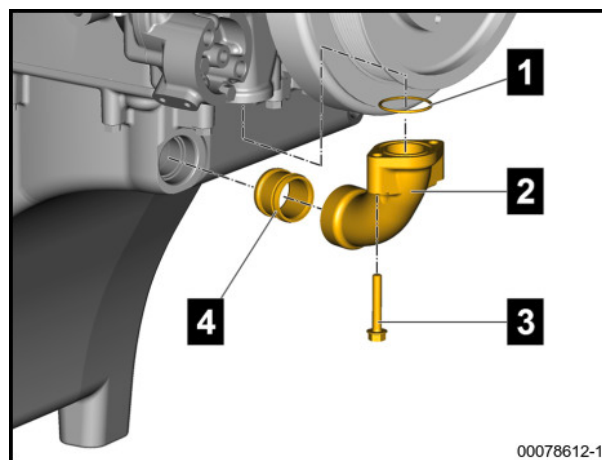

#### Attaching the manifold for left oil suction line

- ▶ Clean the sealing surfaces
- ▶ Apply a thin layer of clean engine oil to the new O-ring **1** and new coupling pipe **4**
- ▶ Insert the new coupling pipe **4**
- ▶ Attach the manifold **2** with new O-ring **1**
- ▶ Screw in and tighten the mounting bolts **3**

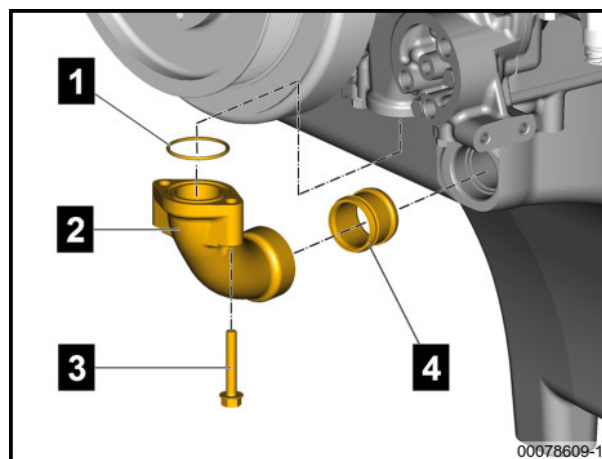

### 4.5.3.2 Removing/installing the oil pump suction line/intake pipe

Observe the safety instructions. Follow the instructions to the letter and proceed cautiously to prevent accidents, personal injury and material damage. Before commencing work, ensure that the latest documentation is used.

## Important information

**NOTICE****Risk of material damage from incorrectly tightened bolted connections**

Components will be damaged.

For this reason:

- Only use an impact screwdriver to tighten to max. 50% of the prescribed torque.
- Final tightening must always be performed manually using a torque wrench.

**Dismantling the oil sump****Remove the blind flanges and plugs**

- ▶ Unscrew and remove the plugs **1**, **2**, **4**, **6** and **8** with the sealing rings
- ▶ Unscrew and remove the drain valve **9** with the sealing ring
- ▶ Unscrew the mounting bolts in the blind flange **3**
- ▶ Remove the blind flange **3** with the seal
- ▶ Unscrew the mounting bolts in the blind flange **5**
- ▶ Remove the blind flange **5** with the seal
- ▶ Unscrew the mounting bolts in the blind flange **7**
- ▶ Remove the blind flange **7** with the seal
- ▶ Clean the sealing surfaces

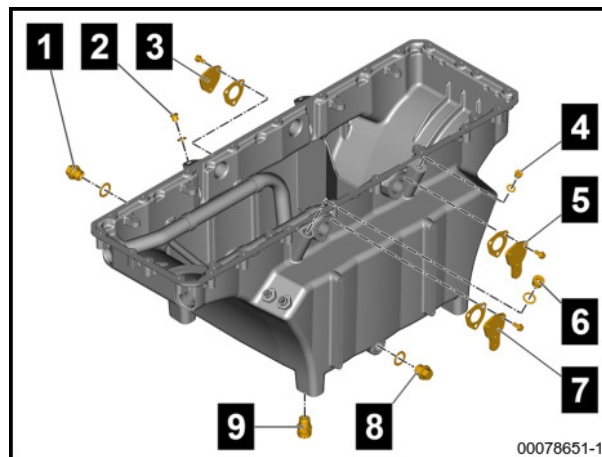
**Removing the oil return line****Tip for users**

Removal of the left oil return line is the same as that of the right oil return line.

- ▶ Loosen the mounting bolts **3**
- ▶ Unscrew the oil return lines **1** and **2**
- ▶ Unscrew the oil return lines **1** and **2** and remove them along with the sealing rings

Repeat this procedure for the return lines on the right

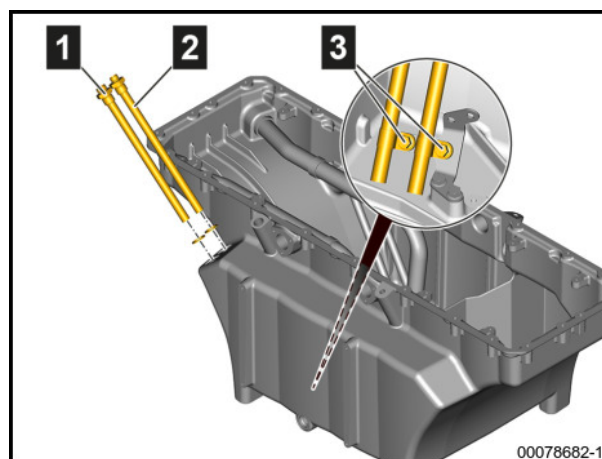
**Removing the oil return line bracket****Tip for users**

Removal of the left oil return line bracket is the same as that of the right oil return line bracket.

- ▶ Unscrew the mounting bolt **3** and remove along with the washer and retaining clamp **4**
- ▶ Unscrew the mounting bolt **2**
- ▶ Remove the bracket **1**

Repeat this procedure for the return lines on the right

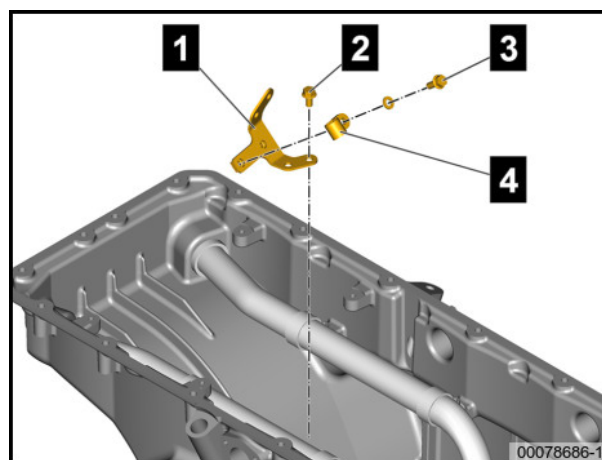

## Dismantling the vibration damper

### NOTICE

**Risk of material damage if the vibration damper is set down incorrectly**

For this reason:

- Do not lay the vibration damper down on the discs

- ▶ Unscrew the mounting bolts **3**
- ▶ Remove the hub **1** from the vibration damper **2**

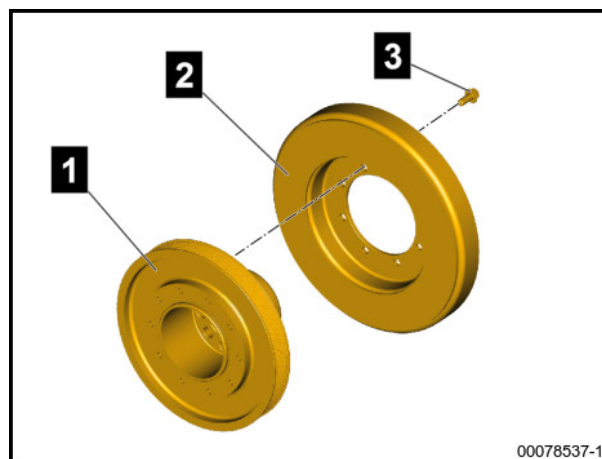

## Assembling the vibration damper

- ▶ Insert the hub **1** into the vibration damper **2**
- ▶ Screw in and tighten new mounting bolts **3**

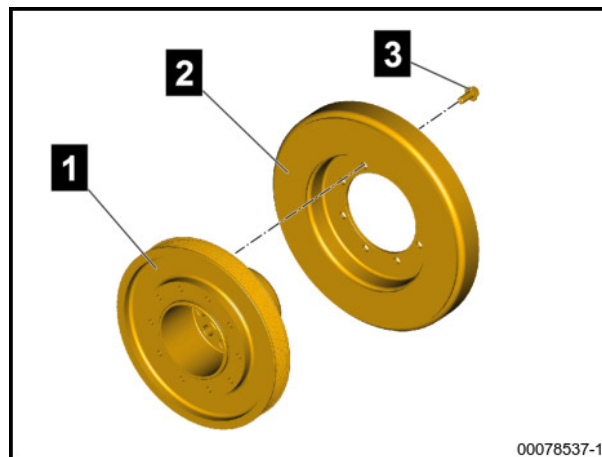

## Installing the vibration damper

### Fitting the vibration damper

- ▶ Screw the centering pins [1] **3** and **4** in
- ▶ Put on the vibration damper **2**
- ▶ Screw the mounting bolts **1** in and tighten by hand

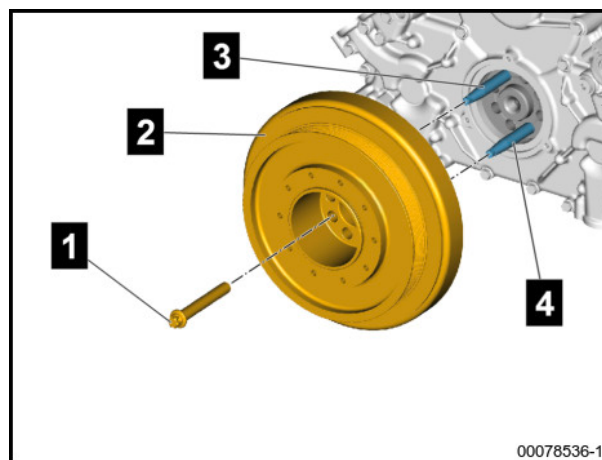

### Unscrewing the centering pins

- ▶ Unscrew the centering pins [1] **1** and **2**

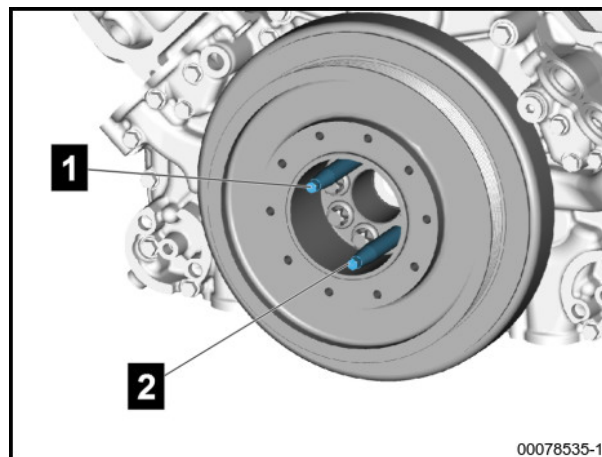

## Removing the flywheel ring gear

### Detaching the flywheel ring gear

#### ⚠ CAUTION

#### Risk of injury from chippings

For this reason:

- Wear personal protective equipment

#### NOTICE

#### Risk of material damage due to spot-drilling of the flywheel

For this reason:

- Take care not to damage the flywheel when spot-drilling the flywheel ring gear
- Fit a new spot-drilled flywheel

- ▶ Spot-drill the starter ring gear **1** and force it open
- ▶ Remove the starter ring gear **1** from the flywheel **2**
- ▶ Clean the contact surfaces of the starter ring gear **1** and the flywheel **2** and check for damage

## Installing the starter ring gear

### Attaching the starter ring gear

- ▶ Heat the starter ring gear **1** to 200 - 230 °C
- ▶ Fit the starter ring gear **1** so that the chamfer on the teeth is facing away from the flywheel
- ▶ Fit the starter ring gear **1** so that the holes of the starter ring gear **1** and the flywheel **2** are in line
- ▶ Adjust the flywheel ring gear **1** if necessary

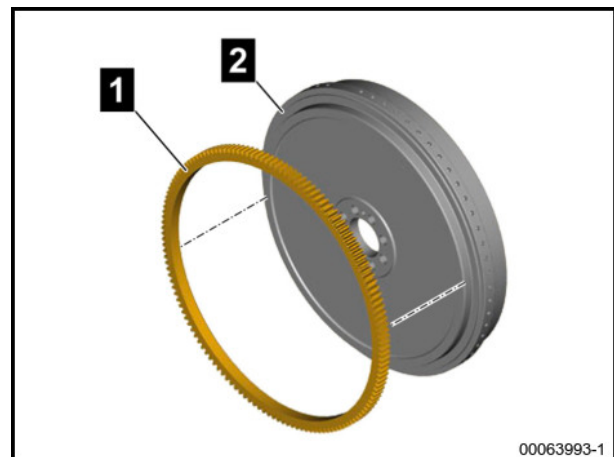
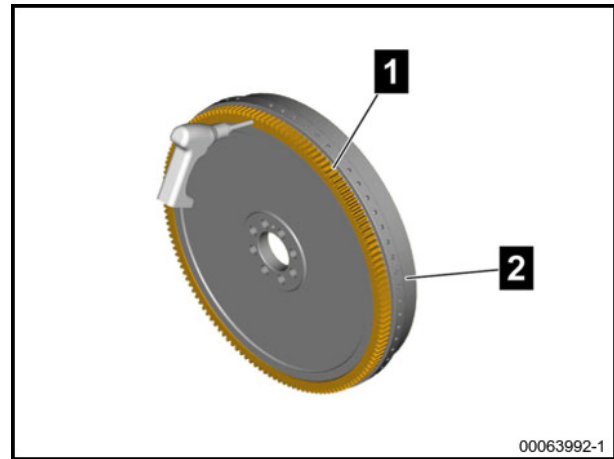

## Removing the oil pump gear

### Detaching the oil pump gear

- ▶ Screw in the centering pins [1] **2** and **3**
- ▶ Pull off the oil pump gear **1** over the centering pins [1] **2** and **3**
- ▶ Clean the contact surfaces of the oil pump gear **1** and crankshaft

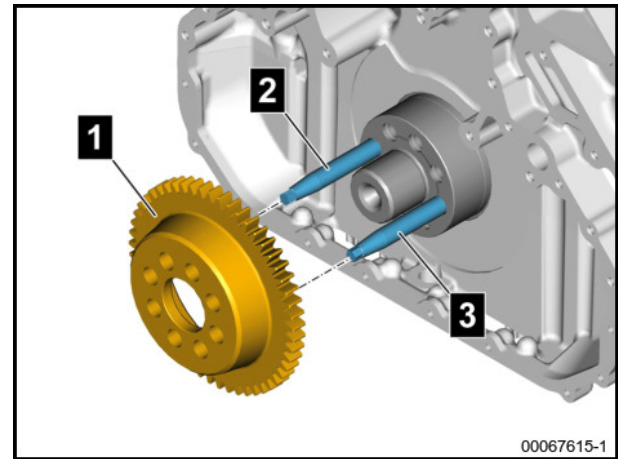

## Installing the oil pump gear

### Attaching the oil pump gear

- ▶ Clean the contact surfaces of the oil pump gear **1** and crankshaft
- ▶ Push the oil pump gear **1** over the centering pins [1] **2** and **3** until it stops
- ▶ Unscrew the centering pins [1] **2** and **3**

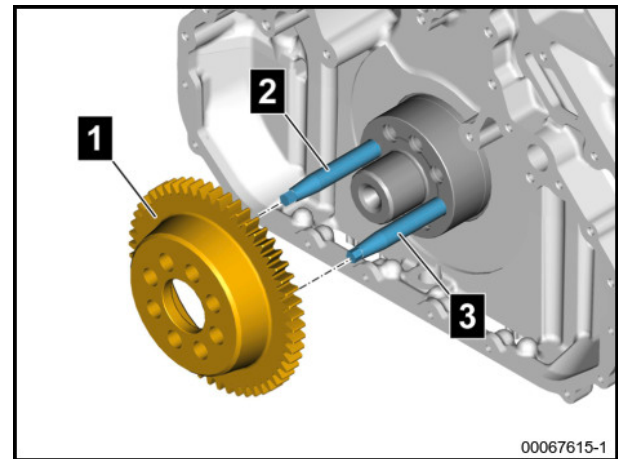

### 4.6.4.6 Removing/installing the crankshaft gear (rear)

### Positioning the power amplifier wrench

- ▶ Fit the special tool **1** onto the mounting bolts to be loosened **2**
- ▶ Insert the handle [17] **3** and ratchet [16] into the special tool **1**

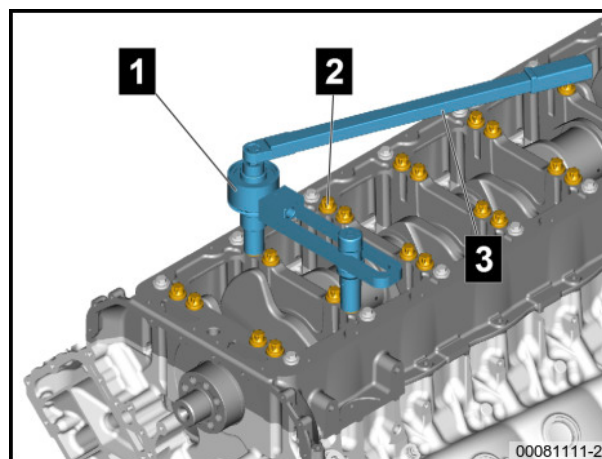

### Loosening the crankcase lower section internal mounting bolts

- ▶ Loosen mounting bolts **1** through **28** with the special tool
- ▶ Remove mounting bolts **1** through **28**
- ▶ Disassemble the special tool

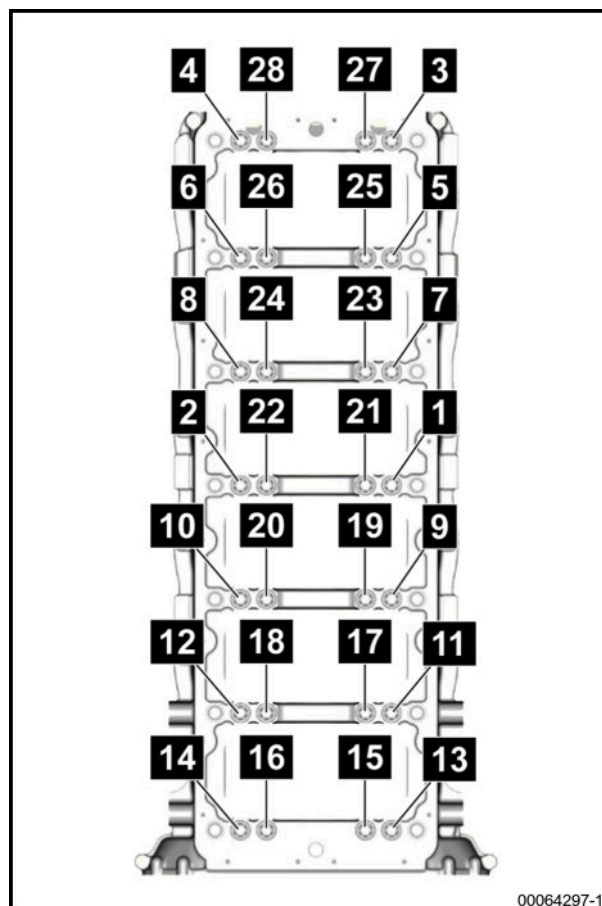

### Removing the crankcase lower section

#### ▲ CAUTION

#### Danger of injury due to heavy components

For this reason:

- Lift crankcase lower section with support

#### NOTICE

#### Risk of material damage due to main bearing shells falling out

For this reason:

- When taking off the crankcase lower section, be aware of falling main bearing shells

- ▶ Screw the jacking screws [7] **1** into the crankcase housing lower section at positions **1**
- ▶ Tighten jacking screw [7] hand-tight

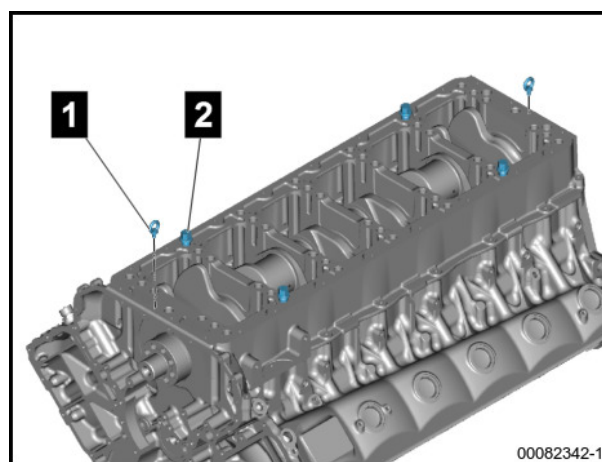

CLICK HERE TO **DOWNLOAD** THE COMPLETE MANUAL

- Thank you very much for reading the preview of the manual.
- You can download the complete manual from: [www.heydownloads.com](http://www.heydownloads.com) by clicking the link below



- Please note: If there is no response to CLICKING the link, please download this PDF first and then click on it.

CLICK HERE TO **DOWNLOAD** THE COMPLETE MANUAL

**NOTICE****Risk of material damage to components if bolts are reused**

For this reason:

- Do not reuse crankshaft bearing cap mounting bolts

**Tip for users**

The repair manual describes the repair method of an engine variant as an example.

Pictures and the corresponding descriptions do not always correspond to the engine being repaired as it was not possible to take into account all engine variants.

In cases such as these, plan and execute the instructions from the repair manual accordingly

**Special tools**

1

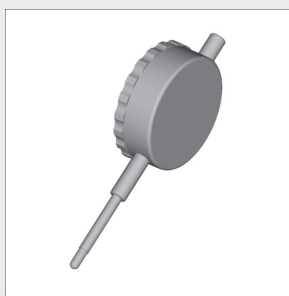
**Dial gage**

Quantity 1

Check the inner diameter of the crankshaft bearing

08.71000-3217

2

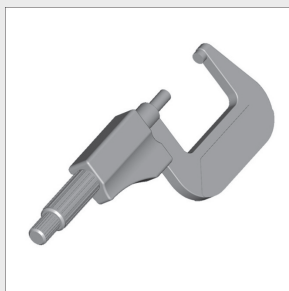
**Micrometer**

Quantity 1

08.71200-9005

**Checking the crankshaft****Check the crankshaft bearing spread****Tip for users**

The difference between dimensions **A** and **B** gives the bearing spread.

- ▶ Clean the crankshaft bearing shells **2** and place them together on a flat surface as marked
- ▶ Check dimension **A** using a micrometer **1**
- ▶ Check dimension **B** using a micrometer **1**

The permissible max. spread of the crankshaft bearing is max.

2 mm.

The crankshaft bearing shells must be replaced if the spread is outside the tolerance.

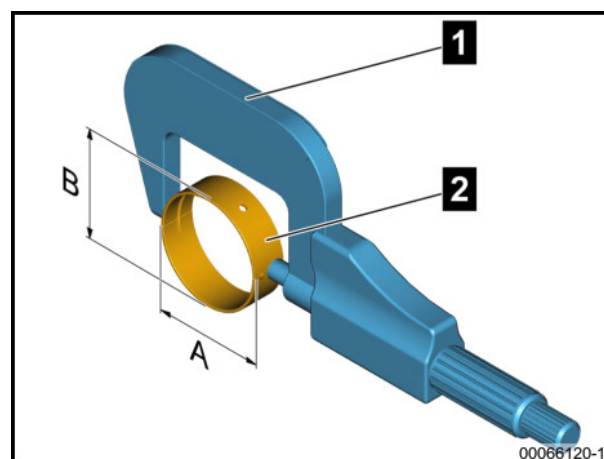

**Technical data****Test values and settings****Piston pin/piston pin hole**.....

Piston pin diameter..... 54.994 - 55.000 mm

Piston pin hole..... 55.063 - 55.093 mm

**Important information****NOTICE****Risk of material damage from incorrectly tightened bolted connections**

Components will be damaged.

For this reason:

- Only use an impact screwdriver to tighten to max. 50% of the prescribed torque.
- Final tightening must always be performed manually using a torque wrench.

**Special tools**

1

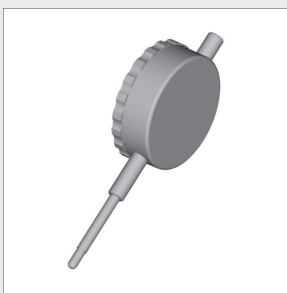
**Dial gage**

Quantity 1

Adjusting the pre-load of the EGR adjusting cylinder within the intake / exhaust system

08.71000-3217

**Dismantling the piston****Dismantling the piston**

- ▶ Mark the relative positions of the piston **2**, piston pin **4** and connecting rod **5**
- ▶ Detach inside locking ring **1** and **3**
- ▶ Press the piston pin **4** out of the piston **2**
- ▶ Remove the piston **2**

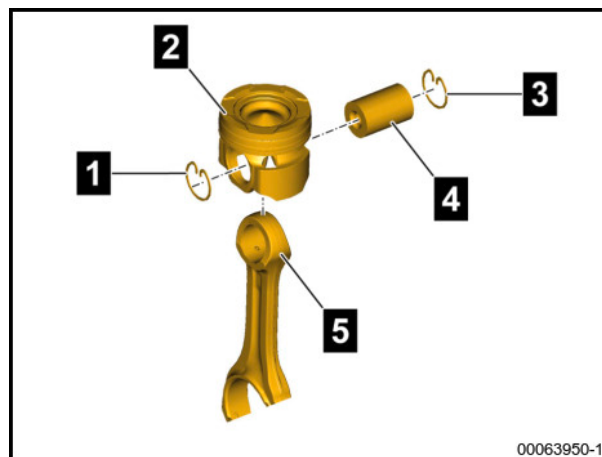

00063950-1

**Measuring the piston pin****Measuring the piston pin**

- ▶ Measure the piston pin **1** using a micrometer **2**

If the dimensions of the piston pin **1** lie outside the tolerance limits of 54.994 - 55.000 mm, the piston must be replaced with the piston pin **1**.

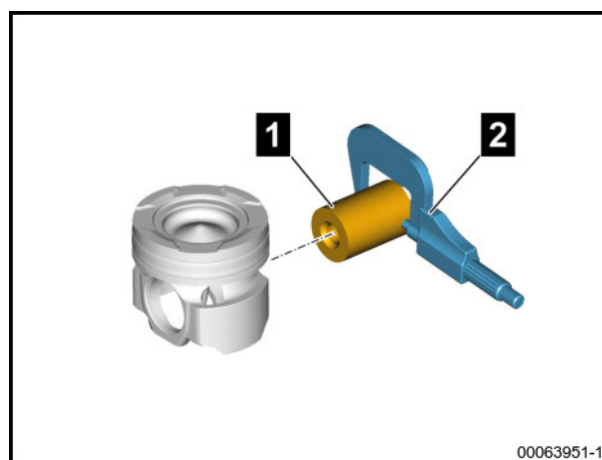

00063951-1

## 4.7.2 Flywheel housing, engine flange

### 4.7.2.1 Removing/installing the flywheel housing

#### Preparations

- ▶ Removing/installing the PTO cover, Page 425
- ▶ Removing/installing the air compressor (single cylinder), Page 407
- ▶ Removing/installing the starter/starter motor, Page 56
- ▶ Removing/installing the flywheel, Page 201
- ▶ Removing/installing the fuel line, Page 320
- ▶ Removing/installing the high pressure pump (rear), Page 379
- ▶ Removing/installing the high pressure pump (front), Page 376
- ▶ Removing/installing the high-pressure pump drive housing, Page 390
- ▶ Removing/installing the crankshaft gear (rear), Page 219
- ▶ Removing/installing the rear crankshaft radial shaft seal, Page 265

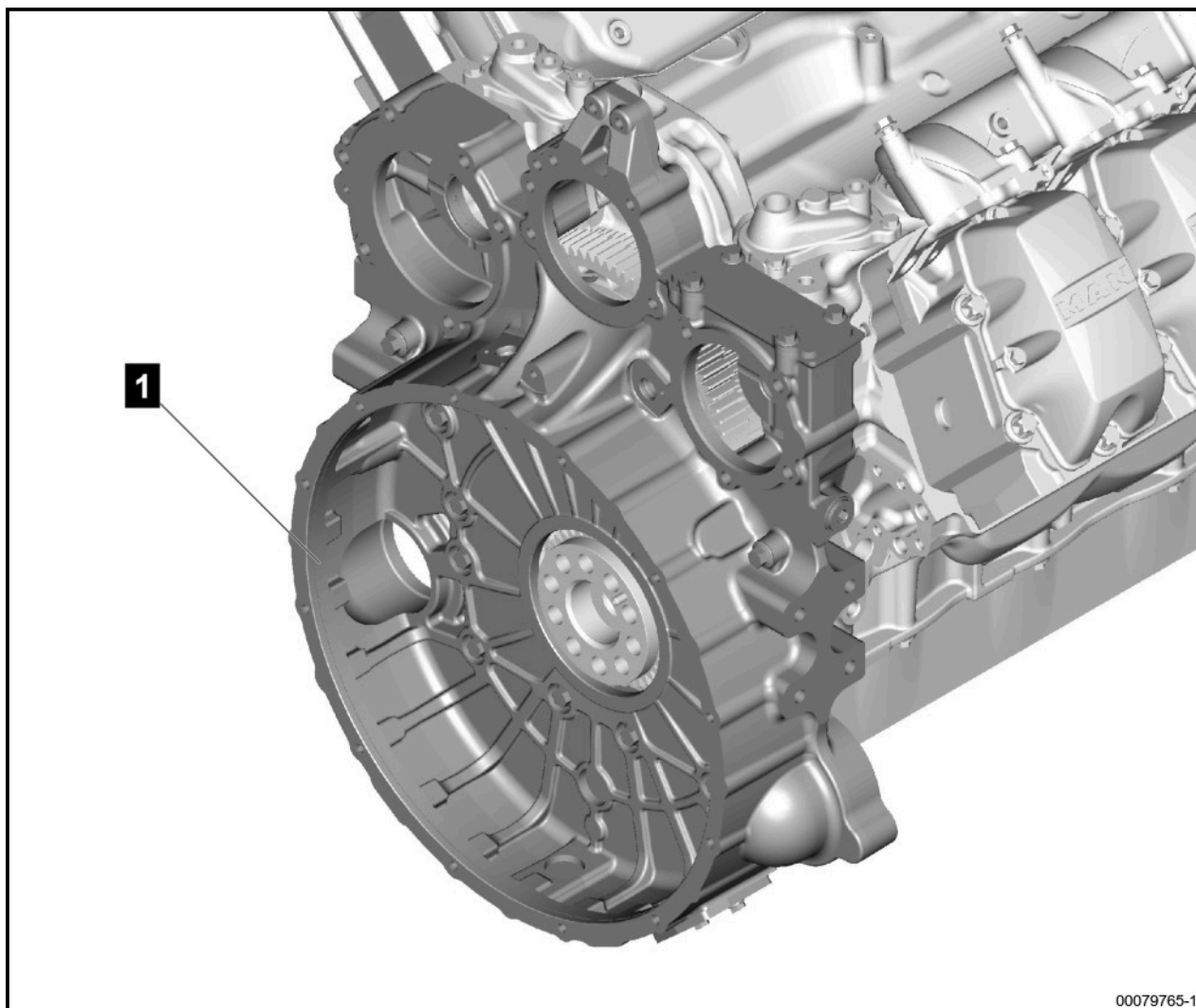

00079765-1

key

**1** Flywheel housing

#### Important information

### NOTICE

#### Risk of material damage from incorrectly tightened bolted connections

Components will be damaged.

For this reason:

- Only use an impact screwdriver to tighten to max. 50% of the prescribed torque.
- Final tightening must always be performed manually using a torque wrench.

### Checking the markings of the crankshaft gear and the camshaft gear

- ▶ Check the markings of the crankshaft gear **1** and the camshaft gear **2**

Markings **1** and **2** coincide.

If markings **1** and **2** do not coincide, remove the crankshaft gear and install it on the marking; if necessary, align the crankshaft with the alignment pin.

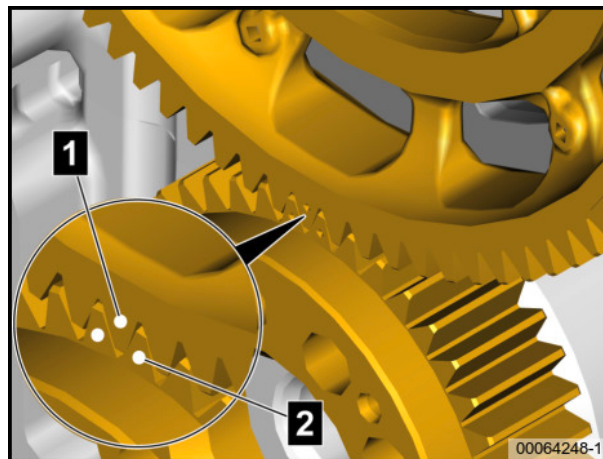

### Installation preparation for radial shaft seal

- ▶ Separate two opposite discs each from the transport sleeve
- ▶ Position the radial shaft seal **3** with the supplied transport sleeve on the guide plate [6] **2**
- ▶ Push the radial shaft seal **3** carefully onto the guide plate [6] **2**
- ▶ Push the guide plate [6] **2** over the centering pin [8] **1** and **4**
- ▶ Remove the transport sleeve

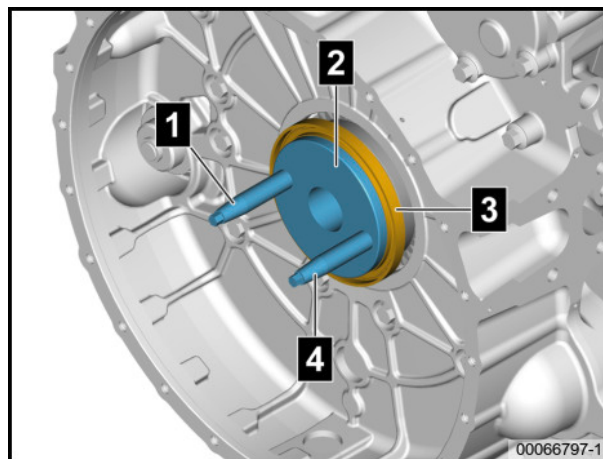

### Pressing in the radial shaft seal

- ▶ Assemble the press-in bush [7] with the detachable handle [4] **5** and washer [5] **3**
- ▶ Push the special tool over the centering pin [8] **1** and **4** onto the guide plate [6] **2**
- ▶ Using the special tool, press the radial shaft seal into the flywheel housing **6** until the press-in bush [7] is in contact with the guide plate [6] **2**
- ▶ Remove the special tool

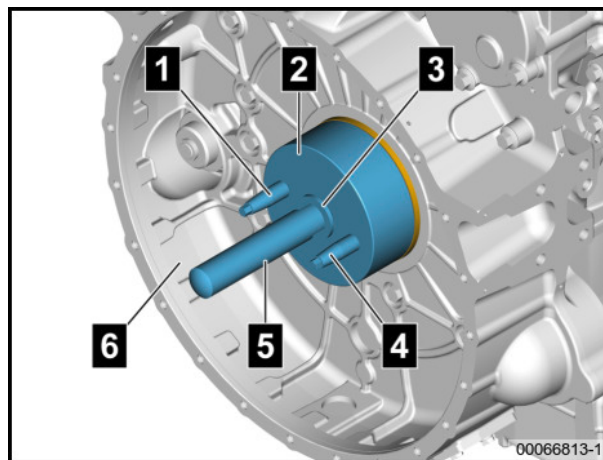

#### 4.7.3.2 Removing/installing the front crankshaft radial shaft seal

##### Preparations

- ▶ Removing/installing the vibration damper, Page 197

## Removing the oil nozzle

### Removing the oil nozzle

- ▶ Unscrew the mounting bolt **1**
- ▶ Pull the oil nozzle **2** out of the crankcase

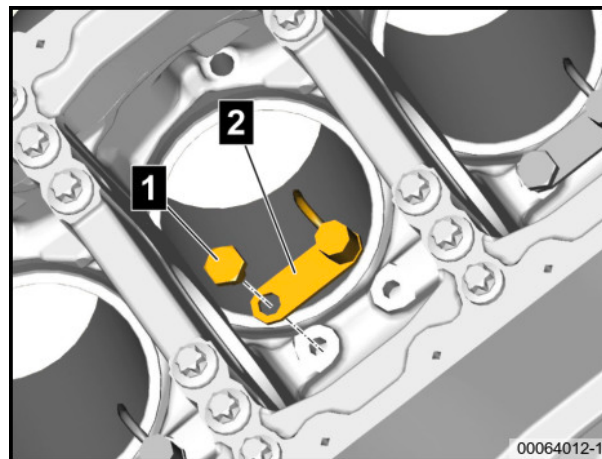

## Installing the oil nozzle

### Installing the oil nozzle

- ▶ Insert the oil nozzle **2** into the crankcase
- ▶ Screw in and tighten new mounting bolt **1**

Oil nozzle	M14x20-10.9.....	115 Nm
mounting bolt on crankcase.....		+10

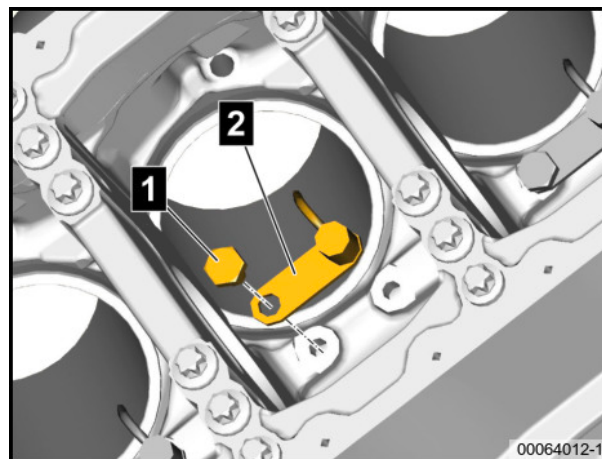

## Removing the intake fitting

### Removing the threaded union

- ▶ Unscrew and remove the threaded union **4** with the sealing ring **3**
- ▶ Unscrew the screw plug **2** and remove with the sealing ring **1**

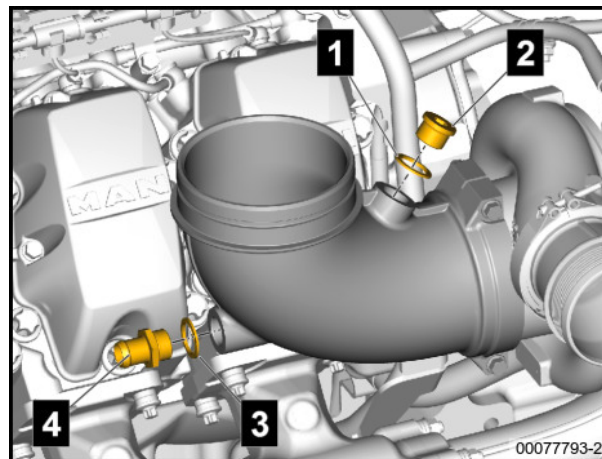

## Removing the intake fitting

- ▶ Mark the installation position of the intake fitting **1**
- ▶ Loosen the mounting bolts **3**
- ▶ Remove the threaded union **1** from the turbocharger
- ▶ Remove the O-ring **2** from the intake fitting **1**
- ▶ Clean the sealing surfaces

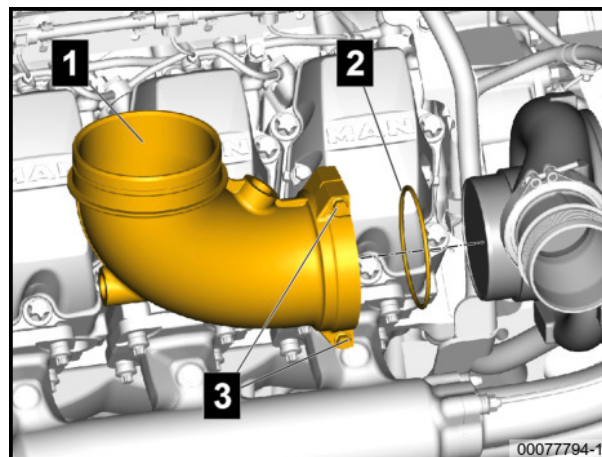

## Attaching the intake fitting

### Installing the intake fitting

- ▶ Clean the sealing surfaces
- ▶ Insert a new O-ring **2** into the intake fitting **1**
- ▶ Position the intake fitting **1** as marked on the turbocharger
- ▶ Tighten the mounting bolts **3**

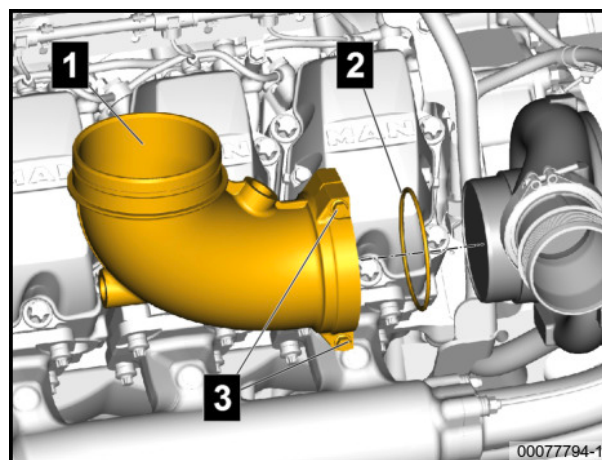

## Attaching the threaded union

- ▶ Screw the screw plug **2** in with a new sealing ring **1** and then tighten
- ▶ Screw the threaded union **4** in with a new sealing ring **3** and then tighten

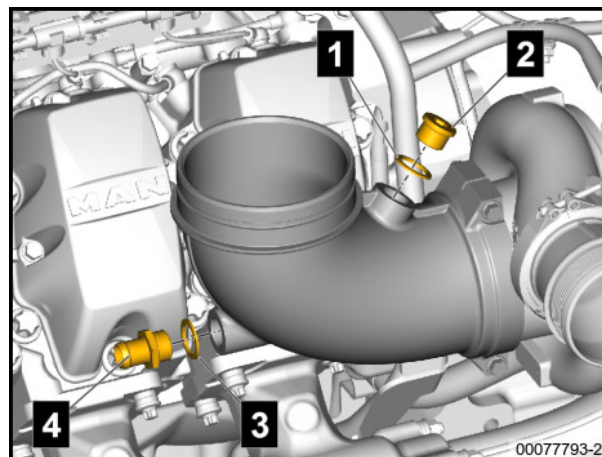

### 4.8.1.2 Intake fitting, right turbocharger

**Preparations**

- ▶ Removing/installing the crankcase ventilation (right), Page 281

- ▶ Intake fitting, right turbocharger, Page 289

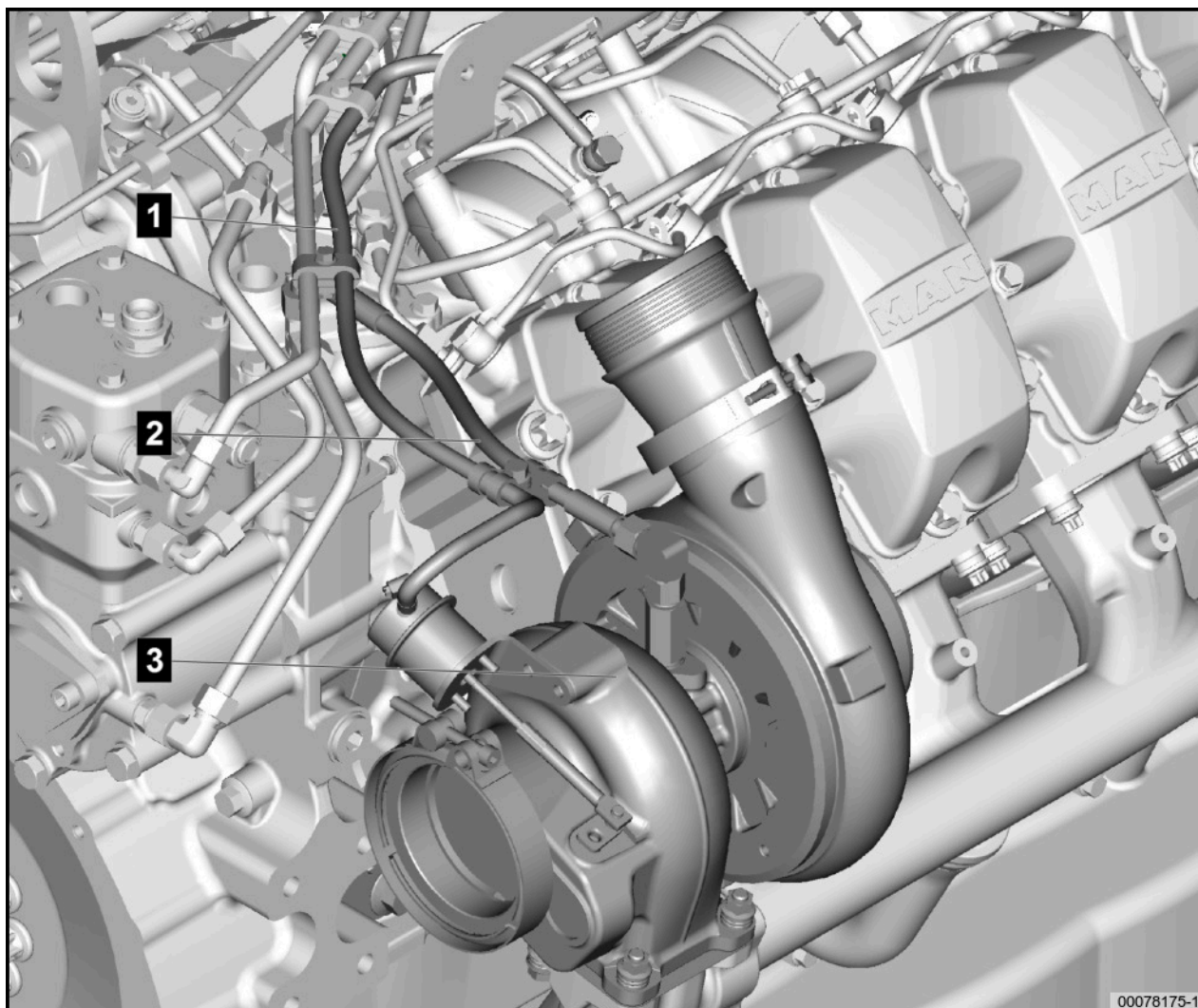

key

- 1** Hose
- 2** Hose
- 3** Right turbocharger

**Technical data****Tightening torques**

Mounting nut, turbocharger on exhaust pipe M10.....	1. Torque.....	25 +5 Nm
connector.....		
Mounting nut, turbocharger on exhaust pipe M10.....	Final tightening.....	60 +10°
connector.....		
Clamp ring.....M6 x 50.....		6 ±1 Nm

**Important information****NOTICE****Risk of material damage from incorrectly tightened bolted connections**

Components will be damaged.

For this reason:

- Only use an impact screwdriver to tighten to max. 50% of the prescribed torque.
- Final tightening must always be performed manually using a torque wrench.

## Removing the fuel filter insert

Allow the Fuel Service Center (KSC) to empty

### ENVIRONMENTAL WARNING

Collect any fuel that escapes in a suitable container.

- ▶ Undo the cover **1** using a size 36 socket [1] with approx 2 to 3 revolutions
- ▶ Place a suitable container under the plug **3**
- ▶ Remove the plugs **3**
- ▶ Open the drain valve **2** and allow the KSC to drain into the prepared container
- ▶ Close the drain valve **2**.
- ▶ Installed the plug **3**

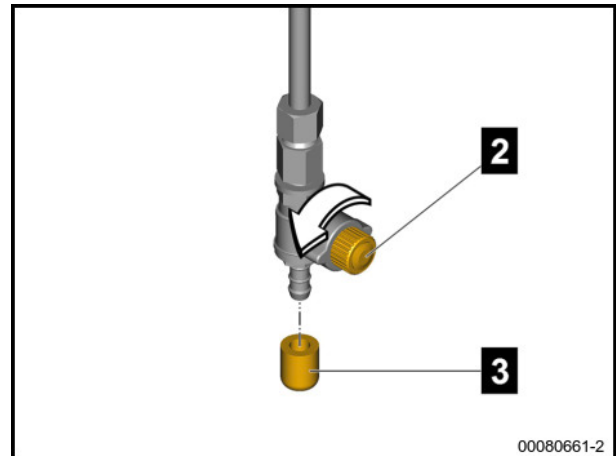
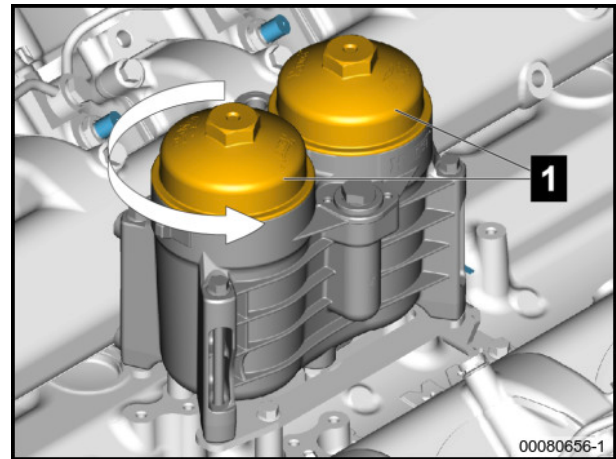

## Removing the fuel filter

- ▶ Unscrew the cover **1** using the size 36 socket [1]
- ▶ Remove the cover **1** with the fuel filter insert **3** from the KSC housing **4**
- ▶ Remove the fuel filter **3** from the cover **1**
- ▶ Remove the O-ring **2**
- ▶ Clean the sealing surfaces

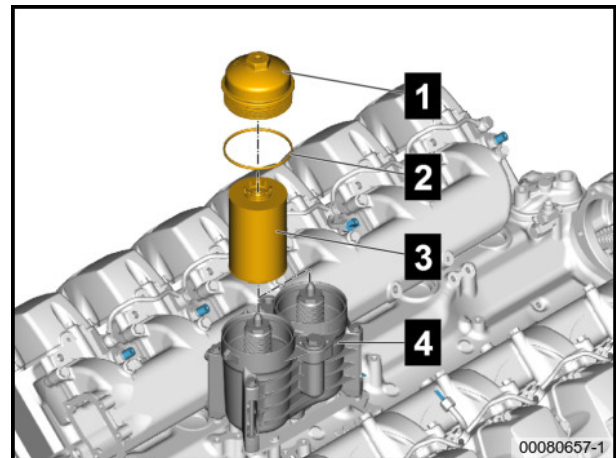

## Installing the fuel filter insert

### Installing the fuel filter

- ▶ Clean the sealing surfaces
- ▶ Apply a thin layer of clean fuel to the new O-ring **2**
- ▶ Fit the new O-ring **2** on the cover **1**
- ▶ Insert the new fuel filter **3** into the cover **1**
- ▶ Screw on the cover **1** and tighten by hand

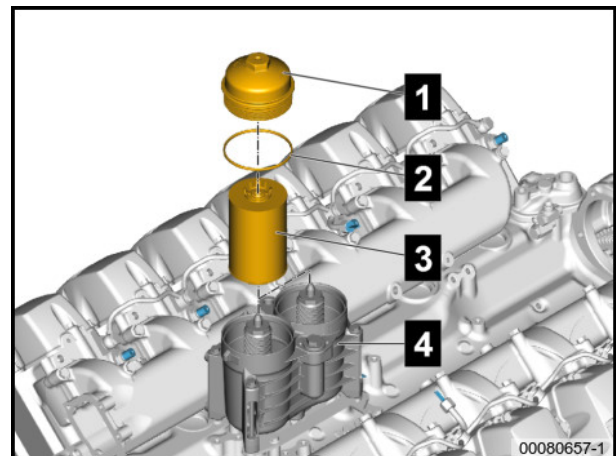

### Attaching the ring union

- ▶ Remove the protective sleeves and end plugs
- ▶ Position the ring union **12** with new sealing rings, and screw in and tighten the hollow screw **11**
- ▶ Screw in the ring union **9** with new sealing rings, and screw in and tighten the hollow screw **10**
- ▶ Screw the transition flange **8** in with a new sealing ring and then tighten
- ▶ Screw in and tighten the DW swivel fitting **7**
- ▶ Screw the GE union **6** in with a new sealing ring and then tighten
- ▶ Position the ring unions **3** and **5** with new sealing rings, and screw in and tighten the hollow screw **4**
- ▶ Position the ring union **13** with new sealing rings, and screw in and tighten the hollow screw **2**
- ▶ Screw in the screw plug **1** with the new seal and tighten it

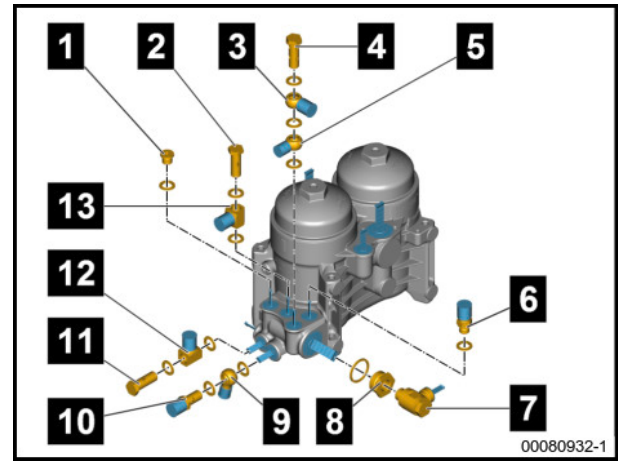

### Attaching the ring union

- ▶ Remove the protective sleeves and end plugs
- ▶ Screw in and tighten the GE connection **8** with a new sealing ring
- ▶ Position the ring union **6** with new sealing rings, and screw in and tighten the hollow screw **7**
- ▶ Screw the transition flange **5** in with a new sealing ring and then tighten
- ▶ Position the ring union **4** with new sealing rings, and screw in and tighten the hollow screw **3**
- ▶ Screw the transition flange **9** in with a new sealing ring and then tighten
- ▶ Position the ring union **1** with new sealing rings, and screw in and tighten the hollow screw **2**

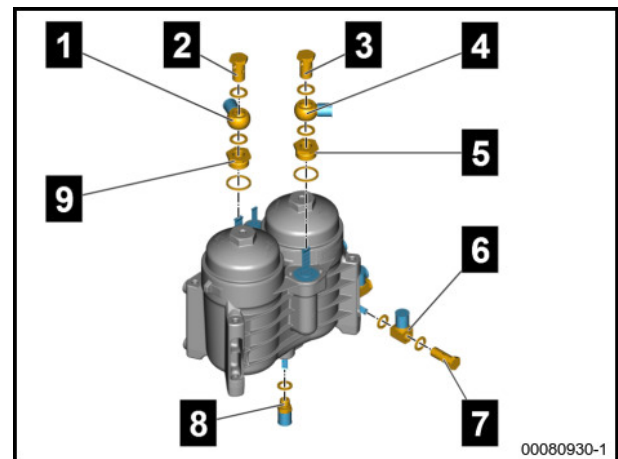

**Attaching the fuel line KSC - HDPPE front**

- ▶ Remove end plugs and protective sleeves
- ▶ Position the fuel line **1**
- ▶ Screw on and then tighten the fuel line retaining nut **1**

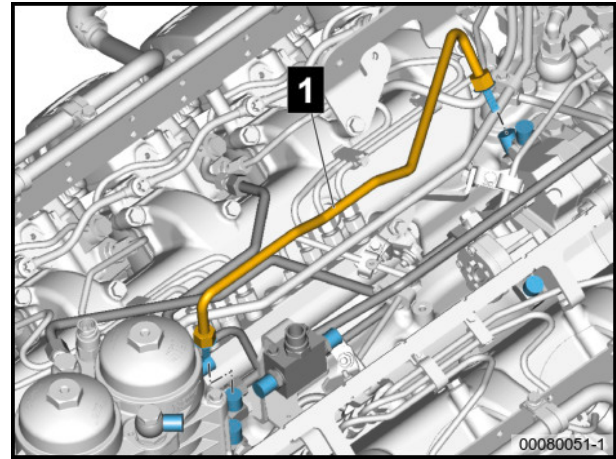
**Attaching the fuel line, return HDPPE front - KSC**

- ▶ Remove end plugs and protective sleeves
- ▶ Position the fuel line **1**
- ▶ Screw on and then tighten the fuel line retaining nut **1**

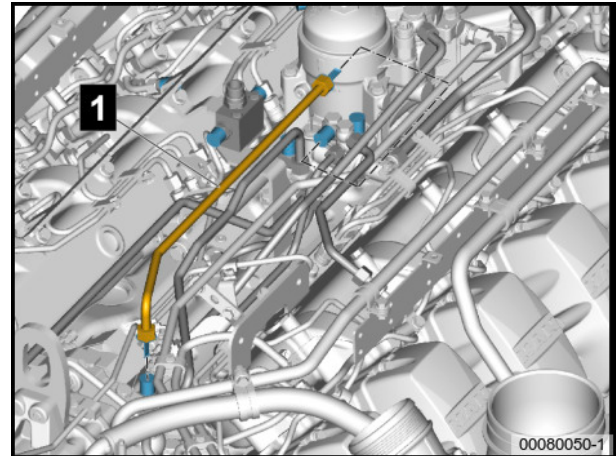
**Attaching the fuel line KSC - HDPPE rear**

- ▶ Remove end plugs and protective sleeves
- ▶ Position the fuel line **1**
- ▶ Screw on and then tighten the fuel line retaining nut **1**

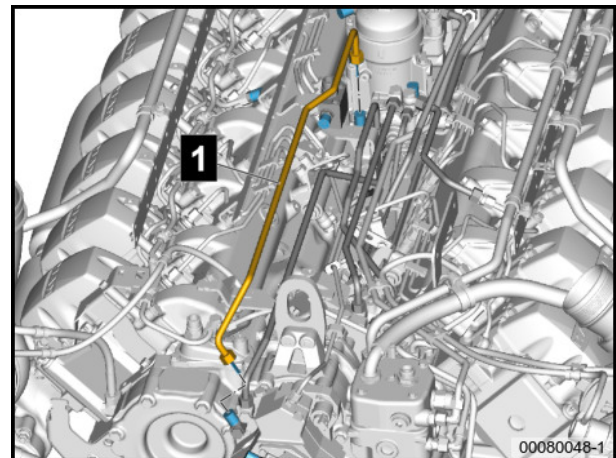
**Attaching the fuel line connection, FPPE front**

- ▶ Remove the end plug and protective sleeve
- ▶ Position the fuel line **1**
- ▶ Screw on and then tighten the fuel line retaining nut **1**

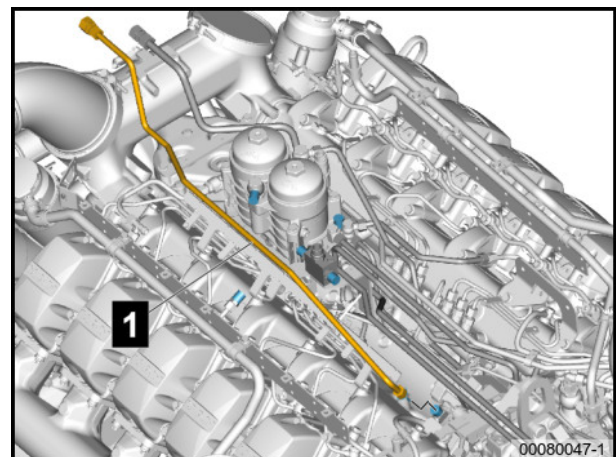

## Installing the fuel return line

### Attaching the fuel return line

- ▶ Remove end plugs and caps
- ▶ Attach the fuel return line **1** with new sealing rings
- ▶ Screw in the hollow screws **2** with new sealing rings and then tighten

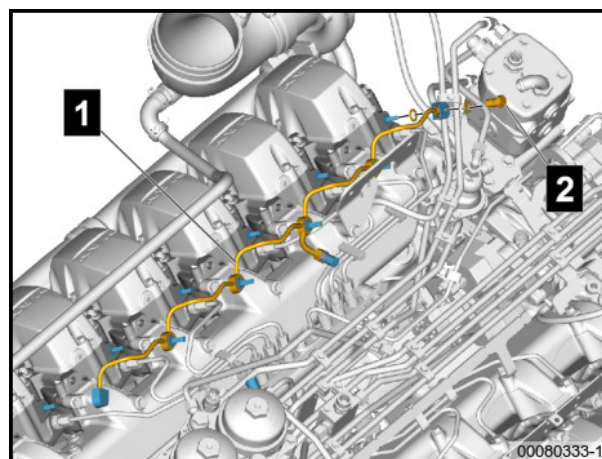

### Attaching the fuel line

- ▶ Remove the protective sleeves and end plugs
- ▶ Position the fuel line **1**
- ▶ Screw on and tighten the retaining nuts **2**

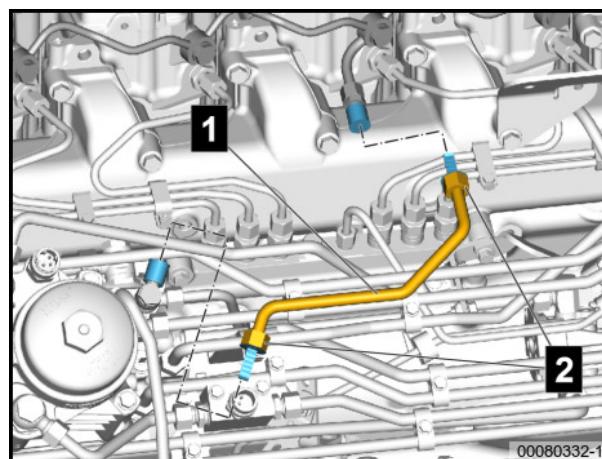

### Attaching the dual clamp

- ▶ Place the dual clamp **3** at the marked position and close
- ▶ Position the cover plates **2** and screw in the mounting bolt **1**
- ▶ Position the cover plate **4**, attach and tighten the mounting nut **5**

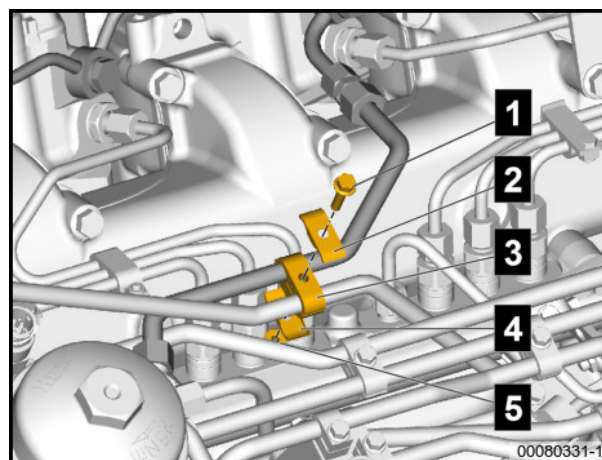

### Attaching the injector cable harness bracket

- ▶ Position the bracket **4** with the bushings **5**
- ▶ Screw in and tighten the mounting bolts **3**
- ▶ Insert the mounting bolts **2** with washers **1** and screw the mounting nuts **6** in and tighten

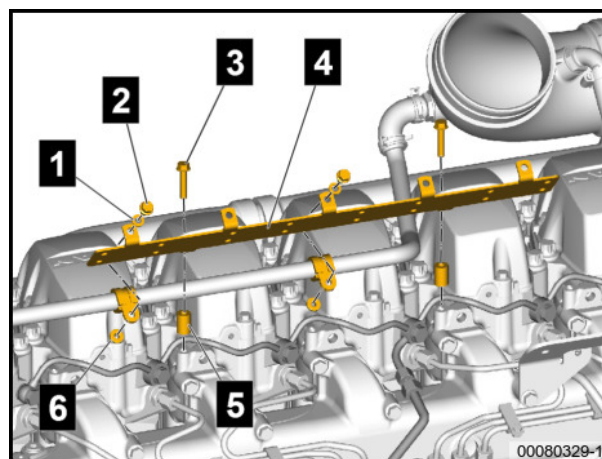

## Removing the injection pressure line

### Removing cable harness bracket

- ▶ Unscrew the mounting bolt **4**
- ▶ Unscrew mounting bolts **3** and **7** with washers
- ▶ Remove the bracket for cable harness **1**
- ▶ Loosen the fasteners **5** and **6** in the bracket **2**
- ▶ Remove the bracket **2**

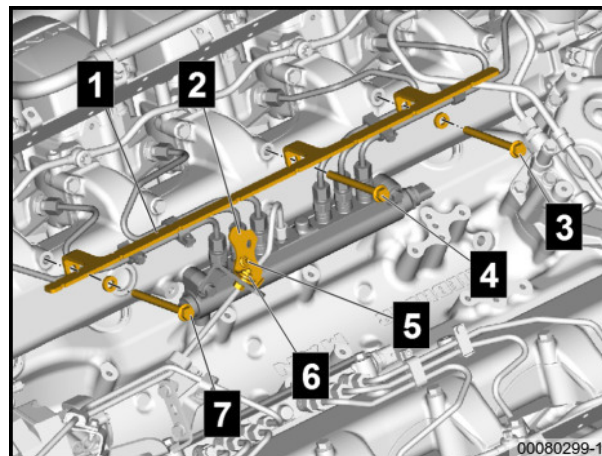

## Removing the injection pressure line

### Undoing the high-pressure line

#### ENVIRONMENTAL WARNING

Collect any remaining fuel that escapes in a suitable container.

- ▶ Assemble the special tool, consisting of a handle [6], ratchet insert [5], angle extension [4] and a socket (size 19) [3]
- ▶ Unscrew the retaining nuts of the high-pressure line set **1** and **2** using the special tool
- ▶ Loosen the rail mounting bolts **3** and tighten by hand

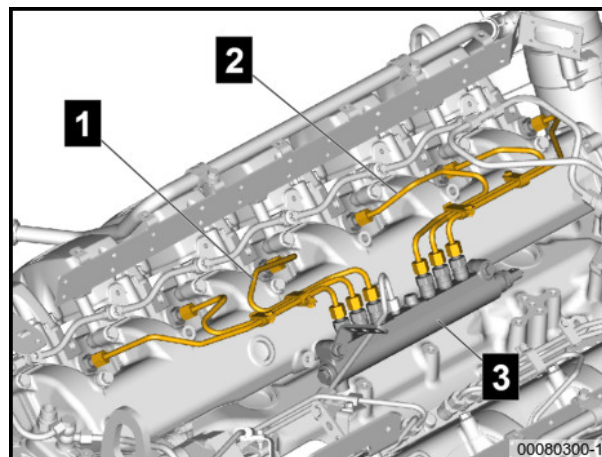

### Detaching the high-pressure lines

- ▶ Remove the high-pressure line set from cylinders 7 to 9 **1** and close off with end plugs [2]
- ▶ Close off the connections in the rail and pressure pipe connector using protective sleeves [1]
- ▶ Repeat the work step for the high-pressure line set on cylinders 10 to 12

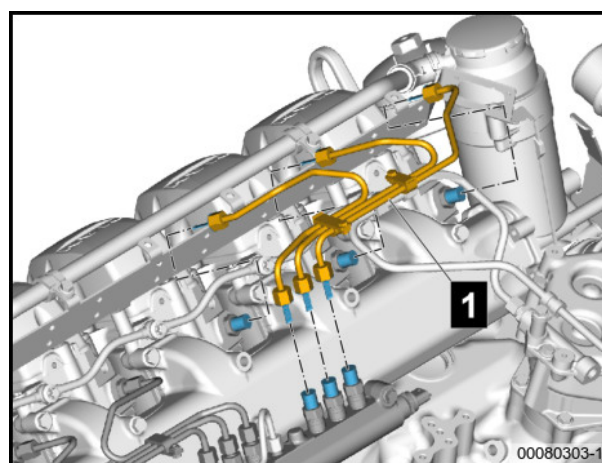

## Installing the high-pressure lines

### Positioning the high-pressure lines

- ▶ Remove the protective sleeves [1] from the connections in the rail and pressure pipe connector
- ▶ Remove the end plugs from the high-pressure line set for cylinders 7 to 9 **1**
- ▶ Position the high-pressure line set for cylinders 7 to 9 **1** and then screw on the retaining nuts and tighten by hand
- ▶ Repeat the work step for the high-pressure line set on cylinders 10 to 12

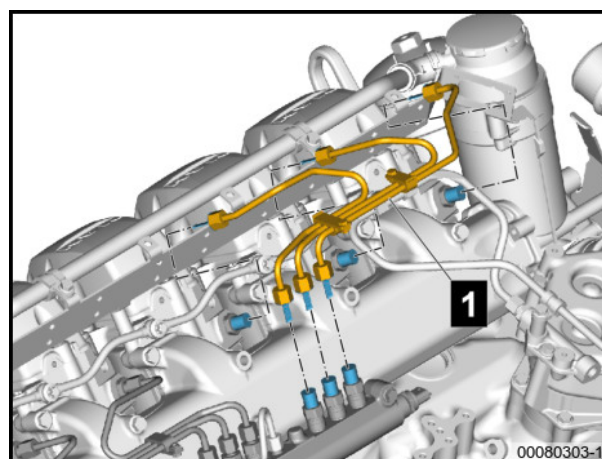

### Attaching the fuel line from the rail to the collector

- ▶ Attach the rail pressure pipe **1** together with the bracket **4**
- ▶ Screw the mounting bolts **2** and **3** in as marked and tighten by hand

For final tightening of rail mounting bolts **2** and **3** on the air distributor pipe, see Removing/installing the injection pressure lines

- ▶ Removing/installing the injection pressure line (right), Page 350

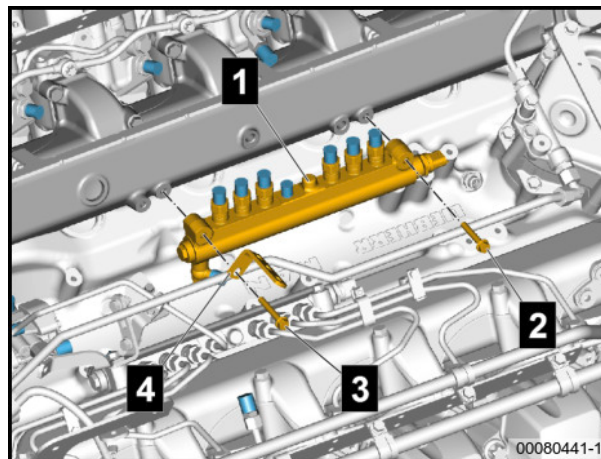

### Connecting the rail pressure sensor electrical connection

- ▶ Plug the electrical plug connector **1** in, pressing until the spring shackle **2** engages
- ▶ Carefully pull on the electrical plug connector **1** and check that it is locked in place (the electrical plug connector must not come loose)

If the electrical plug connector **1** comes loose, unplug the electrical plug connector **1** and attach it again.

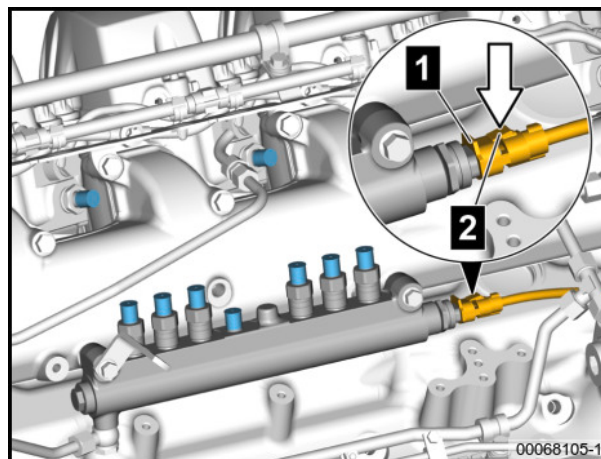

#### 5.2.1.5 Removing/installing the rail (right)

##### Additional measures

- ▶ Removing/installing the injection pressure line (right), Page 350
- ▶ Removing/installing the pump - rail CR pressure line, Page 340

**NOTICE****Risk of injury due to leaks**

Fuel may escape from leaking high-pressure lines at high pressure.

For this reason:

- Carefully inspect the high-pressure lines for damage and deformation of the sealing cone before re-installation.
- Check the high-pressure lines for crushing and deformation.
- Replace damaged high-pressure lines.
- Fit the high-pressure lines so they are free of tension.
- After fitting, check the lines for leaks using MAN-cats® DBV Test.

**Tip for users**

In order to ensure that the correct protective sleeve is used, the designation (e.g. Z 14 x 15) is stamped on it.

**ENVIRONMENTAL WARNING**

Collect any fuel that escapes in a suitable container.

**Special tools**

1

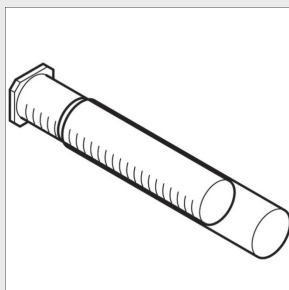
**Storage sleeve**

09.81020-1000

Quantity 12

Keep the injector in a safe place.

2

**End plug**

81.96002-0520

Quantity 12

330L28 Plugging the injector bore on the cylinder head

3

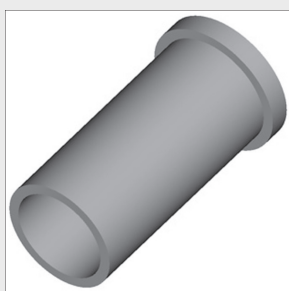
**Protective sleeve**

81.96002-0522

Quantity 12

Plugging the injector nozzle

4

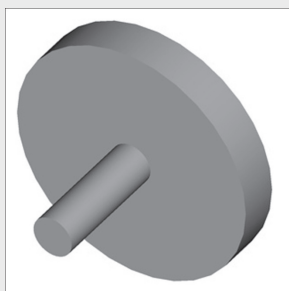
**Protective sleeve**

81.96002-0523

Quantity 12

B43 Plugging the injector feed bore

Observe the safety instructions. Follow the instructions to the letter and proceed cautiously to prevent accidents, personal injury and material damage. Before commencing work, ensure that the latest documentation is used.

## Installing the front high-pressure pump

### Installing the driver sleeve

- ▶ Attach the locking ring **1** to the driver sleeve **1** with locking ring pliers [2]
- ▶ Insert the drive shaft into the driver sleeve **2**

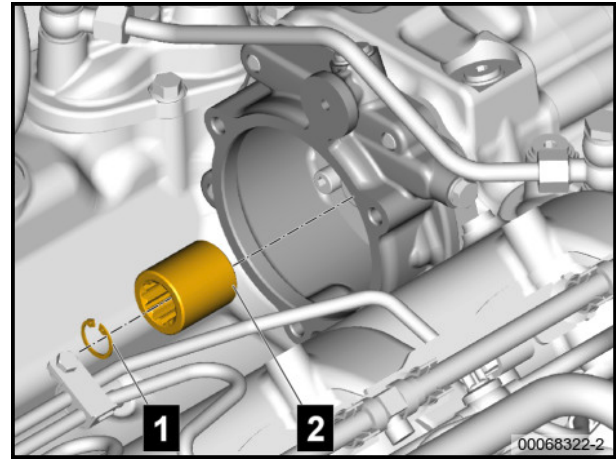

### Installing the slave high-pressure pump

- ▶ Insert the slave high-pressure pump **1** with new O-rings **2** and **3**
- ▶ Screw in and tighten the mounting bolts **4**

Mounting bolt, high-M10x50-10.9.... ... 60 Nm  
pressure pump on +10  
front drive housing..

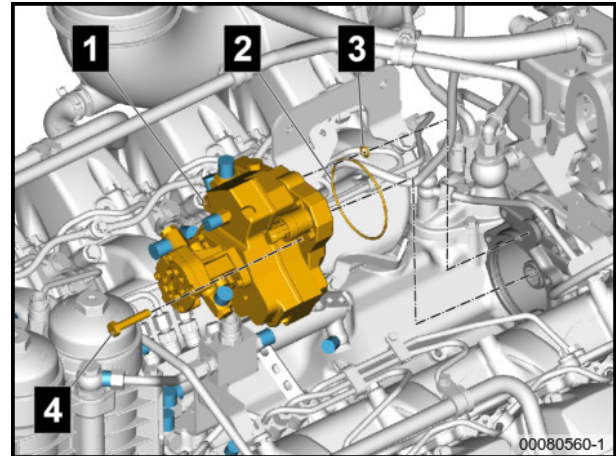

### Attaching the air compressor return line

- ▶ Position the coolant line **7**
- ▶ Screw on and tighten retaining nuts **6** and **8**
- ▶ Place the dual clamp **4** at the marked position and close
- ▶ Position the cover plate **2** on the dual clamp **4** and insert the mounting bolt **1**
- ▶ Position the cover plate **3**, attach and tighten the mounting nut **5**

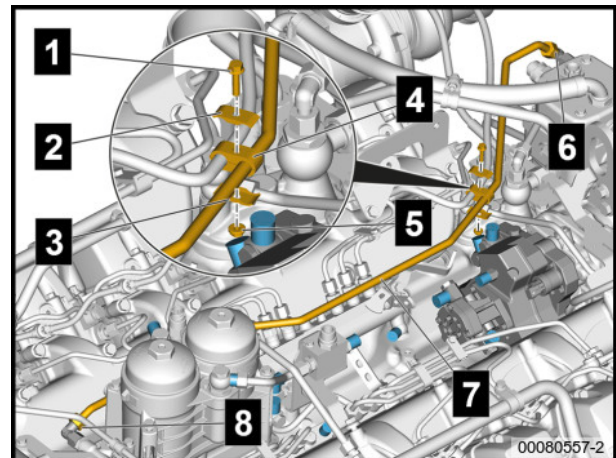

### Attaching the metering unit electrical connection

- ▶ Connect and secure the electrical connection **2** to the metering unit **1**

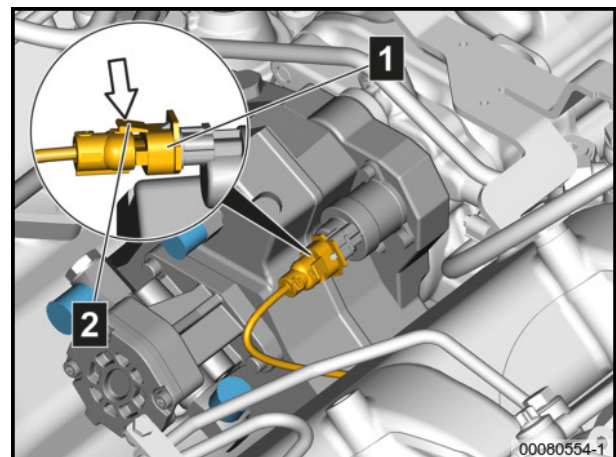

## 5.3.1.2 Removing/installing the high pressure pump (rear)

### Installing the fuel supply pump

- ▶ Insert the coupling element **1** and the new O-ring **2** into the fuel pump **4**
- ▶ Insert the fuel supply pump **4**
- ▶ Assemble the special tool, consisting of the torque wrench [10], ratchet insert [9], extension [8] and screwdriver bit size TX 30 [7]
- ▶ Screw in the mounting bolts **3**
- ▶ Tighten mounting bolts **3** with the special tool

Mounting bolt, fuel supply pump on high-pressure pump..... M6 x 20 T30 - ..... 8 Nm 6.3.....

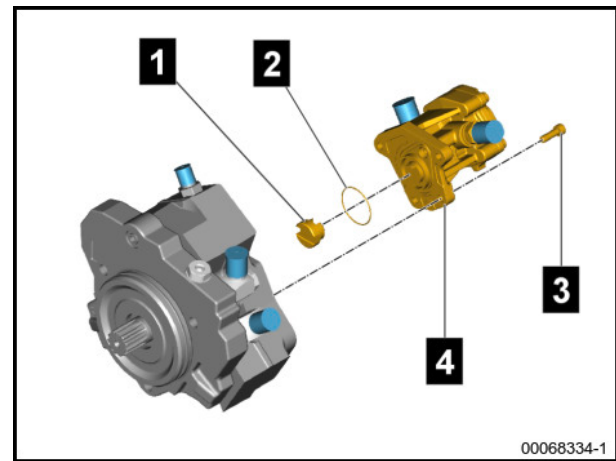

### Installing the proportional valve

#### Tip for users

If using micro-encapsulated bolts, the time between the tightening stages must not exceed 2 minutes.

- ▶ Insert metering unit **1** with a slight right/left turn into the high-pressure pump
- ▶ Align the proportional valve **1** as marked
- ▶ Assemble the special tool, consisting of the torque wrench [10], ratchet insert [9], extension [8] and screwdriver bit size TX 25 [6]
- ▶ Screw in the mounting bolts **2**
- ▶ Tighten mounting bolts **2** to 1st torque

Mounting bolt, proportional valve on T25-6.3..... M5x20 1. Torque.. 3 Nm high-pressure pump..

- ▶ Tighten the mounting bolts **2** to final torque

Mounting bolt, proportional valve on high-pressure pump..... M5x20 Final 6 Nm T25-6.3.... tightening....

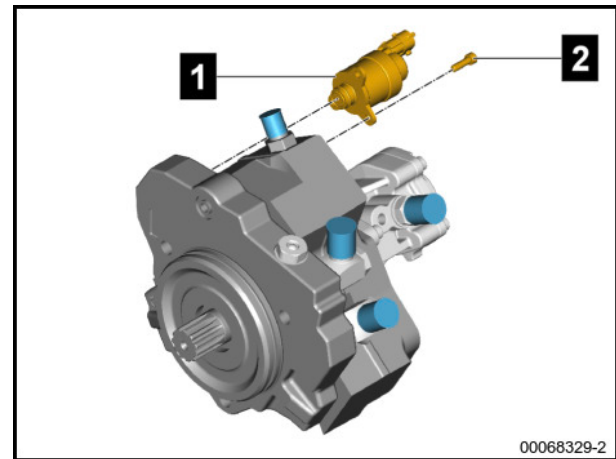

**Special tools**

1

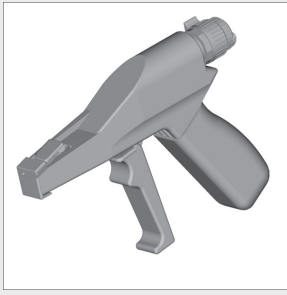

**Cable tie pliers**  
Quantity 1

08.02960-0100

**Removing the console for the control units**

**Detaching the interface connector bracket**

- ▶ Mark the installation position of the cable ties
- ▶ Disconnect the cable ties
- ▶ Unscrew the mounting bolts **2** and remove along with the bushings **3**
- ▶ Open and secure the interface connector bracket **1** with cable harness

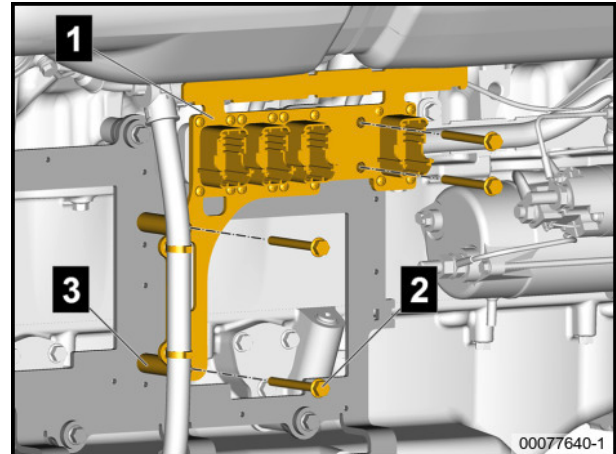

**Detaching the console for the control units**

- ▶ Mark the installation position of mounting bolts **5** and **6**
- ▶ Remove the mounting bolts **5** and **6**
- ▶ Remove the console **1** with rubber bearings **3**, **4** and bushings **2**, **7**

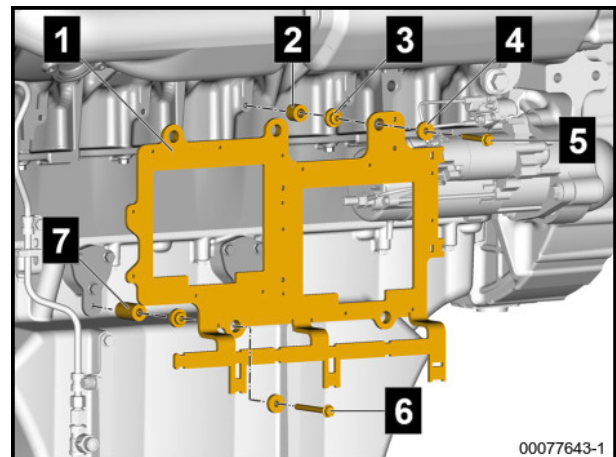

**Installing the console for the control units**

**Attaching the console for the control units**

- ▶ Apply a thin layer of Loctite 270 to the threads of the new mounting bolts **5** and **6**
- ▶ Position the console **1** with rubber bearings **3**, **4** and bushings **2**, **7**
- ▶ Screw the mounting bolts **5** and **6** in as marked and tighten

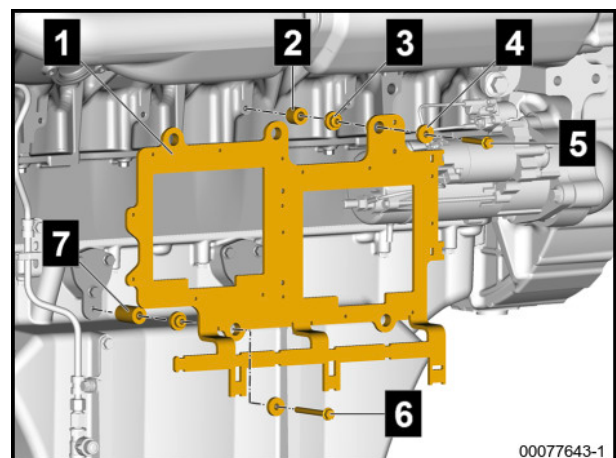

### Detaching coolant feed lines

- ▶ Loosen the retaining nuts **1** and **3**
- ▶ Detach the coolant feed lines **2**

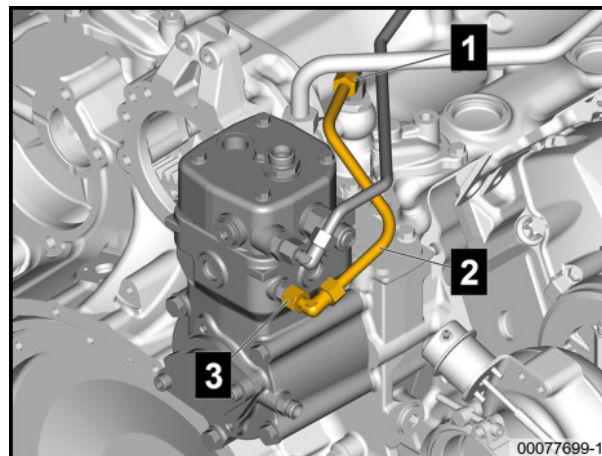

### Detaching the coolant return lines

- ▶ Mark the installation position of the dual clamps
- ▶ Remove the dual clamps
- ▶ Loosen the retaining nut on the WV connector **1**
- ▶ Remove the coolant return line **2** from the air compressor

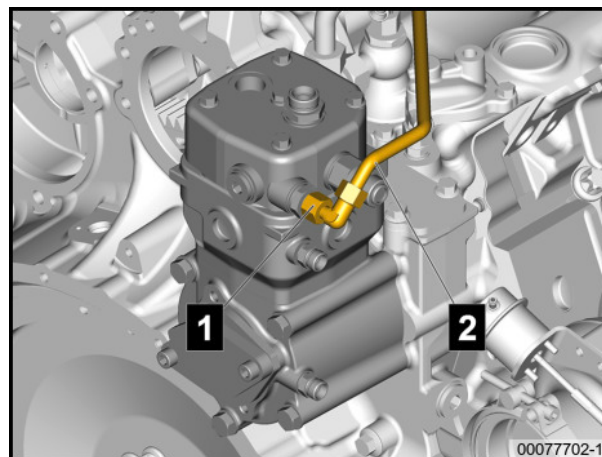

### Detaching the air compressor

#### ⚠ CAUTION

#### Danger of injury due to heavy components

For this reason:

- Remove the air compressor with support
- ▶ Unscrew and remove the mounting bolts **1** with washers
  - ▶ Remove the air compressor **2**
  - ▶ Remove the O-ring **3** from the air compressor **2**
  - ▶ Clean the sealing surfaces

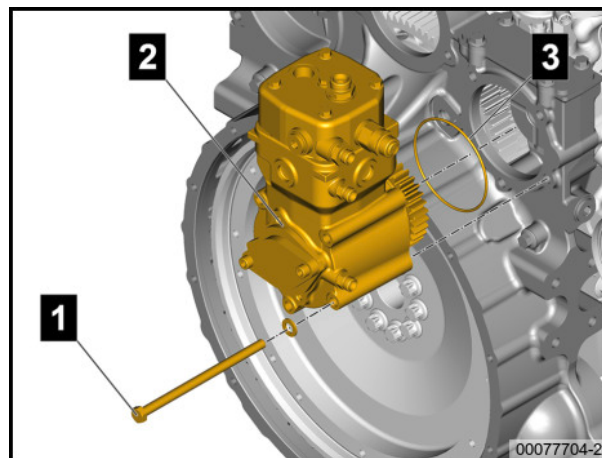

### Installing the 1-cylinder air compressor

#### Attaching the air compressor

#### ⚠ CAUTION

#### Danger of injury due to heavy components

For this reason:

- Install the air compressor with support
- ▶ Clean the sealing surfaces
  - ▶ Apply a thin layer of installation lubricant P80 to the new O-ring **3**
  - ▶ Insert new O-ring **3** in the groove in the air compressor **2**

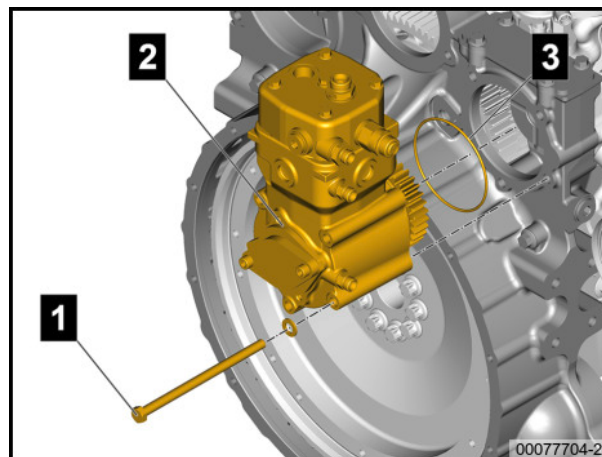

### Attaching the bearing flange

- ▶ Clean the sealing surfaces
- ▶ Apply a thin layer of clean engine oil to the bearing flange
- ▶ Fit a new O-ring **1** on the bearing flange **2**
- ▶ Insert the bearing flange **2** into the air compressor housing in alignment with the marking

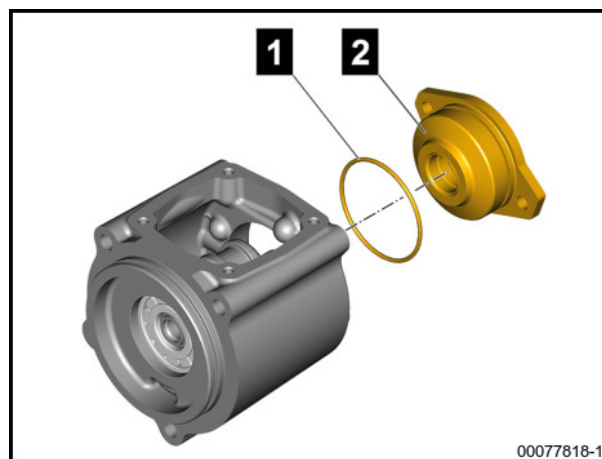

### Attaching the disassembly device

- ▶ Rotate the crankshaft to the installation position
- ▶ Place the disassembly device **1** on the air compressor
- ▶ Screw in and tighten the mounting bolts **2**
- ▶ Clamp the disassembly device [1] **1** in a vice

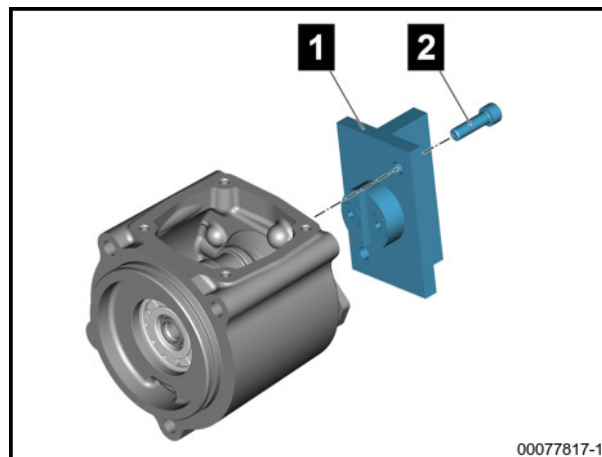

### Attaching the connecting rod

- ▶ Apply a thin layer of clean engine oil to the connecting rod **2** and connecting rod bearing cap **4**
- ▶ Place the connecting rod **2** on the connecting rod bearing **4** by means of the cylindrical pins **3**
- ▶ Screw in and tighten the mounting bolts **1**

Connecting rod M8x38..... 1. Torque..... 10 Nm  
mounting bolts.....

Connecting rod M8x38..... Final 90°  
mounting bolts..... tightening.....

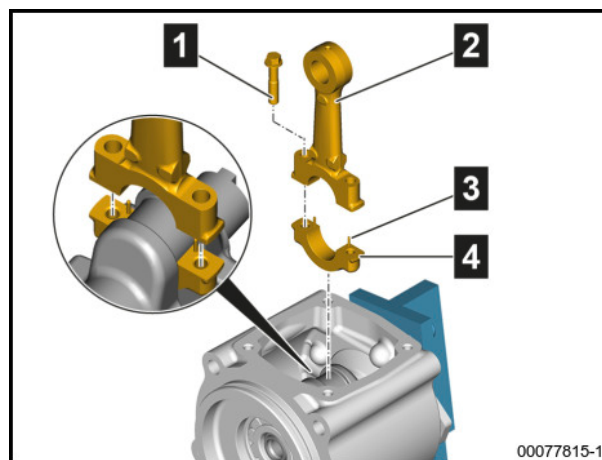

### Attaching the piston rings

- ▶ Carefully clean the piston ring grooves of the piston **2**
- ▶ Set the piston ring pliers [2] **1** to the piston diameter
- ▶ Using the piston ring pliers [2] **1** install the piston rings **3** on the piston **2** with the TOP marking facing the piston crown in accordance with the marking

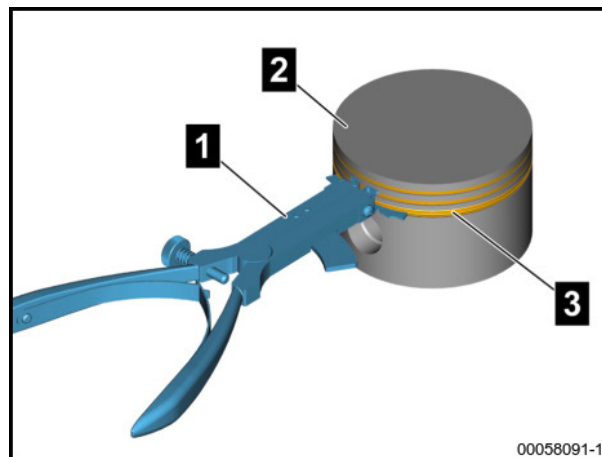

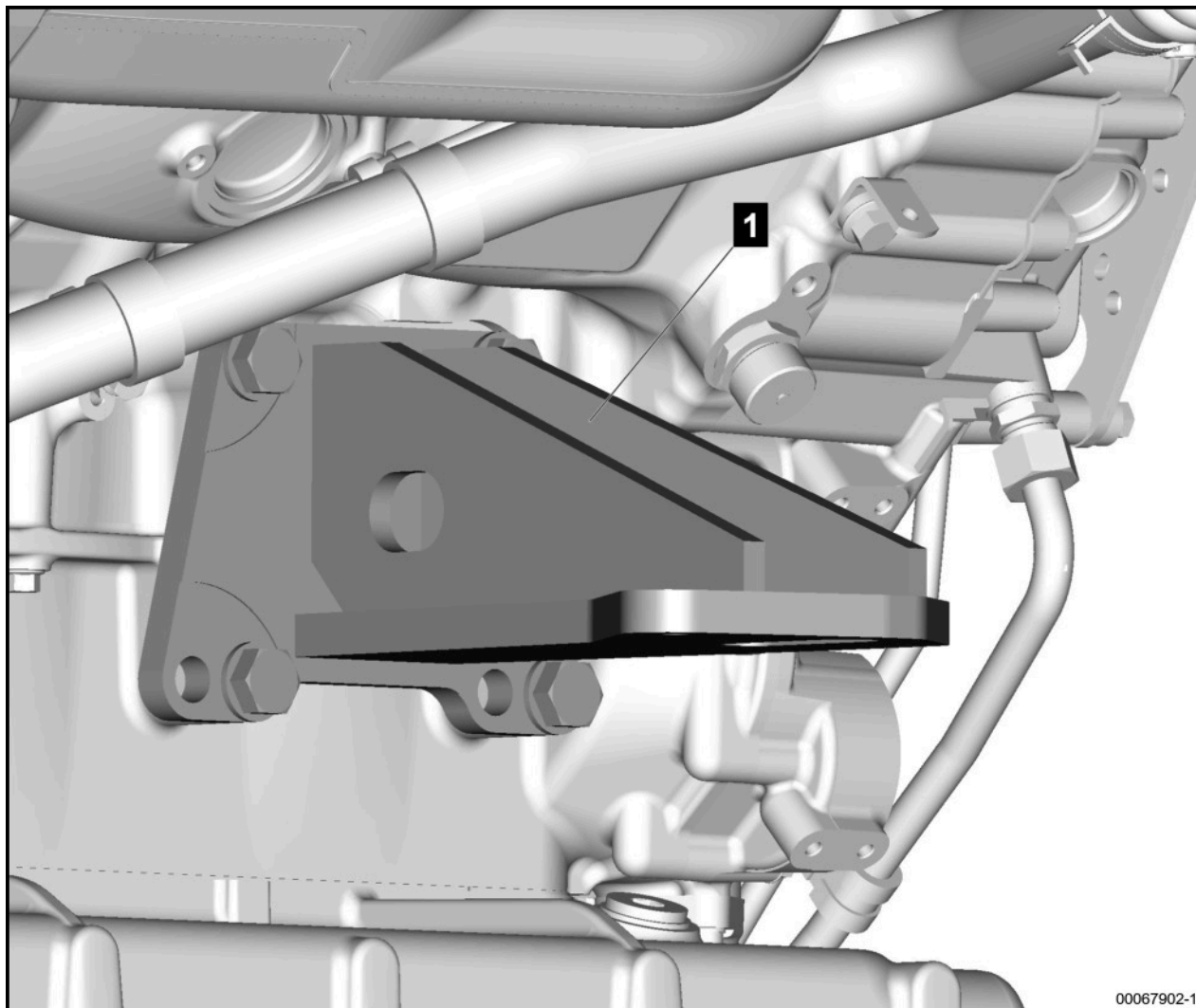

key

**1** Right engine bracket

### Important information

#### **NOTICE**

#### **Risk of material damage from incorrectly tightened bolted connections**

Components will be damaged.

For this reason:

- Only use an impact screwdriver to tighten to max. 50% of the prescribed torque.
- Final tightening must always be performed manually using a torque wrench.



#### **Tip for users**

The repair manual describes the repair method of an engine variant as an example.

Pictures and the corresponding descriptions do not always correspond to the engine being repaired as it was not

possible to take into account all engine variants.

In such cases, plan and execute the repair work accordingly.

1		<p><b>Cable tie pliers</b> <span style="float: right;">08.02960-0100</span>                  Quantity 1                  Tightening and cutting the cable ties</p>
---	---	--

**Removing/installing the camshaft speed sensor** ..... **42**

1		<p><b>Cable tie pliers</b> <span style="float: right;">08.02960-0100</span>                  Quantity 1                  Tightening and cutting the cable ties</p>
---	---	--

**Removing/installing EDC control unit (Electronic Diesel Control)** ..... **45**

1		<p><b>Cable tie pliers</b> <span style="float: right;">08.02960-0100</span>                  Quantity 1                  Tightening and cutting the cable ties</p>
---	--	--

**Removing/installing the alternator** ..... **51**

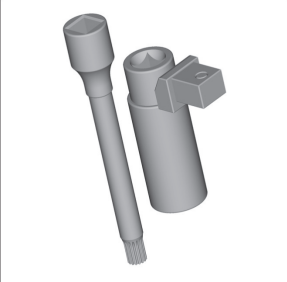
1		<p><b>Special wrench kit</b> <span style="float: right;">80.99603-6029</span>                  Quantity 1                  Attaching and detaching ribbed V-belt disc (alternator) in conjunction with 08.06460-0002</p>
---	---	--



	<p><b>Special wrench kit insert</b> <span style="float: right;">80.99603-0317</span>                  Quantity 1</p>
---	--

	<p><b>Multi-tooth screwdriver insert</b> <span style="float: right;">80.99603-0318</span>                  Quantity 1</p>
---	---

6

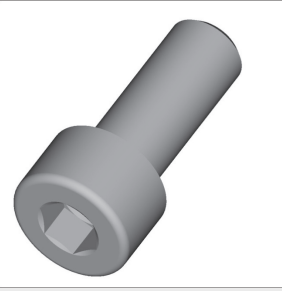
**Stud bolt**

Quantity 1

M8 x 20 - 10.9 - MAN 183-PHR Loosening and tightening the cylinder head bolts

06.02191-0407

7

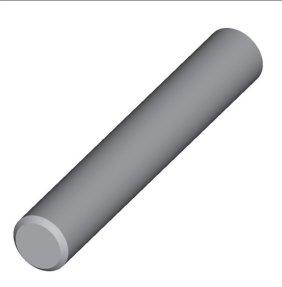
**Connecting pin**

Quantity 1

5.5 x 35 for 3/4" inserts, loosening and tightening the cylinder head bolts

06.22729-0006

8

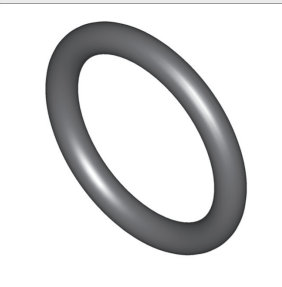
**Rubber ring**

Quantity 1

42 mm rubber ring for 3/4" inserts

08.06142-9006

9

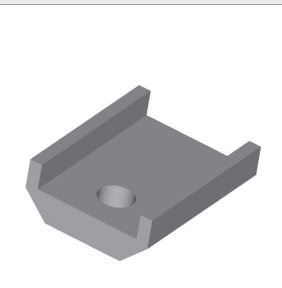
**Guide adapter**

Quantity 1

Component of 80.99606-6101 support for power amplifier, loosening and tightening the cylinder head bolts

80.99606-0552

10

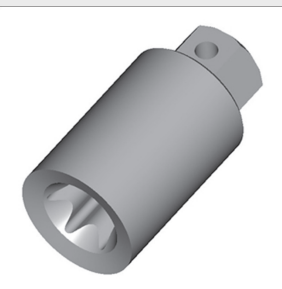
**Socket**

Quantity 1

- Loosening and tightening the cylinder head bolts in conjunction with:

- Socket wrench insert size 22 [1]
- Power amplifier wrench  $i = 1 : 3.3$  [2]
- Support [3]
- Angle gage [4]
- Holder [5]
- Stud bolt [6]
- Connecting pin [7]
- Rubber ring 42 mm [8]
- Guide adapter [9]

80.99603-0327

2

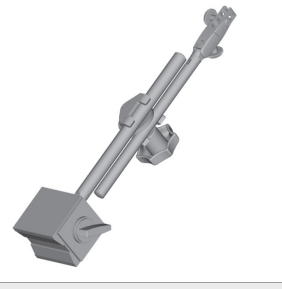
**Dial gage holder**

08.71082-0005

Quantity 1

Adjusting the pre-load of the EGR adjusting cylinder within the intake / exhaust system

3

**Measuring tip**

80.99605-0197

Quantity 1

Adjusting the pre-loading of the EGR adjusting cylinder within the intake / exhaust system in conjunction with 08.71082-0005, 80.71000-3217

4

**Settling tool**

80.99622-0052

Quantity 1

Setting tool

- Positioning the bearing shell on a cracked connecting rod

5

**Centering pin**

80.99617-0020

Quantity 1

Guide mandrels

6

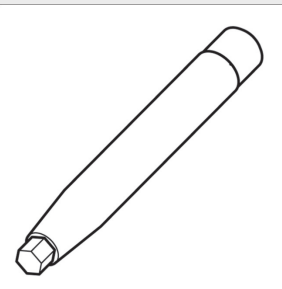
**Centering pin**

80.99617-0220

Quantity 1

Ø18.8 x 145 external thread M18x1,5 x 18 external hex  
SW10 x 9

- Removing/installing the crankshaft in conjunction with:
- Centering pin [5]

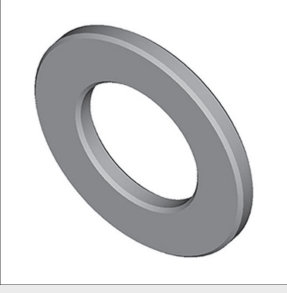
7		<p><b>Washer</b>                  Quantity 1                  Washer</p> <ul style="list-style-type: none"> <li>• Checking the cylinder liner protrusion in conjunction with:</li> <li>• Dial gage holder [3]</li> <li>• Dial gage [4]</li> <li>• Measuring plate [5]</li> <li>• Bolt [6]</li> </ul>	06.15013-0417
---	---	--	---------------

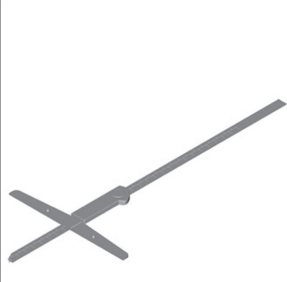
8		<p><b>Depth gage</b>                  Quantity 1                  Check the dimensions of the impeller to the coolant pump housing</p>	08.71195-9003
---	---	--	---------------

**Removing/installing the oil nozzle** ..... 278

**Removing/installing the crankcase ventilation (left)** ..... 280

1		<p><b>Hose clip pliers</b>                  Quantity 1                  Hose clamp pliers, angled version</p> <ul style="list-style-type: none"> <li>• Installing/removing spring band clamps</li> </ul>	80.99625-0073
---	--	--	---------------

**Removing/installing the crankcase ventilation (right)** ..... 281

1		<p><b>Hose clip pliers</b>                  Quantity 1                  Hose clamp pliers, angled version</p> <ul style="list-style-type: none"> <li>• Installing/removing spring band clamps</li> </ul>	80.99625-0073
---	---	--	---------------

**Removing/installing the crankcase ventilation oil separator (left)** ..... 283

**Removing/installing the crankcase ventilation oil separator (right)** ..... 285

**Intake fitting, left turbocharger** ..... 288

**Intake fitting, right turbocharger** ..... 289

**Removing/installing the turbocharger (left)** ..... 293

6

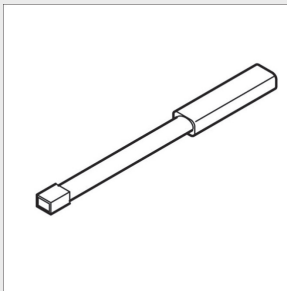
**Handle**

08.06460-0002

Quantity 1

Attaching and detaching ribbed V-belt disc (alternator) in conjunction with 80.99603-6029

7

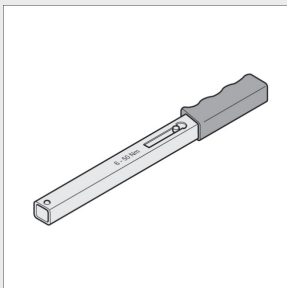
**Torque wrench**

08.06450-0006

Quantity 1

Torque wrench 6-50 Nm square drive 3/8" square for insertion tool 9x12 adjust to valve clearance, tighten the lock nut of the adjusting screw

**Removing/installing the rail (left)**

355

1

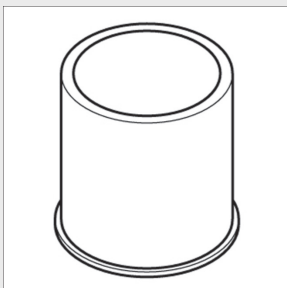
**Protective sleeve**

81.96002-0513

Quantity 1

Protective sleeve GPN 200 Z16 x 8

2

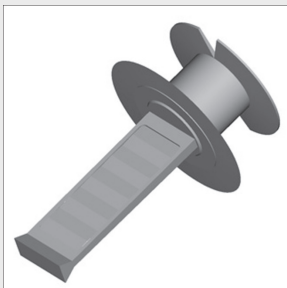
**End plug**

81.96002-0519

Quantity 1

GPN 330L16, closing the hole of the pressure pipe socket in the common rail system

3

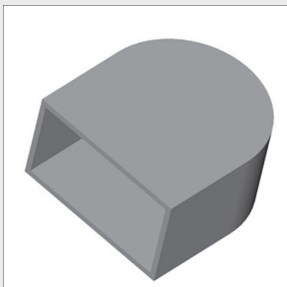
**Cap**

81.96002-0518

Quantity 1

GPN 695 BE 10, closing the hollow screw connections in the common rail system

**Removing/installing the rail (right)**

359

CLICK HERE TO **DOWNLOAD** THE COMPLETE MANUAL

- Thank you very much for reading the preview of the manual.
- You can download the complete manual from: [www.heydownloads.com](http://www.heydownloads.com) by clicking the link below



- Please note: If there is no response to CLICKING the link, please download this PDF first and then click on it.

CLICK HERE TO **DOWNLOAD** THE COMPLETE MANUAL