

**710K
Backhoe Loader
Repair Manual**

(PIN: 1T0710KX__D219607—)

REPAIR TECHNICAL MANUAL

**710K Backhoe Loader
(PIN: 1T0710KX__D219607—)**

TM12512 15MAY19 (ENGLISH)

**Worldwide Construction
And Forestry Division**
PRINTED IN U.S.A.

CLICK HERE TO **DOWNLOAD** THE COMPLETE MANUAL

- Thank you very much for reading the preview of the manual.
- You can download the complete manual from: www.heydownloads.com by clicking the link below



- Please note: If there is no response to CLICKING the link, please download this PDF first and then click on it.

CLICK HERE TO **DOWNLOAD** THE COMPLETE MANUAL

Avoid High-Pressure Fluids

Inspect hydraulic hoses periodically – at least once per year – for leakage, kinking, cuts, cracks, abrasion, blisters, corrosion, exposed wire braid or any other signs of wear or damage.

Replace worn or damaged hose assemblies immediately with John Deere approved replacement parts.

Escaping fluid under pressure can penetrate the skin causing serious injury.

Avoid the hazard by relieving pressure before disconnecting hydraulic or other lines. Tighten all connections before applying pressure.

Search for leaks with a piece of cardboard. Protect hands and body from high-pressure fluids.

If an accident occurs, see a doctor immediately. Any fluid injected into the skin must be surgically removed within a few hours or gangrene may result. Doctors unfamiliar

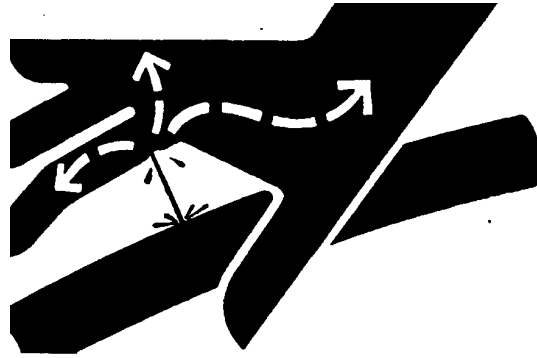

with this type of injury should reference a knowledgeable medical source. Such information is available in English from Deere & Company Medical Department in Moline, Illinois, U.S.A., by calling 1-800-822-8262 or +1 309-748-5636.

X9811 —UN—23AUG88

DX,FLUID -19-12OCT11-1/1

Avoid High-Pressure Oils

This machine uses a high-pressure hydraulic system. Escaping oil under pressure can penetrate the skin causing serious injury.

Never search for leaks with your hands. Protect hands. Use a piece of cardboard to find location of escaping oil. Stop engine and relieve pressure before disconnecting lines or working on hydraulic system.

If hydraulic oil penetrates your skin, see a doctor immediately. Injected oil must be removed surgically within hours or gangrene could result. Contact a knowledgeable medical source or the Deere & Company Medical Department in Moline, Illinois, U.S.A.

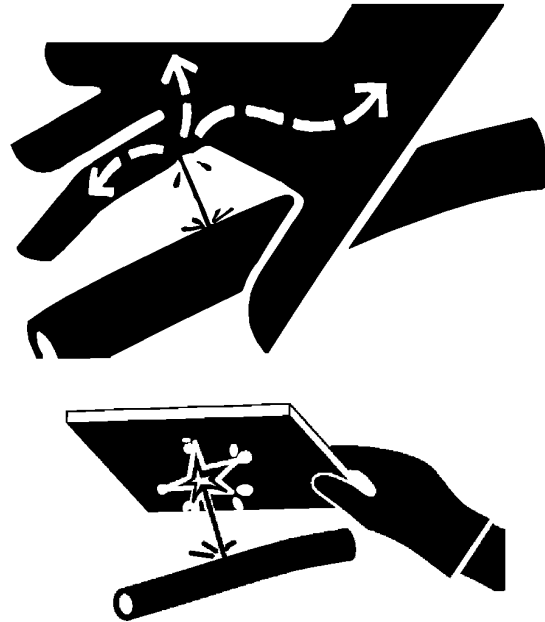

T133509 —UN—15APR13

T133840 —UN—20SEP00

TX,HPOILS -19-20JAN11-1/1

Drive Metal Pins Safely

Always wear protective goggles or safety glasses and other protective equipment before striking hardened parts. Hammering hardened metal parts such as pins and bucket teeth could dislodge chips at high velocity.

Use a soft hammer or a brass bar between hammer and object to prevent chipping.

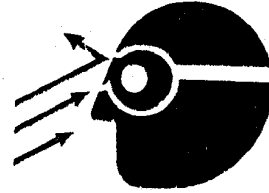

T133738—UN—15APR13

TX,PINS -19-20JAN11-1/1

Service Tires Safely

Explosive separation of a tire and rim parts can cause serious injury or death.

Do not attempt to mount a tire unless you have the proper equipment and experience to perform the job.

Always maintain the correct tire pressure. Do not inflate the tires above the recommended pressure. Never weld or heat a wheel and tire assembly. The heat can cause an increase in air pressure resulting in a tire explosion. Welding can structurally weaken or deform the wheel.

When inflating tires, use a clip-on chuck and extension hose long enough to allow you to stand to one side and NOT in front of or over the tire assembly. Use a safety cage if available.

Check wheels for low pressure, cuts, bubbles, damaged rims or missing lug bolts and nuts.

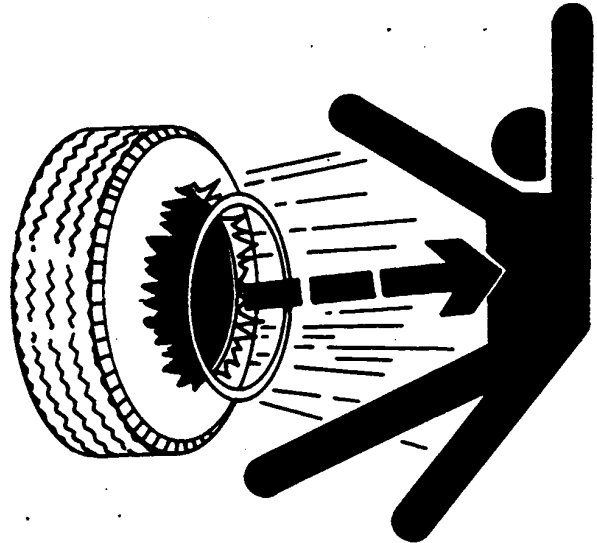

TS211—UN—15APR13

DX,RIM -19-24AUG90-1/1

O-Ring Face Seal Fittings With SAE Inch Hex Nut And Stud End For High Pressure Service Recommendations

O-RING FACE SEAL FITTINGS WITH SAE INCH HEX NUT AND STUD END FOR HIGH PRESSURE, ABOVE 27 600 kPa (276 bar) (4000 psi), TORQUE VALUES—Tolerance is +15 -20% unless otherwise specified

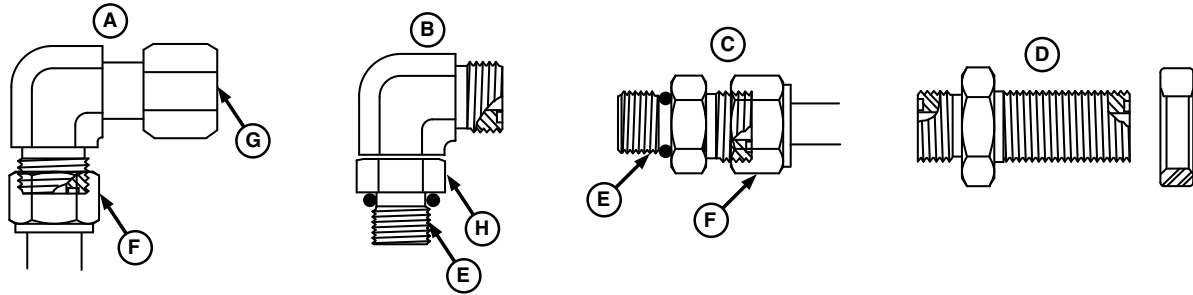

A—90° Swivel Elbow and Tube Nut
 B—90° Adjustable Stud Elbow
 C—Stud Straight and Tube Nut
 D—Bulkhead Union and Nut
 E—Stud End
 F—Tube Nut
 G—Swivel Nut
 H—Hex Nut

Nominal Tube OD or Hose ID			O-Ring Face Seal Hose or Tube Swivel Nut			Bulkhead Nut	
Metric Tube OD	Inch Tube OD or Hose ID		Thread Size	Hex Size	Torque	Hex Size	Torque
mm	Dash Size	mm (in.)	in.	in.	Nm (lb-ft)	in.	Nm (lb-ft)
5	-3	4.78 (0.188)	—	—	—	—	—
6	-4	6.35 (0.250)	9/16-18	11/16	24 (18)	13/16	32 (24)
8	-5	7.92 (0.312)	—	—	—	—	—
10	-6	9.53 (0.375)	11/16-16	13/16	37 (27)	1	42 (31)
12	-8	12.70 (0.500)	13/16-16	15/16	75 (55)	1-1/8	93 (69)
16	-10	15.88 (0.625)	1-14	1-1/8	103 (76)	1-5/16	118 (87)
20	-12	19.05 (0.750)	1-3/16-12	1-3/8	152 (112)	1-1/2	175 (129)
22	-14	22.23 (0.875)	1-3/16-12	—	152 (112)	—	175 (129)
25	-16	25.40 (1.000)	1-7/16-12	1-5/8	214 (158)	1-3/4	247 (182)
32	-20	31.75 (1.250)	1-11/16-12	1-7/8	286 (211)	2	328 (242)
38	-24	38.10 (1.500)	2-12	2-1/4	326 (240)	2-3/8	374 (276)

O-RING STRAIGHT, ADJUSTABLE, AND EXTERNAL HEX PLUG WITH SAE INCH STUD END FOR HIGH PRESSURE, ABOVE 27 600 kPa (276 bar) (4000 psi), TORQUE VALUES—Tolerance is +15 -20% unless otherwise specified

Thread Size	Straight Hex Size ^a	Adjustable Nut Hex Size	Steel or Gray Iron Torque
in.	in.	in.	Nm (lb-ft)
3/8-24	5/8	9/16	18 (13)
7/16-20	5/8	5/8	24 (18)
1/2-20	3/4	11/16	30 (22)
9/16-18	3/4	3/4	37 (27)
3/4-16	7/8	15/16	75 (55)
7/8-14	1-1/16	1-1/16	103 (76)
1-1/16-12	1-1/4	1-3/8	177 (131)
1-3/16-12	1-3/8	1-1/2	231 (170)
1-5/16-12	1-1/2	1-5/8	270 (199)
1-5/8-12	1-3/4	1-7/8	286 (211)
1-7/8-12	2-1/8	2-1/8	326 (240)

^a Straight hex size applies to fittings only and may not be the same as the corresponding plug of the same thread size.

- Inspect fitting and connector sealing surfaces and the O-rings. They must be free of dirt, scratches, nicks, and burrs. O-ring must be free of dirt, cuts, cracks, swelling or flatten condition.

Continued on next page

WS68074,0001B84 -19-28MAR08-1/2

H70406—UN—15APR13

Service Recommendations For O-Ring Boss Fittings With Shoulder

1. Inspect component seal boss seat for dirt or defects.
2. Inspect EOlastic seal (A) for damage. Replace seal or fitting as necessary.

To replace seal, put electrical tape over threads to protect seal. Slide seal over tape and into seal groove of fitting. Remove tape.

3. Tighten fitting to torque value shown on chart.

IMPORTANT: Do not allow hoses to twist when tightening fittings.

NOTE: The L in the Tube Fitting OD Size column indicates "light" designed fitting and the S indicates "heavy" designed fitting.

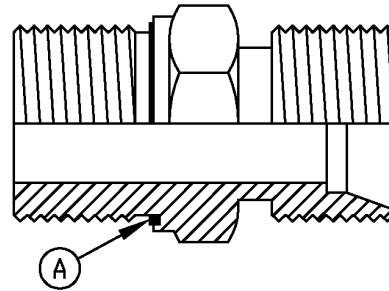

T113957

T113957—UN—06MAR98

Tube Fitting O.D. Size	Metric Thread	Torque Value	
		N-m	lb-ft
6 L	M 10 x 1	20	15
8 L	M 12 x 1.5	30	22
10 L	M 14 x 1.5	45	33
12 L	M 16 x 1.5	60	44
15 L	M 18 x 1.5	80	59
18 L	M 22 x 1.5	130	96
22 L	M 26 x 1.5	190	140
28 L	M 33 x 2	300	221
35 L	M 42 x 2	600	443
42 L	M48 x 2	800	590
6 S	M 12 x 1.5	40	30
8 S	M 14 x 1.5	60	44
10 S	M 16 x 1.5	80	59
12 S	M 18 x 1.5	110	81
14 S	M 20 x 1.5	140	103
16 S	M 22 x 1.5	170	125
20 S	M 27 x 2	250	184
25 S	M 33 x 2	450	332
30 S	M 42 x 2	600	443
38 S	M 48 x 2	800	590

Tube Fitting O.D. Size	Torque Value		
	Inch Size	N-m	lb-ft
6 L	1/8	20	15
8 L	1/4	40	30
10 L	1/4	40	30
12 L	3/8	80	59
15 L	1/2	140	103
18 L	1/2	100	74
22 L	3/4	180	133
28 L	1	300	221
35 L	1-1/4	600	443
42 L	1-1/2	800	590
6 S	1/4	50	37
8 S	1/4	50	37
10 S	3/8	90	66
12 S	3/8	90	66
14 S	1/2	160	118
16 S	1/2	140	103
20 S	3/4	250	184
25 S	1	400	295
30 S	1-1/4	650	479
38 S	1-1/2	800	590

⚠ CAUTION: Tire repair should only be performed by a qualified service technician. Do not attempt to mount or demount a tire unless you have proper equipment and experience to perform job safely. Failure to follow proper procedures when mounting or demounting a tire from a wheel or rim can result in explosive separation of a tire and rim parts, causing serious injury or death

10. Turn tire so valve stem is positioned at 12 o'clock. Use a pressure regulating valve with clip-on chuck (6) and extension hose long enough to allow you to stand to one side and NOT in front of tire while inflating.
11. Use only recommended air pressure. Pressure over this limit can cause an explosion.
12. Add air until side flange of tire slides out against rim.
13. Adjust air pressure to proper specification.

6— Pressure Regulating Valve
With Clip-On Chuck

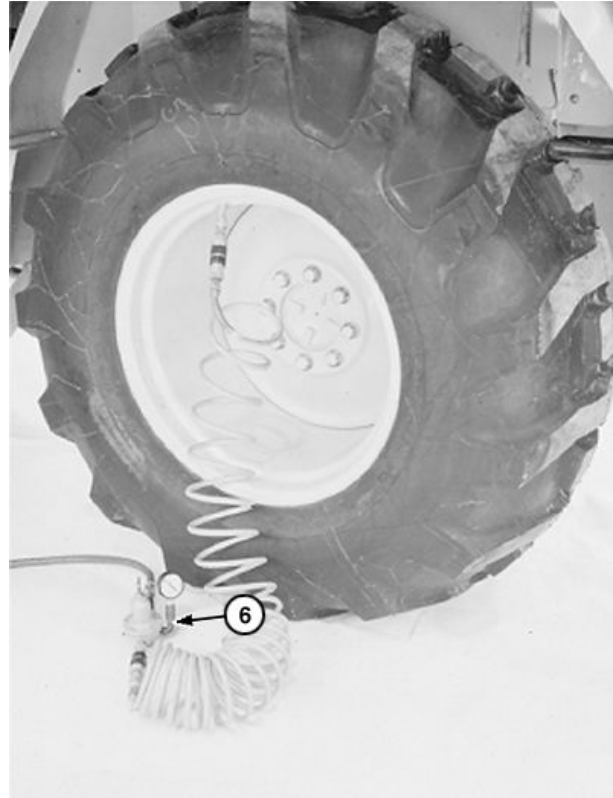

Turn Tire

TX1114144A —UN—11JUN12

DS35042,0001AE9 -19-13JUL12-3/3

Non-Powered Wheel Axles

IMPORTANT: Removing seal ring from king pin will destroy the seal.

8. Remove bearing cone (5) and seal ring (6) from king pin using a knife edge puller.

5— Bearing Cone

6— Seal Ring



King Pin

DF89619,00B51E2 -19-11JUN12-3/6

TX1114375A —UN—22MAY12

9. Remove swivel housing (7).

7— Swivel Housing



Swivel Housing Removal

Continued on next page

DF89619,00B51E2 -19-11JUN12-4/6

TX1114376A —UN—22MAY12

Rear Axle Remove and Install

SPECIFICATIONS

Rear of Machine Weight (approximate)	8163 kg 18 000 lb.
Rear Axle Weight	532 kg 1172 lb.
Mounting Cap Screw Torque	800 N·m 590 lb.-ft.

SERVICE EQUIPMENT AND TOOLS

JT01642A Low Lift Jack

1. Park and prepare machine for service. See Park and Prepare for Service Safely. (Group 0001.)

CAUTION: Prevent possible crushing injury from heavy component. Use appropriate lifting device.

2. Raise and support rear of machine. Position floor stands under main frame.

Specification

Rear of Machine—Weight
(approximate)..... 8163 kg
18 000 lb.

CAUTION: To avoid injury from escaping fluid under pressure, stop engine and relieve pressure in system before disconnecting or connecting hydraulic or other lines. Tighten all connections before applying pressure.

3. Release hydraulic system pressure. See Hydraulic Circuit Pressure Release. (Group 9025-25.)
4. Discharge brake accumulator pressure.

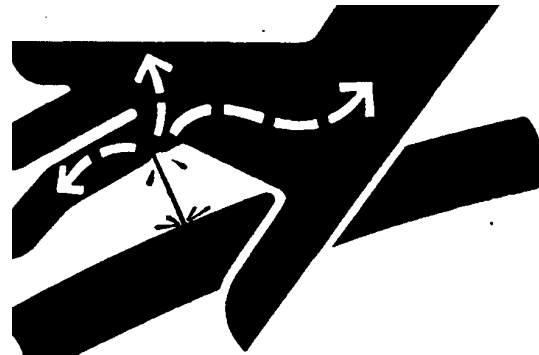

High Pressure Fluids

NOTE: Accumulator may be discharged due to normal leakage through the brake valve when engine is stopped.

- a. Power ignition ON, but do not start engine.
 - b. Pump both brake pedals until low pressure warning light comes on.
 - c. Pump both brake pedals 10 more times to relieve accumulator pressure in brake valve.
5. Remove both rear wheels. See Rear Wheel Assembly Remove and Install. (Group 0110.)
 6. Drain rear axle. See Change Rear Axle Oil. (Operator's Manual.)
 7. Remove rear drive shaft. See Universal Joint and Drive Shaft Remove and Install. (Group 0225.)

Continued on next page

DF89619,00B51ED -19-10SEP12-1/3

X9811 —UN—23AUG88

Axle Shaft, Bearings, and Reduction Gears

22. Drive adjusting pins (62) and bearing cup (63) out of brake housing.

23. Remove O-ring (64).

62— Adjusting Pin (5 used)
63— Bearing Cup

64— O-Ring

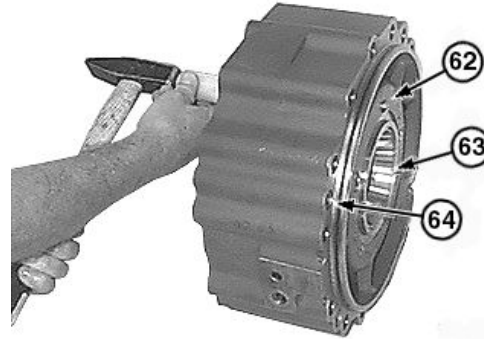

Adjusting Pin Removal

BJ21193,00000FC -19-07SEP16-19/32

TX1120225A —UN—16AUG12

CAUTION: Prevent possible crushing injury from heavy component. Use appropriate lifting device.

24. Remove differential (66) from differential housing (39).

39— Differential Housing

66— Differential

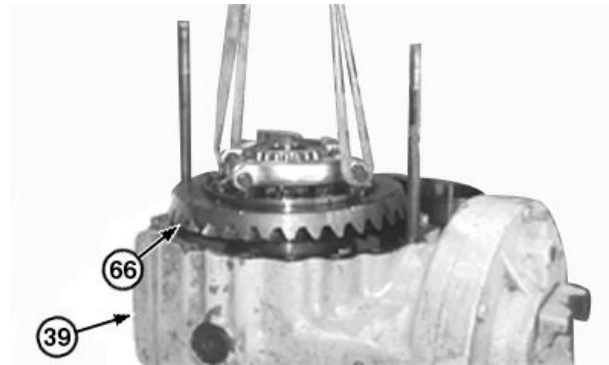

Differential Removal

BJ21193,00000FC -19-07SEP16-20/32

TX1120226A —UN—16AUG12

25. Remove thrust bearing (68).

26. Using a bearing puller from D01047AA 17-1/2—30 Ton Puller Set, remove both bearing cones (69) from differential.

68— Thrust Bearing

69— Bearing Cone (2 used)

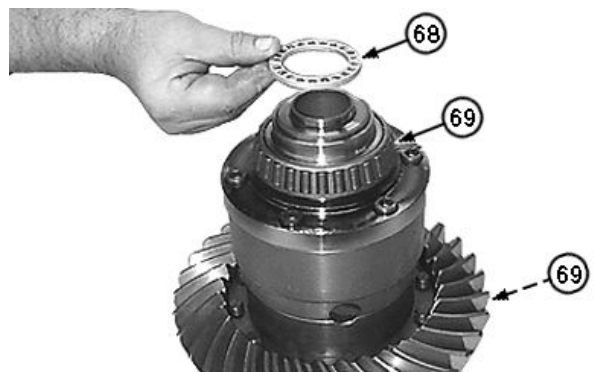

Thrust Bearing Removal

Continued on next page

BJ21193,00000FC -19-07SEP16-21/32

TX1120218A —UN—15AUG12

12. Install friction disks (25) and separator plates (26) starting with a separator plate and alternating with a friction disk.

13. Align separator plates using two guide bolts (27). Install end plate (28).

- | | |
|------------------------------|-------------------------|
| 25— Friction Disk (8 used) | 27— Guide Bolt (2 used) |
| 26— Separator Plate (8 used) | 28— End Plate |

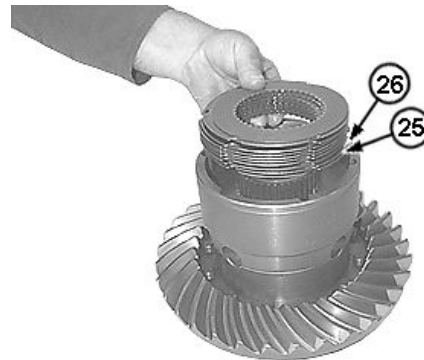

Differential Clutch Pack



End Plate

BJ21193,00000FD -19-30MAY17-10/67

TX1121016A—UN—28AUG12

TX1121017A—UN—28AUG12

14. Follow steps 15—18 to determine differential cover (29) to end plate (28) dimension (A).

Specification

Differential Cover to End	
Plate—Distance.....	8.0—8.2 mm
	0.315—0.323 in

- | | |
|------------------------------|---|
| 3— Differential Housing | 28— End Plate |
| 25— Separator Plate (8 used) | 29— Cover |
| 26— Friction Disk (8 used) | A—Differential Cover to End Plate Dimension |

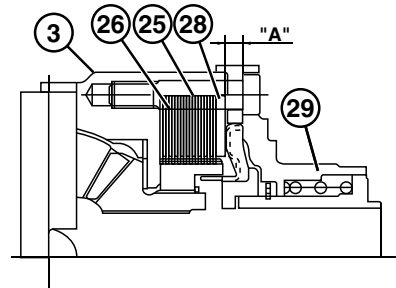

Differential Housing (cross-section)

Continued on next page

BJ21193,00000FD -19-30MAY17-11/67

TX1121018—UN—30OCT12

Axle Shaft, Bearings, and Reduction Gears

45. Apply multipurpose grease to adjusting rings (73) and insert into the ring groove of adjusting pins (74).

73— Adjusting Ring (5 used) 74— Adjusting Pin (5 used)

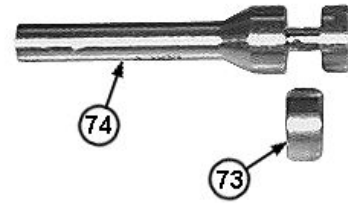

Adjusting Pin

BJ21193,00000FD -19-30MAY17-34/67

TX1121055A—UN—28AUG12

46. Install adjusting pins (74) flush with housing.

74— Adjusting Pin (5 used)

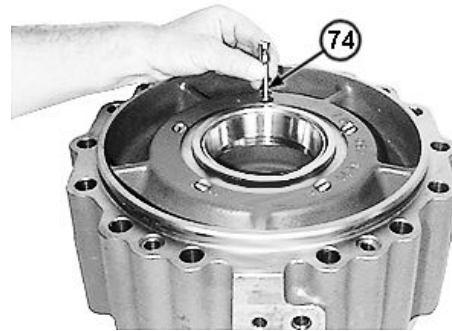

Adjusting Pins

BJ21193,00000FD -19-30MAY17-35/67

TX1121056A—UN—28AUG12

47. Install brake piston support plate (76).

76— Support Plate

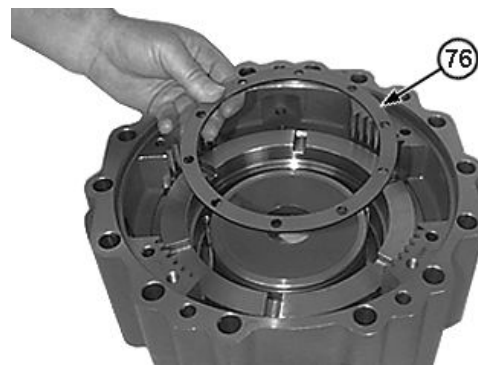

Support Plate

Continued on next page

BJ21193,00000FD -19-30MAY17-36/67

TX1121057A—UN—28AUG12

77. Planetary Assembly—Cylindrical Bearings

a. Install spring pin (2) in planetary carrier.

Specification

Planetary Carrier	
Spring Pin Installation	
(exposed)—Height.....	9.0—10.0 mm
	0.35—0.39 in

2— Spring Pin

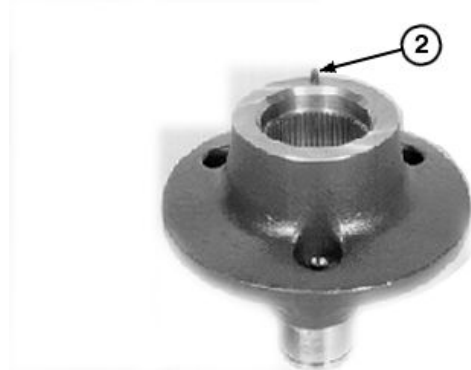

Planet Carrier Spring Pin

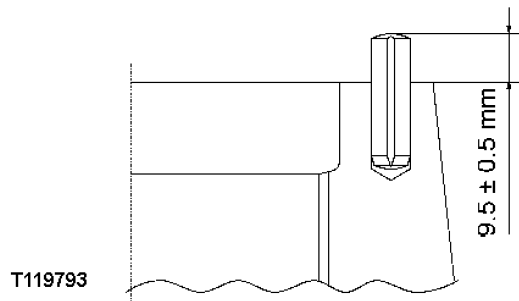

Planet Carrier Spring Pin Depth Dimension

BJ21193,00000FD -19-30MAY17-58/67

XJ1222260 —UN—31AUG16

T119793 —UN—01APR99

IMPORTANT: Damage to differential can occur. Dropping the planetary carrier assembly into housing can damage ring gear. Carefully install planetary carrier into housing.

b. Carefully install up planetary carrier (1) making sure spring pin (2) lines with a slot in the spanner nut (3).

- | | |
|----------------------|---------------------|
| 1— Planetary Carrier | 4— Bearing Assembly |
| 2— Spring Pin | 5— Axle Housing |
| 3— Spanner Nut | 6— Axle Shaft |

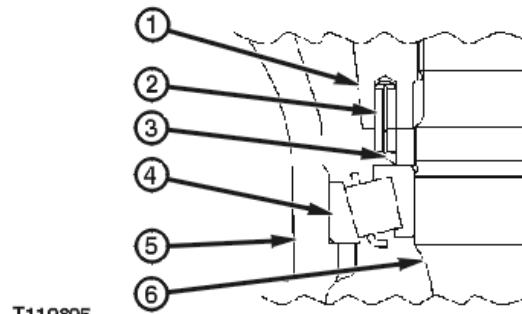

Planet Carrier Cross Section

Continued on next page

BJ21193,00000FD -19-30MAY17-59/67

T119805 —UN—30JAN99

NOTE: An etched match set number (40) at end of pinion shaft is used to identify pinion shaft with ring gear. Etched numbers on both components should match.

Stamped dimension I (38) on end of pinion shaft is used for calculating number of shims required (dimension Y). In addition to stamped dimension 1, an etched tolerance number (39) may be on end of some pinion shafts and should be added to (or subtracted from) stamped dimension 1 as necessary.

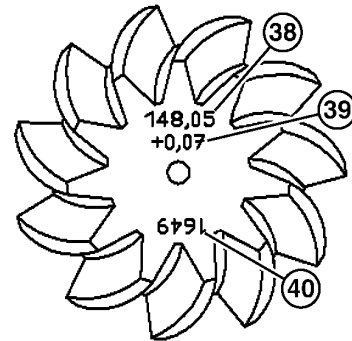

Pinion Gear Dimension I

21. Record stamped dimension I (38).

Example of Dimension I	
Dimension I Equals	148.05 mm 5.83 in.

38— Stamped Dimension I 40— Etched Match Set Number
39— Etched Tolerance Number

JD29379,0000217 -19-10SEP12-13/35

TX1120837 —UN—21AUG12

22. Using a depth gauge (41), measure and record complete inner bearing cone (29) and inner bearing cup (32) width (dimension II).

Example of Dimension II	
Dimension II Equals	33.50 mm 1.32 in.

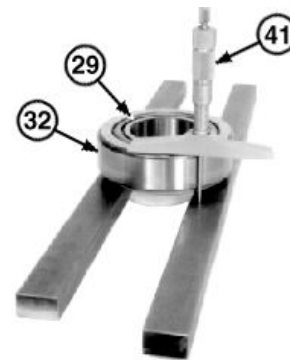

Bearing Width

23. Determine number of shims required behind pinion shaft inner bearing cup. See Examples A and B.

Example of Dimension Y Calculation Dimension I + Dimension II = Dimension Y	
Dimension I	148.05 mm 5.83 in.
Plus Dimension II	+ 33.50 mm 1.32 in.
Equals Dimension Y	= 181.55 mm 7.15 in.

29— Inner Bearing Cone 41— Depth Gauge
32— Inner Bearing Cup

Example of Shim Pack Calculation: Dimension X – Dimension Y = Shim Thickness	
Dimension X	182.75 mm 7.20 in.
Minus Dimension Y	—181.55 mm 7.15 in.
Equals Shim Thickness	=1.20 mm 0.05 in.

Continued on next page

JD29379,0000217 -19-10SEP12-14/35

TX1120838A —UN—21AUG12

1 Ideal Tooth Contact Pattern

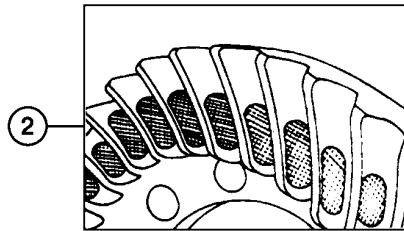
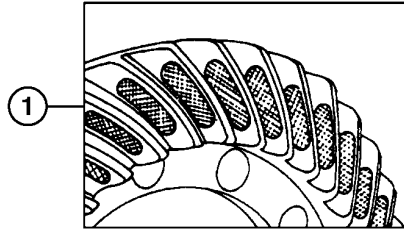

TX1120433 —UN—15AUG12

Ideal Tooth Contact Pattern

- 1— Coast Side (concave)
- 2— Drive Side (convex)

Does contact pattern match?

YES: Checks complete.

NO: Contact pattern at top of gear tooth indicates pinion shim is too thick. Go to Cone Point Decrease.

Contact pattern at bottom of gear tooth indicated pinion shim is too thin. Go to Cone Point Increase.

Continued on next page

DF89619,00B51EF -19-31AUG12-3/5

Group 0315 Controls Linkage

Transmission Control Lever (TCL) Remove and Install

1. Remove cap screws (1) and remove upper steering console cover (2).
2. Disconnect bucket position indicator (if equipped) (E75).

1— Cap Screw (5 used)
2— Upper Steering Console Cover

E75— Bucket Position Indicator (if equipped)

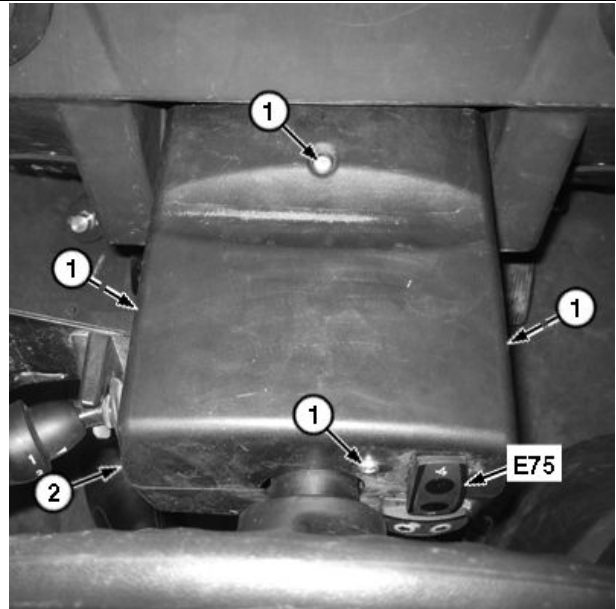

Upper Steering Console Cover

TX1113136A —UN—04JUN12

JD29379,000015C -19-05JUN12-1/2

3. Disconnect transmission control lever (TCL) connector (X48).
4. Remove cap screws (4) and TCL (5).
5. Inspect and replace parts as necessary.
6. Connect TCL connector.
7. Install TCL and cap screws (4).
8. Connect bucket position indicator (if equipped).
9. Install upper steering console cover and cap screws (1).

4— Cap Screw (2 used)
5— Transmission Control Lever (TCL)

X48— Transmission Control Lever (TCL) Connector

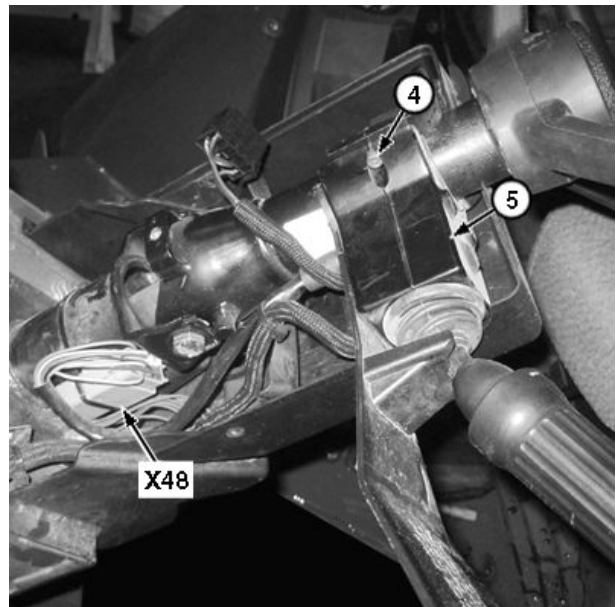

Transmission Control Lever (TCL)

TX1113390A —UN—04JUN12

JD29379,000015C -19-05JUN12-2/2

9. Support gear and drum assembly (24) in a press. Compress disc springs (22) using DFT1162 Clutch Pack Snap Ring Removal and Installation Tool (21). See DFT1162 Clutch Pack Snap Ring Removal and Installation Tool. (Group 9900.) Remove snap ring (23).
10. Remove flat washer (25) and disc springs.
11. Inspect disc springs for wear or damage. Replace if necessary.

- | | |
|---|----------------------------|
| 21— DFT1162 Clutch Pack Snap Ring Removal and Installation Tool | 24— Gear and Drum Assembly |
| 22— Disc Spring (5 or 7 used) | 25— Flat Washer |
| 23— Snap Ring | |



Snap Ring

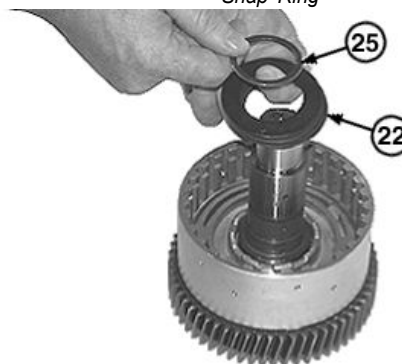

Flat Washer and Disc Springs

JD29379,00001FC -19-07JUL16-5/18

TX1118850A —UN—26JUL12

TX1118851A —UN—17AUG12

CAUTION: Prevent possible personal injury. Wear proper face and body protection when using compressed air.

IMPORTANT: Damage may occur if gear, drum, and shaft are disassembled. Gear, drum, and shaft are serviced as an assembly.

12. Remove piston (28) from shaft by applying compressed air into oil passage (29).

- | | |
|------------|-----------------|
| 28— Piston | 29— Oil Passage |
|------------|-----------------|

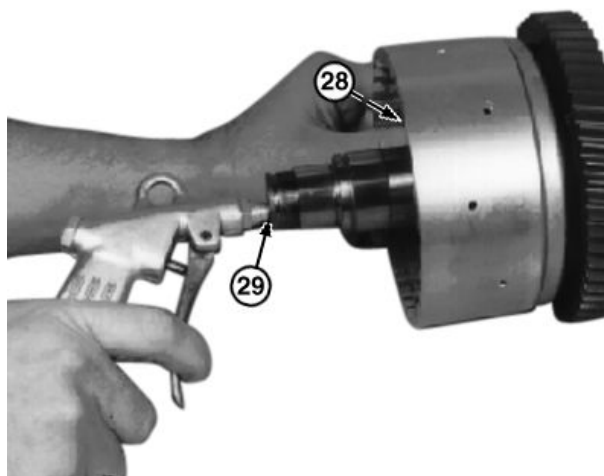

Piston

Continued on next page

JD29379,00001FC -19-07JUL16-6/18

TX1118857A —UN—26JUL12

- Remove bearing cone (8) and gear hub (9) as an assembly.

IMPORTANT: Internal transmission damage can occur if bearing cone and cup are replaced separately. If either bearing cone or cup requires replacement, replace both as a set. If not replacing bearing cones and cups, make sure to identify them or keep them together for correct assembly.

- Inspect bearing cone (8) and bearing cup (10). Replace if necessary.

8— Bearing Cone
9— Gear Hub

10— Bearing Cup

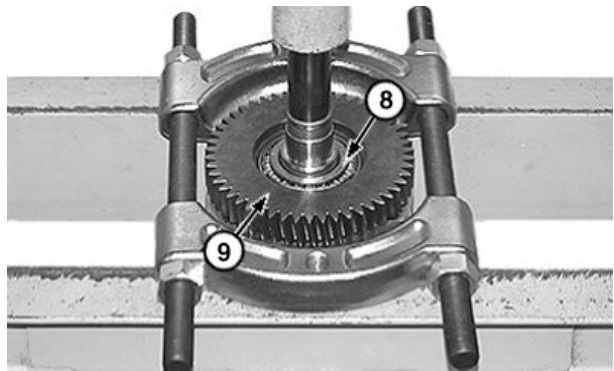

Bearing Removal



Gear Hub Bearing Cup

NM95233,000013D -19-14FEB13-4/22

TX1118999A —UN—26JUL12

TX1119000A —UN—26JUL12

IMPORTANT: Avoid transmission component damage. DO NOT reuse end plate snap ring when servicing clutch packs. Always replace with new snap ring.

NOTE: Low range forward and reverse clutch packs have 11 plates (16) and 11 disks (15). Third speed clutch pack has eight plates and eight disks.

- Remove end plate snap ring (12) and discard. Remove end plate (13).
- Remove plates (16) and disks (15).

12— End Plate Snap Ring
13— End Plate
14— Plate and Disk Assembly

15— Disk (8 used)
16— Plate (8 used)

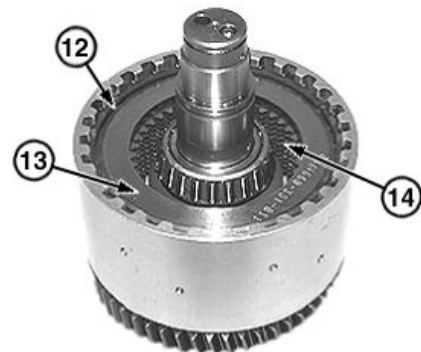

Clutch Pack Plate and Disk Assembly

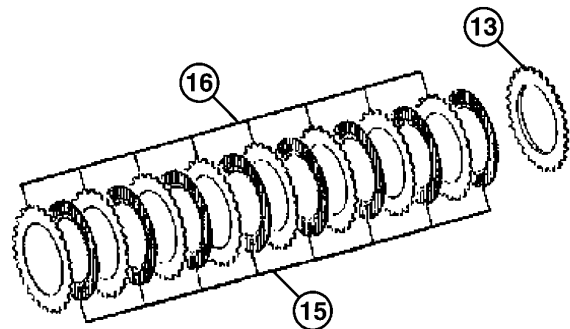

Third Speed Clutch (K3) Pack (exploded view)

Continued on next page

NM95233,000013D -19-14FEB13-5/22

TX1119001A —UN—26JUL12

TX1119002 —UN—26JUL12

MFWD Clutch Pack Disassemble and Assemble

1. Separate drum assembly (1) from gear hub and shaft assembly (2).

1— Drum Assembly

2— Gear Hub and Shaft Assembly

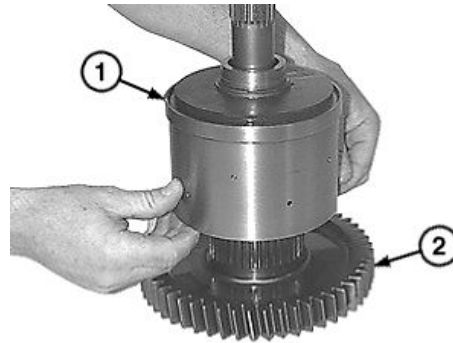

Drum and Gear Hub Assemblies

TX1119110A —UN—30JUL12

JD29379,00001FF -19-11SEP12-4/32

2. Using a driver (4), driver disk (5), and a press, apply specified force to clutch disks and plates.

Specification

End Plate—Force.....22 000 N
4946 lb.-force

IMPORTANT: Avoid transmission component damage. DO NOT reuse end plate snap ring (6) when servicing clutch pack. Always replace with new end plate snap ring.

3. Remove end plate snap ring (6) and discard.

4— Driver

5— Driver Disk

6— End Plate Snap Ring

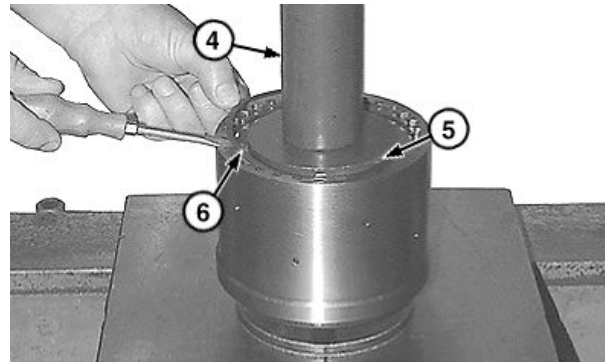

End Plate Snap Ring

TX1119111A —UN—30JUL12

Continued on next page

JD29379,00001FF -19-11SEP12-5/32

41. Using DFT1163 MFWD Snap Ring Removal and Installation Tool (12) and a press, apply pressure against spring pack (13). See [DFT1163 MFWD Snap Ring Removal and Installation Tool](#). (Group 9900.)

42. Remove snap ring (14).

- 12— DFT1163 MFWD Snap Ring Removal and Installation Tool
- 13— Spring Pack
- 14— Snap Ring

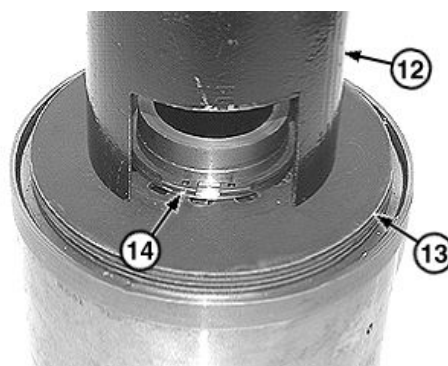

Spring Pack Snap Ring

JD29379,00001FF -19-11SEP12-27/32

TX1119114A —UN—30JUL12

43. Remove spacer (16) and spring pack (17).

- 16— Spacer
- 17— Spring Pack



Drum, Spacer, and Spring Pack

JD29379,00001FF -19-11SEP12-28/32

TX1119131A —UN—30JUL12

44. Support drum assembly (1) using an appropriate size driver (40) as shown.

45. Align and center disks, then install gear hub and shaft assembly (2). Make sure gear hub is fully inserted into drum.

- 1— Drum Assembly
- 2— Gear Hub and Shaft Assembly
- 40— Driver

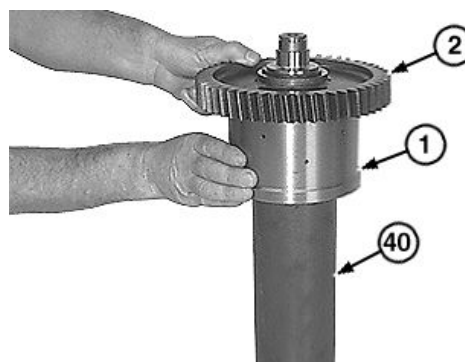

Gear Hub and Shaft Assembly

Continued on next page

JD29379,00001FF -19-11SEP12-29/32

TX1119132A —UN—30JUL12

TX1116768A—UN—28JUN12

Transmission Charge Pump Remove and Install

SPECIFICATIONS

Transmission Pump Socket Head Cap Screw Torque	115 N·m 85 lb.-ft.
--	-----------------------

OTHER MATERIAL

242 LOCTITE® Thread Lock and Sealer (medium strength)

1. Park and prepare machine for service. [See Park and Prepare for Service Safely.](#) (Group 0001.)
2. Drain transmission oil and remove transmission oil filter (1). [See Change Transmission Oil and Replace Filter.](#) (Operator's Manual.)
3. Remove hydraulic pump. [See Hydraulic Pump Remove and Install.](#) (Group 2160.)
4. Remove socket head cap screws (2) and transmission charge pump with shaft (3).
5. Repair or replace pump as necessary. [See Transmission Charge Pump Disassemble and Assemble.](#) (Group 0360.)

NOTE: Dowel pins can be installed into manifold plate to guide pump during installation.

6. Install transmission charge pump with shaft by inserting shaft into transmission drive shaft while aligning socket head cap screw holes.
7. Apply PM37418 Thread Lock And Sealer (medium strength) to threads of socket head cap screws.
8. Install socket head cap screws and tighten to specification.

LOCTITE is a trademark of Henkel Corporation

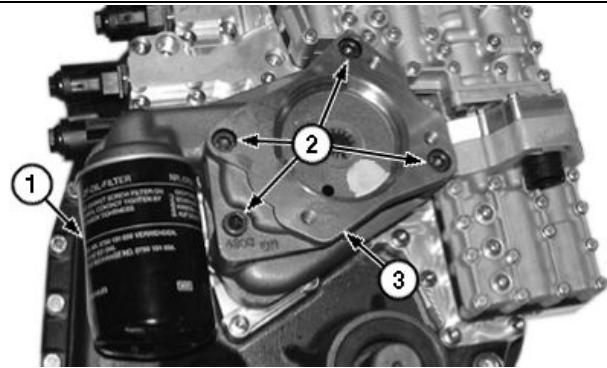

Transmission Charge Pump

- 1— Transmission Oil Filter
- 2— Socket Head Cap Screw (4 used)
- 3— Transmission Charge Pump with Shaft

Specification

Transmission Pump Socket Head Cap Screw—Torque.....	115 N·m 85 lb.-ft.
---	-----------------------

9. Install hydraulic pump. [See Hydraulic Pump Remove and Install.](#) (Group 2160.)
10. Install transmission oil filter and fill transmission. [See Change Transmission Oil and Replace Filter.](#) (Operator's Manual.)

JD29379,00001BB -19-10JUL12-1/1

Transmission Charge Pump Disassemble and Assemble

1. Remove shaft (1) from transmission charge pump (2).

1— Shaft

2— Transmission Charge Pump

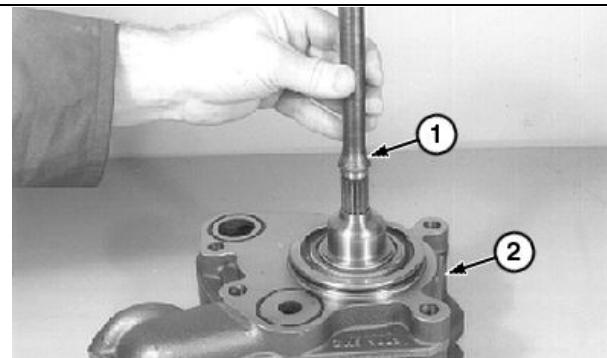

Transmission Charge Pump Shaft

TX1118173A—UN—18JUL12

Continued on next page

JD29379,00001BC -19-31JUL12-1/10

IMPORTANT: Thread lock and sealer can plug orifice (40). Apply only a very small amount of thread lock and sealer to threads of orifice set screw. Do not allow sealer to enter or block orifice.

22. Apply PM37418 Thread Lock and Sealer (medium strength) to threads of orifice (40) set screw.

23. Install orifice. Tighten to specification

Specification

Transmission Control	
Valve Orifice Set	
Screw—Torque.....	2.5 N·m
	22 lb.-in.

40— Orifice

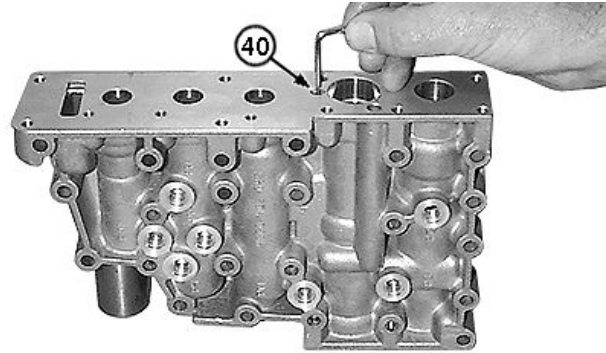

Orifice

JD29379,0000215 -19-05SEP12-12/22

TX1119254A—UN—31JUL12

24. Install modulation spool (38) and retaining ring (37).

25. Install pressure regulating valve spool (36), shims (35), and spring (34).

26. Shim Adjustment:

- a. For modulation valve, a 1 mm (0.039 in.) thick shim is equal to 42 kPa (0.42 bar) (6 psi). Measure shim thickness and select appropriate shim. See Modulation Valve Pressure Test. (Group 9020-25.)
- b. For pressure regulating valve, one shim is equal to 115 kPa (1.15 bar) (17 psi). Measure shim thickness and select appropriate shim. See Transmission System Pressure Test. (Group 9020-25.)

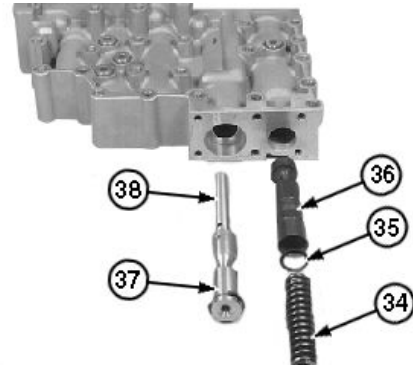

Pressure Regulating Valve Assembly

- | | |
|-------------------------------------|----------------------|
| 34— Spring | 37— Retaining Ring |
| 35— Shim (as required) | 38— Modulation Spool |
| 36— Pressure Regulating Valve Spool | |

Continued on next page

JD29379,0000215 -19-05SEP12-13/22

TX1119253A—UN—31JUL12

Transmission Solenoids Remove and Install

SPECIFICATIONS	
Transmission Differential Lock, Park Brake, and Mechanical Front Wheel Drive (MFWD) Solenoid Valve Torque	27 N·m 240 lb.-in.
Transmission Differential Lock, Park Brake, and Mechanical Front Wheel Drive (MFWD) Solenoid Coil Cap Torque	6 N·m 53 lb.-in.

1. Remove solenoid coil caps (1) and solenoid coils (2).
2. Remove solenoid valves (3).

- 1— Solenoid Coil Cap (3 used) 3— Solenoid Valve (3 used)
2— Solenoid Coil (3 used)

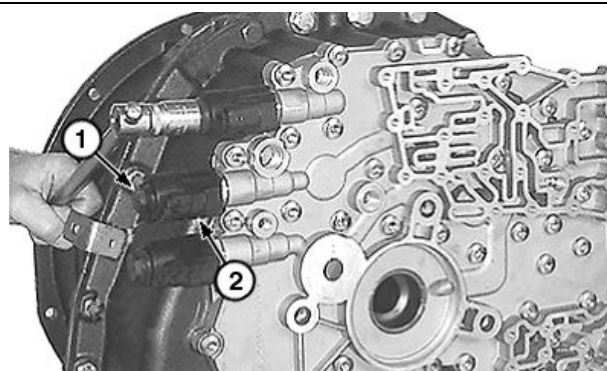

Solenoid Coils

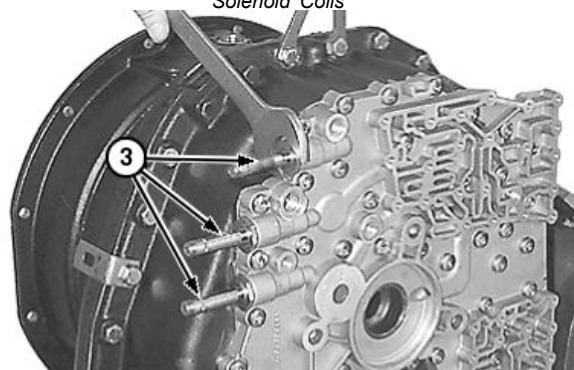

Solenoid Valves

JD29379.000020A -19-05SEP12-1/3

TX1119328A—UN—01AUG12

TX1119329A—UN—01AUG12

3. Inspect solenoid coil caps, solenoid coils, and solenoid valves. Replace if necessary.
4. Remove and discard O-rings (4—7).

- 1— Solenoid Coil Cap 5— O-Ring
2— Solenoid Coil 6— O-Ring
3— Solenoid Valve 7— O-Ring
4— O-Ring (2 used)

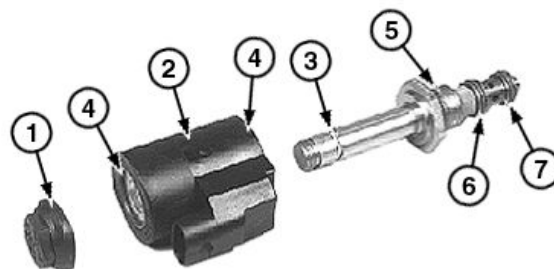

Solenoid (exploded view)

Continued on next page

JD29379.000020A -19-05SEP12-2/3

TX1119330A—UN—01AUG12

Removal and Installation

24. Disconnect heater hoses (21) and close all openings using caps and plugs.

21— Heater Hose (2 used)

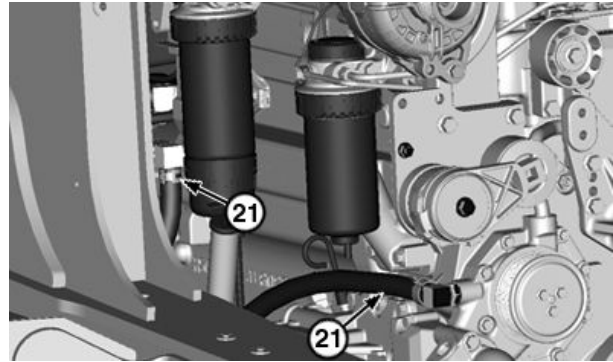

Heater Hoses

TX1117751A—UN—11JUL12

JD29379,00001DE -19-20JUL12-7/13

25. Remove nut (24) and cap screw (25).

26. Loosen adapter nut (26) and rotate transmission oil fill tube (27) away from engine.

27. Remove cap screws (28) and access plate (29) from flywheel housing (30).

24— Nut
25— Cap Screw
26— Adapter Nut
27— Transmission Oil Fill Tube

28— Cap Screw (2 used)
29— Access Plate
30— Flywheel Housing

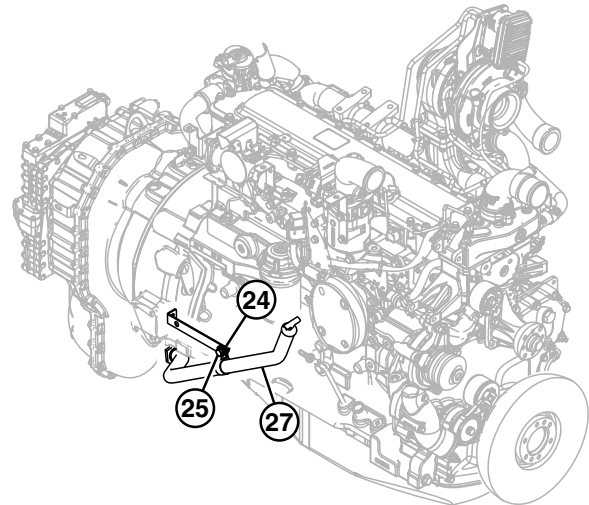

Transmission Oil Fill Tube Bracket

TX1117704—UN—11JUL12

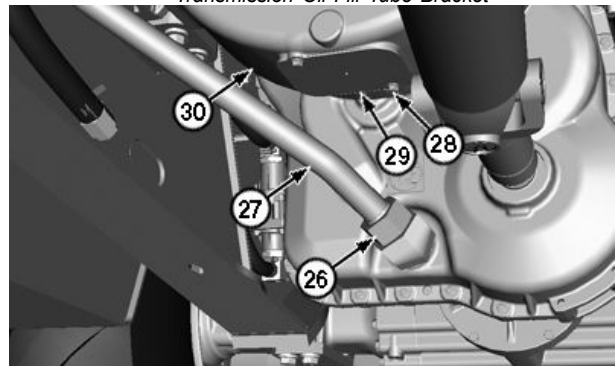

Transmission Oil Fill Tube and Flywheel Access Plate

TX1117701A—UN—11JUL12

Continued on next page

JD29379,00001DE -19-20JUL12-8/13

Removal and Installation

28. Install fuel filter and starting aid assembly aside (5) and cap screws (4).
29. Connect fuel filter-to-fuel lift pump hose (3).
30. Connect fuel filter heater (R26).

3— Fuel Filter-to-Fuel Lift
Pump Hose
4— Cap Screw (2 used)

5— Fuel Filter and Starting Aid
Assembly
R26— Fuel Filter Heater

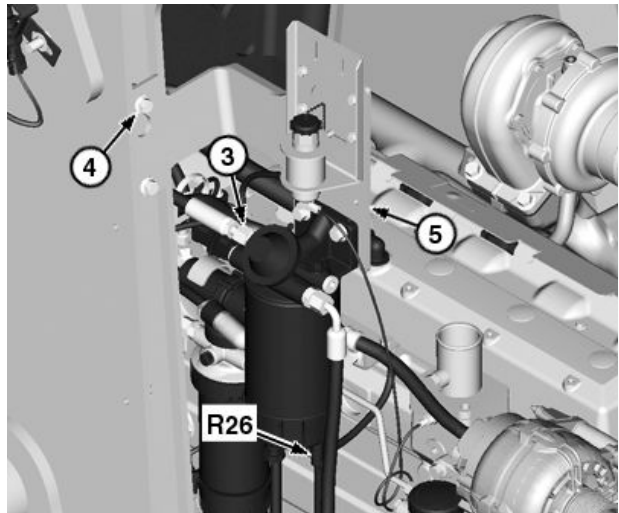

Fuel Filter and Starting Aid Assembly

JD29379,00001DF -19-20JUL12-12/13

TX111743A —UN—11JUL12

31. Machines Equipped with Air Conditioning Only:

- a. Install air conditioner compressor and cap screws (2).
 - b. Connect air conditioner compressor clutch solenoid (Y19) electrical connector (1).
32. Install muffler. See Muffler Remove and Install. (Group 0530.)
 33. Install cooling package. See Cooling Package Remove and Install. (Group 0510.)
 34. Install hood. See Hood and Engine Enclosure Disassemble and Assemble. (Group 1910.)
 35. Install grille. See Grille Remove and Install. (Group 1921.)
 36. Connect battery negative (–) ground cable or turn battery disconnect switch (if equipped) to the ON position. See Battery Disconnect—If Equipped. (Operator's Manual.)
 37. Disengage service lock and lower loader boom. See Loader Boom Service Lock. (Operator's Manual.)

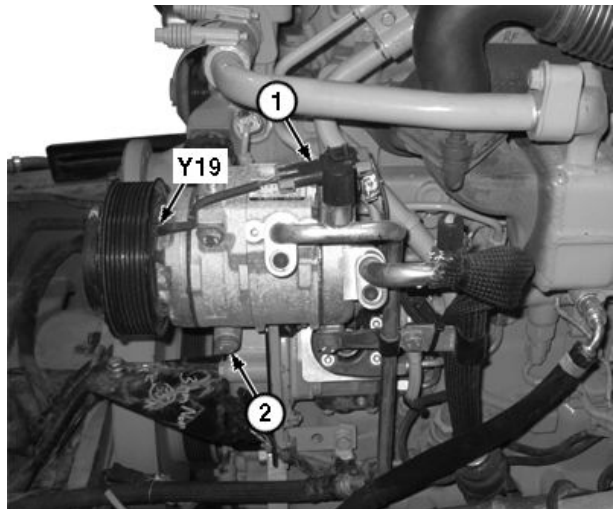

Air Conditioner Compressor (if equipped)

1— Electrical Connector
2— Cap Screw (3 used)

Y19— Air Conditioner
Compressor Clutch
Solenoid

JD29379,00001DF -19-20JUL12-13/13

TX1117668A —UN—11JUL12

8. Install serpentine belt.
9. Close hood.
10. Disengage loader boom service lock and lower loader to ground.

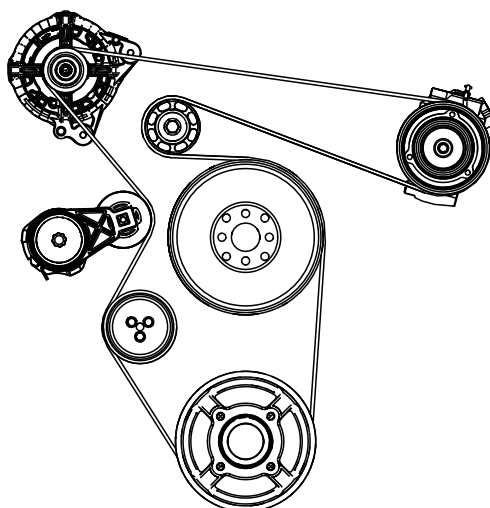

TX1115186—UN—05JUN12

JD29379,0000198 -19-11JUN12-2/2

Radiator Remove and Install

SPECIFICATIONS

Oil Cooler Assembly Weight (approximate)	40 kg 107 lb.
Radiator Weight (approximate)	26 kg 70 lb.

1. Raise loader boom and install boom service lock. See Loader Boom Service Lock. (Operator's Manual.)
2. Park and prepare machine for service. See Park and Prepare for Service Safely. (Group 0001.)
3. Remove cooling package. See Cooling Package Remove and Install. (Group 0510.)

NOTE: Cooling package can be secured back on frame after transmission oil cooler and hydraulic oil cooler hoses have been disconnected. This provides a stable platform for removing radiator.

4. Remove charge air cooler. See Charge Air Cooler Remove and Install. (Group 0520.)
5. Unhook latches (1), remove clip (2), and lockout bracket (3).

CAUTION: Prevent possible crushing injury from heavy component. Use appropriate lifting device.

6. Attach appropriate lifting device to oil cooler assembly (5).

Specification

Oil Cooler Assembly—Weight (approximate).....	40 kg 107 lb.
---	------------------

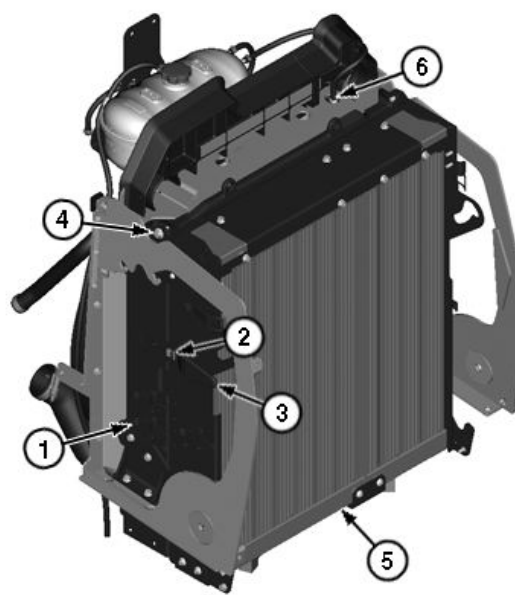

Oil Cooler Assembly

- | | |
|-------------------|-----------------------|
| 1—Latch (4 used) | 4—Cap Screw (2 used) |
| 2—Clip | 5—Oil Cooler Assembly |
| 3—Lockout Bracket | 6—Radiator Vent Hose |

7. Remove cap screws (4) and oil cooler assembly.
8. Disconnect radiator vent hose (6). Close all openings with caps and plugs.

TX1117274A—UN—06JUL12

Continued on next page

SL78608,0000912 -19-12JUL12-1/3

Group 0515 Speed Controls

Engine Speed Control Pedal Remove and Install

1. Park and prepare machine for service. See [Park and Prepare for Service Safely](#). (Group 0001.)
2. Disconnect battery negative (-) ground cable or turn battery disconnect switch (if equipped) to OFF position. See [Battery Disconnect—If Equipped](#). (Operator's Manual.)
3. Remove cap screws (2) and engine speed control pedal cover (1).

1— Engine Speed Control
Pedal Cover
2— Cap Screw (3 used)

B20— Engine Speed Control
Pedal

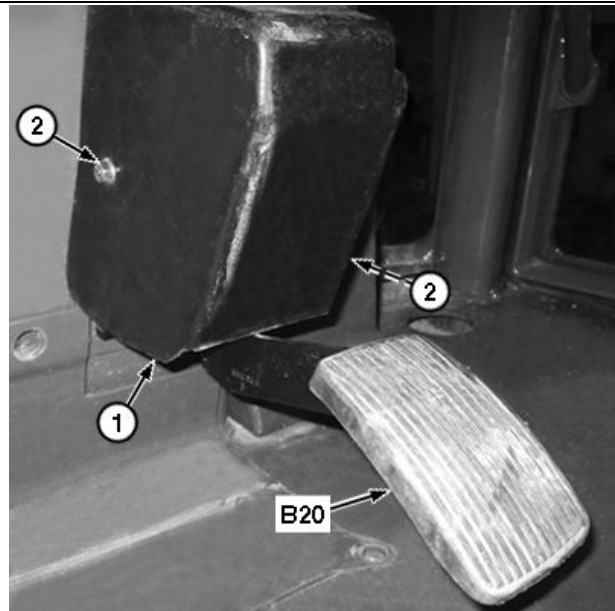

Engine Speed Control Pedal

TX1113178A —UN—04JUN12

JD29379,0000153 -19-06JUN12-1/2

4. Disconnect engine speed control pedal electrical connector (3).
5. Remove cap screws (4) and engine speed control pedal.
6. Repair or replace parts as necessary.
7. Install engine speed control pedal and cap screws (4).
8. Connect engine speed control pedal electrical connector.
9. Install engine speed control pedal cover and cap screws (2).
10. Turn battery disconnect switch (if equipped) to ON or connect battery ground cable.
11. Check operation of engine speed control pedal. See [Engine Speed Check](#). (Group 9010-25.)

3— Engine Speed Control
Pedal Electrical Connector
4— Cap Screw (3 used)

B20— Engine Speed Control
Pedal

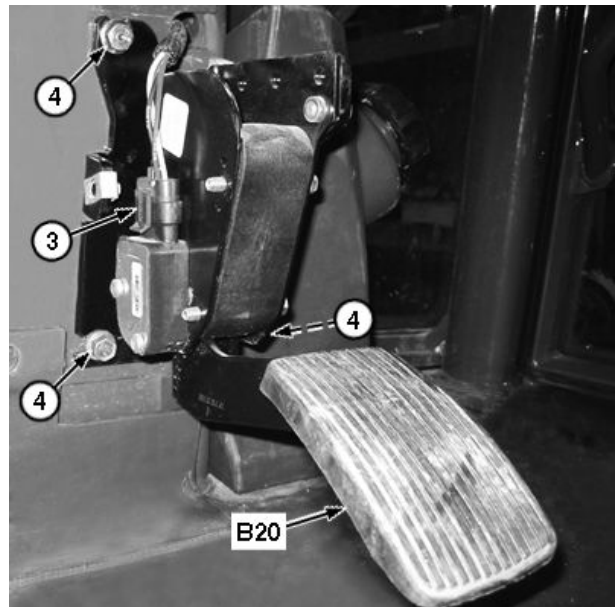

Engine Speed Control Pedal (cover removed)

TX1113179A —UN—04JUN12

JD29379,0000153 -19-06JUN12-2/2

Group 0651 Turbine, Gears, and Shaft

Torque Converter Remove and Install

SPECIFICATIONS

Cap Screw Torque	46 N·m 34 lb.-ft.
------------------	----------------------

OTHER MATERIAL

Loctite® Klean 'N Prime™ Primer
Loctite® 242® Threadlocker (medium strength)

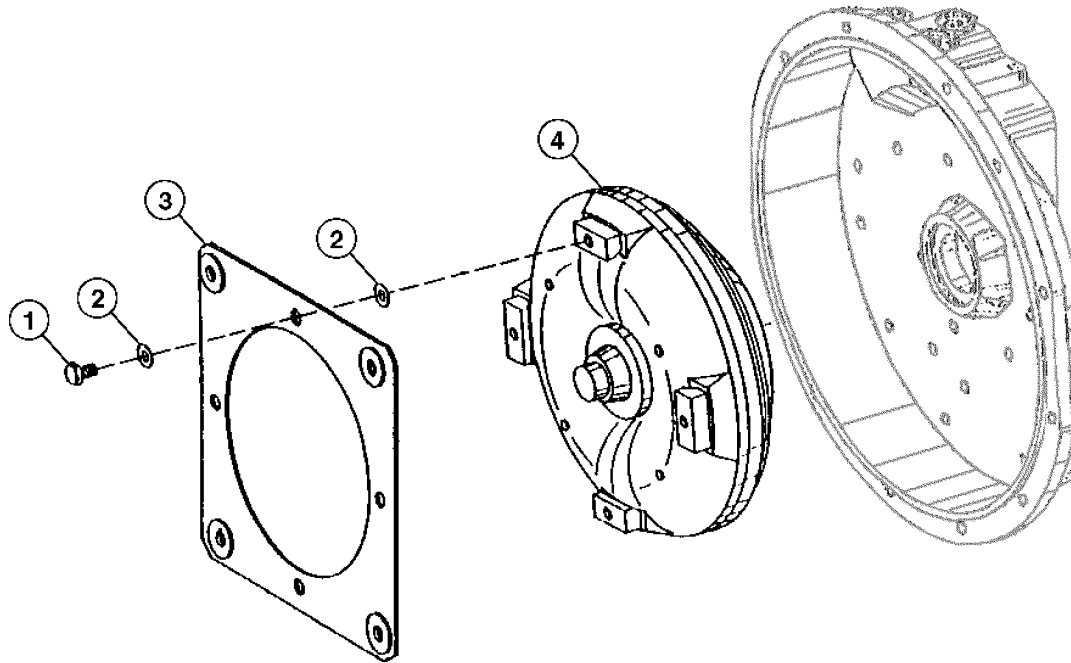

Torque Converter and Flexplate

- | | | |
|----------------------|----------------------|--------------------|
| 1—Cap Screw (4 used) | 2—Washer (8 used) | 4—Torque Converter |
| | 3—Flexplate (2 used) | |

NOTE: *Torque converter has no internal service parts. If replacement is necessary, install a new torque converter.*

- | | |
|--|--|
| <ol style="list-style-type: none"> 1. Remove transmission. <u>See Transmission Remove and Install.</u> (Group 0300.) 2. Remove cap screws (1), washers (2), and flexplate (3). 3. Slide torque converter (4) off transmission input shaft. 4. Inspect and replace as necessary. 5. Apply Loctite® Klean 'N Prime™ Primer and Loctite® 242® Threadlocker (medium strength) to threads of cap screws. | <ol style="list-style-type: none"> 6. Install flexplate, washers, and cap screws. Tighten to specification. 7. Install transmission. <u>See Transmission Remove and Install.</u> (Group 0300.) |
|--|--|

Specification

Cap Screw—Torque.....	46 N·m 34 lb.-ft.
-----------------------	----------------------

Loctite and its related brand marks are trademarks of Henkel Corporation

TX1116531—UN—25/JUN12

JD29379,00001B7 -19-19MAY15-1/1

CLICK HERE TO **DOWNLOAD** THE COMPLETE MANUAL

- Thank you very much for reading the preview of the manual.
- You can download the complete manual from: www.heydownloads.com by clicking the link below



- Please note: If there is no response to CLICKING the link, please download this PDF first and then click on it.

CLICK HERE TO **DOWNLOAD** THE COMPLETE MANUAL

25. Connect battery negative (–) ground cable or turn battery disconnect switch (if equipped) to the ON

position. See **Battery Disconnect—If Equipped.** (Operator's Manual.)

DF89619.00B51D4 -19-10JUL12-5/5

Steering Valve Disassemble and Assemble

SPECIFICATIONS	
Drive Spool Torque	0.11 N·m 1 lb·in
End Cap Mounting Cap Screw Initial Torque	17 N·m 150 lb·in
End Cap Mounting Cap Screw Final Torque	28–34 N·m 21–25 lb·ft
Elbow (1) Torque	50 N·m 37 lb·ft
Priority Valve Supply Check Valve (2) Torque	73 N·m 54 lb·ft
Elbow (3) Torque	24 N·m 212 lb·in
Adaptor (4) Torque	73 N·m 54 lb·ft
Elbow (5) Torque	73 N·m 54 lb·ft
Elbow (6) Torque	21 N·m 186 lb·in
Elbow (7) Torque	73 N·m 54 lb·ft
Stud (30) Torque (if equipped)	75 N·m 55 lb·ft

OTHER MATERIAL

TY24416 U.S. Multi-Purpose HD Lithium Complex Grease

1. Remove elbows (1, 3, and 5–7), priority valve supply check valve (2), adaptor (4), and stud (30) (if equipped) from steering valve (124).

- | | |
|--------------------------------------|------------------------|
| 1— Elbow | 6— Elbow |
| 2— Priority Valve Supply Check Valve | 7— Elbow |
| 3— Elbow | 30— Stud (if equipped) |
| 4— Adaptor | 124— Steering Valve |
| 5— Elbow | |

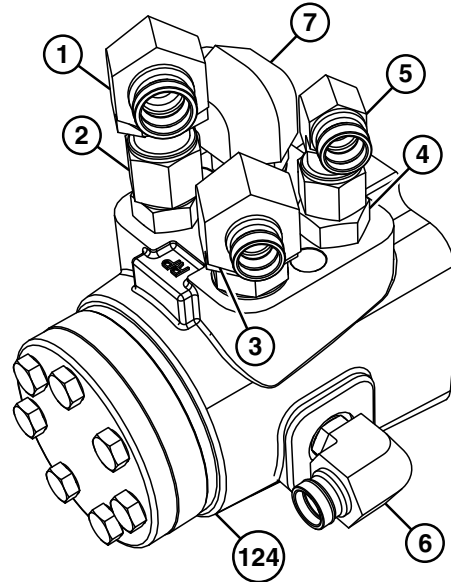

Steering Valve Fittings (S.N. —329327)

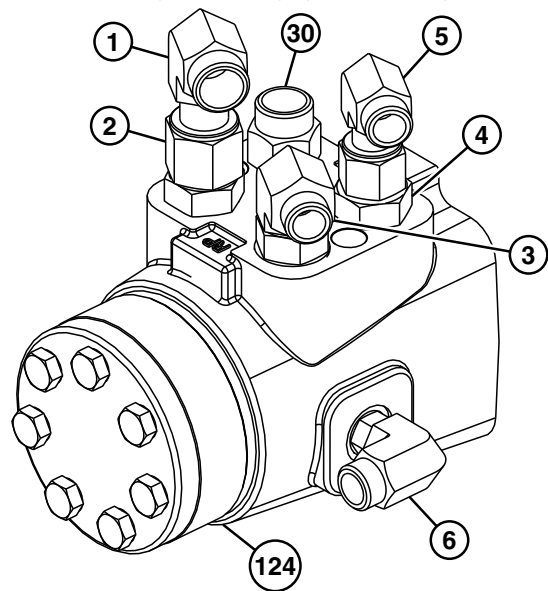

Steering Valve Fittings (S.N. 329328—)

TX1118488 —UN—20JUL12

TX1257616 —UN—01JUN18

Continued on next page

BJ21193.000015B -19-12JUN18-1/9

Mechanical Front Wheel Drive (MFWD) Axle Steering Cylinder Remove and Install

OTHER MATERIAL

U.S. NEVER-SEEZ® Anti-Seize Lubricant

1. Park and prepare machine for service. See Park and Prepare for Service Safely. (Group 0001.)
2. Raise loader and install boom lock bar. See Loader Boom Service Lock. (Operator's Manual.)
3. Release hydraulic system pressure. See Hydraulic Circuit Pressure Release. (Group 9025-25.)
4. Remove counterweights, if equipped. See Counterweight Remove and Install. (Group 1749.)
5. Remove tie rods. See Tie Rod Remove and Install. (Group 0230.)
6. Install identification tag and disconnect steering hoses (1). Close all openings using caps and plugs.
7. Remove cap screws (2) and steering cylinder (3).
8. Repair or replace as necessary. See Mechanical Front Wheel Drive (MFWD) Axle Steering Cylinder Disassemble and Assemble. (Group 0960.)

NEVER-SEEZ is a trademark of Emhart Chemical Group

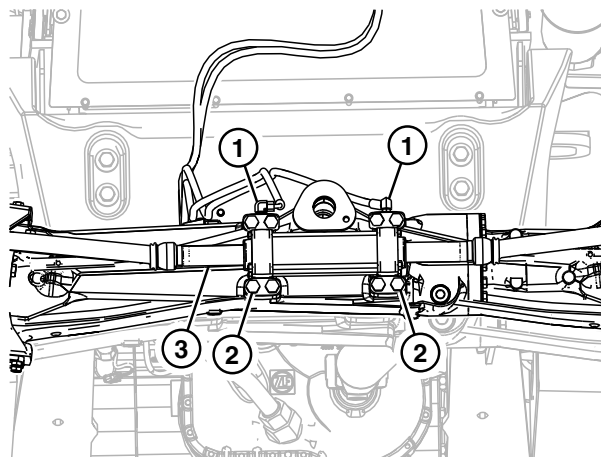

Mechanical Front Wheel Drive (MFWD) Axle Steering Cylinder

- 1— Steering Hose (2 used) 3— Steering Cylinder
 2— Cap Screw (8 used)

TX1120066 —UN—15AUG12

SL78608,000060D -19-27AUG12-1/2

9. Apply TY24811 Anti-Seize Lubricant to the anti-seize locations (4) before installing cap screws.
10. Install steering cylinder and cap screws.
11. Connect steering hoses.
12. Install tie rods. See Tie Rod Remove and Install. (Group 0230.)
13. Install counterweights, if removed. See Counterweight Remove and Install. (Group 1749.)
14. Remove boom lock bar and lower loader. See Loader Boom Service Lock. (Operator's Manual.)

- 4— Anti-Seize Location (2 used)

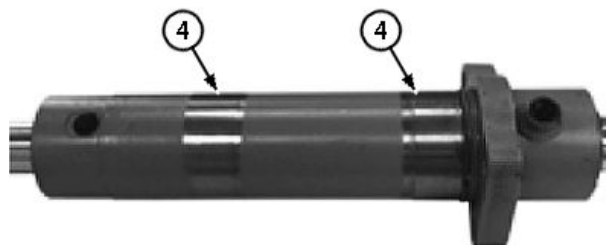

Anti-Seize Location

TX1120496A —UN—15AUG12

SL78608,000060D -19-27AUG12-2/2

Hydraulic System

16. Secure brake valve and remove cap screws (13).
17. Repair or replace valve as necessary.
18. Install brake valve and cap screws (13).
19. Connect lines to appropriate valve port using color coding guide.
20. Connect brake pressure sensor 1, brake pressure sensor 2, and brake light pressure switch 1 electrical connectors.
21. Close the steering and brake valve access door and install cap screws (9).
22. Install floor access panel and cap screws (7).
23. Install engine speed control pedal. [See Engine Speed Control Pedal Remove and Install.](#) (Group 0515.)
24. Install brake pedals, pivot pin, and snap ring.
25. Install pins and cotter pins.
26. Install front console. [See Front Console Remove and Install.](#) (Group 1810.)
27. Install front floor mat.
28. Fill hydraulic oil reservoir or remove vacuum from hydraulic oil reservoir. [See Change Hydraulic Reservoir Oil.](#) (Operator's Manual.)
29. Connect battery negative (-) ground cable or turn battery disconnect switch (if equipped) to the ON position. [See Battery Disconnect—If Equipped.](#) (Operator's Manual.)

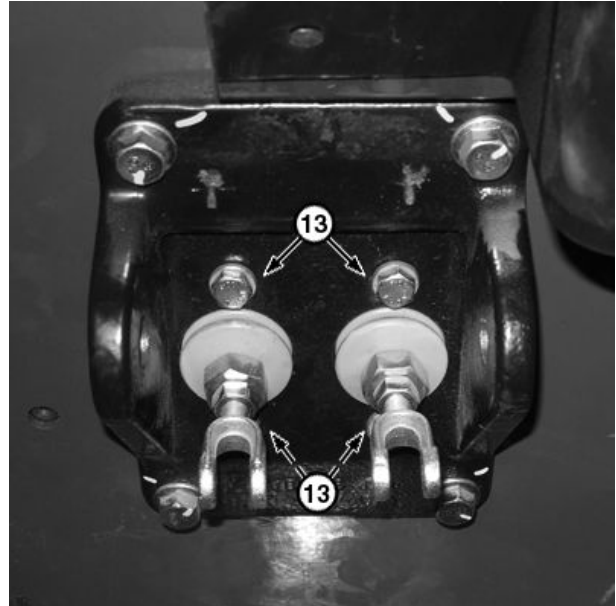

Brake Valve Cap Screws

13— Cap Screw (4 used)

30. Bleed brake system. [See Service Brake Bleeding Procedure.](#) (Group 9020-20.)

DF89619,00B520B -19-06JUL12-5/5

TX1116239A —UN—09JUL12

Brake Pedal Adjustment

For brake pedal adjustment, [see Service Brake Pedal Adjustment.](#) (Group 9020-20.)

JD29379,0000167 -19-05MAY12-1/1

Frame Installation

6. Install fastener with installation tool in hexagon hole. Make sure flange (C) is flat against mounting surface.

IMPORTANT: NEVER turn or tighten JDG894 Installation Tool socket head screw. Damage to threads of fastener can occur.

7. While holding socket head screw (A) stationary, tighten large (1-1/16 in.) nut (B) to specifications using a crowsfoot wrench.

Specification

RIVNUT® (KREMNUIT)

Fastener—Torque..... 68—74 N·m (50—55 lb-ft)

8. Loosen large nut to remove tool.

A—Socket Head Screw
B—Nut

C—Flange

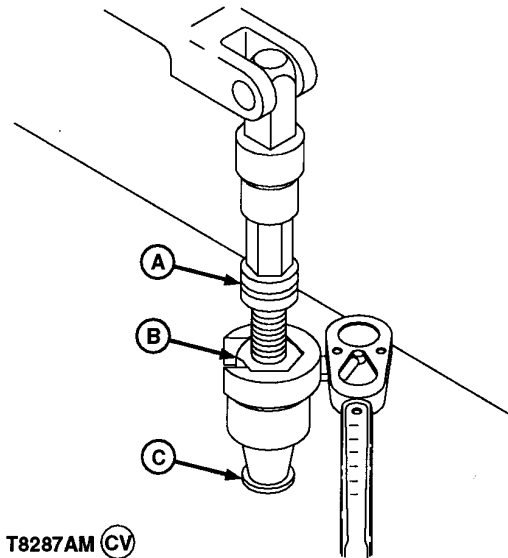

T8287AM —UN—17OCT94

RIVNUT is a registered trademark of The BF Goodrich Co.

JD29379.0000164 -19-14FEB13-4/4

Removal and Installation

22. Disconnect cab power lead (35) from starter motor (M1).

35— Cab Power Lead

M1—Starter Motor

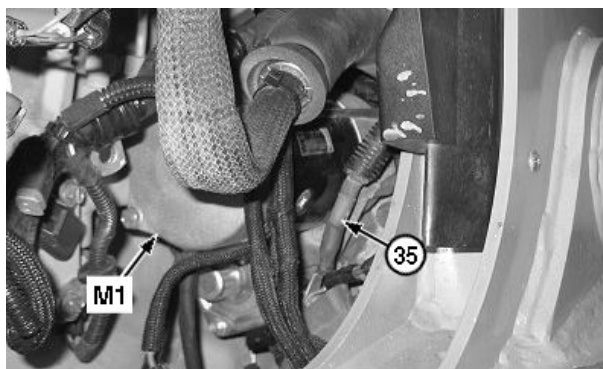

Cab Power Lead

TX1117529A —UN—11JUL12

SL78608,0000921 -19-14SEP12-9/12

23. Disconnect boom lock hook (38) from rod (39).

38— Boom Lock Hook

39— Rod

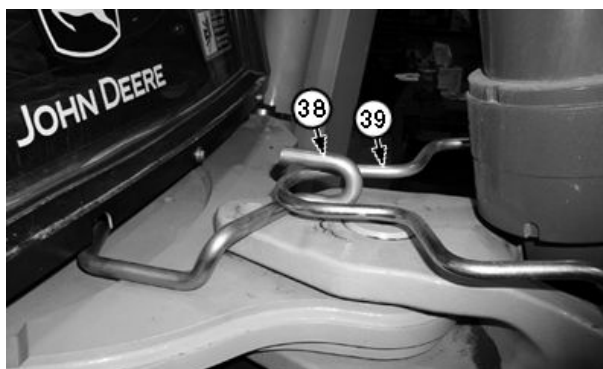

Boom Lock

TX1117530A —UN—10JUL12

SL78608,0000921 -19-14SEP12-10/12

CAUTION: Prevent possible crushing injury from heavy component. Use appropriate lifting device.

24. Install DFT1101 Lift Bracket (40) using chains and lifting straps. See DFT1101 Cab and ROPS Lift Bracket. (Group 9900.)

- a. Attach front lifting straps to exterior hand rails (41).
- b. Open the rear side windows and attach rear lifting straps to upper window latch loop (42).
- c. Remove slack from chains and lifting straps.

Specification

Cab—Weight..... 746 kg
1645 lb.

40— DFT1101 Lift Bracket

42— Lifting Location

41— Lifting Location



DFT1101 Lift Bracket

TX1117534A —UN—10JUL12

Continued on next page

SL78608,0000921 -19-14SEP12-11/12

Fixed Window Remove and Install

NOTE: Use this procedure to replace cab front, rear side, and lower door windowpanes.

Use Quick Cure Primerless Autoglass Windshield Sealant or equivalent to hold windowpanes in place. DO NOT use any other type of adhesive other than a urethane. It is also recommended that an auto glass dealer install windowpanes.

IMPORTANT: Windowpanes must have an ultra-violet barrier around edge of glass since ultra-violet rays will deteriorate adhesive. Windowpanes ordered through John Deere Parts have ultra-violet barrier. If windowpane is purchased through a glass dealer, dealer must put an ultra-violet barrier on glass. DO NOT apply paint to border of glass.

If an auto glass dealer is not installing windowpanes, use the following procedure:

1. Purchase urethane adhesive from your local auto glass dealer.
2. Park and prepare machine for service. See Park and Prepare for Service Safely. (Group 0001.)
3. If window frame is removable, remove frame from cab.
4. Scrape broken glass off existing adhesive. DO NOT remove adhesive from window frame or cab.
5. Trim existing adhesive so it has a smooth surface.
6. Apply a 12.5 mm (1/2 in.) bead of adhesive on top of existing adhesive.
7. Place a new windowpane into position. Use light hand pressure to force windowpane down around edges until even with metal frame. DO NOT over press adhesive.
8. If windowpane is installed directly on cab, use tape to hold it in place while adhesive cures.
9. Allow adhesive to cure for 24 hours before operating machine.

SL78608,0000620 -19-10JUL12-1/1

Seat and Seat Belt

8. Mark position of seat position sensor (B9).

NOTE: Lever (37) and seat position sensor are keyed.

Lever and base (35) removal is not necessary to remove seat position sensor.

9. Remove socket head screws (34), and seat position sensor.

NOTE: Lever (37) is attached (inserted) into base (35) using a friction fit only. Lever can be separated by lightly pulling lever and base apart by hand and out of the center diameter of swivel seat assembly.

10. If needed, remove remaining components (35, 37, 38) from swivel seat assembly (36) as shown.

34— Socket Head Screw (2 used)
35— Base (guide)
36— Swivel Seat Assembly

37— Lever
38— Screw (with locking nut)
B9— Seat Position Sensor

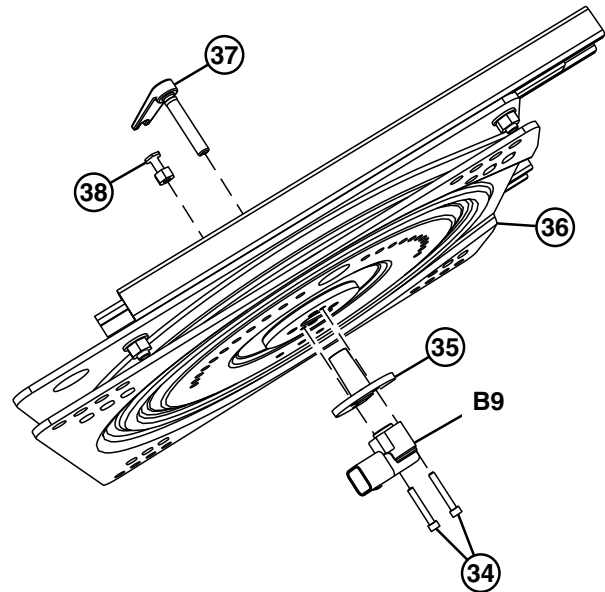

TX1141946—UN—13AUG13

SL78608,00006AB -19-22AUG13-4/8

11. Remove plastic fasteners (15) and boot (16).

15— Plastic Fastener (27 used) 16— Boot

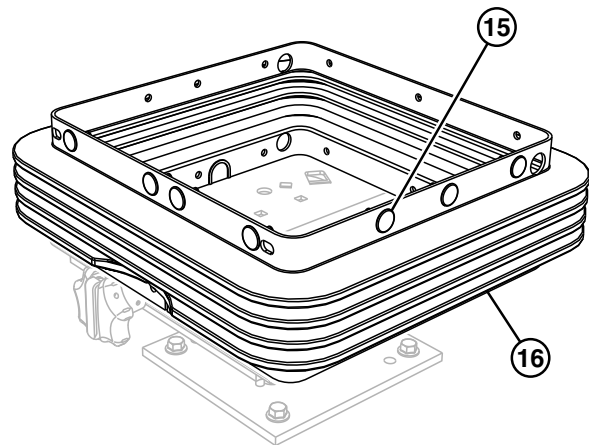

Boot Removal

TX1121136—UN—23AUG12

Continued on next page

SL78608,00006AB -19-22AUG13-5/8

R134a Refrigerant Cautions and Proper Handling

⚠ CAUTION: DO NOT allow liquid refrigerant to contact eyes or skin. Liquid refrigerant will freeze eyes or skin on contact. Wear goggles, gloves and protective clothing.

If liquid refrigerant contacts eyes or skin, DO NOT rub area. Splash large amounts of COOL water on affected area. Go to a physician or hospital immediately for treatment.

DO NOT allow refrigerant to contact open flames or very hot surfaces such as electric welding arc, electric heating element and lighted smoking materials.

DO NOT heat refrigerant over 52 °C (125 °F) in a closed container. Heated refrigerant will develop high pressure, which can burst the container.

Keep refrigerant containers away from heat sources. Store refrigerant in a cool place.

DO NOT handle damp refrigerant container with your bare hands. Skin may freeze to container. Wear gloves.

If skin freezes to container, pour COOL water over container to free the skin. Go to a physician or hospital immediately for treatment.

IMPORTANT: To meet government standards relating to the use of refrigerants, R134a is used in the air conditioning system. Because it does not contain chlorine, R134a is not detrimental to the ozone in the atmosphere. However, it is illegal to discharge any refrigerant into the atmosphere. It must be recovered using the appropriate recovery stations.

Use correct refrigerant recovery/recycling and charging stations. Never mix refrigerants, hoses, fittings, components or refrigerant oils.

IMPORTANT: Use only John Deere approved R134a refrigerant products. Mixing of products not compatible will cause system damage and contaminate recovery/recycling and charging station equipment. Care must be taken to identify and use equipment, refrigerant oil and refrigerant designed only for R134a refrigerant systems. Refrigerant should be tested for type and purity before recovery, recycling or charging of system. JT02167A Prism Pro Refrigerant Identification Instrument should be used before any testing or repair to system is performed.

SL78608,0000935 -19-01APR15-1/2

Prism Pro Refrigerant Identification Instrument.. JT02167A

To safely identify type and check purity of refrigerant prior to recovery, recycling and recharging of A/C systems.

SL78608,0000935 -19-01APR15-2/2

R134a Compressor Oil Removal

1. Park and prepare machine for service. See Park and Prepare for Service Safely. (Group 0001.)
2. Remove compressor from machine. See Compressor Remove and Install. (Group 1830.)
3. Drain oil into graduated container while rotating compressor shaft.
4. Record measured oil and discard oil properly.
5. Install new oil. See R134a Component Oil Charge. (Group 1830.)
6. Install compressor. See Compressor Remove and Install. (Group 1830.)

SL78608,0000936 -19-04JUN12-1/1

9. Disconnect and tag refrigerant hoses (10). Close all openings using caps and plugs.
10. Remove cap screw (11) and expansion valve (12).
11. Repair or replace as necessary.
12. Install expansion valve (12) and cap screw (11). Tighten cap screw (11) to specification.

Specification

Cap Screw—Torque..... 5.2—6.2 N·m
46—55 lb·in.

13. Install refrigerant hoses.
14. Install lower console cover and stabilizer cover.
15. Install cap screws (7 and 6).
16. Install air filter grille to lower console cover.
17. Install floor mats.
18. Install new receiver-dryer. [See Receiver-Dryer Remove and Install.](#) (Group 1830.)
19. Evacuate and charge air conditioning system. [See Evacuate R134a System](#) and [see Charge R134a System.](#) (Group 1830.)

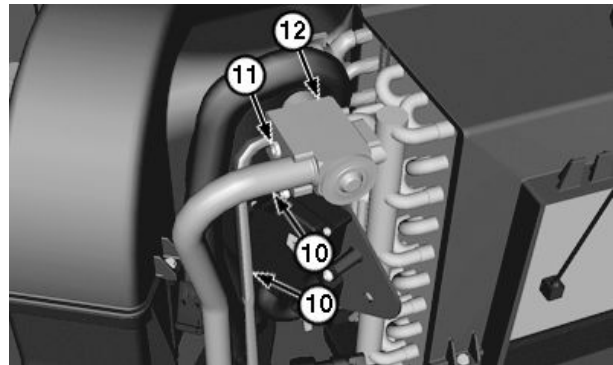

Expansion Valve

10— Refrigerant Hose (2 used) 12— Expansion Valve
11— Cap Screw

20. Connect negative (-) battery cable or turn battery disconnect switch to ON position. [See Battery Disconnect—If Equipped.](#) (Operator's Manual.)

SK44377,00002B3 -19-01DEC14-2/2

TX1121487A—UN—28AUG12

Air Conditioner Freeze Control Switch Remove and Install

1. Park and prepare machine for service. [See Park and Prepare for Service Safely.](#) (Group 0001.)
2. Remove cap screws (1), washers (2), and cap screws (3).
3. Remove stabilizer linkage access cover (4).

1— Cap Screw (3 used)
2— Washer (3 used)

3— Cap Screw (2 used)
4— Stabilizer Linkage Access Cover

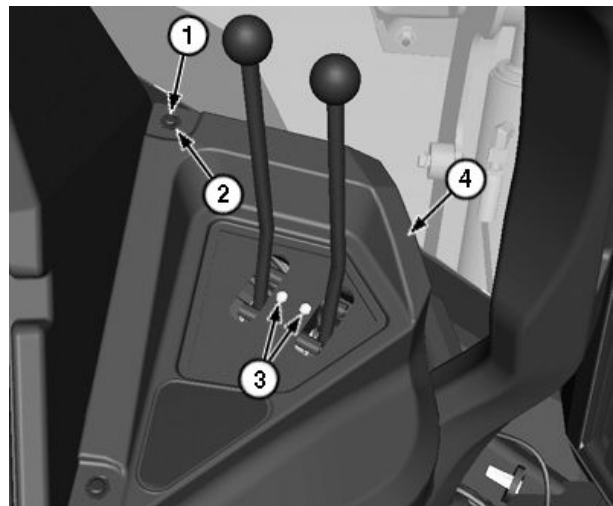

Stabilizer Linkage Access Cover

Continued on next page

SL78608,0000638 -19-11SEP12-1/4

TX1115502A—UN—13JUN12

Battery Box Remove and Install

SPECIFICATIONS	
Battery Weight (approximate)	29 kg 64 lb.
Battery Box Weight (approximate)	61 kg 135 lb.

1. Park machine and prepare for service. See Park and Prepare for Service Safely. (Group 0001.)
2. Raise loader boom and install service lock. See Loader Boom Service Lock. (Operator's Manual.)
3. Remove cap screws (1) and washers (2).
4. Remove tool box (3).

1— Cap Screw (3 used) 3— Tool Box
2— Washer (3 used)

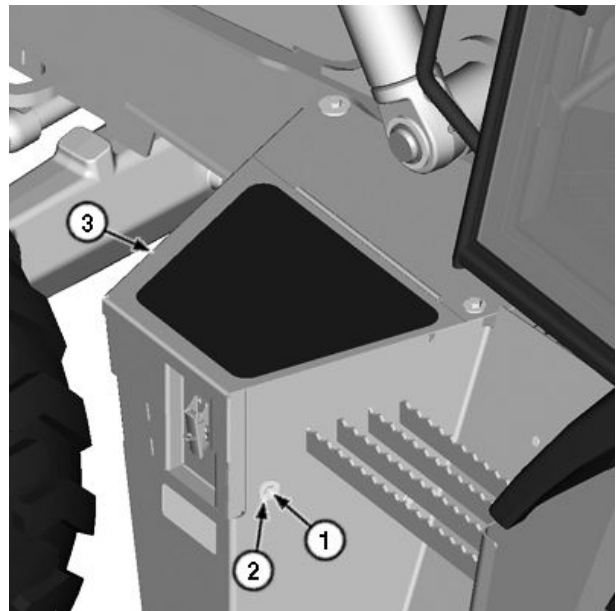

Tool Box

TX1113397A —UN—05JUN12

JD29379.000015E -19-06JUN12-1/3

5. Disconnect negative (-) battery cable (4) first, then disconnect positive (+) battery cable (5).
6. Remove flange nut (6).
7. Remove nuts (7) and washers (8).
8. Remove Brackets (9).

⚠ CAUTION: Prevent possible crushing injury from heavy component. Use appropriate lifting device.

9. Remove battery 1 and battery 2 (G1 and G2) using appropriate lifting device.

Specification

Battery—Weight
(approximate)..... 29 kg
64 lb.

4— Negative (-) Battery Cable 8— Washer (4 used)
5— Positive (+) Battery Cable 9— Bracket (2 used)
6— Flange Nut G1—Battery 1
7— Nut (4 used) G2—Battery 2

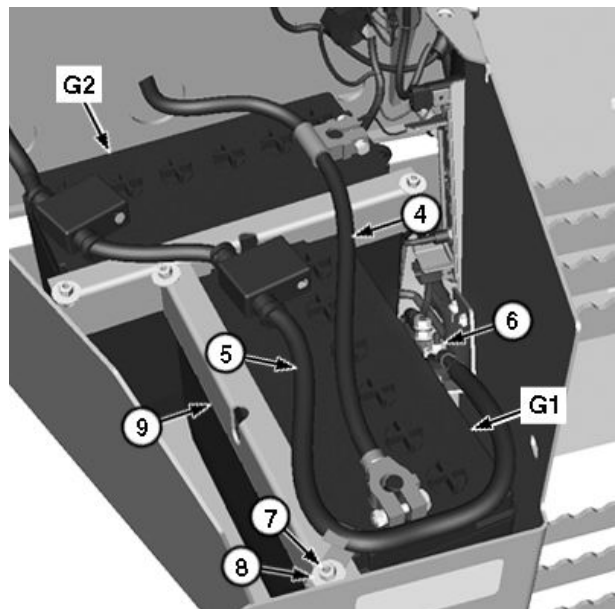

Batteries

TX1113414A —UN—04JUN12

Continued on next page

JD29379.000015E -19-06JUN12-2/3

Section 21 Main Hydraulic System

Contents

	Page
Group 2160—Hydraulic System	
General Oil Cleanup Procedure	21-2160-1
Apply Vacuum to Hydraulic Oil Reservoir	21-2160-2
Hydraulic Pump Remove and Install	21-2160-2
Hydraulic Pump Control Disassemble and Assemble	21-2160-5
Hydraulic Pump Disassemble and Assemble	21-2160-6
Hydraulic Reservoir Remove and Install	21-2160-7
Load Sense Generation Valve Remove and Install	21-2160-10
Hydraulic Filter Assembly Remove and Install	21-2160-11

Hydraulic System

12. Attach hoist and lifting straps (16) to pump suction elbow (17) and lower mounting brackets (18).

13. Raise hoist until lifting straps show tension.

Specification

Hydraulic Oil Reservoir—Weight (approximate).....	59 kg 130 lb
---	-----------------

14. Remove cap screws (19).

15. Raise and move reservoir slightly towards rear of machine to provide access to rear and bottom of reservoir.

16. Tag and disconnect hoses (14 and 15). Close all openings using caps and plugs.

17. Remove hydraulic oil reservoir from machine.

18. Repair or replace hydraulic oil reservoir as necessary.

16— Lifting Strap (3 used)
17— Pump Suction Elbow

18— Lower Mounting Bracket (2 used)
19— Cap Screw (3 used)

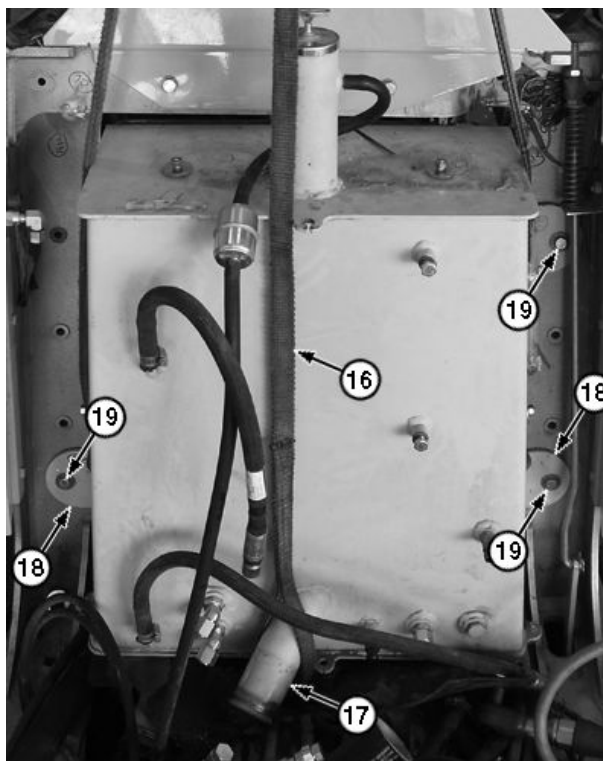

Hydraulic Oil Reservoir Lifting Points

TX1116172A—UN—20JUN12

DF89619,00B520A -19-05DEC16-4/5

19. When installing the sight glass (25), tighten cap screws (26) to specification.

Specification

Cap Screw—Torque.....	4 N·m 35 lb·in
-----------------------	-------------------

20. Move hydraulic oil reservoir above seated position and connect hoses (7, 14, and 15).

21. Move reservoir into standard seated position and install cap screws (19).

22. Remove lifting straps and hoist.

23. Install remaining hoses.

24. Install electrical connector to hydraulic oil temperature sensor.

25. Install isolators, plastic fasteners, and nuts.

26. Install brake accumulator assembly and cap screws (3).

27. Install hood cowling and cap screws (1).

28. Install operator's station. See Operator's Station Remove and Install. (Group 1800.)



Hydraulic Oil Reservoir Sight Glass

25— Sight Glass

26— Cap Screw (2 used)

XJ1229432A—UN—29NOV16

29. Fill hydraulic oil reservoir. See Change Hydraulic Reservoir Oil. (Operator's Manual.)

30. Connect battery negative (—) ground cable or turn battery disconnect switch (if equipped) to the ON position. See Battery Disconnect—If Equipped. (Operator's Manual.)

DF89619,00B520A -19-05DEC16-5/5

Loader Bucket Remove and Install

SPECIFICATIONS

Loader Bucket Weight (approximate)	875 kg 1930 lb.
---------------------------------------	--------------------

CAUTION: Prevent possible injury from falling linkage. Bucket cylinder and links will fall when pins are removed. Support or block linkage before removing pins.

1. Park and prepare machine for service. See Park and Prepare for Service Safely. (Group 0001.)
2. Lower all equipment to ground and stop engine.
3. Release pressure in hydraulic system. See Hydraulic Circuit Pressure Release. (Group 9025.)
4. Attach bucket cylinder (1) to an appropriate lifting device. Carefully rest the cylinder against the machine so as not to damage hose fitting at top of cylinder.
5. Remove snap rings (2), washers (3), and pins (4).
6. Remove lock nuts (5), cap screws (6), and pivot pins (7).
- 7.

Specification

Loader Bucket—Weight (approximate).....	875 kg 1930 lb.
--	--------------------

Remove loader bucket.

8. Repair or replace loader bucket as necessary.
9. Install pivot pins, cap screws, and lock nuts.
10. Align bucket cylinder rod with the loader bucket.
11. Install pin and snap rings.

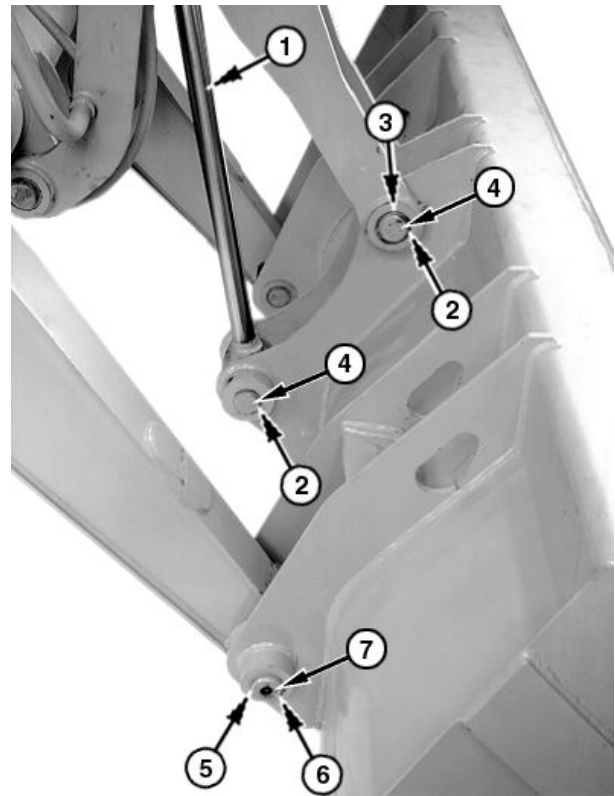

Loader Bucket

- | | |
|-----------------------|-----------------------|
| 1— Bucket Cylinder | 5— Lock Nut (2 used) |
| 2— Snap Ring (4 used) | 6— Cap Screw (2 used) |
| 3— Washer (as needed) | 7— Pivot Pin (2 used) |
| 4— Pin (2 used) | |

12. Align bucket cylinder links with loader bucket.
13. Install pin, washers, and snap rings.

SL78608,000092B -19-26JUL12-1/1

TX1115151A—UN—13JUL12

Loader and Stabilizer Control Valve Remove and Install

1. Park and prepare machine for service. See Park and Prepare for Service Safely. (Group 0001.)
2. Remove right rear wheel. See Rear Wheel Assembly Remove and Install. (Group 0110.)
3. Release hydraulic pressure. See Hydraulic Circuit Pressure Release. (Group 9025-25.)
4. Disconnect battery negative (-) ground cable or turn battery disconnect switch (if equipped) to the OFF position. See Battery Disconnect—If Equipped. (Operator's Manual.)
5. Drain hydraulic oil reservoir or apply vacuum. See Change Hydraulic Reservoir Oil (Operator's Manual) or see Apply Vacuum to Hydraulic Oil Reservoir. (Group 2160.)
6. Remove cap screws (1) and loader and stabilizer control valve cover (2).
7. Remove loader control valve linkage. See Loader Control Valve Linkage Remove and Install—Two Function. (Group 3115.)

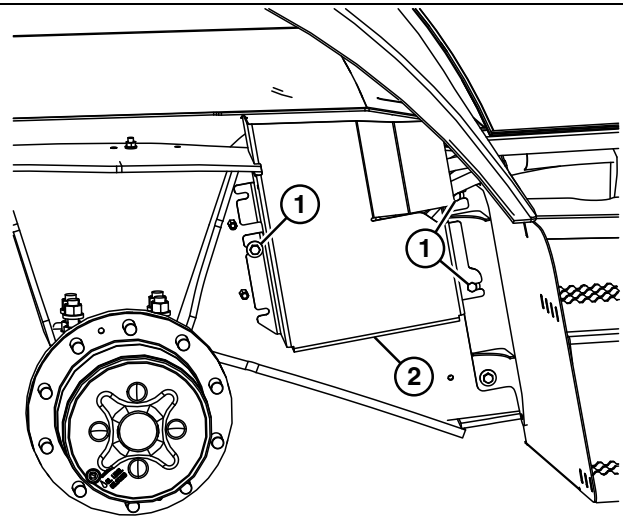

Loader and Stabilizer Control Valve Cover

1— Cap Screw (3 used)

2— Loader and Stabilizer
Control Valve Cover

TX1117338—JUN—06JUL12

Continued on next page

DF89619,00B521B -19-25MAR13-1/2

IMPORTANT: Do not damage OD or ID of new seal during installation. JDG734 Hydraulic Valve Seal Replacer must be used to install lip seal.

Lube seals with hydraulic oil prior to installation.

12. Use JDG734 Hydraulic Valve Seal Replacer and place lip seal (4) on end of tool driver (24) with open side of seal away from tool driver.

NOTE: Lip end of sleeve ID is cone-shaped to compress seal for installation.

13. Carefully slide tool sleeve (23) over seal and tool driver with raised lip of sleeve away from driver. Do not push seal through tool sleeve.

14. Place tool assembly over end of spool with raised lip into counterbore of valve section.

15. Push tool driver to install lip seal into valve housing.

16. Spin tool driver 180 degrees and hold down for several seconds. This will allow air to escape and seal will seat in valve counterbore.

17. Install seals (13 and 12) and plate to loader and stabilizer control valve.

18. Install seals (4 and 3) to loader and stabilizer control valve.

19. Install loader auxiliary spool to loader and stabilizer control valve.

20. Install retainers (10 and 8), spring (9), and cap screw (7).

21. Apply PM38623 and PM37421 Loctite® Thread Lock and Sealer (high strength) to threads of spool and cap screws.

22. Install cap and retaining screws (5). Tighten cap screws to specifications.

Loctite is a trademark of Henkel Corporation

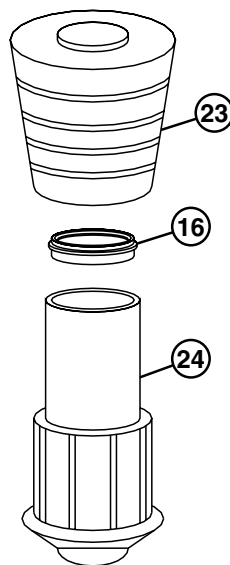

Installation Tool

23— Tool Sleeve
4— Lip Seal

24— Tool Driver

Specification

Retaining	
Screw—Torque.....	9.5 N·m 84 lb.-in.

23. Install plate (2) and spool end cap screws (1). Tighten spool end cap screws to specifications.

Specification

Spool End Cap	
Screw—Torque.....	9.5 N·m 84 lb.-in.

TX1134982 —UN—17APR13

SL78608,0000A25 -19-16APR13-9/9

CAUTION: Prevent crushing injury from heavy component. Use appropriate lifting device.

11. Attach appropriate lifting device to loader bucket cylinder front link (14).

710K Loader Bucket Cylinder Links—Specification

Front Link—Weight
(approximate)..... 44 kg
97 lb.

Rear Link—Weight
(approximate)..... 26 kg
58 lb.

12. Remove snap ring (15) and washers (5 and 16).

13. Remove loader bucket cylinder front link.

- | | |
|------------------------------|--|
| 5— Washer (6 used) | 16— Washer (2 used) |
| 14— Loader Bucket Front Link | 17— Loader Bucket Cylinder Front Link-to-Loader Bucket Pin |
| 15— Snap Ring | 203— Loader Bucket Cylinder |

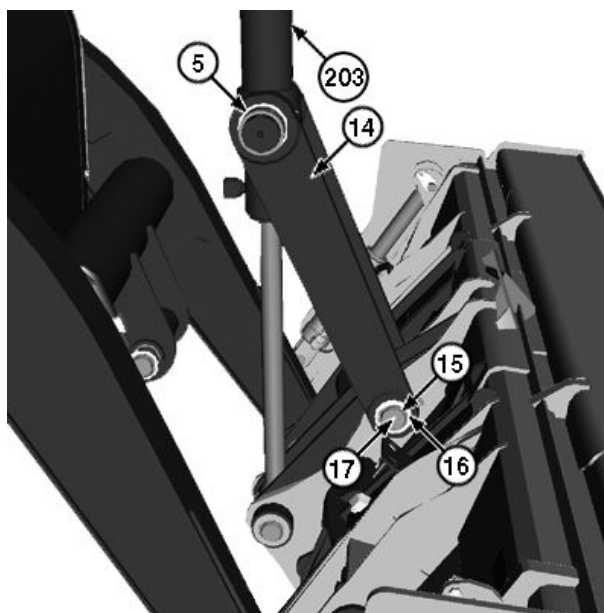

Loader Bucket Front Linkage

TX1116947A —UN—29JUN12

Continued on next page

DI77374.0000E92 -19-15FEB13-2/3

TX1204764—UN—30OCT15

TX1204765—UN—30OCT15

Backhoe Bucket and Bucket Links Remove and Install

NOTE: Procedure applies to backhoe bucket or backhoe coupler (if equipped).

Tools

- D01072AA Bearing and Seal Driver Starter Set
- Use to install bushings.

Other Material

- Loctite® 242® Threadlocker (medium strength)
- Apply to cap screw (6).

Weight Specifications

CAUTION: Prevent possible crushing injury from heavy component. Use appropriate lifting device.

Specification

Driver Link and Power Link Assembly—Weight (approximate).....	85 kg 187 lb
---	-----------------

Machine Preparation

1. Park and prepare machine for service. See Park and Prepare for Service Safely. (Group 0001.)
2. Lower bucket to ground.

Additional Information

Remove pin (3) and set aside driver links (4) to access cap screw (6).

NOTE: To aid in bushing removal, weld three straight beads along inside length of bushing. Do not penetrate outer diameter of bushing with weld. Allow bushing to cool completely before removal.

Loctite and its related brand marks are trademarks of Henkel Corporation

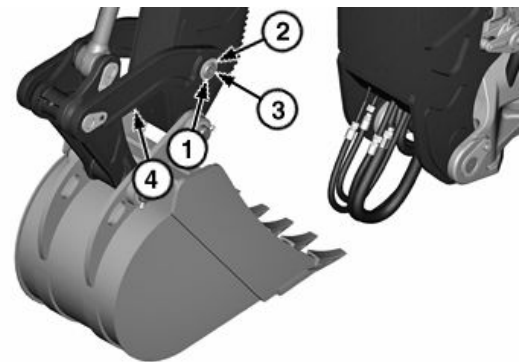

Backhoe Bucket Link Assembly

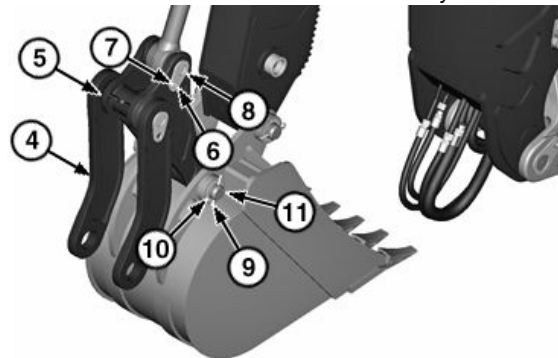

Backhoe Bucket Link Assembly (driver links detached from dipperstick)

- | | |
|-------------------------|-------------------------|
| 1— Snap Ring | 7— Washer |
| 2— Washer (4 used) | 8— Pin |
| 3— Pin | 9— Cotter Pin (4 used) |
| 4— Driver Link (2 used) | 10— Washer (6 used) |
| 5— Power Link | 11— Bucket Pin (2 used) |
| 6— Cap Screw | |

Inspect bushings and replace as necessary.

JD29379,00007C4 -19-11NOV15-1/1

Backhoe Bucket Tooth Tips Remove and Install

There are two types of teeth used on the backhoe bucket.

For removal and installation information see one of the following:

- Replacing Bucket Teeth—Flex Pin. (Operator's Manual.)
- Replacing Bucket Teeth—TK Series. (Operator's Manual.)

PN50483,0002064 -19-16JAN14-1/1

Backhoe Auxiliary Pedal Disassemble and Assemble—Fifth and Sixth Functions

Manual Controls

NOTE: Pedal disassemble and assemble is the same for fifth and sixth function pedal assemblies. This procedure utilizes the fifth function pedal to describe disassemble and assemble steps.

1. Remove nut (1) and linkage assembly (2) from pedal (3).
2. Replace linkage assembly parts as necessary. See [Linkage Disassemble and Assemble](#) at end of this procedure.

- 1— Nut
2— Linkage Assembly
3— Pedal

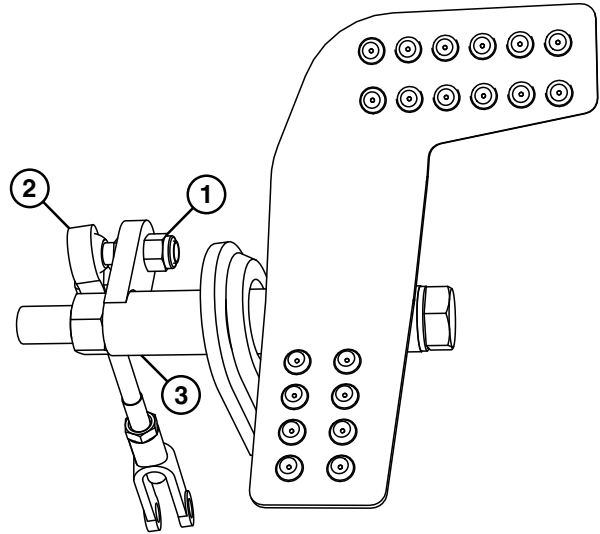

Pedal Assembly

DF89619.00B5218 -19-18FEB13-1/5

TX1117490—UN—09JUL12

3. Remove nut (4), spring washers (5), bushings (6), washer (7), and cap screw (8) from pedal (3).
4. Remove grommet (9) from pedal.
5. Replace parts as necessary.
6. Install grommet to pedal.
7. Install cap screw, washer, bushings, spring washers, and nut (4) to pedal.
8. Tighten nut (4) until spring washers are to specification.

Specification

Spring Washer—Clear-
ance..... 1.5 mm
0.06 in.

9. Install linkage assembly and nut (1).

- 3— Pedal
4— Nut
5— Spring Washer (2 used)
6— Bushing (2 used)
7— Washer
8— Cap Screw
9— Grommet

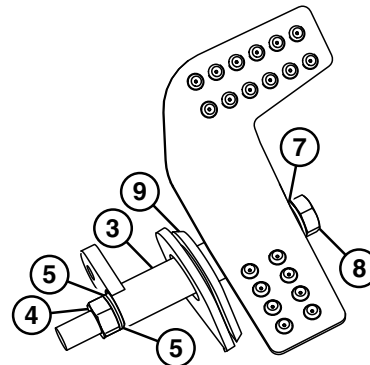

Pedal Assembled

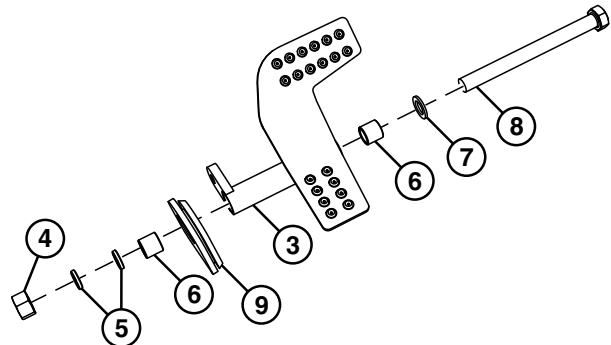

Pedal Disassembled

Continued on next page

DF89619.00B5218 -19-18FEB13-2/5

TX1117493—UN—01AUG12

TX1117494—UN—09JUL12

Control Linkage

6. Remove cap screws (3) and upper control tower cover (4).

3— Cap Screw (2 used)

4— Upper Control Tower Cover

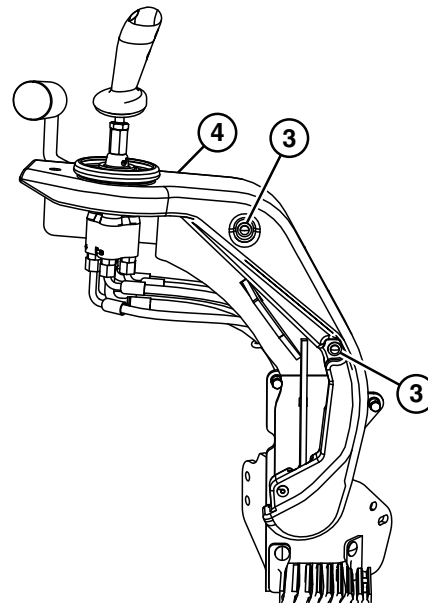

Left Pilot Control Tower

DF89619,00B520C -19-10AUG12-5/6

TX1116437—UN—22JUN12

7. Tag and disconnect all hoses to pilot control (135).

Disconnect STC hose fitting by performing the following:

- a. Clean around the STC fittings.

IMPORTANT: Do not pry against release sleeve or damage to fitting could result.

Do not force release sleeve beyond normal range of travel, otherwise release sleeve could fall off when hose is disconnected. If damaged fitting is connected without the release sleeve installed, fitting will not disconnect again.

- b. Insert JDG1385 STC Hose and Line Fitting Tool between release sleeve and shoulder of fitting.
 c. Gently push, do not pry, release sleeve away from shoulder to disconnect the STC fitting.
 d. Pull hydraulic hose to disconnect.

Close all openings using caps and plugs.

8. Repair or replace pilot controller as necessary. See Backhoe Pilot Control Valve Disassemble and Assemble. (Group 3315.)
 9. Install pilot controller and cap screws (5).
 10. Connect hoses.
 11. Install upper control tower cover and cap screws (3).
 12. Install lower control tower cover and cap screws (1).

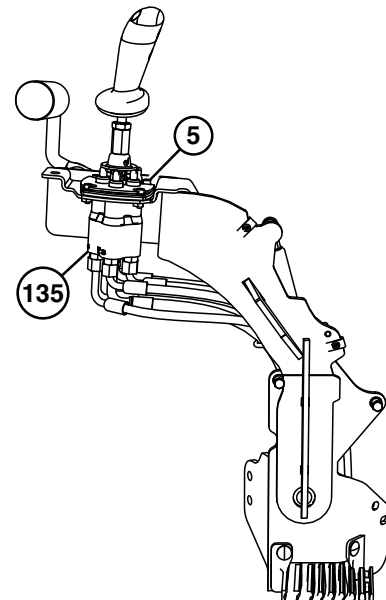

Left Pilot Controller

5— Cap Screw (4 used)

135— Pilot Control (left)

13. Install protective boot.
 14. Connect battery negative (-) ground cable or turn battery disconnect switch (if equipped) to the ON position. See Battery Disconnect—If Equipped. (Operator's Manual.)

DF89619,00B520C -19-10AUG12-6/6

TX1116438—UN—22JUN12

Control Linkage

6. Remove cap screw (11), washers (12), and nut (13).
7. Remove cap screw (14), washers (15), and shock (16).

- | | |
|---------------------|---------------------|
| 11— Cap Screw | 14— Cap Screw |
| 12— Washer (3 used) | 15— Washer (2 used) |
| 13— Nut | 16— Shock |

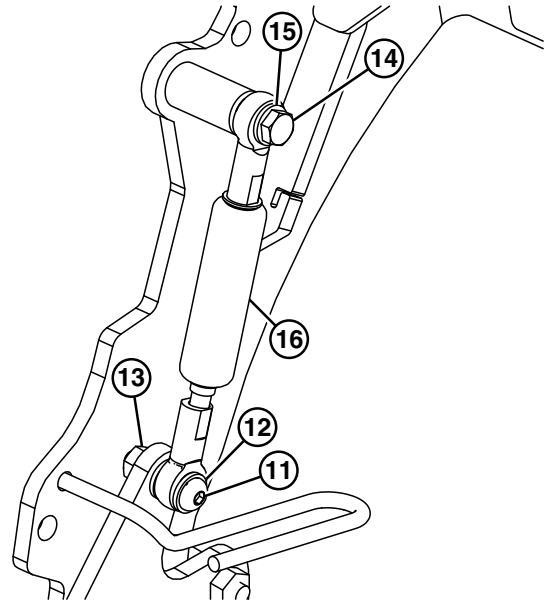

Shock Removal

DF89619,00B5255 -19-23AUG12-7/8

TX1120684—UN—17AUG12

8. Remove snap ring (17), washer (18), and arm (19).
9. Remove bearings (20).
10. Remove cap screws (21), spacers (22), washers (23), and nuts (24).
11. Inspect parts for excessive wear or damage. Replace as necessary.
12. Install nuts (24), washers (22), spacers, and cap screws (21).
13. Install bearings.
14. Install arm, washer (18), and snap ring.

NOTE: Shock should be installed rod end down to extend shock life.

15. Install shock, washers (12 and 15), cap screws (11 and 14), and nut (13).
16. Install wrist support, nut (9), spring washer, washer (7), and cap screw (6).
17. Install washer (5) and adjustment lever.
18. Install hydraulic hoses, hose guide, and plastic fasteners.
19. Install pilot control valve and shields. See Backhoe Pilot Control Valve Remove and Install. (Group 3315.)

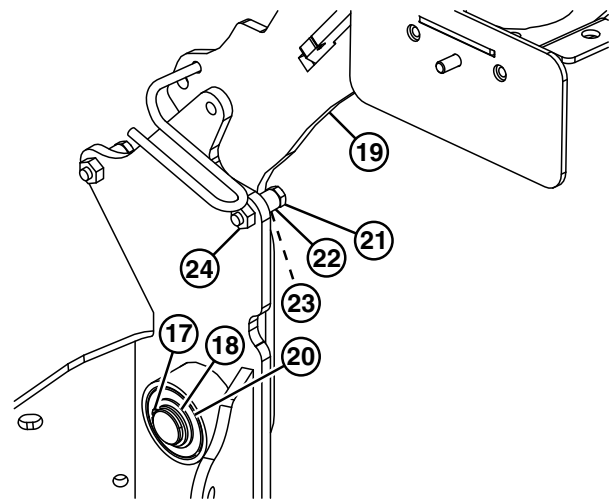

Arm Removal

- | | |
|----------------------|------------------------|
| 17— Snap Ring | 21— Cap Screw (2 used) |
| 18— Washer | 22— Spacer (2 used) |
| 19— Arm | 23— Washer (2 used) |
| 20— Bearing (2 used) | 24— Nut (2 used) |

DF89619,00B5255 -19-23AUG12-8/8

TX1120685—UN—17AUG12

Swing Frame Remove and Install

SPECIFICATIONS	
Swing Frame (310K-410K) Weight (approximate)	129 kg 284 lb.
Swing Frame (710K) Weight (approximate)	298 kg 657 lb.

1. Park and prepare machine for service. See Park and Prepare for Service Safely. (Group 0001.)
2. Remove dipperstick. See Dipperstick Remove and Install. (Group 3340.)
3. Remove boom. See Backhoe Boom Remove and Install. (Group 3340.)

CAUTION: Prevent possible crushing injury from heavy component. Use appropriate lifting device.

4. Connect swing frame (1) to hoist using a lift strap.

Specification

Swing Frame (310K-410K)—Weight (approximate).....	129 kg 284 lb.
---	-------------------

Specification

Swing Frame (710K)—Weight (approximate).....	298 kg 657 lb.
--	-------------------

5. Remove boom lock rod (2) from boom lock hook (3).
6. Remove cap screws (4) and washers (5).
7. Remove hose guard (6) from swing frame.
8. Remove swing cylinder locking snap ring and rod (7) from swing frame.
9. Remove pin (8) from swing frame.
10. Remove upper pivot locking cap screw (9) and lock nut (10) from the swing frame.
11. Remove lower pivot locking cap screw (11) and lock nut (10) from the swing frame.
12. Remove upper pivot pin (12), thrust washer (13), and lower shim (14) from both the top and lower mainframe pivot boss of the swing frame.
13. Remove swing frame.
14. Repair or replace as necessary.

NOTE: Weight of backhoe is supported at the lower pivot. There must be clearance between upper main frame pivot boss and the ears of the swing frame.

15. Install thrust washer on top of lower mainframe pivot boss.

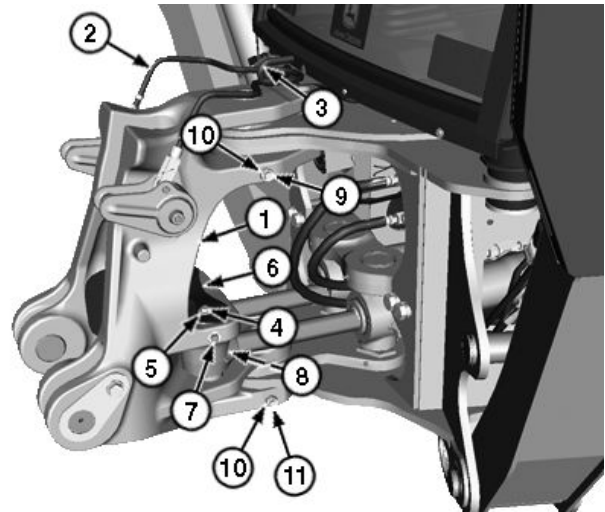

Swing Frame

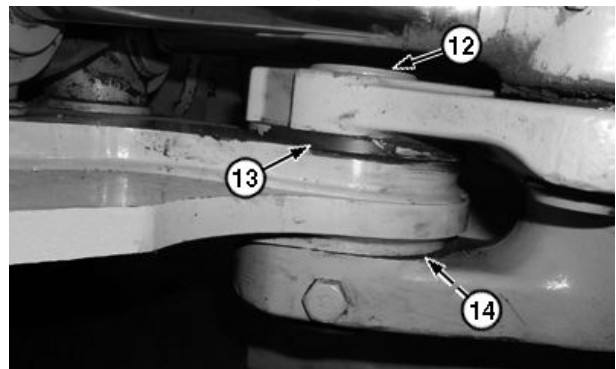

Lower Pivot Joint

- | | |
|---|-----------------------------------|
| 1— Swing Frame | 8— Pin (2 used) |
| 2— Boom Lock Rod | 9— Upper Pivot Locking Cap Screw |
| 3— Boom Lock Hook | 10— Lock Nut (2 used) |
| 4— Cap screw (2 used) | 11— Lower Pivot Locking Cap Screw |
| 5— Washer (2 used) | 12— Upper Pivot Pin |
| 6— Hose Guard | 13— Thrust Washer |
| 7— Swing Cylinder Locking Snap Ring and Rod | 14— Lower Shim |

NOTE: Install swing frame pins so that cross-drilled holes align with holes in swing frame to ease hardware installation.

16. Position swing frame and install upper pivot pin. Secure in position with upper pivot locking cap screw and nut.
17. Align thrust washer with pin bore. Install lower pivot pin and secure in position with lower pivot locking cap screw and nut.
18. Align swing cylinders and install pins from the bottom. Top of pins should be even with casting. Secure in position with swing cylinder locking snap ring and rod.
19. Install hose guard, washers, and cap screws.

Continued on next page

SL78608,0000675 -19-03JUL12-1/2

TX1116033A —UN—03JUL12

TX1114917A —UN—20JUN12

11. Tag and disconnect hoses (13—26).

Disconnect pilot enable and pattern select valve STC fitting lines by performing the following:

- a. Clean around the STC fittings.

IMPORTANT: Do not pry against release sleeve or damage to fitting could result.

Do not force release sleeve beyond normal range of travel, otherwise release sleeve could fall off when hose is disconnected. If damage fitting is connected without the release sleeve installed, fitting will not disconnect again.

- b. Insert JDG1385 STC Hose and Line Fitting Tool between release sleeve and shoulder of fitting.
- c. Gently push, do not pry, release sleeve away from shoulder to disconnect the STC fitting.
- d. Pull hydraulic line to disconnect.

Close all openings using caps and plugs.

12. Remove cap screws (27) to remove hose guides (28) from backhoe control valve mounting plate (29).
13. Remove elbow (30) and tee (31). Close all openings using caps and plugs.

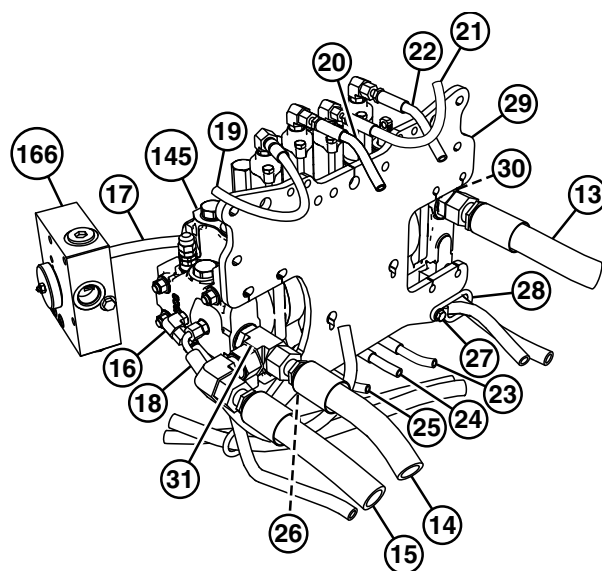

Backhoe Control Valve Forward and Side Connections (six function with auxiliary selective flow shown)

- | | |
|---|---|
| 13— Hydraulic Return Hose | 24— Bucket Spool Pilot Control Hose |
| 14— Hydraulic Supply Hose | 25— Boom Spool Pilot Control Hose |
| 15— Loader and Stabilizer Control Valve Supply Hose | 26— Swing Spool Pilot Control Hose |
| 16— Loader and Stabilizer Control Valve Supply Hose | 27— Cap Screw (2 used) |
| 17— Load Sense Hose (if equipped) | 28— Hose Guide (2 used) |
| 18— Pilot Enable and Pattern Select (PEPS) Manifold Supply Hose | 29— Backhoe Control Valve Mounting Plate |
| 19— Swing Spool Pilot Control Hose | 30— 90° Elbow Fitting (if equipped) |
| 20— Boom Spool Pilot Control Hose | 31— Tee Fitting |
| 21— Bucket Spool Pilot Control Hose | 145— Backhoe Control Valve |
| 22— Crowd Spool Pilot Control Hose | 166— Auxiliary Selective Flow Control Valve (if equipped) |
| 23— Crowd Spool Pilot Control Hose | |

TX1114908—UN—12JUN12

Continued on next page

DF89619,00B51F1 -19-10SEP12-7/9

NOTE: Relief valve installation torque is port size specific. Verify diameter of port with specifications listed below.

- Apply clean hydraulic oil to all internal parts. Install and tighten relief valves to specification.

Circuit Relief Valves—Specification

Relief Valve 22.35 mm (0.88 in.)—Torque.....	45 N·m 33 lb.-ft.
Relief Valve 26 mm (1.06 in.)—Torque.....	61 N·m 45 lb.-ft.

- For installation of backhoe control valve, see Backhoe Control Valve Remove and Install. (Group 3360.)

IMPORTANT: Relief valves must be adjusted when valves are disassembled or replaced. Failure to do so could cause damage to hydraulic system.

- Adjust relief valves. See Circuit Relief Valve Test—With Remote Pump. (Group 9025-25.)

Adjust backhoe load sense relief valve, see Backhoe, Loader, and Steering Load Sense Relief Valve Pressure Test. (Group 9025-25.)

D177374,0000E9B -19-10SEP12-2/2

Backhoe Inlet Section Disassemble and Assemble

SPECIFICATIONS	
Load Sense Relief Valve to Section Body Torque	45 N·m 33 lb.-ft.
Relief Valve Nut Torque	24 N·m 18 lb.-ft.

Inlet Section Disassemble and Assemble

- Remove backhoe load sense relief valve (151). Repair or replace as necessary. See Load Sense Relief Valve Disassemble and Assemble.
- Remove plug (1), O-ring (2), spring (3), and spool (4).
- Remove plugs (5 and 7) and O-rings (6 and 8).

NOTE: Spool is not serviceable individually.

- Inspect parts for wear or damage. Replace as necessary.
- Apply clean hydraulic oil to internal components.
- Install O-rings (6 and 8) and plugs (5 and 7).
- Install spool, spring, O-ring (2), and plug (1).
- Install load sense relief valve. Tighten to specification.

Specification

Load Sense Relief Valve to Section Body—Torque.....	45 N·m 33 lb.-ft.
---	----------------------

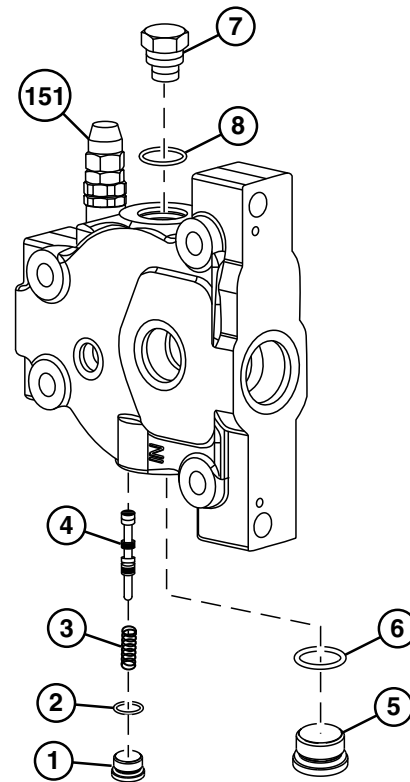

Inlet Section Disassembly

- 1— Plug
- 2— O-Ring
- 3— Spring
- 4— Spool
- 5— Plug

- 6— O-Ring
- 7— Plug
- 8— O-Ring
- 151— Backhoe Load Sense Relief Valve

TX1119794—UN—09AUG12

Continued on next page

DF89619,00B524B -19-22AUG12-1/2

Backhoe Crowd Section Disassemble and Assemble

SPECIFICATIONS	
Detent Cap Screw Torque	9.5 N·m 84 lb.-in.
Detent Body Cap Screw Torque	9.5 N·m 84 lb.-in.
Plate Cap Screw Torque	9.5 N·m 84 lb.-in.
Plug Torque	61 N·m 45 lb.-ft.
Relief Valve Torque	61 N·m 45 lb.-ft.
End Cap, Cap Screw Torque	9.5 N·m 84 lb.-in.

OTHER MATERIAL	
Loctite® Klean 'N Prime	
271 Loctite® Thread Lock and Sealer (high strength)	

Backhoe Crowd Section Disassemble and Assemble—Manual Controls

- Remove crowd circuit relief valve (with anticavitation) (235). Repair or replace as necessary. See [Relief Valve Disassemble and Assemble—With Anticavitation](#).
 - Remove crowd circuit relief valve (no anticavitation) (236). Repair or replace as necessary. See [Relief Valve Disassemble and Assemble—No Anticavitation](#).
 - Remove plugs (1 and 3) and O-rings (2 and 4).
 - Remove springs (7 and 8) and compensator (9).
 - Remove washer (12), spring (13), and poppet (14).
 - Remove cap screws (15), plate (16), wiper (17), and O-ring (18).
 - Remove cap screws (19) and parts (20—27) as an assembly.
 - Remove O-ring (20), wiper (21), and plate (22) from spool (23).
 - Remove detent body (24).
 - Secure spool in vice using protective cover or wood blocks.
 - Remove cap screw (25), spring seats (26), and spring (27).
- NOTE:** Springs (7 and 13), spool, compensator, washer (12), and poppet (14) are not serviceable individually.
- Inspect parts for wear or damage. Replace as necessary.
 - Apply clean hydraulic oil to all parts.
 - Apply PM37509 Loctite Klean 'N Prime and PM37421 Loctite Thread Lock and Sealer (high strength) to threads of spool (23) and cap screw (25).

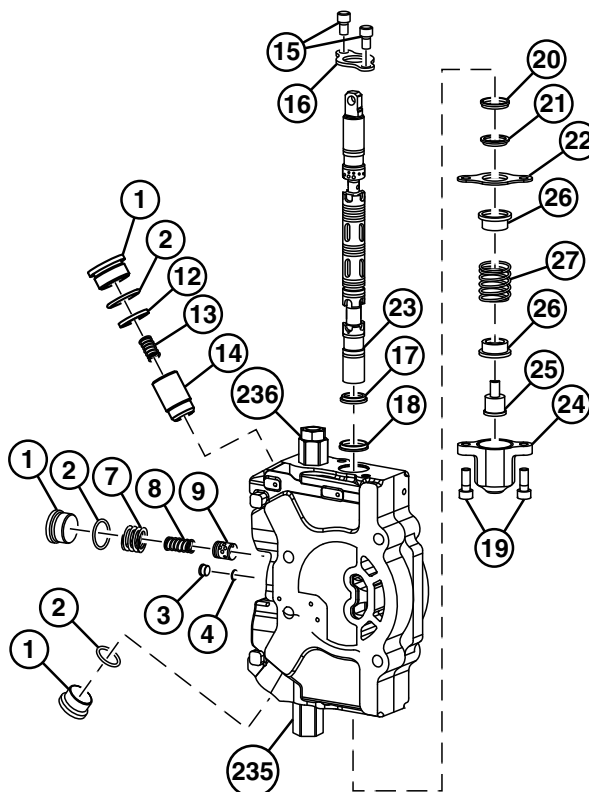

Crowd Section Disassembly—Manual Controls

- | | |
|------------------------|---|
| 1— Plug (3 used) | 18— O-Ring |
| 2— O-Ring (3 used) | 19— Cap Screw (2 used) |
| 3— Plug | 20— O-Ring |
| 4— O-Ring | 21— Wiper |
| 7— Spring | 22— Plate |
| 8— Spring | 23— Spool |
| 9— Compensator | 24— Detent Body |
| 12— Washer | 25— Cap Screw |
| 13— Spring | 26— Spring Seat (2 used) |
| 14— Poppet | 27— Spring |
| 15— Cap Screw (2 used) | 235— Crowd Circuit Relief Valve (with anticavitation) |
| 16— Plate | 236— Crowd Circuit Relief Valve (no anticavitation) |
| 17— Wiper | |

- Install spring (27), spring seats, and cap screw (25) to spool. Tighten to specification.

Specification

Detent Cap Screw—Torque.....	9.5 N·m 84 lb.-in.
------------------------------	-----------------------

- Install plate (22), wiper (21), and O-ring (20).

- Install spool assembly, detent body, and cap screws (19). Tighten to specification.

Specification

Detent Body Cap Screw—Torque.....	9.5 N·m 84 lb.-in.
-----------------------------------	-----------------------

Continued on next page

DF89619,00B524E -19-17OCT13-1/6

TX1145687—UN—15OCT13

Backhoe Extendable Dipperstick Section Disassemble and Assemble—If Equipped

SPECIFICATIONS

Detent Cap Screw Torque	9.5 N·m 84 lb.-in.
Detent Body Cap Screw Torque	9.5 N·m 84 lb.-in.
Plate Cap Screw Torque	9.5 N·m 84 lb.-in.
Plug Torque	61 N·m 45 lb.-ft.

OTHER MATERIAL

Loctite® Klean 'N Prime
271 Loctite® Thread Lock and Sealer (high strength)

- Remove plugs (1, 3, and 5), O-rings (4 and 6), and seals (2).
- Remove springs (9 and 10) and compensator (11).
- Remove washer (14), spring (15), and poppet (16).
- Remove cap screws (17), plate (18), wiper (19), and O-ring (20).
- Remove cap screws (21) and parts (22—29) as an assembly.
- Remove O-ring (22), wiper (23), and plate (24) from spool (25).
- Remove detent body (26).
- Secure spool in vice using protective cover or wood blocks.
- Remove cap screw (27), spring seats (28), and spring (29).

NOTE: Springs (9 and 15), compensator, spool, washer (14), and poppet (16) are not serviceable individually.

- Inspect parts for wear or damage. Replace as necessary.
- Apply clean hydraulic oil to all parts.
- Apply PM37509 Loctite Klean 'N Prime and PM37421 Loctite Thread Lock and Sealer (high strength) to threads of spool (25) and cap screw (27).

- Install spring (29), spring seats, and cap screw (27) to spool. Tighten to specification.

Specification

Detent Cap Screw—Torque.....	9.5 N·m 84 lb.-in.
------------------------------	-----------------------

- Install plate (24), wiper (23), and O-ring (22).

- Install spool assembly, detent body, and cap screws (21). Tighten to specification.

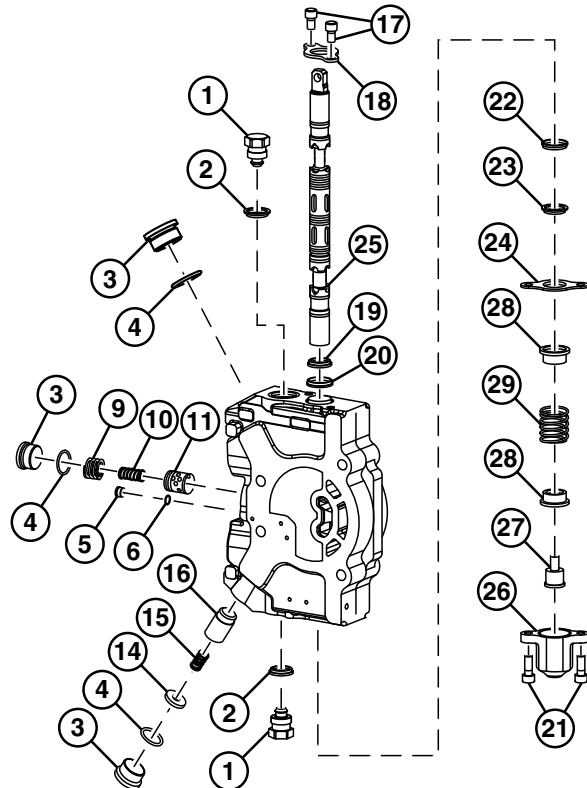

Dipperstick Section Disassembly

- | | |
|------------------------|--------------------------|
| 1— Plug (2 used) | 18— Plate |
| 2— Seal (2 used) | 19— Wiper |
| 3— Plug (3 used) | 20— O-Ring |
| 4— O-Ring (3 used) | 21— Cap Screw (2 used) |
| 5— Plug | 22— O-Ring |
| 6— O-Ring | 23— Wiper |
| 9— Spring | 24— Plate |
| 10— Spring | 25— Spool |
| 11— Compensator | 26— Detent Body |
| 14— Washer | 27— Cap Screw |
| 15— Spring | 28— Spring Seat (2 used) |
| 16— Poppet | 29— Spring |
| 17— Cap Screw (2 used) | |

Specification

Detent Body Cap Screw—Torque.....	9.5 N·m 84 lb.-in.
-----------------------------------	-----------------------

- Install O-ring (20), wiper (19), plate (18), and cap screws (17). Tighten to specification.

Specification

Plate Cap Screw—Torque.....	9.5 N·m 84 lb.-in.
-----------------------------	-----------------------

- Install poppet (16), springs (9, 10, and 15), washer (14), and compensator (11).

TX1145688—UN—15OCT13

5. Remove hose clamp (1) from backhoe bucket cylinder (163).
6. Install identification tags and disconnect hydraulic hoses from backhoe bucket cylinder. Close all openings using caps and plugs.

CAUTION: Prevent possible crushing injury from heavy component. Use appropriate lifting device.

7. Install appropriate lifting device to backhoe bucket cylinder.

Specification

Backhoe Bucket Cylinder—Weight (approximate).....	105 kg 230 lb
---	------------------

8. Remove cap screw (2) and washer (3) from rod end pin (4).
9. Remove rod end pin.
10. Remove snap ring (5) from head end pin (8).
11. Note location of spacers (6) and washers (7) to aid in assembly.
12. Remove head end pin, spacers, and washers (7).
13. Remove backhoe bucket cylinder.
14. Repair or replace backhoe bucket cylinder as necessary. See Backhoe Bucket Cylinder Disassemble and Assemble. (Group 3360.)
15. Install backhoe bucket cylinder.
16. Install washers (7), spacers, head end pin, and snap ring.

Loctite and its related brand marks are trademarks of Henkel Corporation

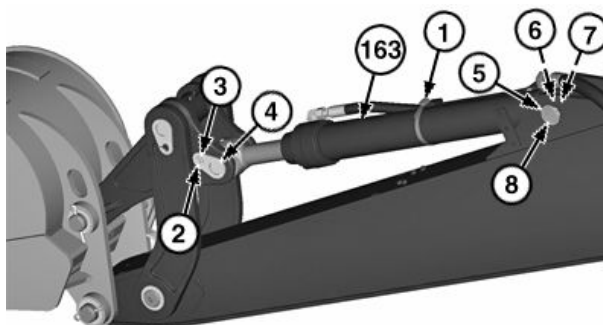

Backhoe Bucket Cylinder

- | | |
|----------------|------------------------------|
| 1— Hose Clamp | 6— Spacer (2 used) |
| 2— Cap Screw | 7— Washer (2 used) |
| 3— Washer | 8— Head End Pin |
| 4— Rod End Pin | 163— Backhoe Bucket Cylinder |
| 5— Snap Ring | |

17. Install rod end pin.
18. Apply Loctite® 242® Threadlocker (medium strength) to cap screw. Install washer (3) and cap screw.
19. Connect backhoe bucket cylinder hydraulic hoses and install hose clamp.
20. Turn battery disconnect switch to ON or connect battery negative (-) cables.
21. Operate backhoe to check for leaks and proper bucket cylinder operation.

TX1204733—UN—29OCT15

JD29379,00007C2 -19-29OCT15-2/2

Backhoe Bucket Cylinder Disassemble and Assemble

For backhoe bucket cylinder repair information, see Cylinder Identification. (CTM120519.)

PN36905,0000014 -19-21APR14-1/1

**Section 99
Dealer Fabricated Tools**

Contents

Page

Group 9900—Dealer Fabricated Tools

DFT1101 Cab and ROPS Lift
Bracket 99-9900-1
DFT1146 Axle Mounting Bracket..... 99-9900-2
DFT1147 Axle Rolling Torque Bar..... 99-9900-3
DFT1162 Clutch Pack Snap Ring
Removal and Installation Tool..... 99-9900-4
DFT1163 MFWD Snap Ring
Removal and Installation Tool..... 99-9900-5
DFT1174 Rear Axle Yoke Adapter
Plate 99-9900-6

CLICK HERE TO **DOWNLOAD** THE COMPLETE MANUAL

- Thank you very much for reading the preview of the manual.
- You can download the complete manual from: www.heydownloads.com by clicking the link below



- Please note: If there is no response to CLICKING the link, please download this PDF first and then click on it.

CLICK HERE TO **DOWNLOAD** THE COMPLETE MANUAL