

310SK, 410K Backhoe Loaders With TMC Repair Manual

(PIN: 1T0310TK__E219607—)

(PIN: 1T0410TK__E219607—)

REPAIR TECHNICAL MANUAL

310SK, 410K Backhoe Loaders With TMC

(PIN: 1T0310TK__E219607—)

(PIN: 1T0410TK__E219607—)

TM12488 14MAY19 (ENGLISH)

**Worldwide Construction
And Forestry Division**

PRINTED IN U.S.A.

CLICK HERE TO **DOWNLOAD** THE COMPLETE MANUAL

- Thank you very much for reading the preview of the manual.
- You can download the complete manual from: www.heydownloads.com by clicking the link below



- Please note: If there is no response to CLICKING the link, please download this PDF first and then click on it.

CLICK HERE TO **DOWNLOAD** THE COMPLETE MANUAL

Avoid High-Pressure Fluids

Inspect hydraulic hoses periodically – at least once per year – for leakage, kinking, cuts, cracks, abrasion, blisters, corrosion, exposed wire braid or any other signs of wear or damage.

Replace worn or damaged hose assemblies immediately with John Deere approved replacement parts.

Escaping fluid under pressure can penetrate the skin causing serious injury.

Avoid the hazard by relieving pressure before disconnecting hydraulic or other lines. Tighten all connections before applying pressure.

Search for leaks with a piece of cardboard. Protect hands and body from high-pressure fluids.

If an accident occurs, see a doctor immediately. Any fluid injected into the skin must be surgically removed within a few hours or gangrene may result. Doctors unfamiliar

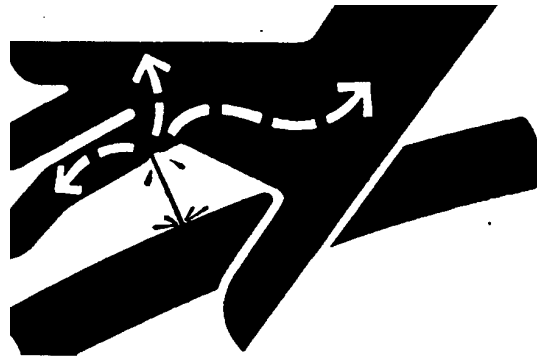

with this type of injury should reference a knowledgeable medical source. Such information is available in English from Deere & Company Medical Department in Moline, Illinois, U.S.A., by calling 1-800-822-8262 or +1 309-748-5636.

SL78608,0000788 -19-04APR12-1/1

X9811 —UN—23AUG88

Avoid High-Pressure Oils

This machine uses a high-pressure hydraulic system. Escaping oil under pressure can penetrate the skin causing serious injury.

Never search for leaks with your hands. Protect hands. Use a piece of cardboard to find location of escaping oil. Stop engine and relieve pressure before disconnecting lines or working on hydraulic system.

If hydraulic oil penetrates your skin, see a doctor immediately. Injected oil must be removed surgically within hours or gangrene could result. Contact a knowledgeable medical source or the Deere & Company Medical Department in Moline, Illinois, U.S.A.

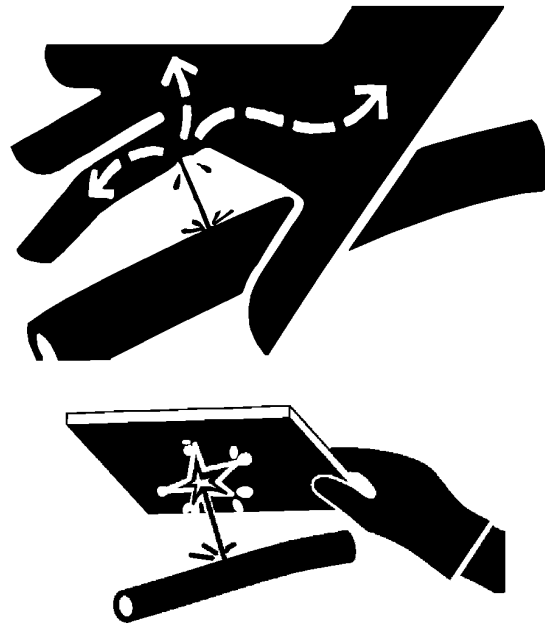

SL78608,0000789 -19-04APR12-1/1

T133509 —UN—15APR13

T133840 —UN—20SEP00

Service Tires Safely

Explosive separation of a tire and rim parts can cause serious injury or death.

Do not attempt to mount a tire unless you have the proper equipment and experience to perform the job.

Always maintain the correct tire pressure. Do not inflate the tires above the recommended pressure. Never weld or heat a wheel and tire assembly. The heat can cause an increase in air pressure resulting in a tire explosion. Welding can structurally weaken or deform the wheel.

When inflating tires, use a clip-on chuck and extension hose long enough to allow you to stand to one side and NOT in front of or over the tire assembly. Use a safety cage if available.

Check wheels for low pressure, cuts, bubbles, damaged rims or missing lug bolts and nuts.

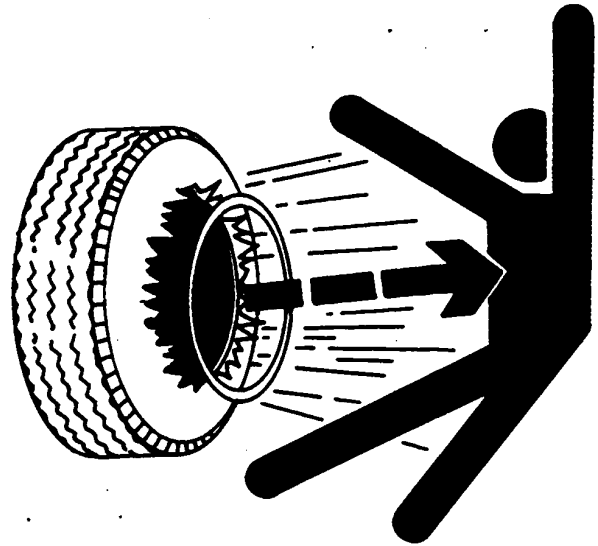

TS211 —JUN—15APR13

SL78608,00007A3 -19-04APR12-1/1

O-Ring Face Seal Fittings With SAE Inch Hex Nut And Stud End For High Pressure Service Recommendations

O-RING FACE SEAL FITTINGS WITH SAE INCH HEX NUT AND STUD END FOR HIGH PRESSURE, ABOVE 27 600 kPa (276 bar) (4000 psi), TORQUE VALUES—Tolerance is +15 -20% unless otherwise specified

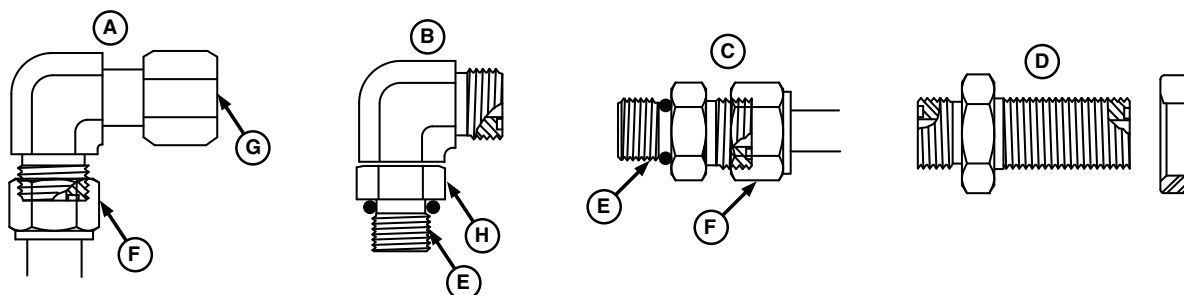

A—90° Swivel Elbow and Tube Nut
 B—90° Adjustable Stud Elbow
 C—Stud Straight and Tube Nut
 D—Bulkhead Union and Nut
 E—Stud End
 F—Tube Nut
 G—Swivel Nut
 H—Hex Nut

Nominal Tube OD or Hose ID			O-Ring Face Seal Hose or Tube Swivel Nut			Bulkhead Nut	
Metric Tube OD	Inch Tube OD or Hose ID		Thread Size	Hex Size	Torque	Hex Size	Torque
mm	Dash Size	mm (in.)	in.	in.	Nm (lb-ft)	in.	Nm (lb-ft)
5	-3	4.78 (0.188)	—	—	—	—	—
6	-4	6.35 (0.250)	9/16-18	11/16	24 (18)	13/16	32 (24)
8	-5	7.92 (0.312)	—	—	—	—	—
10	-6	9.53 (0.375)	11/16-16	13/16	37 (27)	1	42 (31)
12	-8	12.70 (0.500)	13/16-16	15/16	75 (55)	1-1/8	93 (69)
16	-10	15.88 (0.625)	1-14	1-1/8	103 (76)	1-5/16	118 (87)
20	-12	19.05 (0.750)	1-3/16-12	1-3/8	152 (112)	1-1/2	175 (129)
22	-14	22.23 (0.875)	1-3/16-12	—	152 (112)	—	175 (129)
25	-16	25.40 (1.000)	1-7/16-12	1-5/8	214 (158)	1-3/4	247 (182)
32	-20	31.75 (1.250)	1-11/16-12	1-7/8	286 (211)	2	328 (242)
38	-24	38.10 (1.500)	2-12	2-1/4	326 (240)	2-3/8	374 (276)

O-RING STRAIGHT, ADJUSTABLE, AND EXTERNAL HEX PLUG WITH SAE INCH STUD END FOR HIGH PRESSURE, ABOVE 27 600 kPa (276 bar) (4000 psi), TORQUE VALUES—Tolerance is +15 -20% unless otherwise specified

Thread Size	Straight Hex Size ^a	Adjustable Nut Hex Size	Steel or Gray Iron Torque
in.	in.	in.	Nm (lb-ft)
3/8-24	5/8	9/16	18 (13)
7/16-20	5/8	5/8	24 (18)
1/2-20	3/4	11/16	30 (22)
9/16-18	3/4	3/4	37 (27)
3/4-16	7/8	15/16	75 (55)
7/8-14	1-1/16	1-1/16	103 (76)
1-1/16-12	1-1/4	1-3/8	177 (131)
1-3/16-12	1-3/8	1-1/2	231 (170)
1-5/16-12	1-1/2	1-5/8	270 (199)
1-5/8-12	1-3/4	1-7/8	286 (211)
1-7/8-12	2-1/8	2-1/8	326 (240)

^a Straight hex size applies to fittings only and may not be the same as the corresponding plug of the same thread size.

- Inspect fitting and connector sealing surfaces and the O-rings. They must be free of dirt, scratches, nicks, and burrs. O-ring must be free of dirt, cuts, cracks, swelling or flatten condition.

Torque Values

Service Recommendations For O-Ring Boss Fittings With Shoulder

1. Inspect component seal boss seat for dirt or defects.
2. Inspect EOlastic seal (A) for damage. Replace seal or fitting as necessary.

To replace seal, put electrical tape over threads to protect seal. Slide seal over tape and into seal groove of fitting. Remove tape.

3. Tighten fitting to torque value shown on chart.

IMPORTANT: Do not allow hoses to twist when tightening fittings.

NOTE: The L in the Tube Fitting OD Size column indicates "light" designed fitting and the S indicates "heavy" designed fitting.

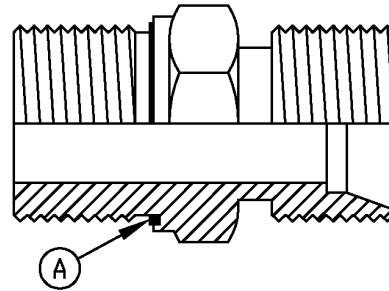

T113957

T113957—UN—06MAR98

Tube Fitting O.D. Size	Metric Thread	Torque Value	
		N-m	lb-ft
6 L	M 10 x 1	20	15
8 L	M 12 x 1.5	30	22
10 L	M 14 x 1.5	45	33
12 L	M 16 x 1.5	60	44
15 L	M 18 x 1.5	80	59
18 L	M 22 x 1.5	130	96
22 L	M 26 x 1.5	190	140
28 L	M 33 x 2	300	221
35 L	M 42 x 2	600	443
42 L	M48 x 2	800	590
6 S	M 12 x 1.5	40	30
8 S	M 14 x 1.5	60	44
10 S	M 16 x 1.5	80	59
12 S	M 18 x 1.5	110	81
14 S	M 20 x 1.5	140	103
16 S	M 22 x 1.5	170	125
20 S	M 27 x 2	250	184
25 S	M 33 x 2	450	332
30 S	M 42 x 2	600	443
38 S	M 48 x 2	800	590

Tube Fitting O.D. Size	Torque Value		
	Inch Size	N-m	lb-ft
6 L	1/8	20	15
8 L	1/4	40	30
10 L	1/4	40	30
12 L	3/8	80	59
15 L	1/2	140	103
18 L	1/2	100	74
22 L	3/4	180	133
28 L	1	300	221
35 L	1-1/4	600	443
42 L	1-1/2	800	590
6 S	1/4	50	37
8 S	1/4	50	37
10 S	3/8	90	66
12 S	3/8	90	66
14 S	1/2	160	118
16 S	1/2	140	103
20 S	3/4	250	184
25 S	1	400	295
30 S	1-1/4	650	479
38 S	1-1/2	800	590

Continued on next page

SL78608.00007B3 -19-04APR12-1/2

⚠ CAUTION: Tire repair should only be performed by a qualified service technician. Do not attempt to mount or demount a tire unless you have proper equipment and experience to perform job safely. Failure to follow proper procedures when mounting or demounting a tire from a wheel or rim can result in explosive separation of a tire and rim parts, causing serious injury or death

10. Turn tire so valve stem is positioned at 12 o'clock. Use a pressure regulating valve with clip-on chuck (6) and extension hose long enough to allow you to stand to one side and NOT in front of tire while inflating.
11. Use only recommended air pressure. Pressure over this limit can cause an explosion.
12. Add air until side flange of tire slides out against rim.
13. Adjust air pressure to proper specification.

6— Pressure Regulating Valve
With Clip-On Chuck

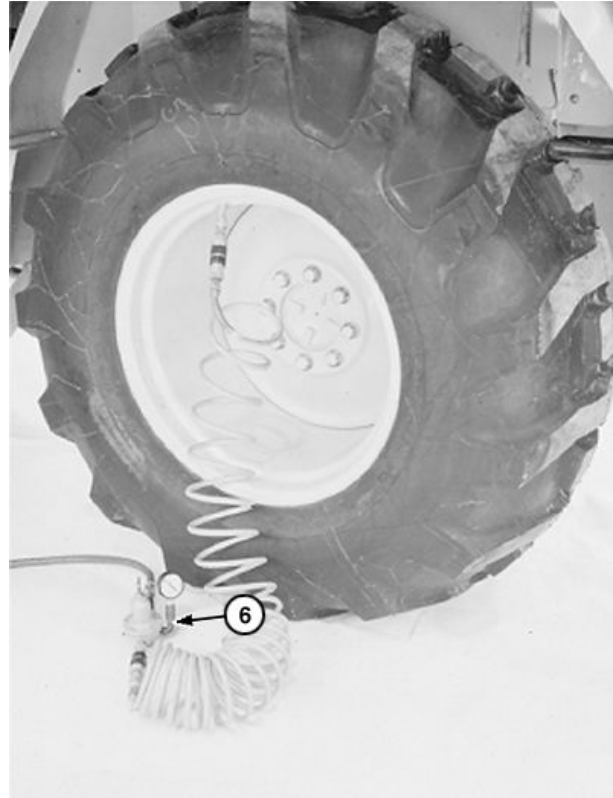

Turn Tire

TX1114144A —UN—11JUN12

DS35042,0001AE9 -19-13JUL12-3/3

Non-Powered Wheel Axles

NOTE: King pin is serviced as an assembly.

8. Inspect king pins for wear or damage. Replace if necessary.

4— King Pin (upper)

5— King Pin (lower)

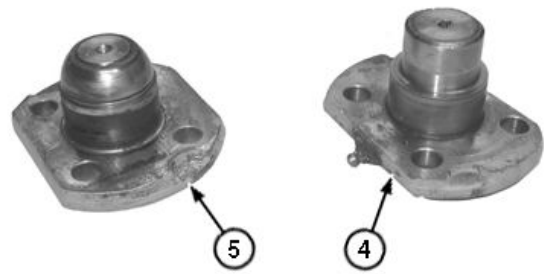

King Pins

Continued on next page

DF89619,00B51FC -19-31AUG12-3/4

TX1114392A—UN—04JUN12

Powered Wheel Axle (MFWD)

2. Pull tapered roller bearing (11) from knuckle housing (10).

10— Knuckle Housing

11— Tapered Roller Bearing

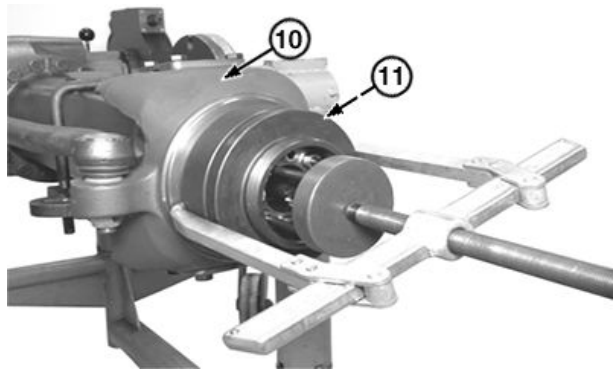

Tapered Roller Bearing

ST02240,000004B -19-28NOV17-8/42

XJ1241996—UN—25JUL17

3. Remove seal ring (12) from wheel hub (5).

5— Wheel Hub

12— Seal Ring

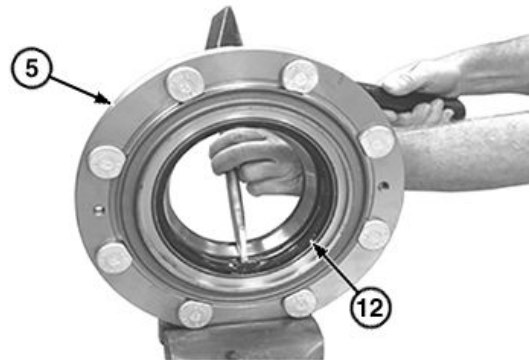

Seal Ring

ST02240,000004B -19-28NOV17-9/42

XJ1241997—UN—25JUL17

4. Remove tapered roller bearing cups (14) from wheel hub (5). Remove and replace O-ring (13).

5— Wheel Hub
13— O-Ring

14— Tapered Roller Bearing Cup (2 used)

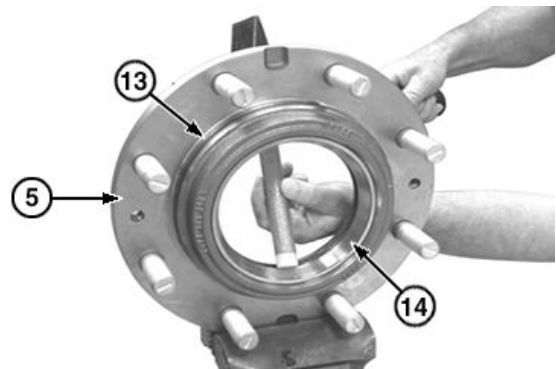

Tapered Roller Bearing Cups

Continued on next page

ST02240,000004B -19-28NOV17-10/42

XJ1241998—UN—25JUL17

Powered Wheel Axle (MFWD)

12. Remove spacer (43) and bushing (33) from bevel gear drive.

33— Bushing

43— Spacer

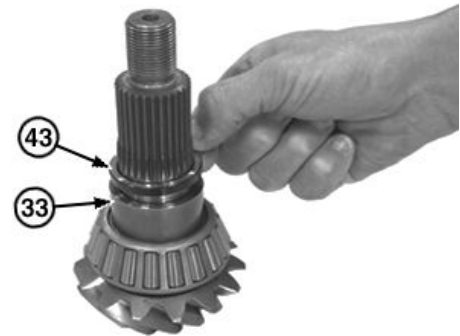

Bevel Gear Drive Spacer and Bushing

ST02240,000004B -19-28NOV17-37/42

XJ1242032—UN—25JUL17

13. Remove tapered roller bearing (11) from bevel gear drive.

11— Tapered Roller Bearing



Bevel Gear Drive Tapered Roller Bearing

ST02240,000004B -19-28NOV17-38/42

XJ1242033—UN—25JUL17

14. Remove shaft seal (30) and tapered roller bearing (11) from axle housing.

11— Tapered Roller Bearing

30— Shaft Seal

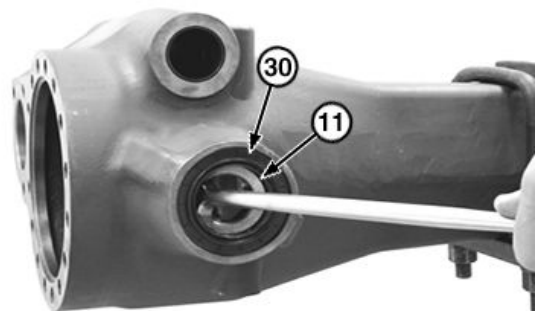

Axle Housing Shaft Seal and Tapered Roller Bearing

Continued on next page

ST02240,000004B -19-28NOV17-39/42

XJ1242034—UN—25JUL17

Powered Wheel Axle (MFWD)

NOTE: Install axle housings together without O-ring to get accurate shim calculations.

23. Remove O-ring (32). Install axle housings (33) together.

32— O-Ring

33— Axle Housing (2 used)

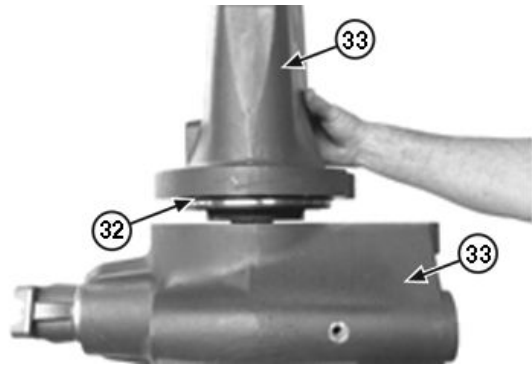

Axle Housings

JD29379,0000210 -19-24DEC18-18/61

TX1119613A —UN—08AUG12

NOTE: If shim calculation was done correctly, the gap width should be at approximate specification.

24. Check specified gap (34) between axle housings. Take several measurements at different locations to determine average value.

Specification

Axle Housings—Gap (approximate).....	0.10 mm
	0.004 in

34— Gap

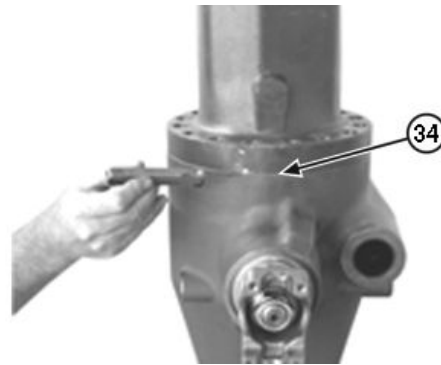

Axle Housings Gap Check

JD29379,0000210 -19-24DEC18-19/61

TX1119614A —UN—08AUG12

25. Install axle housing cap screws (35) and tighten to specification.

Specification

Axle Housing Cap Screws—Torque.....	280 N·m
	210 lb·ft

35— Axle Housing Cap Screw (5 used)

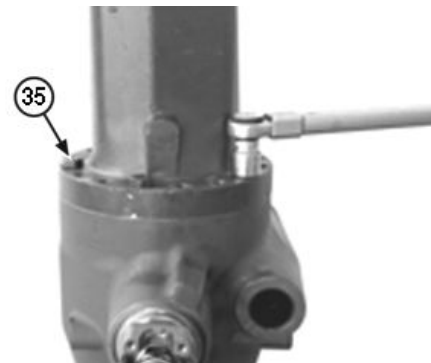

Axle Housings Cap Screws

Continued on next page

JD29379,0000210 -19-24DEC18-20/61

TX1119615A —UN—08AUG12

Powered Wheel Axle (MFWD)

Knuckle Housing Install

NOTE: For ease of assembly, turn drive shaft during installation until splines engage in differential.

1. Install knuckle housing and drive shaft (1) in axle housing (2).

1— Knuckle Housing and Drive Shaft 2— Axle Housing

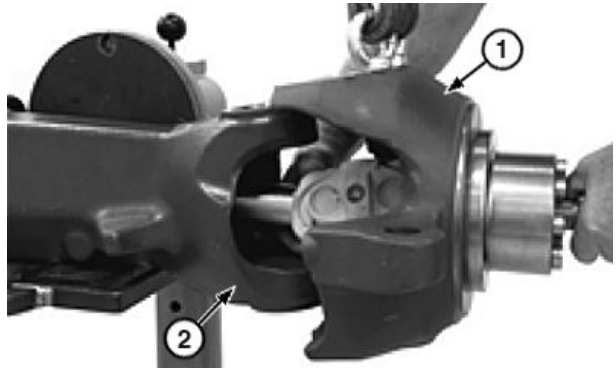

Knuckle Housing and Drive Shaft

TX1035981A—UN—05FEB08

JD29379,0000210 -19-24DEC18-43/61

2. Coat lower and upper king pins (3 and 4) with multipurpose grease. Install lower and upper king pins into knuckle housing.

1— Knuckle Housing and Drive Shaft 4— Upper King Pin
3— Lower King Pin

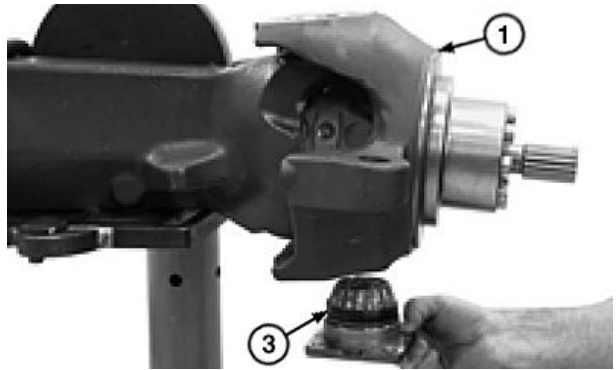

Lower King Pin

TX1119758A—UN—07AUG12

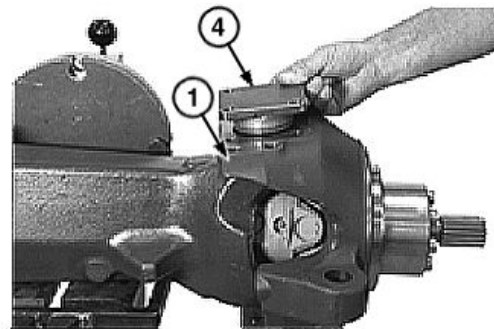

Upper King Pin

TX1119759A—UN—07AUG12

Continued on next page

JD29379,0000210 -19-24DEC18-44/61

Powered Wheel Axle (MFWD)

10. Install bevel gears (14), thrust washers (15), and pinion shaft (13).

11. Install pinion shaft pin (12) to retain pinion shaft.

12— Pinion Shaft Pin
13— Pinion Shaft

14— Bevel Gear (2 used)
15— Thrust Washer (2 used)

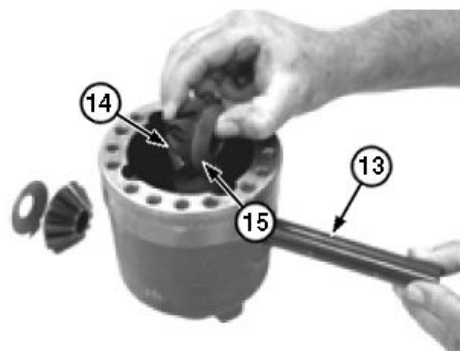

Pinion Shaft and Bevel Gears



Pinion Shaft Pin

Continued on next page

JD29379,0000211 -19-13SEP12-7/12

TX1119807A —UN—07AUG12

TX1119806A —UN—07AUG12

Group 0250 Axle Shaft, Bearings, and Reduction Gears

Service Brakes Inspection

1. Remove plugs from right and left side brake inspection ports (1 and 2).

NOTE: If axle is removed from machine, skip steps 2 and 3 and apply hydraulic pressure directly to axle service brake ports using a manually operated hydraulic pump.

2. Start engine. Do not release park brake.
3. Apply service brakes.

1— Right Side Brake Inspection Port 2— Left Side Brake Inspection Port

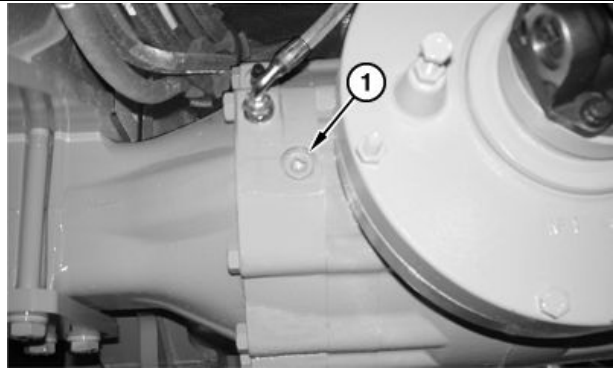

Right External Inspection Port

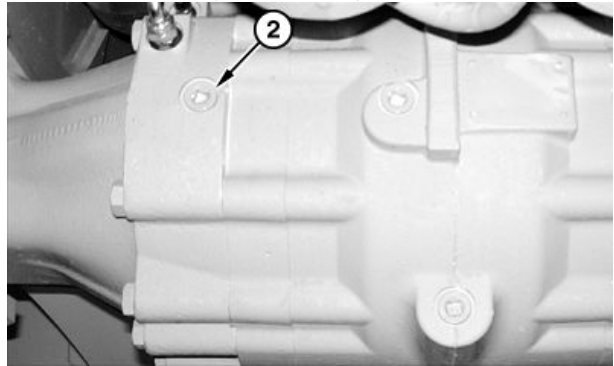

Left Side External Inspection Port

TX1114843A —UN—25MAY12

TX1114844A —UN—25MAY12

Continued on next page

DF89619,00B51EE -19-21JUN12-1/2

Axle Shaft, Bearings, and Reduction Gears

21. Remove cap screws (30) and remove coupling ring (31).

30— Cap Screw (3 used)

31— Coupling Ring

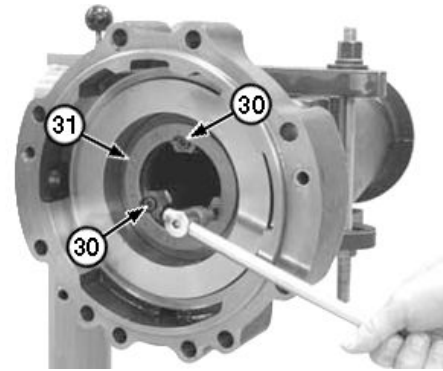

Coupling Ring

TX1119911A —UN—06SEP12

JD29379.0000213 -19-08JUN17-17/32

22. Preload disk spring (33).

23. Remove snap ring (34) and washer (35).

33— Disk Spring
34— Snap Ring

35— Washer

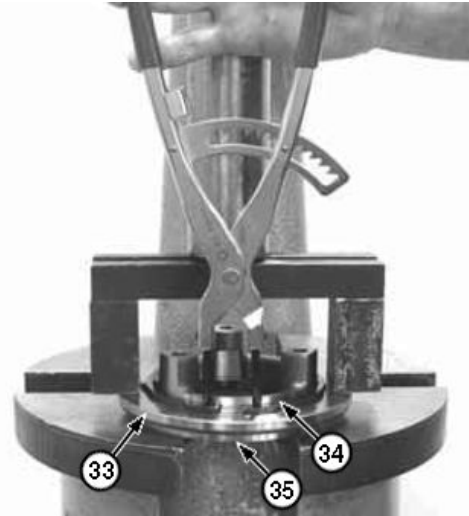

Snap Ring Bevel Springs

TX1119915A —UN—09AUG12

JD29379.0000213 -19-08JUN17-18/32

⚠ CAUTION: Prevent possible personal injury. Wear proper face and body protection when using compressed air.

24. Using compressed air, remove piston (36).

36— Brake Piston



Brake Piston

TX1022393A —UN—23APR07

Continued on next page

JD29379.0000213 -19-08JUN17-19/32

11. Apply marking ink to teeth of ring gear (16) for checking contact pattern later.

CAUTION: Prevent possible crushing injury from heavy component. Use appropriate lifting device.

12. Install differential (24).

Specification

Differential—Weight
(approximate)..... 23 kg
50 lb.

16— Ring Gear

24— Differential

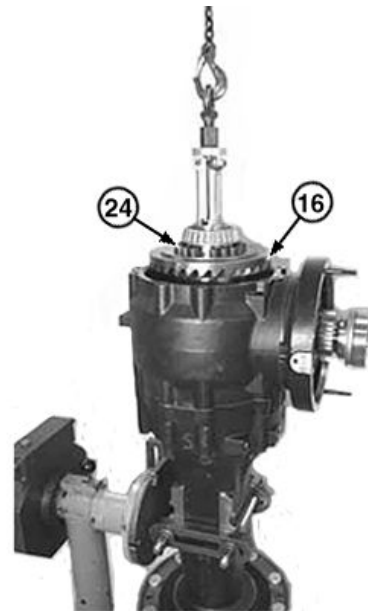

Differential Installation

TX1121517A —UN—30AUG12

JD29379,0000219 -19-17APR18-10/43

13. Measure and record dimension I using straight edge (25) and a depth gauge (26).

Example of Dimension (I)

Flange mounting surface-to-outer bearing cup	6.64 mm 0.261 in.
--	----------------------

25— Straight Edge

26— Depth Gauge

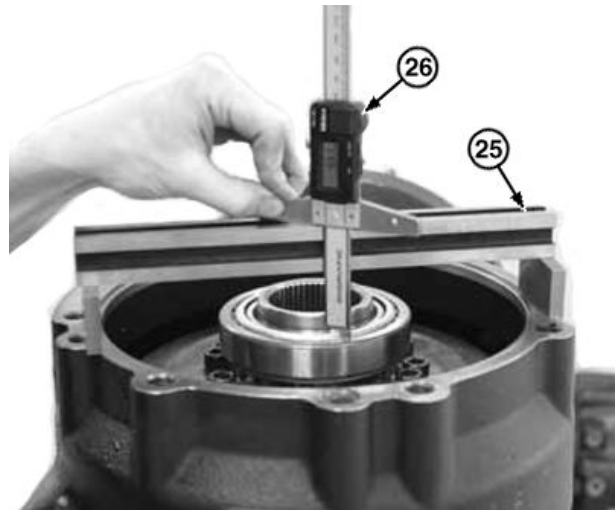

Dimension I

TX1121518A —UN—29AUG12

Continued on next page

JD29379,0000219 -19-17APR18-11/43

Axle Shaft, Bearings, and Reduction Gears

44. Install cap screws (77) and tighten to specification.

Specification

Axle Housing Cap
Screw—Torque.....195 N·m
144 lb.-ft.

77— Cap Screw (12 used)

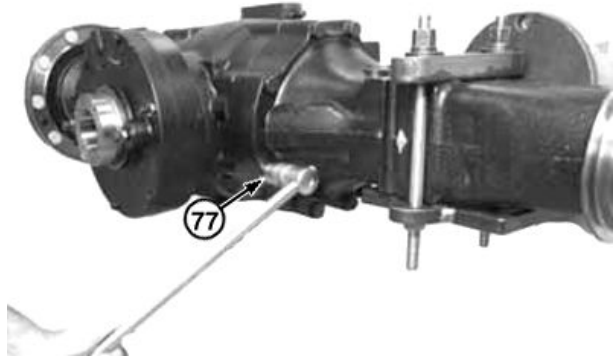

Axle Housing Cap Screws

JD29379,0000219 -19-17APR18-31/43

TX1121542A —UN—29AUG12

45. Press wheel studs (79) into wheel hub (80) until bottomed.

79— Wheel Stud (10 used) 80— Wheel Hub

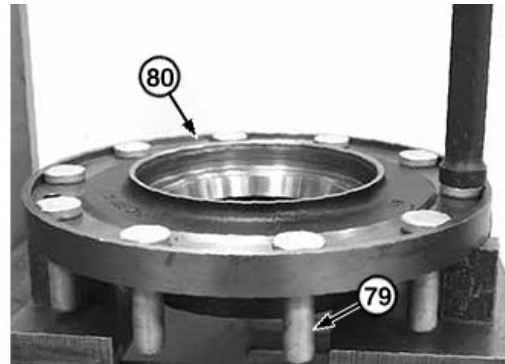

Wheel Studs

JD29379,0000219 -19-17APR18-32/43

TX1121543A —UN—29AUG12

IMPORTANT: Prevent wheel studs from pushing out of wheel hub and damaging threads. Wheel hub must not be supported by wheel studs.

46. Install outer bearing cups (81) using JDG10524 Driver (82) and JDG10525 Handle (83).

81— Outer Bearing Cup (2 used) 83— JDG10525 Handle
82— JDG10524 Driver

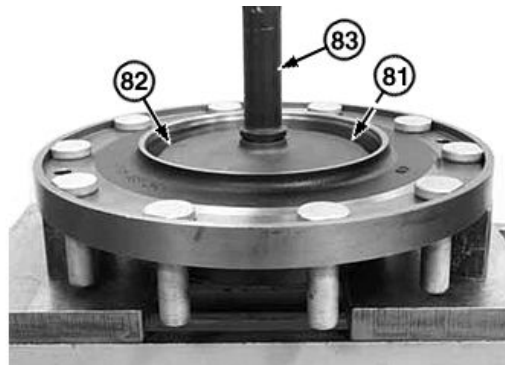

Outer Bearing Cup

Continued on next page

JD29379,0000219 -19-17APR18-33/43

TX1121544A —UN—05SEP12

Axle Shaft, Bearings, and Reduction Gears

NOTE: It is recommended to reuse shim found in disassembly of park brake.

20. Install shim (32).

32— Shim



Shim Installation

TX1120718A —UN—20AUG12

JD29379,0000216 -19-22DEC18-14/35

21. Install outer bearing cup (33).

33— Outer Bearing Cup

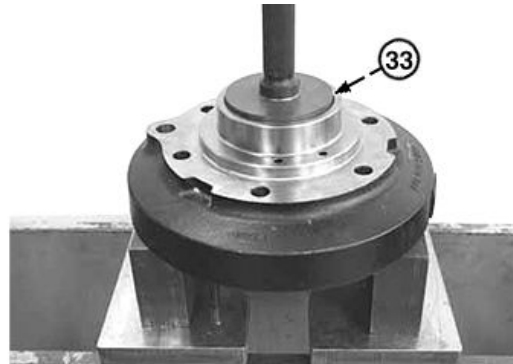

Outer Bearing Cup

TX1120719A —UN—20AUG12

JD29379,0000216 -19-22DEC18-15/35

22. Install inner bearing cup (31).

31— Inner Bearing Cup



Inner Bearing Cup

TX1120721A —UN—20AUG12

Continued on next page

JD29379,0000216 -19-22DEC18-16/35

Gear Tooth Contact Pattern Check

IMPORTANT: Gear tooth contact pattern must be checked on the coast side and drive side with a load applied. The pattern may be correct on the drive side and incorrect on the coast side causing the differential to “whine” when it is not engaged.

1. Apply grease to several teeth of ring gear with a load applied.

2. Apply pressure to park brake using a hydraulic hand pump or park brake release screws. If park brake release screws are used, return them to original position after test is complete.
3. Turn pinion in both directions to determine gear-tooth contact pattern. If pattern is not correct, cone point distance must be increased or decreased.

DF89619,00B51EF -19-31AUG12-1/5

Contact Pattern Check

DF89619,00B51EF -19-31AUG12-2/5

1 Ideal Tooth Contact Pattern

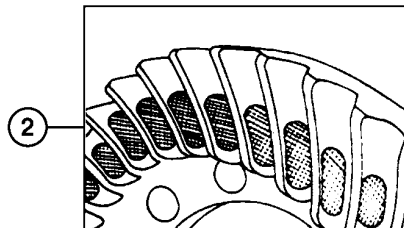
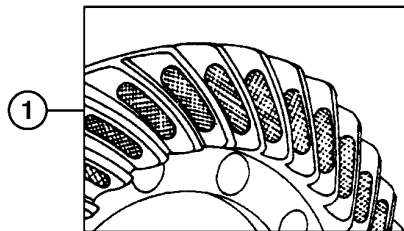

TX1120433 —UN—15AUG12

Ideal Tooth Contact Pattern

- 1— Coast Side (concave)
- 2— Drive Side (convex)

Does contact pattern match?

YES: Checks complete.

NO: Contact pattern at top of gear tooth indicates pinion shim is too thick. Go to Cone Point Decrease.

Contact pattern at bottom of gear tooth indicated pinion shim is too thin. Go to Cone Point Increase.

Continued on next page

DF89619,00B51EF -19-31AUG12-3/5

CAUTION: Prevent possible crushing injury from heavy component. Use appropriate lifting device.

Specification

Transmission—Weight
 (approximate)..... 247 kg
 545 lb.

22. Support transmission using JT01642A Low-Lift Transmission Jack (36). Fasten jack to transmission as follows:

- a. Install appropriately sized shim (37) between jack and bottom of transmission as shown.
- b. Raise and adjust low-lift jack until jack mounting plate and block are tight against bottom of transmission.
- c. Fasten jack to transmission using D01004AA Universal Mounting Arms (38).
- d. To provide as much offset and stability as possible, fasten angle brackets (39) to transmission so each points in opposite direction, then fasten mounting arms to opposite (diagonal) corners of mounting plate.
- e. Make sure all mounting arm hardware is tight before removing transmission.

36— JT01642A Low-Lift
 Transmission Jack
 37— Shim (2 used)

38— D01004AA Universal
 Mounting Arm (2 used)
 39— Angle Bracket

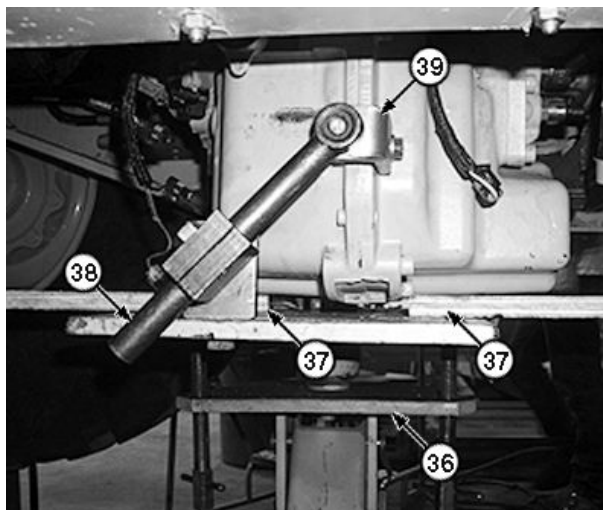

Low Lift Transmission Jack and Mounting Brackets (right side)

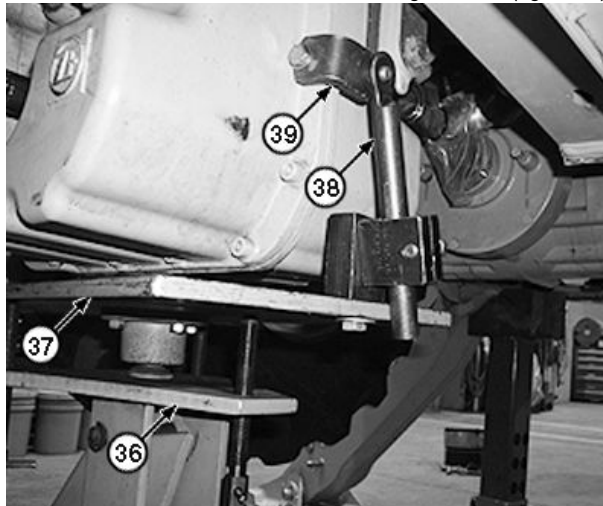

Low Lift Transmission Jack and Mounting Brackets (left side)

TX1117162A—UN—05JUL12

TX1117163A—UN—05JUL12

Continued on next page

JG81906,00009BB -19-08MAY13-12/14

6. Remove plug (11), O-ring (12), piston (13), shims (14), and compression spring (15). Note thickness of shims for ease of assembly.

11— Plug
12— O-Ring
13— Piston

14— Shim (as required)
15— Compression Spring
16— System Relief Port

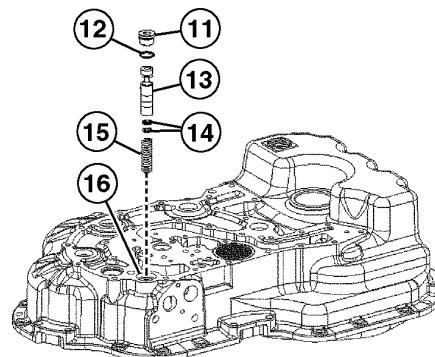

System Pressure Regulating Valve

JD29379,00001EC -19-08SEP17-3/5

TX1031549 —UN—08NOV07

7. Remove torque converter relief valve (18).

18— Torque Converter Relief Valve

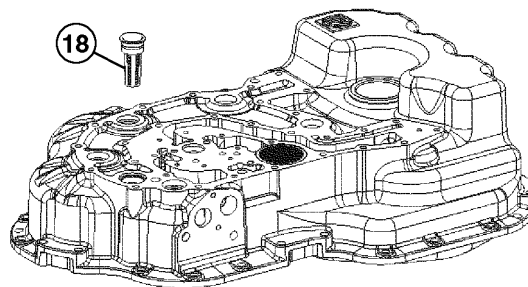

Torque Converter Relief Valve

JD29379,00001EC -19-08SEP17-4/5

TX1118334 —UN—20JUL12

NOTE: Remove pins (20) only if necessary.

8. Remove pins (20) and screen (21).

9. **210K and 310K Only:**

Remove set screw (22).

20— Pin (2 used)
21— Screen

22— Set Screw

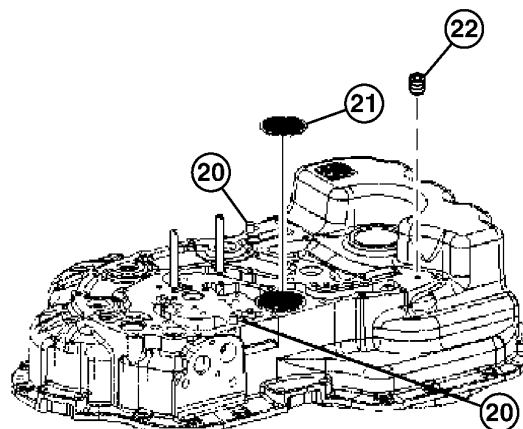

Guide Pins and Screen

JD29379,00001EC -19-08SEP17-5/5

TX1118335 —UN—20JUL12

9. Remove retainer (21) and compression spring (20).

20— Compression Spring

21— Retainer

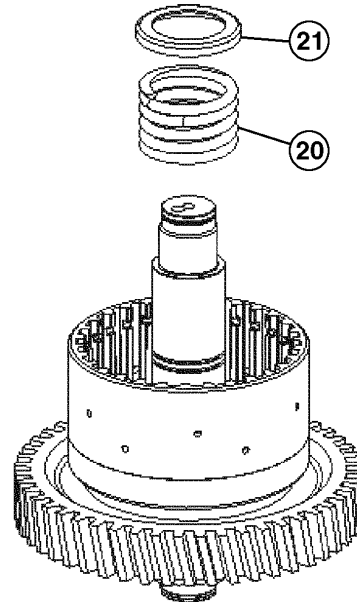

Compression Spring and Retainer

JD29379,00001F1 -19-24AUG15-9/26

TX1020446—UN—11APR07

⚠ CAUTION: Prevent possible personal injury. Wear proper face and body protection when using compressed air.

10. Remove piston (23) using compressed air through oil passage (22).

22— Oil Passage

23— Piston

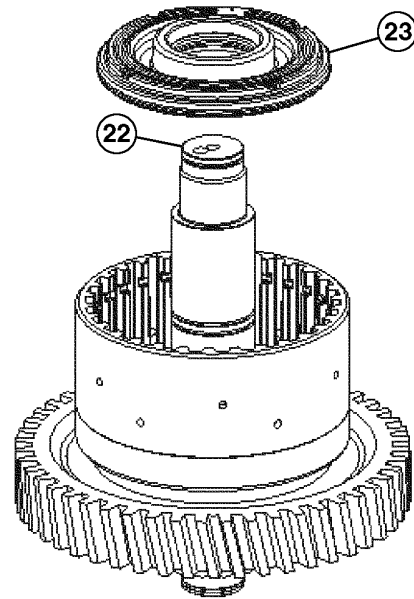

Piston

Continued on next page

JD29379,00001F1 -19-24AUG15-10/26

TX1020447—UN—11APR07

First Speed and Third Speed Clutch Disassemble and Assemble

SPECIFICATIONS

Applied to Clutch End Plate Force (approximate)	20 N 4.5 lb.
First Speed Clutch (K1) Distance	2.0—2.3 mm 0.079—0.118 in.
Third Speed Clutch (K3) Distance	1.8—2.1 mm 0.071—0.083 in.

ESSENTIAL TOOLS

JDG10510 Assembly Aid

1. Remove seal ring (1).

1— Seal Ring

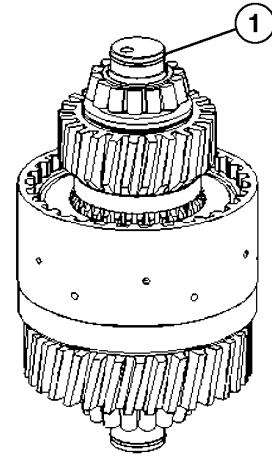

Seal Ring

TX1021965—UN—23APR07

Continued on next page

JD29379,00001F2 -19-28SEP15-1/25

25. Install end plate (12) with flat side down on disk and plate assembly.

26. Install snap ring (11).

11— Snap Ring

12— End Plate

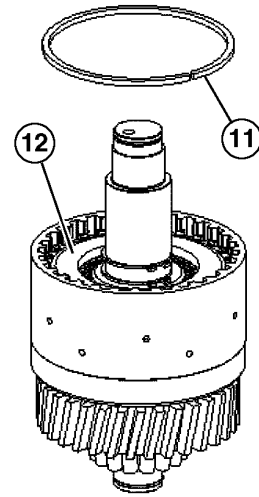

Snap Ring and End Plate

Continued on next page

JD29379,00001F2 -19-28SEP15-20/25

TX1021982—UN—23APR07

12. Apply pressure to thrust washer (18) using JDG10510 Assembly Aid (13) and remove snap rings (24).

13. Remove thrust washer (18) and disc springs (23).

- | | |
|---------------------------|--------------------------|
| 13— JDG10510 Assembly Aid | 23— Disc Spring (7 used) |
| 18— Thrust Washer | 24— Snap Ring (2 used) |

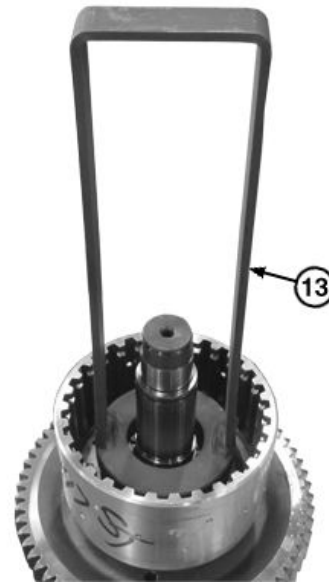

JDG10510 Assembly Aid



Snap Rings

TX1201420A—UN—16SEP15

TX1201418A—UN—17SEP15

Continued on next page

BE78919,000013F -19-28OCT15-7/12

16. Preload disc springs using DFT1163 MFWD Snap Ring Removal and Installation Tool (9) and install snap ring (8). For specifications on DFT1163, see DFT1163 MFWD Snap Ring Removal and Installation Tool. (Group 9900.)

8— Snap Ring

9— DFT1163 MFWD Snap Ring Removal and Installation Tool

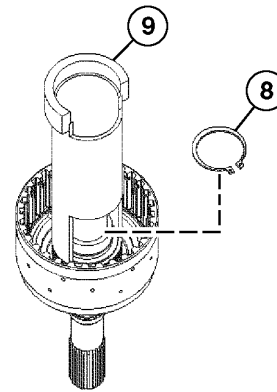

Disc Spring Snap Ring Installation

BE78919,000013D -19-28SEP15-10/15

TX1021324 —UN—25APR07

17. Starting with a plate (23), alternately install plates and discs (22).

22— Disc (12 used)

23— Plate (12 used)

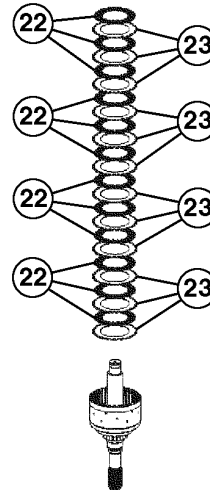

Plate and Disc Installation

Continued on next page

BE78919,000013D -19-28SEP15-11/15

TX1021344 —UN—23APR07

Transmission Outer Components Install

SPECIFICATIONS	
Plug (18) Torque	15 N·m 133 lb.-in.
Plug (19) Torque	28 N·m 21 lb.-ft
Plug (20) Torque	6 N·m 53 lb.-in.
Orifice Torque	10 N·m 89 lb.-in.
Filter Head Cap Screw Torque	23 N·m 204 lb.-in.

ESSENTIAL TOOLS	
JDG10481 Seal Installer	
JDG10483 Driver Tool	

1. Install plugs (18—20). Tighten to specification.

Specification

Plug (18)—Torque..... 15 N·m
133 lb.-in.

Specification

Plug (19)—Torque..... 28 N·m
21 lb.-ft

Plugs

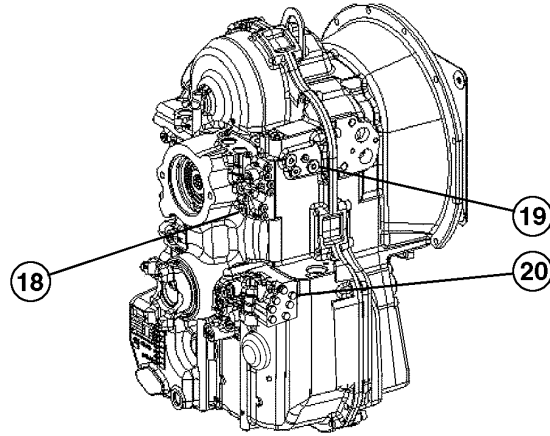

18— Plug
19— Plug

20— Plug

Specification

Plug (20)—Torque..... 6 N·m
53 lb.-in.

JD29379,00001EA -19-17SEP12-1/6

TX1059915 —UN—28MAY09

2. Install directional clutch orifices (14) and first, second, and third speed clutch orifices (15—17). Tighten to specification.

Specification

Orifice—Torque..... 10 N·m
89 lb.-in.

- | | |
|--------------------------------|---------------------------------|
| 14— Directional Clutch Orifice | 16— Second Speed Clutch Orifice |
| 15— First Speed Clutch Orifice | 17— Third Speed Clutch Orifice |

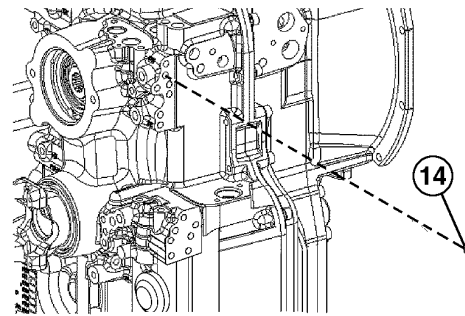

Directional Clutch Orifice

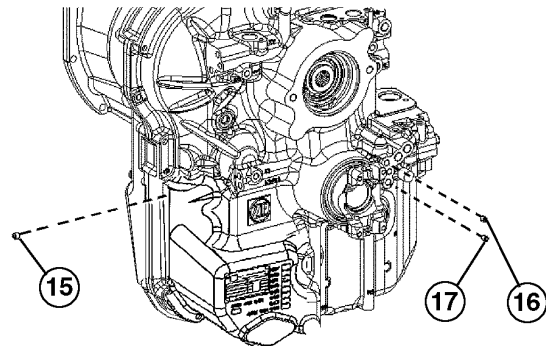

Gear Clutch Orifices

Continued on next page

JD29379,00001EA -19-17SEP12-2/6

TX1059913 —UN—28MAY09

TX1059914 —UN—28MAY09

Section 04 Engine

Contents

Page

Group 0400—Removal and Installation

John Deere Engine Operation	04-0400-1
Engine Remove	04-0400-1
Engine Install	04-0400-7

CLICK HERE TO **DOWNLOAD** THE COMPLETE MANUAL

- Thank you very much for reading the preview of the manual.
- You can download the complete manual from: www.heydownloads.com by clicking the link below



- Please note: If there is no response to CLICKING the link, please download this PDF first and then click on it.

CLICK HERE TO **DOWNLOAD** THE COMPLETE MANUAL

Removal and Installation

11. Rotate transmission oil fill tube (25) toward engine, install bolts (23), and nuts (24).

12. Tighten cap screws (22).

22— Cap Screw (2 used)
23— Bolt (2 used)

24— Nut (2 used)
25— Transmission Oil Fill Tube

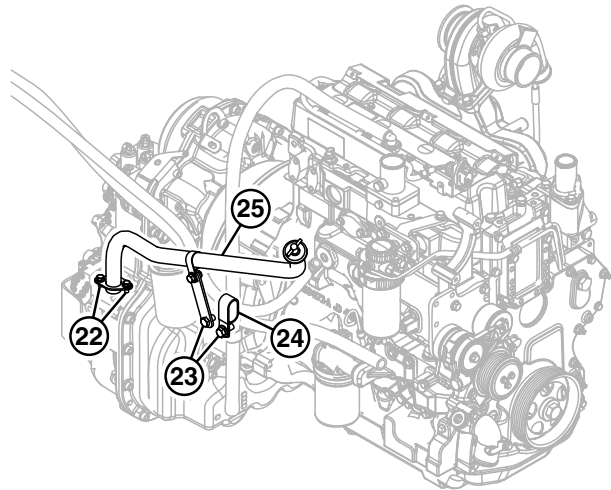

Transmission Oil Fill Tube

JD29379,000018E -19-20JUL12-4/13

TX1117644—UN—10JUL12

13. Install heater hoses (21).

21— Heater Hose (2 used)

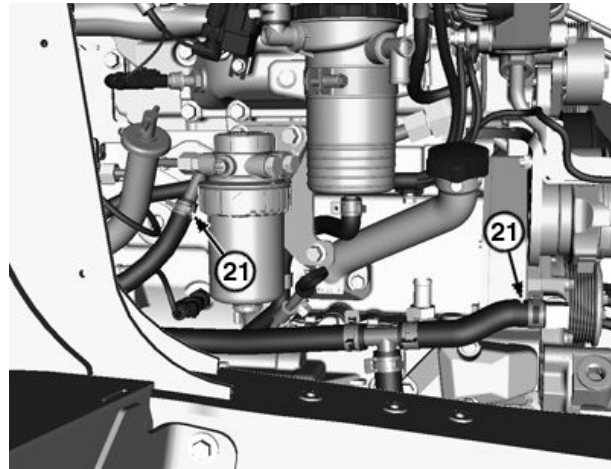

Heater Hoses

Continued on next page

JD29379,000018E -19-20JUL12-5/13

TX1115018A—UN—01JUN12

Group 0510 Cooling Systems

Fan Remove and Install

SPECIFICATIONS

Clutch Nut Torque	90—112 N·m 66—83 lb·ft
-------------------	---------------------------

1. Raise loader boom and install boom service lock. See [Loader Boom Service Lock](#). (Operator's Manual.)
2. Park and prepare machine for service. See [Park and Prepare for Service Safely](#). (Group 0001.)
3. Open engine hood to full open position.
4. Remove cap screws (1) and fan guard (2).
5. Remove cap screws (3) and remove grille housing support (4).

1— Cap Screw (3 used)
2— Fan Guard

3— Cap Screw (4 used)
4— Grille Housing Support

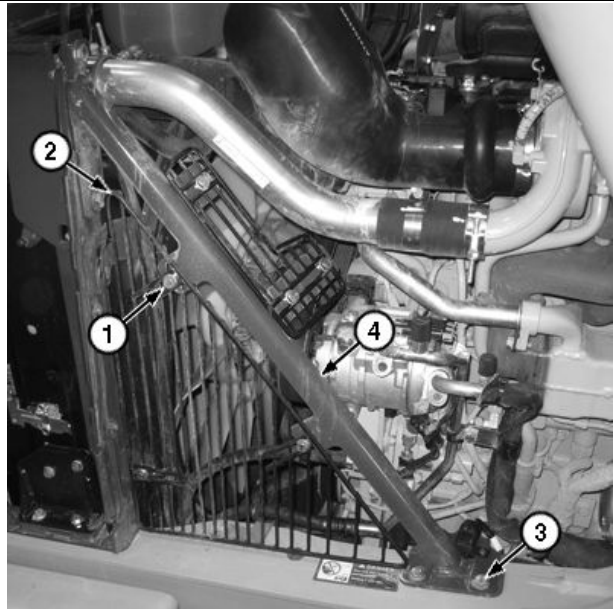

TX1114855A—UN—04JUN12

Fan Guard and Grille Housing Support

JD29379,0000191 -19-29SEP15-1/3

6. Loosen hose clamp (5) and disconnect charge air cooler tube (6).
7. Remove serpentine belt. See [Serpentine Belt Remove and Install](#). (Group 0510.)

5— Hose Clamp

6— Charge Air Cooler Tube

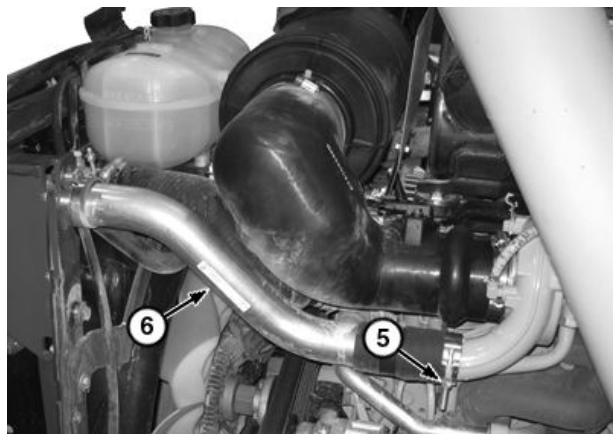

TX1114852A—UN—08JUN12

Charge Air Cooler Tube

Continued on next page

JD29379,0000191 -19-29SEP15-2/3

Cooling Systems

16. Tag and disconnect engine interface-to-horn and coolant level harness connector (X63).
17. Tag and disconnect hoses (21—24), loosen hose clamp (25), and disconnect lower radiator hose (26).

- | | |
|--------------------------------------|---|
| 21— Thermostat Housing Vent Hose | 25— Hose Clamp |
| 22— Thermal Bypass Valve Supply Hose | 26— Lower Radiator Hose |
| 23— Oil Cooler Supply Hose | X63— Engine Interface Harness-to-Horn and Coolant Level Harness Connector |
| 24— Coolant Pump Supply Hose | |

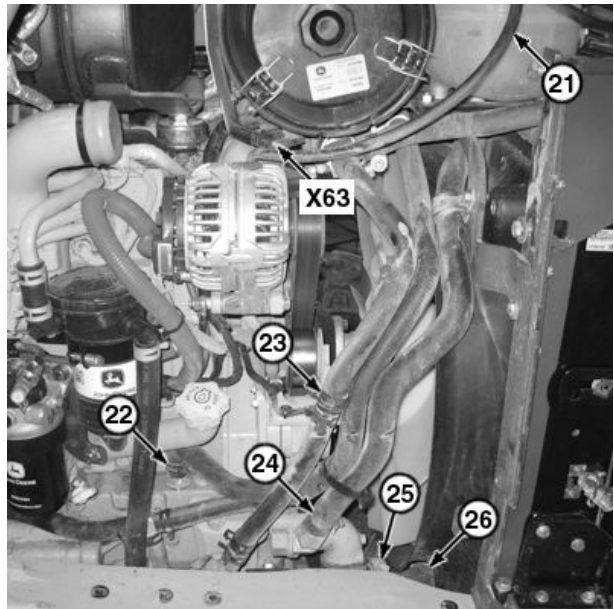

Lower Radiator Hose

TX1117479A —UN—09JUL12

Continued on next page

JD29379,00001C8 -19-07SEP12-5/6

Group 0560 External Fuel Supply Systems

TX1116506A —UN—25JUN12

Fuel Tank Remove and Install

SPECIFICATIONS

Fuel Tank Capacity (approximate)	155 L 41 gal.
Fuel Tank Weight (approximate)	56 kg 124 lb.

OTHER MATERIAL

7649 LOCTITE® Cure Primer
242 LOCTITE® Thread Lock and Sealer (medium strength)

1. Park and prepare machine for service. See Park and Prepare for Service Safely. (Group 0001.)

⚠ CAUTION: Prevent fire or explosion, handle fuel carefully. If engine is hot or running, DO NOT drain fuel tank. DO NOT smoke while draining fuel tank or working on fuel system.

NOTE: To ensure that all of fuel drains properly, use right stabilizer to lift right rear wheel off ground.

2. Remove drain screw (1) to drain fuel tank. See Handling and Storing Diesel Fuel. (Operator's Manual.)

LOCTITE is a trademark of Henkel Corporation

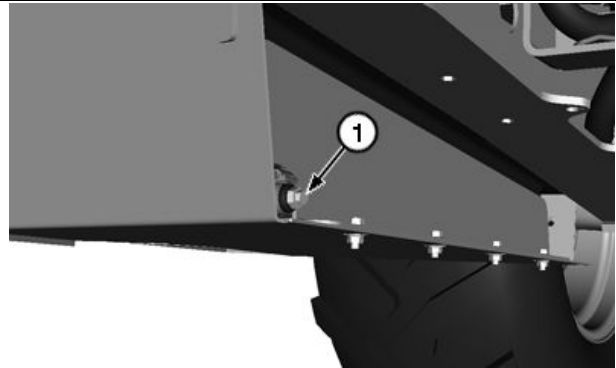

Fuel Tank Drain

1—Drain Screw

Specification

Fuel Tank—Capacity (approximate).....	155 L 41 gal.
---------------------------------------	------------------

JD29379,00001B4 -19-11JUL12-1/3

3. Tag and disconnect fuel tank vent hose (2), fuel return hose (3), and fuel supply hose (4). Close all openings using caps and plugs.
4. Disconnect electrical connector (5) from fuel level sensor (B8).

2— Fuel Tank Vent Hose
3— Fuel Return Hose
4— Fuel Supply Hose

5— Electrical Connector
B8—Fuel Level Sensor

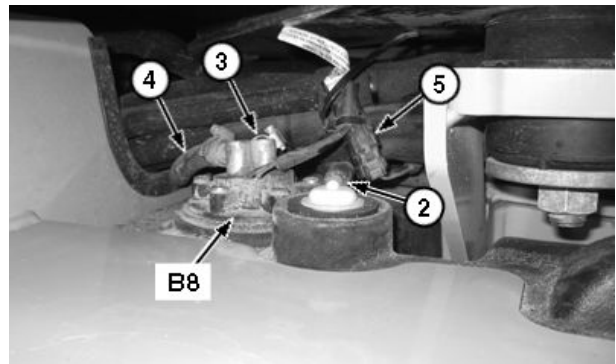

Fuel Level Sensor

Continued on next page

JD29379,00001B4 -19-11JUL12-2/3

TX1116506A —UN—25JUN12

Tilt Steering Wheel and Column Disassemble and Assemble

SPECIFICATIONS

Steering Wheel Nut Torque	48 N·m 35 lb.-ft.
---------------------------	----------------------

1. Remove nuts (1), cap screws (2), and transmission control lever (TCL) (3) from steering column (4).

1— Nut (2 used)
2— Cap Screw (2 used)

3— Transmission Control Lever (TCL)
4— Steering Column

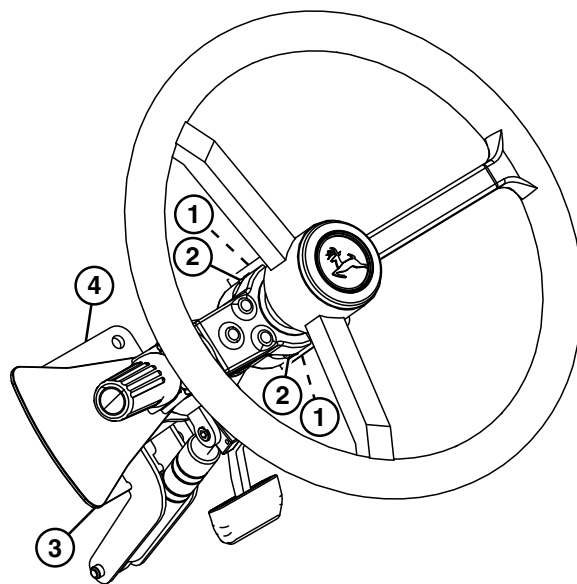

Transmission Control Lever (TCL) Removal

TX1118093—UN—16JUL12

DF89619,00B5224 -19-01AUG12-1/3

2. Remove cover (5) and O-ring (6) from steering wheel (7).
3. Remove nut (8), lock washer (9), and steering wheel.
4. Remove snap ring (10) and remove pin (11).
5. Remove cap screws (12) and cylinder assembly (13).

4— Steering Column
5— Cover
6— O-Ring
7— Steering Wheel
8— Nut

9— Lock Washer
10— Snap Ring
11— Pin
12— Cap Screw (2 used)
13— Cylinder Assembly

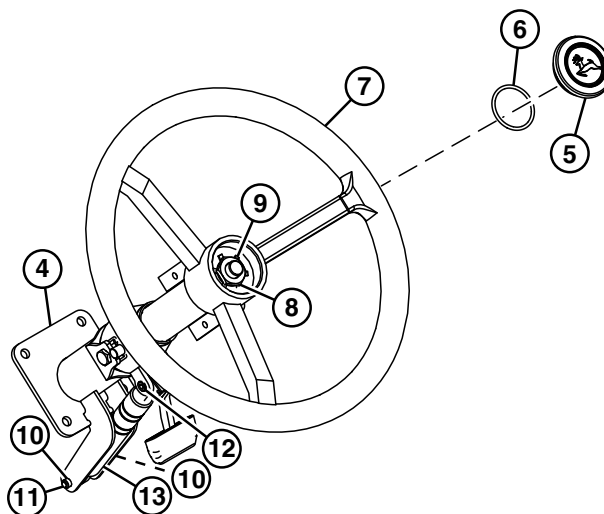

Cylinder and Steering Wheel Removal

TX1118095—UN—16JUL12

Continued on next page

DF89619,00B5224 -19-01AUG12-2/3

28. Install elbows (1, 3, and 5—7), priority valve supply check valve (2), adaptor (4), and stud (30) (if equipped). Tighten components to specification.

Specification

Elbow (1)—Torque.....	50 N·m
	37 lb·ft
Priority Valve Supply Check Valve (2)—Torque.....	73 N·m
	54 lb·ft
Elbow (3)—Torque.....	24 N·m
	212 lb·in
Adaptor (4)—Torque.....	73 N·m
	54 lb·ft
Elbow (5)—Torque.....	73 N·m
	54 lb·ft
Elbow (6)—Torque.....	21 N·m
	186 lb·in
Elbow (7)—Torque.....	73 N·m
	54 lb·ft
Stud (30) (if equipped)—Torque.....	75 N·m
	55 lb·ft

- | | |
|--------------------------------------|------------------------|
| 1— Elbow | 6— Elbow |
| 2— Priority Valve Supply Check Valve | 7— Elbow |
| 3— Elbow | 30— Stud (if equipped) |
| 4— Adaptor | 124— Steering Valve |
| 5— Elbow | |

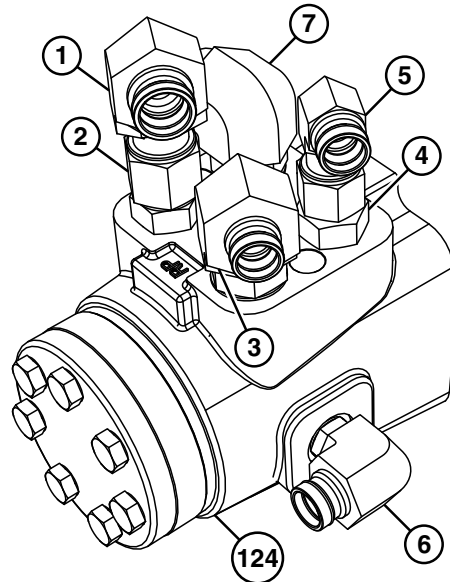

Steering Valve Fittings (S.N. —329327)

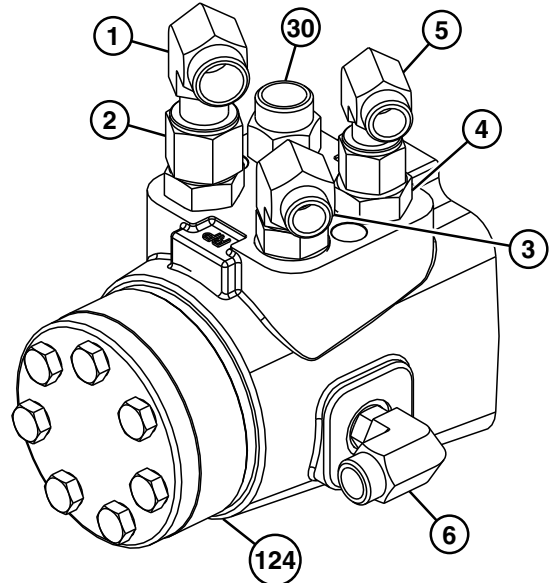

Steering Valve Fittings (S.N. 329328—)

TX1118488—UN—20JUL12

TX1257616—UN—01JUN18

BJ21193.000015B -19-12JUN18-9/9

Group 1011 Active Elements

Brake Disc and Pressure Plate Remove and Install

NOTE: Service brakes are part of the rear axle.

For brake disc and pressure plate remove and install, see Rear Axle Remove and Install, see Rear Axle Disassemble, and see Rear Axle Assemble. (Group 0250.)

JD29379.000016B -19-25JUN15-1/1

Group 1111 Active Elements

Park Brake Remove and Install

NOTE: Park brake is part of rear axle.

Remove and install park brake. See Rear Axle Remove and Install and see Park Brake Disassemble and Assemble. (Group 0250.)

JD29379,0000165 -19-05MAY12-1/1

Section 18 Operator's Station

Contents

	Page		Page
Group 1800—Removal and Installation			
Operator's Station Remove and Install	18-1800-1	Evaporator or Heater Core Remove and Install	18-1830-9
Group 1810—Operator Enclosure			
Front Window Wiper and Wiper Motor Remove and Install.....	18-1810-1	Expansion Valve Remove and Install	18-1830-10
Rear Window Wiper and Wiper Motor Remove and Install.....	18-1810-3	A/C Freeze Switch Remove and Install	18-1830-11
Rear Window and Frame Assembly Remove and Install.....	18-1810-4	Receiver-Dryer Remove and Install	18-1830-13
Front Console Remove and Install (S.N. —000470).....	18-1810-7	Condenser Remove and Install	18-1830-14
Fixed Window Remove and Install	18-1810-9	Compressor Remove and Install	18-1830-15
Non-Fixed Window Remove and Install	18-1810-10		
Non-Fixed Window Adjustment	18-1810-12		
Non-Fixed Window Latch Adjustment.....	18-1810-13		
Cab Door Hinges and Latch Adjustment.....	18-1810-14		
Headliner Remove and Install (S.N. —000470).....	18-1810-15		
Cab Roof Remove and Install.....	18-1810-16		
Group 1821—Seat and Seat Belt			
Seat Assembly Remove and Install	18-1821-1		
Air Suspension Seat Disassemble and Assemble.....	18-1821-1		
Seat Belt Disassemble and Assemble	18-1821-6		
Group 1830—Heating and Air Conditioning			
R134a Refrigerant Cautions and Proper Handling.....	18-1830-1		
R134a Compressor Oil Removal.....	18-1830-1		
R134a Component Oil Charge	18-1830-2		
Refrigerant Leakage Testing.....	18-1830-3		
Refrigerant Hoses and Tubing Inspection	18-1830-3		
R134a Refrigerant Recover, Recycle, and Charge Station Installation Procedure.....	18-1830-4		
Recover R134a System.....	18-1830-4		
Evacuate R134a System	18-1830-5		
Charge R134a System	18-1830-5		
Air Conditioning System Cleaning Procedures	18-1830-6		
Flush and Purge Air Conditioning System.....	18-1830-7		
Blower Mode Door Motor Remove and Install	18-1830-8		

Rear Window Wiper and Wiper Motor Remove and Install

SPECIFICATIONS	
Cap Screw (4) Torque	10 N·m 88 lb·in
Lock Nut (2) Torque	21 N·m 186 lb·in

1. Remove interior headliner. See Headliner Remove and Install. (Group 1810.)
2. Remove cab roof. See Cab Roof Remove and Install. (Group 1810.)
3. Pop up bottom portion of wiper arm (1) and remove lock nut (2).
4. Remove wiper arm and remove drive assembly (3).
5. Remove tie band (5) and electrical connector (6).
6. Remove cap screws (4).
7. Remove rear wiper motor (M14).
8. Inspect for worn or damaged parts and replace as necessary.
9. Install wiper motor and cap screws. Tighten to specification.

Specification

Cap Screw (4)—Torque..... 10 N·m
88 lb·in

10. Connect electrical connector and install tie band.

IMPORTANT: Prevent wiper arm damage resulting from slippage against wiper shaft spline (11) during operation. Metal chips and debris accumulated in the wiper shaft spline can cause the wiper shaft (10) to slip in the wiper

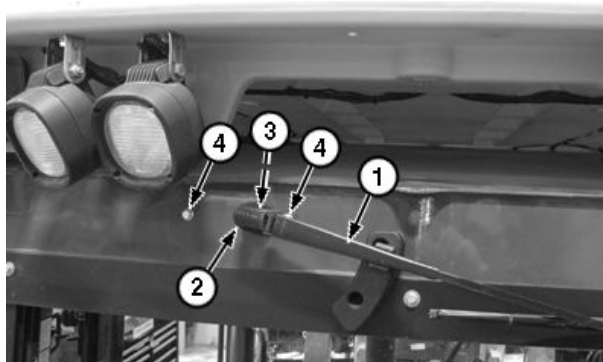

Rear Window Wiper

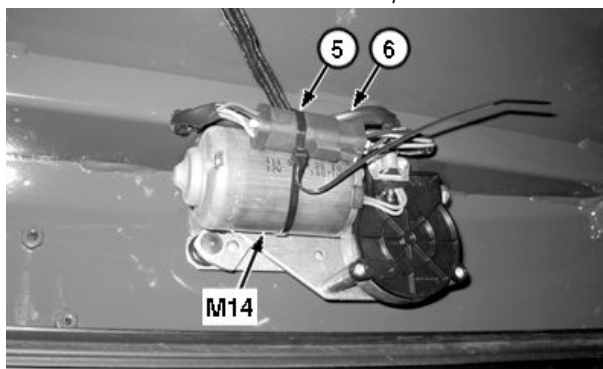

Rear Wiper Motor

- 1— Wiper Arm
- 2— Lock Nut
- 3— Drive Assembly
- 4— Cap Screw (2 used)
- 5— Tie Band
- 6— Electrical Connector
- M14— Rear Wiper Motor

arm. Clear wiper shaft spline and wiper arm mounting hole of metal chips or debris before installing wiper arm.

Continued on next page

SL78608,000061F -19-18JAN19-1/2

TX1116122A —UN—20JUN12

TX1116124A —UN—21JUN12

Operator Enclosure

2. Unlock window latches (1).
3. Loosen cap screws (2) and position window equally in door frame opening.
4. Tighten cap screws to specification.

Specification

Window-to-Hinge Cap
 Screw—Torque.....25 N·m
 221 lb·in.

5. Tighten window open lock knob (3) to allow knob to move freely.
6. Loosen window open lock knob mount in door window to adjust position to knob.
7. Tighten mount to specification.

Specification

Window Open Lock
 Mount—Torque.....2.93 N·m
 26 lb·in.

8. Lock window latches.

1— Window Latch (2 used) 3— Window Open Lock Knob
 2— Cap Screw (2 used)

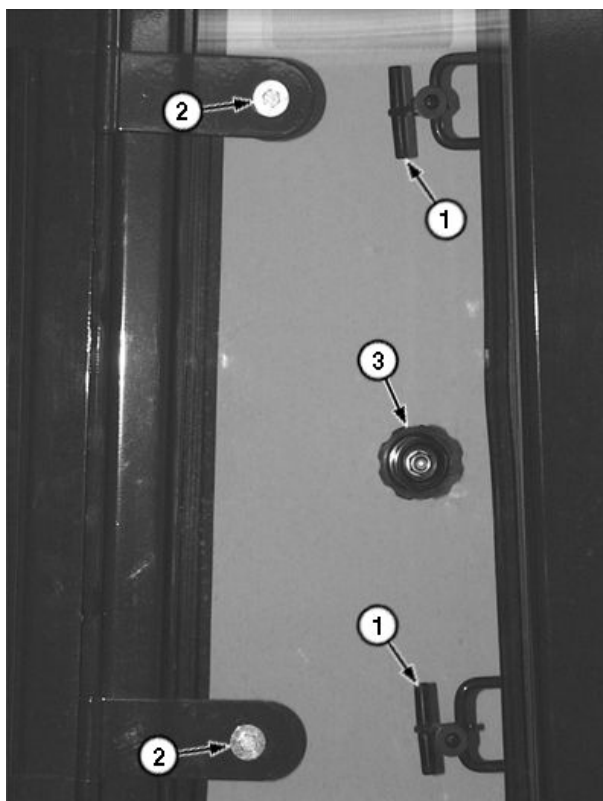

Side Window

TX1117900A —UN—12JUL12

SL78608,000095B -19-20AUG12-2/2

Non-Fixed Window Latch Adjustment

1. Close window and lock using latch (1).
2. Check for even compression of seal (2).
3. Open window. Bend striker (3) to obtain equal compression of seal.

1— Latch 3— Striker
 2— Seal

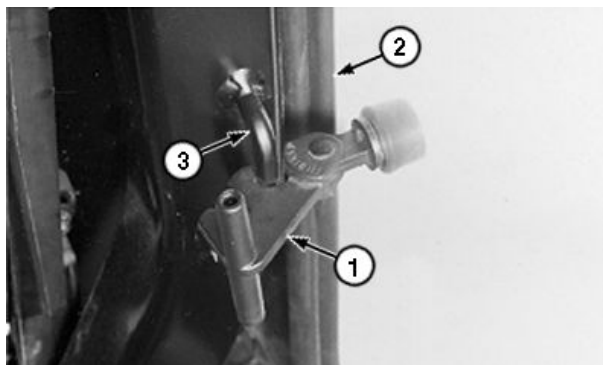

Window Latch

TX1114386A —UN—23MAY12

SL78608,0000623 -19-03JUL12-1/1

R134a Refrigerant Cautions and Proper Handling

⚠ CAUTION: DO NOT allow liquid refrigerant to contact eyes or skin. Liquid refrigerant will freeze eyes or skin on contact. Wear goggles, gloves and protective clothing.

If liquid refrigerant contacts eyes or skin, DO NOT rub area. Splash large amounts of COOL water on affected area. Go to a physician or hospital immediately for treatment.

DO NOT allow refrigerant to contact open flames or very hot surfaces such as electric welding arc, electric heating element and lighted smoking materials.

DO NOT heat refrigerant over 52 °C (125 °F) in a closed container. Heated refrigerant will develop high pressure, which can burst the container.

Keep refrigerant containers away from heat sources. Store refrigerant in a cool place.

DO NOT handle damp refrigerant container with your bare hands. Skin may freeze to container. Wear gloves.

If skin freezes to container, pour COOL water over container to free the skin. Go to a physician or hospital immediately for treatment.

IMPORTANT: To meet government standards relating to the use of refrigerants, R134a is used in the air conditioning system. Because it does not contain chlorine, R134a is not detrimental to the ozone in the atmosphere. However, it is illegal to discharge any refrigerant into the atmosphere. It must be recovered using the appropriate recovery stations.

Use correct refrigerant recovery/recycling and charging stations. Never mix refrigerants, hoses, fittings, components or refrigerant oils.

IMPORTANT: Use only John Deere approved R134a refrigerant products. Mixing of products not compatible will cause system damage and contaminate recovery/recycling and charging station equipment. Care must be taken to identify and use equipment, refrigerant oil and refrigerant designed only for R134a refrigerant systems. Refrigerant should be tested for type and purity before recovery, recycling or charging of system. JT02167A Prism Pro Refrigerant Identification Instrument should be used before any testing or repair to system is performed.

SL78608,0000935 -19-01APR15-1/2

Prism Pro Refrigerant Identification Instrument.. JT02167A

To safely identify type and check purity of refrigerant prior to recovery, recycling and recharging of A/C systems.

SL78608,0000935 -19-01APR15-2/2

R134a Compressor Oil Removal

1. Park and prepare machine for service. See Park and Prepare for Service Safely. (Group 0001.)
2. Remove compressor from machine. See Compressor Remove and Install. (Group 1830.)
3. Drain oil into graduated container while rotating compressor shaft.
4. Record measured oil and discard oil properly.
5. Install new oil. See R134a Component Oil Charge. (Group 1830.)
6. Install compressor. See Compressor Remove and Install. (Group 1830.)

SL78608,0000936 -19-04JUN12-1/1

9. Disconnect and tag refrigerant hoses (10). Close all openings using caps and plugs.
10. Remove cap screw (11) and expansion valve (12).
11. Repair or replace as necessary.
12. Install expansion valve (12) and cap screw (11). Tighten cap screw (11) to specification.

Specification

Cap Screw—Torque..... 5.2—6.2 N·m
46—55 lb·in.

13. Install refrigerant hoses.
14. Install lower console cover and stabilizer cover.
15. Install cap screws (7 and 6).
16. Install air filter grille to lower console cover.
17. Install floor mats.
18. Install new receiver-dryer. [See Receiver-Dryer Remove and Install.](#) (Group 1830.)
19. Evacuate and charge air conditioning system. [See Evacuate R134a System](#) and [see Charge R134a System.](#) (Group 1830.)

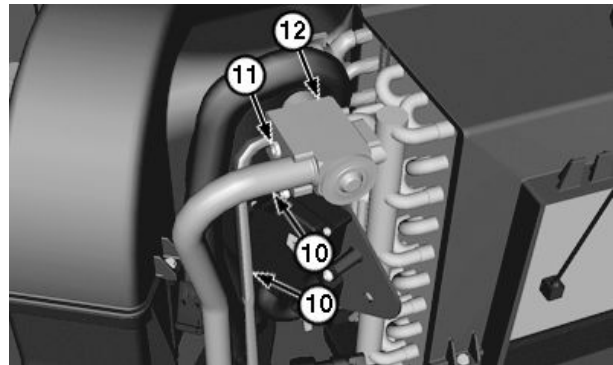

Expansion Valve

10— Refrigerant Hose (2 used) 12— Expansion Valve
11— Cap Screw

20. Connect negative (-) battery cable or turn battery disconnect switch to ON position. [See Battery Disconnect—If Equipped.](#) (Operator's Manual.)

SK44377,00002B3 -19-01DEC14-2/2

TX1121487A—UN—28AUG12

Air Conditioner Freeze Control Switch Remove and Install

1. Park and prepare machine for service. [See Park and Prepare for Service Safely.](#) (Group 0001.)
2. Remove cap screws (1), washers (2), and cap screws (3).
3. Remove stabilizer linkage access cover (4).

1— Cap Screw (3 used)
2— Washer (3 used)

3— Cap Screw (2 used)
4— Stabilizer Linkage Access Cover

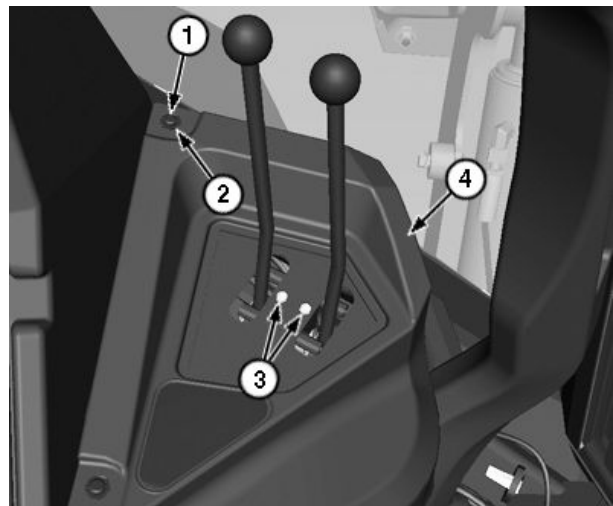

Stabilizer Linkage Access Cover

Continued on next page

SL78608,0000638 -19-11SEP12-1/4

TX1115502A—UN—13JUN12

Battery Box Remove and Install

SPECIFICATIONS	
Battery Weight (approximate)	29 kg 64 lb.
Battery Box Weight (approximate)	44 kg 96 lb.

Dual Batteries

1. Park machine and prepare for service. See Park and Prepare for Service Safely. (Group 0001.)
2. Raise loader boom and install service lock. See Loader Boom Service Lock. (Operator's Manual.)
3. Remove cap screws (1) and washers (2).
4. Remove tool box (3).

1— Cap Screw (3 used) 3— Tool Box
2— Washer (3 used)

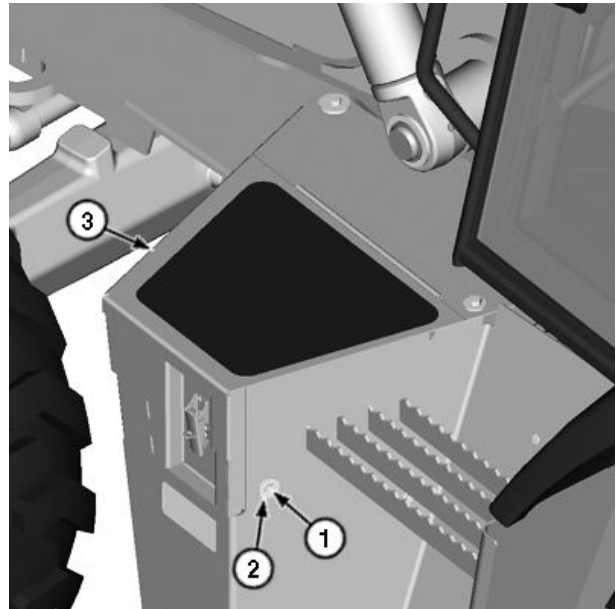

Tool Box

TX1113397A —UN—05JUN12

JD29379,0000193 -19-07JUN12-1/6

5. Disconnect negative (-) battery cable (4) first, then disconnect positive (+) battery cable (5).
6. Remove flange nut (6).
7. Remove nuts (7) and washers (8).
8. Remove brackets (9).

⚠ CAUTION: Prevent possible crushing injury from heavy component. Use appropriate lifting device.

9. Remove battery 1 and battery 2 (G1 and G2) using appropriate lifting device.

Specification

Battery—Weight
(approximate)..... 29 kg
64 lb.

4— Negative (-) Battery Cable 8— Washer (4 used)
5— Positive (+) Battery Cable 9— Bracket (2 used)
6— Flange Nut G1—Battery 1
7— Nut (4 used) G2—Battery 2

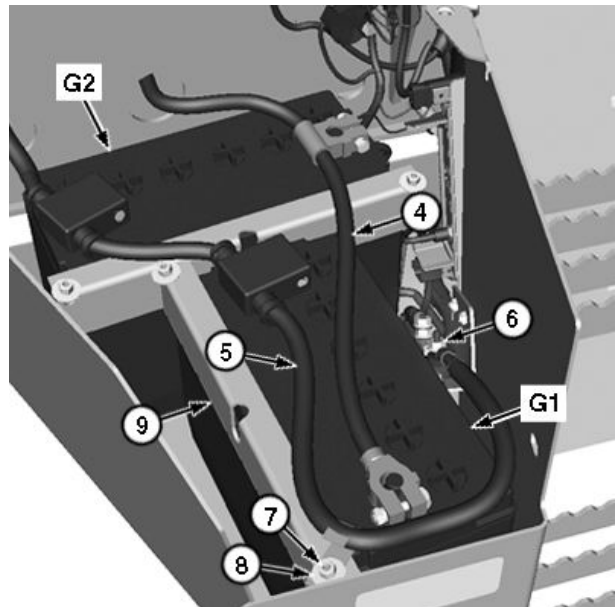

Batteries

TX1113414A —UN—04JUN12

Continued on next page

JD29379,0000193 -19-07JUN12-2/6

Group 2004 Horn and Warning Devices

Horn Remove and Install

1. Park and prepare machine for service. See Park and Prepare for Service Safely. (Group 0001.)
2. Raise loader boom and install boom service lock.
3. Open engine hood to full open position. See Opening and Closing Engine Hood. (Operator's Manual.)

NOTE: Horn is located on left side above radiator in engine compartment.

4. Disconnect electrical connectors (1).
5. Remove cap screw (2) and horn (H40).
6. Repair or replace parts as necessary.
7. Install horn and cap screw.
8. Connect electrical connectors.
9. Close engine hood. See Opening and Closing Engine Hood. (Operator's Manual.)
10. Remove boom service lock and lower loader boom to ground.

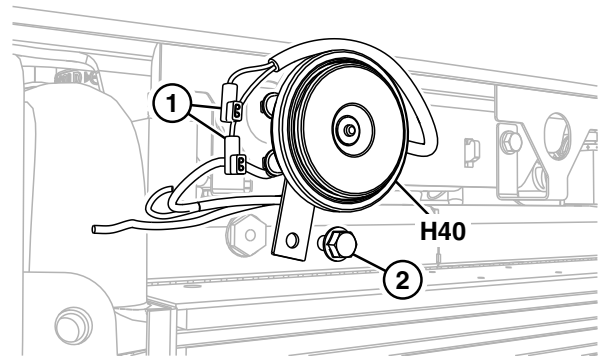

Horn Location

- 1— Electrical Connector (2 used)
2— Cap Screw
- H40— Horn

TX1113869—UN—02JUL12

SL78608,000095C -19-12JUL12-1/1

Backup Alarm Remove and Install

NOTE: Backup alarm is located inside main frame on right-rear side.

1. Park and prepare machine for service. See Park and Prepare for Service Safely. (Group 0001.)
2. Remove lock nuts (1) and cap screws (2).
3. Disconnect electrical connectors (3).
4. Remove backup alarm (H3).
5. Repair or replace as necessary.
6. Install backup alarm, cap screws, and lock nuts.
7. Connect electrical connectors.

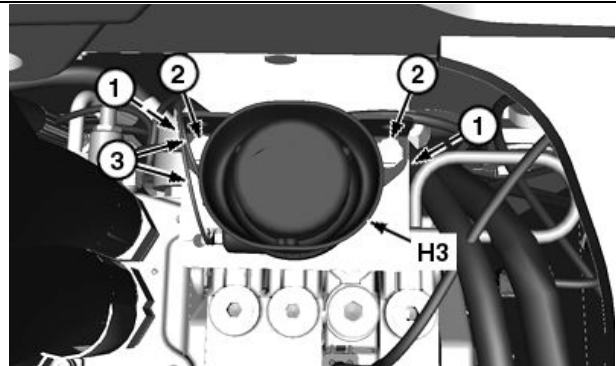

Backup Alarm

- 1— Lock Nut (2 used)
2— Cap Screw (2 used)
- 3— Electrical Connector (2 used)
H3— Backup Alarm

TX1116930A—UN—29JUN12

SL78608,00008D6 -19-24AUG12-1/1

Hydraulic Pump Control Disassemble and Assemble

NOTE: Pump control is serviced as complete assembly or a seal kit only.

IMPORTANT: When removing adjusting screws and O-rings make note to retain current settings.

1. Remove complete adjustment screw assemblies by removing fittings (4 and 23) with all adjusting parts in place. Replace O-ring (5 and 21). Install adjustment assemblies in housing. Tighten in housing (14) port.
2. Remove adjustment covers (1) for load sense and high pressure cut off screws (3).
3. Remove lock nuts (22) and O-rings (2) being careful not to lose current settings. Replace O-rings.
4. Install lock nuts, O-rings and adjustment covers.
5. Install control on hydraulic pump housing.

1— Cap (adjustment screw)	13— Plug (2 used)
2— O-rings (4 used)	14— Control Housing
3— Adjustment Screw (2 used)	15— Spool (high pressure cut-off)
4— Fitting	16— Guide
5— O-ring	17— Spring
6— Spring	18— Spring
7— Spring	19— Spacer
8— Guide	20— Spacer
9— Spool (load sense)	21— O-ring
10— Plug	22— Hex Nut (2 used)
11— Plug	23— Fitting
12— Cap Screw (4 used)	

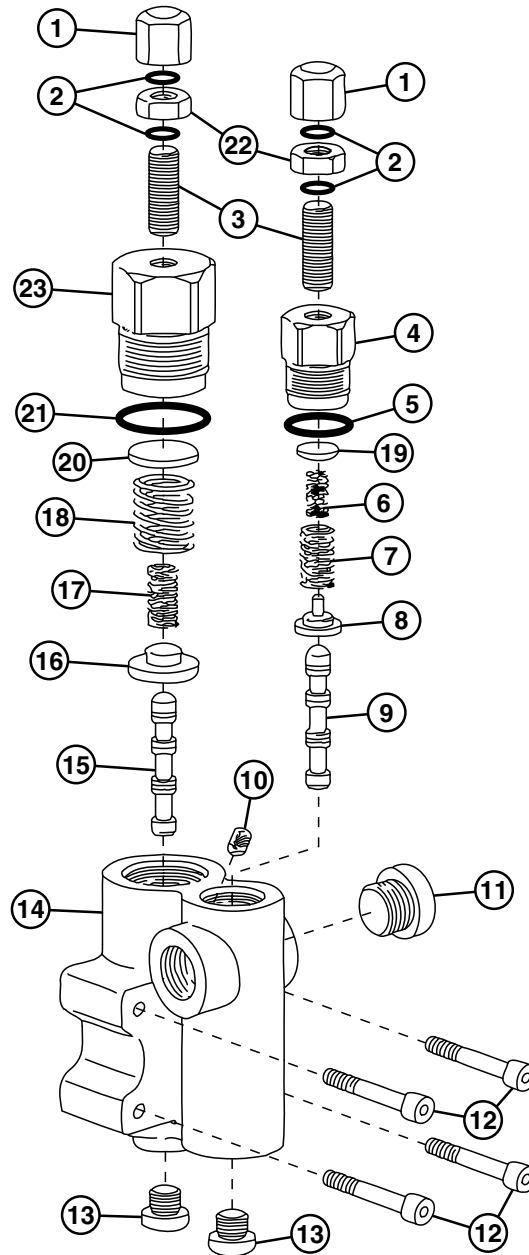

Pump Control Exploded View

DF89619,00B51FA -19-31MAY12-1/1

T211883 —UN—23JUN05

Hydraulic System

7. Rotate hydraulic oil filter (118) counterclockwise to remove.
8. Tag and disconnect hoses (3 and 4). Close all openings with caps or plugs.
9. Disconnect hydraulic oil filter-to-hydraulic oil reservoir hose (5). Close all openings using caps and plugs.

IMPORTANT: Hydraulic filter restriction switch (B12) connector is hidden. To prevent possible damage to wiring and switch, support filter assembly when removing cap screws.

10. Support hydraulic filter assembly and remove cap screws (6).
11. Disconnect electrical connector from hydraulic oil filter restriction switch (B12) and remove hydraulic filter assembly.
12. Inspect and replace parts as necessary.
13. Connect electrical connector to hydraulic oil filter restriction switch.
14. Install hydraulic oil filter assembly and cap screws.
15. Connect hoses.
16. Install floor access panel and cap screws.
17. Install front floor mat.
18. Apply clean hydraulic oil to filter seal. Turn hydraulic oil filter clockwise until seal touches base and tighten additional 3/4 turn.
19. Fill hydraulic oil reservoir or remove vacuum. See Change Hydraulic Reservoir Oil. (Operator's Manual.)
20. Connect battery negative (-) ground cable or turn battery disconnect switch (if equipped) to the ON position. See Battery Disconnect—If Equipped. (Operator's Manual.)
21. Start engine and check for leaks.

3— Electrohydraulic Spool Valve-to-Hydraulic Oil Filter Hose
 4— Hydraulic Oil Filter-to-Hydraulic Oil Cooler Hose
 5— Hydraulic Oil Filter-to-Hydraulic Oil Reservoir Hose

6— Cap Screw (4 used)
 118— Hydraulic Oil Filter
 B12— Hydraulic Oil Filter Restriction Switch

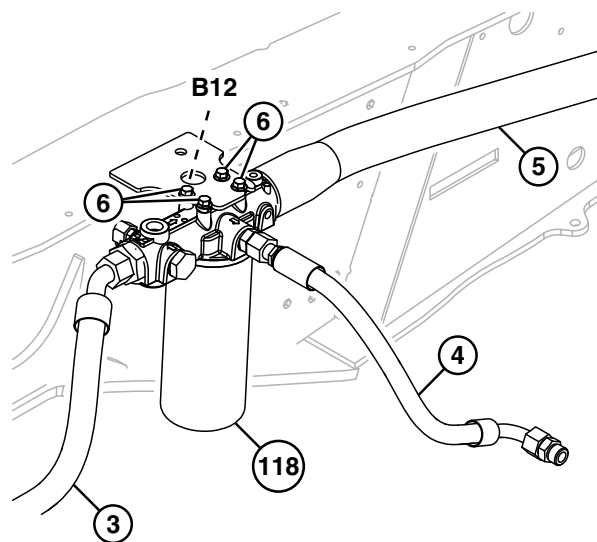

Hydraulic Filter Assembly

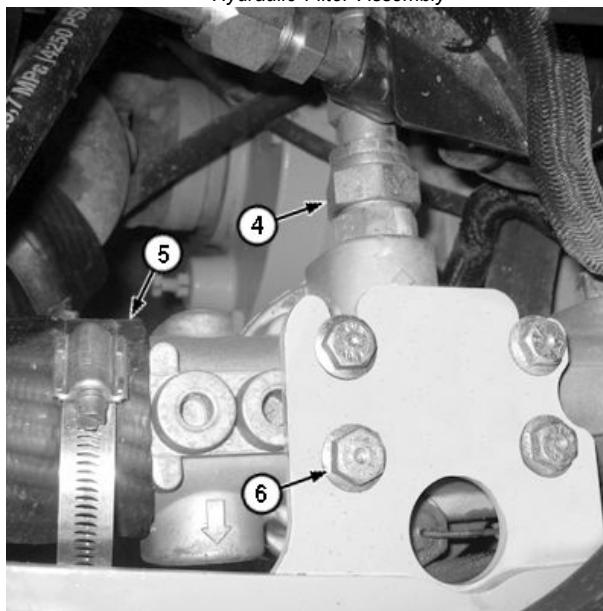

Hydraulic Filter Assembly (view from access panel)

DF89619,00B51DE -19-11JUN12-3/3

TX1114139—UN—06JUN12

TX1114140A—UN—06JUN12

Loader Bucket Cylinder Linkage Remove and Install

SPECIFICATIONS

Loader Bucket Cylinder Weight (approximate)	45 kg 100 lb
---	-----------------

SERVICE EQUIPMENT AND TOOLS

D01045AA Bushing, Bearing, and Seal Driver Set

1. Park and prepare machine for service. See Park and Prepare for Service Safely. (Group 0001.)
2. Lower all equipment to ground and stop engine.

CAUTION: To avoid injury from escaping fluid under pressure, stop engine and relieve pressure in system before disconnecting or connecting hydraulic or other lines. Tighten all connections before applying pressure.

3. Release pressure in hydraulic system. See Hydraulic Circuit Pressure Release. (Group 9025-25.)
4. If equipped, remove snap ring (2) and self leveling rod (1) from bucket linkage.

CAUTION: Prevent possible injury from falling linkage. Bucket cylinder and links will fall when pins are removed. Support or block linkage and cylinder before removing pins.

5. Support or block linkage from falling when disconnecting linkage.
6. Attach bucket cylinder to appropriate lifting device.

Specification

Loader Bucket Cylinder—Weight (approximate).....	45 kg 100 lb
--	-----------------

7. Remove snap rings (4), washers (5), and bucket links (3 and 9) from machine
8. Inspect links. Repair or replace as needed.
9. Clean and inspect bushings and cylinder trunnions.

NOTE: If fit of bushings to cylinder trunnions is still tight, then reuse the bushings. If fit is not tight or bushings are damaged, replace as needed.

10. Remove bushings using D01045AA Bushing, Bearing, and Seal Driver Set.
11. Apply multipurpose grease to inside of bushings and cylinder trunnions before assembly

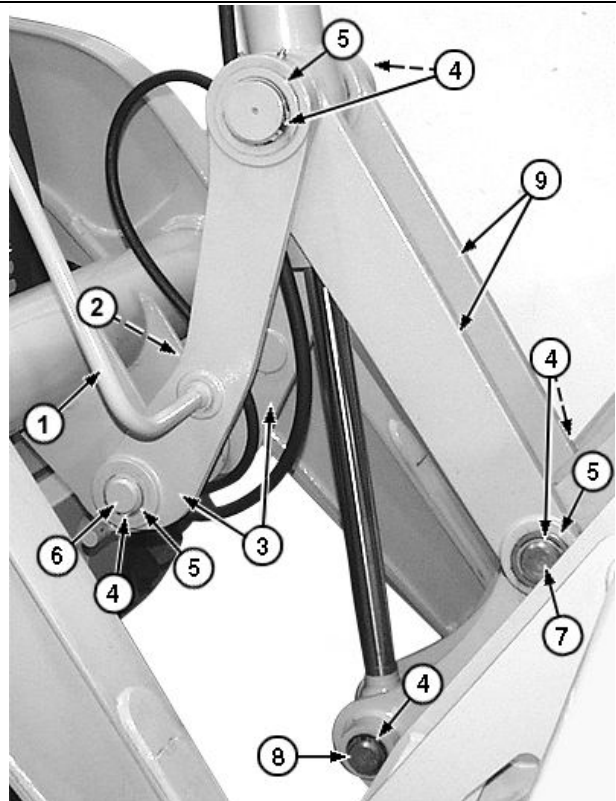

Loader Bucket Cylinder Linkage

- | | |
|------------------------|------------------------|
| 1—Self Leveling Rod | 6—Pin |
| 2—Snap Ring | 7—Pin |
| 3—Bucket Link (2 used) | 8—Pin |
| 4—Snap Ring (8 used) | 9—Bucket Link (2 used) |
| 5—Washer (as needed) | |

IMPORTANT: Do not use a graphite-based grease on the synthetic bushings when assembling. Graphite deteriorates synthetic bushings. Excessive use of grease to joint attracts dirt, sand that causes excessive wear to bushings.

12. Install bucket links (9) to bucket and bucket cylinder with pin (7), washers (5), and snap rings (4)
13. Install bucket links (3) to loader boom and bucket cylinder with pin (6), washers (5), and snap rings (4).
14. Align bucket links with cylinder and attach links to cylinder using washers and snap rings. Use shims as required to reduce looseness on bucket links and bucket links to cylinder.
15. Install self leveling rod with snap ring.

XJ1257193A—UN—22MAY18

SL78608,0000652 -19-23MAY18-1/1

Ride Control Valve Solenoid Disassemble and Assemble

SPECIFICATIONS	
Solenoid Valve Spool Torque	41 N·m 30 lb.-ft.
Ride Control Solenoid Nut Torque	5 N·m 48 lb.-in.

NOTE: Ride control valve solenoids can be serviced with ride control valve installed on machine.

NOTE: To remove ride control valve, see Ride Control Valve Remove and Install. (Group 3160.)

1. Remove nuts (4).
2. Remove ride control solenoids (Y50 and Y51) from solenoid valve spools (3).
3. Remove solenoid valve spools from ride control valve (204).
4. Remove O-rings (1 and 2).
5. Inspect and clean all orifices (5).

IMPORTANT: Prevent O-ring or component damage. Apply clean hydraulic oil to all internal parts before assembly and petroleum jelly to O-rings before installation.

6. Apply petroleum jelly to new O-rings. Install new O-rings.
7. Apply clean hydraulic oil to all internal parts. Install solenoid valve spool in ride control valve. Tighten to specification.

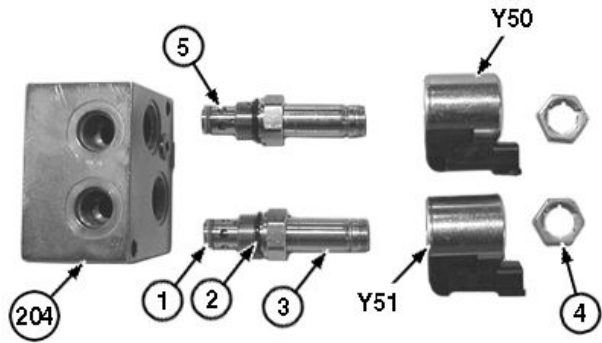

Ride Control Valve Solenoid

- 1— O-Ring (2 used)
- 2— O-Ring (2 used)
- 3— Solenoid Valve Spool (2 used)
- 4— Nut (2 used)
- 5— Orifice (2 used)
- 204— Ride Control Valve
- Y50— Ride Control Solenoid 1
- Y51— Ride Control Solenoid 2

Specification

Solenoid Valve	
Spool—Torque.....	41 N·m 30 lb.-ft.

8. Install ride control solenoids and nuts. Tighten to specification.

Specification

Ride Control Solenoid	
Nut—Torque.....	5 N·m 48 lb.-in.

9. To install ride control valve (if removed), see Ride Control Valve Remove and Install. (Group 3160.)

DI77374,0000E98 -19-30AUG12-1/1

TX1116137A —UN—23AUG12

Backhoe Boom Lock Control Lever and Linkage Remove and Install

Manual Controls

1. Park and prepare machine for service. See Park and Prepare for Service Safely. (Group 0001.)
2. Remove rear floor mat.
3. Remove cap screws (1) and console cover (2).

1— Cap Screw (4 used)

2— Console Cover

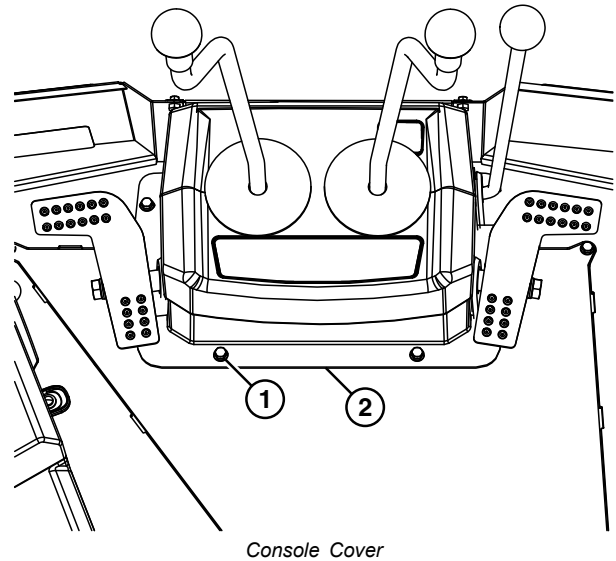

Continued on next page

DF89619.00B5257 -19-07SEP12-1/4

Swing Frame Remove and Install

SPECIFICATIONS	
Swing Frame (310K-410K) Weight (approximate)	129 kg 284 lb.
Swing Frame (710K) Weight (approximate)	298 kg 657 lb.

1. Park and prepare machine for service. See Park and Prepare for Service Safely. (Group 0001.)
2. Remove dipperstick. See Dipperstick Remove and Install. (Group 3340.)
3. Remove boom. See Backhoe Boom Remove and Install. (Group 3340.)

CAUTION: Prevent possible crushing injury from heavy component. Use appropriate lifting device.

4. Connect swing frame (1) to hoist using a lift strap.

Specification

Swing Frame (310K-410K)—Weight (approximate).....	129 kg 284 lb.
---	-------------------

Specification

Swing Frame (710K)—Weight (approximate).....	298 kg 657 lb.
--	-------------------

5. Remove boom lock rod (2) from boom lock hook (3).
6. Remove cap screws (4) and washers (5).
7. Remove hose guard (6) from swing frame.
8. Remove swing cylinder locking snap ring and rod (7) from swing frame.
9. Remove pin (8) from swing frame.
10. Remove upper pivot locking cap screw (9) and lock nut (10) from the swing frame.
11. Remove lower pivot locking cap screw (11) and lock nut (10) from the swing frame.
12. Remove upper pivot pin (12), thrust washer (13), and lower shim (14) from both the top and lower mainframe pivot boss of the swing frame.
13. Remove swing frame.
14. Repair or replace as necessary.

NOTE: Weight of backhoe is supported at the lower pivot. There must be clearance between upper main frame pivot boss and the ears of the swing frame.

15. Install thrust washer on top of lower mainframe pivot boss.

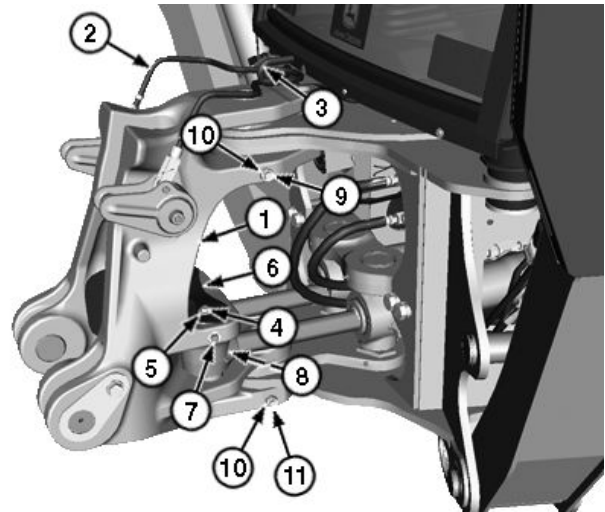

Swing Frame

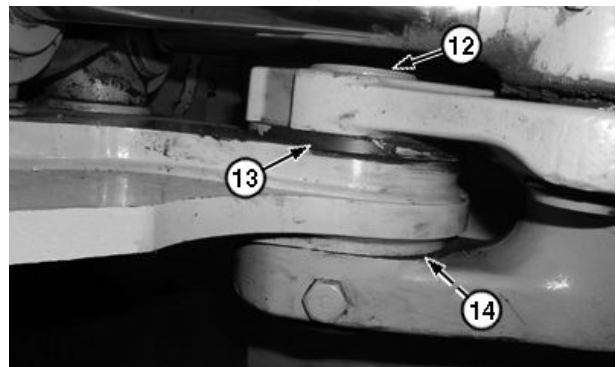

Lower Pivot Joint

- | | |
|---|-----------------------------------|
| 1— Swing Frame | 8— Pin (2 used) |
| 2— Boom Lock Rod | 9— Upper Pivot Locking Cap Screw |
| 3— Boom Lock Hook | 10— Lock Nut (2 used) |
| 4— Cap screw (2 used) | 11— Lower Pivot Locking Cap Screw |
| 5— Washer (2 used) | 12— Upper Pivot Pin |
| 6— Hose Guard | 13— Thrust Washer |
| 7— Swing Cylinder Locking Snap Ring and Rod | 14— Lower Shim |

NOTE: Install swing frame pins so that cross-drilled holes align with holes in swing frame to ease hardware installation.

16. Position swing frame and install upper pivot pin. Secure in position with upper pivot locking cap screw and nut.
17. Align thrust washer with pin bore. Install lower pivot pin and secure in position with lower pivot locking cap screw and nut.
18. Align swing cylinders and install pins from the bottom. Top of pins should be even with casting. Secure in position with swing cylinder locking snap ring and rod.
19. Install hose guard, washers, and cap screws.

Continued on next page

SL78608,0000675 -19-03JUL12-1/2

TX1116033A —UN—03JUL12

TX1114917A —UN—20JUN12

5. Remove hose clamp (1) from backhoe bucket cylinder (163).
6. Tag and disconnect hydraulic hoses from backhoe bucket cylinder. Close all openings using caps and plugs.

CAUTION: Prevent possible crushing injury from heavy component. Use appropriate lifting device.

7. Install appropriate lifting device to backhoe bucket cylinder using lifting straps.

Backhoe Bucket Cylinder—Specification

310K—Weight (approximate).....	45 kg 99 lb.
310SK, 310SK TMC, 315SK, 325K, 325SK—Weight (approximate).....	59 kg 130 lb.
410K, 410K TMC—Weight (approximate).....	66 kg 145 lb.
710K—Weight (approximate).....	105 kg 230 lb.

8. Remove snap ring (2) and washer (3) from rod end pin (4).
9. Remove rod end pin.
10. Remove snap rings and washers from head end pin (5).
11. Remove head end pin.
12. Remove backhoe bucket cylinder.

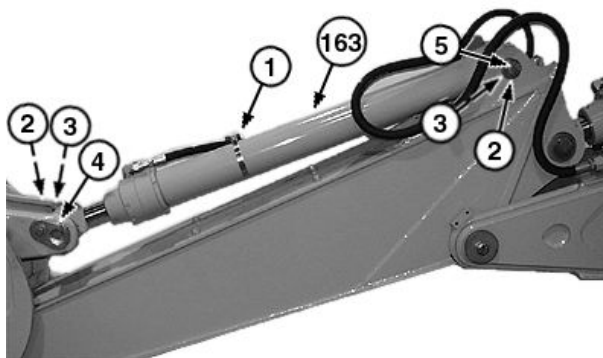

Backhoe Bucket Cylinder Removal

- | | |
|----------------------|-----------------------------|
| 1—Hose Clamp | 4—Rod End Pin |
| 2—Snap Ring (3 used) | 5—Head End Pin |
| 3—Washer (3 used) | 163—Backhoe Bucket Cylinder |

13. Repair or replace backhoe bucket cylinder as necessary. See Backhoe Bucket Cylinder Disassemble and Assemble. (Group 3360.)
14. Install backhoe bucket cylinder.
15. Install pins at head and rod ends of backhoe bucket cylinder.
16. Install washers and snap rings.
17. Connect backhoe bucket cylinder hydraulic hoses and install hose clamp.
18. Turn battery disconnect switch to ON or connect battery negative (-) cables.
19. Operate backhoe to check for leaks and proper bucket cylinder operation.

PN36905.0000010 -19-17FEB13-2/2

TX1114996A—UN—09JUL12

Backhoe Bucket Cylinder Disassemble and Assemble

For backhoe bucket cylinder repair information, see Cylinder Identification. (CTM120519.)

PN36905.0000014 -19-21APR14-1/1

Hydraulic System

14. Remove cap screws (5) and EH spool valve shield (6).

5— Cap Screw (3 used)

6— EH Spool Valve Shield

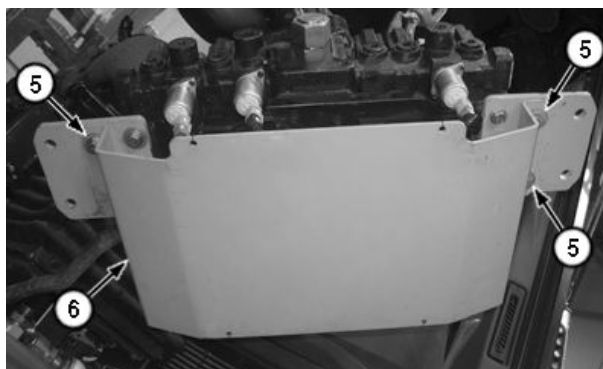

Spool Valve Shield

TX1114056A —UN—07JUN12

DF89619,00B51DD -19-22JUN12-5/6

15. Loosen cap screws (7) and free harness support bracket (8).
16. Tag and disconnect all electrical connectors on bottom side of EH spool valve.
17. Remove cap screws (7 and 9) and mounting brackets (10) from EH spool valve.
18. Repair or replace EH spool valve, if necessary. See [Electrohydraulic Spool Valve Disassemble and Assemble](#). (Group 3360.)
19. Install mounting brackets and cap screws.
20. Connect all electrical connectors on bottom side of EH spool valve.
21. Install EH spool valve shield and cap screws.
22. Install EH spool valve and install cap screws.
23. Connect all EH spool valve hydraulic hoses.
24. Connect electrical connector to load sense generation solenoid.
25. Install rear floor access plate.
26. Install backhoe boom lock control lever and linkage. See [Backhoe Boom Lock Control Lever and Linkage Remove and Install](#). (Group 3315.)
27. Install rear windows. See [Non-Fixed Window Remove and Install](#). (Group 1810.)
28. Install rear floor mat.

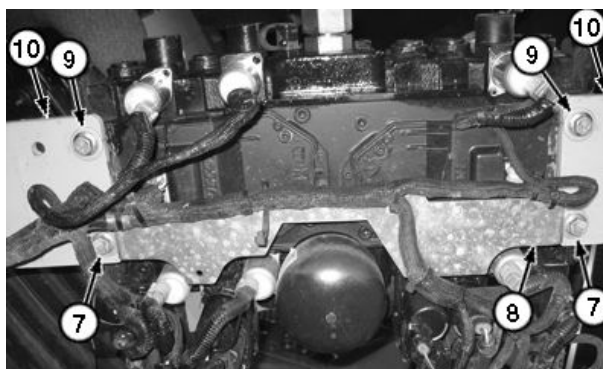

Chassis Harness

7— Cap Screw (2 used)

8— Harness Support Bracket

9— Cap Screw (2 used)

10— Mounting Bracket (2 used)

29. Fill hydraulic reservoir or remove vacuum. See [Change Hydraulic Reservoir Oil](#). (Operator's Manual.)
30. Connect battery negative (-) ground cable or turn battery disconnect switch (if equipped) to the ON position. See [Battery Disconnect—If Equipped](#). (Operator's Manual.)
31. Start machine and check calibration of EH spool valve. See [Electrohydraulic Spool Valve Calibration](#). (Group 9015-20.)

TX1114056A —UN—07JUN12

DF89619,00B51DD -19-22JUN12-6/6

Hydraulic System

20. Install pressure relief valves and O-rings (23). Tighten pressure relief valves to specification.

Specification

Pressure Relief Valve
(22)—Torque..... 30—38 N·m
22—28 lb.-ft.

JR05199,00008CD -19-13AUG12-3/3

Hydraulic System

6. Remove pressure regulating valve gauge port quick disconnect (15).
7. Clean and inspect parts for contamination, wear, or damage. Replace as necessary.
8. Install pressure regulating valve gauge port quick disconnect. Tighten to specification.

Specification

Pressure Regulating Valve Gauge Port Quick Disconnect—Torque.....	21—27 N·m 192—240 lb.-in.
---	------------------------------

9. Install poppet, spring (9), O-ring (7), and check valve. Tighten check valve to specification.

Specification

Check Valve—Torque.....	12—15 N·m 108—132 lb.-in.
-------------------------	------------------------------

10. Install hydraulic pressure valve. Tighten to specification.

Specification

Hydraulic Pressure Valve—Torque.....	37—43 N·m 22—28 lb.-ft.
--------------------------------------	----------------------------

11. Install load sense generation solenoid. Tighten to specification.

Specification

Electrohydraulic Proportional Valve—Torque (cartridge).....	21—27 N·m 192—240 lb.-in.
---	------------------------------

12. Install flow control hydraulic valve. Tighten to specification.

Specification

Flow Control Hydraulic Valve—Torque.....	40—50 N·m 29—37 lb.-ft.
--	----------------------------

13. Install spool assemblies, snap rings, springs (4), O-rings (3), and fitting plugs (2 and 5). Tighten fitting plugs to specification.

Specification

Fitting Plug (2 and 5)—Torque.....	21—27 N·m 192—240 lb.-in.
------------------------------------	------------------------------

JR05199,00008D1 -19-09AUG12-3/2

Electrohydraulic Distributed Valve Remove and Install

SPECIFICATIONS

Electrohydraulic Distributed Valve Weight	23 kg 50 lb.
Electrohydraulic Distributed Valve Torque	25 N·m 220 lb.-in.

1. Park and prepare machine for service. See Park and Prepare for Service Safely. (Group 0001.)
2. Place the transmission control lever (TCL) in neutral and set the park brake.
3. Extend backhoe and lower attachment to ground.
4. Stop engine and relieve hydraulic system pressure. See Hydraulic Circuit Pressure Release. (Group 9025-25.)
5. Remove cap screws (1), washers (2) and electrohydraulic (EH) distributed valve cover (3).

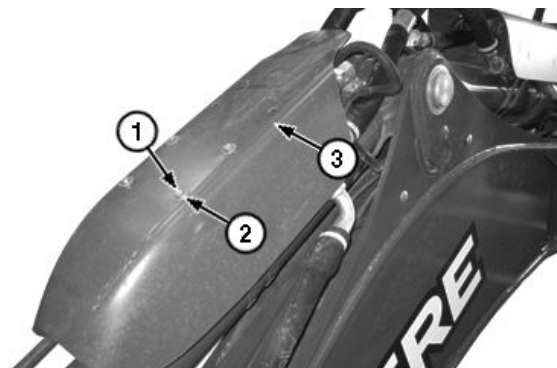

Electrohydraulic Distributed Valve Cover

1— Cap Screw (4 used)
2— Washer (4 used)

3— Electrohydraulic (EH)
Distributed Valve Cover

TX1119950A—UN—08AUG12

Continued on next page

SL78608,000085B -19-04SEP12-1/3

Hydraulic System

1. Remove drain plug (21) and O-ring (22).
2. Remove drain plugs (25) and O-rings (24).
3. Remove flange nuts (3), backhoe crowd in and out supply and return electrohydraulic poppet valves (EHPV) (Y91—Y94), and electrohydraulic proportional valves (1 and 4).
4. Remove backup rings (27 and 34) and O-rings (32, 33, 35, and 36) from backhoe crowd in and out supply and return EHPV.
5. Remove check valve (23), O-ring (24), poppet (30), and spring (31).
6. Remove dust cap (17), plug (28), O-ring (16), backup ring (15), O-ring (14), and manual lower hydraulic valve (13).
7. Remove pressure relief valves (5 and 12), O-rings (10, 9, 8, and 7), and backup rings (6).
8. Remove cap screws (20), crowd distributed function control unit (CWD) (A91), and O-rings (19).
9. Clean and inspect parts for contamination, wear, or damage. Replace as necessary.

NOTE: Do not use grease on any O-rings or seals on distributed valve components. Only use hydraulic oil used in machine or engine oil to lubricate O-rings or seals.

10. Install O-rings (19), CWD, and cap screws. Tighten cap screws in an "X" shape pattern to specification.

Specification

Crowd Distributed Function Control Unit (CWD) Cap Screw—Torque.....	5—5.5 N·m 40—48 lb.-in.
--	----------------------------

11. Install backup rings (6), O-rings (7, 8, 9, and 10), and pressure relief valves (5 and 12). Tighten pressure relief valves to specification.

Specification

Pressure Relief Valve—Torque.....	22—27 N·m 192—240 lb.-in.
--------------------------------------	------------------------------

12. Install manual lower hydraulic valve, O-ring (14), backup ring (15), O-ring (16), plug, and dust cap. Tighten manual lower hydraulic valve and plug to specification.

Specification

Plug—Torque.....	12—15 N·m 106—133 lb.-in.
Manual Lower Hydraulic Valve—Torque.....	2—3 N·m 18—27 lb.-in.

13. Install spring (31), poppet, O-ring (24), and check valve. Tighten check valve to specification.

Specification

Check Valve—Torque.....	163—176 N·m 120—130 lb.-ft.
-------------------------	--------------------------------

14. Install new backup rings (27 and 34) and O-rings (32, 33, 35, and 36) to backhoe crowd in and out supply and return EHPV.

15. Install electrohydraulic proportional valve (1 and 4), backhoe crowd in and out supply and return EHPV (Y91—Y94), and flange nuts. Tighten electrohydraulic proportional valve to specification with JDG10530 Electrohydraulic Proportional Valve Socket. Tighten flange nuts to specification.

Specification

Electrohydraulic Proportional Valve—Torque.....	170—183 N·m 125—135 lb.-ft.
Flange Nut—Torque.....	4—5 N·m 36—44 lb.-in.

16. Install O-rings (24) and drain plugs (25). Tighten to specification.

Specification

Drain Plug (25)—Torque.....	108—136 N·m 80—100 lb.-ft.
-----------------------------	-------------------------------

17. Install O-ring (22) and drain plug (21). Tighten to specification.

Specification

Drain Plug (21)—Torque.....	16—22 N·m 144—192 lb.-in.
-----------------------------	------------------------------

JR05199,00008D4 -19-21AUG12-3/3

DFRW20 Compressor Holding Fixture

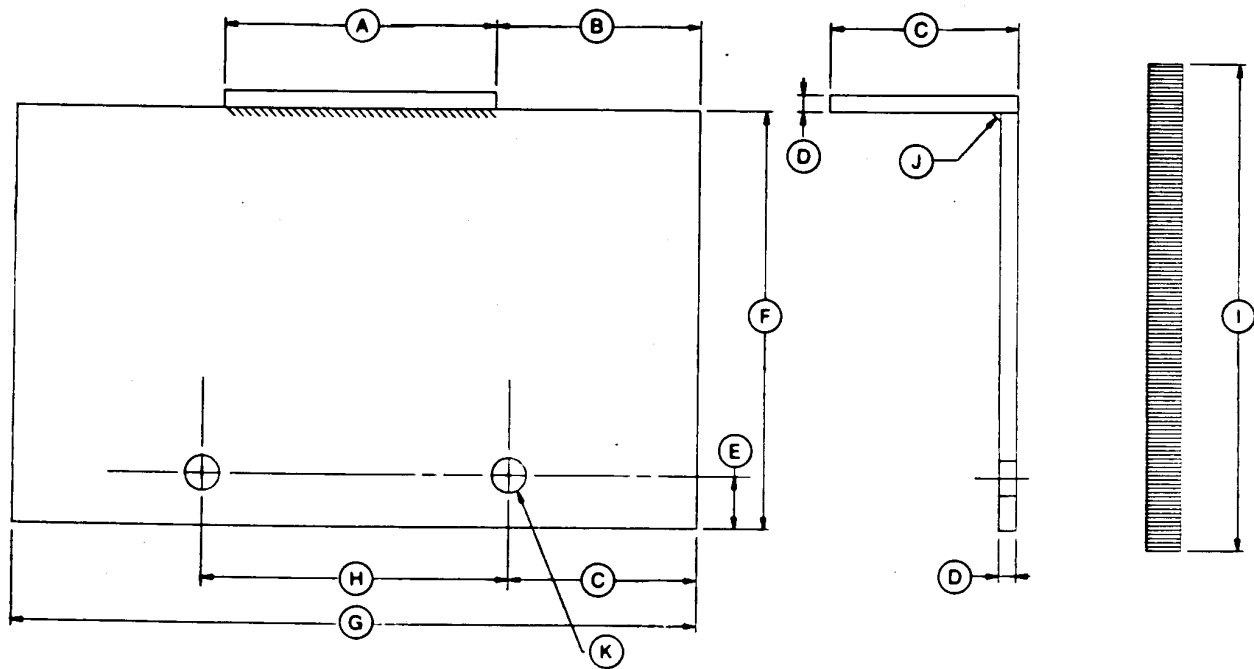

RW13619—UN—20SEP89

A—102 mm (4 in.)
B—76 mm (3 in.)
C—70 mm (2.75 in.)

D—6.4 mm (0.25 in.)
E—19 mm (0.75 in.)
F—152 mm (6 in.)

G—254 mm (10 in.)
H—114 mm (4.5 in.)
I—178 mm (7 in.)

J—Fillet Weld
K—Two Holes

This tool is used to hold the air conditioning compressor during disassembly and assembly.

MATERIALS:

- Two pieces of steel plate, approximately 70 x 120 mm (2-3/4 x 4 in.) and 152 x 254 mm (6 x 10 in.)

- Two pieces of threaded rod, 13 mm (1/2 in.) threads x 178 mm (7 in.) long
- Four lock washers and nuts

SL78608,0000696 -19-04MAY12-1/1

Index

	Page		Page
A			
Air cleaner		Backhoe boom cylinder	
Remove and install	05-0520-1	Disassemble and assemble	33-3360-3
Air conditioner freeze control switch		Remove and install	33-3360-1
Remove and install	18-1830-11	Backhoe boom lock	
Air conditioner system		Remove and install	33-3315-5
R134a refrigerant oil information.....	18-1830-2	Backhoe boom lock control lever and linkage	
Air conditioning		Remove and install	33-3315-1
Cleaning procedures.....	18-1830-6	Backhoe bucket and bucket links	
Leak testing.....	18-1830-3	Remove and install	33-3302-1
R134a station installation.....	18-1830-4	Backhoe bucket cutting edge	
R134a system charge.....	18-1830-5	Remove and install	33-3302-4
R134a system recover.....	18-1830-4	Backhoe bucket cylinder	
Refrigerant handling.....	18-1830-1	Disassemble and assemble	33-3360-5
Refrigerant hoses and tubing		Remove and install	33-3360-4
inspection.....	18-1830-3	Backhoe bucket tooth tips	
Air conditioning system		Remove and install	33-3302-1
Flush and purge.....	18-1830-7	Backhoe crowd cylinder	
Air suspension seat		Disassemble and assemble	33-3360-7
Disassemble and assemble.....	18-1821-1	Remove and Install	33-3360-6
Antenna		Backhoe extendable dipperstick cylinder	
Remove and install	20-2001-2	Disassemble and assemble	33-3360-13
Attachment coupler		Remove and install	33-3360-12
Remove and install	31-3104-1	Backhoe stabilizer cylinder	
Attachment coupler cylinder		Disassemble and assemble	33-3360-9
Disassemble and assemble.....	31-3104-2	Remove and install	33-3360-8
Remove and install	31-3104-2	Backhoe swing cylinder	
Attachments		Disassemble and assemble	33-3360-11
Adding safely	00-0001-10	Remove and install	33-3360-10
Operating safely.....	00-0001-10	Backover accidents	
Auxiliary section		Avoid	00-0001-9
Electrohydraulic spool valve, disassemble		Backup alarm	
and assemble.....	33-3360-26	Remove and install	20-2004-1
Axle		Volume adjustment	20-2004-2
Front, MFWD remove and install	02-0240-1	Battery box	
MFWD, assemble	02-0240-17	Remove and install	19-1913-1
MFWD, disassemble.....	02-0240-2	Blower mode door motor	
Non-powered front, hub remove and		Remove and install	18-1830-8
install.....	02-0230-1	BOM	
Rear, assemble.....	02-0250-17	Remove and install	33-3360-37
Rear, disassemble	02-0250-5	Boom	
Rear, remove and install	02-0250-3	Backhoe, Remove and install	33-3340-3
Axle steering cylinder, mechanical front		Loader, remove and install.....	31-3100-1
wheel drive		Boom cylinder	
Disassemble and assemble.....	09-0960-19	Backhoe, disassemble and assemble.....	33-3360-3
Remove and install	09-0960-17	Boom cylinder, backhoe	
Axle, rear		Remove and install	33-3360-1
Gear tooth contact pattern, check.....	02-0250-51	Boom cylinder, loader	
B			
Backhoe auxiliary section		Remove and install	31-3160-1
Electrohydraulic spool valve, disassemble		Boom distributed function control unit	
and assemble.....	33-3360-26	Remove and install	33-3360-37
Backhoe boom		Boom valve	
Remove and install	33-3340-3	Electrohydraulic, disassemble and	
		assemble.....	33-3360-37
		Brake disk and pressure plate	
		Remove and install	10-1011-1
		Brake pedal	
		Adjustment.....	10-1060-5

Continued on next page

CLICK HERE TO **DOWNLOAD** THE COMPLETE MANUAL

- Thank you very much for reading the preview of the manual.
- You can download the complete manual from: www.heydownloads.com by clicking the link below



- Please note: If there is no response to CLICKING the link, please download this PDF first and then click on it.

CLICK HERE TO **DOWNLOAD** THE COMPLETE MANUAL