

Form No. 913309

Revision B

For use on the following models:

Gehl: RS5-19

Mustang: 519

REPAIR

PUMP A 4 VG 40 - 56

Serie 3.2

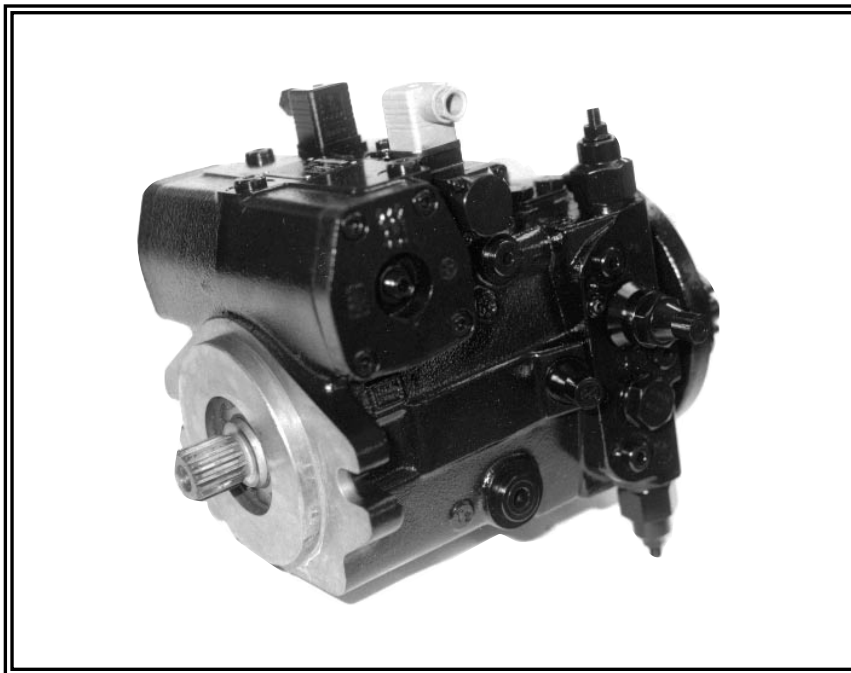

CLICK HERE TO **DOWNLOAD** THE COMPLETE MANUAL

- Thank you very much for reading the preview of the manual.
- You can download the complete manual from: www.heydownloads.com by clicking the link below



- Please note: If there is no response to CLICKING the link, please download this PDF first and then click on it.

CLICK HERE TO **DOWNLOAD** THE COMPLETE MANUAL

REPAIR INSTRUCTIONS

Sealing of the valves

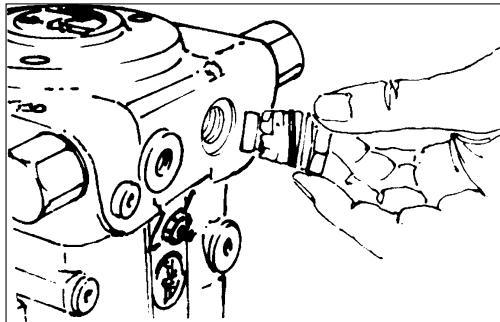
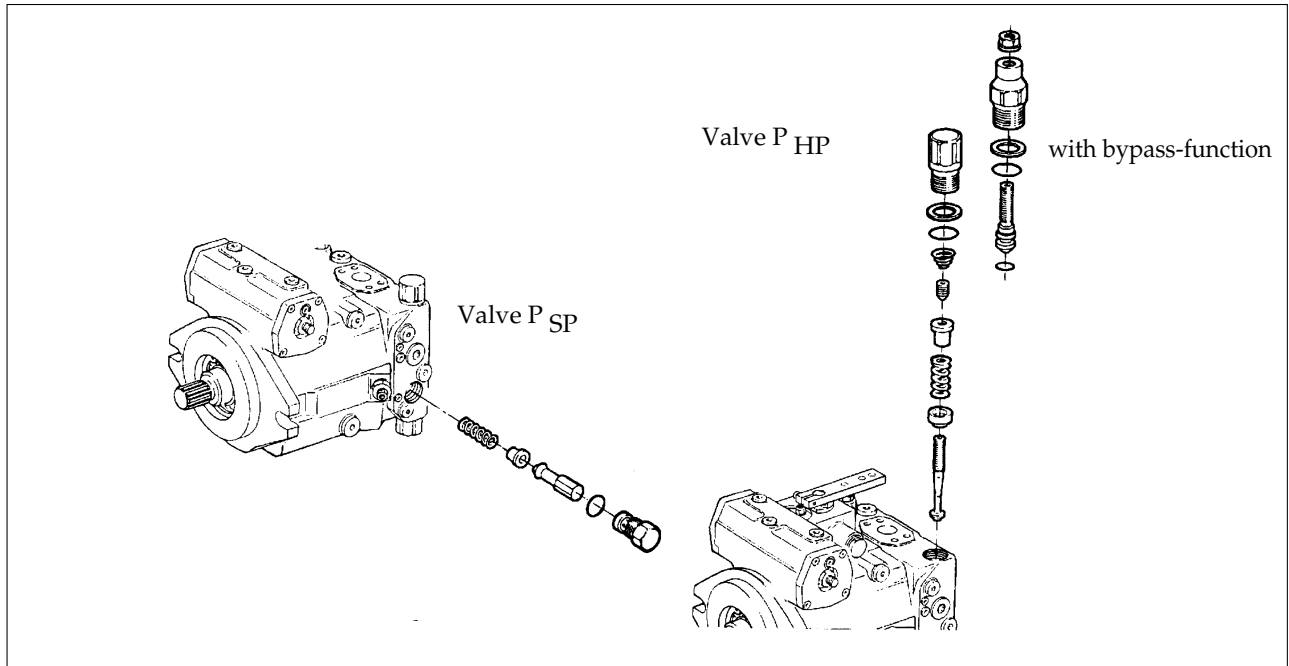

Cover threads before fitting new O-rings.
(Damage protection).

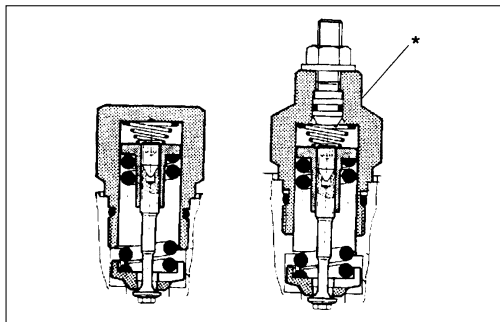

Remove valve poppet with spring.
* with bypass-function

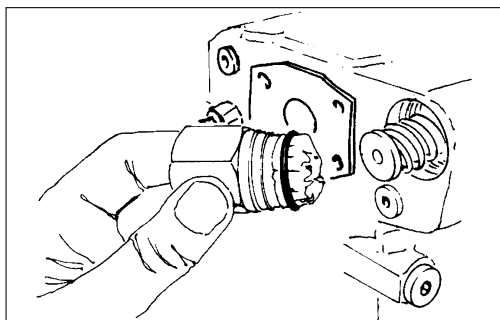

Cover threads before fitting new O-rings.
(Damage protection).

REPAIR INSTRUCTIONS

Inspection of rotary group parts

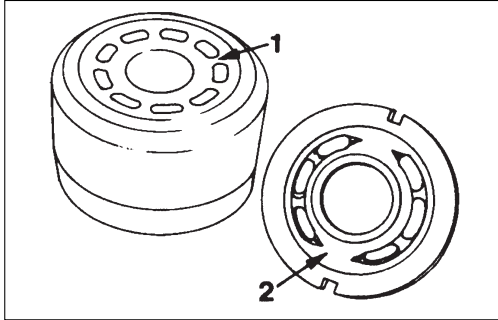

Check !

Cylinder gilding surface (1), free of scratches, no traces of wear and no embedded foreign particles. No scratches on the valve plate (2) (Replace ONLY in sets).

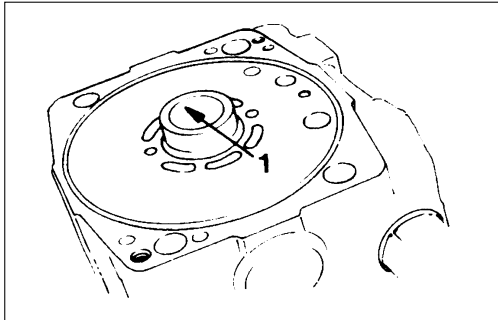

Check !

DU-bearing bush (1) is not worn out.

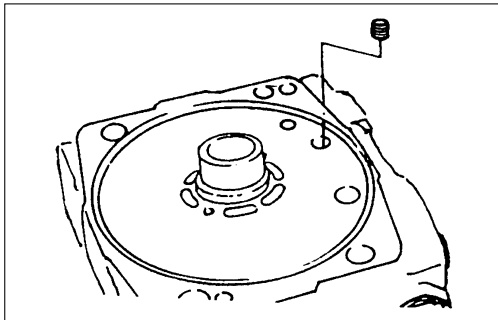

Information :

Boring for DA-control open.
Without DA-control closed.

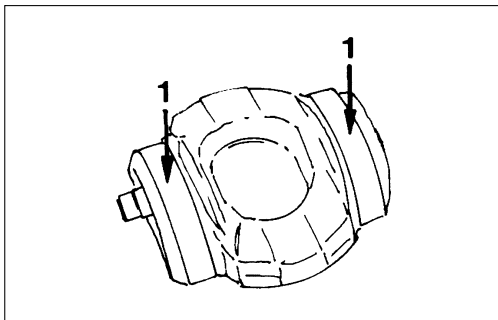

Check !

Bearing surfaces (1).

SWEEP AND BOOST VALVE

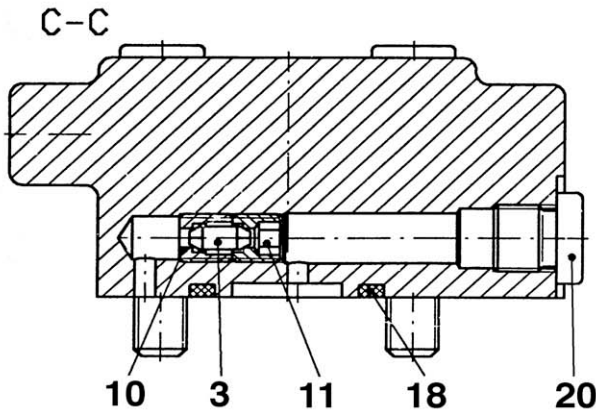
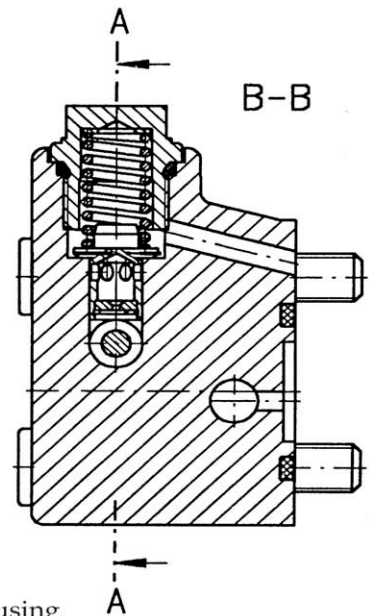
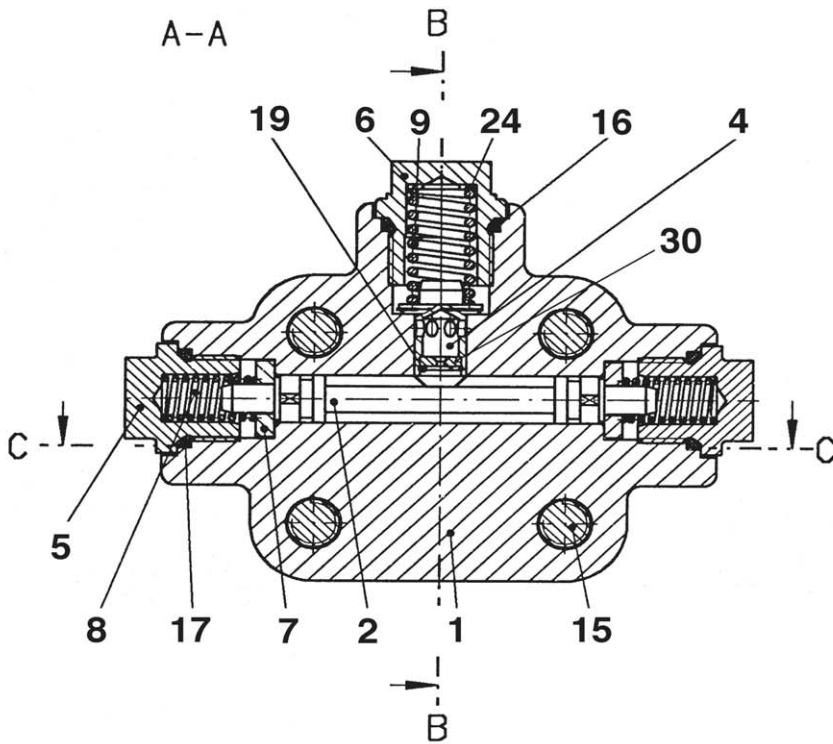
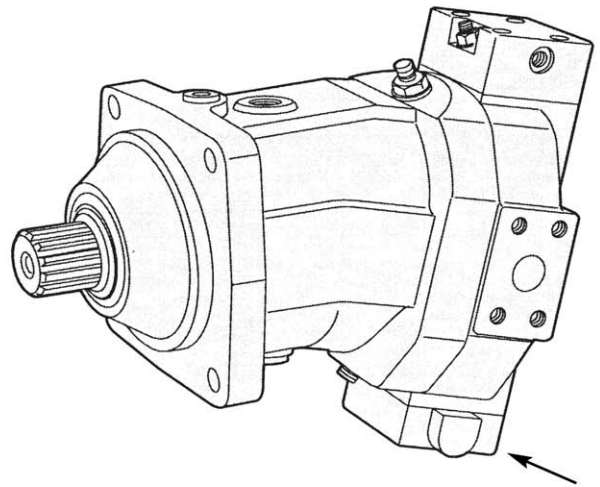

- 1 - Housing
- 2 - Sweep slide valve
- 3 - Neck : pin
- 4 - Valve slide
- 5 - Plug
- 6 - Plug
- 7 - Washer
- 8 - Pressure spring
- 9 - Pressure spring
- 10 - Nozzle
- 11 - Nozzle
- 15 - Screw
- 16 - O ring joint
- 17 - O ring joint
- 18 - O ring joint
- 19 - Retaining ring
- 20 - Plug
- 24 - Adjusting washer
- 30 - Calibrated orifice

**PRESSURE MEASURING POINTS
PUMP A 4 VG 56 DA**

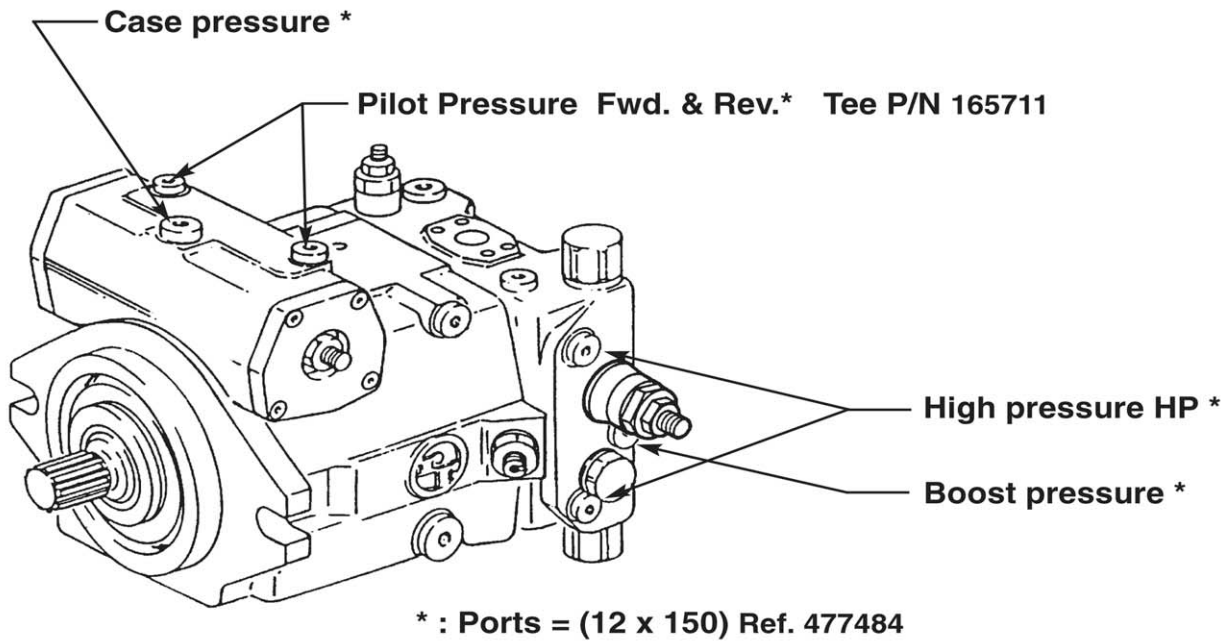

CLICK HERE TO **DOWNLOAD** THE COMPLETE MANUAL

- Thank you very much for reading the preview of the manual.
- You can download the complete manual from: www.heydownloads.com by clicking the link below



- Please note: If there is no response to CLICKING the link, please download this PDF first and then click on it.

CLICK HERE TO **DOWNLOAD** THE COMPLETE MANUAL