

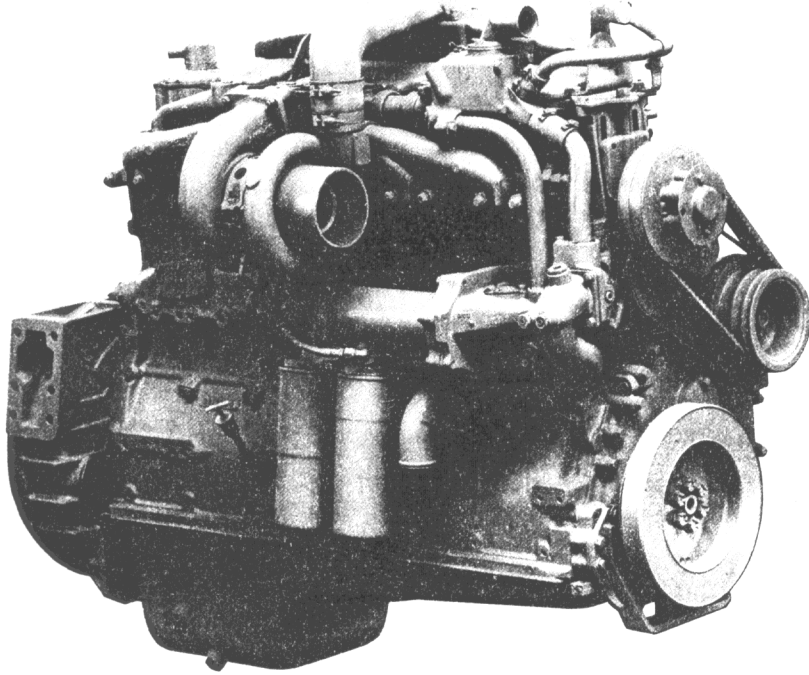

Troubleshooting and Repair Manual Big Cam III and Big Cam IV, NT 855 Engines

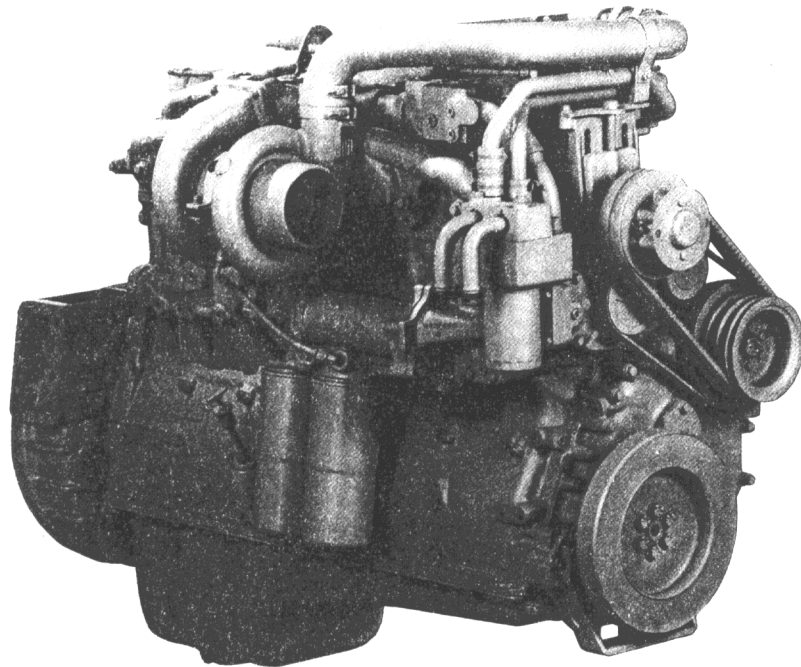

Big Cam III



Big Cam IV

CLICK HERE TO **DOWNLOAD** THE COMPLETE MANUAL

- Thank you very much for reading the preview of the manual.
- You can download the complete manual from: www.heydownloads.com by clicking the link below



- Please note: If there is no response to CLICKING the link, please download this PDF first and then click on it.

CLICK HERE TO **DOWNLOAD** THE COMPLETE MANUAL

Definition of Terms

The following is a list of guidelines for each procedure in the "Repair Sections" of the Troubleshooting and Repair Manual. The procedure will be given first, followed by a definition of the step or steps involved.

Check - Examine a component or system for damage, excessive wear, accuracy, safety, or performance.

Inspect - Examine a component or dimension to make sure it meets the required specifications.

Test - Check or compare the performance of a component or system to established specifications.

Adjust - Complete the necessary steps to set or adjust the component, assemblies, or system in the required setting or position.

Visually Inspect - Look for any obvious damage or problem.

Remove - Take off a component or assembly.

Clean - Remove dirt, grease, or other contamination.

Disassemble - Take apart the component or assembly.

Repair - Restore a component or assembly to a serviceable condition within the established specifications.

NOTE: Only the easiest and simplest repairs will be made to a component or assembly. If a component or assembly **must** be rebuilt, it **must** be replaced with a new or Cummins Diesel ReCon®, Inc. replacement or be rebuilt at a Cummins authorized repair location.

Replace - Install a new, correctly rebuilt, or Cummins Diesel ReCon®, Inc. component or assembly in place of the one which is removed.

Install - Place a component or assembly in the correct position.

Star Pattern Torque Sequence -

Troubleshooting Symptoms

	Page No.
1. Air Compressor Operates With Excessive Noise	31
2. Air Compressor Pumping Excessive Lubricating Oil Into Air System	28
3. Air Compressor Air Pressure Rises Slowly	26
4. Air Compressor Will Not Maintain Adequate Air Pressure (Not Pumping Continuously).....	27
5. Air Compressor Will Not Pump Air Pressure	29
6. Air Compressor Will Not Stop Pumping Air	30
7. Alternator Malfunctioning	62
8. Connecting Rod Bearing Noise	72
9. Coolant in the Lubricating Oil	21
10. Coolant Loss (External).....	9
11. Coolant Loss (Internal).....	11
12. Coolant Loss (Overflow).....	8
13. Coolant Temperature Above Normal	3
14. Coolant Temperature Below Normal	6
15. Engine Crankcase Gases (Blowby) - Excessive.....	63
16. Engine Cranks, But Will Not Start (No Exhaust Smoke)	32
17. Engine Decelerates Poorly.....	52
18. Engine Hard to Start, or Will Not Start (Exhaust Smoke Present).....	34
19. Engine Power Output Low	45
20. Engine Noise - Excessive *	65
21. Engine Runs Rough or Misfires In Operating Range (Warm Engine).....	38
22. Engine Starts But Will Not Keep Running	36
23. Engine Surges at High Idle	54
24. Engine Surges at Low Idle.....	42
25. Engine Surges While Operating at Rated RPM and Load	53
26. Engine Vibration - Excessive	64
27. Engine Will Not Crank or Cranks Slowly	61
28. Engine Will Not Reach Rated Speed When Loaded	43
29. Engine Will Not Shut Off.....	51
30. Excessive White Smoke at Idle	68
31. Exhaust Smoke Under Load - Excessive.....	49
32. Fuel Consumption - Excessive	60
33. Fuel in the Coolant	12
34. Fuel in the Lubricating Oil.....	22
35. Idle - Rough.....	40
36. Low Power or Excessive Smoke (Low Turbocharger Boost Pressure)	24
37. Lubricating Oil Consumption - Excessive	18
38. Lubricating or Hydraulic Oil in the Coolant.....	17
39. Lubricating Oil Pressure-High	15
40. Lubricating Oil Pressure-Low	13
41. Lubricating Oil Sludge in the Crankcase - Excessive	20
42. Lubricating Oil Temperature Above Normal	16
43. Main Bearing Noise	71
44. Mechanical Variable Timing Will Not Switch to Advanced or Retarded Timing Mode	66
45. Piston Noise	73
46. Surge in Top Gear - Road Speed Governor Not Set Correctly	55
47. Throttle Response Slow (Engine Dies Going Downhill).....	59
48. Turbocharger Leaks (Engine Oil or Fuel)	25
49. Turbocharger Noise	23
50. Variable Speed (VS) Governor Surge - Engine Under Load	56
51. Variable Speed (VS) Governor (Fuel Leakage at).....	57
52. Variable Speed (VS) Governor Speed Not Set Correctly	58
53. White Smoke - General Information	67

*Refer to "General Engine Noise Diagnostic Procedures" on page 70 for appropriate diagnostic procedures.

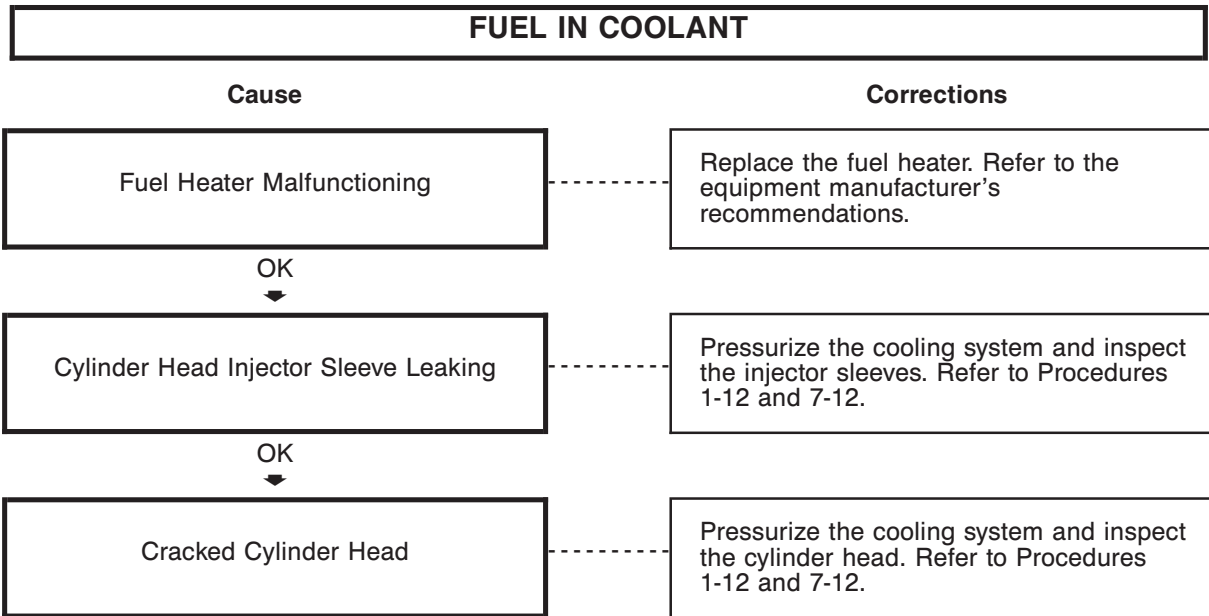

FUEL IN THE LUBRICATING OIL	
Cause	Corrections
Low Oil and Coolant Temperatures Caused by Long Periods of Engine Idling	Turn off engine rather than idle for long periods. If long idle is necessary, raise idle speed. Refer to Procedure 5-05.
OK ↓	
Top Injector O-Ring Damaged	Check the injectors. Replace o-rings if necessary. Refer to Procedure 5-06.
OK ↓	
Injector Plunger Damaged	Remove the injector. Refer to Procedure 5-06. Check the barrel to plunger leakage. Refer to "Injectors PT Rebuild Manual," Bulletin No. 3379071.
OK ↓	
Injector Adapter Wall Damaged Behind Balance Orifice	Check the injectors. Refer to Procedure 5-14.
OK ↓	
Injector Cup Damaged	Check the injector cups. Refer to "Injec- tors PT Rebuild Manual," Bulletin No. 3379071.
OK ↓	
Fuel Pump Main Shaft Seals Damaged	Replace the fuel pump. Refer to Procedure 5-07.
OK ↓	
Cylinder Head Cracked or Porous	Replace the cylinder head. Refer to Procedure 7-12.

**ENGINE CRANKS, BUT WILL NOT START
(NO SMOKE FROM EXHAUST)**

Cause	Corrections
No Fuel In Tank	Add fuel. Refer to Reference 5-02.
OK ↓	
Shutoff Valve Closed	Use manual override. Repair electrics. Refer to Procedure 5-10.
OK ↓	
No Fuel To Injectors	Loosen fuel rail line between fuel pump and cylinder head while cranking engine. Refer to Procedure 5-11.
OK ↓	
Fuel Connections Loose on Suction Side of Fuel Pump	Tighten all fuel filter fittings and connections from fuel tank to fuel pump. Refer to Procedure 5-12.
OK ↓	
Fuel Filter Plugged or Suction Line Restricted	Replace fuel filter. Inspect fuel hose for restriction. Refer to Procedures 5-08 and 5-15.
OK ↓	
No Fuel in Pump	Prime fuel pump. Refer to Procedure 5-11.
OK ↓	
Intake or Exhaust System Restricted	Check intake and exhaust system for restrictions. Refer to Procedures 3-08 and 3-09.
OK ↓	
Fuel Pump Not Turning	Check tachometer shaft for rotation while cranking. Replace pump if necessary. Refer to Procedure 5-11.
OK ↓	

(Continued)

ENGINE SURGES AT LOW IDLE

Cause

Corrections

Air In Fuel System

Check for air in fuel, tighten fuel connections, tighten filter, check tank stand pipe, check road speed governor. Refer to Procedure 5-12.

OK



Engine Idle Speed Set Low

Check and adjust low idle screw. Refer to Procedure 5-05.

OK



Automotive and VS Governor Idle Speed Set Too Close

Adjust automotive idle speed. Adjust VS idle speed. Refer to Procedure 5-05.

OK



Fuel Drain Line Restriction

Check lines and tank vents. Refer to Procedure 5-15.

OK



Throttle Leakage Set Wrong or Wrong Idle Parts

Set to proper throttle leakage, or replace fuel pump. Refer to Procedure 5-07.

POOR DECELERATION

Cause

Corrections

Throttle Return Spring or Linkage Binding

Check for free movement and adjust if necessary. Refer to Procedure 5-08.

OK
↓

Fuel Drain Lines Restricted

Check for loops, restricted fittings. Refer to Procedure 5-15.

OK
↓

Fuel Tank Vents Plugged

Remove and clean. Replace as necessary. Refer to Procedure 5-15.

OK
↓

Overhead Fuel Tank Check Valve Not Opening

Valve must open at 2 kPa [0.3 psi]. Incorrectly plumbed. Refer to Reference 5-02.

OK
↓

Install Compuchek®, If Available

Perform cylinder performance test. Refer to "Compuchek® Operation Manual," Bulletin No. 3377550.

OK
↓

Throttle Leakage Excessive

Remove pump. Calibrate on test stand. Refer to Procedure 5-07.

OK
↓

Injector Check Ball Not Seating or Missing

Remove injector(s), replace. Refer to Procedure 5-06.

AMMETER/VOLTMETER INDICATES ALTERNATOR IS NOT CHARGING, OR CHARGING AT A LOW RATE

Cause	Corrections
Gauge Defective	Connect voltmeter to battery terminal to check. Refer to Procedure 6-08.
OK ↓	
Alternator Belt Loose	Check belt tension. Refer to Procedure 6-07.
OK ↓	
Engine Idle Speed Too Low	Check engine idle speed. Refer to Procedure 5-05.
OK ↓	
Alternator Malfunctioning	Check alternator output. Refer to Procedure 6-08.
OK ↓	
System Electrically "Open" (Blown Fuses, Broken Wires, Loose Connections, Etc.)	Check connections, fuses, and wiring. Refer to manufacturer's wiring diagrams.

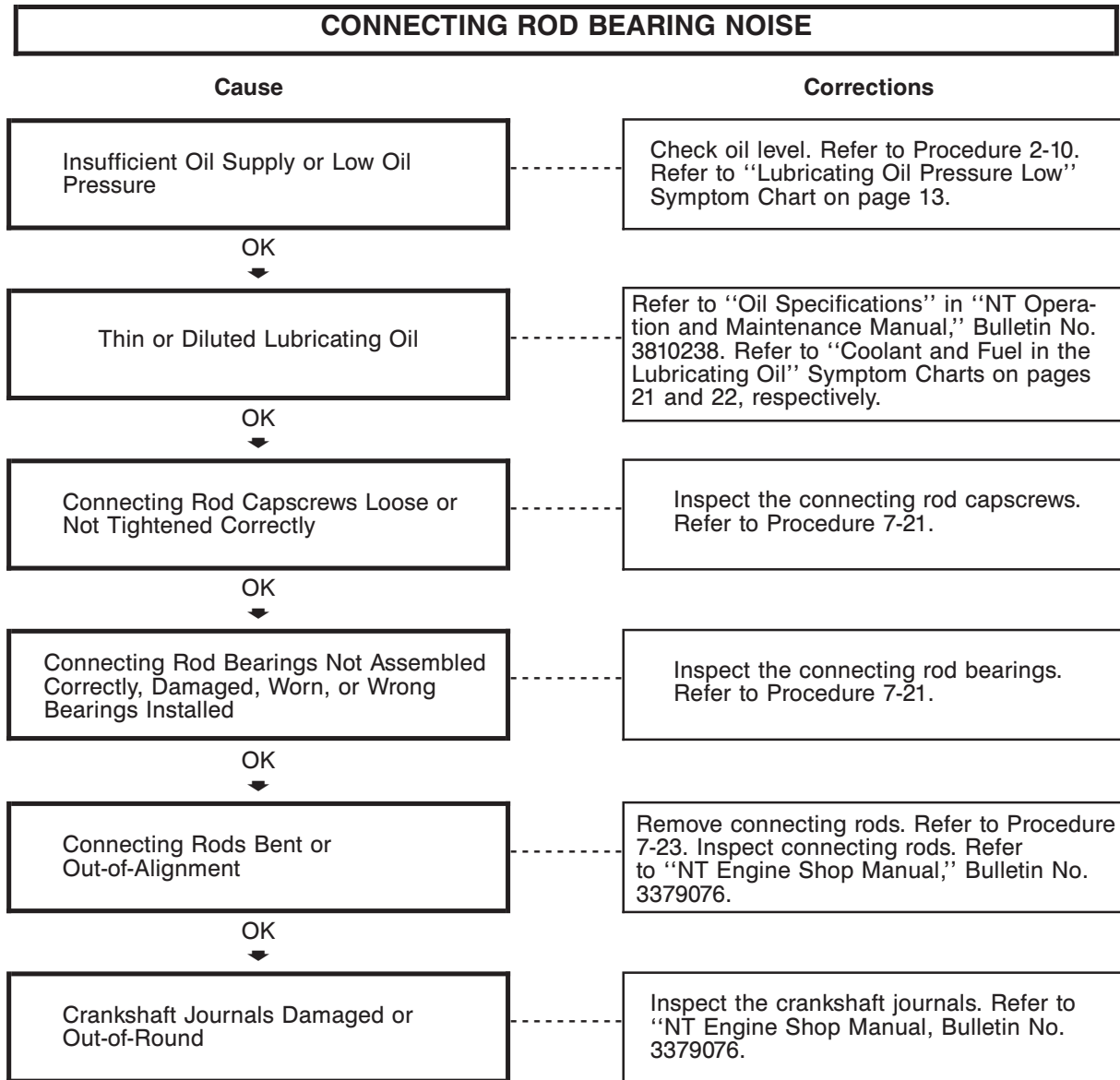

Cooling System Specifications - (1-02)

	Big Cam III - Traditional	Big Cam IV - Optimized
Coolant Capacity (Engine Only)	21.0 litres [22.0 U.S. Qt.]	21.0 litres [22.0 U.S. Qt.]
Standard Modulating Thermostat-Range	82-93°C [180-200°F]	79.4-90.5°C [175-195°F]
Maximum Coolant Pressure (Exclusive of Pressure Cap) Closed Thermostat	276kPa [40 psi]	276kPa [40 psi]
Maximum Allowable Top Tank Temperature	100°C [212°F]	100°C [212°F]
Minimum Recommended Top Tank Temperature.....	70°C [158°F]	70°C [158°F]
Maximum Allowable Deaeration Time	25 minutes	35 minutes
Minimum Allowable Drawdown or 20% of System Capacity (Whichever is Greater)	10.4 litres [11 U.S. Qt.]	11.5 litres [12 U.S. Qt.]
Minimum Allowable Pressure Cap	50kPa [7 psi]	50kPa [7 psi]
Maximum Allowable Coolant Flow to Accessories	—	1.3 litres/sec [20 U.S. Gal/Min]
Minimum Cooling Capability @ Nominal Fuel Rate		
• Air to Boil @ 1500 RPM @ 25 Km/h [15 MPH] Ram Air	40°C [104°F]	—
• Air to Boil @ 2100 RPM @ 25 Km/h [15 MPH] Ram Air	45°C [113°F]	—
Maximum Cooling Differential @ Nominal Fuel Rate @ 25 Km/h [15 MPH] Ram Air and 50/50 Ethylene Glycol Coolant		
• Engine Out Coolant to Ambient @ 1900 RPM.....	—	41.1°C [106°F]
• Engine Out Coolant to Ambient @ 1300 RPM.....	—	46.0°C [115°F]
• Engine Inlet Coolant to Ambient @ 1900 RPM & 1300 RPM.....	—	5.6°C [42°F]

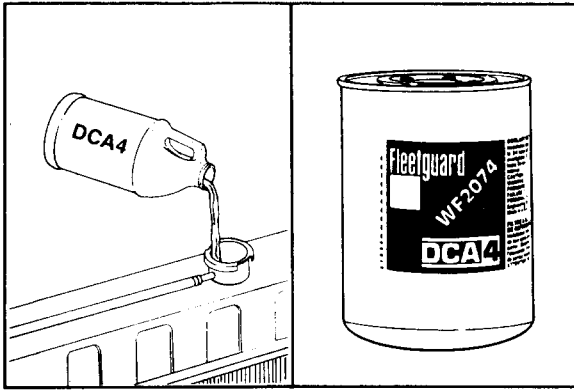

Coolant Additives and Filters

Diesel Coolant Additives (DCA4) (or equivalent) are required to protect the cooling system from fouling, solder blooming, and general corrosion. The coolant filter is required to protect the coolant system from abrasive materials, debris, and precipitated coolant additives.

Cooling System, Drain - (1-06)

1. Position the vehicle on level ground.

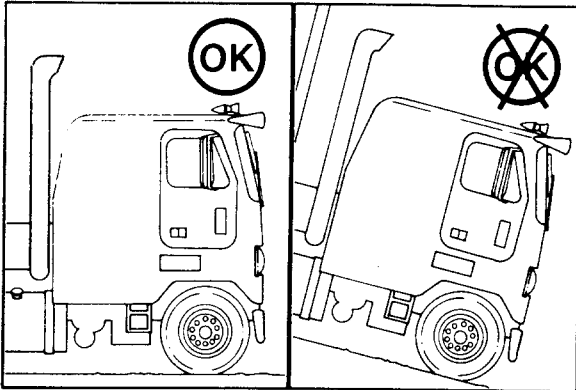

Warning: Wait until the temperature is below 50°C [120°F] before removing the coolant system pressure cap. Failure to do so can cause personal injury from heated coolant spray.



2. Remove the radiator cap after the engine is cool.

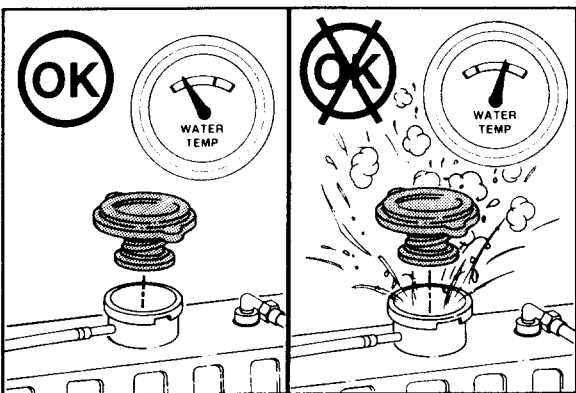

3. Drain the cooling system as follows:



- Open the radiator draincock.
- Remove the lower radiator hose(s).
- Open the aftercooler draincock (Big Cam IV only).

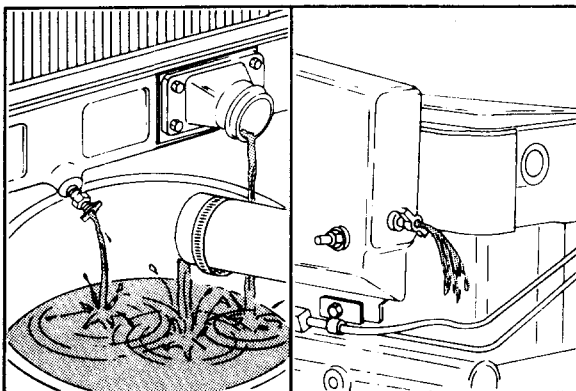

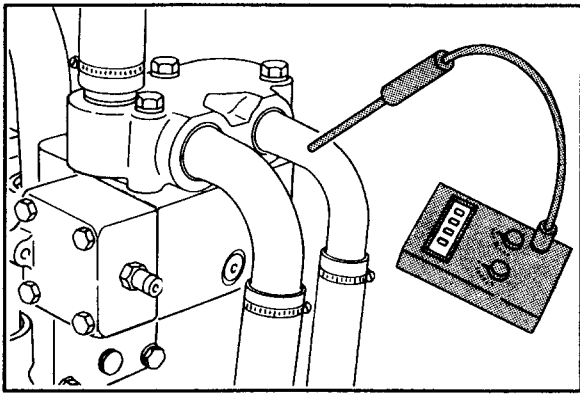

Fan And Shutter Air Control Valve Check

Caution: The engine can overheat with the fan control or the shutter air control valve disconnected. Monitor the engine coolant temperature while performing this test. The coolant temperature must not exceed 100°C [212°F].

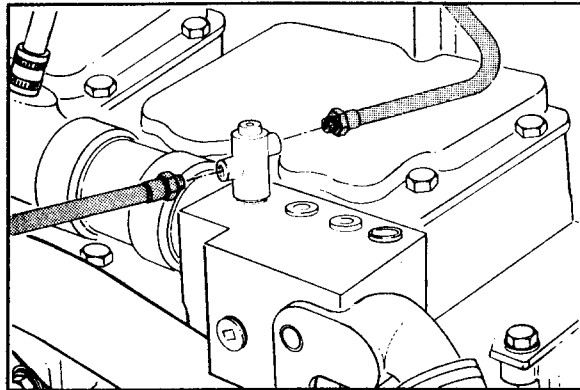

1. Disconnect the vehicle air supply hose to the fan and the shutter air control valve. Install a plug in the air supply hose. If the vehicle is equipped with an air control valve for both the fan and the shutters, check only one valve at a time.

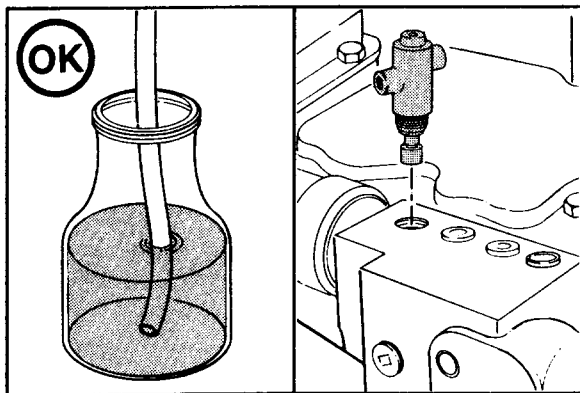

2. Repeat the test for air in the cooling system as previously described. If no air is found in the cooling system with the air control valve(s) isolated, install a new control valve.

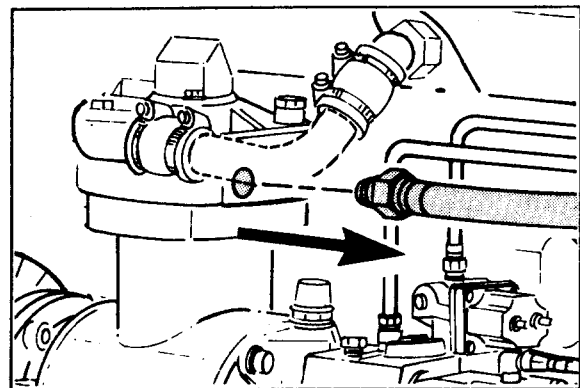

Air Compressor Check

Caution: The air compressor discharge line must be disconnected at the compressor to allow the compressor to discharge air to the atmosphere during this next test to prevent the compressor from overheating. Do not run the engine over 5 minutes with components isolated from the cooling system. Component damage can occur.

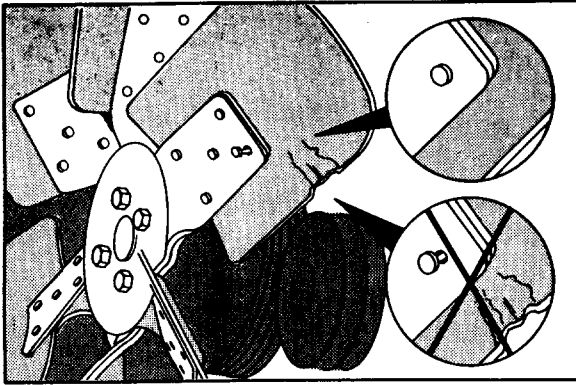

1. Visually check the fan for cracks, loose rivets, and bent or loose blades. Check the fan to make sure it is securely mounted. Tighten the capscrews if necessary. Replace damaged fans.

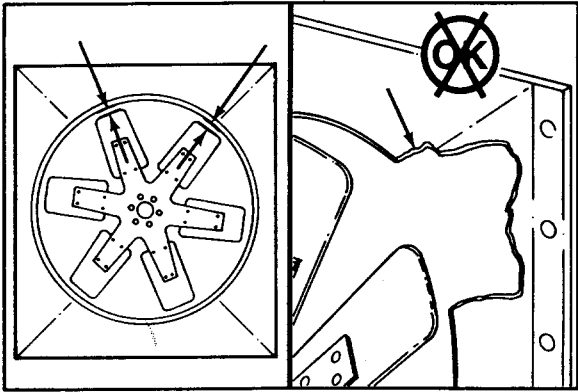

Fan Shroud

1. Inspect the fan shroud for the correct fan clearance. Refer to the vehicle manufacturer's specifications.
2. Visually inspect the shroud for cracks, air leaks, or damage. Replace if necessary. Refer to the manufacturer's instructions.

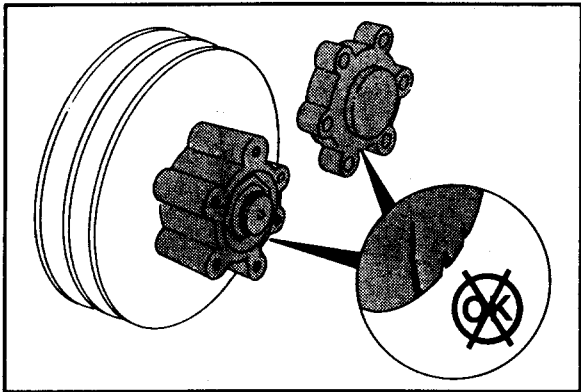

Fan Spacer And Pulley

1. Visually inspect the fan hub and the spacer (if used) for cracks or damage. Replace if necessary. Refer to Procedures 1-26 and 1-18, respectively.

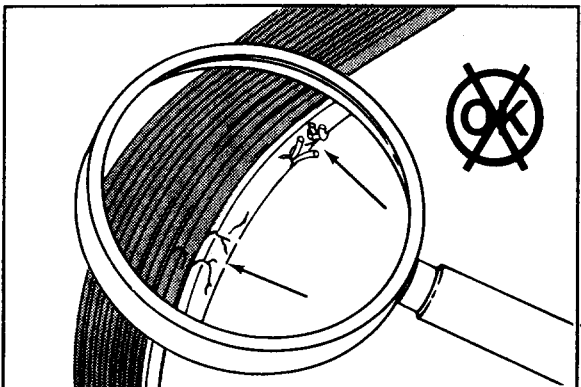

Water Pump Belt - Replace (1-19)

Inspect

1. Visually inspect the belt for the following:
 - Cracks.
 - Glazing.
 - Tears or cuts.

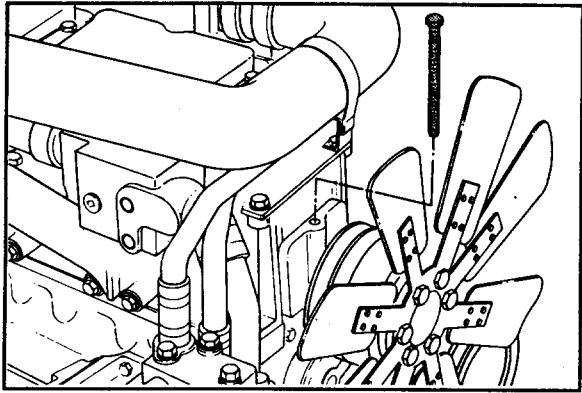

4. Install the fan hub adjusting screw.

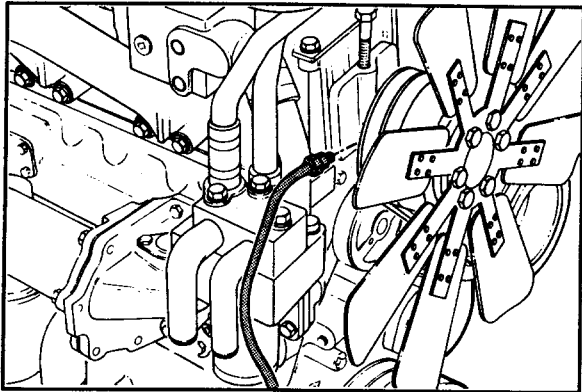

5. Install the fan hub signal line. Tighten the fan belts per Procedure 1-20.

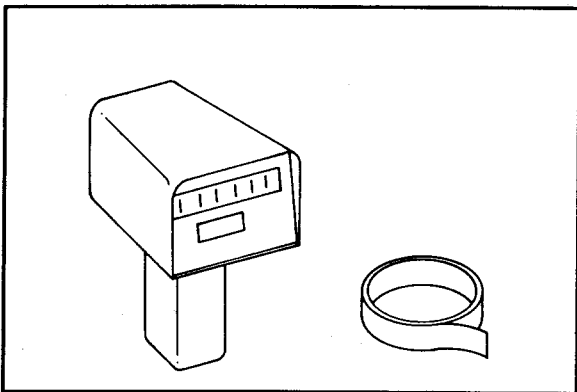

Fan Clutch, Viscous-Type - (1-25)

Check

1. Use a fan RPM measuring device to check the operation of the viscous fan hub. A strobe or Part No. 3377462 Cummins Optical Tachometer may be used.

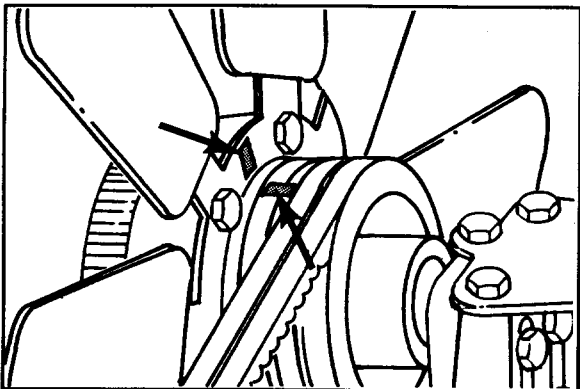

2. Mark a spot on the fan hub pulley and one fan blade so the measuring device can determine the pulley and the fan speed. Reflective tape, Part No. 3377464, in Part No. 3377462 Cummins Optical Tachometer, can be used to mark the fan blade and the pulley. (Refer to Service Tools Instruction, Bulletin No. 3377544, for more information.)

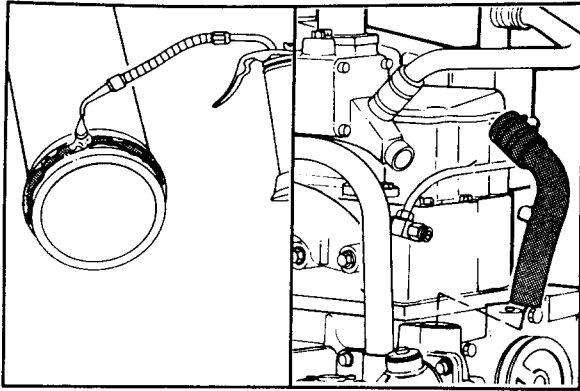

7. Inspect the O-ring on the coolant transfer tube. Replace if necessary.
8. Lubricate the O-ring with lubricating oil, and install the coolant transfer tube into the water pump.

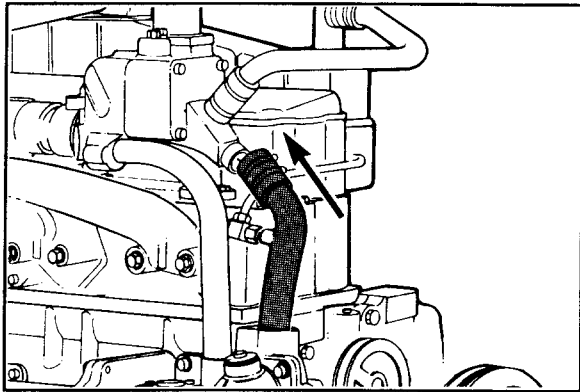

9. Install the hose on the coolant transfer tube, and tighten the clamps.
10. Install the air compressor coolant outlet tube.
11. Install the coolant filter coolant outlet tube (if previously connected to the water pump).

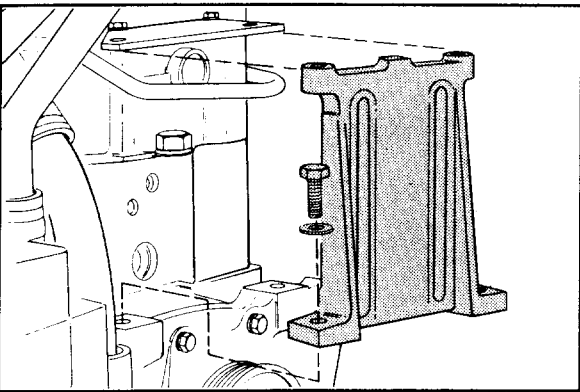

12. Install the fan hub support bracket to the water pump housing.
13. Tighten the bottom capscrews to 100 N•m [75 ft-lbs] torque.
14. Tighten the top capscrews to 100 N•m [75 ft-lbs] torque.

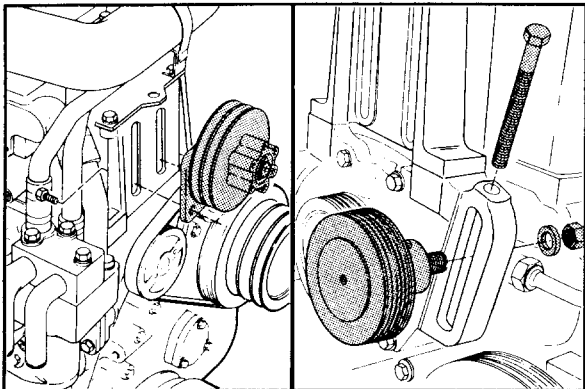

15. Install the fan hub and the water pump idler pulley assembly. Refer to Procedures 1-26 and 1-27, respectively.

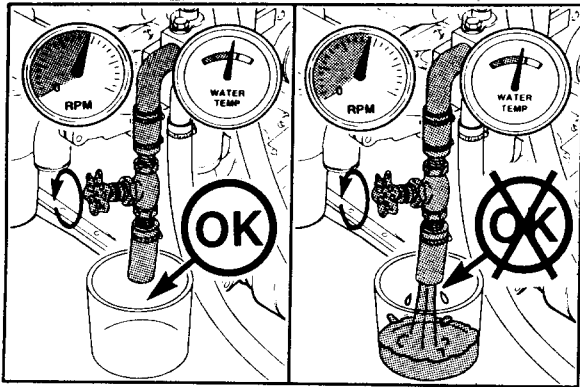

16. Carefully open the valve, and check for coolant flow. If there is any continuous coolant flow above 90°C [190°F], the thermostat is defective or incorrectly installed in the thermostat housing. Refer to Procedure 1-36.

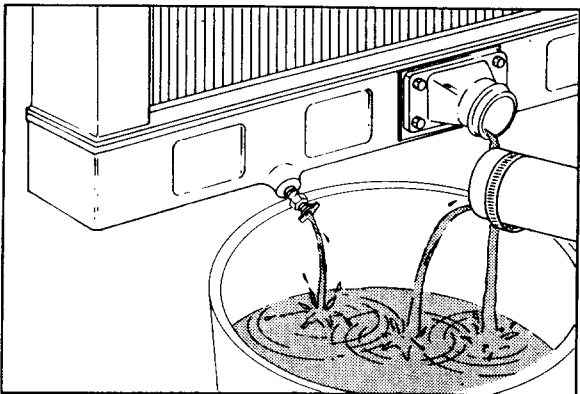

Thermostat housing (Big Cam IV) - Replace (1-35)

Remove

1. Drain the cooling system. Refer to Procedure 1-06.

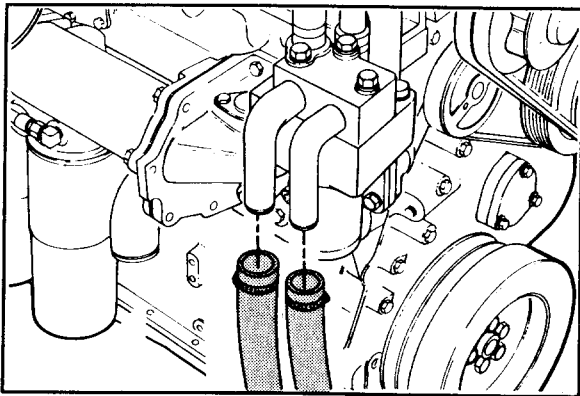

2. Loosen the engine inlet and outlet coolant hose clamps, and remove the hoses.

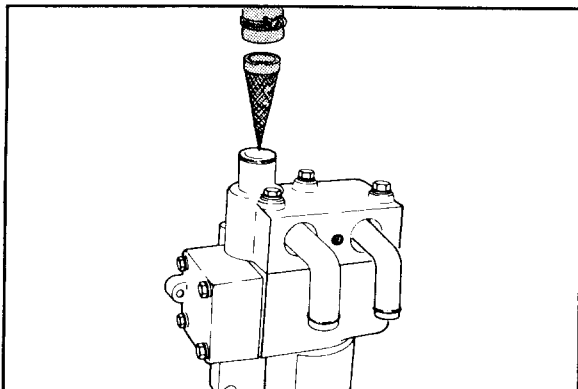

3. Loosen the clamp on the thermostat housing to the aftercooler inlet hose. Remove the hose and the aftercooler inlet screen.

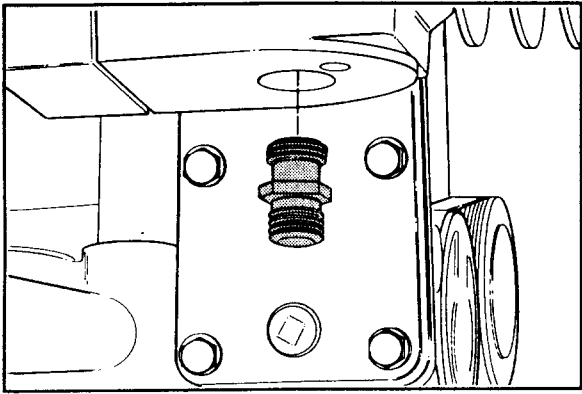

4. Install the insert into the thermostat housing, and tighten to 45 N•m [35 ft-lbs] torque.

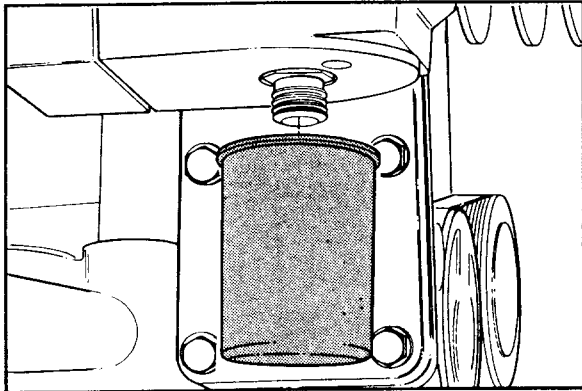

5. Install the coolant filter.

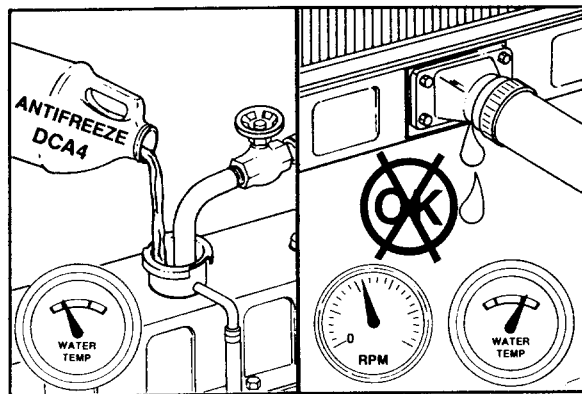

6. Fill the engine with coolant. Refer to Procedure 1-07. Start the engine, and check for leaks.

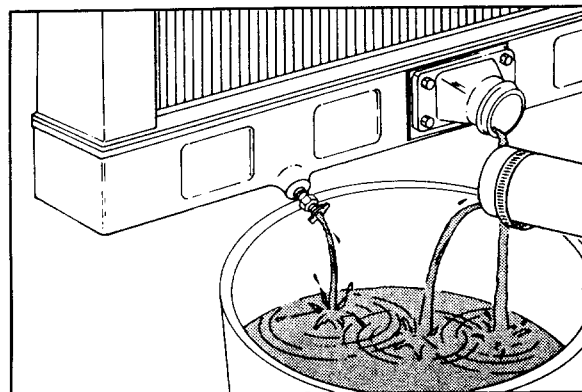

Thermostat Housing Check Valve Assembly (Big Cam IV) - Replace (1-40)

Remove and Install

1. Drain the cooling system. Refer to Procedure 1-06.

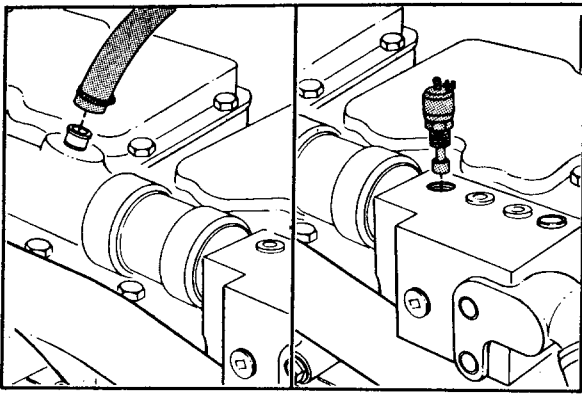

3. Install or connect the heater hose and the coolant temperature sensing units to the water manifold.

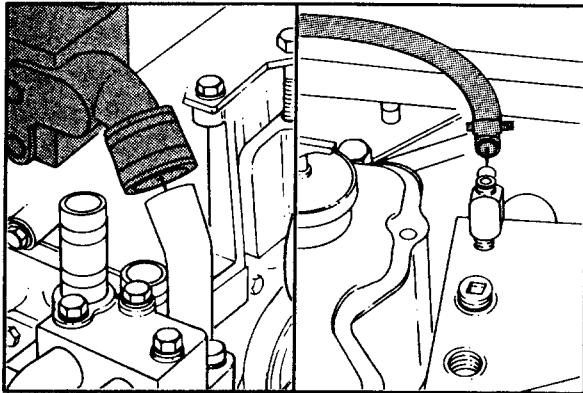

4. Install the water bypass tube and the coolant vent hoses to the front water manifold. Tighten the hose clamps to 5 N•m [40 in-lbs] torque.

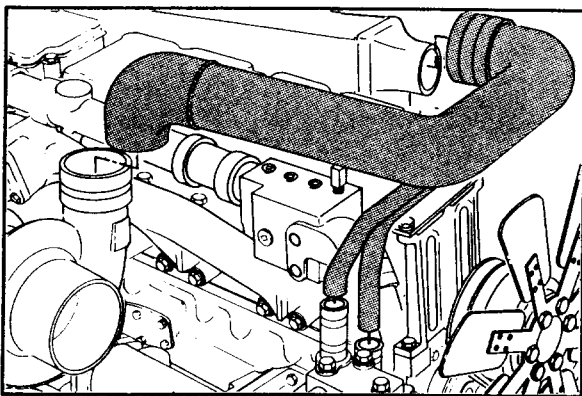

5. Install the aftercooler coolant inlet and outlet hoses. Tighten the hose clamps to 5 N•m [40 in-lbs] torque.

6. Install the air crossover tube. Tighten the hose clamps to 8 N•m [70 in-lbs] torque.

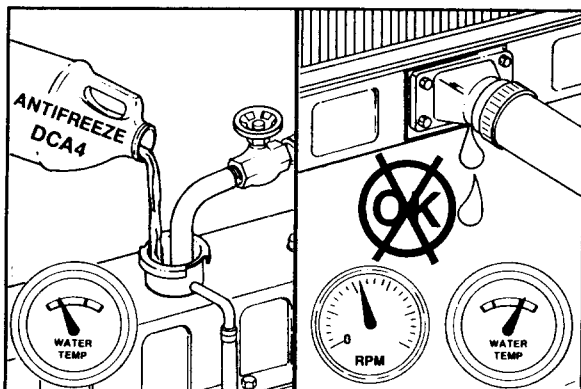

7. Fill the engine with coolant. Refer to Procedure 1-07. Start the engine, and check for leaks.

Lubricating Oil Cooler Bypass Valve

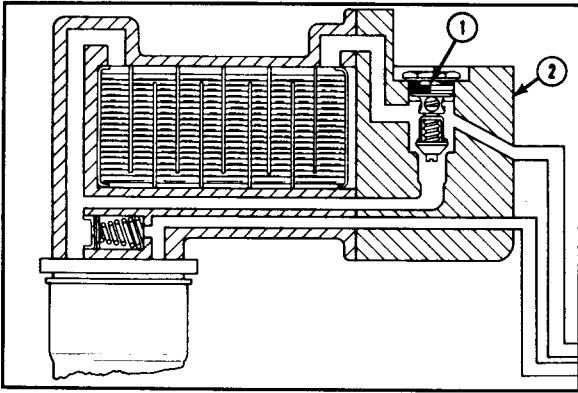

1. Oil flow through the oil cooler is controlled by a temperature sensitive bypass valve (1) in the oil cooler support (2).
2. The bypass valve is either open (retracted) or closed (extended), depending on the oil temperature.

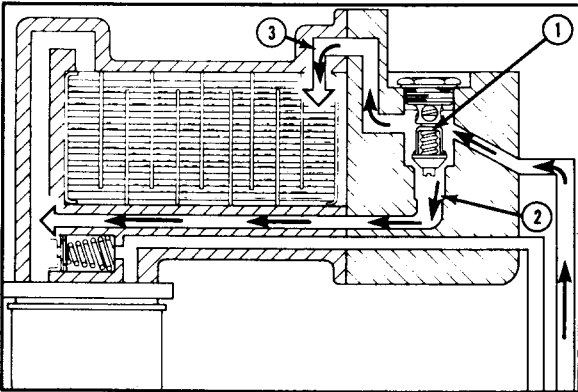

3. When the oil temperature out of the lubricating oil pump is below 110°C [230°F], the bypass valve is in the open (retracted) position (1).
4. With the bypass valve in the open position, approximately 60 percent of the oil from the lubricating oil pump bypasses the cooler through the bypass loop (2) and goes directly to the oil filter head.

The remaining 40 percent goes through the cooler core (3), and is cooled before it reaches the oil filter head.

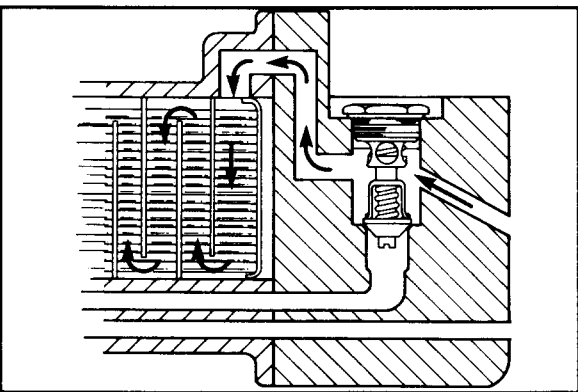

5. When the oil temperature exceeds 110°C [230°F] out of the lubricating oil pump, the bypass valve extends to close the bypass loop in the cooler assembly.

This forces all of the oil to flow through the cooler core before reaching the filter head.

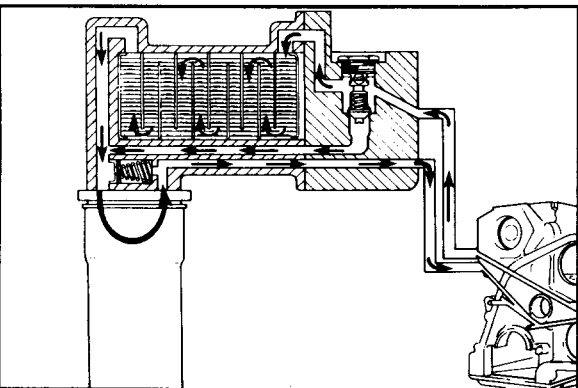

6. After the oil is cooled below 107°C [225°F], the bypass valve once again retracts to open the bypass loop, allowing 50 percent of the oil to bypass the cooler.

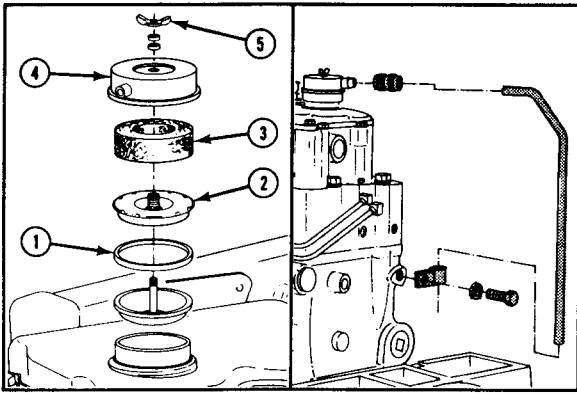

Assemble

1. Assemble the breather as shown, using a new or cleaned breather element and vapor barrier.
2. Install the vent tube, the hose, the hose clamps, the brackets, and the capscrews on the engine.
3. Tighten the capscrews to 25 N•m [20 ft-lbs] torque.

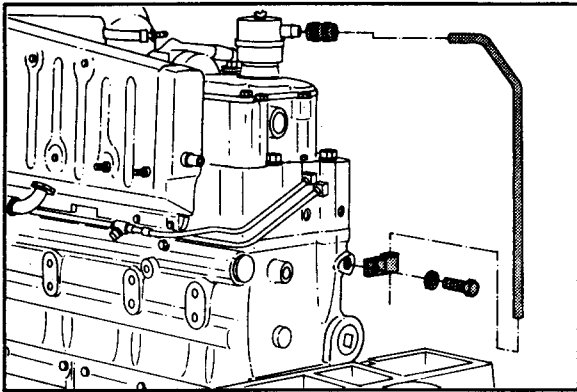

Crankcase Breather Tube - Remove

1. Loosen the hose clamp at the breather vent tube.
2. Remove the tube support bracket capscrews and the brackets.
3. Remove the tubes and the hoses from the engine.

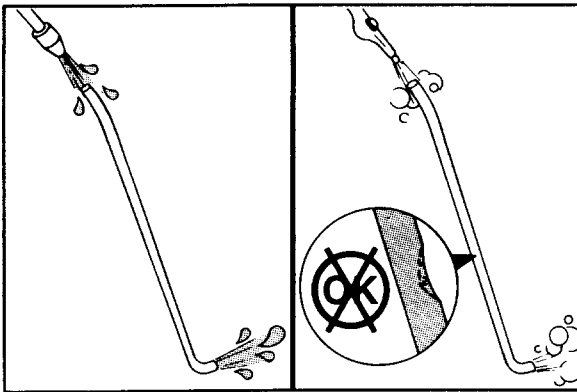

Clean

1. Use solvent to clean the inside of the crankcase breather tube, and dry with compressed air.

Inspect

1. Use air pressure to blow through the vent tube.
2. Replace the vent tube if it is clogged.

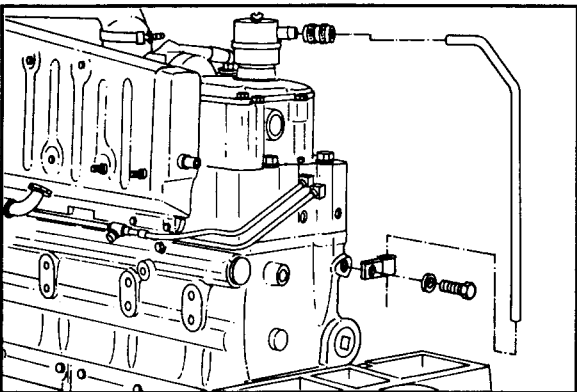

Install

1. Install the vent tube, the hose, the hose clamps, the brackets, and the capscrews on the engine.
2. Tighten the capscrews to 25 N•m [20 ft-lbs] torque.
3. Install the hose on the breather, and tighten the hose clamps to 5 N•m [40 in-lbs] torque.

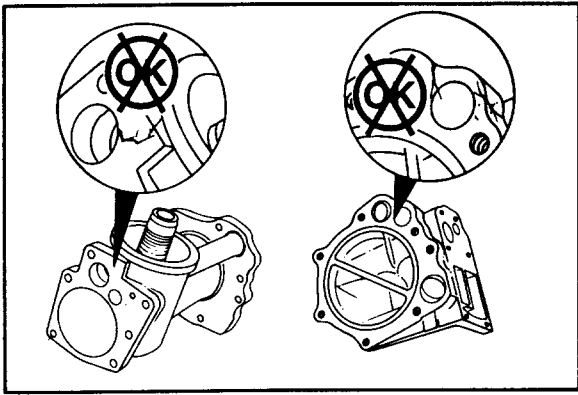

3. Visually inspect the filter head and the housing for cracks or other damage.

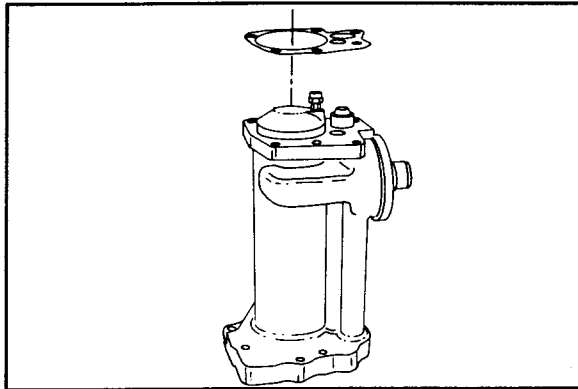

Install

1. Install a new oil cooler cover gasket on the cooler housing. Align the holes in the gasket with the holes in the housing.

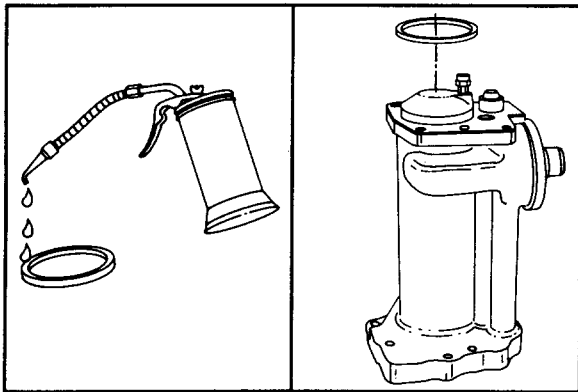

2. Lubricate the rectangular sealing ring with vegetable oil prior to assembly.
3. Install the rectangular sealing ring over the end of the cooler core. Make sure the ring fits tightly against the gasket.

NOTE: Do not use lubricating oil on the rectangular sealing ring. The sealing ring will increase in size when in contact with lubricating oil. Use vegetable oil to lubricate the sealing ring.

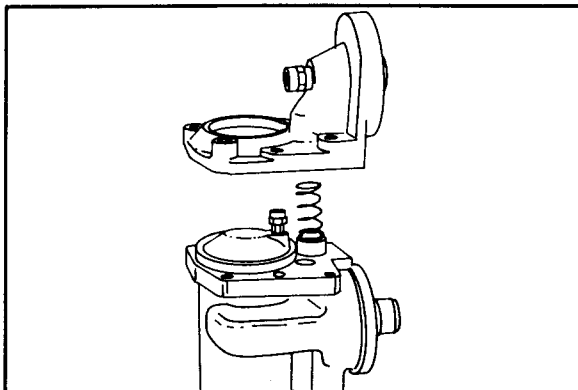

4. Install the compression spring on top of the pressure sensing piston.
5. Install the bypass filter head over the end of the cooler element. Make sure the compression spring is located in the filter head bore.

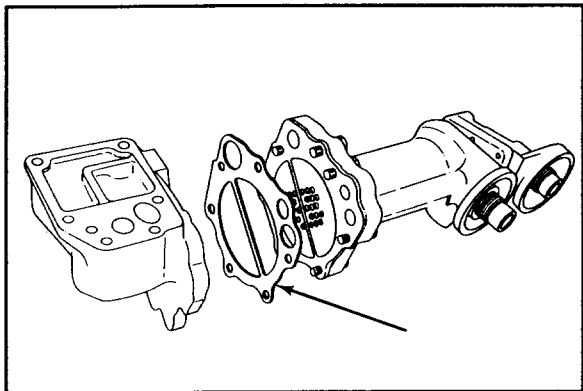

17. Install the capscrews through the cooler housing, and install the gasket over the capscrews.
18. Tighten the six capscrews to 45 N•m [35 ft-lbs] torque.

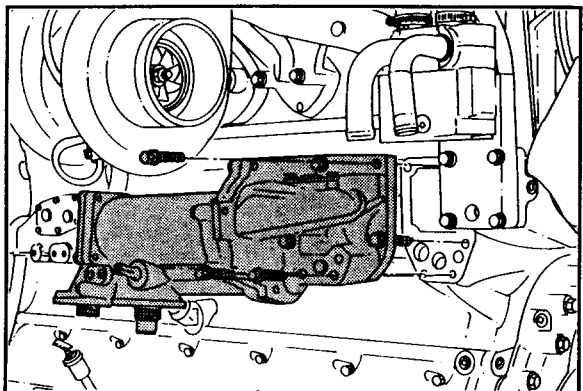

19. Install the oil cooler assembly. Refer to Procedure 2-19.

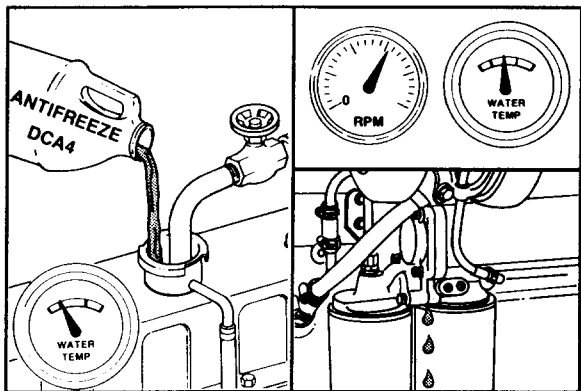

20. Fill the cooling system. Refer to Procedure 1-07.
21. Operate the engine until the water temperature reaches 80°C [180°F], and check for coolant or oil leaks.

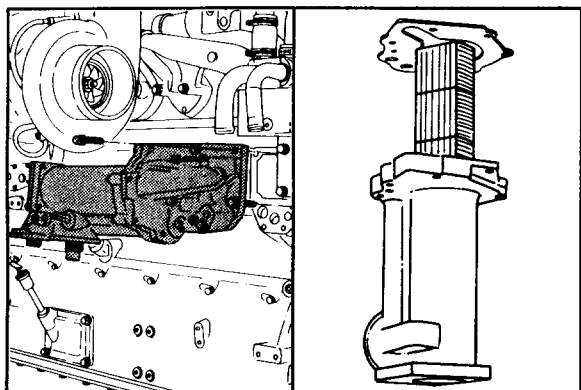

Oil Cooler Core - Pressure Test (2-21)

1. Remove the oil cooler assembly. Refer to Procedure 2-19.
2. Remove the oil cooler core. Refer to Procedure 2-20.

High Oil Pressure Relief Valve - Check (2-26)

Check Retainer Plug Depth



1. Remove the lubricating oil pump. Refer to Procedure 2-25.
2. Remove the lubricating oil pump cover.

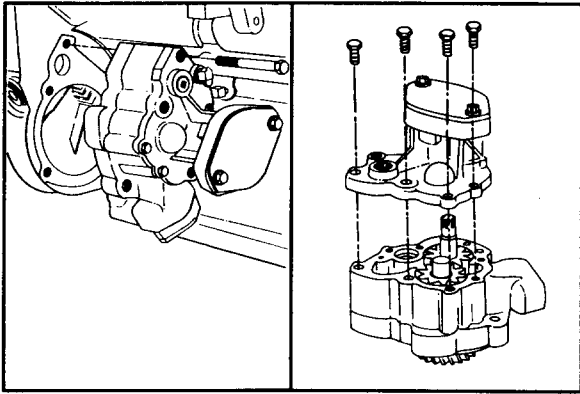

3. Remove all gasket material from the lubricating oil pump body and cover.

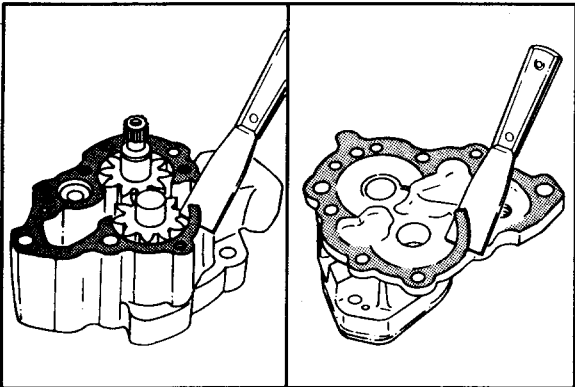

4. Measure the installed depth of the retainer plug.



5. If the plug depth is less than 6.48 mm [0.255-inch], use Part No. 3376011 DFC Pressure Valve Fixture to install it to the correct depth of 6.48 to 6.98 mm [0.255- to 0.275-inch].

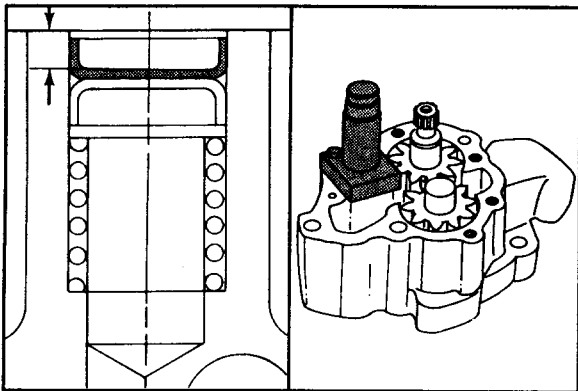

NOTE: If the plug depth is within specifications and the engine oil pressure is out of specifications, check the high oil pressure relief valve and the main oil pressure regulator. Refer to Procedures 2-27 and 2-22, respectively.

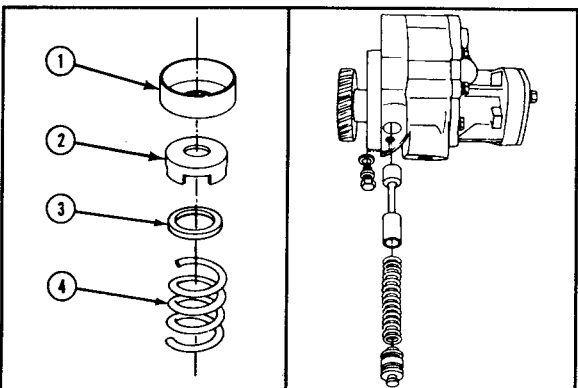

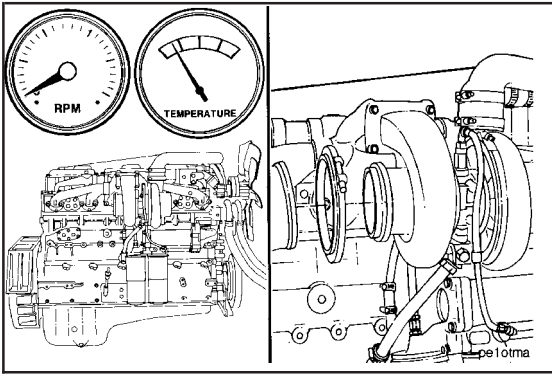

3. Shut off the engine.
4. Allow the turbocharger to cool, and remove the exhaust pipe from the turbine housing.

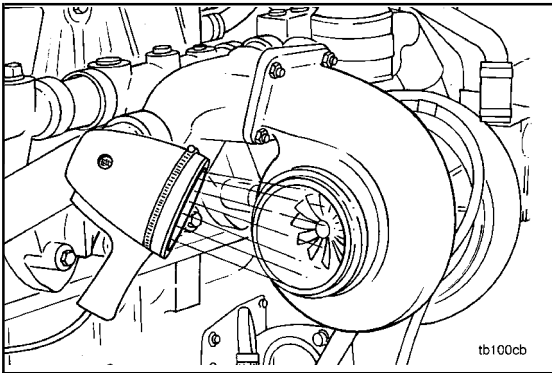

5. Use a high intensity black light (Part No. 3377253 or 3377394) to inspect the turbine outlet for oil.



NOTE: A dark blue glow indicates fuel, and a yellow glow indicates oil. Refer to Procedure 5-13.

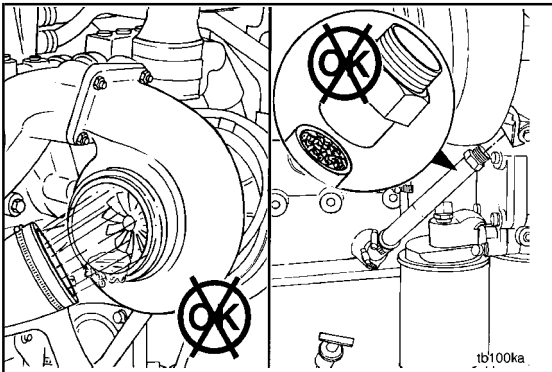

6. If oil is found on the turbine housing, remove the oil drain tube and check for restrictions. Clear any restrictions found or replace damaged component as required.

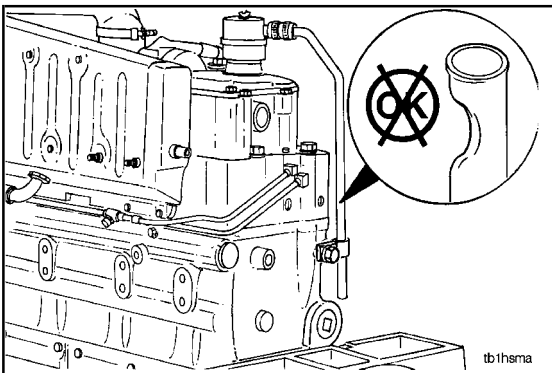

7. If no drain tube restriction is found, check for restrictions in the engine breather or the breather tube. Clear any restrictions found or replace damaged component as required.

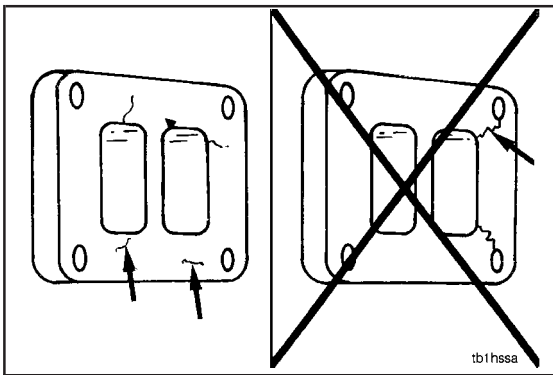

3. Cracks on the turbocharger mounting flange **must not** reach the mounting holes.

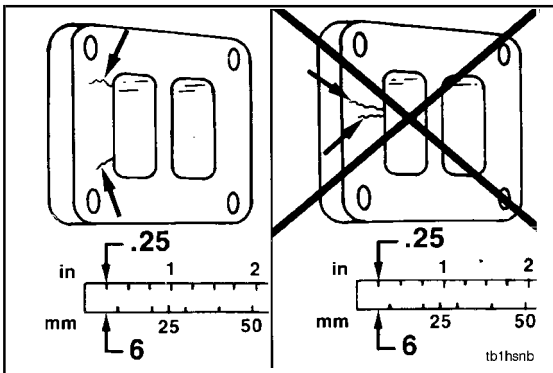

4. Two cracks on the turbocharger mounting flange **must** be separated by 6.4 mm [0.25 inch].

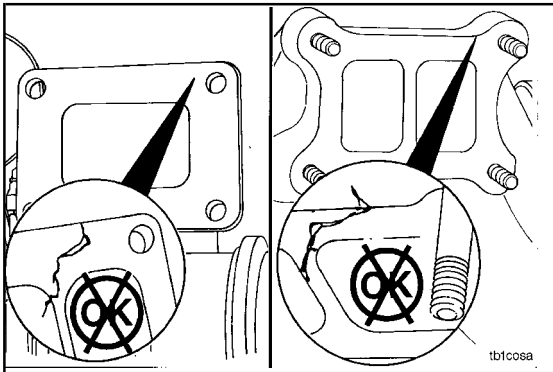

5. Visually inspect the exhaust manifold gasket surfaces and the mounting studs for cracks or damage.
Replace any cracked manifolds or damaged mounting studs.

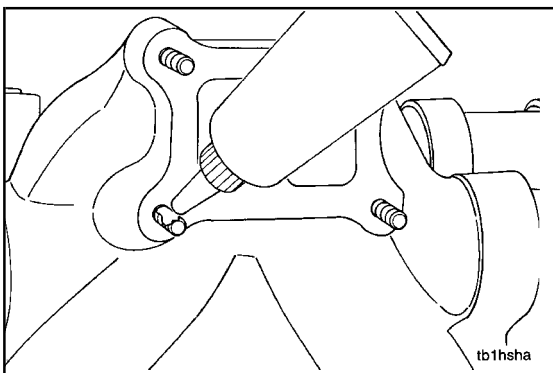

Install the Single Stage Turbocharger

1. Apply a film of high temperature anti-sieze compound to the turbocharger mounting studs.

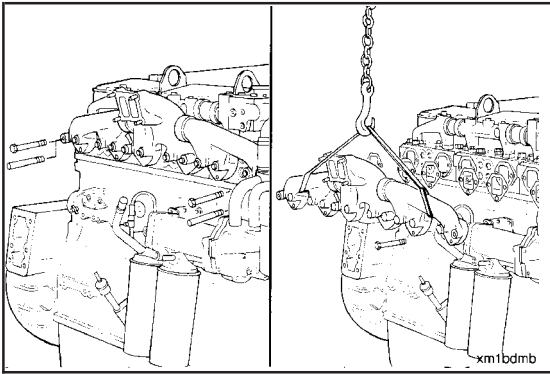

3. Remove the two capscrews, and install two guide studs.



Warning: Because this assembly weighs more than 23 kg [50 lbs], two people or a hoist will be required to lift the exhaust manifold assembly to avoid personal injury.



4. Remove the remaining ten capscrews, the exhaust manifold assembly, and the manifold gaskets.

NOTE: Two dowels are used in each cylinder head to align the exhaust manifold assembly.

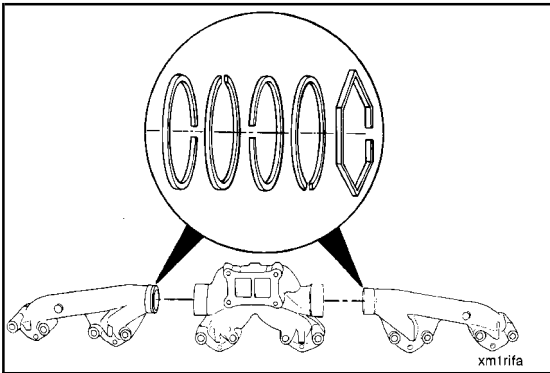

Disassemble

1. Remove the exhaust manifold end sections.
2. Remove the seal rings and the seal ring expander, if used.

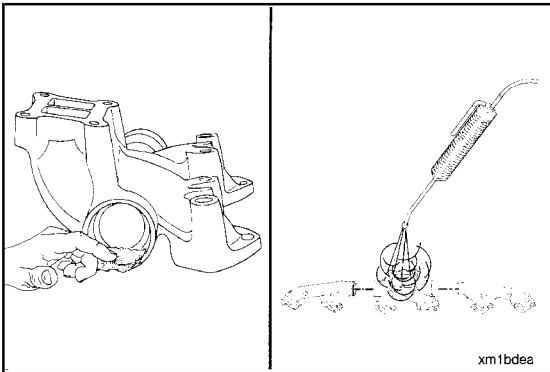

Clean and Inspect

1. Use a 240 grit emery cloth to remove carbon deposits from the sealing surfaces and the seal ring grooves.
2. Steam clean, and dry with compressed air.

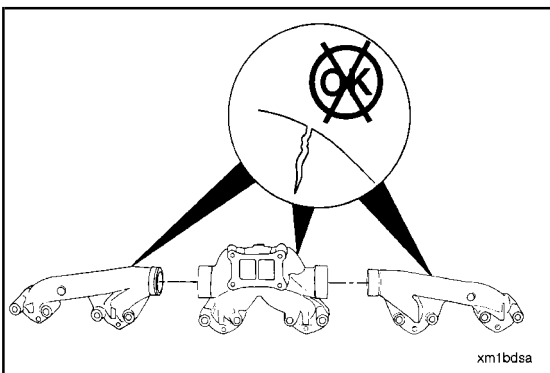

3. Visually inspect for cracks or damage.
4. Visually inspect the manifold seal bore and the mating sealing ring surface for wear.



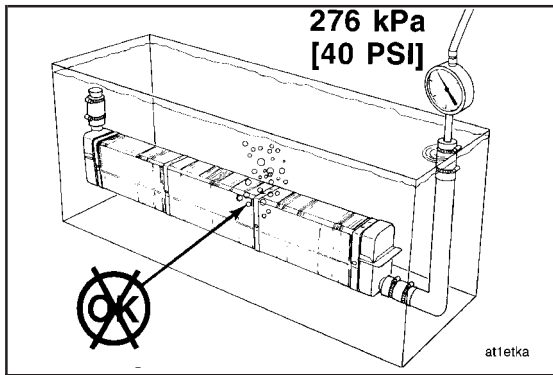

6. Connect the air pressure gauge to a regulated air supply, and apply 276 kPa [40 psi] air pressure.
7. Submerge the core or aftercooler assembly in a tank of water heated to 80°C [180°F].
8. If air bubbles appear, the core is damaged. Replace the core or aftercooler assembly.

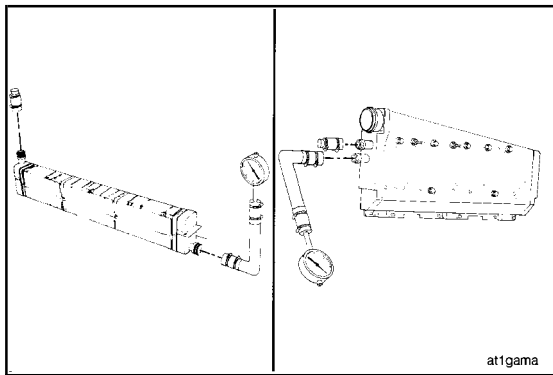

9. Remove the core or aftercooler assembly from the water tank.
10. Remove the test equipment.

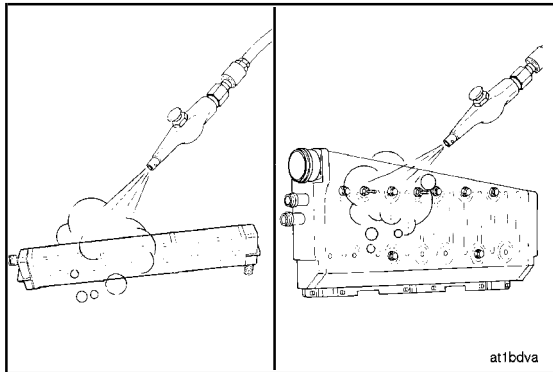

11. Dry with compressed air.

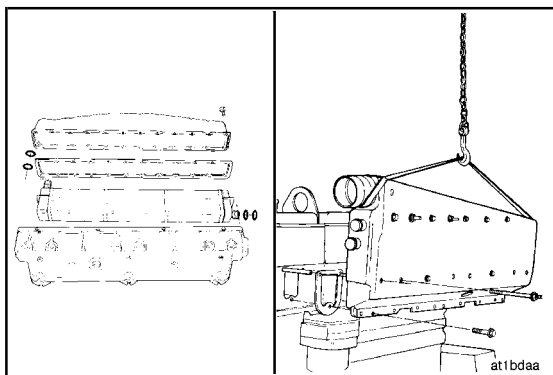

12. Assemble the Big Cam III aftercooler. Refer to Procedure 3-16.
13. Install the aftercooler assembly. Refer to Procedure 3-16.

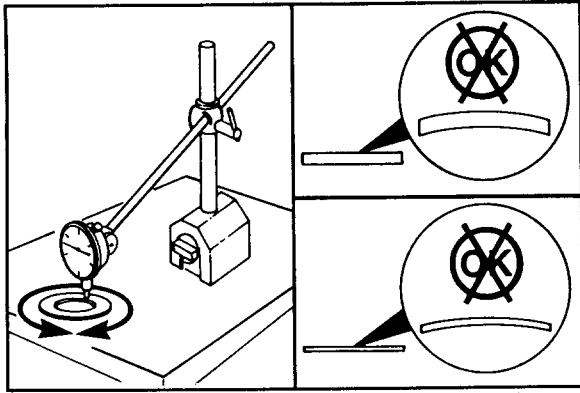

- i. Measure the flatness of the intake and exhaust valves. Both valves **must** be flat within 0.03 mm [0.001 inch].

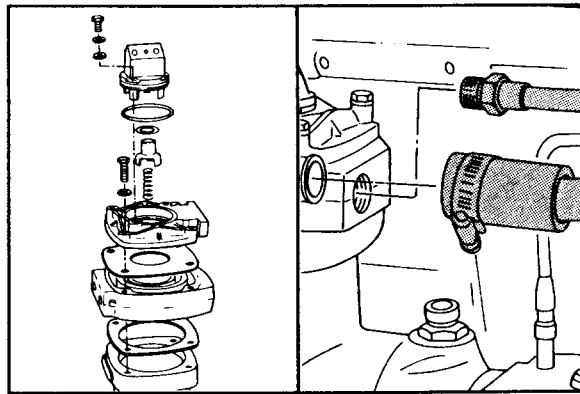

- 5. Assemble the air compressor using new gaskets and O-rings. Refer to Procedure 4-11.
- 6. Install and tighten the air inlet and outlet connections.

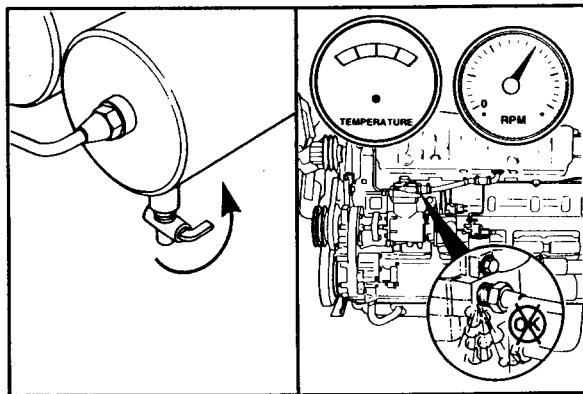

- 7. Close the "wet tank" draincock.
- 8. Operate the engine and check for air leaks.

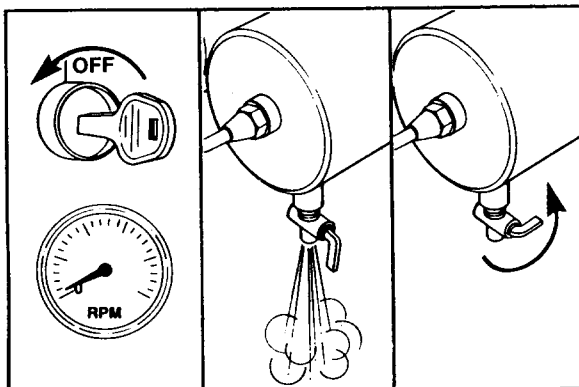

Gasket Leaks, Air Compressor - Check (4-06)

NOTE: The illustrations shown will be of the single cylinder air compressor. Differences in procedures for one and two cylinder Cummins air compressors will be shown where necessary.

- 1. Shut off the engine.
- 2. Open the draincock on the "wet tank" to release air pressure from the system; then close after pressure is released.

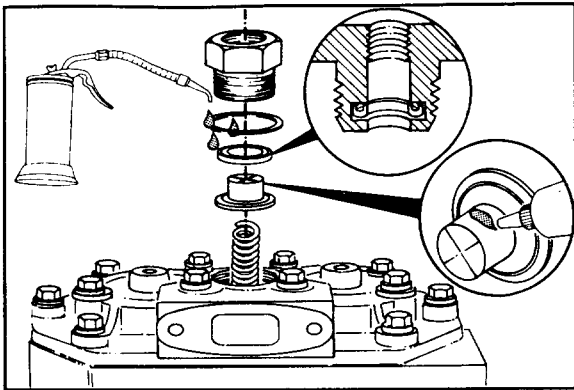

NOTE: For Cummins two cylinder air compressors, complete steps 13 through 19 to install the center unloader valve assembly before the cylinder head capscrews are tightened.

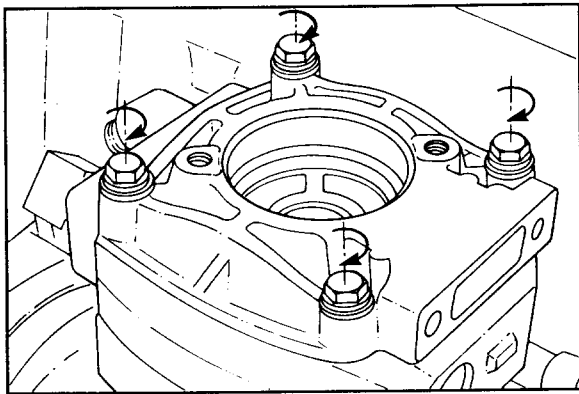

9. Tighten the cylinder head capscrews of the single cylinder compressor in alternating sequence to the following torque values:

- a. 7 N•m [60 in.-lb]
- b. 15 N•m [10 ft-lb]
- c. 20 N•m [15 ft-lb]
- d. 25 N•m [20 ft-lb]

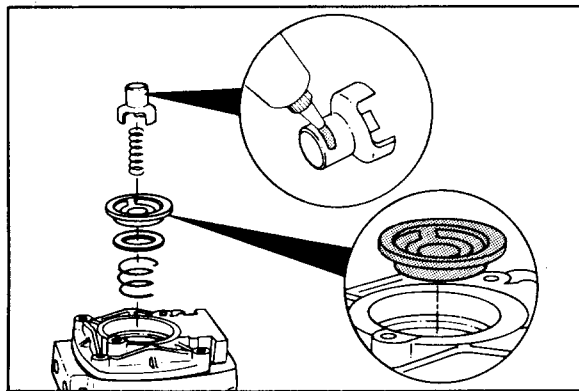

10. Install the intake valve spring as shown.

11. Install the intake valve.

12. Install the intake valve seat with the flange side up as shown.

13. Install the unloader valve cap spring.

14. Install the unloader valve cap.

15. Use anti-seize compound to lubricate the outside diameter of the cap.

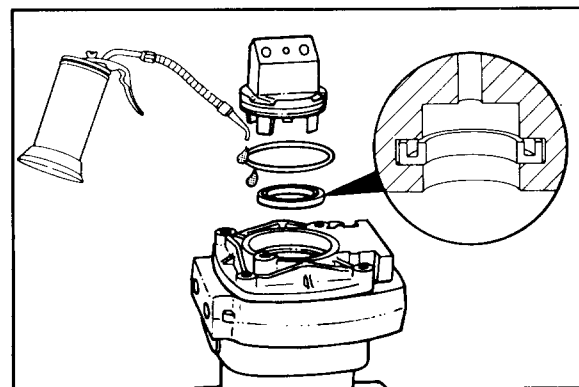

Caution: The rectangular ring seal must be installed with the grooved side up.

16. Install the rectangular ring seal as shown.

17. Install the O-ring seal.

18. Use clean engine oil to lubricate the O-ring seal.

Caution: Press the unloading valve body down to be sure the tangs of the unloader valve cap are in the three slots of the intake valve seat.

19. Install the unloading valve body.



Air Connection Check Valve Installation

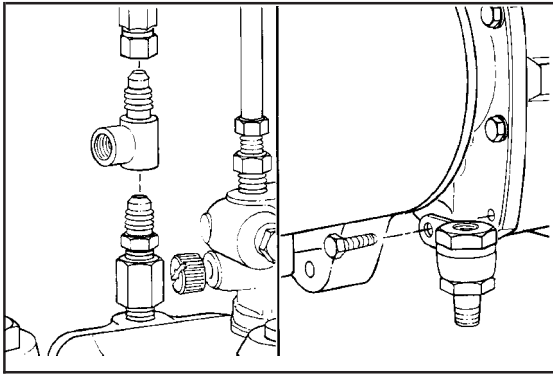

1. Install a pipe tee in the AFC air connection in the AFC cover.
2. Install the pipe clamp that holds the check valve on the lower front cover capscrew.

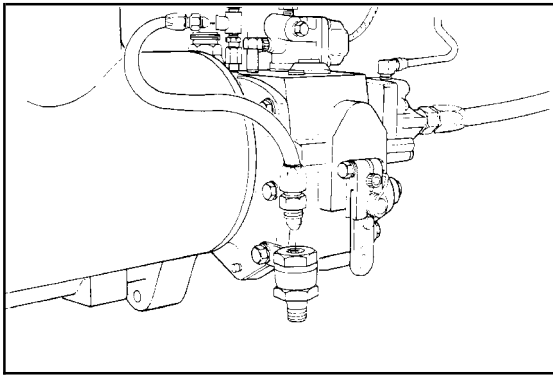

3. Install a No. 4 hose between the tee and the valve.

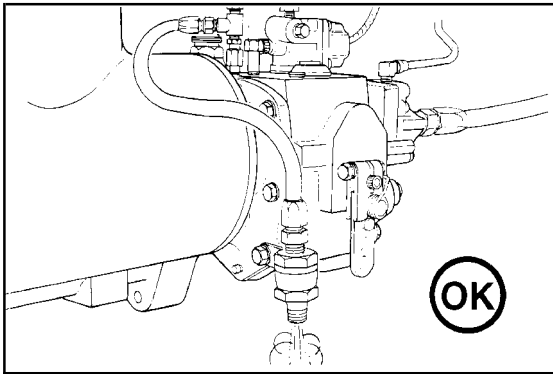

4. When the engine is operating, a small amount of air (turbocharger pressure) will come out of the bottom of the valve.

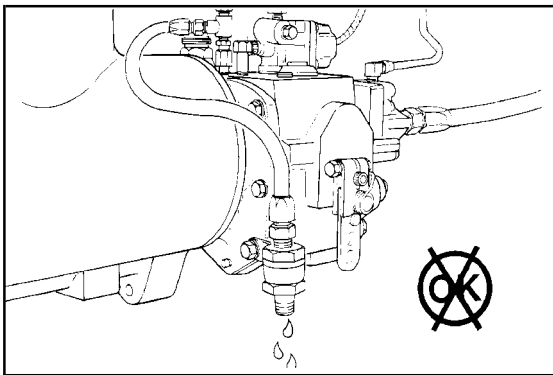

5. If the AFC bellows fails, fuel will drain out of the valve.

Fuel Pump Adjust (5-05)

Idle Speed - Adjust

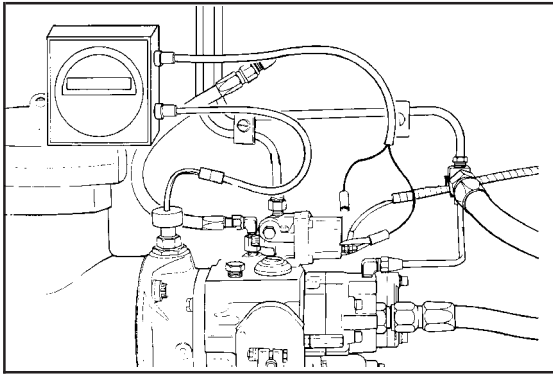

1. To check the engine speed, use the vehicle tachometer, Part No. ST-744 Hand Tachometer, Part No. 3375631 Digital Tachometer, or Part No. 3377462 Optical Tachometer.

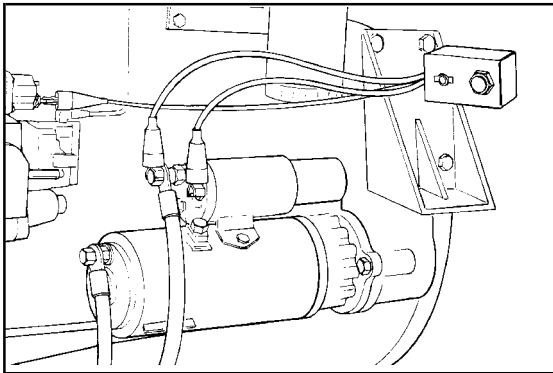

2. The remote starter, Part No. 3376506, can be used to start the engine. The leads are marked for their connection points.

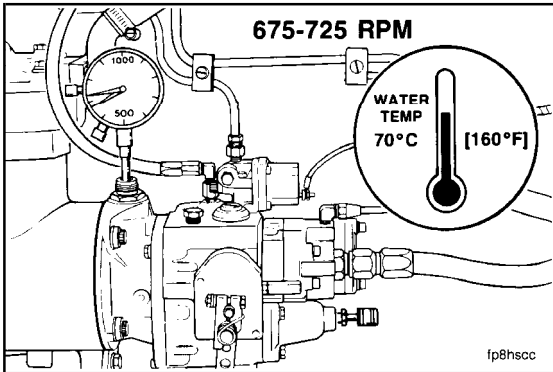

3. Adjust the engine low idle speed between 650 to 725 RPM.

NOTE: This adjustment is sometimes necessary on a new engine to compensate for the added engine driven accessories that are installed by the truck or vehicle manufacturer.

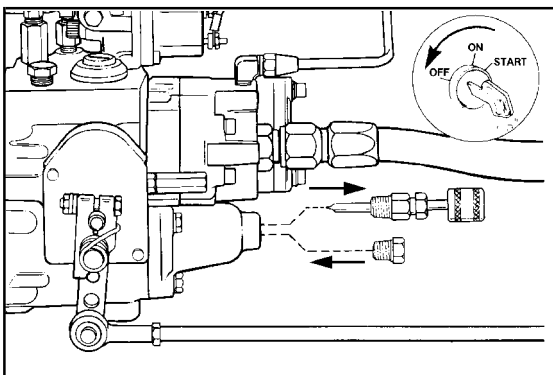

4. Stop the engine.
5. Remove the plug from the spring pack cover.
6. Install the fuel pump idle adjusting tool, Part No. 3375981, in the plug hole.

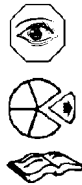
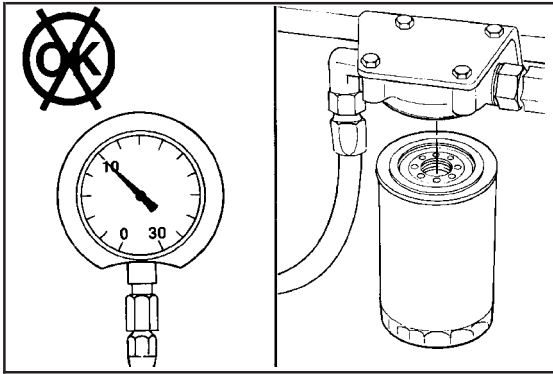

8. If the gear pump fuel inlet restriction is high, replace the fuel filter. Refer to Procedures 5-08 and 5-15.

1 Pump Code	4147-C	
2 Date - Control Parts List	JUN85 0676	
3 Test H.P. @ R.P.M.	392 - 408 @ 2100	←←
4 Engine Fuel P.S.I.	172 - 190	
5 Torque Rise % Curve	25	
6 No Air Snagral P.S.I.	-	
7 Fuel Rate Pound Per Hour	-	←
8 Auto. Gov. Setting	2130 - 2150	
9 V.S. Gov. Setting	-	
10 Max. Gov. Check R.P.M.-P.S.I.	2457 - 15	
11 Throttle Leakage - Cc-Pph	110	
12 Throttle Travel	28	
13 Idle Speed P.S.I. @ R.P.M.	36 @ 500	
14 Idle Speed C.C. @ R.P.M.	210 @ 630	
15 Intake Mtd. Press. In./Hg.	46 - 54	
16 Calibration P.S.I. @ R.P.M.	181 @ 2100	←
17 Calibration Flow	505	
18 Check Point (1) P.S.I. @ R.P.M.	117 - 125 @ 1300	
19 Check Point Flow	401	
20 Check Point (2) P.S.I. @ R.P.M.	- @	

OK



9. If all of the values are within the specifications, the engine is producing the correct horsepower.

SYMPTOM: LOW POWER	
Cause	Correction
Vehicle Overloaded	Reduce vehicle load or use lower gear.
OK ↓	
Low Power Due to Altitude	Derate engine above 3600 meters (12,000 feet). Refer to page 5-3.
OK ↓	
Fuel Suction Line or Fuel Filter Restricted	Check fuel inlet restriction. Refer to page 5-55.
OK ↓	
Lubricating Oil Level Too High	Check dipstick calibration and oil pan capacity. Refer to pages 2-24 and 2-3.



10. If the values are **not** within the specifications, refer to the Low Power Troubleshooting Charts.

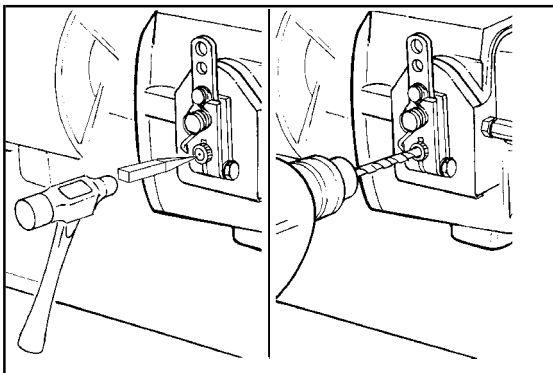

Fuel Rate - Adjust

- To raise or lower the engine fuel rate, remove the ball from the end of the throttle shaft.
 - Use a center punch to mark the ball.
 - Drill a 4 mm [0.1875 inch] (3/16 inch) hole in the ball.

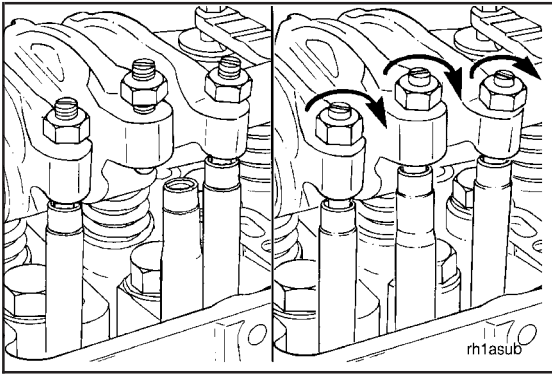

9. Turn the adjusting screw for the injector rocker lever in until it is properly seated in the push rod socket.
10. Adjust all crossheads, valves, and injectors. Refer to Procedure 7-04.

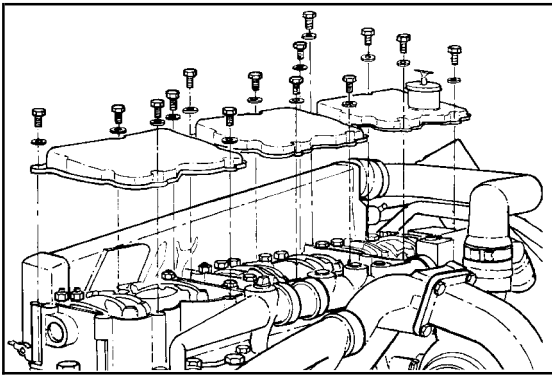

11. Install the rocker lever cover. Refer to Procedure 7-02.

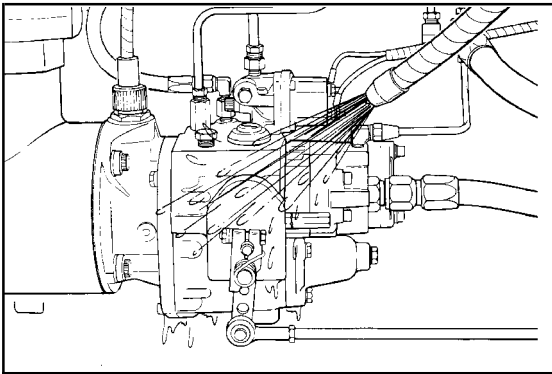

Fuel Pump - Replace (5-07)

Remove

1. Clean the fuel pump and the surrounding area before removing it from the engine.

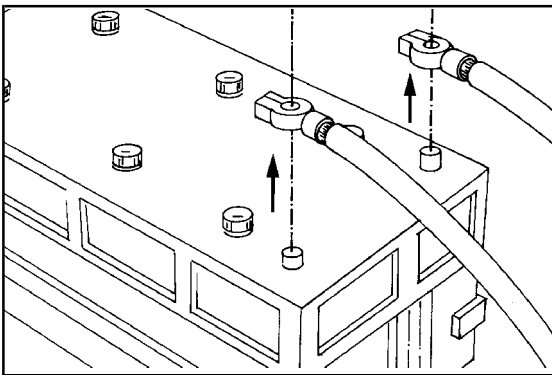

2. Disconnect the battery cables.

CLICK HERE TO **DOWNLOAD** THE COMPLETE MANUAL

- Thank you very much for reading the preview of the manual.
- You can download the complete manual from: www.heydownloads.com by clicking the link below



- Please note: If there is no response to CLICKING the link, please download this PDF first and then click on it.

CLICK HERE TO **DOWNLOAD** THE COMPLETE MANUAL

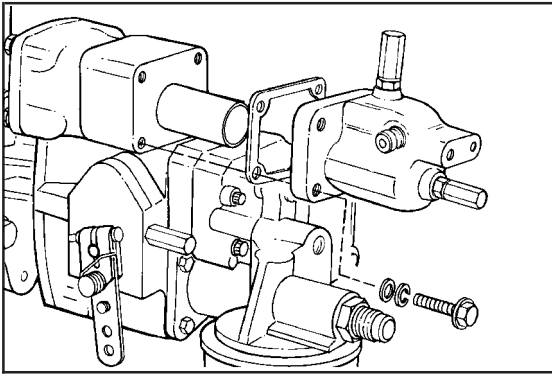

2. Remove the VS spring pack housing cover.

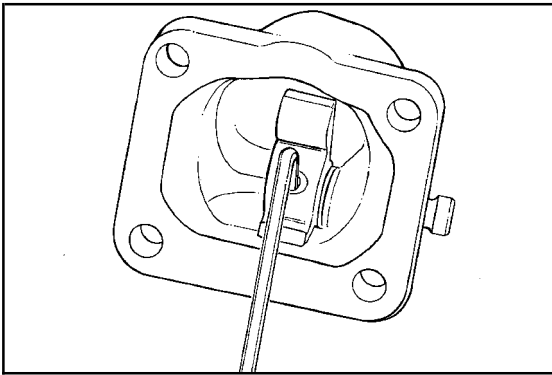

3. Loosen the set screw in the VS throttle stop.

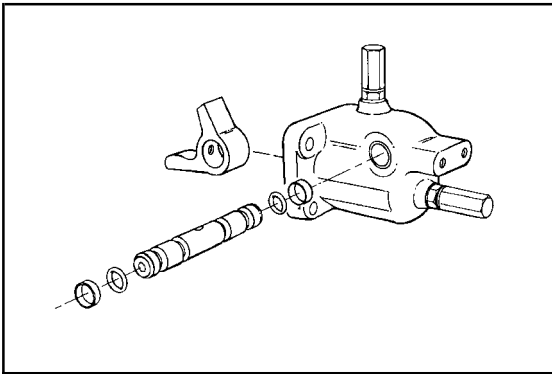

4. Remove the VS throttle shaft from the cover. Discard the O-rings.

5. Remove and discard the shaft dust seals from the cover.

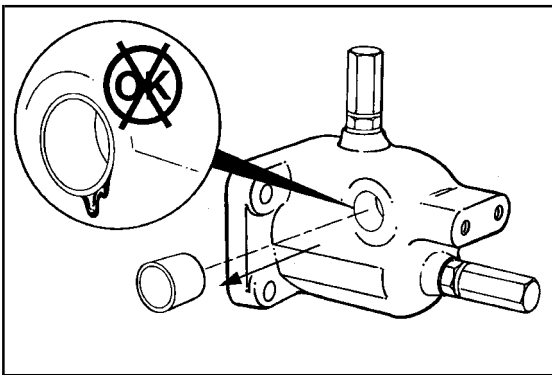

6. If fuel is leaking between the bushings and the cover, replace the bushings.

a. Press the bushings from the cover.

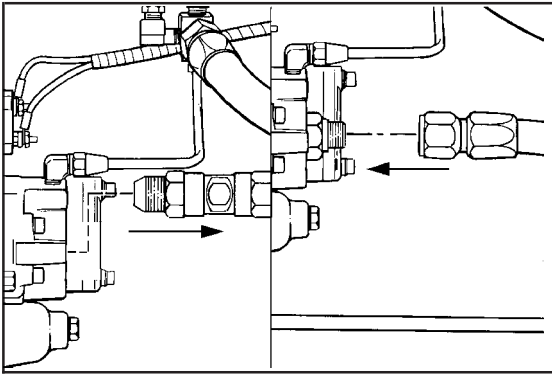

6. Remove the sight glass and install the suction hose.
7. Test the engine again for other fuel leaks.

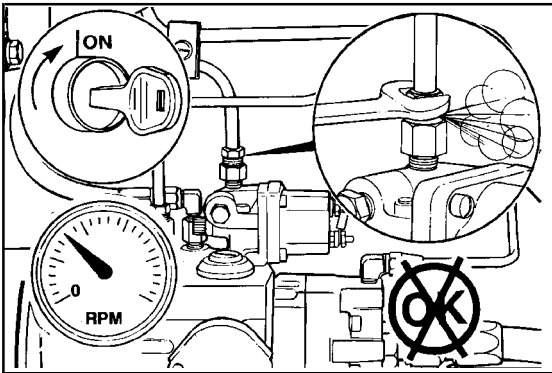

Air Leak In Fuel Pump - Check

1. Operate the engine to create pressure in the fuel lines.
2. Loosen the fuel outlet line at the shutoff valve to remove the air from the fuel pump.

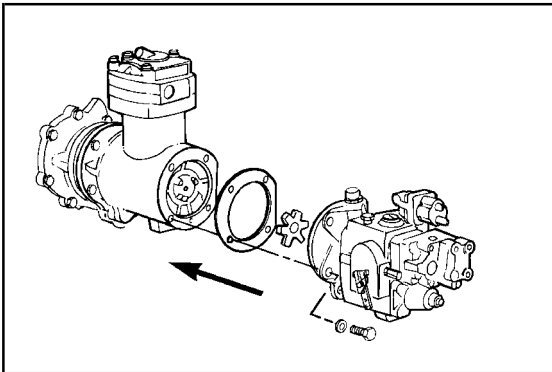

3. If the air flow continues, remove and repair the fuel pump. Refer to Procedure 5-07.

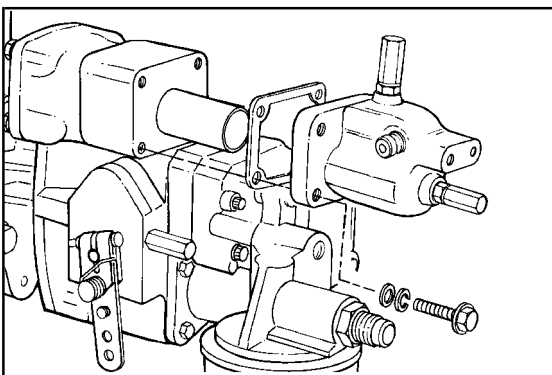

Air Leak In Road Speed Governor - Repair

1. Remove the air tube.
2. Remove the road speed governor cover.

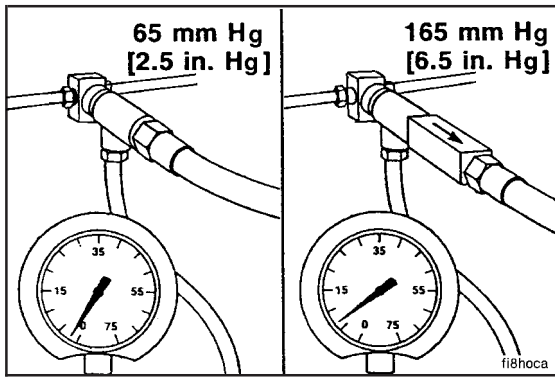

3. Observe the reading on the gauge. Hold the gauge at the same level as the connection.

NOTE: The maximum drain line restriction is as follows:

Without Check Valves	With Check Valves
65 mm Hg. [2.5 in. Hg.]	165 mm Hg [6.5 in. Hg.]

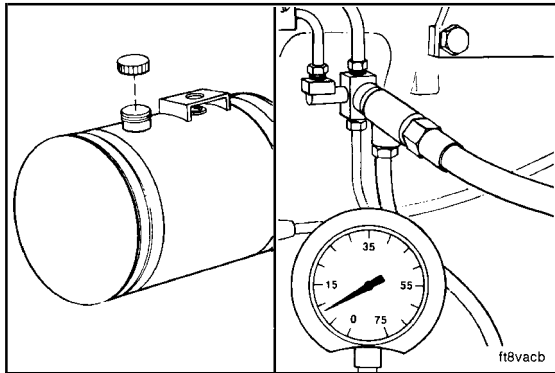

4. If the restriction is above the specifications, remove the fuel tank fill cap and check again.

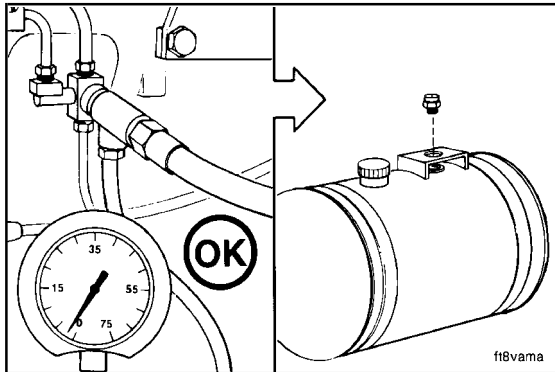

5. If the restriction is below the specifications when the cap is removed, replace the tank vents.
6. If the restriction is still above the specifications, inspect the drain lines.

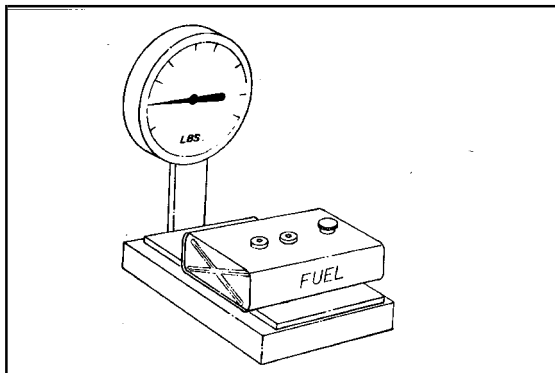

Fuel Consumption Check (5-16)

Refer to the fuel consumption check list sheets in the back of this chapter.

The most accurate method to check the fuel consumption is to weigh the fuel used.

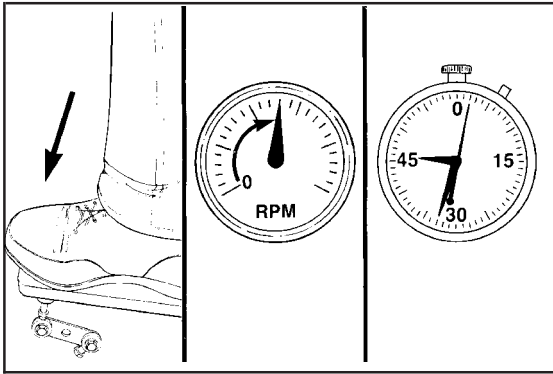

12. Accelerate the throttle to the wide open position and use a stop watch to check the time.

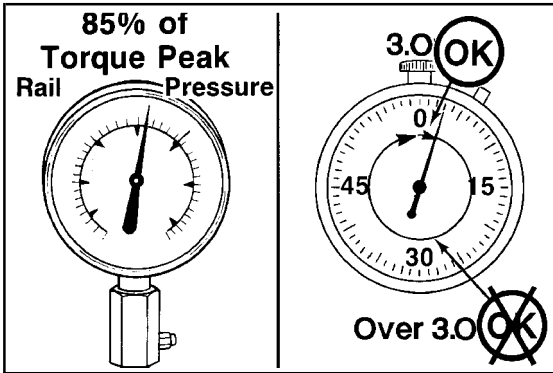

13. When the engine reaches target rail pressure, stop the stop watch.

14. The acceptable response time range is 3.5 seconds or less on engines built after January 1, 1984.

NOTE: The specifications are **not** available for engines built before January 1, 1984.

15. If the response time is over 3.5 seconds, refer to the "Throttle Response Slow" troubleshooting chart.

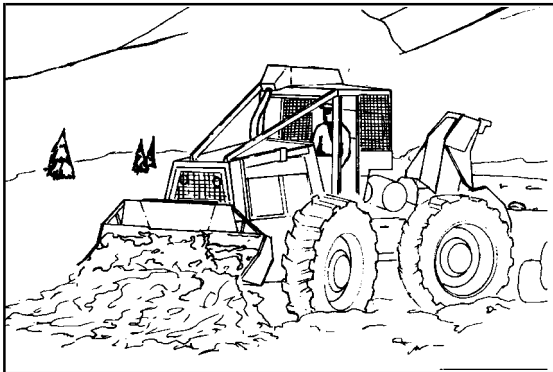

Engine Stall Speed And Time Check (5-19)

Converter Transmissions Stall Speed Check

1. The stall speed is the engine speed (RPM) obtained at full throttle when the converter output shaft is locked.
 - a. The vehicle brakes may **not** hold an electronically controlled transmission.

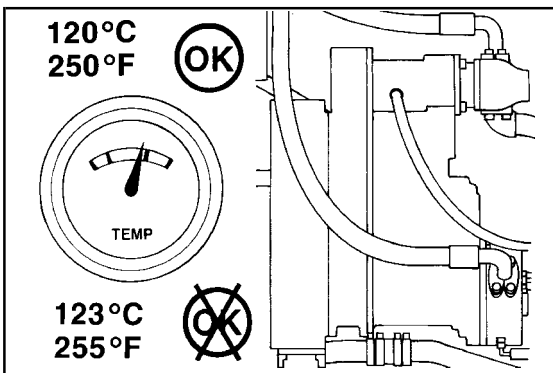

Caution: Do not exceed 120°C [250°F] converter oil temperature. If the oil temperature exceeds 120°C [250°F], put the transmission in neutral and operate the engine until the oil temperature is below 120°C [250°F]. Check the converter oil level.

Fuel Consumption Check List (Vehicle Factors)

Engine versus vehicle specification can be based upon economy or fast trip schedules which will **not** produce what the owner desires. An analysis can often point out a compromise to more closely fit the current requirements.

_____	Engine Rated Speed	_____	Horsepower
_____	Type Trailer	_____	
_____	Type Tires		
_____	Bias	_____ Std. Tread	_____ Extra Tread
_____	Radial	_____ Std. Tread	
_____	Axle	_____ Single	_____ Dual
_____	Axle Ration	_____	
_____	Transmission	_____	
_____	Gross Vehicle Weight	_____	
_____	Wind Deflectors	_____ Yes	_____ No
_____	Pavement Operated On	_____	
_____	Fan Drive	_____ Full Time	_____ Variable
_____	Freon Compressor	_____ Yes	_____ No
_____	Power Steering	_____ Yes	_____ No
_____	Axle Alignment	_____ Recent	_____ Never
_____	Fuel Line Leaks		
_____	Fuel Tank Vents		
	(Must not pressurize tank above 65 mm Hg [2.5 inch/mercury])		
_____	Brake Drag		

This Page Can Be Copied For Your Convenience.

3. Turn the starter switch to the "START" position.
4. The multimeter **must** indicate system voltage.

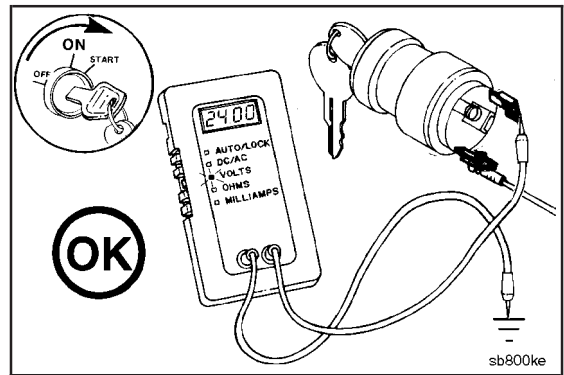

5. If there is no voltage:
 - a. Turn the starter switch to the "OFF" position.
 - b. Connect the multimeter positive lead to the starter switch terminal having a wire connecting the starter switch to the starter solenoid.

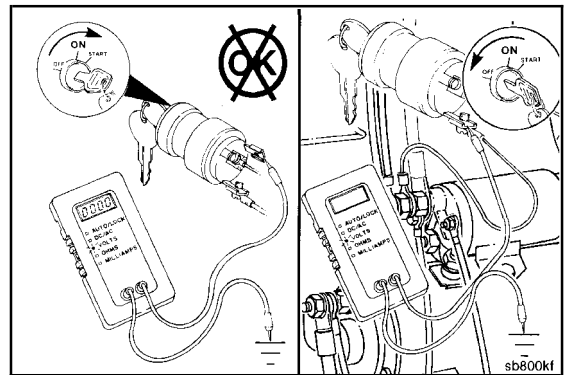

6. If the meter indicates system voltage, the starter switch is defective and **must** be replaced.

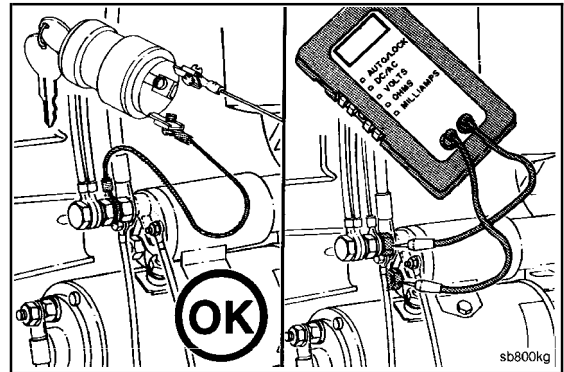

7. If the meter indicates no voltage, the switch is **not** the cause of the complaint.

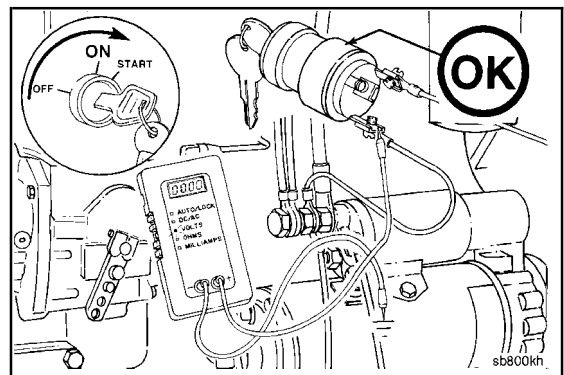

	Procedure No.	Page No.
Vibration Damper	7-29	7-
Wear Sleeve, Accessory Drive Pulley - Replace	7-26	7-

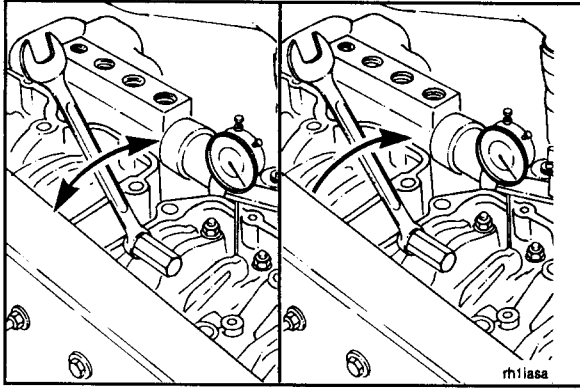

Warning: The injector plunger is under spring tension. Do not allow the tool to slip. Personal injury can result.

14. Actuate the injector rocker lever several times. Allow the lever to return slowly to prevent damage to the dial indicator. Hold the injector plunger to the bottom of its travel, and confirm the "0" (zero) reading on the dial indicator.

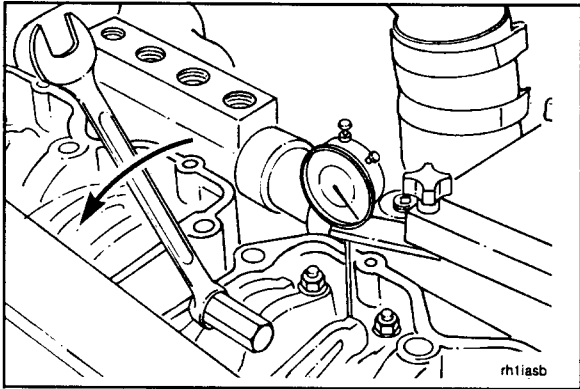

15. Allow the injector rocker lever to return slowly. Check the reading on the dial indicator. Repeat the adjustment process if the reading is **not** within specifications.

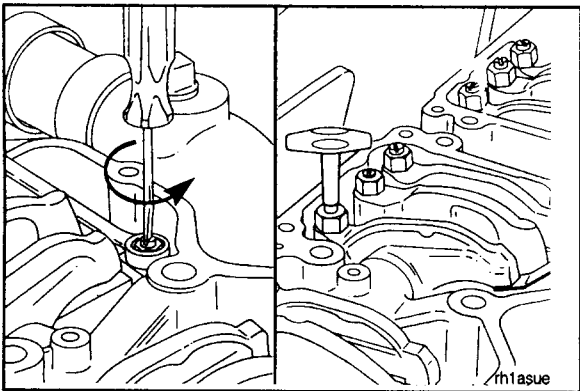

16. Adjust the crossheads and the valves on cylinder No. 5 **before** rotating the accessory drive to the next valve set mark. Refer to "Crosshead Adjustment" and "Valve Adjustment" in this Procedure.

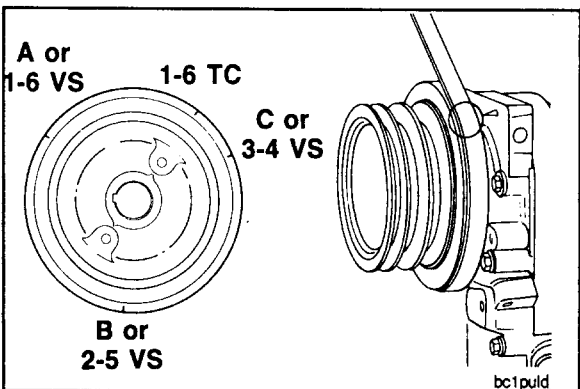

17. After adjusting the crossheads and the valves on cylinder No. 5, rotate the accessory drive; and align the next valve set mark on the accessory drive pulley with the pointer on the gear cover.

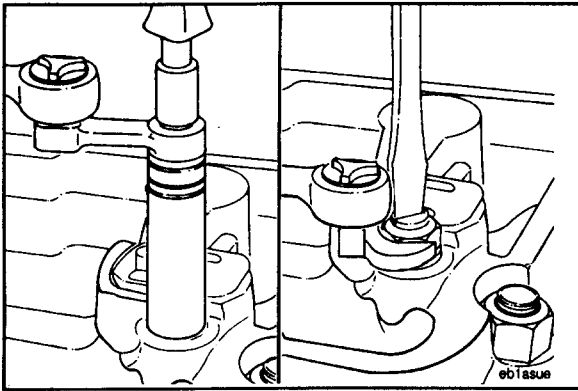

10. Hold the adjusting screw in position. The adjusting screw **must not** turn when the lock nut is tightened. Tighten the lock nut to the following torque values:

With Torque Wrench Adapter, 30 N•m [22 ft-lbs]
Part No. St-669 (1)

Without Adapter 35 N•m [25 ft-lbs]

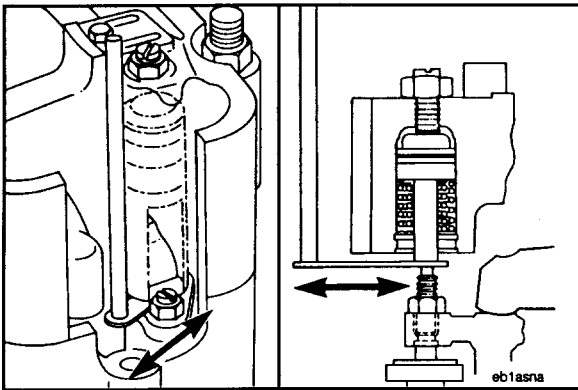

Caution: After the slave piston adjusting screw lock nut is tightened to the correct torque value, check the clearance with the feeler gauge again. Do not overtighten the adjusting screw lock nut. Too much torque on the lock nut can cause the reset mechanism in the slave piston adjusting screw to seize and will cause engine damage.

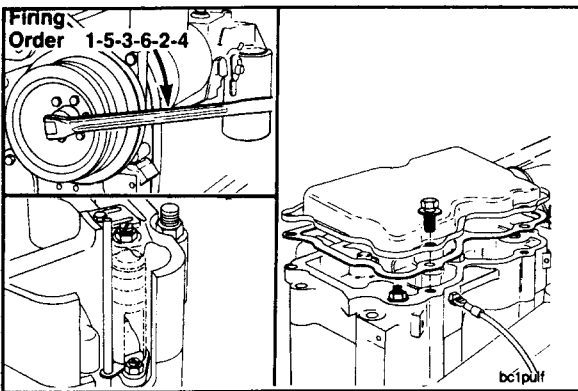

11. Continue to rotate the accessory drive in firing order rotation, and use this procedure to adjust all six slave pistons at the correct valve set positions.

12. Install the rocker housing cover(s). Refer to Procedure 7-02.

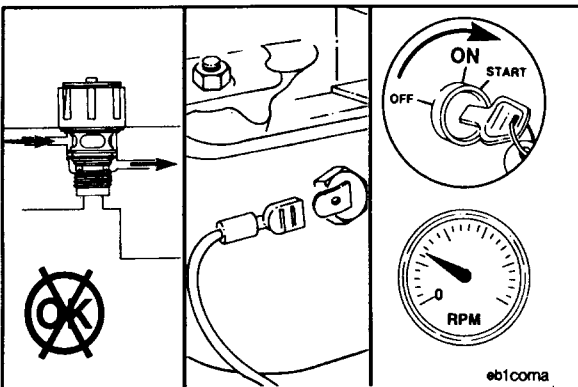

Jacobs® Engine Brake - Check (7-06)

An engine equipped with a Jacobs® Engine Brake may fail to start or perform correctly due to one or more of the following:

1. Engine will **not** start due to a stuck oil flow solenoid valve.

NOTE: To check for a stuck solenoid valve, do the following:

- a. Disconnect the electrical wires to the engine brakes, and operate the engine.

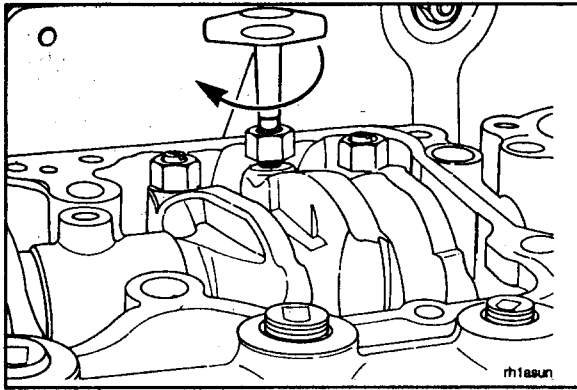

7. Adjust the valves and the injectors. Refer to Procedure 7-04.

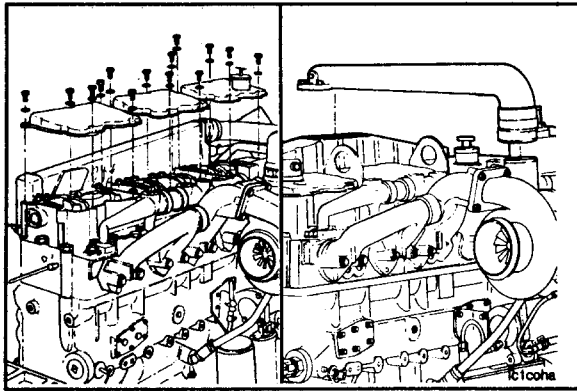

8. Install the rocker housing covers. Refer to Procedure 7-02.

9. Install the air crossover connection (Big Cam III only). Refer to Procedure 3-13.

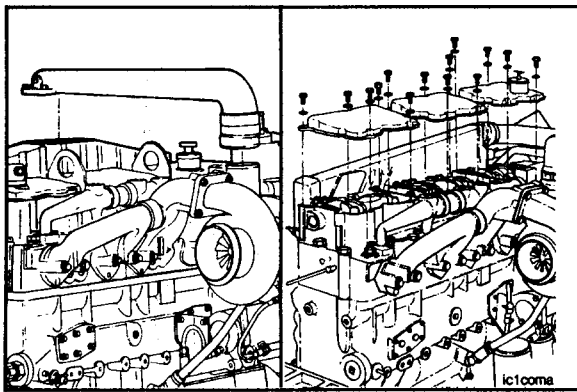

Rocker Levers/Rocker Lever Housings - Replace (7-09)

Remove

1. Remove the air crossover connection (Big Cam III only). Refer to Procedure 3-13.

2. Remove the rocker housing covers. Refer to Procedure 7-02.

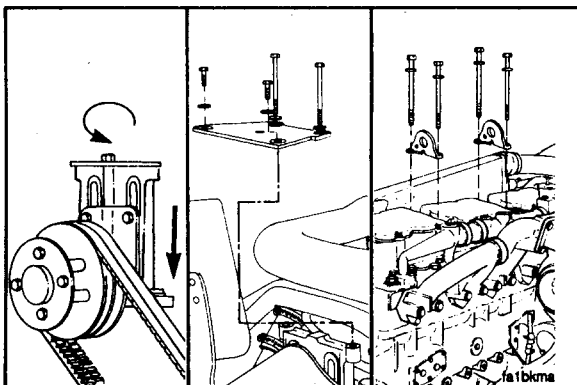

3. Release the fan drive belt tension. Remove the fan hub adjusting screw (Big Cam III only). Refer to Procedure 1-20.



4. Remove the aftercooler water transfer tube support bracket on Big Cam IV engines.



5. Remove the fan bracket brace between the fan bracket and the rocker housing.

6. Remove the engine lifting brackets.

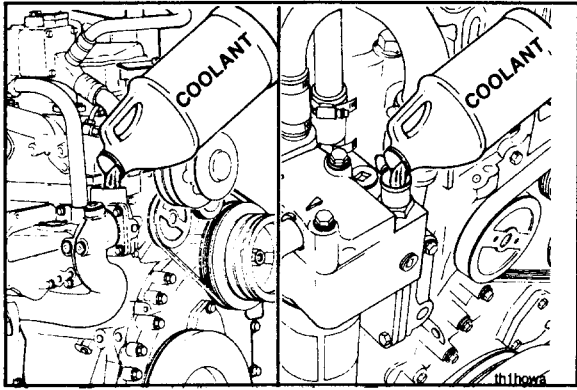

6. Fill the cylinder block with coolant at the following locations:
 - a. Coolant bypass hose (Big Cam III engines).
 - b. Engine fill line (Big Cam IV engines).

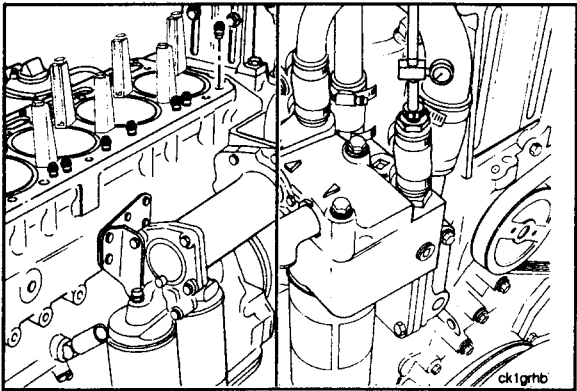

7. Install the remaining cylinder block water plug.

NOTE: Use shop air, a pressure regulator, and an adapter fabricated into a pipe plug or hose plug to apply air pressure to the cylinder block.



8. Install a plug with a shop air attachment in the bypass or coolant fill hose.

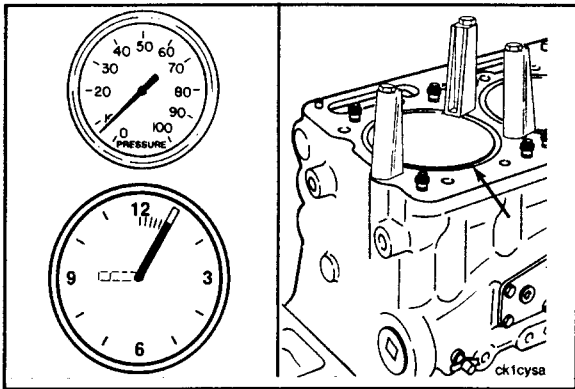

9. Apply 35 to 70 kPa [5 to 10 psi] air pressure to the cylinder block cooling system for 3 to 5 minutes.



10. Visually inspect between the cylinder liner flange and the cylinder block for coolant leakage.

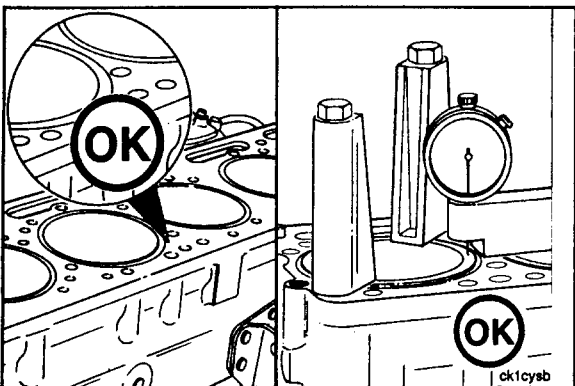

11. If no leakage is observed and the cylinder liner protrusion is within specifications, remove the cooling system plugs and the shop air.



12. Install a new head gasket(s), and replace the cylinder head(s). Refer to Procedure 7-11.



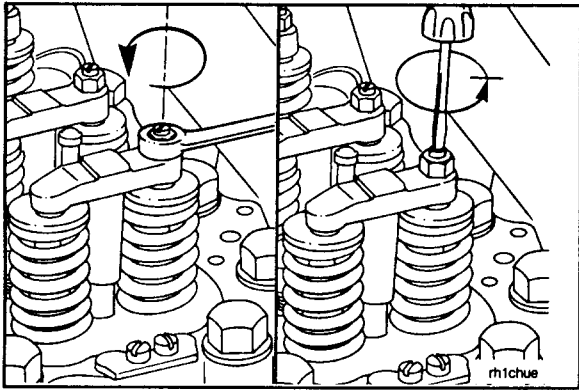

b. Install the crossheads on the crosshead guides with the adjusting screw toward the water manifold side of the engine.

NOTE: Engines with compression brakes use special crossheads on the exhaust valves.

c. Loosen the adjusting screw lock nut. Loosen the adjusting screw one full turn.

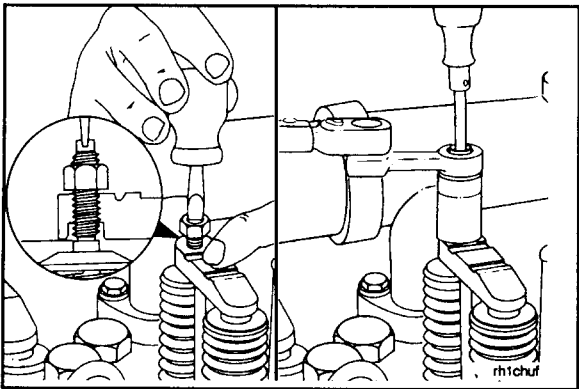

d. Use light finger pressure to hold the crosshead in position, and tighten the adjusting screw until it touches the top of the valve stem.

e. Hold the crosshead adjusting screw in position, and tighten the lock nut to 40 N•m [30 ft-lbs] torque.

NOTE: When ST-669 Torque Wrench Adapter is used, tighten the lock nut to 35 N•m [25 ft-lbs] torque.

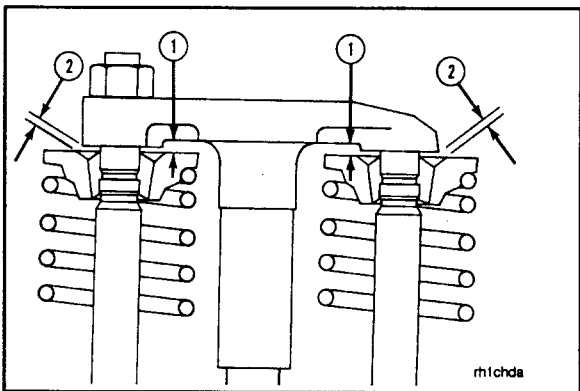

f. Use a wire gauge to check the clearance (1 and 2) between the crosshead and the valve spring retainer. The clearance **must** be a minimum of 0.65 mm [0.025-inch].

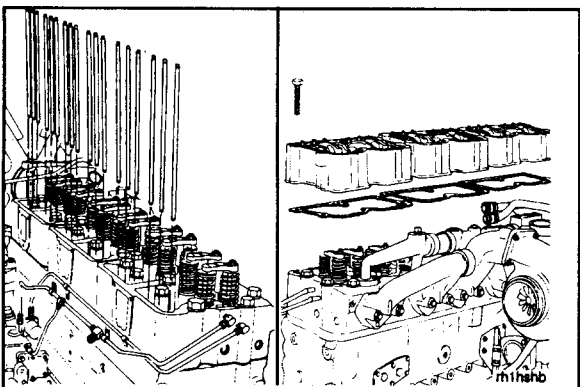

14. Install the push rods. Refer to Procedure 7-08.

NOTE: The injector push rods are larger in diameter than the valve push rods.

15. Install the rocker lever housings. Refer to Procedure 7-09.

16. Adjust the valves and the injectors. Refer to Procedure 7-04.

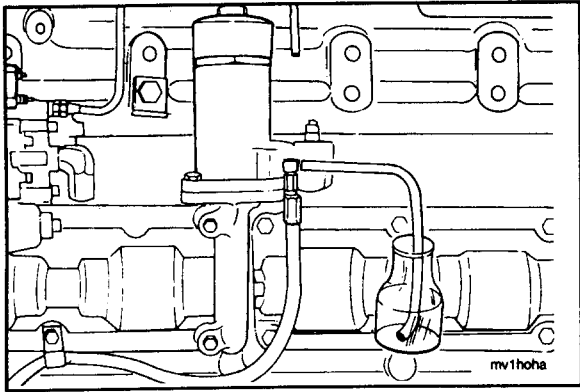

4. Attach a short piece of hose to the check valve.
5. Put the free end of the hose below the water level in a container of water.

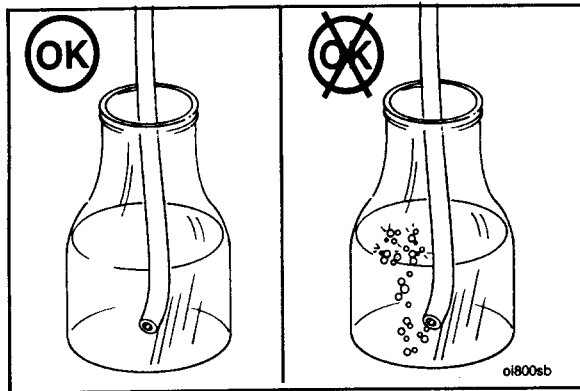

6. Check for a continuous flow of air bubbles from the hose in the container of water.
7. A continuous flow of air bubbles indicates that the check valve is defective and **must** be replaced.

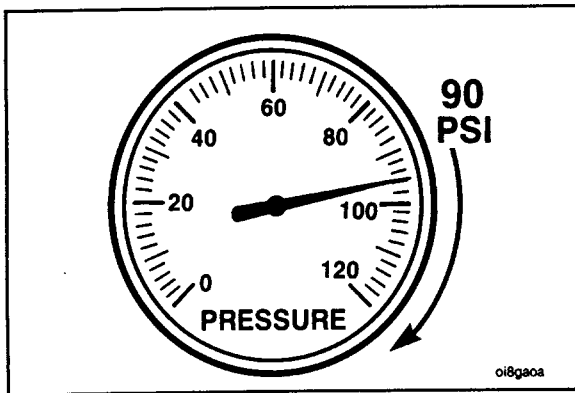

Operational Check

1. The vehicle air system **must** provide more than 620 kPa [90 psi] air pressure from a dry air supply to operate the MVT system.

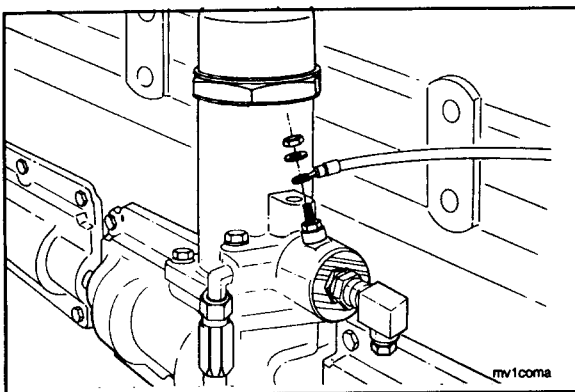

2. Remove the electrical wire from the MVT air solenoid.

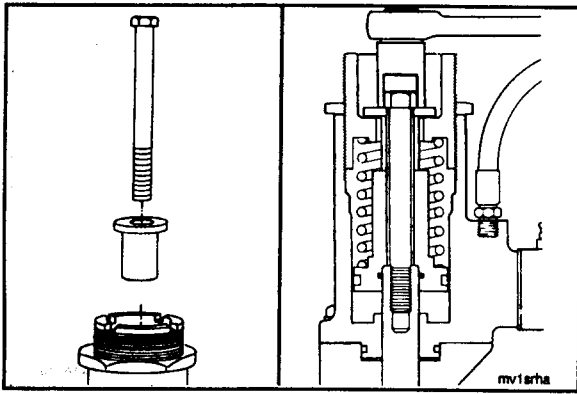

7. Install the timing spacer and the capscrew through the spring retainer. Tighten the capscrew to 60 N•m [45 ft-lbs] torque.

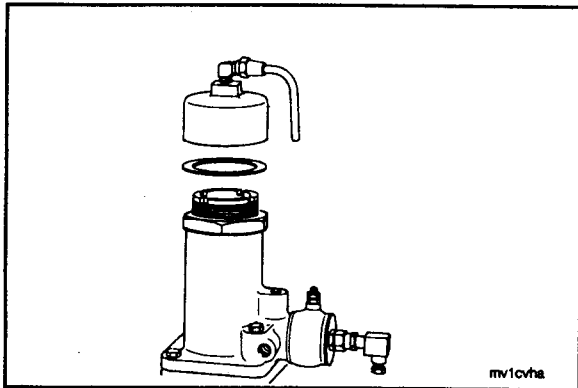

8. Install the washer (if equipped) and the actuator cap. Tighten to 40 N•m [35 ft-lbs] torque.

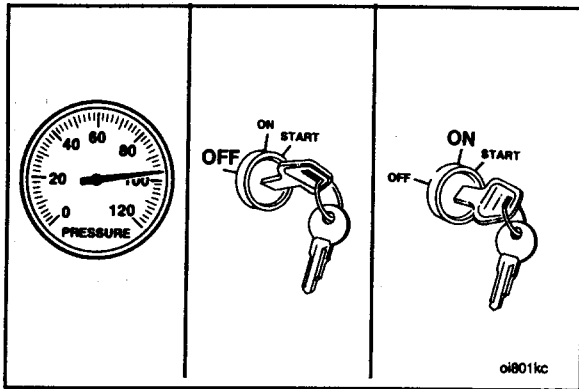

9. Operate the engine until the vehicle air pressure exceeds 620 kPa [90 psi].
10. Shut the engine off. Turn the ignition key to the "ON" position, but do not start the engine.

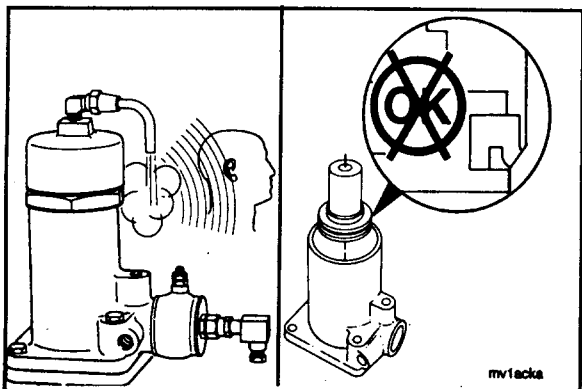

11. Listen for air leakage at the actuator cylinder vent tube.
12. If air leakage is detected at the vent tube, check the actuator plunger seal for damage during installation.

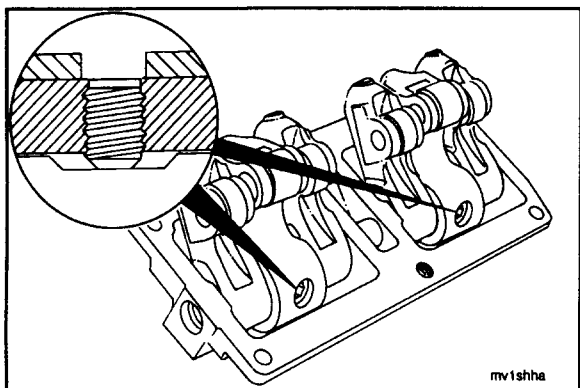

5. Install the shafts in the housings as follows:
 - a. Slide the shaft through the housing and the cam follower lever bores.
 - b. Make sure the flat part of the shaft aligns with the eccentric set screws.

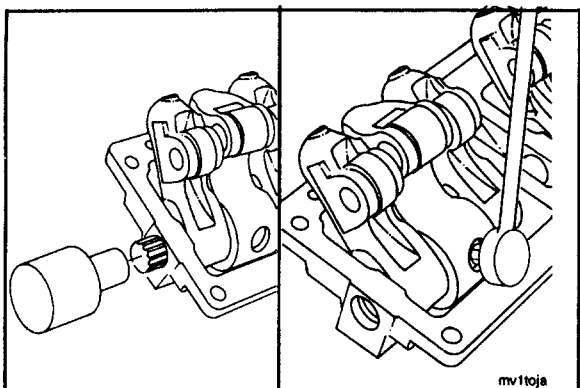

- c. Use Part No. 3376185 Position Gauge to adjust the shaft. The shaft **must** extend from the housing as follows:

Dimensions		
mm		in
23.25	MIN	0.915
23.75	MAX	0.935



- d. Tighten the eccentric set screws to 70 N•m [50 ft-lbs] torque.

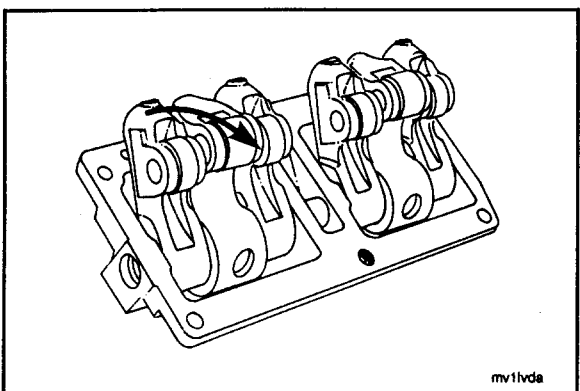

- e. Make sure the cam follower levers move freely on the shaft.

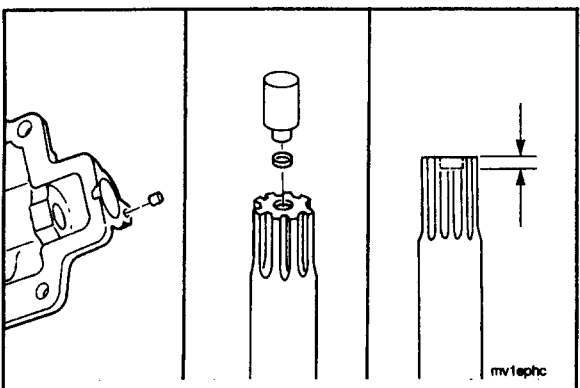

Center Cam Follower Housing

1. Install a roll pin into each end of the cam follower housing.
2. Install an expansion plug into each end of the cam follower shaft as follows:
 - a. Use Part No. 3376186 Expansion Plug Driver.
 - b. Push each plug into the shaft until the plugs are even with the end of the shaft.

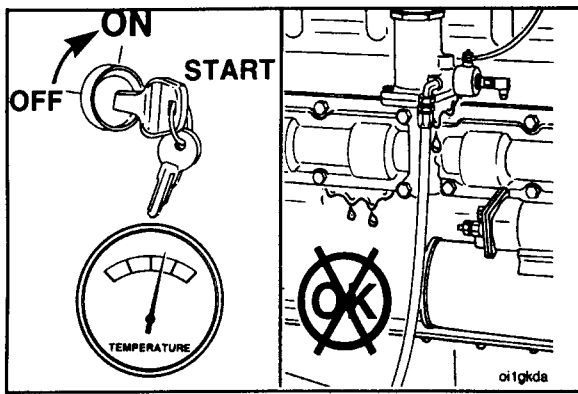

23. Operate the engine until it reaches a temperature of 80°C [180°F], and check for engine operation and lubricating oil or air leaks.

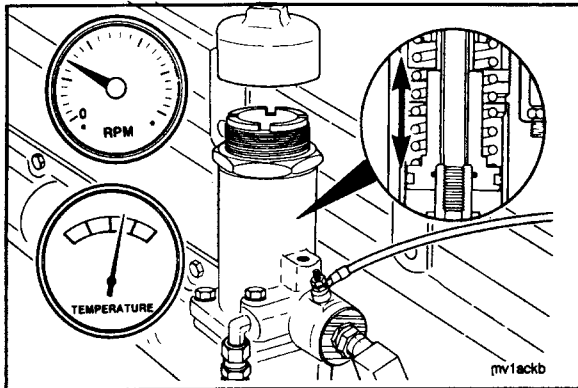

24. Check the actuator for free movement as follows:

- Operate the engine at idle speed.
- Cycle the actuator by connecting and disconnecting the power supply to the solenoid. Refer to Procedure 7-14.
- Cycle the actuator several times to make sure the actuator moves freely.

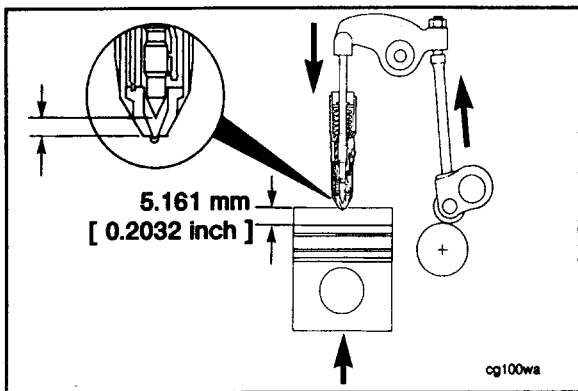

Injection Timing (General Information) - (7-16)

The injection timing is the relative measurement of the distance remaining between the injector plunger and the injector cup when the piston is 5.161 mm [0.2032-inch], or 19 degrees before "TDC" (top dead center) on the compression stroke.

Injector timing is expressed by the amount of push tube travel remaining.

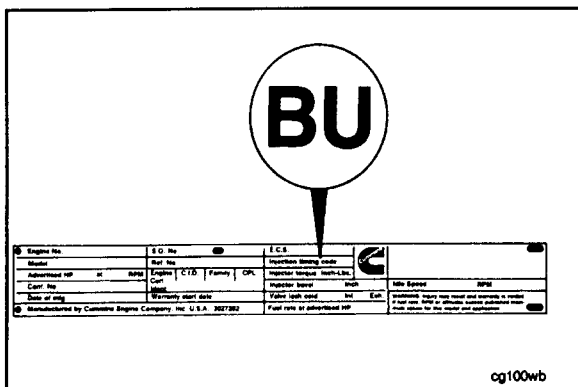

The injection timing code appears on the engine dataplate. Codes are alphabetic letters that relate to a numerical specification.



Specifications can be found in the "Control Parts List (CPL) Manual," Bulletin No. 3379133.

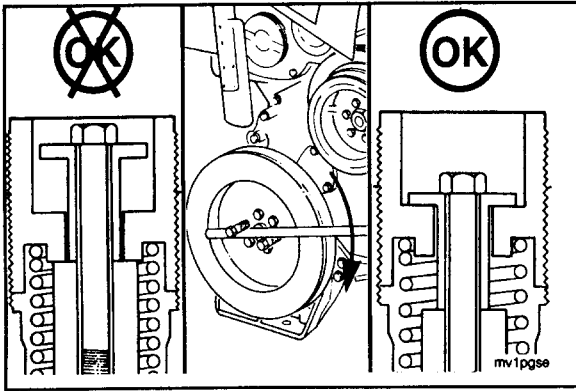

- c. If the plunger is **not** all the way down in the housing, rotate the crankshaft two complete revolutions in the direction of engine rotation (**clockwise**).
- d. Check the position of the actuator plunger.
- e. Lightly tap the spacer capscrew with a plastic hammer to make sure the MVT system is in the fully retarded mode.

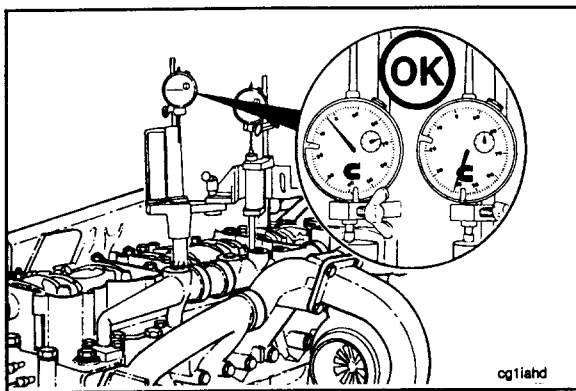

- 2. Install Part No. 3375522 Injection Timing Tool in cylinder No. 3. Refer to Procedure 7-17.

NOTE: Follow steps No. 1 through No. 22 under "Injection Timing (Fixed)" when checking the retarded injection timing. Refer to Procedure 7-17.

Injection Timing Code-CB

Engine No.	S.O. No.	S.C.B.	Injection Timing Code
Model	Ref. No.	Injection Timing Code	Injection Timing Code
Adjustment HP	at RPM	Injection Timing Code	Injection Timing Code
Code No.	Injection Timing Code	Injection Timing Code	Injection Timing Code
Date of entry	Injection Timing Code	Injection Timing Code	Injection Timing Code

Engine Dataplate

cg100sb

- 3. Compare the reading of the injector push rod travel indicator to the specifications listed for the timing code on the engine dataplate.
- 4. If the retarded injection timing is **not** within the specified limits, adjust the timing as follows:

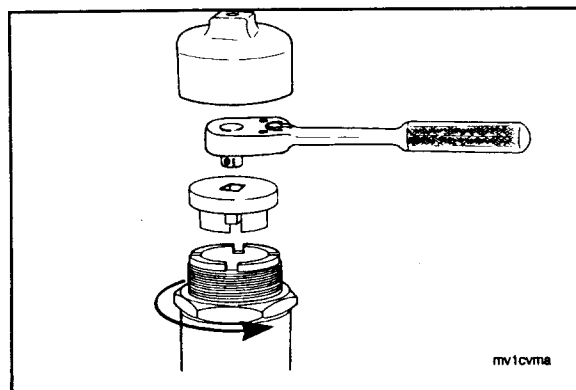

- a. Remove the actuator cap.
- b. Loosen the spring retainer lock nut.

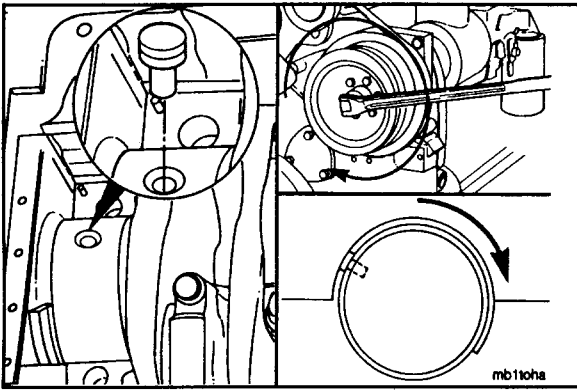

11. To remove the upper main bearing shell, install a tool similar to the one in the picture in the oil hole of the main bearing journal.
12. Rotate the crankshaft with the accessory drive pulley to remove the main bearing shell.

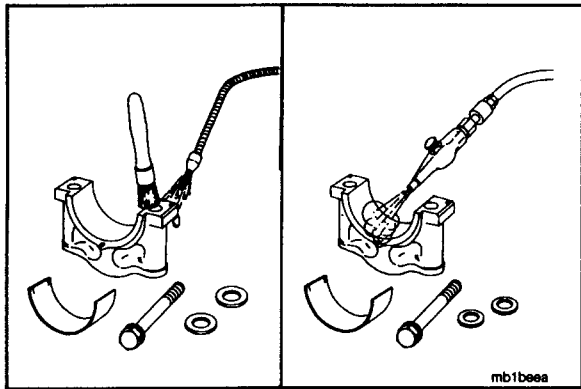

Clean and Inspect

1. Use a soft bristle brush to clean the parts, and dry with compressed air.

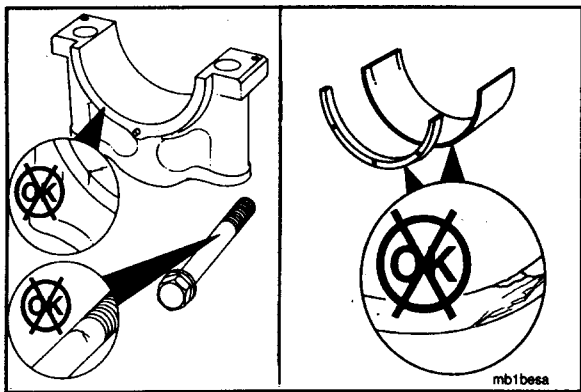

2. Visually inspect the main cap and capscrews for damage.
3. Visually inspect the bearing shells and the thrust bearings for nicks, scratches, or damage.

NOTE: If the main bearings are damaged, refer to the "NT Engine Shop Manual" to inspect the crankshaft main bearing journals. If the crankshaft is damaged, the engine **must** be removed for repair. Refer to Procedure 9-03.

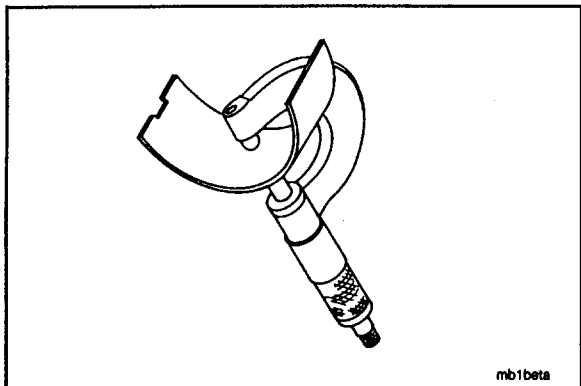

4. Use an outside diameter ball tipped micrometer to measure the main bearing shell thickness.

Standard Main Bearing Shell Thickness		
mm		in
3.086	MIN	0.1215
3.145	MAX	0.1238

5. Discard a main bearing shell if its thickness is below the minimum specification.



NOTE: For more detailed information of bearing damage, refer to "Analysis and Prevention of Bearing Failures," Bulletin No. 3387074.

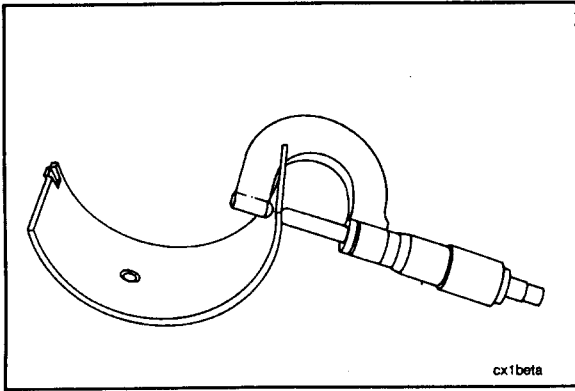

6. Measure the rod bearing shell thickness with an outside micrometer that has a ball tip.

Standard Connecting Rod Bearing Thickness

mm		in
2.362	MIN	0.093
2.405	MAX	0.0947

7. Discard a bearing shell if its thickness is below the minimum specification.

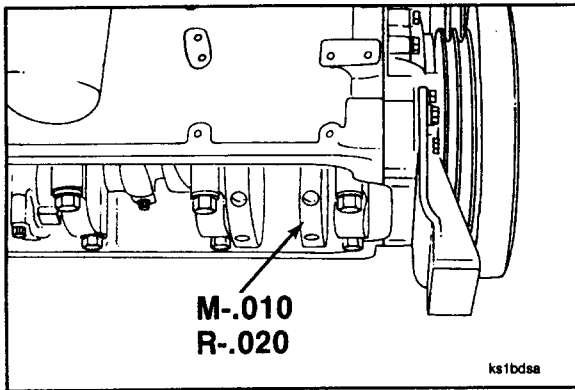

NOTE: Bearing shells are available for crankshafts which are 0.25 mm [0.010-inch], 0.51 mm [0.020-inch], 0.76 mm [0.030-inch], or 1.02 mm [0.040-inch] undersize. Crankshafts which are ground undersize in the connecting rod or the main bearing journals are marked on the front counter weight. If the crankshaft is marked, check the bearing shell part number to make sure the correct bearing size is used.

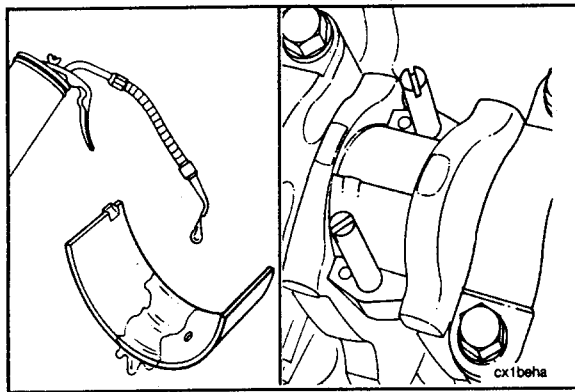

Caution: The connecting rod and bearing shell mating surfaces must be clean and dry when the bearing shells are installed. Used bearings must be installed in their original location.



1. Use clean Lubriplate 105 or its equivalent to lubricate the crankshaft journal mating surface of the upper bearing shell.



2. Install the upper bearing shell in the connecting rod with the tang of the bearing in the slot of the rod.

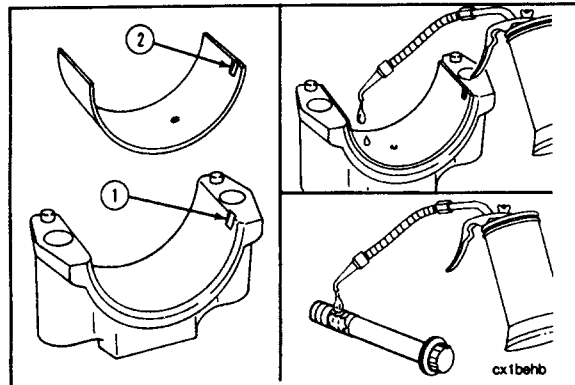

3. Install the bearing shell in the connecting rod cap with the tang (2) of the bearing in the slot (1) of the cap.



4. Use clean Lubriplate 105 or its equivalent to lubricate the bearing shell to crankshaft journal mating surface and the connecting rod capscrews.

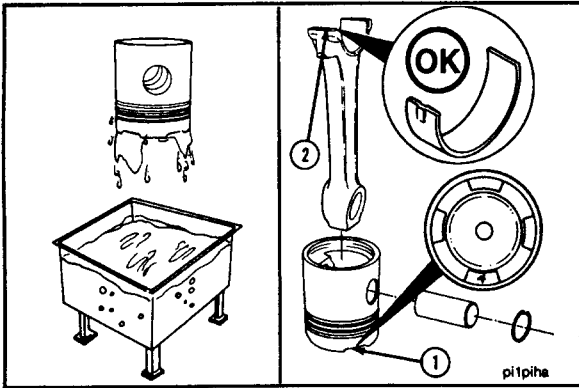

Caution: Use insulated gloves to prevent injury from the boiling water or the heated piston.

4. Remove the piston from the water or the oven.
5. Align the pin bore of the rod with the pin bore of the piston, and install the piston pin. Do not use a hammer to install the piston pin. The piston will be damaged.

NOTE: The cylinder number on the piston top (1) must be toward the bearing tang (2) side of the rod.

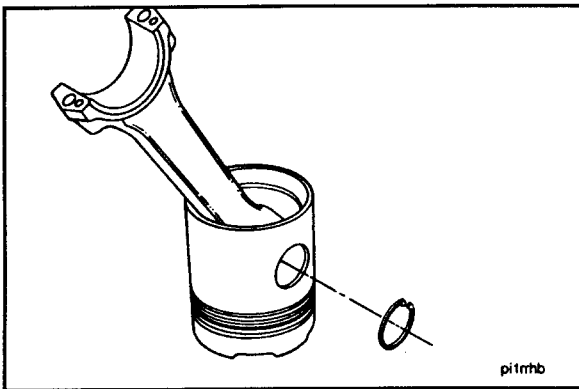

6. Install a new snap ring in the second piston pin bore snap ring groove. The snap ring must be seated completely in the snap ring groove.

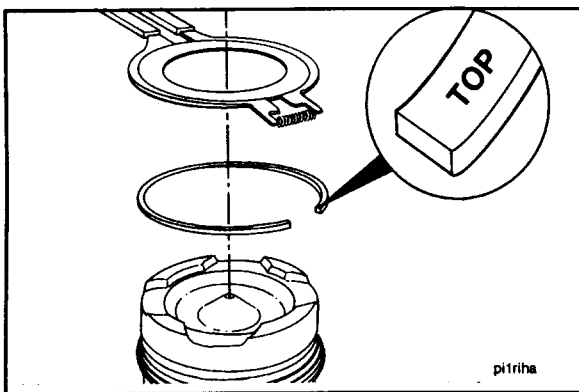

Piston Rings

1. Use Part No. ST-763 Piston Ring Expander to install the piston rings, with the part number, mark, or the word "TOP" toward the top of the piston.

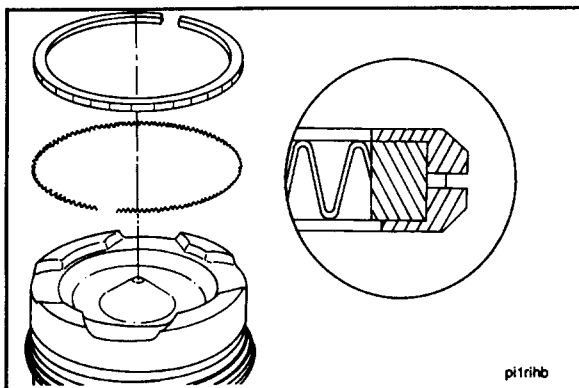

2. A cross-sectioned view of an oil control ring is shown. The two-piece oil control ring must be installed with the expander ring gap 180 degrees from the gap of the oil ring.

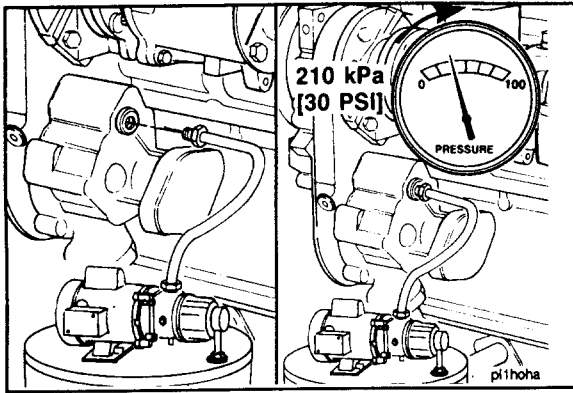

8. Install the priming pump oil supply hose. Use clean 15W-40 lubricating oil out of a bucket or a container. Supply oil to the crossover oil passage.
9. Allow the oil to flow until the oil pressure gauge indicates a maximum pressure of 210 kPa [30 psi] to prime the lubricating oil system.

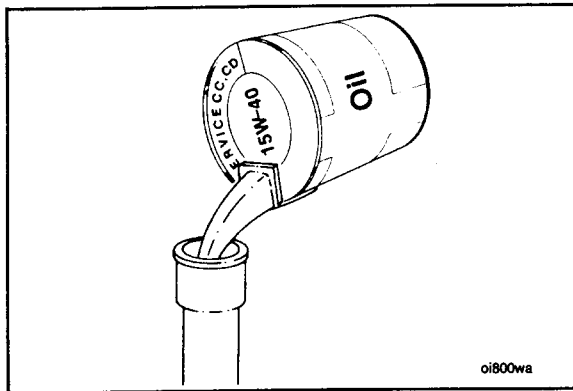

10. Fill the lubricating oil pan. Refer to Procedure 2-10.

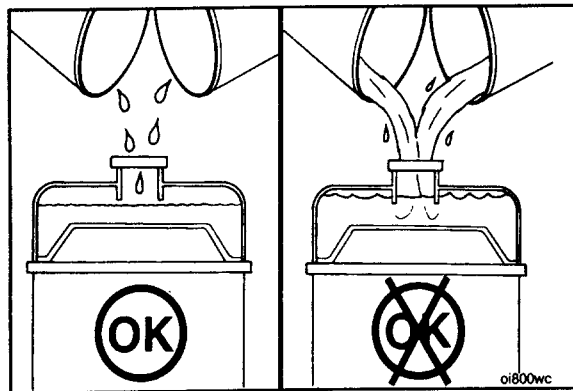

11. Fill the cooling system. Refer to Procedure 1-07.

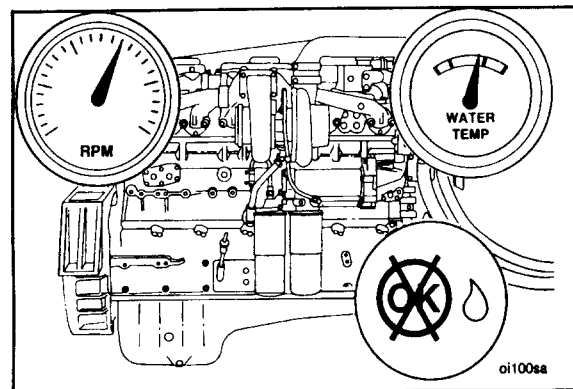

12. Operate the engine until it reaches a water temperature of 80°C [180°F], and check for coolant or lubricating oil leaks.

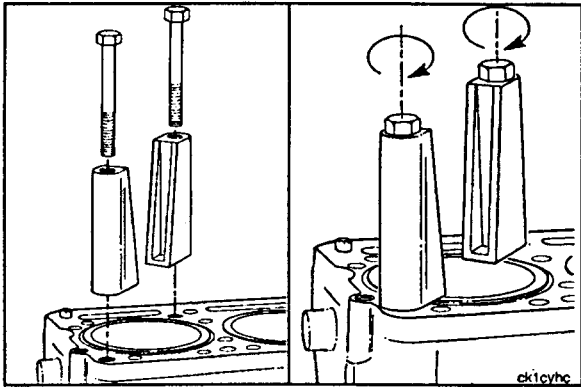

6. Check the protrusion of the cylinder liner as follows:
a. Install Part No. 3376669 Cylinder Liner Clamp Set.

NOTE: The clamp set uses two cylinder head cap screws. The clamps must be installed 180 degrees from each other to apply equal amounts of pressure on the liner.

- b. Tighten the cap screws to 70 N•m [50 ft-lbs] torque. Do not damage the liner bead.

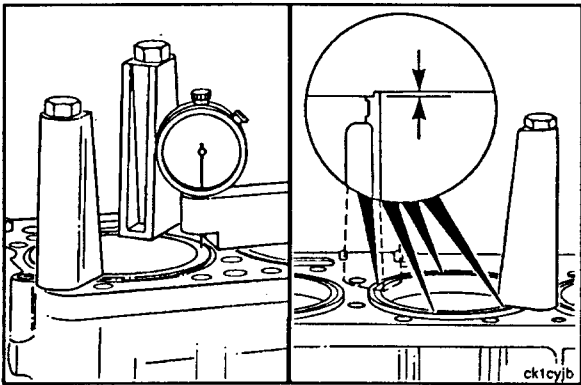

- c. Use Part No. 3376220 Gauge Block to measure the liner protrusion at four points 90 degrees apart. The protrusion must be from 0.08 mm [0.003-inch] to 0.15 mm [0.006-inch].

NOTE: If the liner protrusion is below the specifications, liner shims or oversize cylinder liners may be required. Refer to the "NT Engine Shop Manual" for instructions on repairing the counterbore.

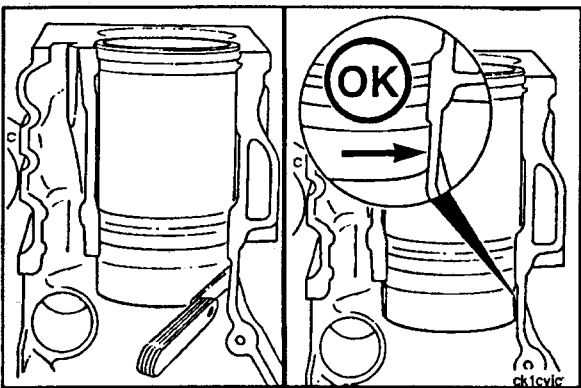

7. Use a feeler gauge to measure the clearance between the liner and the lower liner bore. The clearance must be from 0.05 mm [0.002-inch] to 0.15 mm [0.006-inch].

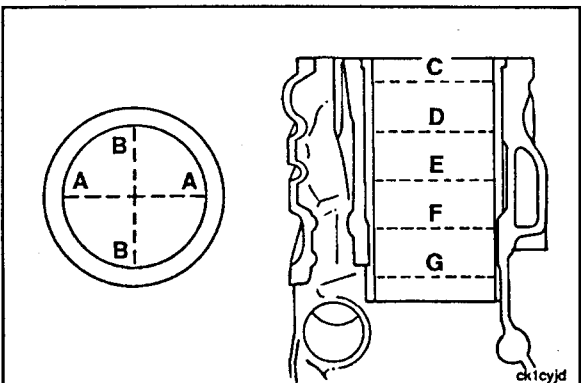

8. Measure the liner bore for out of roundness as follows:

- a. Measure at points "C," "D," "E," "F," and "G."
b. Measure each point in the direction of "AA" and "BB."

- c. At point "C," the liner can not be more than 0.08 mm [0.003-inch] out of round.

- d. At points "D," "E," "F," and "G," the liner bore can not be more than 0.05 mm [0.002-inch] out of round.

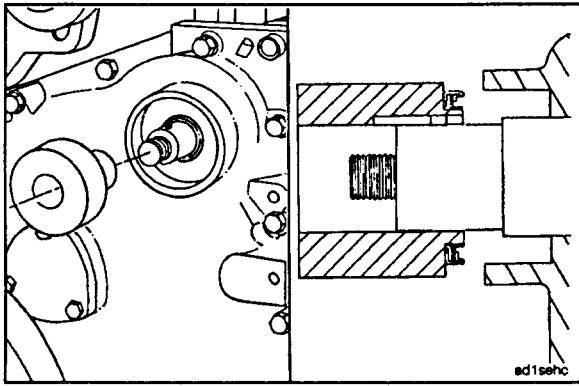

2. Put Part No. ST-1173 Fuel Pump Drive Oil Seal Mandrel over the accessory drive shaft.
3. Align the keyway in the driver with the groove pin in the accessory drive shaft.

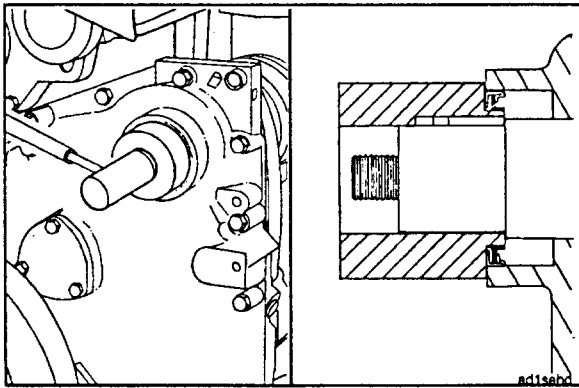

4. Push the seal into the seal bore until the seal casing fits against the ledge.

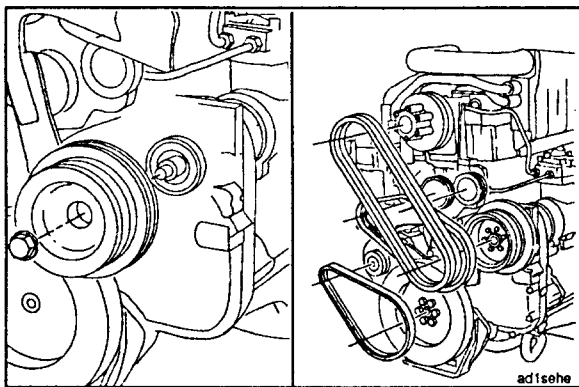

5. Install the accessory drive pulley. Refer to Procedure 7-25.



6. Install the water pump belt, the fan drive belts, and the freon compressor belt (if equipped). Refer to Procedures 1-19 and 1-20, respectively.

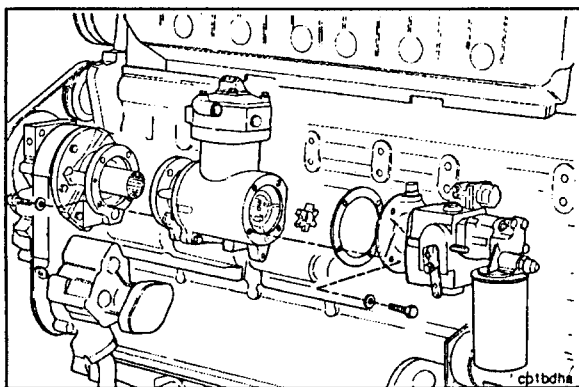

Accessory Drive - Replace (7-28)

Remove

1. Remove the fuel pump. Refer to Procedure 5-07.
2. Remove the air compressor. Refer to Procedure 4-12.



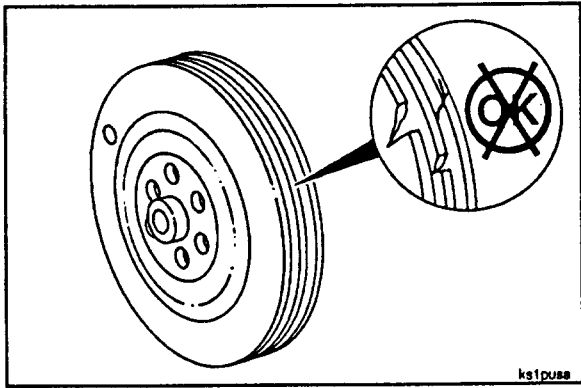

Inspect



1. Visually inspect the pulley for cracks, wear in the belt grooves, or other damage.

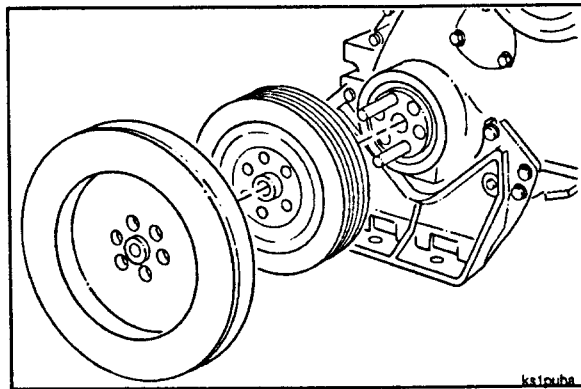

Install



1. Install two guide studs in the crankshaft nose.
2. Install the pulley and the vibration damper on the guide studs.

NOTE: Make sure the mounting surfaces of the crankshaft nose, the vibration damper, and the pulley are clean, dry, and free of burrs.

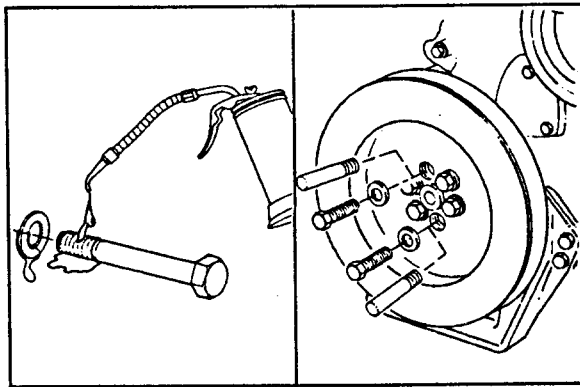

3. Lubricate the mounting capscrew threads and the face of the washers with SAE 30W oil.
4. Install four of the six mounting capscrews. Remove the two guide studs, and install the remaining two capscrews. Tighten the six capscrews to 260 N•m [190 ft-lbs] torque.
5. Check the vibration damper for eccentricity and wobble. Refer to Procedure 7-29.

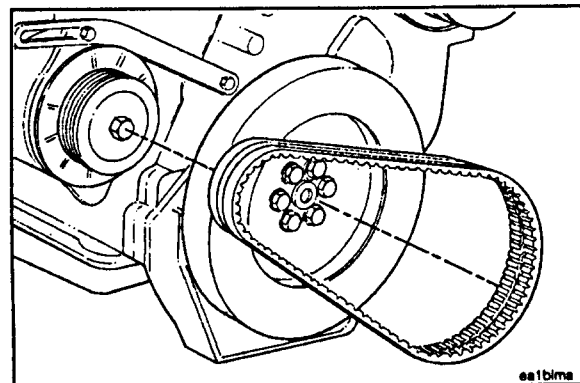

6. Install and adjust the alternator drive belt. Refer to Procedure 6-07.

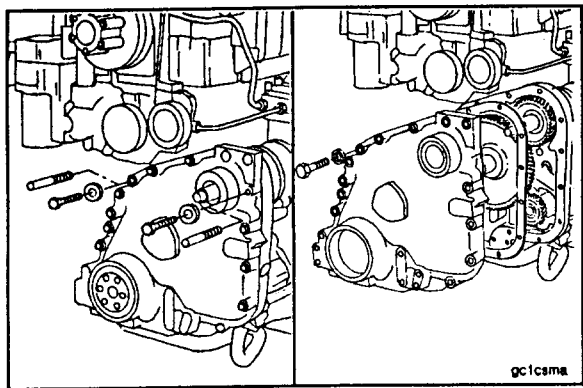

13. Remove one capscrew on each side of the gear cover, and install a 7/16 - 20 x 4-inch guide stud in each location to support the cover during removal.

14. Remove the remaining gear cover capscrews, and remove the gear cover.

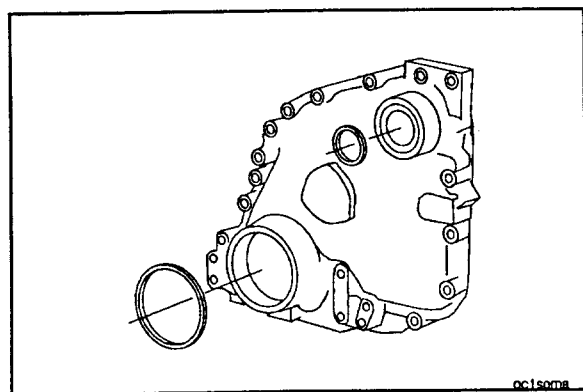

15. Remove the front crankshaft seal and the accessory drive seal.

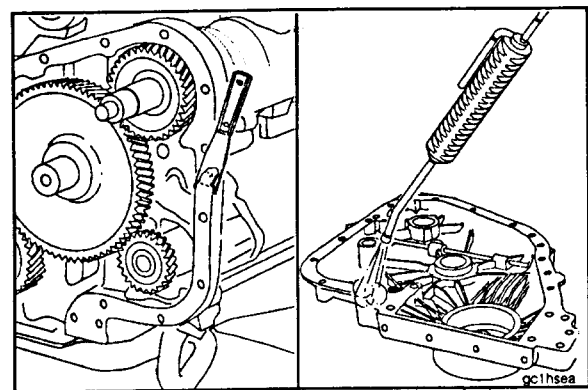

Clean and Inspect

1. Clean the gasket surface of the cylinder block.

2. Clean the gear cover.

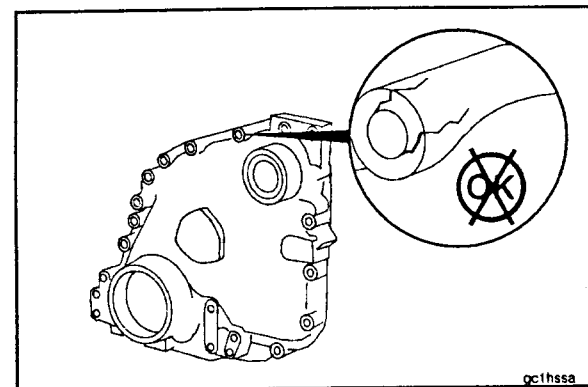

3. Inspect the gear cover for cracks or damage.

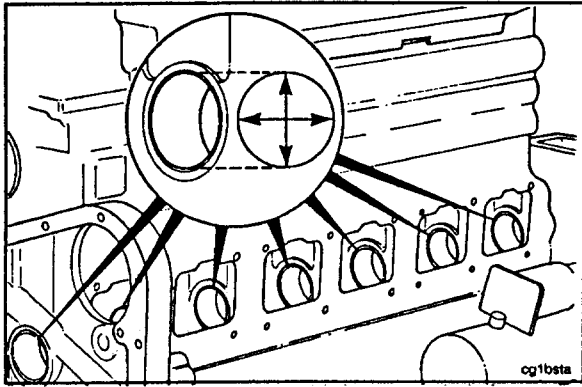

6. Measure the camshaft bushings in the cylinder block. Refer to Procedure 7-38.

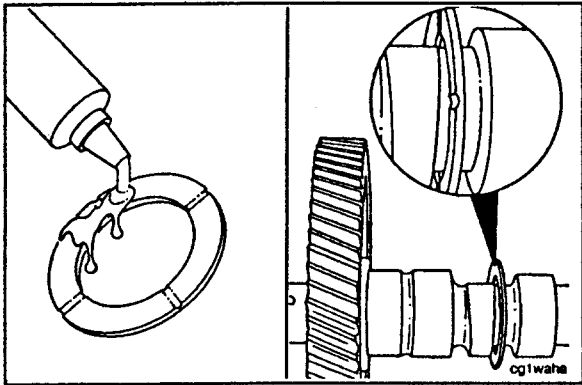

Install

1. Apply a film of Lubriplate 105 or its equivalent to both sides of the camshaft thrust washer.

Caution: The oil grooves on the thrust washer must be toward the camshaft gear to prevent thrust washer failure.



2. Install the thrust washer on the camshaft.

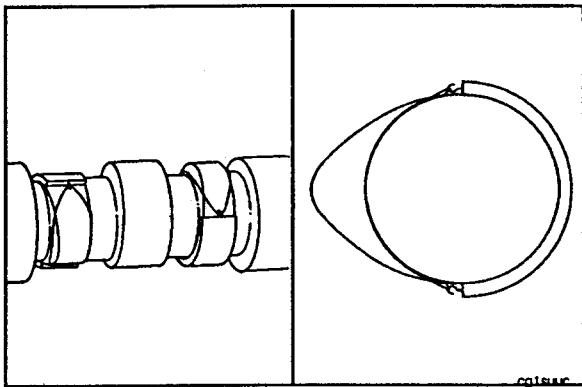

3. Install four camshaft pilots, Part No. 3375268, over the outer base circle of the valve lobes between the camshaft journals.

4. Use a rubber band to hold the installation pilots in place. The rubber band must straddle the valve lobes.

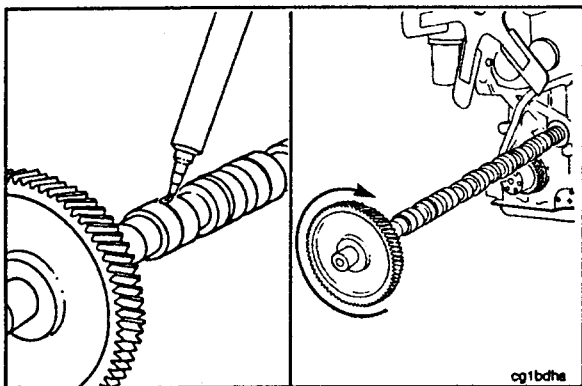

5. Apply a film of Lubriplate 105 or its equivalent to the camshaft journals and the camshaft bushings.

6. Rotate the camshaft slowly as it is being installed in the cylinder block.

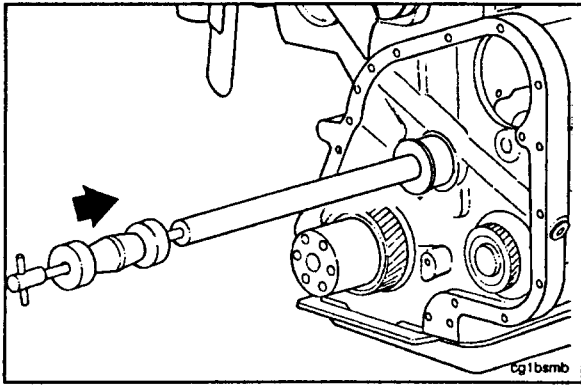

9. To remove bushings No. 1 through No. 6, insert the tool assembly through the camshaft bore until the driver is against the bushing.
10. Hit the slide hammer against the shaft assembly until the bushing is driven from the bore.

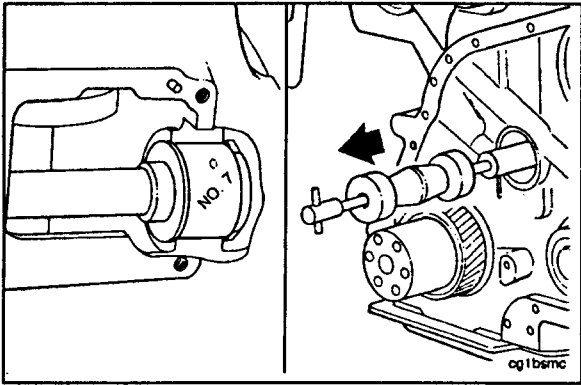

11. To remove the No. 7 bushing, insert the tool assembly through the bore until the pins of the puller assembly are engaged behind the bushing.
12. Hit the slide hammer against the T-handle until the bushing is removed from the bore.

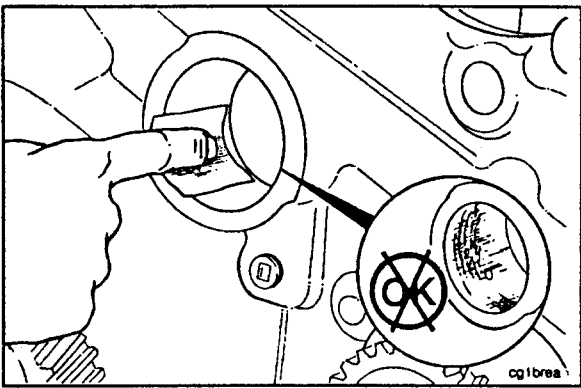

Clean and Inspect

1. Use a fine emery cloth to remove burrs, and clean the bushing bores.

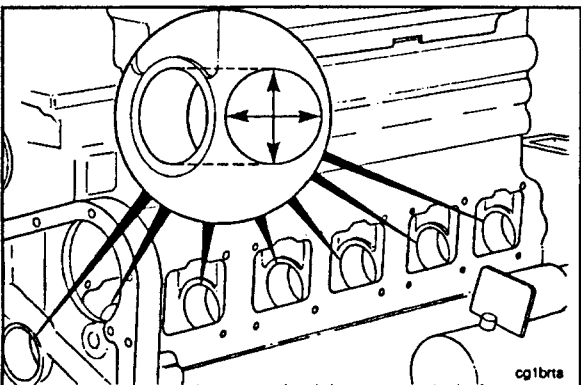

2. Measure the cylinder block camshaft bore inside diameter.

Camshaft Bore I.D.		
mm		in
68.237	MIN	2.6865
68.262	MAX	2.6875

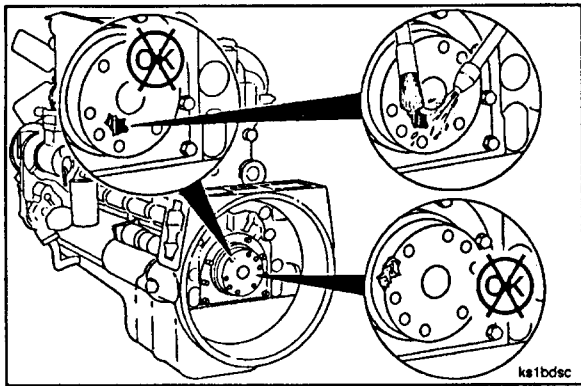

c. Inspect the crankshaft for dirt or damage.

NOTE: Refer to the "NT Engine Shop Manual" to replace the crankshaft.

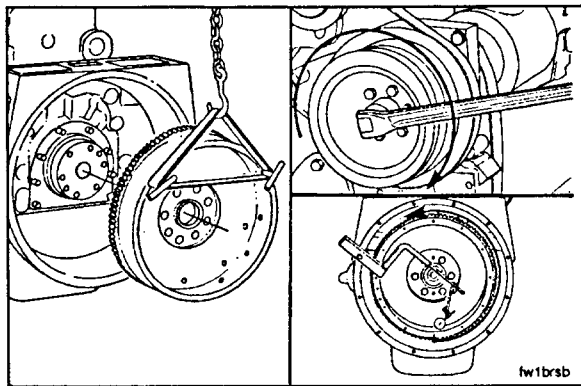

d. Install the flywheel, and inspect the bore runout again.

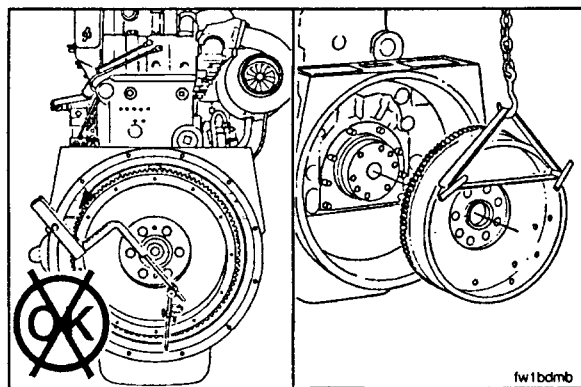

e. Replace the flywheel if the runout does not meet specifications.

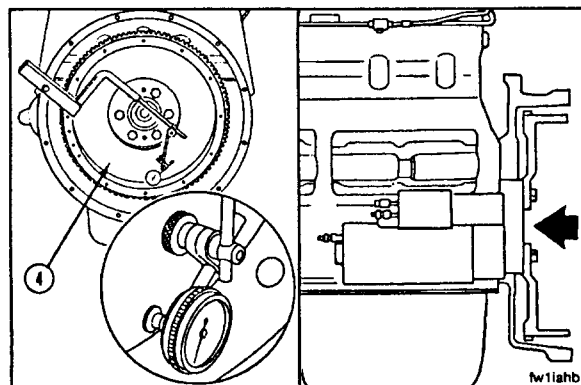

Inspect The Flywheel Face Runout

1. Install the contact tip of the indicator against the flywheel face, as close to the outside diameter as possible, to inspect the face (4) runout.
2. Push the flywheel forward to remove the crankshaft end clearance. Adjust the dial on the indicator until the needle points to "0" (zero).

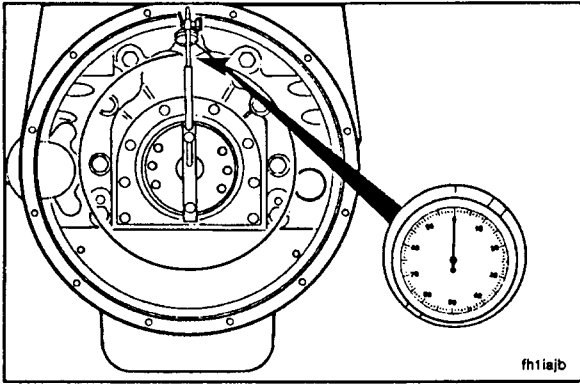

5. Continue rotating the crankshaft until the dial indicator is at the 12:00 o'clock position.
6. Check the dial indicator to make sure the needle still points to "0" (zero).

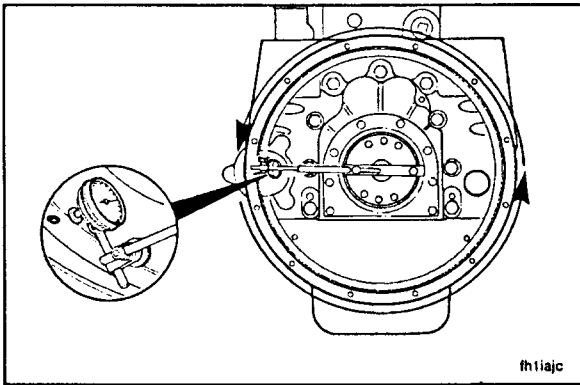

7. Determine the total indicator run out (TIR) as follows:

	mm	in
Example:		
12 o'clock	0.00	0.00
3 o'clock	+ 0.08	+ 0.003
6 o'clock	- 0.05	- 0.002
9 o'clock	+ 0.08	+ 0.003
Equals TIR	0.13	0.005

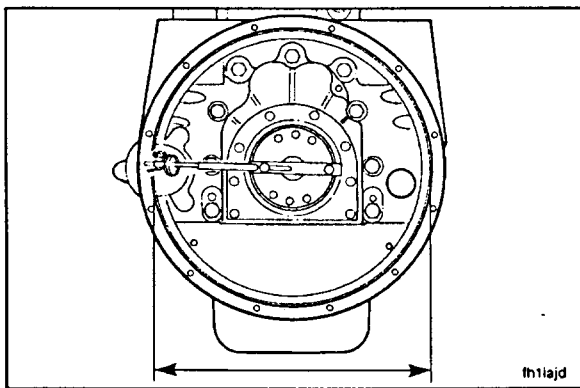

8. The maximum allowable total indicator reading (TIR) depends on the diameter of the housing bore. See the following chart:

SAE No.	Bore Diameter		Bore Location Tolerance	
	mm	in	mm	in
00	787.40 to 787.65	31.000 to 31.010	0.30	0.012 TIR
0	647.70 to 647.95	25.500 to 25.510	0.25	0.010 TIR
1/2	584.00 to 584.20	23.000 to 23.008	0.25	0.010 TIR
1	534.27 to 534.40	20.125 to 20.130	0.20	0.008 TIR
2	447.68 to 447.80	17.625 to 17.630	0.20	0.008 TIR
3	409.58 to 409.70	16.125 to 16.130	0.20	0.008 TIR

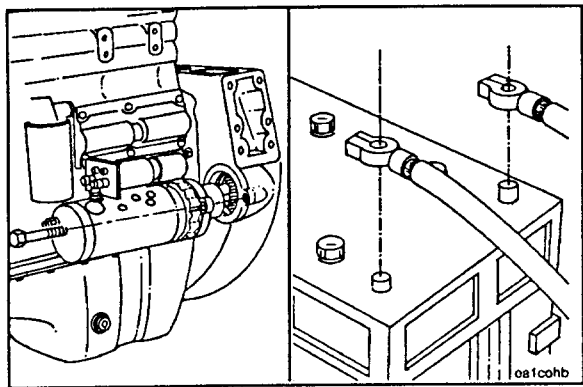

35. Install the starting motor. Refer to Procedure 6-10.
36. Connect the battery cables.

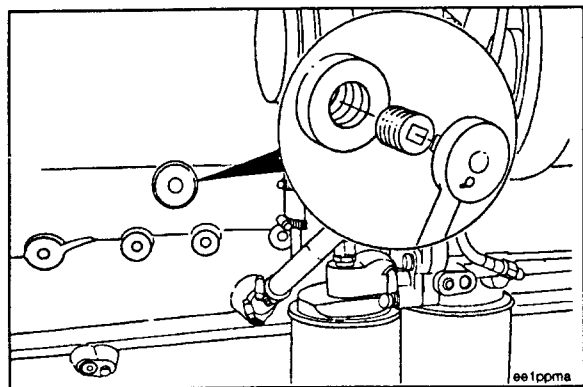

Pipe Plugs and Cup Plugs - Replace (7-43)

Pipe Plugs - Remove

1. Select the appropriate size wrench, and remove the pipe plug.

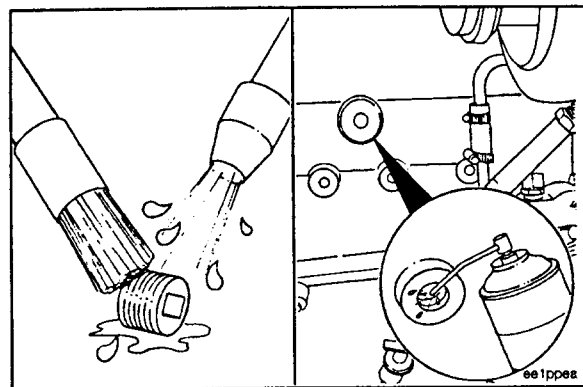

Clean and Inspect

1. Use solvent to clean the threads of the pipe plugs and the threaded bores.

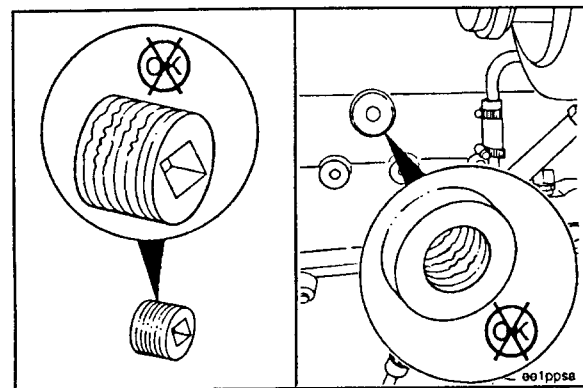

2. Visually inspect the threads of the pipe plugs for mutilation or damage.
3. Visually inspect the threaded bores for damage.
4. Repair the bores if necessary.

Caution: Do not allow the engine speed to exceed 1,000 RPM before run-in. The internal components can be damaged.

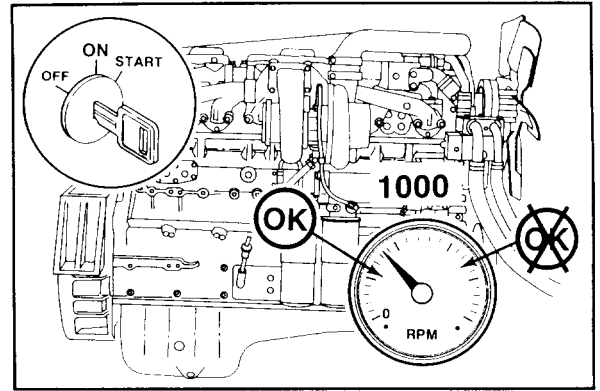

Caution: Do not shut the engine off immediately after the last step of the run-in is completed. Allow the engine to cool by operating at low idle for a minimum of 3 minutes to avoid internal component damage.

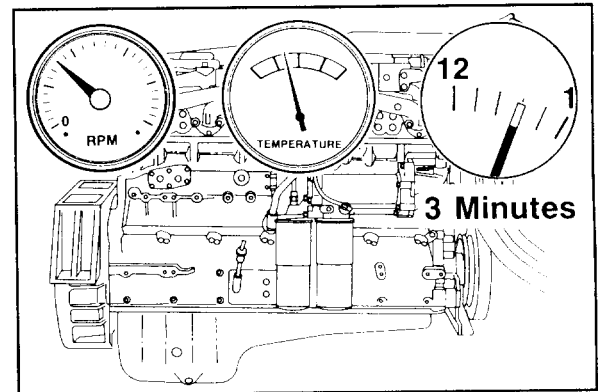

Chassis Dynamometer Operation - (8-02)

1. The performance of an engine installed in "on-highway" vehicles can be tested on a chassis dynamometer.

NOTE: Due to driveline efficiency and engine-driven accessories, the wheel horsepower (WHP) will be reduced by approximately:

- 20 percent for single axle vehicles
- 25 percent for tandem axle vehicles

NOTE: These percentages are used for engines run-in only and are **not** to be used as absolute figures.

Caution: Follow all the vehicle manufacturer's safety precautions before installing or operating a vehicle on a chassis dynamometer.

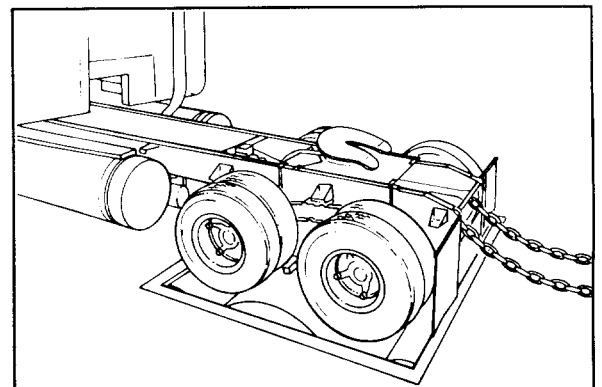
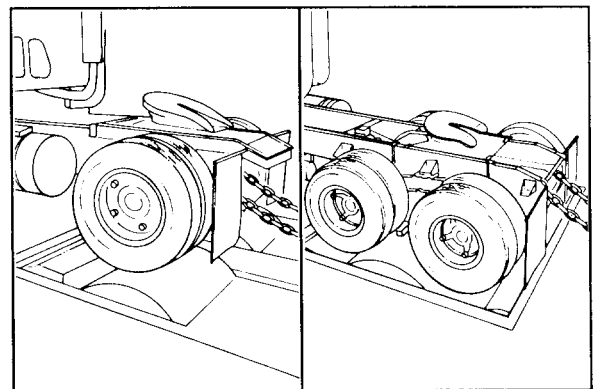

13. Remove and use all remaining accessories and brackets with the replacement engine.

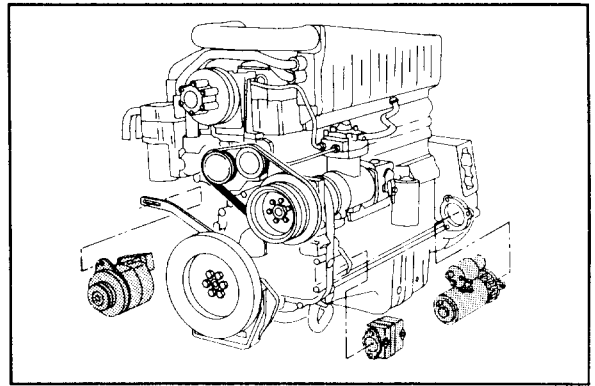

Engine Mounts - Inspect (9-04)

1. Inspect all rubber-cushioned mounts for cracks or damage.
2. Inspect all mounting brackets for cracks or damaged bolt holes.

NOTE: Damaged engine mounts and brackets can cause the engine to move out-of-alignment, can damage the driveline components in the equipment, and can result in vibration complaints.

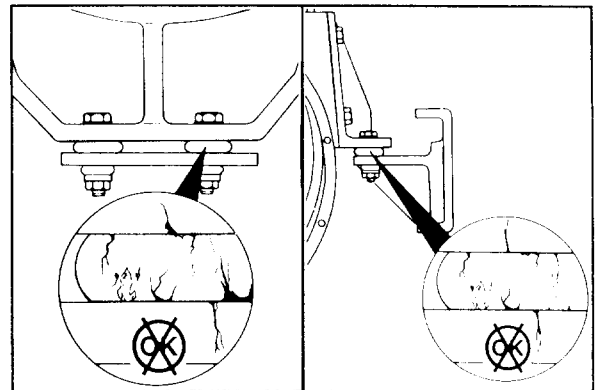

Engine - Install (9-05)

1. Install all accessories and brackets that were removed from the previous engine.

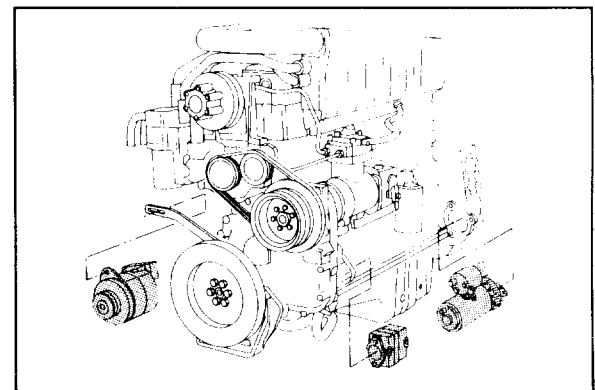

NOTE: If the rear engine mounts are attached to the transmission, it may be necessary to install the engine and the transmission as an assembly.

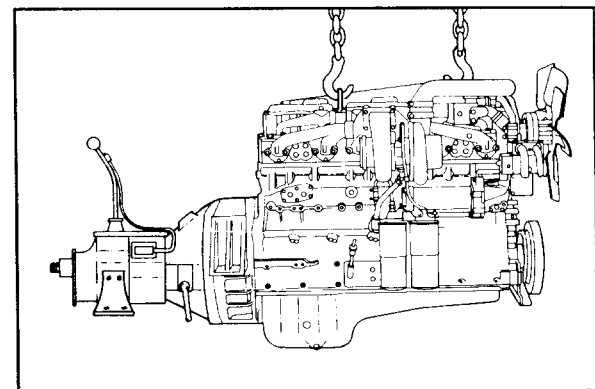

Fan Hub (Refer to Procedure 1-26)

		End Clearance	
mm		in	
0.08		MIN	0.003
0.25		MAX	0.010

Thermostat - Operating Temperature Range - Traditional Aftercooled Engines (Big Cam III) (Refer to Procedure 1-31)

°C	Nominal Setting	Fully Open		Start to Open		°F	°C	°F	°C	°F
		°C	Min	°F	°C					
71	160	70		158	72	162	83	182		
77	170	76		168	78	172	89	192		
79	175	78		173	80	177	92	197		
82	180	81		178	83	182	94	202		
85	185	84		183	86	187	97	207		

Full Open Space between Seal Sleeve and Cross Section
9.50 mm [0.375-in]

Radiator Thermostat - Operating Temperature Range - Optimized Aftercooled Engines (Big Cam IV) (Refer to Procedure 1-33)

Normal Position	Start to Open						Fully Open					
	°C	Min	°F	°C	Max	°F	°C	Min	°F	°C	Max	°F
Closed	77		171	80		175	89		193	92		197

NOTE: The thermostat operating temperature **must** be checked with the thermostat installed in the engine. Refer to Procedure 1-33.

Bypass Thermostat - Operating Temperature Range - Optimized Aftercooled Engines (Big Cam IV) (Refer to Procedure 1-34)

Normal Position	Fully Closed Temperature					
	°C	Min	°F	°C	Max	°F
Open	84		183	86		187

NOTE: The thermostat operating temperature **must** be checked with the thermostat installed in the engine. Refer to Procedure 1-34.

Base Engine Components Torque Values - (10-12)

Component	Procedure No.	Torque N•m [ft-lbs]
Accessory Drive Mounting Capscrews	7-28	60 [45]
Accessory Drive Pulley Retaining Nut	7-25	420 [310]
Air Crossover Connection Capscrews (Big Cam III)	7-03	35 [25]
Cam Follower Assembly Mounting Capscrews	7-13 and 7-15	45 [35]
Camshaft Support Thrust Bearing	7-32	25 [20]
Connecting Rod Capscrews	7-21 and 7-22	Step a. 100 [75] Step b. 230 [170]
Crosshead Adjusting Screw Lock Nut	7-04	40 [30]
With Part No. ST-669 Adapter		35 [25]
Jacobs® Brake Model 401 Crosshead Adjusting Screw		35 [25]
Without ST-669 Adapter		30 [22]
With ST-669 Adapter		30 [22]
Cylinder Head Mounting Capscrews	7-11	Step a. 35 [25] Step b. 135 [100] Step c. 385 [285]
Engine Lifting Bracket Capscrews	7-04	80 [60]
Flywheel Housing Mounting Capscrews	7-41	205 [150]
Flywheel Mounting Capscrews	7-39	270 [200]
Front Engine Support Bracket Mounting Capscrews	7-33	70 [50]
Gear Cover Mounting Capscrews	7-34	70 [50]
Hose Clamps:		
T-Bolt Type	--	8 [70 in-lbs]
Worn Screw Type	--	5 [40 in-lbs]
Injector Adjusting Screw Lock Nut	7-04	60 [45]
With Part No. ST-669 Adapter		35 [45]
Injector Hold Down Clamps	7-04	18 [156 in-lbs]
Jacobs® Brake Assembly Hold Down Nuts	7-07	80 [60]
Jacobs® Brake Slave Piston Adjusting Screw Lock Nut	7-05	35 [25]
With Part No. ST-669 Adapter		30 [22]
Main Bearing Cap Capscrews (3/4-inch Diameter)	7-20	Step a. 120 [90] Step b. 230 [170] Step c. 345 [255] Step d. Loosen completely Step e. Repeat a. thru c.
Main Bearing Cap Capscrews (1-inch Diameter)	7-20	Step a. 150 [110] Step b. 285 [210] Step c. 415 [305] Step d. Loosen completely Step e. Repeat a. through c.
Mechanical Variable Timing (MVT) Actuator Cap	7-15 and 7-18	40 [30]
MVT Actuator Housing Mounting Capscrews	7-15	25 [20]
MVT Actuator Shaft Retaining Capscrew	7-14 and 7-15	60 [45]
MVT Air Filter	7-15	3 [25 in-lbs]
MVT Air Filter Elbow	7-15	3 [25 in-lbs]
MVT Air Solenoid Valve Jam Nut	7-15	5 [45 in-lbs]
MVT Eccentric Set Screw	7-15	70 [50]
Component	Procedure No.	Torque N•m [ft-lbs]
MVT Spring Retainer Lock Nut	7-14	45 [35]
Oil Pan Mounting Capscrews:		
5/16-inch Capscrews	7-34	25 [20]
7/16-inch Capscrews	7-34	70 [50]
Pipe Plug Torque Values	7-43	Refer to Chart
Piston Cooling Nozzle Mounting Capscrews:		
Hexagon Capscrews	7-19	15 [140 in-lbs]
Slotted Head Screws	7-19	10 [95 in-lbs]

	Section No.	Reference/ Procedure No.
Engine		
- Cleaning Instructions	I	Page 10
- Component Specifications.....	10	10-06 - 10-12
- Diagrams	E	Page 5
- Driveability (Low Power) - Check List	5	Page 83
- Identification (Dataplate).....	E	Page 2
- Internal Damage - Check	2	2-05
- Install.....	9	9-05
- Lifting Brackets.....	7	7-03
- Mounts - Inspect	9	9-04
- Repair Instructions.....	I	Page 9
- Remove	9	9-03
- Run-in Procedure		
Chassis Dynamometer.....	8	8-03
In-Chassis	8	8-04
- Support Bracket (Front) - Replace.....	7	7-33
Exhaust Restriction - Check	3	3-09
Exhaust Manifold - Replace	3	3-15
Fan		
- Pulley - Inspect	1	1-18
- Shroud - Inspect	1	1-18
- Spacer - Inspect.....	1	1-18
Fan Clutch		
- Air Engaged Type	1	1-22
- Air Disengaged Type.....	1	1-23
- On-Off Type - Check	1	1-21
- On-Off Type - Replace	1	1-24
Fan Clutch, Viscous Type	1	1-25
Fan Drive Belts - Replace.....	1	1-20
Fan Hub - Replace.....	1	1-26
Flow Diagrams		
- Combustion Air	3	3-03
- Compressed Air	4	4-03
- Cooling System.....	1	1-03
- Fuel System.....	5	5-03
- Lubricating Oil System.....	2	2-04
Flywheel - Replace	7	7-39

CLICK HERE TO **DOWNLOAD** THE COMPLETE MANUAL

- Thank you very much for reading the preview of the manual.
- You can download the complete manual from: www.heydownloads.com by clicking the link below



- Please note: If there is no response to CLICKING the link, please download this PDF first and then click on it.

CLICK HERE TO **DOWNLOAD** THE COMPLETE MANUAL