

**REPAIR
MANUAL**

CLAAS

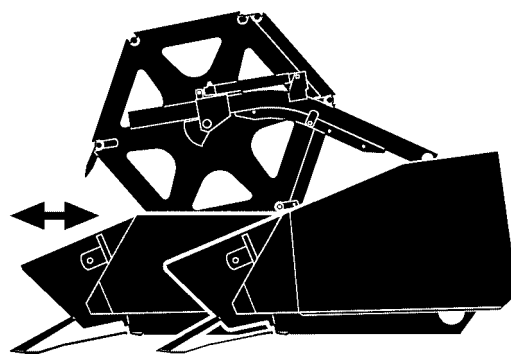

CLAAS

CUTTERBAR

VARIO 5.40 m - 7.50 m

CLICK HERE TO **DOWNLOAD** THE COMPLETE MANUAL

- Thank you very much for reading the preview of the manual.
- You can download the complete manual from: www.heydownloads.com by clicking the link below







- Please note: If there is no response to CLICKING the link, please download this PDF first and then click on it.

CLICK HERE TO **DOWNLOAD** THE COMPLETE MANUAL

Key to symbols

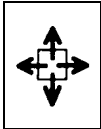
This CLAAS REPAIR MANUAL uses some symbols as defined in the "DIN 30600 Symbol summary" by the German Standardisation Institute (DIN).

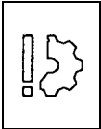
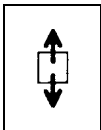
The meaning of these symbols will be easily recognised and remembered by the user. These symbols are to help to quickly recognise recurring service procedures and they also help to communicate information shown on the illustrations.

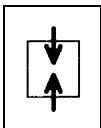
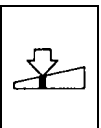
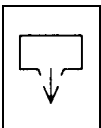
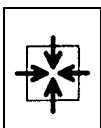
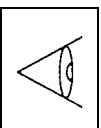
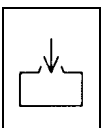
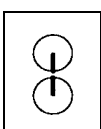
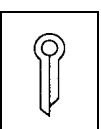
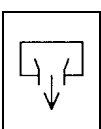
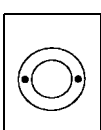
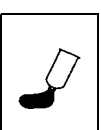
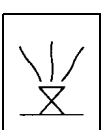
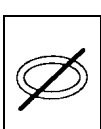
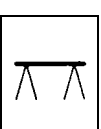
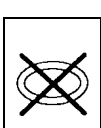
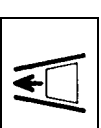
	Dismantle, remove		Grease		Prevent damage to materials
	Disassemble		Oil		Special tools
	Assemble		Adjust/set		Drain, outlet
	Install, mount on		Check visually		Fill, filler opening
	Mark		Unlock, release, secure		Overflow
	Balance		Lock by means of liquids, glue, seal		Bleed
	Possibly reuseable		Underprop, support		
	Renew on each assembly		Observe direction of installation		

3

***Cutterbar trough –
Cutter bar***

CUTTERBAR LOCK

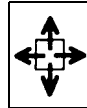
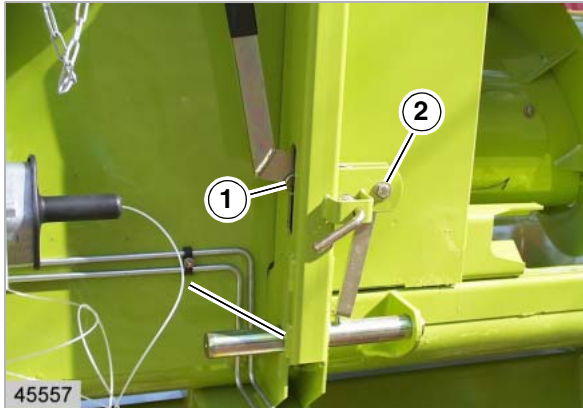

Removing the cutterbar lock

Pull out spring clip (1).

Unscrew hexagon bolt (2).

(Fig. 1)

1

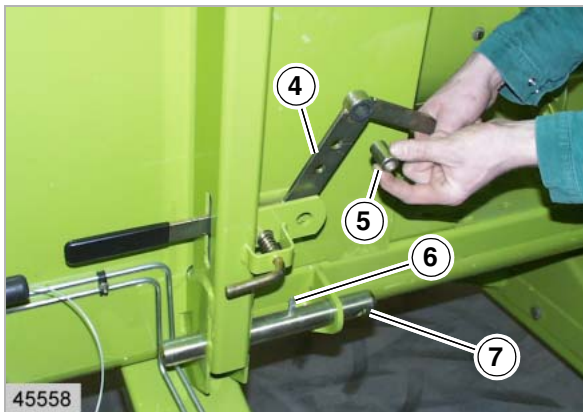

Unhook rod (3) at the bottom and remove lever (4) with bushing (5).

If required, drive out expansion pin (6) and remove pin (7).

(Fig. 2, 3)

2

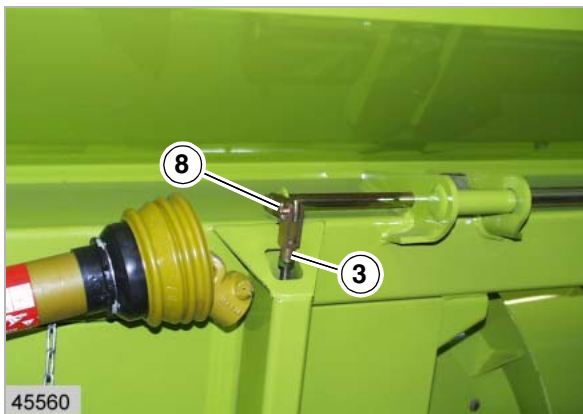

Release pin (8) and pull out rod (3) to the top.

(Fig. 3)

3

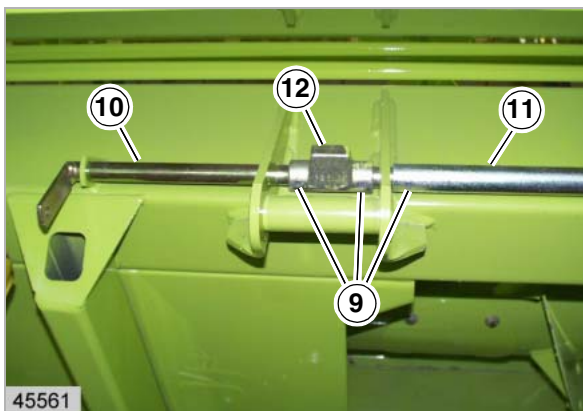

Drive out expansion pins (9). Pull adjusting shaft (10) out of the tube (11) and remove pawl (12).

(Fig. 4)

4

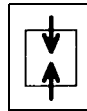
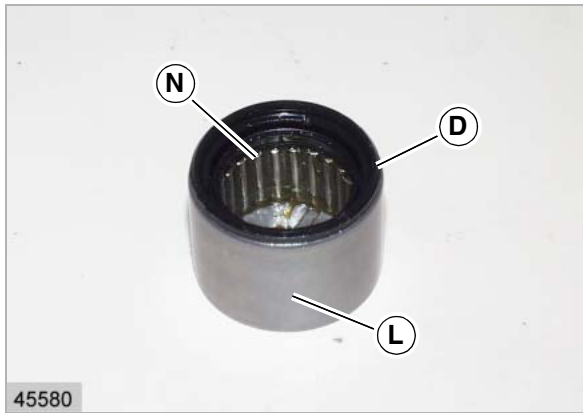

Assembling the main drive universal drive shaft
 Pull off bearing sleeves (L) from the new centre cross assembly.



Caution!

The bearing sleeves must always be fully covered with needles (N).
 Grease needles (N) if required.
 The seals (D) must be properly inserted in the bearing sleeves..

13

(Fig. 13)



14

For easier servicing of the universal drive shafts, grease nipple (9) should be pre-assembled at a 45° angle with the studs of the centre cross assembly (8).

(Fig. 12, 14)

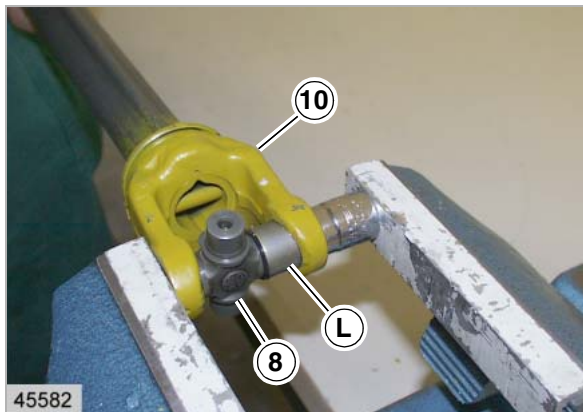

15

Install centre cross assembly (8) in the yoke (10).

When forcing in the bearing sleeves (L), guide the bearing needles (N) with the studs.



Caution!

The bearing needles (N) must not fall out or be damaged.

Force in the bearing sleeves until the annular groove is visible.

(Fig. 13, 15)

KNIFE DRIVE

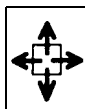
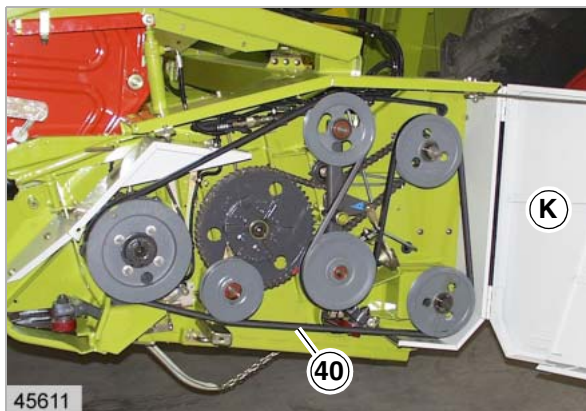

Removing the knife drive belt (40)

Open door (K).
Relieve the tension of knife drive belt (40).
(Fig. 1)

1

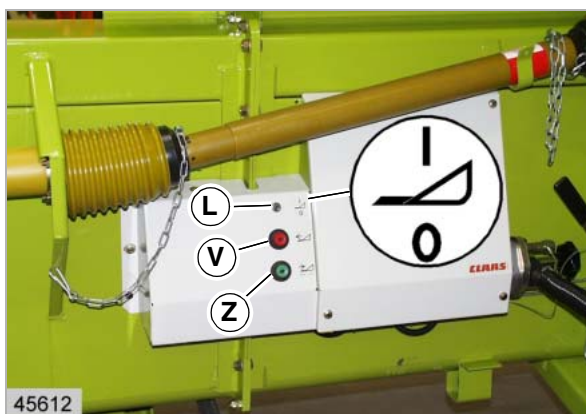

Relieve the tension of knife drive belt as follows:

- Switch on rocker switch (L). To do this, set the lever to position (1).
- Now move VARIO table forward by actuating the pushbutton (V).
- Now insert spring clip (1) into the left-hand hole (L) on the pull cylinder.
- Now move the VARIO table fully to the rear by actuating the pushbutton (Z).

2



Danger!

Now stop engine and remove ignition key.

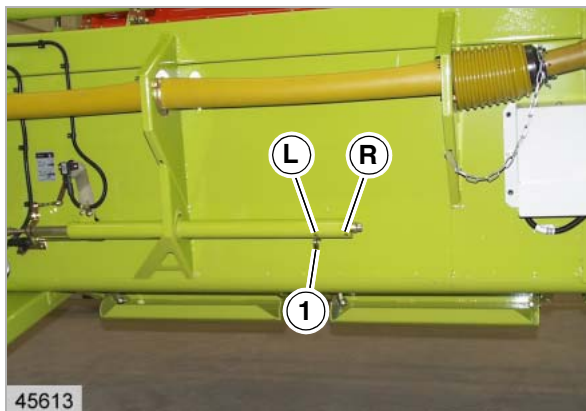

3

(Fig. 2, 3)

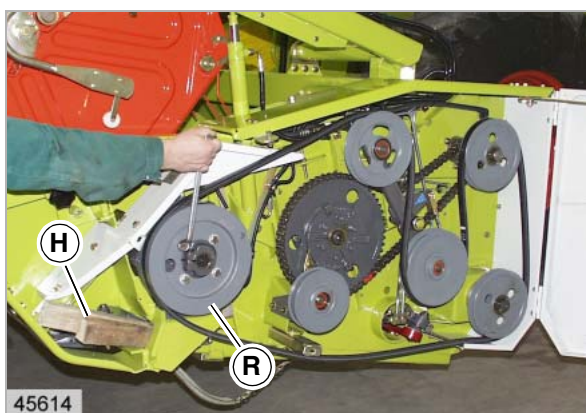

4

Remove knife drive pulley (**only on 7.5 m cutterbars**).

Block swinging yoke of wobble transmission with a wooden wedge (H).

Unscrew the knife drive pulley (R).

(Fig. 4)

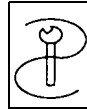

Release slotted nut (6) and unscrew with special tool.
(Fig. 35, 36, 43, 44)

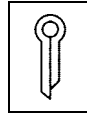

35

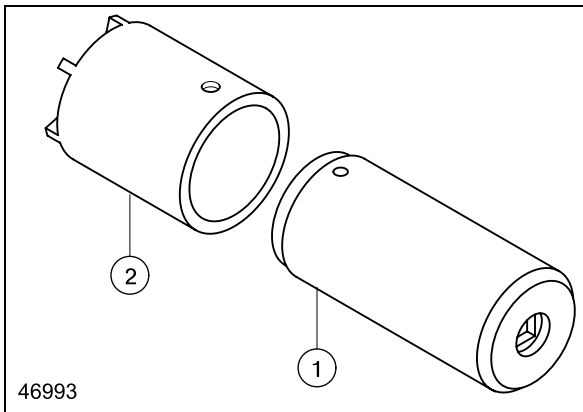

Special tool:

1. Base tube
Spare part no. 181 641.0
or
Spare part no. 181 964.0
2. Special socket spanner
Spare part no. 181 615.0

(Fig. 35, 36)

36

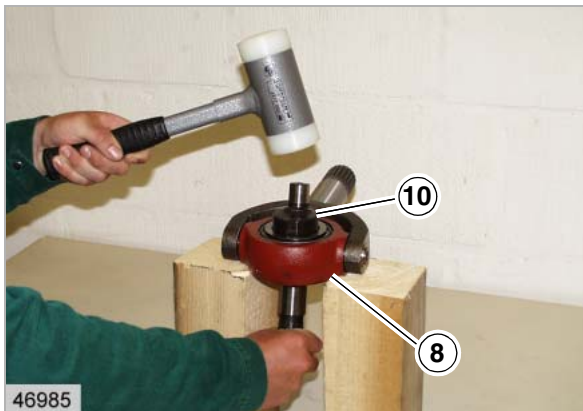

Drive wobble shaft (10) and taper roller bearing (7) out of the wobble housing (8).



Important!

The bearing ring must not have contact at the edge of the support bearing.

(Fig. 37, 43, 44)

37



Drive wobble shaft (10) through with plastic-tip hammer.

(Fig. 38)

38



64

Insert wobble shaft with swinging yoke into the transmission housing.

Apply a little oil to the O-ring (16) and install it.

Place bearing housing (17) in position.

(Fig. 64)



65

Place bearing housing (17) in position.

Drive in expansion pins (18) and bolt down cheese-head screws (19).

(Fig. 43, 44, 65)

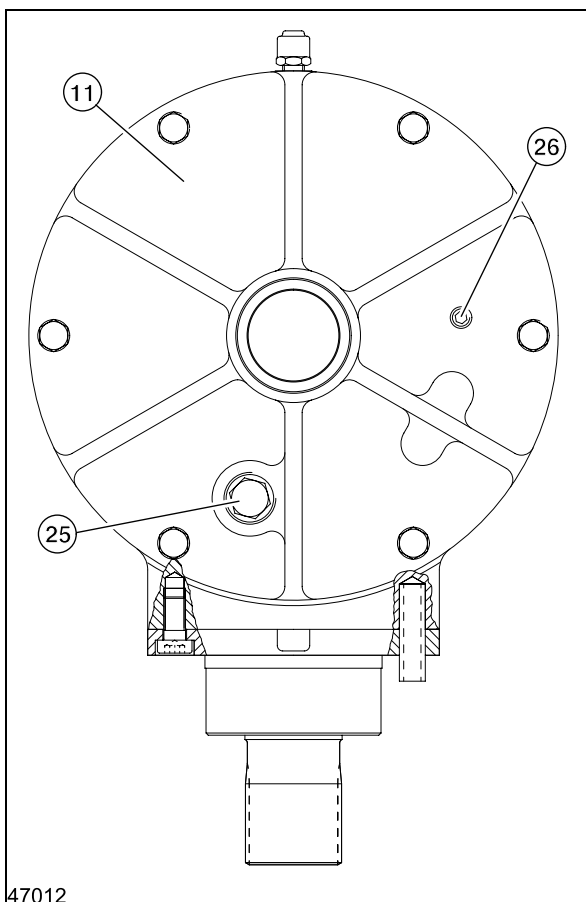

66

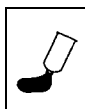

(on spare part no. 643 656.1)

Bolt on transmission cover (11) with liquid sealing compound.

(on spare part no. 643 656.2)

Insert O-ring (20) and bolt down transmission cover (11).



Important!

When bolting on the transmission cover (11) observe the position of the screw plug (26) relative to the transmission housing (3).

Bolt down hexagon bolt (13).

Tightening torque **M 8 - 10.9 = 33 Nm**

(Fig. 43, 44, 66)

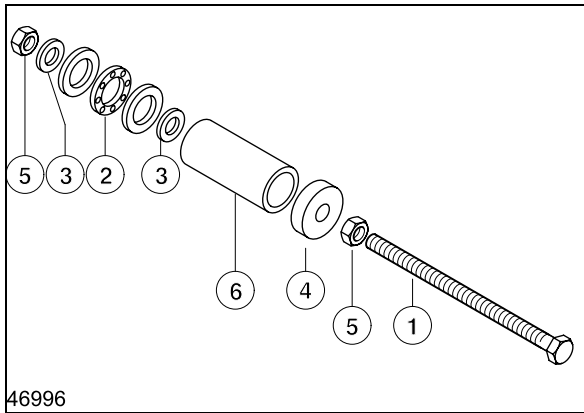

91

Special tool:

- 1 Hexagon bolt M 12 x 220 DIN 933
Spare part no. 244 422.0
- 2 Axial grooved ball bearing
Spare part no. 177 899.0
- 3 Washer 13 x 30 x 3
Spare part no. 238 206.0
- 4 Washer 13 x 45 10,
Spare part no. 712 415.0
- 5 Hexagon nut M 12 DIN 934
Spare part no. 263 172.0
- 6 Tube (self-manufactured)
Ø 40 x Ø 34 x 70 mm

(Fig. 90, 91)

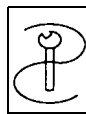
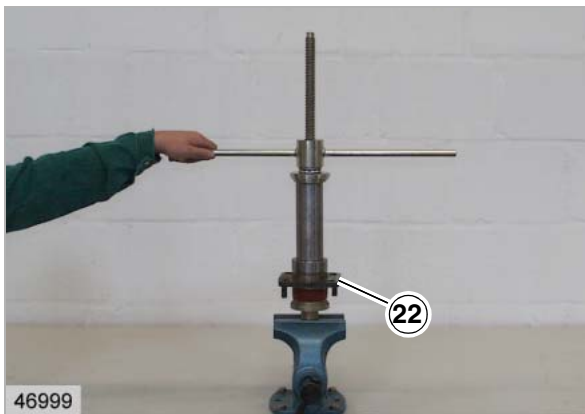

Force needle bushing (27) into the bearing housing (22) with special tool.



Important!

The inside bearing must be flush with the housing edge. The outer bearing must have a clearance of X = 12 mm from the housing edge.

(Fig. 88, 89, 92, 93)

92

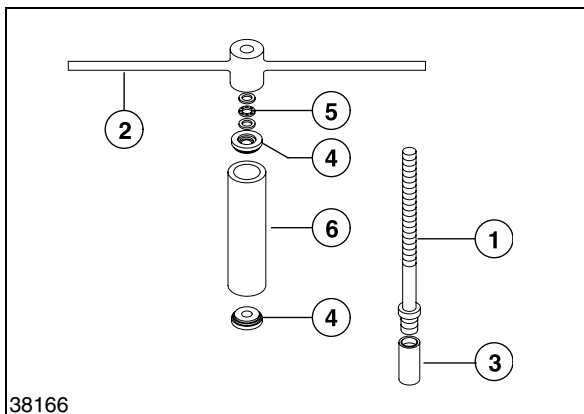

93

Special tool:

- 1 Spindle
Spare part no. 244 422.0
- 2 Lever nut
Spare part no. 181 880.0
- 3 Sleeve
Spare part no. 181 881.0
- 4 Locating disc
Spare part no. 181 879.0
- 5 Axial grooved ball bearing
Spare part no. 177 899.0
- 6 Tube (self-manufactured)
Ø 62 x Ø 52 x 150 mm

(Fig. 92, 93)

5

Intake auger

INTAKE AUGER

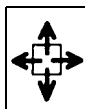
**Removing the left-hand intake auger bearing**

Removing the knife drive belt (40), see page 4.3.1
(on 7.5 m cutterbars) There is no need to remove the knife drive pulley of the wobble transmission.

Removing the feed drive chain (41), see page 5.1.1

Removing the intake auger slip clutch, see page 5.1.3

Loosen and remove set collar (30). Loosen lock collar (28).

(Fig. 1, 6)

1

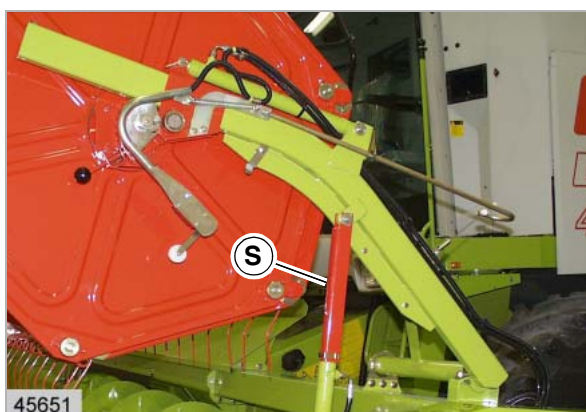

Raise reel completely.
Apply reel support (S) on both sides.

**Danger!**

Stop the engine and remove ignition key.

(Fig. 2)

2

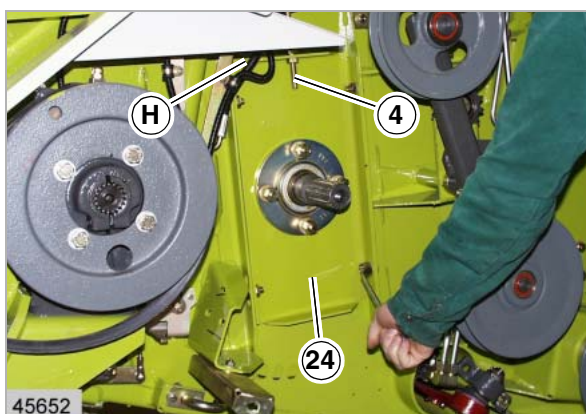
**Danger!**

Danger of injury on the reel tines.

☞ When working beneath the reel, wear a hard hat and set the reel tines to the rear.

3

**Danger!**

Put safety bar on the double fingers and/or on the crop lifters.

Safely support intake auger so it cannot fall down.

Unscrew the left-hand bearing plate (24) and unscrew hexagon bolt (4).

(Fig. 3)

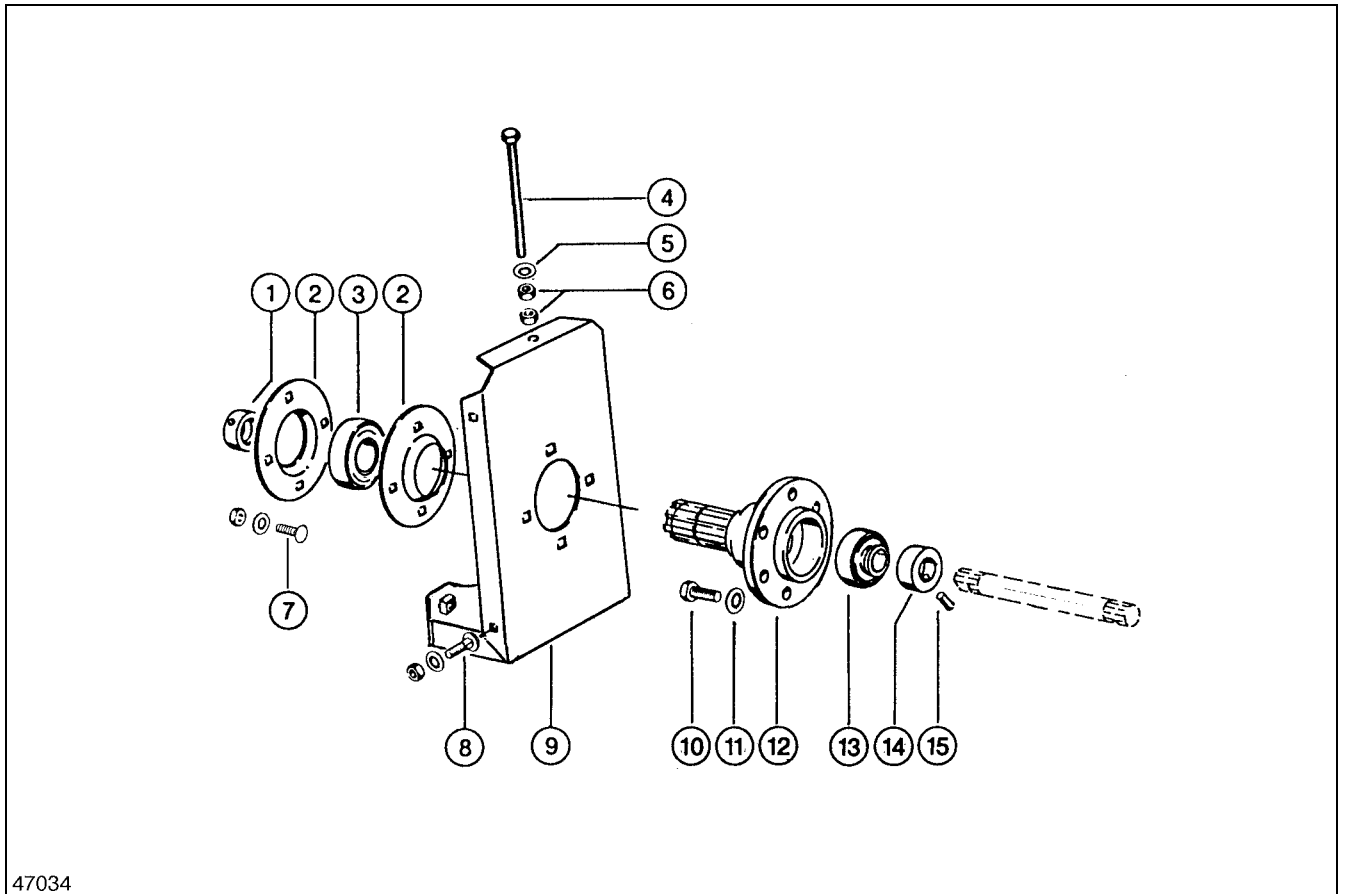

47034

23

Right-hand intake auger bearing, disassembled

- 1 Lock collar 50
Set screw M 10 x 1.25 x 8
- 2 Sheet-metal flange Rb y 210
- 3 Lock collar bearing Yen 210-s
- 7 Cheese-head screw M 12 x 30 DIN 4762
Contact washer A 12
Hexagon nut M 12 DIN 934
- 9 Bearing plate right-hand
- 10 Hexagon bolt M 12 x 25 DIN 933
- 11 Contact washer A 12
- 12 Flange
- 13 Lock collar bearing Rae 30nppbfa 140
- 14 Lock collar 30 fa 125/171
- 15 Set screw M 8 x 10 DIN 916

(Fig. 23)

CLICK HERE TO **DOWNLOAD** THE COMPLETE MANUAL

- Thank you very much for reading the preview of the manual.
- You can download the complete manual from: www.heydownloads.com by clicking the link below



- Please note: If there is no response to CLICKING the link, please download this PDF first and then click on it.

CLICK HERE TO **DOWNLOAD** THE COMPLETE MANUAL

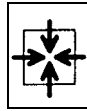
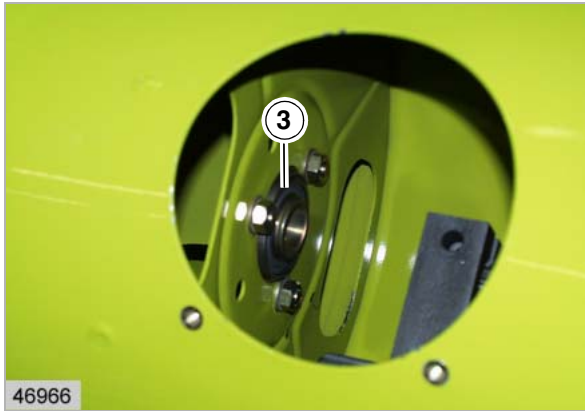

Installing the control shaft

Loosely bolt on the flange bearing (3).



Important!

Observe installation position!

(Fig. 45, 50)

50

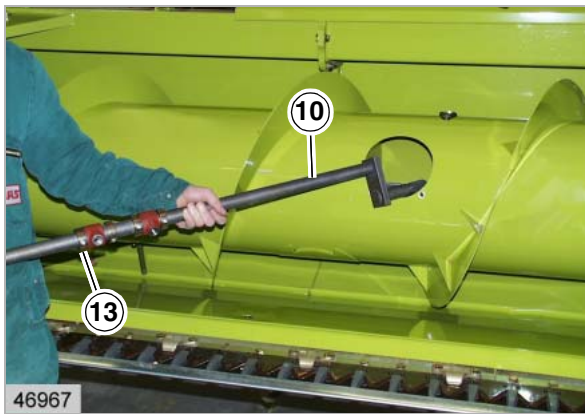

Clean control shaft (10).

Slide swivel bearing (19) and set collars (13) on the control shaft (10).



Important!

Slightly bolt on the last set collar (13) and thus secure against slipping off.

Introduce control shaft (10) through the installation opening into the flange ball bearing.

10 Control shaft (to be removed)

(Fig. 50, 51)

51

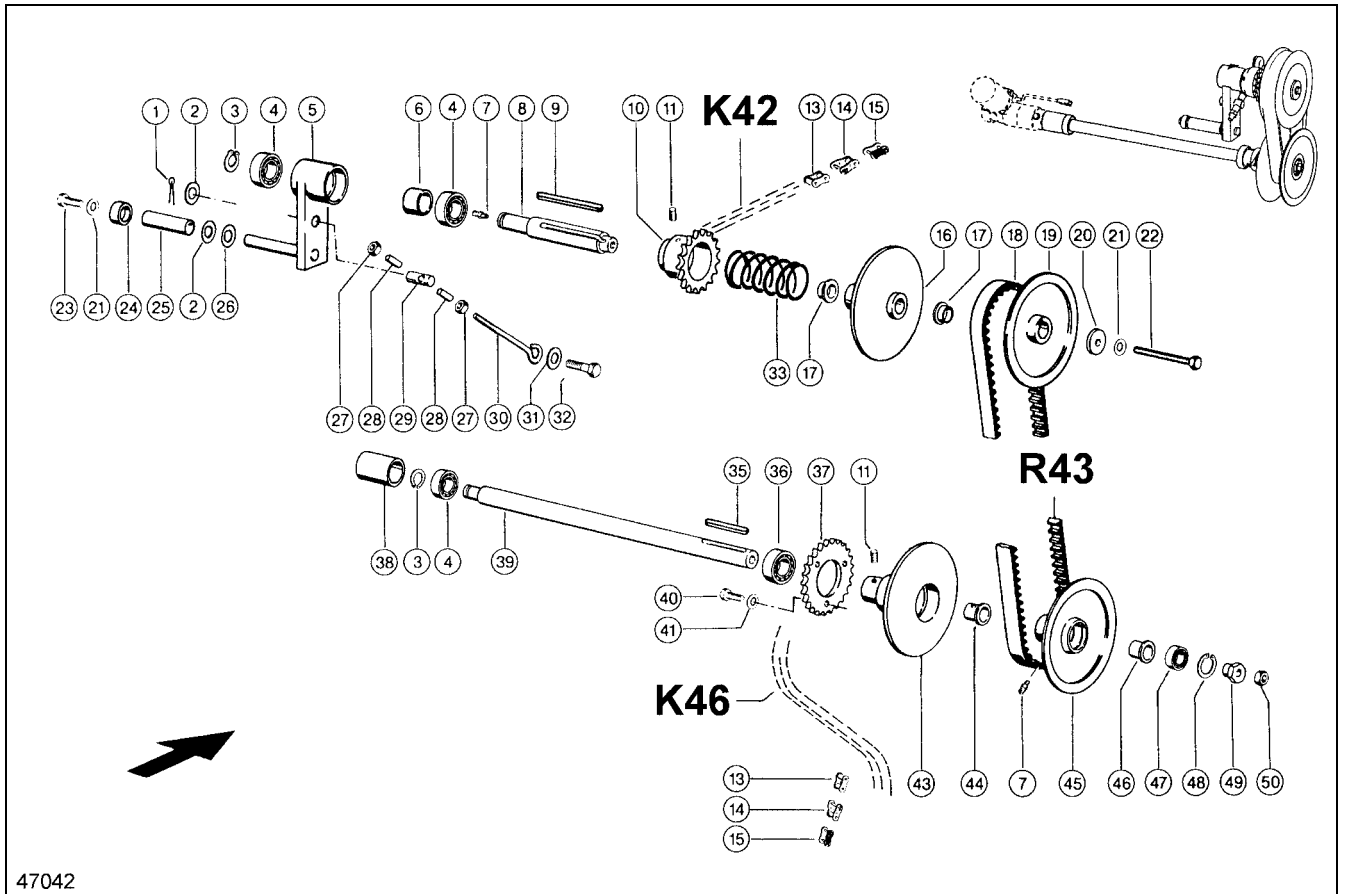

1

REEL DRIVE BELT / DRIVE CHAINS

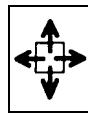

Removing the reel drive chain (42)

Unscrew the inside guard (S).

(Fig. 2)

2

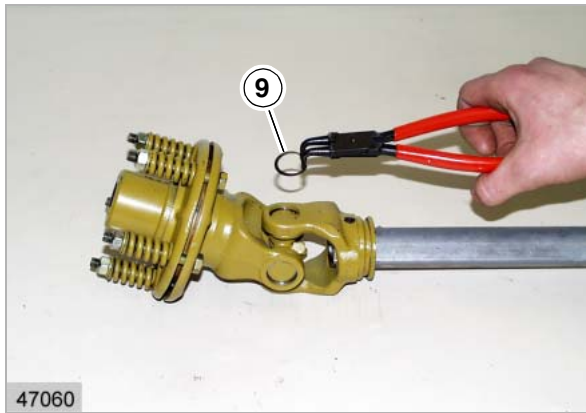

8

Remove all four circlips (9) from the two yokes.
(Fig. 8, 14)

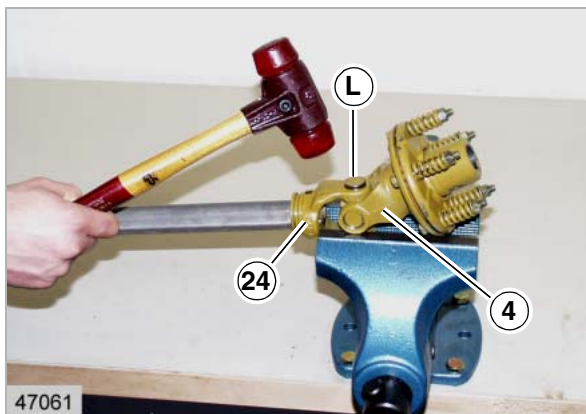

9

Place the yoke of the friction clutch (4) in position and drive the bearing sleeves (L) upwards with slight blows on the grooved yoke (24).
(Fig. 9, 14)

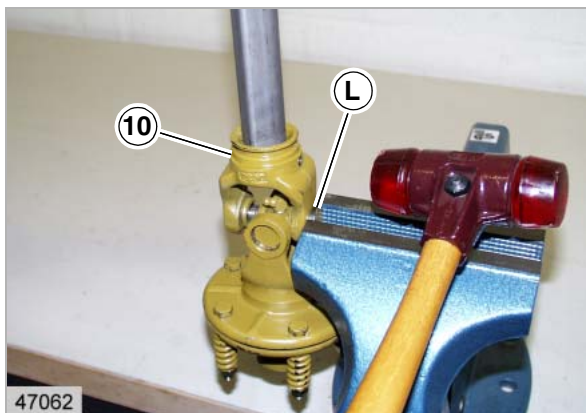

10

Chuck bearing sleeve (L) and remove bearing sleeve by slight blows on the yoke (24) and/or by rotating movements.
(Fig. 10, 14)

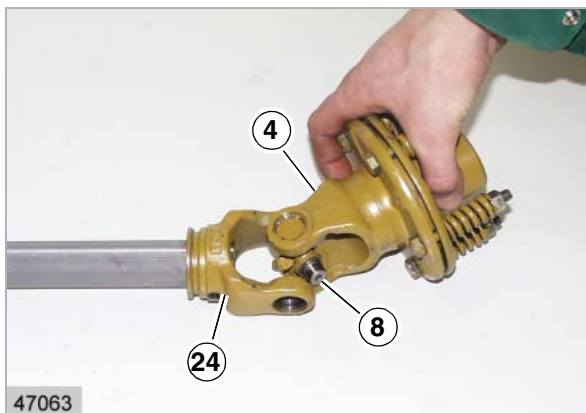

11

Remove friction clutch (4) with centre cross assembly (8) from the grooved yoke (24).
(Fig. 11, 14)

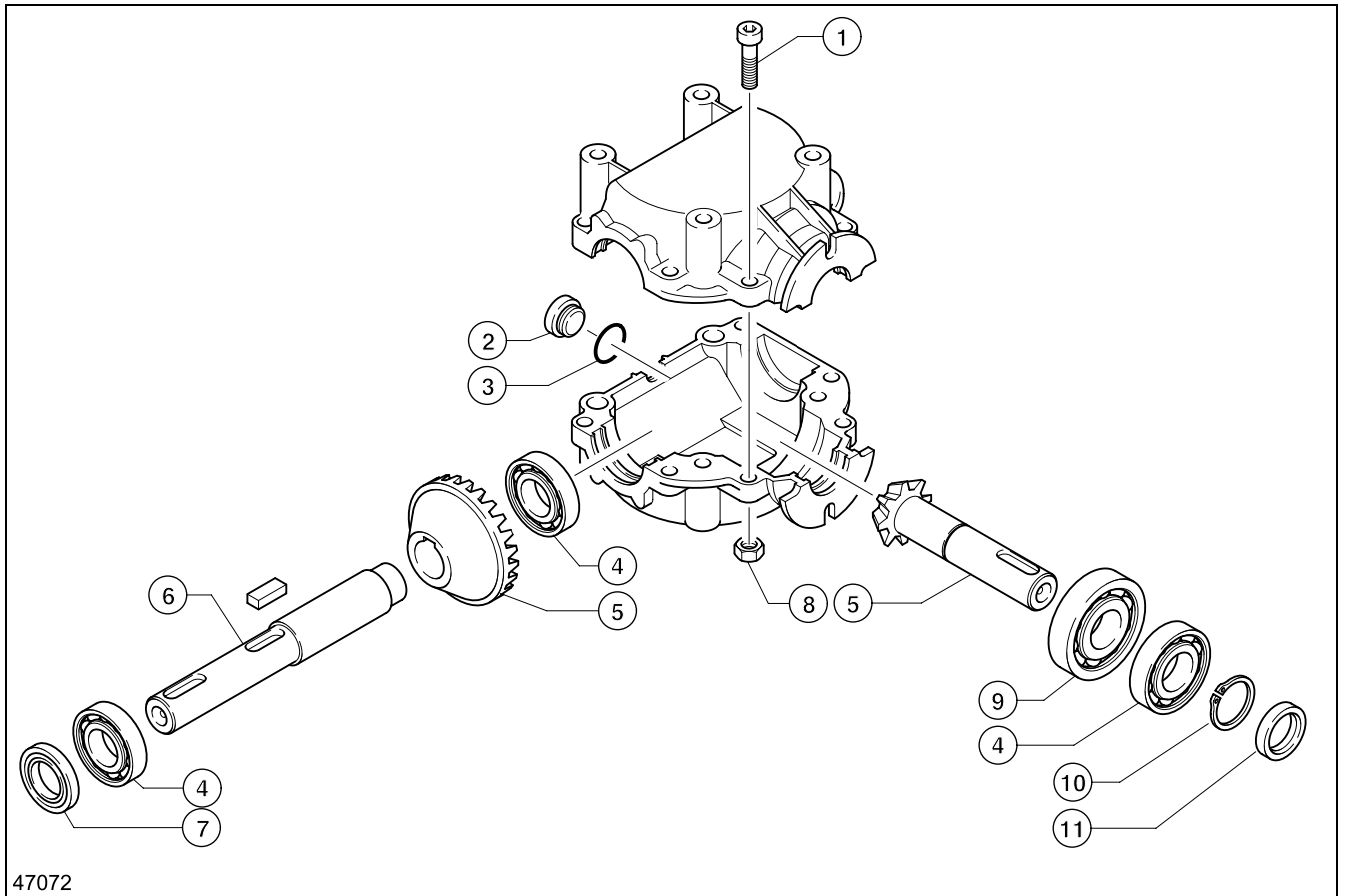

Rear angle drive, disassembled:

- 1 Cheese-head screw M 8 x 40 DIN 4762
- 2 Screw plug
- 3 O-ring 17 x 2 -n DIN 3771
- 4 Deep groove ball bearing 6205 DIN 625
- 5 Sprocket set
Bevel gear shaft
Crown wheel
- 6 Shaft end
- 7 Shaft seal A 25 x 47 x 7 DIN 3760
- 8 Self-locking nut Vm 8
- 9 Deep groove ball bearing 6305 DIN 625
- 10 Circlip 25 x 2 DIN 471
- 11 Shaft seal A 25 x 35 x 7 DIN 3760

(Fig. 37)



47093

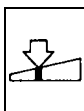

Install front circlip (6) at the front deep groove ball bearing (7).

Checking and adjusting the backlash:

The backlash can be adapted by adding or removing shims (17).

Backlash: **0.2 – 0.3 mm.**

(Fig. 56, 57, 63)

63



47094

Drive in cover (5) and shaft seals (10,16) with a block-ended tube.



Important!

Slightly oil dust lips of shaft seals. Apply e.g. Omni-FIT-FD-10 to metal shaft seals.

(Fig. 56, 57, 64)

64

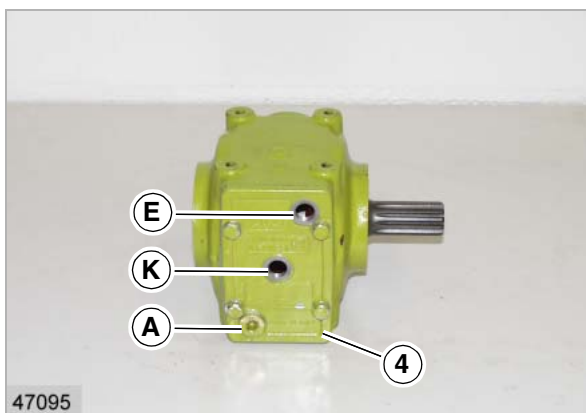

47095

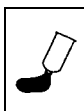

Bolt on transmission cover (4).



Important!

Apply e.g. Omni-FIT-FD-10 to the sealing faces of the transmission cover.

Screw in oil drain plug (A). Place transmission in a horizontal position. Top up transmission oil and plug the screw plugs (K, E).

- 18 Screw plug
- A – Oil drain plug
- K – Oil level check plug
- E – Oil drain plug

For oil quantity: see *Lubricants chart*, page 1.5.1

(Fig. 56, 57, 65)

65

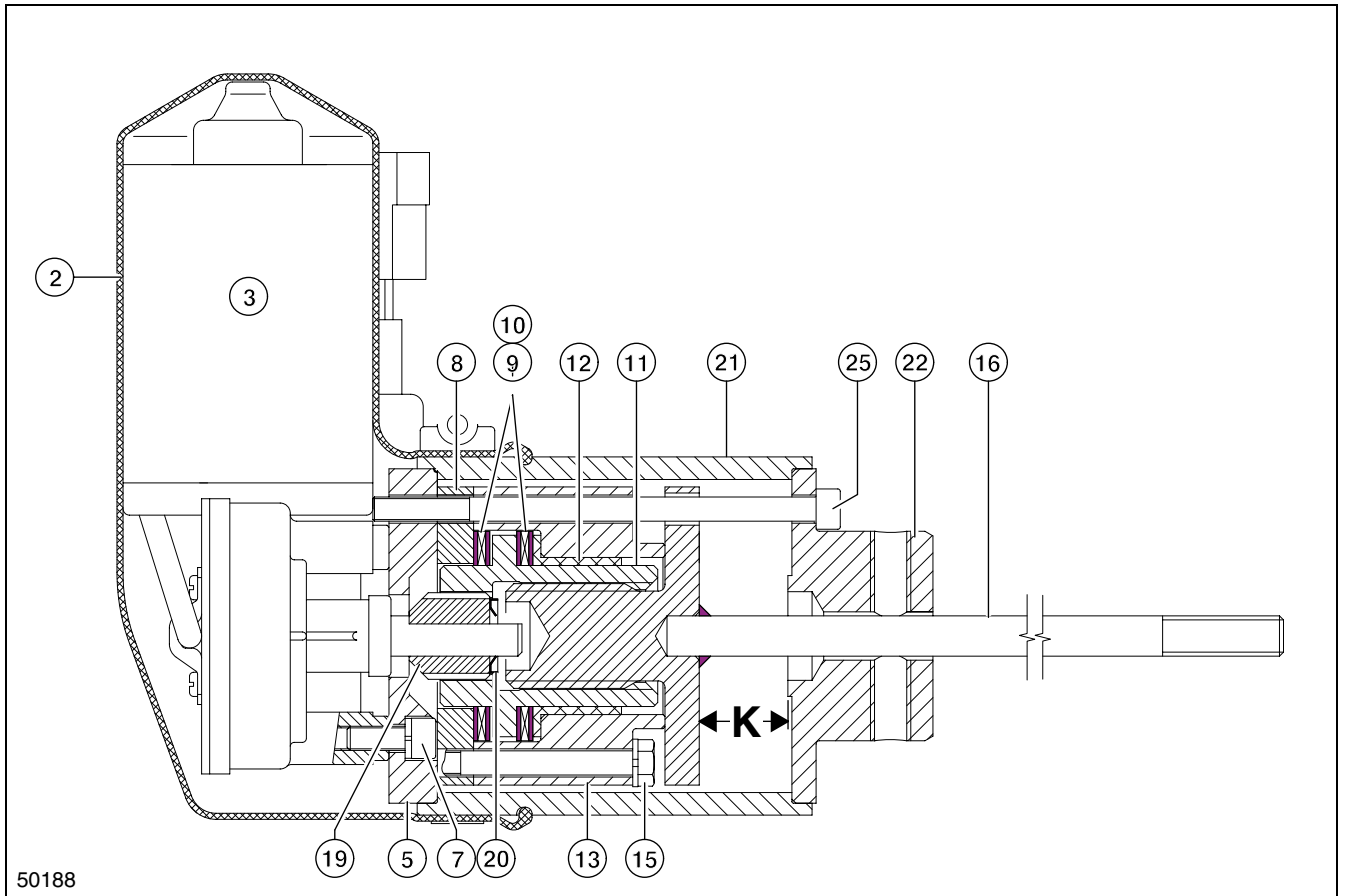

50188

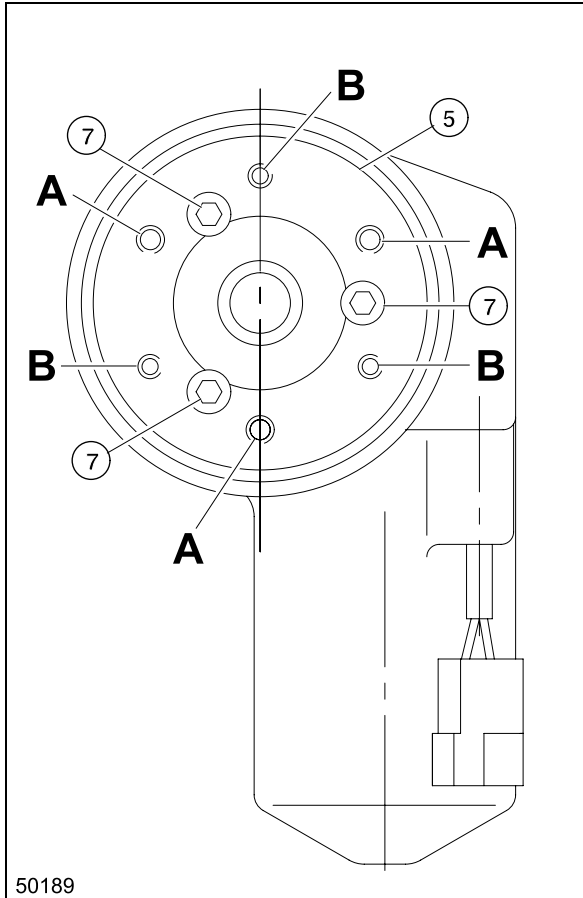

50189

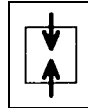

Assembling the electric reel speed adjustment
(up to machine no.)

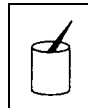

Important!
Prior to assembly, apply K2K grease according to DIN 51825, lithium-stiffened multi-purpose grease, e.g. Shell "Alvania G2" or similar brands to all sliding faces, axial washers and needle bearings.

Bolt flange (5) on the DC motor (3) with the cheese-head screws (7).

Tightening torque **M 6 x 16 = 8 Nm**

(Fig. 20, 21)

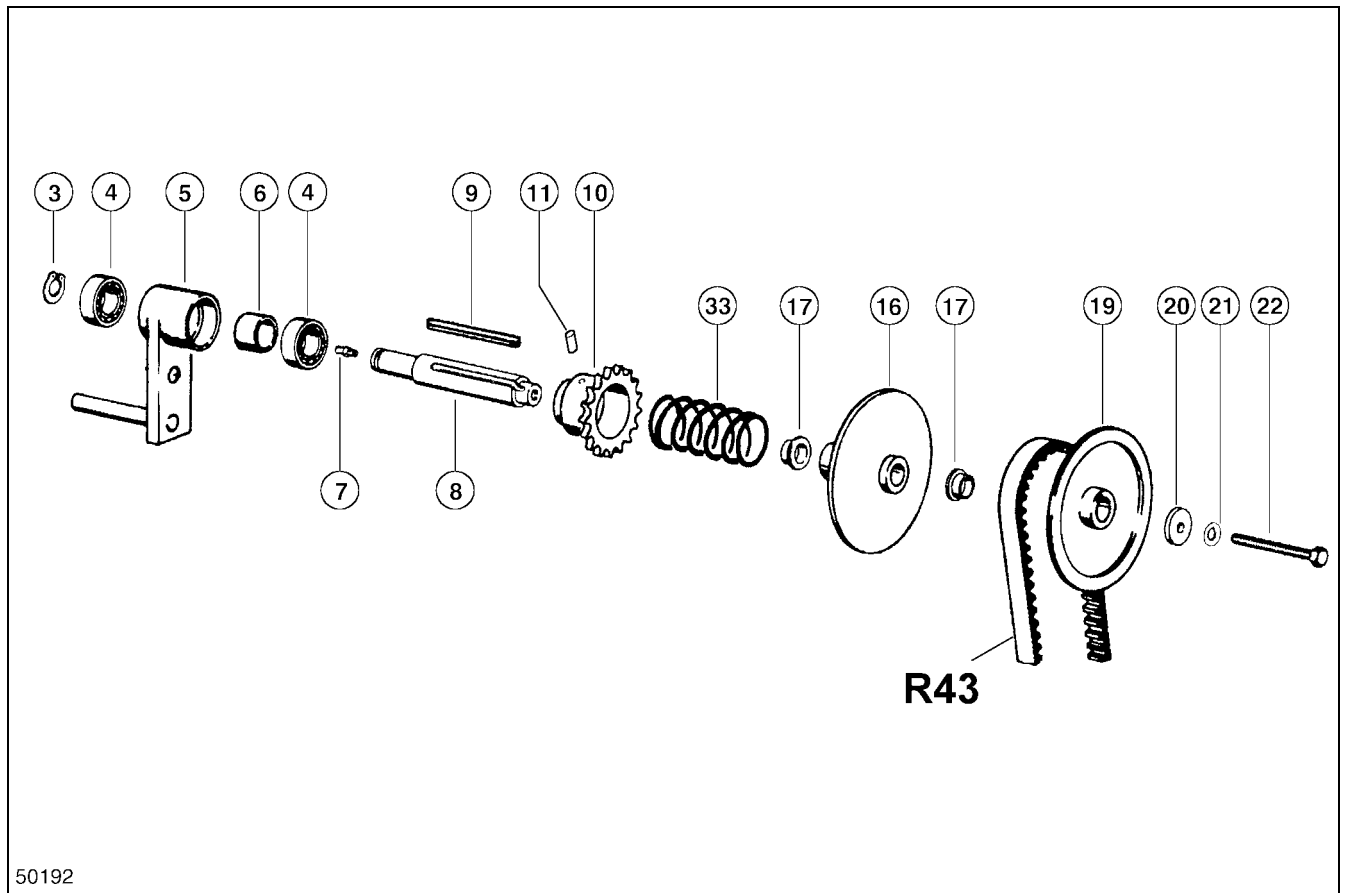

50192

46

Spring-loaded reel variable-speed pulley, disassembled

- 3 Circlip 25 x 1,2 DIN 471
 - 4 Deep groove ball bearing 6205-2rs*
 - 5 Tensioning arm
 - 6 Spacer tube
 - 7 Grease nipple As 6 x 1 DIN 71412
 - 8 Drive shaft D 30, 224 lang
 - 9 Parallel key 9 x 10 x 135
 - 10 Sprocket
 - 11 Set screw M 10 x 12 DIN 916
 - 16 Variable speed pulley
 - 17 Bushing
 - 19 Variable speed pulley
 - 20 Locating disc
 - 21 Contact washer A 10
 - 22 Hexagon bolt M 10 x 140
 - 33 Compression spring
- R43** = Reel drive belt (43)

(Fig. 46)

Reel, disassembled

- | | |
|--|-------------------------------------|
| 1 Spring tine reel | 63 Slide plate |
| 2 Hexagon bolt M 8 x 12 DIN 933 | 64 Grease nipple As 6 x 1 DIN 71412 |
| 3 Contact washer A 8 | 65 Shim |
| 4 Tine | 66 Set collar |
| 5 Plug | 67 Hexagon nut M 10 DIN 936 |
| 6 Mounting plate | 68 Set screw M 10 x 16 DIN 916 |
| 7 Bushing | 69 Right-hand reel support arm |
| 8 Shim | 70 Mounting plate |
| 9 Expansion pin 8 x 40 DIN 8752 | 71 Reel bearing |
| 10 Tine tube | 72 Mushroom head bolt M 10 x 25 |
| 11 Mushroom head bolt M 8 x 50 DIN 603 | 73 Washer |
| Hexagon nut M 8 DIN 934 | 74 Left-hand reel support arm |
| Contact washer A 8 | 75 Hexagon bolt M 10 x 25 |
| 12 Tine spring | Self-locking nut Vm 10 10.9 |
| 13 Self-locking nut Vm 8 | Contact washer A 10 |
| 14 Washer | 76 Spring bracket |
| 15 Hexagon bolt M 8 x 16 DIN 933 | 77 Reel support |
| 16 End piece | 78 Spacer tube |
| 17 Hexagon bolt M 8 x 40 DIN 931 | 79 Leaf spring |
| Hexagon bolt M 8 x 50 DIN 931 | 80 Hexagon bolt M 8 x 55 DIN 931 |
| Hexagon nut M 8 DIN 934 | Hexagon nut M 8 |
| Contact washer A 8 | Contact washer A 8 |
| 18 Parallel key A 10 x 8 x 110 | 81 Expansion pin 8 x 45 DIN 8752 |
| 19 Reel spider | 82 Reel bearing |
| 20 Hexagon bolt M 10 x 20 | 83 Washer |
| Contact washer A 10 | 84 Set collar |
| 21 Reel shaft | 85 Hexagon bolt M 10 x 25 |
| 22 Hexagon bolt M 10 x 25 rs | 86 Hexagon nut M 10 DIN 936 |
| 23 Hexagon nut M 10 | 87 Bushing |
| 24 Reel spider | |
| 25 Hexagon bolt M 8 x 20 | |
| Hexagon nut M 8 DIN 934 | |
| Contact washer A 8 | |
| 26 Reel centre tube | |
| 27 Reel spider | |
| 28 Control spider | |
| 29 Pin | |
| 30 Control roller | |
| 31 Bushing | |
| 32 Control roller holder | |
| 33 Grease nipple As 6 x 1 DIN 71412 | |
| 34 Ball head | |
| 35 Pin | |
| 36 Compression spring | |
| 37 Washer | |
| 38 Expansion pin 3 x 22 DIN 8752 | |
| 39 Spring washer | |
| 40 Hexagon nut M 12 | |
| 41 Drive shaft | |
| 42 Set collar | |
| 43 Hexagon nut M 10 | |
| 44 Set screw M 10 x 16 | |
| 45 Round plate | |
| 46 Set collar | |
| 47 Set screw M 10 x 8 DIN 913 | |
| 61 Bushing | |
| 62 Reel bearing | |

(Fig. 8)

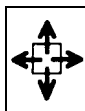
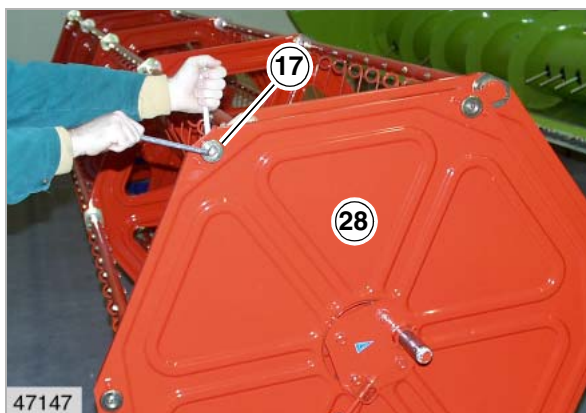

Removing the centre reel spider



Important!

The mounting of the centre reel spiders is shown here. Depending on the damage, it may be sufficient to start the repair from one machine side.

35

Removing the reel, see page 6.4.1

Removing the reel bearing, see page 6.4.8

Left-hand machine side:

Unscrew hexagon bolts (17) and remove end pieces (16).

Pull off control spider (28) completely with control rollers (30) and control roller holder (32).

(Fig. 8, 35)

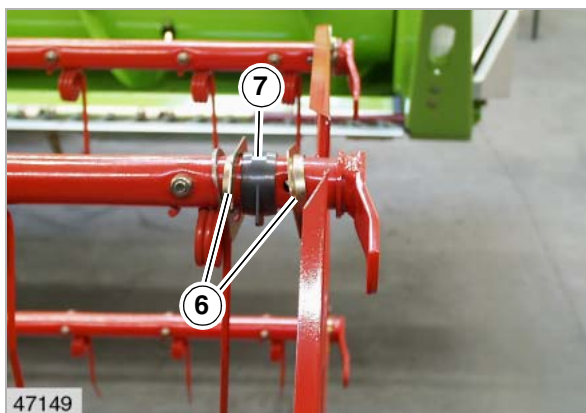

36

Unscrew reel spider (27).

To do this, drive all expansion pins (9) out of the tine tubes (10). Push the mounting plates (6) and bushings (7) to the inside.

(Fig. 8, 36)

Right-hand machine side:

Removing the outside right-hand reel spider, see page 6.4.12



37

Place supports under the reel centre tube.

Unscrew the tine tubes (10). To do this, loosen the mounting plates (6) on the reel spiders and pull off the tine tubes (10) to the outside.

(Fig. 8, 37)

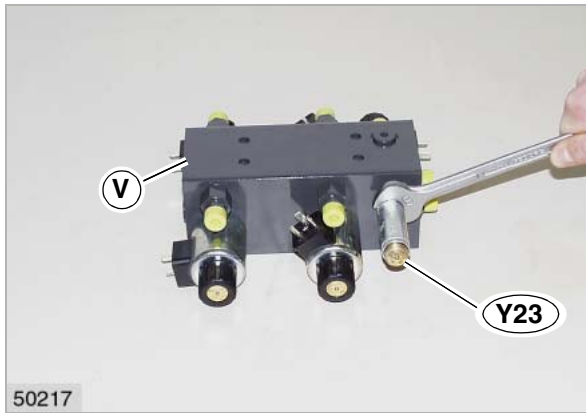

12

Unscrew iron core of solenoid (Y23) from the valve block (V).



Environment!

Dispose of leaking hydraulic oil properly!

(Fig. 4, 12, 14)



13

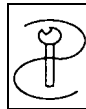

Pull out valve cartridge (19) with special tool.

Special tool:

Magnetic rod, part no. 181 842.0

(Fig. 4, 13, 14)

Reel lower 2/2-way valve (Y23), disassembled

– see page 7.1.2

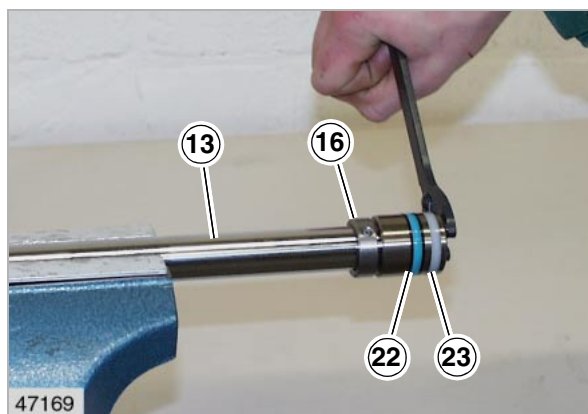

Slide on set collar (16) and arrest with expansion pins (14, 15) on the connecting rod (13).

Pre-assemble ram (21) with the parts (17, 18, 19). Mount ram seal (22) and guide ring (23) on the ram (21).



Important!

To make assembly easier parts (22 and 23) can be warmed up in warm water (**max. 60 °C**).

11

Mount O-ring (20) on the connecting rod (13).

Screw the pre-assembled ram (21) to the connecting rod (13).

Tightening torque = **50 Nm**

(Fig. 8, 9, 11)

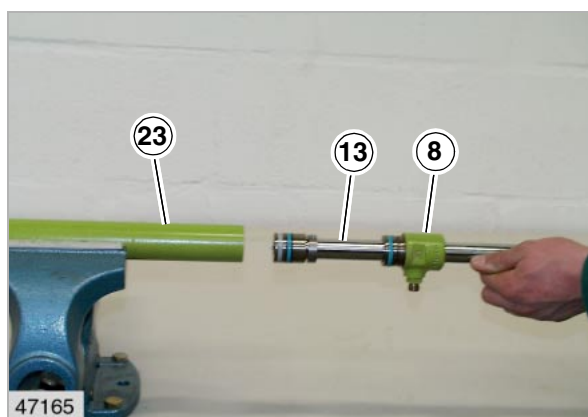

Slide the pre-assembled cylinder head (8) on the connecting rod (13).

Slide the pre-assembled connecting rod (13) into the cylinder barrel (24).

(Fig. 8, 9, 12)

12

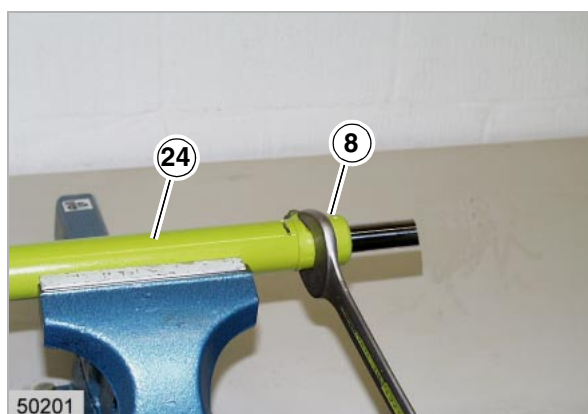

Turn cylinder head (8) into the cylinder barrel (24) with new securing wire (10).

(Fig. 8, 9, 13)

13

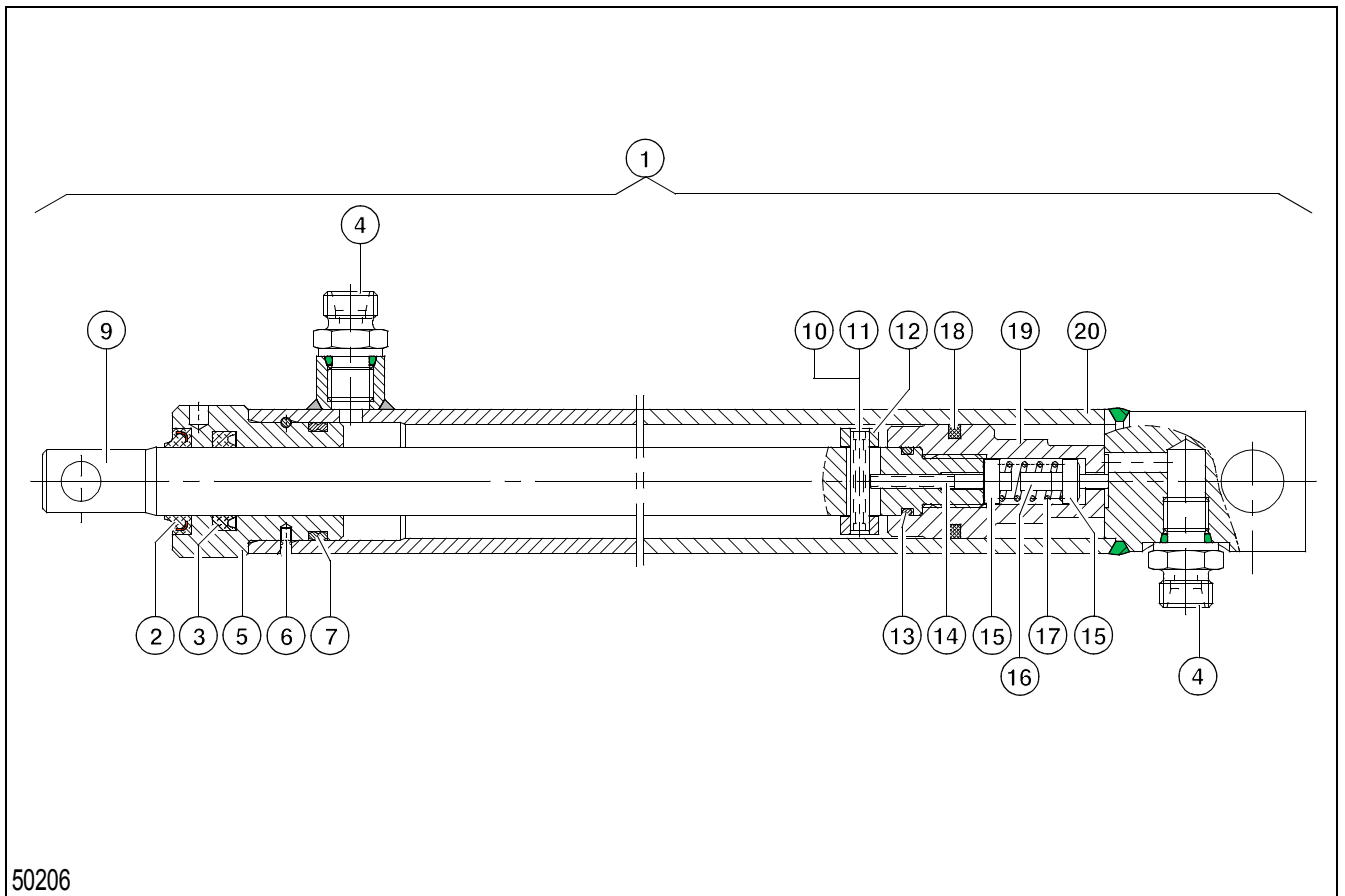

50206

38

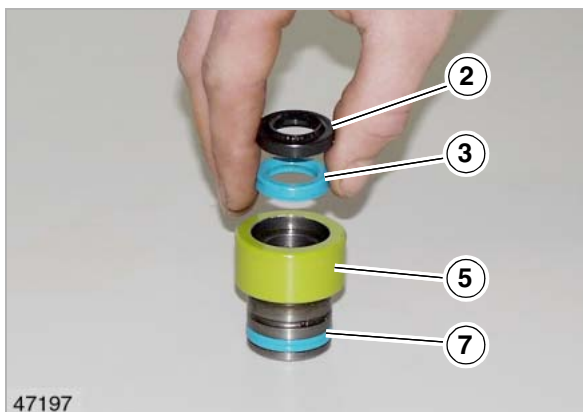

47197

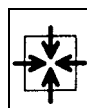

Assembling the reel horizontal adjustment hydraulic cylinder



Important!

Prior to mounting, apply hydraulic oil to all moving parts, especially the seals.

39

Install scraper ring (2) and seal (3) in the cylinder head (5) in the order shown.

Pre-assemble dual seal ring (7) on the cylinder head (5).

(Fig. 37, 38, 39)

HYDRAULIC MOTORS / PUMPS

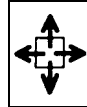
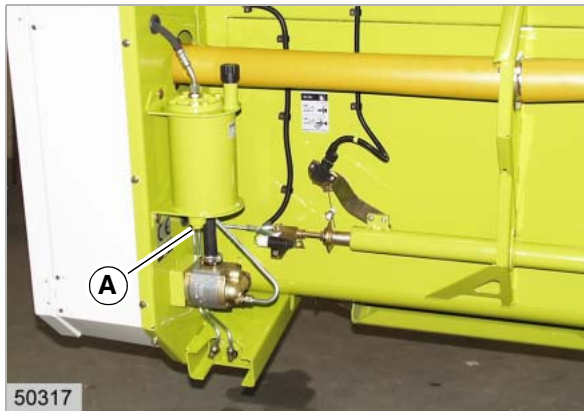

Removing the rape side cutter hydraulic pump

Drain hydraulic oil at the oil drain plug (A).



Environment!

Dispose of drained hydraulic oil properly!

(Fig. 1)

1

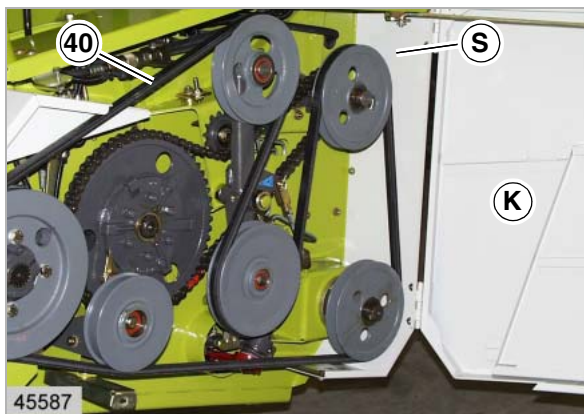

Unscrew guard (S) with door (K).

Removing the knife drive belt (40), see page 4.3.1.

(Fig. 2)

2

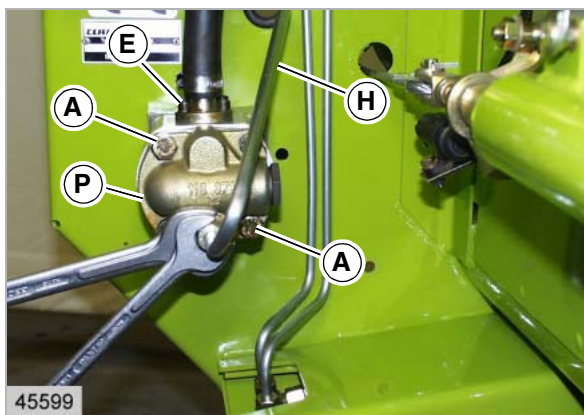

Unscrew hydraulic line (H) from pump (P) and close line.

Unscrew cheese-head screws (E). Loosen hose clamp if required.

Unscrew pump (P) at the two hexagon bolts (R) and remove pump (P).



Important!

When removing the pump, the catch (X) may fall out.

3

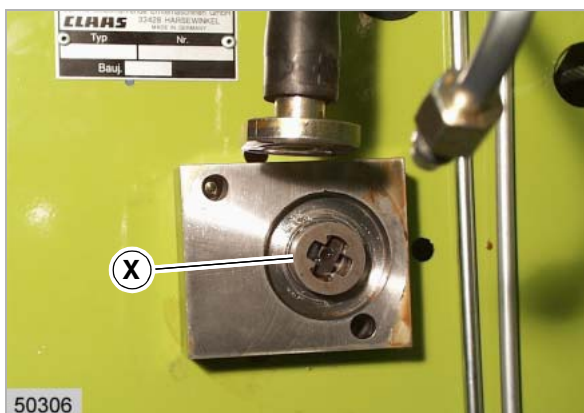

(Fig. 3, 4)

4

CLICK HERE TO **DOWNLOAD** THE COMPLETE MANUAL

- Thank you very much for reading the preview of the manual.
- You can download the complete manual from: www.heydownloads.com by clicking the link below



- Please note: If there is no response to CLICKING the link, please download this PDF first and then click on it.

CLICK HERE TO **DOWNLOAD** THE COMPLETE MANUAL